

## GROUP 2 ENGINE SYSTEM

### ENGINE AND ACCESSORIES MOUNTING

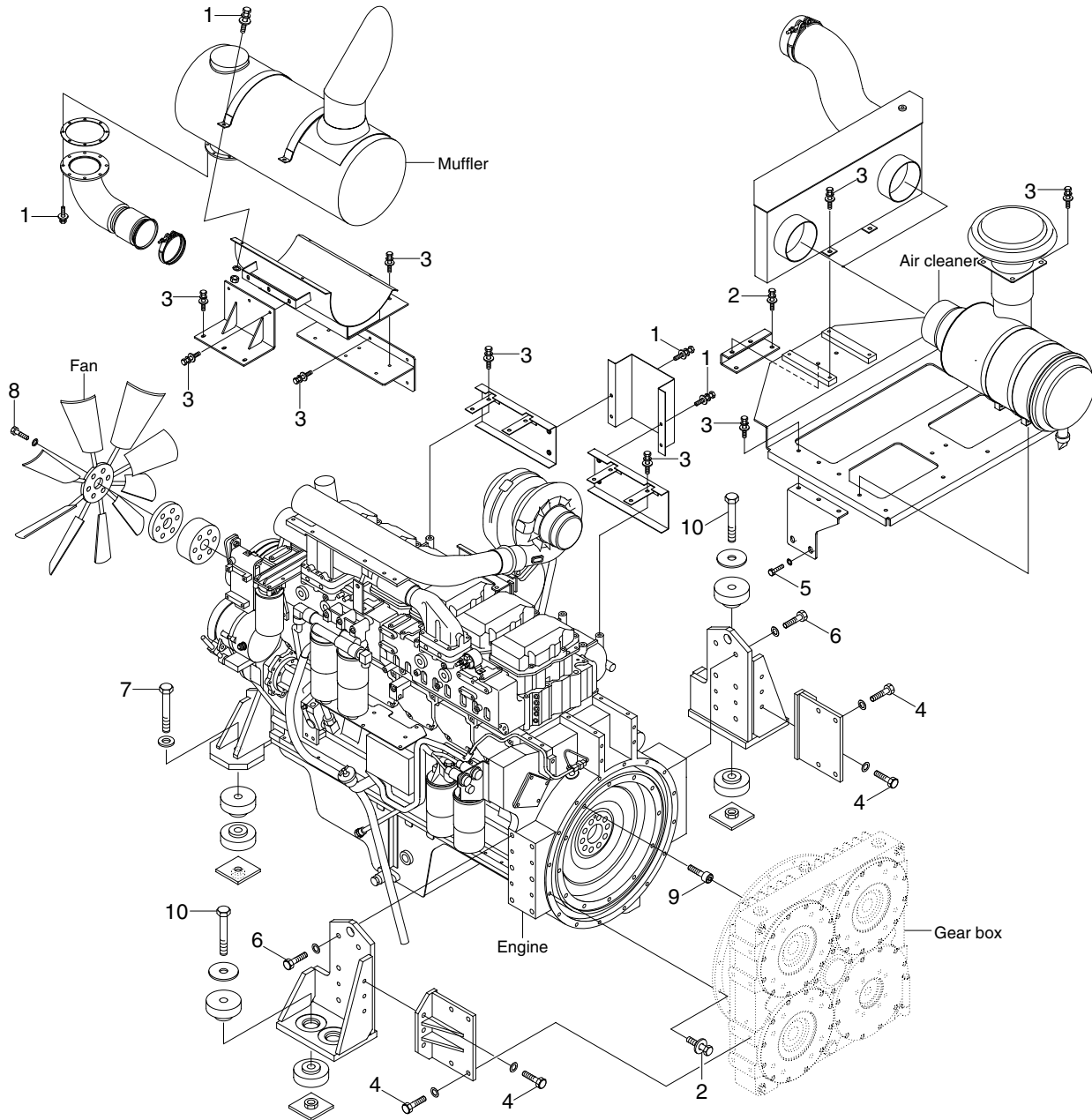

120099CM01

#### · Tightening torque

Item	Size	kgf · m	lbf · ft
1	M10×1.5	6.9±1.4	49.9±10.1
2	M12×1.75	12.3±1.0	89±7.2
3	M12×1.75	12.3±2.4	88.9±17.3
4	M16×2.0	29.7±3.0	215±21.7
5	M16×2.0	29.7±5.0	215±36.1

Item	Size	kgf · m	lbf · ft
6	M18×2.5	41.3±4.0	299±29
7	M22×2.5	70±7.0	506±50.6
8	1/2-13UNC	13.4±1.0	97±7.2
9	5/8-11UNC	27±3.0	195±21.7
10	M24×3.0	100±10	723±7.2

# OIL COOLER AND FAN DRIVE MOUNTING

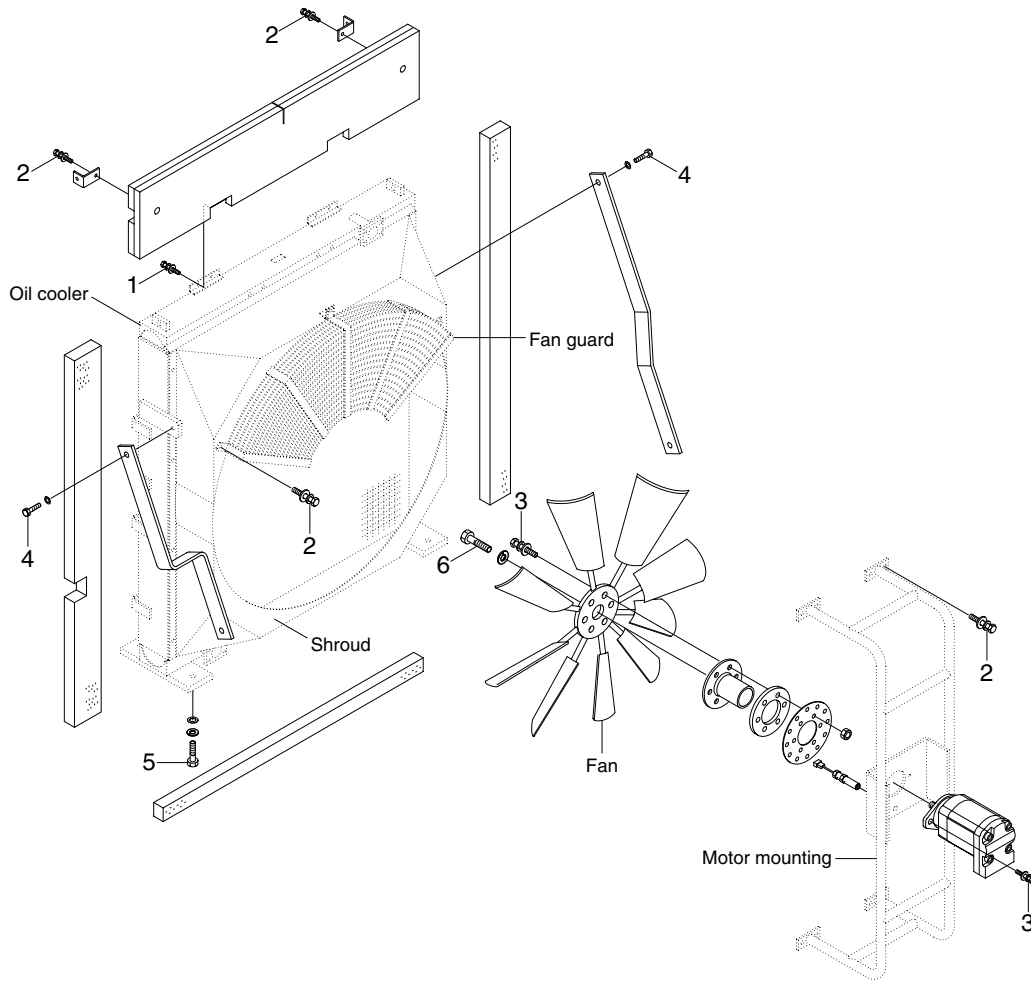

120099CM02

## · Tightening torque

Item	Size	kgf · m	lbf · ft
1	M8×1.25	2.5±0.5	18.1±3.6
2	M10×1.5	6.9±1.4	49.9±10.1
3	M12×1.75	12.8±3.0	92.6±21.7

Item	Size	kgf · m	lbf · ft
4	M14×2.0	14.4±2.2	104±16
5	M20×2.5	57.9±8.7	419±62.9
6	5/16-18UNC	3.4±0.4	24.6±2.9

# COOLING SYSTEM AND FUEL TANK MOUNTING

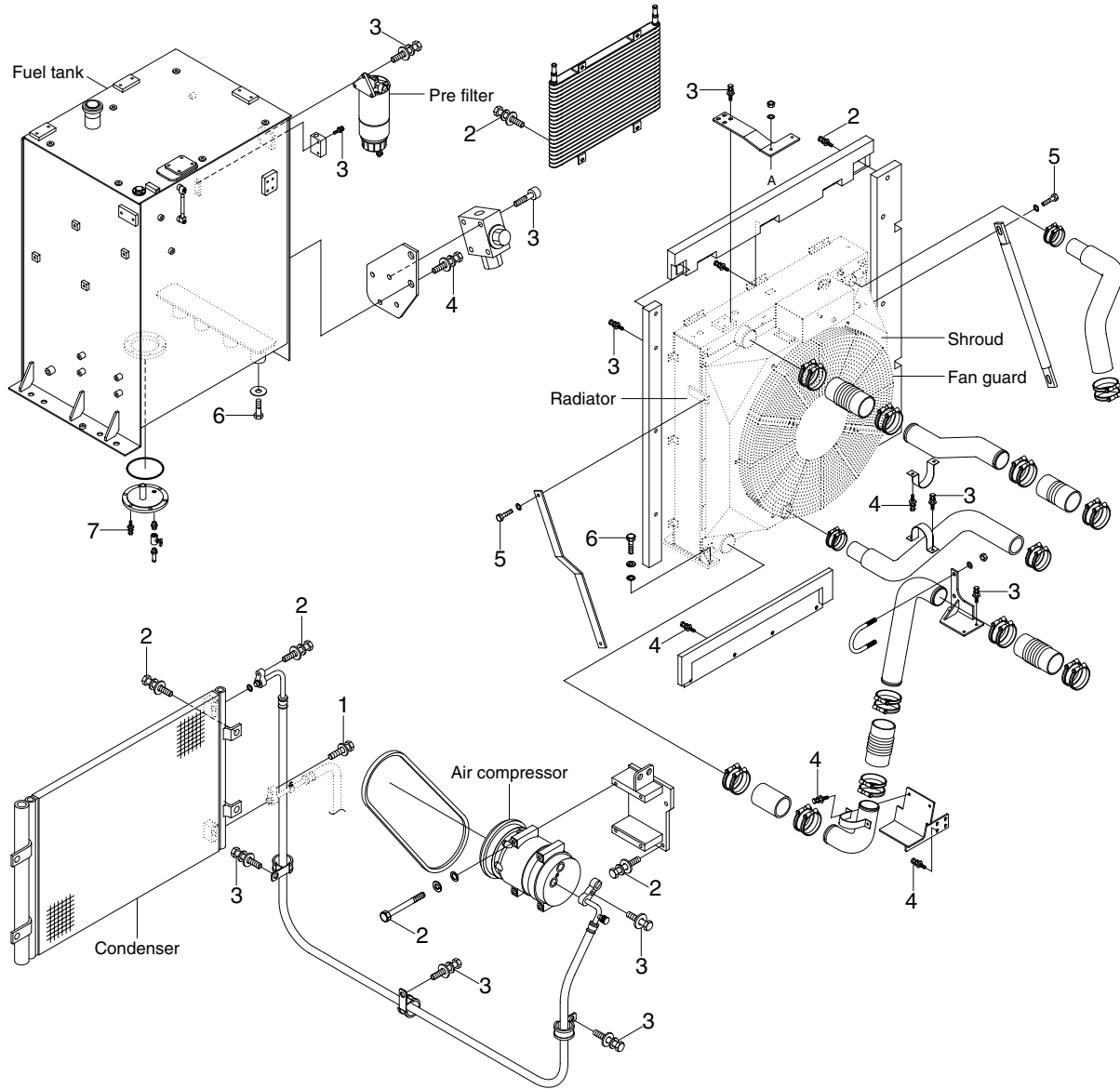

120099CM03

## · Tightening torque

Item	Size	kgf · m	lbf · ft
1	M6×1.0	1.05±0.2	7.6±1.45
2	M8×1.25	2.5±0.5	18.1±3.6
3	M10×1.5	6.9±1.4	49.9±10.1
4	M12×1.75	12.8±3.0	92.6±21.7

Item	Size	kgf · m	lbf · ft
5	M14×2.0	14.4±2.2	104±16
6	M20×2.5	45±5.1	325±37
7	-	2.3±0.6	16.6±4.3