

SECTION 5 MECHATRONICS SYSTEM

Group 1 Outline	5-1
Group 2 Mode Selection System	5-3
Group 3 Power Boost System	5-4
Group 4 Travel Speed Control System	5-5
Group 5 Automatic Warming Up Function	5-6
Group 6 Engine Overheat Prevention Function	5-7
Group 7 Anti-Restart System	5-8
Group 8 Self-Diagnostic System	5-9
Group 9 Engine Control System	5-11
Group 10 EPPR(Electro Proportional Pressure Reducing) Valve	5-17
Group 11 Prolix Switch	5-20
Group 12 Monitoring System	5-21

SECTION 5 MECHATRONICS SYSTEM

GROUP 1 OUTLINE

The NEW CAPO(Computer Aided Power Optimization) system controls engine and pump mutual power at an optimum and less fuel consuming state for the selected work by mode selection, one touch deceleration, power boost function, etc. It monitors machine conditions, for instance, engine speed, coolant temperature, hydraulic oil temperature, and hydraulic oil pressure, etc.

It consists of a CPU controller, a cluster, an accel actuator, an EPPR valve, and other components. The CPU controller, and the cluster protect themselves from over-current and high voltage input, and diagnose malfunctions caused by short or open circuit in electric system, and display error codes on the cluster.

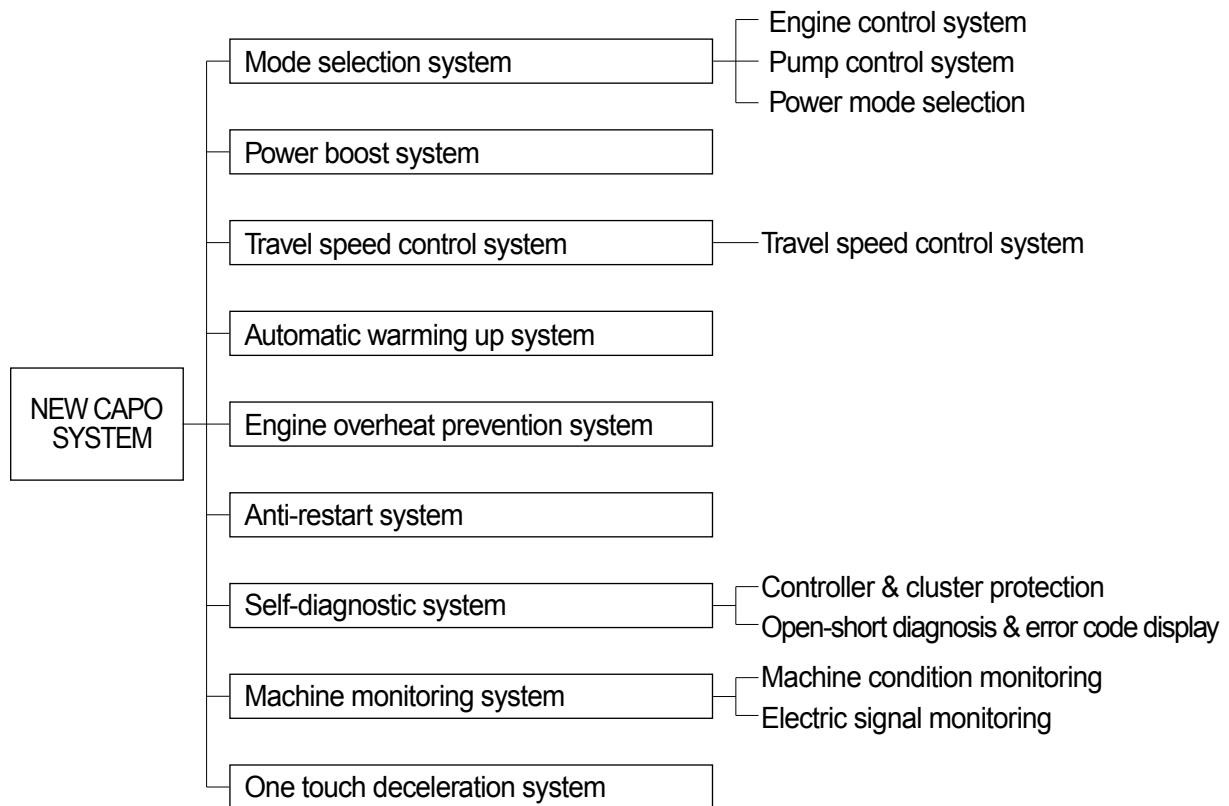

SYSTEM DIAGRAM

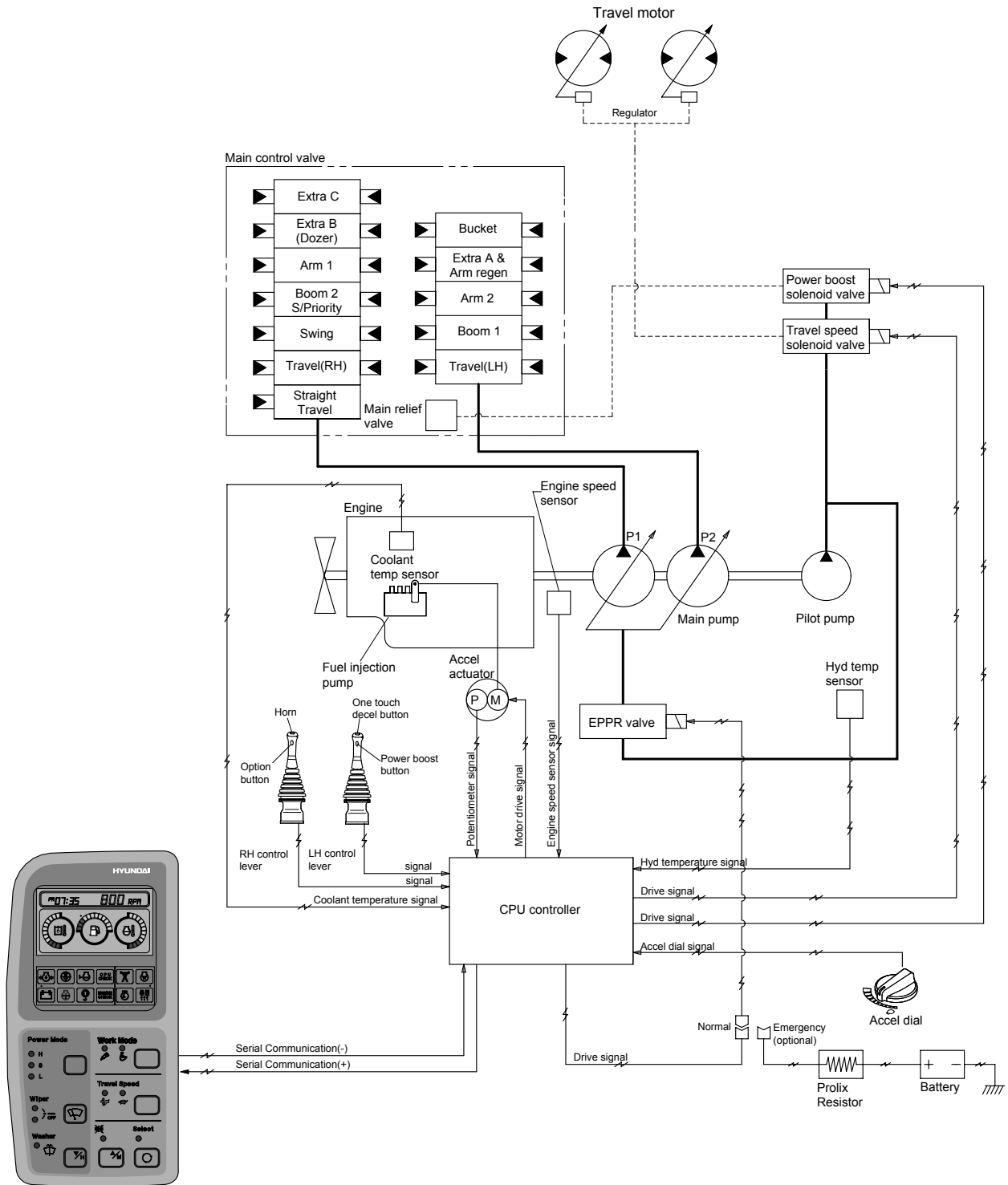

RD11075MS01

GROUP 2 MODE SELECTION SYSTEM

1. POWER MODE SELECTION SYSTEM

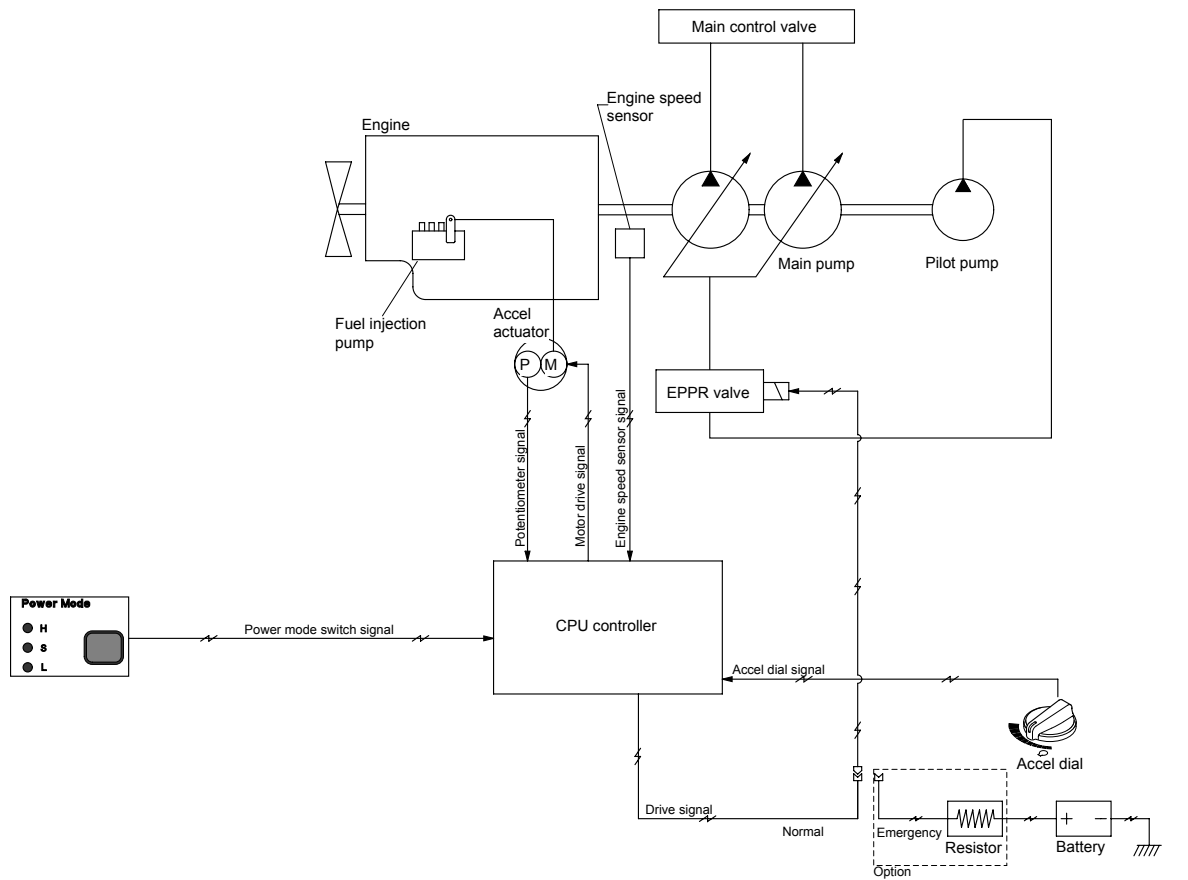

11075MS02

Mode selection system(Micro computer based electro-hydraulic pump and engine mutual control system) optimizes the engine and pump performance.

The combination of 3 power modes(H, S, L) and accel dial position(10 set) makes it possible to use the engine and pump power more effectively corresponding to the work conditions from a heavy and great power requesting work to a light and precise work.

Mode	Application	Power set (%)	Engine rpm		Power shift by EPPR valve			
					Default		Other case ※	
			Unload	Load	Current (mA)	Pressure (kgf/cm ²)	Current (mA)	Pressure (kgf/cm ²)
H	High power	100	1900±50	1800	245±30	4.1	245	4.1
S	Standard power	85	1800±50	1700	290±30	7.5	318	8.8
L	Light power	70	1750±50	1650	370±30	14.5	439	17.4
One touch decel	Engine quick deceleration	-	1050±100	-	650±30	46	650±30	40
KEY START	Key switch start position	-	1050±100	-	650±30	40	650±30	40

※ Other case can be set by pressing the "travel speed" switch and "buzzer stop switch" for 2 seconds at the same time in "model & version" display on the cluster(for detail, see 5-17)

GROUP 3 POWER BOOST SYSTEM

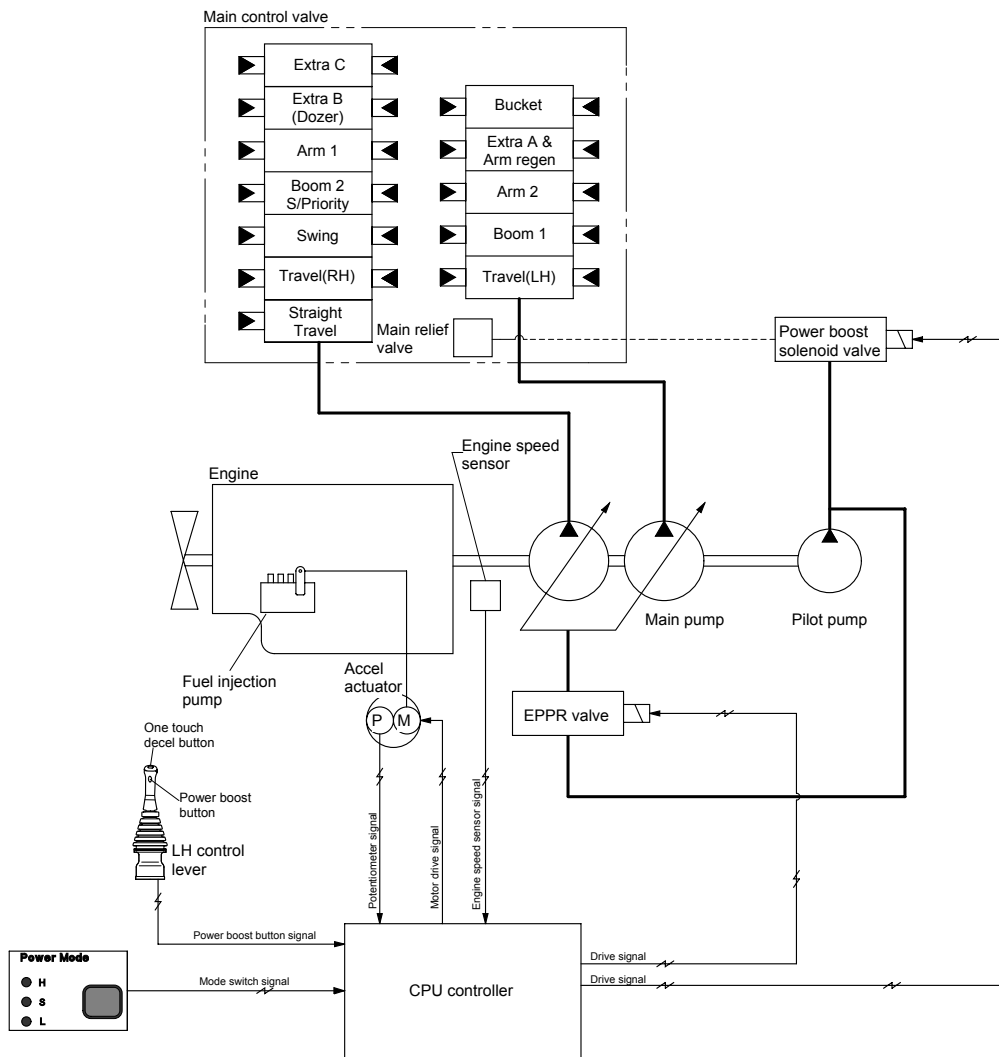

11075MS03

- When the power boost switch on the left control lever knob is pushed ON, the maximum digging power is increased by 10%.
- When the power set is at H or S and the power boost function is activated, the power boost solenoid valve pilot pressure raises the set pressure of the main relief valve to increase the digging power.

Description	Power boost switch	
	OFF	ON
Power set	H or S	H
Main relief valve set pressure	330kgf/cm ²	360ksf/cm ²
Time of operation	-	Even when pressed continuously, it is canceled after 8 sec.

※ Default - Power boost solenoid valve : OFF

GROUP 4 TRAVEL SPEED CONTROL SYSTEM

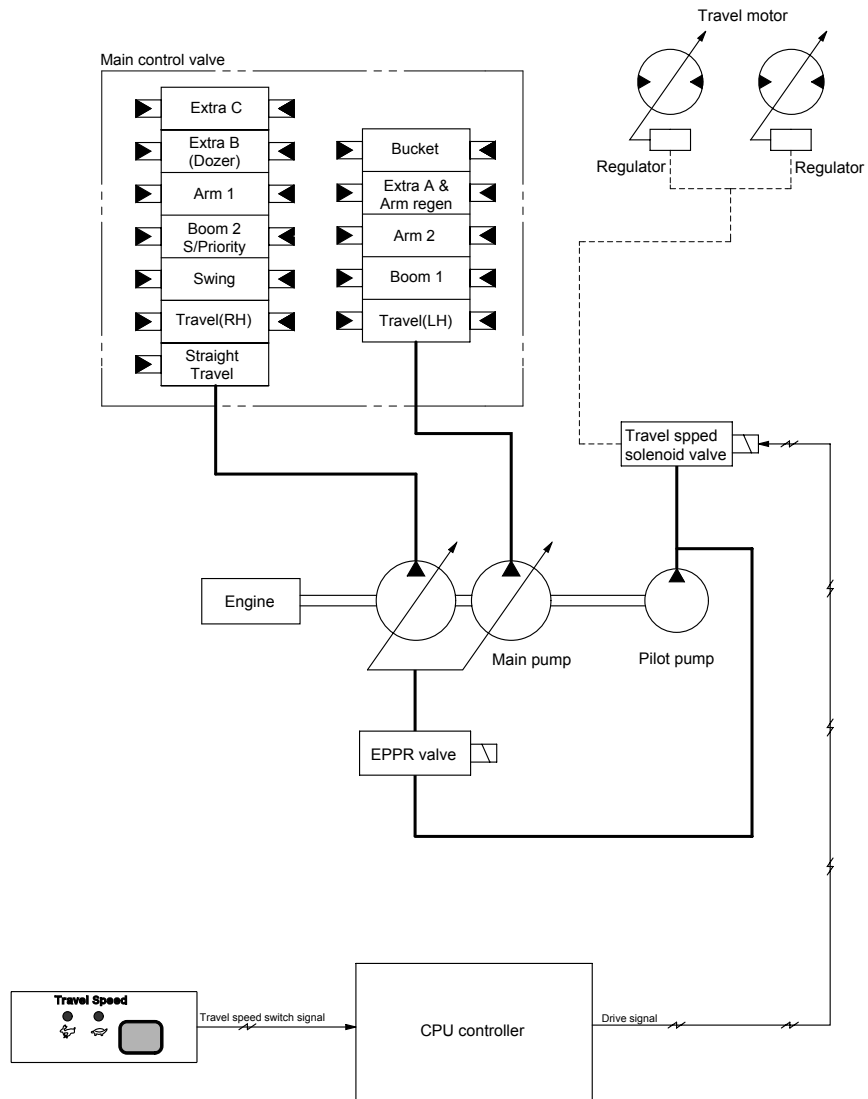

11075MS04

Travel speed can be switched manually by pressing the travel speed switch on the cluster.

Speed	Travel speed solenoid valve	Lamp on cluster	Operation
Lo	OFF	Turtle	Low speed, high driving torque in the travel motor
Hi	ON	Rabbit	High speed, low driving torque in the travel motor

※ Default : Turtle(Lo)

GROUP 5 AUTOMATIC WARMING UP FUNCTION

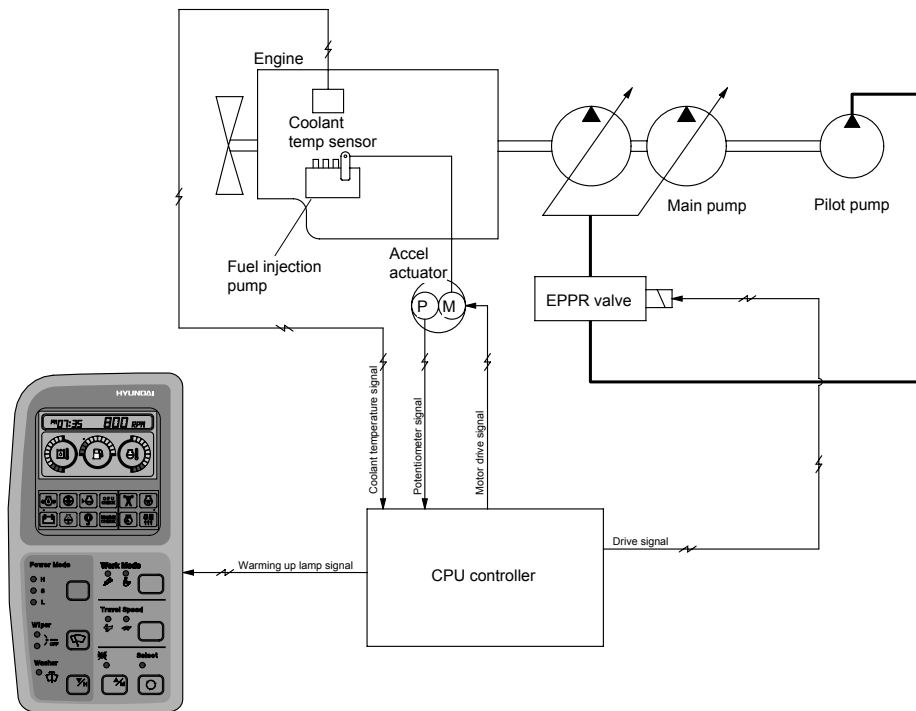

RD11075MS05

1. CPU controller reads engine coolant temperature through the temperature sensor, and if the coolant temperature is less than 30°C, it increases the engine speed from key start rpm to 1200rpm.
2. In case of the coolant temperature increases up to 30°C, the engine speed is decreased to key start speed. And if an operator changes mode set during the warming up function, the CPU controller cancels the automatic warming up function.

3. LOGIC TABLE

Description	Condition	Function
Actuated	- Coolant temperature : Less than 30°C(After engine run) - Accel dial position is under 3	- Mode : Default(S mode) - Warming up time : 10 minutes(Max) - Warming up lamp : ON
Canceled	- Coolant temperature : Above 30°C - Warming up time : Above 10 minutes - Changed mode set by operator - Increase engine speed by rotating accel dial clockwise ※ If any of the above conditions is applicable, the automatic warming up function is canceled	- Default mode - Default mode - Changed mode
Warming up lamp	- Coolant temperature : Above 30°C	- Warming up lamp : OFF

GROUP 6 ENGINE OVERHEAT PREVENTION FUNCTION

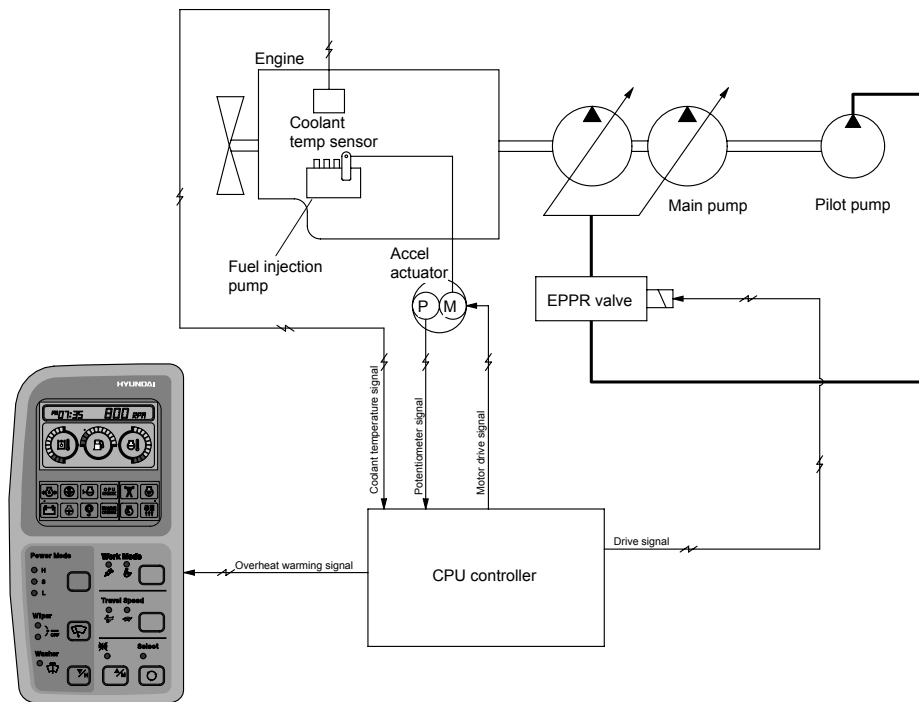

RD11075MS06

1. CPU controller reads engine coolant temperature through the temperature sensor and when the engine coolant boils up to 110°C, it sends overheat warning signal to the cluster and decrease the engine speed same as accel dial 7 position.
2. If the coolant temperature drops less than 100°C, the CPU controller returns the mode to the mode set before. And if mode set is changed during the function, the CPU controller cancels the function. Even if the overheat prevention function is canceled by mode change, the overheat warning lamp turns OFF only when the coolant temperature is less than 100°C.

3. LOGIC TABLE

Description	Condition	Function
Actuated	- Coolant temperature : Above 110°C - Accel dial set : Above 8	- Engine rpm drop to accel dial 7 position - Overheat warning lamp & buzzer : ON
Canceled	- Coolant temperature : Less than 100°C - Changed mode set by operator ※ If any of the above conditions is applicable, engine overheat prevention function is canceled	- Return to the mode and accel dial set before - Hold on the changed set
Overheat warning lamp	- Coolant temperature : Less than 100°C	- Overheat warning lamp : OFF

GROUP 7 ANTI-RESTART SYSTEM

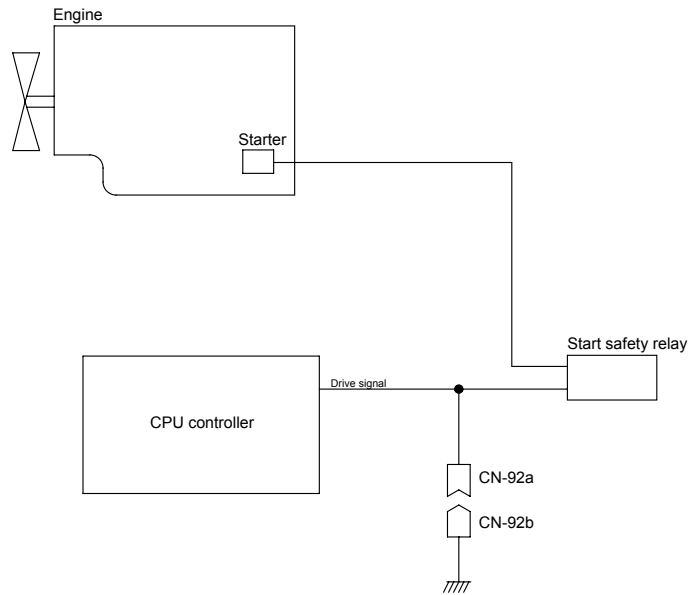

21075MS10

1. ANTI-RESTART FUNCTION

After 10 seconds from the engine starts to run, CPU controller turns off the start safety relay to protect the starter from inadvertent restarting.

2. When a replacement or taking-off of the CPU controller is needed, connect CN-92a and CN-92b to ensure the engine start without the CPU controller.

GROUP 8 SELF-DIAGNOSTIC SYSTEM

1. OUTLINE

When any abnormality occurs in the NEW CAPO system caused by electric parts malfunction and by open or short circuit, the CPU controller diagnoses the problem and sends the error codes to the cluster and also stores them in the memory.

The current or recorded error codes are displayed at the error display mode selected by touching **SELECT** switch 2 times while pressing **BUZZER STOP** switch.

2. CURRENT ERROR DISPLAY

Cluster displays **Co : Err** and makes buzzer sound itself to warn the communication error when communication problem caused by wire-cut or malfunction of the CPU controller occurs.

Cluster displays real time error codes received from CPU controller through communication. In case of no problem it displays **CHECK Er : 00**.

If there are more than 2 error codes, each one can be displayed by pressing ▲ and ▼ switch respectively.

Examples :

1) Communication Error

Co : Err & Buzzer sound

2) No problem

CHECK Er : 00

3) 4 Error codes(03, 06, 10, 43) display

CHECK Er : 03

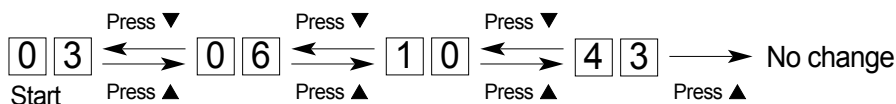

3. RECORDED ERROR DISPLAY



The recorded error can be displayed only when the key switch is at ON position.

Examples : 5 Recorded error codes(03, 06, 10, 20, 32) display

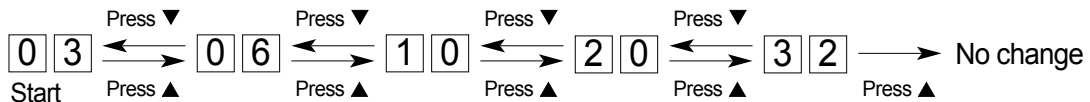
TIME Er : 03



4. DELETE ALL RECORDED ERROR CODES

Select recorded error(TIME Er) display and press engine  and select switch  at the same time for 2 seconds or more. Cluster display changes to **TIME Er : 00**, which shows that CPU controller deleted all the recorded error codes in the memory.

5. ERROR CODES TABLE

Fault code No.	Description
00	No error
01	Short circuit in accel actuator motor system
02	Potentiometer circuit is shorted to Vcc(5V) or battery +
03	Short circuit in pump EPPR valve system
05	Short circuit in travel speed solenoid system
10	Short circuit in hour-meter system
11	Accel dial circuit is shorted to Vcc(5V) or battery +
16	Accel actuator motor circuit is open or shorted to ground
17	Potentiometer circuit is open or shorted to ground
18	Pump EPPR valve circuit is open or shorted to ground
20	Travel speed solenoid circuit is open or shorted to ground
25	Hour-meter circuit is open or shorted to ground
26	Accel dial circuit is open or shorted to ground
31	Engine preheater circuit is open or shorted to ground
33	Alternator circuit is open or shorted to ground
34	Actuator input voltage is below 18V
35	Actuator input voltage is over 38V
36	Communication error with cluster
37	Engine speed sensor circuit is open or shorted to ground
40	There is more than 500rpm difference between target speed and actual speed
41	Hydraulic oil temperature sensor circuit is shorted to ground
42	Fuel level sensor circuit is shorted to ground
43	Coolant temperature sensor circuit is shorted to ground
45	Hydraulic oil temperature sensor circuit is open or shorted to battery +
46	Fuel level sensor circuit is open or shorted to battery +
47	Coolant temperature sensor circuit is open or shorted to battery +
49	Engine preheater circuit is shorted to battery +

GROUP 9 ENGINE CONTROL SYSTEM

1. CPU CONTROLLER MOUNTING

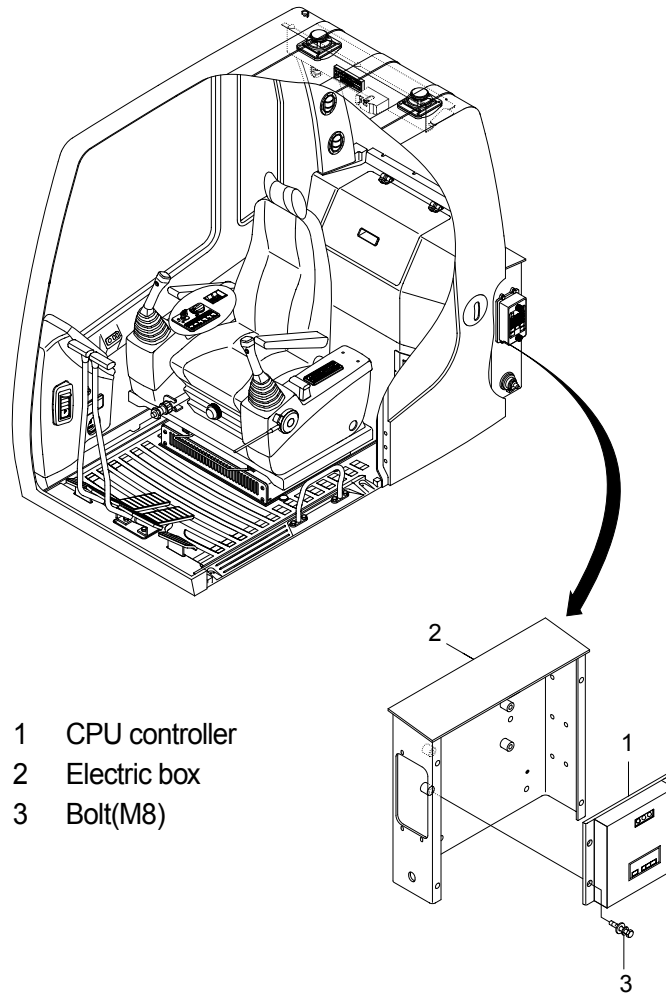

11075MS12

2. CPU CONTROLLER ASSEMBLY

- 1) Remove four pieces of bolt(3) of electric box(2).
- 2) Disconnect 2 connectors from CPU controller.
- 3) Remove 6 pieces of screw and open the cover of CPU controller.
- 4) Inspection : Check PCB(Printed Circuit Board)
 - (1) If any damage is found, replace CPU controller assembly.
 - (2) If not, but CAPO system does not work please report it to HHI dealer or A/S department.

3. EXCHANGE METHOD OF THE ROM

- 1) Disassemble the ash tray(2).
- 2) Disassemble the wiper motor cover(3).
- 3) Disassemble the cluster(1).

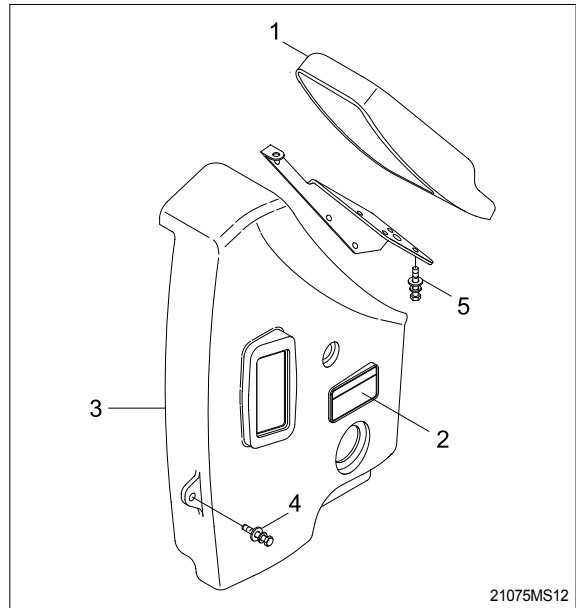

- 4) Loosen the screws(6EA) located back of the cluster.
- 5) Then you can open the upper case of the cluster easily.

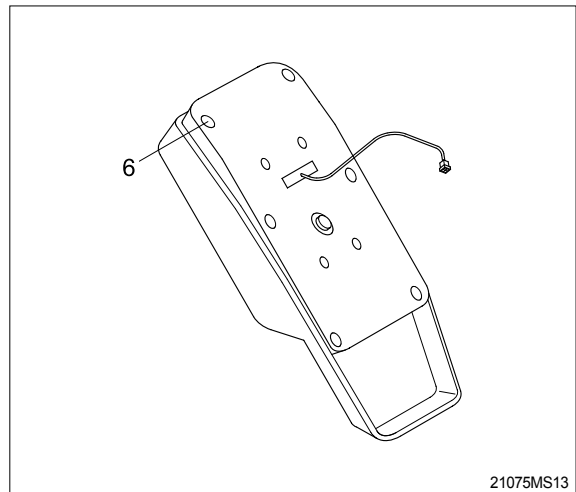

- 6) Install the new ROM.(Be careful of direction and assmelbe the cluster in the reverse order to removal).

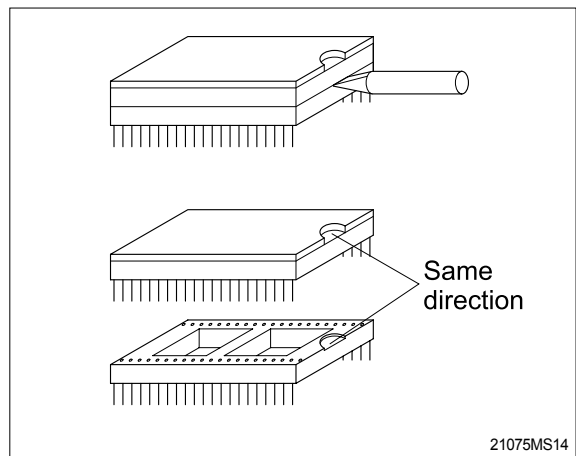

4. ENGINE ACCEL ACTUATOR

1 Accel actuator

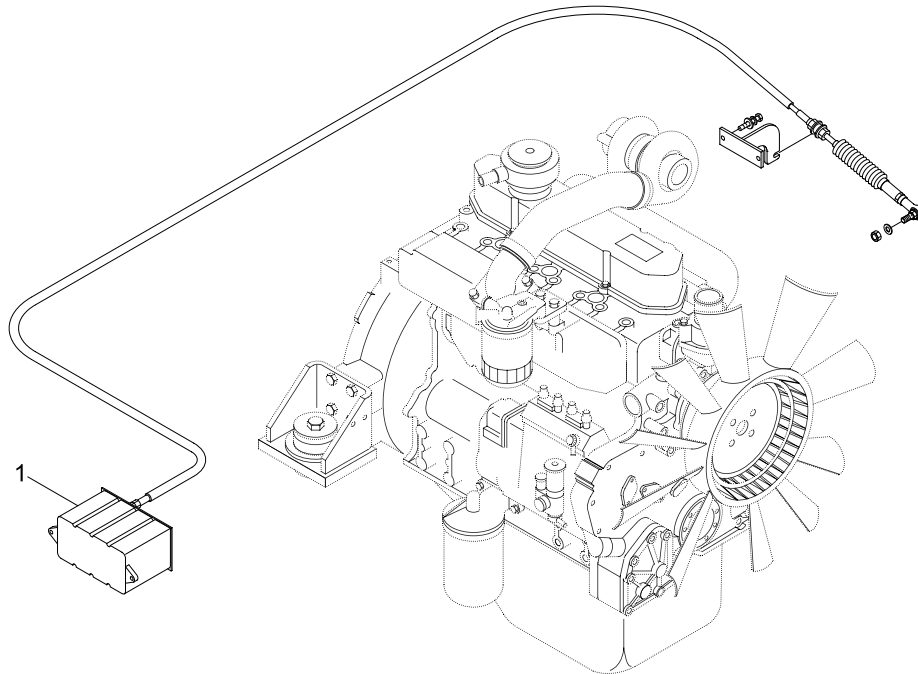

RD8075MS07

1) ENGINE THROTTLE LEVER

SL : Stopper, low idle
SH : Stopper, high idle

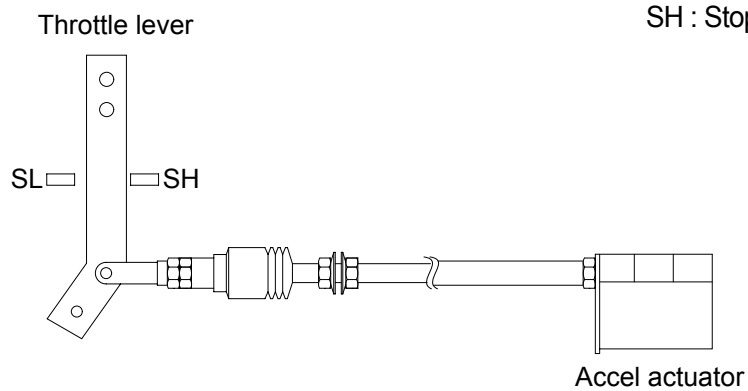

11075MS08

2) ACCEL ACTUATOR

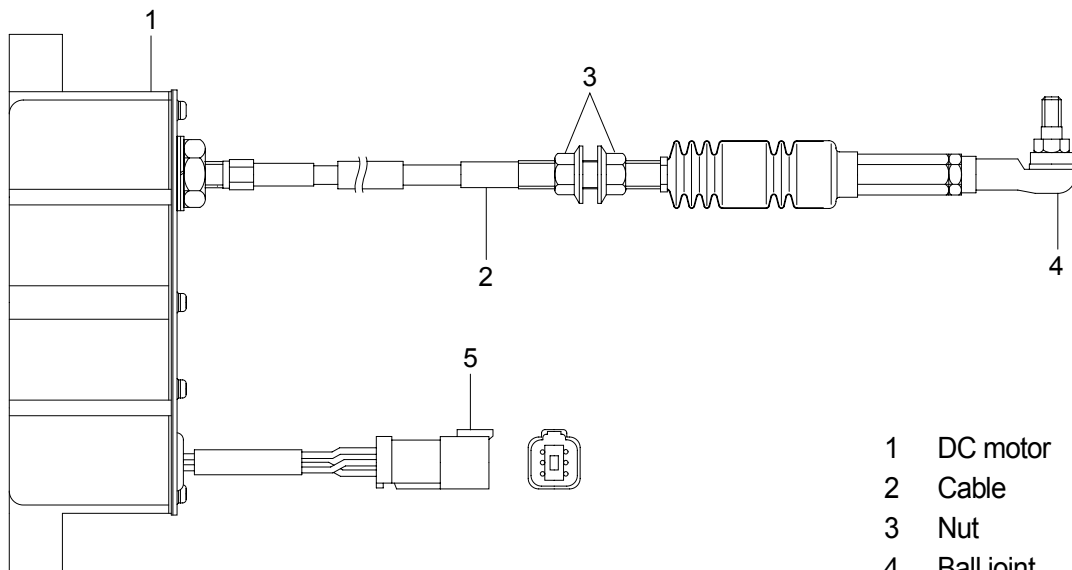

- 1 DC motor
- 2 Cable
- 3 Nut
- 4 Ball joint
- 5 Connector

11075MS09

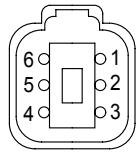
Connector		
Type	6P, female	
Line color & description	1	Green(Potentiometer 5V)
	2	White(Potentiometer SIG)
	3	Yellow(Potentiometer GND)
	4	-
	5	Red(Motor+)
	6	Blue(Motor -)
Inspection	Check resistance Spec : 10 Ω (Between No.5-6) 5kΩ (Between No.1-3)	

4) ACCEL ACTUATOR CABLE SETTING PROCEDURE

(1) Key ON

- ① Set the engine control dial max position and the one touch decel switch OFF.
- ② Connect the ball joint of cable to engine throttle lever.
- ③ Pull the cable to high stopper and put nut **A** edge to yoke of the bracket.
- ※ Make throttle lever not contact to the edge of high stopper.

(2) Key START

- ④ Confirm if the engine speed on cluster is same as each mode specification.
- ⑤ If the engine speed displayed on cluster is higher than each mode specification, then turn the nut **A** to counter clockwise and make the engine speed same to each mode specification.
- ⑥ If the engine speed displayed on cluster is lower than each mode specification, then turn the nut **A** to clockwise and make the engine speed same to each mode specification.
- ⑦ Turn nut **B** to clockwise and fix the cable to bracket.

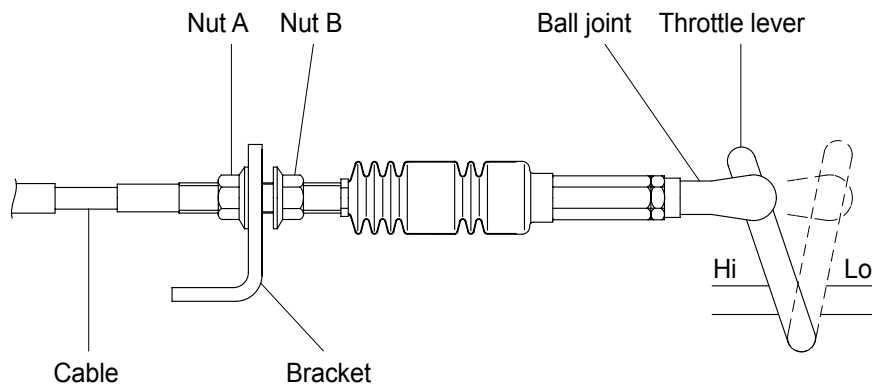

130W5MS05

Mode	RPM
H	1900 ± 50
S	1800 ± 50
L	1750 ± 50
Key start(one touch decel)	1050 ± 100

5. ENGINE SPEED SENSOR

1) DETECT ACTUAL ENGINE RPM AND SEND SIGNAL TO TACHOMETER

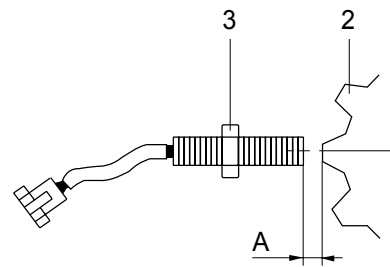
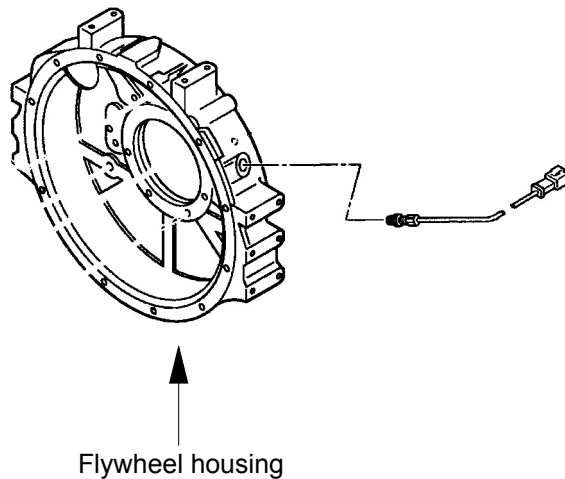

- 2 Gear teeth, flywheel
- 3 Lock nut, speed sensor
- A Clearance

11075MS10/R140LC-7 기타 5-20

2) INSTALLATION

- (1) Clean contacting point of sensor.
- (2) Loosen lock nut.
- (3) Screw speed sensor into flywheel housing.
- (4) Turn it back 135° when it contacts with gear teeth.
- (5) Tight lock nut and connect wiring.

3) INSPECTION

- (1) Check resistance
 - SPEC : 300 Ω
- (2) Check voltage while engine run.
 - SPEC : 2~28Vac, dependent on the engine speed(rpm)

GROUP 10 EPPR VALVE

1. COMPOSITION OF EPPR VALVE

EPPR(Electro Proportional Pressure Reducing) valve consists of electro magnet and spool valve installed at main hydraulic pump.

1) ELECTRO MAGNET VALVE

Receive electric current from CPU controller and move the spool proportionally according to the specific amount of electric current value.

2) SPOOL VALVE

Is the two way direction control valve for pilot pressure to reduce hydraulic pump flow.

When the electro magnet valve is activated, pilot pressure enters into flow regulator of hydraulic pump. So, pump flow decreases to prevent engine stall.

3) PRESSURE AND ELECTRIC CURRENT VALUE FOR EACH MODE

Mode		Pressure		Electric current (mA)	Engine rpm (At accel dial 10)
		kgf/cm ²	psi		
Standard (Ver : 1.x)	H	5 ± 3	71 ± 40	245 ± 30	1900 ± 50
	S	11 ± 3	156 ± 40	290 ± 30	1800 ± 50
	L	17 ± 3	242 ± 40	370 ± 30	1750 ± 50
Option (Ver : 2.x)	H	5 ± 3	71 ± 40	245 ± 30	1950 ± 50
	S	11 ± 3	156 ± 40	318 ± 30	1850 ± 50
	L	14 ± 3	199 ± 40	439 ± 30	1750 ± 50
★		19.8 ± 3	280 ± 40	471 ± 30	-



★ Manually operated condition when prolix switch is selected emergency position.

2. HOW TO SWITCH THE VERSION(1.x ↔ 2.x) ON THE CLUSTER

You can switch the EPPR valve pressure set by selecting the version(1.x ↔ 2.x).

Step 1. Turn the key switch **ON**.

Step 2. Press the **SELECT** switch 3 times.

Step 3. While 7 segment on the cluster shows the version of the CPU controller program, for example **11:C1.0** press the buzzer stop switch() + travel speed control switch() at the same time for 2 seconds.

The display changes to **11:C2.0**, and it indicates that version 2.0(Option) is selected.

※ If you want to get back to ver:1.x, go to step 1~3.

2. OPERATING PRINCIPLE

1) STRUCTURE

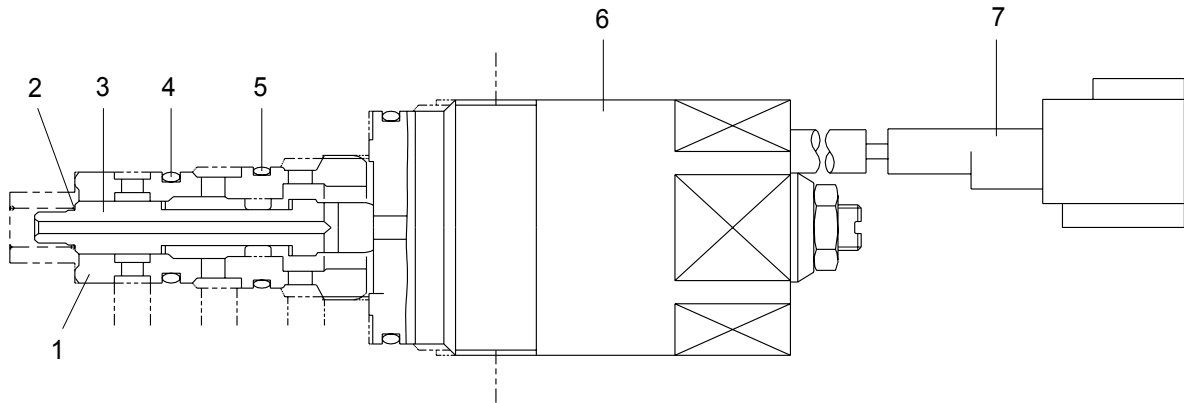

R140LC-7 기타 5-22(1)

- | | | |
|----------|----------|------------------|
| 1 Sleeve | 4 O-ring | 6 Solenoid valve |
| 2 Spring | 5 O-ring | 7 Connector |
| 3 Spool | | |

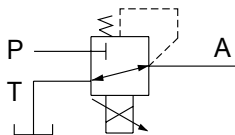

- P Pilot oil supply line(Pilot pressure)
 T Return to tank
 A Secondary pressure to flow regulator at hydraulic pump

2) AT H MODE

Pressure line is blocked and A oil returns to tank.

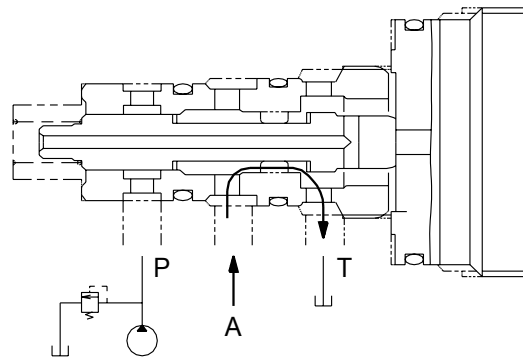
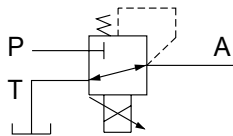

3) AT S MODE

Secondary pressure enters into A.

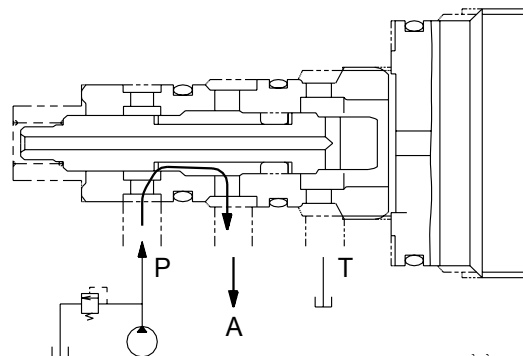
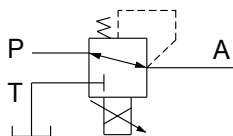

R140LC-7 기타 5-22(2)

3. EPPR VALVE CHECK PROCEDURE

1) CHECK ELECTRIC VALUE AT EPPR VALVE

- (1) Start engine.
- (2) Set S-mode and cancel auto decel mode.
- (3) Position the accel dial at 10.
- (4) If tachometer show approx 1950 ± 50 rpm, disconnect one wire harness from EPPR valve.
- (5) Install multimeter as figure.
- (6) Check electric current at bucket circuit relief position.

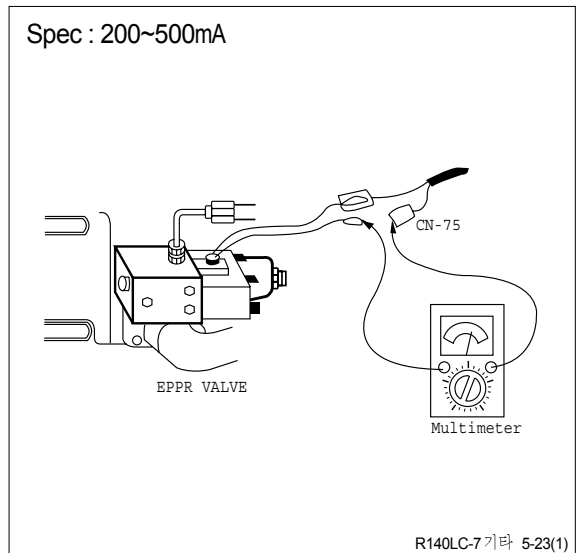

2) CHECK PRESSURE AT EPPR VALVE

- (1) Remove plug and connect pressure gauge as figure.
 - Gauge capacity : 0 to 40-50kgf/cm²
(0 to 580-725psi)
- (2) Start engine.
- (3) Set S-mode and cancel auto decel mode.
- (4) Position the accel dial at 10.
- (5) If tachometer show approx 1950 ± 50 rpm, check pressure at relief position of bucket circuit by operating bucket control lever.
- (6) If pressure is not correct, adjust it.
- (7) After adjust, test the machine.

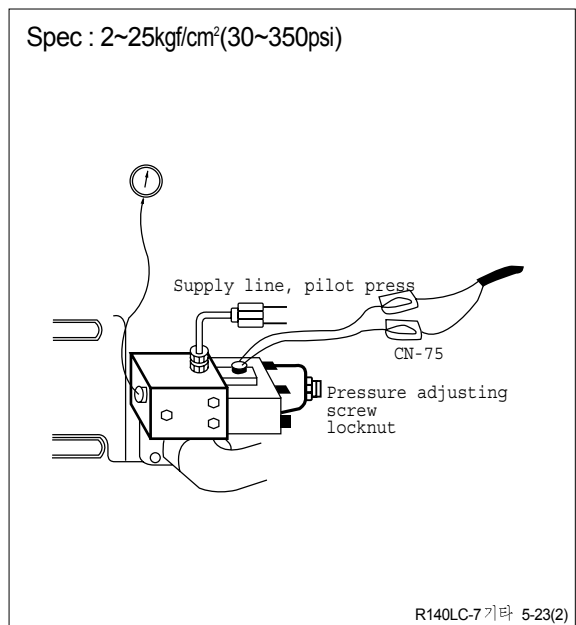

GROUP 11 PUMP PROLIX

Its the conversion connector to manual control temporarily when the electronic control system is out of order, until repair work be done.

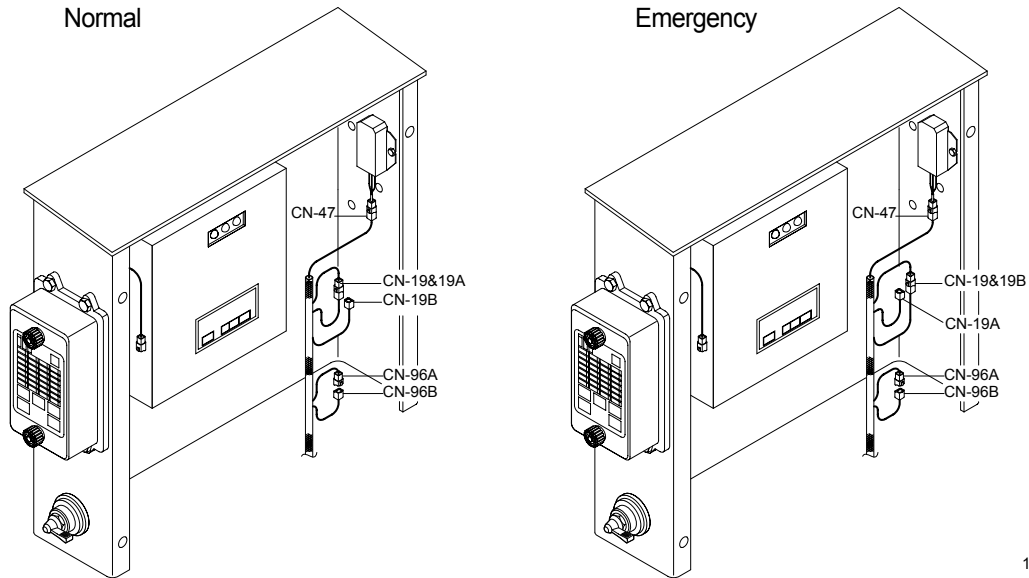

16075MS12

1. OPERATING PRINCIPLE WIRING DIAGRAM

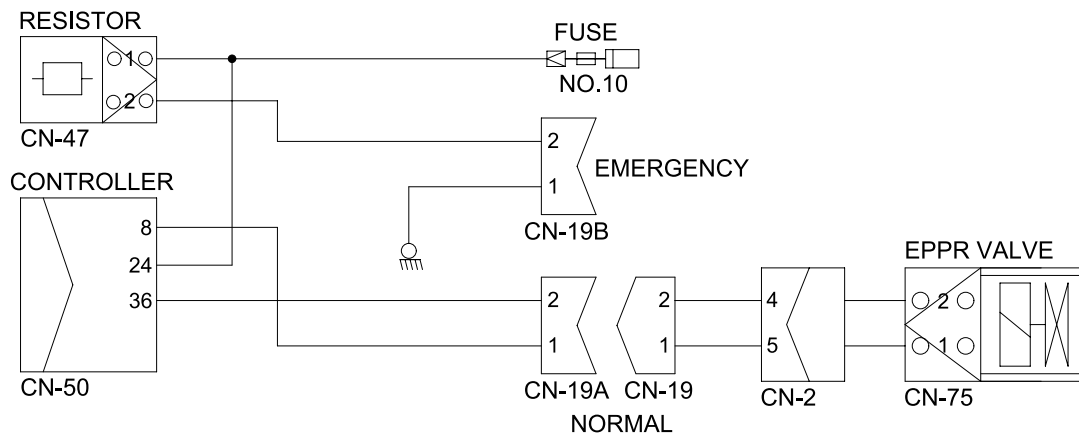

16075MS30

1) NORMAL

- EPPR valve supply specified amount of pilot pressure to the flow regulator of hydraulic pump and regulate hydraulic pump delivery amount depending upon the signal of CPU controller by selected mode.

2) EMERGENCY

- If prolux resistor(CN-19) is connected with CN-19B when any abnormality occurs in NEW CAPO system, constant electric current from battery flows to EPPR valve so that EPPR valve can be fixed at the predetermined position.
- In this case excavator can be operated at an equivalent performance to S mode.

GROUP 12 MONITORING SYSTEM

1. OUTLINE

Monitoring system consists of the monitor part and switch part.

The monitor part gives warnings when any abnormality occurs in the machine and informs the condition of the machine.

Various select switches are built into the monitor panel, which act as the control portion of the machine control system.

2. CLUSTER

1) MONITOR PANEL

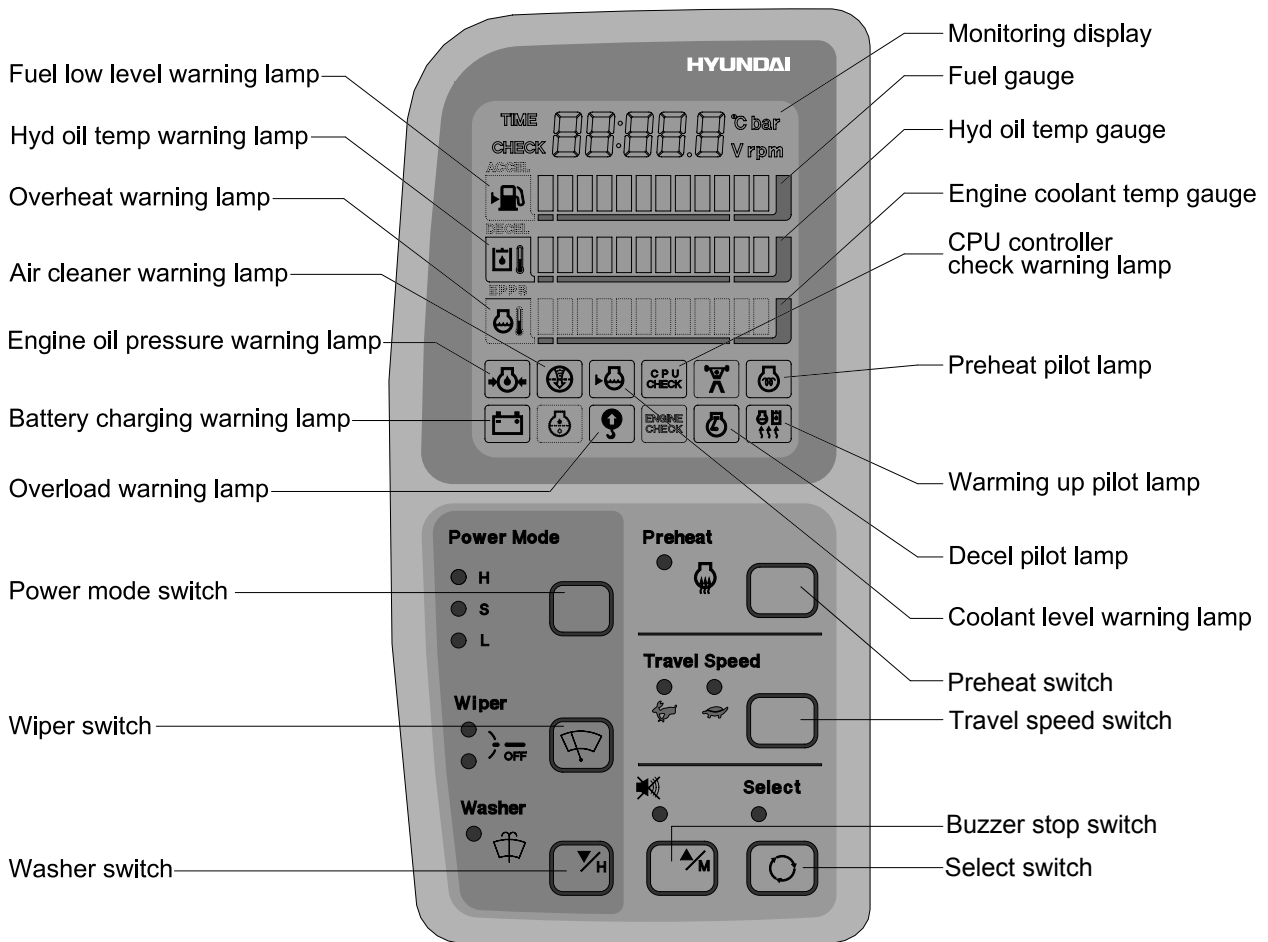

7075MS11

2) CLUSTER CHECK PROCEDURE

(1) Start key : ON

- ① Check monitor initial 5 seconds
 - a. All lamps light up.
 - b. Buzzer sound.
- ② Check monitor after 5 seconds : Indicate cluster version and machine condition
 - a. Cluster program version : CL : 2.0 ← Indicates program version 2.0 for 2 seconds.
 - b. Tachometer : 0rpm
 - c. Fuel gauge : All light up below appropriate level
 - d. Hydraulic temperature : All light up below appropriate level
 - e. Engine coolant temperature gauge : All light up below appropriate level
 - f. Warning lamp
 - ※ During start key **ON** the engine oil pressure lamp and battery charging lamp go on, but it is not abnormal.
 - ※ When engine coolant temperature below 30°C, the warming up lamp lights up.
- ③ Indicating lamp state
 - a. Power mode selection : S mode
 - b. Preheat : No LED ON
 - c. Wiper : No LED ON
 - d. Washer : No LED ON
 - e. Travel speed pilot lamp : Low(Turtle)

(2) Start of engine

- ① Check machine condition
 - a. Tachometer indicates at present rpm
 - b. Gauge and warning lamp : Indicate at present condition.
 - ※ When normal condition : All warning lamp OFF
 - c. Preheat : No LED ON
 - d. Power mode selection : S mode
 - e. Wiper : No LED ON
 - f. Washer : No LED ON
 - g. Travel speed pilot lamp : Low(Turtle)
- ② When warming up operation
 - a. Warming up lamp : ON
 - b. 10 seconds after engine started, engine speed increases to 1200 rpm
 - ※ Others same as above ①.
- ③ When abnormal condition
 - a. The lamp lights up and the buzzer sounds.
 - b. If **BUZZER STOP** switch is pressed, buzzer sound is canceled but the lamp light up until normal condition.

3. CLUSTER CONNECTOR

No.	Signal	Input / Output
1	Power IG(24V)	Input(20~32V)
2	GND	Input(0V)
3	Serial-(RX)	Input(Vpp=12V)
4	Serial+(TX)	Output(Vpp=4V)

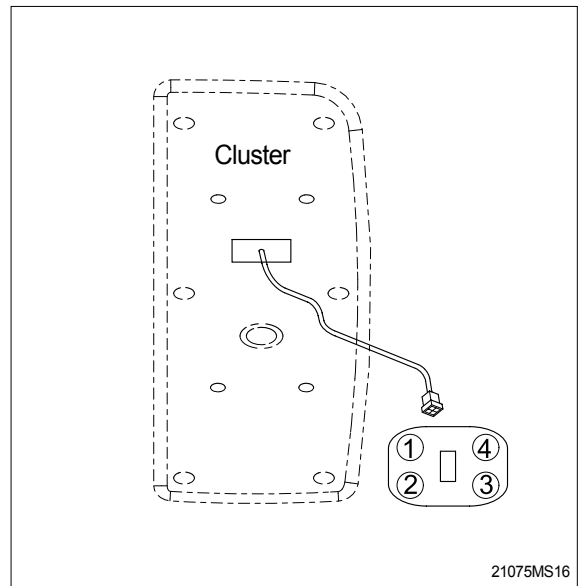

4. CLUSTER FUNCTION

1) MONITORING DISPLAY

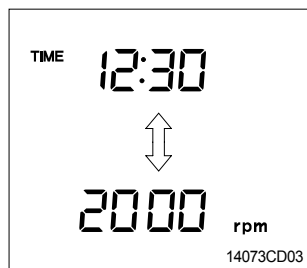



- ① This displays the current time and machine information such as engine rpm, coolant/hydraulic oil temperature, hydraulic oil pressure and also error codes.

※ Refer to the page 5-24 for details.

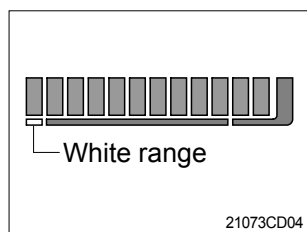
2) FUEL GAUGE



- ① This gauge indicates the amount of fuel in the fuel tank.
- ② Fill the fuel when the white range or warning lamp  blinks.

※ If the gauge illuminates the white range or warning lamp  blinks even though the machine is on the normal condition, check the electric device as that can be caused by the poor connection of electricity or sensor.

3) HYDRAULIC OIL TEMPERATURE GAUGE

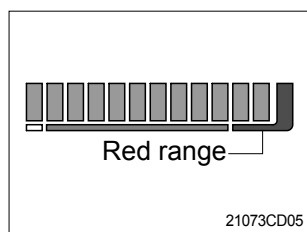

- ① This indicates the temperature of coolant.
 - White range : 30°C(86°F) below
 - Green range : 30-105 °C(86-221°F)
 - Red range : 105°C(221°F) above
- ② The green range illuminates when operating.
- ③ Keep idling engine at low speed until the green range illuminates, before operation of machine.
- ④ When the red range illuminates, reduce the load on the system. If the gauge stays in the red range, stop the machine and check the cause of the problem.

4) ENGINE COOLANT TEMPERATURE GAUGE

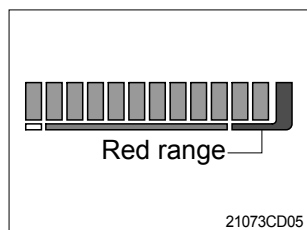

- ① This indicates the temperature of coolant.
 - White range : 30°C(86°F) below
 - Green range : 30-105 °C(86-221°F)
 - Red range : 105°C(221°F) above
- ② The green range illuminates when operating.
- ③ Keep idling engine at low speed until the green range illuminates, before operation of machine.
- ④ When the red range illuminates, turn OFF the engine, check the radiator and engine.

5) FUEL LOW LEVEL WARNING LAMP



21073CD04A

- ① This lamp blinks and the buzzer sounds when the level of fuel is below 21.5 l (5.7U.S. gal).
- ② Fill the fuel immediately when the lamp blinks.

6) HYDRAULIC OIL TEMPERATURE WARNING LAMP

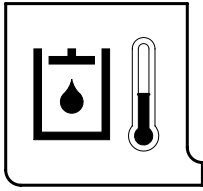

21073CD05A

- ① This warning lamp operates and the buzzer sounds when the temperature of hydraulic oil is over 105 °C (221 °F) .
- ② Check the hydraulic oil level when the lamp blinks.
- ③ Check for debris between oil cooler and radiator.

7) OVERHEAT WARNING LAMP

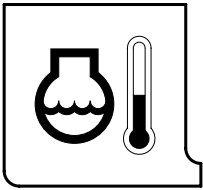

21073CD06A

- ① This lamp blinks and the buzzer sounds when the temperature of coolant is over the normal temperature 110°C (230°F) .
- ② Check the cooling system when the lamp blinks.

8) ENGINE OIL PRESSURE WARNING LAMP

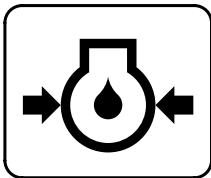

21073CD07

- ① This lamp blinks and the buzzer sounds after starting the engine because of pressure.
- ② If the lamp blinks during engine operation, shut OFF engine immediately. Check oil level.

9) AIR CLEANER WARNING LAMP

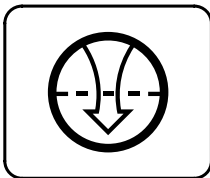

21073CD08

- ① This lamp is operated by the vacuum caused inside when the filter of air cleaner is clogged which supply air to the engine.
- ② Check the filter and clean or replace it when the lamp blinks.

10) COOLANT LEVEL WARNING LAMP

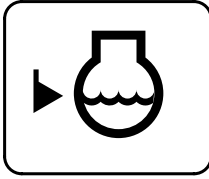

21073CD09

- ① This lamp blinks and the buzzer sounds when the coolant is below LOW in the reservoir tank of radiator.
- ② Check the reservoir tank when the lamp blinks.

11) CPU CONTROLLER CHECK WARNING LAMP

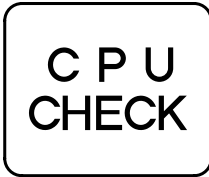

21073CD10

- ① Communication problem with CPU controller makes the lamp blinks and the buzzer sounds.
- ② With lamp blinks all of the lamp on the cluster LCD will be OFF.

12) BATTERY CHARGING WARNING LAMP

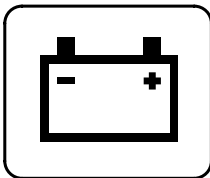

21073CD13

- ① This lamp blinks and the buzzer sounds when the starting switch is ON, it is turned OFF after starting the engine.
- ② Check the battery charging circuit when this lamp blinks, during engine operation.

13) OVERLOAD WARNING LAMP

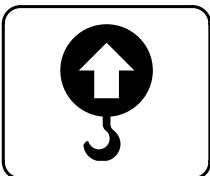

21073CD15

- ① When the machine is overload, the overload warning lamp blinks during the overload switch ON.

14) ONE TOUCH DECEL PILOT LAMP

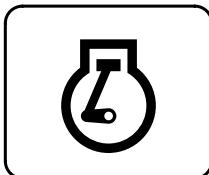

21073CD17

- ① Operating auto decel or one touch decel makes the lamp ON.
- ② The lamp will be ON when pushing one touch decel switch on the LH RCV lever.

15) WARMING UP PILOT LAMP

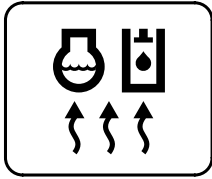

21073CD18

- ① This lamp is turned ON when the coolant temperature is below 30°C (86 °F).
- ② The automatic warming up is cancelled when the engine coolant temperature is above 30 °C, or when 10 minutes have passed since starting.

16) PREHEAT PILOT LAMP

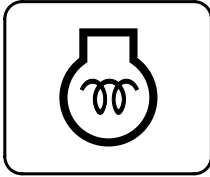

21073CD12

- ① This lamp is turned ON when the preheating function is actuated in cold weather.
- ② Start the engine as this lamp is OFF.

17) POWER MODE SWITCH

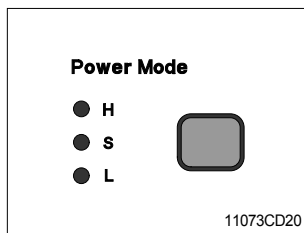

11073CD20

- ① This switch is to select the machine power mode, which shifts from high power work to standard power work and light power work in a row by pressing the switch.
 - **H** : This is used for high power work
 - **S** : This is used for standard power work
 - **L** : This is used for light power work

18) WIPER SWITCH

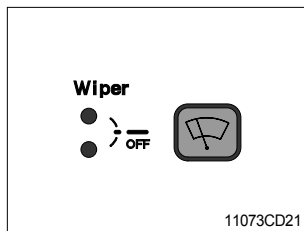

11073CD21

- ① This switch is used to operate wiper.
 - Press the switch once to operate wiper.
 - Press the switch once more to intermittently operate wiper low speed.
 - Press the switch more than one second to turn off wiper.
- ※ **Wiper motor doesn't operate with front sliding door open.**
- ※ **If wiper does not operate with the switch in the ON position, turn the switch off immediately. Check the cause. If the switch remains ON, it can result in motor failure.**

19) WASHER SWITCH

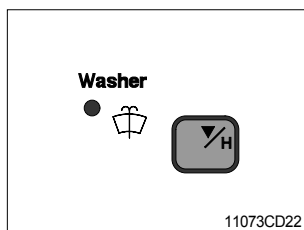

11073CD22

- ① The washer liquid is sprayed and the wiper is operated only while pressing this switch.
- ② The indicator lamp is turned ON when operating this switch.

20) PREHEAT SWITCH

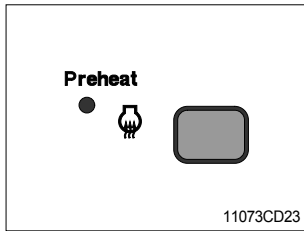

- ① This switch is used for starting the engine in cold weather. If pressed, grid heater is activated to get easier engine starting.
※ **Never hold the push button switch in for more than 30 seconds, as this can damage the grid heater.**
- ② The indicator lamp is turned ON when operating this switch.

21) TRAVEL SPEED CONTROL SWITCH

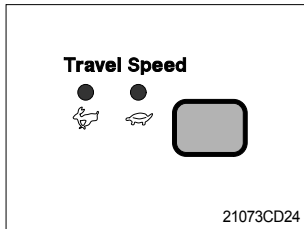

- ① This switch is to control the travel speed which is changed to high speed(Rabbit mark) by pressing the switch and low speed(Turtle mark) by pressing again.

22) BUZZER STOP SWITCH

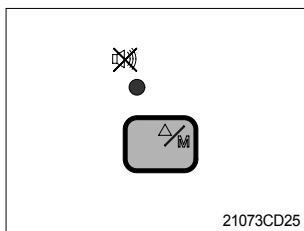

- ① When the starting switch is turned ON first, normally the alarm buzzer sounds for 5 seconds during lamp check operation.
- ② The red lamp lights ON and the buzzer sounds when the machine has a problem.
In this case, press this switch and buzzer stops, but the red lamp lights until the problem is cleared.

23) SELECT SWITCH

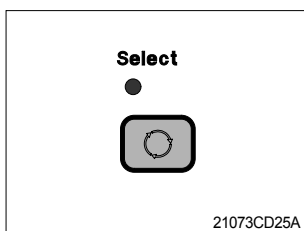

- ① This switch is used to select the monitor display function.
※ **Refer to the page 5-24 for details.**
- ② If the switch is pressed for 3 seconds in time display mode, it is selected time adjusting function, as below.
 - Hour by auto decel switch
 - Minute by buzzer stop switch.
- ③ After time set, the switch is pressed, it is returned clock.

5. MONITORING DISPLAY

1) OUTLINE

Information of machine performance as monitored by the CPU controller can be displayed on the cluster when the operator selects a display mode by touching **SELECT** switch alone or with **BUZZER STOP** switch on the cluster as below.

Display group	How to select display mode		Name	Display on the cluster
	Group selection	Display mode selection		
Group 0 (Default)	Way 1 Key switch ON or START Way 2 Touch WASHER switch while pressing BUZZER STOP at group 1~4.	Initial	Engine rpm	1750 rpm
		Touch SELECT 1 time	Time	TIME 12:30
		Touch SELECT 2 times	CPU model & version	08C 10
Group 1 (Volt, temp, EPPR press, version)	Touch SELECT switch once while pressing BUZZER STOP . In this group SELECT LED ON	Default	Battery voltage(V)	b:24.8v
		Touch SELECT 1 time	Potentiometer voltage(V)	Pa: 2.5v
		Touch SELECT 2 times	Accel dial voltage(V)	dL: 3.8v
		Touch SELECT 3 times	Hydraulic oil temperature(°C)	Hd: 105°C
		Touch SELECT 4 times	Coolant temperature(°C)	Ct: 107°C
Group 2 (Error code)	Touch SELECT switch twice while pressing BUZZER STOP . In this group BUZZER STOP LED blinks	Default	Current error	CHECK Er: 03
		Touch SELECT 1 time	Recorded error (Only key switch ON)	TIME Er: 03
		Press down(▼) & SELECT at the same time	Recorded error deletion (Only key switch ON)	TIME Er: 00
Group 3 (Switch input)	Touch SELECT switch 3 times while pressing BUZZER STOP . In this group SELECT LED blinks at 0.5sec interval	Default	One touch decel switch	o dion or oFF
		Touch SELECT 1 time	Preheat switch	PHion or oFF
		Touch SELECT 2 times	Overload pressure switch	o lion or oFF
Group 4 (Output)	Touch SELECT switch 4 times while pressing BUZZER STOP . In this group SELECT LED blinks at 1sec interval	Default	Hourmeter	Hoion or oFF
		Touch SELECT 1 time	Neutral relay (Anti-restart relay)	nrion or oFF
		Touch SELECT 2 times	Travel speed solenoid	SSion or oFF
		Touch SELECT 3 times	Preheat relay	PRion or oFF

※ By touching **SELECT** switch once while pressing **BUZZER STOP**, display group shifts.

Example : Group 0 → 1 → 2 → 3 → 4 → 0

2) DESCRIPTION OF MONITORING DISPLAY

Group	Display	Name	Description
Group 0	2200 rpm	Engine speed	It displays current engine speed detected by engine speed sensor from 500 to 3000rpm. Range : 500~3000rpm by 10rpm
	TIME 12 : 30	Time	It displays current time(12 is hour and 30 is minute) Range : Hour(1~12), minute(00~59)
	08 : C1.0	Model and CPU program version	It shows that machine model(R80-7) and the program version of the CPU controller is 1.0. Version display range : 0.0~9.9 by 0.1
Group 1	b24 : 8V	Battery voltage	It shows that battery power of 24.8V is supplied into CPU controller. Range : 00.0~48.0V by 0.1V
	Po : 2.5V	Potentiometer voltage	It shows that potentiometer signal voltage is 2.5V. Range : 0.0~5.0V by 0.1V
	dL : 3.8V	Accel dial voltage	It shows that accel dial signal voltage is 3.8V. Range : 0.0~5.0V by 0.1V
	Hd : 50°C	Hydraulic oil temperature	It shows that hydraulic oil temperature detected by temperature sensor is 50°C. Range : 0~150°C by 1°C
	Ct : 85°C	Coolant temperature	It shows that coolant oil temperature detected by temperature sensor is 50°C. Range : 0~150°C by 1°C
Group 2	CHECK Er : 01	Current error	It shows that current error of 01(Short circuit in accel actuator motor system) is diagnosed by self diagnosis system in the CPU controller. If more than 2 errors, when pressing ▼ or ▲ switch, other error codes show. Range : 00~58
	TIME Er : 03	Recorded error	It shows recorded error code of 03 which is diagnosed before. If more than 2 error codes, when pressing ▼ or ▲ switch, other error codes show. Range : 00~58
	TIME Er : 00	Recorded error deletion	It shows all recorded error codes are removed in the CPU controller memory.

Group	Display	Name	Description
Group 3	od : on or oFF	One touch decel switch	od : on Shows that one touch decel switch is pressed. od : oFF Shows that one touch decel switch is released.
	PH : on or oFF	Preheat switch	PH : on Shows that preheat switch is pressed. PH : oFF Shows that preheat switch is released.
	ol : on or oFF	Overload pressure switch	ol : on Shows that overload pressure switch is turned ON. ol : oFF Shows that overload pressure switch is turned OFF.
Group 4	Ho : on or oFF	Hourmeter	Ho : on Shows that hourmeter is activated by CPU controller. Ho : oFF Shows that hourmeter is turned off.
	nr : on or oFF	Neutral relay (Anti-restart relay)	nr : on Shows that neutral relay for anti-restarting function is activated(Engine start is possible). nr : oFF Shows that neutral relay is turned off to disable the engine restart.
	ts : on or oFF	Travel speed solenoid	ts : on Shows that travel speed solenoid is activated (High speed). ts : oFF Shows that travel speed solenoid is released (Low speed).
	PR : on or oFF	Preheat relay	PR : on Shows that preheat relay is activated. PR : oFF Shows that preheat relay is released.

■ MONITORING SYSTEM

1. OUTLINE

Monitoring system consists of the monitor part and switch part.

The monitor part gives warnings when any abnormality occurs in the machine and informs the condition of the machine.

Various select switches are built into the monitor panel, which act as the control portion of the machine control system.

2. CLUSTER

1) MONITOR PANEL

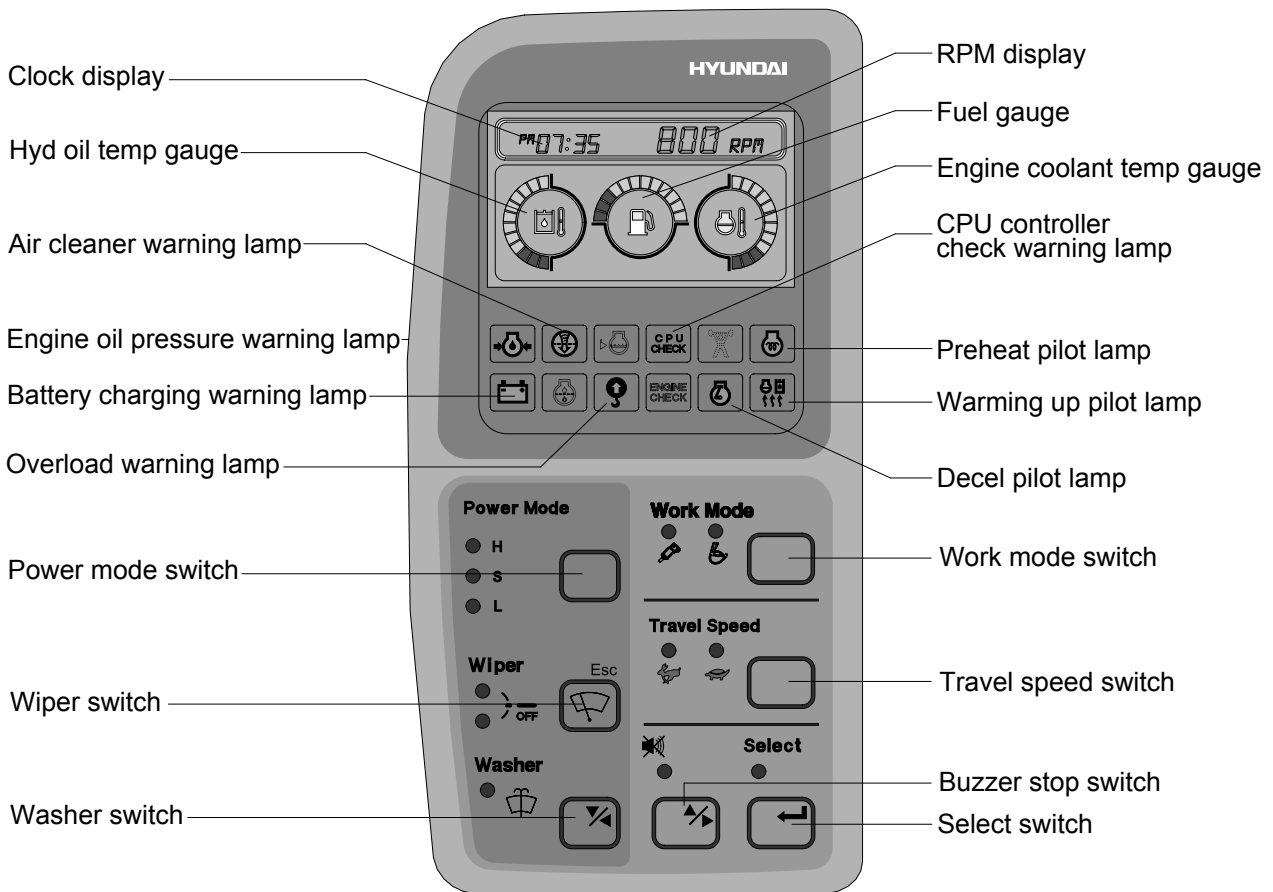

RD8075MS08

2) CLUSTER CHECK PROCEDURE

(1) Start key : ON

- ① Check monitor initial 5 seconds
 - a. All lamps light up.
 - b. Buzzer sound.
- ② Check monitor after 5 seconds : Indicate cluster version and machine condition
 - a. Cluster program version : 「1.00」 ← Indicates program version 「1.00」 for 5 seconds.
 - b. Tachometer : 0rpm
 - c. Fuel gauge : All light up below appropriate level
 - d. Hydraulic temperature : All light up below appropriate level
 - e. Engine coolant temperature gauge : All light up below appropriate level
 - f. Warning lamp
 - ※ During start key **ON** the engine oil pressure lamp and battery charging lamp go on, but it is not abnormal.
 - ※ When engine coolant temperature below 30°C, the warming up lamp lights up.
- ③ Indicating lamp state
 - a. Power mode selection : S mode
 - b. Preheat : No LED ON
 - c. Wiper : No LED ON
 - d. Washer : No LED ON
 - e. Travel speed pilot lamp : Low(Turtle)

(2) Start of engine

- ① Check machine condition
 - a. Tachometer indicates at present rpm
 - b. Gauge and warning lamp : Indicate at present condition.
 - ※ When normal condition : All warning lamp OFF
 - c. Preheat : No LED ON
 - d. Power mode selection : S mode
 - e. Wiper : No LED ON
 - f. Washer : No LED ON
 - g. Travel speed pilot lamp : Low(Turtle)
- ② When warming up operation
 - a. Warming up lamp : ON
 - b. 10 seconds after engine started, engine speed increases to 1200 rpm
 - ※ Others same as above ①.
- ③ When abnormal condition
 - a. The lamp lights up and the buzzer sounds.
 - b. If **BUZZER STOP** switch is pressed, buzzer sound is canceled but the lamp light up until normal condition.

3. CLUSTER CONNECTOR

No.	Signal	Input / Output
1	Power IG(24V)	Input(20~32V)
2	GND	Input(0V)
3	Serial-(RX)	Input(Vpp=12V)
4	Serial+(TX)	Output(Vpp=4V)

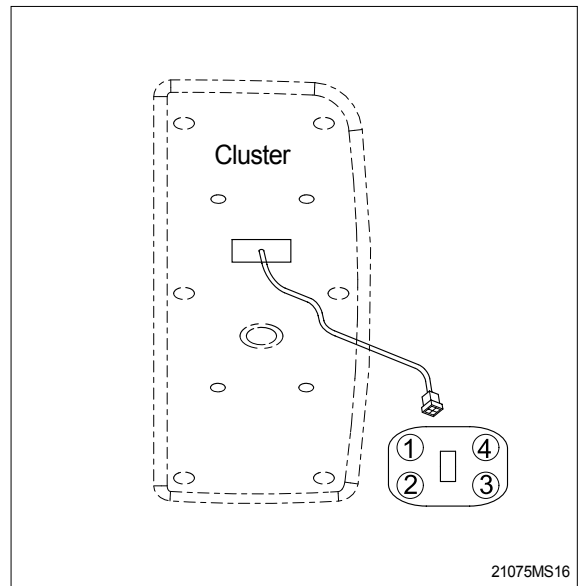

4. LCD main operation display

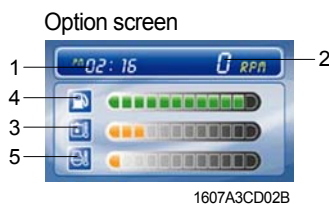
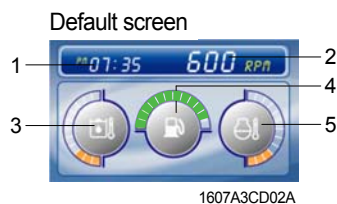

- 1 Time display
- 2 RPM display
- 3 Hydraulic oil temperature gauge
- 4 Fuel level gauge
- 5 Engine coolant temperature gauge

1) Time display



- ① This displays the current time.

※ Refer to the page 5-34 to set time for details.

2) RPM display



- ① This displays the engine rpm.

3) Hydraulic oil temperature gauge

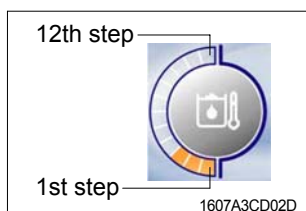

- ① This gauge indicates the temperature of hydraulic oil in 12 step gauge.

- 1st step : Below 30°C(86°F)
- 2nd~10th step : 30-105 °C(86-221°F)
- 11th~12th step : Above 105°C(221°F)

- ② The gauge between 2nd and 10th steps illuminates when operating.

- ③ Keep idling engine at low speed until the gauge between 2nd and 10th steps illuminates, before operation of machine.

- ④ When the gauge of 11th and 12th steps illuminates, reduce the load on the system. If the gauge stays in the 11th~12th steps, stop the machine and check the cause of the problem.

4) Fuel level gauge

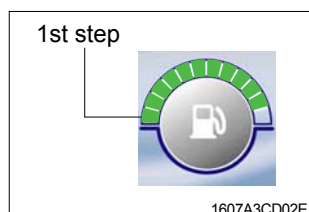

- ① This gauge indicates the amount of fuel in the fuel tank.

- ② Fill the fuel when the 1st step or fuel icon blinks in red.

※ If the gauge illuminates the 1st step or fuel icon blinks in red even though the machine is on the normal condition, check the electric device as that can be caused by the poor connection of electricity or sensor.

5) Engine coolant temperature gauge

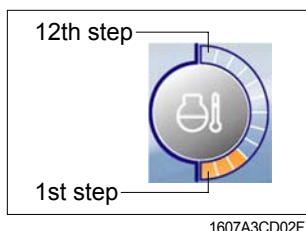

- ① This gauge indicates the temperature of coolant in 12 step gauge.

- 1st step : Below 30°C(86°F)
- 2nd~10th step : 30-105 °C(86-221°F)
- 11th~12th step : Above 105°C(221°F)

- ② The gauge between 2nd and 10th steps illuminates when operating.

- ③ Keep idling engine at low speed until the gauge between 2nd and 10th steps illuminates, before operation of machine.

- ④ When the gauge of 11th and 12th steps illuminates, turn OFF the engine, check the radiator and engine.

5. Warning of main operation screen

1) Warning display

(1) Engine coolant temperature



- This lamp blinks and the buzzer sounds when the temperature of coolant is over the normal temperature 105°C (221°F) .
- Check the cooling system when the lamp blinks.

(2) Fuel level



- This lamp blinks and the buzzer sounds when the level of fuel is below 28 l (7.4U.S. gal).
- Fill the fuel immediately when the lamp blinks.

(3) Hydraulic oil temperature



- This warning lamp operates and the buzzer sounds when the temperature of hydraulic oil is over 105 °C (221 °F) .
- Check the hydraulic oil level when the lamp blinks.
- Check for debris between oil cooler and radiator.

(4) All gauge



- This lamp blinks and the buzzer sounds when the all gauge is abnormal.
- Check the each system when the lamp blinks.

(5) Communication error



- Communication problem between MCU controller and cluster makes the lamp blinks and the buzzer sounds.
- Check if any fuse for MCU burnt off.
If not check the communication line between them.





2) Pop-up icon display

No	Switch	Selected mode	Display
1	Power mode switch	High power work mode	
		Standard power work mode	
		Light power work mode	

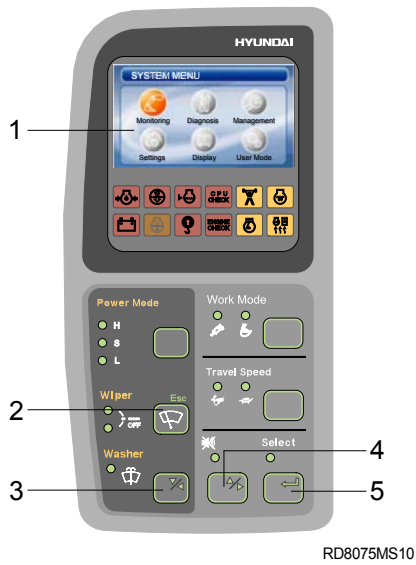
No	Switch	Selected mode	Display
2	Travel speed control switch	Low speed	
		High speed	







3) LCD

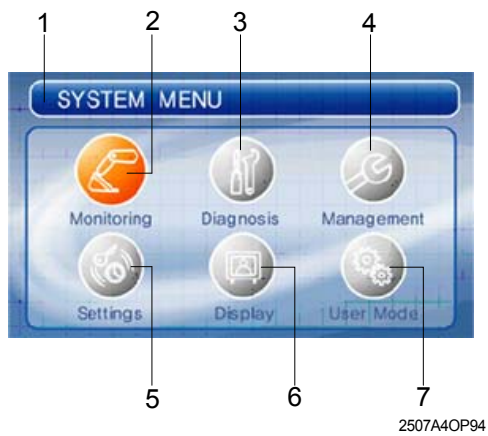

- 1  : LCD
- 2  : Esc
: Escape,
Return to the previous menu
- 3  : Down/Left Direction
- 4  : Up/Right Direction
- 5  : Select(Enter)
Activate the currently chosen item

(1) Main menu



- 1  : Menu information
- 2  : Monitoring
Equipment, Switch, Output
- 3  : Diagnosis
Current error, Recorded error
- 4  : Maintenance
- 5  : Settings
Time set, Dual mode
System lock(Reserved)
- 6  : Display
Operation skin, Brightness, Language
- 7  : User mode(null)

(2) Display map

① Monitoring

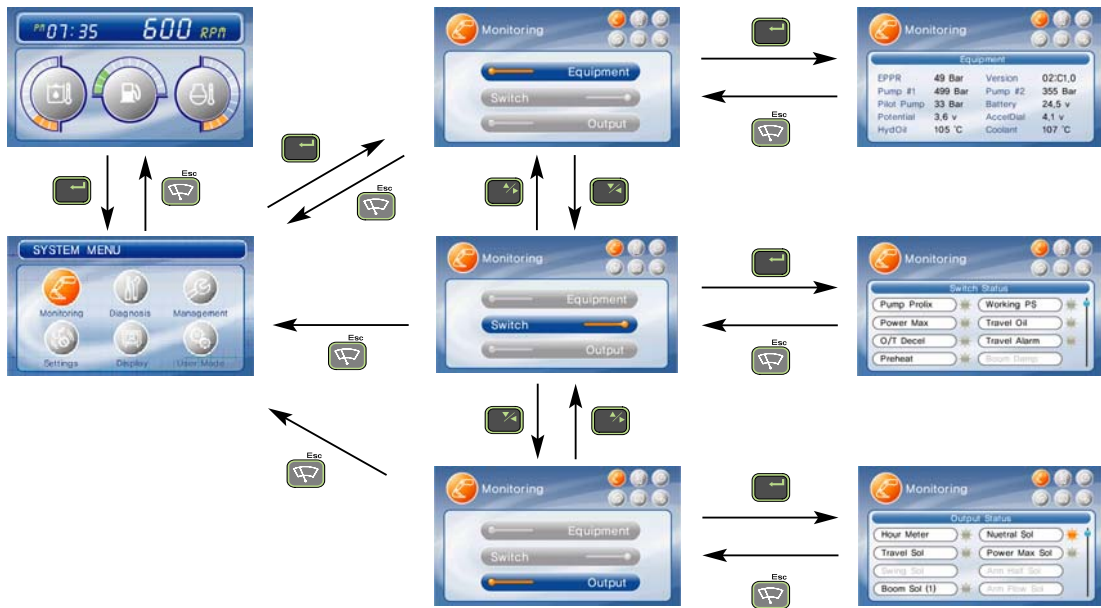

② Diagnosis

a. Protocol type 1

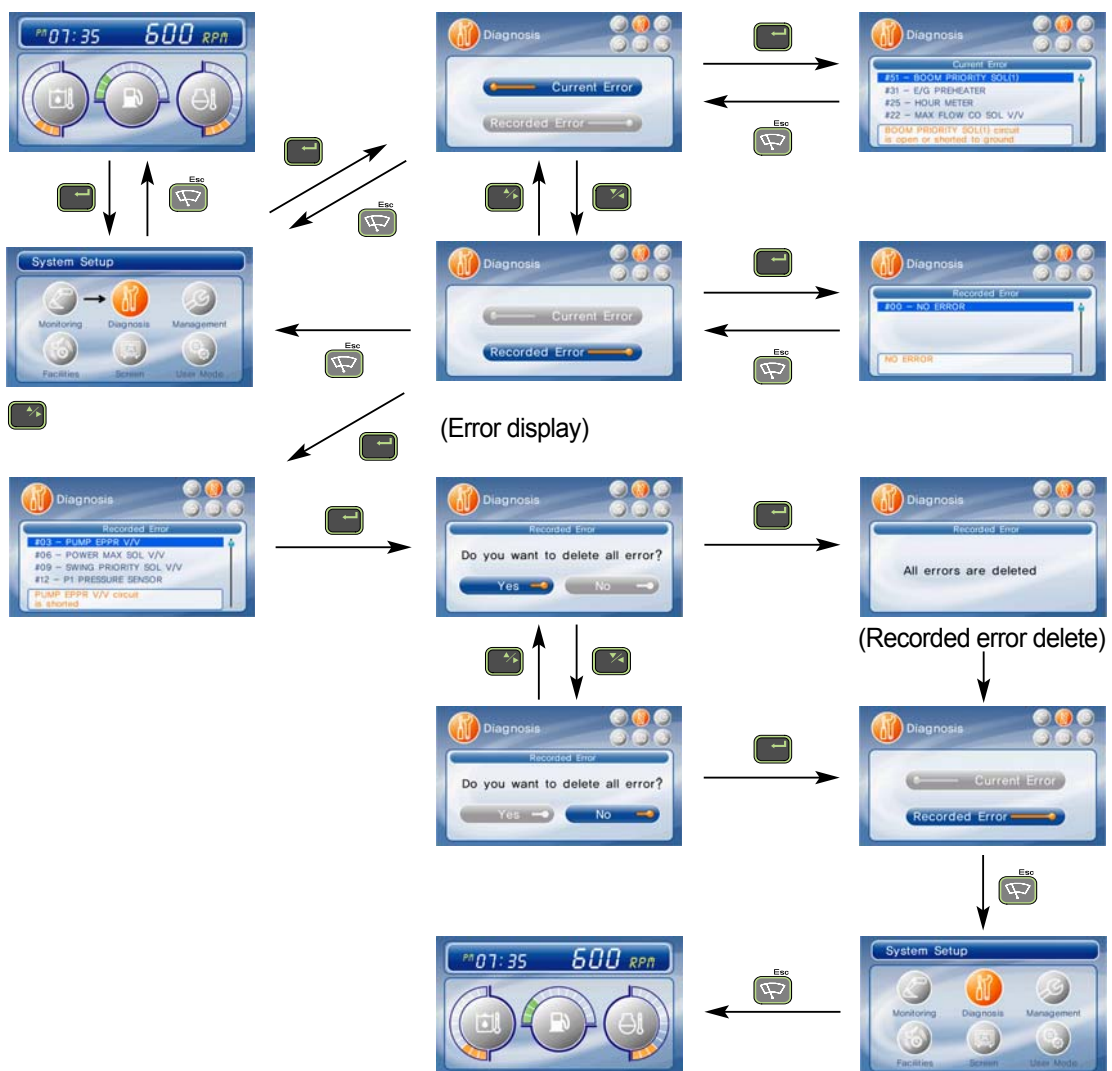

b. Protocol type 2

- If there are more than 2 error codes, each one can be displayed by pressing or switch respectively.
- 3 error codes (①SPN200200, ②FMI06, ③SPN6789, ④FMI04, ⑤345) display.

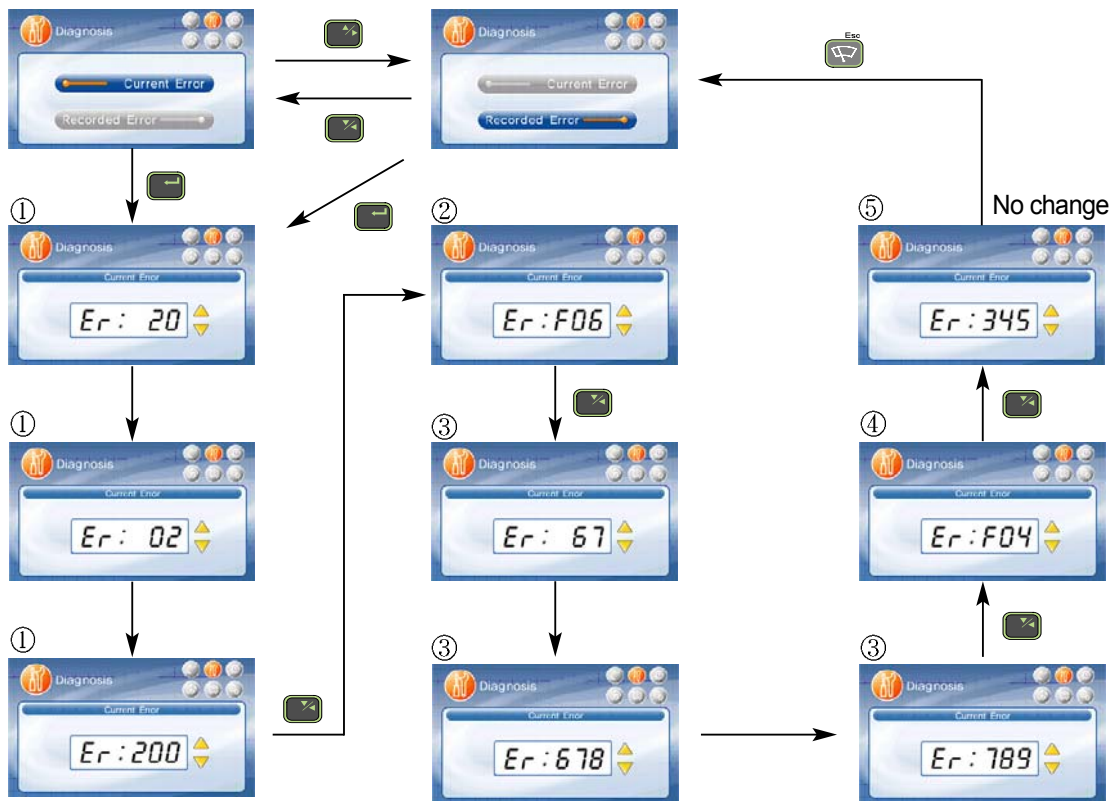

③ Maintenance

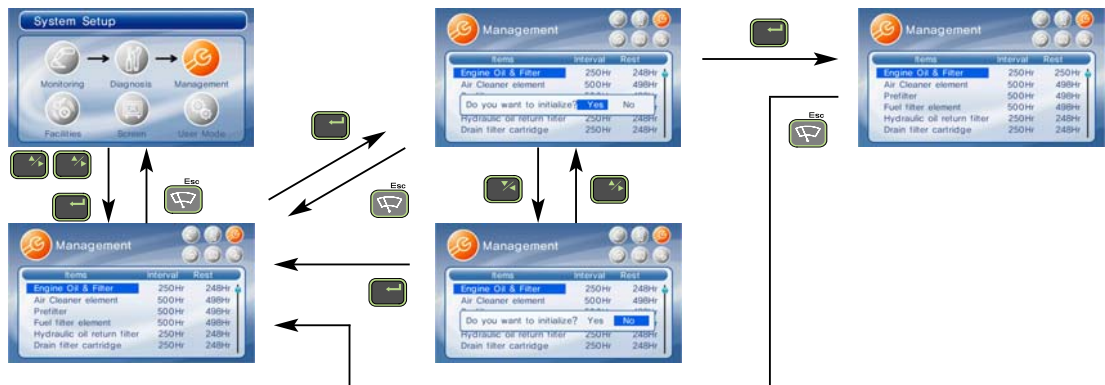

④ Setting

a. Time set



b. System lock - Reserved

c. Dual mode
- Changing the MCU mode



⑤ Display

a. Operation skin



b. Brightness

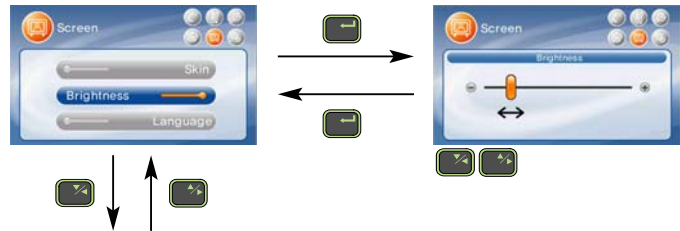

c. Language

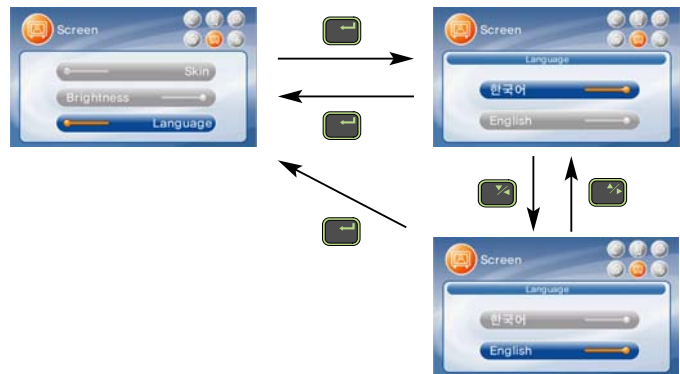

4) Warning and pilot lamp

(1) Engine oil pressure warning lamp

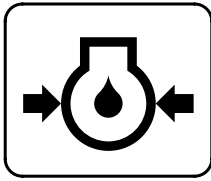

21073CD07

- ① This lamp blinks and the buzzer sounds after starting the engine because of the low oil pressure.
- ② If the lamp blinks during engine operation, shut OFF engine immediately. Check oil level.

(2) Air cleaner warning lamp

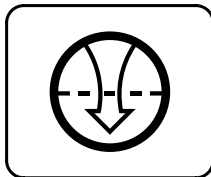

21073CD08

- ① This lamp blinks and the buzzer sounds when the filter of air cleaner is clogged.
- ② Check the filter and clean or replace it.

(3) MCU controller check warning lamp

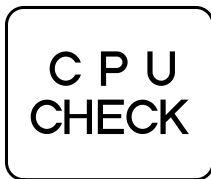

21073CD10

- ① If any fault code is received from MCU controller, this lamp blinks and the buzzer sounds.
- ② Check the communication line between MCU controller and cluster.

(4) Battery charging warning lamp

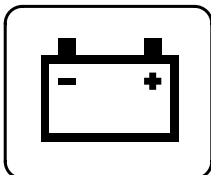

21073CD13

- ① This lamp blinks and the buzzer sounds when the starting switch is ON, it is turned OFF after starting the engine.
- ② Check the battery charging circuit when this lamp blinks during engine operation.

(5) Overload warning lamp

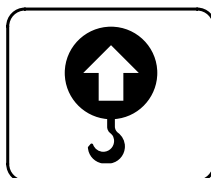

21073CD15

- ① When the machine is overload, the overload warning lamp blinks during the overload switch is ON.

(6) Decel pilot lamp

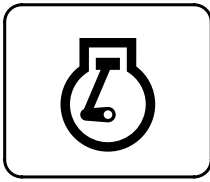

21073CD17

- ① Operating auto decel or one touch decel makes the lamp ON.
- ② The lamp will be ON when pushing one touch decel switch on the LH RCV lever.

(7) Warming up pilot lamp

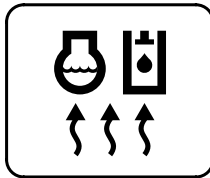

21073CD18

- ① This lamp is turned ON when the coolant temperature is below 30°C (86 °F).
- ② The automatic warming up is cancelled when the engine coolant temperature is above 30 °C, or when 10 minutes have passed since starting.

(8) Preheat pilot lamp

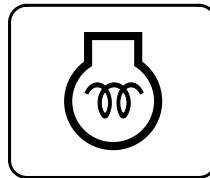

21073CD12

- ① Turning the start key switch ON position starts preheating in cold weather.
- ② Start the engine as this lamp is OFF.

5) SWITCH PANEL

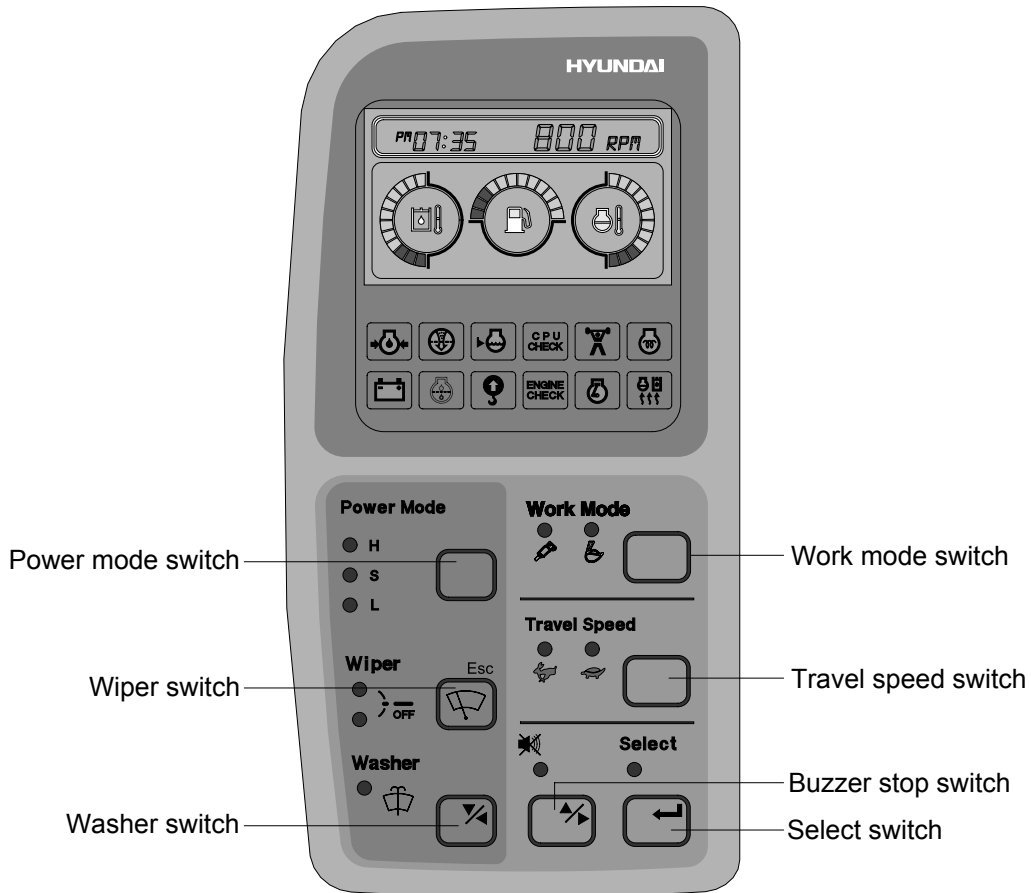

RD8075MS11

(1) Power mode switch

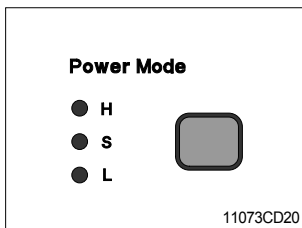

① This switch is to select the machine power mode, which shifts from high power work to standard power work and light power work in a row by pressing the switch.

- **H** : High power work mode
- **S** : Standard power work mode
- **L** : Light power work mode

(2) Wiper mode switch

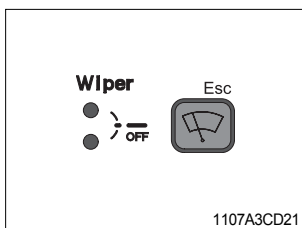

① This switch is used to operate wiper.

- Press the switch once to operate wiper.
- Press the switch once more to intermittently operate wiper low speed.
- Press the switch once more to turn off wiper.

- ※ **Wiper motor doesn't operate with front sliding door open.**
- ※ **If wiper does not operate with the start switch in the ON position, turn the switch off immediately. Check the cause. If the switch remains ON, it can result in motor failure.**

(3) Washer switch

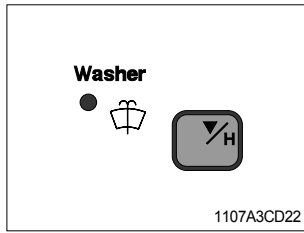

- ① The washer liquid is sprayed and the wiper is operated only while pressing this switch.
- ② The indicator lamp is turned ON when operating this switch.

(4) Travel speed control switch

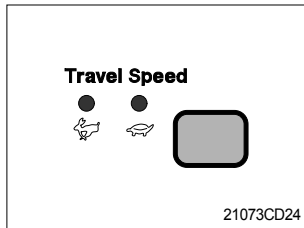

- ① This switch is to control the travel speed which is changed to high speed(Rabbit mark) by pressing the switch and low speed(Turtle mark) by pressing it again.

(5) Buzzer stop switch

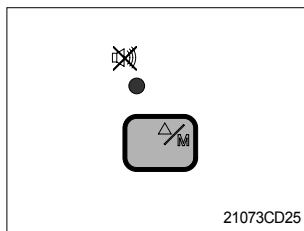

- ① When the starting switch is turned ON first, normally the alarm buzzer sounds for 2 seconds during lamp check operation.
- ② The red lamp lights ON and the buzzer sounds when the machine has a problem.
In this case, press this switch and buzzer stops, but the red lamp lights until the problem is cleared.

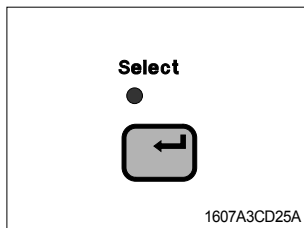

(6) Select switch

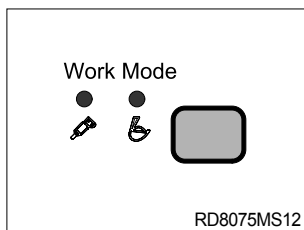

- ① This switch is used to enter main menu and sub menu for LCD.
※ **Refer to the page 5-32 for details.**

(7) Work mode switch



- ① This switch is to select the machine operation mode, which shifts from general operation mode to breaker mode by pressing the switch.
 -  : General work mode
 -  : Breaker operation mode