

SECTION 8 DISASSEMBLY AND ASSEMBLY

Group 1	Precaution	8-1
Group 2	Tightening Torque	8-4
Group 3	Pump Device	8-7
Group 4	Main Control Valve	8-29
Group 5	Swing Device	8-43
Group 6	Travel Device	8-65
Group 7	RCV Lever	8-103
Group 8	Turning Joint	8-118
Group 9	Boom, Arm and Bucket Cylinder	8-123
Group 10	Undercarriage	8-140
Group 11	Work Equipment	8-152

SECTION 8 DISASSEMBLY AND ASSEMBLY

GROUP 1 PRECAUTIONS

1. REMOVAL WORK

- 1) Lower the work equipment completely to the ground.
If the coolant contains antifreeze, dispose of it correctly.
- 2) After disconnecting hoses or tubes, cover them or fit blind plugs to prevent dirt or dust from entering.
- 3) When draining oil, prepare a container of adequate size to catch the oil.
- 4) Confirm the match marks showing the installation position, and make match marks in the necessary places before removal to prevent any mistake when assembling.
- 5) To prevent any excessive force from being applied to the wiring, always hold the connectors when disconnecting the connectors.
- 6) Fit wires and hoses with tags to show their installation position to prevent any mistake when installing.
- 7) Check the number and thickness of the shims, and keep in a safe place.
- 8) When raising components, be sure to use lifting equipment of ample strength.
- 9) When using forcing screws to remove any components, tighten the forcing screws alternately.
- 10) Before removing any unit, clean the surrounding area and fit a cover to prevent any dust or dirt from entering after removal.
- 11) When removing hydraulic equipment, first release the remaining pressure inside the hydraulic tank and the hydraulic piping.
- 12) If the part is not under hydraulic pressure, the following corks can be used.

Nominal number	Dimensions		
	D	d	L
06	6	5	8
08	8	6.5	11
10	10	8.5	12
12	12	10	15
14	14	11.5	18
16	16	13.5	20
18	18	15	22
20	20	17	25
22	22	18.5	28
24	24	20	30
27	27	22.5	34

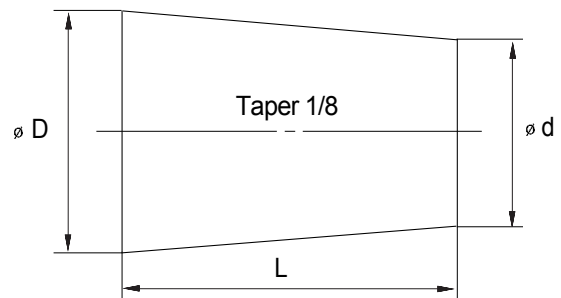

2. INSTALL WORK

- 1) Tighten all bolts and nuts(Sleeve nuts) to the specified torque.
- 2) Install the hoses without twisting or interference.
- 3) Replace all gaskets, O-rings, cotter pins, and lock plates with new parts.
- 4) Bend the cotter pin or lock plate securely.
- 5) When coating with adhesive, clean the part and remove all oil and grease, then coat the threaded portion with 2-3 drops of adhesive.
- 6) When coating with gasket sealant, clean the surface and remove all oil and grease, check that there is no dirt or damage, then coat uniformly with gasket sealant.
- 7) Clean all parts, and correct any damage, dents, burrs, or rust.
- 8) Coat rotating parts and sliding parts with engine oil.
- 9) When press fitting parts, coat the surface with antifriction compound(LM-P).
- 10)After installing snap rings, check that the snap ring is fitted securely in the ring groove(Check that the snap ring moves in the direction of rotation).
- 11)When connecting wiring connectors, clean the connector to remove all oil, dirt, or water, then connect securely.
- 12)When using eyebolts, check that there is no deformation or deterioration, and screw them in fully.
- 13)When tightening split flanges, tighten uniformly in turn to prevent excessive tightening on one side.
- 14)When operating the hydraulic cylinders for the first time after repairing and reassembling the hydraulic cylinders, pumps, or other hydraulic equipment or piping, always bleed the air from the hydraulic cylinders as follows:
 - (1) Start the engine and run at low idling.
 - (2) Operate the control lever and actuate the hydraulic cylinder 4-5 times, stopping 100mm before the end of the stroke.
 - (3) Next, operate the piston rod to the end of its stroke to relieve the circuit. (The air bleed valve is actuated to bleed the air.)
 - (4) After completing this operation, raise the engine speed to the normal operating condition.
 - ※ If the hydraulic cylinder has been replaced, carry out this procedure before assembling the rod to the work equipment.
 - ※ Carry out the same operation on machines that have been in storage for a long time after completion of repairs.

3. COMPLETING WORK

- 1) If the coolant has been drained, tighten the drain valve, and add water to the specified level. Run the engine to circulate the water through the system. Then check the water level again.
- 2) If the hydraulic equipment has been removed and installed again, add engine oil to the specified level. Run the engine to circulate the oil through the system. Then check the oil level again.
- 3) If the piping or hydraulic equipment, such as hydraulic cylinders, pumps, or motors, have been removed for repair, always bleed the air from the system after reassembling the parts.
- 4) Add the specified amount of grease(Molybdenum disulphied grease) to the work equipment related parts.

GROUP 2 TIGHTENING TORQUE

1. MAJOR COMPONENTS

No.	Descriptions	Bolt size	Torque		
			kgf · m	lbf · ft	
1	Engine	Engine mounting bolt(Engine-Bracket)	M12 × 1.75	10.0 ± 0.5	72.3 ± 3.6
2		Engine mounting bolt(Bracket-Frame, FR)	M16 × 2.0	55 ± 3.5	398 ± 25.3
3		Engine mounting bolt(Bracket-Frame, RR)	M20 × 2.5	30 ± 3.5	253 ± 25.3
4		Radiator mounting bolt, nut	M12 × 1.75	12.2 ± 1.3	88.2 ± 9.4
5		Coupling mounting bolt	M16 × 2.0	22.0 ± 1.0	159 ± 7.2
6	Hydraulic system	Main pump mounting bolt	M16 × 2.0	22.1 ± 2.4	159 ± 17.3
7		Main control valve mounting bolt	M12 × 1.75	12.2 ± 1.3	88.2 ± 9.4
8		Fuel tank mounting bolt	M20 × 2.5	45 ± 5.1	325 ± 36.9
9		Hydraulic oil tank mounting bolt	M20 × 2.5	45 ± 5.1	325 ± 36.9
10		Turning joint mounting bolt, nut	M12 × 1.75	12.3 ± 1.3	88.2 ± 9.4
11	Power train system	Swing motor mounting bolt	M16 × 2.0	29.6 ± 3.2	214 ± 23.1
12		Swing bearing upper mounting bolt	M18 × 2.0	41.3 ± 4.5	299 ± 32.5
13		Swing bearing lower mounting bolt	M16 × 2.0	29.7 ± 4.5	215 ± 32.5
14		Travel motor mounting bolt	M16 × 2.0	23 ± 2.5	166 ± 18.1
15		Sprocket mounting bolt	M16 × 2.0	29.7 ± 4.5	215 ± 32.5
16		Carrier roller mounting bolt, nut	M16 × 2.0	29.7 ± 4.5	215 ± 32.5
17	Under carriage	Track roller mounting bolt	M16 × 2.0	29.7 ± 4.5	215 ± 32.5
18		Track tension cylinder mounting bolt	M16 × 2.0	29.7 ± 4.5	215 ± 32.5
19		Track shoe mounting bolt, nut	M16 × 1.5	42 ± 4	304 ± 28.9
20		Track guard mounting bolt	M16 × 2.0	29.7 ± 4.5	215 ± 32.5
21	Others	Counter weight mounting bolt	M24 × 3.0	97.8 ± 10	707 ± 72.3
22		Cab mounting bolt, nut	M12 × 1.75	12.2 ± 1.3	88.2 ± 9.4
23		Operator's seat mounting bolt	M 8 × 1.25	1.17 ± 0.1	8.5 ± 0.7

※ For tightening torque of engine and hydraulic components, see each component disassembly and assembly.

2. TORQUE CHART

Use following table for unspecified torque.

1) BOLT AND NUT - Coarse thread

Bolt size	8T		10T	
	kgf · m	lbf · ft	kgf · m	lbf · ft
M 6 × 1.0	0.85 ~ 1.25	6.15 ~ 9.04	1.14 ~ 1.74	8.2 ~ 12.6
M 8 × 1.25	2.0 ~ 3.0	14.5 ~ 21.7	2.73 ~ 4.12	19.7 ~ 29.8
M10 × 1.5	4.0 ~ 6.0	28.9 ~ 43.4	5.5 ~ 8.3	39.8 ~ 60
M12 × 1.75	7.4 ~ 11.2	53.5 ~ 79.5	9.8 ~ 15.8	71 ~ 114
M14 × 2.0	12.2 ~ 16.6	88.2 ~ 120	16.7 ~ 22.5	121 ~ 167
M16 × 2.0	18.6 ~ 25.2	135 ~ 182	25.2 ~ 34.2	182 ~ 247
M18 × 2.5	25.8 ~ 35.0	187 ~ 253	35.1 ~ 47.5	254 ~ 343
M20 × 2.5	36.2 ~ 49.0	262 ~ 354	49.2 ~ 66.6	356 ~ 482
M22 × 2.5	48.3 ~ 63.3	350 ~ 457	65.8 ~ 98.0	476 ~ 709
M24 × 3.0	62.5 ~ 84.5	452 ~ 611	85.0 ~ 115	615 ~ 832
M30 × 3.5	124 ~ 168	898 ~ 1214	169 ~ 229	1223 ~ 1655
M36 × 4.0	174 ~ 236	1261 ~ 1703	250 ~ 310	1808 ~ 2242

2) BOLT AND NUT - Fine thread

Bolt size	8T		10T	
	kgf · m	lbf · ft	kgf · m	lbf · ft
M 8 × 1.0	2.17 ~ 3.37	15.7 ~ 24.3	3.04 ~ 4.44	22.0 ~ 32.0
M10 × 1.25	4.46 ~ 6.66	32.3 ~ 48.2	5.93 ~ 8.93	42.9 ~ 64.6
M12 × 1.25	7.78 ~ 11.58	76.3 ~ 83.7	10.6 ~ 16.0	76.6 ~ 115
M14 × 1.5	13.3 ~ 18.1	96.2 ~ 130	17.9 ~ 24.1	130 ~ 174
M16 × 1.5	19.9 ~ 26.9	144 ~ 194	26.6 ~ 36.0	193 ~ 260
M18 × 1.5	28.6 ~ 43.6	207 ~ 315	38.4 ~ 52.0	278 ~ 376
M20 × 1.5	40.0 ~ 54.0	289 ~ 390	53.4 ~ 72.2	386 ~ 522
M22 × 1.5	52.7 ~ 71.3	381 ~ 515	70.7 ~ 95.7	512 ~ 692
M24 × 2.0	67.9 ~ 91.9	491 ~ 664	90.9 ~ 123	658 ~ 890
M30 × 2.0	137 ~ 185	990 ~ 1338	182 ~ 248	1314 ~ 1795
M36 × 3.0	192 ~ 260	1389 ~ 1879	262 ~ 354	1893 ~ 2561

3) PIPE AND HOSE

Thread size	Width across flat(mm)	kgf · m	lbf · ft
1/4"	19	3	21.7
3/8"	22	4	28.9
1/2"	27	5	36.2
3/4"	36	12	86.8
1"	41	14	101

4) FITTING

Thread size	Width across flat(mm)	kgf · m	lbf · ft
1/4"	19	4	28.9
3/8"	22	5	36.2
1/2"	27	6	43.4
3/4"	36	13	94.0
1"	41	15	109

GROUP 3 PUMP DEVICE

1. REMOVAL AND INSTALL

1) REMOVAL

- (1) Lower the work equipment to the ground and stop the engine.
- (2) Operate the control levers and pedals several times to release the remaining pressure in the hydraulic piping
- (3) Loosen the breather slowly to release the pressure inside the hydraulic tank.

▲ Escaping fluid under pressure can penetrate the skin causing serious injury.

- (4) Loosen the drain plug under the hydraulic tank and drain the oil from the hydraulic tank.

· Hydraulic tank quantity : 100 l

- (5) Remove socket bolts(75) and disconnect pipe(74).

- (6) Disconnect pilot line hoses(11, 13, 14, 35, 37,47).

- (7) Remove socket bolts(67) and disconnect pump suction tube(5).

※ When pump suction tube is disconnected, the oil inside the piping will flow out, so catch it in oil pan.

- (8) Sling the pump assembly and remove the pump mounting bolts.

· Weight : 90kg(200lb)

※ Pull out the pump assembly from housing.
When removing the pump assembly, check that all the hoses have been disconnected.

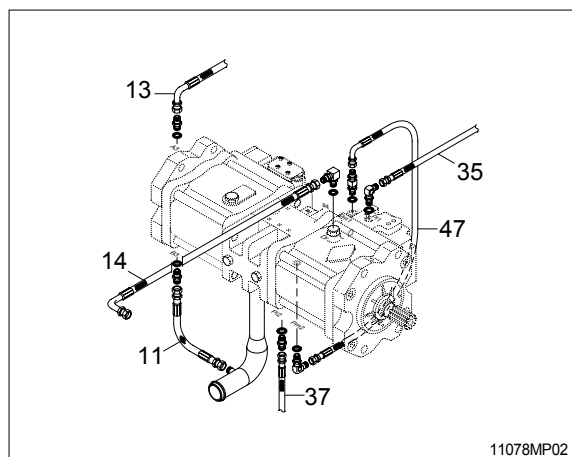
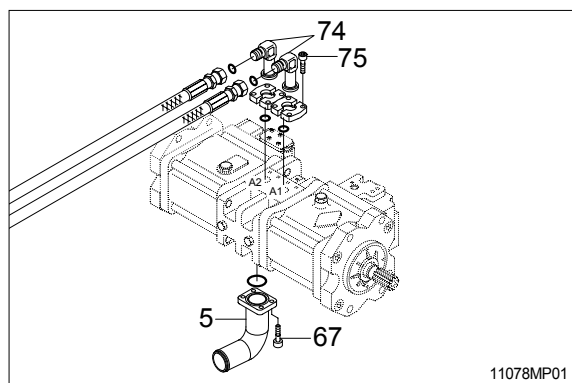

2) INSTALL

- (1) Carry out installation in the reverse order to removal.
- (2) Remove the suction strainer and clean it.
- (3) Replace return filter with new one.
- (4) Remove breather and clean it.
- (5) After adding oil to the hydraulic tank to the specified level.
- (6) Bleed the air from the hydraulic pump.
 - ① Remove the air vent plug(2EA).
 - ② Tighten plug lightly.
 - ③ Start the engine, run at low idling, and check oil come out from plug.
 - ④ Tighten plug.
- (7) Start the engine, run at low idling(3~5 minutes) to circulate the oil through the system.
- (8) Confirm the hydraulic oil level and check the hydraulic oil leak or not.

2. MAIN PUMP(1/2)

1) STRUCTURE

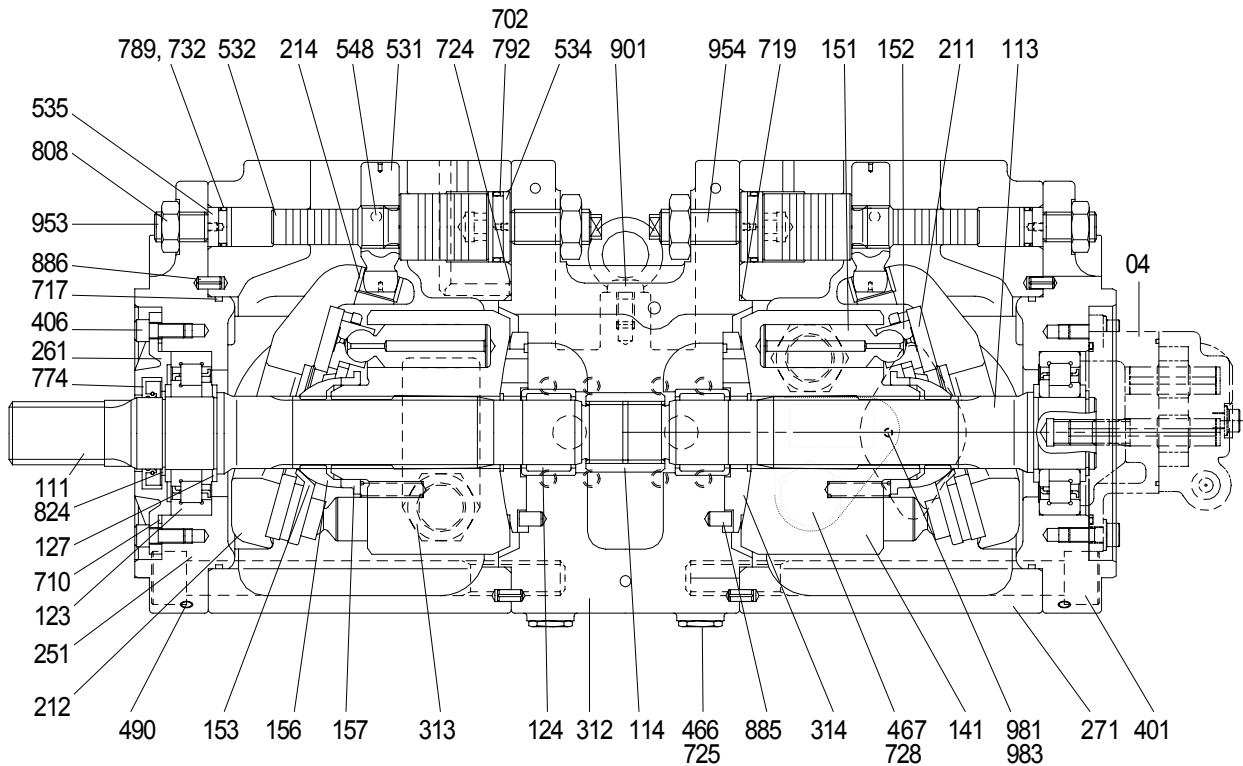

14072SF02

04	Gear pump	271	Pump casing	719	O-ring
111	Drive shaft(F)	312	Valve block	724	O-ring
113	Drive shaft(R)	313	Valve plate(R)	725	O-ring
114	Spline coupling	314	Valve plate(L)	728	O-ring
123	Roller bearing	401	Hexagon socket bolt	732	O-ring
124	Needle bearing	406	Hexagon socket bolt	774	Oil seal
127	Bearing spacer	466	VP Plug	789	Back up ring
141	Cylinder block	467	VP Plug	792	Back up ring
151	Piston	490	Plug	808	Hexagon head nut
152	Shoe	531	tilting pin	824	Snap ring
153	Set plate	532	Servo piston	885	Pin
156	Bushing	534	Stopper(L)	886	Spring pin
157	Cylinder spring	535	Stopper(S)	901	Eye bolt
211	Shoe plate	548	Pin	953	Set screw
212	Swash plate	702	O-ring	954	Set screw
214	Bushing	710	O-ring	981	Plate
251	Support	717	O-ring	983	Pin
261	Seal cover(F)				

2) TOOLS AND TIGHTENING TORQUE

(1) Tools

The tools necessary to disassemble/reassemble the pump are shown in the follow list.

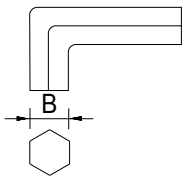
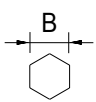
Tool name & size		Part name			
Name	B	Hexagon socket head bolt	PT plug (PT thread)	PO plug (PF thread)	Hexagon socket head setscrew
Allen wrench 	4	M 5	BP-1/16	-	M 8
	5	M 6	BP-1/8	-	M10
	6	M 8	BP-1/4	PO-1/4	M12, M14
	8	M10	BP-3/8	PO-3/8	M16, M18
	17	M20, M22	BP-1	PO-1, 1 1/4, 1 1/2	-
Double ring spanner, socket wrench, double(Single) open end spanner 	-	Hexagon socket head bolt	Hexagon nut	VP plug (PF thread)	
	19	M12	M12	VP-1/4	
	24	M16	M16	-	
	27	M18	M18	VP-1/2	
	30	M20	M20	-	
	36	-	-	VP-3/4	
Adjustable angle wrench		Medium size, 1 set			
Screw driver		Minus type screw driver, Medium size, 2 sets			
Hammer		Plastic hammer, 1 set			
Pliers		For snap ring, TSR-160			
Steel bar		Steel bar of key material approx. 10×8×200			
Torque wrench		Capable of tightening with the specified torques			

(2) Tightening torque

Part name	Bolt size	Torque		Wrench size	
		kgf · m	lbf · ft	in	mm
Hexagon socket head bolt Material : SCM435)	M 5	0.7	5.1	0.16	4
	M 6	1.2	8.7	0.20	5
	M 8	3.0	21.7	0.24	6
	M10	5.8	42.0	0.31	8
	M12	10.0	72.3	0.39	10
	M14	16.0	116	0.47	12
	M16	24.0	174	0.55	14
	M18	34.0	246	0.55	14
	M20	44.0	318	0.67	17
PT Plug(Materal : S45C) ※Wind a seal tape 1 1/2 to 2 turns round the plug	PT1/16	0.7	5.1	0.16	4
	PT 1/8	1.05	7.59	0.20	5
	PT 1/4	1.75	12.7	0.24	6
	PT 3/8	3.5	25.3	0.31	8
	PT 1/2	5.0	36.2	0.39	10
PF Plug(Materal : S45C)	PF 1/4	3.0	21.7	0.24	6
	PF 1/2	10.0	72.3	0.39	10
	PF 3/4	15.0	109	0.55	14
	PF 1	19.0	137	0.67	17
	PF 1 1/4	27.0	195	0.67	17
	PF 1 1/2	28.0	203	0.67	17

3) DISASSEMBLY

- (1) Select place suitable to disassembling.
 - ※ Select clean place.
 - ※ Spread rubber sheet, cloth or so on on overhaul workbench top to prevent parts from being damaged.
- (2) Remove dust, rust, etc, from pump surfaces with cleaning oil or so on.
- (3) Remove drain port plug(468) and let oil out of pump casing(Front and rear pump).
- (4) Remove hexagon socket head bolts(412, 413) and remove regulator.

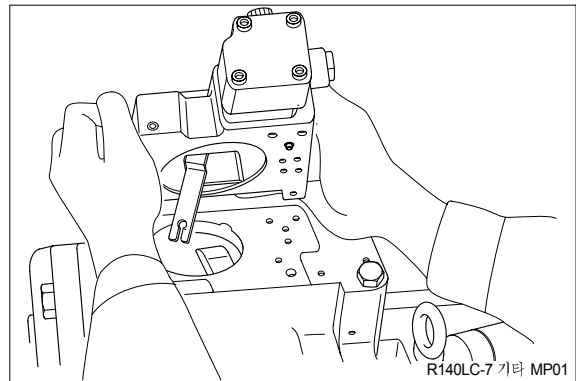

- (5) Loosen hexagon socket head bolts(401) which tighten swash plate support(251), pump casing(271) and valve block(312).
 - ※ If gear pump and so on are fitted to rear face of pump, remove them before starting this work.

- (6) Place pump horizontally on workbench with its regulator-fitting surface down and separate pump casing(271) from valve block(312).
 - ※ Before bringing this surface down, spread rubber sheet on workbench without fail to prevent this surface from being damaged.

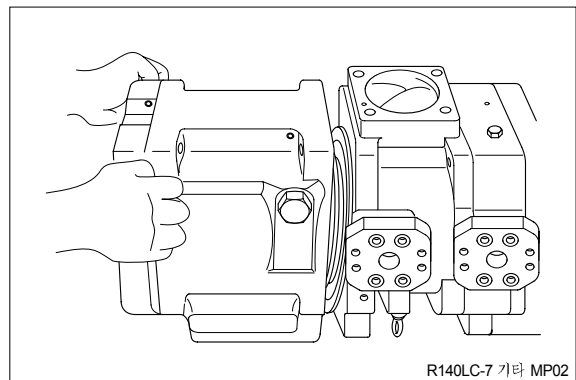

(7) Pull cylinder block(141) out of pump casing(271) straightly over drive shaft(111). Pull out also pistons(151), set plate(153), spherical bush(156) and cylinder springs(157) simultaneously.

※ Take care not to damage sliding surfaces of cylinder, spherical bushing, shoes, swash plate, etc.

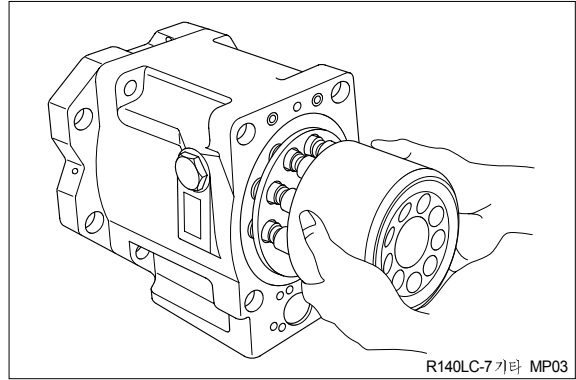

(8) Remove hexagon socket head bolts(406) and then seal cover(F, 261).

※ Fit bolt into pulling out tapped hole of seal cover(F), and cover can be removed easily.

※ Since oil seal is fitted on seal cover(F), take care not to damage it in removing cover.

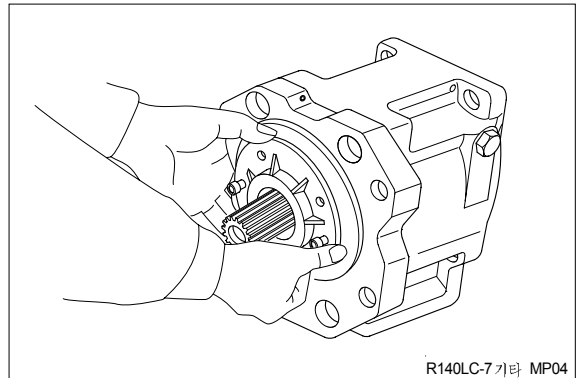

(9) Remove hexagon socket head bolts(408) and then seal cover(R, 262).

In case fitting a gear pump, first, remove gear pump.

(10) Tapping lightly fitting flange section of swash plate support(251) on its pump casing side, separate swash plate support from pump casing.

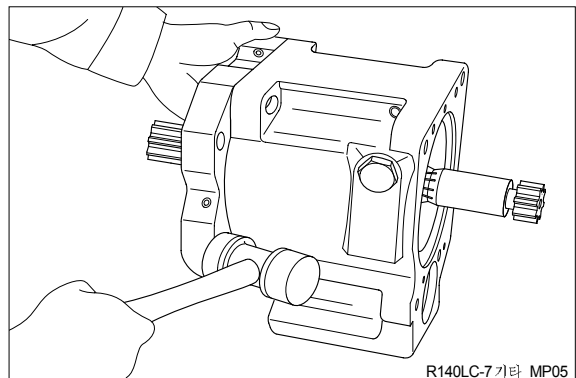

(11) Remove shoe plate(211) and swash plate(212) from pump casing(271).

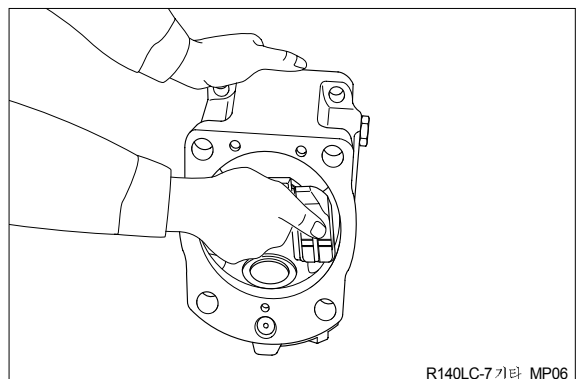

- (12) Tapping lightly shaft ends of drive shafts (111, 113) with plastic hammer, take out drive shafts from swash plate supports.

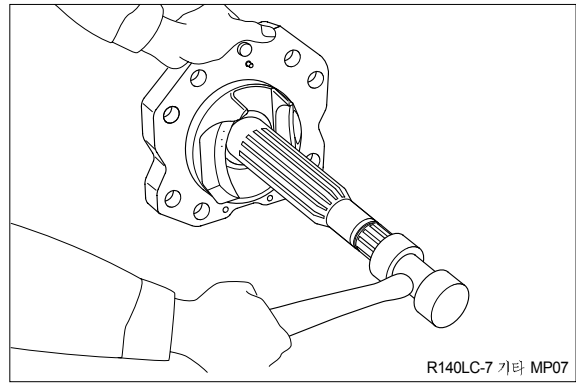

- (13) Remove valve plates(313, 314) from valve block(312).

※ These may be removed in work(6).

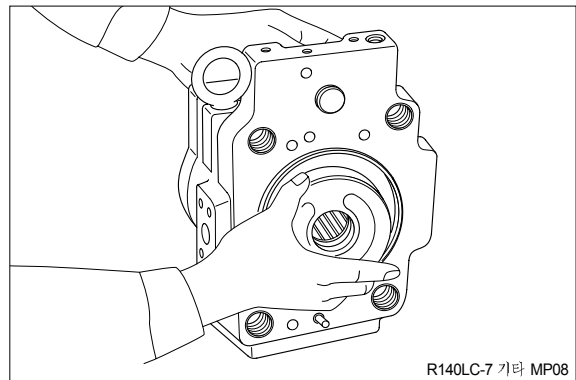

- (14) If necessary, remove stopper(L, 534), stopper(S, 535), servo piston(532) and tilting pin(531) from pump casing(271), and needle bearing(124) and splined coupling(114) from valve block(312).

- ※ In removing tilting pin, use a protector to prevent pin head from being damaged.
- ※ Since loctite is applied to fitting areas of tilting pin and servo piston, take care not to damage servo piston.
- ※ Do not remove needle bearing as far as possible, except when it is considered to be out of its life span.
- ※ Do not loosen hexagon nuts of valve block and swash plate support.
If loosened, flow setting will be changed.

4) ASSEMBLY

(1) For reassembling reverse the disassembling procedures, paying attention to the following items.

- ① Do not fail to repair the parts damaged during disassembling, and prepare replacement parts in advance.
- ② Clean each part fully with cleaning oil and dry it with compressed air.
- ③ Do not fail to apply clean working oil to sliding sections, bearings, etc. before assembling them.
- ④ In principle, replace seal parts, such as O-rings, oil seals, etc.
- ⑤ For fitting bolts, plug, etc., prepare a torque wrench or so on, and tighten them with torques shown in page 8-11, 12.
- ⑥ For the double-pump, take care not to mix up parts of the front pump with those of the rear pump.

(2) Fit swash plate support(251) to pump casing(271), tapping the former lightly with a hammer.

- ※ After servo piston, tilting pin, stopper(L) and stopper(S) are removed, fit them soon to pump casing in advance for reassembling.
- ※ In tightening servo piston and tilting pin, use a protector to prevent tilting pin head and feedback pin from being damaged. In addition, apply loctite(Medium strength) to their threaded sections.

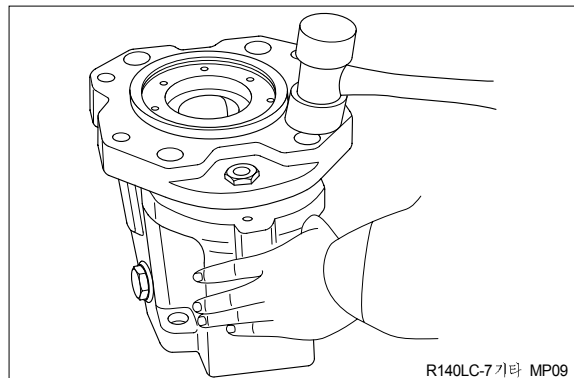

- (3) Place pump casing with its regulator fitting surface down, fit tilting bush of swash plate to tilting pin(531) and fit swash plate (212) to swash plate support(251) correctly. Confirm with fingers of both hands that
- ※ swash plate can be removed smoothly.
- Apply grease to sliding sections of swash plate and swash plate support, and drive shaft can be fitted easily.

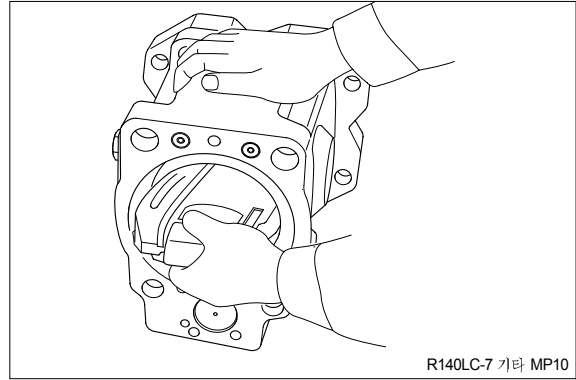

- (4) To swash plate support(251), fit drive shaft(111) set with bearing(123), bearing spacer(127) and snap ring(824).
- ※ Do not tap drive shaft with hammer or so on.
 - ※ Assemble them into support, tapping outer race of bearing lightly with plastic hammer.
- Fit them fully, using steel bar or so on.

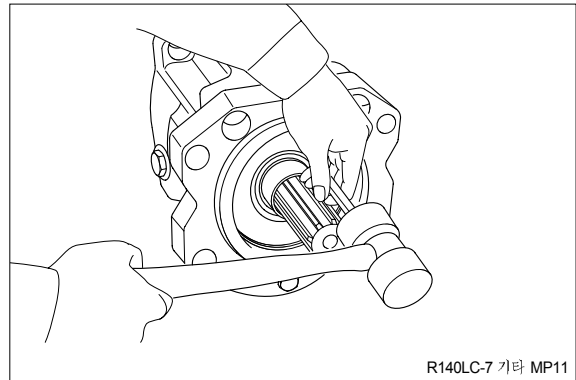

- (5) Assemble seal cover(F, 261) to pump casing(271) and fix it with hexagon socket head bolts(406).
- ※ Apply grease lightly to oil seal in seal cover(F).
 - ※ Assemble oil seal, taking full care not to damage it.
- For tandem type pump, fit rear cover(263) and seal cover(262) similarly.

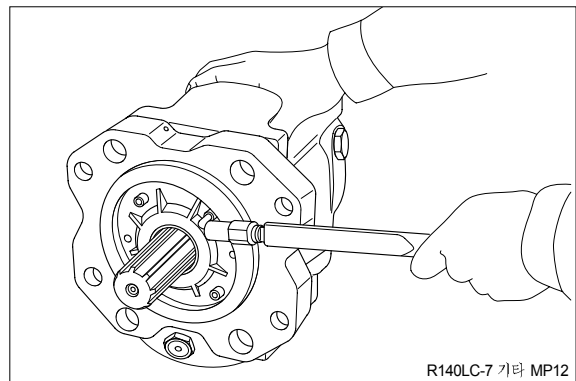

- (6) Assemble piston cylinder subassembly [cylinder block(141), piston subassembly (151, 152), set plate(153), spherical bush (156), spacer(158) and cylinder spring (157)].
- Fit spline phases of retainer and cylinder. Then, insert piston cylinder subassembly into pump casing.

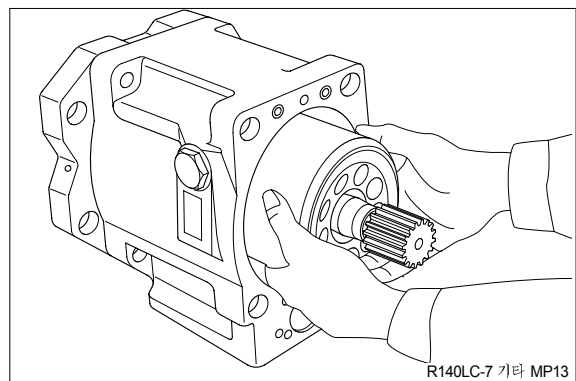

(7) Fit valve plate(313) to valve block(312), entering pin into pin hole.

- ※ Take care not to mistake suction / delivery directions of valve plate.

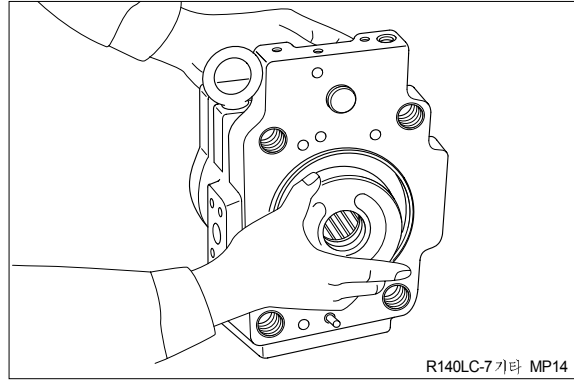

(8) Fit valve block(312) to pump casing(271) and tighten hexagon socket head bolts (401).

- ※ At first assemble this at rear pump side, and this work will be easy.
- ※ Take care not to mistake direction of valve block.
- ※ Clockwise rotation(Viewed from input shaft side) - Fit block with regulator up and with delivery flange left, viewed from front side.
- ※ Counter clockwise rotation(Viewed from input shaft side) - Fit block with delivery flange right, viewed from front side.

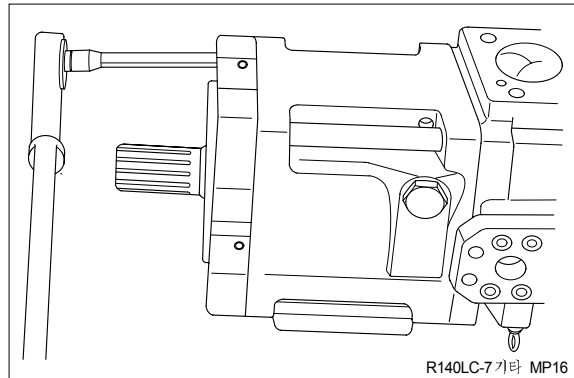

(9) Putting feedback pin of tilting pin into feedback lever of regulator, fit regulator and tighten hexagon socket head bolts (412, 413).

- ※ Take care not to mistake regulator of front pump for that of rear pump.

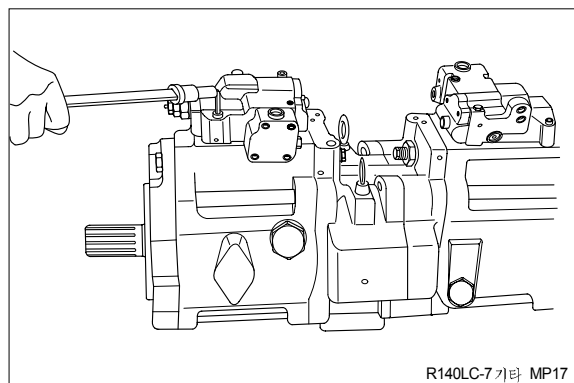

(10) Fit drain port plug(468).

This is the end of reassembling procedures.

3. REGULATOR

1) STRUCTURE(1/2)

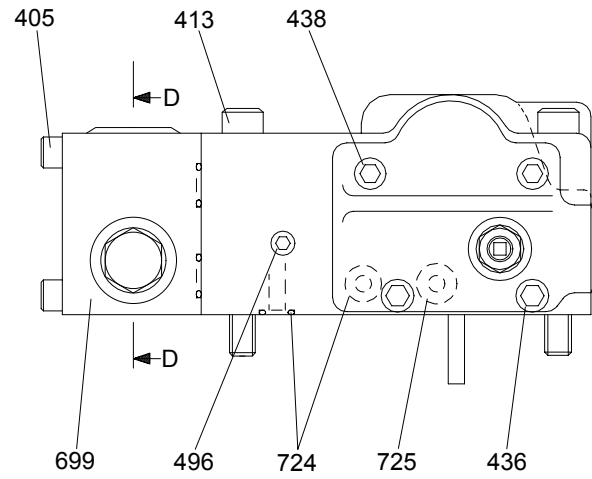
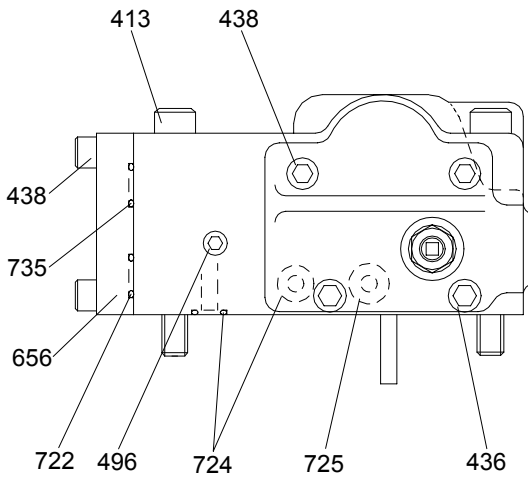
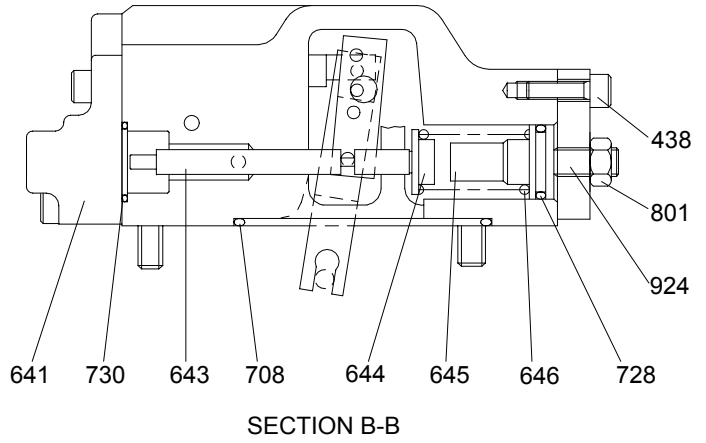
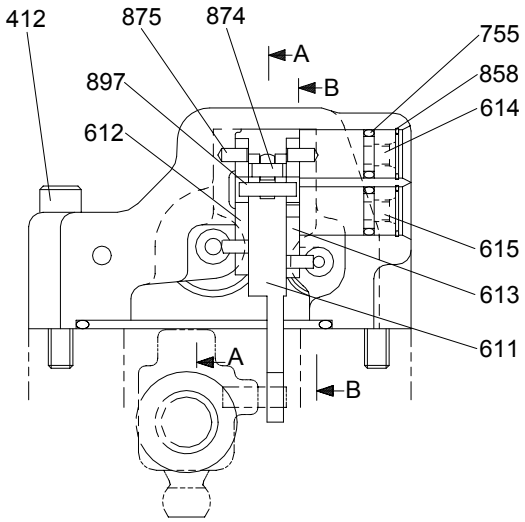

VIEW C(FRONT)

VIEW C(REAR)

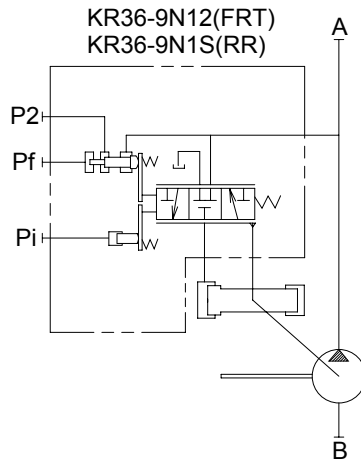
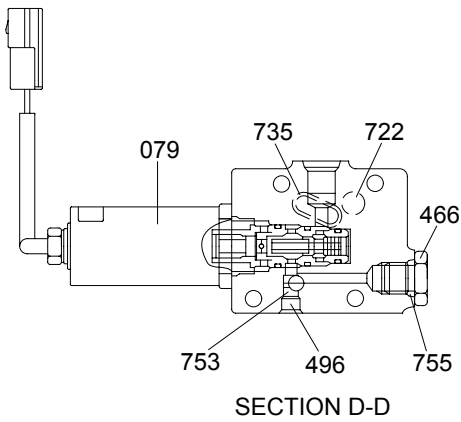

REGULATOR(2/2)

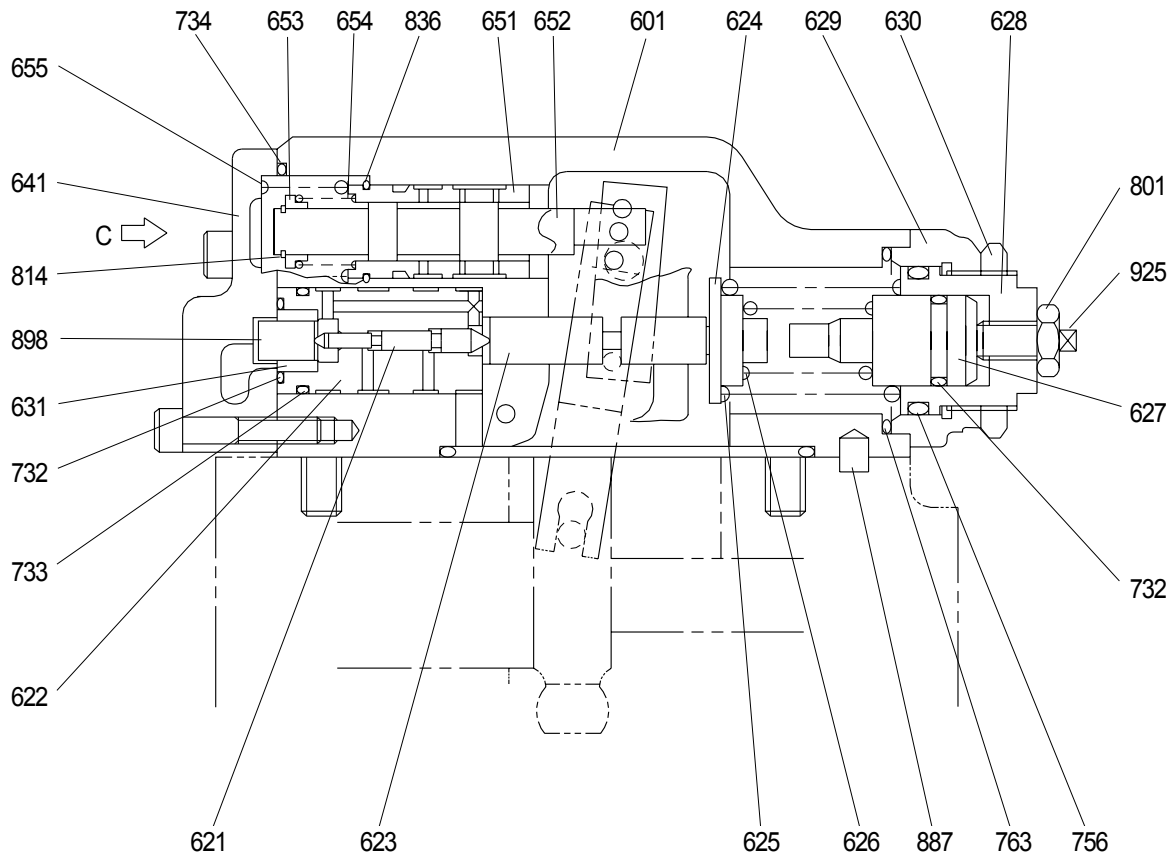

SECTION A-A



R140LC-7 기타 2-5

405 Hexagon socket screw	629 Cover(C)	730 O-ring
412 Hexagon socket screw	630 Lock nut	732 O-ring
413 Hexagon socket screw	631 Sleeve, pf	733 O-ring
436 Hexagon socket screw	641 Pilot cover	734 O-ring
438 Hexagon socket screw	643 Pilot piston	735 O-ring
466 Plug	644 Spring seat(Q)	753 O-ring
496 Plug	645 Adjust stem(Q)	755 O-ring
601 Casing	646 Pilot spring	756 O-ring
611 Feed back lever	651 Sleeve	763 O-ring
612 Lever(1)	652 Spool	801 Nut
613 Lever(2)	653 Spring seat	814 Snap ring
614 Fulcrum plug	654 Return spring	836 Snap ring
615 Adjust plug	655 Set spring	858 Snap ring
621 Compensator piston	656 Block cover	874 Pin
622 Piston case	699 Valve casing	875 Pin
623 Compensator rod	708 O-ring	887 Pin
624 Spring seat(C)	722 O-ring	897 Pin
625 Outer spring	724 O-ring	898 Pin
626 Inner spring	725 O-ring	924 Set screw
627 Adjust stem(C)	728 O-ring	925 Adjust screw(QI)
628 Adjust screw(C)		

2) TOOLS AND TIGHTENING TORQUE

(1) Tools

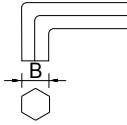
The tools necessary to disassemble/reassemble the pump are shown in the follow list.

Tool name & size		Part name			
Name	B	Hexagon socket head bolt	PT plug (PT thread)	PO plug (PF thread)	Hexagon socket head setscrew
Allen wrench 	4	M 5	BP-1/16	-	M 8
	5	M 6	BP-1/8	-	M10
	6	M 8	BP-1/4	PO-1/4	M12, M14
Double ring spanner, socket wrench, double(Single) open end spanner 	-	Hexagon head bolt	Hexagon nut	VP plug (PF thread)	
	6	M 8	M 8	-	
Adjustable angle wrench		Small size, Max 36mm			
Screw driver		Minus type screw driver, Medium size, 2 sets			
Hammer		Plastic hammer, 1 set			
Pliers		For snap ring, TSR-160			
Steel bar		4 × 100mm			
Torque wrench		Capable of tightening with the specified torques			
Pincers		-			
Bolt		M4, Length : 50mm			

(2) Tightening torque

Part name	Bolt size	Torque		Wrench size	
		kgf · m	lbf · ft	in	mm
Hexagon socket head bolt Material : SCM435)	M 5	0.7	5.1	0.16	4
	M 6	1.2	8.7	0.20	5
	M 8	3.0	21.7	0.24	6
	M10	5.8	42.0	0.31	8
	M12	10.0	72.3	0.39	10
	M14	16.0	116	0.47	12
	M16	24.0	174	0.55	14
	M18	34.0	246	0.55	14
	M20	44.0	318	0.67	17
PT Plut(Material : S45C) ※Wind a seal tape 1 1/2 to 2 turns round the plug	PT1/16	0.7	5.1	0.16	4
	PT 1/8	1.05	7.59	0.20	5
	PT 1/4	1.75	12.7	0.24	6
	PT 3/8	3.5	25.3	0.31	8
	PT 1/2	5.0	36.2	0.39	10
PF Plut(Material : S35C)	PF 1/4	3.0	21.7	0.24	6
	PF 1/2	10.0	72.3	0.39	10
	PF 3/4	15.0	109	0.55	14
	PF 1	19.0	137	0.67	17
	PF 1 1/4	27.0	195	0.67	17
	PF 1 1/2	28.0	203	0.67	17

3) DISASSEMBLY

Since the regulator consists of small precision finished parts, disassembly and assembly are rather complicated.

For this reason, replacement of a regulator assembly is recommended, unless there is a special reason, but in case disassembly is necessary for an unavoidable reason, read through this manual to the end before starting disassembly.

(1) Choose a place for disassembly.

- ※ Choose a clean place.
- ※ Spread rubber sheet, cloth, or so on top of work-bench to prevent parts from being damaged.

(2) Remove dust, rust, etc. from surfaces of regulator with clean oil.

(3) Remove hexagon socket head screw (412, 413) and remove regulator main body from pump main body.

- ※ Take care not to lose O-ring.

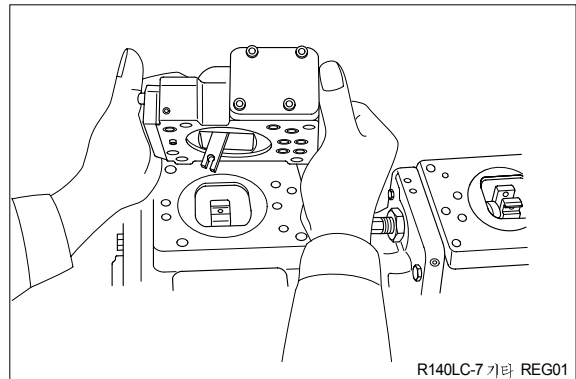

(4) Remove hexagon socket head screw (438) and remove cover(C,629)

- ※ Cover(C) is fitted with adjusting screw (C,QI) (628, 925), adjusting ring(C, 627), lock nut(630), hexagon nut(801) and adjusting screw(924).

Do not loosen these screws and nuts.

If they are loosened, adjusted pressure-flow setting will vary.

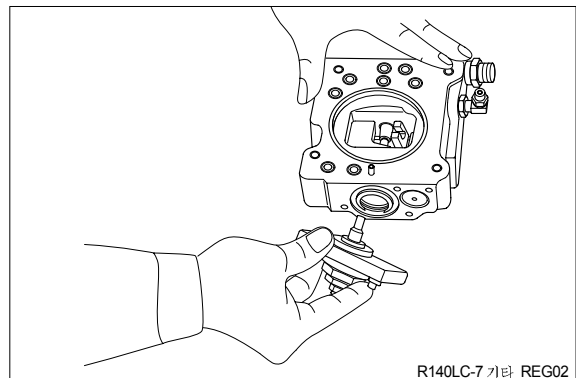

- (5) After removing cover(C, 629) subassembly, take out outer spring(625), inner spring (626) and spring seat(C, 624) from compensating section.

Then draw out adjusting ring(Q, 645), pilot spring(646) and spring seat(644) from pilot section.

- ※ Adjusting ring(Q,645) can easily be drawn out with M4 bolt.

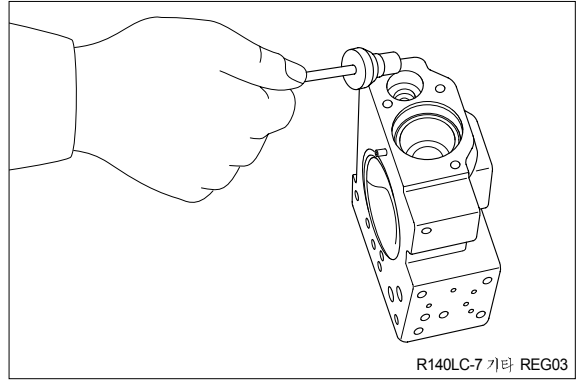

- (6) Remove hexagon socket head screws (436, 438) and remove pilot cover(641).

After removing pilot cover, take out set spring(655) from pilot section.

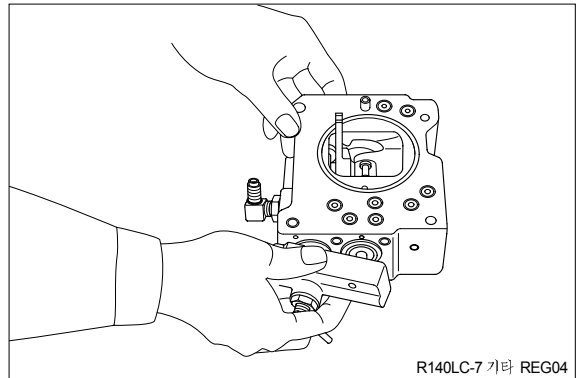

- (7) Remove snap ring(814) and take out spring seat(653), return spring(654) and sleeve(651).

- ※ Sleeve(651) is fitted with snap ring(836).
- ※ When removing snap ring(814), return spring(654) may pop out. Take care not to lose it.

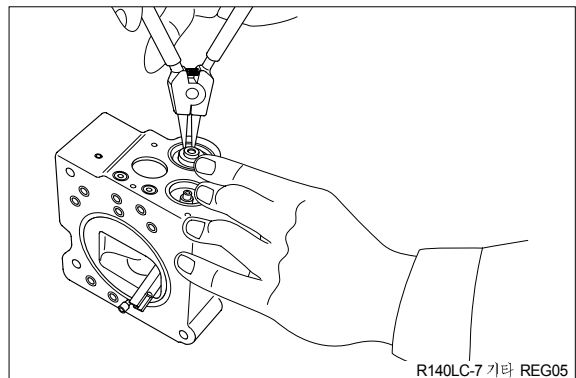

- (8) Remove locking ring(858) and take out fulcrum plug(614) and adjusting plug (615).

- ※ Fulcrum plug(614) and adjusting plug (615) can easily be taken out with M6 bolt.

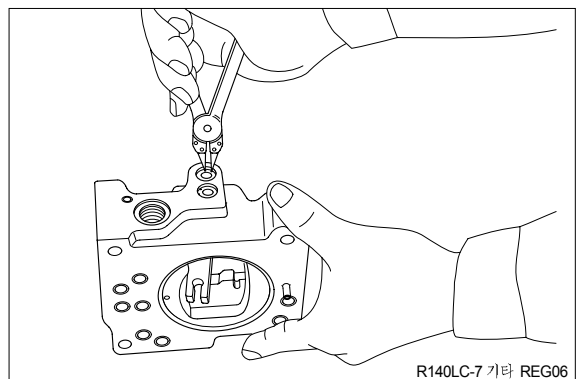

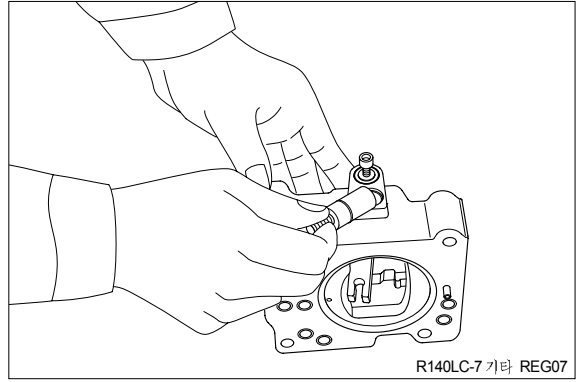

- (9) Remove lever(2, 613). Do not draw out pin(875).
※ Work will be promoted by using pincers or so on.

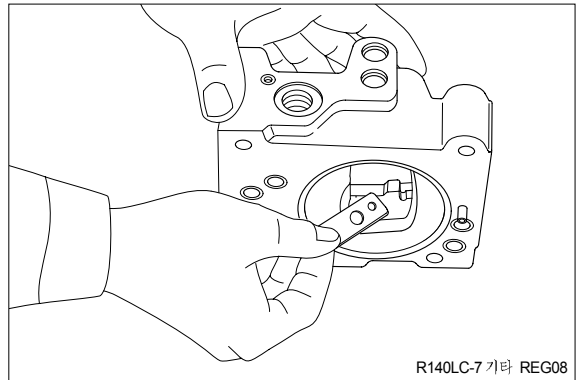

- (10) Draw out pin(874) and remove feedback lever(611).
Push out pin(874, 4mm in dia.) from above with slender steel bar so that it may not interfere with lever(1, 612).

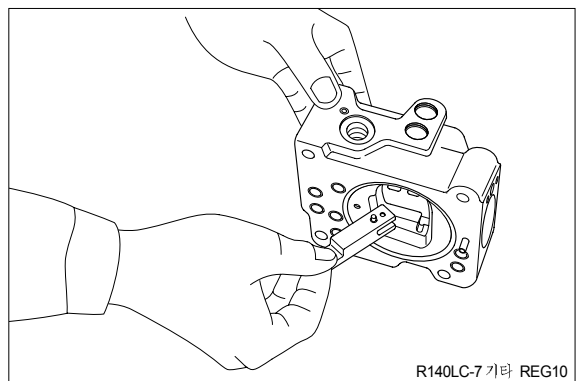
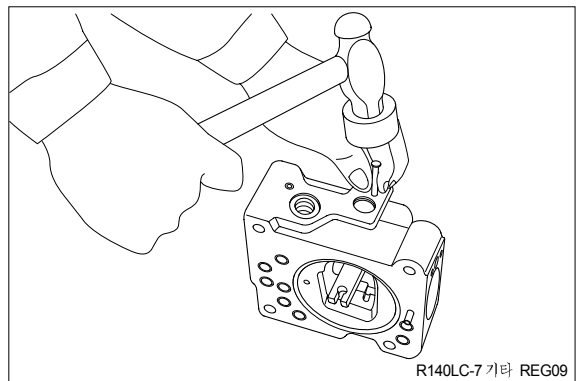

(11) Remove lever(1, 612). Do not draw out pin(875).

(12) Draw out pilot piston(643) and spool(652).

(13) Draw out piston case(622), compensating piston(621) and compensating rod(623).

※ Piston case(622) can be taken out by pushing compensating rod(623) at opposite side of piston case.

This completes disassembly.

4) ASSEMBLY

(1) For assembly, reverse disassembly procedures, but pay attention to the following items.

- ① Always repair parts that were scored at disassembly.
- ② Get replacement parts ready beforehand.
Mixing of foreign matter will cause malfunction.
Therefore, wash parts well with cleaning oil, let them dry with jet air and handle them in clean place.
- ③ Always tighten bolts, plugs, etc. to their specified torques.
- ④ Do not fail to coat sliding surfaces with clean hydraulic oil before assembly.
- ⑤ Replace seals such as O-ring with new ones as a rule.

(2) Put compensating rod(623) into compensating hole of casing(601).

(3) Put pin force-fitted in lever(1, 612) into groove of compensating rod and fit lever (1) to pin force-fitted in casing.

(4) Fit spool(652) and sleeve(651) into hole in spool of casing.

- ※ Confirm that spool and sleeve slide smoothly in casing without binding.
- ※ Pay attention to orientation of spool.

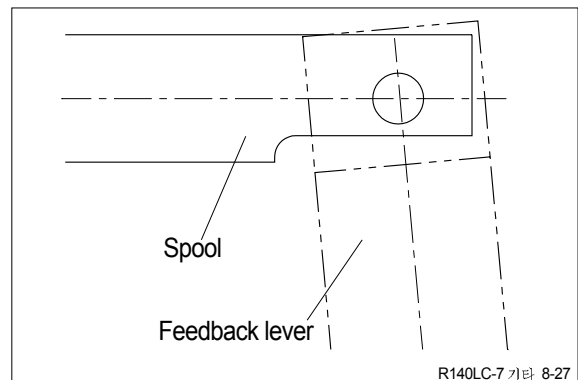

- (5) Fit feedback lever(611), matching its pin hole with pin hole in spool.
Then insert pin(874).
- ※ Insert pin in feedback lever a little to ease operation.
 - ※ Take care not to mistake direction of feedback lever.

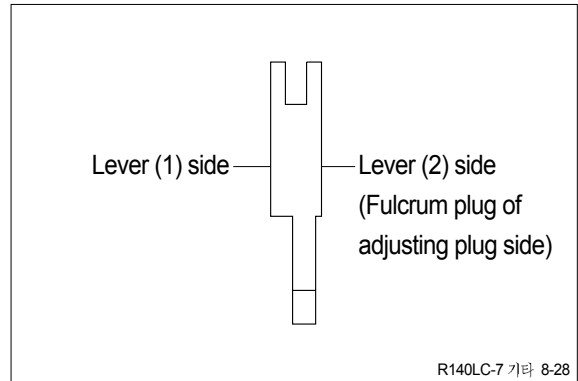

- (6) Put pilot piston(643) into pilot hole of casing.
- ※ Confirm that pilot piston slides smoothly without binding.
- (7) Put pin force-fitted in lever(2, 613) into groove of pilot piston.
Then fix lever(2).

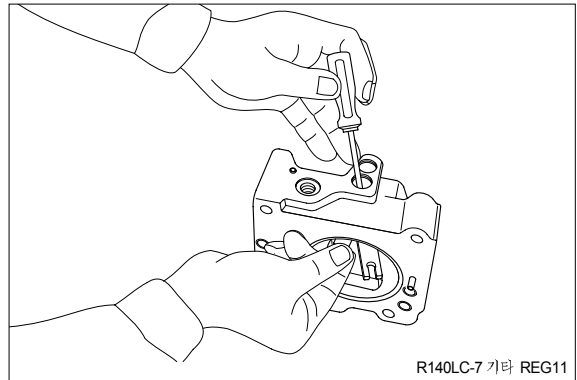

- (8) Fit fulcrum plug(614) so that pin force-fitted in fulcrum plug(614) can be put into pin hole of lever(2).
Then fix locking ring(858).
- (9) Insert adjusting plug(615) and fit locking ring.
- ※ Take care not to mistake inserting holes for fulcrum plug and adjusting plug.
- At this point in time move feedback lever to confirm that it has no large play and is free from binding.

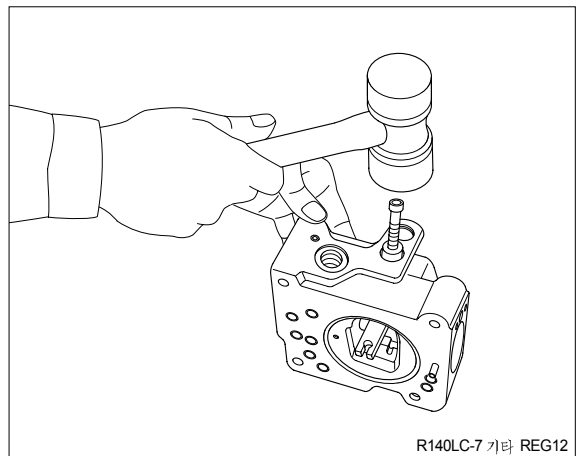

- (10) Fit return spring(654) and spring seat (653) into spool hole and attach snap ring (814).

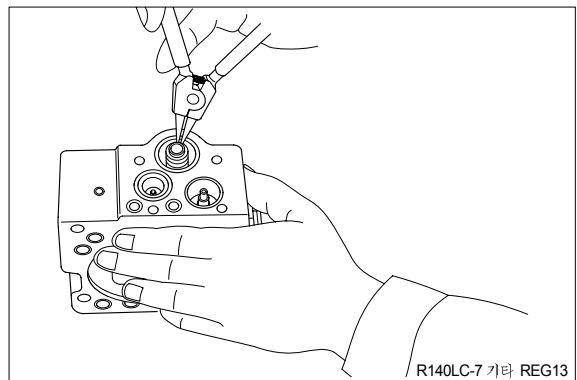

- (11) Fit set spring(655) to spool hole and put compensating piston(621) and piston case(622) into compensating hole.
Fit pilot cover(641) and tighten it with hexagonal socket head screws(436, 438).

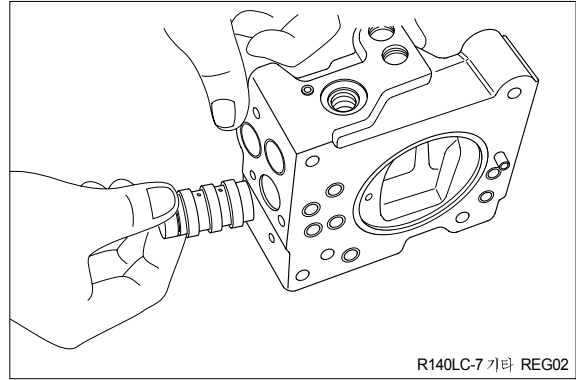

- (12) Put spring seat(644), pilot spring(646) and adjusting ring(Q, 645) into pilot hole.
Then fix spring seat(624), inner spring (626) and outer spring(625) into compensating hole.
※ When fitting spring seat, take care not to mistake direction of spring seat.

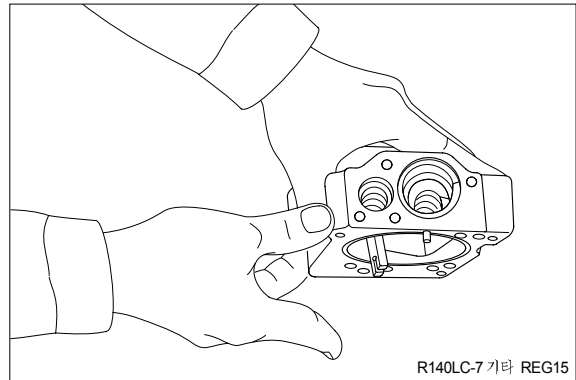

- (13) Install cover(C, 629) fitted with adjusting screws(628, 925), adjusting ring(C, 627), lock nut(630), hexagon nut(801) and adjusting screw(924).
Then tighten them with hexagonal socket head screws(438).

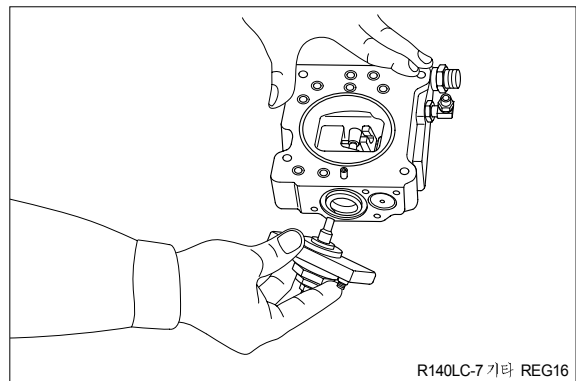

This completes assembly.

GROUP 4 MAIN CONTROL VALVE

1. REMOVAL AND INSTALL OF MOTOR

1) REMOVAL

- (1) Lower the work equipment to the ground and stop the engine.
- (2) Operate the control levers and pedals several times to release the remaining pressure in the hydraulic piping.
- (3) Loosen the breather slowly to release the pressure inside the hydraulic tank.

▲ Escaping fluid under pressure can penetrate the skin causing serious injury.

※ When pipes and hoses are disconnected, the oil inside the piping will flow out, so catch it in oil pan.

- (4) Remove bolts and disconnect pipe.
- (5) Disconnect pilot line hoses.
- (6) Disconnect pilot piping.
- (7) Sling the control valve assembly and remove the control valve mounting bolt.
· Weight : 80kg(180lb)
- (8) Remove the control valve assembly.
When removing the control valve assembly, check that all the piping have been disconnected.

2) INSTALL

- (1) Carry out installation in the reverse order to removal.
- (2) Bleed the air from below items.
 - ① Cylinder(Boom, arm, bucket)
 - ② Swing motor
 - ③ Travel motor※ See each item removal and install.
- (3) Confirm the hydraulic oil level and recheck the hydraulic oil leak or not.

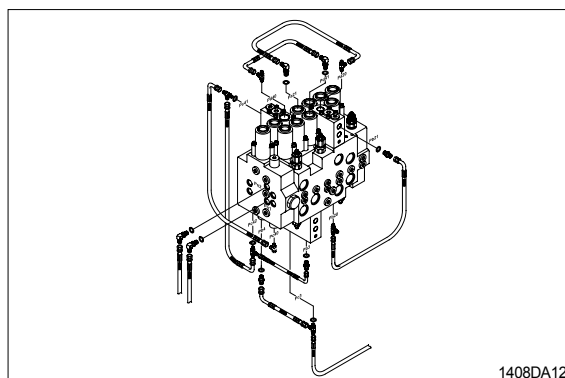
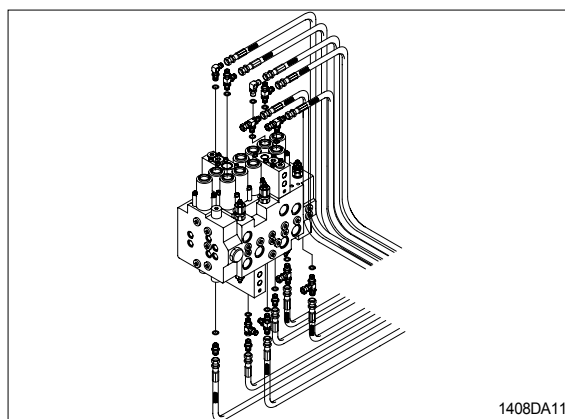
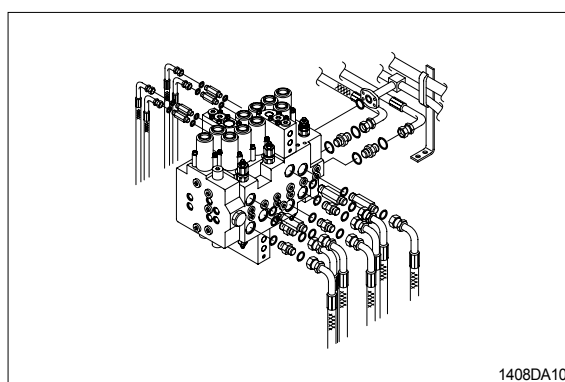

2. STRUCTURE(1/4)

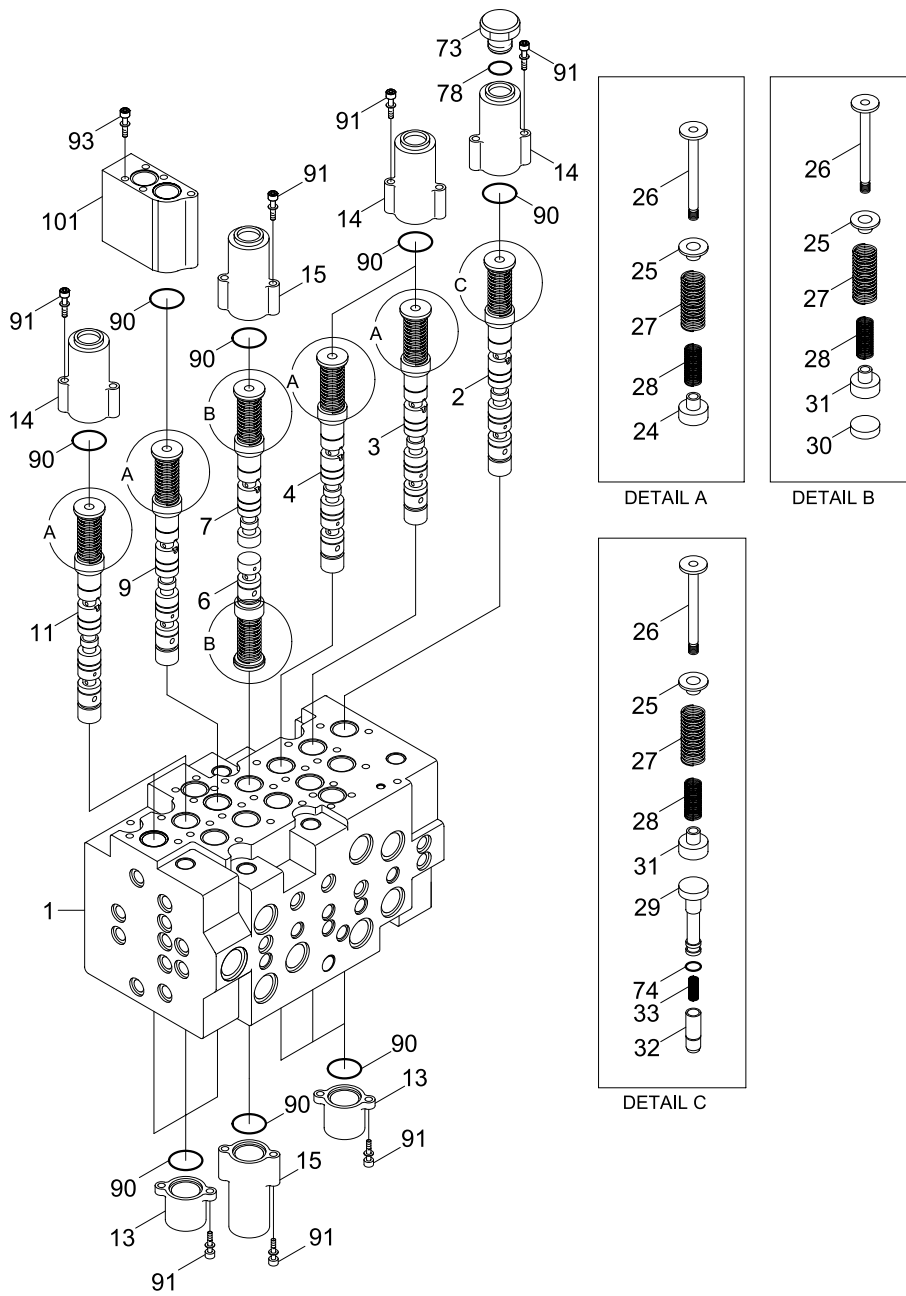

- | | | | | | |
|----|-------------|----|---------------|-----|--------------------|
| 1 | Body | 15 | Cover-pilot | 32 | Valve-check |
| 2 | Spool | 24 | Holder-spring | 33 | Spring-check valve |
| 3 | Spool | 25 | Holder-spring | 73 | Plug |
| 4 | Spool | 26 | End-spool | 74 | O-ring |
| 6 | Spool | 27 | Spring | 78 | O-ring |
| 7 | Spool | 28 | Spring | 90 | O-ring |
| 9 | Spool | 29 | Stopper | 91 | Bolt-socket head |
| 11 | Spool | 30 | Stopper | 93 | Bolt-socket head |
| 13 | Cover-pilot | 31 | Holder-spring | 101 | Lock-valve |
| 14 | Cover-pilot | | | | |

1408DA13

STRUCTURE(2/4)

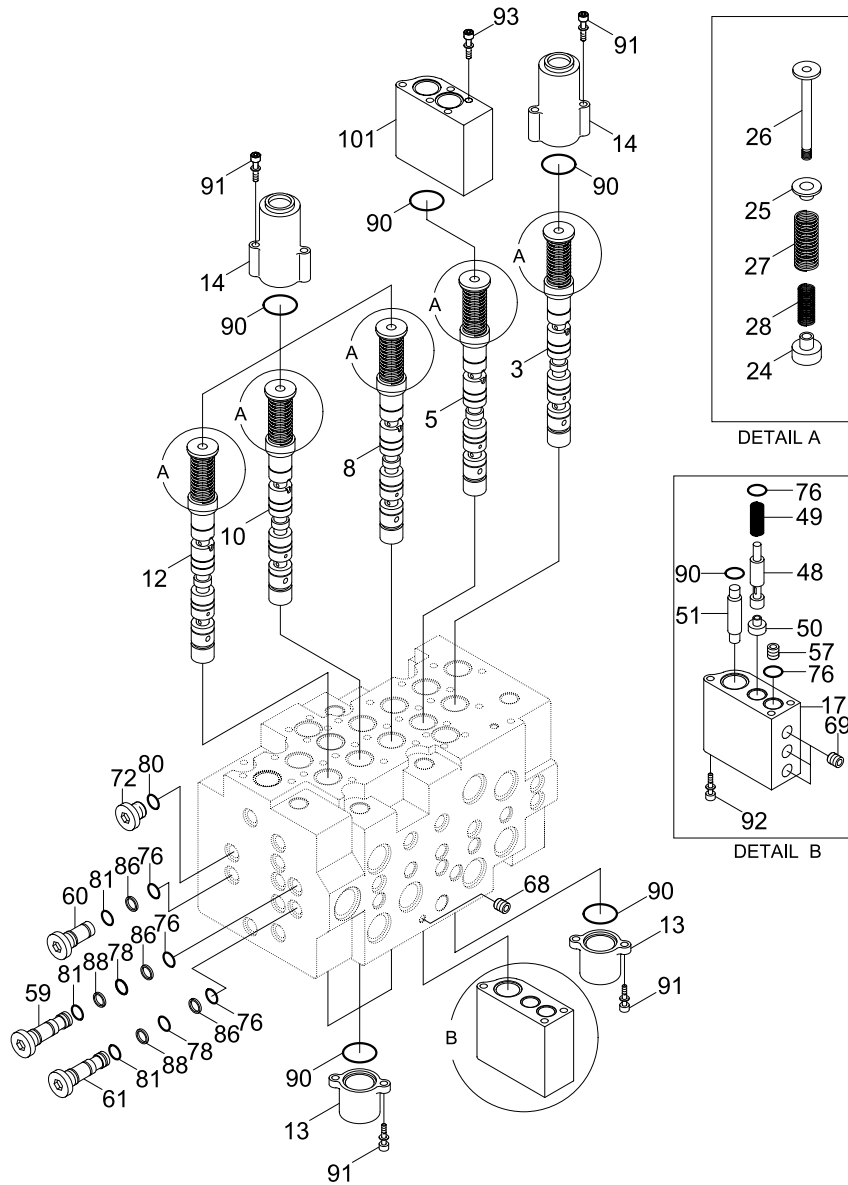

- | | | | | | |
|----|---------------|----|------------------|-----|------------------|
| 3 | Spool | 28 | Spring | 76 | O-ring |
| 5 | Spool | 48 | Spool-selector | 78 | O-ring |
| 8 | Spool | 49 | Spring | 80 | O-ring |
| 10 | Spool | 50 | Stopper | 81 | O-ring |
| 12 | Spool | 51 | Piston | 86 | Back-up ring |
| 13 | Cover-pilot | 57 | Restrictor | 88 | Back-up ring |
| 14 | Cover-pilot | 59 | Plug | 90 | O-ring |
| 17 | Cover-pilot | 60 | Plug | 91 | Bolt-socket head |
| 24 | Holder-spring | 61 | Restrictor | 92 | Bolt-socket head |
| 25 | Holder-spring | 68 | Plug-socket head | 93 | Bolt-socket head |
| 26 | End-spool\ | 69 | Plug-socket head | 101 | Lock-valve |
| 27 | Spring | 72 | Plug | | |

1408DA14

STRUCTURE(3/4)

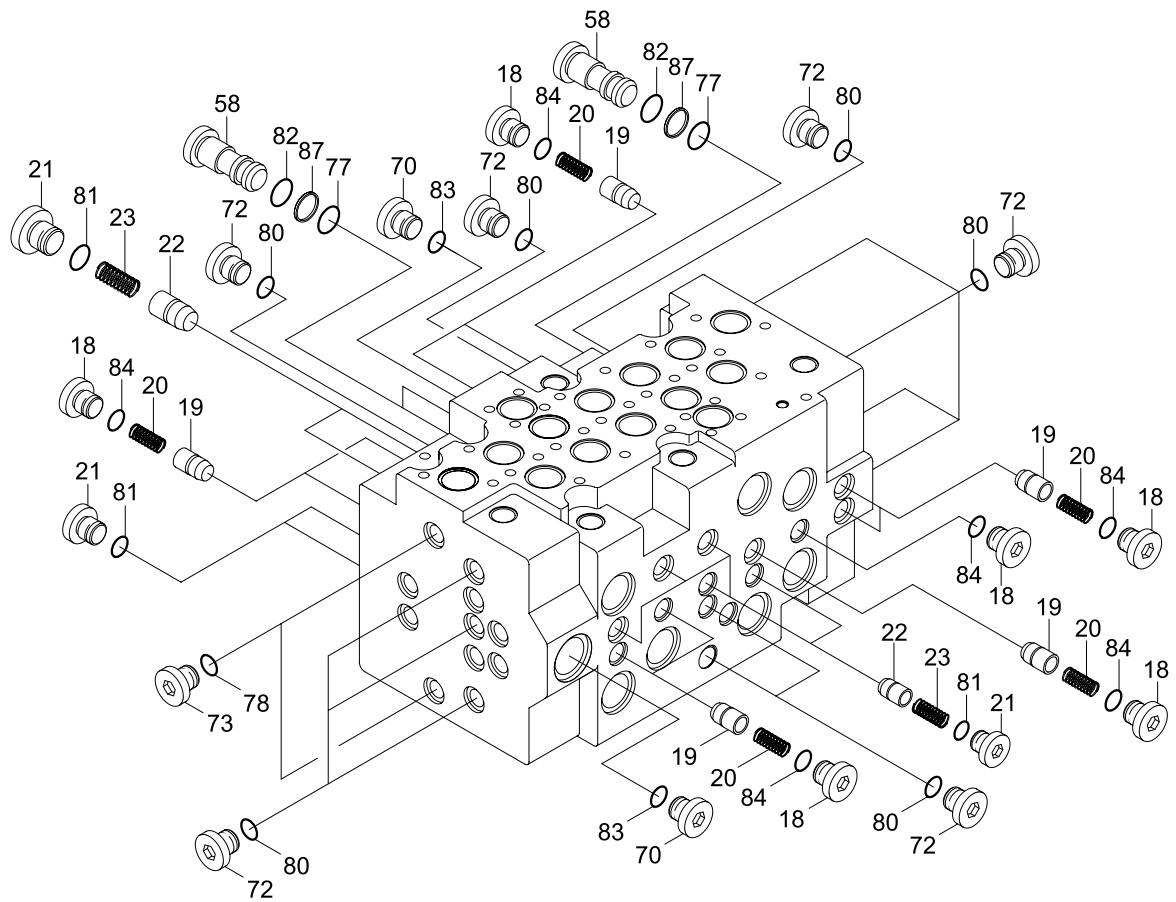

1408DA15

18	Plug	58	Plug	80	O-ring
19	Valve-check	70	Plug	81	O-ring
20	Spring-check valve	72	Plug	82	O-ring
21	Plug	73	Plug	83	O-ring
22	Valve-check	77	O-ring	84	O-ring
23	Spring-check valve	78	O-ring	87	Back-up ring

STRUCTURE(4/4)

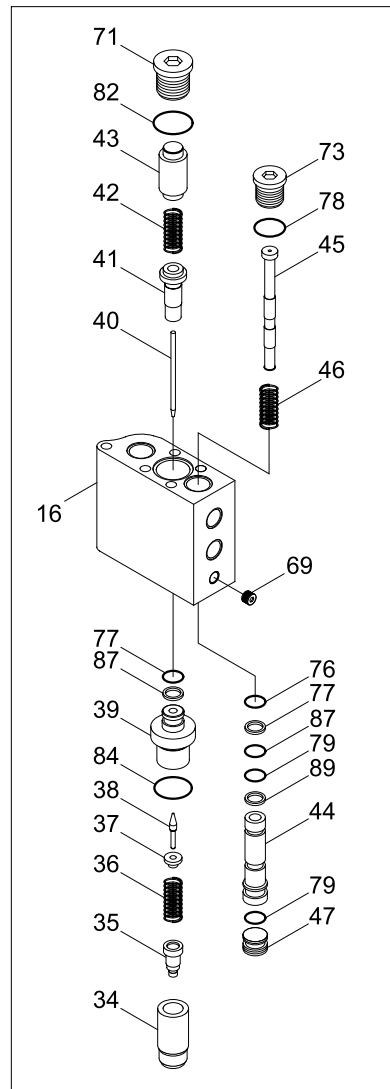
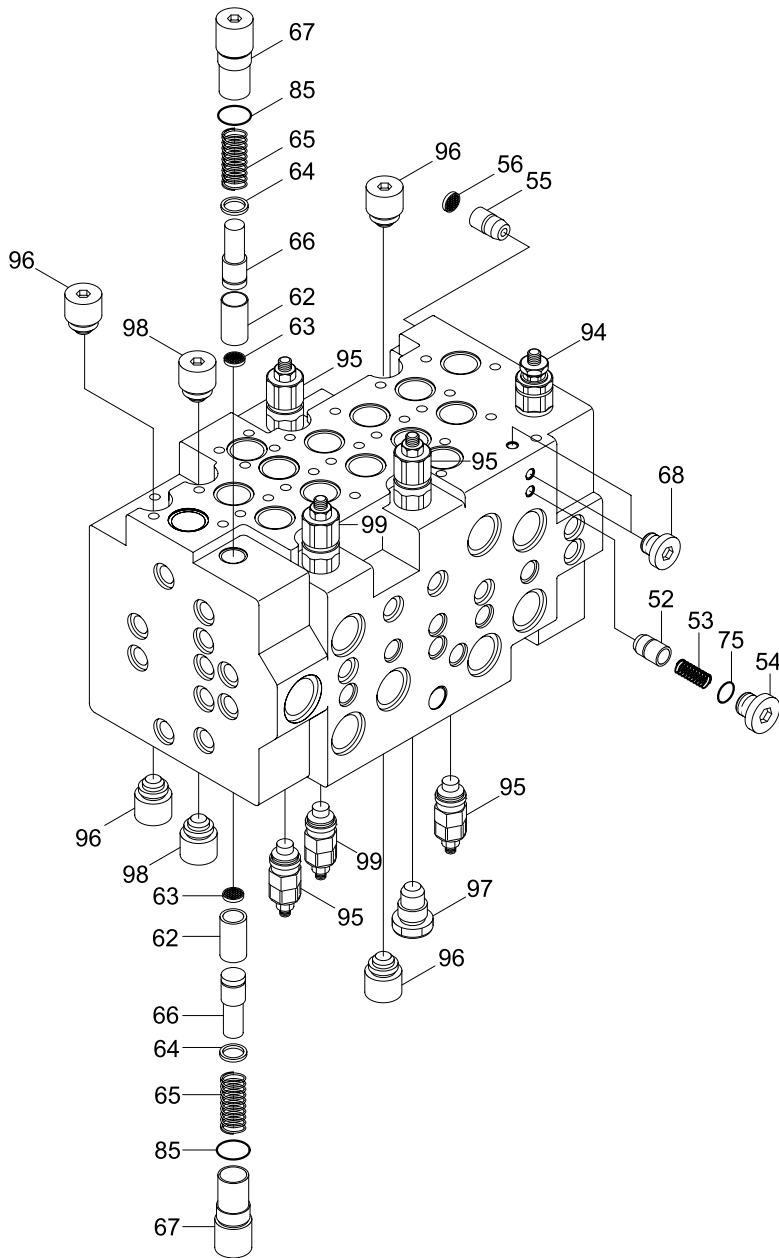

DETAIL OF LOCK VALVE

1408DA16

- | | | | | | |
|----|-----------------------|----|--------------------|----|-----------------------|
| 16 | Cover-pilot | 53 | Spring-check valve | 76 | O-ring |
| 34 | Valve-lock | 54 | Plug | 77 | O-ring |
| 35 | Restrictor-lock valve | 55 | Restrictor | 78 | O-ring |
| 36 | Spring-lock valve | 56 | Filter-coin type | 79 | O-ring |
| 37 | Holder-spring | 62 | Poppet-negative | 82 | O-ring |
| 38 | Poppet | 63 | Filter-coin type | 84 | O-ring |
| 39 | Seat-poppet | 64 | Holder-spring | 85 | O-ring |
| 40 | Piston | 65 | Spring-negative | 87 | Back-up ring |
| 41 | Guide-piston | 66 | Piston-negative | 89 | Back-up ring |
| 42 | Spring-lock valve | 67 | Socket-negative | 94 | Relief valve-main |
| 43 | Piston | 68 | Plug | 95 | Bolt-socket head |
| 44 | Socket-lock valve | 69 | Plug | 96 | Relief valve-overload |
| 45 | Spool-lock valve | 71 | Plug | 97 | Plug-relief valve |
| 46 | Spring-lock valve | 73 | Plug | 98 | Plug-relief valve |
| 47 | Plug-lock valve | 75 | O-ring | 99 | Relief valve-overload |
| 52 | Valve-check | | | | |

3. DISASSEMBLY AND ASSEMBLY

1) GENERAL PRECAUTIONS

- (1) All hydraulic components are manufactured to a high precision. Consequently, before disassembling and assembling them, it is essential to select an especially clean place.
- (2) In handling a control valve, pay full attention to prevent dust, sand, etc. from entering into it.
- (3) When a control valve is to be removed from the machine, apply caps and masking seals to all ports. Before disassembling the valve, recheck that these caps and masking seals are fitted completely, and then clean the outside of the assembly. Use a proper bench for working. Spread paper or a rubber mat on the bench, and disassemble the valve on it.
- (4) Support the body section carefully when carrying or transferring the control valve. Do not lift by the exposed spool, end cover section etc.
- (5) After disassembling and assembling of the component it is desired to carry out various tests (For the relief characteristics, leakage, flow resistance, etc.), but hydraulic test equipment is necessary for these tests. Therefore, even when its disassembling can be carried out technically, do not disassemble such components that cannot be tested, adjusted, and so on. Additionally one should always prepare clean cleaning oil, hydraulic oil, grease, etc. beforehand.

2) TOOLS

Before disassembling the control valve, prepare the following tools beforehand.

Name of tool	Quantity	Size(mm)
Vice mounted on bench(Soft jaws)	1 unit	
Hexagon wrench	Each 1 piece	5, 6, 10, 12 and 14
Socket wrench	Each 1 piece	27 and 32
Spanner	Each 1 piece	32(Main relief valve)

3) DISASSEMBLY

(1) Disassembly of spools without holding valve

- ① Loosen hexagon socket head bolts with washer
(Hexagon wrench : 5mm)
 - ② Remove the pilot cover.
- ※ Pay attention not to lose the O-ring under the pilot cover.
- ③ Remove the spool assembly from the body by hand slightly.
- ※ When extracting each spool from its body, pay attention not to damage the body.
 - ※ When extracting each spool assembly, it must be extracted from spring side only.
 - ※ When any abnormal parts are found, replace it with completely new spool assembly.
 - ※ When disassembled, tag the components for identification so that they can be reassembled correctly.

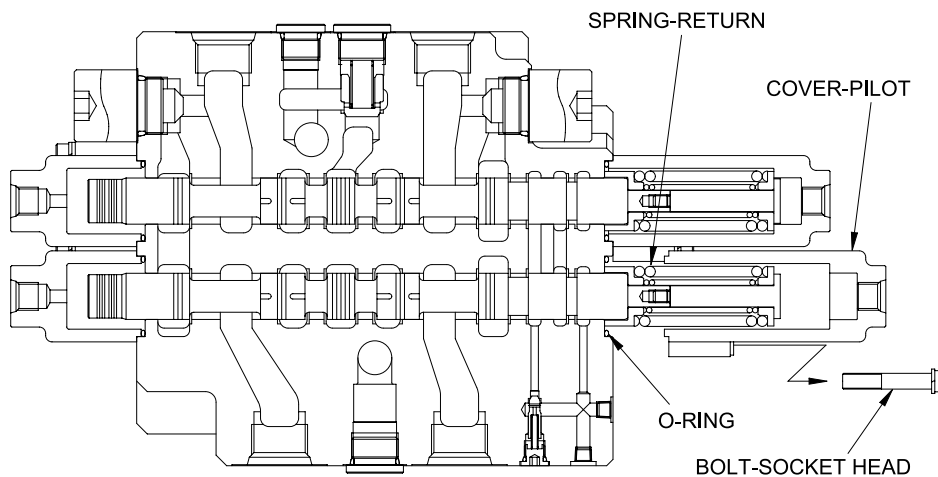

1408DA17

(2) Disassembly of spools with holding valve(Boom 1, Arm 1 spool)

- ① Loosen hexagon socket head bolts with washer
(Hexagon wrench : 5mm)
- ② Remove the pilot cover with internal parts.
 - ※ Pay attention not to lose the O-ring and the poppet under the pilot cover.
 - ※ Pay attention not to damage the "piston A" under pilot cover.
- ③ Remove the spool assembly from the body by hand slightly.
 - ※ When extracting each spool from its body, pay attention not to damage the body.
 - ※ When extracting each spool assembly, it must be extracted from spring side only.
 - ※ When any abnormal parts are found, replace it with completely new spool assembly.
 - ※ When disassembled, tag the components for identification so that they can be reassembled correctly.

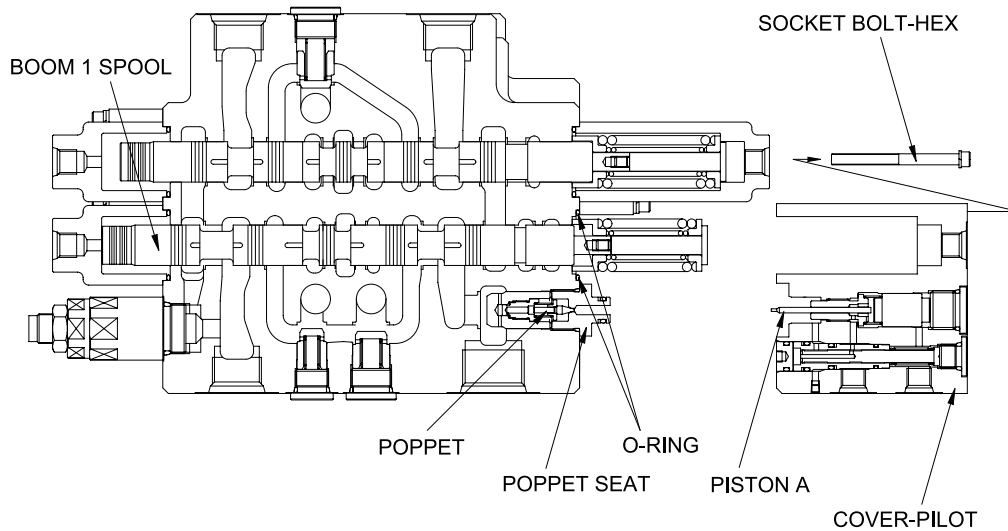

1408DA22

(3) Disassembly of the holding valve

- ① Remove the pilot cover with the holding valve as described on previous page.
 - ※ Do not disassemble internal parts of the pilot cover.
- ② Loosen the poppet seat and remove the poppet, the spring seat, the spring and the check.
(Spanner : 32mm)
 - ※ Pay attention not to lose the poppet.
 - ※ Do not disassemble internal parts of the check.

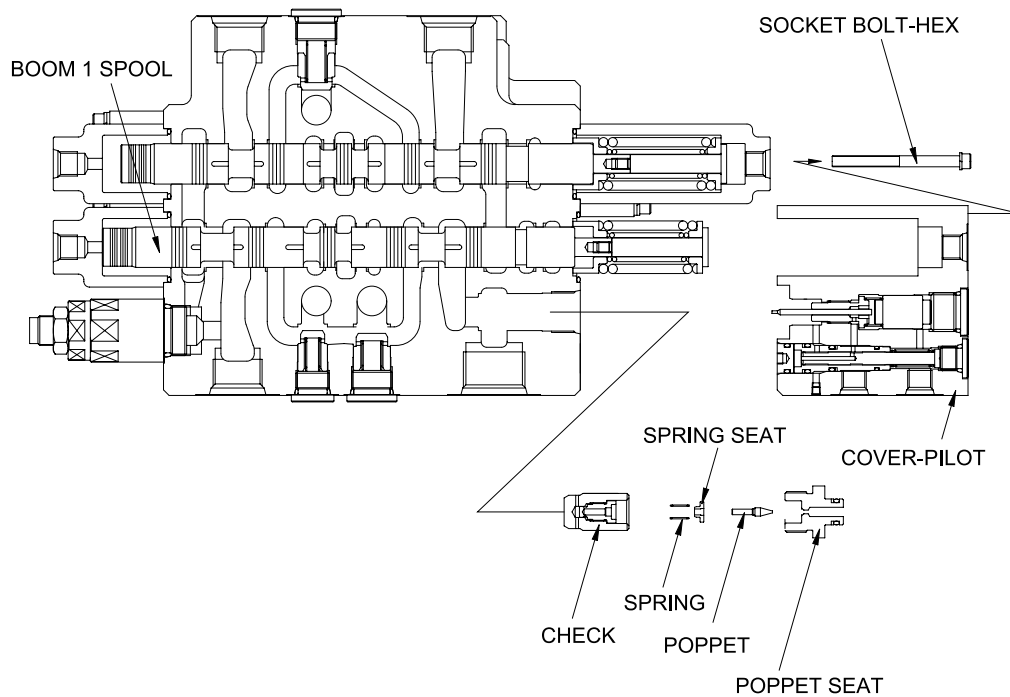

1408DA23

(4) Disassembly of the load check valve and the negative relief valve

① The load check valve

a. Fix the body to suitable work bench.

※ Pay attention not to damage the body.

b. Loosen the plug (Hexagon wrench : 10mm).

c. Remove the spring and the load check valve with pincers or magnet.

② The negative relief valve

a. Loosen the socket (Hexagon wrench : 12mm).

b. Remove the spring, the spring holder, the piston and the negative control poppet.

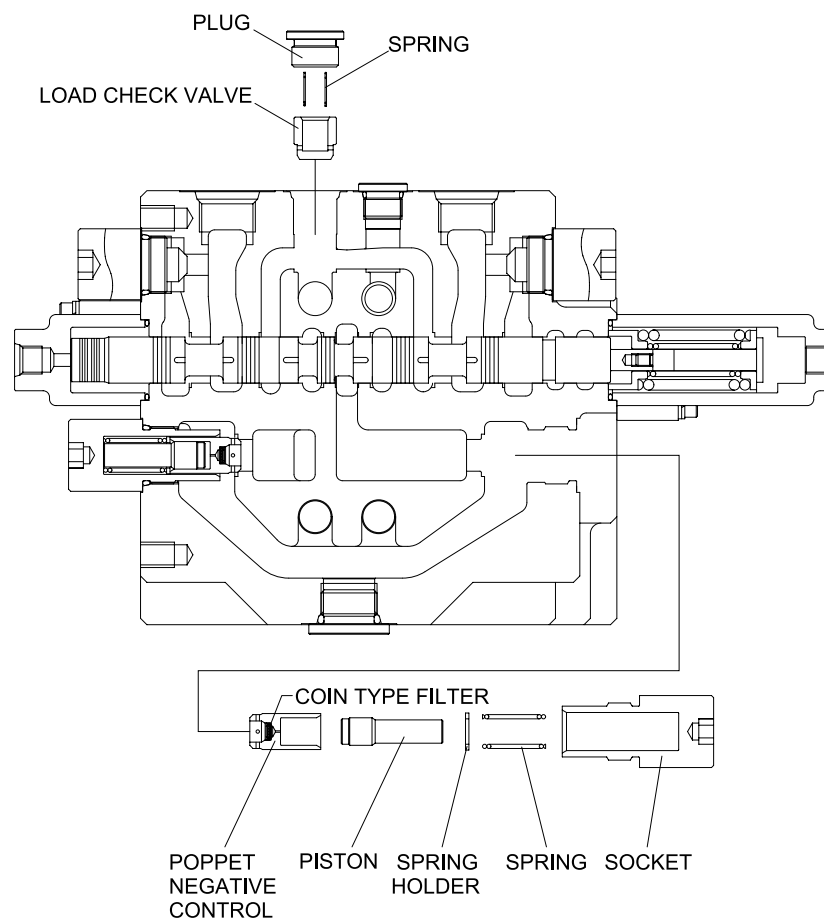

1408DA21

(5) Disassembly of the main and overload relief valve

- ① Fix the body to suitable work bench.
 - ② Remove the main relief valve.
(Spanner : 32mm)
 - ③ Remove the overload relief valve.
(Spanner : 32mm)
- ※ When disassembled, tag the relief valve for identification so that they can be reassembled correctly.
 - ※ Pay attention not to damage seat face.
 - ※ When any abnormal parts are found, replace it with completely new relief valve assembly.

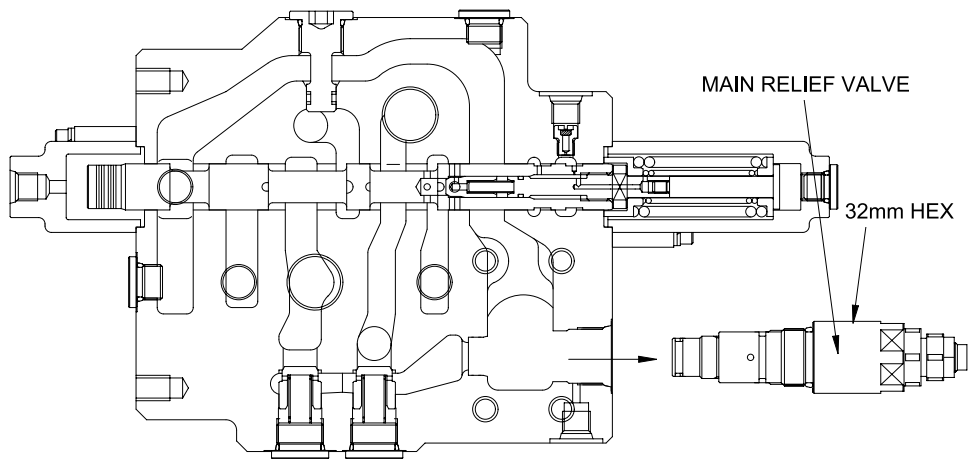

1408DA19

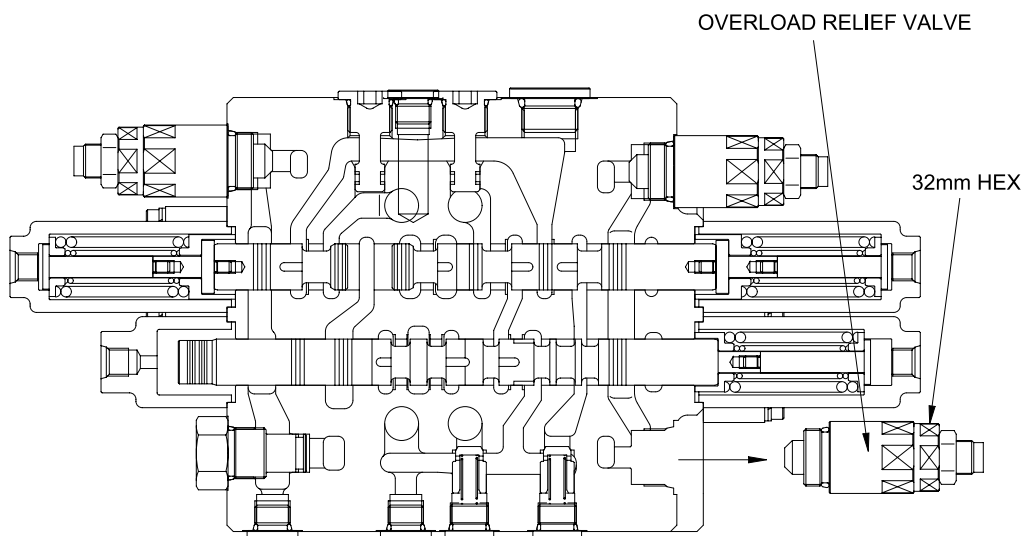

1408DA20

(6) Inspection after disassembly

Clean all disassembled parts with clean mineral oil fully, and dry them with compressed air. Then, place them on clean papers or cloths for inspection.

① Control valve

- a. Check whole surfaces of all parts for burrs, scratches, notches and other defects.
- b. Confirm that seal groove faces of body and block are smooth and free of dust, dent, rust etc.
- c. Correct dents and damages and check seat faces within the body, if any, by lapping.
 - ※ Pay careful attention not to leave any lapping agent within the body.
- d. Confirm that all sliding and fitting parts can be moved manually and that all grooves and path's are free foreign matter.
- e. If any spring is broken or deformed, replace it with new one.
- f. When a relief valve does not function properly, repair it, following it's the prescribed disassembly and assembly procedures.
- g. Replace all seals and O-rings with new ones.

② Relief valve

- a. Confirm that all seat faces at ends of all poppets and seats are free of defects and show uniform and consistent contact faces.
- b. Confirm manually that main poppet and seat can slide lightly and smoothly.
- c. Confirm that outside face of main poppet and inside face of seat are free from scratches and so on.
- d. Confirm that springs are free from breakage, deformation, and wear.
- e. Confirm that orifices of main poppet and seat section are not clogged with foreign matter.
- f. Replace all O-rings with new ones.
- g. When any light damage is found in above inspections, correct it by lapping.
- h. When any abnormal part is found, replace it with a completely new relief valve assembly.

4) ASSEMBLY

(1) General precaution

- ① In this assembly section, explanation only is shown.
For further understanding, please refer to the figures shown in the previous structure & disassembly section.
- ② Pay close attention to keeping all seals free from handling damage and inspect carefully for damage before using them.
- ③ Apply clean grease or hydraulic oil to the seal so as to ensure it is fully lubricated before assembly.
- ④ Do not stretch seals so much as to deform them permanently.
- ⑤ In fitting O-rings, pay close attention not to roll them into their final position in addition, a twisted O-ring cannot easily untwist itself naturally and could thereby cause inadequate sealing and thereby both internal and external oil leakage.
- ⑥ Tighten fitting bolts for all sections with a torque wrench adjusted to the respective tightening torque.
- ⑦ Do not reuse removed O-rings and seals.

(2) Load check valve

- ① Assemble the load check valve and spring.
- ② Put O-rings on to plug.
- ③ Tighten plug to the specified torque.
 - Hexagon wrench : 10mm
 - Tightening torque : 6~7kgf · m(43.4~50.6lbf · ft)

(3) Negative control relief valve

- ① Assemble the nega-con poppet, piston, spring holder and spring together into body.
- ② Put O-ring on to plug and tighten the latter to its specified torque.
 - Hexagon wrench : 12mm
 - Tightening torque : 8~9kgf · m(57.8~65.1lbf · ft)

(4) Main relief, port relief valves

Install main relief valve, overload relief valve into the body and tighten to the specified torque.

Component	Tools	Tightening torque	
		kgf · m	lbf · ft
Main relief valve	Spanner 32mm	8~9	57.8~65.1
Overload relief valve	Spanner 32mm	8~9	57.8~65.1

(5) Main spools

- ① Carefully insert the previously assembled spool assemblies into their respective bores within of body.
 - ※ Fit spool assemblies into body carefully and slowly. Do not under any circumstances push them forcibly in.

(6) Covers

- ① Fit spool covers to the non-spring assembly end of the spool, and tighten the hexagonal socket head bolts to the specified torque.
 - Hexagon wrench : 5mm
 - Tightening torque : 1~1.1kgf · m(7.2~7.9lbf · ft)
- ※ Confirm that O-rings have been fitted.
- ② Fit spring covers to the spring end for the spools, and tighten hexagon socket head bolts to the specified torque.
 - Hexagon wrench : 5mm
 - Tightening torque : 1~1.1kgf · m(7.2~7.9lbf · ft)
- ※ Confirm that O-rings have been fitted.

(7) Holding valves

- ① Assemble the check, spring seat and poppet together into body.
- ② Tighten the poppet seat to the specified torque.
 - Spanner : 26mm
 - Tightening torque : 6~7kgf · m(43.4~50.6lbf · ft)
- ③ Fit the "piston A" under pilot cover with internal parts into hole on the poppet seat.
- ④ Tighten hexagon socket head bolt to specified torque.
 - Hexagon wrench : 5mm
 - Tightening torque : 1~1.1kgf · m(7.2~7.9lbf · ft)

GROUP 5 SWING DEVICE

1. REMOVAL AND INSTALL OF MOTOR

1) REMOVAL

- (1) Lower the work equipment to the ground and stop the engine.
- (2) Operate the control levers and pedals several times to release the remaining pressure in the hydraulic piping.
- (3) Loosen the breather slowly to release the pressure inside the hydraulic tank.

▲ Escaping fluid under pressure can penetrate the skin causing serious injury.

※ When pipes and hoses are disconnected, the oil inside the piping will flow out, so catch it in oil pan.

- (4) Disconnect hose assembly(2).
- (5) Disconnect pilot line hoses(3,4,5,6,7,8).
- (6) Sling the swing motor assembly(1) and remove the swing motor mounting bolts (9).

※ Motor device weight : 32kg(70.5lb)

- (7) Remove the swing motor assembly.

※ When removing the swing motor assembly, check that all the piping have been disconnected.

2) INSTALL

- (1) Carry out installation in the reverse order to removal.
- (2) Bleed the air from the swing motor.
 - ① Remove the air vent plug.
 - ② Pour in hydraulic oil until it overflows from the port.
 - ③ Tighten plug lightly.
 - ④ Start the engine, run at low idling and check oil come out from plug.
 - ⑤ Tighten plug fully.
- (3) Confirm the hydraulic oil level and check the hydraulic oil leak or not.

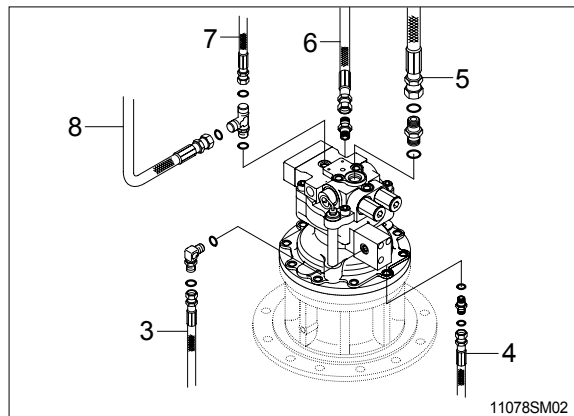
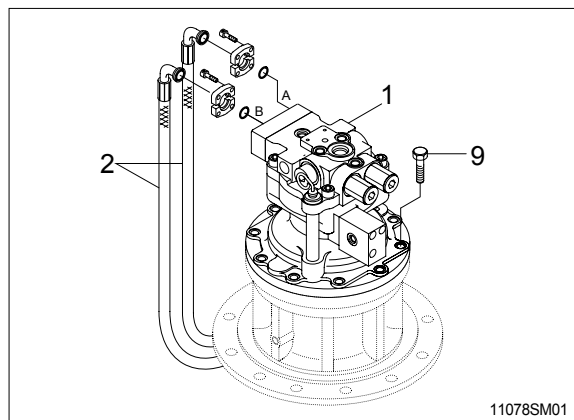

2. DISASSEMBLY AND ASSEMBLY OF SWING MOTOR

1) STRUCTURE

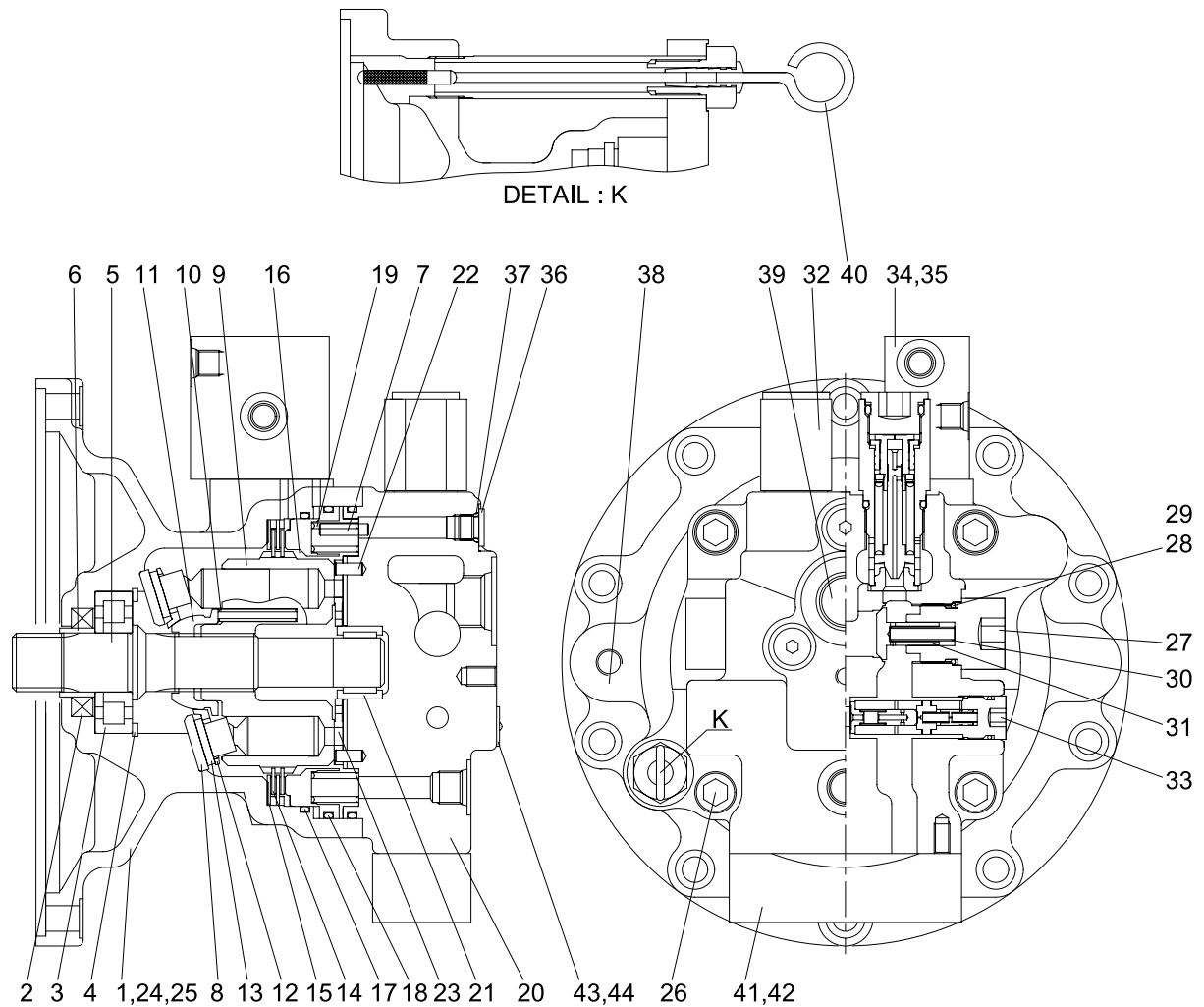

11072SM02

1	Body	16	Brake piston	31	Check
2	Oil seal	17	O-ring	32	Relief valve assembly
3	Roll bearing	18	O-ring	33	Reactionless valve assembly
4	Snap ring	19	Spring	34	Time delay valve assembly
5	Shaft	20	Rear cover	35	Wrench bolt
6	Bushing	21	Needle bearing	36	Plug
7	Pin	22	Pin	37	O-ring
8	Shoe plate	23	Valve plate	38	Plug
9	Cylinder block	24	O-ring	39	Plug
10	Spring	25	O-ring	40	Level gauge
11	Ball guide	26	Wrench bolt	41	Flange
12	Set plate	27	Plug	42	O-ring
13	Piston assembly	28	Back up ring	43	Name plate
14	Friction plate	29	O-ring	44	Rivet
15	Plate	30	Spring		

2) DISASSEMBLY

- (1) Lift the motor out. Clean the motor in kerosene and dry with compressed air.
 - ※ To avoid dust inside the motor, mask all the ports of the motor with tapes.

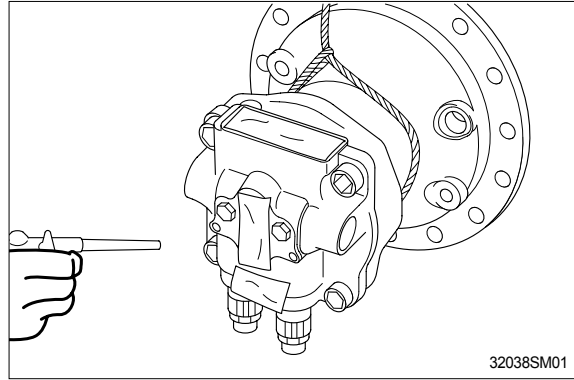

- (2) Loosen the drain plug to discharge oil in the body(1).

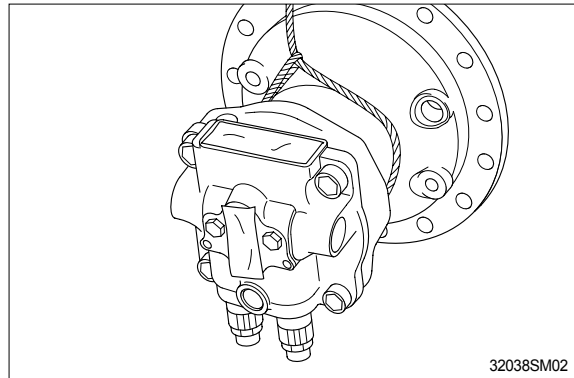

- (3) Fix the drive shaft(5) on the workbench with the end of output shaft down. Put matching marks on body (1) and valve rear cover(20) for easy reassembly.

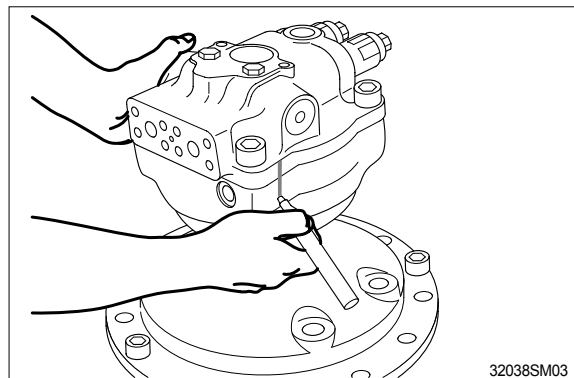

- (4) Remove the valve(34).

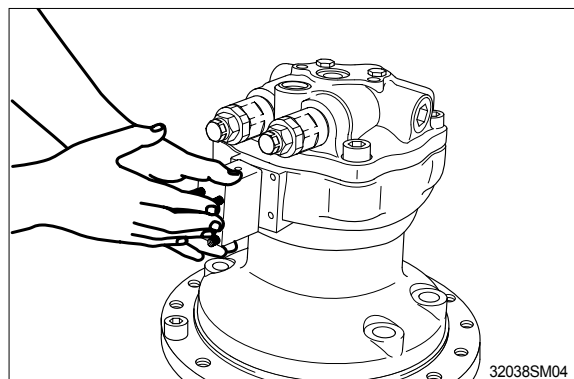

- (5) Remove the relief valve(32) from rear cover(20).

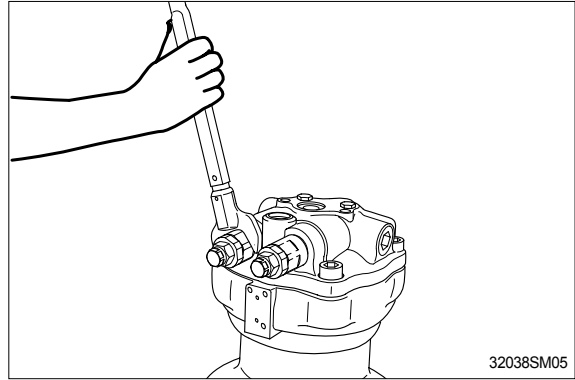

- (6) Remove plug(27) from rear cover(20) and spring(30), check(31).
※ Be careful not to damage the check seat assembly.

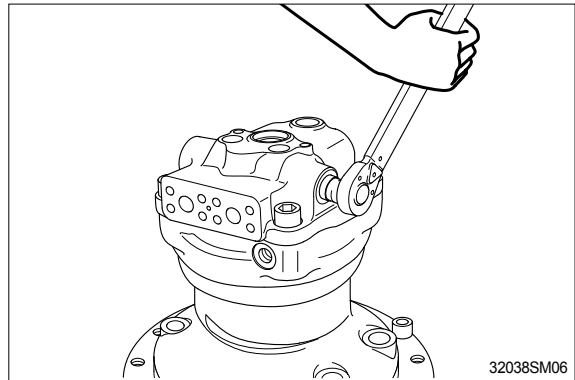

- (7) Remove rear cover(20) from body(1).
Then, remove the valve plate(23) from rear cover(20) with care.

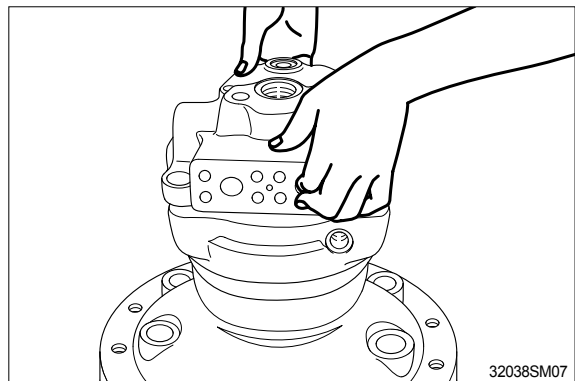

- (8) Remove the brake spring(19) from brake piston(16).

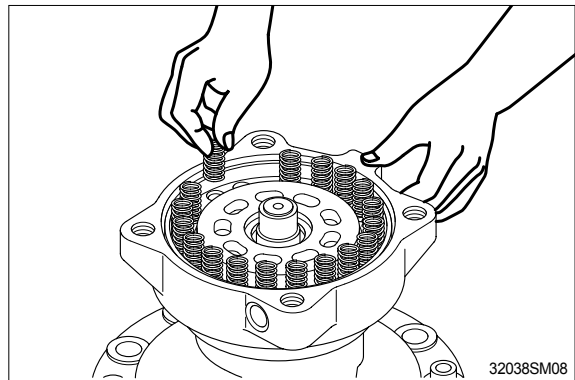

(9) Remove brake piston(16) from body(1).

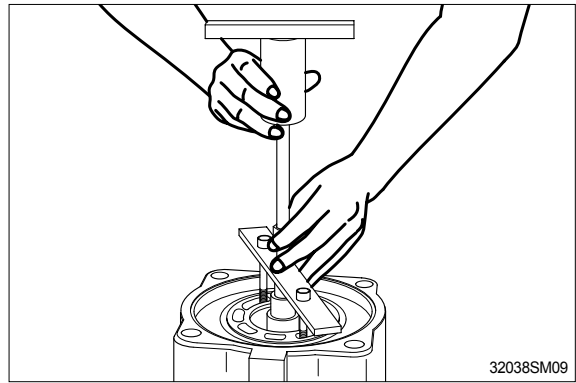

(10) Remove the cylinder(9) from the output shaft(5) with the motor positioned horizontally. Remove ball guide(11), set plate(12), piston(13) and shoe plate(8).

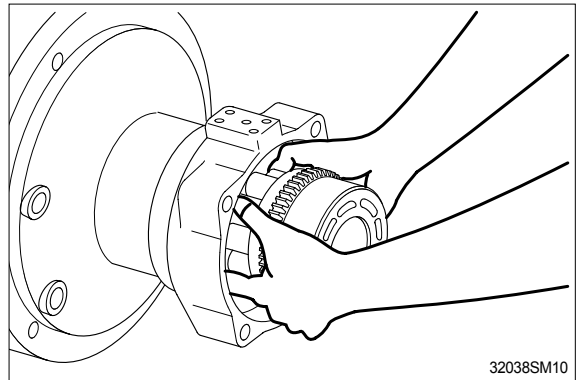

(11) Remove friction plate(14) and separate plate(15) from body(1).

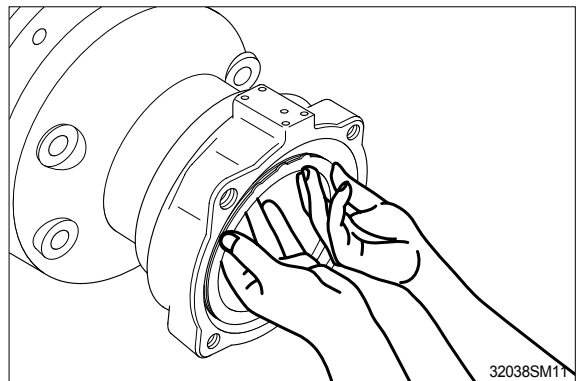

(12) Remove snap ring(4) and remove drive shaft(5) from body(1).

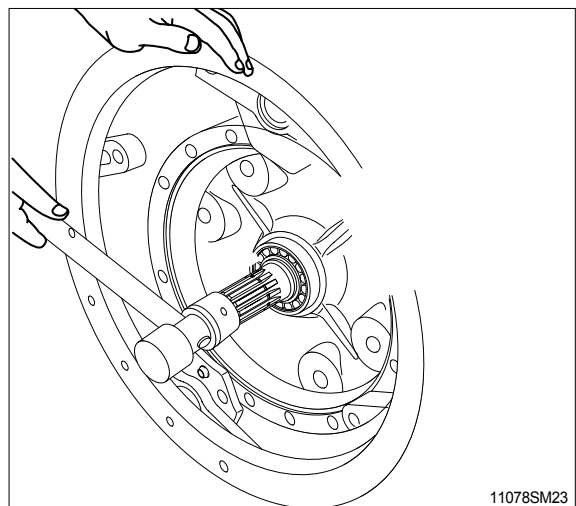

(13) Remove the cone of roller bearing(3) by press.

※ Do not reuse bearings.

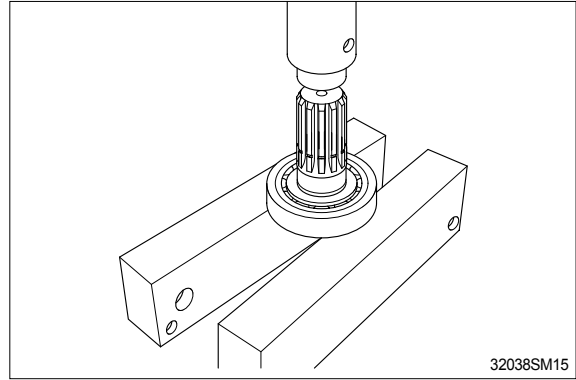
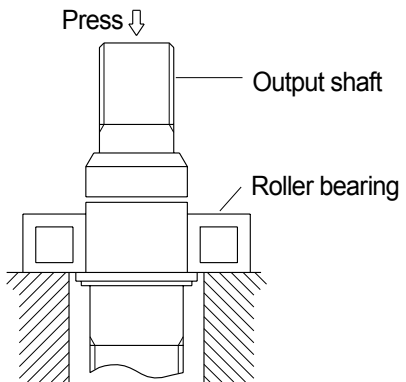

(14) Remove bushing(6) and oil seal(2) from body(1).

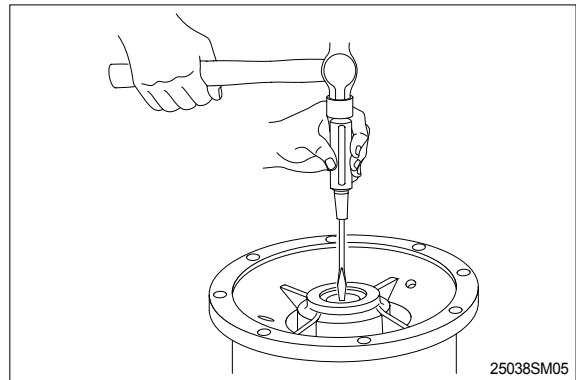

(15) Remove the needle bearing(21) from the rear cover(20) by using slide hammer bearing puller.

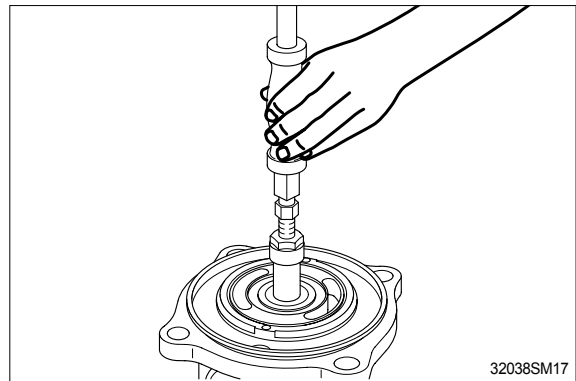

(16) When disassembling the relief valve, release the plug(3).
Remove the piston(7), spring seat(9), spring(8) and plunger(6) with the body(1) downwards.

※ Do not release the lock nut(15).

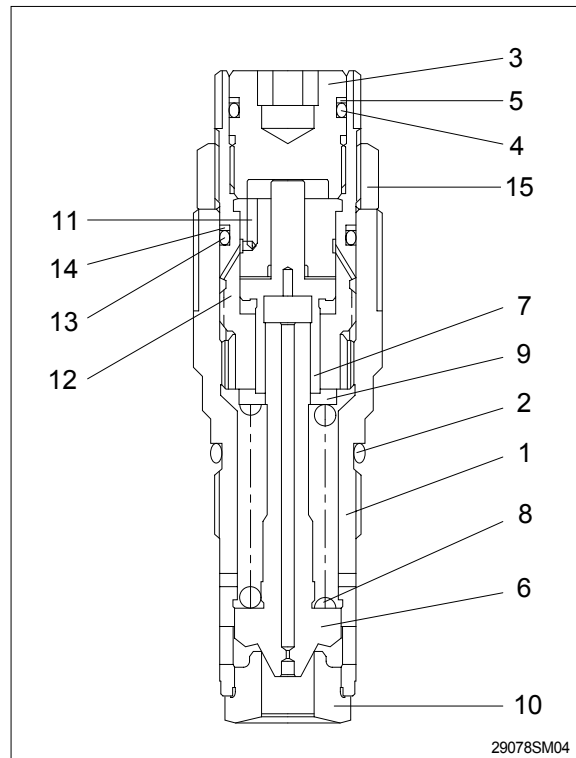

This completes disassembly.

3) ASSEMBLY

Do the reassembly in the reverse procedure of the disassembly.

- (1) Apply three bond of white color on outer surface of oil seal(2) and insert it to the body(1).

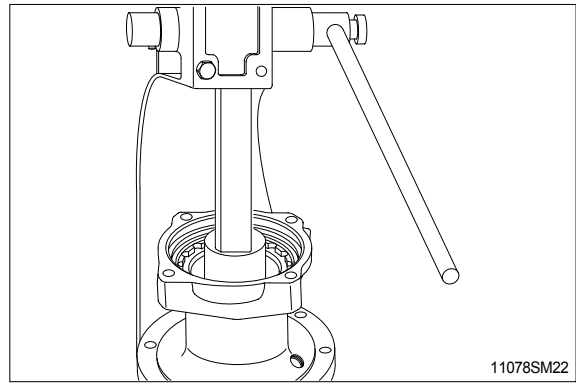

- (2) Install the roller bearing(3) to the drive shaft(5).

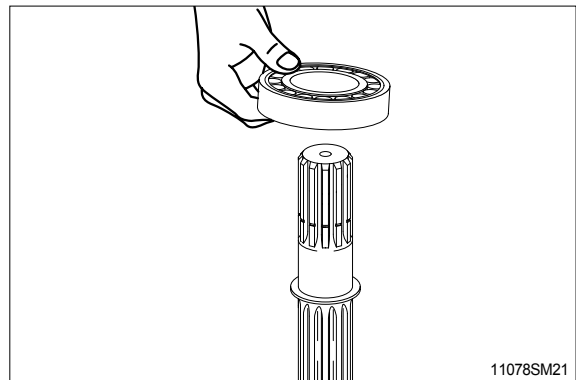

- (3) Insert the drive shaft(5) into the body(1) with the plastic hammer lightly.

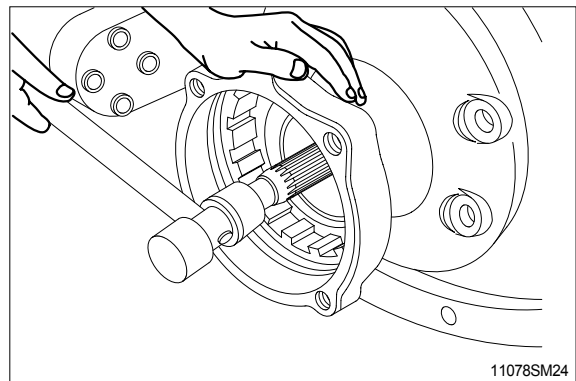

- (4) Install the snap ring(4) to the body(1).

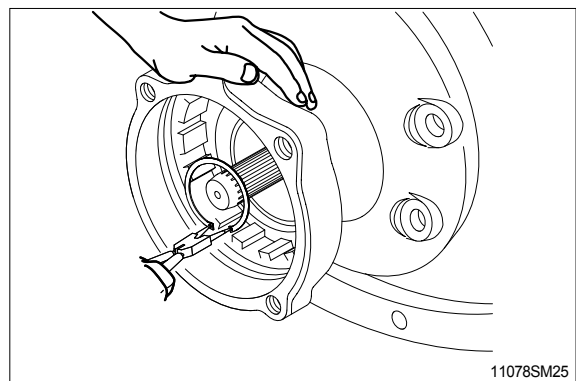

- (5) Insert the shoe plate(8) with the body(1) position horizontally.

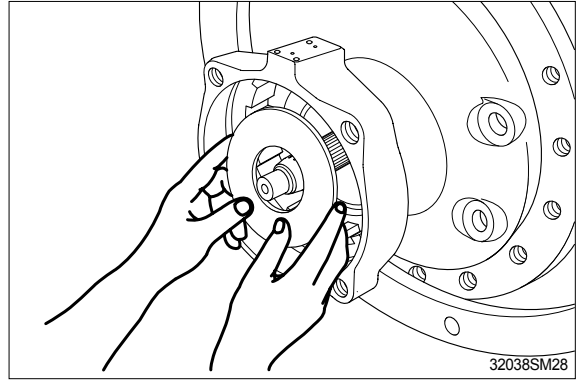

- (6) Insert the ball guide(11) into the cylinder (9).

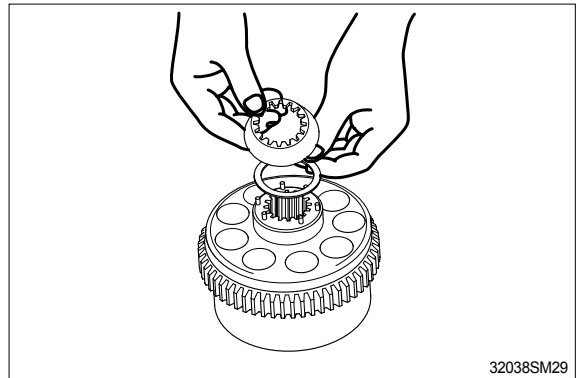

- (7) Install the piston sub-assembly(13) to the set plate(12).



- (8) Reassemble the piston assembly(9) to the body(1).

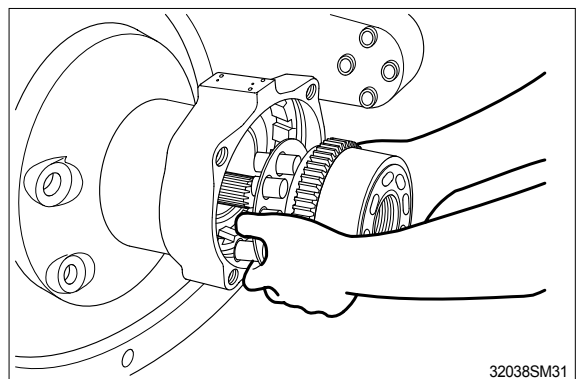

(9) Assembly friction plate(14) and plate(15) to the body(1).

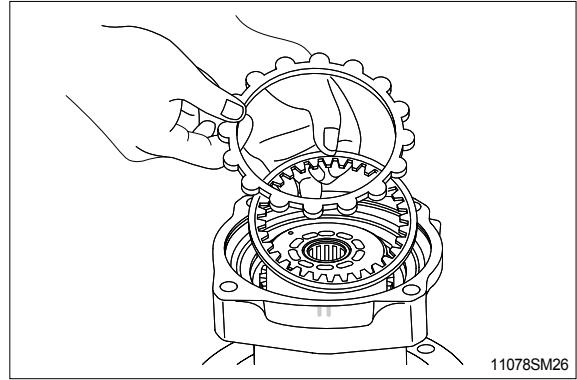

(10) Insert O-ring(17) inside the body(1).

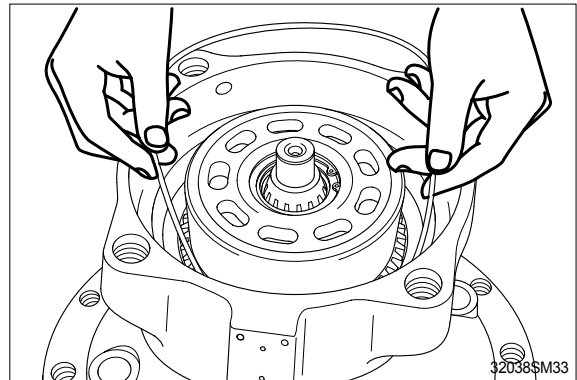

(11) Reassemble brake piston(16) to the body (1).

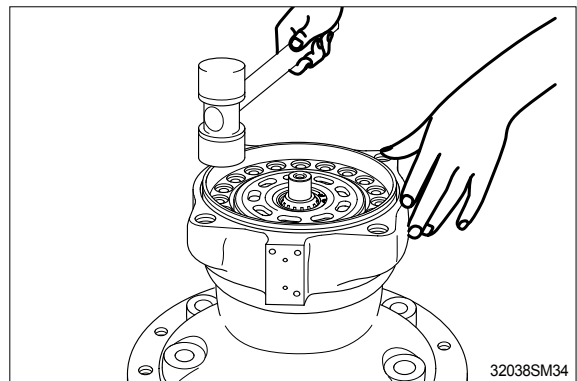

(12) Reassemble brake spring(19) to the brake piston(16).

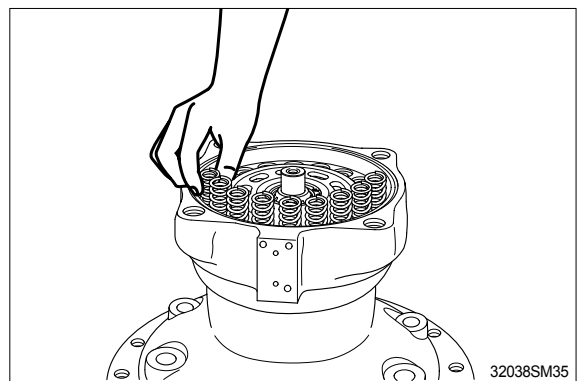

(13) When assembling the needle bearing(21), insert the needle bearing(21) into rear cover(20) by hammering.

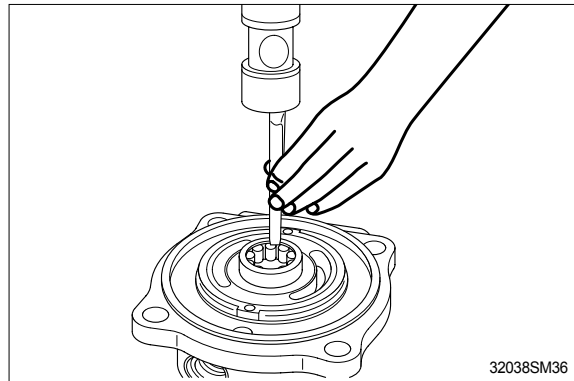

(14) Reassemble valve plate(23) to the rear cover(20) and reassemble O-ring(18).

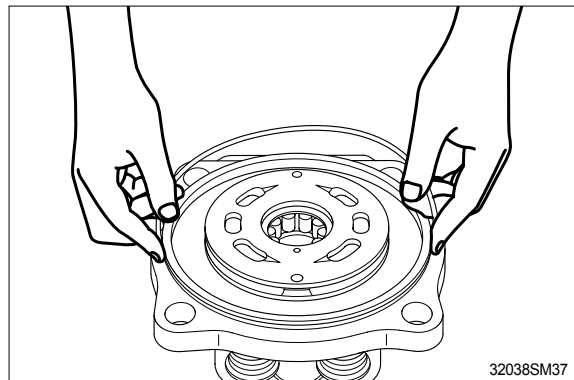

(15) Connect the rear cover(20) with the body (1) and tighten the wrench bolt(26).

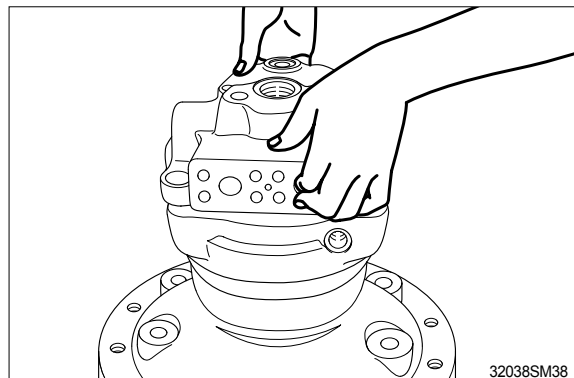

(16) Insert check(31) and spring(30) in the valve casing and install O-ring(29) and back up ring(28). Tighten plug(27) to the rear cover(20).

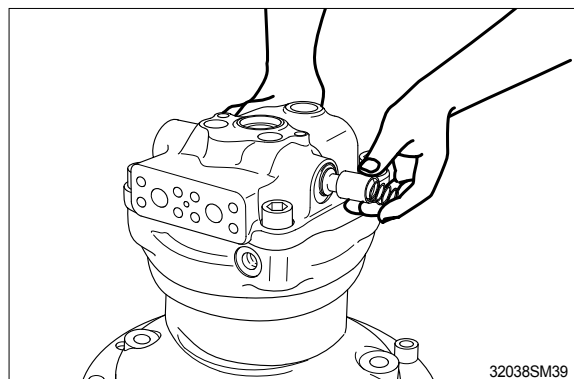

(17) Insert O-rings to the relief valve (32) and reassemble them to rear cover(20).

This completes assembly.

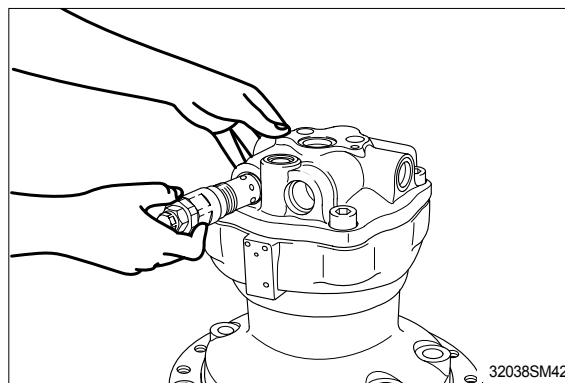

3. REMOVAL AND INSTALL OF REDUCTION GEAR

1) REMOVAL

- (1) Remove the swing motor assembly.
For details, see **removal of swing motor assembly**.
- (2) Sling reduction gear assembly(1) and remove mounting bolts(2).
- (3) Remove the reduction gear assembly.
 - Reduction gear device weight : 95kg
(209lb)



2) INSTALL

- (1) Carry out installation in the reverse order to removal.
 - Tightening torque : $29.7 \pm 4.5 \text{kgf} \cdot \text{m}$
($215 \pm 32.5 \text{lb} \cdot \text{ft}$)

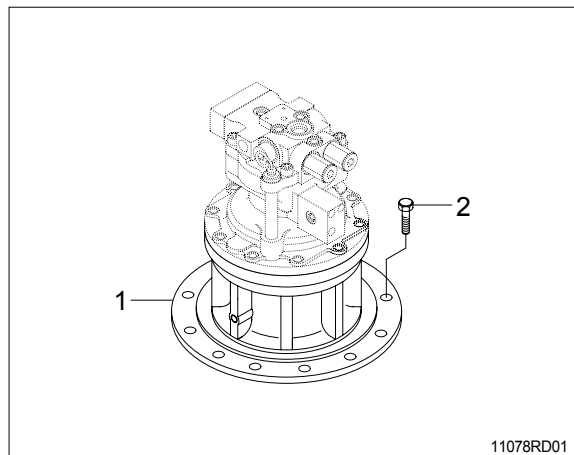

4. DISASSEMBLY AND ASSEMBLY OF REDUCTION GEAR

1) STRUCTURE

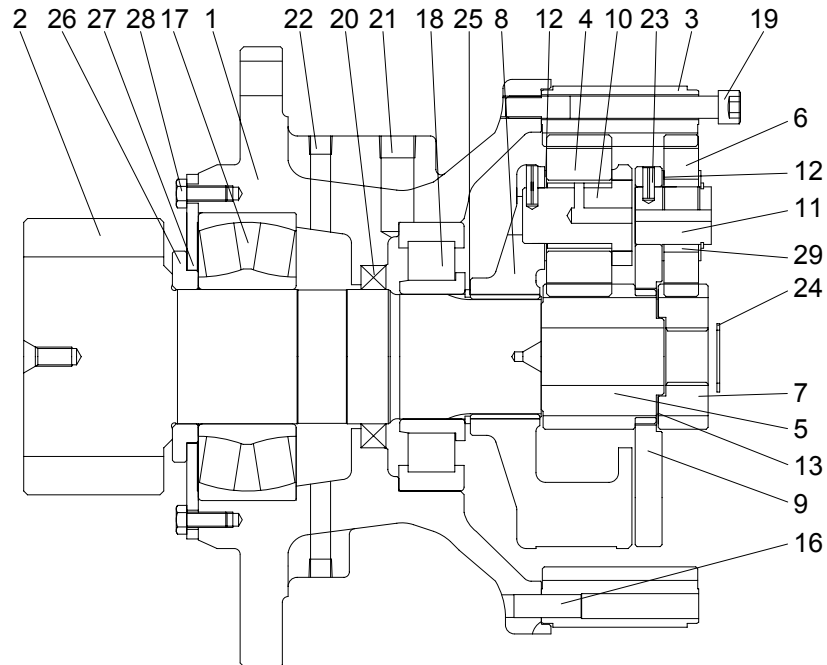

11072SM03

1	Casing	10	Pin No.2 assembly	21	Plug(B)
2	Drive shaft	11	Pin No.1	22	Plug(A)
3	Ring gear	12	Thrust washer(B)	23	Spring pin
4	Planet gear No.2	13	Thrust washer(A)	24	Stop ring
5	Sun gear No.2	16	Knock pin	25	Stop ring
6	Planet gear No.1	17	Sph roller bearing	26	Spacer
7	Sun gear No.1	18	Cyl roller bearing	27	Cover plate
8	Carrier No.2	19	Bolt	28	Bolt
9	Carrier No.1	20	Oil seal	29	Needle cage

2) DISASSEMBLY

- (1) Remove gauge bar(14) and gauge pipe (15) from the swing motor casing.
※ Pour the gear oil out of reduction gear into the clean bowl to check out the friction decrease.

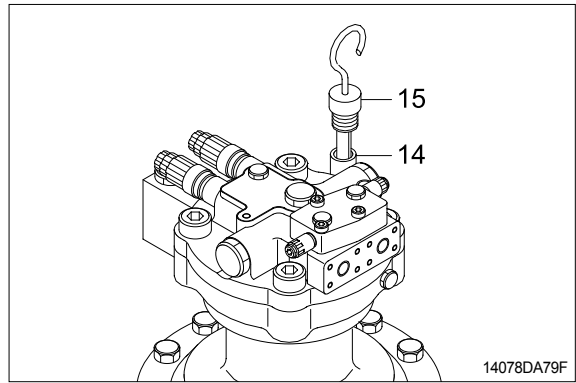

- (2) Loosen the socket bolts(19) to separate swing motor from reduction gear.

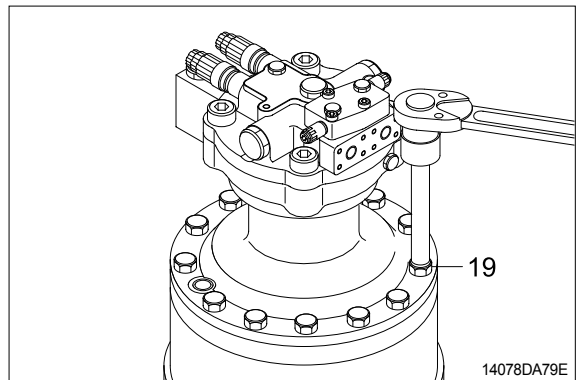

- (3) Remove stop ring(24) and then sun gear(7).

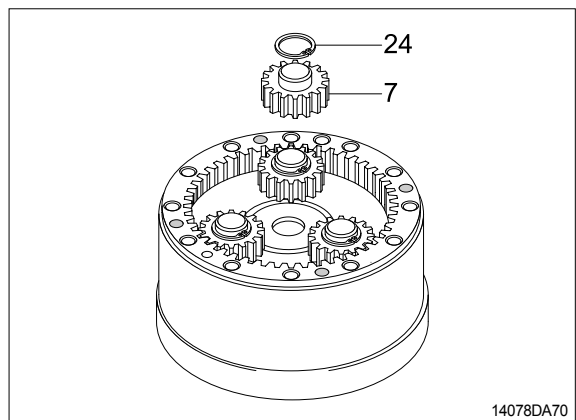

- (4) Tighten two M10 eye bolts to carrier(9) and lift up and remove carrier(9) as subassembly.

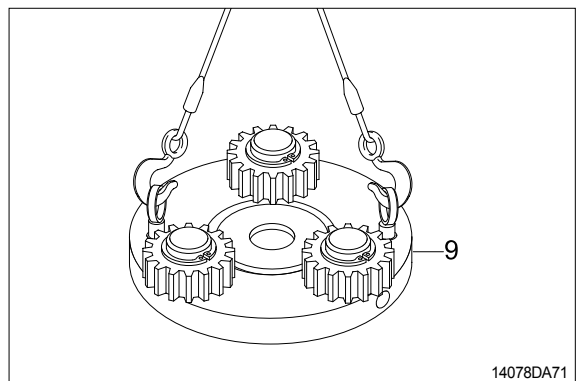

(5) Disassembling carrier1(9) assembly.

- ① Remove stop ring(24).
 - ② Remove thrust washer(12), planet gear1 (6), needle cage(29), and thrust washer(12) from the carrier.
 - ③ Using M8 solid drill, crush spring pin(23) so that the pin1(11) can be removed by hammering.
- ※ Do not reuse spring pin(23).
 - ※ Do not remove pin1(11), carrier1(9) and spring pin(23) but in case of replacement.
 - ※ Put matching marks on the planet gear1 (6) and the pin1(11) for easy reassembly.

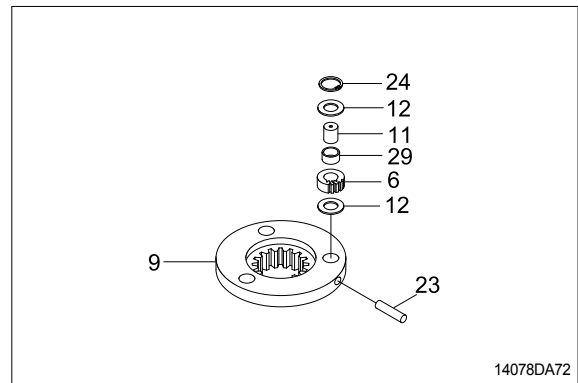

(6) Remove sun gear2(5) and thrust washer (13).

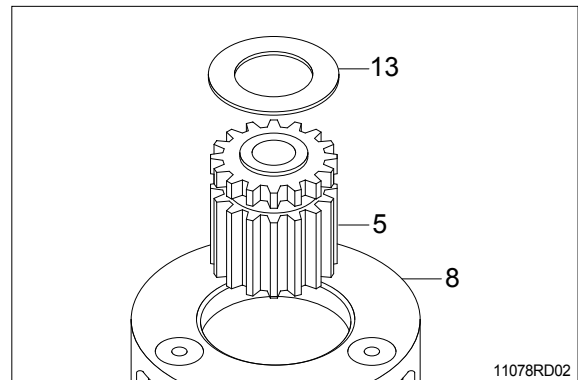

(7) Remove carrier2(8) assembly from casing (1).

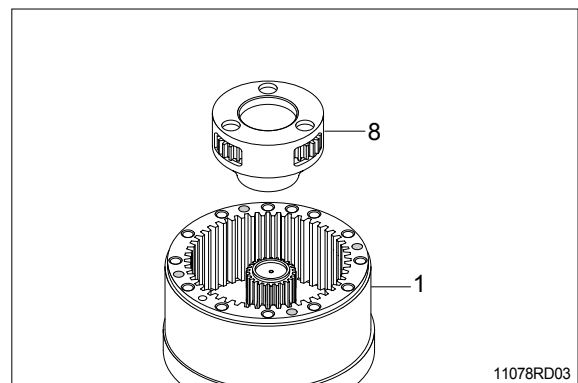

(8) Disassembling carrier2(8) assembly

- ① Using M8 solid drill, crush spring pin(23) so that the pin2(10) can be removed.
 - ※ Do not reuse spring pin(23).
- ② Remove pin2(10), planet gear2(4) and thrust washer(12) from the carrier2(8).
 - ※ Put matching marks on the planet gear2 (4) and the pin2(23) for easy reassembly.
 - ※ Do not disassemble pin2(23), carrier2(8) and spring pin(23) but in case of replacement.

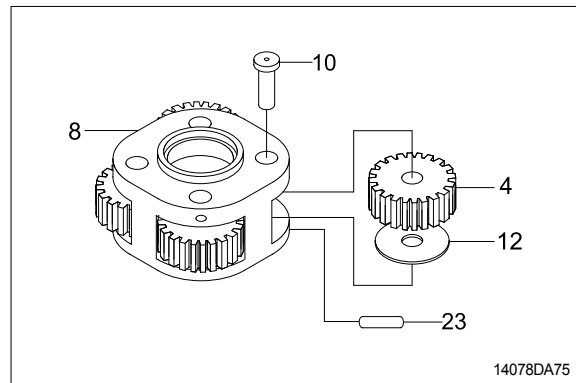

(9) Tighten two M16 eyebolt to the ring gear(3) and then lift the ring gear(3) out of casing(1).

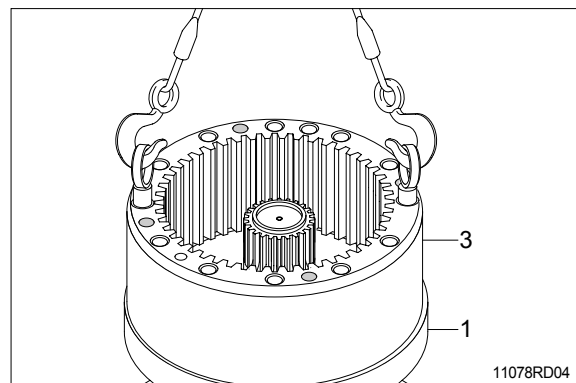

(10) Remove stop ring (25) from the drive shaft(2).

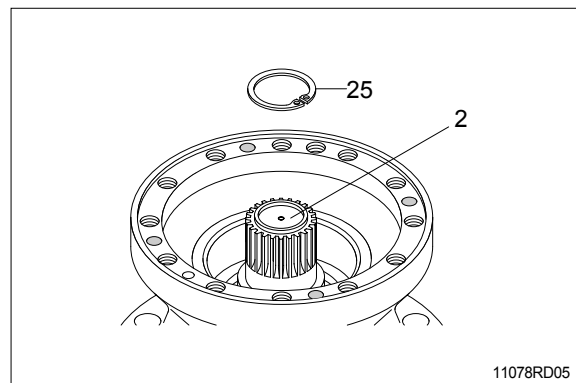

(11) Remove the bolt(28) and remove the drive shaft(2) with roller bearing(17), the spacer(26) and the cover plate(27).

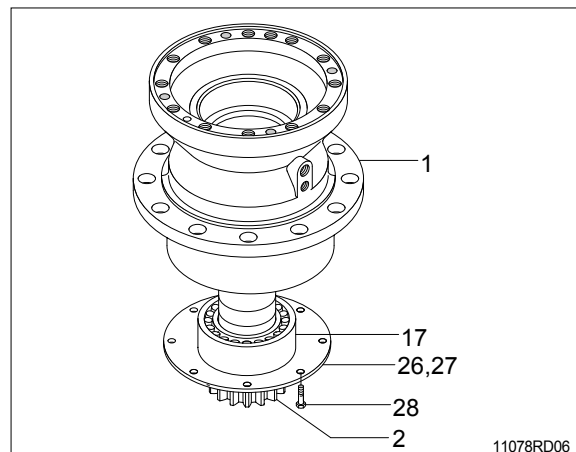

(12) Remove the roller bearing(17), the cover plate(27) and the spacer(26) from the drive shaft(2).

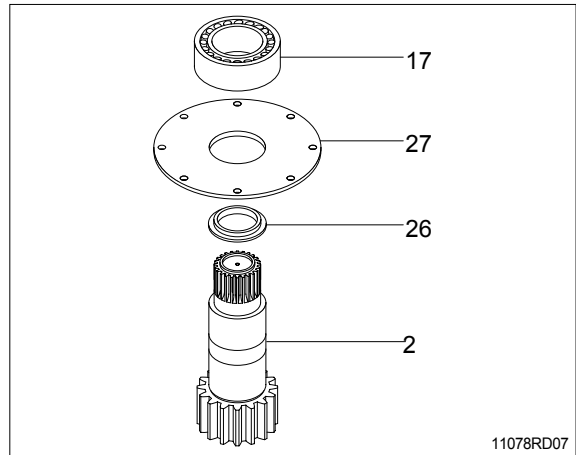

(13) Using the bearing disassembly tool, remove roller bearing(18).

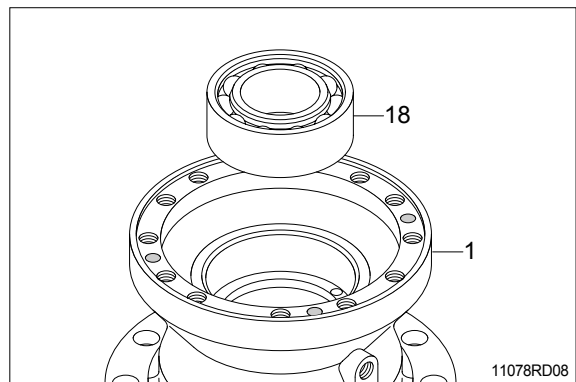

(14) Remove the oil seal(20).

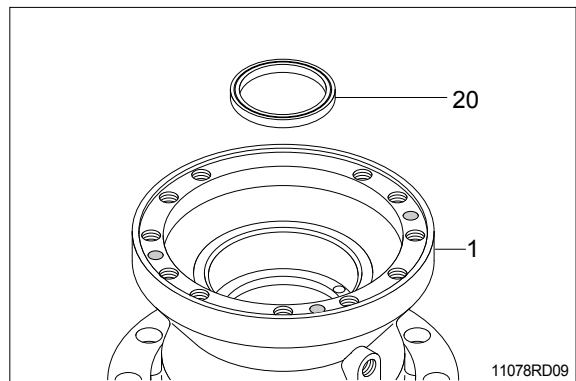

(15) Remove plugs(21, 22) from the casing(1).

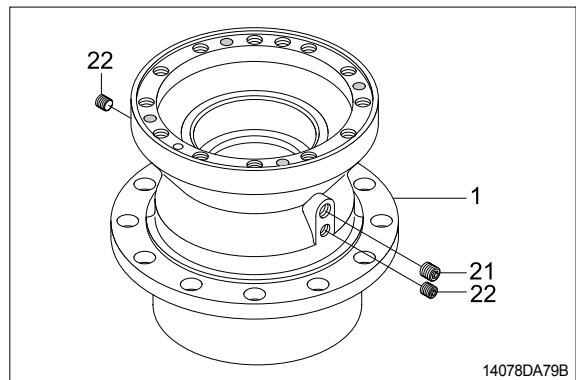

3) ASSEMBLY

- (1) Assemble the spacer(26), the cover plate(27) and the roller bearing(17) on the drive shaft(2).

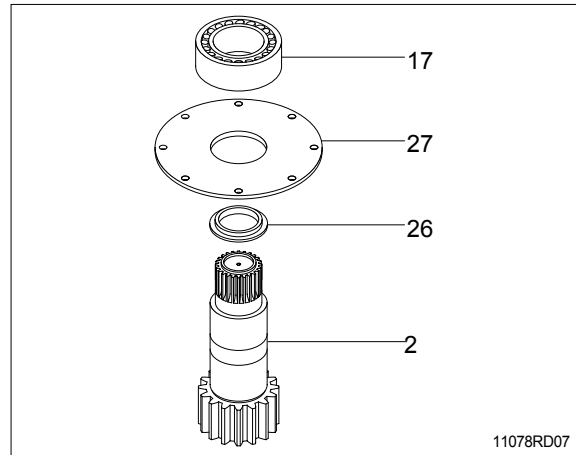

- (2) Assemble the drive shaft sub assembly(2) into the casing(1) and tighten the bolt(28) with loctite No.262.

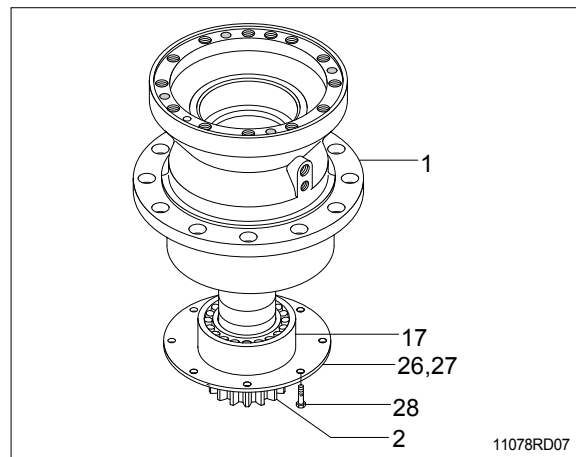

- (3) Install the oil seal(20) and the roller bearing(18).

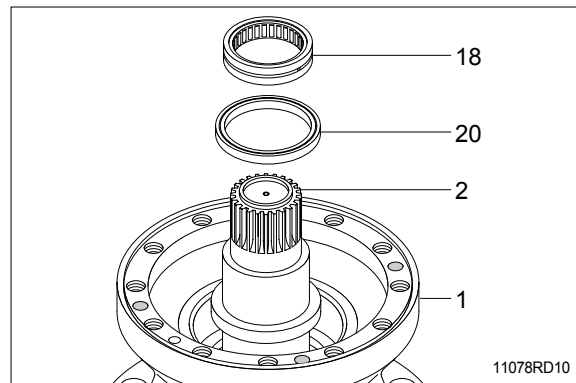

- (4) Install stop ring(25) on the drive shaft (2).

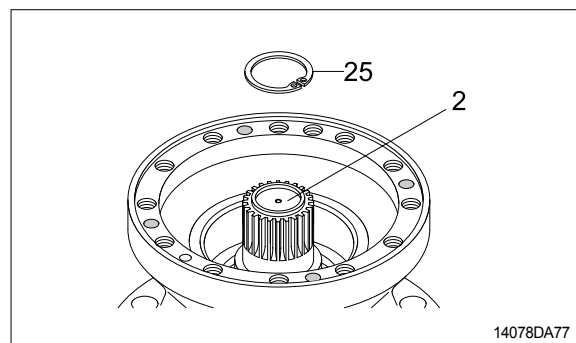

(5) Apply loctite to the tapped holes of casing (1).

(6) Tighten 2 M16 eye bolts to the ring gear(3) and lift up and then assemble it onto the casing(1).

※ Don't fail to coincide the knock pin(16) holes.

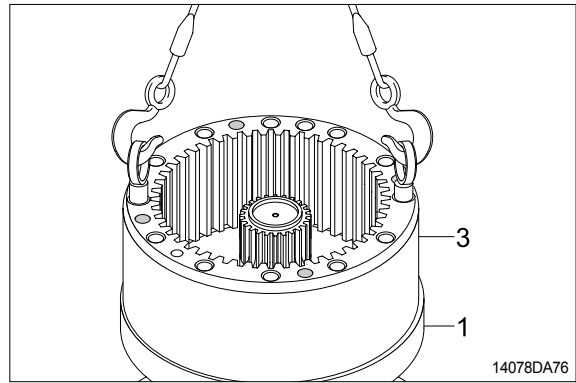

(7) Assembling carrier2(8) assembly.

① Install thrust washer(12) and the planet gear2(4) inside the carrier2(8).

② Assemble the pin2(10) to the carrier2(8) and then press the spring pin(23) by hammering.

③ Punch 2 points of the spring pin(23) lip.

※ Take care not to mistake the matching marks of each part.

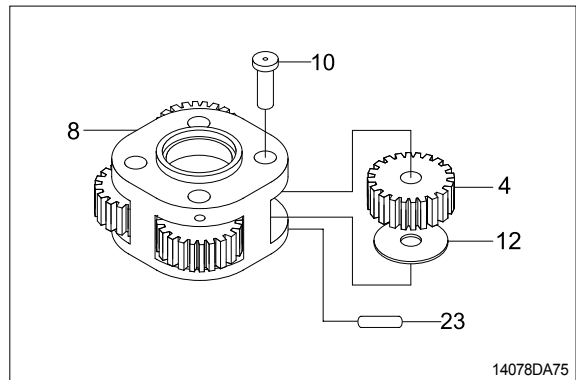

(8) Assemble carrier2(8) assembly correctly to the drive shaft(2).

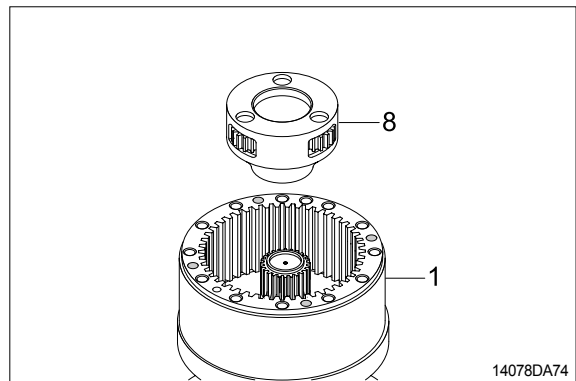

(9) Assemble sun gear2(5) and thrust gear (13) to the center of the carrier2(8) assembly.

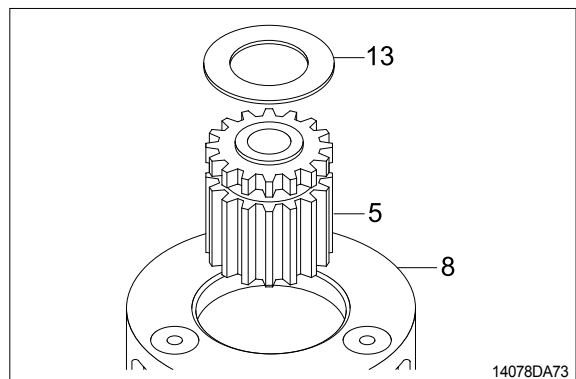

(10) Assembling carrier(9) assembly.

- ① Assemble the pin(11) to the carrier(9) and then press the spring pin(23) by hammering.
 - ② Punch 2 points of the spring pin's(23) lip.
 - ③ Install needle cage(29) into the planet gear(6).
 - ④ Assemble thrust washer(12), planet gear(6), and then stop ring(24) to the pin(11).
- ※ Take care not to mistake the matching marks of each part.

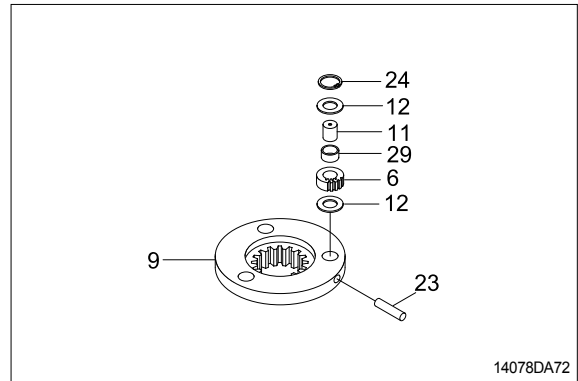

(11) Assemble carrier(9) assembly into the ring gear.

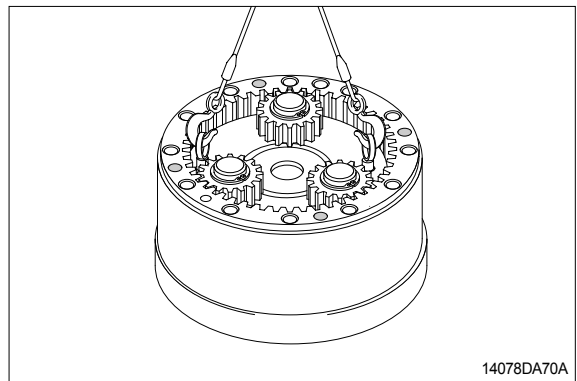

(12) Hammer 4 knock pins(16) around the ring gear(3).

(13) Assemble sun gear(7) and stop ring(24) to the drive shaft of the swing reduction gear.

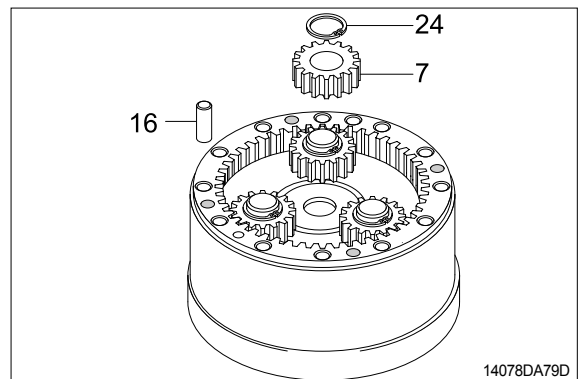

(14) Apply loctite to the tapped holes of the ring gear(3) and then mount swing motor onto the ring gear(3).

※ Don't fail to coincide the gauge bar(14) hole.

(15) Tighten socket bolts(19) around the swing motor assembly.

· Tightening torque : 24kgf · m(173lbf · ft)

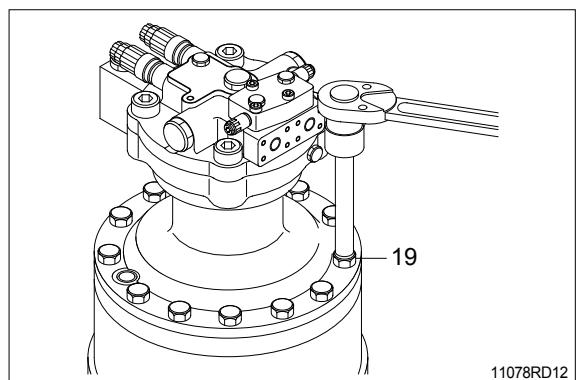

(16) Assemble plugs(21, 22), gauge bar(14) and gauge pipe(15).

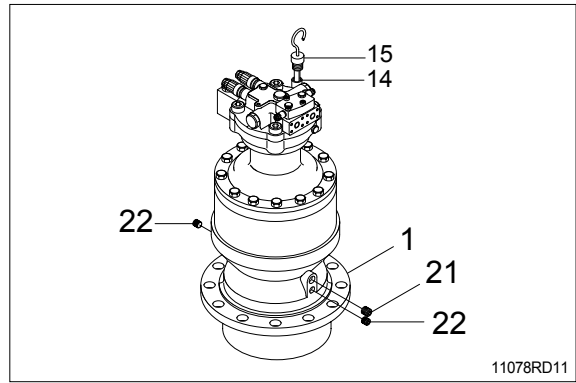

GROUP 6 TRAVEL DEVICE

1. REMOVAL AND INSTALL

1) REMOVAL

- (1) Swing the work equipment 90° and lower it completely to the ground.
- (2) Operate the control levers and pedals several times to release the remaining pressure in the hydraulic piping.
- (3) Loosen the breather slowly to release the pressure inside the hydraulic tank.

▲ Escaping fluid under pressure can penetrate the skin causing serious injury.

※ When pipes and hoses are disconnected, the oil inside the piping will flow out, so catch it in oil pan.

- (4) Remove the track shoe assembly.
For details, see **removal of track shoe assembly**.
- (5) Remove the cover.
- (6) Remove the hose.
※ Fit blind plugs to the disconnected hoses.
- (7) Remove the bolts and the sprocket.
- (8) Sling travel device assembly(1).
- (9) Remove the mounting bolts(2), then remove the travel device assembly.
· Weight : 165kg(240lb)



13031GE18

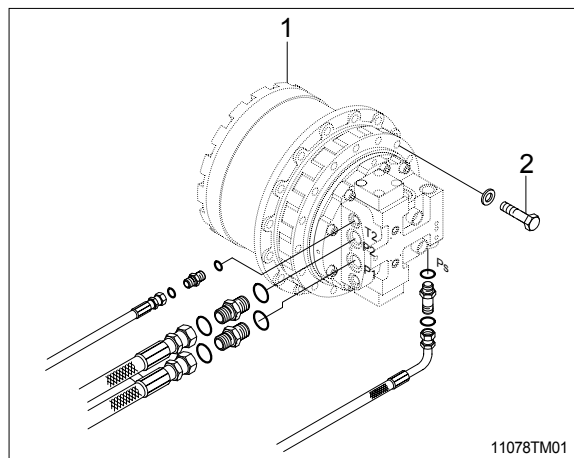

11078TM01

2) INSTALL

- (1) Carry out installation in the reverse order to removal.
- (2) Bleed the air from the travel motor.
 - ① Remove the air vent plug.
 - ② Pour in hydraulic oil until it overflows from the port.
 - ③ Tighten plug lightly.
 - ④ Start the engine, run at low idling, and check oil come out from plug.
 - ⑤ Tighten plug fully.
- (3) Confirm the hydraulic oil level and check the hydraulic oil leak or not.

2. TRAVEL MOTOR

2) STRUCTURE

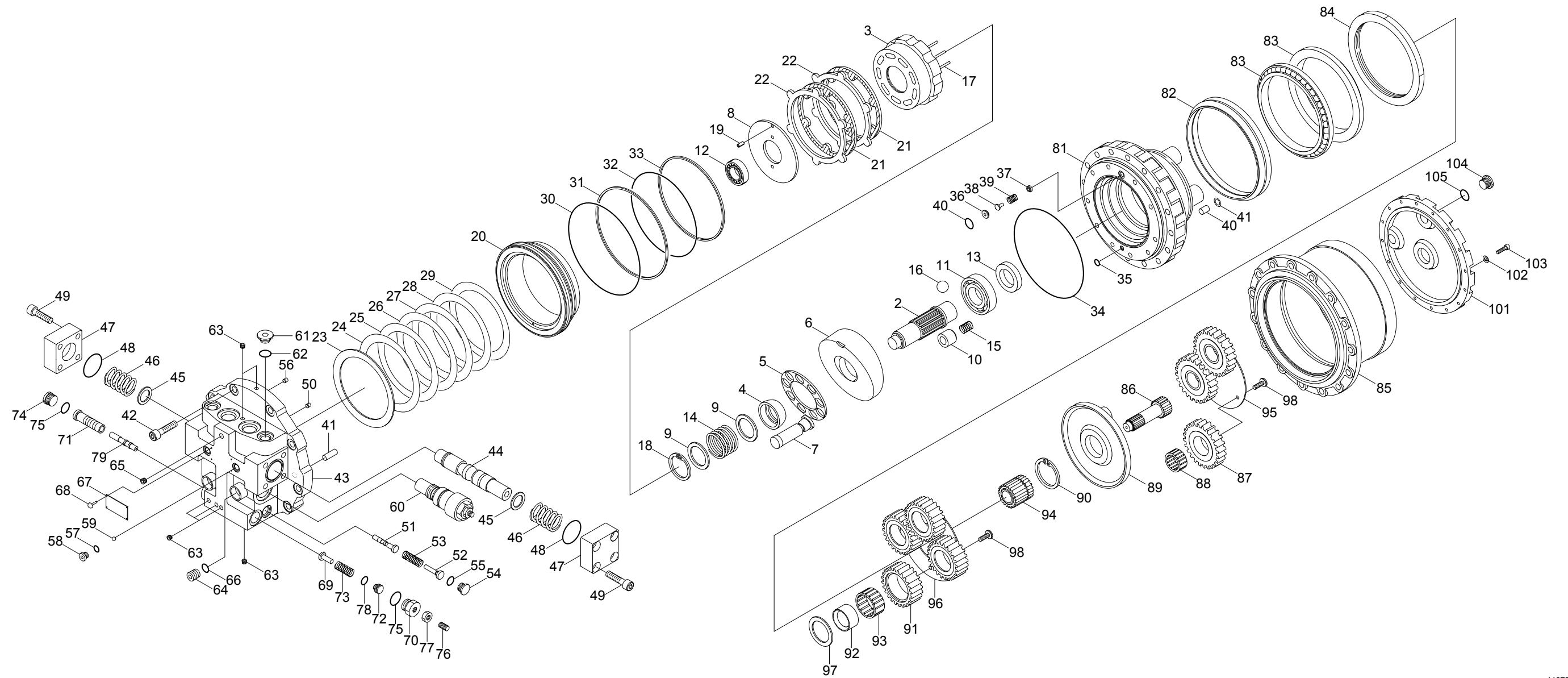

2	Shaft	20	Brake piston	37	Retainer	54	Plug	71	Sleeve	89	Carrier
3	Cylinder barrel	21	Friction plate	38	Poppet	55	O-ring	72	Stopper	90	Sun gear B
4	Ball retainer	22	Steel plate	39	Spring	56	Orifice	73	Spring	91	Planetary gear B
5	Retainer	23	Disk spring	40	O-ring	57	Steel ball	74	Plug	92	Bushing
6	Cam	24	Shim(1.0T)	41	Pin	58	Plug	75	O-ring	93	Needle bearing B
7	Piston assembly	25	Shim(1.2T)	42	Bolt	59	O-ring	76	Screw	94	Snap ring
8	Valve plate	26	Shim(1.4T)	43	Motor cover assembly	60	Relief valve assembly	77	Nut	95	Thrust plate(2)
9	Plate	27	Shim(1.6T)	44	Spool assembly	61	Plug	78	O-ring	96	Thrust plate(3)
10	Piston assembly	28	Shim(1.8T)	45	Washer	62	O-ring	79	Rod	97	Thrust plate(4)
11	Ball bearing	29	Shim(2.0T)	46	Spring	63	Plug	81	Casing body	98	Screw
12	Roller bearing	30	O-ring	47	Cover	64	Plug	82	Floating seal	99	Washer
13	Oil seal	31	Back up ring	48	O-ring	65	Plug	83	Angular bearing	100	Parallel pin
14	Spring	32	O-ring	49	Bolt	66	O-ring	84	Ring nut	101	Cover
15	Spring	33	Back up ring	50	Orifice	67	Name plate	85	Casing gear	102	Spring washer
16	Steel ball	34	O-ring	51	Spool	68	Rivet	86	Sun gear A	103	Bolt
17	Pin	35	O-ring	52	Stopper	69	Spring guide	87	Planetary gear A	104	Plug
18	Snap ring	36	Seat	53	Spring	70	Plug	88	Needle bearing A	105	O-ring
19	Spring pin										

11072TM04

2) TOOLS AND TIGHTENING TORQUE

(1) Tools

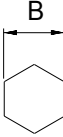
Tool name		Remark	
Allen wrench		5, 6, 8, 10, 14	
OSocket for socket wrench, spanner	Socket	22, 30, 32, 41	
	Rod	5, 6, 8, 10, 14, 19	
Torque wrench		Capable of tightening with the specified torques	
Pliers		-	
(-) Driver		150mm	
Plastic and iron hammer		Wooden hammer allowed. Normal 1 or so	
Steel rod approx		7×7×200mm	
Monkey wrench		-	
Oil seal inserting jig		-	
Bearing pliers		-	
Seal tape		-	
Eye bolt		PF1/2, M16	
Press(0.5 ton)		-	
Oil stone		-	
Bearing assembling jig		-	
Liquid packing		Loctite #577	
Screw lock		Loctite #243	

(2) Tightening torque

Part name	Item	Size	Torque	
			kgf · m	lbf · ft
Screw	98	M10	7.0±0.5	50.6±3.6
Bolt	103	M8	3.6±0.2	26.0±1.4
Plug	104	PF3/4	10.0±1.0	72.3±7.2
Bolt	42	M14	19.5±1.5	141.0±10.8
Orifice	43	NPTF1/16	1.0±0.1	7.2±0.7
Plug	44	M20	8.6±0.8	62.2±5.8
Bolt	49	M12	8.0±0.8	57.9±5.8
Orifice	50	NPTF1/16	1.0±0.1	7.2±0.7
Plug	54	PF3/8	5.0±0.5	36.2±3.6
Orifice	56	NPTF1/16	1.0±0.1	7.2±0.7
Plug	58	PF1/8	2.0±0.2	14.5±1.4
Relief valve body	60-1	M28	20.0±2.0	144.7±14.5
Cap nut	60-7	M38	20.0±2.0	144.7±14.5
Screw	60-10	M10	3.5±0.2	25.3±1.4
Plug	61	3/4-16UNF	7.0±0.5	50.6±3.6
Plug	63	NPTF1/16	1.0±0.1	7.2±0.7
Plug	64	9/16-18UNF	5.0±0.5	36.2±3.6
Plug	65	PT1/8	2.0±0.2	14.5±1.4
Plug	70	7/8-14UNF	8.0±0.8	57.9±5.8
Plug	74	7/8-14UNF	8.0±0.8	57.9±5.8
Screw	76	M10	3.5±0.2	25.3±1.4

3. DISASSEMBLY

1) GENERAL PRECAUTIONS

- (1) Before disassembling the motor, check the items to be inspected and, for remedy against trouble, closely examine the nature of the trouble, so that the motor can be disassembled effectively.
- (2) To disassemble the motor, use the disassembling procedures described in section 2) and select a clean place.
- (3) Place a rubber or vinyl sheet or other such protective materials on your working bench to protect the surface of the motor to be serviced.
- (4) During disassembly, give a match mark to the mating surfaces of each part.
- (5) Arrange removed parts in order so that they will not become damaged or missing during disassembly.
- (6) Once seals have been disassembled, they should be replaced even if damage is not observed. Have replacement seals ready on hand before starting your disassembling job.

2) DISASSEMBLING PROCEDURE

- (1) Clean the outside of the travel motor completely before disassembling.

Be aware that in re-assembling, the parts must be installed in the original locations.

For this purpose, it is strongly recommended to record the original positions of the parts before and during disassembling process.

- (2) Remove the drain plug and drain the lubricating oil. The capacity of the travel motor is 2.5 liters (0.55U.K.gal; 0.66U.S.gal). Place the travel motor on the flat clean ground.

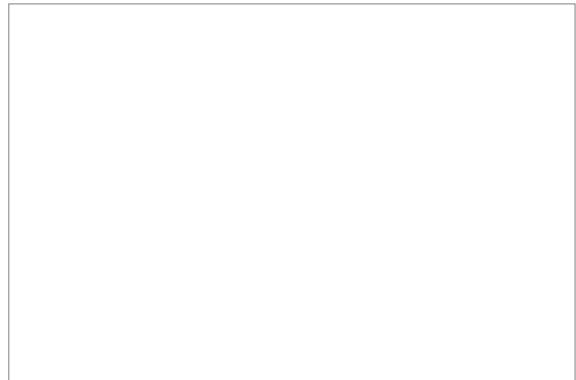

- (3) Remove one relief valve(1) shown in the picture.

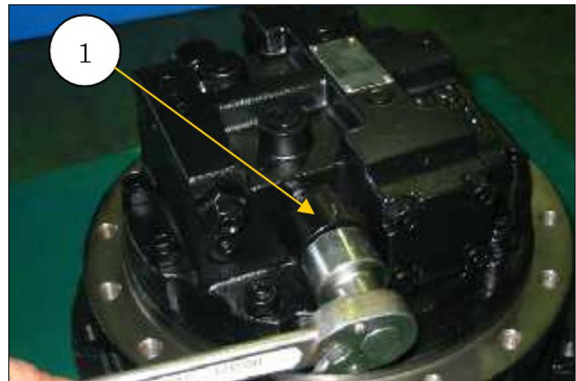

11078TM12

- (4) Remove ten bolts(2) and motor cover(3).
※ Removing the relief valve(1) first makes it easier to remove ten bolts(2) and brake valve(3) later as shown.

▲ Be careful not to drop a valve plate. Don't give damage to it. It is on the motor cover inside surface.

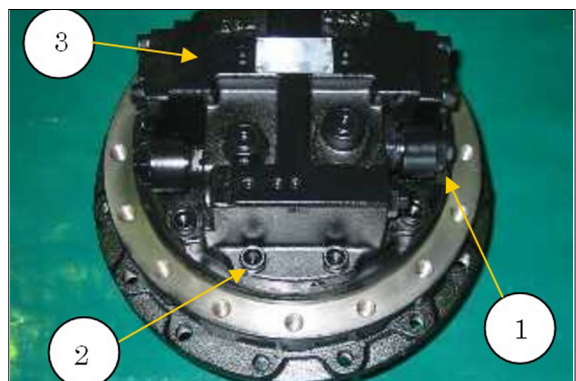

11078TM11

- ※ It would be easier to remove motor cover if you temporarily replace two bolts with two "tool" bolts(4) of yours as shown.
(You don't have to use them necessarily).
- Bolt thread size = M12 × P1.75
 - Bolt length = about 70mm(for example)



11078TM13

- (5) Place brake valve(3) on wood blocks(5) as shown.

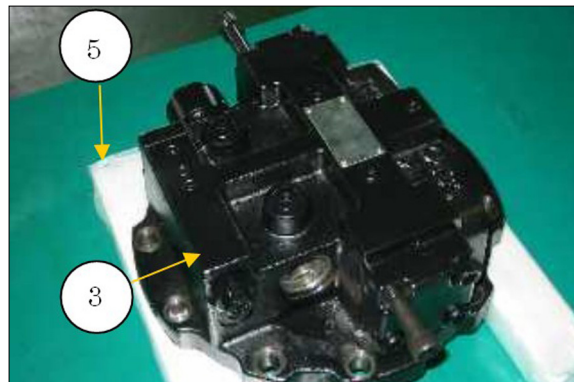

11078TM14

- (6) Remove back-up ring(6) and O-ring(7) from the relief valve(1).



11078TM15

(7) Remove two diagonal bolts(8) on one side as shown. Then, loosen the two remaining bolts little by little alternately until they are removed completely. Remove cover(9) from the brake valve.

▲ There is strong spring pressure under the cover(9). For your safety and preventing damage, be sure to loosen the bolts carefully so that spring pressure is under your control. Follow the procedure below.

※ If it is difficult to pull out the spool assembly(12) because of vacuum action, it will be easier by loosening another 4 bolts(8) and cover(9) on the other side a little. (Face distance 0.5mm is enough)

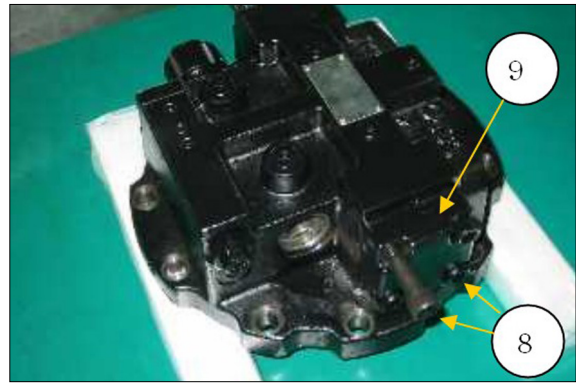

11078TM16

(8) Remove spring(10), washer(11) and spool assembly(12) from the brake valve. They are located behind the cover(9).

※ Don't disassemble spool assembly(12). The component(12) should be serviced only as an assembly.

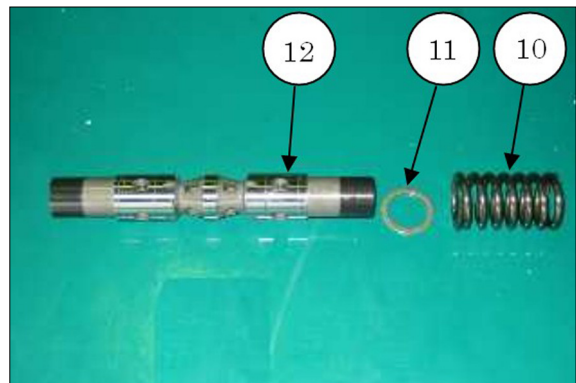

11078TM17

(9) Remove O-ring(13) and plug(14) from the brake valve. Remove the O-ring from plug(14).

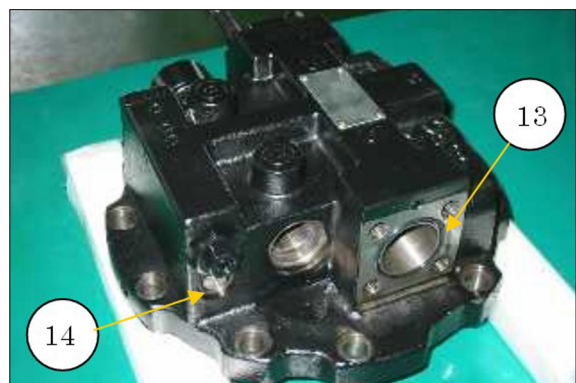

11078TM18

(10) Remove stopper(15), spring(16), and spool(17) located behind plug(14), from the brake valve.

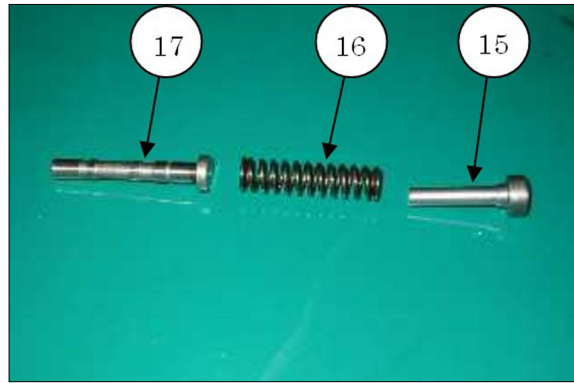

11078TM19

(11) Remove two plugs(18).

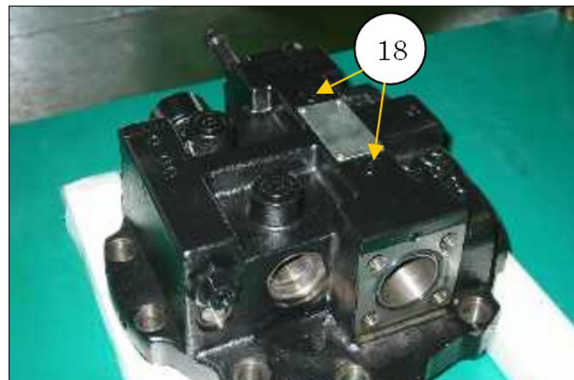

11078TM20

(12) Remove O-ring(19) from each plug.
Remove steel balls(20) from the brake valve.

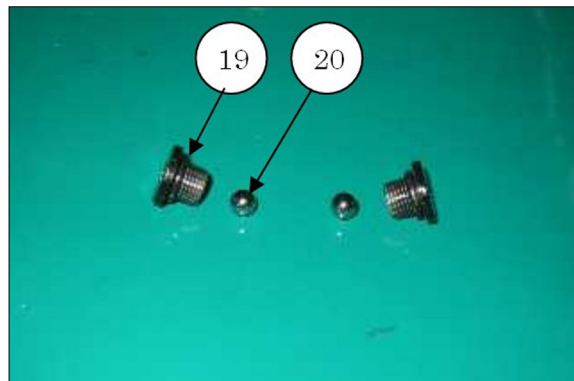

11078TM21

(13) Remove one relief valve(21) shown in the picture.



11078TM22

(14) Remove back-up ring(22) and O-ring(23) from the relief valve.



11078TM23

(15) Remove plug assembly(24) from the brake valve.

- ※ Don't disassemble plug assembly(24). The screw setting must be kept at the original condition.

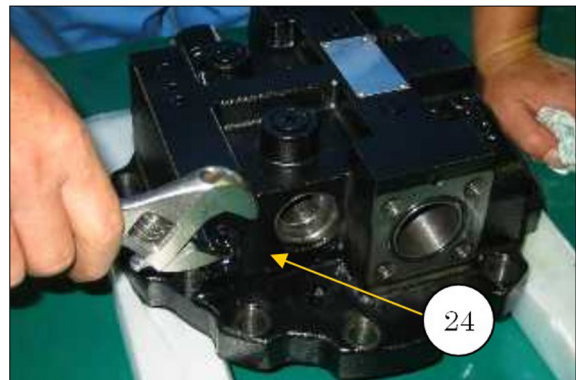

11078TM24

(16) Remove plug(25).

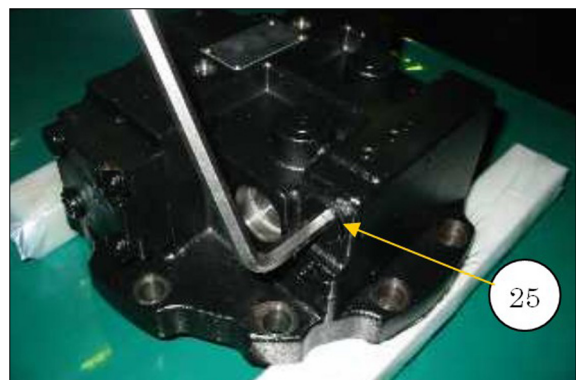

11078TM25

(17) Remove spring(26), spring guide(27) and rod(28) behind plug assembly(24). Remove the O-ring(29) from plug assembly(24). Remove the O-ring(30) from plug(25).

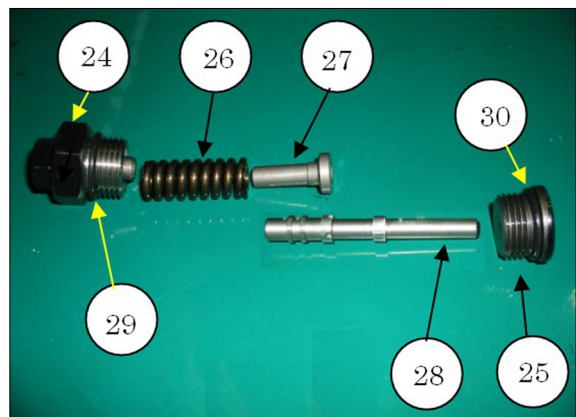

11078TM26

- ※ You don't have to remove sleeve inside the brake valve if the speed-shifting is functioning in order.

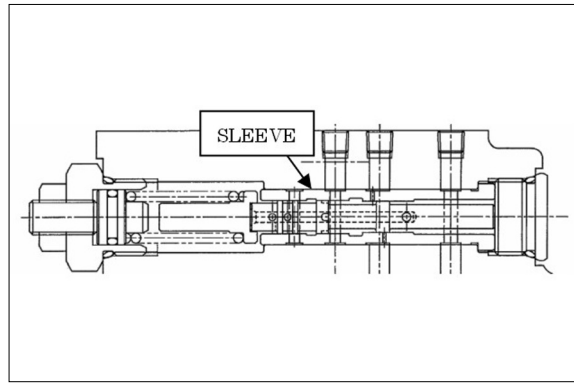

11078TM27

- (18) Remove four bolts(31) and remove cover (32). Refer to step 7.

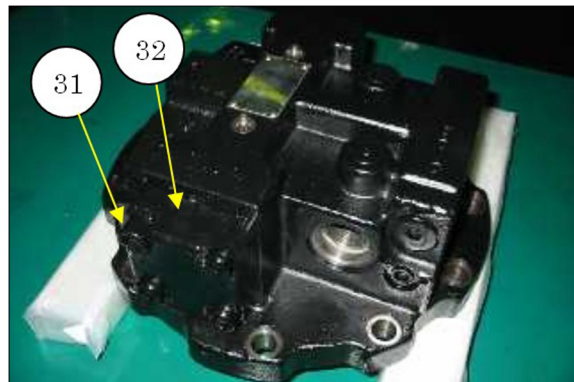

11078TM28

- (19) Place the brake valve upside-down as shown. Remove valve plate(33) from the brake valve.



11078TM29

- (20) If necessary, remove bearing(34) and location pin(35).

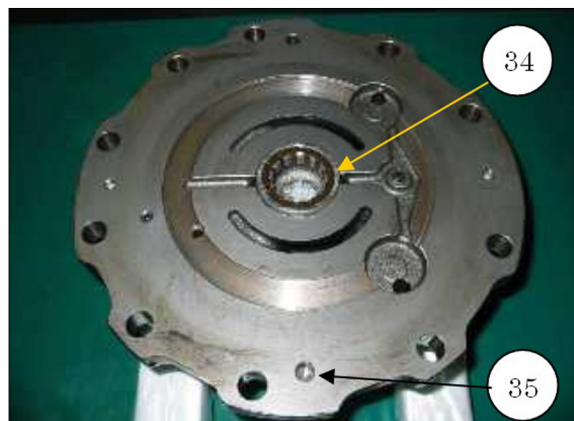

11078TM30

(21) Remove three O-rings(36)(37)(38), two disk springs(39), and shim(40) from the body casing.

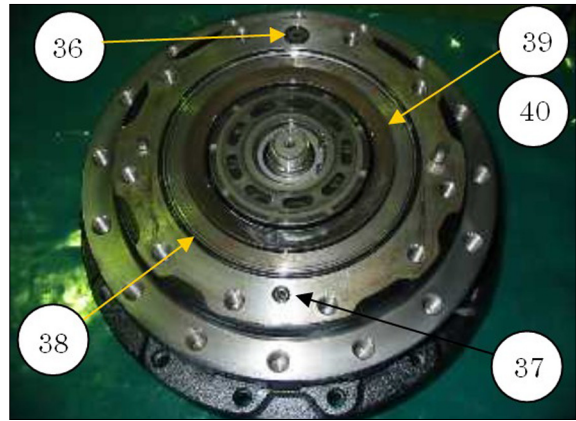

(22) Install tooling "Brake piston puller" as shown.

- Screw-in two bolts to the brake piston.
- Turn the center bolt little by little and let the center bolt push the shaft. Then the brake piston comes out.
- Remove brake piston(41).

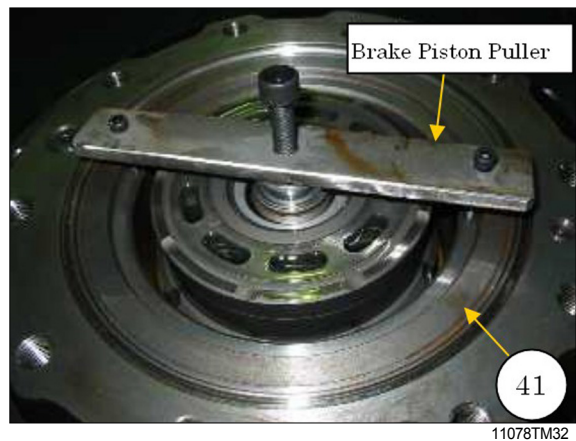

(23) Remove O-rings(42)(43) and back-up rings(44)(45) from the brake piston.

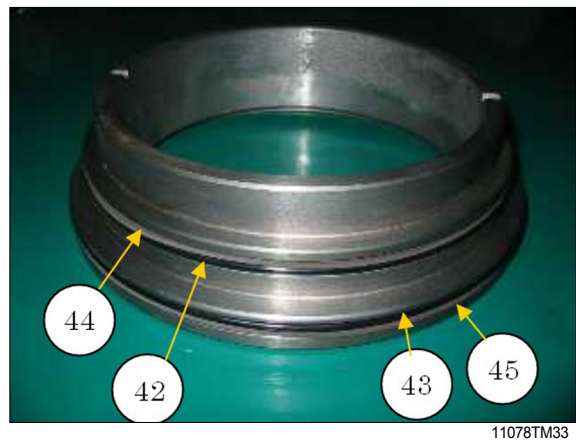

(24) Remove two friction plates(46) and two steel plates(47) from the body casing, using a steel wire, a magnet, etc. Don't pull off the cylinder barrel component yet.



11078TM34



11078TM35

(25) Position the travel motor as shown on a wood block and apply wood wedges that prevent the travel drive from rolling around. Remove cylinder barrel assembly (48) from the body casing.

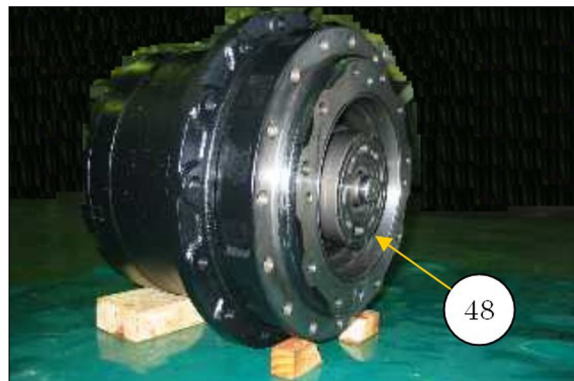

11078TM36



11078TM37

(26) Be aware that in re-assembling, retainer(49), piston assemblies(50) and cylinder barrel(51) must be installed in the original locations.

For this purpose, it is strongly recommended to record the original positions of the parts before and during disassembling process.

(27) Remove retainer(49) and piston assemblies(50) from barrel(51). Separate the piston assemblies from the retainer.

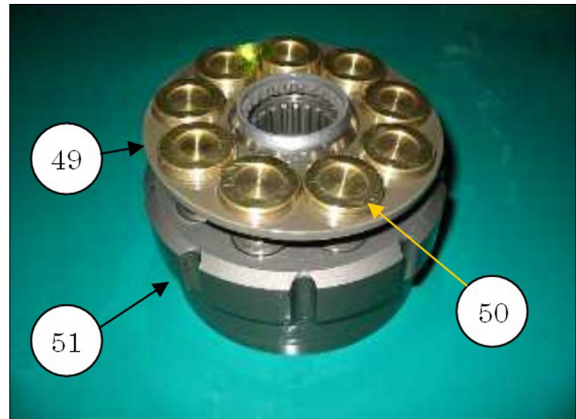

(28) Remove retainer ball(52) from the cylinder barrel.



(29) Remove three pins(53) from the cylinder barrel.



(30) Give a slight amount of compression on plate(54) with a press machine using a suitable size diameter jig.

Remove snap ring(55). Remove plate(54) spring(56) and plate(57) from the cylinder barrel(51).

▲ There is strong spring force behind plate (54). For your safety and avoid-ing damage, a press machine should be used to hold spring compression in disassembling the internal components in cylinder barrel.



11078TM41

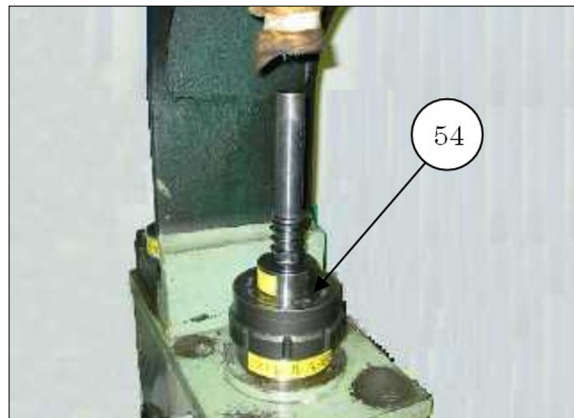

11078TM42



11078TM43

(31) Remove cam(58) from the body casing.

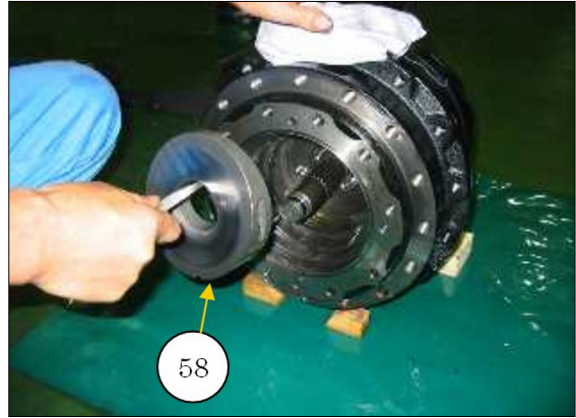

11078TM44

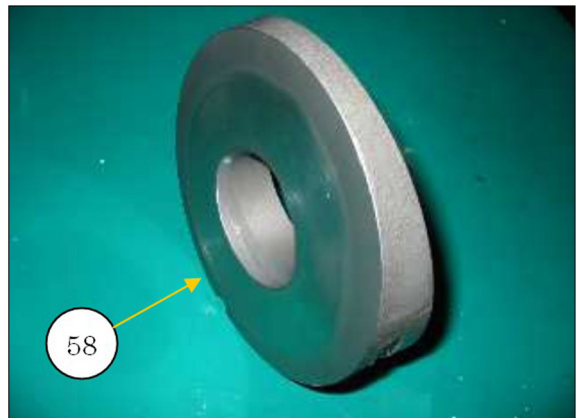

11078TM45

(32) Remove two steel balls(59) and piston(60) from the body casing. Remove the spring(61) behind the piston.

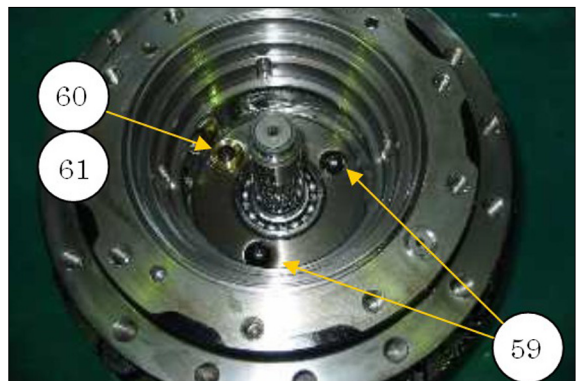

11078TM46



11078TM47

(33) Place the travel motor on wood blocks as shown. Remove sixteen bolts(62) and washers(63).

⚠ To avoid damaging shaft, don't put the travel motor directly on a flat ground but use blocks.

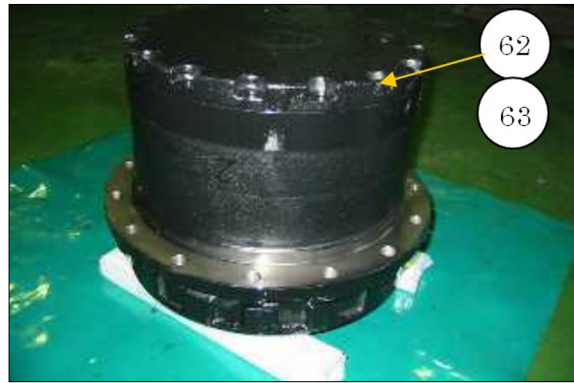

11078TM48

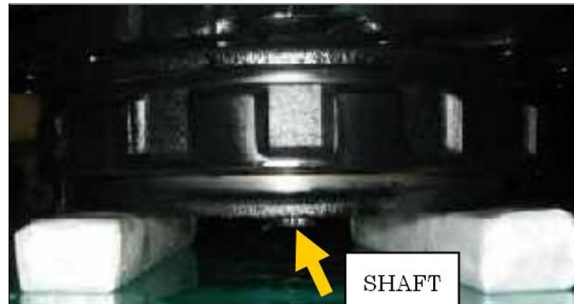

11078TM49

(34) With a soft-faced hammer, break the seal between cover(64) and gear casing(65). Remove the cover(64).



11078TM50



11078TM51

(35) Remove three bolts(66) and a thrust plate(67).

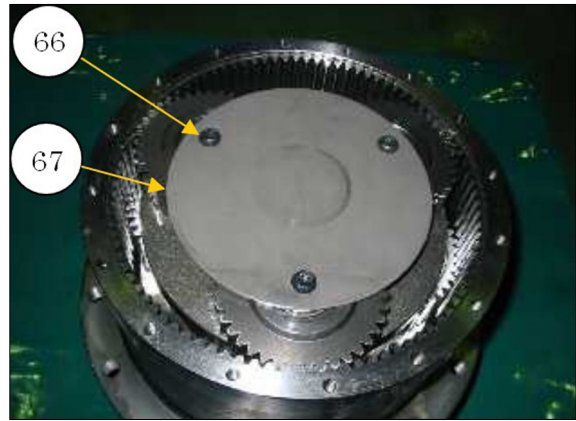

11078TM52

(36) Remove sun gear(68), three planetary gears(69) and three bearings(70).

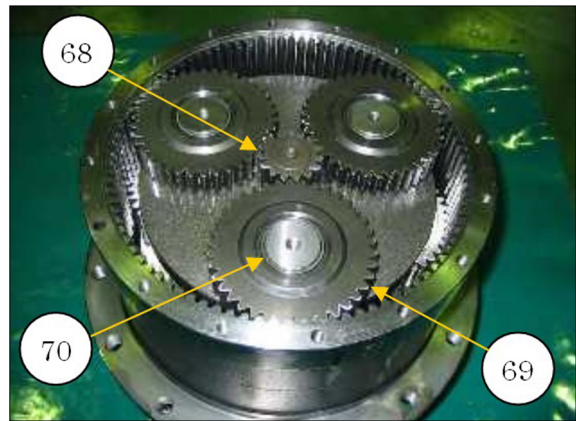

11078TM53

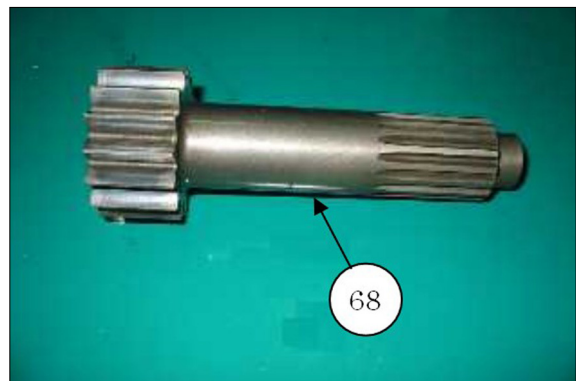

11078TM54

(37) Remove carrier(71).



11078TM55

(38) If necessary, remove three inner races(72) from the carrier shaft.

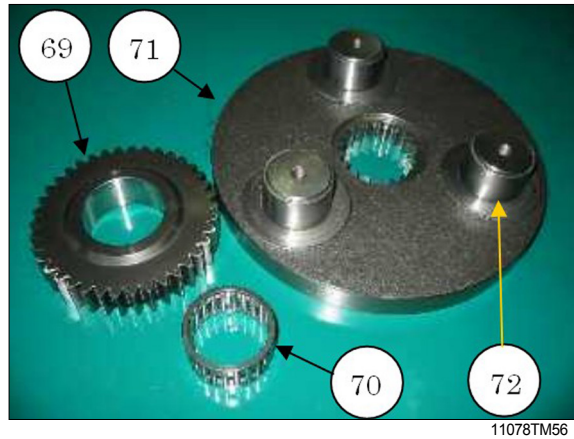

(39) Remove sun gear(73).

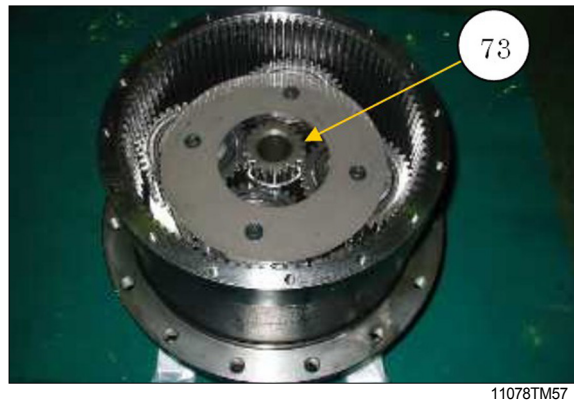

(40) Remove snap ring(74) from sun gear(73).

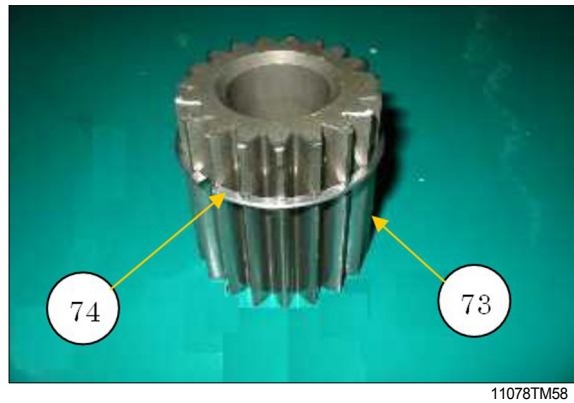

(41) Remove four bolts(75) and a thrust plate (76).

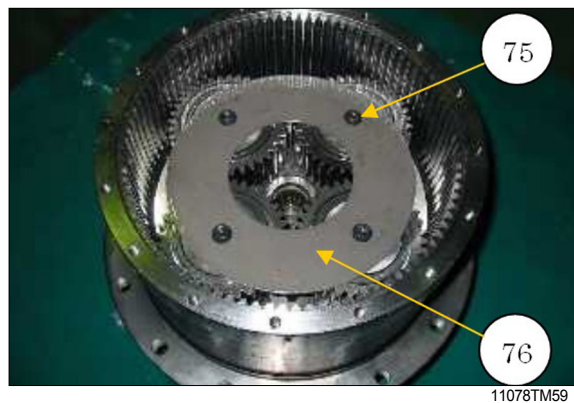

(42) Remove four planetary gears(77), four bearings(78), four bushes(79) and four plates(80).

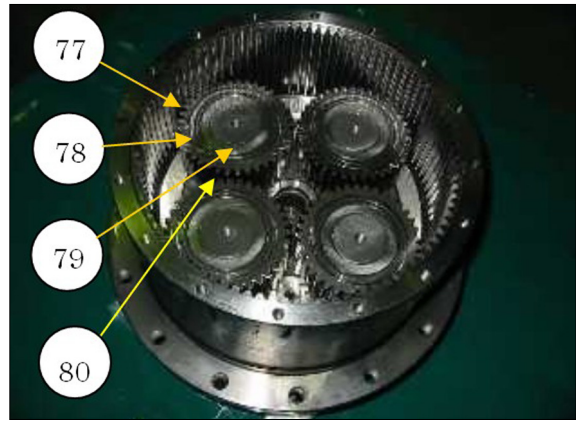

11078TM60

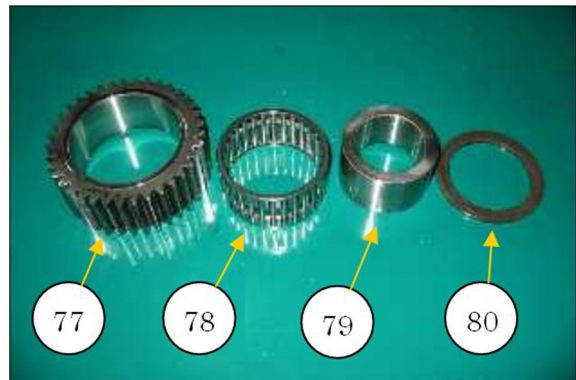

11078TM61

(43) Remove bolt(81) and washer(82).

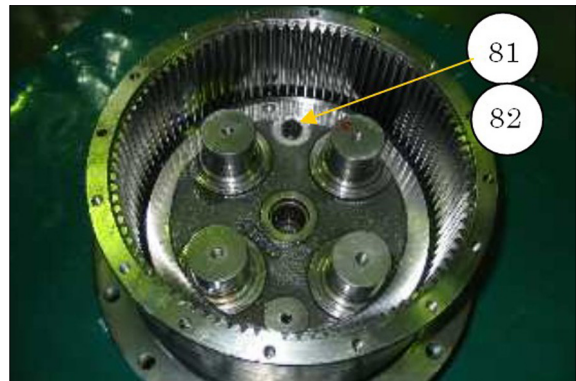

11078TM62

(44) Remove pin(83) with a magnet.
If it is difficult, follow the procedure below.
① Put a cover plate over the tap hole as shown.
② Drill a hole to the pin(83).
③ Drill a tap to the hole in the pin(83).
④ Screw-in a bolt to some degree and pull off the pin with the bolt.

(45) Remove ring nut(84) from the body casing.

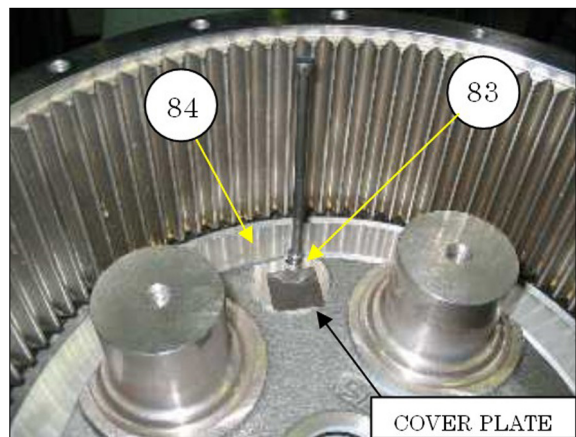

11078TM63

(46) Remove the gear casing(65) from the body casing with a hoist.

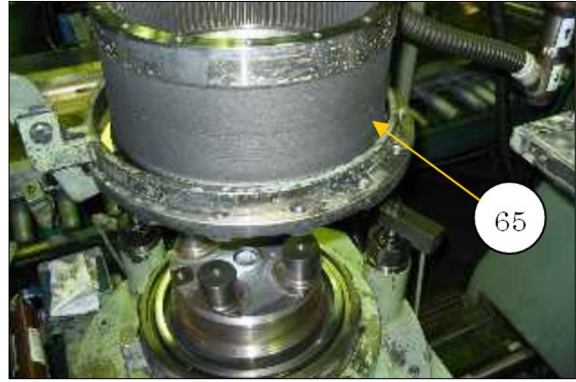

(47) Remove an angular bearing(85) from the gear casing.



(48) Put the gear casing upside-down. Remove a floating seal(86) and another angular bearing(87) from the gear casing.

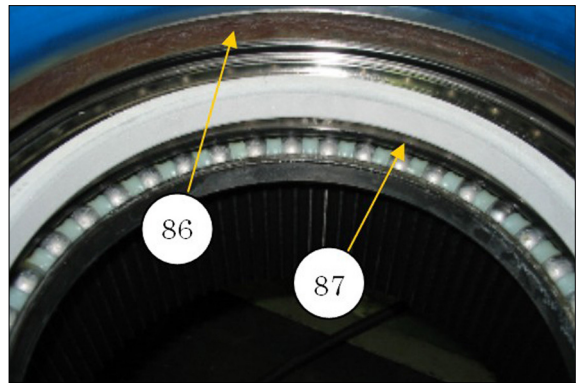

(49) Remove another floating seal(88) from body casing(89). Remove shaft(90) and bearing(91) from the body casing by giving force as shown with an arrow in the picture using a soft-faced hammer and a proper jig. Sometimes, bearing(91) may remain in the body casing. In this case, remove the bearing(91) as shown in the step 50.

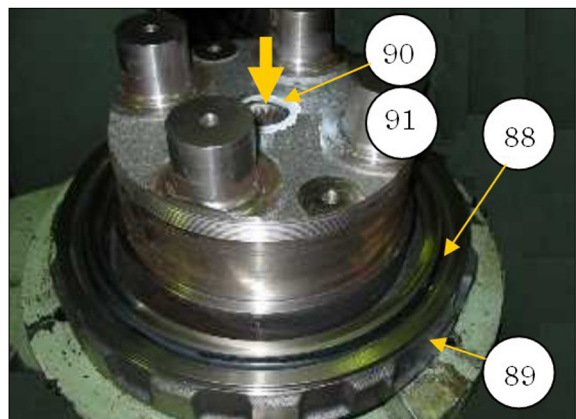

(50) If necessary, remove a bearing(91) from the body casing.
Remove an oil seal(92) from the body casing.



11078TM68

(51) If necessary, remove a bearing(91) from the shaft(90). If necessary, remove an inner race(93) from the shaft(90).

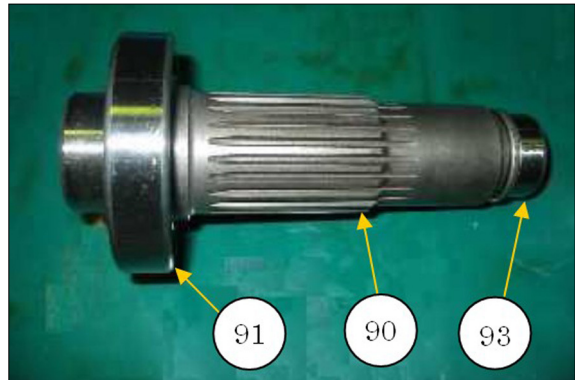

11078TM69

This is the end of disassembling process.

4. ASSEMBLY

1) GENERAL PRECAUTIONS

- (1) Reassemble in a work area that is clean and free from dust and grit.
- (2) Handle parts with bare hands to keep them free of linty contaminants.
- (3) Repair or replace the damaged parts.
Each part must be free of burrs at its corners.
- (4) Do not reuse O-rings, oil seal and floating seal that were removed in disassembly.
Provide the new parts.
- (5) Wash all parts thoroughly in a suitable solvent.
Dry thoroughly with compressed air.
Do not use the cloths.
- (6) When reassembling oil motor components of motor, be sure to coat the sliding parts of the motor and valve with fresh hydraulic oil. (NAS class 9 or above)
- (7) Use a torque wrench to tighten bolts and plugs, to the torque specified as follows.

2) ASSEMBLING PROCEDURE

- (1) Make sure that all the parts are completely clean and free of dirt and debris before assembling.

Check the condition of all O-rings, back-up rings, and oil seal used in the travel motor. If any of them have any damage, replace them with new ones.

Put the body casing on a clean sheet spread on the flat base.

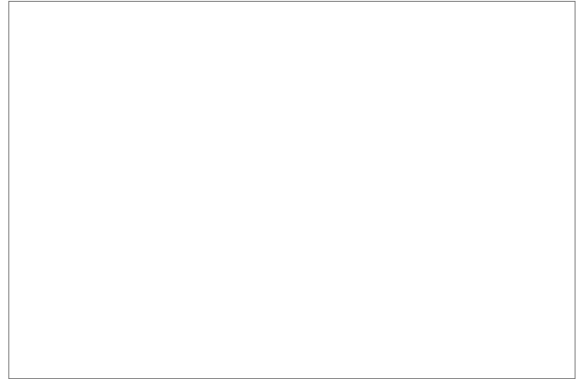

- (2) Install oil seal to body casing.
Put bearing(91) and inner race(93) on shaft(90).
Install shaft(90) into the body casing.

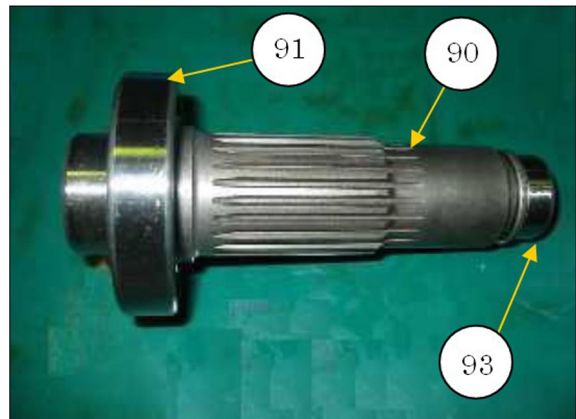

11078TM70

- ※ Before installing floating seals, make the O-ring(=rubber) and seal ring(=metal) clean and dry.
After installing the seals, put clean SAE30 engine oil or gear oil 80W-90 on the contact surfaces of the metal seals.

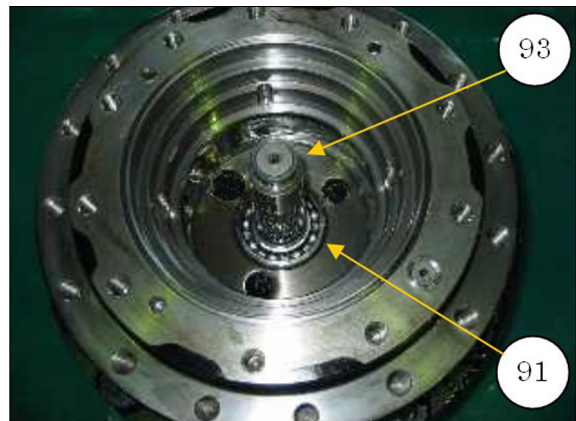

11078TM71

- (3) Place the body casing on wood blocks or other proper jigs with the shaft side down.

- ▲ **To avoid damaging shaft, don't put the body casing directly on a flat ground.**



11078TM72

- (4) Install floating seal(88) in the body casing, using tool "Floating seal installer". Then, put clean SAE30 engine oil or gear oil 80W-90 on the contact surface(flat surface) of the metal seal.



11078TM73

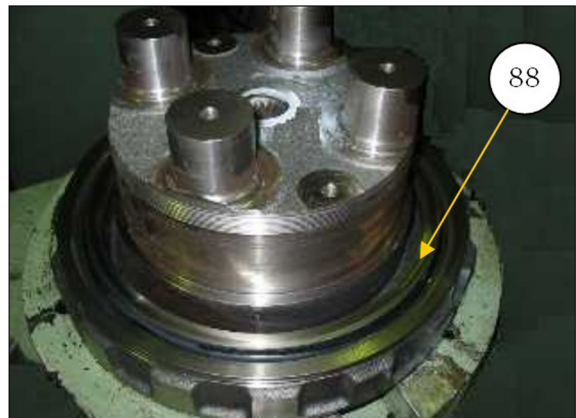

11078TM74

- (5) Install an angular bearing(85) to the gear casing.

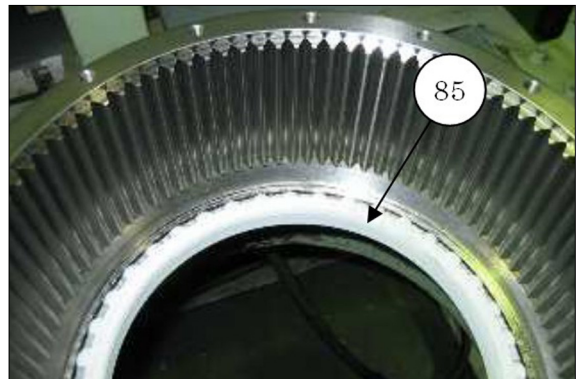

11078TM75

- (6) Put the gear casing upside-down as shown. Install another angular bearing(87) to the gear casing.
- ※ Before installing floating seals, make the O-ring(=rubber) and seal ring(=metal) clean and dry.
- After the installation of the seals, put clean SAE30 engine oil or gear oil 80W-90 on the contact surfaces of the metal seals.

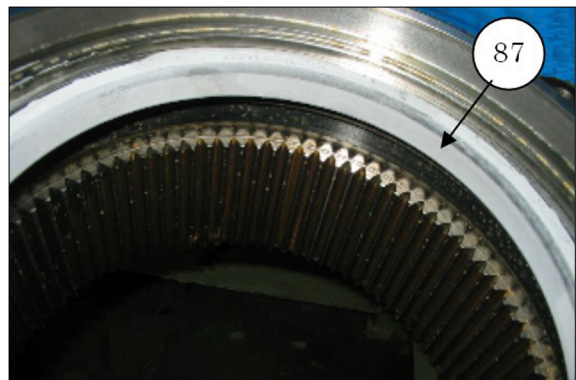

11078TM76

(7) Install another floating seal(86) in the gear casing, using tooling "Floating seal installer".

Then, put clean SAE30 engine oil or gear oil 80W-90 on the contact surface(flat surface) of the metal seal.

※ Be careful and don't scratch or damage the floating seals before and during assembling the two components.

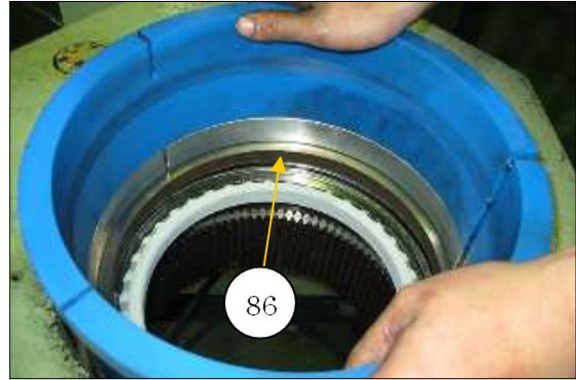

11078TM77

(8) Hoist a gear casing(65) over the body casing(89) as shown. Install the gear casing on the body casing(89).

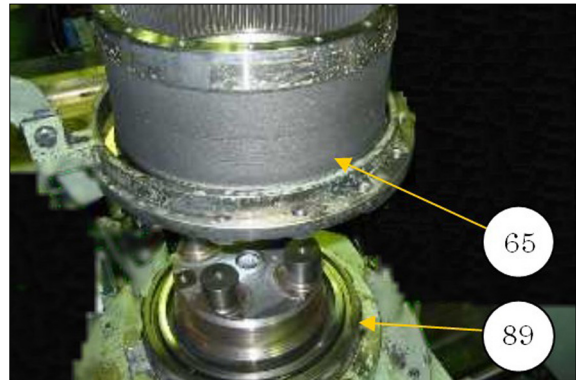

11078TM78

※ After installing the ring gear on the body casing, there will be a gap between two components. This is a normal phenomenon caused by the floating seals, and the gap will be eliminated by installing the ring nut(84).

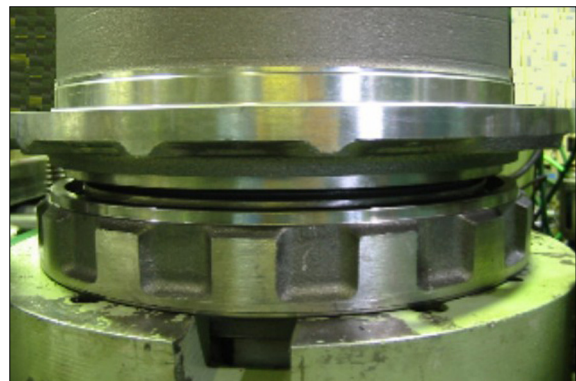

11078TM79

(9) Use the following procedure to make a preload adjustment of bearings(85) and (87) as follows :

- a. Tighten the ring nut(84) strongly enough until there is no gap among body casing, two bearings, gear casing, and ring nut.
- b. Rotate gear casing(65) several turns.
- c. Turn the ring nut(84) forward/backward and adjust the tightening position of the ring nut(84) until the pull-force of spring scale to the tangent-line direction while turning(as shown below) is **216~294N (48.5~66.1lbf)**.

※ To apply a pin to the ring nut, a new hole should be drilled at the opposite position from the original position. It is because that the rotating position of ring nut is not necessarily the same as the original position when it is adjusted by the procedure (9).

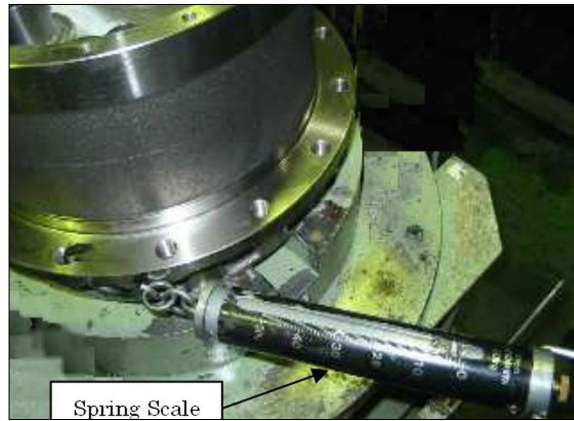

11078TM80

(10) Put a cover plate over the tap hole. Drill a new hole between body casing and ring nut as shown.

Drill hole spec :

- Drill hole diameter = $\varnothing 8.00 \sim \varnothing 8.15\text{mm}$
- Drill hole depth = 11.0~11.5mm

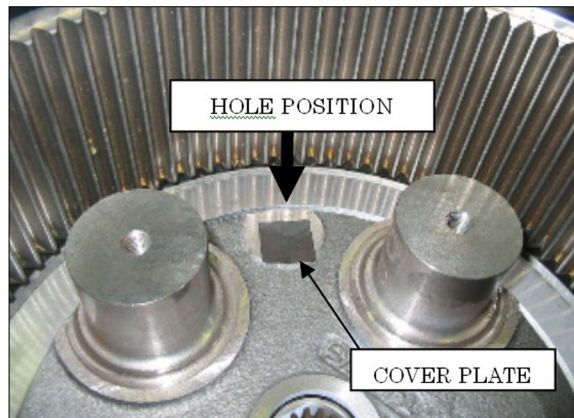

11078TM81

(11) Take away all the debris caused by drilling. Install pin(83) in a newly drilled hole between body casing(89) and ring nut(84).

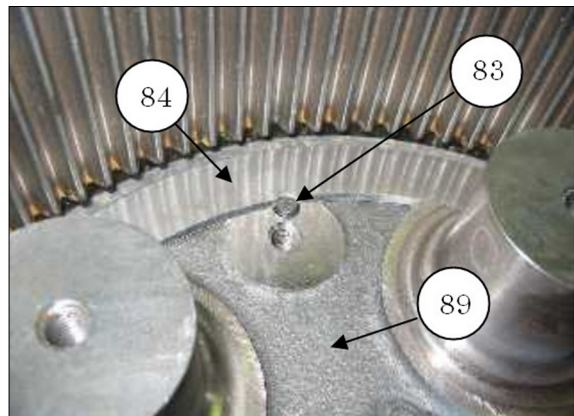

11078TM82

- (12) Apply **Thread Lock "THREE BOND 2403"** to bolt(81). Install bolt(81) and washer(82) to the body casing. Tighten the bolt to a torque of 68.6 ± 4.9 N·m(50.6 ± 3.6 lbf·ft).

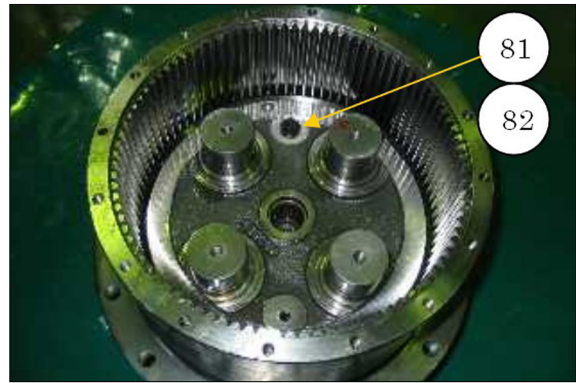

11078TM83

- (13) Position the travel motor as shown. Install two steel balls(59), spring(61) and piston assembly(60) in the body casing.

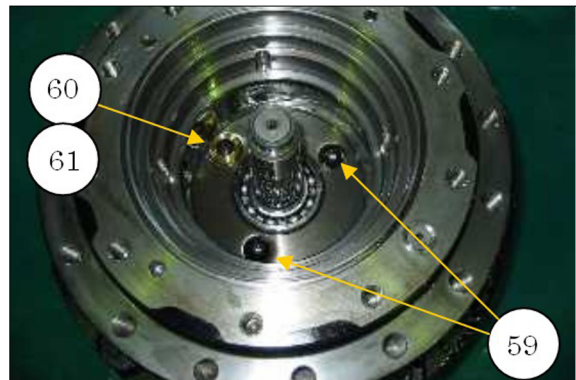

11078TM84

- (14) Install cam(58) in the travel motor body. By pushing the cam several times, confirm that the cam action is smooth.



11078TM85

- (15) Install plate(57), spring(56) and plate(54) in cylinder barrel(51).
Use a press machine on plate(54), and compress spring(56).
Install snap ring(55).

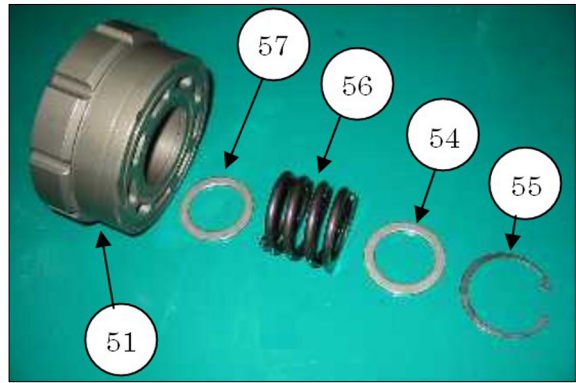

11078TM86

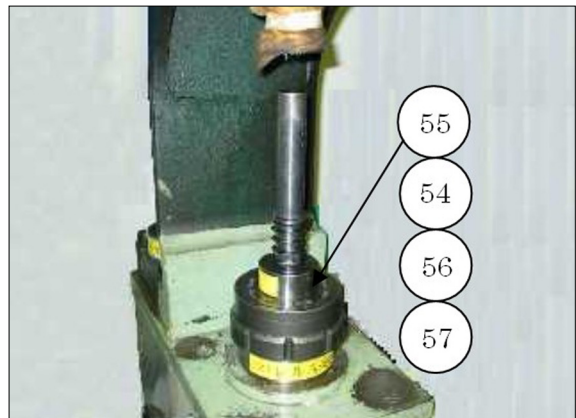

11078TM86

- (16) Install three pins(53) in the cylinder barrel.

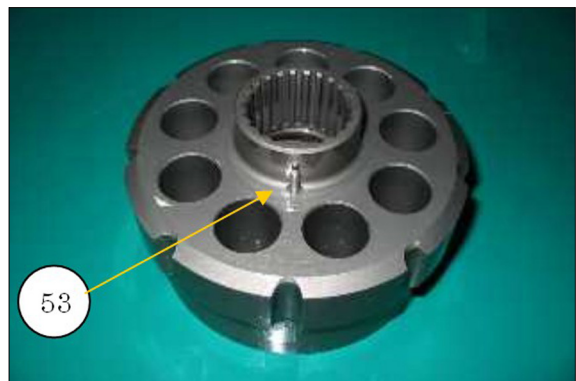

11078TM88

- (17) Install retainer ball(52) to the cylinder barrel. Put clean hydraulic oil on retainer ball(52).



11078TM89

(18) Install piston assemblies(50) in their original holes of retainer(49).

(19) Put clean hydraulic oil in the bores of the cylinder barrel and piston assemblies(50). Install the piston assemblies with the retainer in their original bores in cylinder barrel(51).

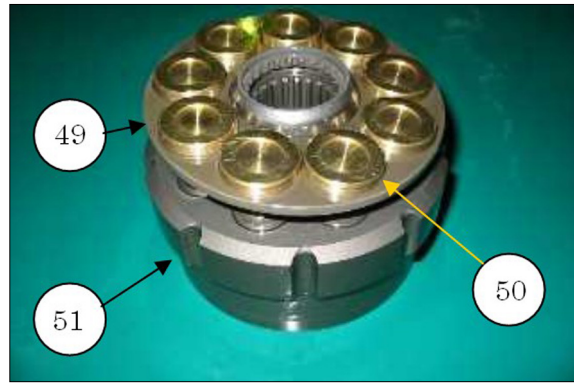

(20) Put clean hydraulic oil on the sliding surfaces of the cam, nine piston shoe surfaces sliding against cam, and on the splined shaft of the motor. Then, put the travel motor body on its side and install cylinder barrel assembly(48) on the shaft as a unit.

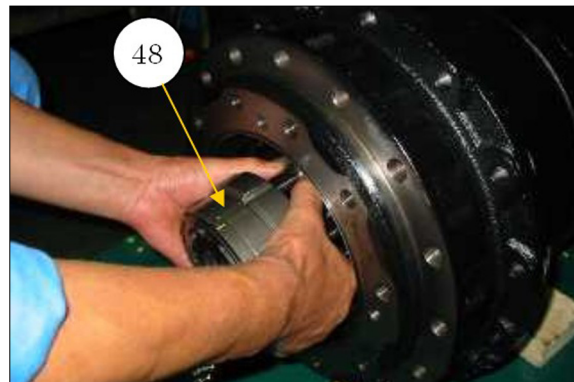

(21) Put clean hydraulic oil on two friction plates(46) and two steel plates(47). Install the plates in alternating order in the travel motor body. Start with a friction plate and end with a steel plate.

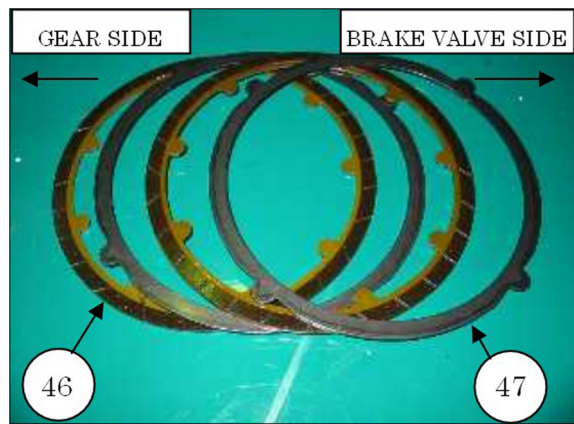

(22) Make sure brake piston(41) is completely clean and free of dirt and debris. Check the condition of back-up rings(44)(45) and O-rings(42)(43). If any of them have any damage, replace them with new ones. Install back up rings(44)(45) and O-rings(42)(43) on brake piston(41) as shown. Put some grease on the back-up rings and the O-rings. Be careful about the installing position of O-rings and back-up rings.

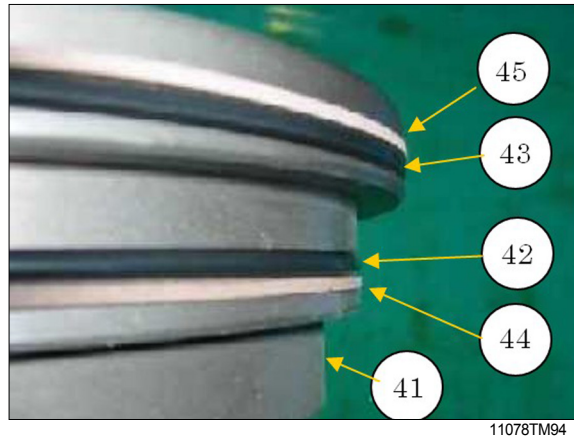

11078TM94

(23) Put clean hydraulic oil on the surface of the body casing, which makes contact with brake piston(41). Install brake piston(41) in the travel motor body using a soft-faced hammer.



11078TM95

(24) Install shim(40) in the brake piston. Next, install two disk springs(39) in the piston. The combination of the disk spring in installing is a shown. Install three O-rings(36)(37)(38) in the travel motor body.

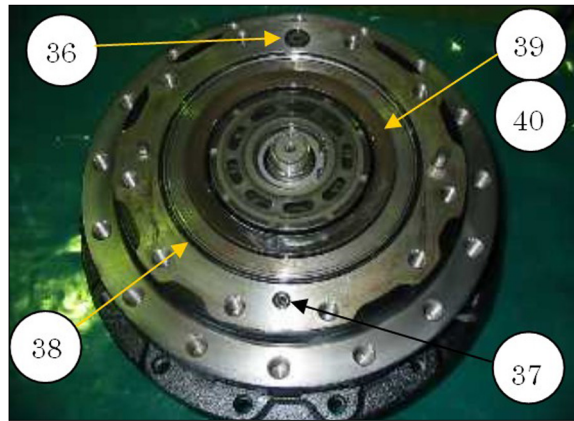

11078TM96

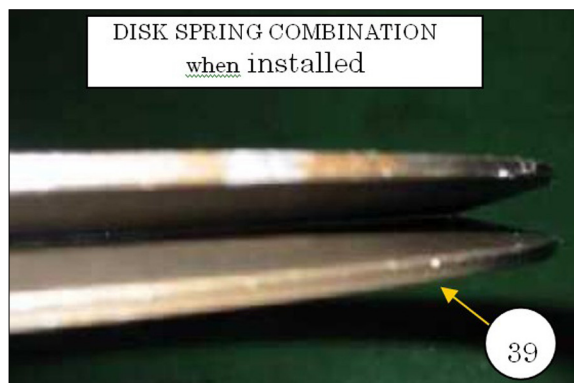

11078TM96

(25) Install bearing(34) and location pin(35) in the brake valve.

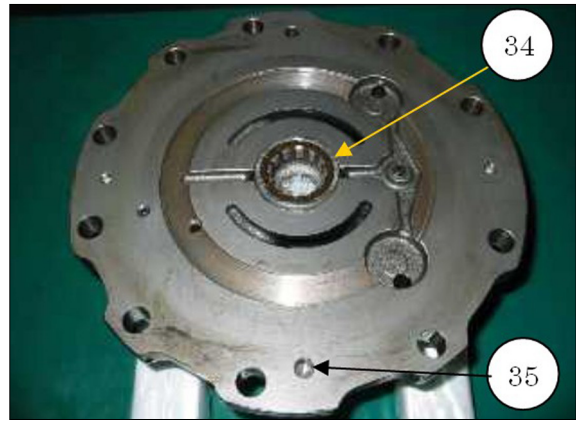

11078TM98

(26) Put the motor cover upside-down on wood blocks. Put some clean hydraulic oil on spool assembly(12), and install it in the valve body. Install washer(11) and then spring(10) in the valve body. Install O-ring(94) as shown.

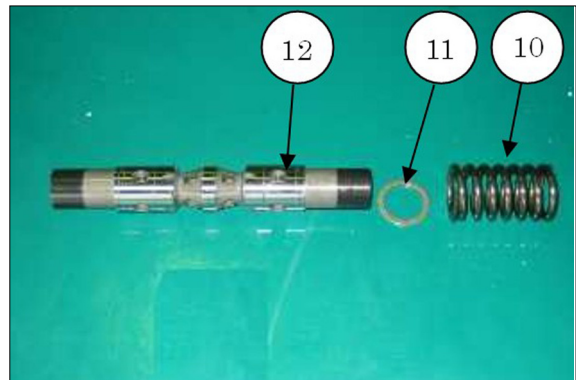

11078TM99



11078TM100

(27) Install cover(32) and four bolts(31). Tighten the bolts to a torque of **78.5±7.8 N m(57.9±5.8lbf ft)**. Be careful not to let the spool slip off the motor cover. The spool assembly(12) is not fixed yet.

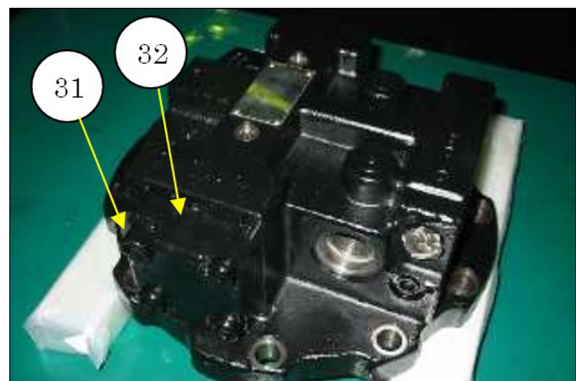

11078TM101

(28) Put O-ring(30) on plug(25). Install plug (25) to the brake valve. Tighten the plug(25) to a torque of $78.5 \pm 7.8 \text{ N} \cdot \text{m}$ ($57.9 \pm 5.8 \text{ lbf} \cdot \text{ft}$).

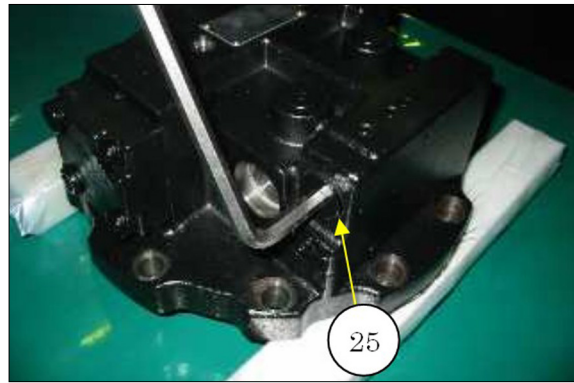

11078TM104

(29) Install rod(28), spring guide(27) and spring(26) to the brake valve.

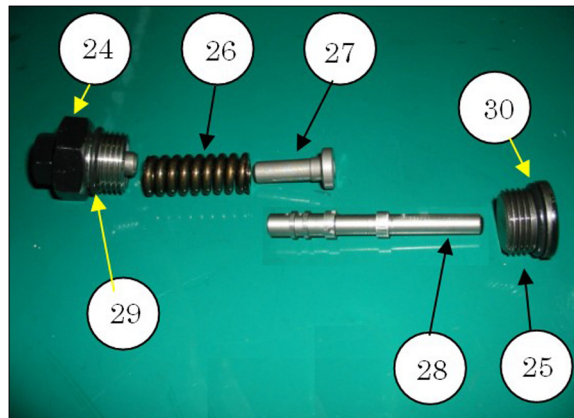

11078TM102

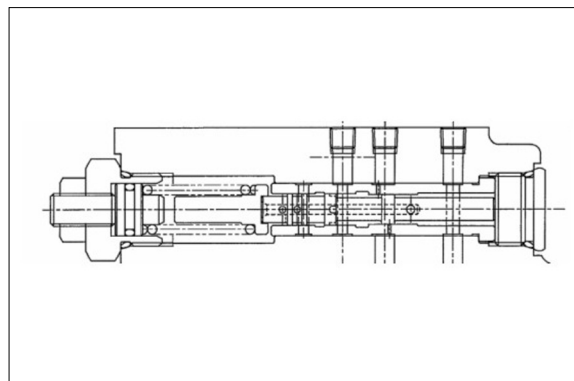

11078TM103

(30) Put O-ring(29) on plug assembly(24). Install plug assembly(24) to the brake valve. Tighten the plug assembly(24) to a torque of $78.5 \pm 7.8 \text{ N} \cdot \text{m}$ ($57.9 \pm 5.8 \text{ lbf} \cdot \text{ft}$).

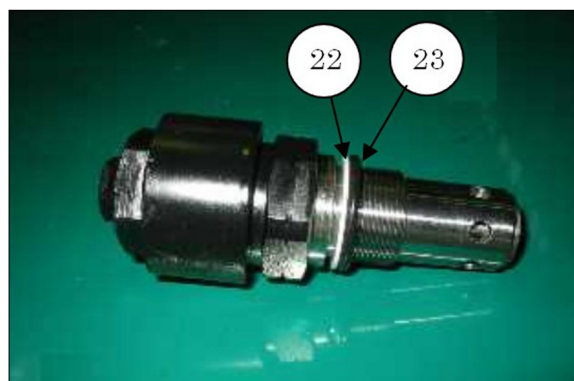

11078TM106

(31) Install back-up ring(22) and O-rings(23) on the relief valve as shown.

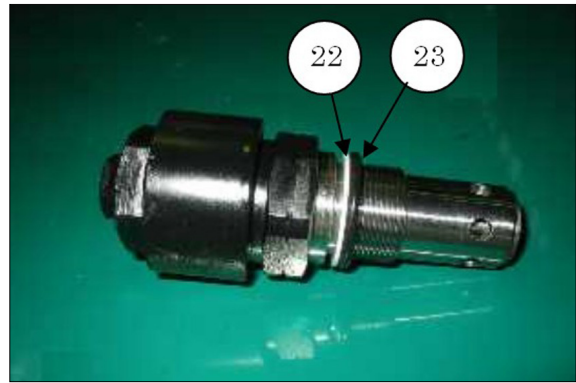

11078TM106

(32) Install relief valve(21) in the travel brake valve body as shown. Tighten the relief valve body to a torque of $196 \pm 19.6 \text{ N} \cdot \text{m}$ ($145 \pm 14.5 \text{ lbf} \cdot \text{ft}$).

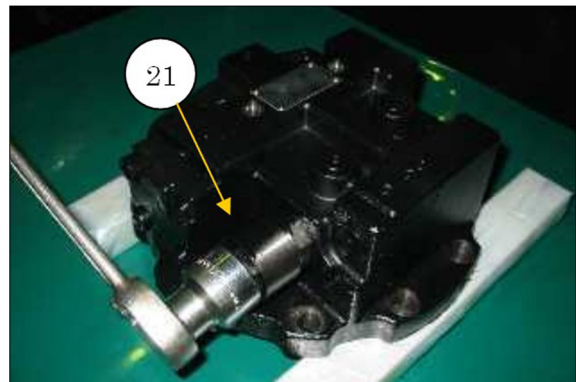

11078TM107

(33) Install two balls(20) in the brake valve. Put O-rings(19) on plugs(18). Install the plugs to the travel brake valve. Tighten the plugs to a torque of $19.6 \pm 2.0 \text{ N} \cdot \text{m}$ ($14.5 \pm 1.5 \text{ lbf} \cdot \text{ft}$).

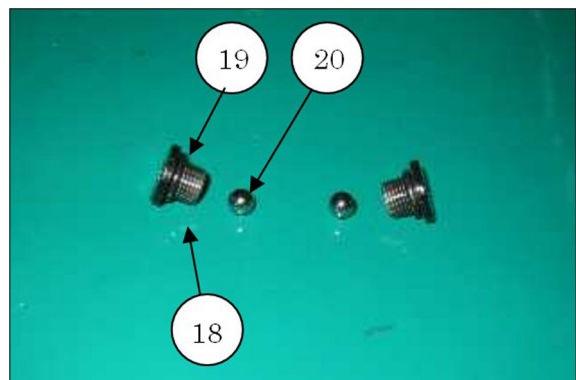

11078TM108

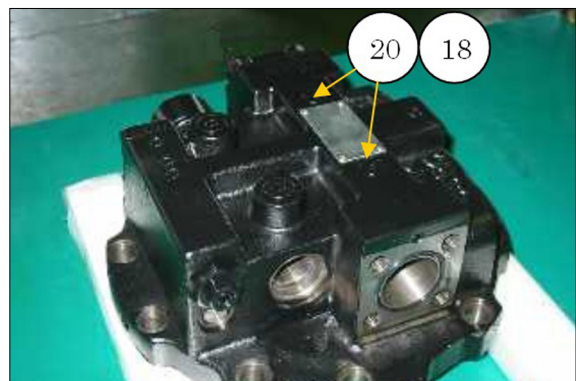

11078TM109

(34) Put spool(17), spring(16), and stopper(15) in the brake valve body. Put the O-ring on plug(14). Install plug(14) to the travel brake valve. Tighten the plug to a torque of $49 \pm 4.9 \text{ N}\cdot\text{m}$ ($36.1 \pm 3.6 \text{ lbf}\cdot\text{ft}$).

Put O-ring(13) on the brake valve body.

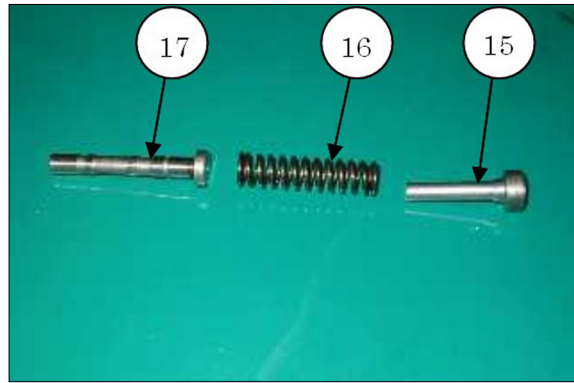

11078TM110

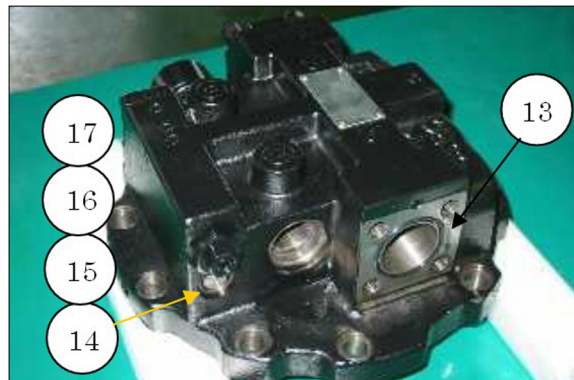

11078TM111

(35) Install plate(11) and then spring(10) in the brake valve.

Then, install cover(9) with four bolts(8). Tighten the bolts(8) to a torque of $78.5 \pm 7.8 \text{ N}\cdot\text{m}$ ($57.9 \pm 5.8 \text{ lbf}\cdot\text{ft}$).

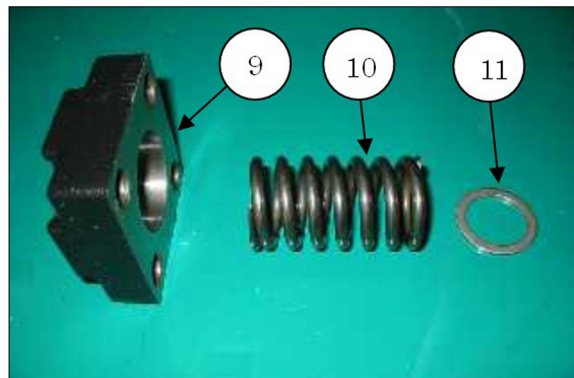

11078TM112



11078TM113

- (36) Put the brake valve upside-down.
Install valve plate(33) in its original position on the brake valve.
Put some clean hydraulic oil on the valve plate surface.



11078TM114

- (37) Position brake valve(3) on the body casing. Install ten bolts(2) that hold it. Tighten the bolts to a torque of 191 ± 14.7 N·m (141 ± 10.8 lbf·ft).

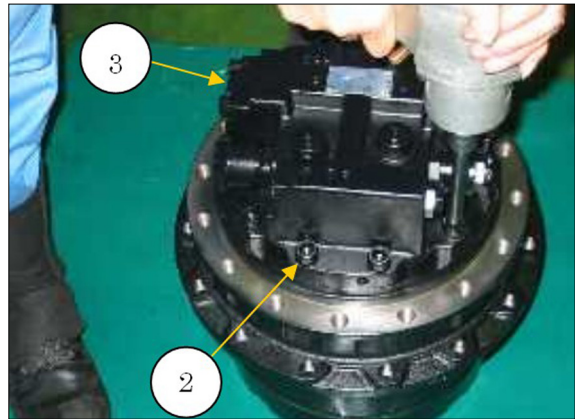

11078TM115

- (38) Instal back-up ring(6) and O-ring(7) on the relief valve.

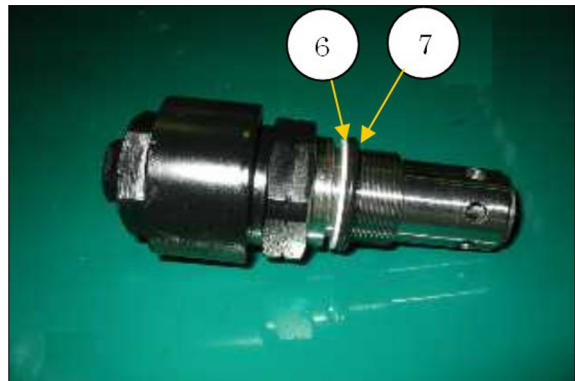

11078TM116

- (39) Install relief valve(1) to travel brake valve (3).
Tighten the relief valve body to a torque of 196 ± 19.6 N·m (145 ± 14.5 lbf·ft).

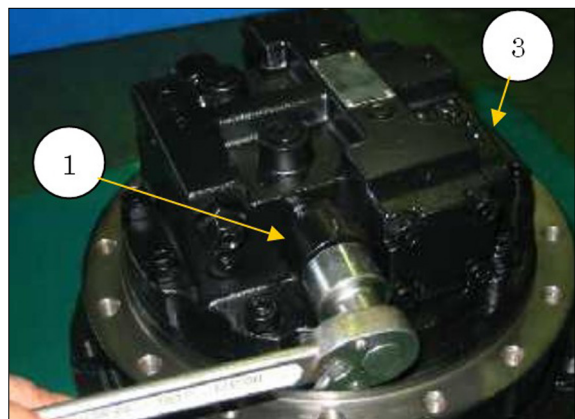

11078TM117

(40) Place the travel motor with brake valve upside down as shown. Apply torque to shaft(90) to confirm the parking brake torque. If the shaft starts rotating by a torque of more than **239N·m (176lbf·ft)**, it satisfies the spec. If the motor output shaft rotates at a less torque than above, shim(40) needs to be replaced with thicker one in order to get a higher parking brake torque.

There are some variations of thickness available for shim(40). The thicker the shim is, the higher the parking brake torque is. The thinner the shim is, the lower the parking torque is.

▲ Don't apply too thick shim to the travel motor. It may cause damage to braking parts because of malfunction in brake-releasing action in traveling.

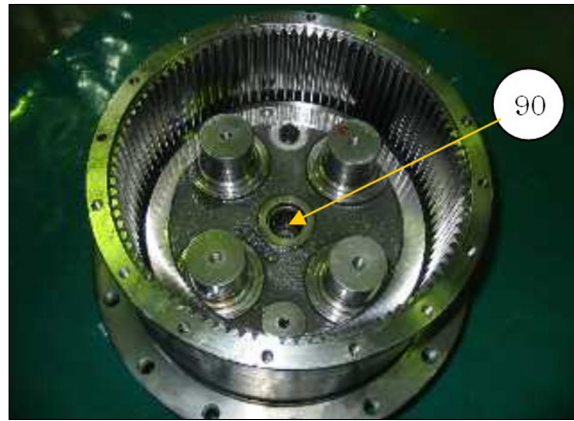

11078TM118

(41) Install four plates(80), four bushes(79), four bearings(78) and four planetary gears(77) as shown.

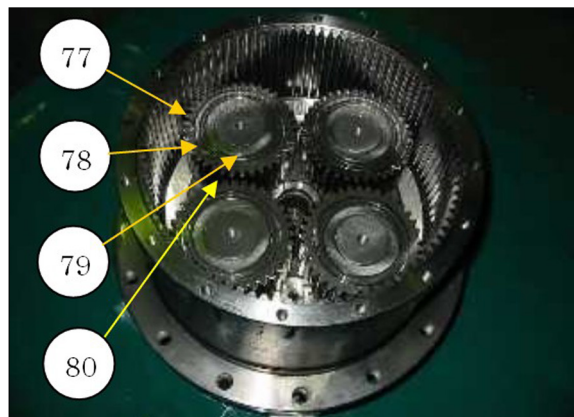

11078TM119

(42) Install snap ring(74) to sun gear(73).

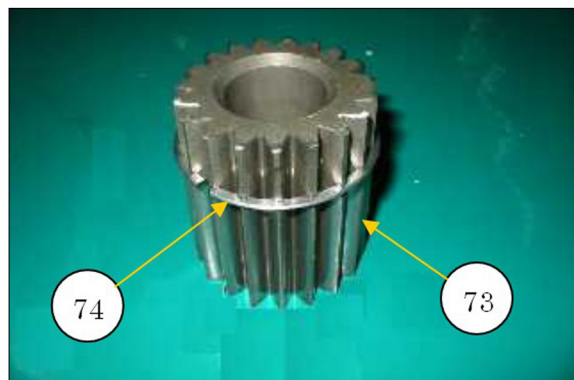

11078TM120

- (43) Put thrust plate(76) as shown. Apply **Thread Lock "THREE BOND 2403"** to bolts(75). Install four bolts(75). Tighten the bolts to a torque of **68.6 ± 4.9 N·m (50.6 ± 3.6 lbf·ft)**. Then install sun gear(73).

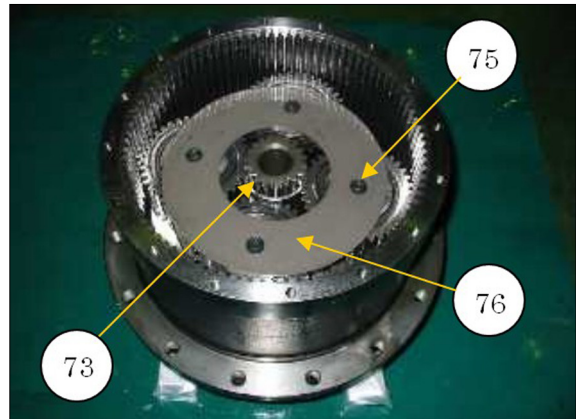

11078TM121

- (44) Install three inner races(72) on the carrier shaft.

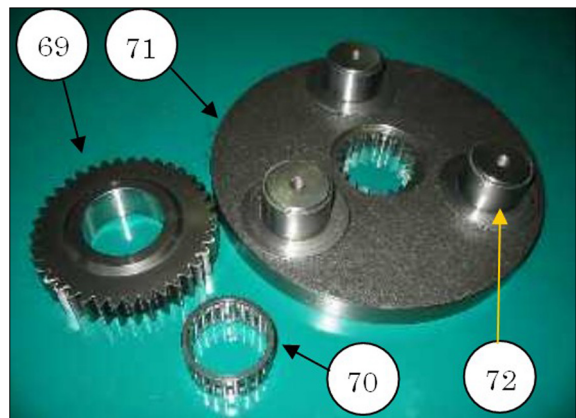

11078TM122

- (45) Install carrier(71) as shown.



11078TM123

- (46) Install three bearings(70) and three planetary gears(69) on the carrier shaft assembly. Then install sun gear(68).

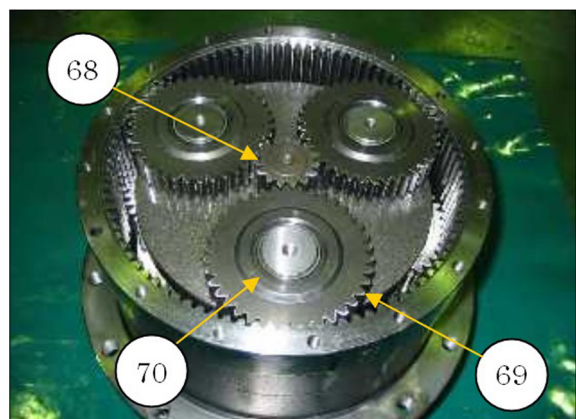

11078TM124

(47) Put thrust plate(67) on the carrier. Apply **Thread Lock "THREE BOND 2403"** to bolts(66). Install three bolts(66) that hold plate(67) to the planetary carrier. Tighten the bolts to a torque of **68.6±4.9 N·m (50.6±3.7lbf·ft)**.

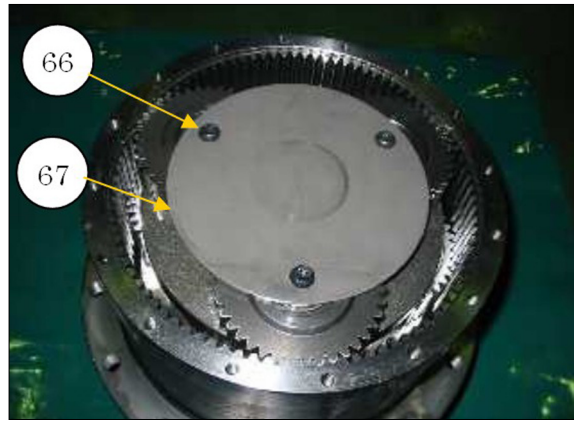

11078TM125

(48) Make sure the machined surface of gear casing(65) and cover(64) is completely clean, free of dirt and debris, and is dry. Put a bead of **Gasket Maker "THREE BOND 1389"** around the machined surface of the gear casing as shown. Put cover(64) in its original position on the gear casing.

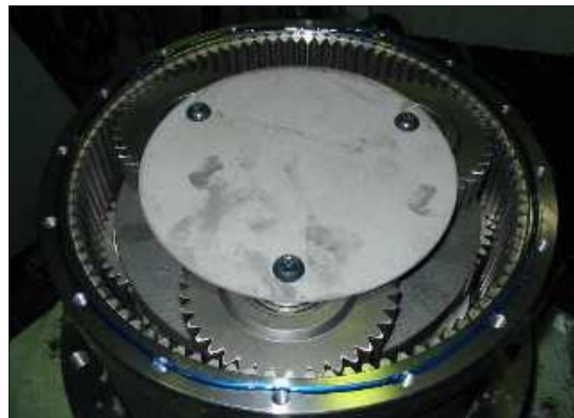

11078TM126

(49) Install sixteen bolts(62) and sixteen washers(63) that hold the cover. Tighten the bolts to a torque of **35.3±2N·m(26±1.5lbf·ft)**.

Install lubricating oil from the drain port. The capacity of the travel motor is **2.5liters(0.55U.K.gal; 0.66U.S.gal)**.

▲ To prevent damage to the motor, the case of the motor must be filled with hydraulic oil before operation.

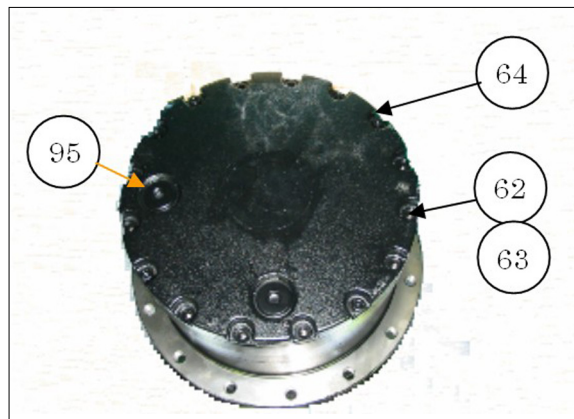

11078TM127

This is the end of assembling process

GROUP 7 RCV LEVER

1. REMOVAL AND INSTALL

1) REMOVAL

- (1) Lower the work equipment to the ground and stop the engine.
- (2) Operate the control levers and pedals several times to release the remaining pressure in the hydraulic piping.
- (3) Loosen the breather slowly to release the pressure inside the hydraulic tank.

▲ Escaping fluid under pressure can penetrate the skin causing serious injury.

- (4) Loosen the socket bolt(2).
- (5) Remove the cover of the console box.
- (6) Disconnect pilot line hoses(3).
- (7) Remove the pilot valve assembly(1).
※ When removing the pilot valve assembly, check that all the hoses have been disconnected.

2) INSTALL

- (1) Carry out installation in the reverse order to removal.
- (2) Confirm the hydraulic oil level and check the hydraulic oil leak or not.

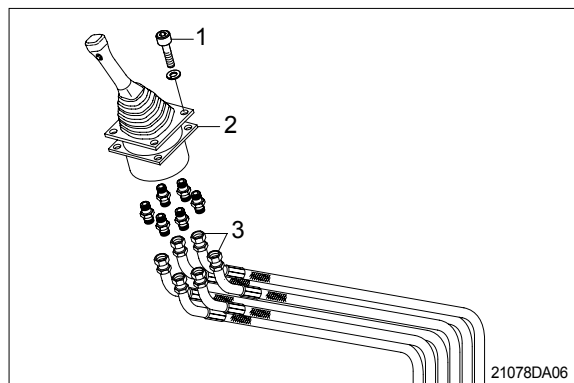

2. DISASSEMBLY AND ASSEMBLY

1) STRUCTURE

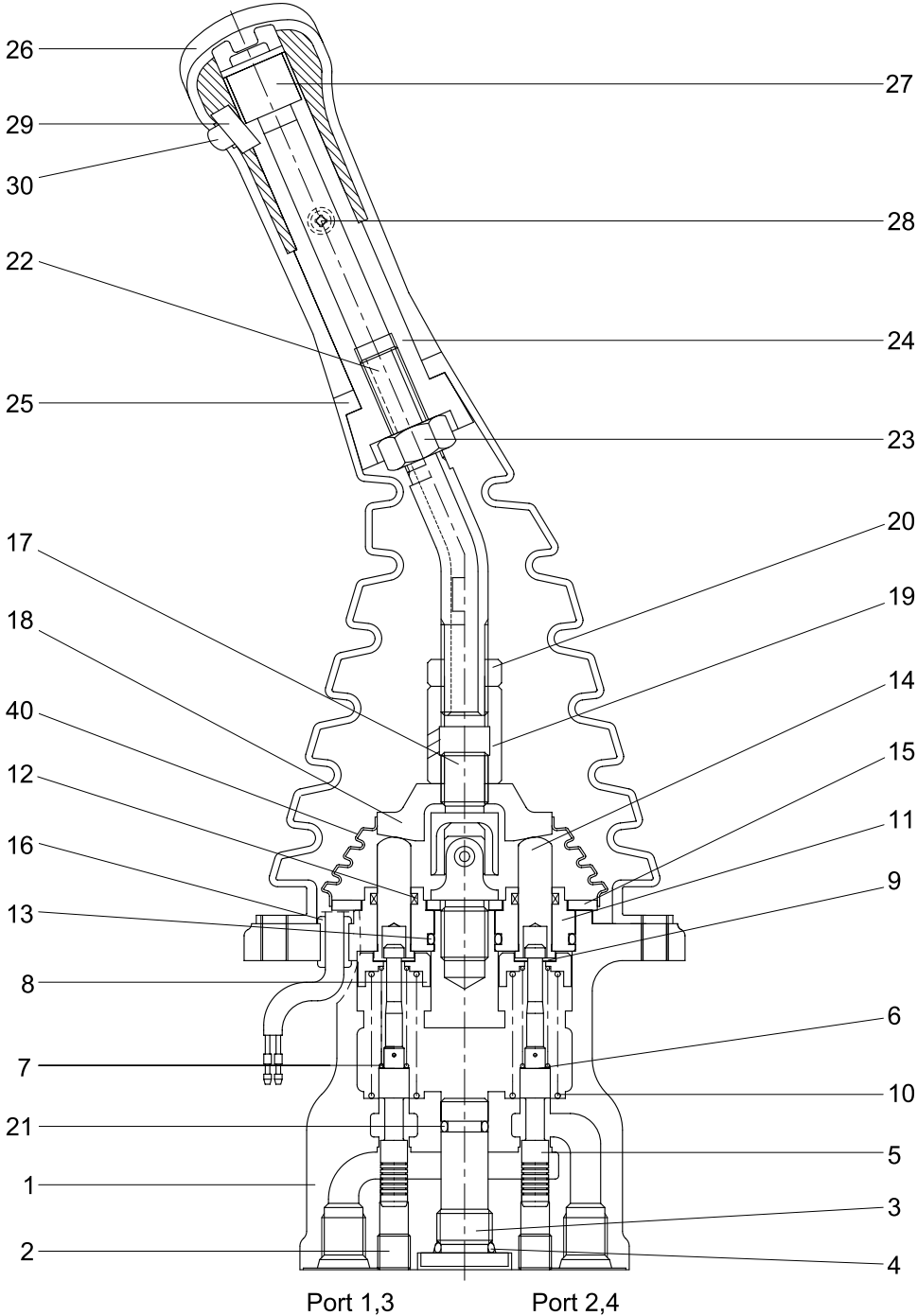

14072SF80

1	Case	12	Rod seal	22	Handle connector
2	Plug	13	O-ring	23	Nut
3	Plug	14	Push rod	24	Insert
4	O-ring	15	Plate	25	Boot
5	Spool	16	Bushing	26	Handle
6	Shim	17	Joint assembly	27	Switch assembly
7	Spring	18	Swash plate	28	Screw
8	Spring seat	19	Adjusting nut	29	Switch assembly
9	Stopper	20	Lock nut	30	Switch cover
10	Spring	21	O-ring	40	Boot
11	Plug				

2) TOOLS AND TIGHTENING TORQUE

(1) Tools

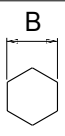
Tool name	Remark	
Allen wrench	6	
Spanner	22	
	27	
(+) Driver	Length 150	
(-) Driver	Width 4~5	
Torque wrench	Capable of tightening with the specified torques	

(2) Tightening torque

Part name	Item	Size	Torque	
			kgf · m	lbf · ft
Plug	2	PT 1/8	3.0	21.7
Joint	18	M14	3.5	25.3
Swash plate	19	M14	5.0±0.35	36.2±2.5
Adjusting nut	20	M14	5.0±0.35	36.2±2.5
Lock nut	21	M14	5.0±0.35	36.2±2.5
Screw	29	M 3	0.05	0.36

3) DISASSEMBLY

- (1) Clean pilot valve with kerosene.
 - ※ Put blind plugs into all ports
- (2) Fix pilot valve in a vise with copper(or lead) sheets.
- (3) Remove end of boot(26) from case(1) and take it out upwards.

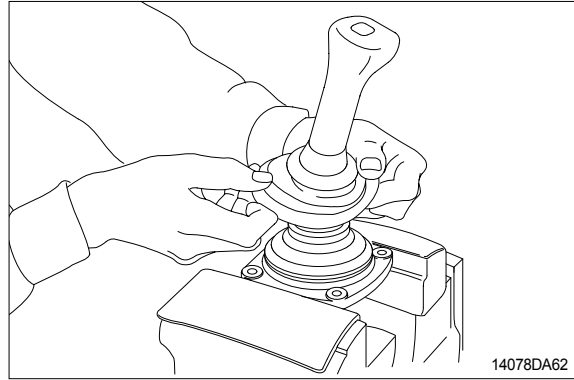

- ※ For valve with switch, remove cord also through hole of casing.

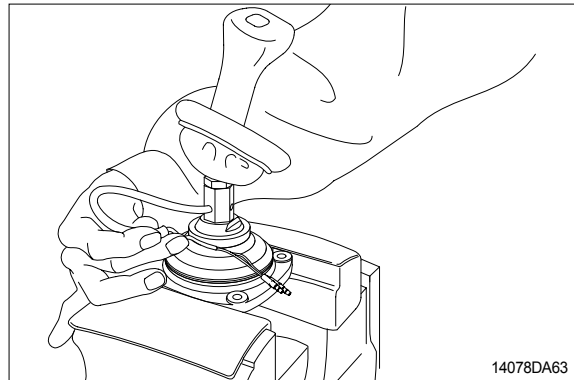

- (4) Loosen lock nut(21) and adjusting nut(20) with spanners on them respectively, and take out handle section as one body.

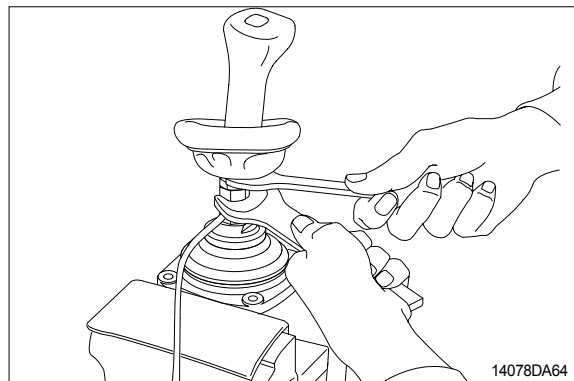

- (5) Remove the boot(40)

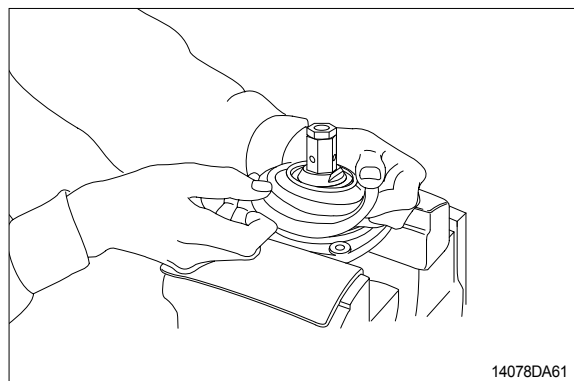

- (6) Loosen adjusting nut(20) and plate(19) with spanners on them respectively, and remove them.

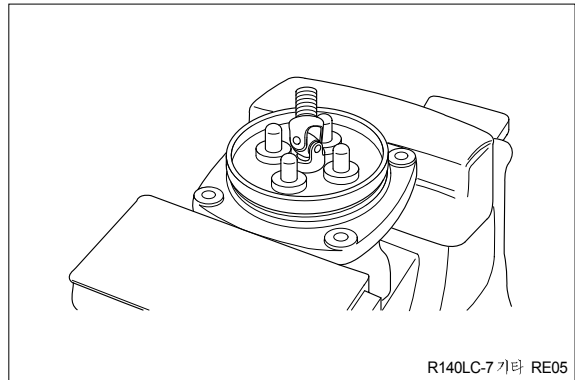
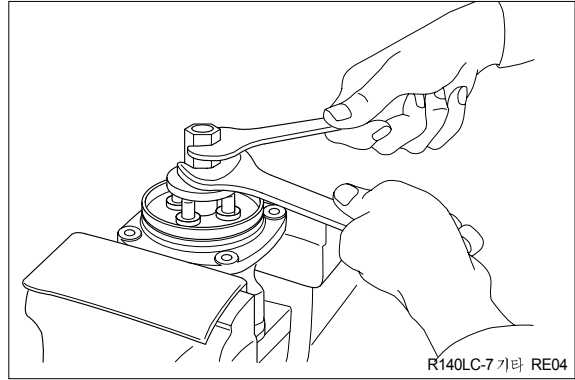

- (7) Turn joint anticlockwise to loosen it, utilizing jig(Special tool).
※ When return spring(10) is strong in force, plate(16), plug(11) and push rod(14, 15) will come up on loosening joint. Pay attention to this.

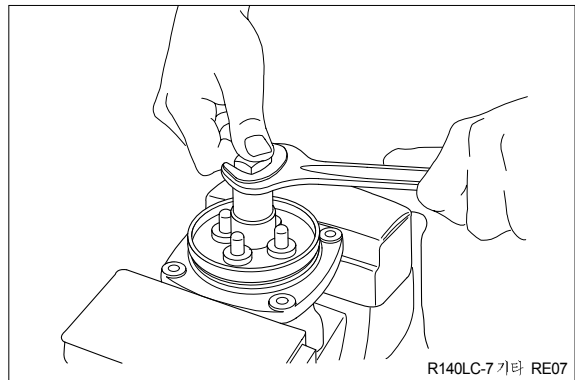
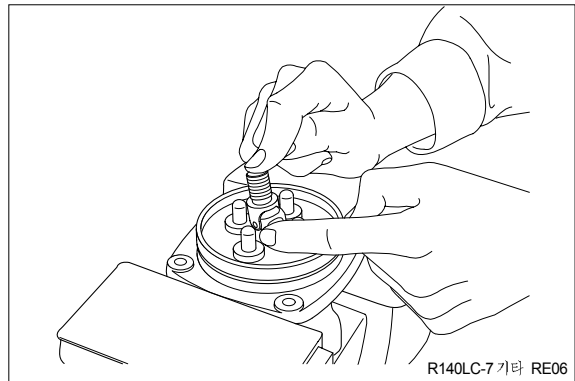

(8) Remove plate(16).

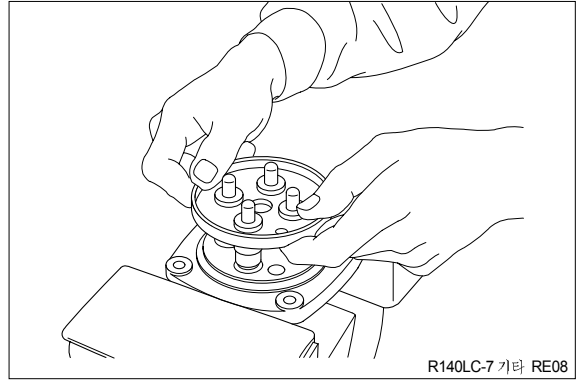

(9) When return spring(10) is weak in force, plug(11) stays in casing because of sliding resistance of O-ring.

- ※ Take it out with minus screwdriver.
Take it out, utilizing external periphery groove of plug and paying attention not to damage it by partial loading.
- ※ During taking out, plug may jump up due to return spring(10) force.
Pay attention to this.

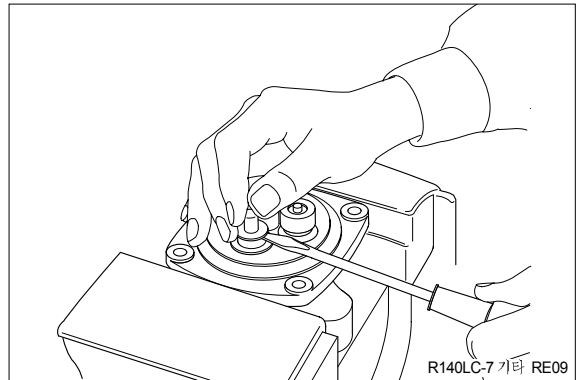

(10) Remove reducing valve subassembly and return spring(10) out of casing.

- ※ Record relative position of reducing valve subassembly and return springs.

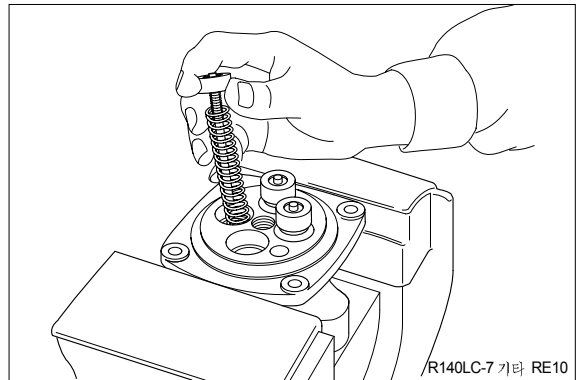

(11) Loosen hexagon socket head plug(2) with hexagon socket screw key.

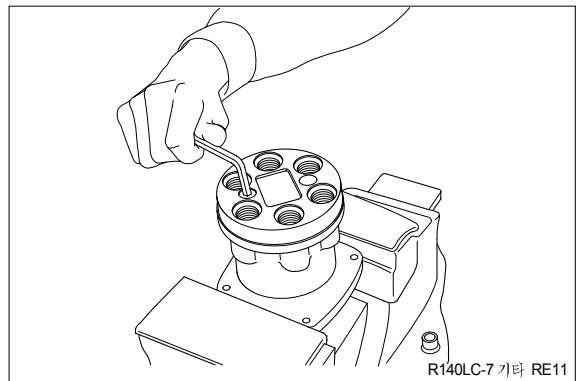

(12) For disassembling reducing valve section, stand it vertically with spool(5) bottom placed on flat workbench. Push down spring seat(8, 31) and remove two pieces of semicircular stopper(9) with tip of small minus screwdriver.

- ※ Pay attention not to damage spool surface.
- ※ Record original position of spring seat(8, 31).
- ※ Do not push down spring seat more than 6mm.

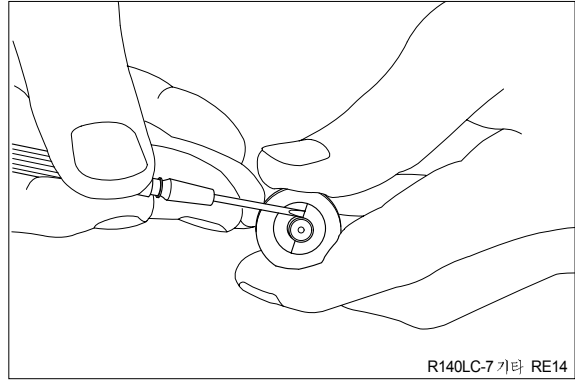

(13) Separate spool(5), spring seat(8, 31), spring(7, 30) and shim(6) individually.

- ※ Until being assembled, they should be handled as one subassembly group.

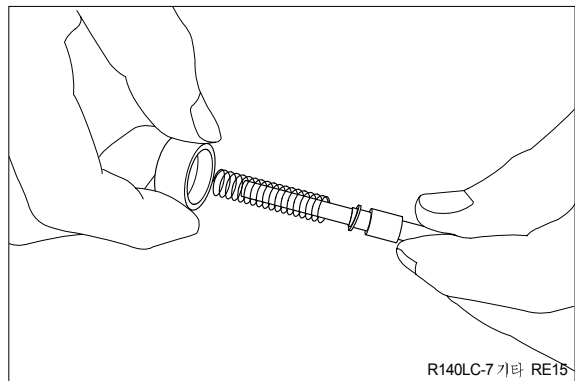

(14) Take push rod(14, 15) out of plug(11).

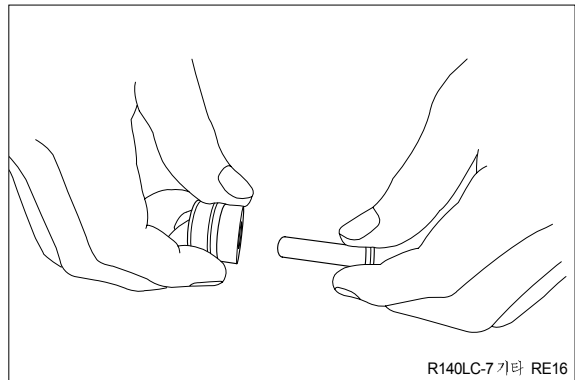

(15) Remove O-ring(13) and seal(12) from plug(11).

Use small minus screwdriver or so on to remove this seal.

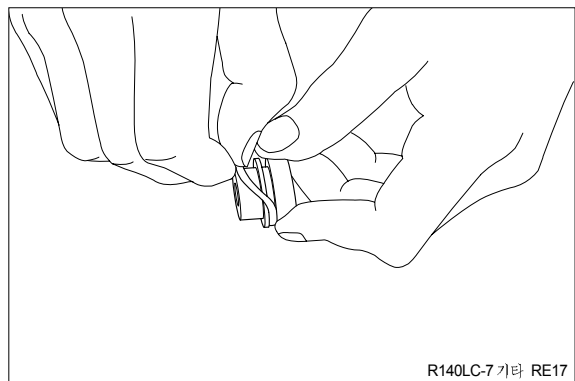

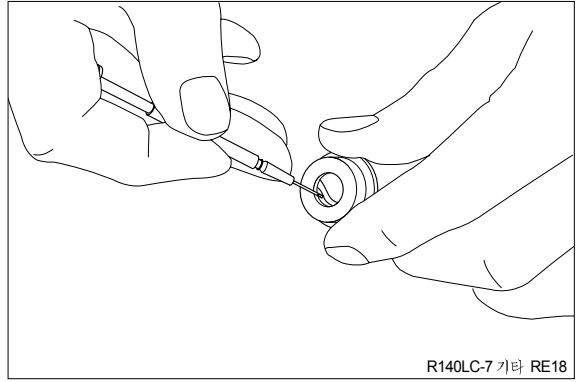

(16) Remove lock nut(21) and then boot(26).

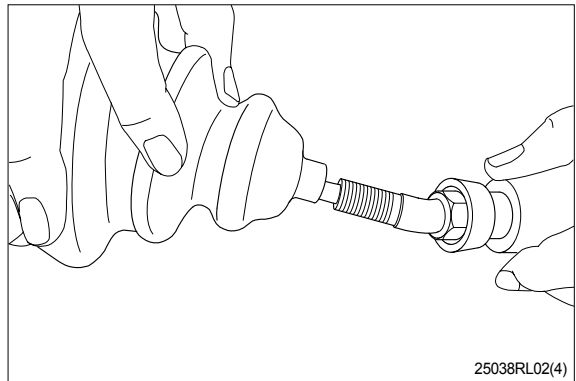
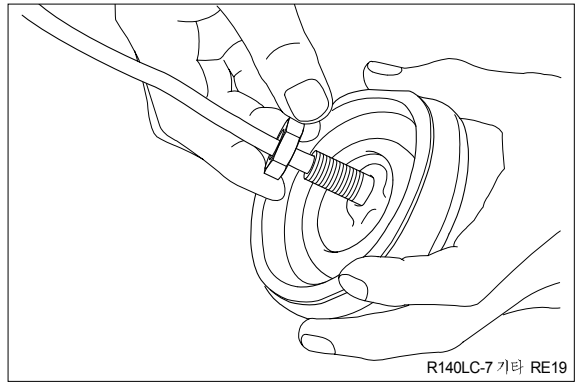

(17) Cleaning of parts

- ① Put all parts in rough cleaning vessel filled with kerosene and clean them (Rough cleaning).
 - ※ If dirty part is cleaned with kerosene just after putting it in vessel, it may be damaged. Leave it in kerosene for a while to loosen dust and dirty oil.
 - ※ If this kerosene is polluted, parts will be damaged and functions of reassembled valve will be degraded.
Therefore, control cleanliness of kerosene fully.
- ② Put parts in final cleaning vessel filled with kerosene, turning it slowly to clean them even to their insides (Finish cleaning).
 - ※ Do not dry parts with compressed air, since they will be damaged and/or rusted by dust and moisture in air.

(18) Rust prevention of parts

- Apply rust-preventives to all parts.
- ※ If left as they are after being cleaned, they will be rusted and will not display their functions fully after being reassembled.

4) ASSEMBLY

(1) Tighten hexagon socket head plug(2) to the specified torque.

※ Tighten two bolts alternately and slowly.

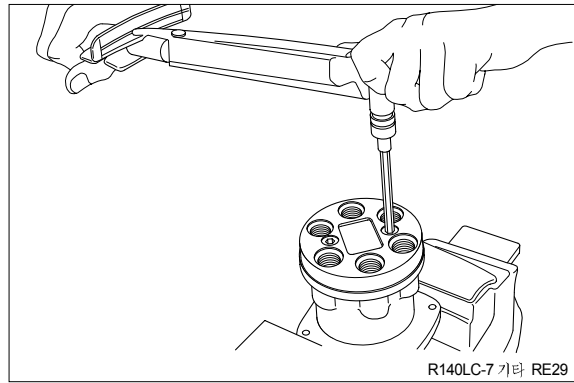

(2) Put shim(6), springs(7, 30) and spring seat(8, 31) onto spool(5) in this order.

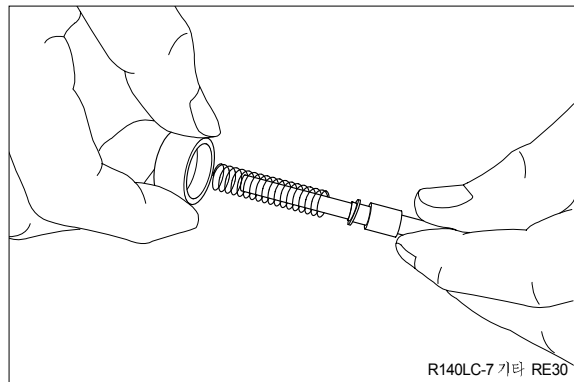

(3) Stand spool vertically with its bottom placed on flat workbench, and with spring seat pushed down, put two pieces of semicircular stopper(9) on spring seat without piling them on.

※ Assemble stopper(9) so that its sharp edge side will be caught by head of spool. Do not push down spring seat more than 6mm.

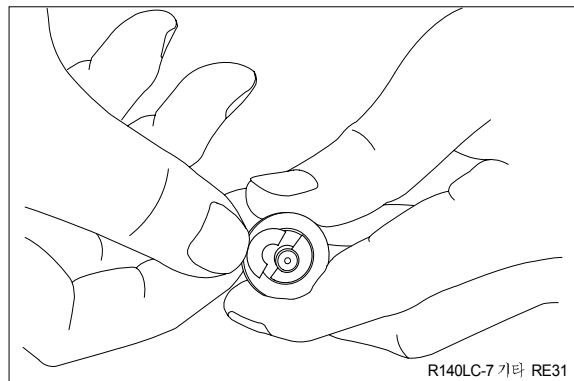

(4) Assemble spring(10) into casing.
Assemble reducing valve subassembly into casing.

※ Assemble them to their original positions.

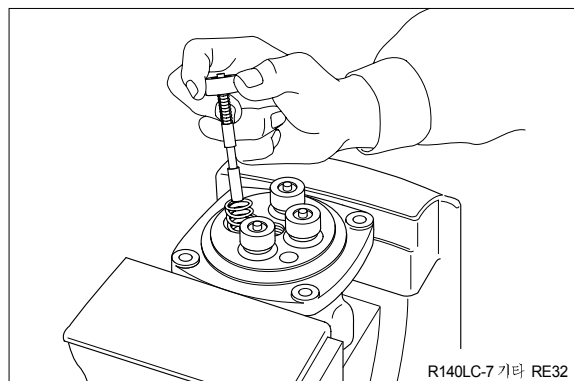

(5) Assemble O-ring(13) onto plug(11).

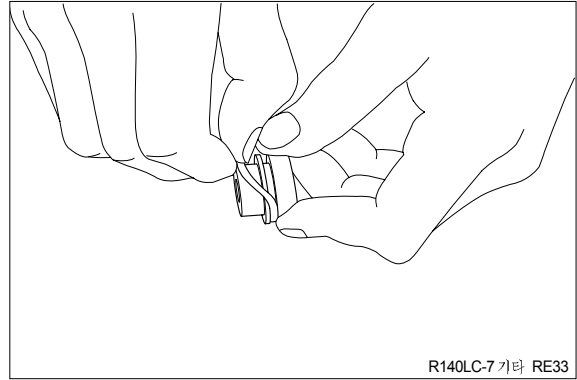

(6) Assemble seal(12) to plug(11).

※ Assemble seal in such lip direction as shown below.

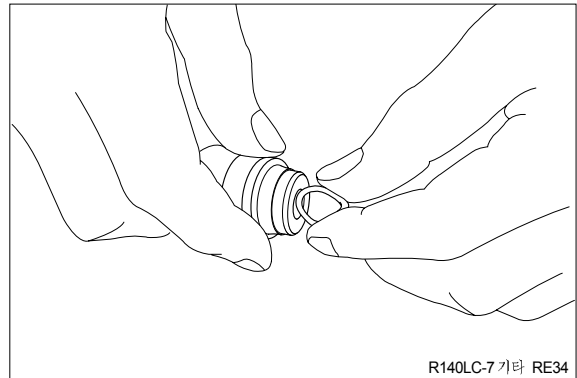

(7) Assemble push rod(14, 15) to plug(11).

※ Apply working oil on push-rod surface.

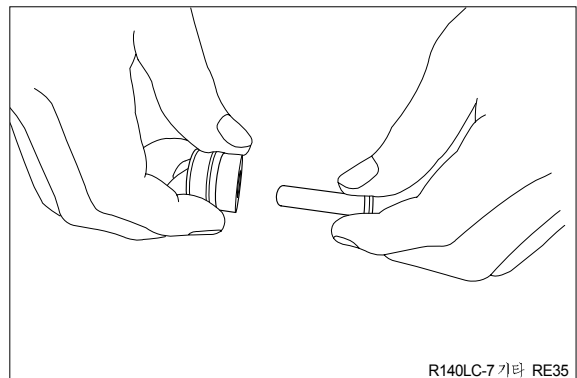

(8) Assemble plug subassembly to casing.

※ When return spring is weak in force, subassembly stops due to resistance of O-ring.

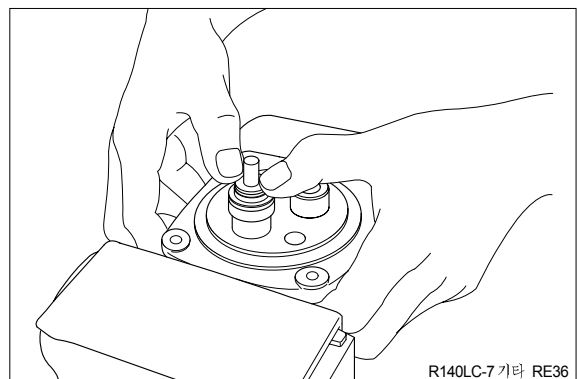

- (9) When return spring is strong in force, assemble 4 sets at the same time, utilizing plate(16), and tighten joint(18) temporarily.

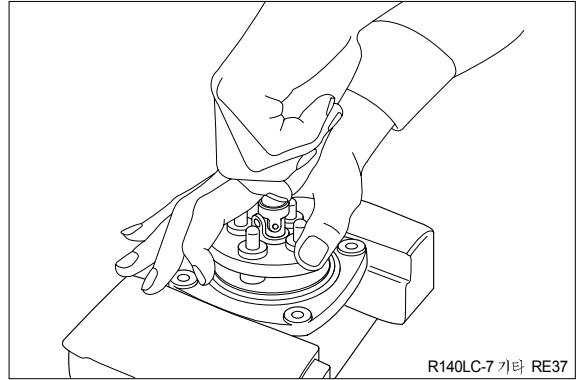

- (10) Fit plate(16).

- (11) Tighten joint(18) with the specified torque to casing, utilizing jig.

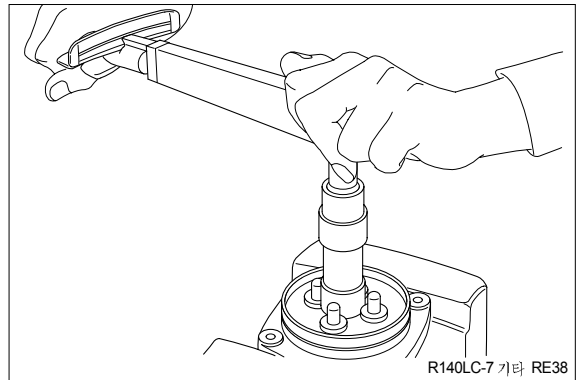

- (12) Assemble plate(19) to joint(18).

- ※ Screw it to position that it contacts with 4 push rods evenly.
- ※ Do not screw it over.

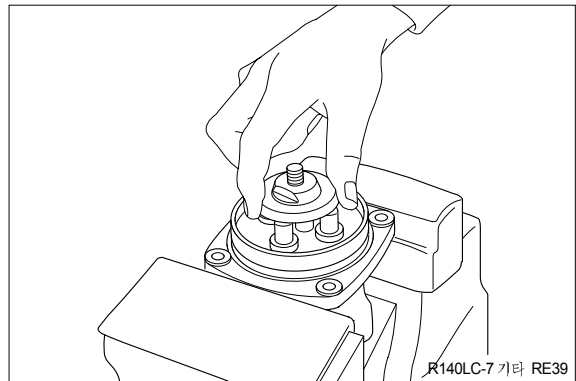

- (13) Assemble adjusting nut(20), apply spanner to width across flat of plate(19) to fix it, and tighten adjusting nut to the specified torque.

- ※ During tightening, do not change position of disk.

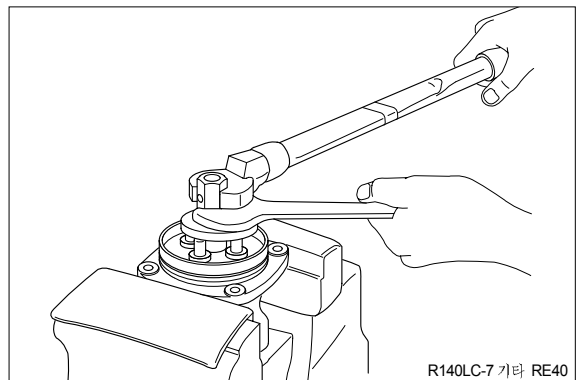

(14) Fit boot(40) to plate.

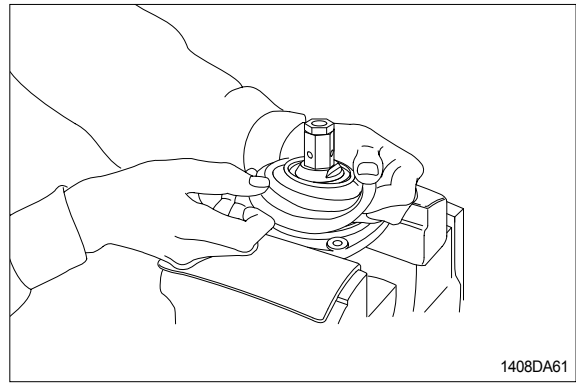

(15) Fit boot(26) and lock nut(21), and handle subassembly is assembled completely.

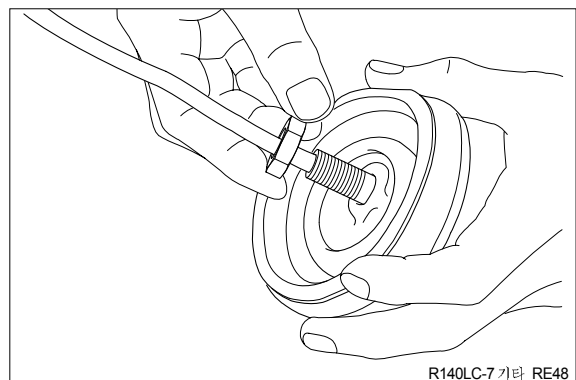
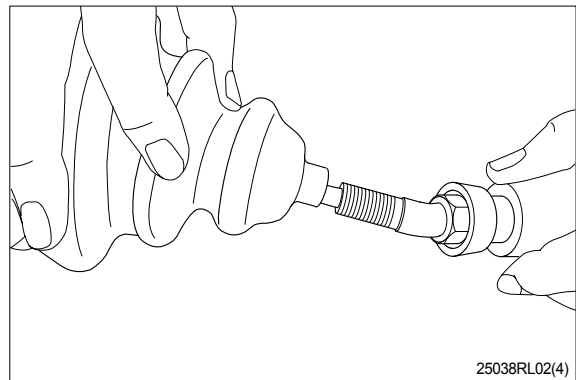

(16) Pull out cord and tube through adjusting nut hole provided in direction 60° to 120° from casing hole.

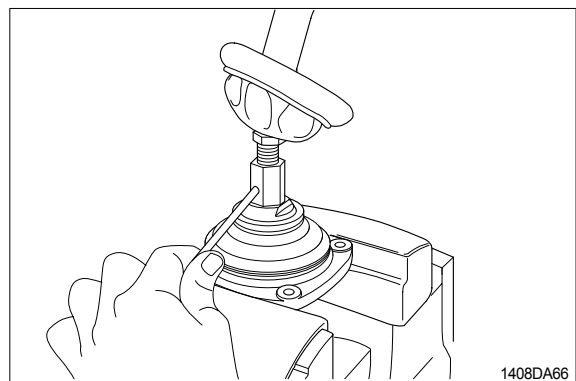

(17) Assemble bushing(17) to plate and pass cord and tube through it.

※ Provide margin necessary to operation.

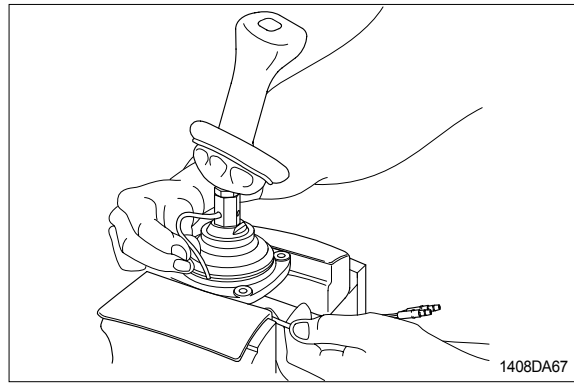

(18) Determine handle direction, tighten lock nut(21) to specified torque to fix handle.

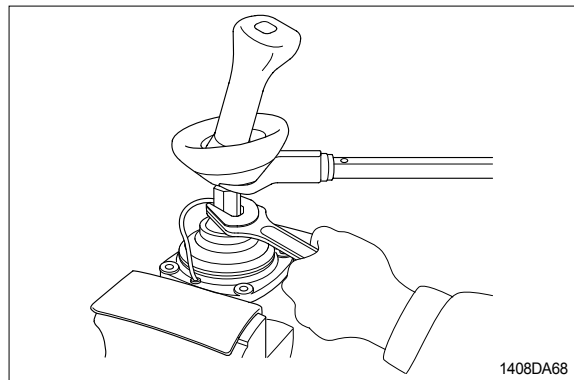

(19) Apply grease to rotating section of joint and contacting faces of disk and push rod.

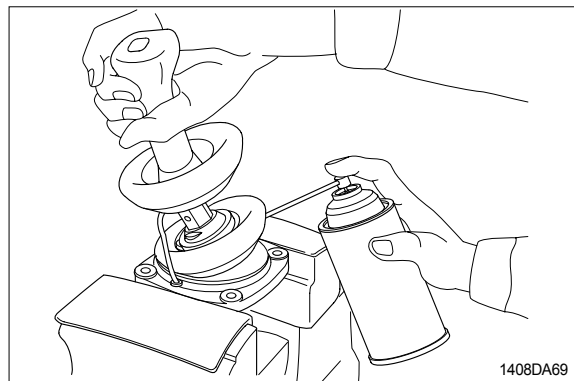

(20) Assemble lower end of bellows to casing.

(21) Inject volatile rust-preventives through all ports and then put blind plugs in ports.

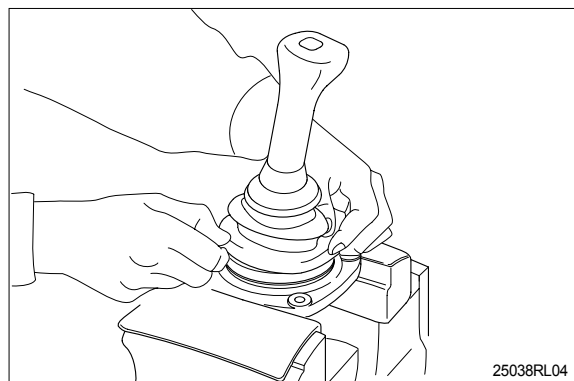

GROUP 8 TURNING JOINT

1. REMOVAL AND INSTALL

1) REMOVAL

- (1) Lower the work equipment to the ground and stop the engine.
- (2) Operate the control levers and pedals several times to release the remaining pressure in the hydraulic piping.
- (3) Loosen the breather slowly to release the pressure inside the hydraulic tank.

▲ Escaping fluid under pressure can penetrate the skin causing serious injury.

※ When pipes and hoses are disconnected, the oil inside the piping will flow out, so catch it in oil pan.

- (4) Disconnect all hoses.
 - (5) Sling the turning joint assembly (1) and remove the mounting bolt(2).
 - Weight : 54kg(119lb)
 - Tightening torque : $12.3 \pm 1.3\text{kgf} \cdot \text{m}$
($88.2 \pm 9.4\text{lbf} \cdot \text{ft}$)
 - (6) Remove the turning joint assembly.
- ※ When removing the turning joint, check that all the hoses have been disconnected.

2) INSTALL

- (1) Carry out installation in the reverse order to removal.
 - ※ Take care of turning joint direction.
 - ※ Assemble hoses to their original positions.
 - ※ Confirm the hydraulic oil level and check the hydraulic oil leak or not.

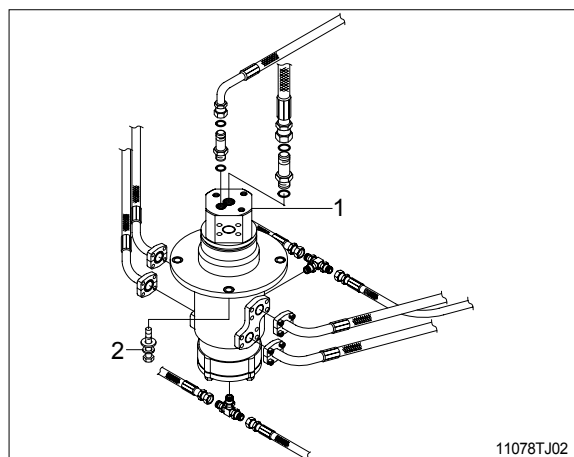
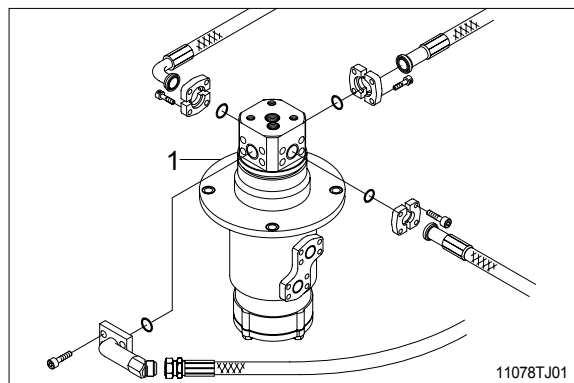

2. DISASSEMBLY AND ASSEMBLY

1) STRUCTURE

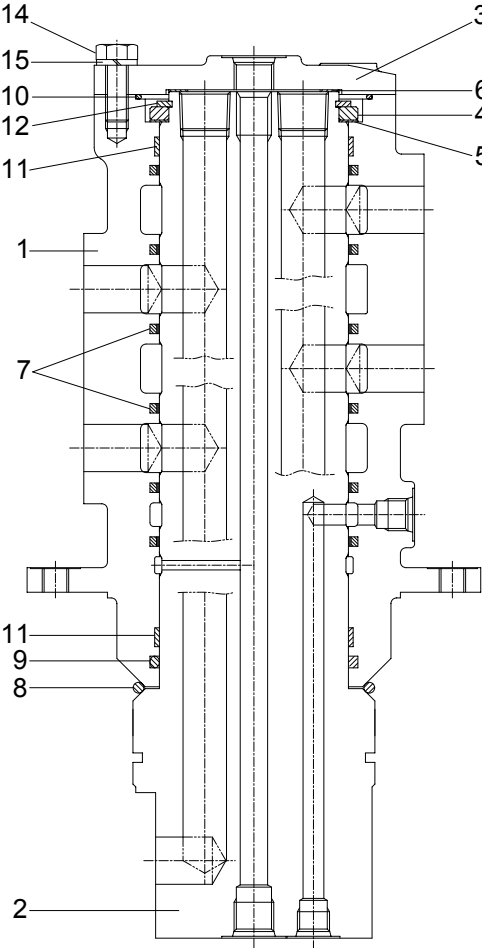

21078DA09

- | | | | | | |
|---|--------|----|--------------|----|---------------|
| 1 | Hub | 6 | Shim | 11 | Wear ring |
| 2 | Shaft | 7 | Slipper seal | 12 | Retainer ring |
| 3 | Cover | 8 | O-ring | 13 | Plug |
| 4 | Spacer | 9 | O-ring | 14 | Hexagon bolt |
| 5 | Shim | 10 | O-ring | 15 | Spring washer |

2) DISASSEMBLY

※ Before the disassembly, clean the turning joint.

- (1) Remove bolts(14), washer(15) and cover(3).

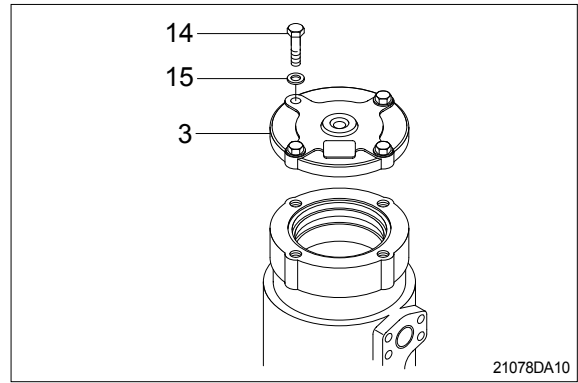

- (2) Remove shim(6) and O-ring(10).
- (3) Remove retainer ring(12), spacer(4) and shim(5).

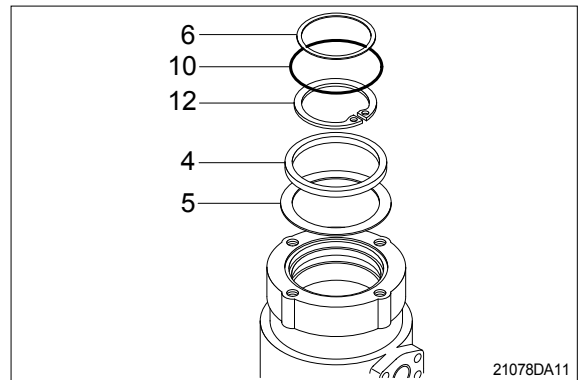

- (4) Place hub(1) on a V-block and by using a wood buffer at the shaft end, hit out shaft(2) to about 1/2 from the body with a hammer.

※ Take care not to damage the shaft(2) when remove hub(1) or rest it sideways.
※ Put a fitting mark on hub(1) and shaft(2).

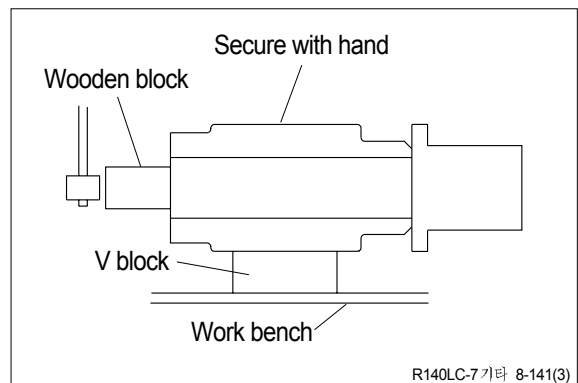

- (5) Remove six slipper seals(7) and O-ring(9), two ring wear(11) from hub(1).

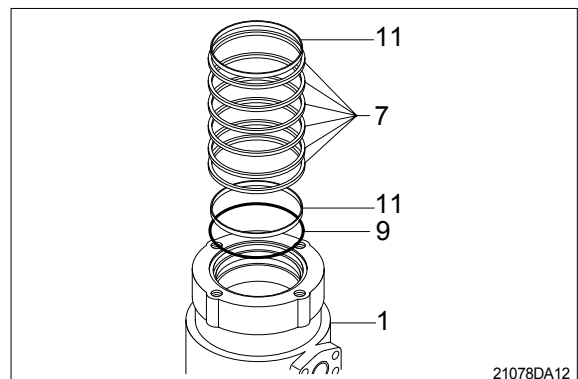

3) ASSEMBLY

- ※ Clean all parts.
- ※ As a general rule, replace oil seals and O-ring.
- ※ Coat the sliding surfaces of all parts with engine oil or grease before installing.

- (1) Fix seven slipper seal(7) and O-ring(9), two ring wear(11) to hub(1).
- (2) Fit O-ring(8) to shaft(2).

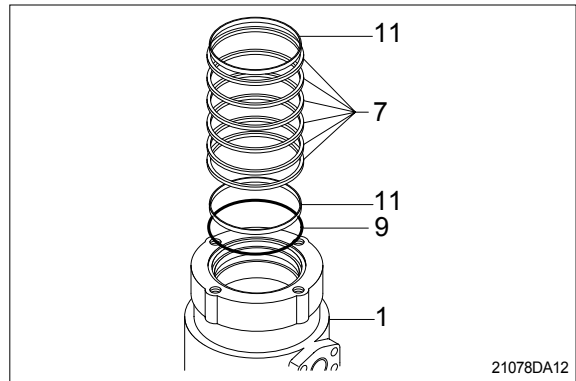

- (3) Set shaft(2) on block, tap hub(1) with a plastic hammer to install.

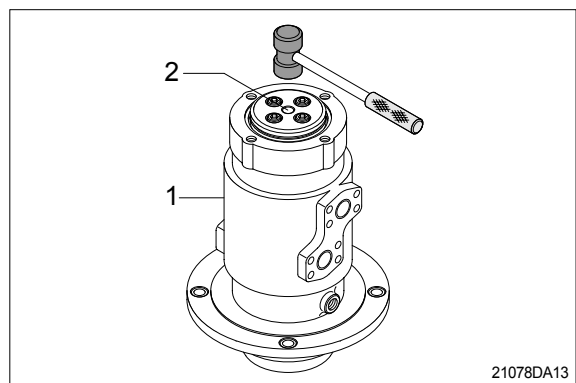

- (4) Fit shim(5), spacer(4) and retainer ring (12) to shaft(2).
- (5) Fit O-ring(10) to hub(1).
- (6) Fit shim(6) to shaft(2).

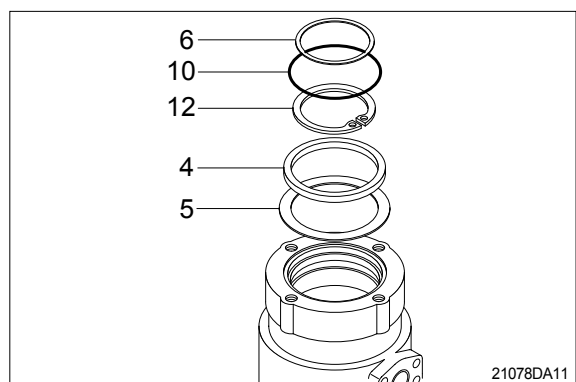

- (7) Install cover(3) to body(1) and tighten bolts(14).
· Torque : 10~12.5kgf · m(72.3~90.4lbf · ft)

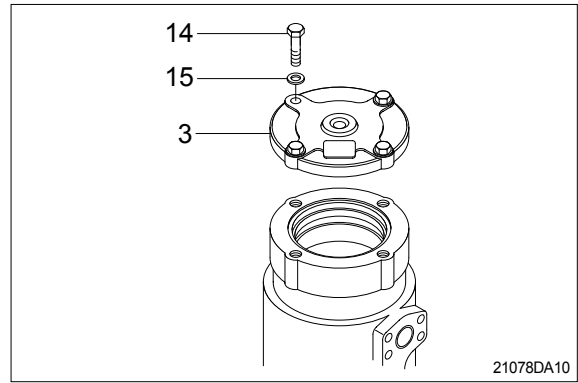

GROUP 9 BOOM, ARM AND BUCKET CYLINDER

1. REMOVAL AND INSTALL

1) BUCKET CYLINDER

(1) Removal

- ※ Expand the arm and bucket fully, lower the work equipment to the ground and stop the engine.
- ※ Operate the control levers and pedals several times to release the remaining pressure in the hydraulic piping.

▲ Loosen the breather slowly to release the pressure inside the hydraulic tank.

- ※ Escaping fluid under pressure can penetrate the skin causing serious injury. Fit blind plugs in the hoses after disconnecting them, to prevent dirt or dust from entering.

- ① Set block between bucket cylinder and arm.

- ② Remove bolt(2), nut(3) and pull out pin (1).

- ※ Tie the rod with wire to prevent it from coming out.

- ③ Disconnect bucket cylinder hoses(4) and put plugs(5) on cylinder pipe.

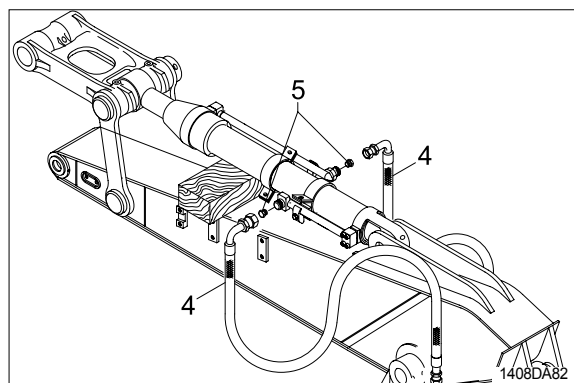
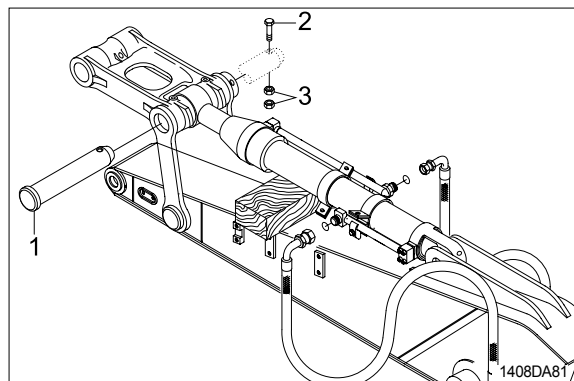
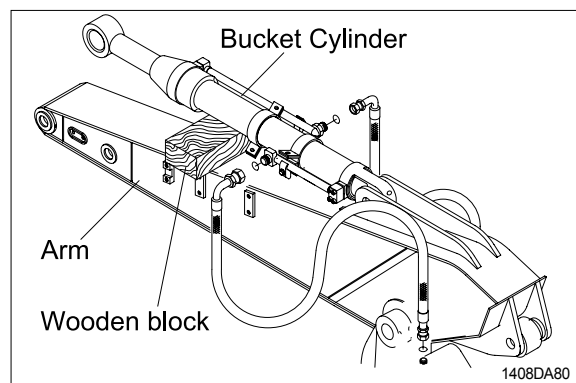

- ④ Sling bucket cylinder assembly(8) and remove bolt(6) then pull out pin (5).
- ⑤ Remove bucket cylinder assembly(8).
 - Weight : 90kg(200lb)

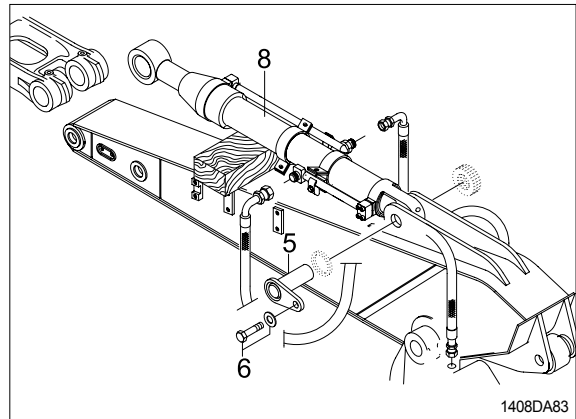

(2) Install

- ① Carry out installation in the reverse order to removal.

▲ When aligning the mounting position of the pin, do not insert your fingers in the pin hole.

- ※ Bleed the air from the bucket cylinder.
- ※ Confirm the hydraulic oil level and check the hydraulic oil leak or not.

2) ARM CYLINDER

(1) Removal

- ※ Expand the arm and bucket fully, lower the work equipment to the ground and stop the engine.
- ※ Operate the control levers and pedals several times to release the remaining pressure in the hydraulic piping.

▲ Loosen the breather slowly to release the pressure inside the hydraulic tank.

- ※ Escaping fluid under pressure can penetrate the skin causing serious injury. Fit blind plugs in the hoses after disconnecting them, to prevent dirt or dust from entering.

- ① Set block between arm cylinder and boom.

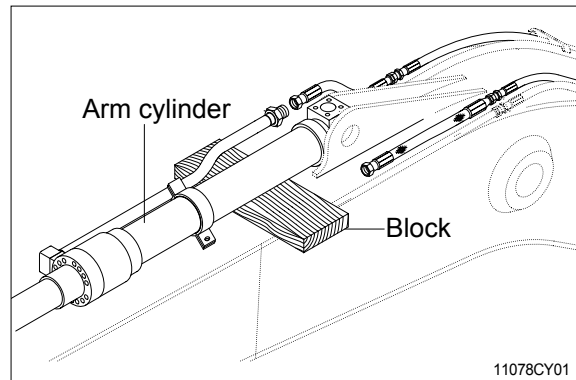

- ② Remove bolt(2) and pull out pin(1).

- ※ Tie the rod with wire to prevent it from coming out.

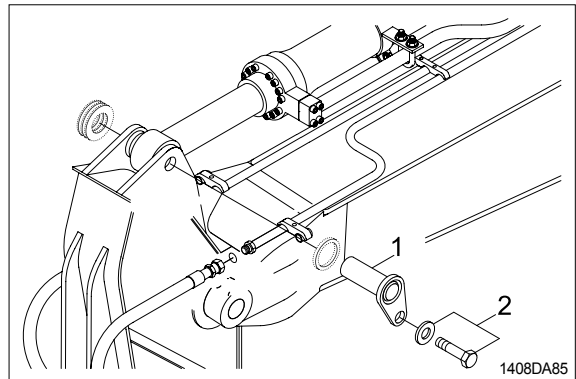

- ③ Disconnect arm cylinder hoses(3) and put plugs on cylinder pipe.

- ④ Disconnect greasing pipings(4).

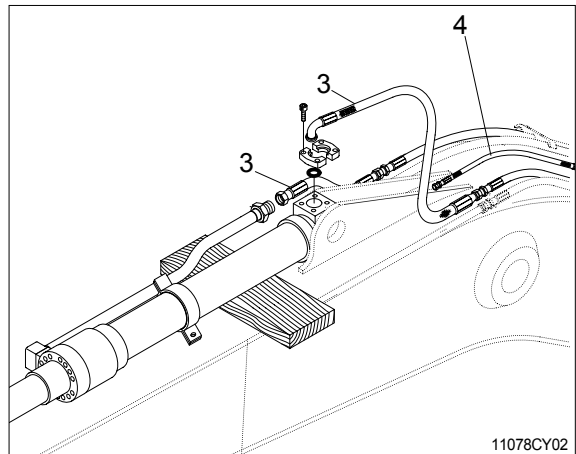

- ⑤ Sling arm assembly(7) and remove bolt (6) then pull out pin(5).
- ⑥ Remove arm cylinder assembly(7).
 - Weight : 140kg(310lb)

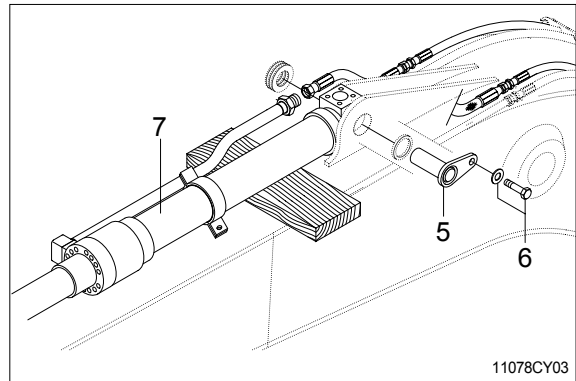

(2) Install

- ① Carry out installation in the reverse order to removal.

▲ When aligning the mounting position of the pin, do not insert your fingers in the pin hole.

- ※ Bleed the air from the arm cylinder.
- ※ Confirm the hydraulic oil level and check the hydraulic oil leak or not.

3) BOOM CYLINDER

(1) Removal

- ※ Expand the arm and bucket fully, lower the work equipment to the ground and stop the engine.
- ※ Operate the control levers and pedals several times to release the remaining pressure in the hydraulic piping.

▲ Loosen the breather slowly to release the pressure inside the hydraulic tank.

- ※ Escaping fluid under pressure can penetrate the skin causing serious injury. Fit blind plugs in the hoses after disconnecting them, to prevent dirt or dust from entering.

- ① Disconnect greasing hoses(1).
- ② Sling boom cylinder assembly.

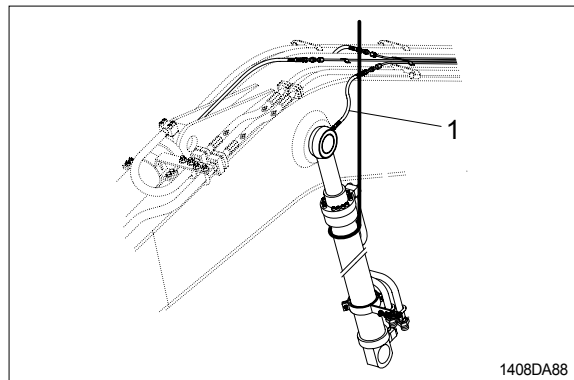

- ③ Remove bolt(4), stop plate(5) and pull out pin(2).
- ※ Tie the rod with wire to prevent it from coming out.

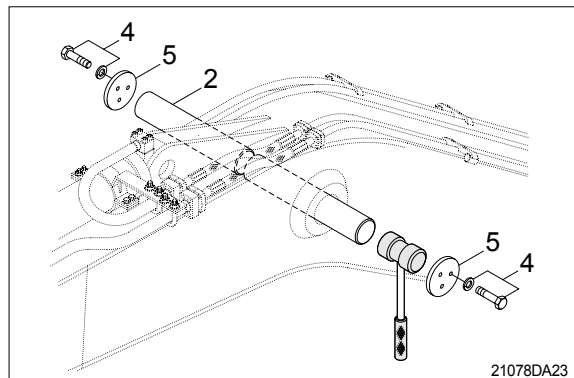

- ④ Lower the boom cylinder assembly(6) on a stand.

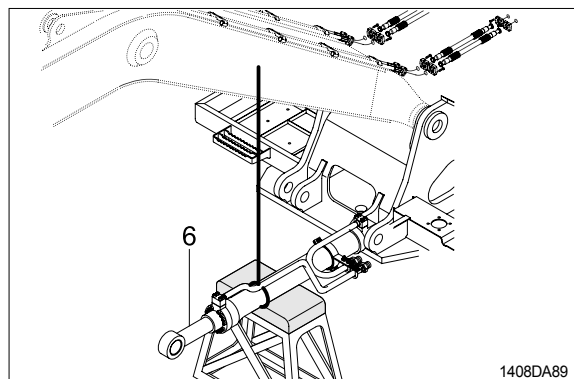

- ⑤ Disconnect boom cylinder hoses(7) and put plugs on cylinder pipe.

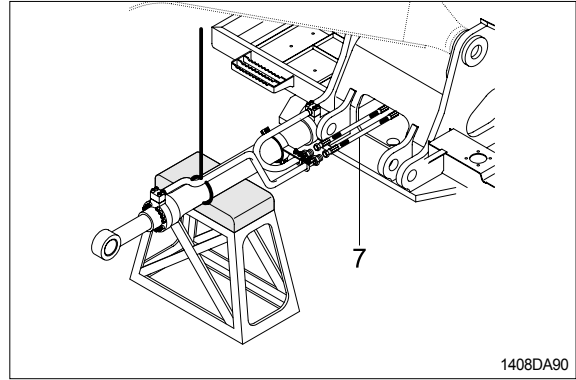

- ⑥ Remove bolt(9) and pull out pin(8).
⑦ Remove boom cylinder assembly(6).
· Weight : 115kg(255lb)

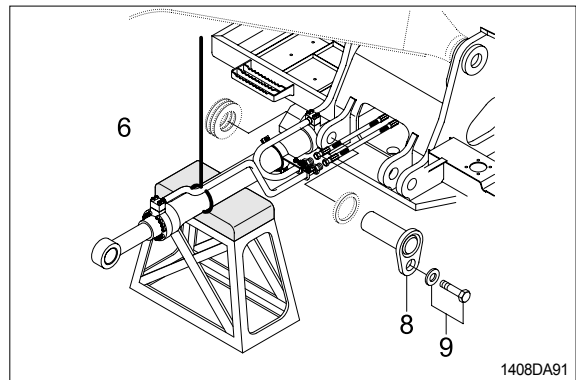

(2) Install

- ① Carry out installation in the reverse order to removal.

▲ When aligning the mounting position of the pin, do not insert your fingers in the pin hole.

- ※ Bleed the air from the boom cylinder.
- ※ Confirmed the hydraulic oil level and check the hydraulic oil leak or not.

2. DISASSEMBLY AND ASSEMBLY

1) STRUCTURE

(1) Bucket cylinder

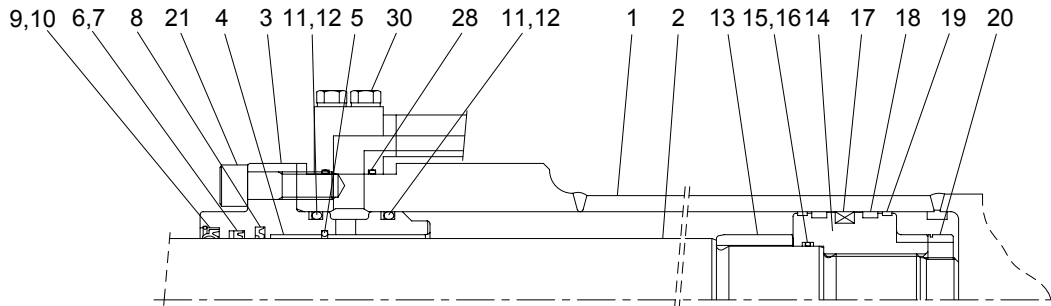

Internal detail

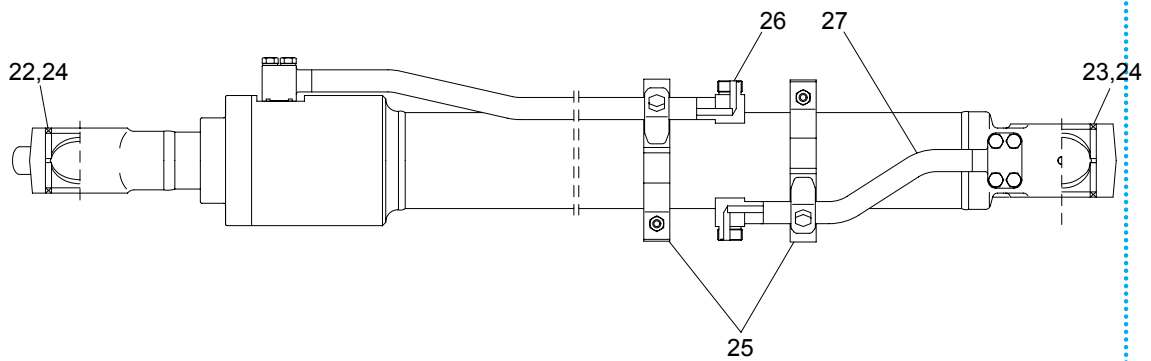

11078CY05

1	Tube assembly	11	O-ring	21	Hexagon socket head bolt
2	Rod assembly	12	Back up ring	22	Pin bush
3	Gland	13	Cushion ring	23	Pin bush
4	DD2 bush	14	Piston	24	Dust seal
5	Snap ring	15	O-ring	25	Band assembly
6	Rod seal	16	Back up ring	26	Pipe assembly(R)
7	Back up ring	17	Piston seal	27	Pipe assembly(B)
8	Buffer ring	18	Wear ring	28	O-ring
9	Dust wiper	19	Dust ring	29	O-ring
10	Snap ring	20	Lock nut	30	Hexagon socket head bolt

(2) Arm cylinder

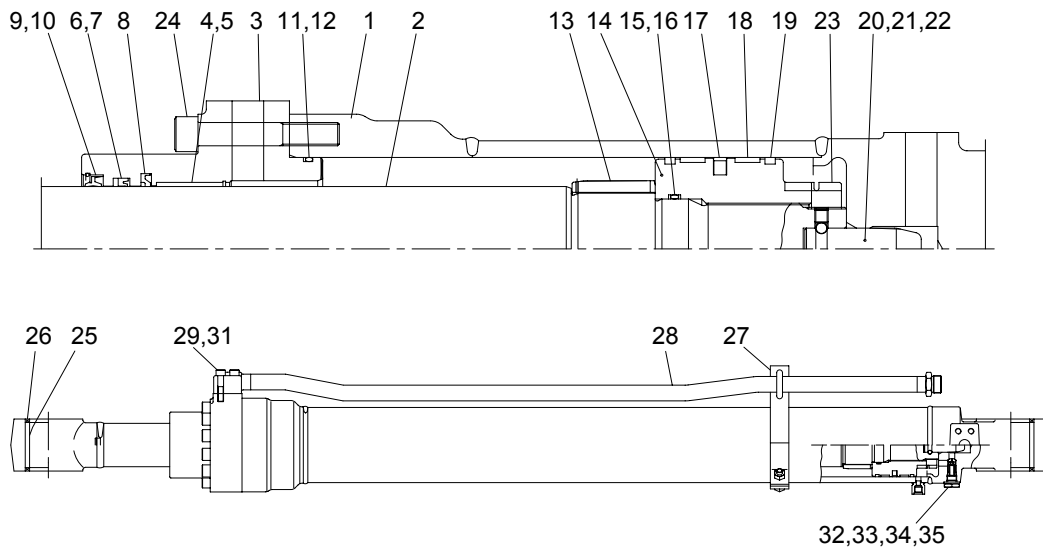

11078CY07

1	Tube assembly	13	Cushion ring	25	Pin bush
2	Rod assembly	14	Piston	26	Dust seal
3	Gland	15	O-ring	27	Band assembly
4	DD2 Bush	16	Back up ring	28	Pipe assembly(R)
5	Snap ring	17	Piston seal	29	O-ring
6	Rod seal	18	Wear ring	30	O-ring
7	Back up ring	19	Dust ring	31	Hexagon socket head bolt
8	Buffer ring	20	Cushion spear	32	Check valve
9	Dust wiper	21	Steel ball	33	Coil spring
10	Snap ring	22	Set screw	34	O-ring
11	O-ring	23	Lock nut	35	Plug
12	Back up ring	24	Hexagon socket head bolt		

(3) Boom cylinder

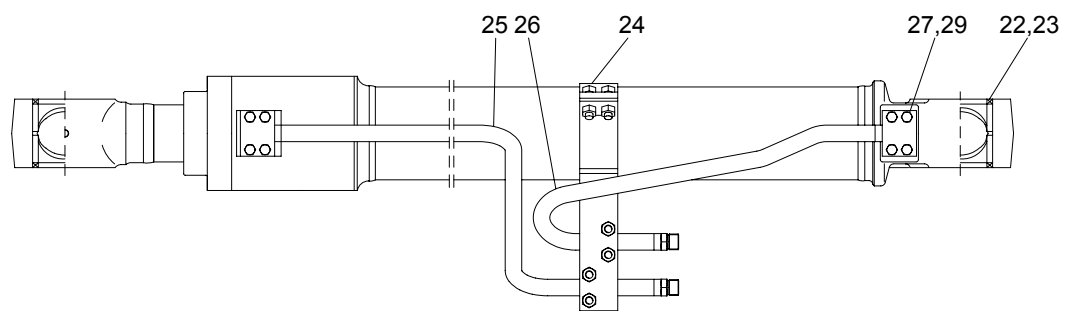
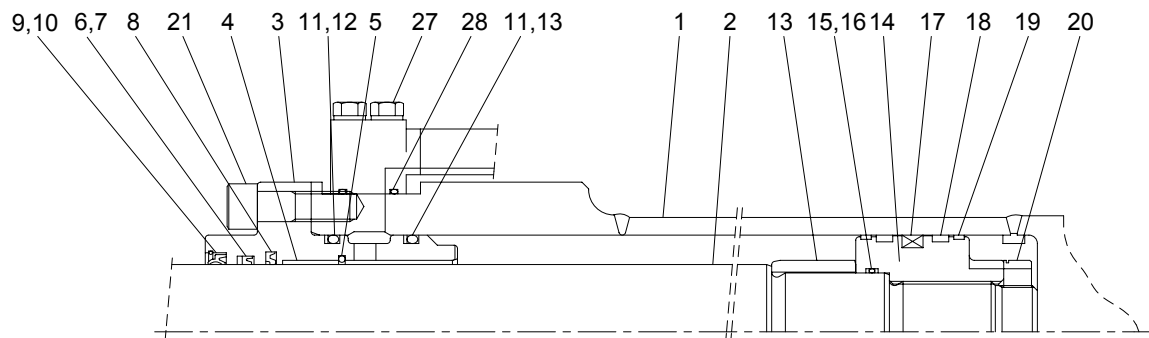

11078CY06

1	Tube assembly	11	O-ring	21	Hexagon socket head bolt
2	Rod assembly	12	Back up ring	22	Pin bush
3	Gland	13	Cushion ring	23	Dust seal
4	DD2 bush	14	Piston	24	Band assembly
5	Snapping	15	O-ring	25	Pipe assembly(R, LH/RH)
6	Rod seal	16	Back up ring	26	Pipe assembly(L, LH/RH)
7	Back up ring	17	Piston seal	27	O-ring
8	Buffer ring	18	Wear ring	28	O-ring
9	Dust wiper	19	Dust ring	29	Hexagon head bolt
10	Snap ring	20	Lock nut		

2) TOOLS AND TIGHTENING TORQUE

(1) Tools

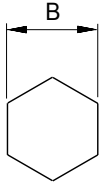
Tool name	B	Remark
Allen wrench	16	
	18	
Spanner	10	
	45	
	50	
	55	
(-) Driver	Small and large sizes	
Torque wrench	Capable of tightening with the specified torques	

(2) Tightening torque

Part name		Item	Size	Torque	
				kgf · m	lbf · ft
Gland mounting bolt (Socket head bolt)	Bucket cylinder	21	M12	9.4 ± 1	68.0 ± 7.2
	Boom cylinder	21	M12	9.4 ± 1	68.0 ± 7.2
	Arm cylinder	24	M14	15.0 ± 2.0	109 ± 14.5
Pipe mounting bolt (Hexagon head bolt)	Bucket cylinder	30	M10	5.4 ± 0.5	39.1 ± 3.6
	Boom cylinder	29	M 8	2.7 ± 0.3	19.6 ± 1.8
	Arm cylinder	31	M10	5.4 ± 0.5	39.1 ± 3.6
Lock nut	Bucket cylinder	20	M40	100 ± 10.0	723 ± 72.3
	Boom cylinder	20	M40	100 ± 10.0	723 ± 72.3
	Arm cylinder	23	M50	100 ± 10.0	723 ± 72.3
Piston	Bucket cylinder	14	M45	150 ± 15.0	1085 ± 109
	Boom cylinder	15	M45	150 ± 15.0	1085 ± 109
	Arm cylinder	14	M55	150 ± 15.0	1085 ± 109

3) DISASSEMBLY

(1) Remove cylinder head and piston rod

※ Procedures are based on the bucket cylinder.

① Hold the clevis section of the tube in a vise.

※ Use mouth pieces so as not to damage the machined surface of the cylinder tube. Do not make use of the outside piping as a locking means.

② Pull out rod assembly(2) about 200mm (7.1in). Because the rod assembly is rather heavy, finish extending it with air pressure after the oil draining operation.

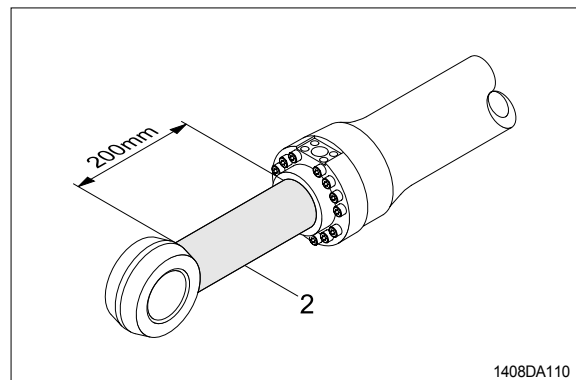

③ Loosen and remove socket bolts(21) of the gland in sequence.

※ Cover the extracted rod assembly(2) with rag to prevent it from being accidentally damaged during operation.

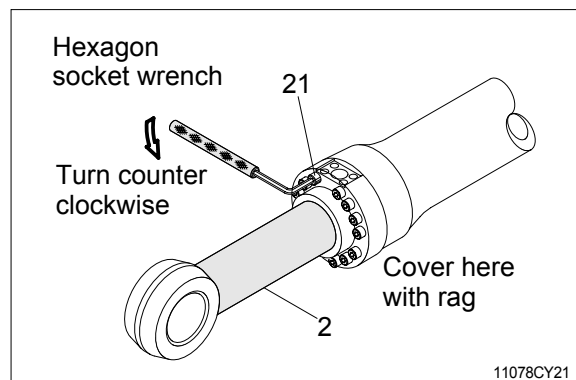

④ Draw out cylinder head and rod assembly together from tube assembly(1).

※ Since the rod assembly is heavy in this case, lift the tip of the rod assembly(2) with a crane or some means and draw it out. However, when rod assembly(2) has been drawn out to approximately two thirds of its length, lift it in its center to draw it completely.

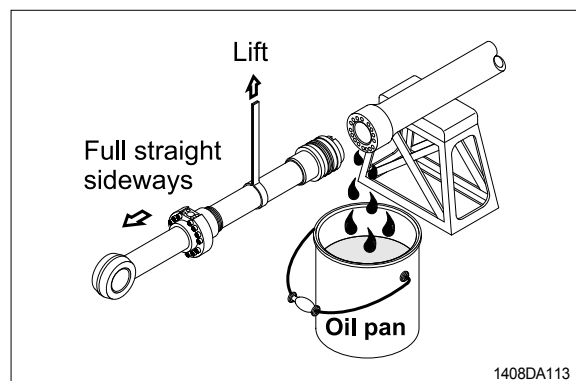

Note that the plated surface of rod assembly(2) is to be lifted. For this reason, do not use a wire sling and others that may damage it, but use a strong cloth belt or a rope.

- ⑤ Place the removed rod assembly on a wooden V-block that is set level.
- ※ Cover a V-block with soft rag.

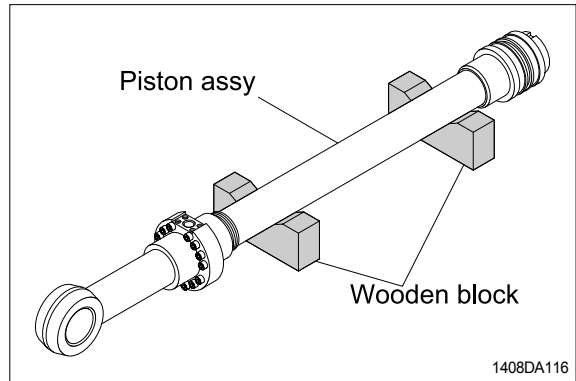

(2) Remove piston and cylinder head

- ① Remove lock nut(20).
- ※ Since lock nut(20) is tightened to a high torque, use a hydraulic and power wrench that utilizes a hydraulic cylinder, to remove the lock nut(20).
- ② Remove piston assembly(14), back up ring(16), and O-ring(15).

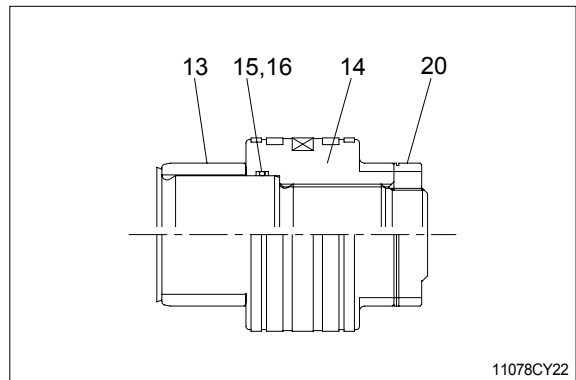

- ③ Remove the cylinder head assembly from rod assembly(2).
 - ※ If it is too heavy to move, move it by striking the flanged part of cylinder head with a plastic hammer.
 - ※ Pull it straight with cylinder head assembly lifted with a crane.
- Exercise care so as not to damage the lip of rod bushing(4) and packing (5,6,7,8,9,10) by the threads of rod assembly(2).

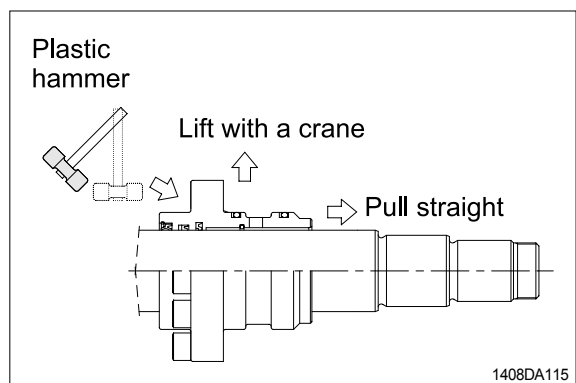

(3) Disassemble the piston assembly

- ① Remove wear ring(18).
 - ② Remove dust ring(19) and piston seal (17).
- ※ Exercise care in this operation not to damage the grooves.

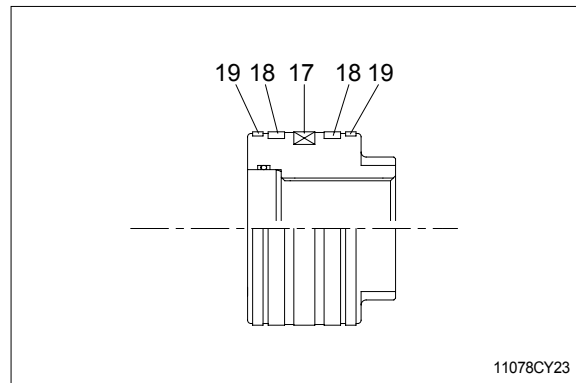

(4) Disassemble cylinder head assembly

- ① Remove back up ring(11) and O-ring (12).
 - ② Remove snap ring(10), dust wiper(9).
 - ③ Remove back up ring(7), rod seal(6) and buffer ring(8).
- ※ Exercise care in this operation not to damage the grooves.
- ※ Do not remove seal and ring, if does not damaged.

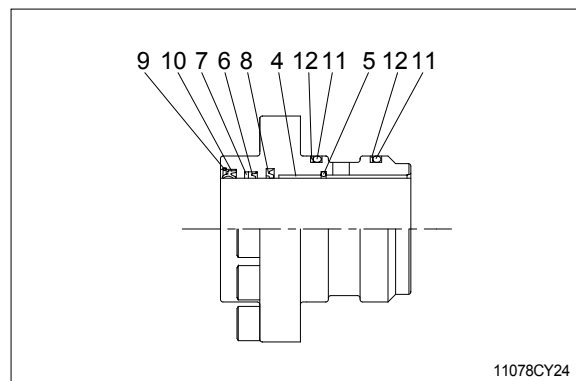

3) ASSEMBLY

(1) Assemble cylinder head assembly

※ Check for scratches or rough surfaces if found smooth with an oil stone.

- ① Coat the inner face of gland(3) with hydraulic oil.

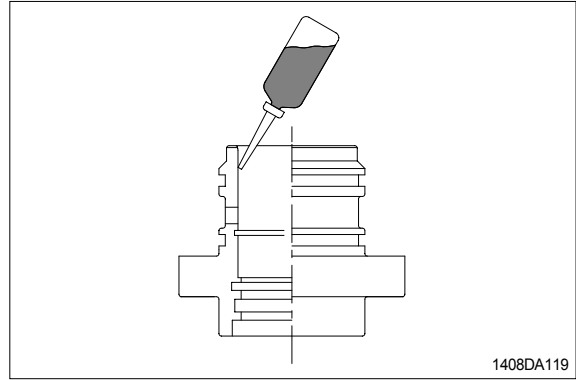

- ② Coat dust wiper(9) with grease and fit dust wiper(9) to the bottom of the hole of dust seal.

At this time, press a pad metal to the metal ring of dust seal.

- ③ Fit snap ring(10) to the stop face.

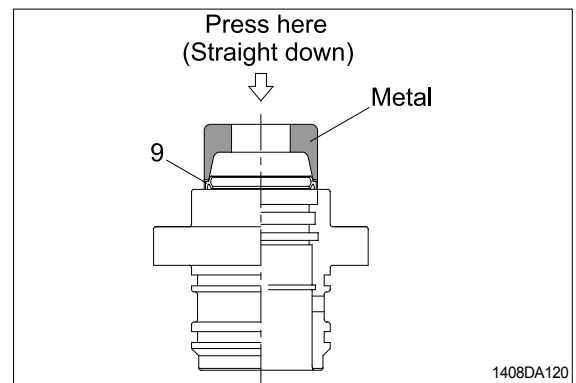

- ④ Fit back up ring(7), rod seal(6) and buffer ring(8) to corresponding grooves, in that order.

※ Coat each packing with hydraulic oil before fitting it.

※ Insert the backup ring until one side of it is inserted into groove.

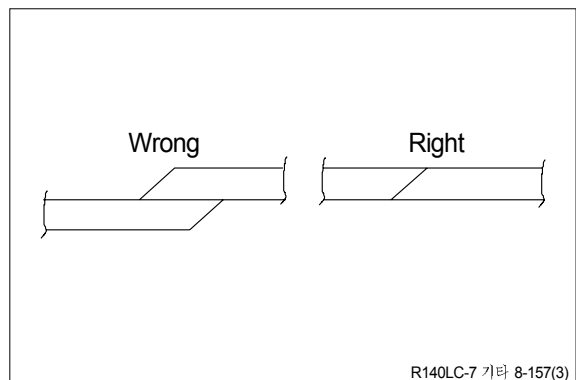

※ Rod seal(6) has its own fitting direction. Therefore, confirm it before fitting them.

※ Fitting rod seal(6) upside down may damage its lip. Therefore check the correct direction that is shown in fig.

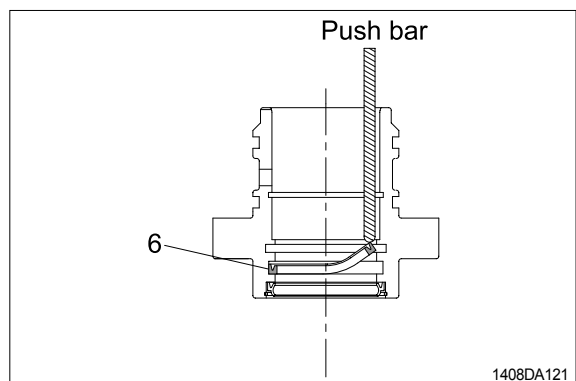

- ⑤ Fit back up ring(12) to gland(3).
- ※ Put the backup ring in the warm water of 30~50°C.
- ⑥ Fit O-ring(11) to gland(3).

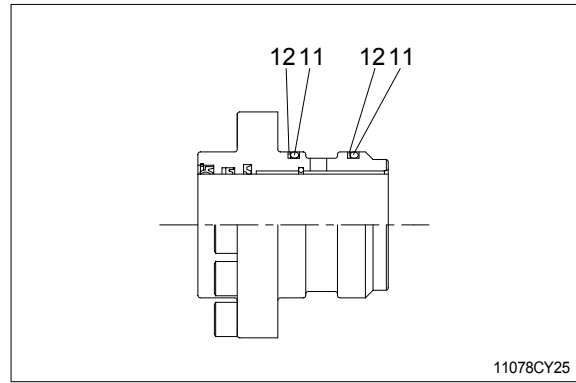

(2) Assemble piston assembly

- ※ Check for scratches or rough surfaces.
If found smooth with an oil stone.
- ① Coat the outer face of piston(14) with hydraulic oil.

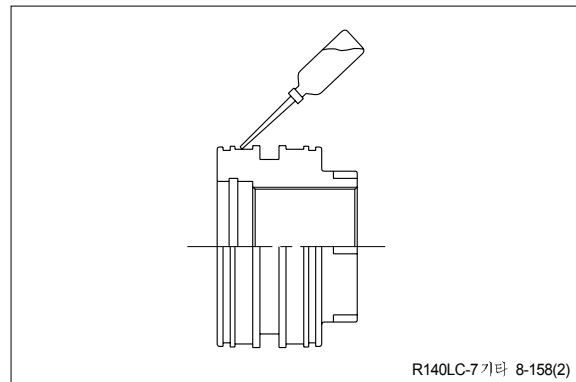

- ② Fit piston seal(17) to piston.
- ※ Put the piston seal in the warm water of 60~100°C for more than 5 minutes.
- ※ After assembling the piston seal, press its outer diameter to fit in.

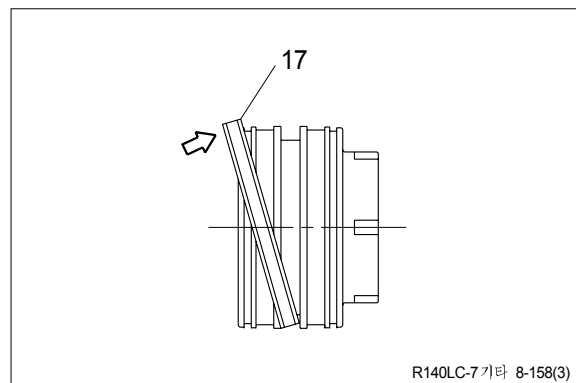

- ③ Fit wear ring(18) and dust ring(19) to piston(14).

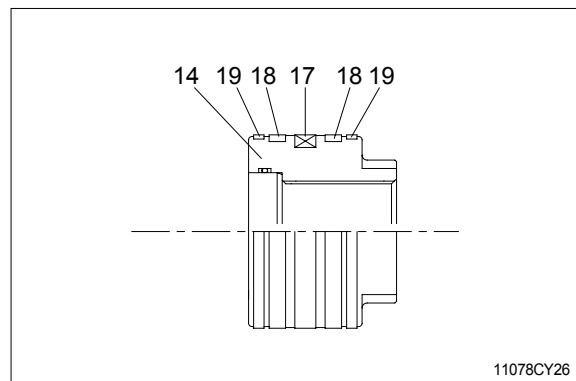

(3) Install piston and cylinder head

- ① Fix the rod assembly to the work bench.
- ② Apply hydraulic oil to the outer surface of rod assembly(2), the inner surface of piston and cylinder head.
- ③ Insert cylinder head assembly to rod assembly.

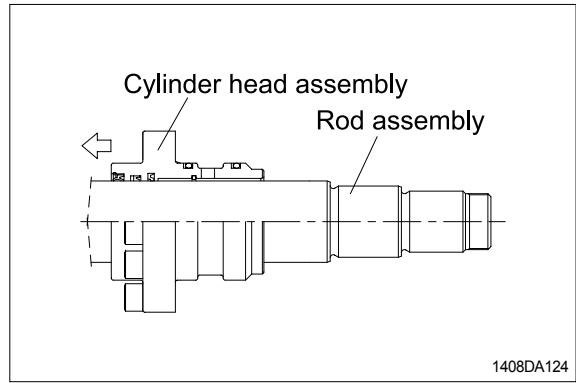

- ④ Insert cushion ring(13) to rod assembly.
- ※ Note that cushion ring(13) has a direction in which it should be fitted.

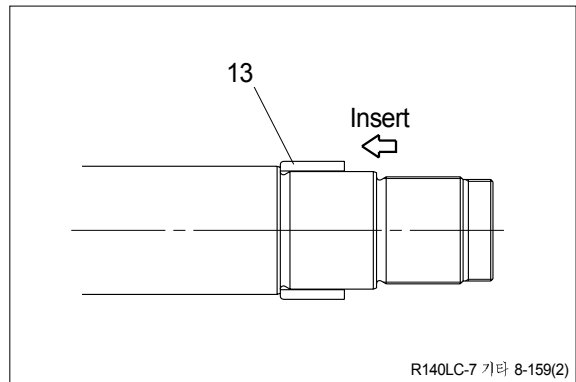

- ⑤ Fit piston assembly to rod assembly.
- Tightening torque : $150 \pm 15 \text{ kgf} \cdot \text{m}$
($1085 \pm 109 \text{ lbf} \cdot \text{ft}$)

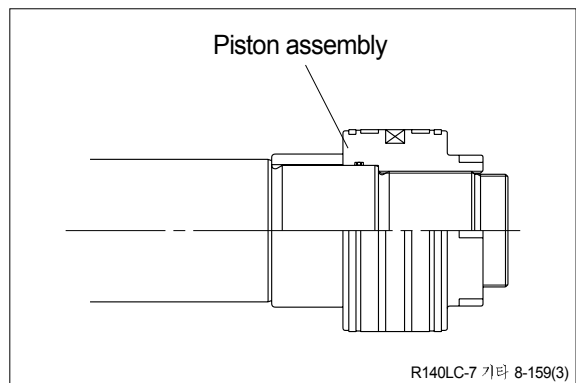

- ⑥ Fit lock nut(20) to piston.
- Tightening torque :

Item		kgf · m	lbf · ft
Bucket	20	100 ± 10	723 ± 72.3
Boom	20	100 ± 10	723 ± 72.3
Arm	23	100 ± 10	723 ± 72.3

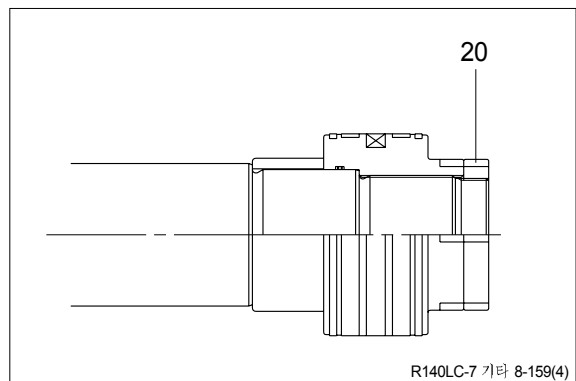

(3) Overall assemble

- ① Place a V-block on a rigid work bench.
Mount the tube assembly(1) on it and fix the assembly by passing a bar through the clevis pin hole to lock the assembly.
- ② Insert the rod assembly in to the tube assembly, while lifting and moving the rod assembly with a crane.
 - ※ Be careful not to damage piston seal by thread of tube assembly.
- ③ Match the bolt holes in the cylinder head flange to the tapped holes in the tube assembly and tighten socket bolts to a specified torque.
 - ※ Refer to the table of tightening torque.

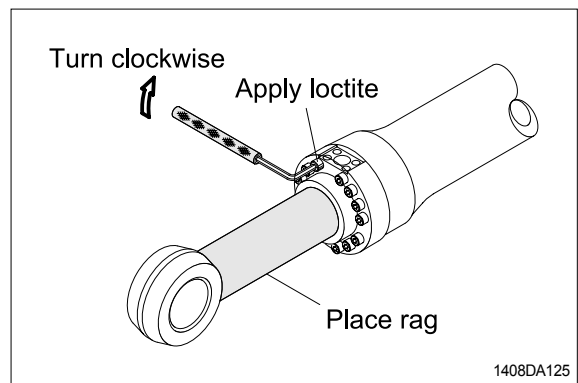
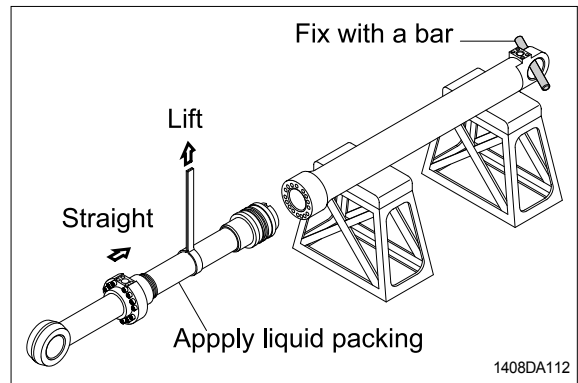

GROUP 10 UNDERCARRIAGE

1. TRACK LINK

1) REMOVAL

- (1) Move track link until master pin is over front idler in the position put wooden block as shown.
- (2) Loosen tension of the track link.
 - ※ If track tension is not relieved when the grease valve is loosened, move the machine backwards and forwards.
- (3) Push out master pin by using a suitable tool.

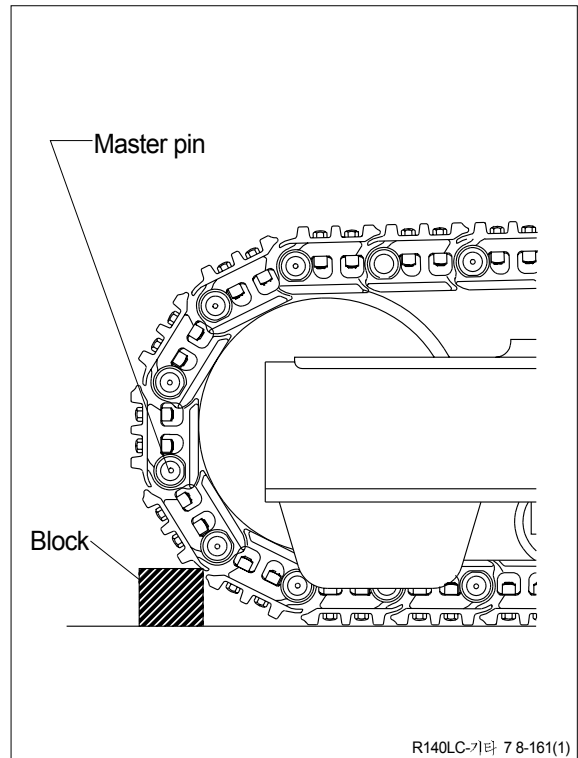

- (4) Move the machine slowly in reverse, and lay out track link assembly (1).
 - ※ Jack up the machine and put wooden block under the machine.
 - ※ Don't get close to the sprocket side as the track shoe plate may fall down on your feet.

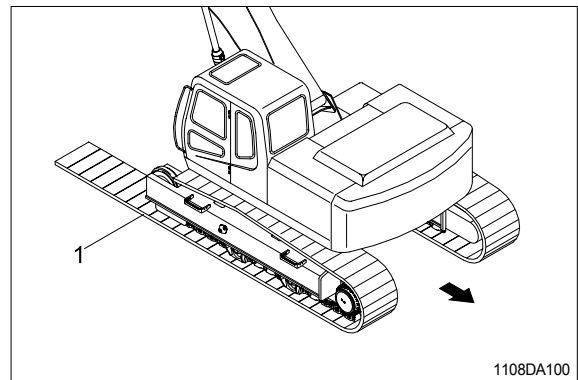

2) INSTALL

- (1) Carry out installation in the reverse order to removal.
 - ※ Adjust the tension of the track link.

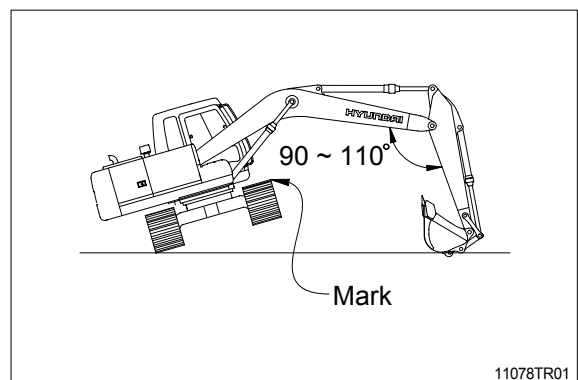

2. CARRIER ROLLER

1) REMOVAL

- (1) Loosen tension of the track link.

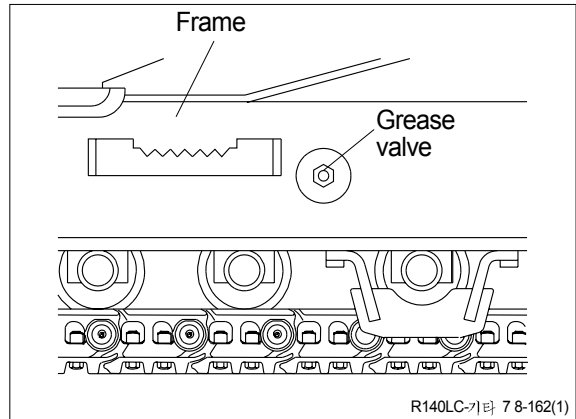

- (2) Jack up the track link height enough to permit carrier roller removal.

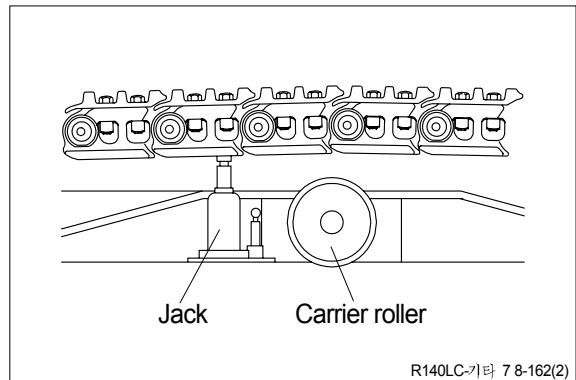

- (3) Loosen the lock nut (1).
- (4) Open bracket(2) with a screwdriver, push out from inside, and remove carrier roller assembly.
 - Weight : 13kg(29lb)

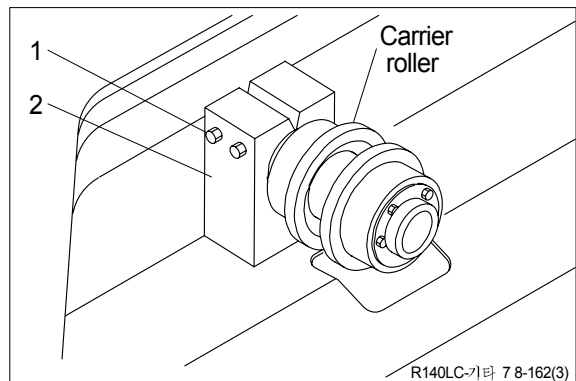

2) INSTALL

- (1) Carry out installation in the reverse order to removal.

3. TRACK ROLLER

1) REMOVAL

- (1) Loosen tension of the track link.

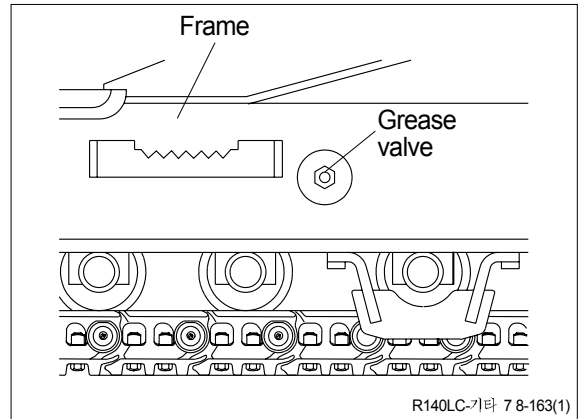

- (2) Using the work equipment, push up track frame on side which is to be removed.

※ After jack up the machine, set a block under the unit.

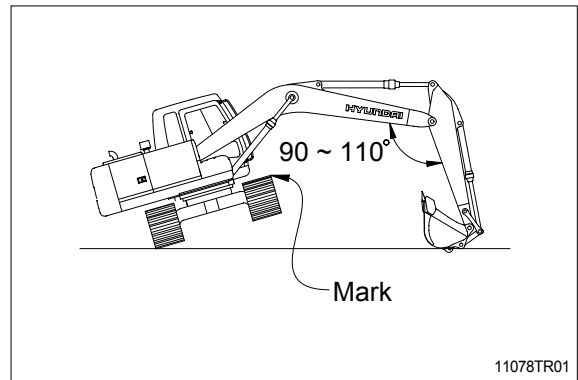

- (3) Remove the mounting bolt(1) and draw out the track roller(2).

· Weight : 24.6kg(54.2lb)

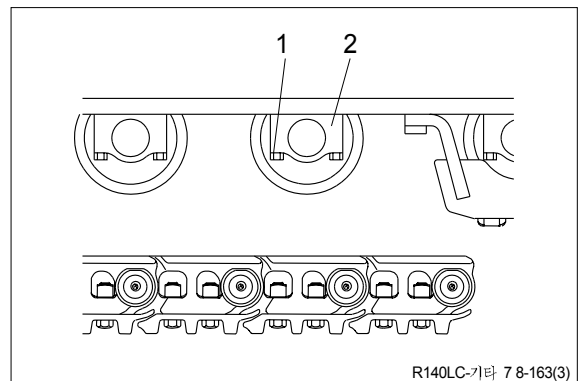

2) INSTALL

- (1) Carry out installation in the reverse order to removal.

4. IDLER AND RECOIL SPRING

1) REMOVAL

- (1) Remove the track link.
For detail, see **removal of track link**.

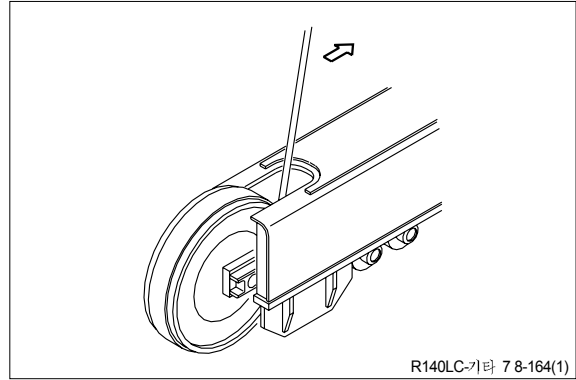

- (2) Sling the recoil spring(1) and pull out idler and recoil spring assembly from track frame, using a pry.
· Weight : 215kg(474lb)

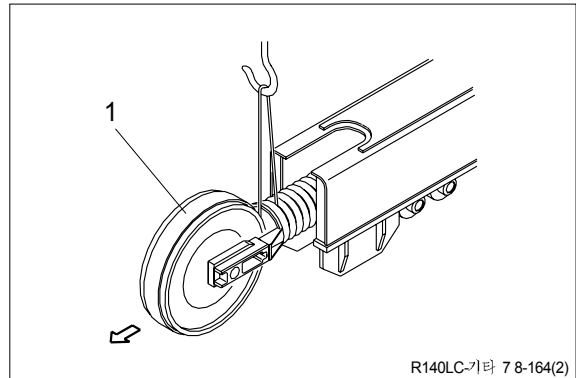

- (3) Remove the bolts(2), washers(3) and separate idler from recoil spring.

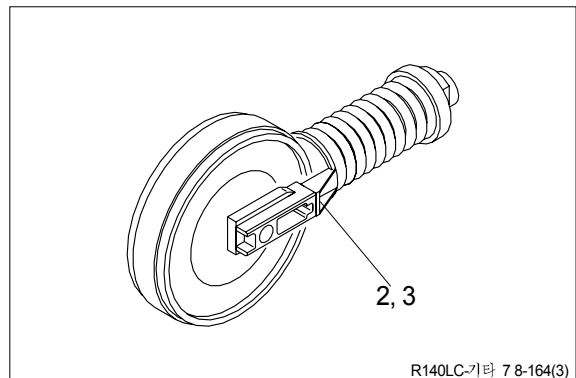

2) INSTALL

- (1) Carry out installation in the reverse order to removal.
※ Make sure that the boss on the end face of the recoil cylinder rod is in the hole of the track frame.

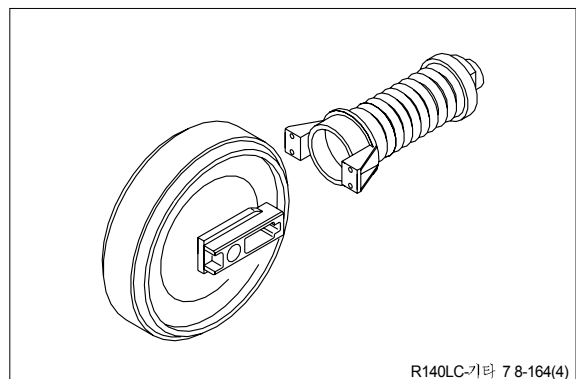

3) DISASSEMBLY AND ASSEMBLY OF IDLER

(1) Structure

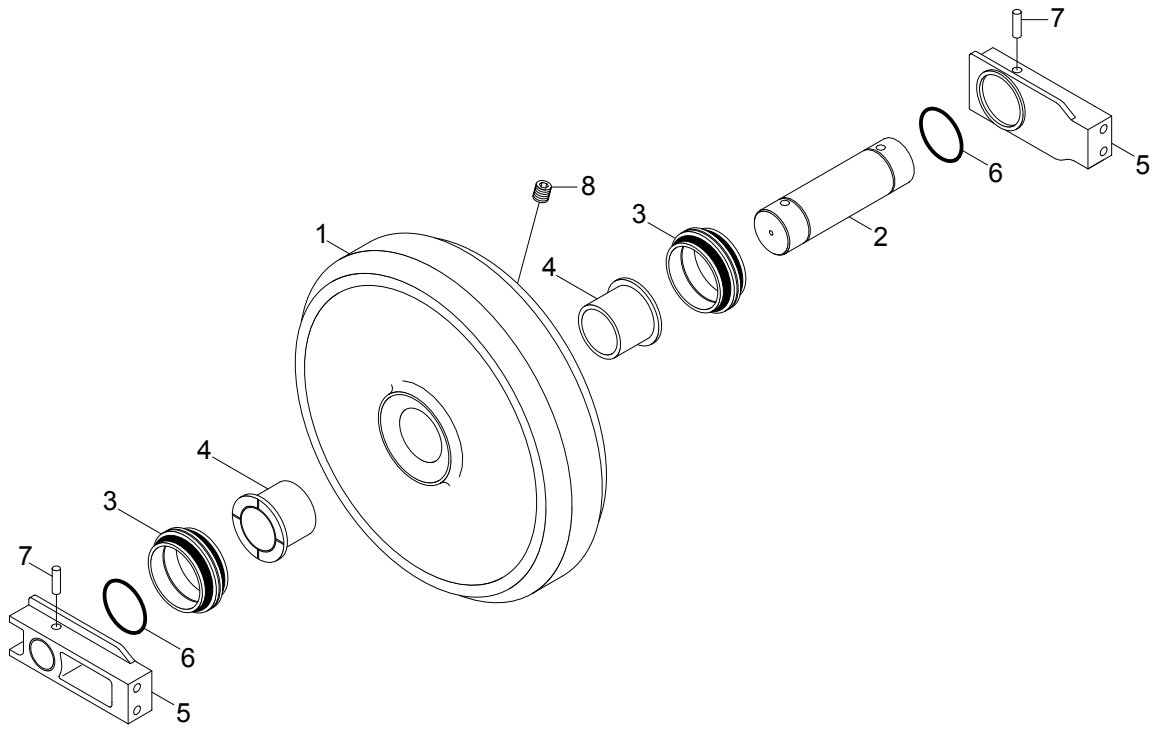

21078DA43

- 1 Shell
- 2 Shaft
- 3 Seal assembly

- 4 Bushing
- 5 Bracket
- 6 O-ring

- 7 Spring pin
- 8 Plug

(2) Disassembly

- ① Remove plug and drain oil.
- ② Draw out the spring pin(7), using a press.

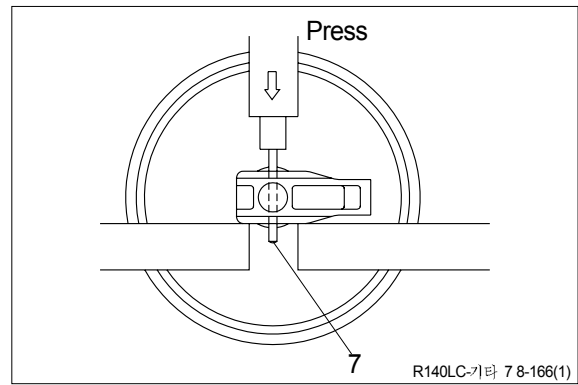

- ③ Pull out the shaft(2) with a press.
- ④ Remove seal(3) from idler(1) and bracket (5).
- ⑤ Remove O-ring(6) from shaft.

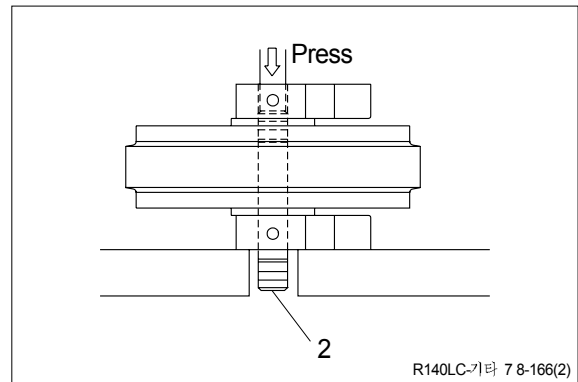

- ⑥ Remove the bushing(4) from idler, using a special tool.
- ※ Only remove bushing if replacement is necessary.

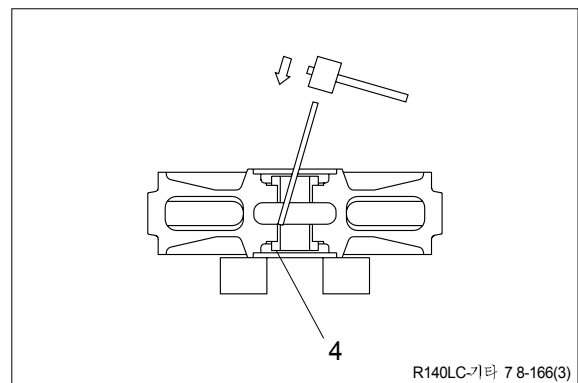

(3) Assembly

- ※ Before assembly, clean the parts.
- ※ Coat the sliding surfaces of all parts with oil.

① Cool up bushing(4) fully by some dry ice and press it into shell(1).

Do not press it at the normal temperature, or not knock in with a hammer even after the cooling.

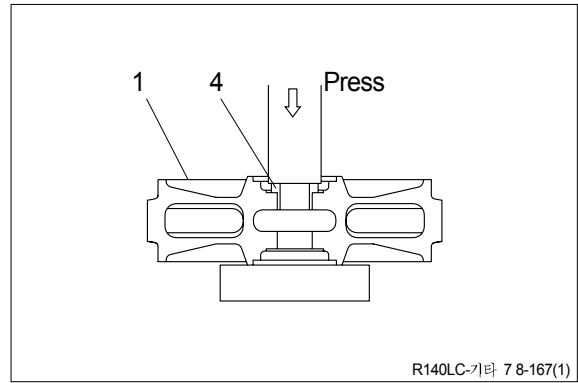

② Coat O-ring(6) with grease thinly, and install it to shaft(2).

③ Insert shaft(2) into bracket(5) and drive in the spring pin(7).

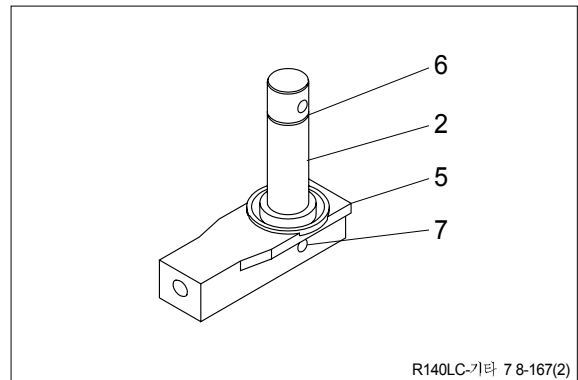

④ Install seal(3) to shell(1) and bracket(5).

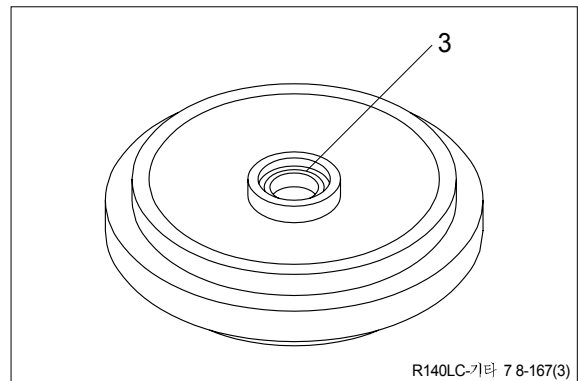

⑤ Install shaft(2) to shell(1).

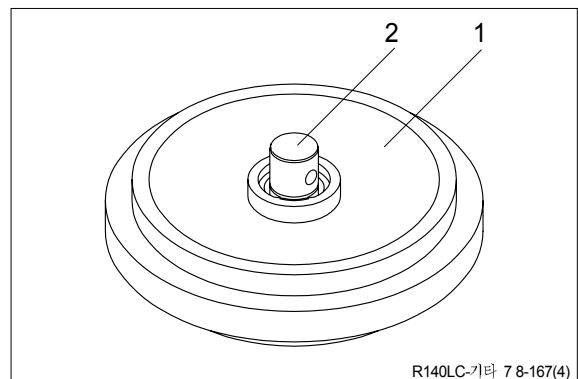

⑥ Install bracket(5) attached with seal(3).

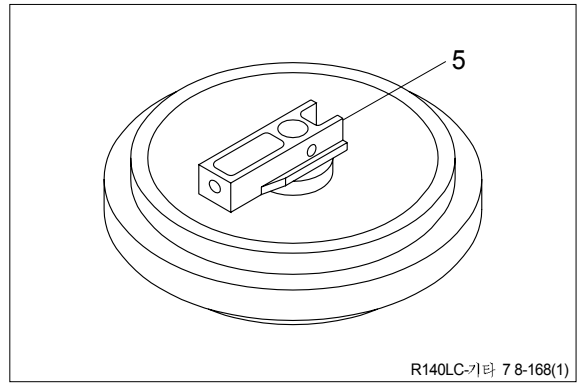

⑦ Knock in the spring pin(7) with a hammer.

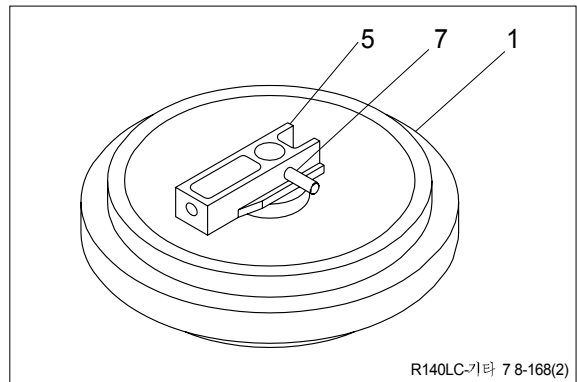

⑧ Lay bracket(5) on its side.
Supply engine oil to the specified level,
and tighten plug.

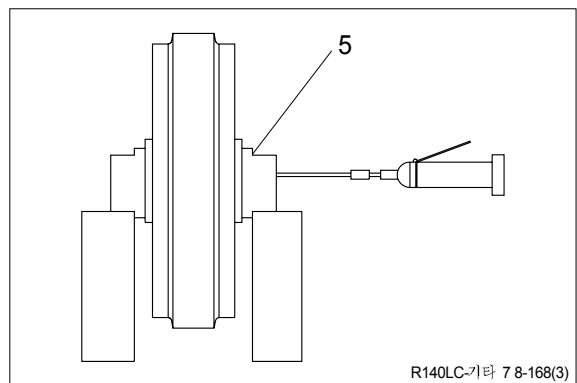

4) DISASSEMBLY AND ASSEMBLY OF RECOIL SPRING

(1) Structure

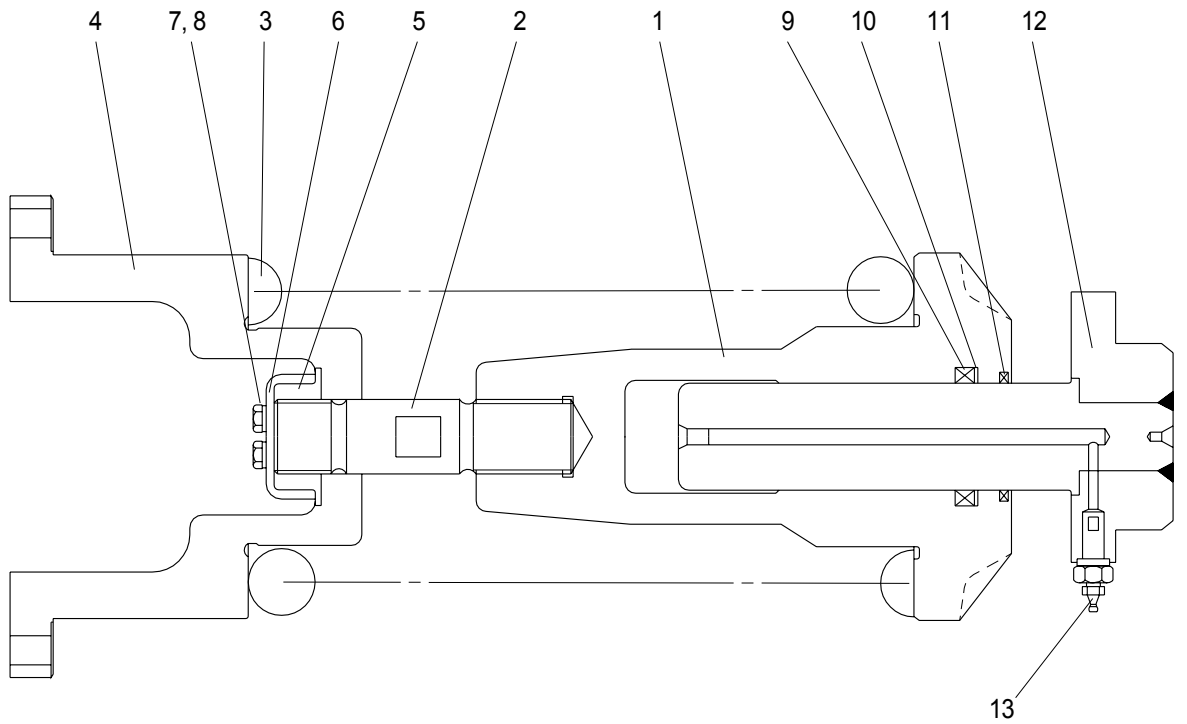

R210UCG1

- | | | | | | |
|---|----------|----|---------------|----|--------------|
| 1 | Body | 6 | Lock plate | 11 | Dust seal |
| 2 | Tie bar | 7 | Bolt | 12 | Rod assembly |
| 3 | Spring | 8 | Spring washer | 13 | Grease valve |
| 4 | Bracket | 9 | Rod seal | | |
| 5 | Lock nut | 10 | Back up ring | | |

(2) Disassembly

- ① Apply pressure on spring(3) with a press.
 - ※ The spring is under a large installed load. This is dangerous, so be sure to set properly.
 - Spring set load : 8497kg(18733lb)
- ② Remove bolt(7), spring washer(8) and lock plate(6).
- ③ Remove lock nut(5).

Take enough notice so that the press which pushes down the spring, should not be slipped out in its operation.
- ④ Lighten the press load slowly and remove bracket(4) and spring(3).

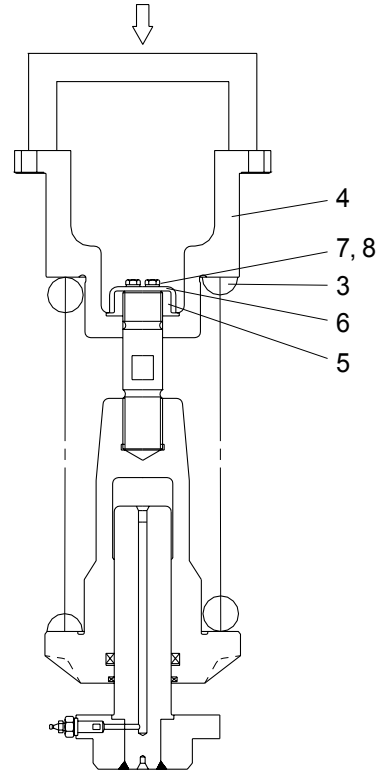

R210UCG2(1)

- ⑤ Remove rod(12) from body(1).
- ⑥ Remove grease valve(13) from rod(12).

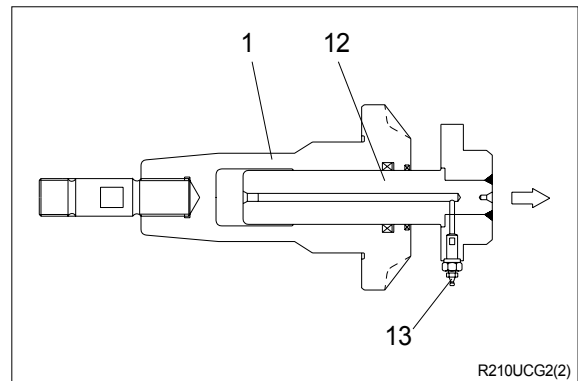

R210UCG2(2)

- ⑦ Remove rod seal(9), back up ring(10) and dust seal(11).

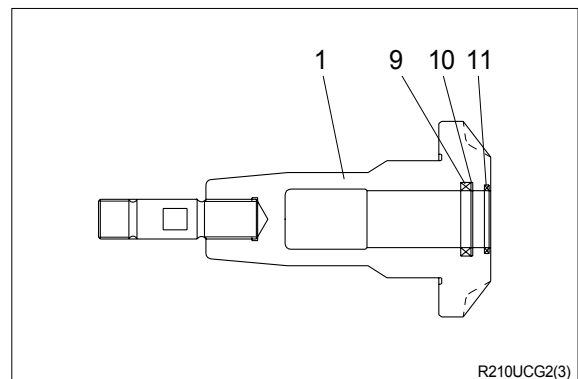

R210UCG2(3)

(3) Assembly

- ① Install dust seal(11), back up ring(10) and rod seal(9) to body(1).
- ※ When installing dust seal(11) and rod seal(9), take full care so as not to damage the lip.

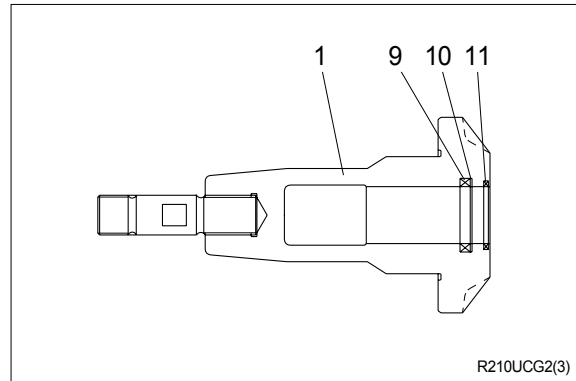

- ② Pour grease into body(1), then push in rod(12) by hand.
After take grease out of grease valve mounting hole, let air out.
- ※ If air letting is not sufficient, it may be difficult to adjust the tension of crawler.
- ③ Fit grease valve(13) to rod(12).
 - Tightening torque : $10 \pm 1 \text{ kg} \cdot \text{m}$
($72.4 \pm 7.2 \text{ lb} \cdot \text{ft}$)

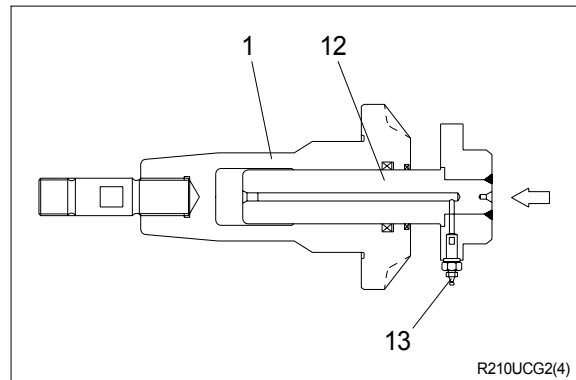

- ④ Install spring(3) and bracket(4) to body (1).
- ⑤ Apply pressure to spring(3) with a press and tighten lock nut(5).
- ※ Apply sealant before assembling.
- ※ During the operation, pay attention specially to prevent the press from slipping out.

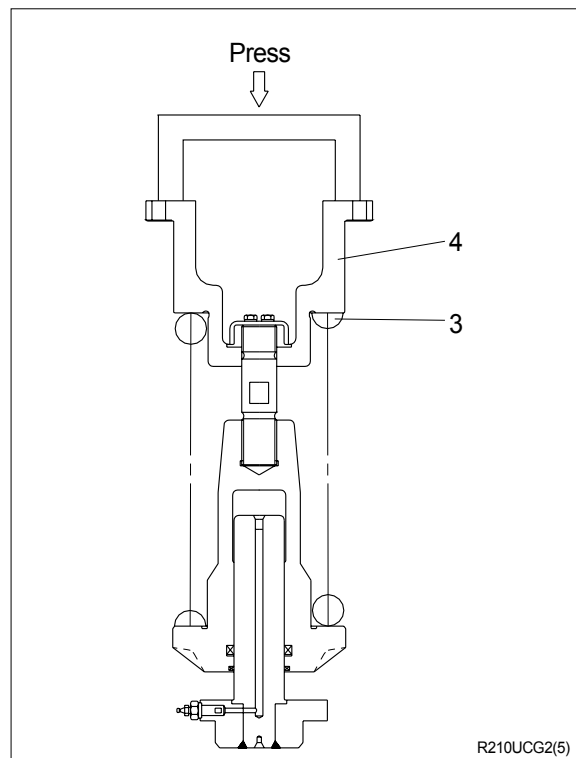

- ⑥ Lighten the press load and confirm the set length of spring(3).
- ⑦ After the setting of spring(3), install lock plate(6), spring washer(8) and bolt(7).

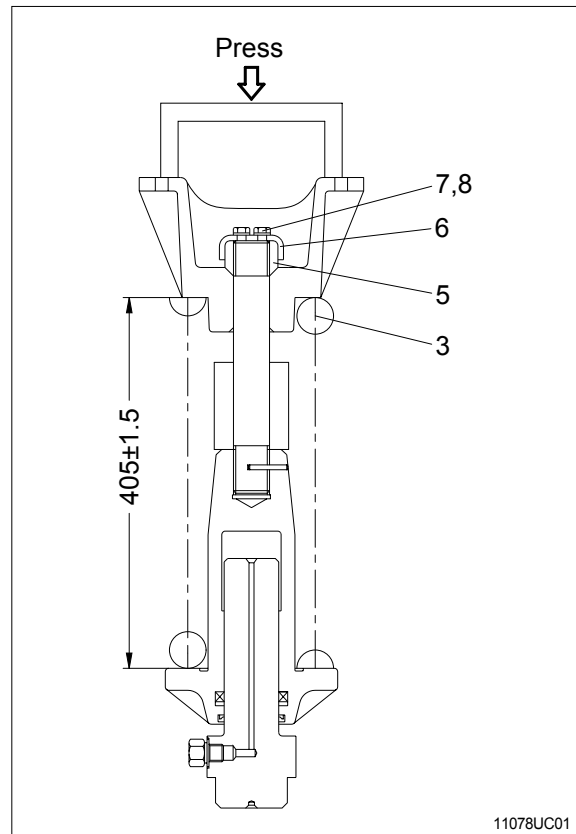

11078UC01

GROUP 11 WORK EQUIPMENT

1. STRUCTURE

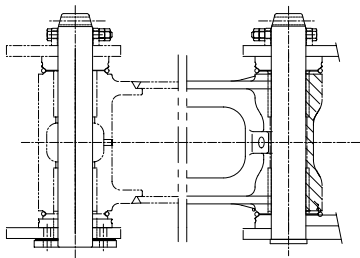
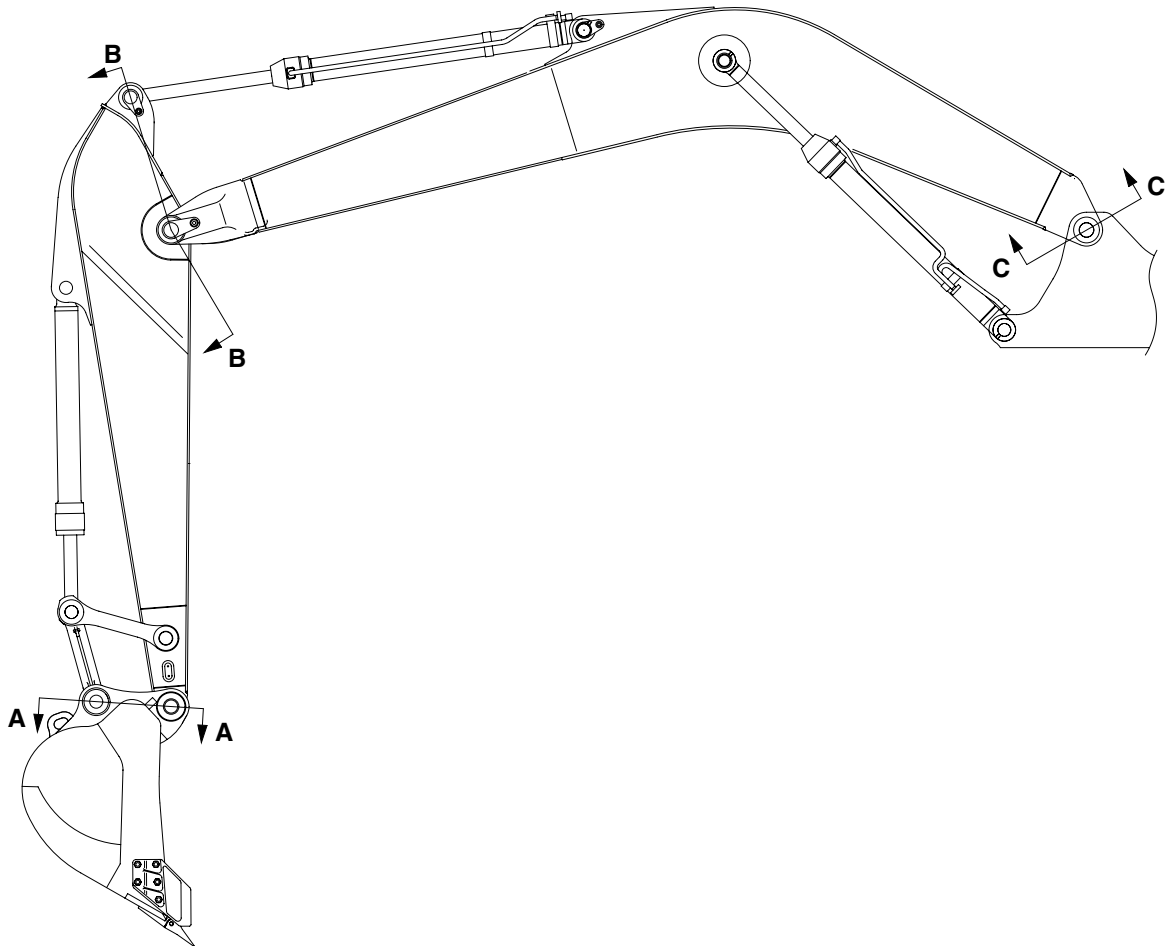

SECTION A

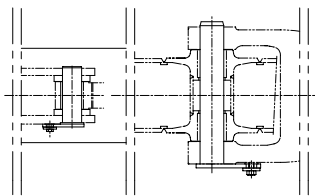

SECTION B

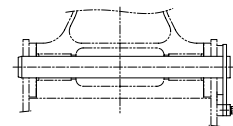

SECTION C

21078DA44

2. REMOVAL AND INSTALL

1) BUCKET ASSEMBLY

(1) Removal

- ① Lower the work equipment completely to ground with back of bucket facing down.

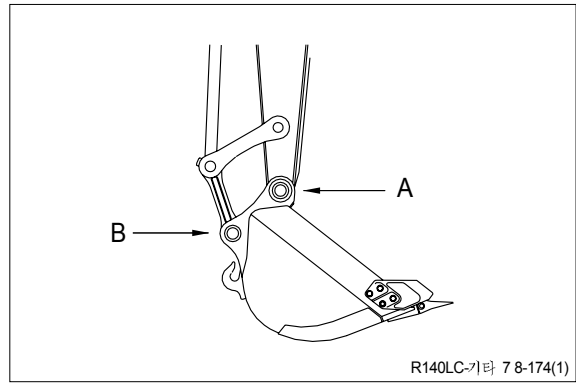

- ② Remove nut(1), bolt(2) and draw out the pin(A).

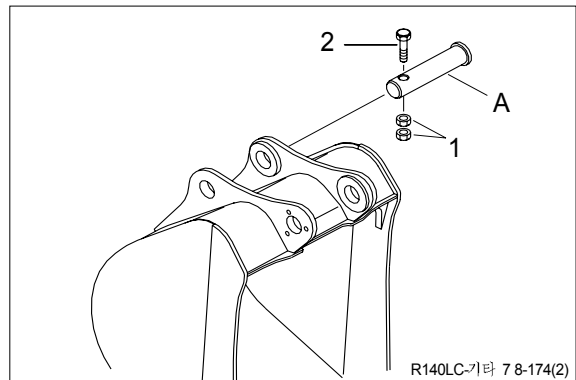

- ③ Remove nut(3), bolt(4) and draw out the pin(B).

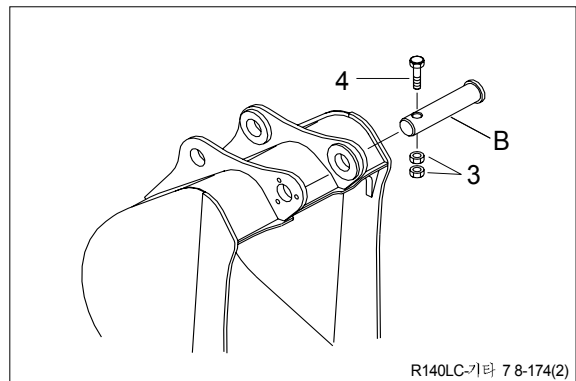

(2) Install

- ① Carry out installation in the reverse order to removal.

▲ When aligning the mounting position of the pin, do not insert your fingers in the pin hole.

※ Adjust the bucket clearance.
For detail, see **operation manual**.

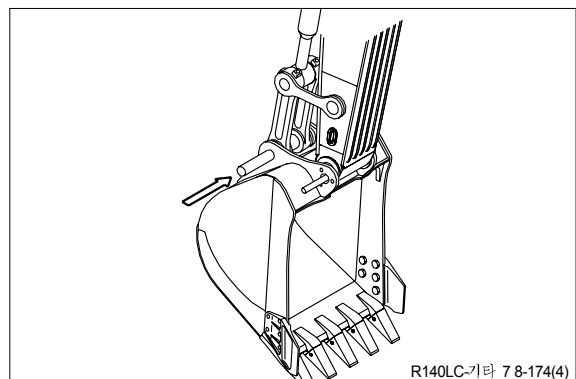

2) ARM ASSEMBLY

(1) Removal

- ※ Loosen the breather slowly to release the pressure inside the hydraulic tank.

▲ Escaping fluid under pressure can penetrate the skin causing serious injury.

- ① Remove bucket assembly.
For details, see **removal of bucket assembly**.

- ② Disconnect bucket cylinder hose(1).

▲ Fit blind plugs(5) in the piping at the chassis end securely to prevent oil from spurting out when the engine is started.

- ③ Sling arm cylinder assembly, remove spring, pin stopper and pull out pin.
※ Tie the rod with wire to prevent it from coming out.

- ④ For details, see **removal of arm cylinder assembly**.

Place a wooden block under the cylinder and bring the cylinder down to it.

- ⑤ Remove bolt(2), plate(3) and pull out the pin(4) then remove the arm assembly.
· Weight : 950kg(2090lb)

- ※ When lifting the arm assembly, always lift the center of gravity.

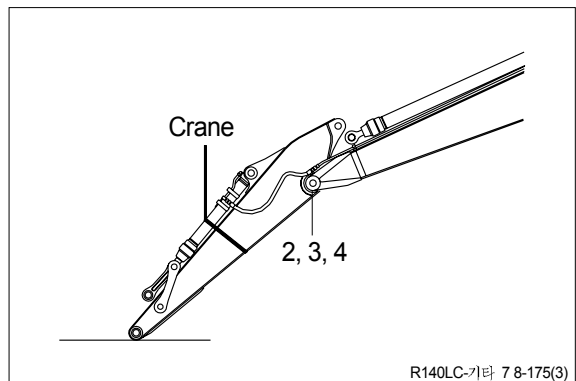
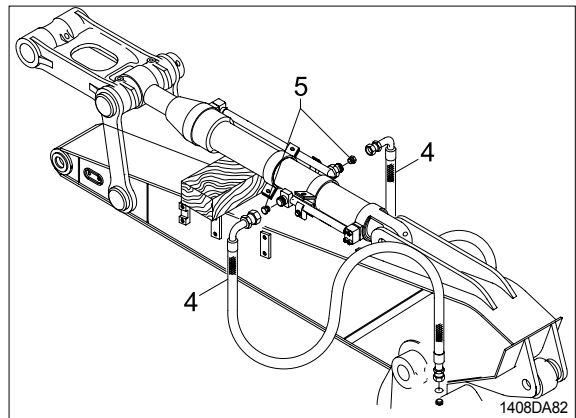
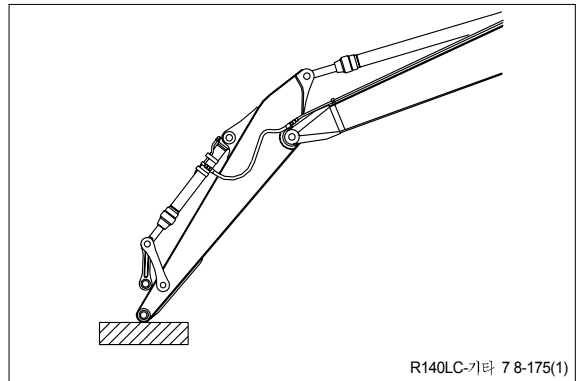

(2) Install

- ① Carry out installation in the reverse order to removal.

▲ When lifting the arm assembly, always lift the center of gravity.

- ※ Bleed the air from the cylinder.

3) BOOM ASSEMBLY

(1) Removal

- ① Remove arm and bucket assembly.
For details, see **removal of arm and bucket assembly**.
- ② Remove boom cylinder assembly from boom.
For details, see **removal of arm cylinder assembly**.

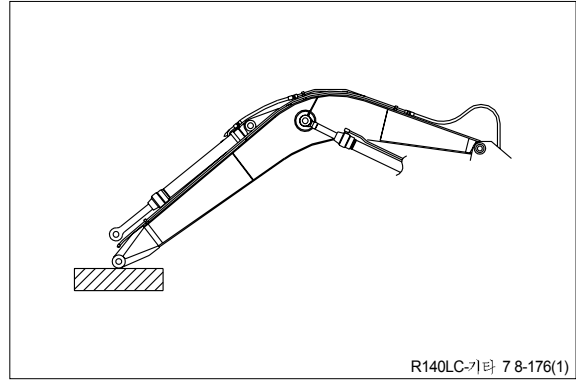

- ③ Disconnect head lamp wiring.
- ④ Disconnect bucket cylinder hose(2) and arm cylinder hose(1).
※ When the hose are disconnected, oil may spurt out.
- ⑤ Sling boom assembly(3).

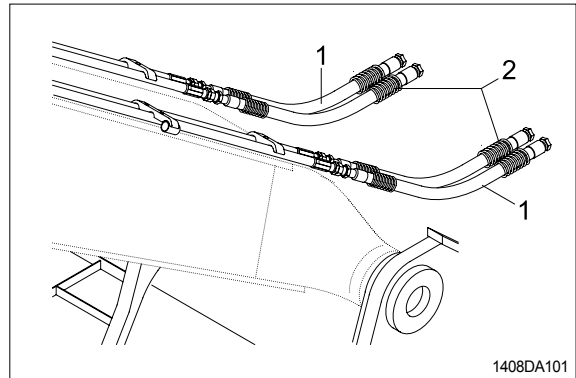

- ⑥ Remove bolt(4), plate(5) and pull out the pin(6) then remove boom assembly.
· Weight :880kg(1940lb)
※ When lifting the boom assembly always lift the center of gravity.

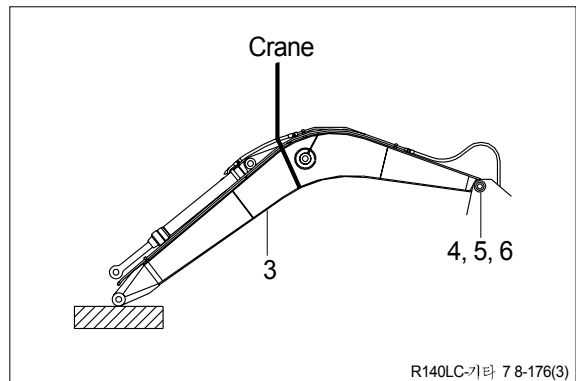

(2) Install

- ① Carry out installation in the reverse order to removal.
- ▲ **When lifting the arm assembly, always lift the center of gravity.**
- ※ Bleed the air from the cylinder.

