

## GROUP 6 TRAVEL DEVICE

### 1. REMOVAL AND INSTALL

#### 1) REMOVAL

- (1) Swing the work equipment 90° and lower it completely to the ground.
- (2) Operate the control levers and pedals several times to release the remaining pressure in the hydraulic piping.
- (3) Loosen the breather slowly to release the pressure inside the hydraulic tank.

**▲ Escaping fluid under pressure can penetrate the skin causing serious injury.**

※ When pipes and hoses are disconnected, the oil inside the piping will flow out, so catch it in oil pan.

- (4) Remove the track shoe assembly.  
For details, see **removal of track shoe assembly**.
- (5) Remove the cover.
- (6) Remove the hose.  
※ Fit blind plugs to the disconnected hoses.
- (7) Remove the bolts and the sprocket.
- (8) Sling travel device assembly(1).
- (9) Remove the mounting bolts(2), then remove the travel device assembly.  
· Weight : 165kg(240lb)

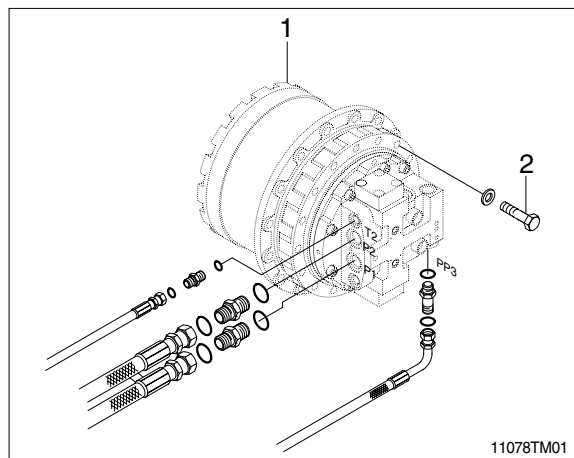

#### 2) INSTALL

- (1) Carry out installation in the reverse order to removal.
- (2) Bleed the air from the travel motor.
  - ① Remove the air vent plug.
  - ② Pour in hydraulic oil until it overflows from the port.
  - ③ Tighten plug lightly.
  - ④ Start the engine, run at low idling, and check oil come out from plug.
  - ⑤ Tighten plug fully.
- (3) Confirm the hydraulic oil level and check the hydraulic oil leak or not.

## 2. TRAVEL MOTOR

### 2) STRUCTURE

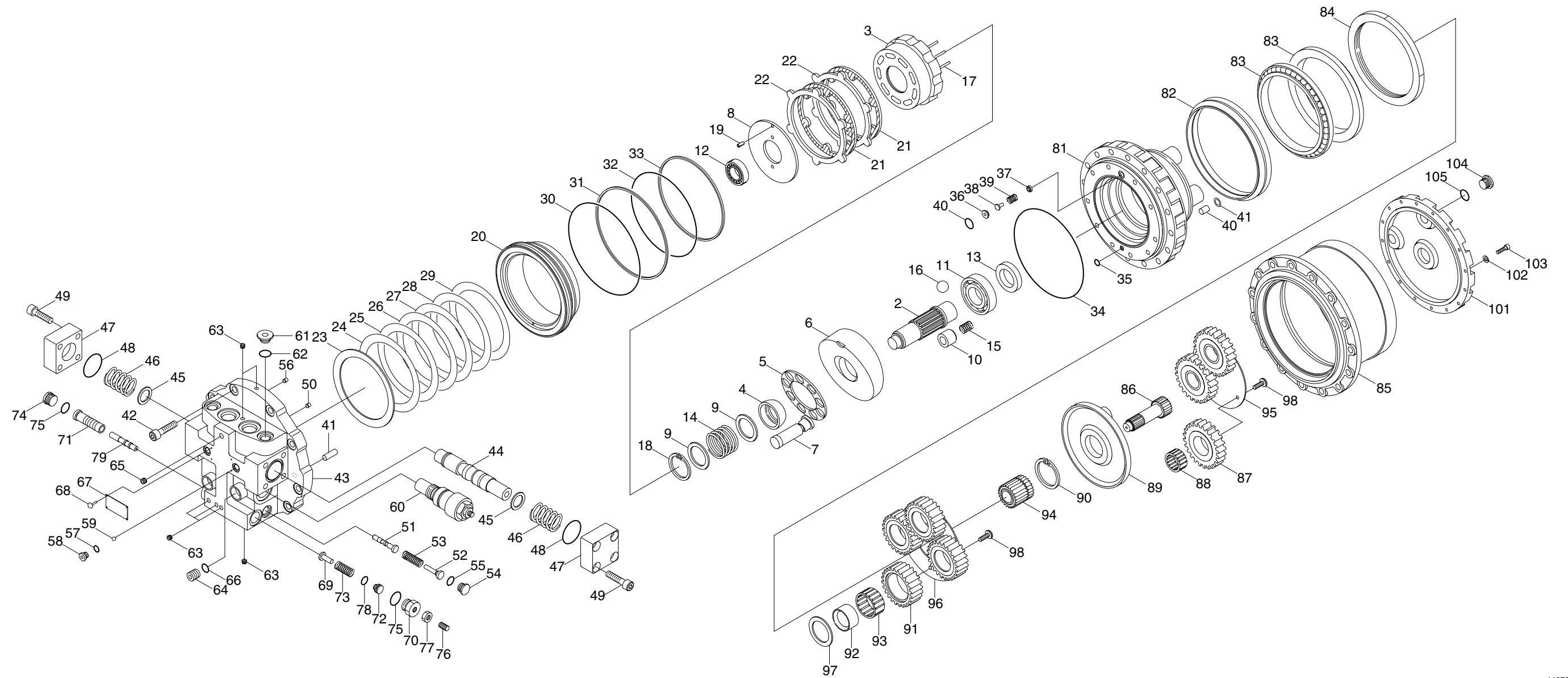

2 Shaft	20 Brake piston	37 Retainer	54 Plug	71 Sleeve	89 Carrier
3 Cylinder barrel	21 Friction plate	38 Poppet	55 O-ring	72 Stopper	90 Sun gear B
4 Ball retainer	22 Steel plate	39 Spring	56 Orifice	73 Spring	91 Planetary gear B
5 Retainer	23 Disk spring	40 O-ring	57 Steel ball	74 Plug	92 Bushing
6 Cam	24 Shim(1.0T)	41 Pin	58 Plug	75 O-ring	93 Needle bearing B
7 Piston assembly	25 Shim(1.2T)	42 Bolt	59 O-ring	76 Screw	94 Snap ring
8 Valve plate	26 Shim(1.4T)	43 Motor cover assembly	60 Relief valve assembly	77 Nut	95 Thrust plate(2)
9 Plate	27 Shim(1.6T)	44 Spool assembly	61 Plug	78 O-ring	96 Thrust plate(3)
10 Piston assembly	28 Shim(1.8T)	45 Washer	62 O-ring	79 Rod	97 Thrust plate(4)
11 Ball bearing	29 Shim(2.0T)	46 Spring	63 Plug	81 Casing body	98 Screw
12 Roller bearing	30 O-ring	47 Cover	64 Plug	82 Floating seal	99 Washer
13 Oil seal	31 Back up ring	48 O-ring	65 Plug	83 Angular bearing	100 Parallel pin
14 Spring	32 O-ring	49 Bolt	66 O-ring	84 Ring nut	101 Cover
15 Spring	33 Back up ring	50 Orifice	67 Name plate	85 Casing gear	102 Spring washer
16 Steel ball	34 O-ring	51 Spool	68 Rivet	86 Sun gear A	103 Bolt
17 Pin	35 O-ring	52 Stopper	69 Spring guide	87 Planetary gear A	104 Plug
18 Snap ring	36 Seat	53 Spring	70 Plug	88 Needle bearing A	105 O-ring

11072TM04

## 2) TOOLS AND TIGHTENING TORQUE

### (1) Tools

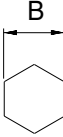
Tool name		Remark	
Allen wrench		5, 6, 8, 10, 14	
Socket for socket wrench, spanner	Socket	22, 30, 32, 41	
	Rod	5, 6, 8, 10, 14, 19	
Torque wrench		Capable of tightening with the specified torques	
Pliers		-	
(-) Driver		150mm	
Plastic and iron hammer		Wooden hammer allowed. Normal 1 or so	
Steel rod approx		7×7×200mm	
Monkey wrench		-	
Oil seal inserting jig		-	
Bearing pliers		-	
Seal tape		-	
Eye bolt		PF1/2, M16	
Press(0.5 ton)		-	
Oil stone		-	
Bearing assembling jig		-	
Liquid packing		Loctite #577	
Screw lock		Loctite #243	

### (2) Tightening torque

Part name	Item	Size	Torque	
			kgf · m	lbf · ft
Screw	98	M10	7.0±0.5	50.6±3.6
Bolt	103	M8	3.6±0.2	26.0±1.4
Plug	104	PF3/4	10.0±1.0	72.3±7.2
Bolt	42	M14	19.5±1.5	141.0±10.8
Orifice	43	NPTF1/16	1.0±0.1	7.2±0.7
Plug	44	M20	8.6±0.8	62.2±5.8
Bolt	49	M12	8.0±0.8	57.9±5.8
Orifice	50	NPTF1/16	1.0±0.1	7.2±0.7
Plug	54	PF3/8	5.0±0.5	36.2±3.6
Orifice	56	NPTF1/16	1.0±0.1	7.2±0.7
Plug	58	PF1/8	2.0±0.2	14.5±1.4
Relief valve body	60-1	M28	20.0±2.0	144.7±14.5
Cap nut	60-7	M38	20.0±2.0	144.7±14.5
Screw	60-10	M10	3.5±0.2	25.3±1.4
Plug	61	3/4-16UNF	7.0±0.5	50.6±3.6
Plug	63	NPTF1/16	1.0±0.1	7.2±0.7
Plug	64	9/16-18UNF	5.0±0.5	36.2±3.6
Plug	65	PT1/8	2.0±0.2	14.5±1.4
Plug	70	7/8-14UNF	8.0±0.8	57.9±5.8
Plug	74	7/8-14UNF	8.0±0.8	57.9±5.8
Screw	76	M10	3.5±0.2	25.3±1.4

### **3. DISASSEMBLY**

#### **1) GENERAL PRECAUTIONS**

- (1) Before disassembling the motor, check the items to be inspected and, for remedy against trouble, closely examine the nature of the trouble, so that the motor can be disassembled effectively.
- (2) To disassemble the motor, use the disassembling procedures described in section 2) and select a clean place.
- (3) Place a rubber or vinyl sheet or other such protective materials on your working bench to protect the surface of the motor to be serviced.
- (4) During disassembly, give a match mark to the mating surfaces of each part.
- (5) Arrange removed parts in order so that they will not become damaged or missing during disassembly.
- (6) Once seals have been disassembled, they should be replaced even if damage is not observed. Have replacement seals ready on hand before starting your disassembling job.

## 2) DISASSEMBLING PROCEDURE

- (1) Clean the outside of the travel motor completely before disassembling.

Be aware that in re-assembling, the parts must be installed in the original locations.

For this purpose, it is strongly recommended to record the original positions of the parts before and during disassembling process.

- (2) Remove the drain plug and drain the lubricating oil. The capacity of the travel motor is 2.5 liters (0.55U.K.gal; 0.66U.S.gal). Place the travel motor on the flat clean ground.

- (3) Remove one relief valve(1) shown in the picture.

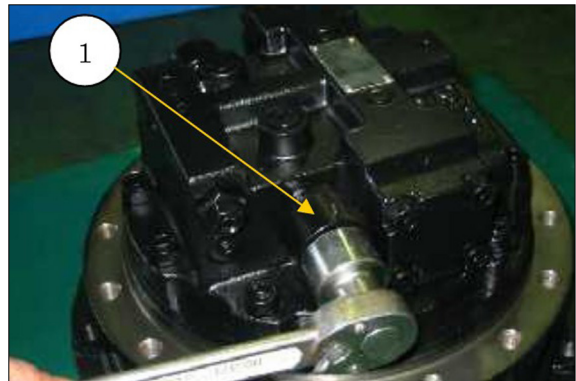
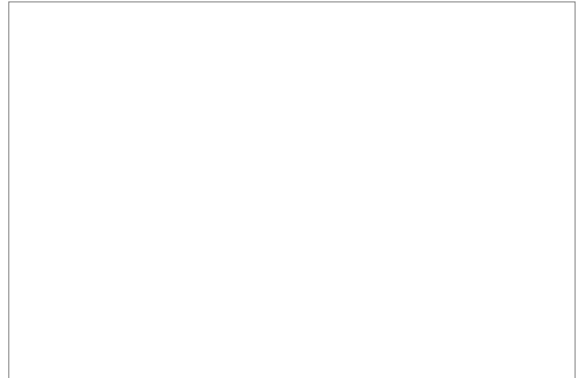

11078TM12

- (4) Remove ten bolts(2) and motor cover(3).  
※ Removing the relief valve(1) first makes it easier to remove ten bolts(2) and brake valve(3) later as shown.

**▲ Be careful not to drop a valve plate. Don't give damage to it. It is on the motor cover inside surface.**

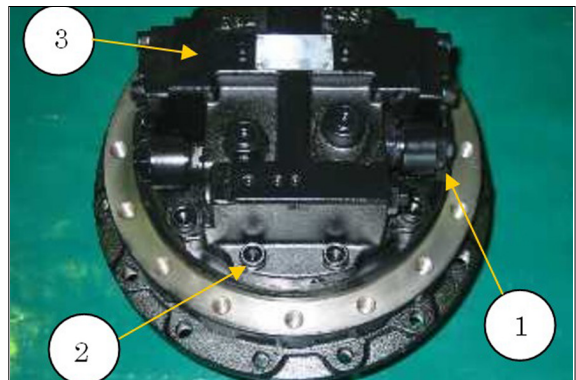

11078TM11

- ※ It would be easier to remove motor cover if you temporarily replace two bolts with two "tool" bolts(4) of yours as shown.  
(You don't have to use them necessarily).
- Bolt thread size = M12 × P1.75
  - Bolt length = about 70mm(for example)



11078TM13

- (5) Place brake valve(3) on wood blocks(5) as shown.

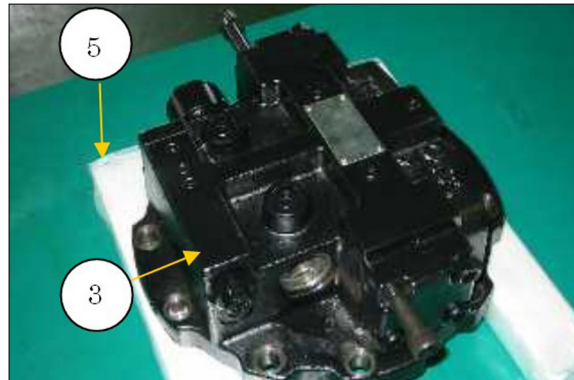

11078TM14

- (6) Remove back-up ring(6) and O-ring(7) from the relief valve(1).



11078TM15

(7) Remove two diagonal bolts(8) on one side as shown. Then, loosen the two remaining bolts little by little alternately until they are removed completely.

Remove cover(9) from the brake valve.

**▲ There is strong spring pressure under the cover(9). For your safety and preventing damage, be sure to loosen the bolts carefully so that spring pressure is under your control. Follow the procedure below.**

※ If it is difficult to pull out the spool assembly(12) because of vacuum action, it will be easier by loosening another 4 bolts(8) and cover(9) on the other side a little. (Face distance 0.5mm is enough)

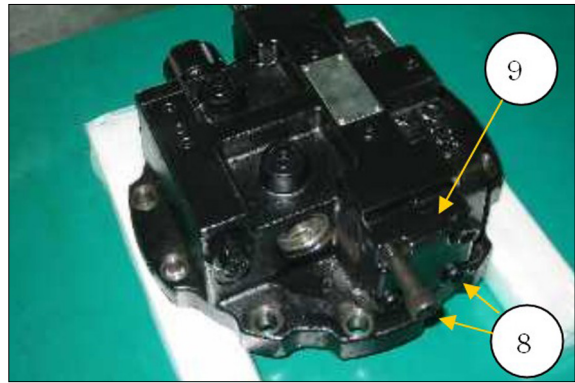

11078TM16

(8) Remove spring(10), washer(11) and spool assembly(12) from the brake valve. They are located behind the cover(9).

※ Don't disassemble spool assembly(12). The component(12) should be serviced only as an assembly.

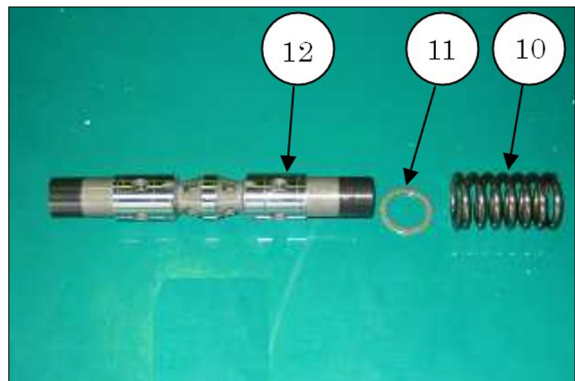

11078TM17

(9) Remove O-ring(13) and plug(14) from the brake valve.

Remove the O-ring from plug(14).

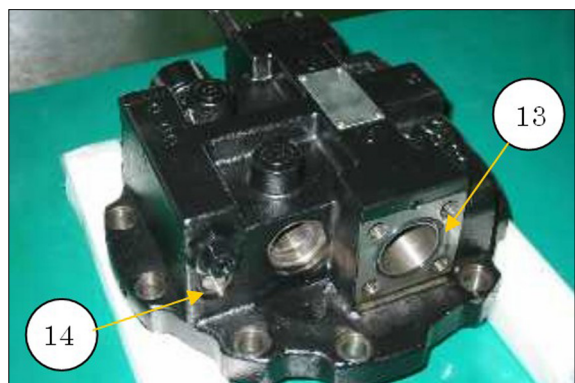

11078TM18

(10) Remove stopper(15), spring(16), and spool(17) located behind plug(14), from the brake valve.

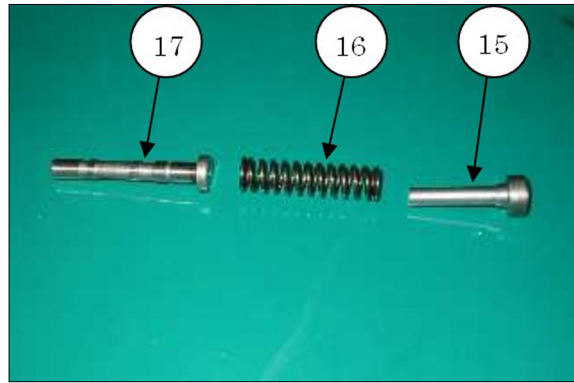

11078TM19

(11) Remove two plugs(18).

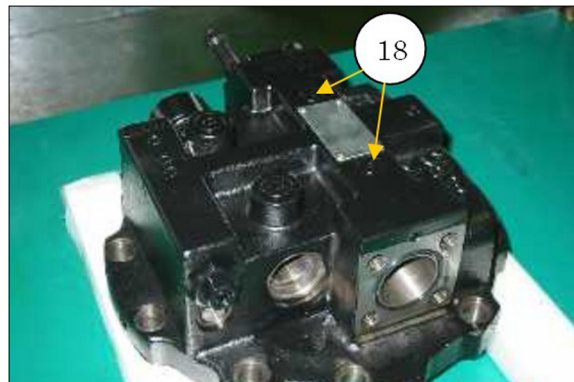

11078TM20

(12) Remove O-ring(19) from each plug. Remove steel balls(20) from the brake valve.

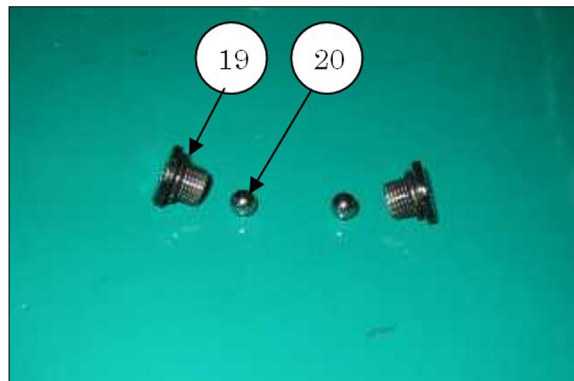

11078TM21

(13) Remove one relief valve(21) shown in the picture.

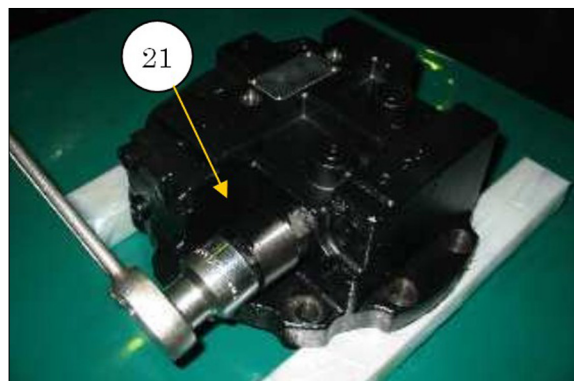

11078TM22



(14) Remove back-up ring(22) and O-ring(23) from the relief valve.



11078TM23

(15) Remove plug assembly(24) from the brake valve.

- ※ Don't disassemble plug assembly(24). The screw setting must be kept at the original condition.

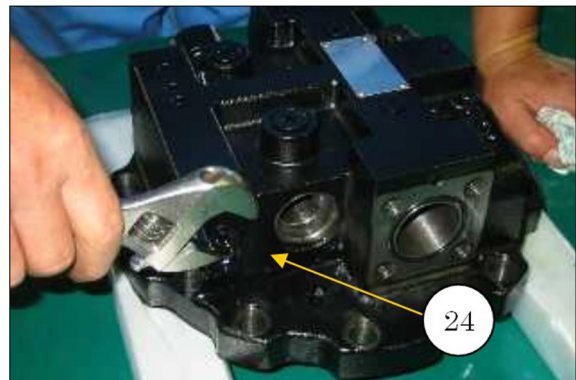

11078TM24

(16) Remove plug(25).

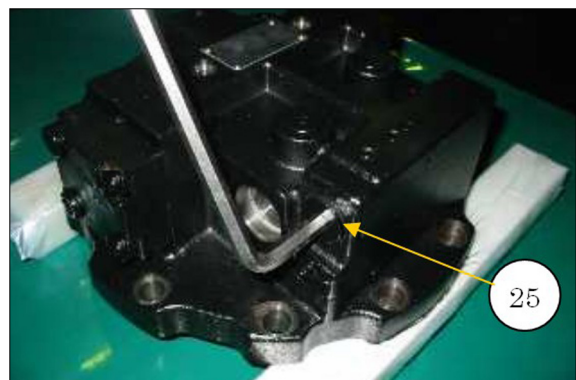

11078TM25

(17) Remove spring(26), spring guide(27) and rod(28) behind plug assembly(24). Remove the O-ring(29) from plug assembly(24). Remove the O-ring(30) from plug(25).

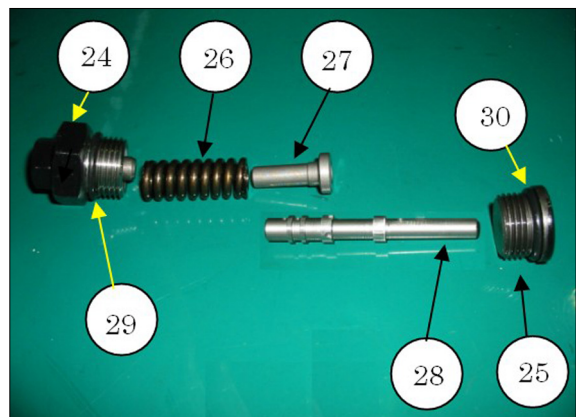

11078TM26

- ※ You don't have to remove sleeve inside the brake valve if the speed-shifting is functioning in order.

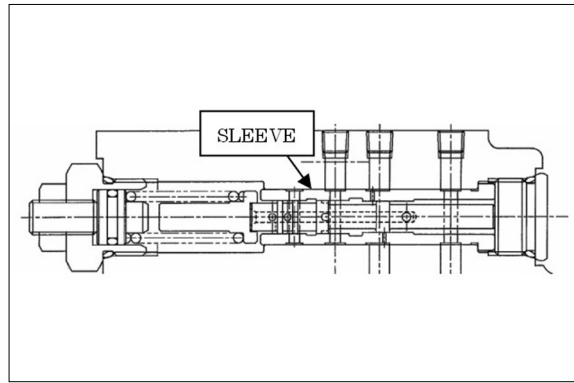

11078TM27

- (18) Remove four bolts(31) and remove cover (32). Refer to step 7.

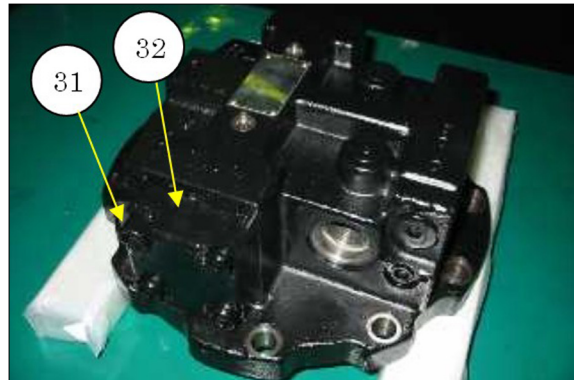

11078TM28

- (19) Place the brake valve upside-down as shown. Remove valve plate(33) from the brake valve.

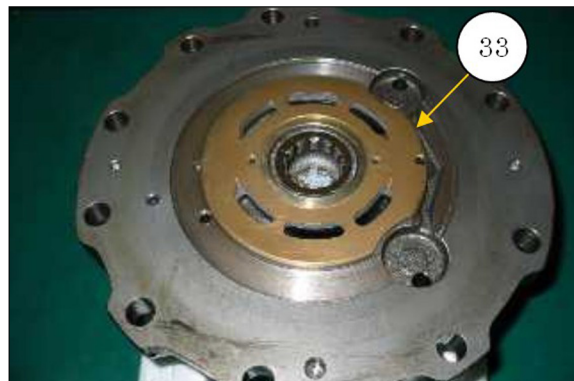

11078TM29

- (20) If necessary, remove bearing(34) and location pin(35).

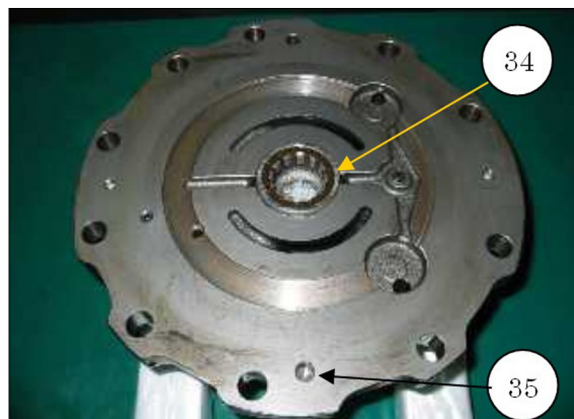

11078TM30

(21) Remove three O-rings(36)(37)(38), two disk springs(39), and shim(40) from the body casing.

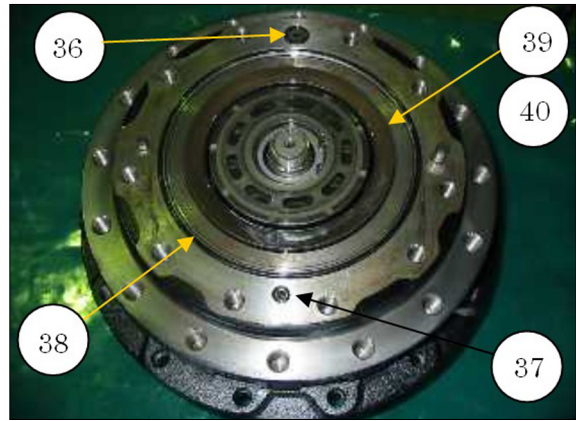

11078TM31

(22) Install tooling "Brake piston puller" as shown.

- a. Screw-in two bolts to the brake piston.
- b. Turn the center bolt little by little and let the center bolt push the shaft. Then the brake piston comes out.
- c. Remove brake piston(41).

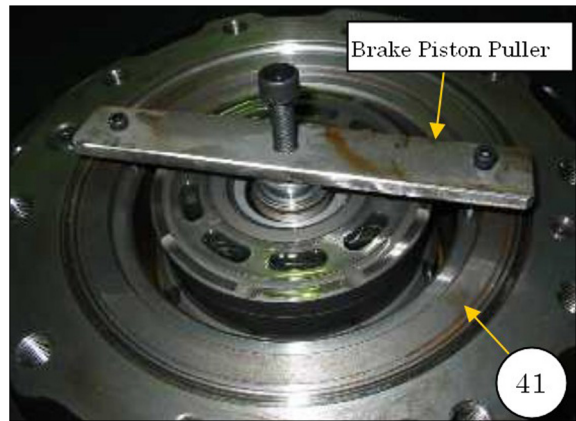

11078TM32

(23) Remove O-rings(42)(43) and back-up rings(44)(45) from the brake piston.

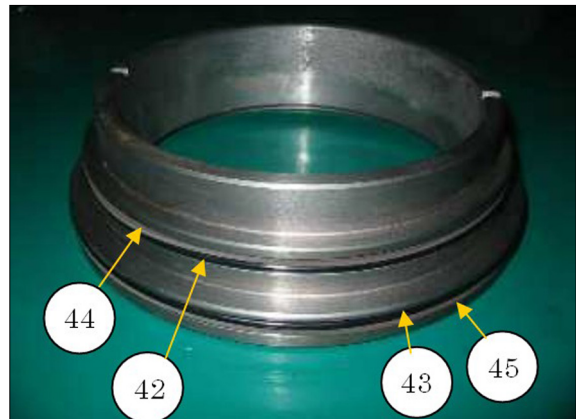

11078TM33

(24) Remove two friction plates(46) and two steel plates(47) from the body casing, using a steel wire, a magnet, etc. Don't pull off the cylinder barrel component yet.



11078TM34



11078TM35

(25) Position the travel motor as shown on a wood block and apply wood wedges that prevent the travel drive from rolling around. Remove cylinder barrel assembly (48) from the body casing.

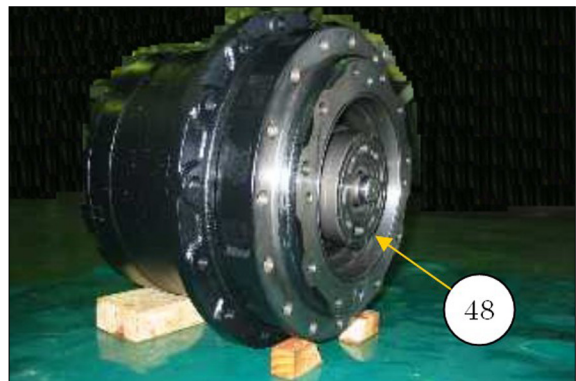

11078TM36



11078TM37

(26) Be aware that in re-assembling, retainer(49), piston assemblies(50) and cylinder barrel(51) must be installed in the original locations.

For this purpose, it is strongly recommended to record the original positions of the parts before and during disassembling process.

(27) Remove retainer(49) and piston assemblies(50) from barrel(51). Separate the piston assemblies from the retainer.

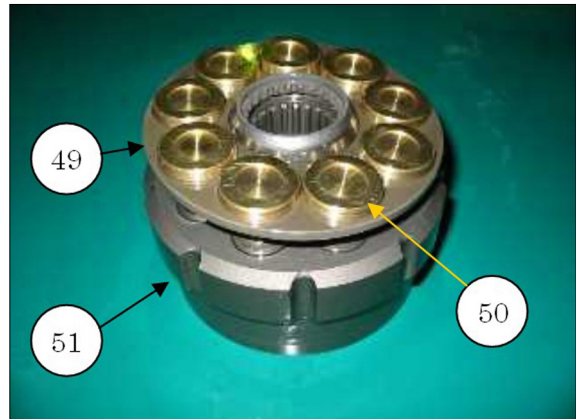

(28) Remove retainer ball(52) from the cylinder barrel.



(29) Remove three pins(53) from the cylinder barrel.



(30) Give a slight amount of compression on plate(54) with a press machine using a suitable size diameter jig.

Remove snap ring(55). Remove plate(54) spring(56) and plate(57) from the cylinder barrel(51).

**▲ There is strong spring force behind plate (54). For your safety and avoiding damage, a press machine should be used to hold spring compression in disassembling the internal components in cylinder barrel.**



11078TM41

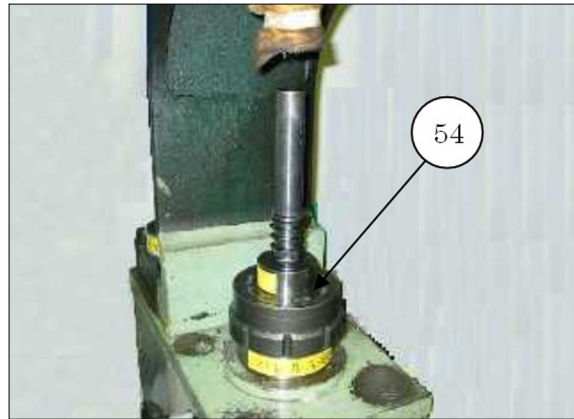

11078TM42

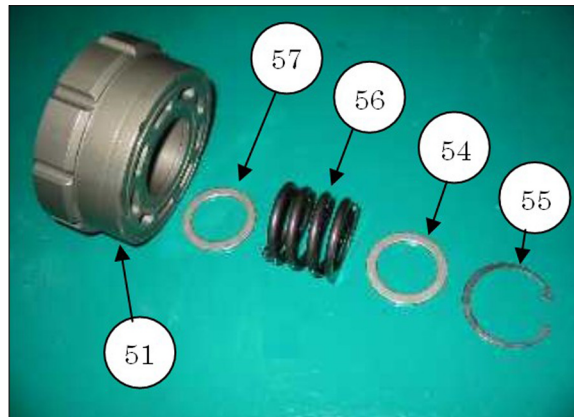

11078TM43

(31) Remove cam(58) from the body casing.

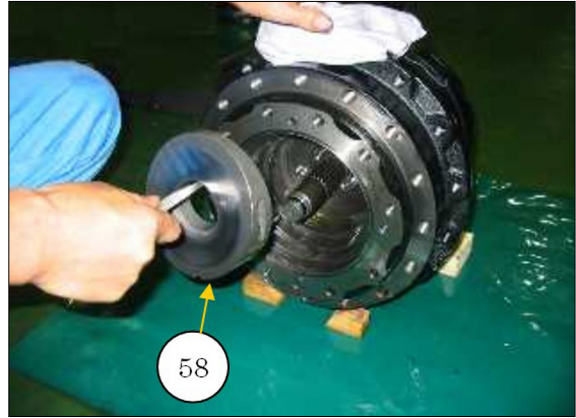

11078TM44

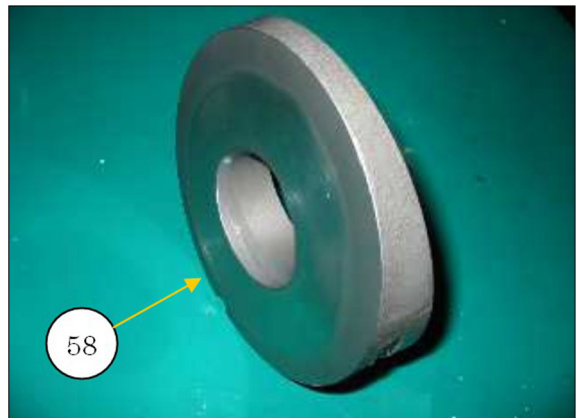

11078TM45

(32) Remove two steel balls(59) and piston(60) from the body casing. Remove the spring(61) behind the piston.

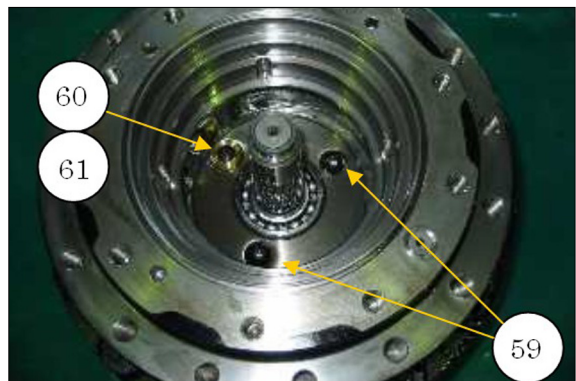

11078TM46



11078TM47

(33) Place the travel motor on wood blocks as shown. Remove sixteen bolts(62) and washers(63).

⚠ To avoid damaging shaft, don't put the travel motor directly on a flat ground but use blocks.

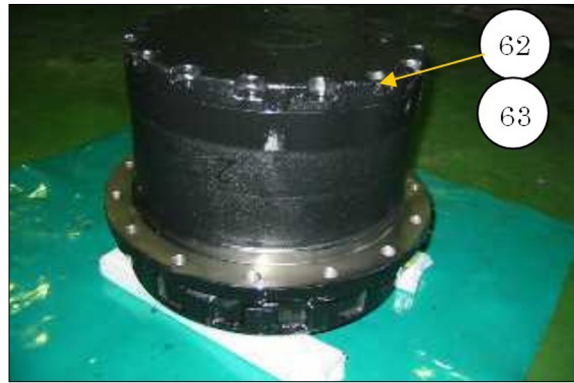

11078TM48

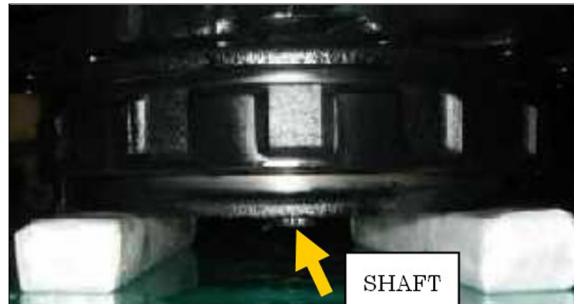

11078TM49

(34) With a soft-faced hammer, break the seal between cover(64) and gear casing(65). Remove the cover(64).

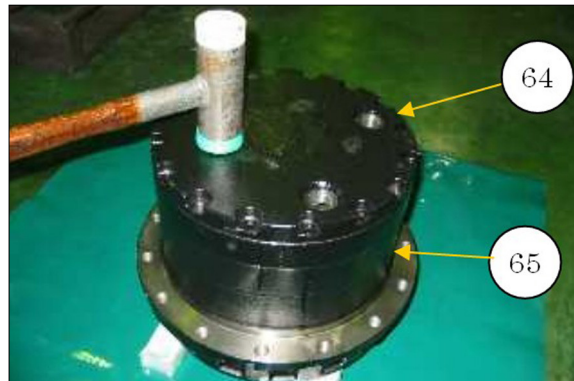

11078TM50



11078TM51



(35) Remove three bolts(66) and a thrust plate(67).

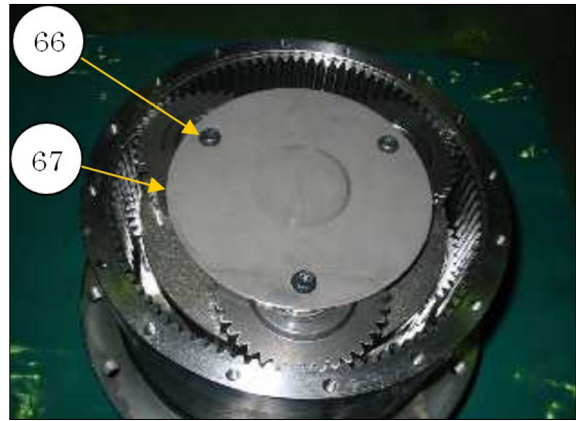

11078TM52

(36) Remove sun gear(68), three planetary gears(69) and three bearings(70).

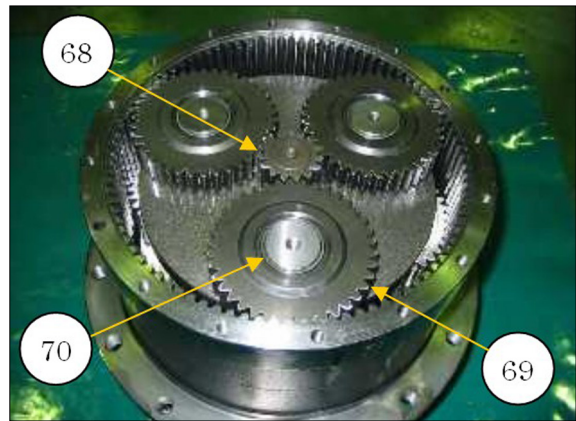

11078TM53

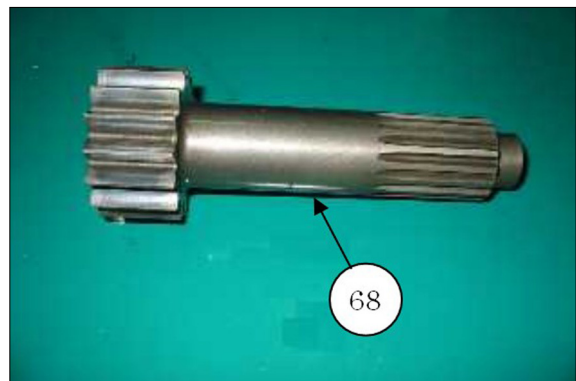

11078TM54

(37) Remove carrier(71).



11078TM55

(38) If necessary, remove three inner races(72) from the carrier shaft.

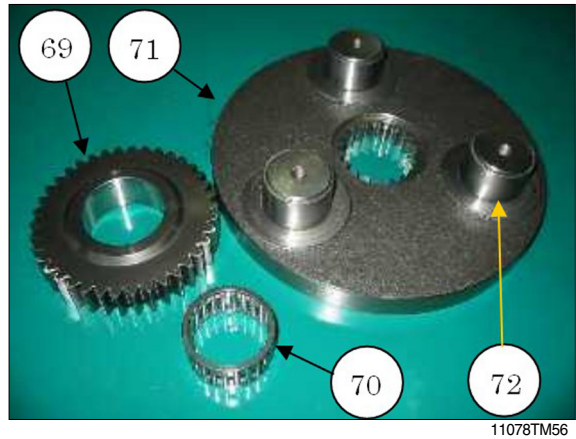

(39) Remove sun gear(73).

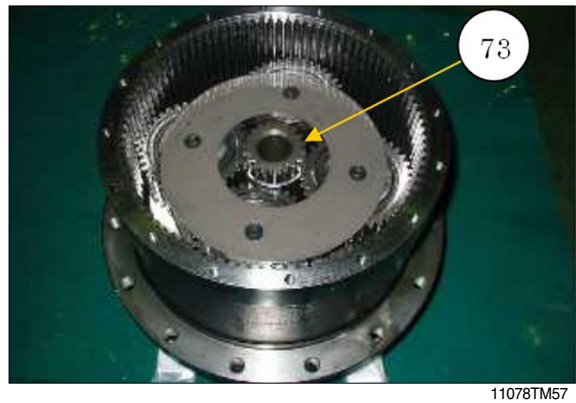

(40) Remove snap ring(74) from sun gear(73).

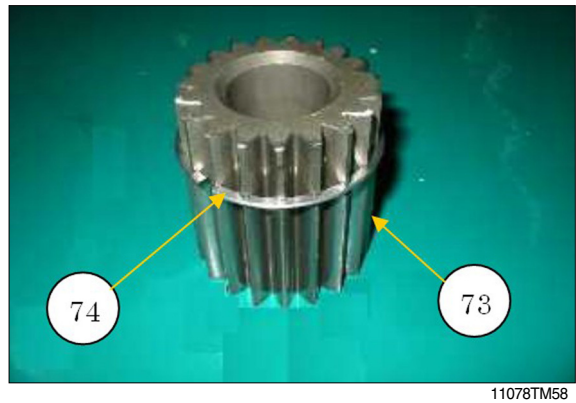

(41) Remove four bolts(75) and a thrust plate (76).

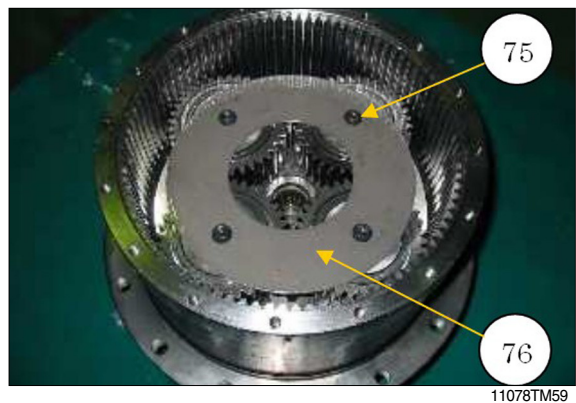

(42) Remove four planetary gears(77), four bearings(78), four bushes(79) and four plates(80).

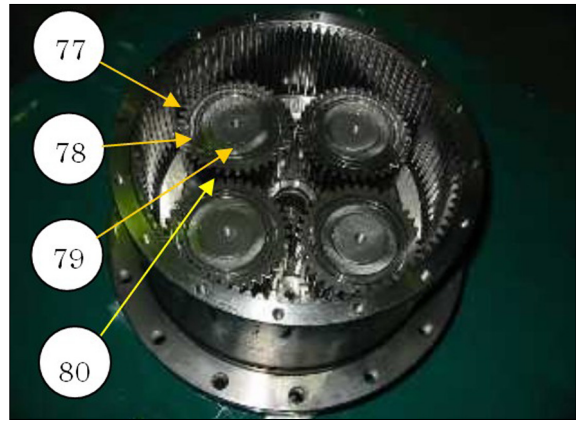

11078TM60

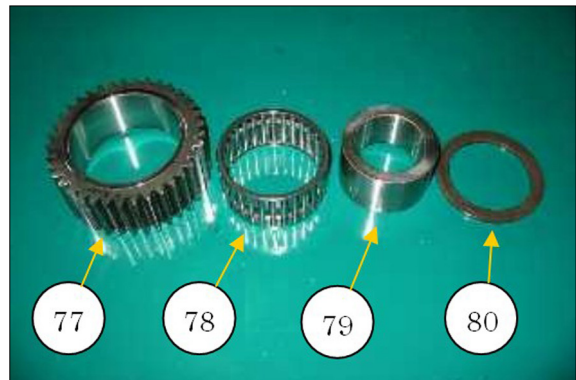

11078TM61

(43) Remove bolt(81) and washer(82).

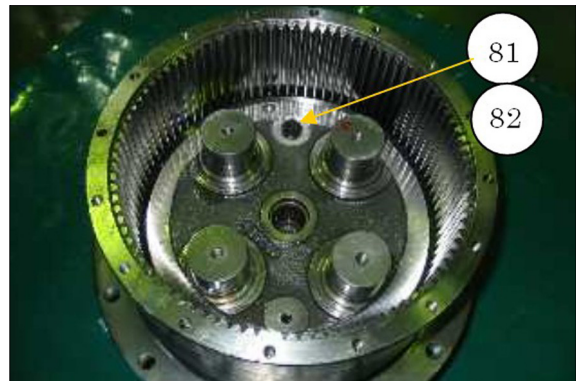

11078TM62

(44) Remove pin(83) with a magnet.  
If it is difficult, follow the procedure below.  
① Put a cover plate over the tap hole as shown.  
② Drill a hole to the pin(83).  
③ Drill a tap to the hole in the pin(83).  
④ Screw-in a bolt to some degree and pull off the pin with the bolt.

(45) Remove ring nut(84) from the body casing.

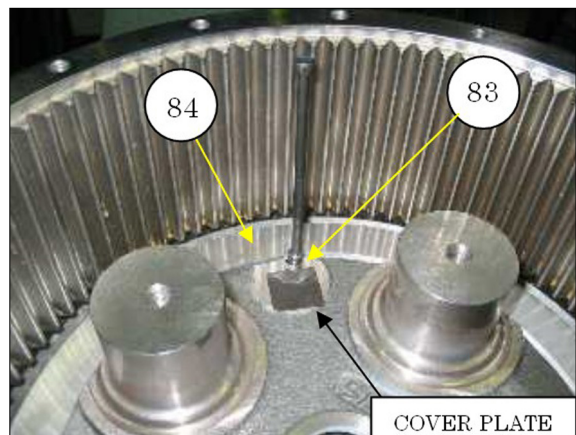

11078TM63

(46) Remove the gear casing(65) from the body casing with a hoist.

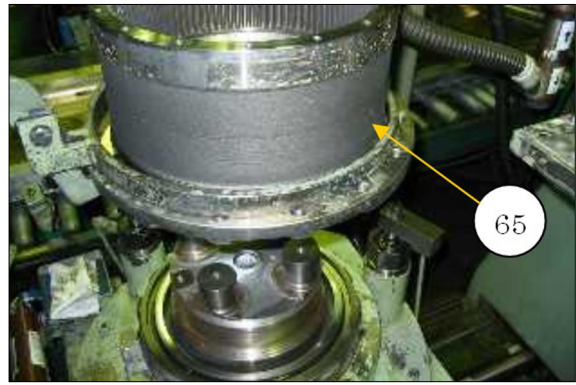

(47) Remove an angular bearing(85) from the gear casing.



(48) Put the gear casing upside-down. Remove a floating seal(86) and another angular bearing(87) from the gear casing.

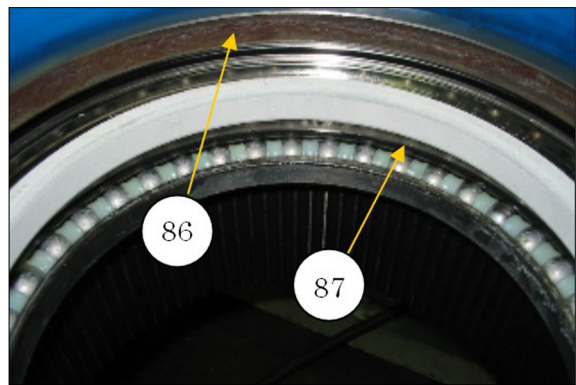

(49) Remove another floating seal(88) from body casing(89). Remove shaft(90) and bearing(91) from the body casing by giving force as shown with an arrow in the picture using a soft-faced hammer and a proper jig. Sometimes, bearing(91) may remain in the body casing. In this case, remove the bearing(91) as shown in the step 50.

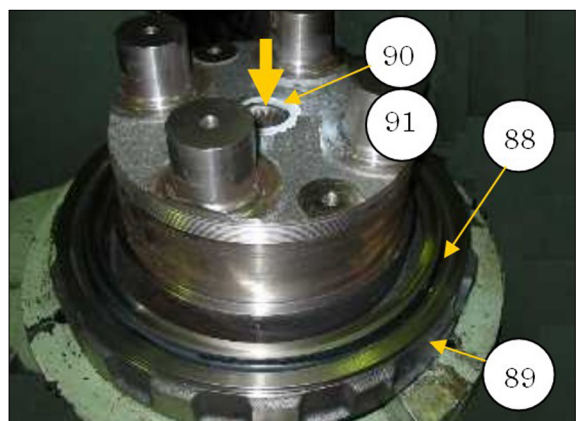

(50) If necessary, remove a bearing(91) from the body casing.  
Remove an oil seal(92) from the body casing.



11078TM68

(51) If necessary, remove a bearing(91) from the shaft(90). If necessary, remove an inner race(93) from the shaft(90).

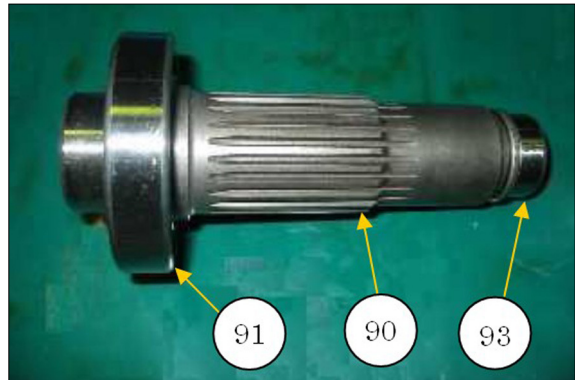

11078TM69

This is the end of disassembling process.

## 4. ASSEMBLY

### 1) GENERAL PRECAUTIONS

- (1) Reassemble in a work area that is clean and free from dust and grit.
- (2) Handle parts with bare hands to keep them free of lint contaminants.
- (3) Repair or replace the damaged parts.  
Each parts must be free of burrs its corners.
- (4) Do not reuse O-rings, oil seal and floating seal that were removed in disassembly.  
Provide the new parts.
- (5) Wash all parts thoroughly in a suitable solvent.  
Dry thoroughly with compressed air.  
Do not use the cloths.
- (6) When reassembling oil motor components of motor, be sure to coat the sliding parts of the motor and valve with fresh hydraulic oil. (NAS class 9 or above)
- (7) Use a torque wrench to tighten bolts and plugs, to the torque specified as follows.

## 2) ASSEMBLING PROCEDURE

- (1) Make sure that all the parts are completely clean and free of dirt and debris before assembling.

Check the condition of all O-rings, back-up rings, and oil seal used in the travel motor. If any of them have any damage, replace them with new ones.

Put the body casing on a clean sheet spread on the flat base.

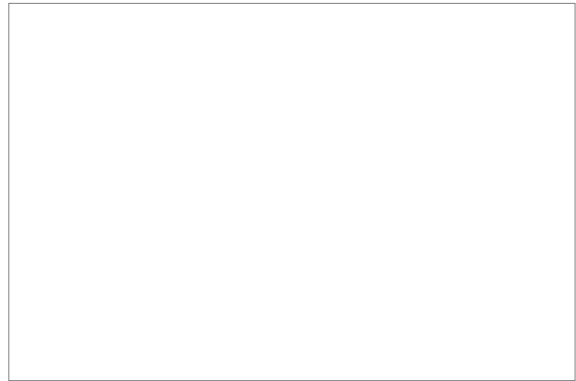

- (2) Install oil seal to body casing.  
Put bearing(91) and inner race(93) on shaft(90).  
Install shaft(90) into the body casing.

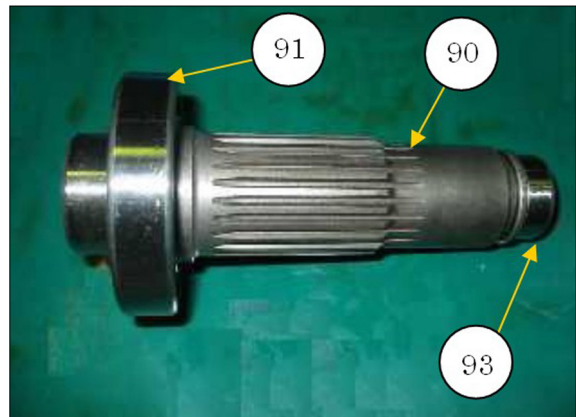

11078TM70

- ※ Before installing floating seals, make the O-ring(=rubber) and seal ring(=metal) clean and dry.  
After installing the seals, put clean SAE30 engine oil or gear oil 80W-90 on the contact surfaces of the metal seals.

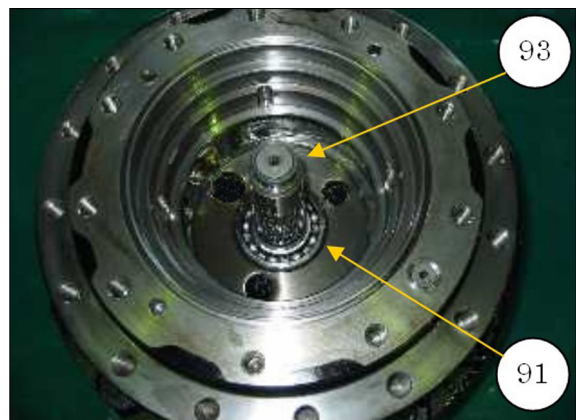

11078TM71

- (3) Place the body casing on wood blocks or other proper jigs with the shaft side down.

- ▲ To avoid damaging shaft, don't put the body casing directly on a flat ground.



11078TM72

- (4) Install floating seal(88) in the body casing, using tool "Floating seal installer".  
Then, put clean SAE30 engine oil or gear oil 80W-90 on the contact surface(flat surface) of the metal seal.



11078TM73

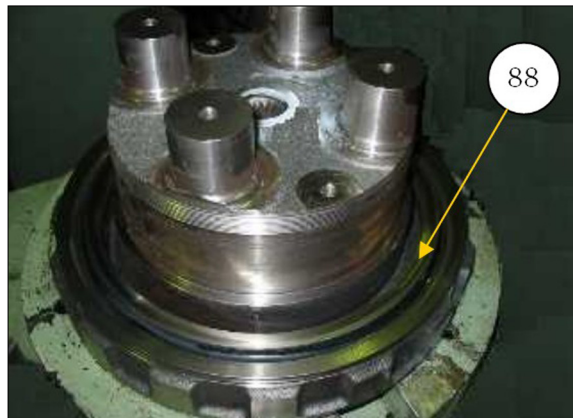

11078TM74

- (5) Install an angular bearing(85) to the gear casing.

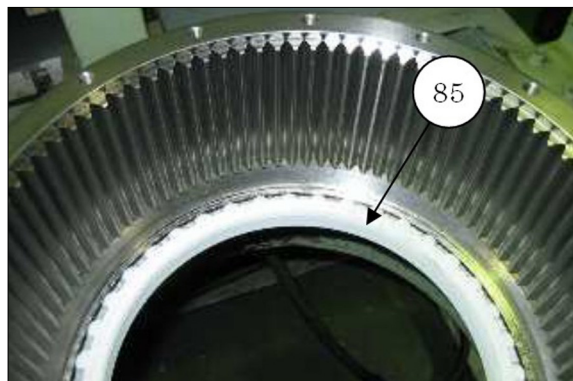

11078TM75

- (6) Put the gear casing upside-down as shown. Install another angular bearing(87) to the gear casing.  
※ Before installing floating seals, make the O-ring(=rubber) and seal ring(=metal) clean and dry.  
After the installation of the seals, put clean SAE30 engine oil or gear oil 80W-90 on the contact surfaces of the metal seals.

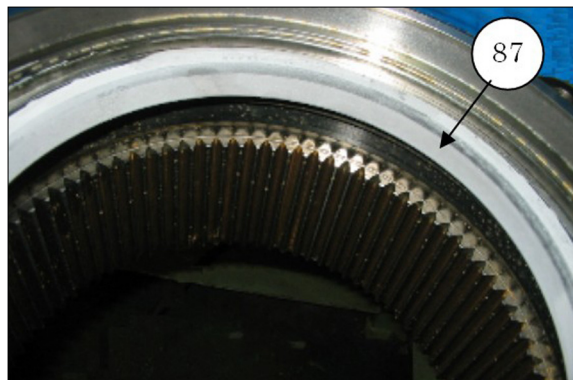

11078TM76



(7) Install another floating seal(86) in the gear casing, using tooling "Floating seal installer".

Then, put clean SAE30 engine oil or gear oil 80W-90 on the contact surface(flat surface) of the metal seal.

※ Be careful and don't scratch or damage the floating seals before and during assembling the two components.

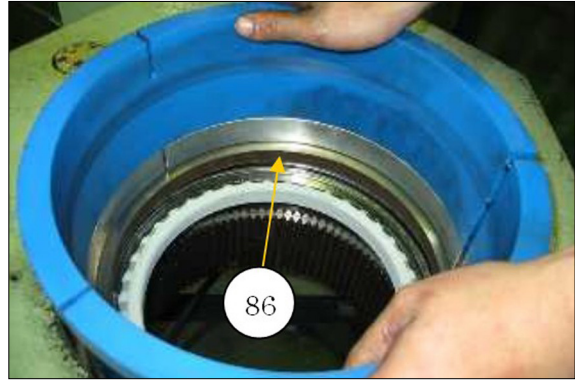

11078TM77

(8) Hoist a gear casing(65) over the body casing(89) as shown. Install the gear casing on the body casing(89).

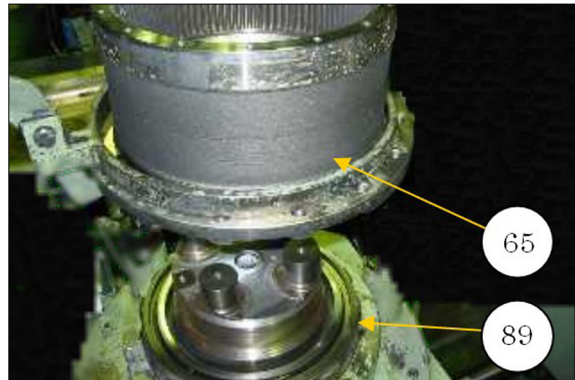

11078TM78

※ After installing the ring gear on the body casing, there will be a gap between two components. This is a normal phenomenon caused by the floating seals, and the gap will be eliminated by installing the ring nut(84).

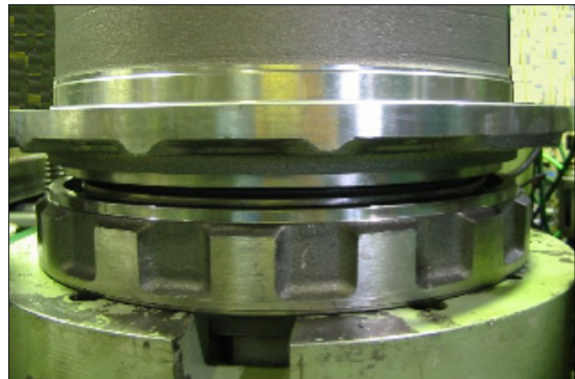

11078TM79

(9) Use the following procedure to make a preload adjustment of bearings(85) and (87) as follows :

- a. Tighten the ring nut(84) strongly enough until there is no gap among body casing, two bearings, gear casing, and ring nut.
- b. Rotate gear casing(65) several turns.
- c. Turn the ring nut(84) forward/backward and adjust the tightening position of the ring nut(84) until the pull-force of spring scale to the tangent-line direction while turning(as shown below) is **216~294N (48.5~66.1lbf)**.

※ To apply a pin to the ring nut, a new hole should be drilled at the opposite position from the original position. It is because that the rotating position of ring nut is not necessarily the same as the original position when it is adjusted by the procedure (9).

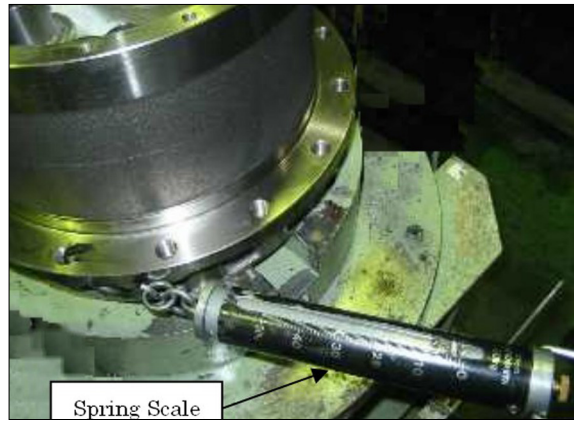

(10) Put a cover plate over the tap hole. Drill a new hole between body casing and ring nut as shown.

**Drill hole spec :**

- Drill hole diameter =  $\varnothing 8.00 \sim \varnothing 8.15\text{mm}$
- Drill hole depth =  $11.0 \sim 11.5\text{mm}$

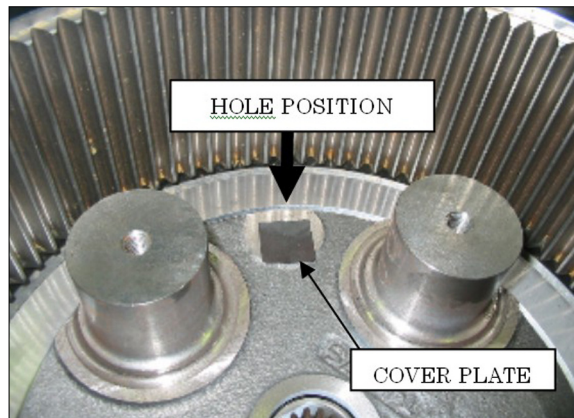

(11) Take away all the debris caused by drilling. Install pin(83) in a newly drilled hole between body casing(89) and ring nut(84).

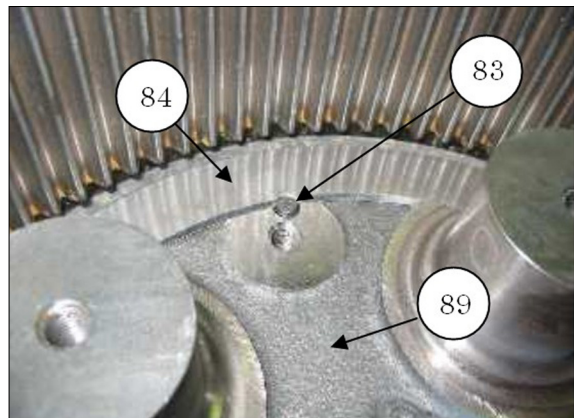

- (12) Apply Thread Lock "THREE BOND 2403" to bolt(81). Install bolt(81) and washer(82) to the body casing. Tighten the bolt to a torque of  $68.6 \pm 4.9$  N · m ( $50.6 \pm 3.6$  lbf · ft).

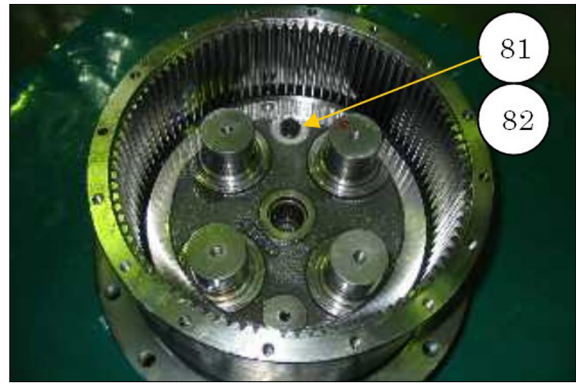

11078TM83

- (13) Position the travel motor as shown. Install two steel balls(59), spring(61) and piston assembly(60) in the body casing.

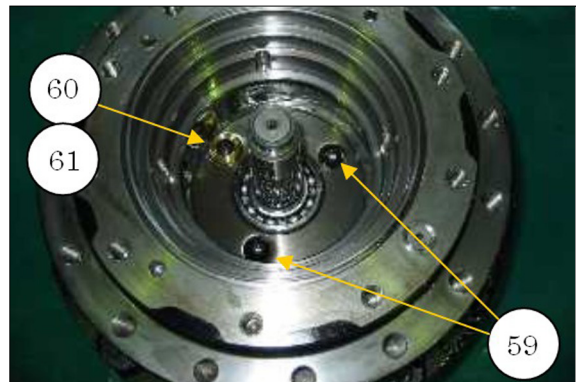

11078TM84

- (14) Install cam(58) in the travel motor body. By pushing the cam several times, confirm that the cam action is smooth.



11078TM85

- (15) Install plate(57), spring(56) and plate(54) in cylinder barrel(51).  
Use a press machine on plate(54), and compress spring(56).  
Install snap ring(55).

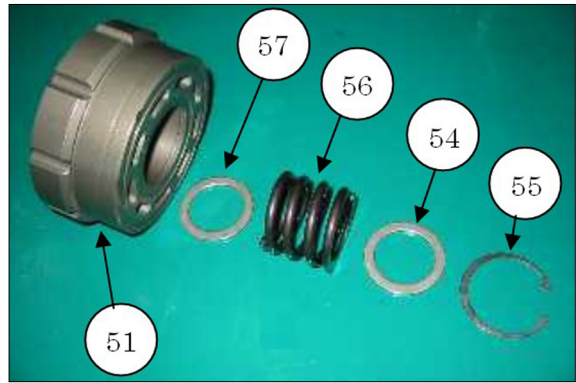

11078TM86

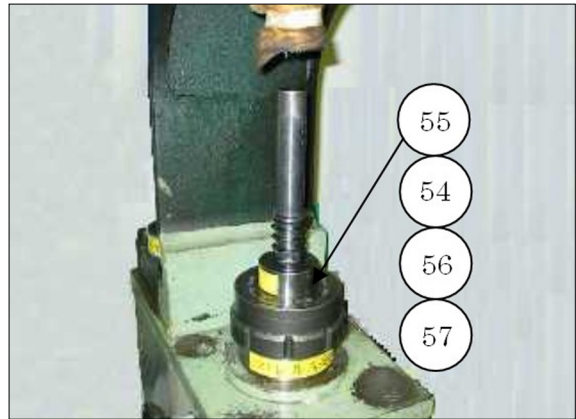

11078TM86

- (16) Install three pins(53) in the cylinder barrel.

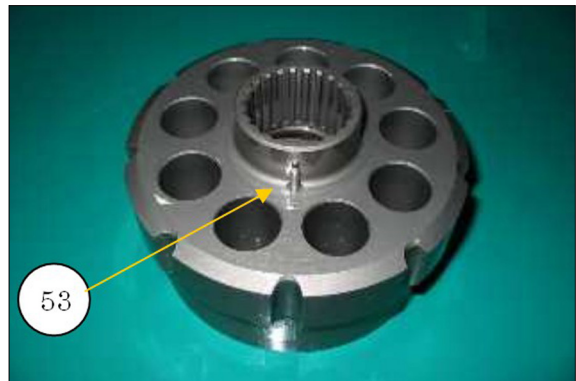

11078TM88

- (17) Install retainer ball(52) to the cylinder barrel. Put clean hydraulic oil on retainer ball(52).



11078TM89

(18) Install piston assemblies(50) in their original holes of retainer(49).

(19) Put clean hydraulic oil in the bores of the cylinder barrel and piston assemblies(50). Install the piston assemblies with the retainer in their original bores in cylinder barrel(51).

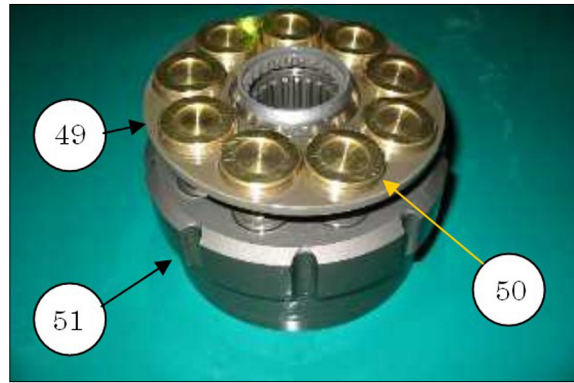

(20) Put clean hydraulic oil on the sliding surfaces of the cam, nine piston shoe surfaces sliding against cam, and on the splined shaft of the motor.

Then, put the travel motor body on its side and install cylinder barrel assembly(48) on the shaft as a unit.

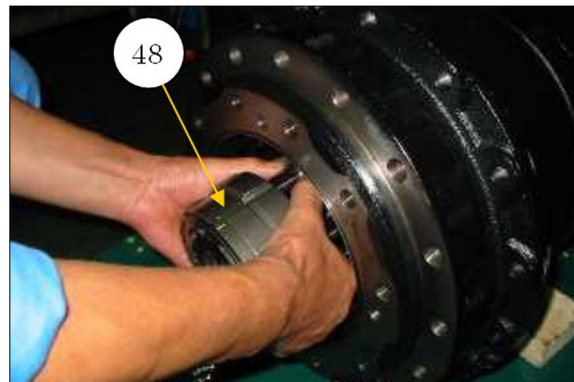

(21) Put clean hydraulic oil on two friction plates(46) and two steel plates(47). Install the plates in alternating order in the travel motor body. Start with a friction plate and end with a steel plate.

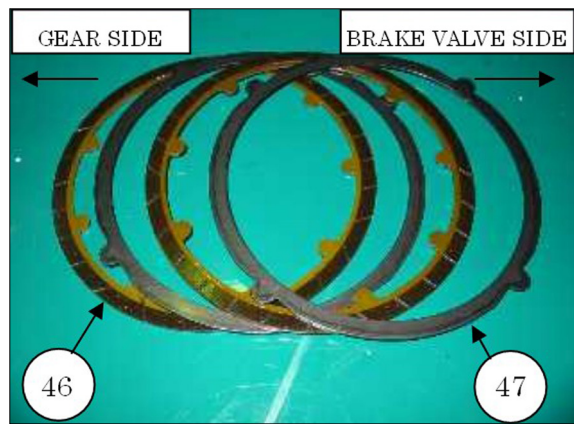

(22) Make sure brake piston(41) is completely clean and free of dirt and debris. Check the condition of back-up rings(44)(45) and O-rings(42)(43). If any of them have any damage, replace them with new ones. Install back up rings(44)(45) and O-rings(42)(43) on brake piston(41) as shown. Put some grease on the back-up rings and the O-rings. Be careful about the installing position of O-rings and back-up rings.

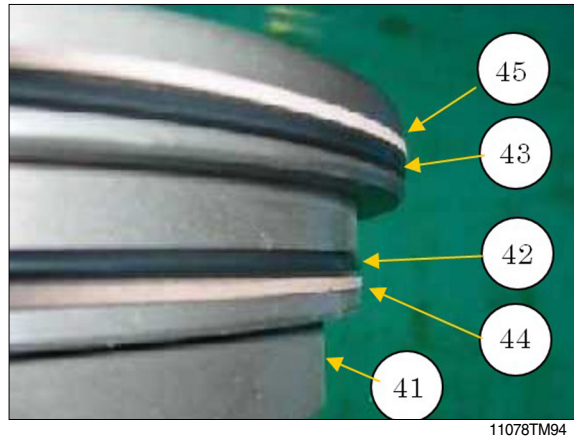

11078TM94

(23) Put clean hydraulic oil on the surface of the body casing, which makes contact with brake piston(41). Install brake piston(41) in the travel motor body using a soft-faced hammer.



11078TM95

(24) Install shim(40) in the brake piston. Next, install two disk springs(39) in the piston. The combination of the disk spring in installing is a shown. Install three O-rings(36)(37)(38) in the travel motor body.

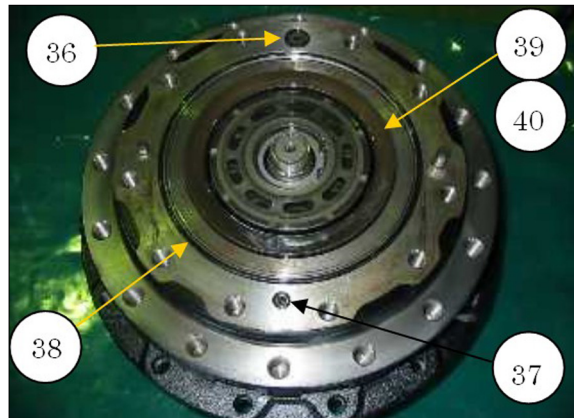

11078TM96

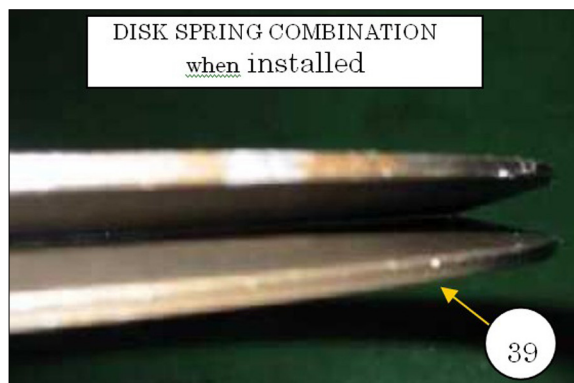

11078TM96

(25) Install bearing(34) and location pin(35) in the brake valve.

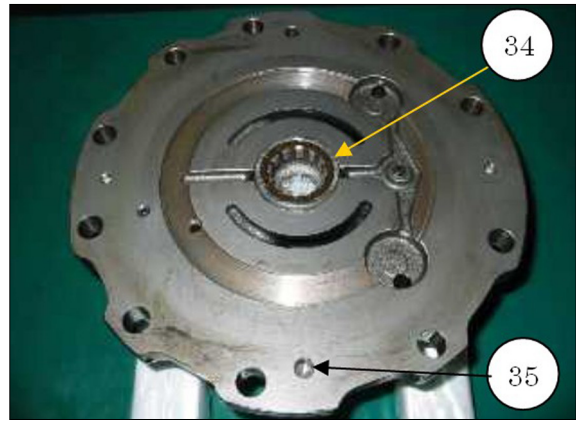

11078TM98

(26) Put the motor cover upside-down on wood blocks. Put some clean hydraulic oil on spool assembly(12), and install it in the valve body. Install washer(11) and then spring(10) in the valve body. Install O-ring(94) as shown.

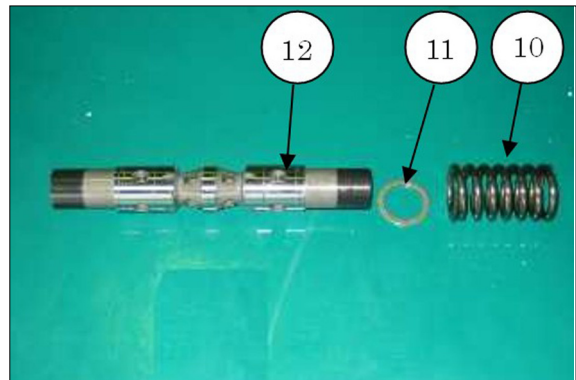

11078TM99



11078TM100

(27) Install cover(32) and four bolts(31). Tighten the bolts to a torque of  $78.5 \pm 7.8$  N · m ( $57.9 \pm 5.8$  lbf · ft). Be careful not to let the spool slip off the motor cover. The spool assembly(12) is not fixed yet.

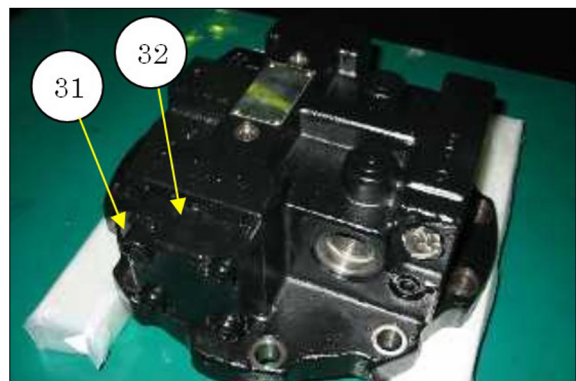

11078TM101

(28) Put O-ring(30) on plug(25). Install plug (25) to the brake valve. Tighten the plug(25) to a torque of  $78.5 \pm 7.8 \text{ N} \cdot \text{m}$  ( $57.9 \pm 5.8 \text{ lbf} \cdot \text{ft}$ ).

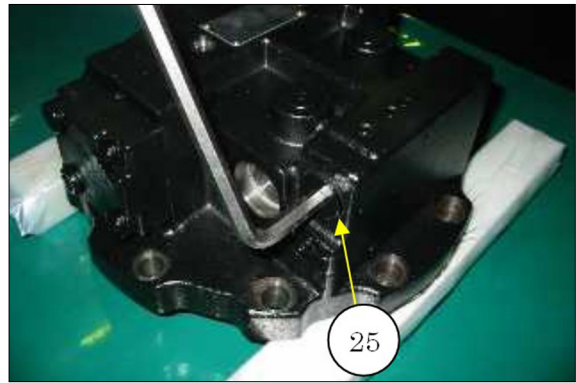

11078TM104

(29) Install rod(28), spring guide(27) and spring(26) to the brake valve.

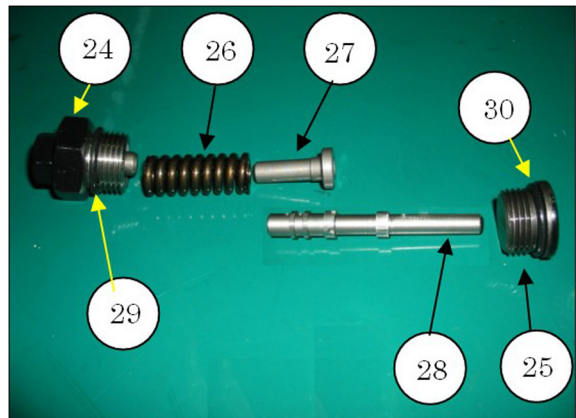

11078TM102

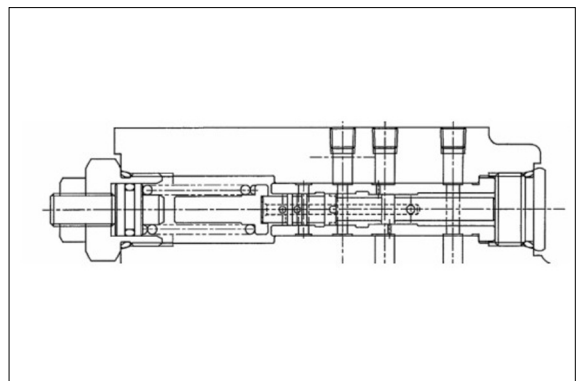

11078TM103

(30) Put O-ring(29) on plug assembly(24). Install plug assembly(24) to the brake valve. Tighten the plug assembly(24) to a torque of  $78.5 \pm 7.8 \text{ N} \cdot \text{m}$  ( $57.9 \pm 5.8 \text{ lbf} \cdot \text{ft}$ ).

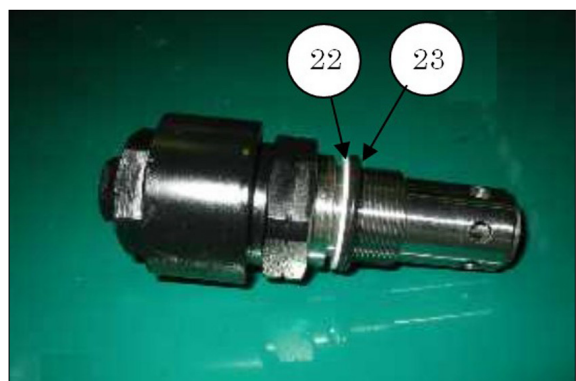

11078TM106



(31) Install back-up ring(22) and O-rings(23) on the relief valve as shown.

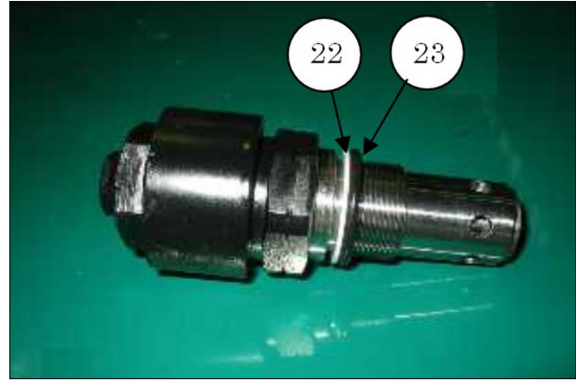

11078TM106

(32) Install relief valve(21) in the travel brake valve body as shown. Tighten the relief valve body to a torque of  $196 \pm 19.6 \text{ N} \cdot \text{m}$  ( $145 \pm 14.5 \text{ lbf} \cdot \text{ft}$ ).

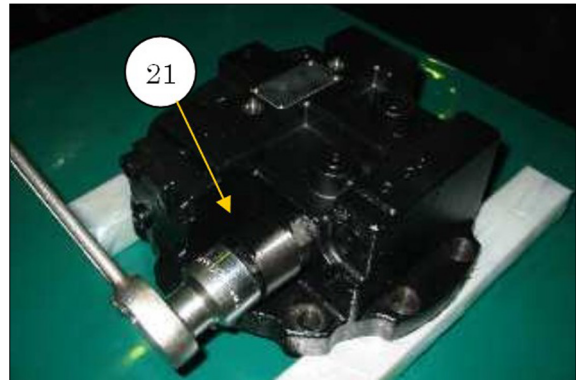

11078TM107

(33) Install two balls(20) in the brake valve. Put O-rings(19) on plugs(18). Install the plugs to the travel brake valve. Tighten the plugs to a torque of  $19.6 \pm 2.0 \text{ N} \cdot \text{m}$  ( $14.5 \pm 1.5 \text{ lbf} \cdot \text{ft}$ ).

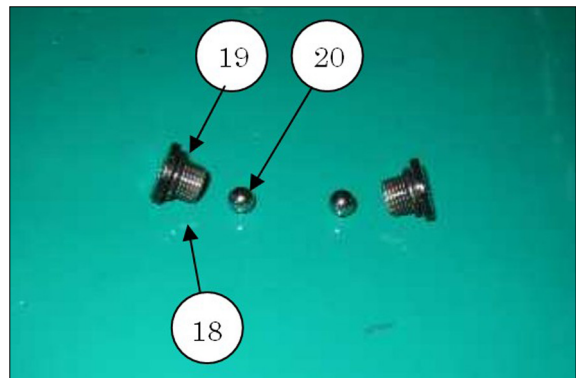

11078TM108

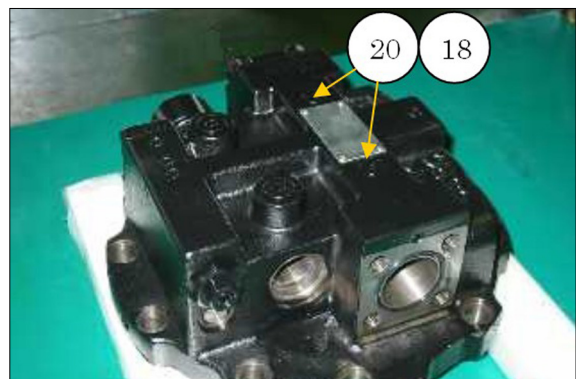

11078TM109

(34) Put spool(17), spring(16), and stopper(15) in the brake valve body. Put the O-ring on plug(14). Install plug(14) to the travel brake valve. Tighten the plug to a torque of  $49 \pm 4.9\text{N} \cdot \text{m}$  ( $36.1 \pm 3.6\text{lb} \cdot \text{ft}$ ).

Put O-ring(13) on the brake valve body.

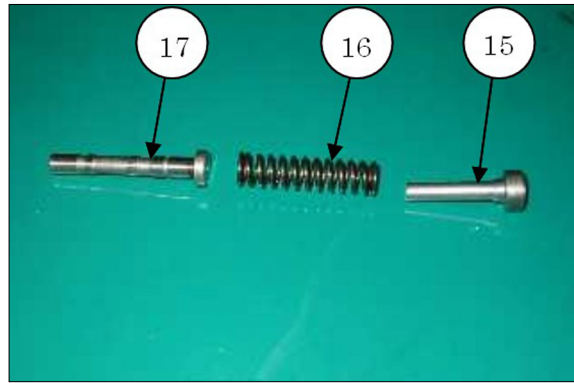

11078TM110

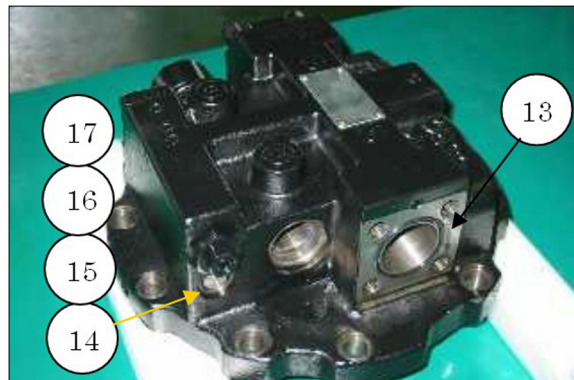

11078TM111

(35) Install plate(11) and then spring(10) in the brake valve. Then, install cover(9) with four bolts(8). Tighten the bolts(8) to a torque of  $78.5 \pm 7.8\text{N} \cdot \text{m}$  ( $57.9 \pm 5.8\text{lb} \cdot \text{ft}$ ).

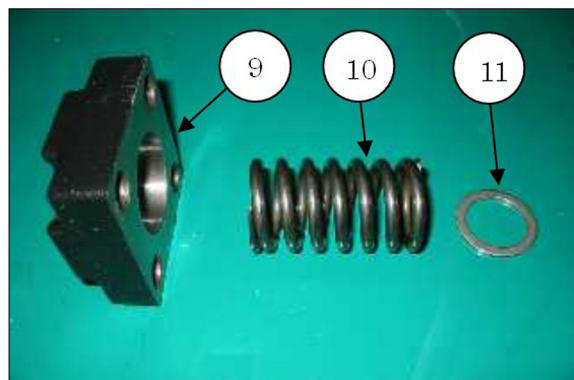

11078TM112



11078TM113

- (36) Put the brake valve upside-down.  
Install valve plate(33) in its original position on the brake valve.  
Put some clean hydraulic oil on the valve plate surface.



11078TM114

- (37) Position brake valve(3) on the body casing. Install ten bolts(2) that hold it.  
Tighten the bolts to a torque of  $191 \pm 14.7$  N · m ( $141 \pm 10.8$  lbf · ft).

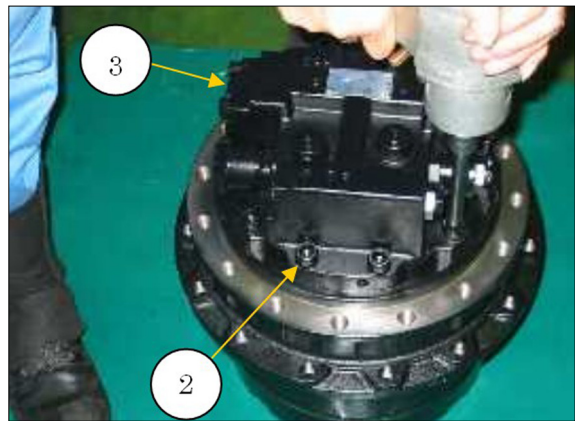

11078TM115

- (38) Install back-up ring(6) and O-ring(7) on the relief valve.

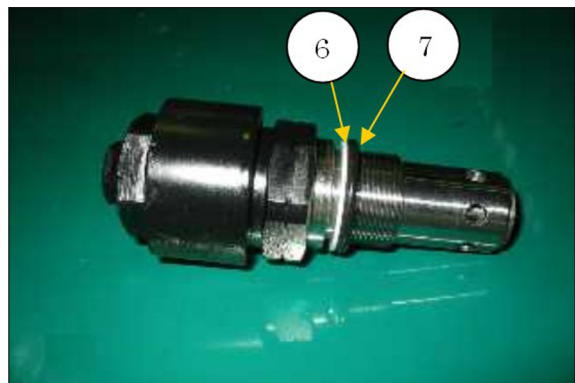

11078TM116

- (39) Install relief valve(1) to travel brake valve (3).  
Tighten the relief valve body to a torque of  $196 \pm 19.6$  N · m ( $145 \pm 14.5$  lbf · ft).

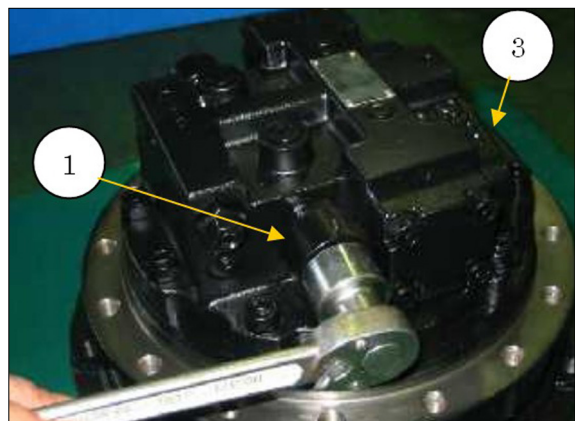

11078TM117

(40) Place the travel motor with brake valve upside down as shown. Apply torque to shaft(90) to confirm the parking brake torque. If the shaft starts rotating by a torque of more than **239N · m (176lb · ft)**, it satisfies the spec. If the motor output shaft rotates at a less torque than above, shim(40) needs to be replaced with thicker one in order to get a higher parking brake torque.

There are some variations of thickness available for shim(40). The thicker the shim is, the higher the parking brake torque is. The thinner the shim is, the lower the parking torque is.

**▲ Don't apply too thick shim to the travel motor. It may cause damage to braking parts because of malfunction in brake-releasing action in traveling.**

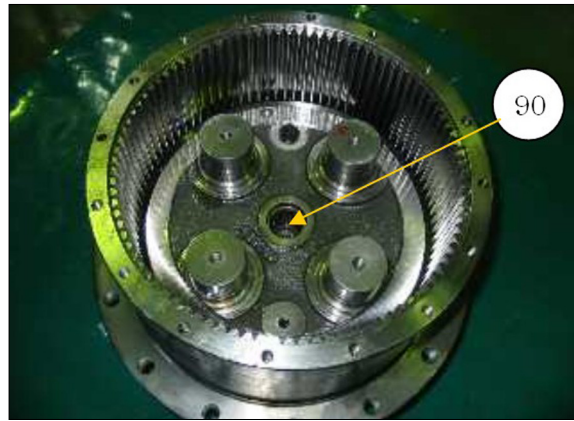

11078TM118

(41) Install four plates(80), four bushes(79), four bearings(78) and four planetary gears(77) as shown.

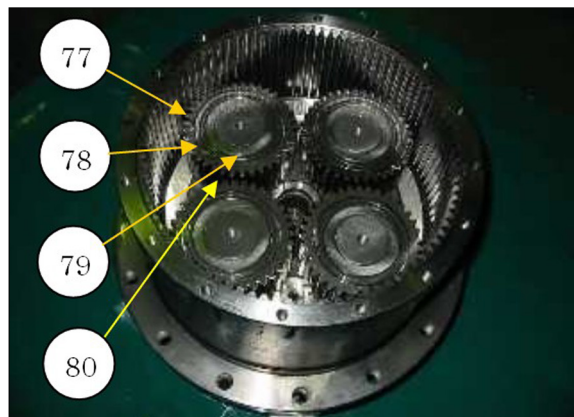

11078TM119

(42) Install snap ring(74) to sun gear(73).

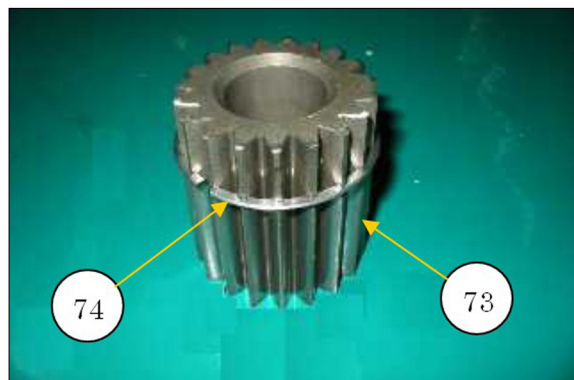

11078TM120

- (43) Put thrust plate(76) as shown. Apply **Thread Lock "THREE BOND 2403"** to bolts(75). Install four bolts(75). Tighten the bolts to a torque of  $68.6 \pm 4.9$  N · m ( $50.6 \pm 3.6$  lbf · ft). Then install sun gear(73).

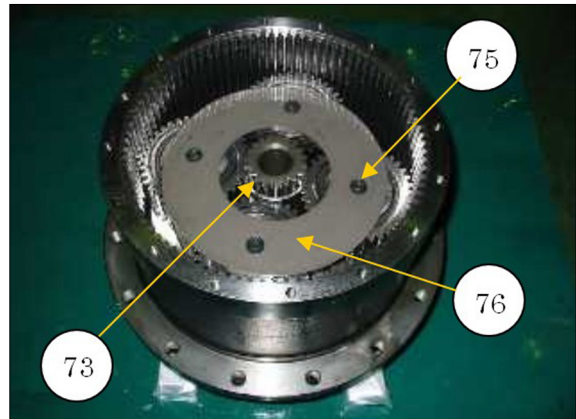

11078TM121

- (44) Install three inner races(72) on the carrier shaft.

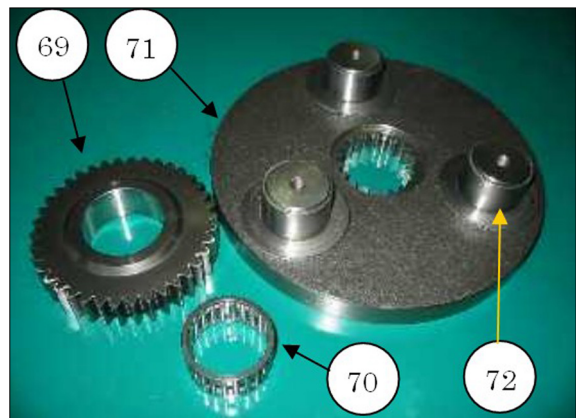

11078TM122

- (45) Install carrier(71) as shown.



11078TM123

- (46) Install three bearings(70) and three planetary gears(69) on the carrier shaft assembly. Then install sun gear(68).

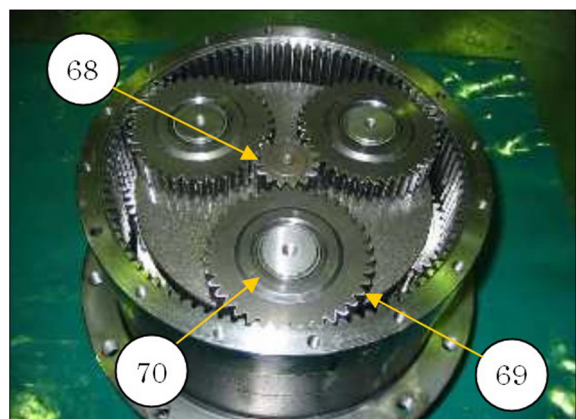

11078TM124

- (47) Put thrust plate(67) on the carrier. Apply **Thread Lock "THREE BOND 2403"** to bolts(66). Install three bolts(66) that hold plate(67) to the planetary carrier. Tighten the bolts to a torque of **68.6 ± 4.9 N · m (50.6 ± 3.7 lbf · ft)**.

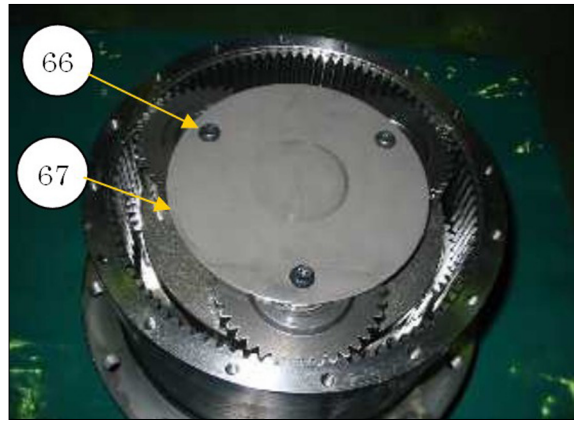

11078TM125

- (48) Make sure the machined surface of gear casing(65) and cover(64) is completely clean, free of dirt and debris, and is dry. Put a bead of **Gasket Maker "THREE BOND 1389"** around the machined surface of the gear casing as shown. Put cover(64) in its original position on the gear casing.

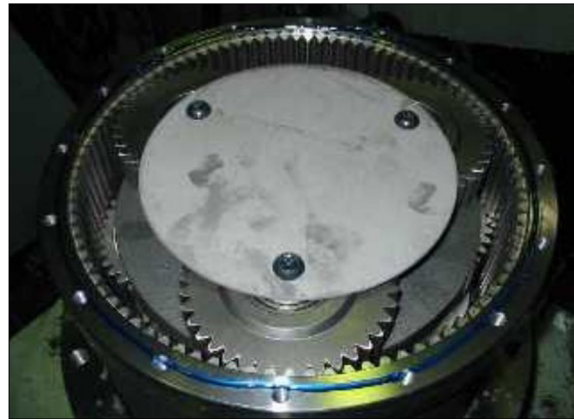

11078TM126

- (49) Install sixteen bolts(62) and sixteen washers(63) that hold the cover. Tighten the bolts to a torque of **35.3 ± 2 N · m (26 ± 1.5 lbf · ft)**.

Install lubricating oil from the drain port. The capacity of the travel motor is **2.5 liters (0.55 U.K. gal; 0.66 U.S. gal)**.

- ⚠ To prevent damage to the motor, the case of the motor must be filled with hydraulic oil before operation.

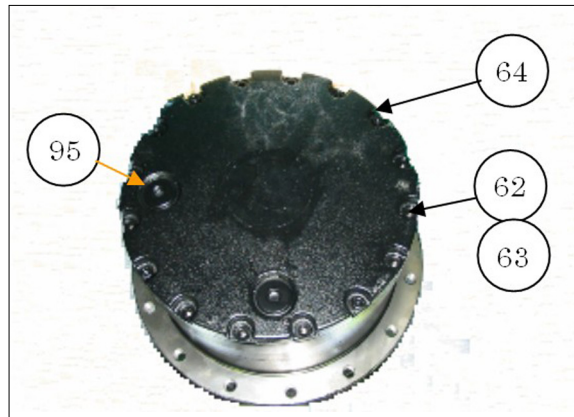

11078TM127

This is the end of assembling process