

## GROUP 5 SWING DEVICE

### 1. REMOVAL AND INSTALL OF MOTOR

#### 1) REMOVAL

- (1) Lower the work equipment to the ground and stop the engine.
- (2) Operate the control levers and pedals several times to release the remaining pressure in the hydraulic piping.
- (3) Loosen the breather slowly to release the pressure inside the hydraulic tank.

**▲ Escaping fluid under pressure can penetrate the skin causing serious injury.**

※ When pipes and hoses are disconnected, the oil inside the piping will flow out, so catch it in oil pan.

- (4) Disconnect hose assembly(2).
- (5) Disconnect pilot line hoses(4,5,6,7,8,9).
- (6) Sling the swing motor assembly(1) and remove the swing motor mounting bolts (10).

※ Motor device weight : 36kg(79.4lb)

- (7) Remove the swing motor assembly.  
※ When removing the swing motor assembly, check that all the piping have been disconnected.

#### 2) INSTALL

- (1) Carry out installation in the reverse order to removal.
- (2) Bleed the air from the swing motor.
  - ① Remove the air vent plug.
  - ② Pour in hydraulic oil until it overflows from the port.
  - ③ Tighten plug lightly.
  - ④ Start the engine, run at low idling and check oil come out from plug.
  - ⑤ Tighten plug fully.
- (3) Confirm the hydraulic oil level and check the hydraulic oil leak or not.

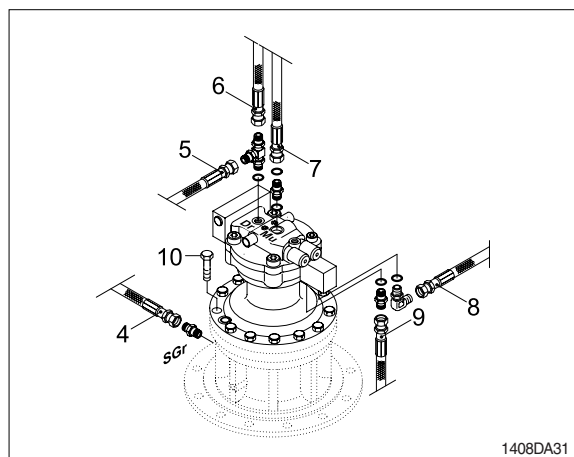
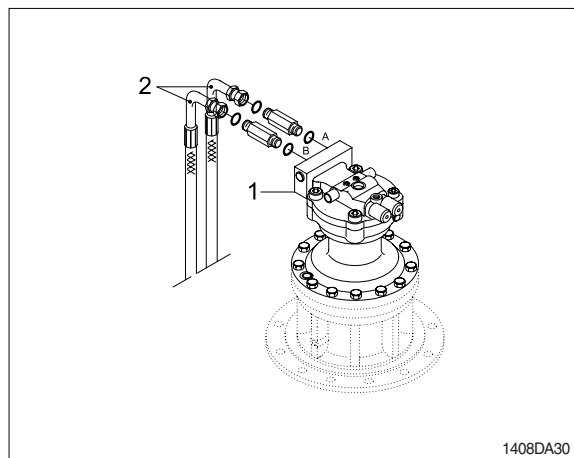

## 2. DISASSEMBLY AND ASSEMBLY OF SWING MOTOR

### 1) STRUCTURE

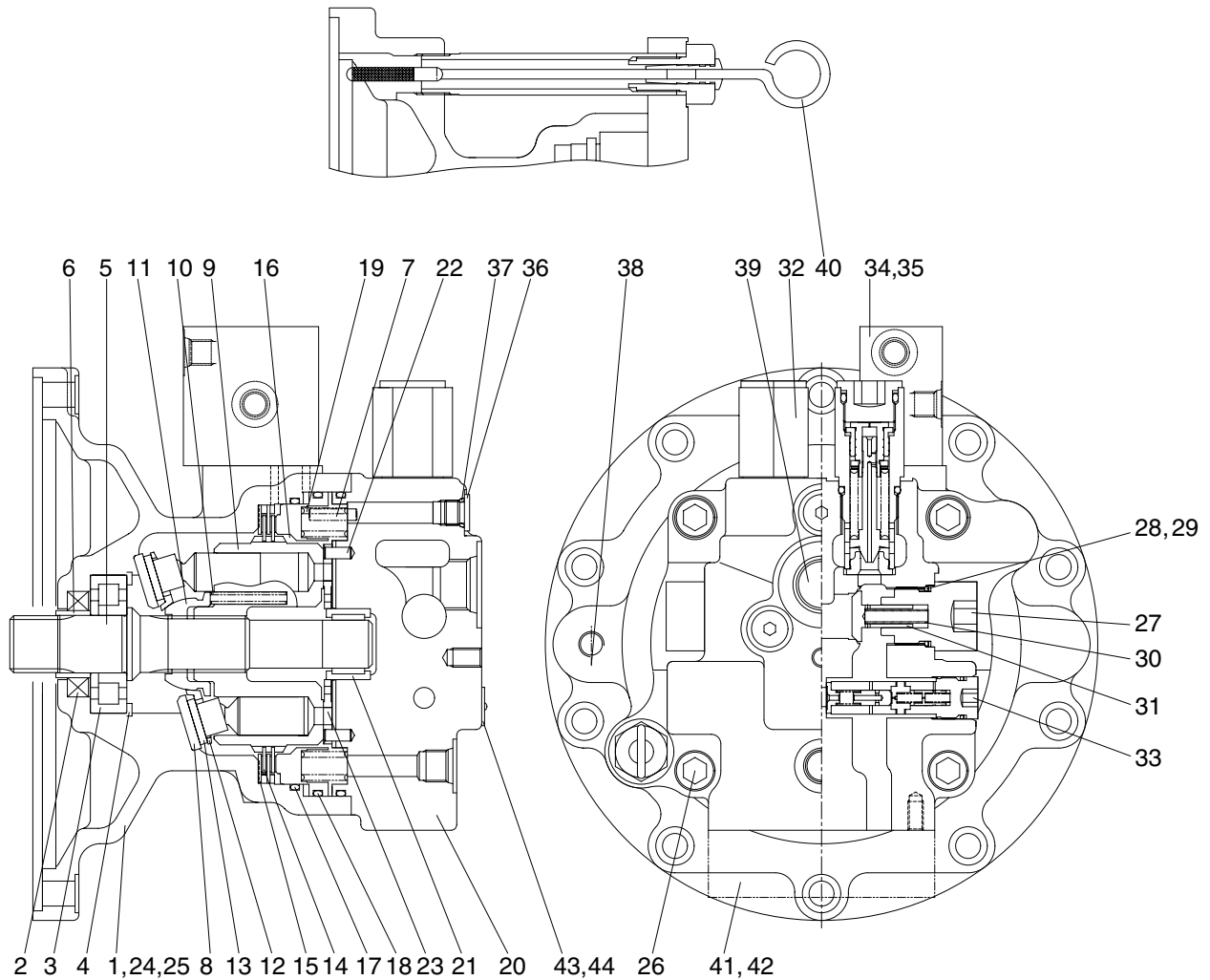

1407A2SM02

1	Body	17	O-ring	33	Anti-rotating valve
2	Oil seal	18	O-ring	34	Time delay valve
3	Roller bearing	19	Spring	35	Wrench bolt
4	Snap ring	20	Rear cover	36	Plug
5	Shaft	21	Needle bearing	37	O-ring
6	Bushing	22	Pin	38	Plug
7	Pin	23	Valve plate	39	Plug
8	Shoe plate	24	O-ring	40	Level gauge
9	Cylinder block	25	O-ring	41	Flange
10	Spring	26	Wrench bolt	42	O-ring
11	Ball guide	27	Plug	43	Name plate
12	Set plate	28	Back up ring	44	Rivet
13	Piston assembly	29	O-ring	45	Plug
14	Friction plate	30	Spring	46	O-ring
15	Plate	31	Check	47	O-ring
16	Brake piston	32	Relief valve	48	Black up ring

## 2) DISASSEMBLY

- (1) Lift the motor out. Clean the motor in kerosene and dry with compressed air.
  - ※ To avoid dust inside the motor, mask all the ports of the motor with tapes.

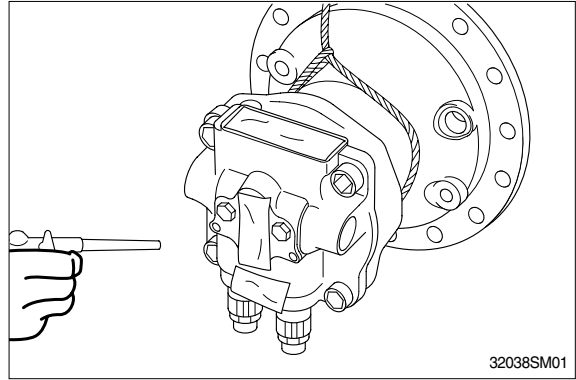

- (2) Loosen the drain plug to discharge oil in the body(1).

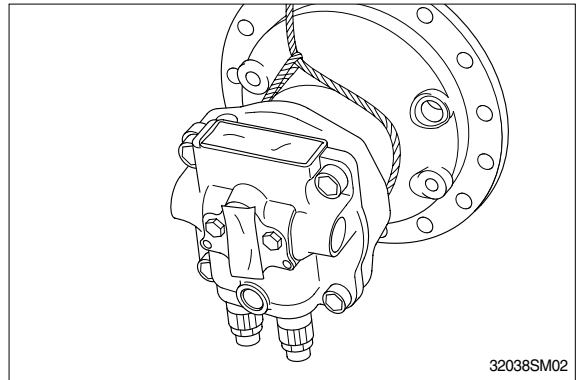

- (3) Fix the drive shaft (5) on the workbench with the end of output shaft down. Put matching marks on body (1) and valve rear cover (20) for easy reassembly.

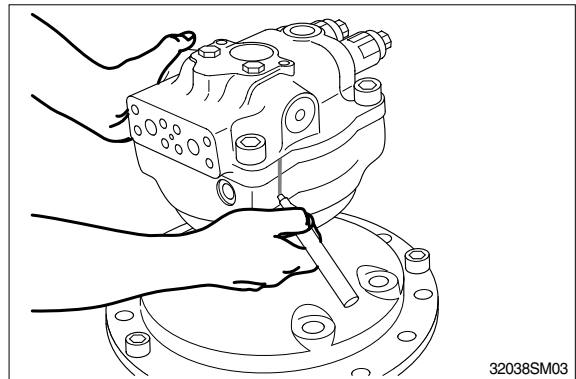

- (4) Remove the valve (34).

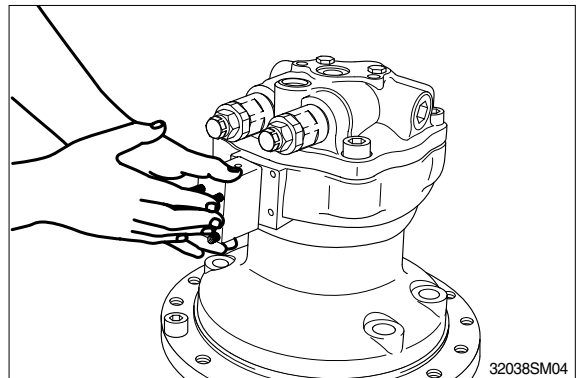

- (5) Remove the relief valve (32) from rear cover (20).

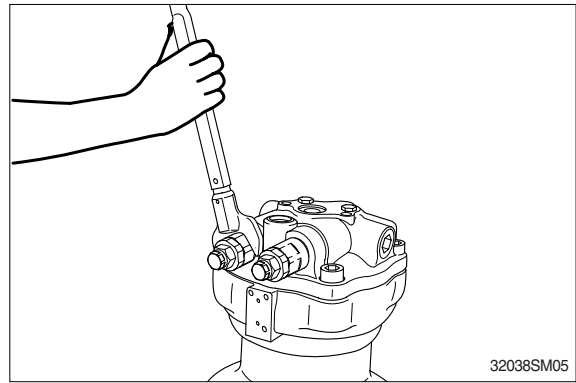

- (6) Remove plug (27) from rear cover (20) and spring (30), check (31).  
※ Be careful not to damage the check seat assembly.

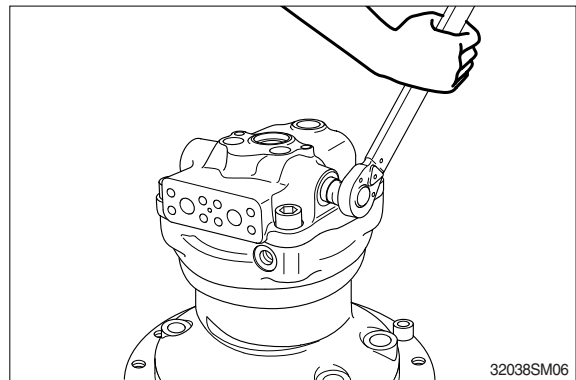

- (7) Remove rear cover (20) from body (1). Then, remove the valve plate (23) from rear cover (20) with care.

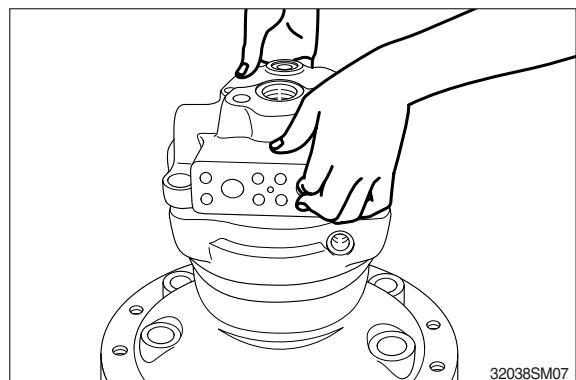

- (8) Remove the brake spring (19) from brake piston (16).

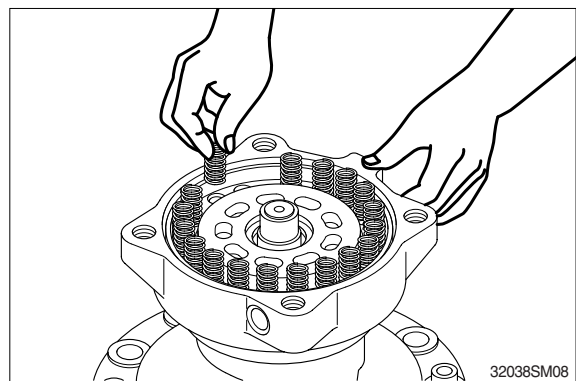

(9) Remove brake piston (16) from body (1).

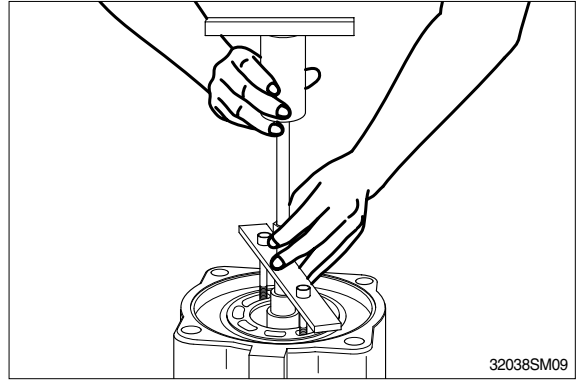

(10) Remove the cylinder (9) from the output shaft (5) with the motor positioned horizontally. Remove ball guide (11), set plate (12), piston (13) and shoe plate (8).

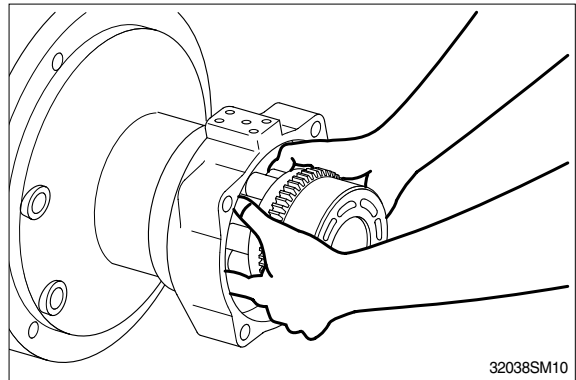

(11) Remove friction plate (14) and separate plate (15) from body (1).

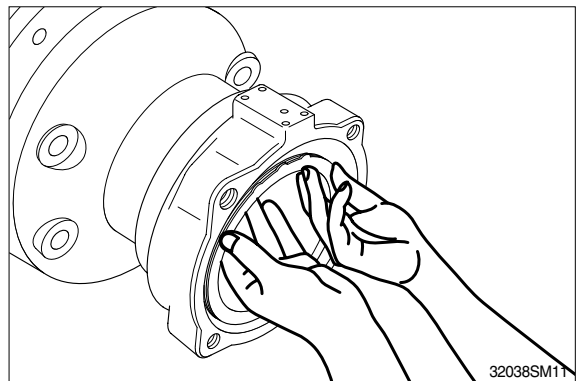

(12) Remove snap ring (4) and remove drive shaft (5) from body (1).

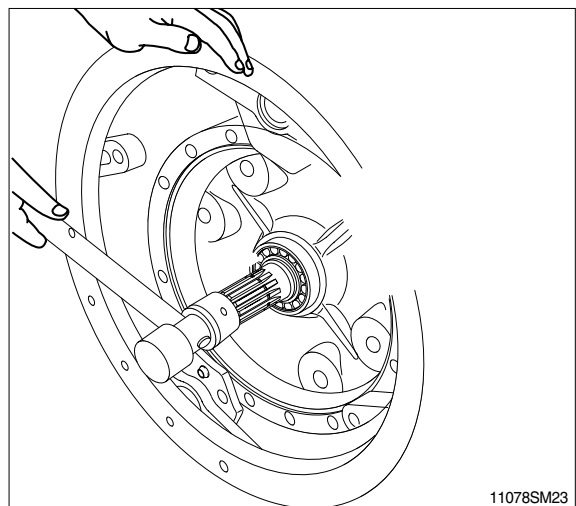

(13) Remove the cone of roller bearing (3) by press.

※ Do not reuse bearings.

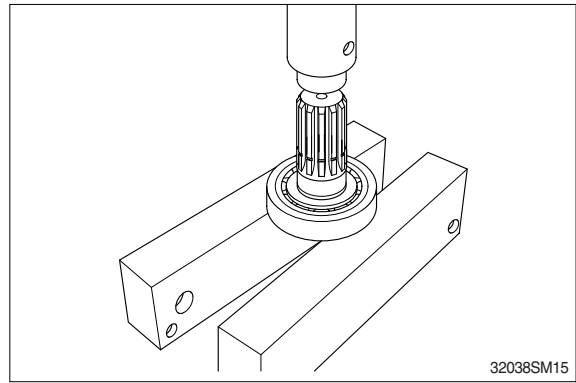
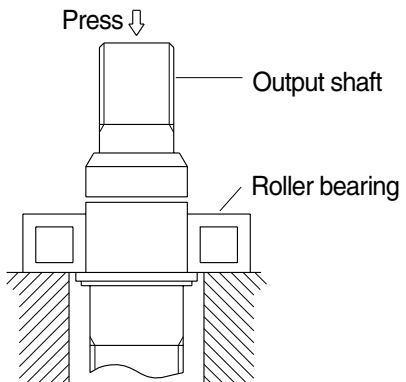

(14) Remove bushing (6) and oil seal (2) from body (1).

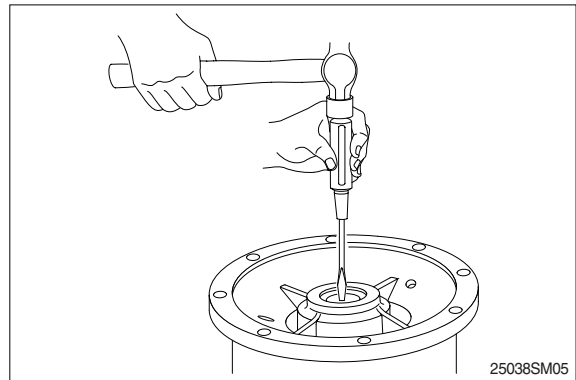

(15) Remove the needle bearing (21) from the rear cover (20) by using slide hammer bearing puller.

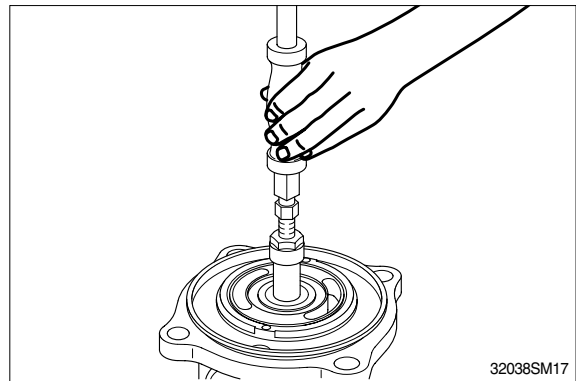

(16) When disassembling the relief valve, release the plug (3).

Remove the piston (7), spring seat (9), spring (8) and plunger (6) with the body (1) downwards.

※ Do not release the lock nut (15).

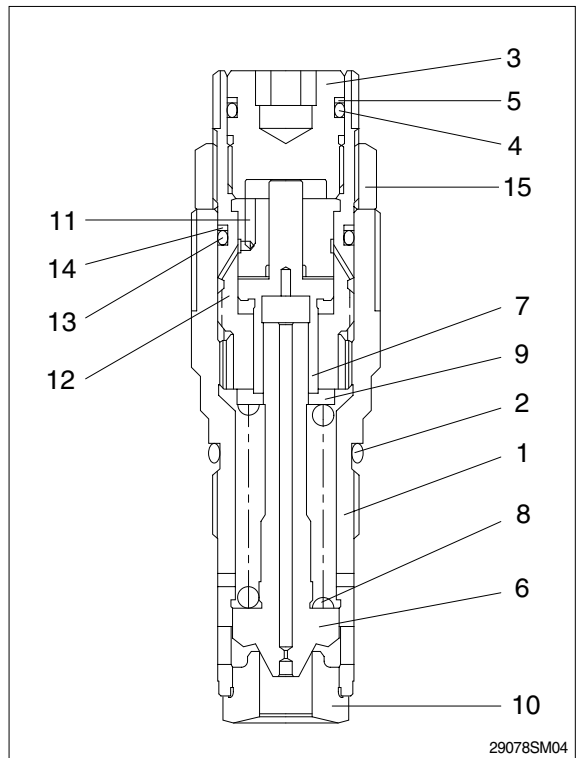

This completes disassembly.

### 3) ASSEMBLY

Do the reassembly in the reverse procedure of the disassembly.

- (1) Apply three bond of white color on outer surface of oil seal (2) and insert it to the body (1).

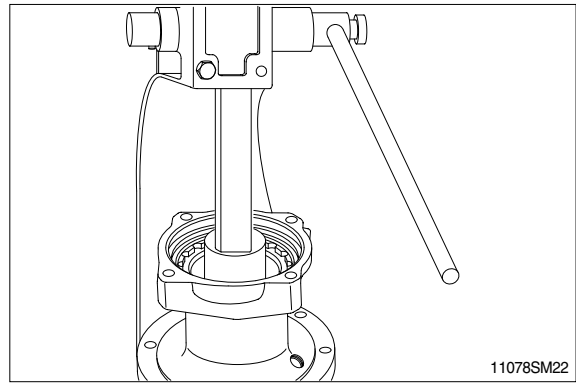

- (2) Install the roller bearing (3) to the drive shaft (5).

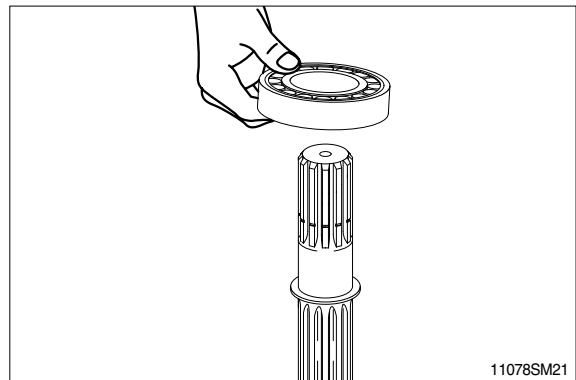

- (3) Insert the drive shaft (5) into the body (1) with the plastic hammer lightly.

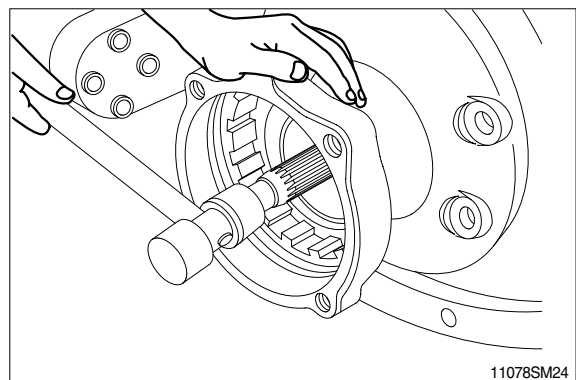

- (4) Install the snap ring (4) to the body (1).

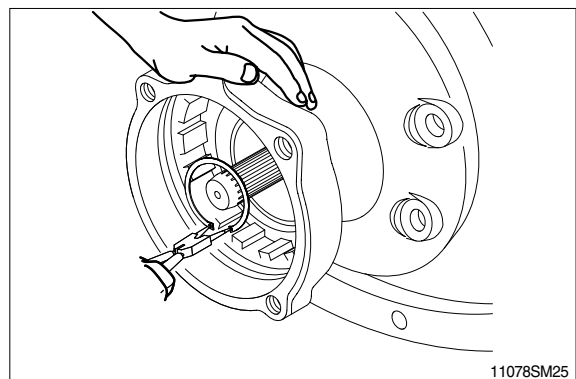



- (5) Insert the shoe plate (8) with the body (1) position horizontally.

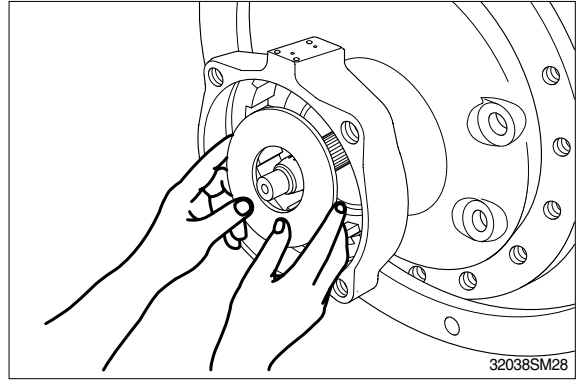

- (6) Insert the ball guide (11) into the cylinder (9).

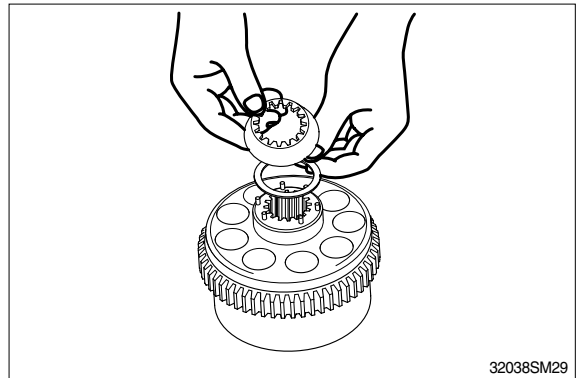

- (7) Install the piston sub-assembly (13) to the set plate (12).



- (8) Reassemble the piston assembly (9) to the body (1).

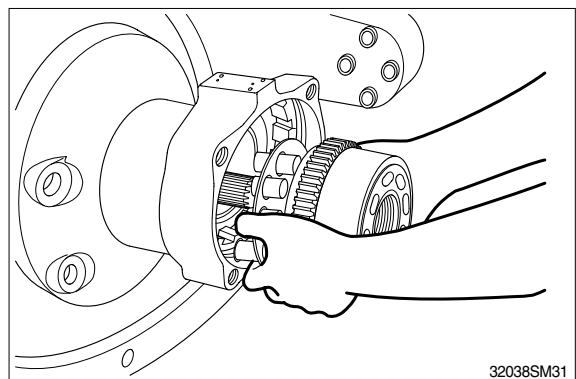

(9) Assembly friction plate (14) and plate (15) to the body (1).

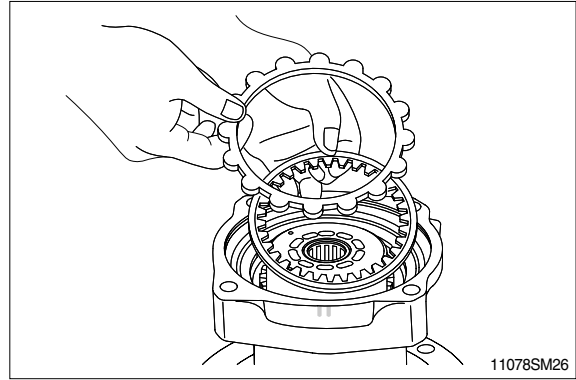

(10) Insert O-ring (17) inside the body (1).

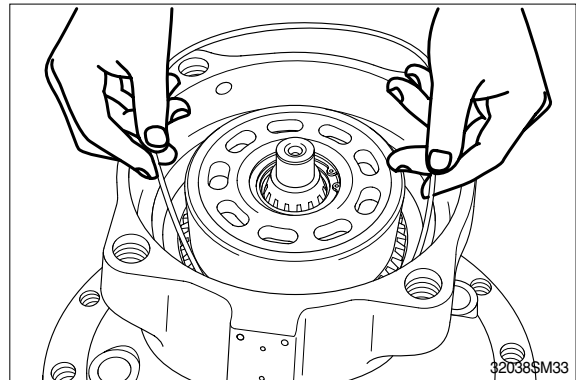

(11) Reassemble brake piston (16) to the body (1).

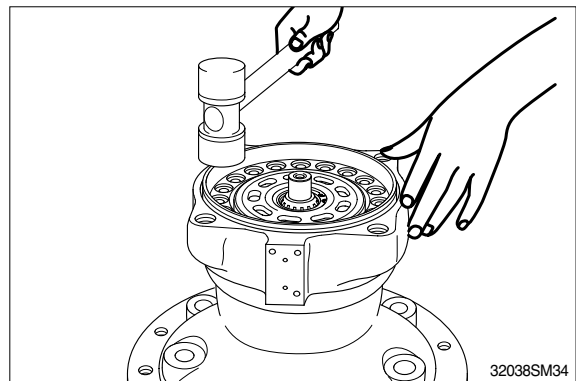

(12) Reassemble brake spring (19) to the brake piston (16).

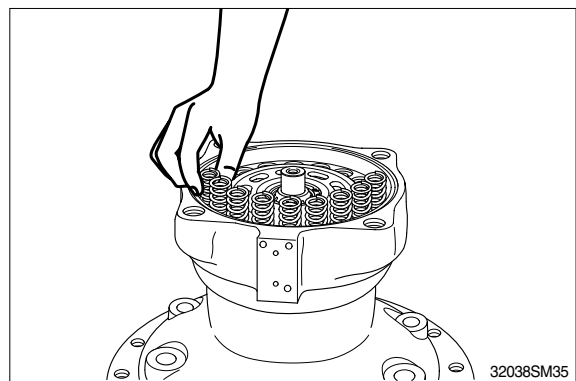

- (13) When assembling the needle bearing (21), insert the needle bearing (21) into rear cover (20) by hammering.

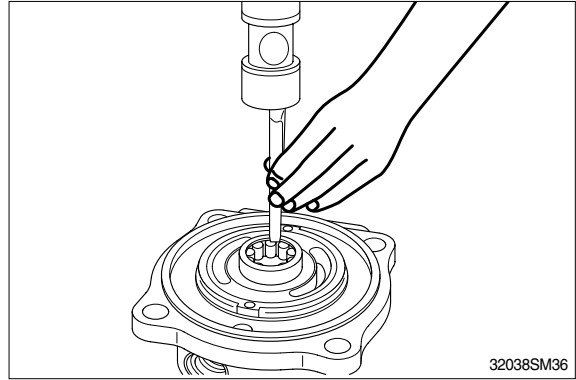

- (14) Reassemble valve plate (23) to the rear cover (20) and reassemble O-ring (18).

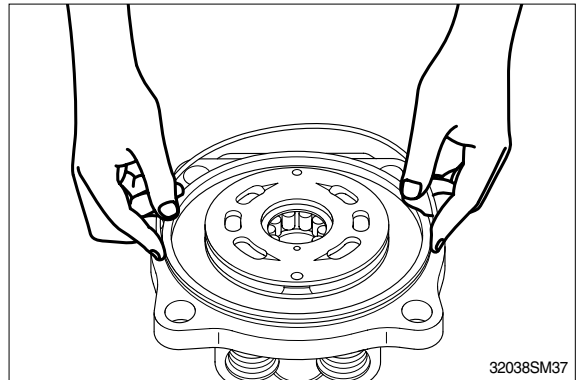

- (15) Connect the rear cover (20) with the body (1) and tighten the wrench bolt (26).

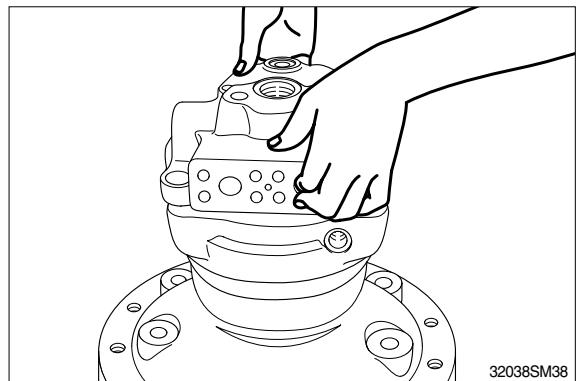

- (16) Insert check (31) and spring (30) in the valve casing and install O-ring (29) and back up ring (28). Tighten plug (27) to the rear cover (20).

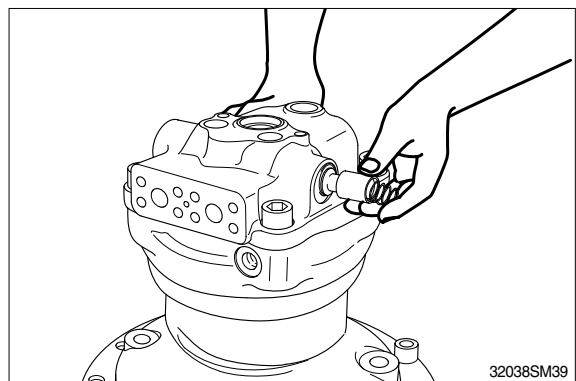

(17) Insert O-rings to the relief valve (32) and reassemble them to rear cover (20).

This completes assembly.

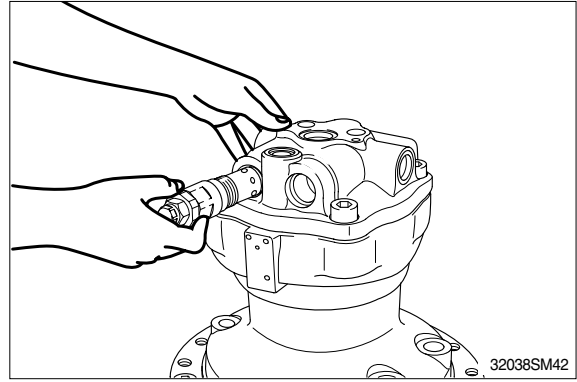

### 3. REMOVAL AND INSTALL OF REDUCTION GEAR

#### 1) REMOVAL

- (1) Remove the swing motor assembly.  
For details, see **removal of swing motor assembly**.
- (2) Sling reduction gear assembly (1) and remove mounting bolts (2).
- (3) Remove the reduction gear assembly.
  - Reduction gear device weight : 95kg  
(209lb)



#### 2) INSTALL

- (1) Carry out installation in the reverse order to removal.
  - Tightening torque :  $29.6 \pm 3.2 \text{kgf} \cdot \text{m}$   
( $215 \pm 23.1 \text{lbf} \cdot \text{ft}$ )

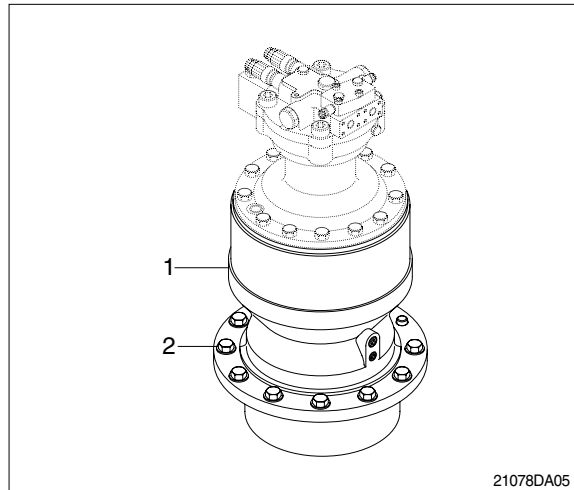

## 4. DISASSEMBLY AND ASSEMBLY OF REDUCTION GEAR

### 1) STRUCTURE

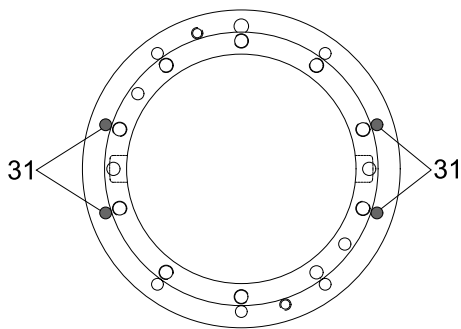
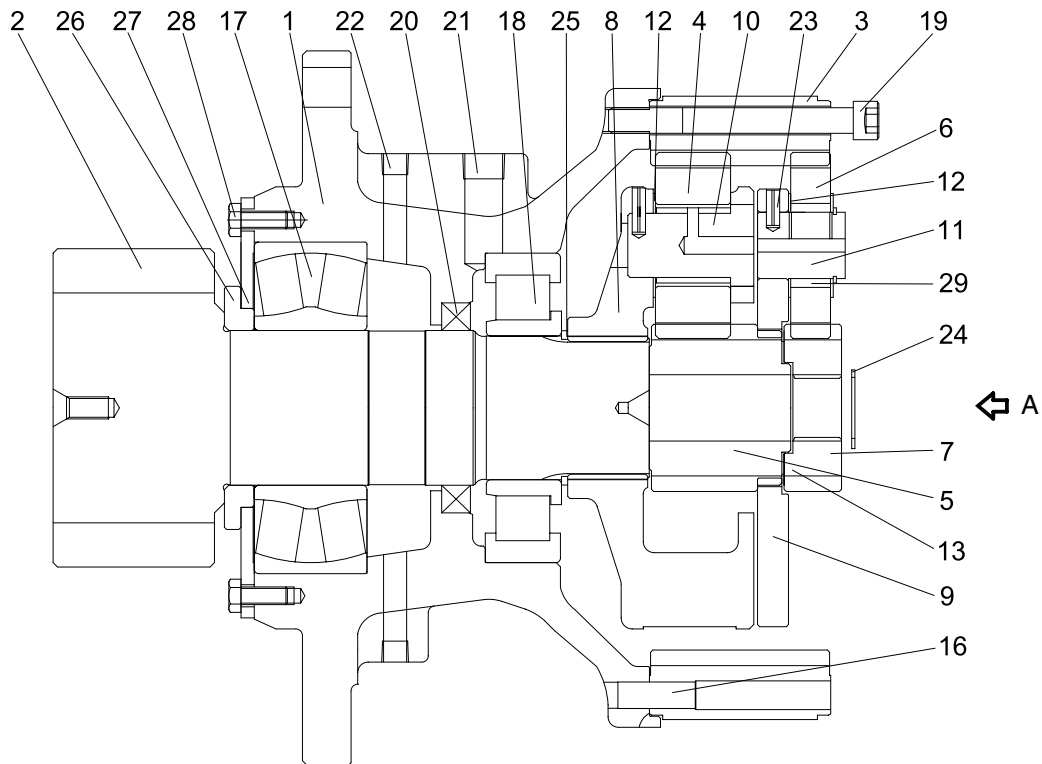

VIEW A

1407A2SM03

1	Casing	11	Pin No.1	22	Plug(A)
2	Drive shaft	12	Thrust washer(B)	23	Spring pin
3	Ring gear	13	Side plate No. 1	24	Stop ring
4	Planet gear No.2	16	Knock pin	25	Stop ring
5	Sun gear No.2	17	Sph roller bearing	26	Spacer
6	Planet gear No.1	18	Cyl roller bearing	27	Cover plate
7	Sun gear No.1	19	Socket head bolt	28	Bolt
8	Carrier No.2	20	Oil seal	29	Needle cage
9	Carrier No.1	21	Plug(B)	31	Rubber cap
10	Pin No.2 assembly				

## 2) DISASSEMBLY

- (1) Remove gauge bar (40) and gauge pipe (15) from the swing motor casing.
- ※ Pour the gear oil out of reduction gear into the clean bowl to check out the friction decrease.

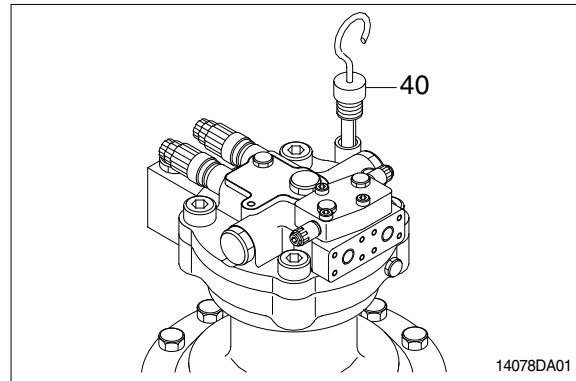

- (2) Loosen the socket bolts (19) to separate swing motor from reduction gear.

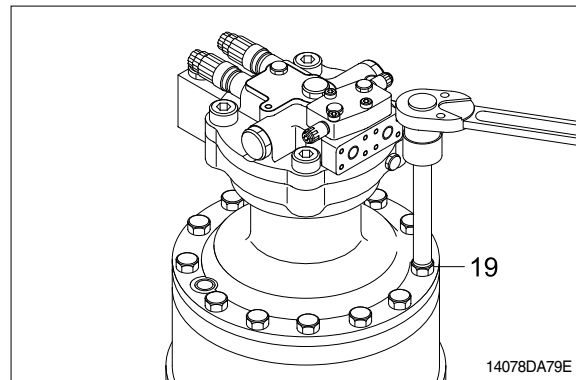

- (3) Remove stop ring (24) and then sun gear 1 (7).

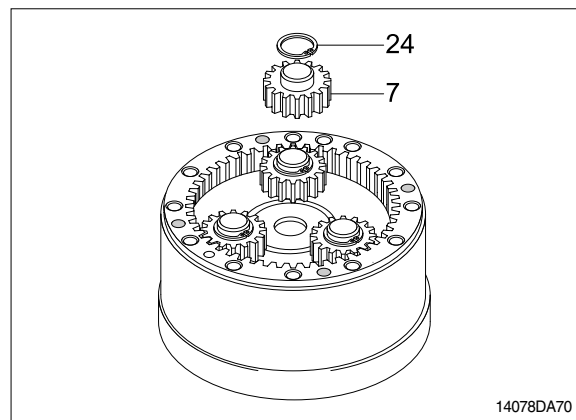

- (4) Tighten two M10 eye bolts to carrier 1 (9) and lift up and remove carrier 1 (9) as subassembly.

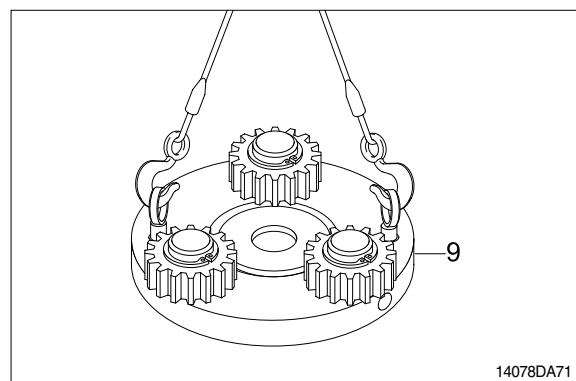

(5) Disassembling carrier 1 (9) assembly.

- ① Remove stop ring (24).
  - ② Remove thrust washer (12), planet gear 1(6), needle cage (29), and thrust washer (12) from the carrier.
  - ③ Using M8 solid drill, crush spring pin (23) so that the pin 1 (11) can be removed by hammering.
- ※ Do not reuse spring pin (23).
  - ※ Do not remove pin 1 (11), carrier1 (9) and spring pin (23) but in case of replacement.
  - ※ Put matching marks on the planet gear 1 (6) and the pin1 (11) for easy reassembly.

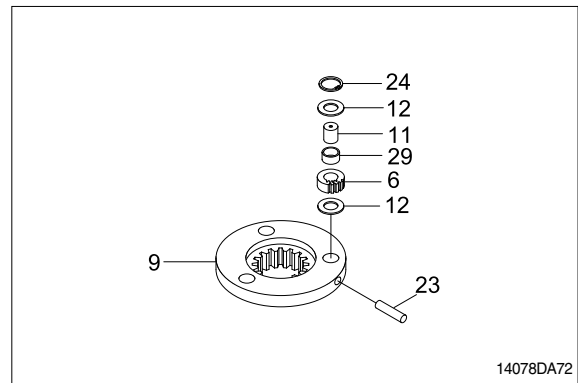

(6) Remove sun gear 2 (5) and side plate (13).

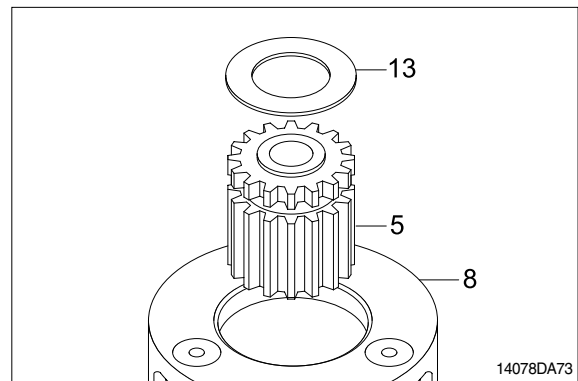

(7) Remove carrier 2 (8) assembly from casing (1).

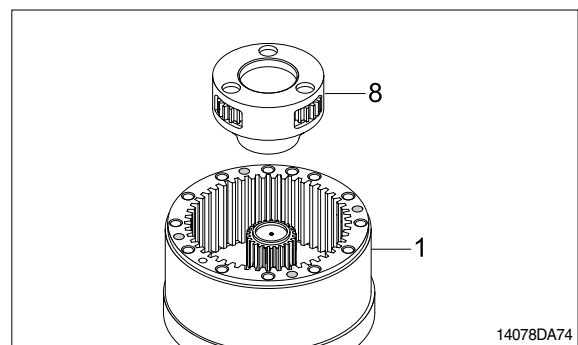



(8) Disassembling carrier 2 (8) assembly

- ① Using M8 solid drill, crush spring pin (23) so that the pin 2 (10) can be removed.
  - ※ Do not reuse spring pin (23).
- ② Remove pin 2 (10), planet gear 2 (4) and thrust washer (12) from the carrier 2 (8).
  - ※ Put matching marks on the planet gear 2 (4) and the pin 2 (23) for easy reassembly.
  - ※ Do not disassemble pin 2 (23), carrier 2 (8) and spring pin 2 (23) but in case of replacement.

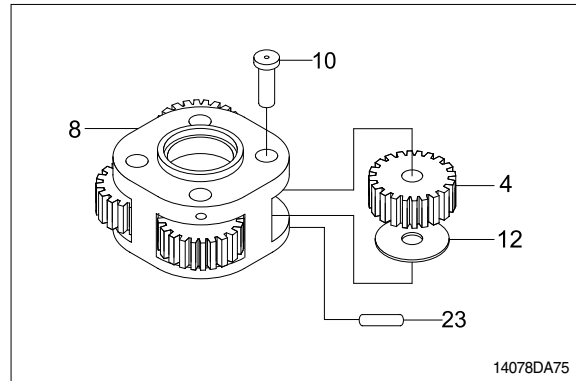

(9) Tighten two M16 eyebolt to the ring gear (3) and then lift the ring gear (3) out of casing (1).

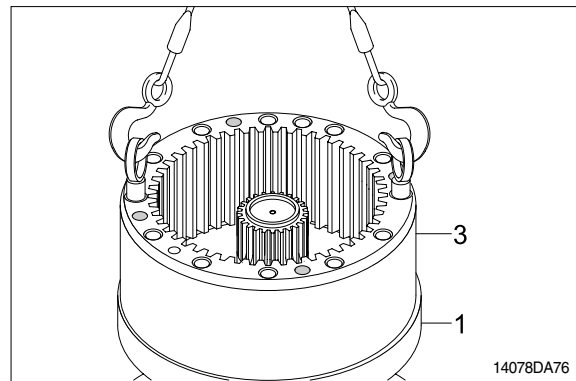

(10) Remove stop ring (25) from the drive shaft (2).

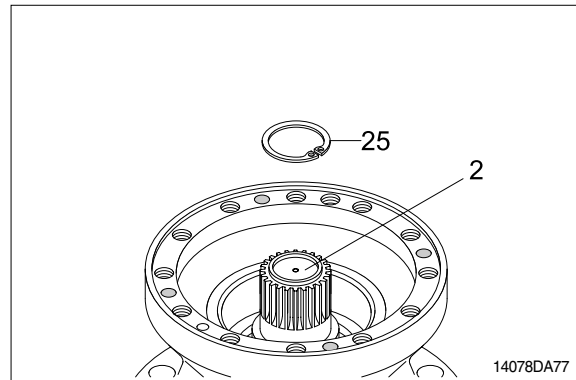

(11) Remove drive shaft (2) with roller bearing (18) and oil seal (20) assembled. Remove knock pin (16) from the casing (1).

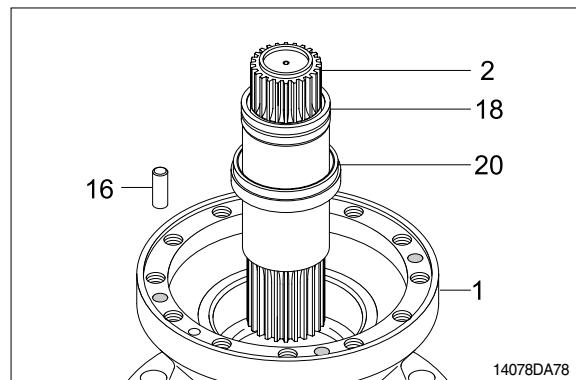

- (12) Remove roller bearing (18) and oil seal (20) from the drive shaft (2).  
※ Do not reuse oil seal (20) once removed.

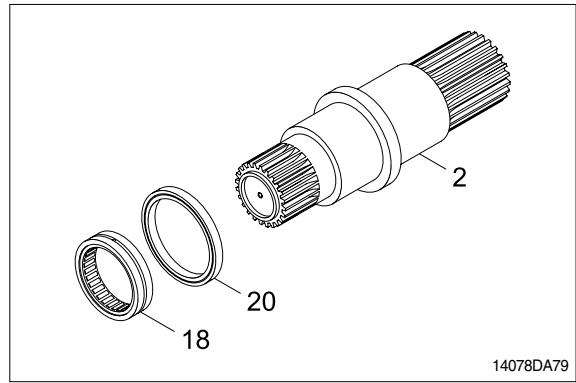

- (13) Using the bearing disassembly tool, remove roller bearing (17).

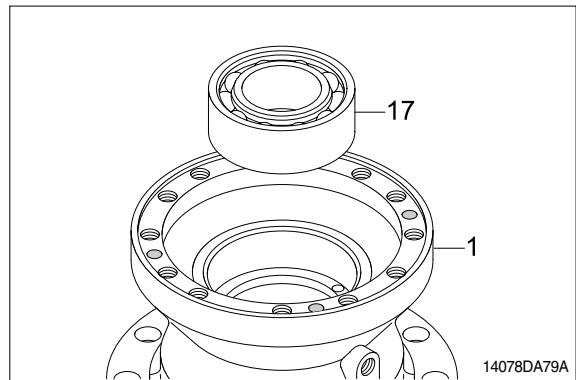

- (14) Remove plugs (21, 22) from the casing (1).

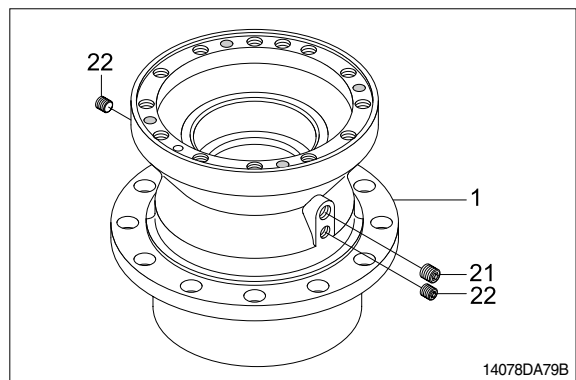

### 3) ASSEMBLY

- (1) Assemble roller bearing (17) inside the casing (1).

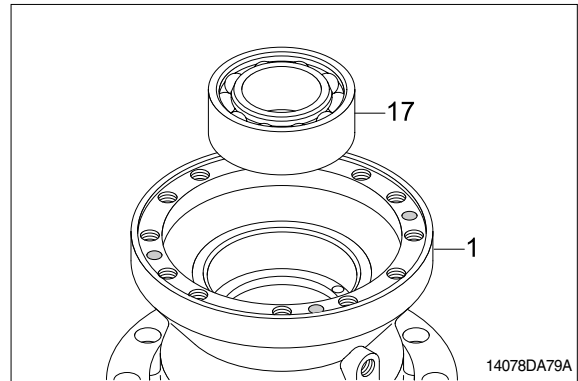

- (2) Assemble the drive shaft (2) into the casing (1) and then install oil seal (20) and roller bearing (18).

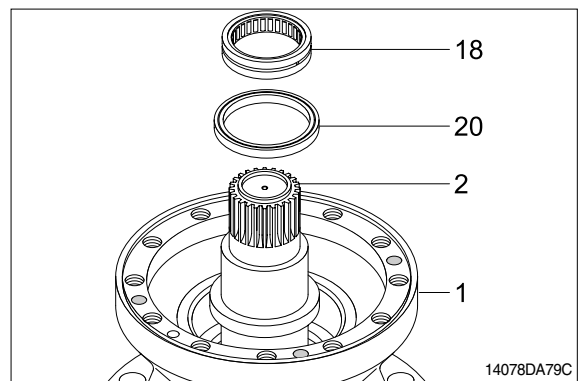

- (3) Install stop ring (25) on top of drive shaft (2).

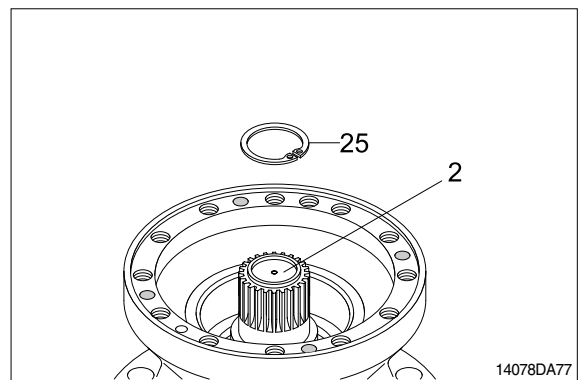

- (4) Apply loctite to the tapped holes of casing (1).

- (5) Tighten 2 M16 eye bolts to the ring gear (3) and lift up and then assemble it onto the casing (1).

※ Don't fail to coincide the knock pin (16) holes.

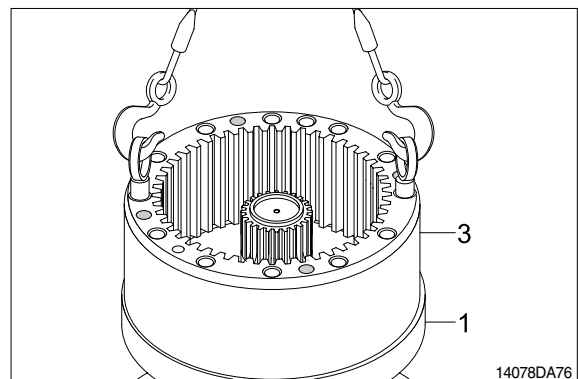

(6) Assembling carrier 2 (8) assembly.

- ① Install thrust washer (12) and the planet gear 2 (4) inside the carrier 2 (8).
  - ② Assemble the pin 2 (10) to the carrier 2 (8) and then press the spring pin (23) by hammering.
  - ③ Punch 2 points of the spring pin (23) lip.
- ※ Take care not to mistake the matching marks of each part.

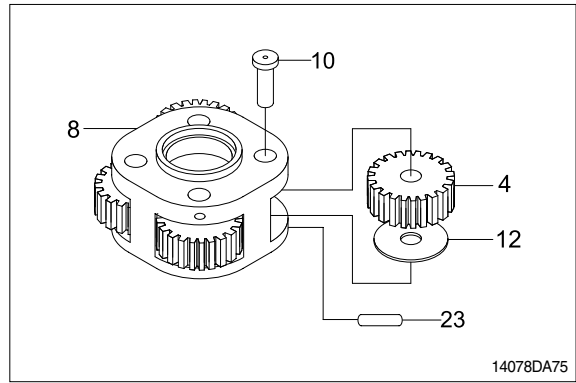

(7) Assemble carrier 2 (8) assembly correctly to the drive shaft (2).

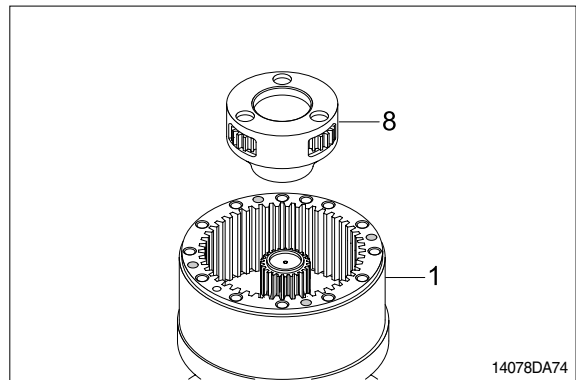

(8) Assemble sun gear 2 (5) and thrust gear (13) to the center of the carrier 2 (8) assembly.

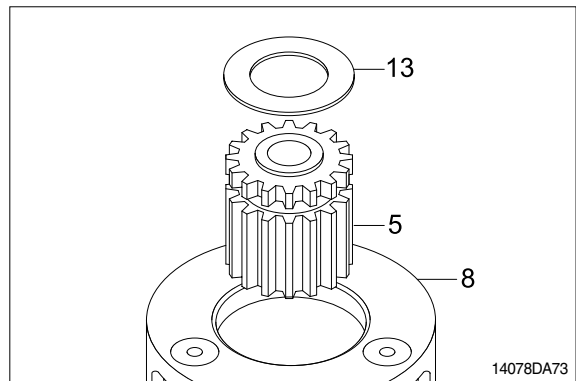

(9) Assembling carrier 1 (9) assembly.

- ① Assemble the pin1 (11) to the carrier 1 (9) and then press the spring pin (23) by hammering.
  - ② Punch 2 points of the spring pin's (23) lip.
  - ③ Install needle cage (29) into the planet gear 1 (6).
  - ④ Assemble thrust washer (12), planet gear 1 (6), and then stop ring (24) to the pin 1 (11).
- ※ Take care not to mistake the matching marks of each part.

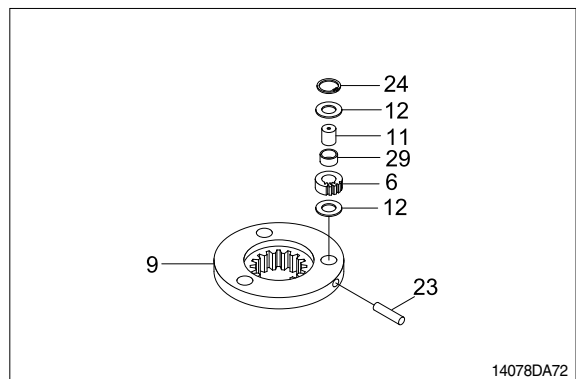

(10) Assemble carrier 1 (9) assembly into the ringgear.

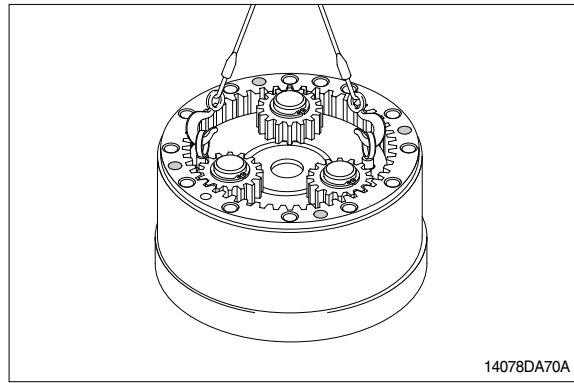

(11) Hammer 4 knock pins (16) around the ring gear (3).

(12) Assemble sun gear 1 (7) and stop ring (24) to the drive shaft of the swing reduction gear.

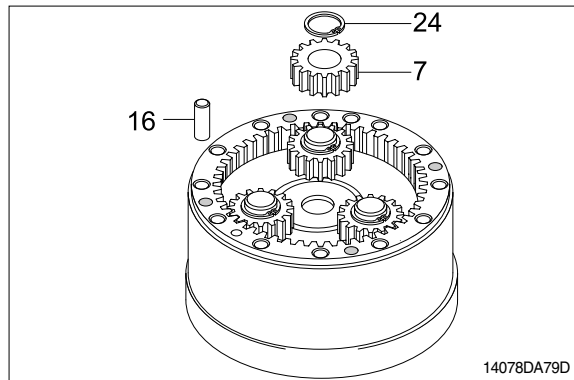

(13) Apply loctite to the tapped holes of the ring gear (3) and then mount swing motor onto the ring gear (3).

※ Don't fail to coincide the gauge bar (14) hole.

(14) Tighten socket bolts (19) around the swing motor assembly.  
· Tightening torque : 13.5kgf · m (98lbf · ft)

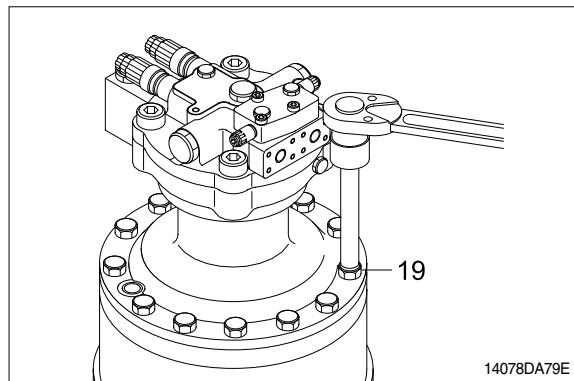

(15) Assemble plugs (21, 22), gauge bar (14) and gauge pipe (15).

