

## GROUP 5 SWING DEVICE

### 1. REMOVAL AND INSTALL OF MOTOR

#### 1) REMOVAL

- (1) Lower the work equipment to the ground and stop the engine.
- (2) Operate the control levers and pedals several times to release the remaining pressure in the hydraulic piping.
- (3) Loosen the breather slowly to release the pressure inside the hydraulic tank.

**▲ Escaping fluid under pressure can penetrate the skin causing serious injury.**

※ When pipes and hoses are disconnected, the oil inside the piping will flow out, so catch it in oil pan.

- (4) Disconnect hose assembly(2).
- (5) Disconnect pilot line hoses(3,4,5,6,7,8).
- (6) Sling the swing motor assembly(1) and remove the swing motor mounting bolts (9).

※ Motor device weight : 32kg(70.5lb)

- (7) Remove the swing motor assembly.

※ When removing the swing motor assembly, check that all the piping have been disconnected.

#### 2) INSTALL

- (1) Carry out installation in the reverse order to removal.
- (2) Bleed the air from the swing motor.
  - ① Remove the air vent plug.
  - ② Pour in hydraulic oil until it overflows from the port.
  - ③ Tighten plug lightly.
  - ④ Start the engine, run at low idling and check oil come out from plug.
  - ⑤ Tighten plug fully.
- (3) Confirm the hydraulic oil level and check the hydraulic oil leak or not.

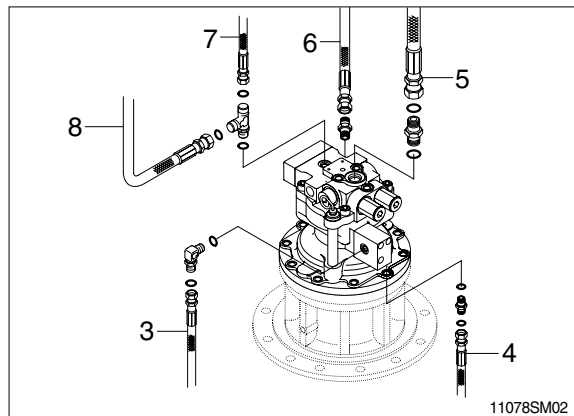
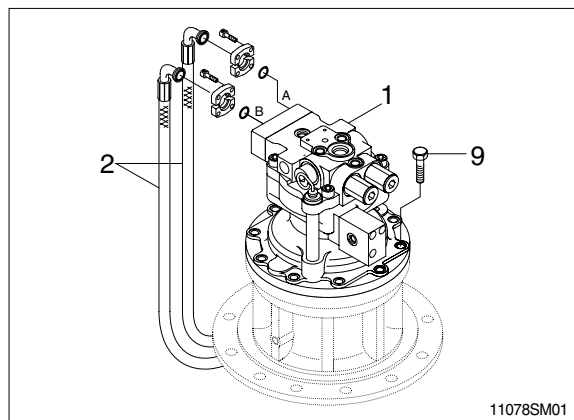

## 2. DISASSEMBLY AND ASSEMBLY OF SWING MOTOR

### 1) STRUCTURE

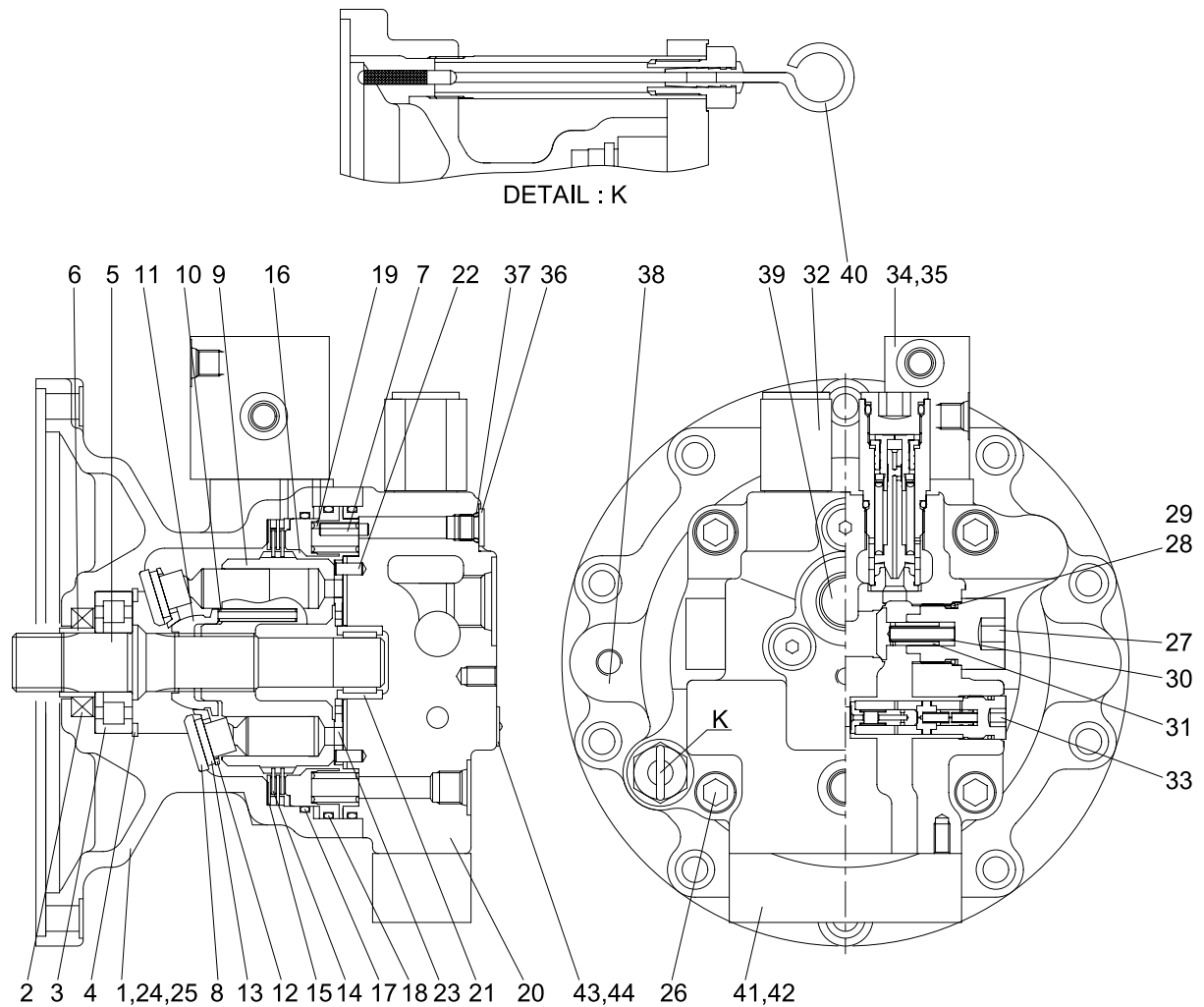

11072SM02

1	Body	16	Brake piston	31	Check
2	Oil seal	17	O-ring	32	Relief valve assembly
3	Roll bearing	18	O-ring	33	Reactionless valve assembly
4	Snap ring	19	Spring	34	Time delay valve assembly
5	Shaft	20	Rear cover	35	Wrench bolt
6	Bushing	21	Needle bearing	36	Plug
7	Pin	22	Pin	37	O-ring
8	Shoe plate	23	Valve plate	38	Plug
9	Cylinder block	24	O-ring	39	Plug
10	Spring	25	O-ring	40	Level gauge
11	Ball guide	26	Wrench bolt	41	Flange
12	Set plate	27	Plug	42	O-ring
13	Piston assembly	28	Back up ring	43	Name plate
14	Friction plate	29	O-ring	44	Rivet
15	Plate	30	Spring		

## 2) DISASSEMBLY

- (1) Lift the motor out. Clean the motor in kerosene and dry with compressed air.
  - ※ To avoid dust inside the motor, mask all the ports of the motor with tapes.

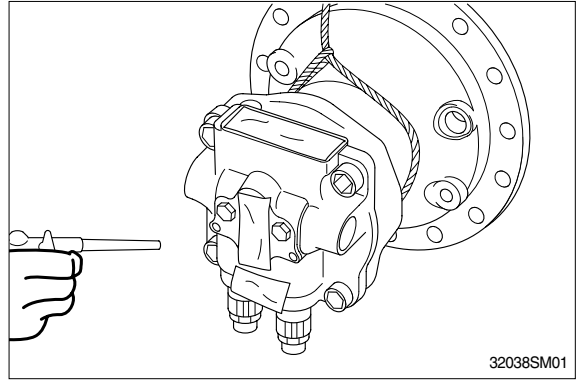

- (2) Loosen the drain plug to discharge oil in the body(1).

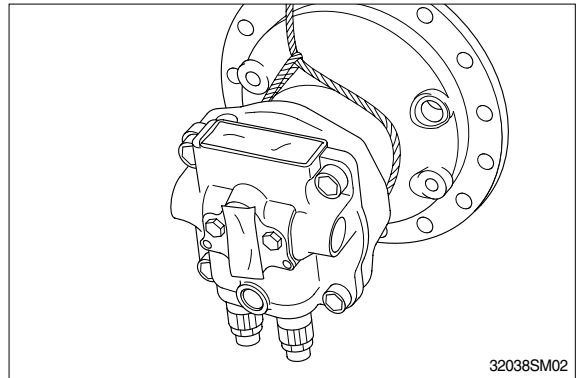

- (3) Fix the drive shaft(5) on the workbench with the end of output shaft down. Put matching marks on body (1) and valve rear cover(20) for easy reassembly.

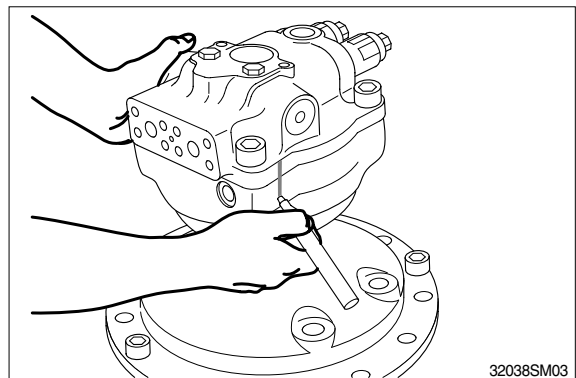

- (4) Remove the valve(34).

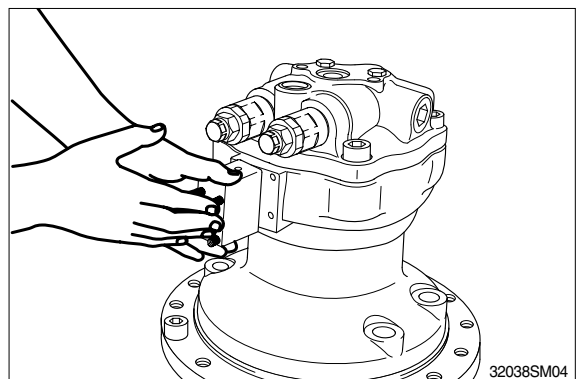

- (5) Remove the relief valve(32) from rear cover(20).

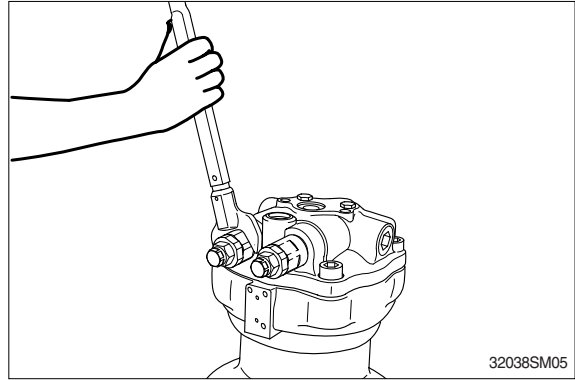

- (6) Remove plug(27) from rear cover(20) and spring(30), check(31).  
※ Be careful not to damage the check seat assembly.

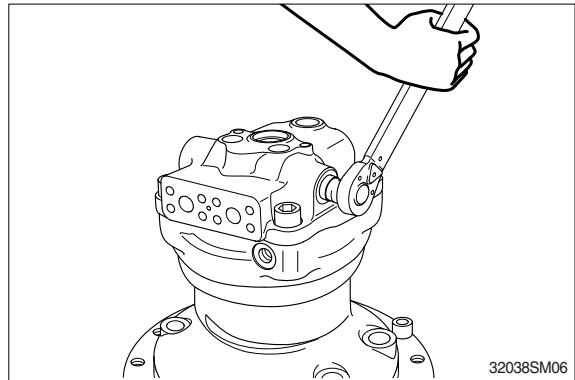

- (7) Remove rear cover(20) from body(1).  
Then, remove the valve plate(23) from rear cover(20) with care.

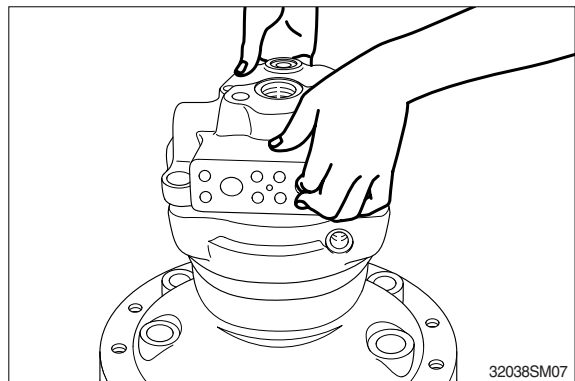

- (8) Remove the brake spring(19) from brake piston(16).

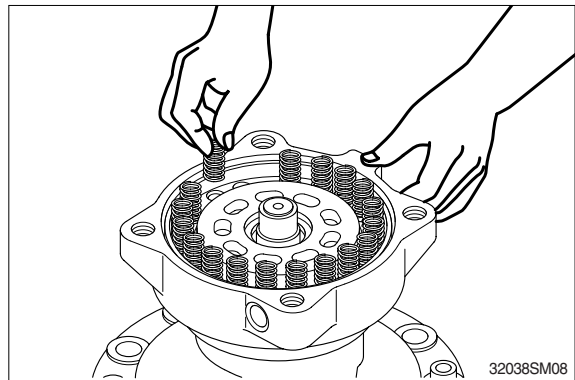

(9) Remove brake piston(16) from body(1).

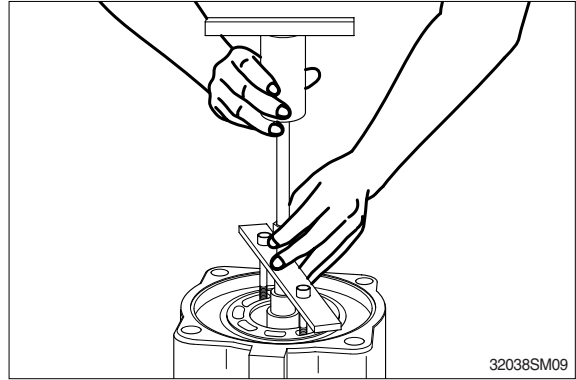

(10) Remove the cylinder(9) from the output shaft(5) with the motor positioned horizontally. Remove ball guide(11), set plate(12), piston(13) and shoe plate(8).

※

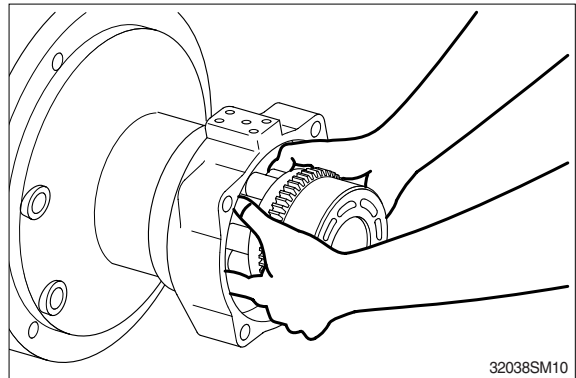

(11) Remove friction plate(14) and separate plate(15) from body(1).

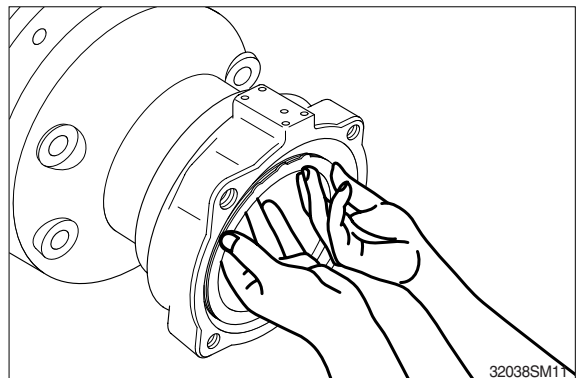

(12) Remove snap ring(4) and remove drive shaft(5) from body(1).

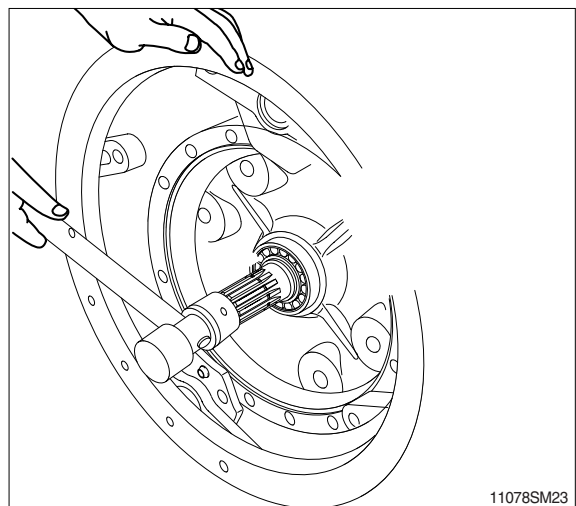

(13) Remove the cone of roller bearing(3) by press.

※ Do not reuse bearings.

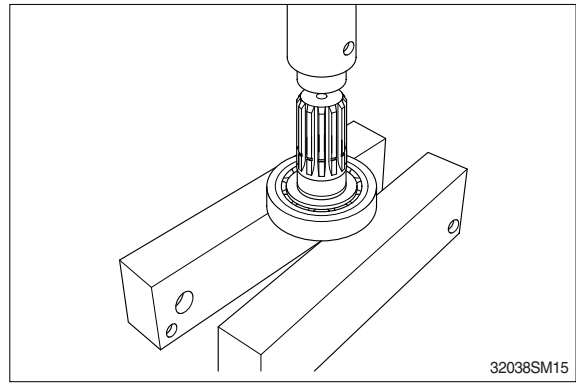
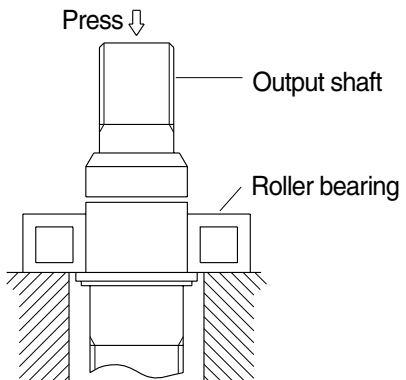

(14) Remove bushing(6) and oil seal(2) from body(1).

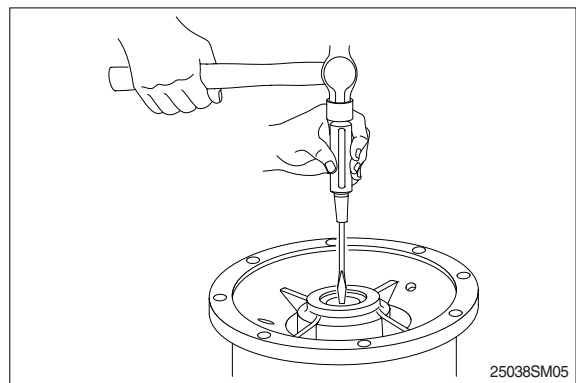

(15) Remove the needle bearing(21) from the rear cover(20) by using slide hammer bearing puller.

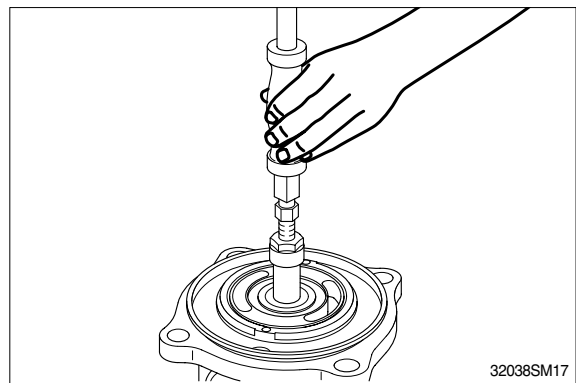

(16) When disassembling the relief valve, release the plug(3).

Remove the piston(7), spring seat(9), spring(8) and plunger(6) with the body(1) downwards.

※ Do not release the lock nut(15).

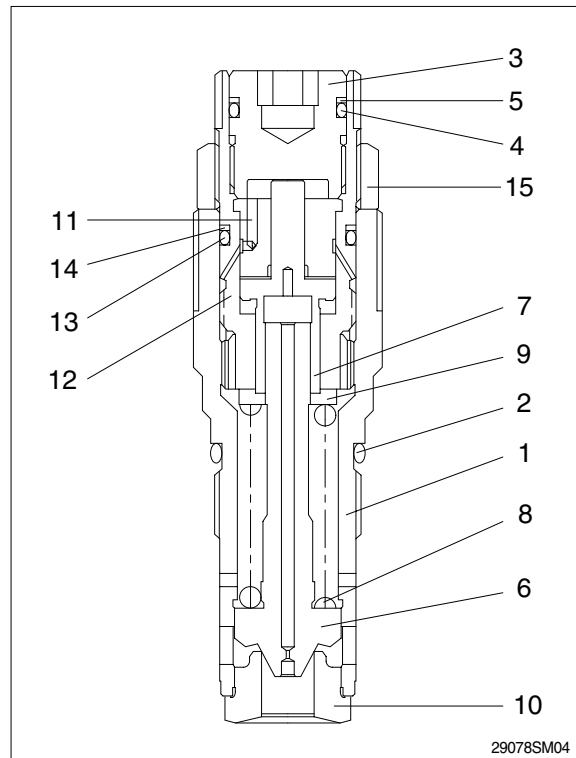

This completes disassembly.

### 3) ASSEMBLY

Do the reassembly in the reverse procedure of the disassembly.

- (1) Apply three bond of white color on outer surface of oil seal(2) and insert it to the body(1).

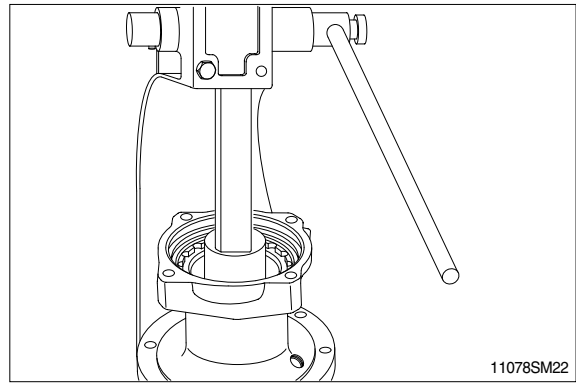

- (2) Install the roller bearing(3) to the drive shaft(5).

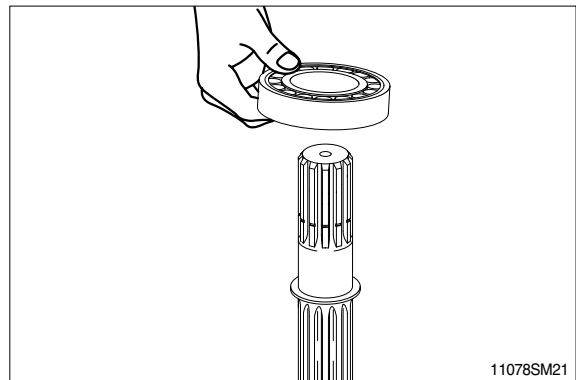

- (3) Insert the drive shaft(5) into the body(1) with the plastic hammer lightly.

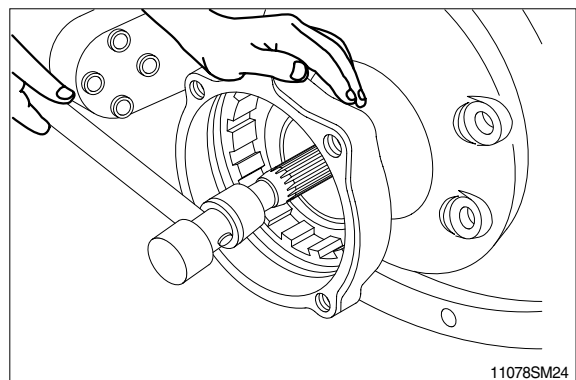

- (4) Install the snap ring(4) to the body(1).

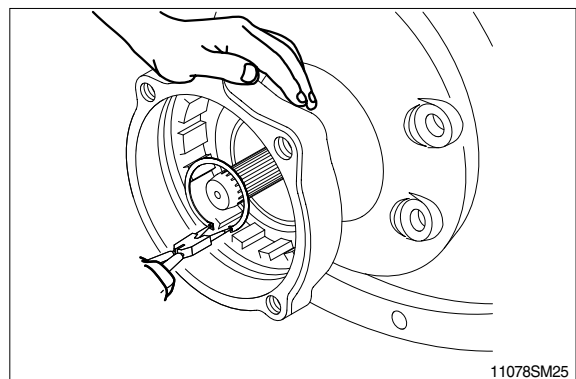



- (5) Insert the shoe plate(8) with the body(1) position horizontally.

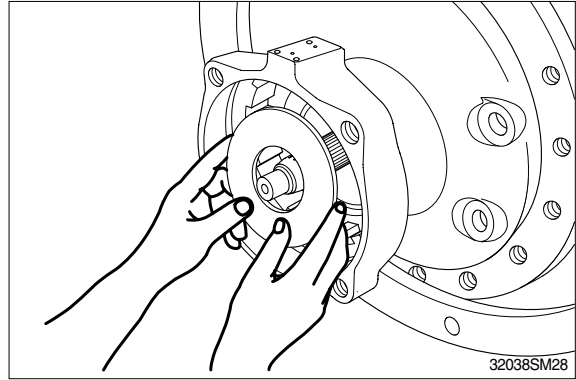

- (6) Insert the ball guide(11) into the cylinder (9).

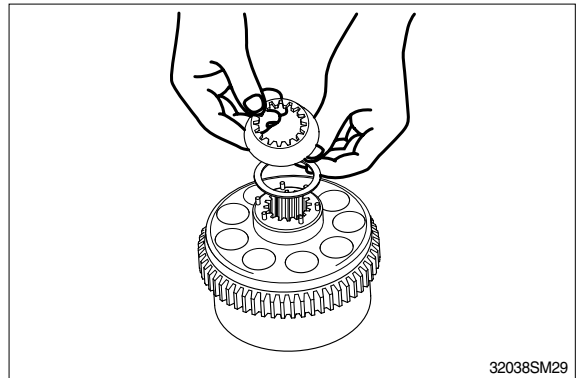

- (7) Install the piston sub-assembly(13) to the set plate(12).



- (8) Reassemble the piston assembly(9) to the body(1).

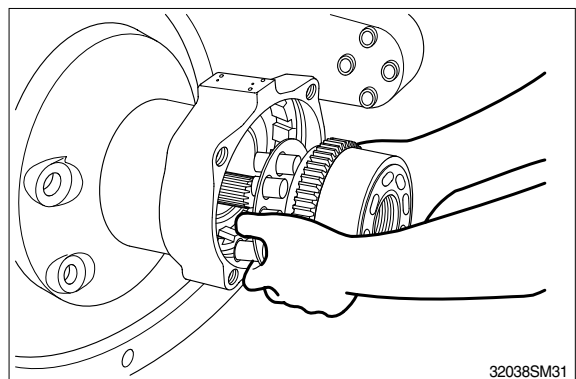

(9) Assembly friction plate(14) and plate(15) to the body(1).

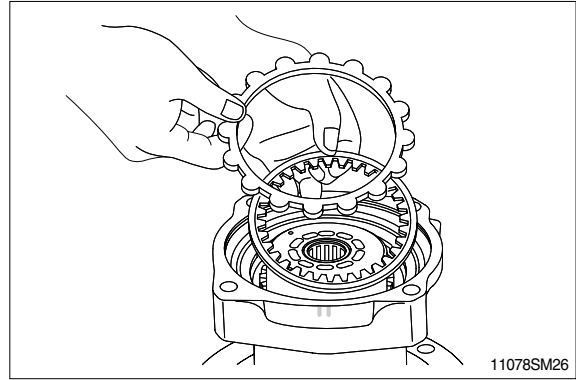

(10) Insert O-ring(17) inside the body(1).

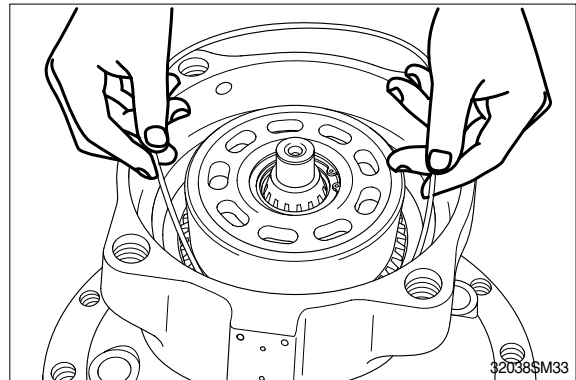

(11) Reassemble brake piston(16) to the body (1).

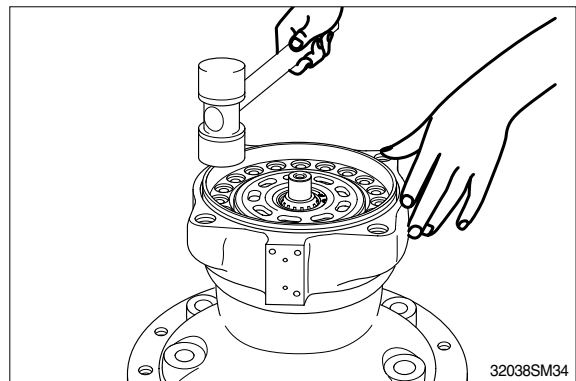

(12) Reassemble brake spring(19) to the brake piston(16).

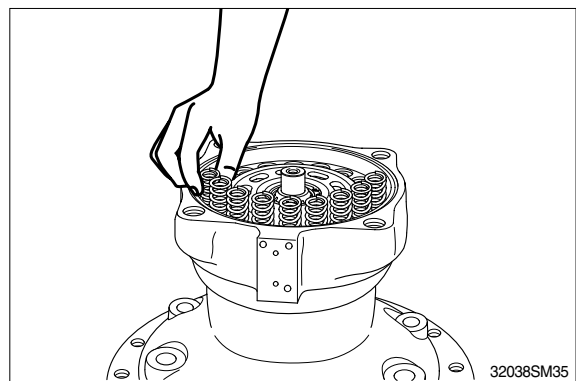

(13) When assembling the needle bearing(21), insert the needle bearing(21) into rear cover(20) by hammering.

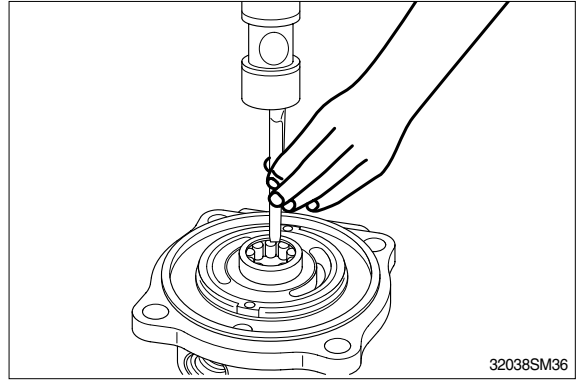

(14) Reassemble valve plate(23) to the rear cover(20) and reassemble O-ring(18).

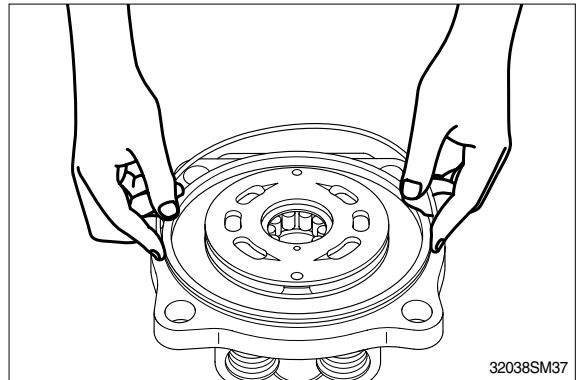

(15) Connect the rear cover(20) with the body (1) and tighten the wrench bolt(26).

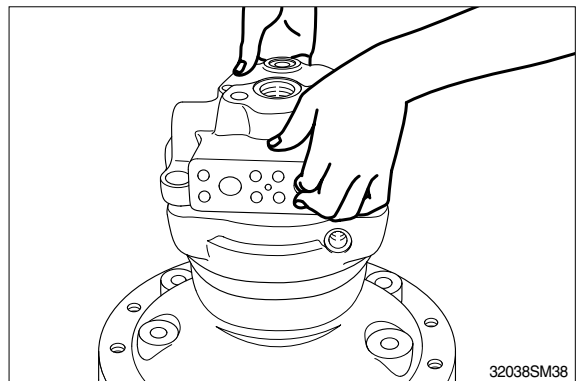

(16) Insert check(31) and spring(30) in the valve casing and install O-ring(29) and back up ring(28). Tighten plug(27) to the rear cover(20).

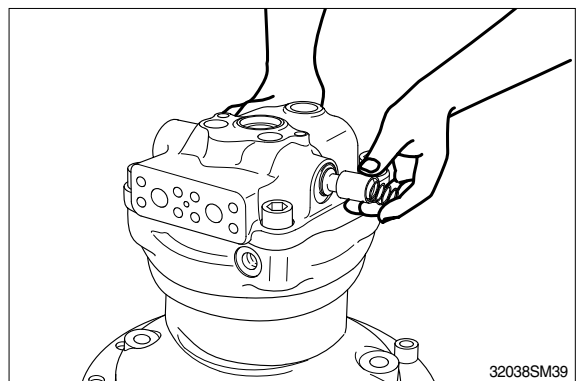

(17) Insert O-rings to the relief valve (32) and reassemble them to rear cover(20).

This completes assembly.

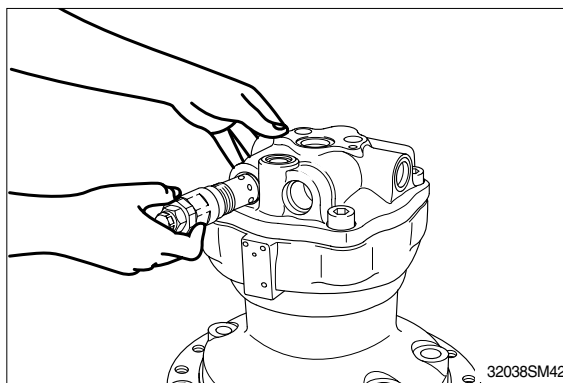

### 3. REMOVAL AND INSTALL OF REDUCTION GEAR

#### 1) REMOVAL

- (1) Remove the swing motor assembly.  
For details, see **removal of swing motor assembly**.
- (2) Sling reduction gear assembly(1) and remove mounting bolts(2).
- (3) Remove the reduction gear assembly.
  - Reduction gear device weight : 95kg  
(209lb)



#### 2) INSTALL

- (1) Carry out installation in the reverse order to removal.
  - Tightening torque :  $29.7 \pm 4.5 \text{kgf} \cdot \text{m}$   
( $215 \pm 32.5 \text{lb} \cdot \text{ft}$ )

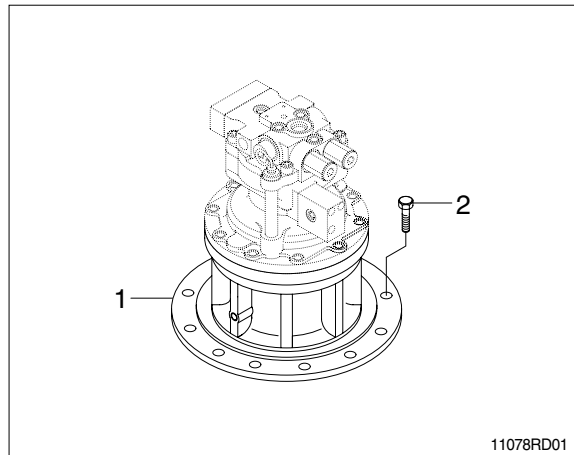

## 4. DISASSEMBLY AND ASSEMBLY OF REDUCTION GEAR

### 1) STRUCTURE

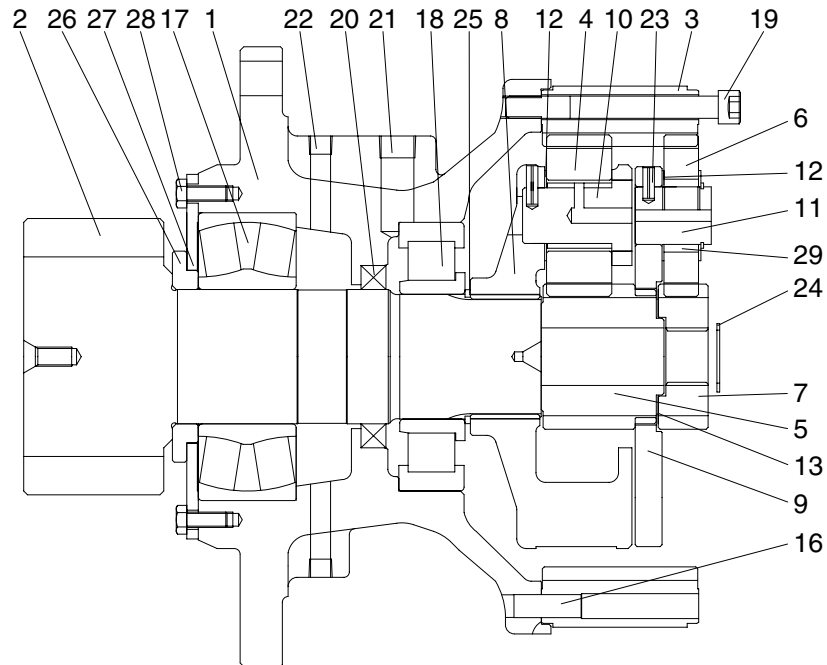

11072SM03

1	Casing	10	Pin No.2 assembly	21	Plug(B)
2	Drive shaft	11	Pin No.1	22	Plug(A)
3	Ring gear	12	Thrust washer(B)	23	Spring pin
4	Planet gear No.2	13	Thrust washer(A)	24	Stop ring
5	Sun gear No.2	16	Knock pin	25	Stop ring
6	Planet gear No.1	17	Sph roller bearing	26	Spacer
7	Sun gear No.1	18	Cyl roller bearing	27	Cover plate
8	Carrier No.2	19	Bolt	28	Bolt
9	Carrier No.1	20	Oil seal	29	Needle cage

## 2) DISASSEMBLY

- (1) Remove gauge bar(14) and gauge pipe (15) from the swing motor casing.
  - ※ Pour the gear oil out of reduction gear into the clean bowl to check out the friction decrease.

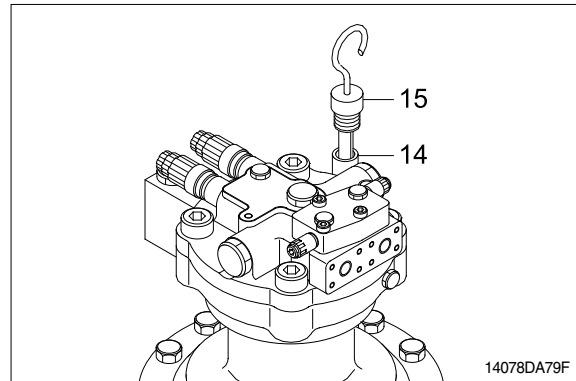

- (2) Loosen the socket bolts(19) to separate swing motor from reduction gear.

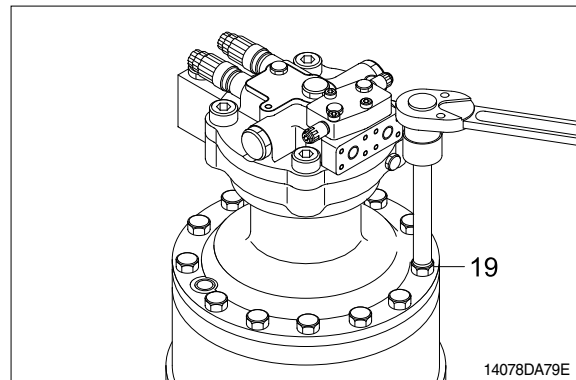

- (3) Remove stop ring(24) and then sun gear(7).

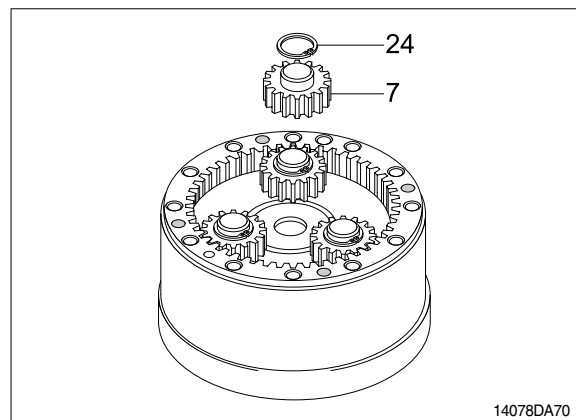

- (4) Tighten two M10 eye bolts to carrier(9) and lift up and remove carrier(9) as subassembly.

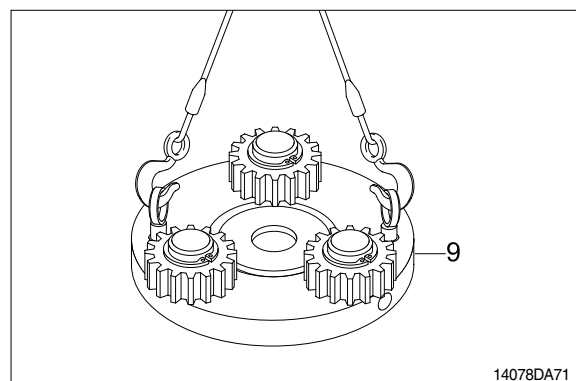

(5) Disassembling carrier1(9) assembly.

- ① Remove stop ring(24).
  - ② Remove thrust washer(12), planet gear1 (6), needle cage(29), and thrust washer(12) from the carrier.
  - ③ Using M8 solid drill, crush spring pin(23) so that the pin1(11) can be removed by hammering.
- ※ Do not reuse spring pin(23).
  - ※ Do not remove pin1(11), carrier1(9) and spring pin(23) but in case of replacement.
  - ※ Put matching marks on the planet gear1 (6) and the pin1(11) for easy reassembly.

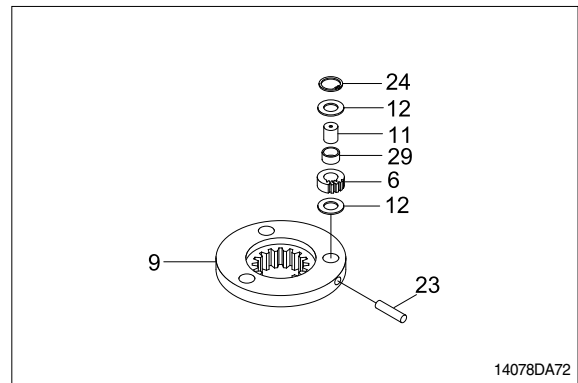

(6) Remove sun gear2(5) and thrust washer (13).

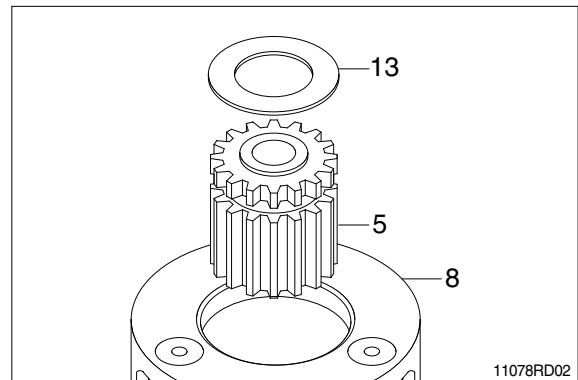

(7) Remove carrier2(8) assembly from casing (1).

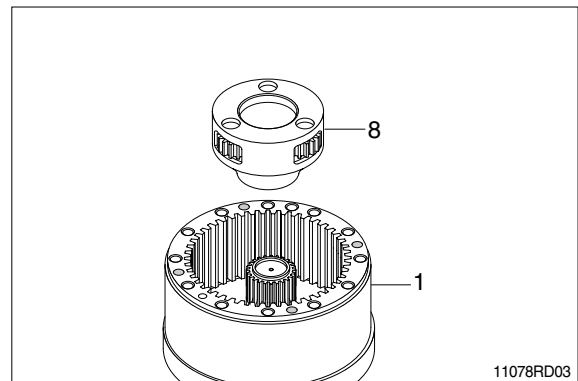



(8) Disassembling carrier2(8) assembly

- ① Using M8 solid drill, crush spring pin(23) so that the pin2(10) can be removed.
  - ※ Do not reuse spring pin(23).
- ② Remove pin2(10), planet gear2(4) and thrust washer(12) from the carrier2(8).
  - ※ Put matching marks on the planet gear2 (4) and the pin2(23) for easy reassembly.
  - ※ Do not disassemble pin2(23), carrier2(8) and spring pin(23) but in case of replacement.

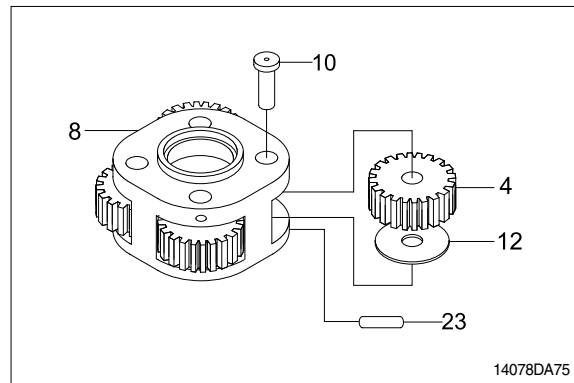

(9) Tighten two M16 eyebolt to the ring gear(3) and then lift the ring gear(3) out of casing(1).

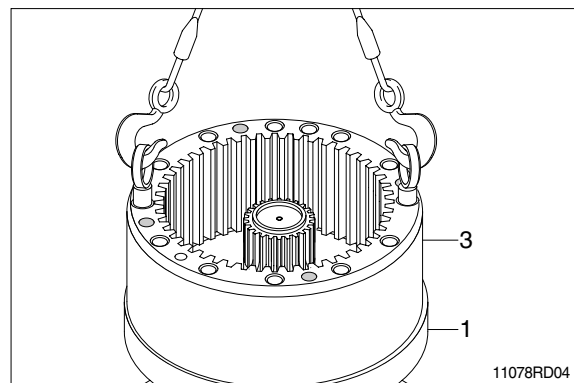

(10) Remove stop ring (25) from the drive shaft(2).

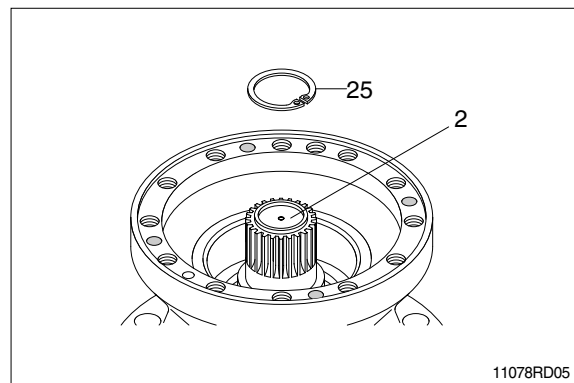

(11) Remove the bolt(28) and remove the drive shaft(2) with roller bearing(17), the spacer(26) and the cover plate(27).

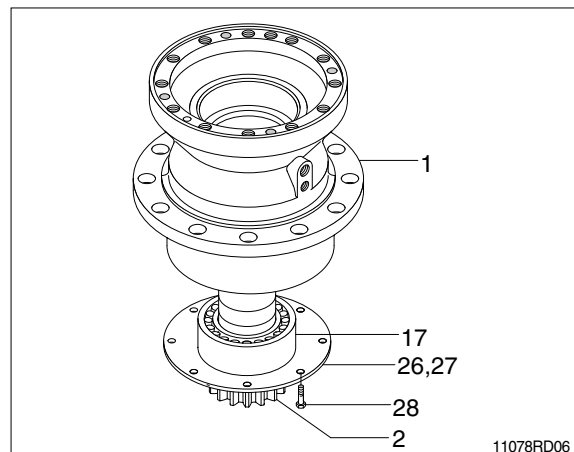

(12) Remove the roller bearing(17), the cover plate(27) and the spacer(26) from the drive shaft(2).

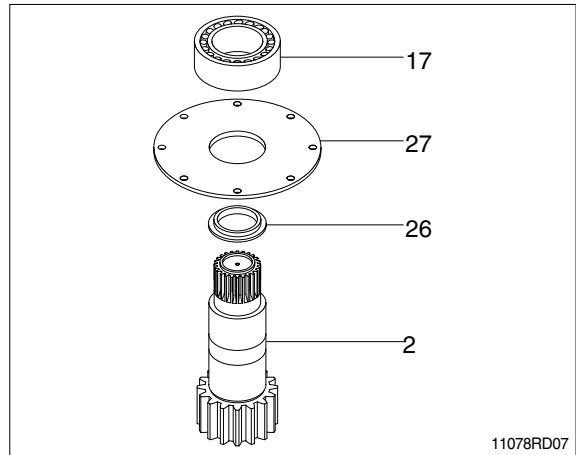

(13) Using the bearing disassembly tool, remove roller bearing(18).

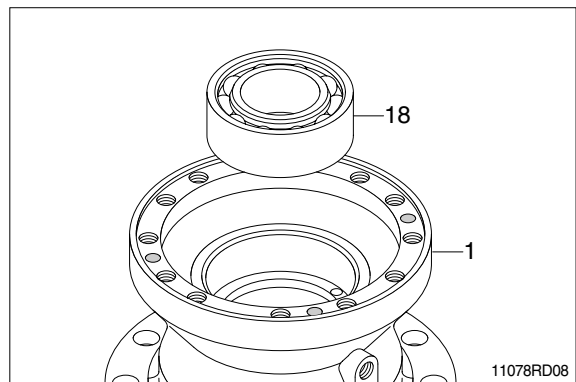

(14) Remove the oil seal(20).

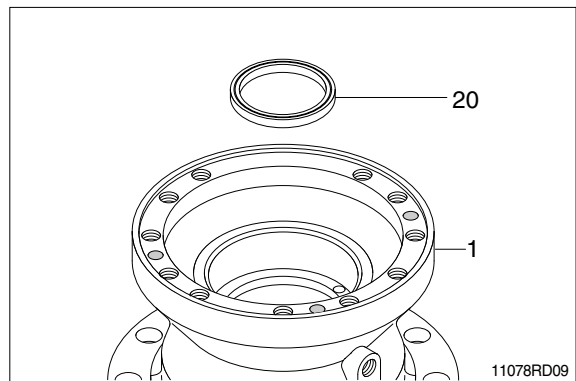

(15) Remove plugs(21, 22) from the casing(1).

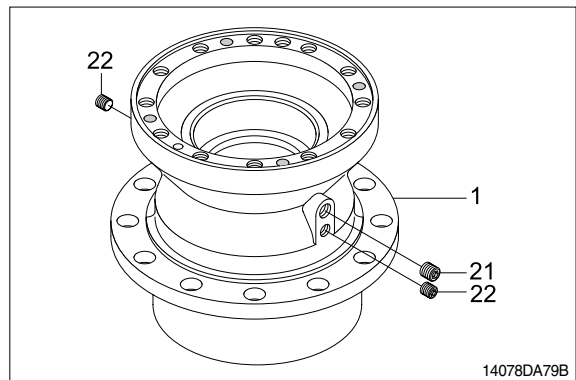

### 3) ASSEMBLY

- (1) Assemble the spacer(26), the cover plate(27) and the roller bearing(17) on the drive shaft(2).

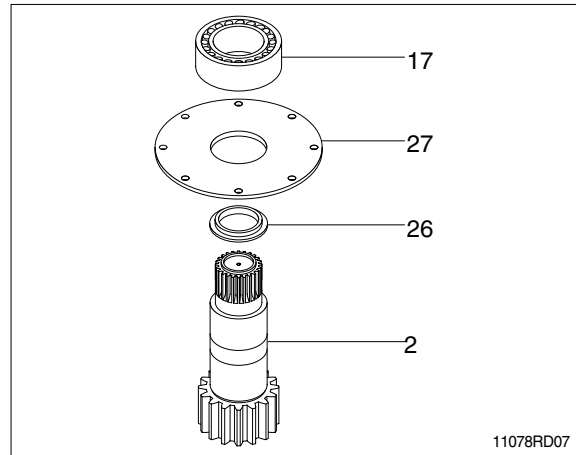

- (2) Assemble the drive shaft sub assembly(2) into the casing(1) and tighten the bolt(28) with loctite No.262.

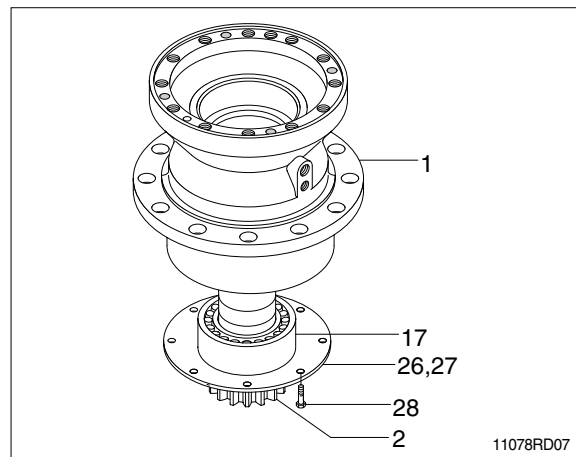

- (3) Install the oil seal(20) and the roller bearing(18).

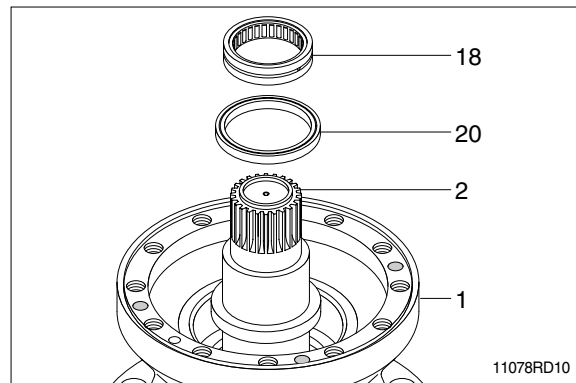

- (4) Install stop ring(25) on the drive shaft (2).

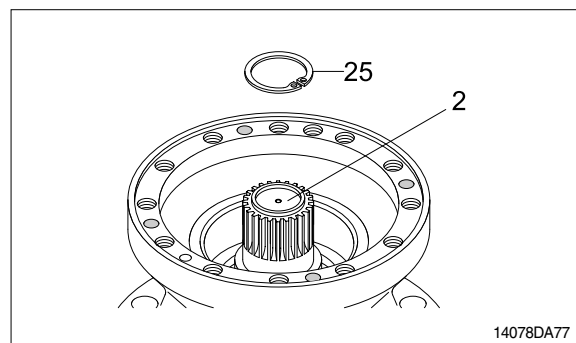

(5) Apply loctite to the tapped holes of casing (1).

(6) Tighten 2 M16 eye bolts to the ring gear(3) and lift up and then assemble it onto the casing(1).

※ Don't fail to coincide the knock pin(16) holes.

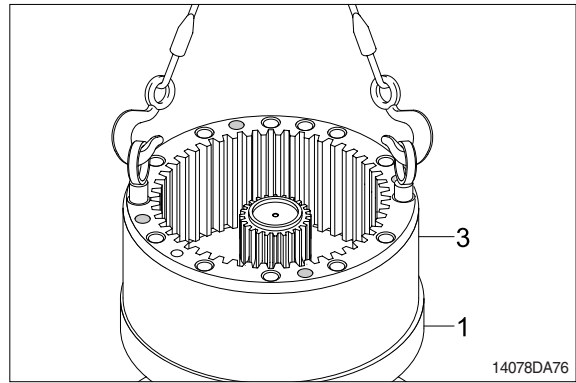

(7) Assembling carrier2(8) assembly.

① Install thrust washer(12) and the planet gear2(4) inside the carrier2(8).

② Assemble the pin2(10) to the carrier2(8) and then press the spring pin(23) by hammering.

③ Punch 2 points of the spring pin(23) lip.

※ Take care not to mistake the matching marks of each part.

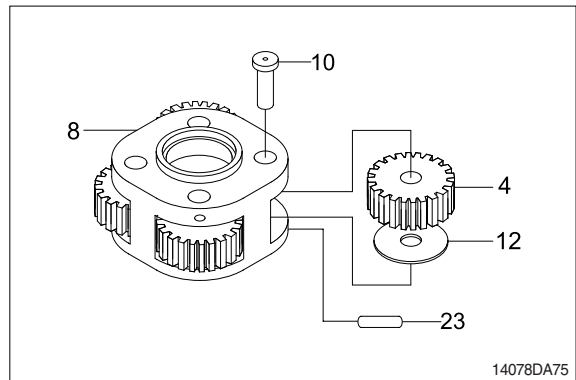

(8) Assemble carrier2(8) assembly correctly to the drive shaft(2).

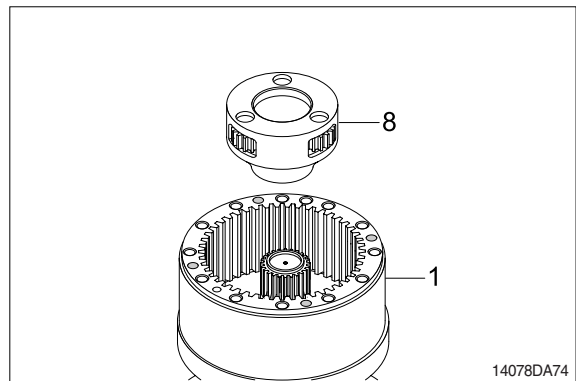

(9) Assemble sun gear2(5) and thrust gear (13) to the center of the carrier2(8) assembly.

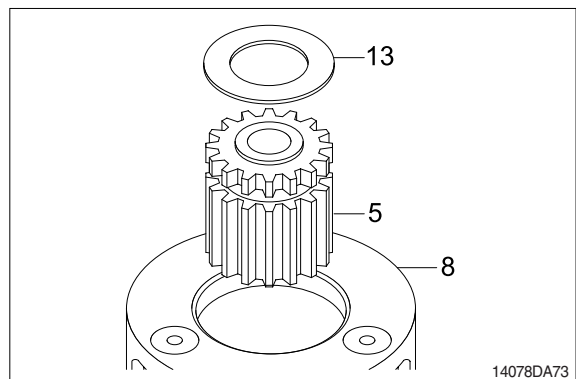

(10) Assembling carrier(9) assembly.

- ① Assemble the pin(11) to the carrier(9) and then press the spring pin(23) by hammering.
  - ② Punch 2 points of the spring pin's(23) lip.
  - ③ Install needle cage(29) into the planet gear(6).
  - ④ Assemble thrust washer(12), planet gear(6), and then stop ring(24) to the pin(11).
- ※ Take care not to mistake the matching marks of each part.

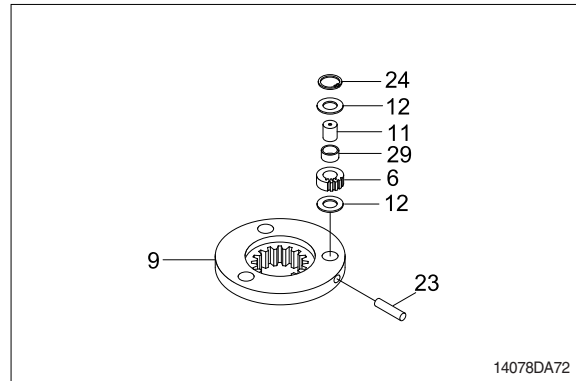

(11) Assemble carrier(9) assembly into the ring gear.

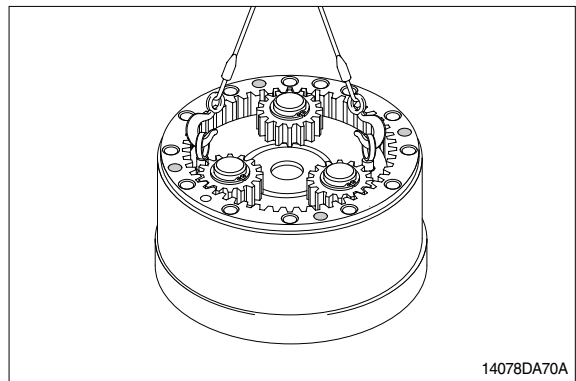

(12) Hammer 4 knock pins(16) around the ring gear(3).

(13) Assemble sun gear(7) and stop ring(24) to the drive shaft of the swing reduction gear.

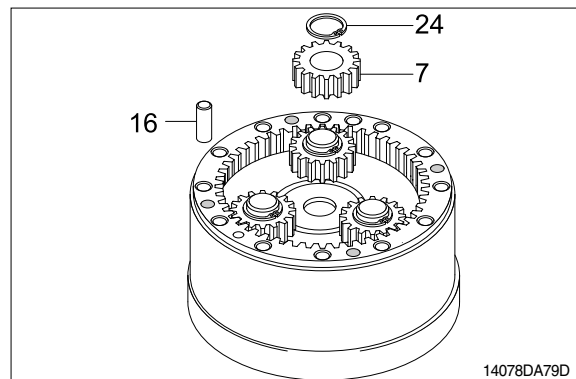

(14) Apply loctite to the tapped holes of the ring gear(3) and then mount swing motor onto the ring gear(3).

※ Don't fail to coincide the gauge bar(14) hole.

(15) Tighten socket bolts(19) around the swing motor assembly.

· Tightening torque : 24kgf · m(173lbf · ft)

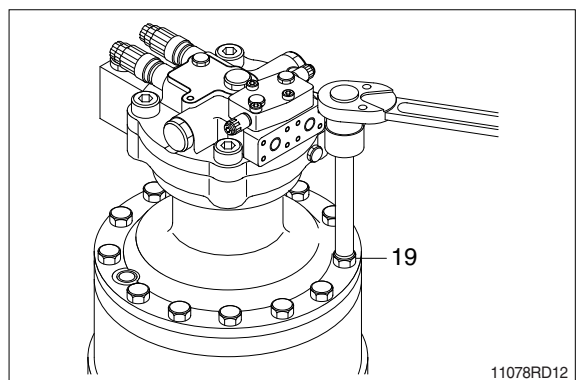

(16) Assemble plugs(21, 22), gauge bar(14) and gauge pipe(15).

