

GROUP 4 HYDRAULIC SYSTEM

1. HYDRAULIC COMPONENTS MOUNTING 1

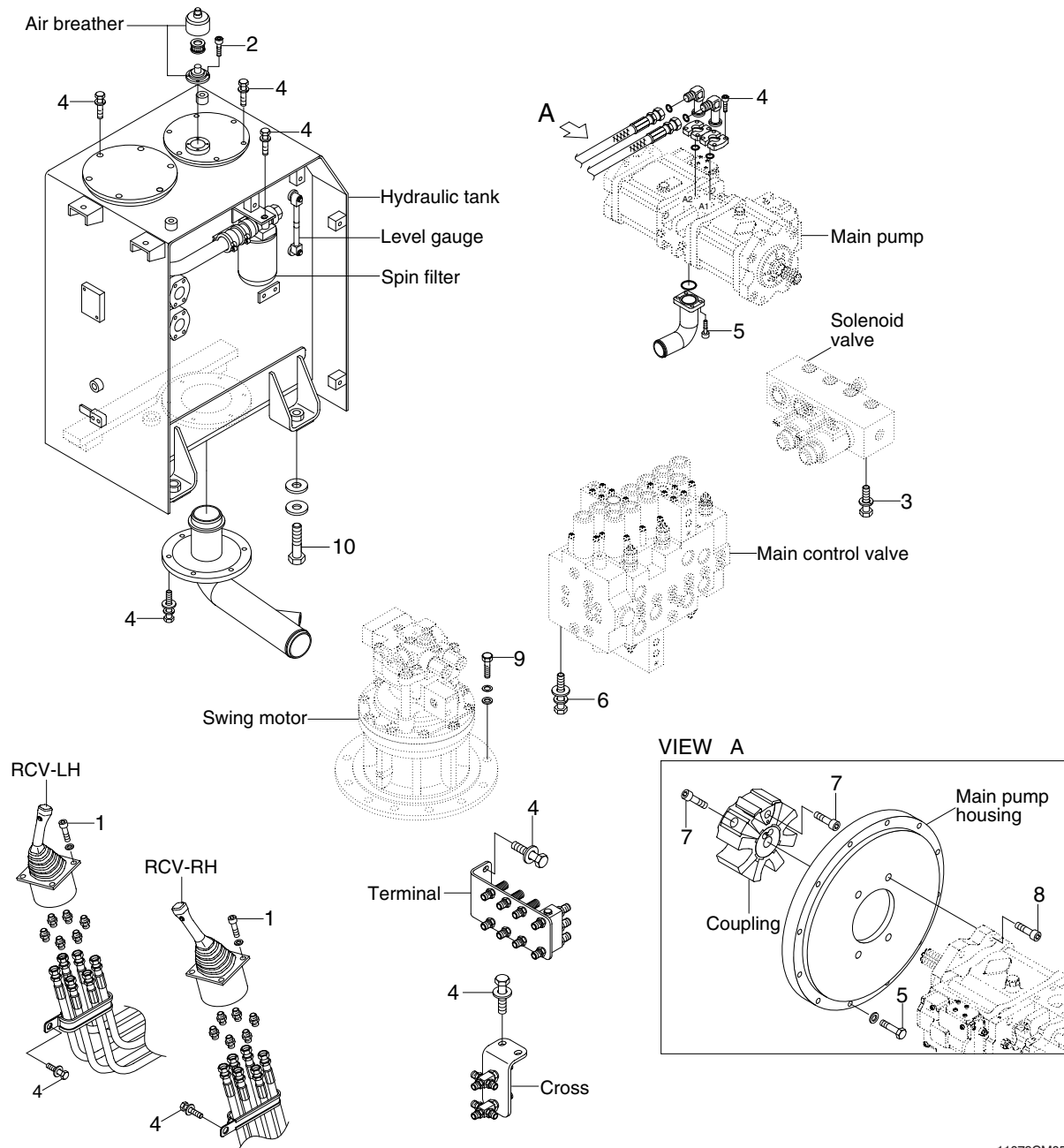

11079CM05

• Tightening torque

Item	Size	kgf · m	lbf · ft
1	M 6 × 1.0	1.05 ± 0.2	7.6 ± 1.45
2	M 6 × 1.0	1.44 ± 0.3	10.4 ± 2.2
3	M 8 × 1.25	2.5 ± 0.5	18.1 ± 3.6
4	M 10 × 1.5	6.9 ± 1.4	49.9 ± 10.1
5	M 10 × 1.5	6.1 ± 0.3	44.1 ± 2.2

Item	Size	kgf · m	lbf · ft
6	M 12 × 1.75	12.2 ± 1.3	88.2 ± 9.4
7	M 16 × 2.0	22.0 ± 1.0	159 ± 7.2
8	M 16 × 2.0	22.1 ± 2.4	160 ± 17.4
9	M 16 × 2.0	29.6 ± 3.2	214 ± 23.1
10	M 20 × 2.5	45 ± 5.1	325 ± 36.9

2. HYDRAULIC COMPONENTS MOUNTING 2

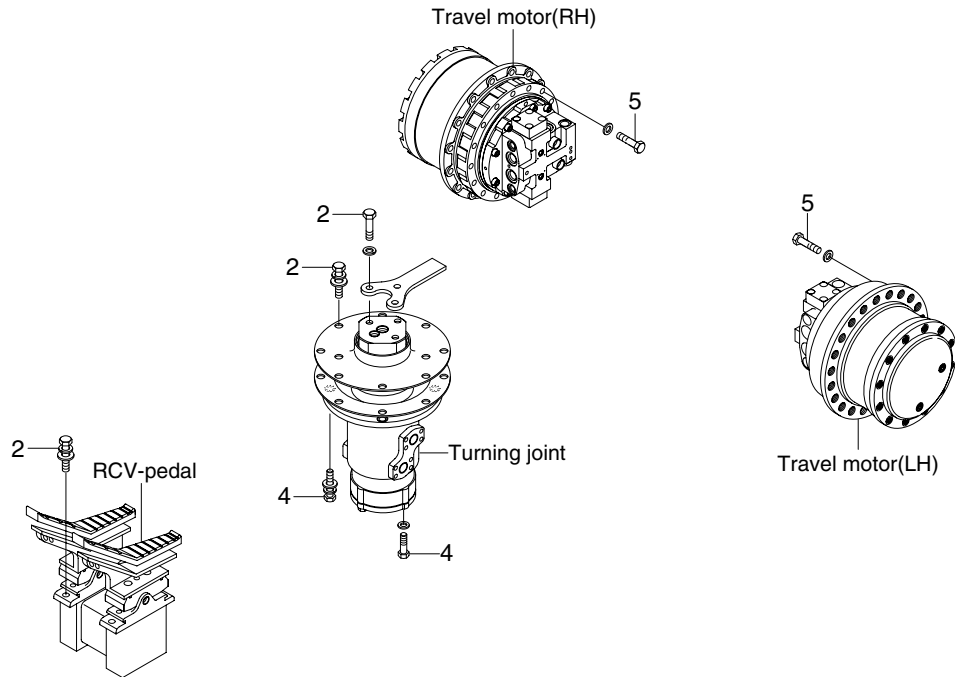

Boom safety lock system

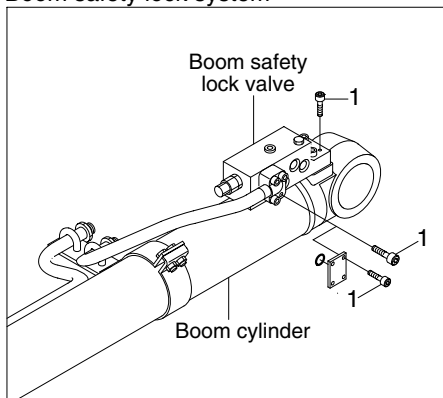

Arm safety lock system

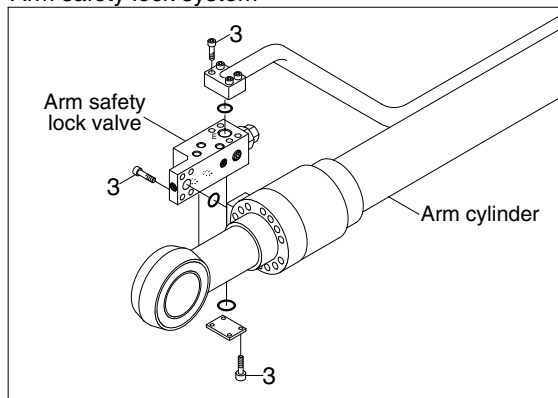

11079CM06

· Tightening torque

Item	Size	kgf · m	lbf · ft
1	M 8 × 1.25	4.05 ± 0.8	29.3 ± 5.8
2	M10 × 1.5	6.9 ± 1.4	49.9 ± 10.1
3	M10 × 1.5	8.27 ± 1.7	59.8 ± 12.3

Item	Size	kgf · m	lbf · ft
4	M12 × 1.75	12.8 ± 3.0	92.6 ± 21.7
5	M16 × 2.0	23 ± 2.5	166.3 ± 18.1
-	-	-	-

3. HYDRAULIC COMPONENTS MOUNTING 3

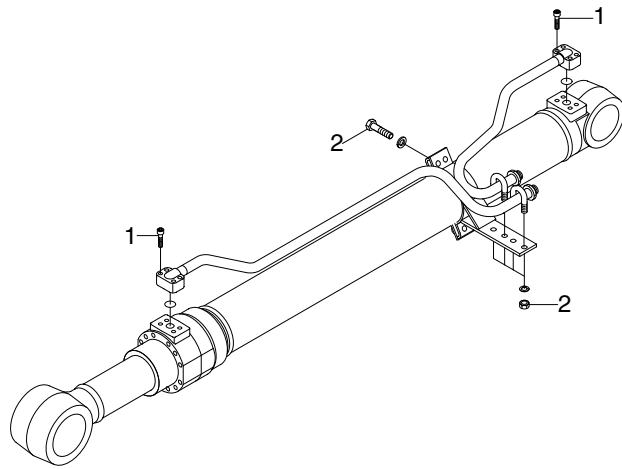

BOOM CYLINDER

Solenoid valve

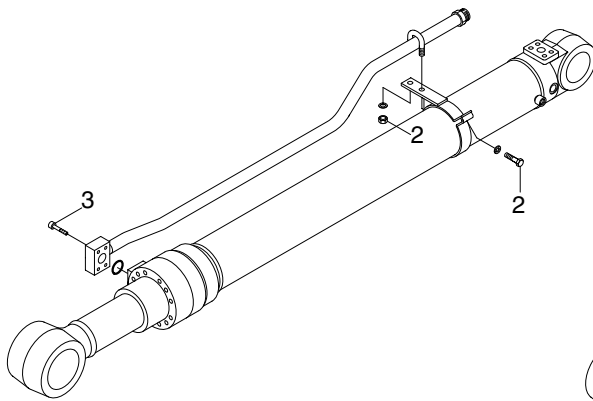
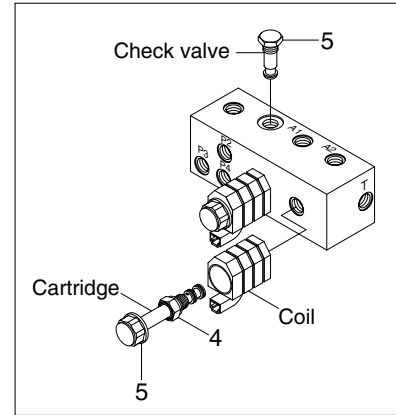

ARM CYLINDER

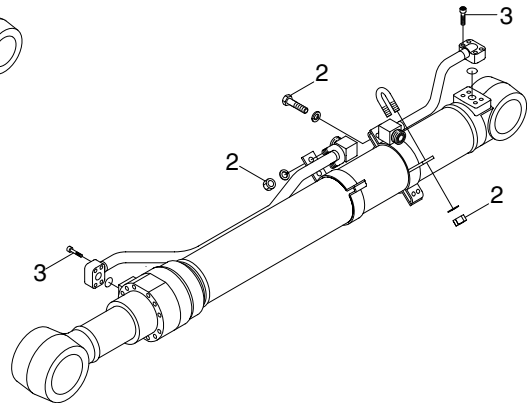

BUCKET CYLINDER

11079CM07

· Tightening torque

Item	Size	kgf · m	lbf · ft
1	M 8×1.25	2.7±0.3	19.5±2.2
2	M10×1.5	3.2±0.3	23.1±2.2
3	M10×1.5	5.4±0.5	39.1±3.6
4	-	0.4	2.9

Item	Size	kgf · m	lbf · ft
5	-	2.0	14.5