

GROUP 9 ENGINE CONTROL SYSTEM

1. CPU CONTROLLER MOUNTING

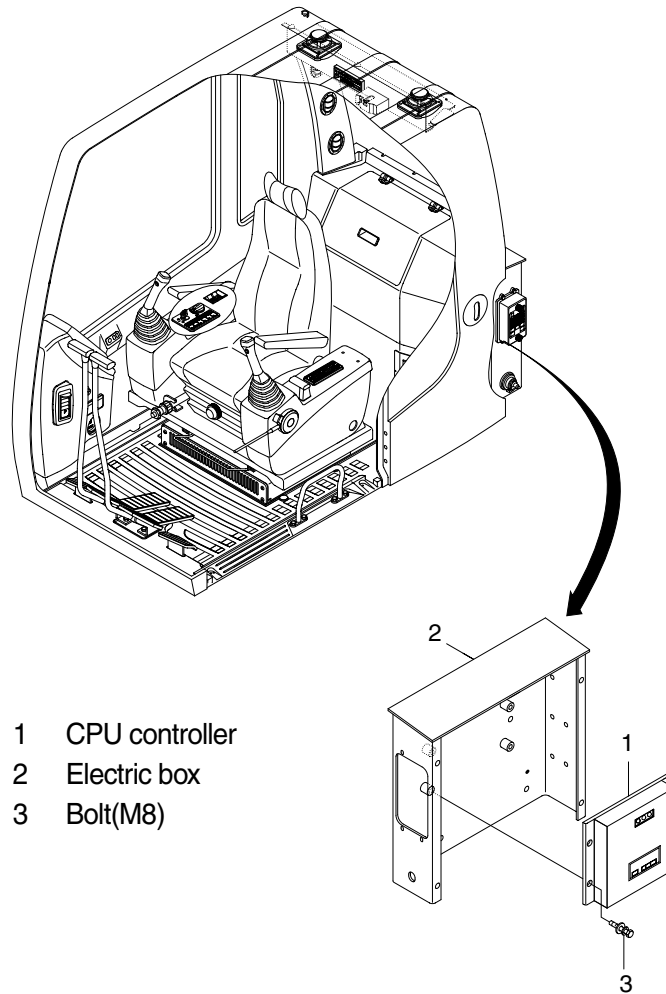

- 1 CPU controller
- 2 Electric box
- 3 Bolt(M8)

11075MS12

2. CPU CONTROLLER ASSEMBLY

- 1) Remove four pieces of bolt(3) of electric box(2).
- 2) Disconnect 2 connectors from CPU controller.
- 3) Remove 6 pieces of screw and open the cover of CPU controller.
- 4) Inspection : Check PCB(Printed Circuit Board)
 - (1) If any damage is found, replace CPU controller assembly.
 - (2) If not, but CAPO system does not work please report it to HHI dealer or A/S department.

3. EXCHANGE METHOD OF THE ROM

- 1) Disassemble the ash tray(2).
- 2) Disassemble the wiper motor cover(3).
- 3) Disassemble the cluster(1).

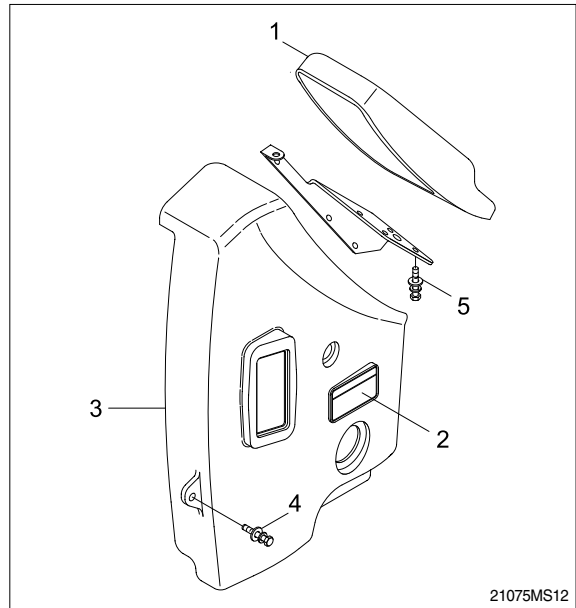

- 4) Loosen the screws(6EA) located back of the cluster.
- 5) Then you can open the upper case of the cluster easily.

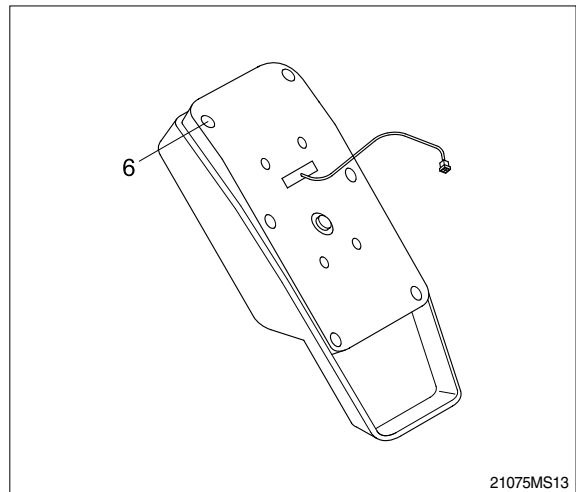

- 6) Install the new ROM.(Be careful of direction and assmelbe the cluster in the reverse order to removal).

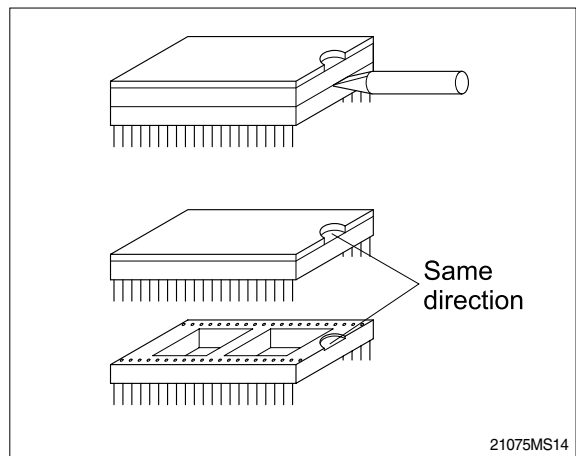

4. ENGINE ACCEL ACTUATOR

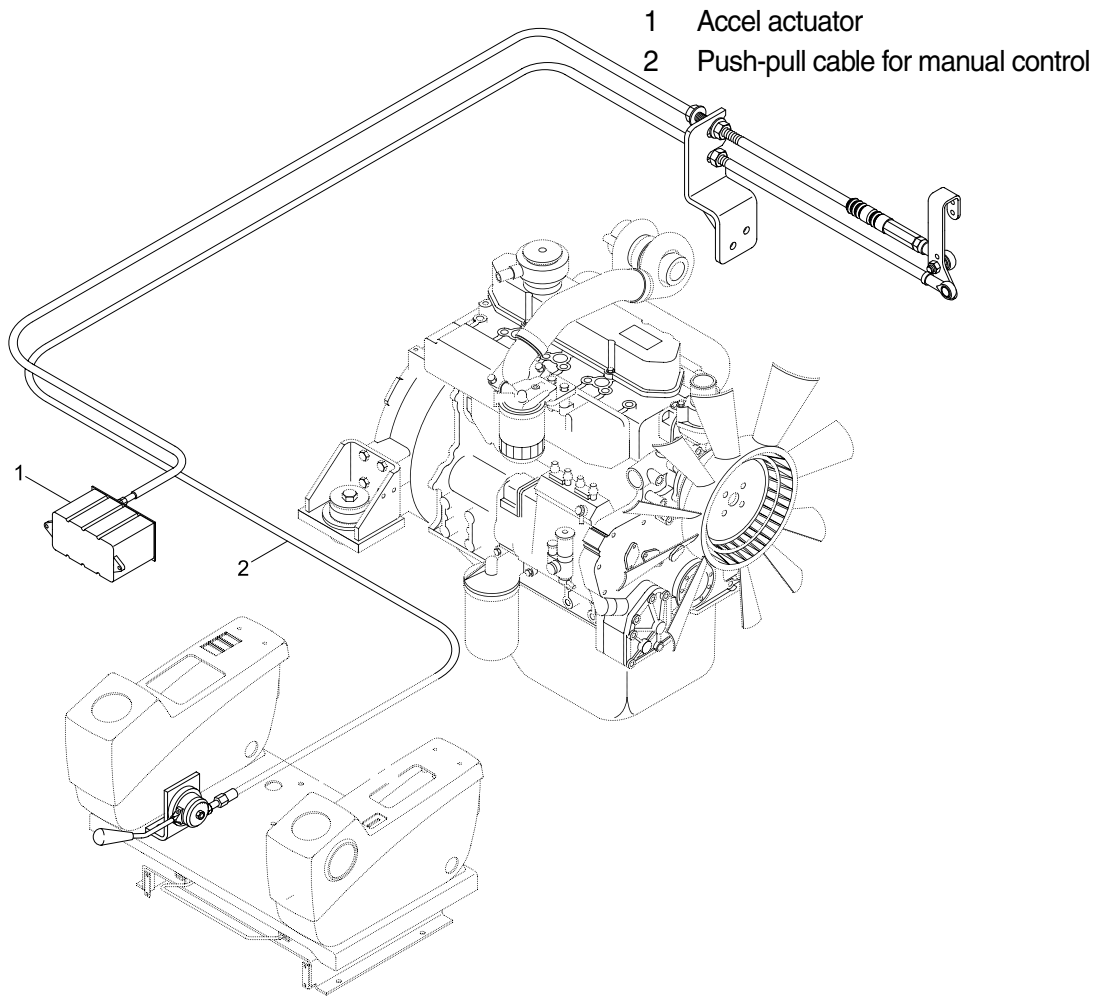

11075MS07

1) ENGINE THROTTLE LEVER

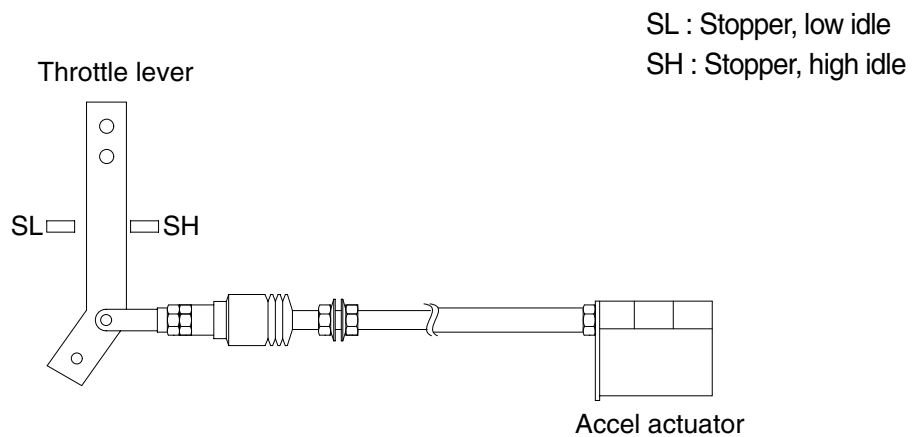

11075MS08

2) EMERGENCY CABLE (Push-pull cable)

It controls engine speed by connecting onto the lever of the injection pump when the malfunction of the CPU controller or the accel actuator happen.

3) ACCEL ACTUATOR

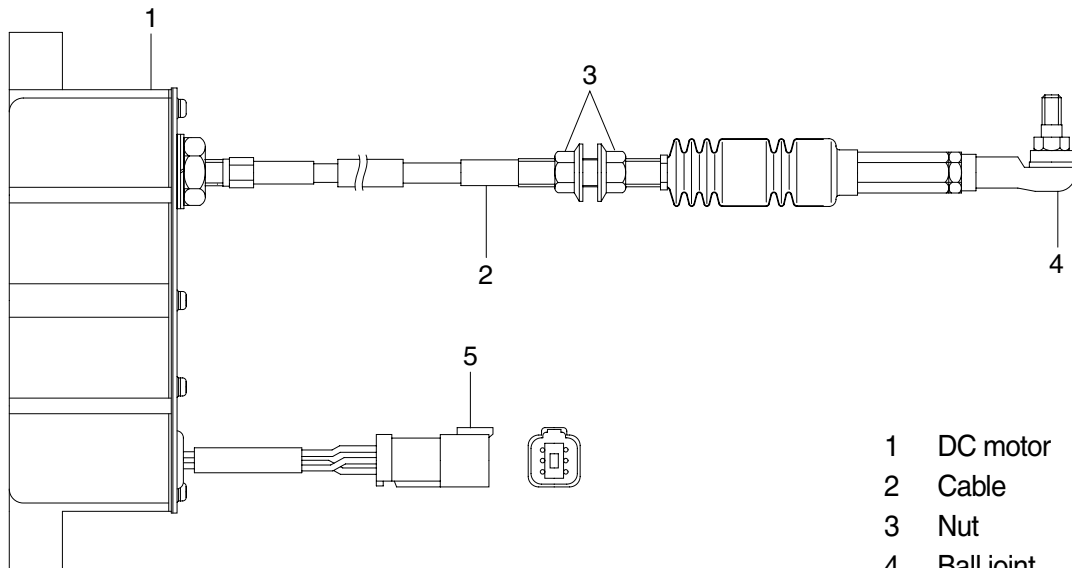

- 1 DC motor
- 2 Cable
- 3 Nut
- 4 Ball joint
- 5 Connector

11075MS09

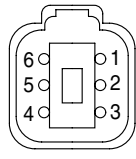
Connector		
Type	6P, female	
Line color & description	1	Green(Potentiometer 5V)
	2	White(Potentiometer SIG)
	3	Yellow(Potentiometer GND)
	4	-
	5	Red(Motor+)
	6	Blue(Motor -)
Inspection	Check resistance Spec : 10 Ω (Between No.5-6) 5kΩ (Between No.1-3)	

4) ACCEL ACTUATOR CABLE SETTING PROCEDURE

(1) Key ON

- ① Set the engine control dial max position and the one touch decel switch OFF.
- ② Connect the ball joint of cable to engine throttle lever.
- ③ Pull the cable to high stopper and put nut **A** edge to yoke of the bracket.
※ Make throttle lever not contact to the edge of high stopper.

(2) Key START

- ④ Confirm if the engine speed on cluster is same as each mode specification.
- ⑤ If the engine speed displayed on cluster is higher than each mode specification, then turn the nut **A** to counter clockwise and make the engine speed same to each mode specification.
- ⑥ If the engine speed displayed on cluster is lower than each mode specification, then turn the nut **A** to clockwise and make the engine speed same to each mode specification.
- ⑦ Turn nut **B** to clockwise and fix the cable to bracket.

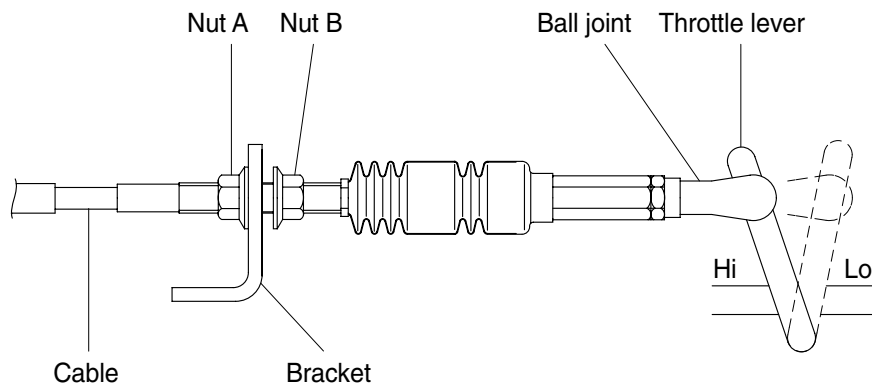

130W5MS05

Mode	RPM
H	2050 ± 50
S	1950 ± 50
L	1850 ± 50
Key start(one touch decel)	950 ± 100

5. ENGINE SPEED SENSOR

1) DETECT ACTUAL ENGINE RPM AND SEND SIGNAL TO TACHOMETER

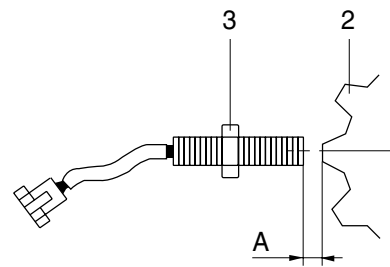
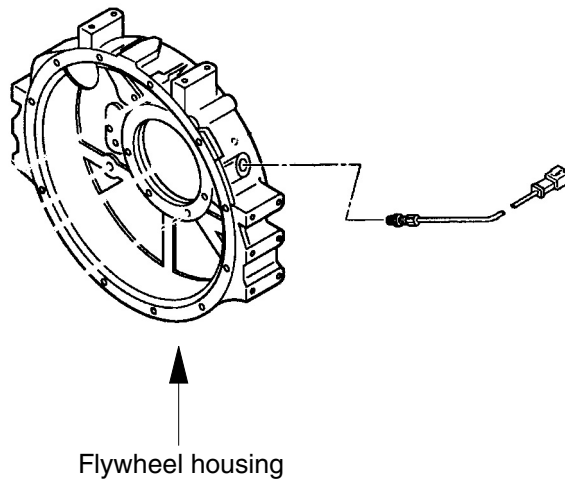

- 2 Gear teeth, flywheel
- 3 Lock nut, speed sensor
- A Clearance

11075MS10/R140LC-7 기타 5-20

2) INSTALLATION

- (1) Clean contacting point of sensor.
- (2) Loosen lock nut.
- (3) Screw speed sensor into flywheel housing.
- (4) Turn it back 135° when it contacts with gear teeth.
- (5) Tight lock nut and connect wiring.

3) INSPECTION

- (1) Check resistance
 - SPEC : 300 Ω
- (2) Check voltage while engine run.
 - SPEC : 2~28Vac, dependent on the engine speed(rpm)