

GROUP 3 ELECTRICAL SYSTEM

1. WHEN STARTING SWITCH IS TURNED ON, MONITOR PANEL DISPLAY DOES NOT APPEAR

- Before disconnecting the connector, always turn the starting switch OFF.
- Before carrying out below procedure, check all the related connectors are properly inserted and short of fuse No.8.
- After checking, insert the disconnected connectors again immediately unless otherwise specified.

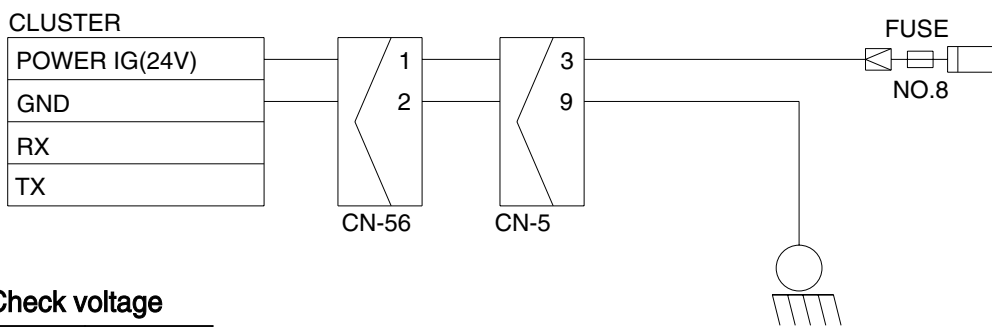
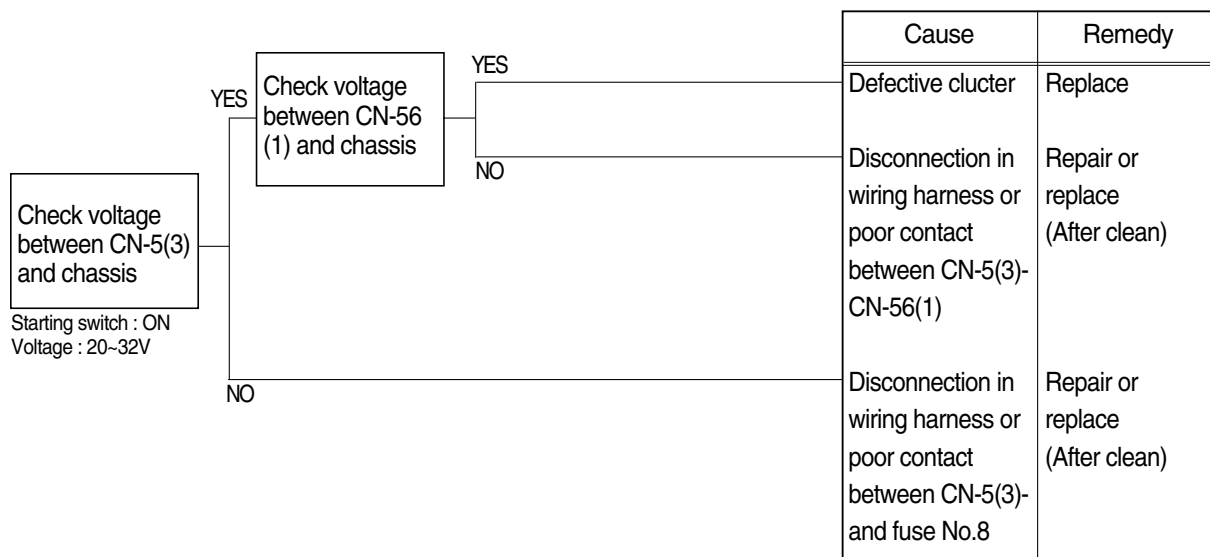

Check voltage

YES	20 ~ 30V
NO	0V

11076TS20

2. COMMUNICATION ERROR "Co : Err" FLASHES ON THE CLUSTER

- Before disconnecting the connector, always turn the starting switch OFF.
- Before carrying out below procedure, check all the related connectors are properly inserted.
- After checking, insert the disconnected connectors again immediately unless otherwise specified.

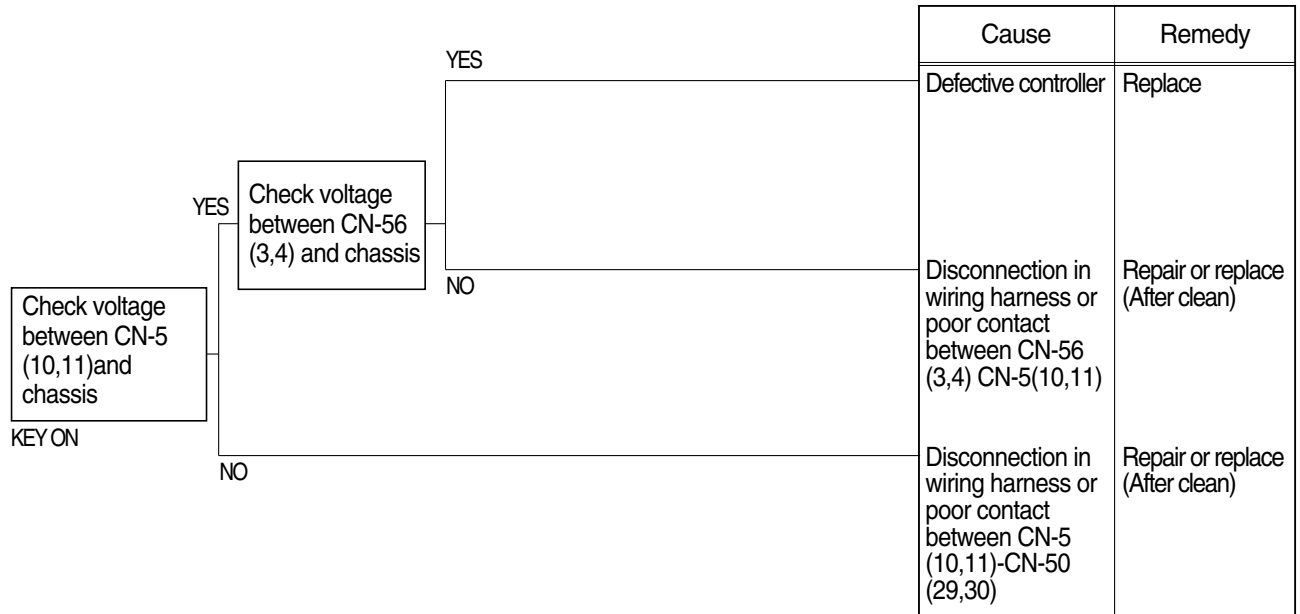

Check voltage

YES	*4V	*12V
NO	0V	0V

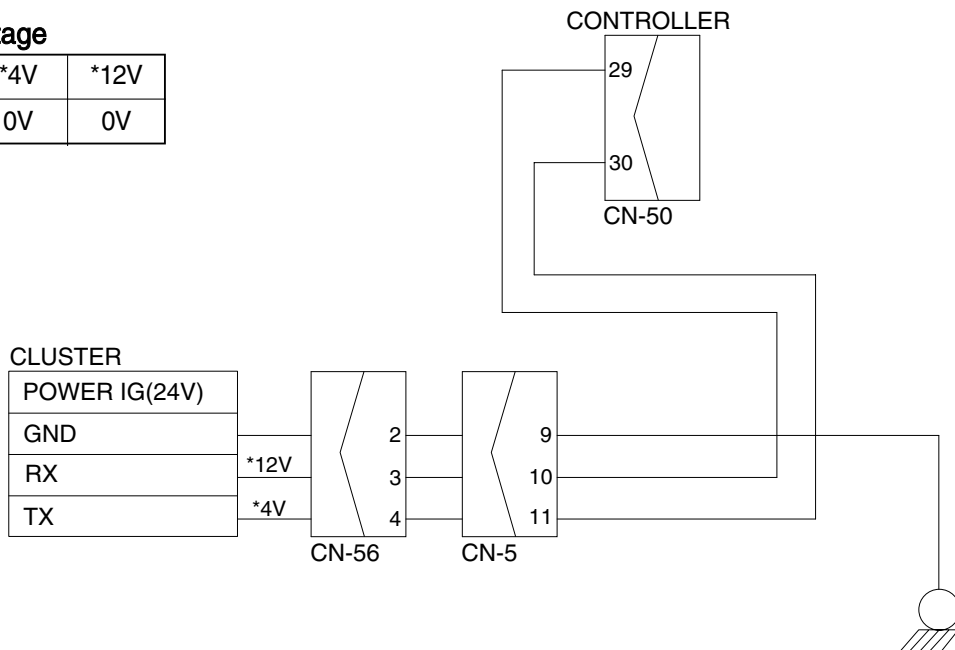

29076ES02

3. BATTERY CHARGING WARNING LAMP LIGHTS UP(Starting switch : ON)

- Before disconnecting the connector, always turn the starting switch OFF.
- Before carrying out below procedure, check all the related connectors are properly inserted.
- After checking, insert the disconnected connectors again immediately unless otherwise specified.

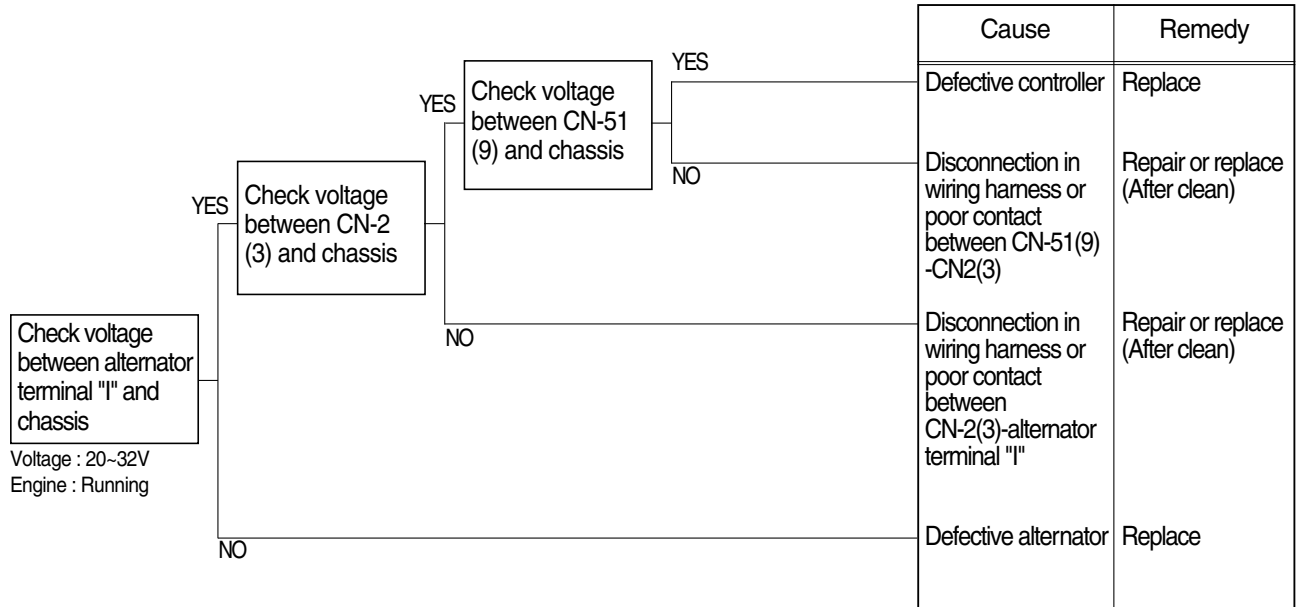

Check voltage

YES	20 ~ 32V
NO	0V

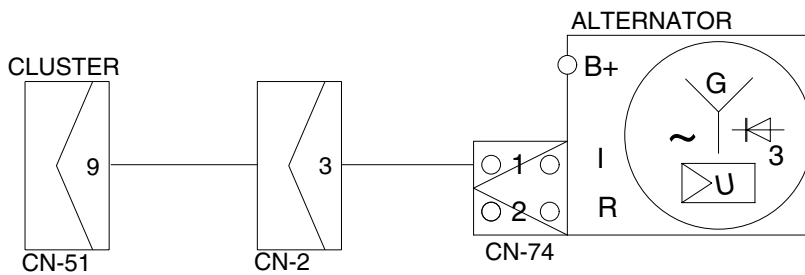

11076TS21

4. WHEN COOLANT OVERHEAT WARNING LAMP LIGHTS UP (Engine is started)

- Before disconnecting the connector, always turn the starting switch OFF.
- Before carrying out below procedure, check all the related connectors are properly inserted.
- After checking, insert the disconnected connectors again immediately unless otherwise specified.

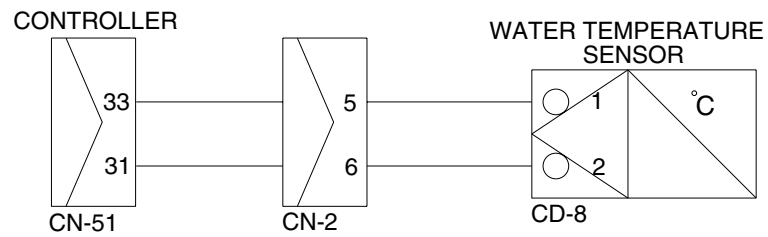
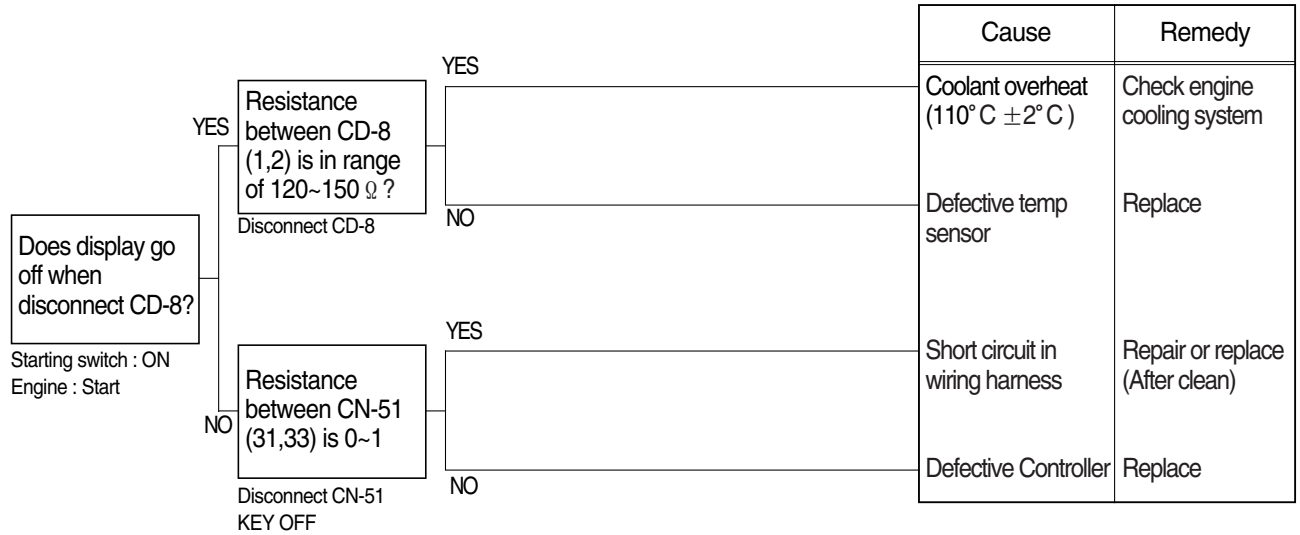

11076TS22

5. WHEN AIR CLEANER WARNING LAMP LIGHTS UP (Engine is started)

- Before disconnecting the connector, always turn the starting switch OFF.
- Before carrying out below procedure, check all the related connectors are properly inserted.
- After checking, insert the disconnected connectors again immediately unless otherwise specified.

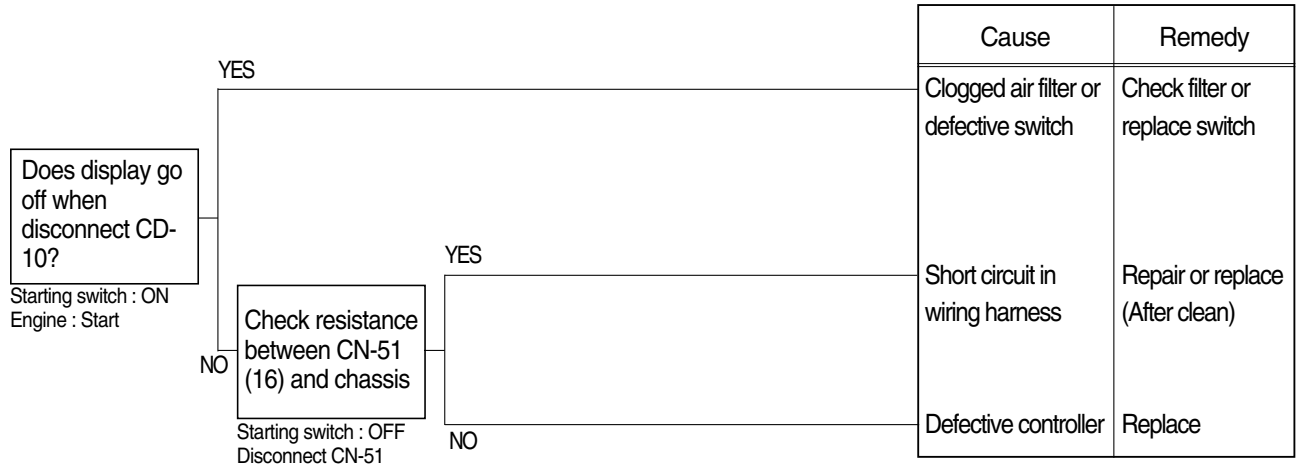

Check resistance

YES	MAX 1Ω
NO	MIN 1M Ω



25036EL05

6. WHEN ENGINE OIL PRESSURE WARNING LAMP LIGHTS UP(Engine is started)

- Before disconnecting the connector, always turn the starting switch OFF.
- Before carrying out below procedure, check all the related connectors are properly inserted.
- After checking, insert the disconnected connectors again immediately unless otherwise specified.

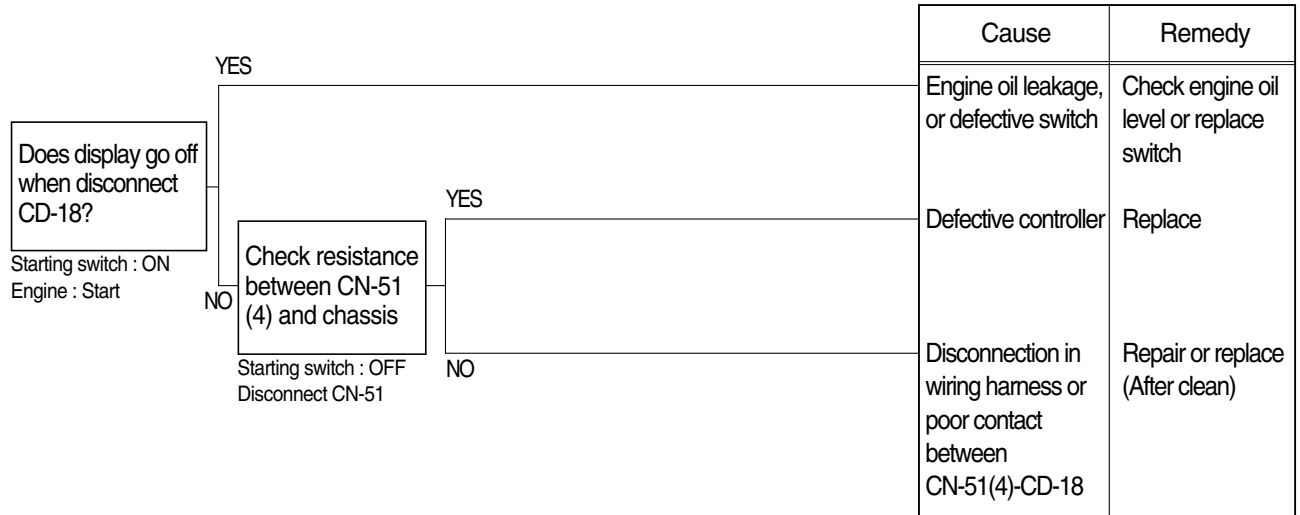

Check resistance

YES	MAX 1Ω
NO	MIN 1MΩ

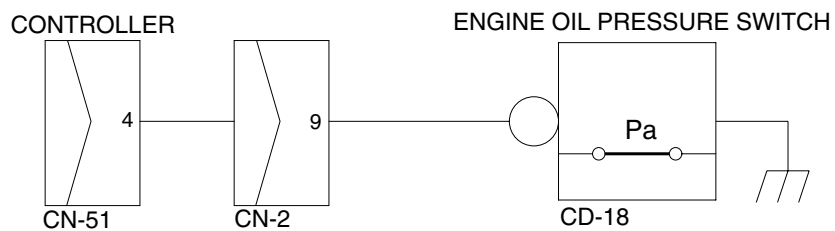

11076TS23

7. WHEN HYDRAULIC OIL TEMPERATURE WARNING LAMP LIGHTS UP(Engine is started)

- Before disconnecting the connector, always turn the starting switch OFF.
- Before carrying out below procedure, check all the related connectors are properly inserted.
- After checking, insert the disconnected connectors again immediately unless otherwise specified.

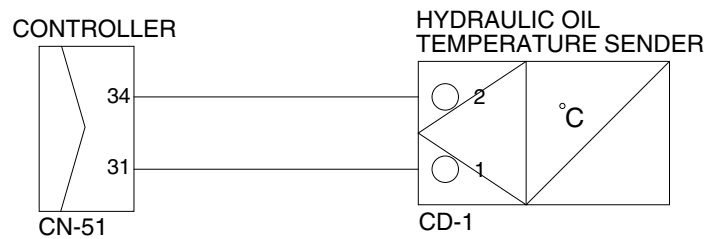
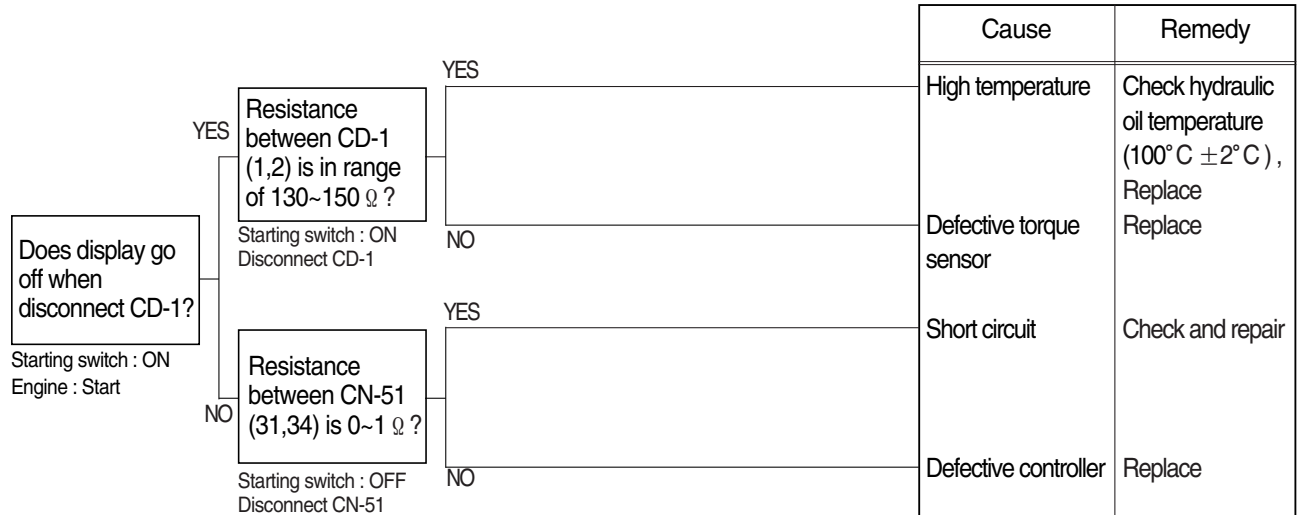

29076ES04

8. WHEN COOLANT LEVEL WARNING LAMP LIGHTS UP(Engine is started)

- Before disconnecting the connector, always turn the starting switch OFF.
- Before carrying out below procedure, check all the related connectors are properly inserted.
- After checking, insert the disconnected connectors again immediately unless otherwise specified.

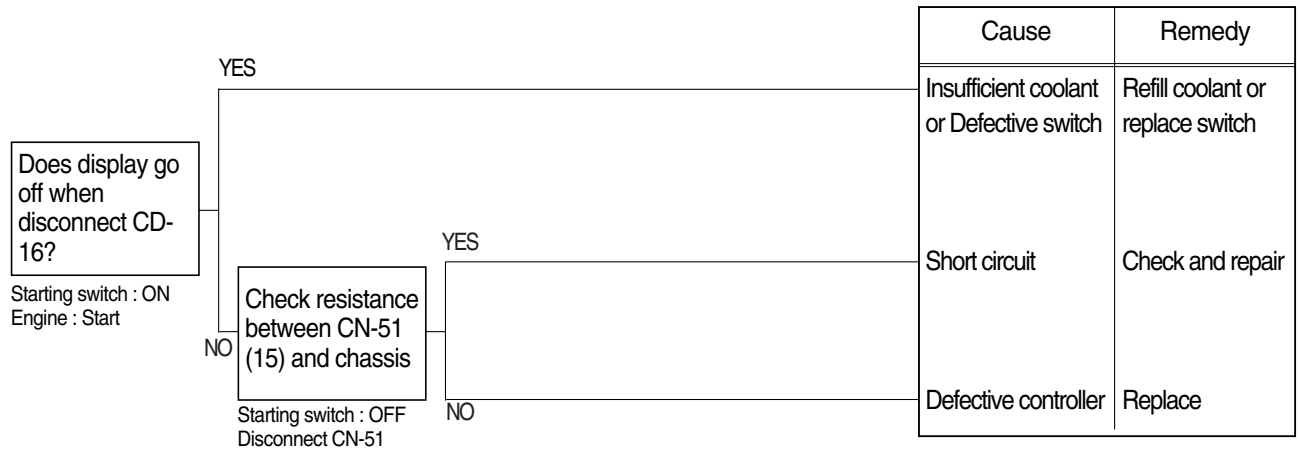

Check resistance

YES	MAX 1Ω
NO	MIN 1MΩ

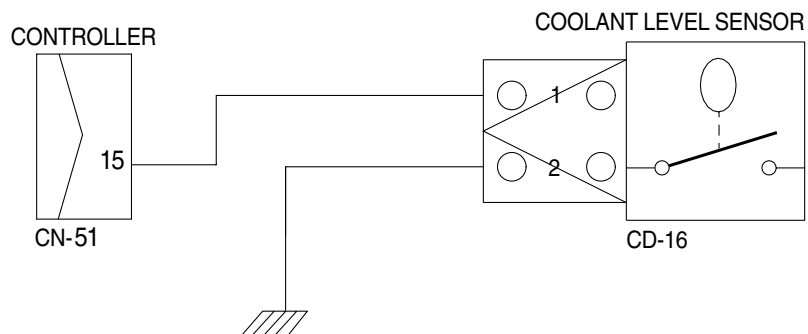

25076ES08

9. WHEN COOLANT TEMPERATURE GAUGE DOES NOT OPERATE

- Before disconnecting the connector, always turn the starting switch OFF.
- Before carrying out below procedure, check all the related connectors are properly inserted.
- After checking, insert the disconnected connectors again immediately unless otherwise specified.

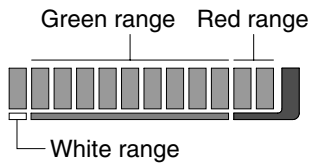
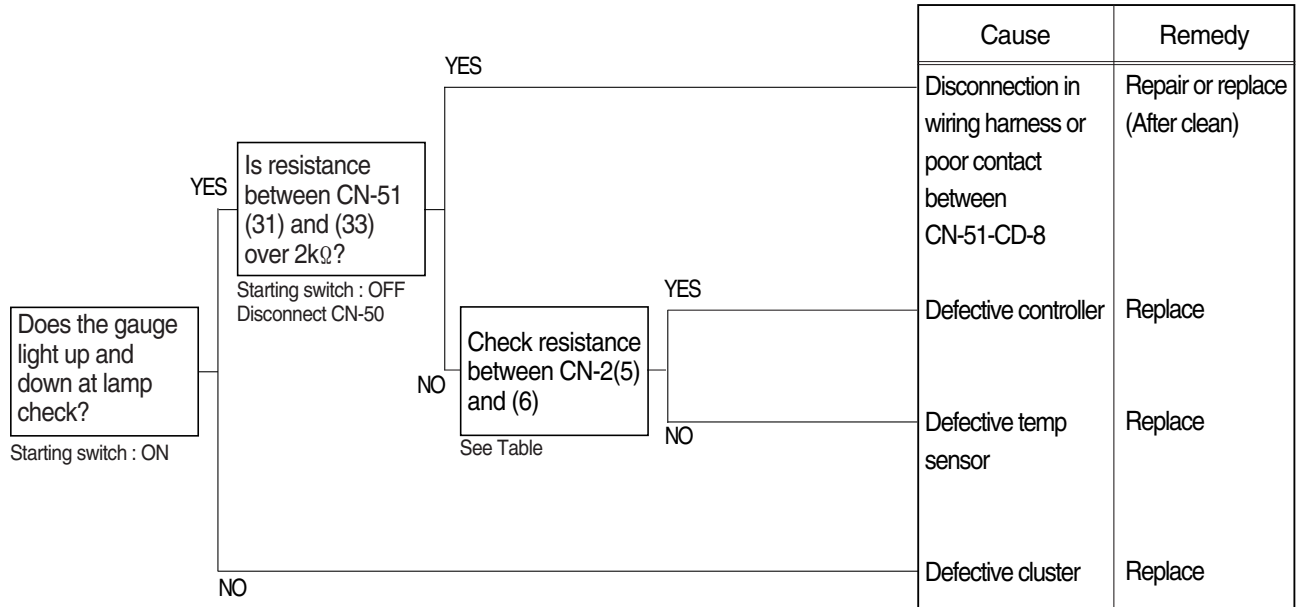

Check Table

Temperature Item	White range (~29°C)	Green range (30~105°C)	Red range (105°C ~)
Unit Resistance(Ω)	1646~	1645~158	~139
Tolerance(%)	±20	±20	±20

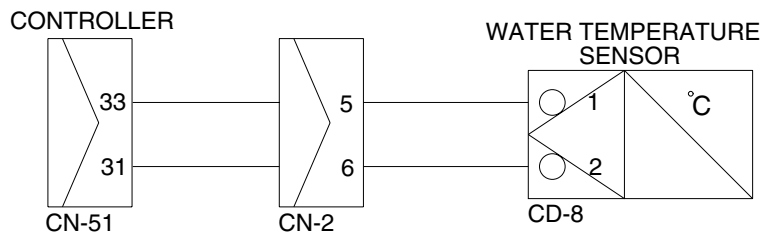

10. WHEN FUEL GAUGE DOES NOT OPERATE(Check warning lamp ON/OFF)

- Before disconnecting the connector, always turn the starting switch OFF.
- Before carrying out below procedure, check all the related connectors are properly inserted.
- After checking, insert the disconnected connectors again immediately unless otherwise specified.

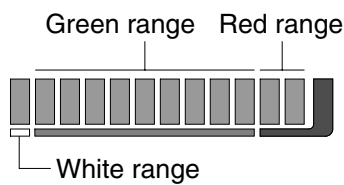
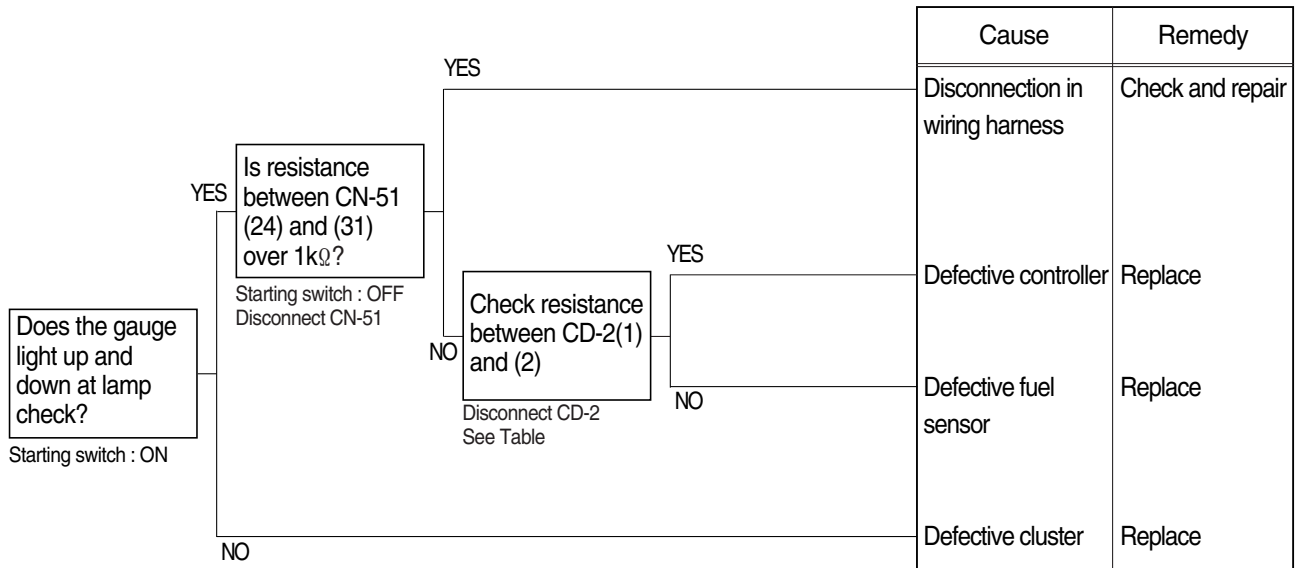

Check Table

Item \ Level	White range	Green range	Red range
Unit Resistance(Ω)	700~601	600~101	~100
Tolerance(%)	±5	±5	±5

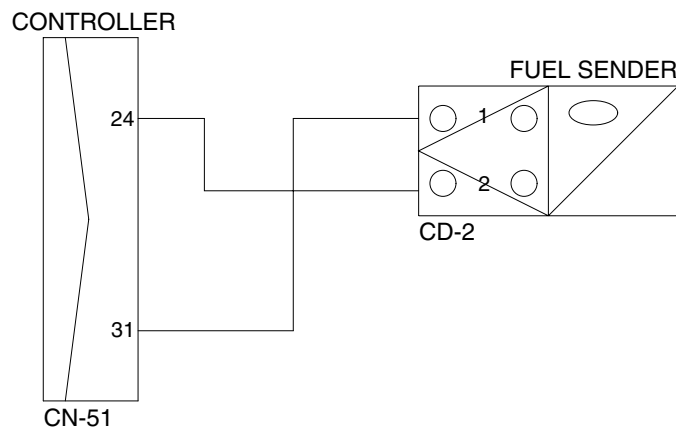

29076ES06

11. WHEN SAFETY SOLENOID DOES NOT OPERATE

- Before disconnecting the connector, always turn the starting switch OFF.
- Before carrying out below procedure, check all the related connectors are properly inserted and short of fuse No.24.
- After checking, insert the disconnected connectors again immediately unless otherwise specified.

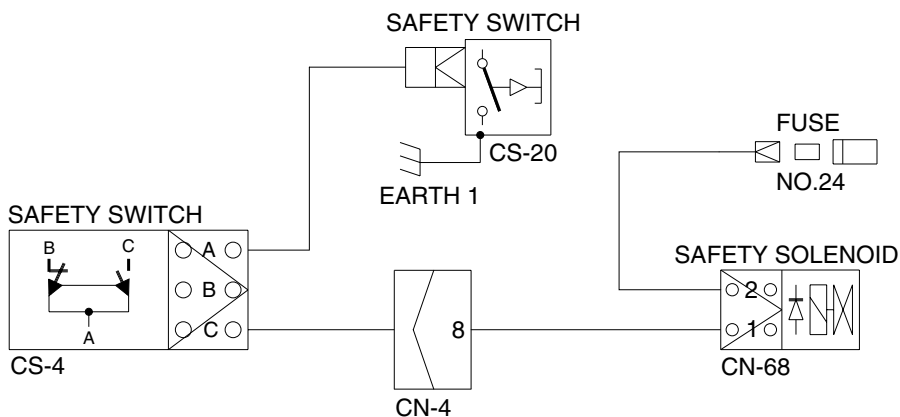
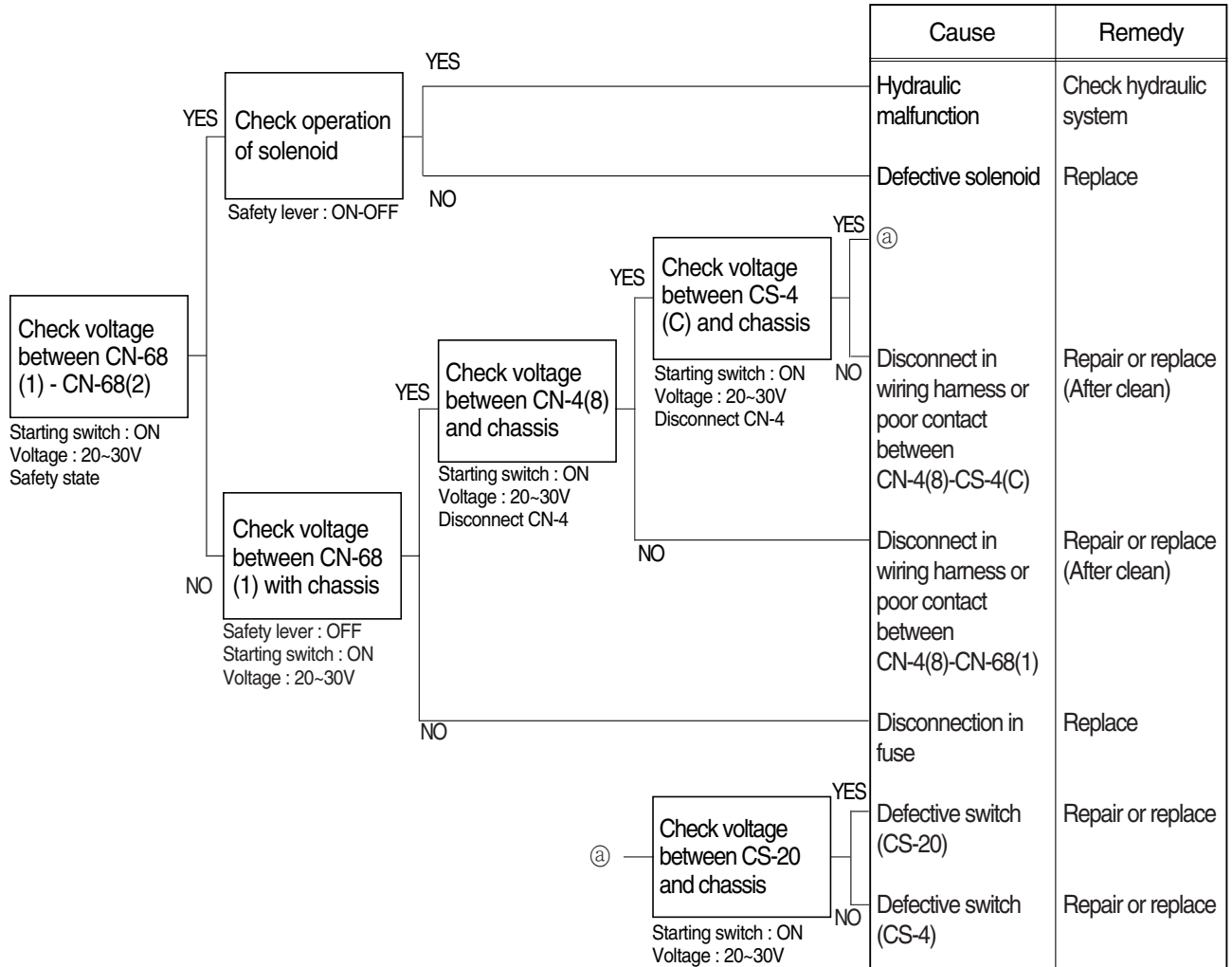

12. WHEN TRAVEL SPEED 1, 2 DOES NOT OPERATE

- Before disconnecting the connector, always turn the starting switch OFF.
- Before carrying out below procedure, check all the related connectors are properly inserted and short of fuse No.22 .
- After checking, insert the disconnected connectors again immediately unless otherwise specified.

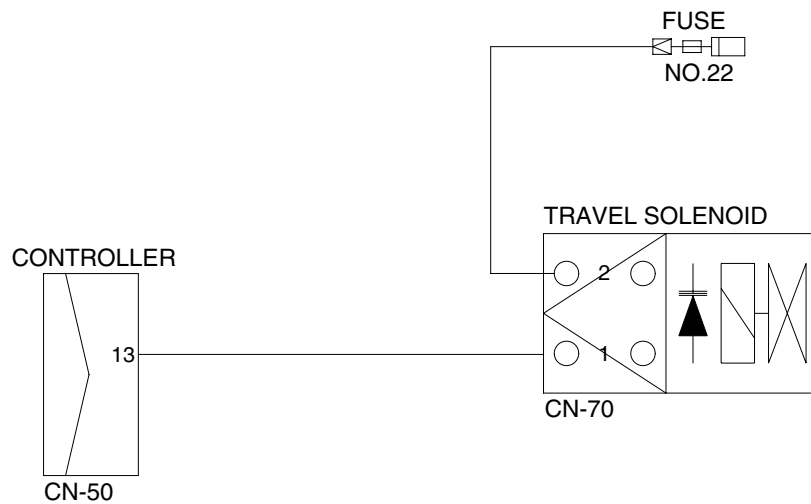
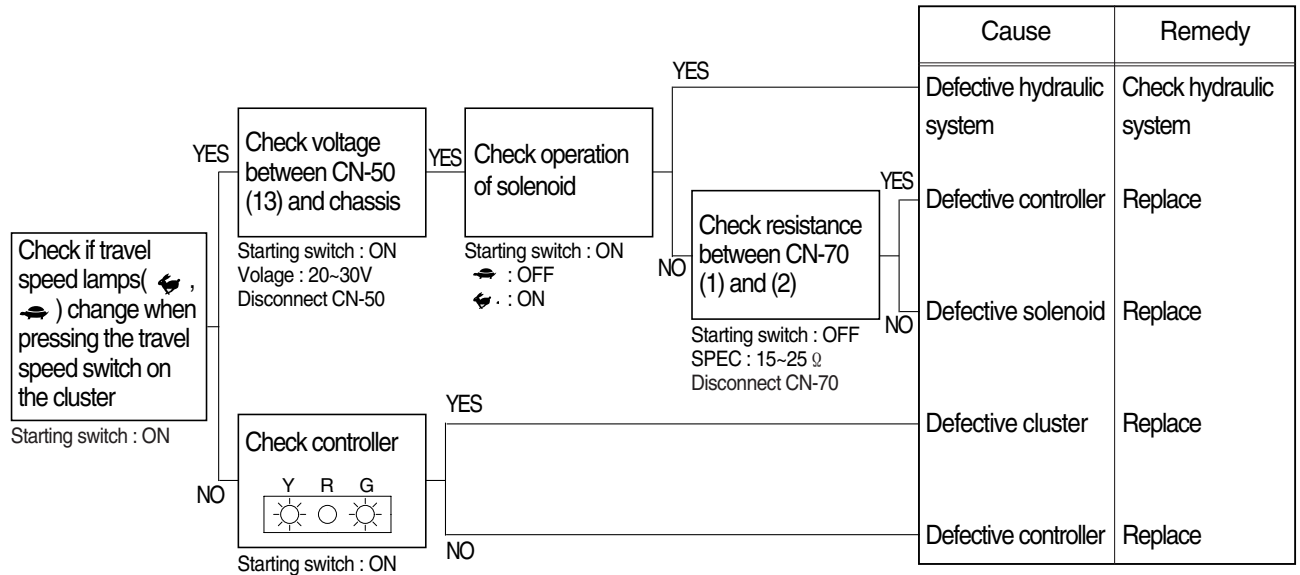

21076ES04

13. WHEN STARTING SWITCH IS TURNED ON, HEAD LAMP DOES NOT LIGHTS UP

- Before disconnecting the connector, always turn the starting switch OFF.
- Before carrying out below procedure, check all the related connectors are properly inserted and short of fuse No.14.
- After checking, insert the disconnected connectors again immediately unless otherwise specified.

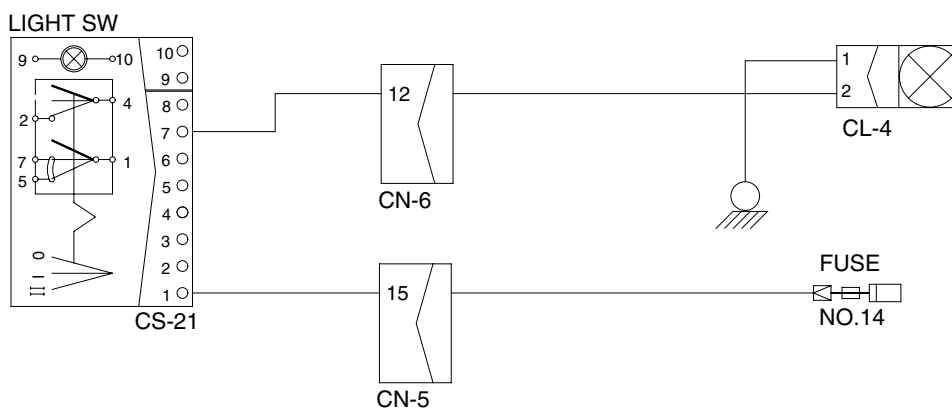
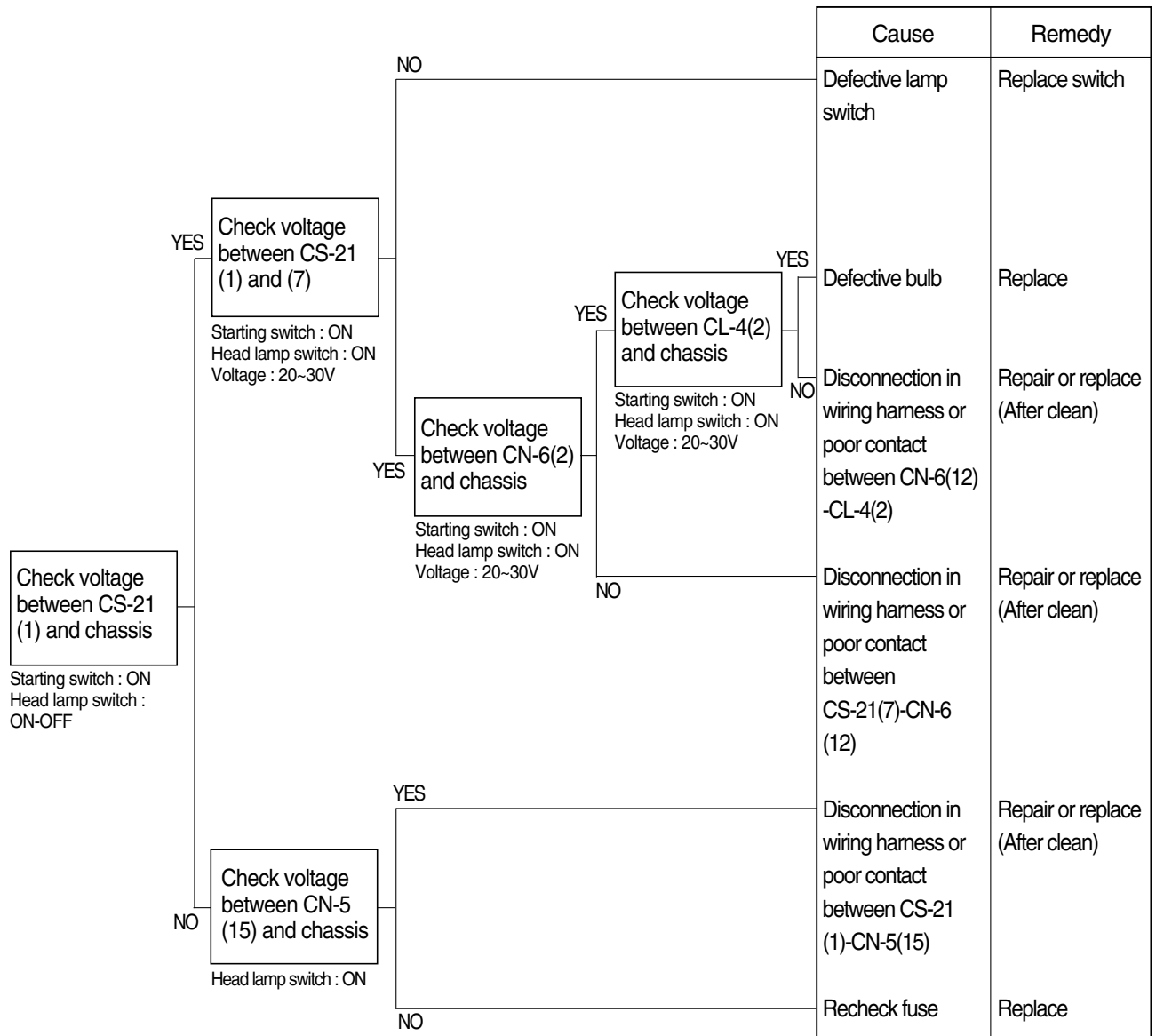

11076TS27

14. WHEN STARTING SWITCH IS TURNED ON, WORK LAMP DOES NOT LIGHTS UP

- Before disconnecting the connector, always turn the starting switch OFF.
- Before carrying out below procedure, check all the related connectors are properly inserted and short of fuse No.15.
- After checking, insert the disconnected connectors again immediately unless otherwise specified.

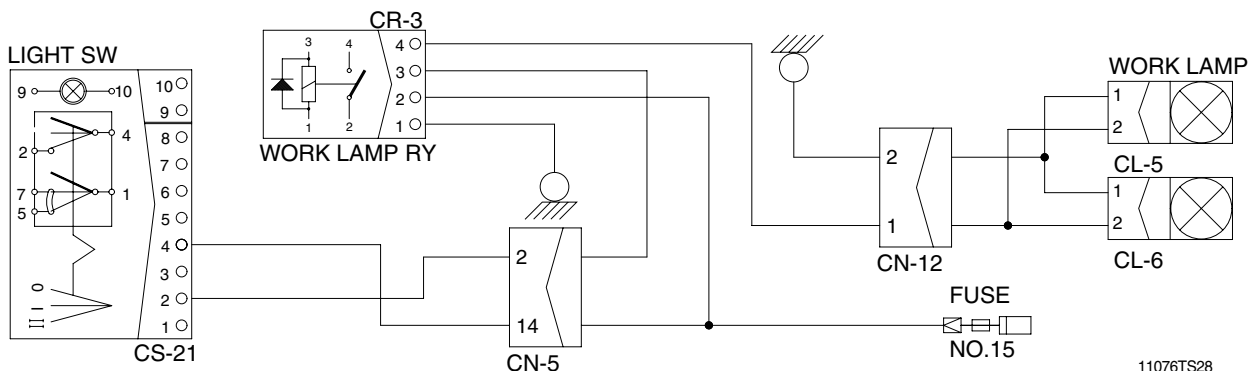
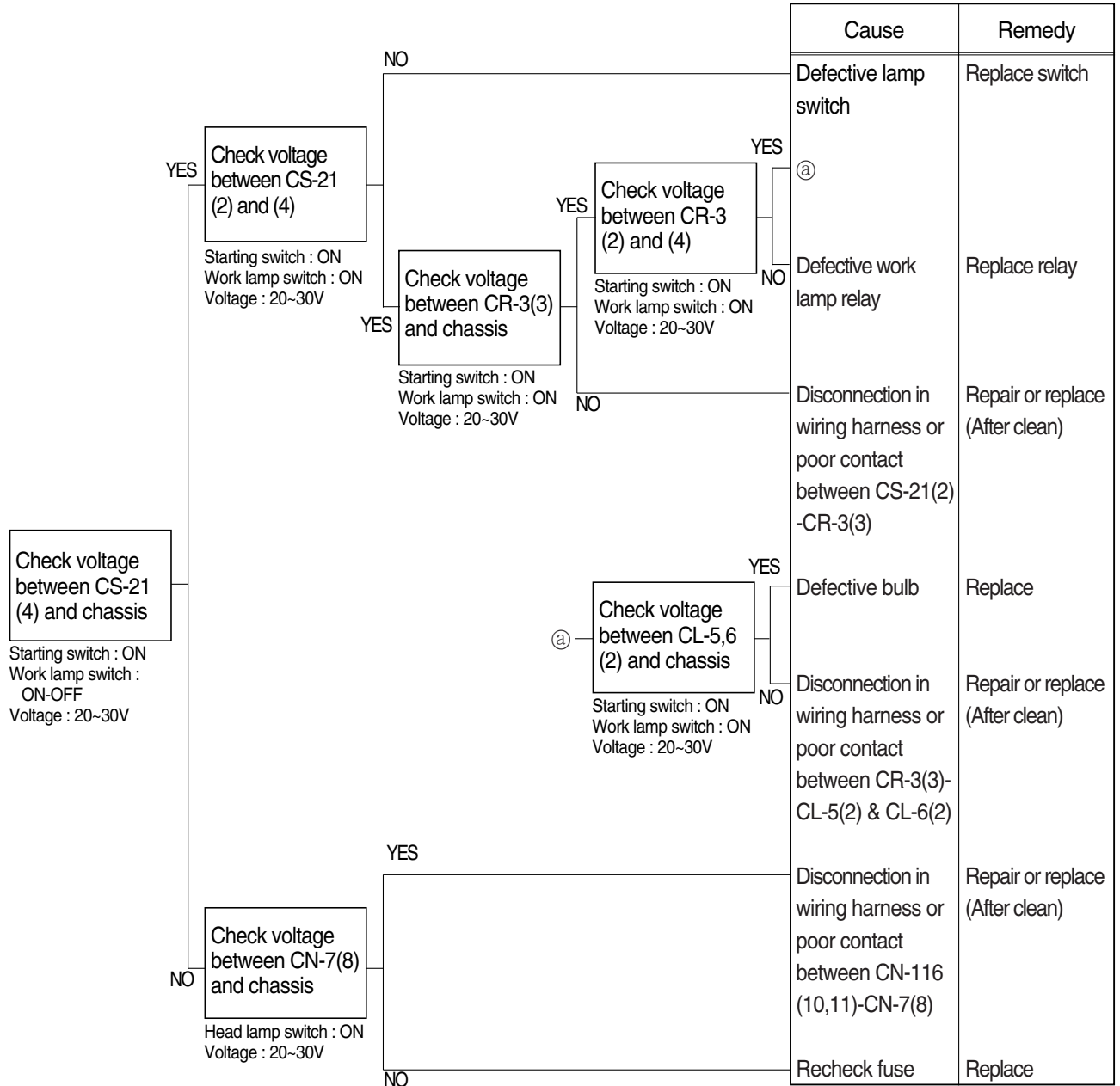

11076TS28

15. WHEN ENGINE DOES NOT START

- Check supply of the power at engine stop solenoid while starting switch is ON.
- Before disconnecting the connector, always turn the starting switch OFF.
- Before carrying out below procedure, check all the related connectors are properly inserted.
- After checking, insert the disconnected connectors again immediately unless otherwise specified.

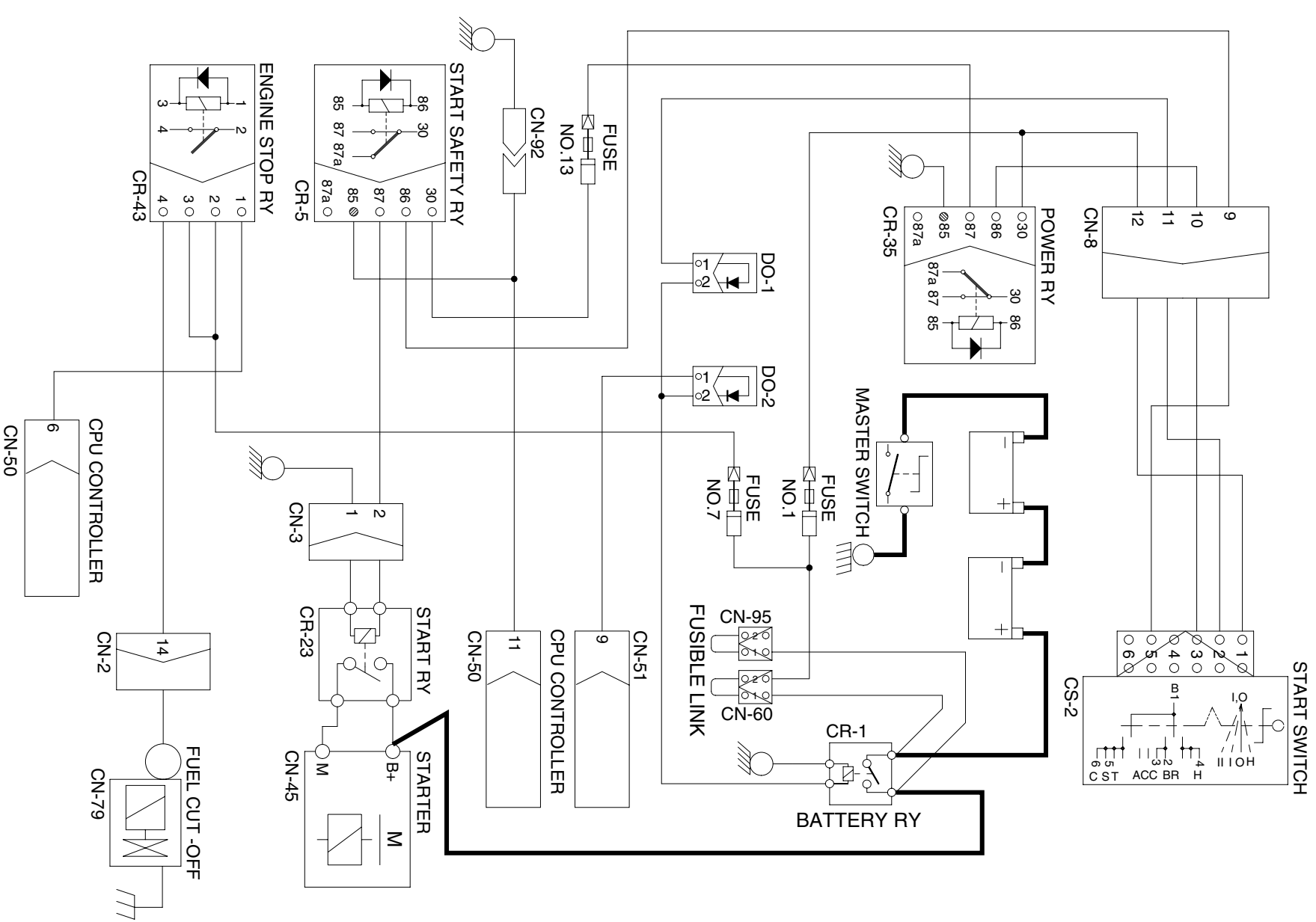
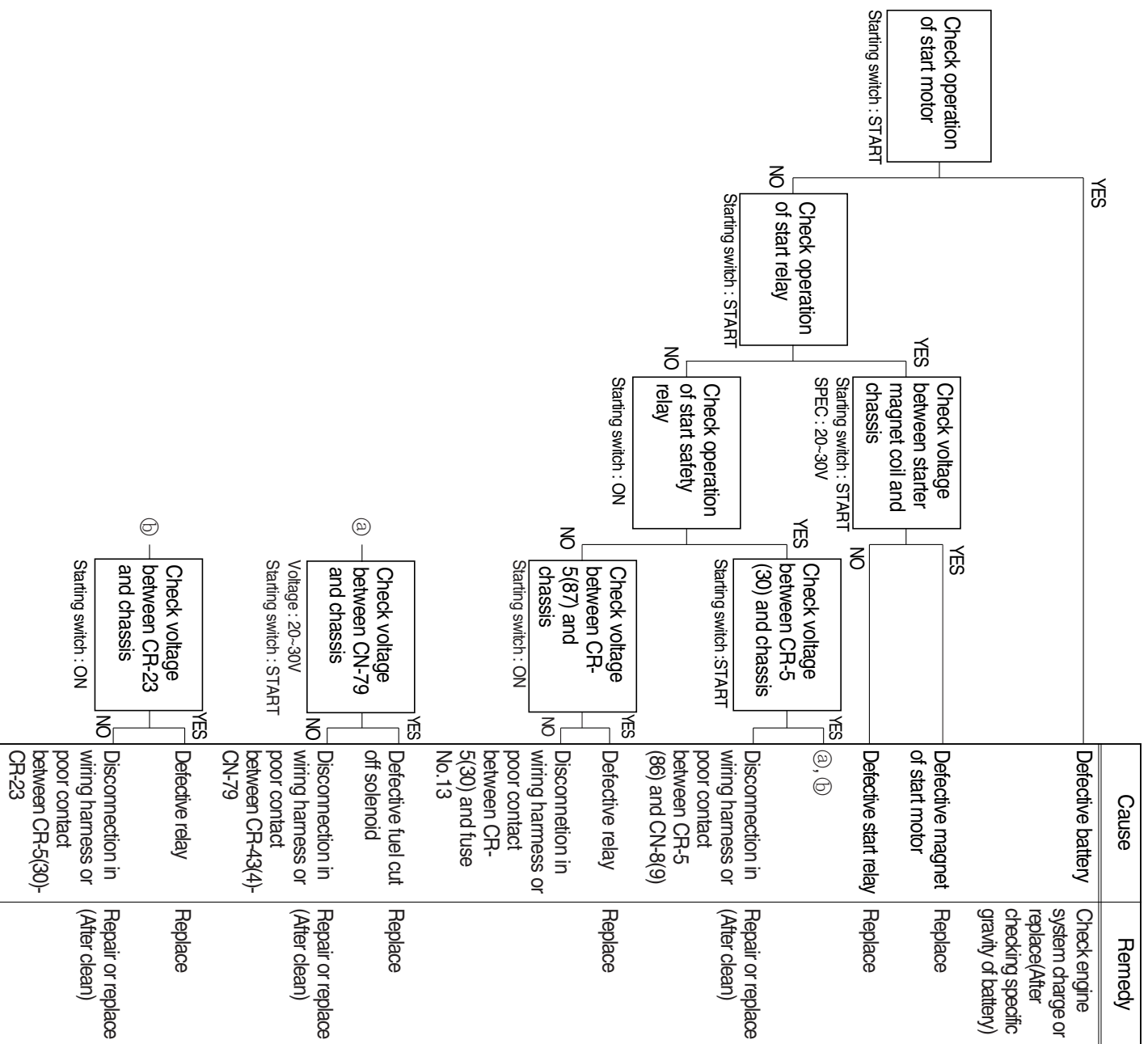

16. WHEN STARTING SWITCH ON DOES NOT OPERATE

- Before disconnecting the connector, always turn the starting switch OFF.
- Before carrying out below procedure, check all the related connectors are properly inserted and master switch ON.
- After checking, insert the disconnected connectors again immediately unless otherwise specified.

Cause	Remedy
Disconnection in wiring harness or poor contact between DO-2(1) and DO-2(2)-CR-1 or defective battery relay	Repair or replace (After clean)
Disconnection in wiring harness or poor contact between CS-2(2)-CN-8(11)-DO-2(1)	Replace
Defective start switch	Replace
Disconnection in wiring harness or poor contact between CS-2(1)-CN-8(12)-CR-1-Battery	Replace
Battery capacity too low	Charge or replace (After clean)

YES	Check voltage between CS-2(1) and chassis Voltage : 20-30V	YES	Check voltage between CS-2(2) and chassis Voltage : 20-30V	YES	Check voltage between DO-2(1) and chassis Voltage : 20-30V
NO		NO		NO	

Check voltage and specific gravity of battery Specific gravity : MIN 1.28 Voltage : MIN 24V	NO	
---	----	--

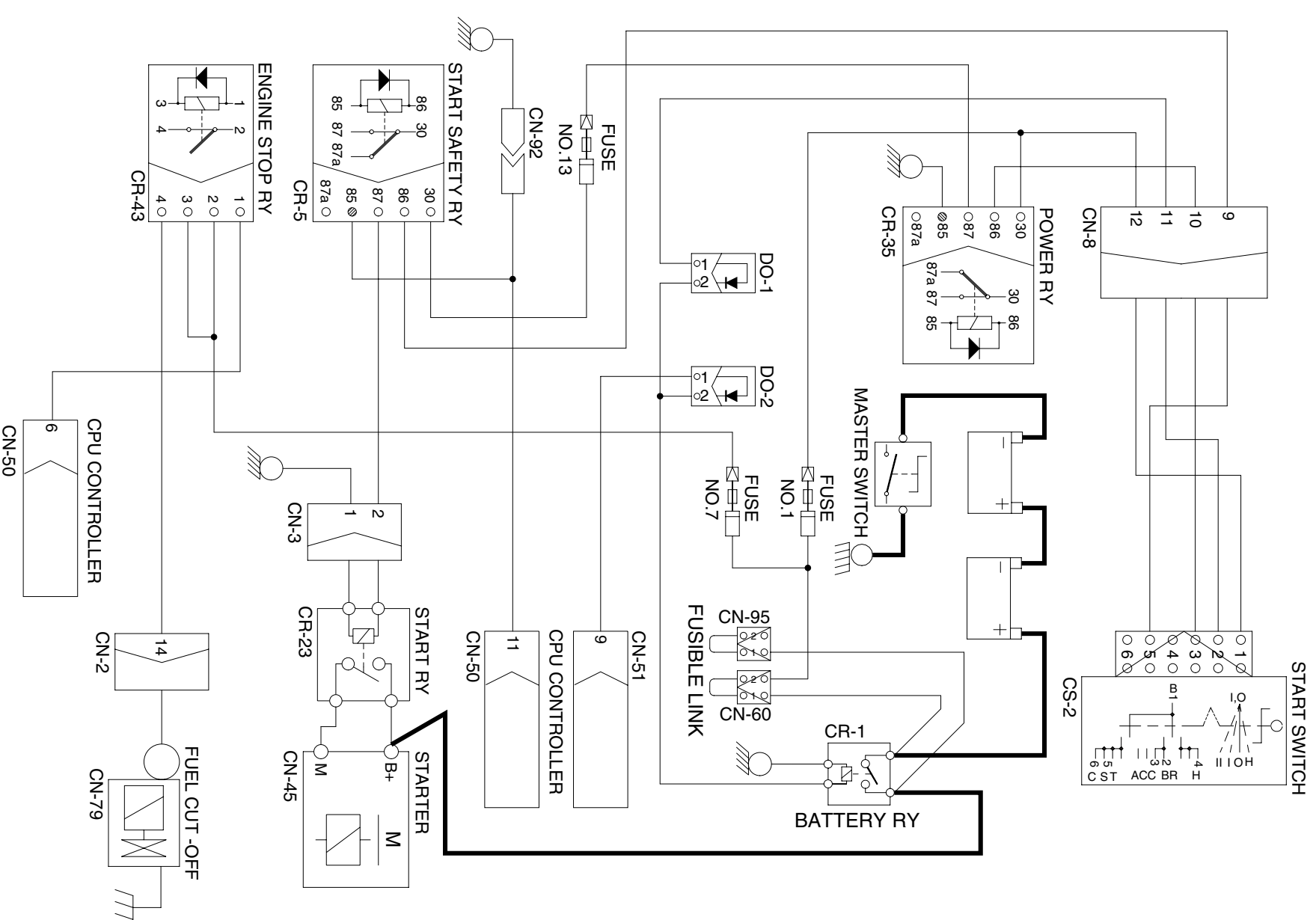

17. WHEN STARTING SWITCH IS TURNED ON, WIPER MOTOR DOES NOT OPERATE

- Before disconnecting the connector, always turn the starting switch OFF
- Before carrying out below procedure, check all the related connectors are properly inserted and the fuse No.4, 8 and 13 is not blown out.
- After checking, insert the disconnected connectors again immediately unless otherwise specified.

Check operation	YES	NO	Cause	Remedy
Check operation wiper cut switch	YES	NO	Defective wiper cut switch	Replace
Check voltage between CN-141 (11) and chassis	YES	NO	Disconnection in wiring harness or poor contact between CN-141 (11) - CS-53	Repair or replace (After clean)
Check operation of cluster LED ON.	YES	NO	Defective cluster	Replace
Check voltage between CN-56 (1) and chassis	YES	NO	1) Recheck fuse NO.8 2) Disconnection in wiring harness or poor contact between CN-56(1)-Fuse between CN-56(2)-Chassis	Replace Repair or replace (After clean)
Check voltage between CN-50(14) and chassis	YES	NO	Defective CPU controller	Replace
Check voltage between CN-50 (16) and chassis	YES	NO	1) Recheck fuse NO.4 2) Disconnection in wiring harness or poor contact between CN-141(7)-Fuse, CN-21(4)-Fuse	Replace Repair or replace (After clean)
Check operation of wiper motor and controller check voltage CN-141(7) and chassis, CN-21(4)	YES	NO	1) Recheck fuse NO.13 2) Disconnection CN-141(6)-Fuse	Replace Repair or replace (After clean)
Check voltage between CN-50 (15) and chassis	YES	NO	1) Recheck fuse NO.13 2) Disconnection CN-141(6)-Fuse	Replace Repair or replace (After clean)
Check continuity between CN-141(2)-CN-50(15), CN-141(9)-CN-50(16), CN-141(10)-CN-50(14), CN-141(5)-Chassis, CN-141(1)-CN-21(5), CN-141(3)-CN-21(6), CN-141(4)-CN-21(2), CN-141(13)-CN-21(3)	YES	NO	Disconnection in wiring harness or poor contact	Repair or replace (After clean)
Check wiper motor resistance between CN-21 (2)-CN-21(6)	YES	NO	Defective wiper motor	Replace
Check wiper motor resistance between CN-21 (2)-CN-21(6)	YES	NO	Defective wiper motor controller	Replace

