

1. POWER CIRCUIT

The negative terminal of battery is grounded to the machine chassis.

When the start switch is in the OFF position, the current flows from the positive battery terminal as shown below.

1) OPERATING FLOW

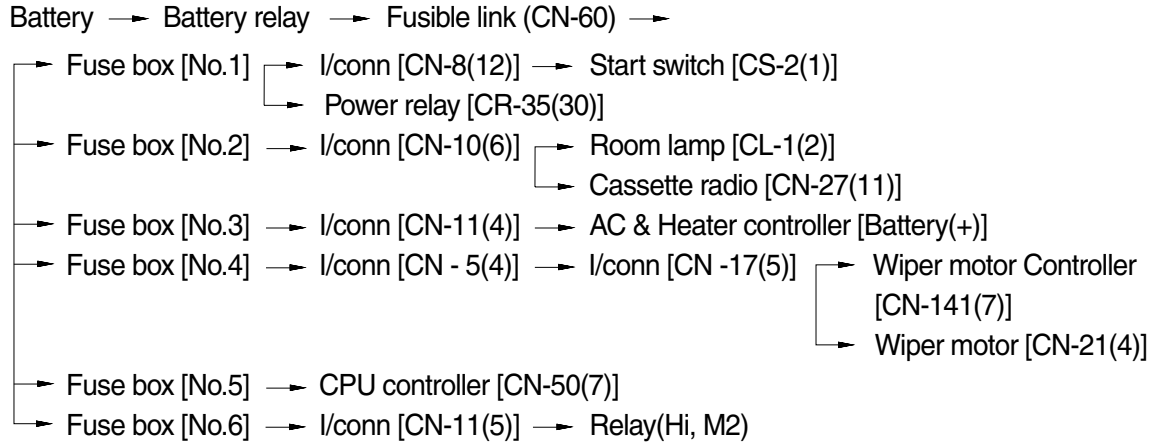

※ I/conn : Intermediate connector

2) CHECK POINT

Engine	Start switch	Check point	Voltage
OFF	OFF	① - GND (Battery 2 EA) ② - GND (Battery 2 EA) ③ - GND (Fusible link)	20~25V 20~25V 20~25V

※ GND : Ground

POWER CIRCUIT

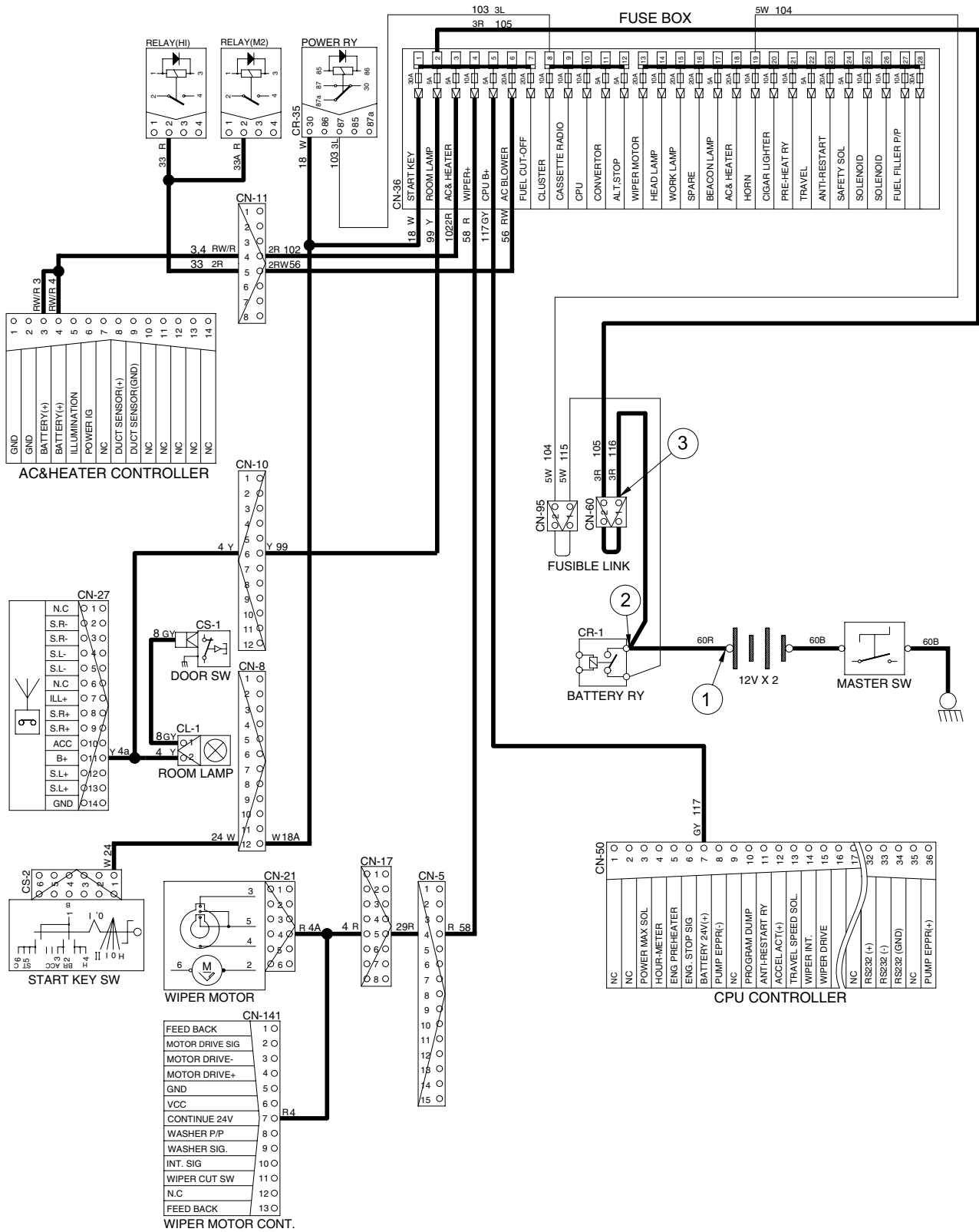

2. STARTING CIRCUIT

1) OPERATING FLOW

Battery(+) terminal → Battery relay[CR-1] → Fusible link → Fuse box No.1
 → I/conn [CN-8(12)] → Start key [CS-2(1)]

※ Start switch : ON

→ Start switch ON [CS-2(2)] → I/conn [CN-8(11)] → Diode[DO-2] →
 Battery relay [CR-1]:Battery relay operating(All power is supplied with the electric component)
 → Start switch ON [CS-2(3)] → I/conn [CN-8(10)] →
 GPS Connector[CN-125(2) → CN-125(4)] → Power relay [CR-35(86) → (87)] →
 Fuse box No.12 → I/conn [CN-2(4)] → Alterlator[CN-74(2)]

※ Start switch : START

Start switch START[CS-2(5)] → I/conn[CN-8(9)] → Anti-restart relay [CR-5(86) → (30)]
 → I/conn [CN-2(2)] → Start relay [CR-23]

2) CHECK POINT

Engine	Start switch	Check point	Voltage
Operating	Start	① - GND (Battery) ② - GND (Start key) ③ - GND (Battery relay M4) ④ - GND (Starter B) ⑤ - GND (Starter M) ⑥ - GND (Start relay) ⑦ - GND (Battery relay M8)	20 ~ 25V

※ GND : Ground

STARTING CIRCUIT

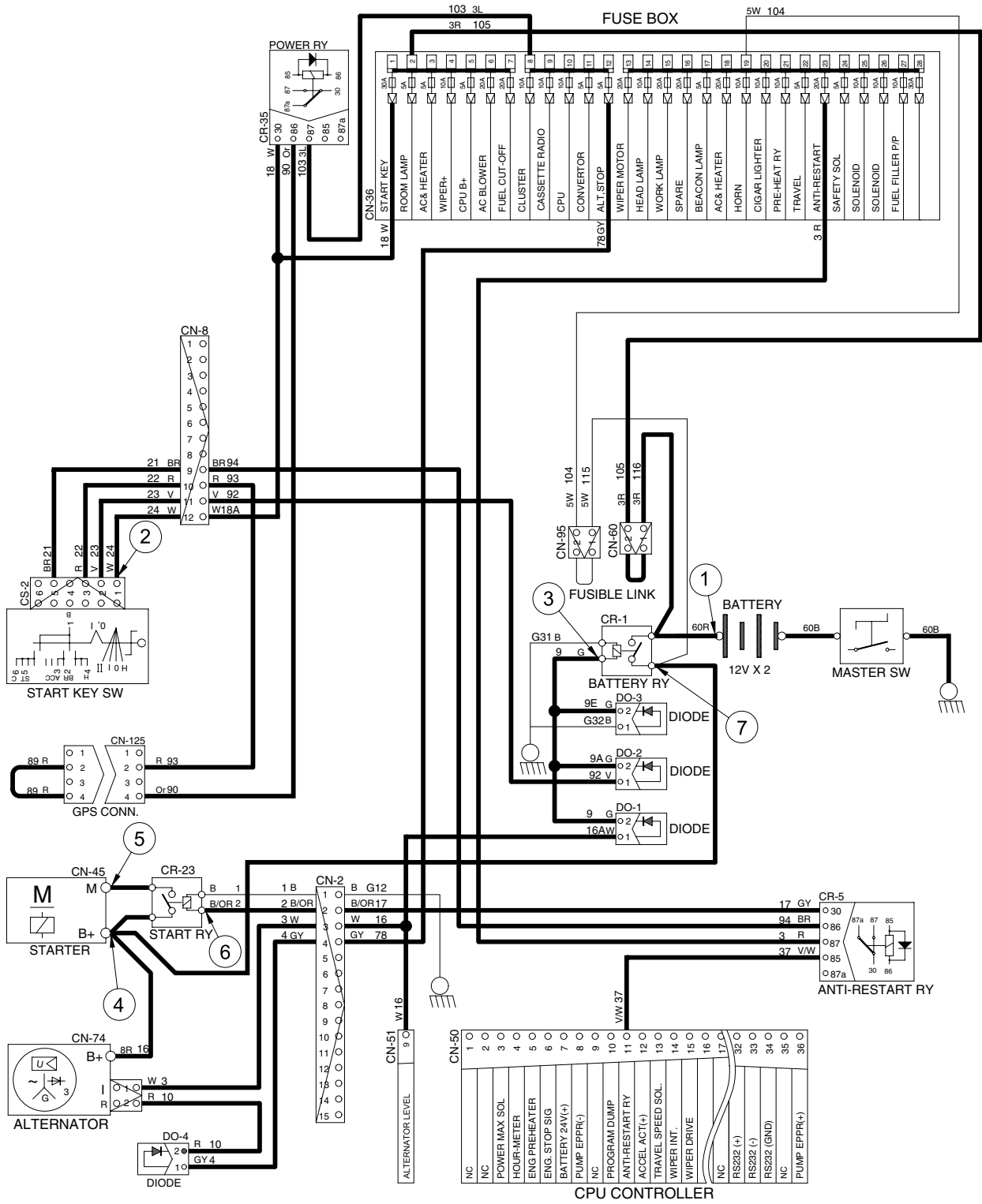

3. CHARGING CIRCUIT

When the starter is activated and the engine is started, the operator releases the key switch to the ON position.

Charging current generated by operating alternator flows into the battery through the Battery relay(CR-1).

The current also flows from alternator to each electrical component and controller through the fuse box.

1) OPERATING FLOW

(1) Warning flow

Alternator "I" terminal → I/conn [CN-2(3)] → CPU Controller [CN-51(9)] → Cluster warning lamp (Via serial interface)

(2) Charging flow

Alternator "B+" terminal → Battery relay → Battery(+) terminal
 → Fusible link → Fuse box

2) CHECK POINT

Engine	Start switch	Check point	Voltage
ON	ON	① - GND (Battery voltage) ② - GND (Battery relay) ③ - GND (Alternator B terminal) ④ - GND (Alternator I terminal) ⑤ - GND (CPU)	20~27V

※ GND : Ground

CHARGING CIRCUIT

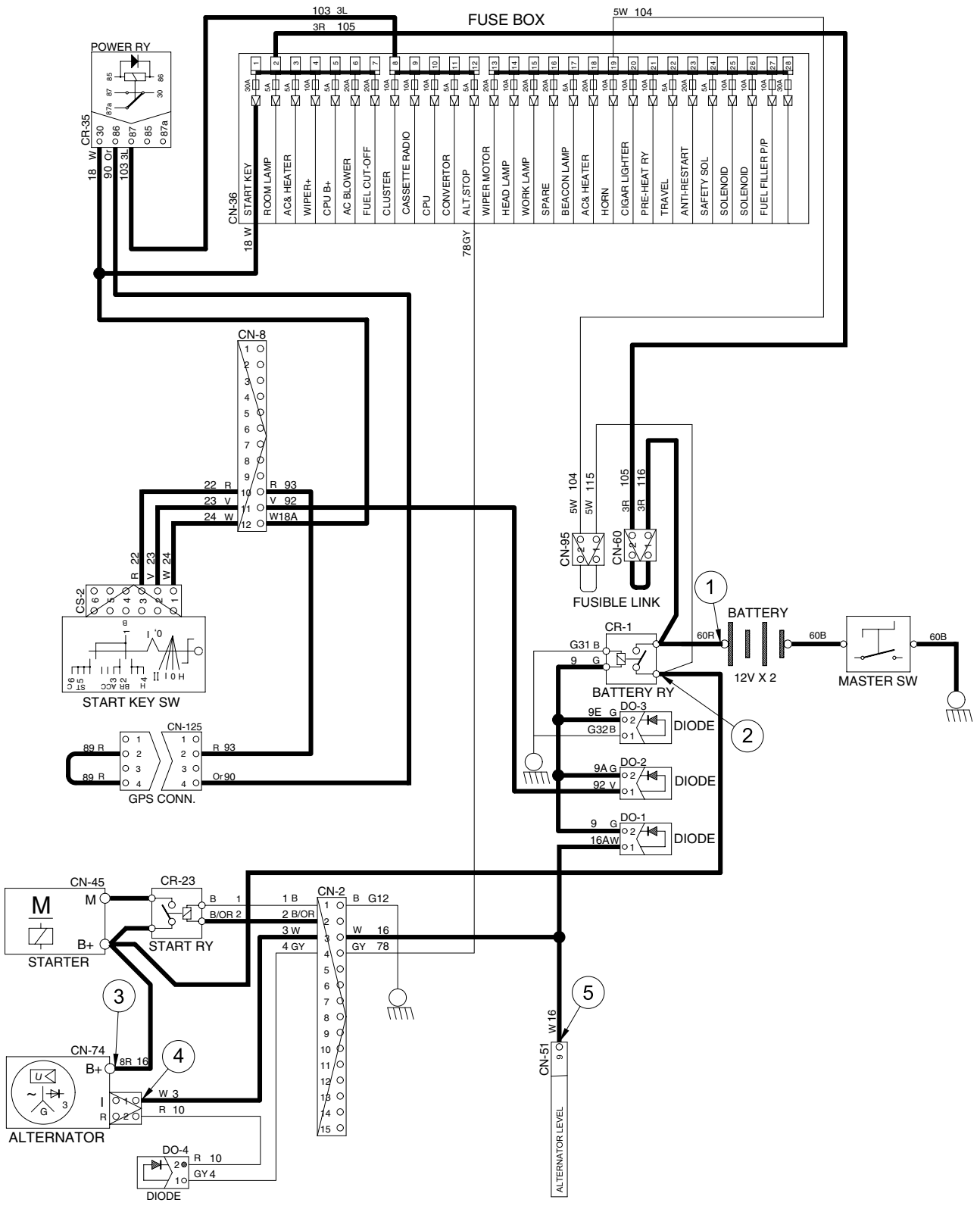

4. HEAD LAMP CIRCUIT

1) OPERATING FLOW

Fuse box (No.14) → I/conn [CN-5(15)] → Light switch[CS-21(1)]

※ When lamp switch ON

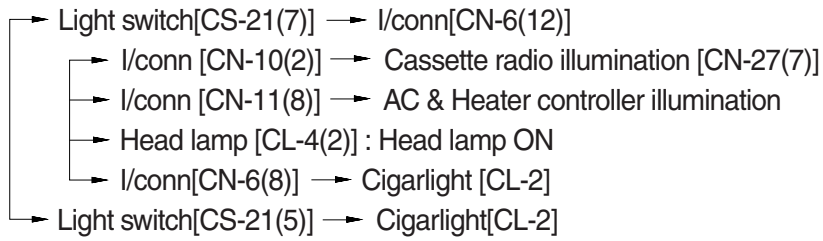

2) CHECK POINT

Engine	Key switch	Check point	Voltage
STOP	ON	① - GND (Fuse box) ② - GND (Switch power input) ③ - GND (Switch power output)	20~25V

※ GND : Ground

5. WORK LAMP CIRCUIT

1) OPERATING FLOW

Fuse box (No.15) → I/conn [CN-5(14)] → Light switch[CS-21(4)]

※ When work lamp switch ON

Work lamp switch ON [CS-21(2)] → I/conn [CN-5(2)] → Work lamp relay[CR-3(3)→(4)] →
I/conn[CN-12(1)] → Work lamp ON [CL-5(2), CL-6(2)]

2) CHECK POINT

Engine	Key switch	Check point	Voltage
STOP	ON	① - GND (Fuse box) ② - GND (Light switch input) ③ - GND (Light switch output) ④ - GND (Work lamp)	20~25V

※ GND : Ground

WORK LAMP CIRCUIT

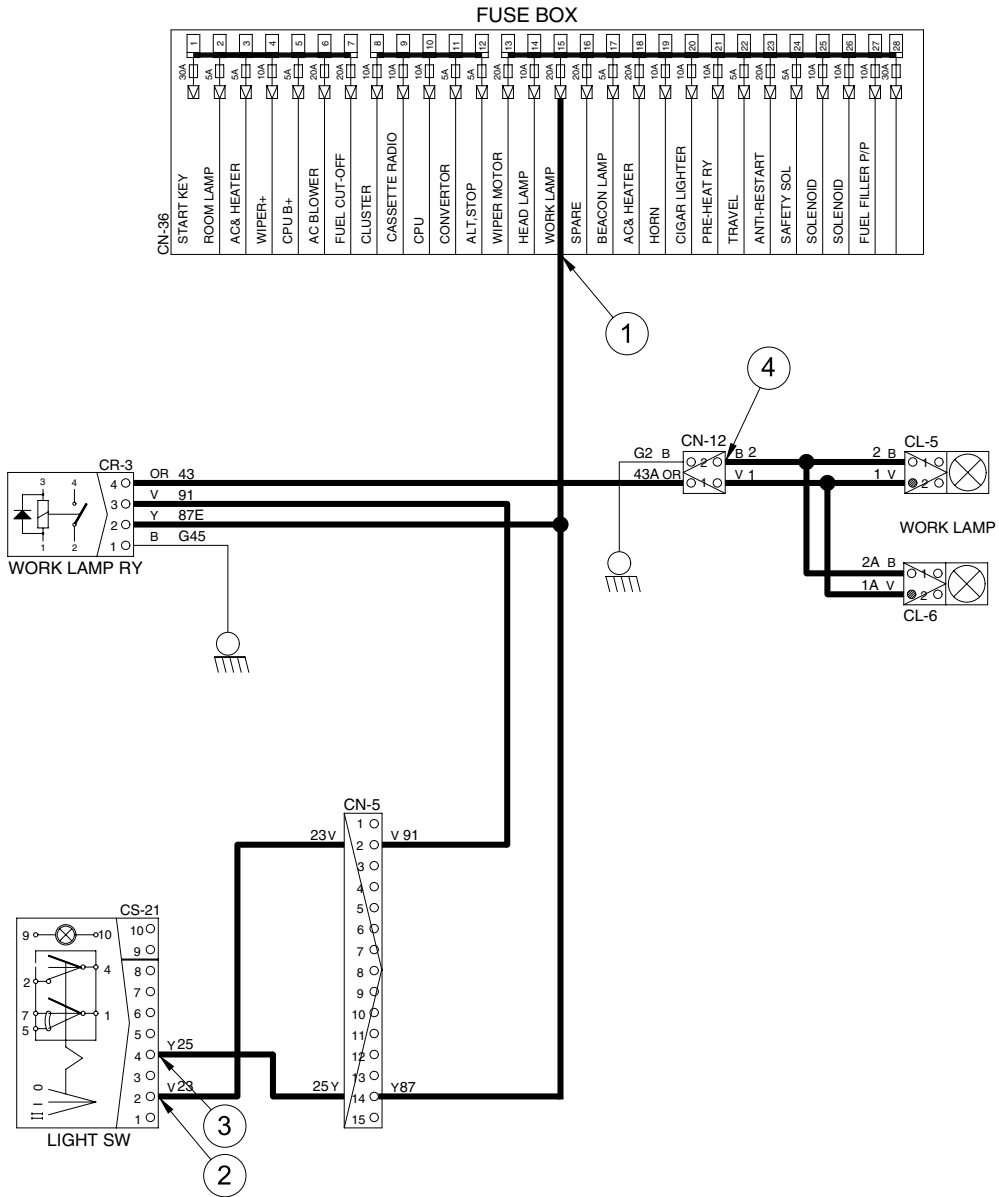

11074EL08

6. CAB LAMP CIRCUIT

1) OPERATING FLOW

Fuse box (No.15) → I/conn [CN-5(14)] → Light switch[CS-21(4)]

※ When Lamp switch ON

Lamp switch ON [CS-21(2)] → I/conn [CN-5(2)] → Work lamp relay[CR-3(3)→(4)] →
I/conn [CN-10(11)] → Cab light ON [CL-8(2), CL-9(2)]

2) CHECK POINT

Engine	Start switch	Check point	Voltage
STOP	ON	① - GND (Fuse box) ② - GND (Light switch input) ③ - GND (Light switch output) ④ - GND (Cab lamp)	20 ~ 25V

※ GND : Ground

CAB LAMP CIRCUIT

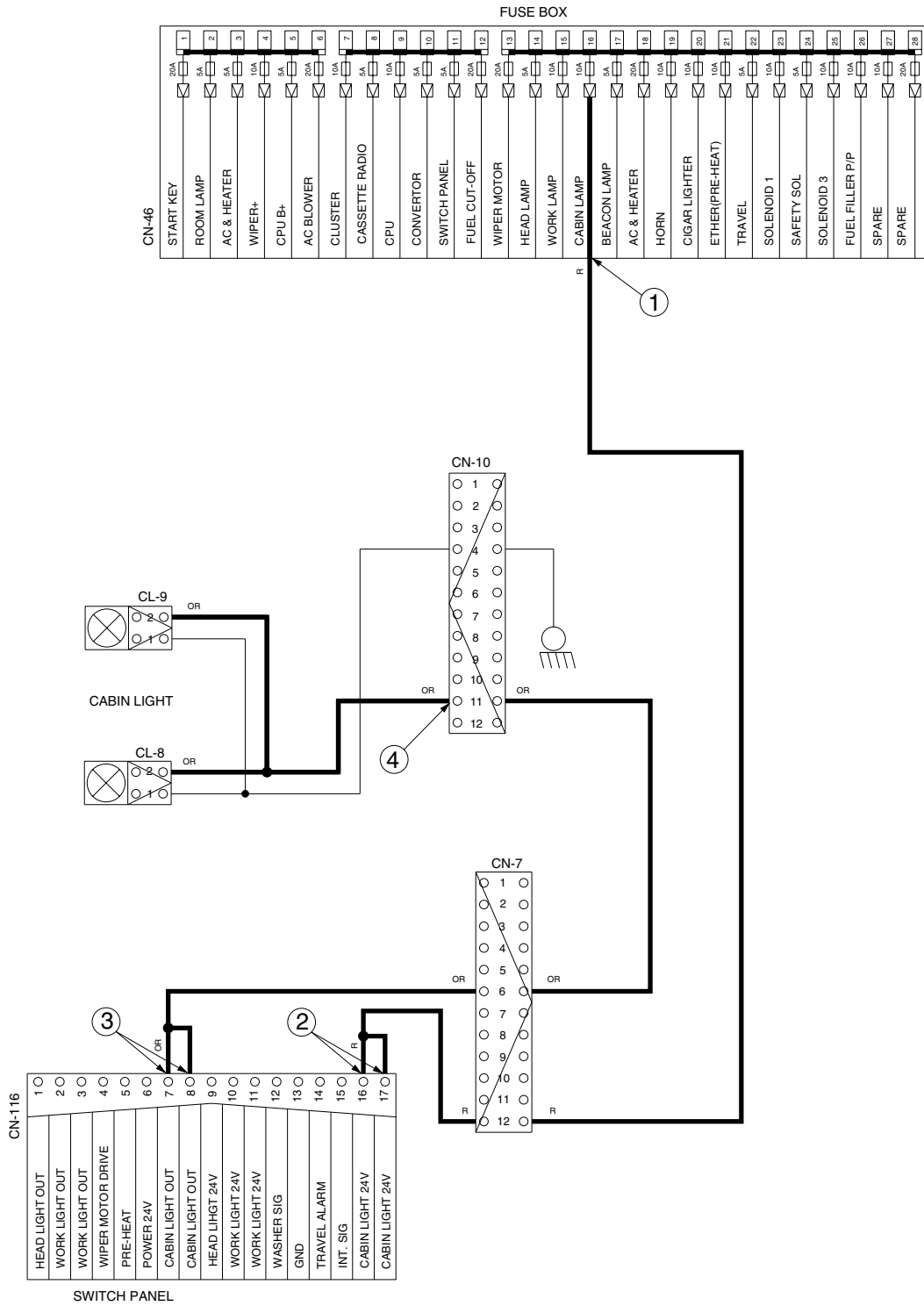

7. BEACON LAMP CIRCUIT

1) OPERATING FLOW

Fuse box (No.16) → I/conn [CN-8(3)] → Beacon lamp switch [CS-23(6)]

※ When lamp switch ON

Beacon lamp switch ON [CS-23(2)] → Switch Indicator lamp ON [CS-23(9)]
→ I/conn [CN-8(4)] → I/conn [CN-10(10)]
→ Beacon lamp ON [CL-7]

2) CHECK POINT

Engine	Start switch	Check point	Voltage
STOP	ON	① - GND(Fuse box) ② - GND(Switch power input) ③ - GND(Switch power output) ④ - GND(Beacon lamp)	20~25V

※ GND : Ground

BEACON LAMP CIRCUIT

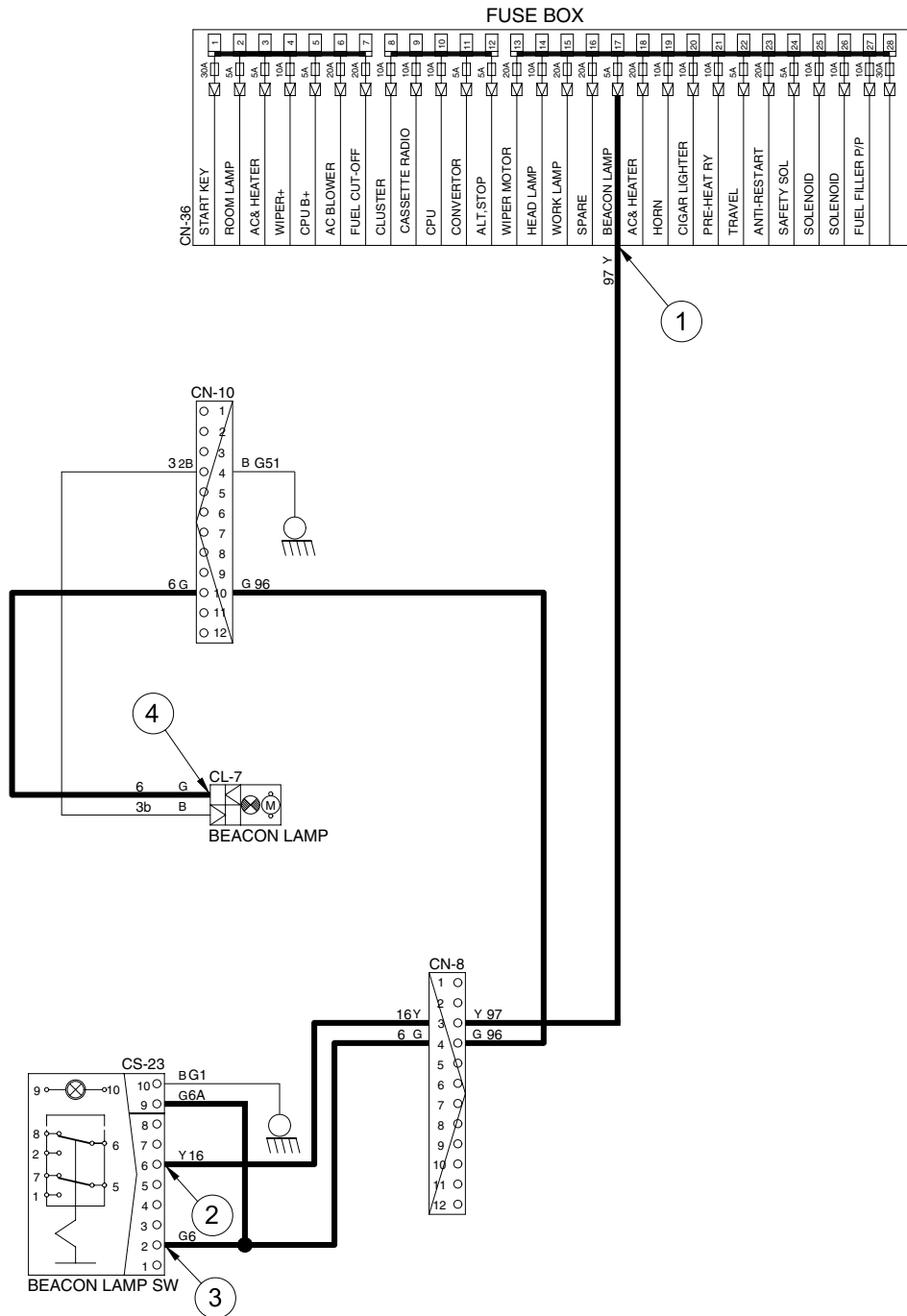

8. WIPER AND WASHER CIRCUIT

1) OPERATING FLOW

(1) Key switch ON

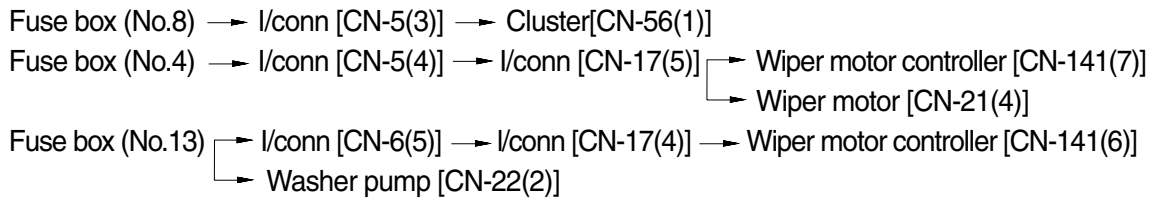

(2) Wiper switch ON(Intermittent)

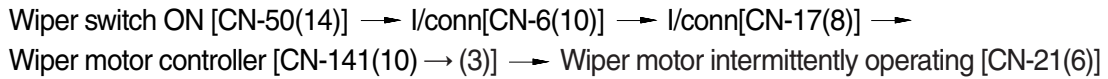

(3) Wiper switch ON

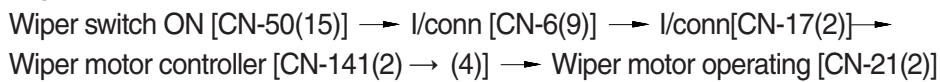

(4) Washer switch ON

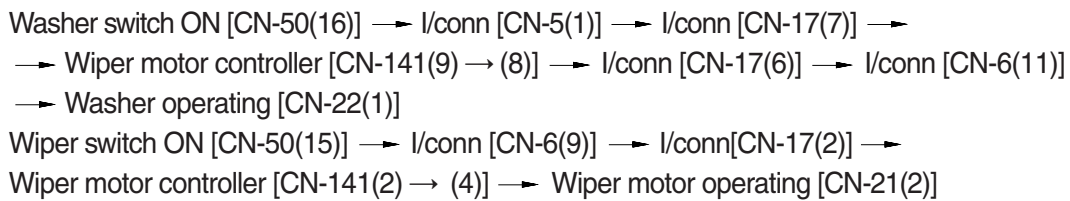

(5) Auto parking(When switch OFF)

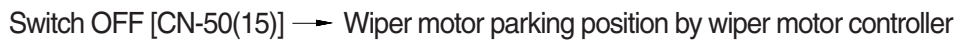

2) CHECK POINT

Engine	Start switch	Check point	Voltage
STOP	ON	① - GND(Fuse box)	24V
		② - GND(Switch power input)	
		③ - GND(Switch power output)	0~5V
		④ - GND(Wiper Power input)	
		⑤ - GND(Wiper power output)	24V
		⑥ - GND(Wiper motor)	0 or 24V

※ GND : Ground

WIPER AND WASHER CIRCUIT

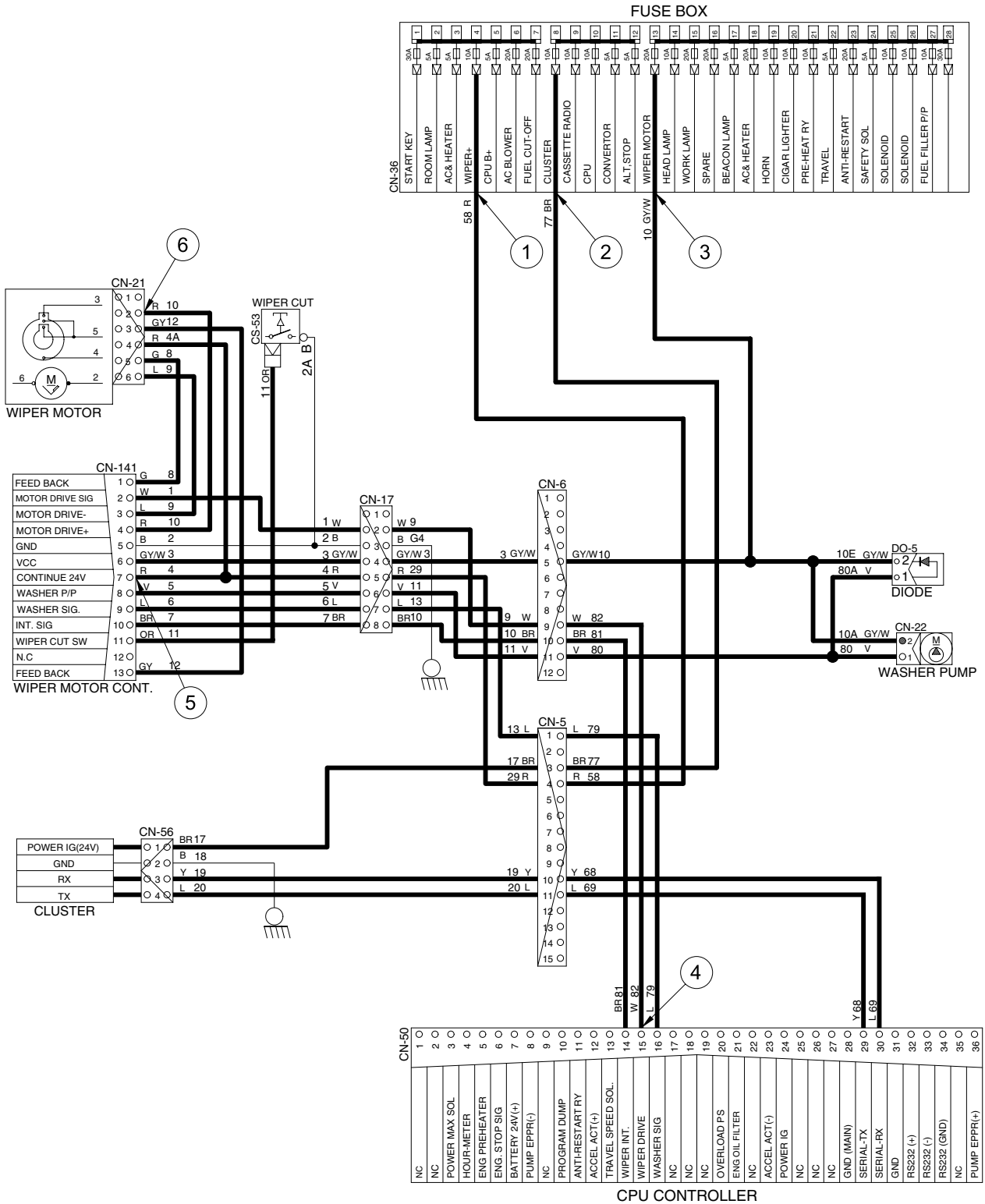

CONTROLLER CIRCUIT

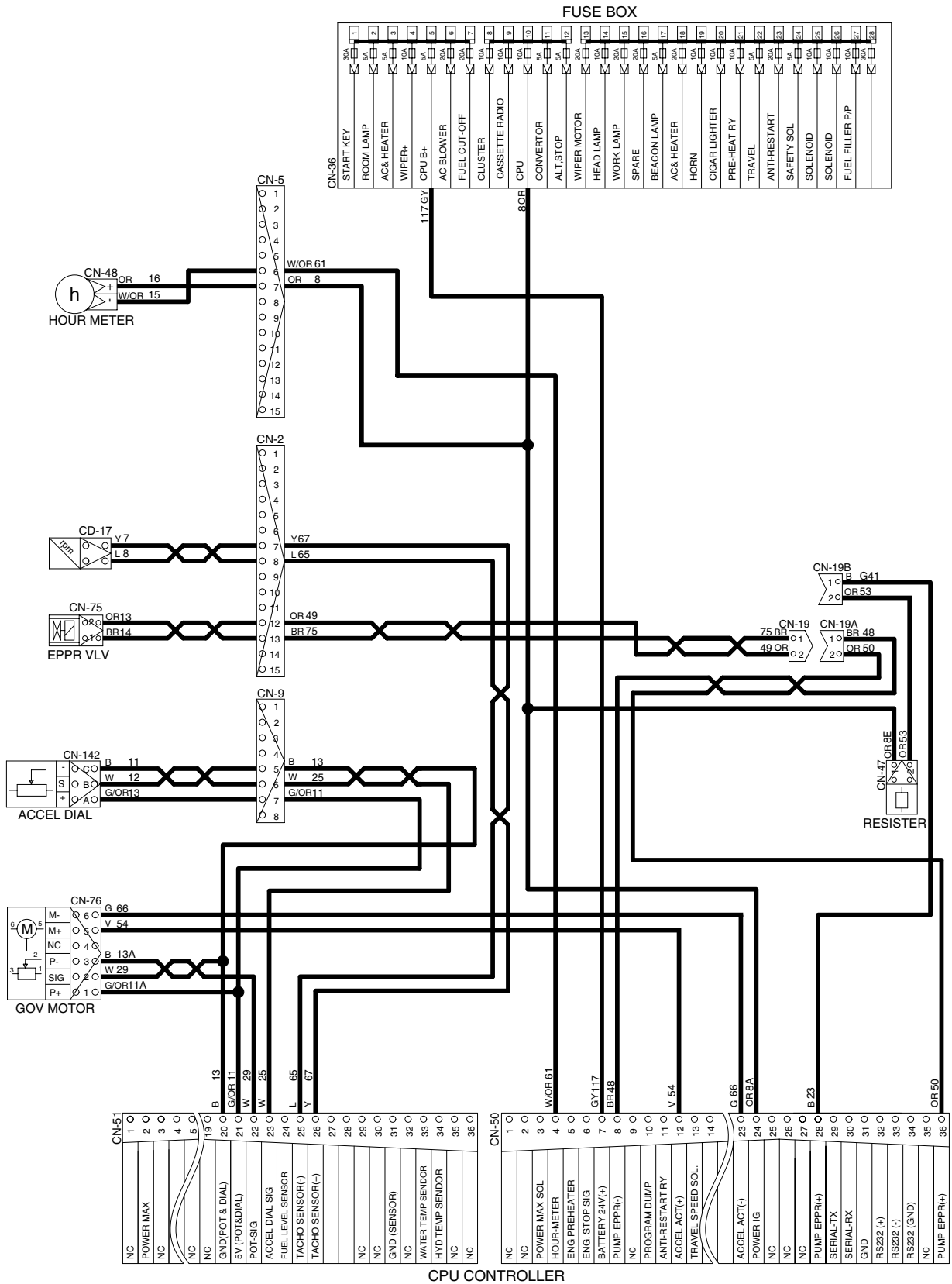

MONITORING CIRCUIT

