

Special Instruction

i06946711

Customer Assembly Requirements for 1206F-E70TA, 1206F-E70TTA, 1204F-E44TA, 1204F-E44TTA, and 854F-E34T Engines

Engine

1204F-E44TAA (MT; MU)

854F-E34T (JS; JT)

Industrial Engine

1206F-E70TA (BM; BN)

Table of Contents

Introduction	2
Engine Air Cleaner for 1206F-E70TA, 1206F-E70TTA, 1204F-E44TA, 1204F-E44TTA Engines	3
Air Temperature Sensor for 1206F-E70TA, 1206F-E70TTA, 1204F-E44TA, 1204F-E44TTA Engines	3
Fan for 1206F-E70TA, 1206F-E70TTA, 1204F-E44TA, 1204F-E44TTA Engines	4
Flexible Exhaust Pipe for 1206F-E70TA, and 1206F-E70TTA Engines	4
Flexible Exhaust Pipe for 1204F-E44TA, 1204F-E44TTA Engines	6
Installation of the Clean Emissions Module (CEM) for 1206F-E70TA, and 1206F-E70TTA Engines	8
Installation of the Clean Emissions Module (CEM) for 1204F-E44TA, 1204F-E44TTA Engines	9
Clean Emissions Module (CEM) (DOC and SCR)	9
Clean Emissions Module (CEM) (DOC, DPF, and SCR)	9

Diesel Exhaust Fluid (DEF) Dosing Control System on 1206F-E70TA, and 1206F-E70TTA Engines	10
Pump Electronics Tank Unit (PETU)	10
DEF Tank Mounting and Installation	10
Type 1 DEF Tank	10
Type 2 DEF Tank	11
DEF Tank with separate Pump Electronic Unit (PEU)	12
Type 3 DEF Tank	13
Diesel Exhaust Fluid Lines	14
Coolant Connections	15
Diesel Exhaust Fluid (DEF) Dosing Control System on 1204F-E44TA, 1204F-E44TTA Engines	16
Pump Electronics Unit (PEU)	16
DEF Tank Mounting and Installation	17
Type 1 DEF Tank	17
Type 2 DEF Tank	18
Diesel Exhaust Fluid Lines	18
Coolant Diverter Valve	21
Coolant Connections	21
Fuel Cooler for 1206F-E70TA, and 1206F-E70TTA, 1204F-E44TA, 1204F-E44TTA Engines	23
Fuel Filter (In-Line) for 1206F-E70TA, and 1206F-E70TTA, 1204F-E44TA, 1204F-E44TTA Engines	23
Fuel Priming Pump (Electric Fuel Lift Pump (EFLP)) for 1206F-E70TA, and 1206F-E70TTA, 1204F-E44TA, 1204F-E44TTA Engines	23
Water Separator and Fuel Filter (Primary) for 1206F-E70TA, and 1206F-E70TTA, 1204F-E44TA, 1204F-E44TTA Engines	24
Remote Engine Oil Filter Base for 1204F-E44TA, 1204F-E44TTA Engines	25
Soot Sensor for 1206F-E70TA, and 1206F-E70TTA Engines	27
Soot Sensor for 1204F-E44TA, and 1204F-E44TTA Engines (If equipped)	27
Nitrogen Oxide Sensor for 1206F-E70TA, and 1206F-E70TTA Engines	28
Nitrogen Oxide (NOx) Sensor for 1204F-E44TA, and 1204F-E44TTA Engines	30
Ammonia Sensor for 1204F-E70TA, and 1204F-E70TTA Engines (If equipped)	31

Product Lifting	32
Product Lifting for 1206F-E70TA, and 1206F-E70TTA Engines	32
Engine and Clean Emission Module (CEM)	32
Clean Emission Module (CEM) Only	33
Pump Electronics Tank Unit (PETU) Only	33
Engine Only	34
Product Lifting for 1204F-E44TA, and 1204F-E44TTA Engines	34
Engine and Clean Emission Module (CEM)	34
Engine Only	35
Clean Emission Module (CEM) of DOC and SCR	36
Clean Emission Module (CEM) of DOC, DPF, and SCR	37
Product Lifting for 854F-E34T Engines	38
Engine Air Cleaner for 854F-E34T Engines	38
Air Temperature Sensor for 854F-E34T Engines	39
Installation of the Fan for 854F-E34T Engines	39
Installation of the Fan for 854F-E34T Engines (Engines without a Fan Drive)	39
Flexible Exhaust Pipe for 854F-E34T Engines	40
Water Separator and Fuel Filter (Primary) for 854F-E34T Engines	41
Electronic Control Module (ECM) and Wiring Harness Installation on 854F-E34T Engines	41
Flywheel for Certain 854F-E34T Engines	42
Alignment of the Flywheel Face	42
Flywheel Runout	43
Alignment of the Flywheel Face	43
Flywheel Runout	44
Electric Starting Motor on Certain 854F-E34T Engines	44
Installation of Alternator and Fan Belts on 854F-E34T Engines	45
Air Compressor Bracket Installation for 854F-E34T Engines	46
Power Take-Off Drive for 854F-E34T Engines	46
Installation of Driven Equipment to the Power Take-Off Drive Without the Removal of the Power Take-Off Drive from the Engine	46
Installation of Driven Equipment to the Power Take-Off Drive With the Removal of the Power Take-Off Drive from the Engine	47
Oxygen Sensor for 854F-E34T Engines	49
Temperature Sensor (DPF) for 854F-E34T Engines	49
Differential Pressure Sensor for 854F-E34T Engines	50
Painting of the 854F-E34T Engine	50
Painting of the Main Engine Components	50
Electrostatic Painting of the Engine	50
Engine Labels for 854F-E34T Engines	51
Engine Lubricating Oil Recommendations	51
Coolant Recommendations	51

Glow Plug Control Unit for 854F-E34T Engines	51
Heater Connections for Operators Enclosure for 854F-E34T Engines	52
Heater Connection for Crankcase Breather for 854F-E34T Engines	52
Auxiliary Crankshaft Pulley for 854F-E34T Engines	52
Hydraulic Pump Drive Adaptor for 854F-E34T Engines	52

Introduction

The correct installation of emissions critical components is vital to comply with the relevant emissions legislation. In addition, the document highlights the key assembly characteristics of other components that are transported loose. The assembly of the loose components is carried out by a representative of the customer.

This Special Instruction is to be used in addition to the Service Manual. This document should be used as an assembly guide or a reference document when developing processes for production assembly facilities. Critical assembly characteristics such as tightening torques, component orientation, and assembly sequences must be followed to achieve the required product quality and emissions regulations.

The Service Manual consists of the following manuals.

- Operation and Maintenance Manual
- Disassembly and Assembly
- Troubleshooting
- Systems Operation Testing and Adjusting
- Specifications

Customers are permitted to paint the engine as received or as part of a power train sub assembly. These engines are supplied in gray primer.

The customer must not paint the aftertreatment or exhaust systems, Electronic Control Module (ECM), starting motor, alternator, belts, or the glow plug control unit. The customer must not paint any filters and filter canisters. The canisters include fuel, air, oil, crankcase breather, or DEF.

The customer must develop suitable plugs and masks to a standard equivalent to the engine assembly plant.

The customer must prevent water ingress into the engine by maintaining a plugging standard equivalent to the engine assembly plant.

Engine Air Cleaner for 1206F-E70TA, 1206F-E70TTA, 1204F-E44TA, 1204F-E44TTA Engines

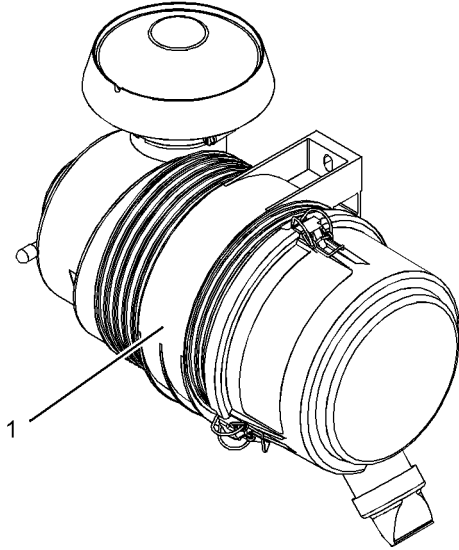

Illustration 1 g03179402
Typical example

The engine air cleaner (1) can be supplied as a loose assembly. The engine air cleaner should be mounted horizontally. The dust exhaust port must be at the lowest point and positioned in a direction that is down.

Note: Do not paint the dust exhaust port. Solvents and chemicals will shorten the usable life of the exhaust port.

Note: There are several variations of engine air cleaner.

Select the appropriate sized fasteners for the relevant air cleaner. Bolts should have a flanged head or be installed with a washer under the bolt head.

Standard duty air cleaner

Tighten the M10 bolts to the following torque.
..... $38.5 \pm 5.5 \text{ N}\cdot\text{m}$ ($28.4 \pm 4.1 \text{ lb ft}$)

Heavy-duty air cleaner

Tighten the M8 bolts to the following torque.
..... $15 \pm 3 \text{ N}\cdot\text{m}$ ($133 \pm 27 \text{ lb in}$)

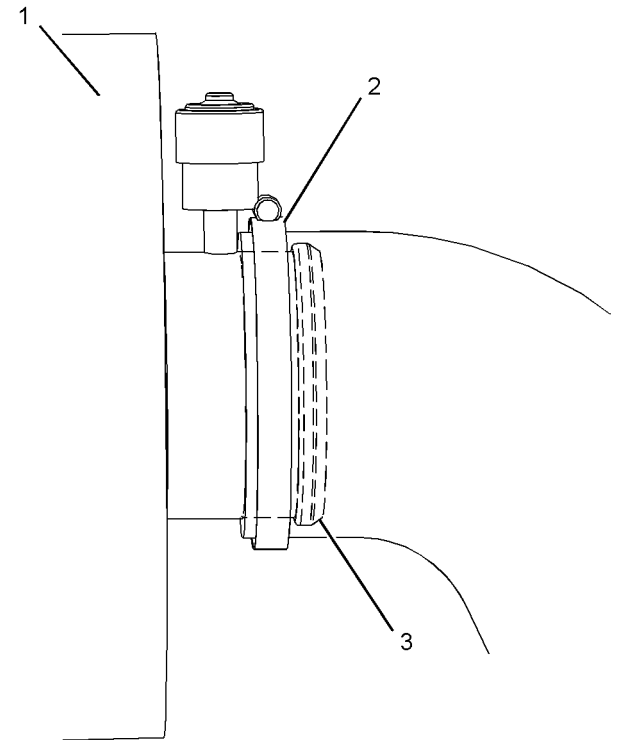

Illustration 2 g03415816
Typical example

The position of the clamp (2) in relation to pipe or component bead (3) is crucial. Ensure that clamp (2) is installed on the correct side of the pipe or component beads (3).

Air Temperature Sensor for 1206F-E70TA, 1206F-E70TTA, 1204F-E44TA, 1204F-E44TTA Engines

The air temperature sensor can be supplied loose.

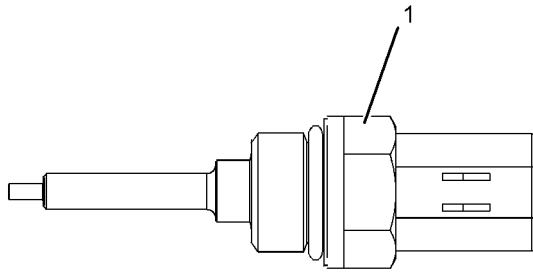

Illustration 3

g03178776

Typical example

Install the sensor (1). Tighten the sensor to a torque of $20 \pm 3 \text{ N}\cdot\text{m}$ ($177 \pm 27 \text{ lb in}$).

Note: Ensure that the O-ring is correctly installed to the sensor. Do not lubricate the O-ring seal.

Fan for 1206F-E70TA, 1206F-E70TTA, 1204F-E44TA, 1204F-E44TTA Engines

The fan can be supplied loose.

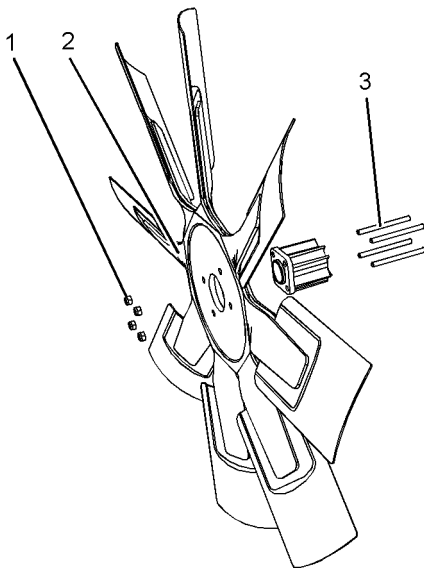

Illustration 4

g03178780

Typical example

1. Remove locking nuts (1) from studs (3).

2. If studs (3) have not been previously removed from fan drive. Check for the correct installation of the studs to the fan drive. Tighten studs (3) to a torque of $11 \pm 3 \text{ N}\cdot\text{m}$ ($97 \pm 27 \text{ lb in}$).

3. Install fan (2) to studs (3).

Note: Ensure that the label "Radiator Side" is visible once the fan is installed from the front of the engine.

4. Inspect the condition of locking nuts (1). If necessary, replace the locking nuts. Install locking nuts (1). Tighten locking nuts to a torque of $22 \pm 5.5 \text{ N}\cdot\text{m}$ ($195 \pm 49 \text{ lb in}$).

Flexible Exhaust Pipe for 1206F-E70TA, and 1206F-E70TTA Engines

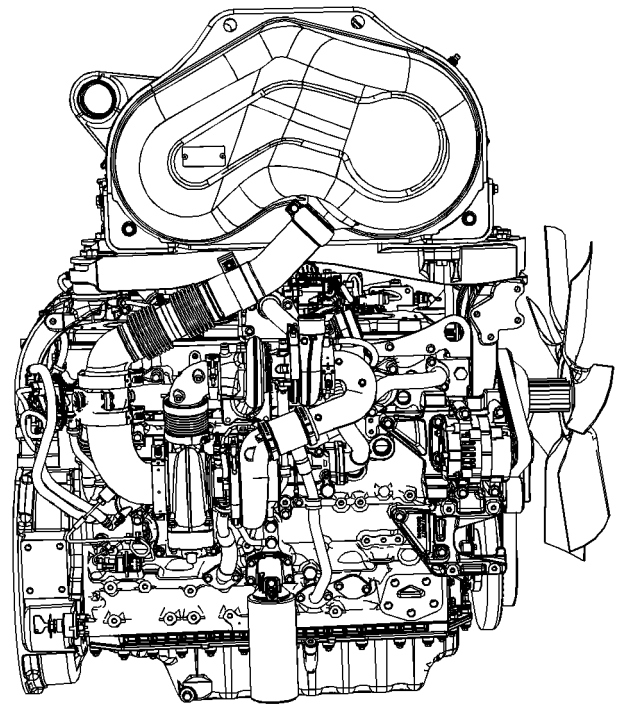

Illustration 5

g03393961

Typical example

The flexible exhaust pipe is a series of separate components that connect the turbocharger exhaust to the inlet of the Clean Emissions Module (CEM). The flexible exhaust pipe has been designed to account for some lateral or axial misalignment due to component tolerances. Refer to illustration 5 for an example of an installed flexible exhaust pipe.

There are variations of the flexible exhaust pipe. All flexible exhaust pipes will consist of some or multiple numbers of the following components.

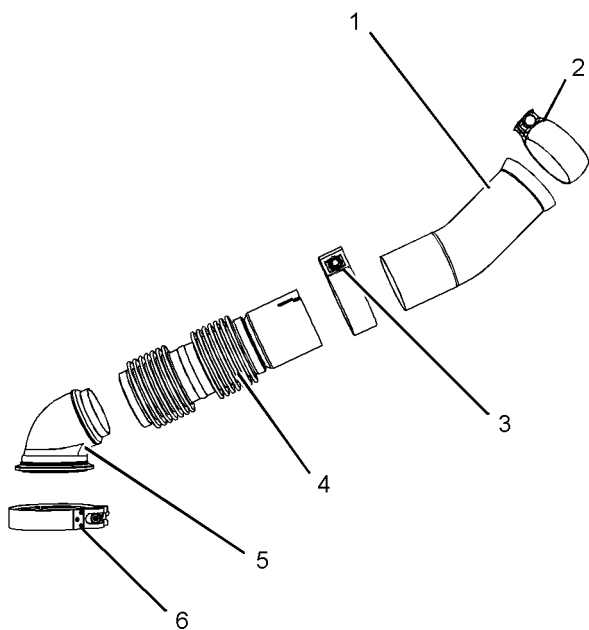

Illustration 6

g03393969

Typical example

- (1) Tube assembly
- (2) Ball clamp
- (3) Clamp
- (4) Bellows
- (5) Elbow
- (6) V-band clamp

The bellows are supplied with a protective sleeve. The protective sleeve protects the bellows from damage when the bellows is transported and installed.

Note: Do not remove the protective sleeve until the installation of the flexible exhaust pipe is complete.

Do not to disrupt the bellows from the neutral position when the bellows is installed. All component tolerances must be absorbed by the clamps and the ball clamps.

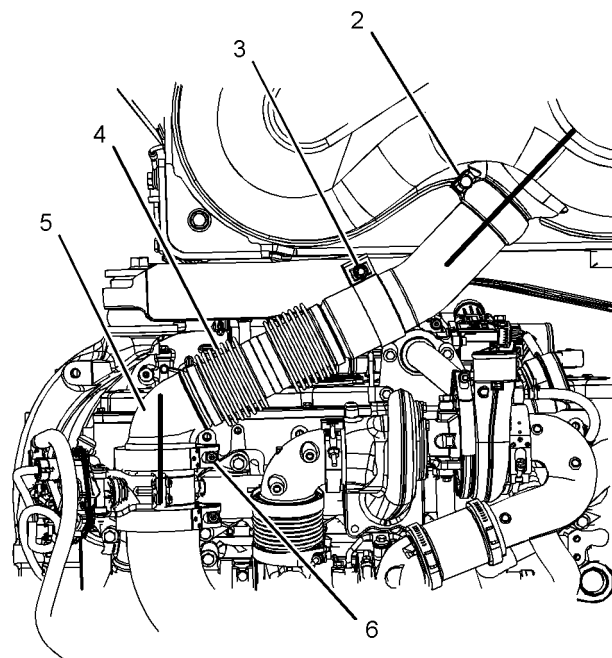

Illustration 7

g03393963

Typical example

1. Assemble the flexible exhaust pipe components.

Note: Ensure that the assembly of the flexible exhaust pipe is always supported.

2. Install ball clamp (2) to CEM. Tighten ball clamp (2) hand tight.
3. Install elbow (5) and V-band clamp (6) to exhaust back pressure valve. Tighten V-band clamp (6) hand tight.

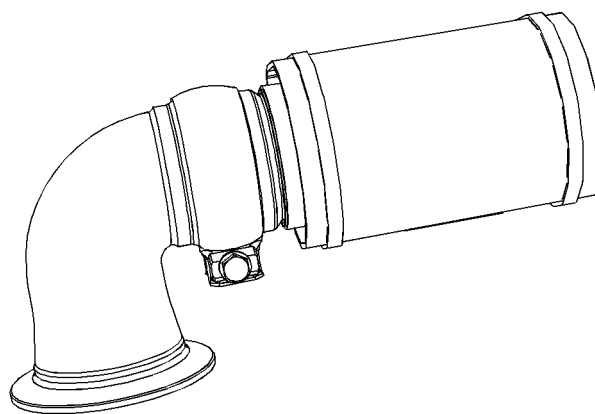

Illustration 8

g03181456

Typical example

Illustration 8 shows the clamp aligned correctly with an even space between the edges of the clamp.

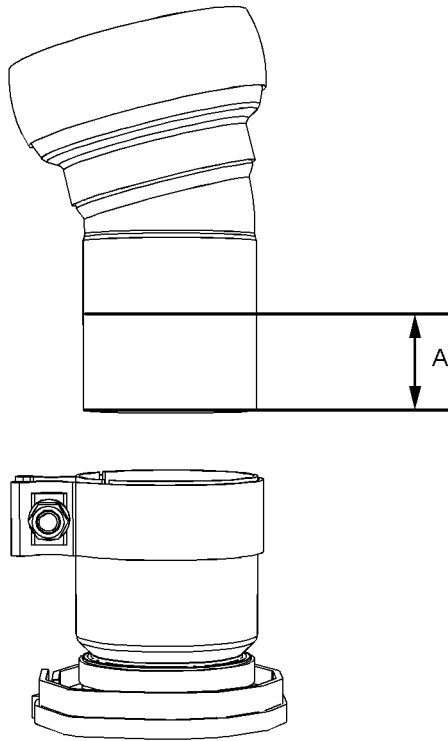

Illustration 9

g03181476

Typical example

Ensure that at least 40 mm (1.57 inch) (A) of the tube assembly is inserted into the clamp. A temporary mark can be made on the tube assembly before installation.

1. Check the spaces between the clamps and the associated components are even.
2. Tighten ball clamp (2) to a torque of $35 \pm 2 \text{ N}\cdot\text{m}$ ($26 \pm 1 \text{ lb ft}$).
3. Tighten clamp (3) to a torque of $55 \pm 8 \text{ N}\cdot\text{m}$ ($41 \pm 6 \text{ lb ft}$).
4. Tighten V-band clamp (6) to a torque of $12 \pm 1 \text{ N}\cdot\text{m}$ ($106 \pm 9 \text{ lb in}$).
5. Remove the protective sleeve.

Flexible Exhaust Pipe for 1204F-E44TA, 1204F-E44TTA Engines

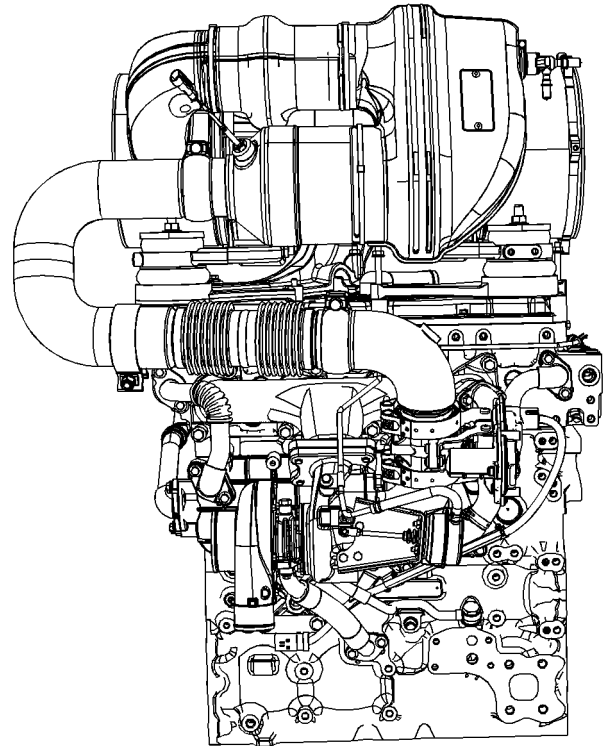

Illustration 10

g03693796

Typical example

The flexible exhaust pipe is a series of separate components that connect the turbocharger exhaust to the inlet of the Clean Emissions Module (CEM). The flexible exhaust pipe has been designed to account for some lateral or axial misalignment due to component tolerances. Refer to illustration 10 for an example of an installed flexible exhaust pipe.

There are variations of the flexible exhaust pipe. All flexible exhaust pipes will consist of some or multiple numbers of the following components.

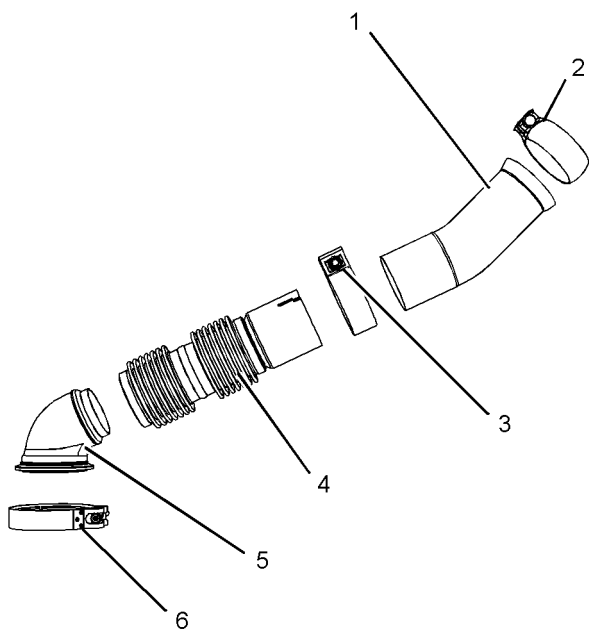

Illustration 11

g03393969

Typical example

- (1) Tube assembly
- (2) Ball clamp
- (3) Clamp
- (4) Bellows
- (5) Elbow
- (6) V-band clamp

The bellows are supplied with a protective sleeve. The protective sleeve protects the bellows from damage when the bellows is transported and installed.

Note: Do not remove the protective sleeve until the installation of the flexible exhaust pipe is complete.

Do not disturb the bellows from the neutral position when the bellows is installed. All component tolerances must be absorbed by the clamps and the ball clamps.

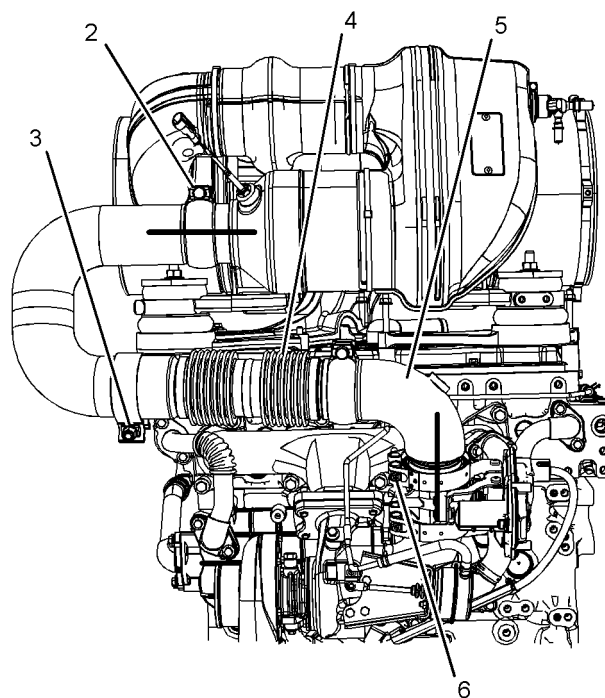

Illustration 12

g03693801

Typical example

1. Assemble the flexible exhaust pipe components.

Note: Ensure that the assembly of the flexible exhaust pipe is always supported.

2. Install ball clamp (2) to CEM. Tighten ball clamp (2) hand tight.
3. Install elbow (5) and V-band clamp (6) to exhaust back pressure valve. Tighten V-band clamp (6) hand tight.

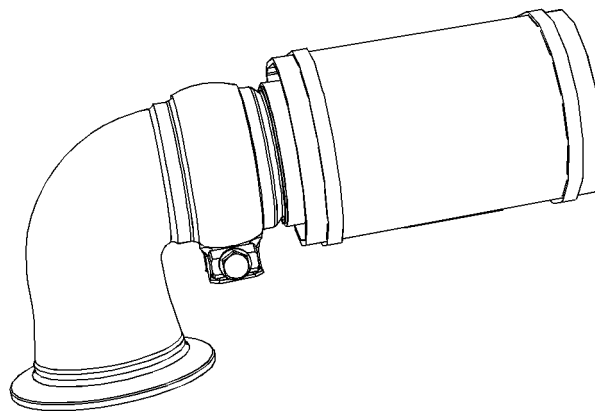

Illustration 13

g03181456

Typical example

Illustration 13 shows the clamp aligned correctly with an even space between the edges of the clamp.

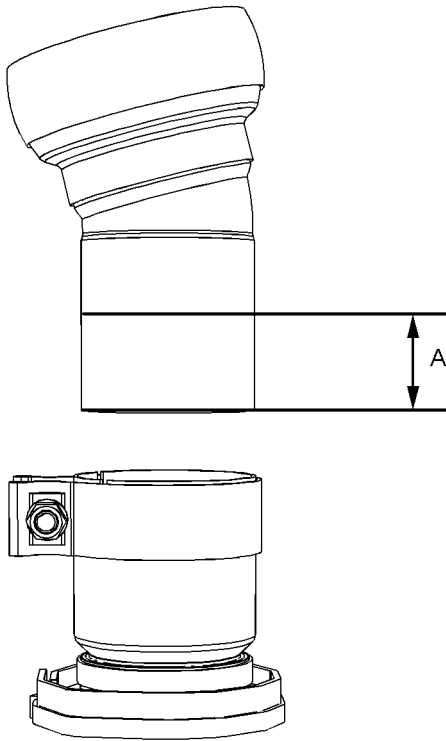

Illustration 14

g03181476

Typical example

Ensure that at least 40 mm (1.57 inch) (A) of the tube assembly is inserted into the clamp. A temporary mark can be made on the tube assembly before installation.

1. Check the spaces between the clamps and the associated components are even.
2. Tighten ball clamp (2) to a torque of 35 ± 2 N·m (26 ± 1 lb ft).
3. Tighten clamp (3) to a torque of 55 ± 8 N·m (41 ± 6 lb ft).
4. Tighten V-band clamp (6) to a torque of 12 ± 1 N·m (106 ± 9 lb in).
5. Remove the protective sleeve.

Installation of the Clean Emissions Module (CEM) for 1206F-E70TA, and 1206F-E70TTA Engines

NOTICE

Care must be taken when the Clean Emissions Module (CEM) is removed from the transportation crate.

After the Clean Emissions Module (CEM) is removed from the transportation crate, the CEM should be inspected. Inspect the CEM for damage.

Use a suitable lifting device to lift the CEM. Refer to "Clean Emission Module (CEM) Only" for the correct procedure to lift the CEM.

1. Install the CEM to the support bracket on the application. Ensure that the CEM and support bracket are correctly seated and aligned.
2. Install the bolts that secure the CEM to the application. Tighten the bolts to a torque of 190 N·m (140 lb ft).
3. Remove the caps from the electrical components. Connect harness assembly to the electrical connections on the CEM.

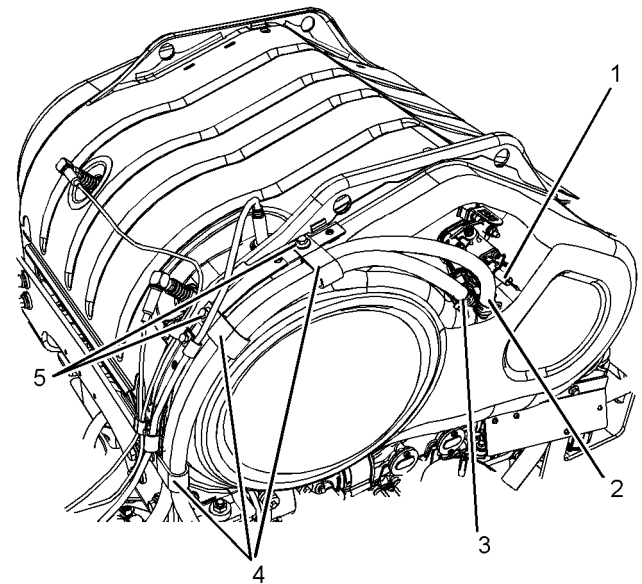

Illustration 15

g03430868

Typical example

4. Remove cap (1). Connect diesel exhaust fluid line to DEF injector. Remove caps from fluid connections on the DEF injector. If necessary, remove caps or plugs from coolant hose assembly (2) and coolant hose assembly (3).

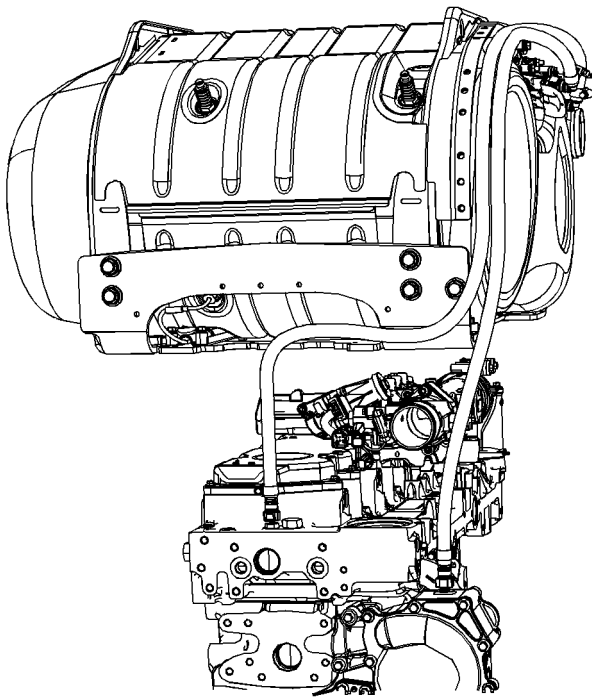

Illustration 16 g03408274

Typical example

5. Connect coolant hose assembly (2) and coolant hose assembly (3) to the relevant connections on the engine. Refer to illustration 16.
6. Position clips (4) to coolant hose assembly (2) and coolant hose assembly (3). Install bolts (5). Tighten bolts (5) to a torque of 12 N·m (106 lb in).
7. Install the exhaust system to the Clean Emissions Module (CEM).

Installation of the Clean Emissions Module (CEM) for 1204F-E44TA, 1204F-E44TTA Engines

NOTICE

Care must be taken when the Clean Emissions Module (CEM) is removed from the transportation crate.

After the Clean Emissions Module (CEM) is removed from the transportation crate, the CEM should be inspected. Inspect the CEM for damage.

Use a suitable lifting device to lift the CEM. Refer to "Product Lifting for 1204F-E44TA, and 1204F-E44TTA Engines" for the correct procedure.

Clean Emissions Module (CEM) (DOC and SCR)

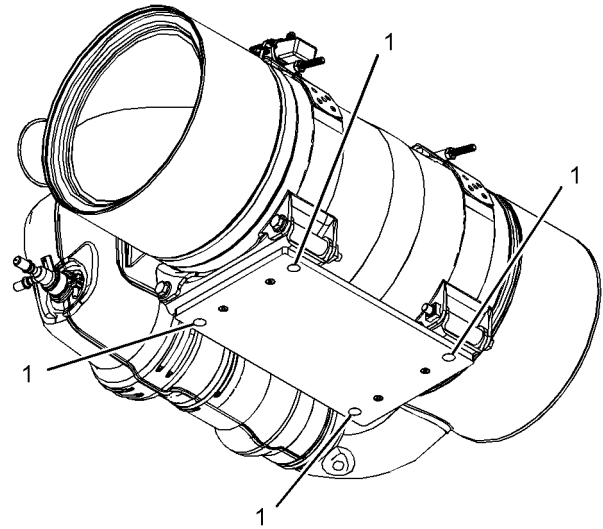

Illustration 17 g03707600

Typical example

To mount the CEM on the application there are four mounting points (1), two on each mounting bracket. Use suitable M10 x 1.75 weld nuts with 8.8 or 10.9 bolts.

Tighten the fasteners to the following torque.
 100 ± 20 N·m ((74 ± 15 lb ft))

Clean Emissions Module (CEM) (DOC, DPF, and SCR)

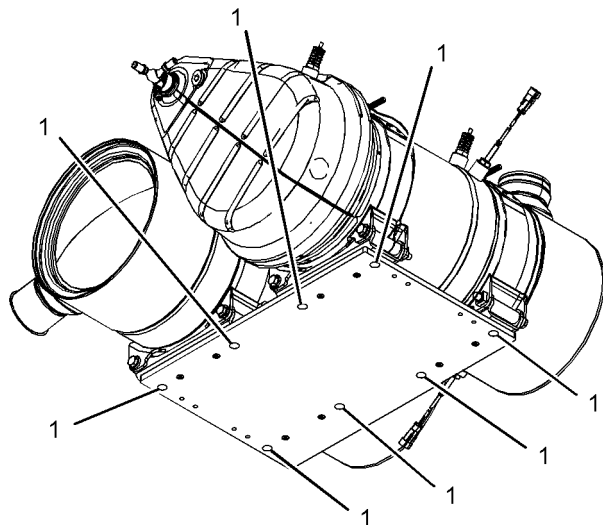

Illustration 18 g03728996

Typical example

To mount the CEM on the application there are eight mounting points (1), four on each mounting bracket. Use suitable M10 x 1.75 weld nuts with 8.8 or 10.9 bolts.

Tighten the fasteners to the following torque.
.....100 ± 20 N·m ((74 ± 15 lb ft))

Diesel Exhaust Fluid (DEF) Dosing Control System on 1206F-E70TA, and 1206F-E70TTA Engines

NOTICE

DEF system components are supplied with caps and plug over connection points. Do not remove the caps and plugs before final assembly to ensure that cleanliness is maintained.

DEF Cleanliness must be adhered to as outlined in ISO 22241.

Pump Electronics Tank Unit (PETU)

After the Pump Electronics Tank Unit (PETU) is removed from the transportation crate, the PETU should be inspected. Inspect the PETU for damage.

Use a suitable lifting device to lift the PETU. Refer to “Pump Electronics Tank Unit (PETU) Only” for the correct procedure to lift the PETU.

Install the PETU to the application. Ensure that the PETU is correctly seated and secure to the application.

DEF Tank Mounting and Installation

Type 1 DEF Tank

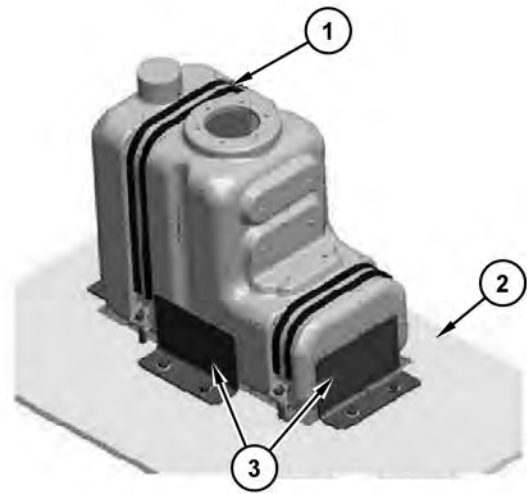

Illustration 19

g03413501

Typical example

- (1) Straps
- (2) Rubber mat
- (3) Stops

Type 1 DEF tanks must be installed to the application with the following criteria:

- The bottom of the DEF Tank must be fully supported by a structural platform. Full support is defined as a continuous material that is at least as large as the dimensions of the bottom of the tank. Structural is defined as being able to support full tank mass with application load without plastic deformation or failure.
- An anti-friction rubber mat under the bottom of the tank is required. If the installation uses DEF tank stops, the anti-friction device must also be between the stops and the DEF tank.
- Any metallic surfaces contacting the tank should be free of burrs, welds, foreign objects, and sharp edges.
- The tank strap must be located correctly. The DEF tank has strap grooves incorporated into the DEF tank to help keep the strap in place.
- A locked joint is a requirement and can be accomplished by using either a jam nut or lock nut.

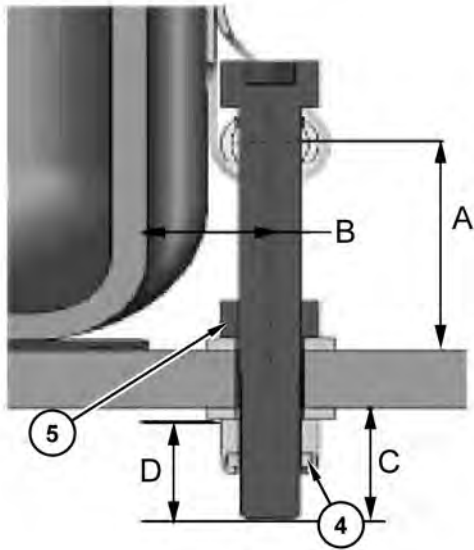

Illustration 20 g03413519

Typical example

- (4) Lock nut or weld nut
- (5) Jam nut
- (A) 45 mm (1.77 inch)
- (B) 20 mm (0.79 inch)
- (C) 24.25 mm (0.95 inch)
- (D) 21.75 mm (0.86 inch)

For DEF tanks that have been supplied by the engine manufacturer, following strap design is recommended:

- The strap size should have a width of 30 mm (1.18 inch) and a thickness of 1.5 mm (0.06 inch).
- The strap material should be stainless steel with rubber backing.
- The bolt size should be M10 by 1.5 with a bolt length of 90 mm (3.54 inch).

The strap pre-load should be a nominal 2.5 kN (562 lb). The maximum strap pre-load should be 4 kN (900 lb).

Tighten nuts to an initial torque
 $8 \pm 2 \text{ N}\cdot\text{m}$ ((71 \pm 18 lb in))

Tighten nuts to a final torque
 $11 \pm 1 \text{ N}\cdot\text{m}$ ((97 \pm 9 lb in))

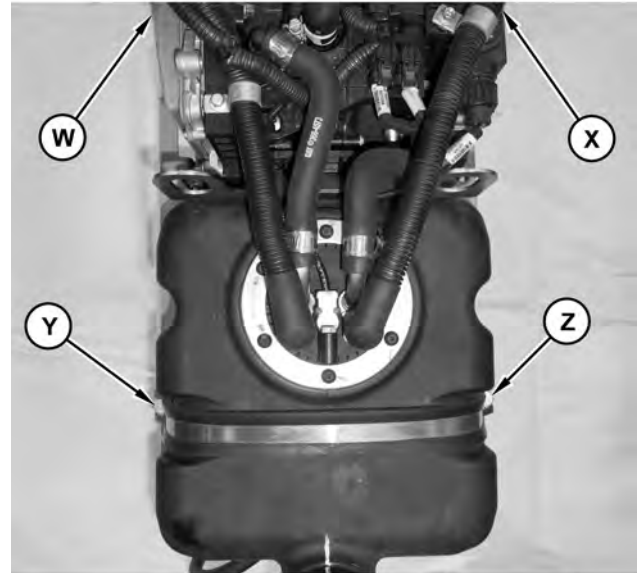

Illustration 21 g03376333

Typical example

Apply torque to the nuts in a (W),(X),(Y), (Z) sequence shown in Illustration 21.

Type 2 DEF Tank

Type 2 DEF tanks do not require the use of retaining straps or an anti-friction rubber mat.

Note: The bottom of the tank must be horizontal and fully supported by a structural platform.

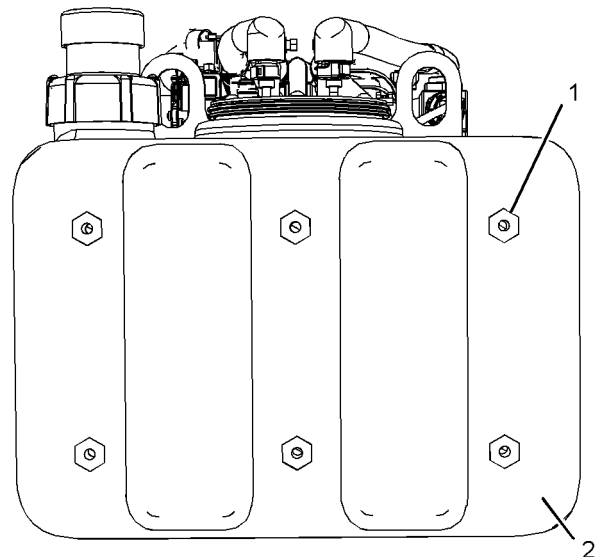

Illustration 22 g03412369

Typical example

Type 2 DEF tanks may be mounted by the use of the threaded inserts (1) on the rear of the DEF tank (2). All 6 threaded inserts must be used. Lock tight bolts are recommended. The bolt size should be M8 by 1.

Tighten the M8 bolts to the following torque.
..... 15 N·m ((11 lb ft))

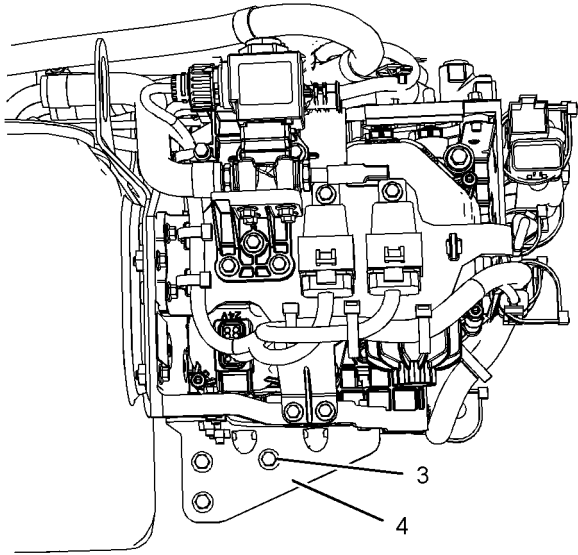

Illustration 23 g03412391
Typical example

The DEF pump assembly should be supported by a support bracket (4).

Tighten the fasteners (3) that secure the bracket (4) to the following torque.
..... 12 ± 3 N·m ((106 ± 27 lb in))

DEF Tank with separate Pump Electronic Unit (PEU)

Note: The DEF tank should be mounted to the application using the installation guidelines described in “Type 1 DEF Tank” or “Type 2 DEF Tank”.

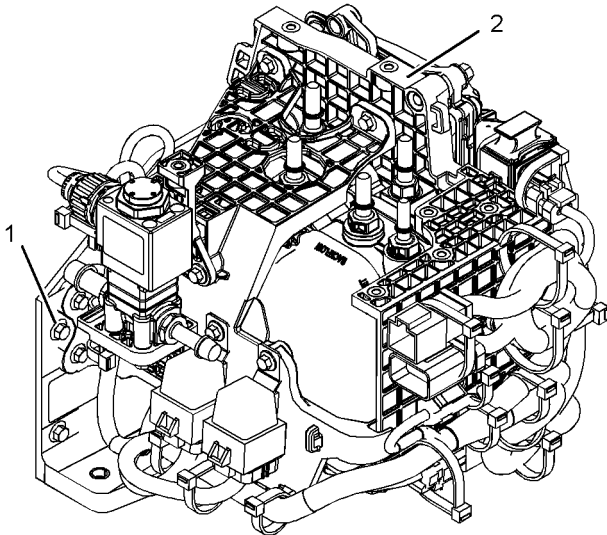

Illustration 24 g03418031
Typical example

Note: If the PEU is to be mounted on isolating mounts, a rigid metal bracket should be used. Contact the applications engineer for the engine manufacturer for more information.

M6 fasteners are recommended to secure PEU to the application.

Tighten the fasteners (1) that secure the PEU (2) to the following torque. . . . 12 ± 3 N·m ((106 ± 27 lb in))

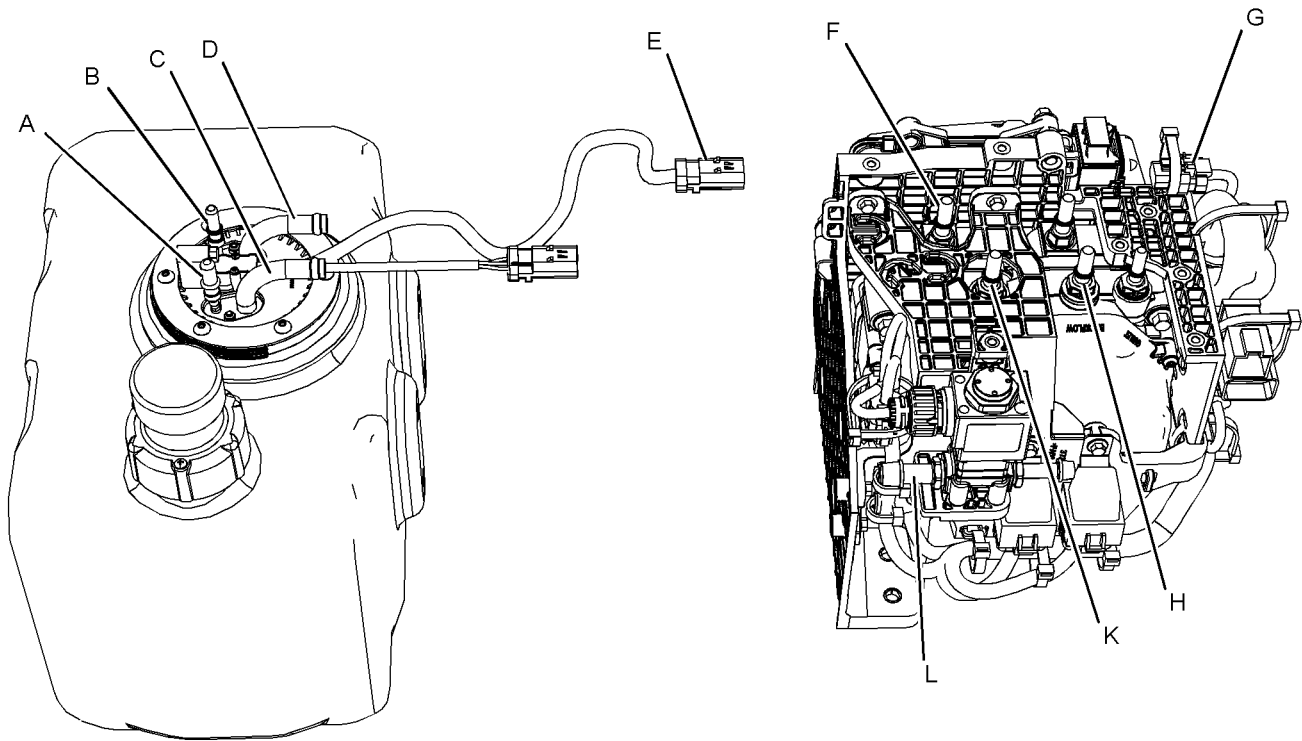

Illustration 25
Typical example

g03434836

Connect diesel exhaust fluid line to position (A) and position (K).

Connect diesel exhaust fluid line to position (B) and position (H).

Connect coolant hose assembly to position (C) and position (L).

Connect coolant hose assembly to position (D) and position (F).

Connect harness assembly (E) to electrical connection (G).

The specifications of the coolant hose assemblies are as follows.

The total length of the coolant hose assemblies (supply and return from DEF tank) must be less than 8 m (26 ft).

Internal diameter of connectors and coolant hose assemblies for the return to DEF tank
..... 15.9 mm ((0.62598 inch))

Internal diameter of connectors and coolant hose assemblies for the supply of the DEF tank
..... 9.5 mm ((0.37402 inch))

For the specifications of the diesel exhaust fluid lines, refer to "Diesel Exhaust Fluid Lines".

Type 3 DEF Tank

Type 3 DEF tanks are supplied by the Original Equipment Manufacturer (OEM). Type 3 DEF tanks are not supplied by the engine manufacturer.

The manifold (DEF) is supplied by the engine manufacturer.

The manifold (DEF) must be installed to the DEF tank as a sub assembly process.

Contact the applications engineer for the engine manufacturer if type 3 DEF tank and associated components are to be installed.

Diesel Exhaust Fluid Lines

The diesel exhaust fluid lines must be installed with the following conditions:

- Be routed as direct as possible with no excessive dips or sags
- Be routed to avoid abrasion and overheating
- Be adequately supported and not impose stress on the connector. The maximum clipping details are detailed in table 1 .
- Must fall within the length guidelines in table 2 .
- Allow for relative movement between the two components, DEF tank to DEF pump, DEF pump to DEF injector
- Do not exceed the minimum bend radii. Refer to table 3 for more information.

Table 1

Maximum clipping distances		
Connection to Clip	Clip to Clip	Electrical Cable
150 mm (6 inch)	150 to 300 mm (6 to 12 inch)	150 mm (6 inch)

Table 2

Diesel Exhaust Fluid Lines	Length	
	Min	Max
Suction (DEF tank to pump)	1000 mm (39.37 inch)	2000 mm (78.74 inch)
Pressure (pump to DEF injector)	1500 mm (59.055 inch)	4000 mm (157.48 inch)
Return (DEF injector to pump)	1500 mm (59.055 inch)	4500 mm (177 inch)

Table 3

Diesel exhaust fluid lines	51 mm (2.00787 inch)
Harness	10 mm (0.39370 inch)

Note: For a 12 VDC system, the total length of the three diesel exhaust fluid lines must not exceed 9500 mm (374 inch).

Note: For a 24 VDC system, the total length of the three diesel exhaust fluid lines must not exceed 10000 mm (394 inch).

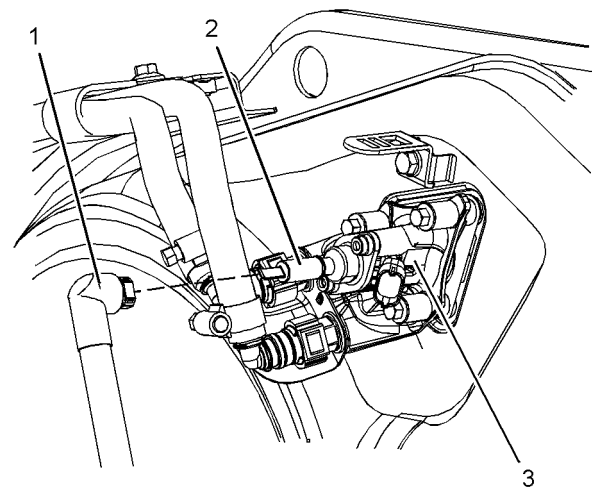

Illustration 26

g03418550

Typical example

1. Remove cap (2) from the connection on the DEF injector assembly (3). Remove plug from diesel exhaust fluid line. Connect diesel exhaust fluid line (1) to DEF injector assembly (3).

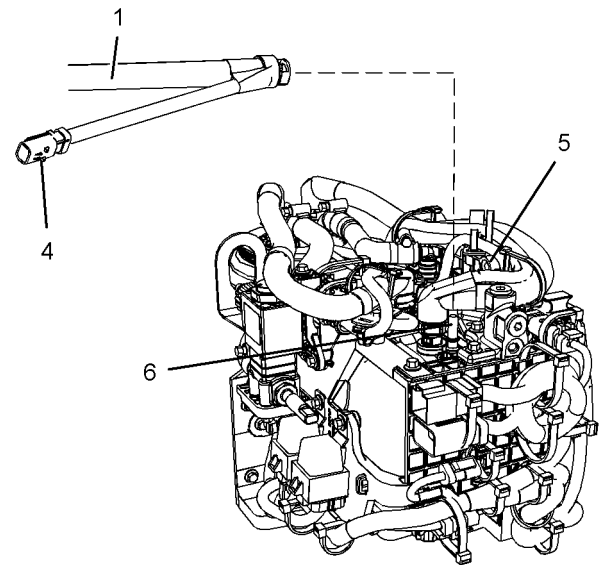

Illustration 27

g03418551

Typical example

2. Remove cap from connector (6) on the PETU (5).
3. Remove plug from diesel exhaust fluid line. Connect diesel exhaust fluid line (1) to connector (5).
4. Connect the electrical connection (4) for the diesel exhaust fluid line.

Coolant Connections

Coolant must be supplied from the engine to the manifold (DEF Heater) to heat the DEF tank. The coolant is supplied via the diverter valve controlled via the dosing control module.

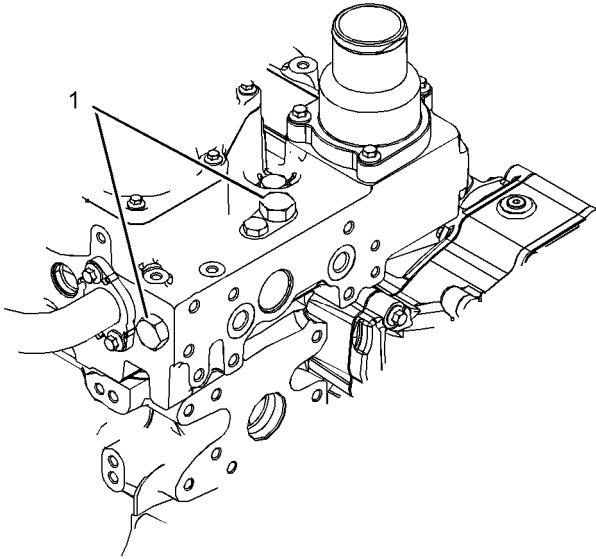

Illustration 28

g03413559

Typical example

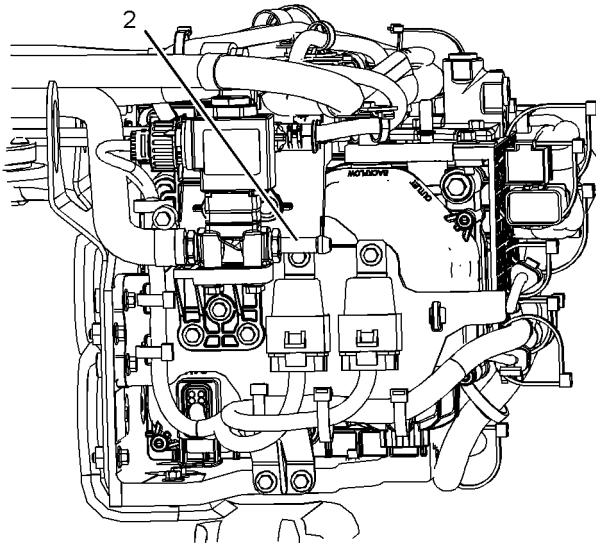

Illustration 29

g03413631

Typical example

Coolant is taken from the coolant outlet (1) on the engine to the inlet of the coolant diverter valve (2).

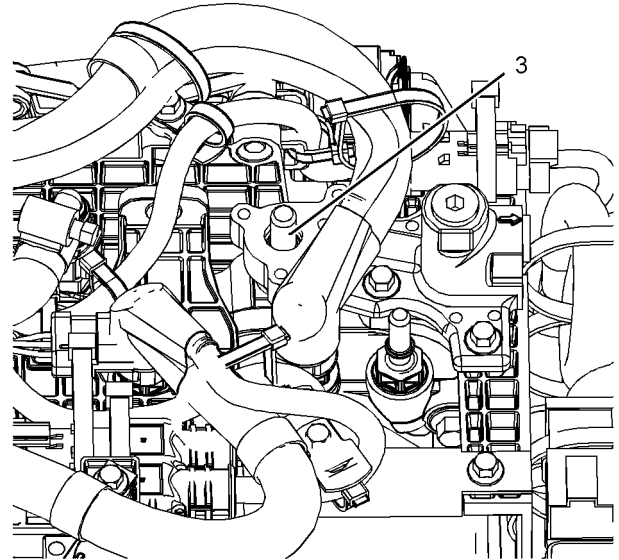

Illustration 30

g03413645

Typical example

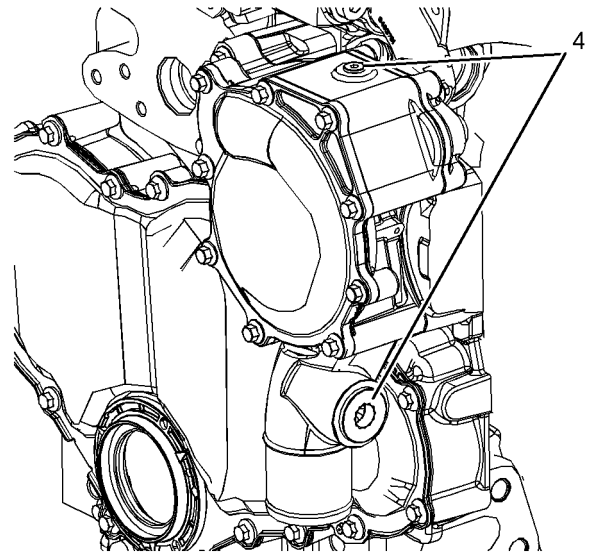

Illustration 31

g03413648

Typical example

Coolant is returned from the DEF pump back to the engine from connection (3) to the inlet connection on the engine (4).

Coolant is taken from the coolant outlet (1) on the engine to the inlet of the DEF injector.

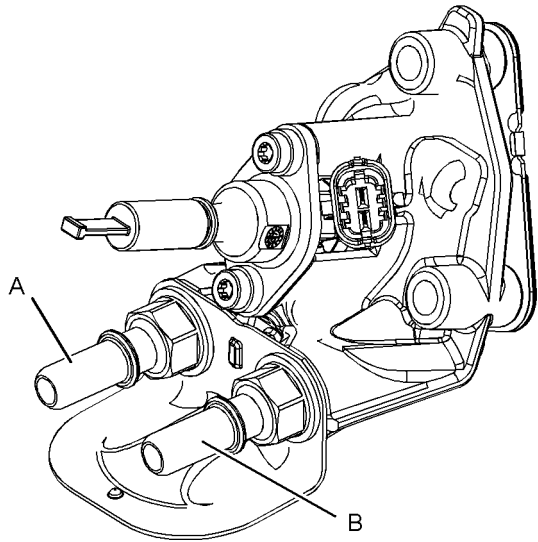

Illustration 32 g03413676

Typical example

- (A) Inlet coolant connection
- (B) Outlet coolant connection

Coolant is returned from the DEF injector to the inlet connection on the engine (4).

Refer to “Installation of the Clean Emissions Module (CEM) for 1206F-E70TA, and 1206F-E70TTA Engines” for an example of the installed coolant hoses.

Diesel Exhaust Fluid (DEF) Dosing Control System on 1204F-E44TA, 1204F-E44TTA Engines

NOTICE

DEF system components are supplied with caps and plug over connection points. Do not remove the caps and plugs before final assembly to ensure that cleanliness is maintained.

DEF Cleanliness must be adhered to as outlined in ISO 22241.

Pump Electronics Unit (PEU)

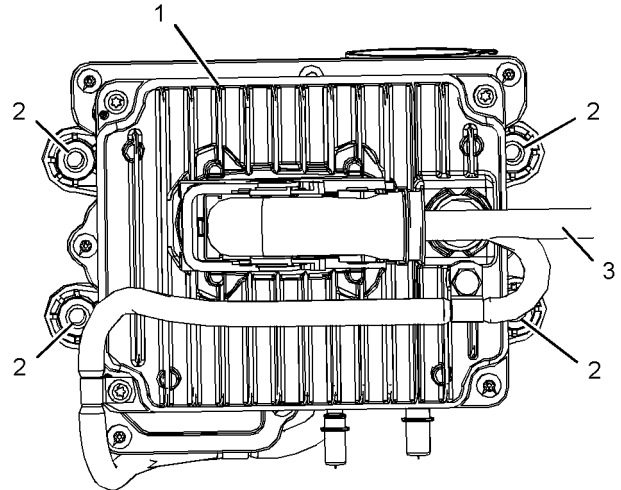

Illustration 33 g03707620

Typical example

After the Pump Electronics Unit (PEU) (1) is removed from the transportation crate, the PEU should be inspected. Inspect the PEU for damage.

The PEU must be installed to the application with the following criteria:

- The PEU must be mounted internally or externally via all four M8 mounting holes (2).
- The mounting face between the four points must be flat within a tolerance of 0 ± 0.5 mm (0 ± 0.01968 inch).
- The PEU must be installed vertically ± 5 degrees with the two DEF connections at the bottom and the filter at the top. This orientation ensures injection and purge functionality.

Tighten the M8 fasteners to the following torque.
 16 ± 1 N·m (142 ± 9 lb in)

Connect the electrical connection (3) for the PEU.

DEF Tank Mounting and Installation

Type 1 DEF Tank

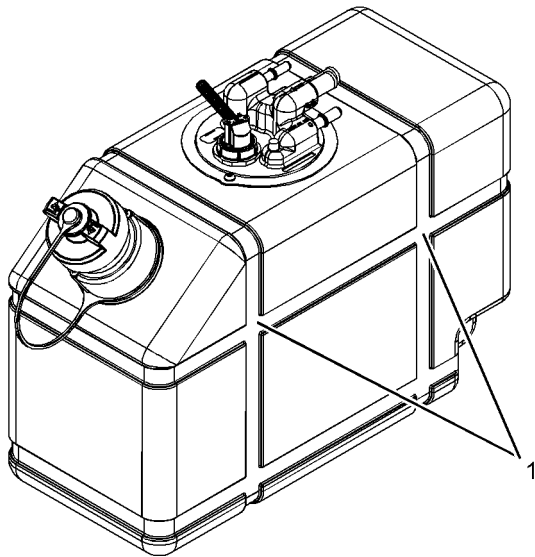

Illustration 34

g03707722

Typical example

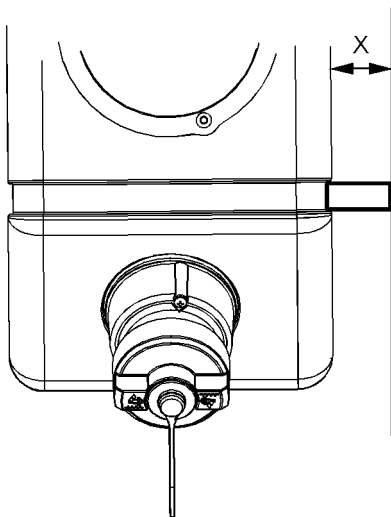

Illustration 35

g03707723

Typical example

Type 1 DEF tanks must be installed to the application with the following criteria:

- The bottom of the DEF Tank must be fully supported by a structural platform. Full support is defined as a continuous material that is at least as large as the dimensions of the bottom of the tank. Structural is defined as being able to support full tank mass with application load without plastic deformation or failure.

- An anti-friction rubber mat under the bottom of the tank is required. If the installation uses DEF tank stops, the anti-friction device must also be between the stops and the DEF tank.
- Any metallic surfaces contacting the tank should be free of burrs, welds, foreign objects, and sharp edges.
- The tank strap must be located correctly. The DEF tank has strap grooves (1) incorporated into the DEF tank to help keep the strap in place.
- A minimum clearance of 9 mm (0.35433 inch) (X) on all sides is required with thick straps in the grooves.
- The straps should be long enough to support the dimensions of the fasteners. If there is not enough free fastener length, assembly may be difficult.
- A locked joint is a requirement and can be accomplished by using either a jam nut or lock nut.
- The tank straps require a preload when installed. Thermal expansion and contraction of the tank may loosen the straps if a preload is not applied. The preload is a balance between enough preload to form the strap, to resist slip, to prevent excessive plastic deformation of the tank and having adequate life for the components.

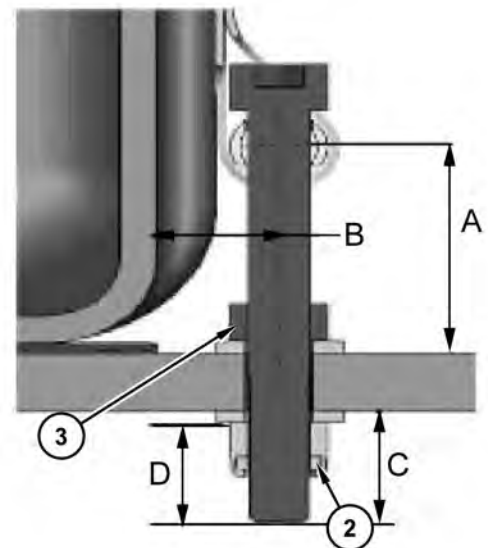

Illustration 36

g03711537

Typical example

- (2) Lock nut or weld nut
- (3) Jam nut
- (A) 45 mm (1.77 inch)
- (B) 20 mm (0.79 inch)
- (C) 24.25 mm (0.95 inch)
- (D) 21.75 mm (0.86 inch)

For DEF tanks that have been supplied by the engine manufacturer, following strap design is recommended:

- The strap size should have a width of 30 mm (1.18 inch) and a thickness of 1.5 mm (0.06 inch).
- The strap material should be stainless steel with rubber backing.
- The bolt size should be M10 by 1.5 with a bolt length of 90 mm (3.54 inch).

The strap pre-load should be a nominal 2.5 kN (562 lb). The maximum strap pre-load should be 4 kN (900 lb).

Tighten nuts to an initial torque
 8 ± 2 N·m ((71 ± 18 lb in))

Tighten nuts to a final torque
 11 ± 1 N·m ((97 ± 9 lb in))

Type 2 DEF Tank

Type 2 DEF tanks are supplied by the Original Equipment Manufacturer (OEM). Type 2 DEF tanks are not supplied by the engine manufacturer.

The manifold (DEF) is supplied by the engine manufacturer.

The manifold (DEF) must be installed to the DEF tank as a sub assembly process.

Contact the applications engineer for the engine manufacturer if type 2 DEF tank and associated components are to be installed.

Diesel Exhaust Fluid Lines

The diesel exhaust fluid lines must be installed with the following conditions:

- Be routed as direct as possible with no excessive dips or sags
- Be routed to avoid abrasion and overheating
- Be adequately supported and not impose stress on the connector. The maximum clipping details are detailed in table 4 .
- Must fall within the length guidelines in table 5 .
- Allow for relative movement between the two components, DEF tank to DEF pump, DEF pump to DEF injector
- Do not exceed the minimum bend radii. Refer to table 6 for more information.

Table 4

Maximum clipping distances		
Connection to Clip	Clip to Clip	Electrical Cable
150 mm (6 inch)	150 to 300 mm (6 to 12 inch)	150 mm (6 inch)

Table 5

DEF Lines	Length	
	Min	Max
Suction (DEF tank to pump)	1000 mm (39.4 inch)	2000 mm (78.7 inch)
Pressure (pump to DEF injector)	1500 mm (59 inch)	4000 mm (157.5 inch)
Return (DEF injector to pump)	1500 mm (59 inch)	4500 mm (177 inch)

Note: For a 12 VDC system, the total length of the three diesel exhaust fluid lines must not exceed 9500 mm (374 inch).

Note: For a 24 VDC system, the total length of the three diesel exhaust fluid lines must not exceed 10000 mm (394 inch).

Table 6

Minimum Bend Radius	
Diesel exhaust fluid lines	56 mm (2.2 inch)
Harness	10 mm (0.39 inch)

There are three DEF lines as shown in the following table:

Table 7

DEF Line	Fitting 1	Fitting 2
DEF tank outlet to PEU inlet	DEF Tank Outlet = 3/8 inch	PEU Inlet = 3/8 inch
PEU outlet to DEF injector inlet	PEU Outlet = 5/16 inch	DEF Injector Inlet = 5/16 inch
DEF injector return to DEF tank	DEF Injector Return = 3/8 inch	DEF Tank Return = 5/16 inch

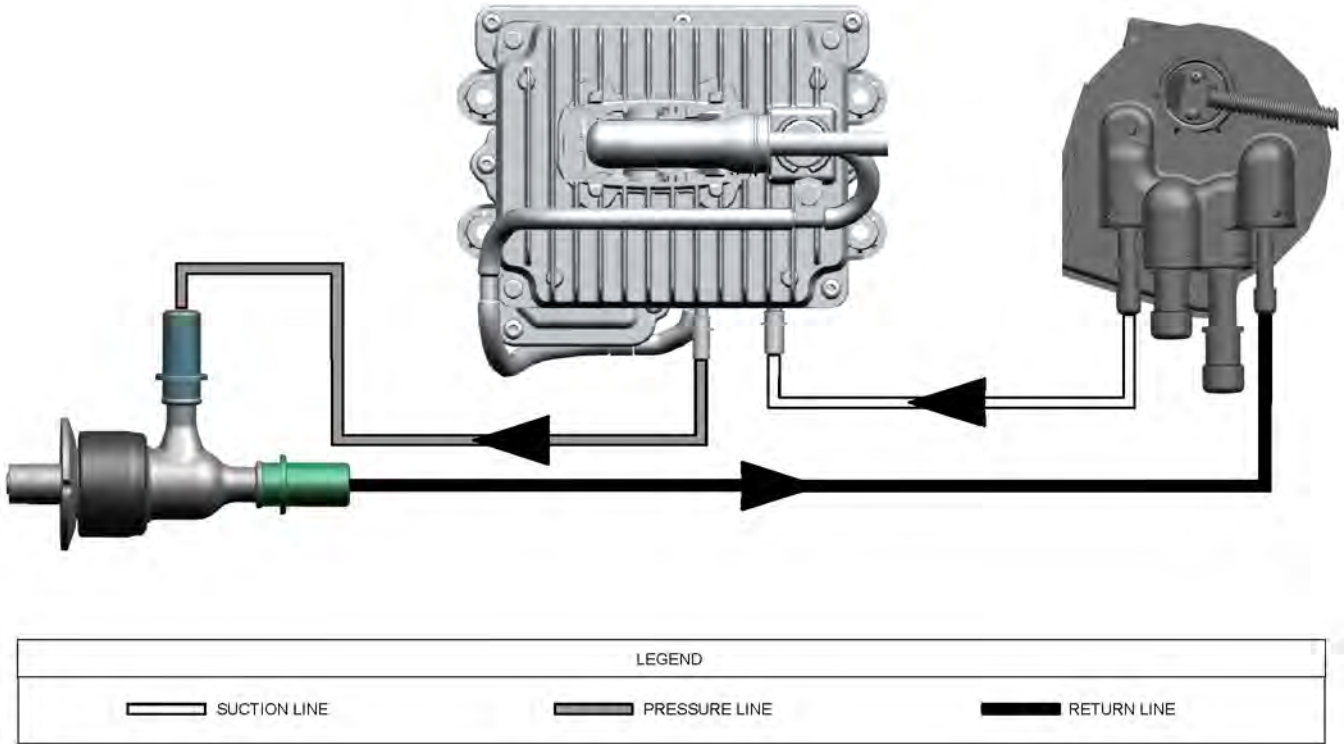

Illustration 37

g06178092

DEF line routing between components

1. Ensure that the DEF lines are clean, free from restriction, and free from wear or damage. If necessary, replace the DEF lines as an assembly.

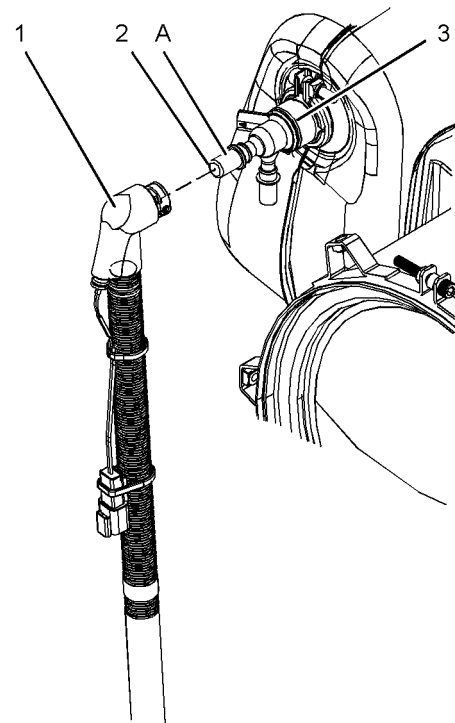

Illustration 38

g06178214

Typical example
(A) DEF injector outlet

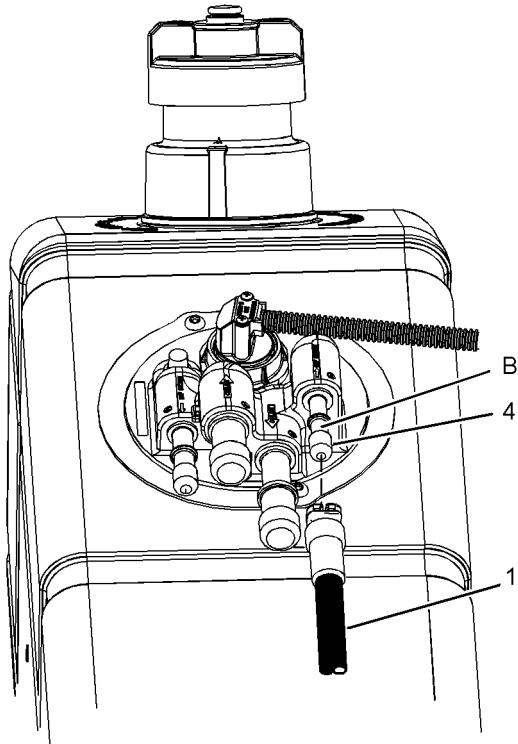

Illustration 39

g06178205

Typical example
(B) DEF tank inlet

2. Remove cap (2) from outlet connection (A) on DEF injector assembly (3). Remove the plugs from DEF line (1). Connect the DEF line to DEF injector outlet connection (A).

Remove cap (4) from DEF tank inlet connection (B). Connect the other end of DEF line (1) to DEF tank inlet connection (B).

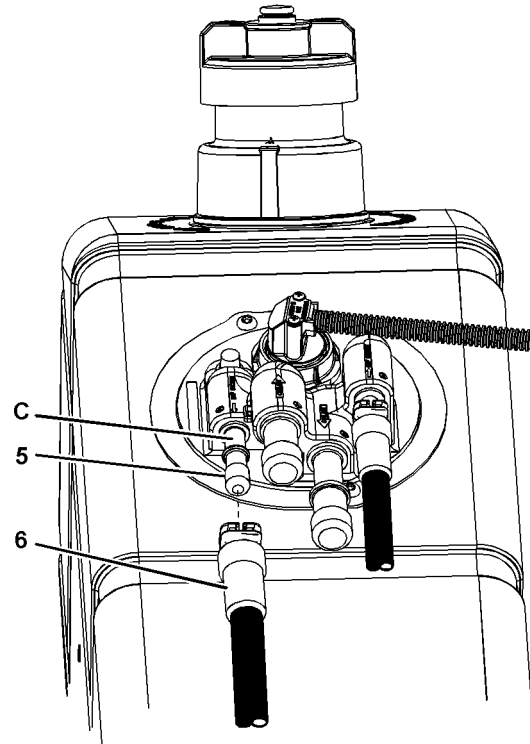

Illustration 40

g06178253

Typical example
(C) DEF tank outlet

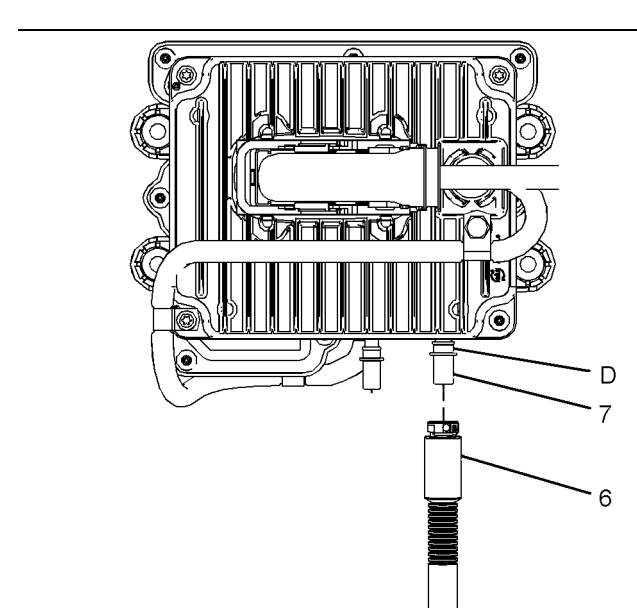

Illustration 41

g06177754

Typical example
(D) DEF pump inlet

3. Remove cap (5) from DEF tank outlet connection (C). Remove the plugs from DEF line (6). Connect DEF line (6) to DEF tank outlet connection (C).

Remove cap (7) from DEF pump inlet connection (D). Connect the other end of DEF line (6) to DEF pump inlet connection (D).

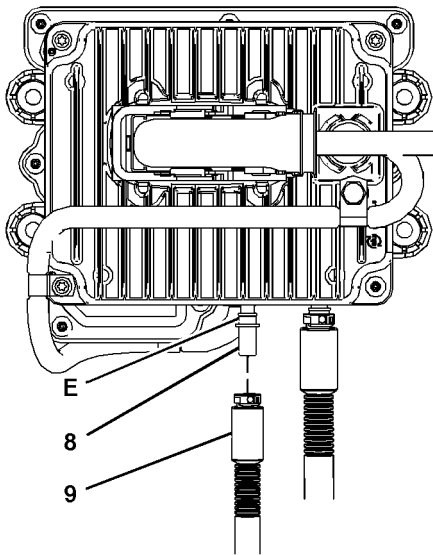

Illustration 42 g06178544
 Typical example
 (E) DEF pump outlet

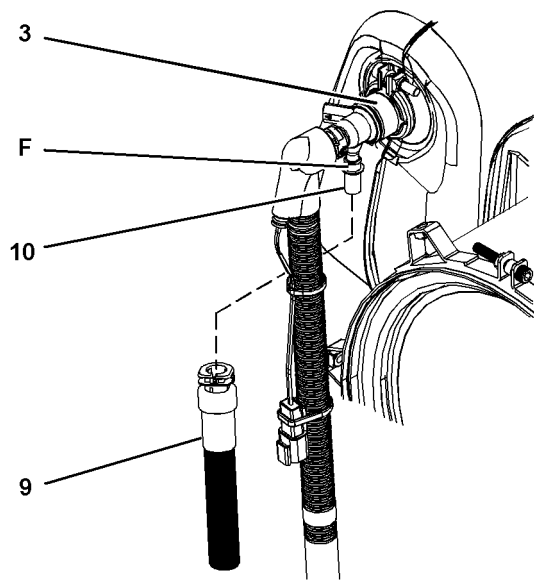

Illustration 43 g06178555
 Typical example
 (F) DEF injector inlet

4. Remove cap (8) from DEF pump outlet connection (E). Remove the plugs from DEF line (9). Connect DEF line (9) to DEF pump outlet connection (E).

Remove cap (10) from DEF injector inlet connection (F). Connect the other end of DEF line (9) to DEF injector inlet connection (F).

5. Connect the DEF line heater connections for the DEF lines.

Coolant Diverter Valve

The coolant diverter valve must be on the inlet side of the manifold (DEF Heater), between the engine and manifold (DEF Heater). The coolant diverter valve must be mounted vertically ± 5 degrees.

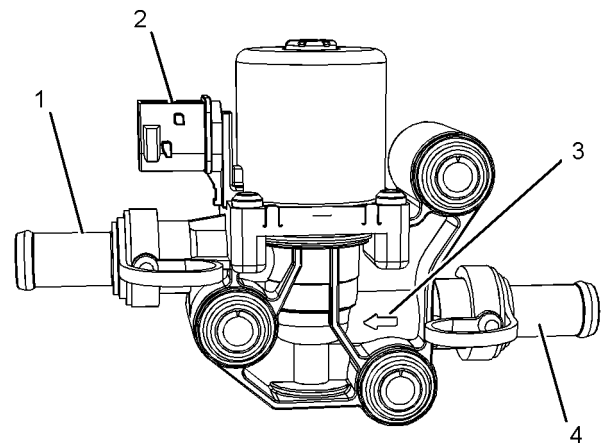

Illustration 44 g03693757
 Typical example

Note: The arrow on the coolant diverter valve (3) indicates the direction flow of coolant through the coolant diverter valve.

The coolant diverter valve must be mounted with three M8 bolts. Tighten the M8 bolts of the following torque 22 N·m (195 lb in).

Quick coolant connectors are supplied with the coolant diverter valve. The OEM may provide 16 mm (0.625 inch) SAEJ2044 connectors if necessary.

1. Connect coolant tube assemblies to connection (1) and connection (4).
2. Connect harness assembly to electrical connection (2).

Coolant Connections

Coolant must be supplied from the engine to the manifold (DEF Heater) to heat the DEF tank. The coolant is supplied via the diverter valve controlled via the dosing control module.

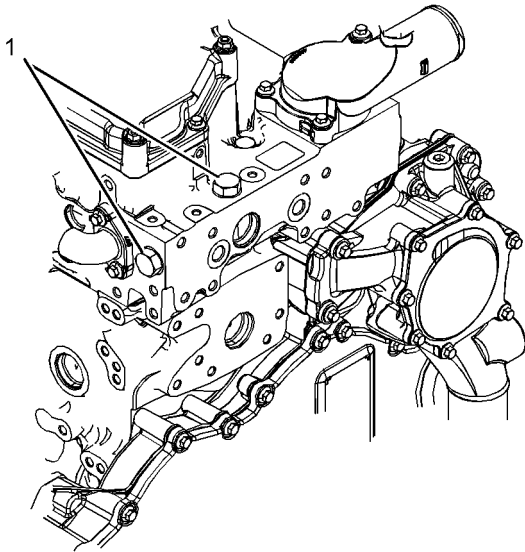

Illustration 45
Typical example

g03694452

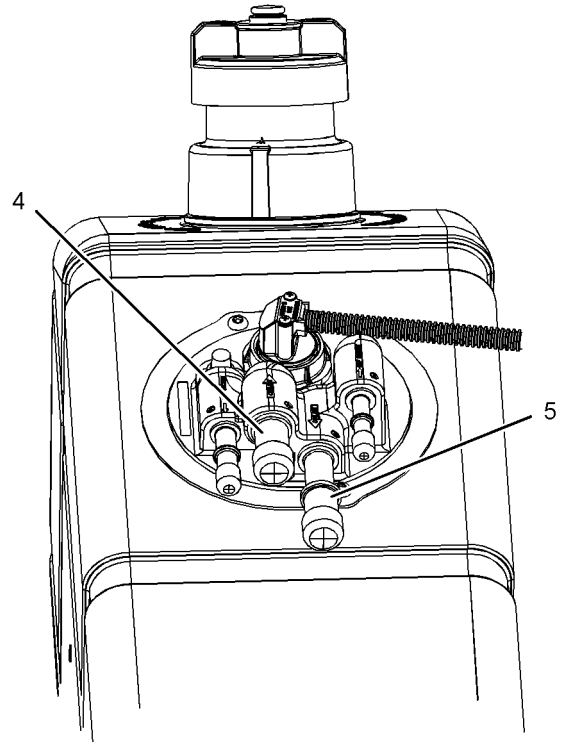

Illustration 47
Typical example

g03694455

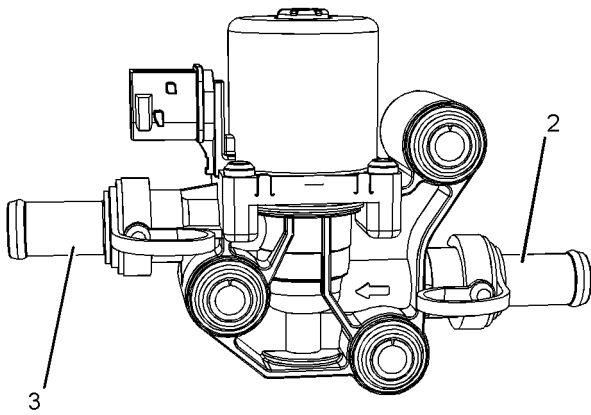

Illustration 46
Typical example

g03694454

Coolant is taken from the coolant outlet (1) on the engine to the inlet of the coolant diverter valve (2). Then the coolant flows from the outlet of the coolant diverter valve (3) to the inlet coolant connection (4) on the manifold (DEF Heater).

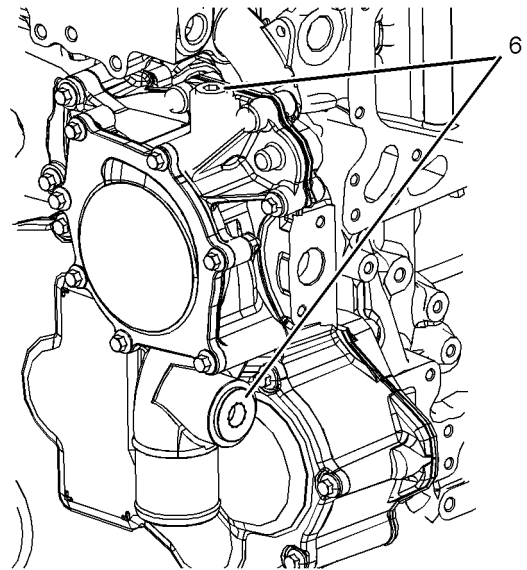

Illustration 48
Typical example

g03694460

Then the coolant flows from the outlet coolant connection (5) on the manifold (DEF Heater) back to the inlet connection on the engine (6).

Fuel Cooler for 1206F-E70TA, and 1206F-E70TTA, 1204F-E44TA, 1204F-E44TTA Engines

The fuel cooler can be supplied loose.

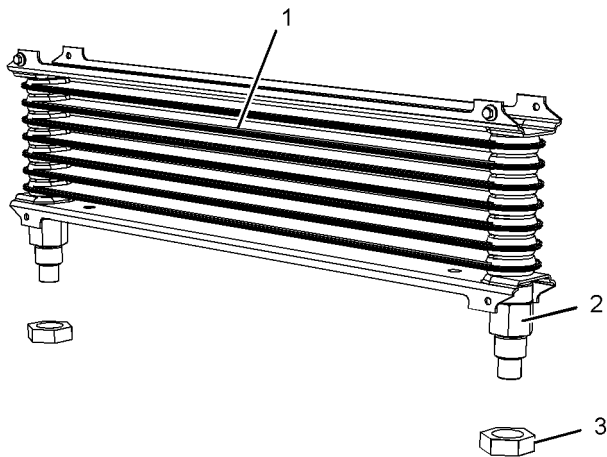

Illustration 49

g03179997

Typical example

Install the fuel cooler (1) to the application.

Install the nuts (3) finger tight. Tighten the nuts to a torque of $35 \pm 5 \text{ N}\cdot\text{m}$ ($26 \pm 4 \text{ lb ft}$).

Note: Ensure that the 30 mm (1.18 inch) hexagonal connection (2) is secure when the nuts (3) are tightened.

Fuel Filter (In-Line) for 1206F-E70TA, and 1206F-E70TTA, 1204F-E44TA, 1204F-E44TTA Engines

The fuel filter (In line) can be supplied loose.

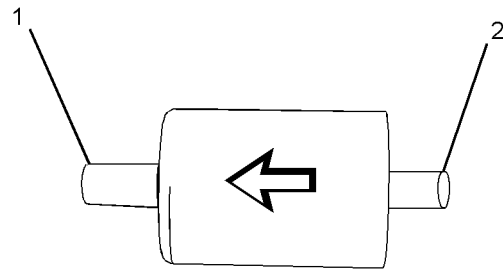

Illustration 50

g03178796

Typical example

The fuel filter (In line) has an inlet connection of 12.7 mm (0.5 inch) (2). The fuel filter (In line) has an outlet connection of 10 mm (0.39 inch) (1).

Note: Ensure that the flow of fuel through the fuel filter (In line) follows the direction as shown in illustration 50.

Fuel Priming Pump (Electric Fuel Lift Pump (EFLP)) for 1206F-E70TA, and 1206F-E70TTA, 1204F-E44TA, 1204F-E44TTA Engines

The fuel priming pump can be supplied loose.

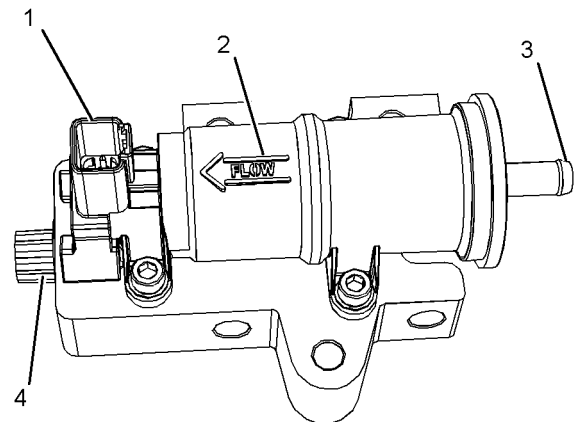

Illustration 51

g03691471

Typical example

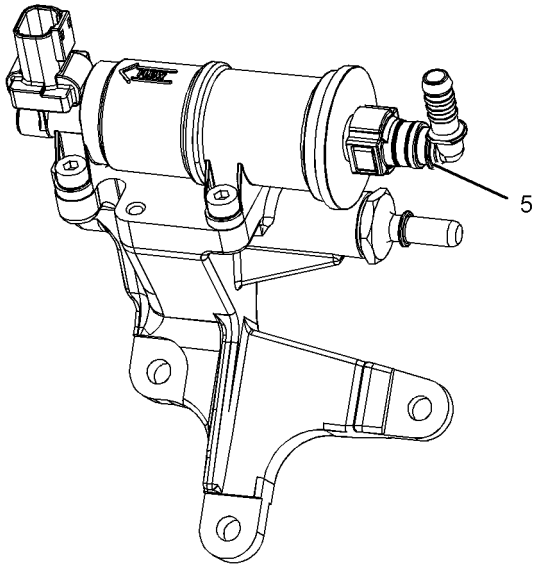

Illustration 52

g03725234

Typical example

1. Remove plug (4). Connect plastic tube assembly to fuel priming pump (2).

Note: In some applications, the customer should install a connection after plug (4) is removed. The connection should be tightened to a torque of 20 N·m (177 lb in).

2. Install fuel priming pump (2) to the application.
3. Connect hose assembly to the 10 mm (0.39 inch) inlet connection (2) of the fuel priming pump.

Note: For some applications, the customer must connect to the SAE J2044 connection (5).

4. Connect the harness assembly to fuel priming pump connection (1).

Note: Ensure that the flow of fuel through the fuel priming pump follows the direction as shown in illustration 51.

Water Separator and Fuel Filter (Primary) for 1206F-E70TA, and 1206F-E70TTA, 1204F-E44TA, 1204F-E44TTA Engines

The water separator and fuel filter (primary) (1) can be supplied loose. The following components will be supplied.

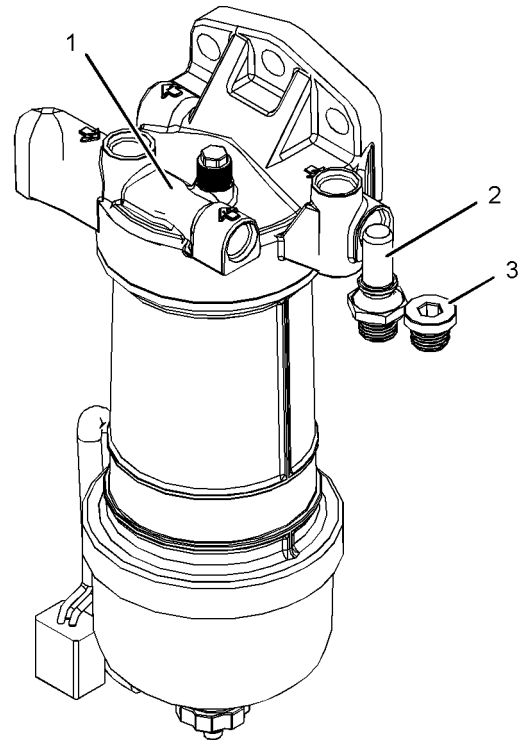

Illustration 53

g03178977

Typical example

- Connectors (2)
- M16 by 1.5 sealing plugs (3)

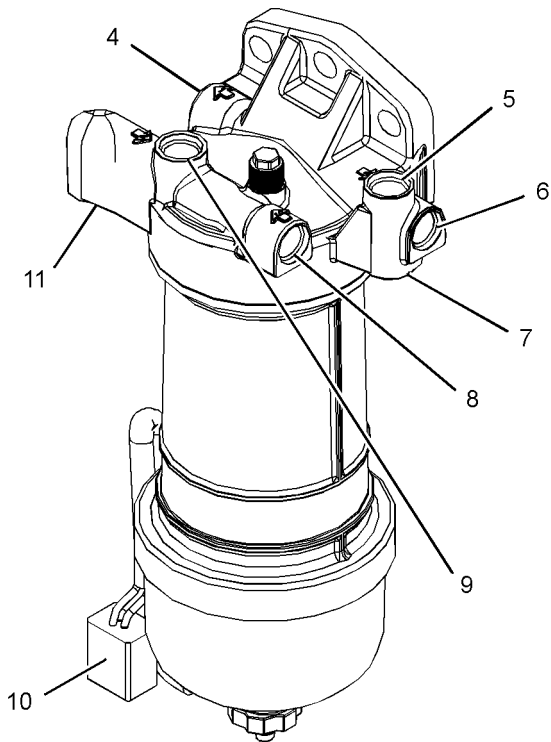

Illustration 54

g03179003

Typical example

Ports (9)(8), and (11) are inlet connections.

Ports (4)(5)(6), and (7) are outlet connections.

Install connectors (3) and sealing plugs (2) to the inlet ports and outlet ports. Tighten the connectors and sealing plugs to a torque of $17 \pm 2 \text{ N}\cdot\text{m}$ ($150 \pm 18 \text{ lb in}$).

Tighten water in fuel sensor (10) hand tight.

Note: If harness assembly is cable strapped, remove cable strap from harness assembly.

Remote Engine Oil Filter Base for 1204F-E44TA, 1204F-E44TTA Engines

On certain engines, a remote mounted engine oil filter base may be used.

Cleanliness

- Maximum dirt level within oil filter base is 5 mg.
- Maximum dirt level within fluid handling hoses and pipe work is 6 mg/m length.
- Maximum particle size within fluid handling hoses and pipe work is non-rubber particle size of 125 microns maximum.

- Maximum particle size within fluid handling hoses and pipe work is rubber particle size of 600 microns maximum.

1. Position remote mounted engine oil filter base to the application. Install recommended M8 fasteners to engine oil filter base. Tighten M8 fasteners to a tightening torque of $22 \text{ N}\cdot\text{m}$ (195 lb in).
2. Follow Step 2.a through Step 2.c to install the connection to the remote mounted engine oil filter base.

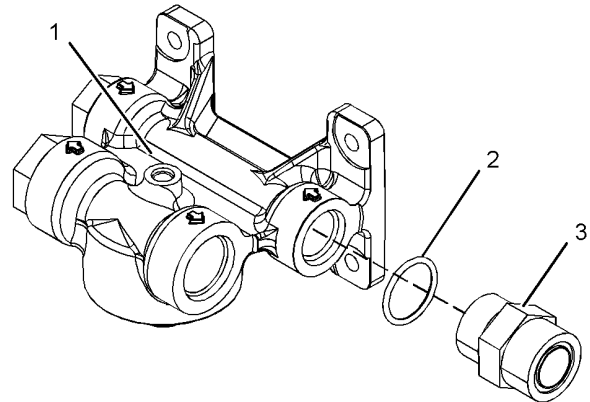

Illustration 55

g03692720

Typical example

- a. Install O-ring (2) to connection (3).
- b. Install connection (3) to oil filter base (1).
- c. Tighten connection (3) to a torque of $65 \pm 10 \text{ N}\cdot\text{m}$ ($48 \pm 7 \text{ lb ft}$).

3. Follow Step 3.a through Step 3.d to install the elbow to the engine oil filter base.

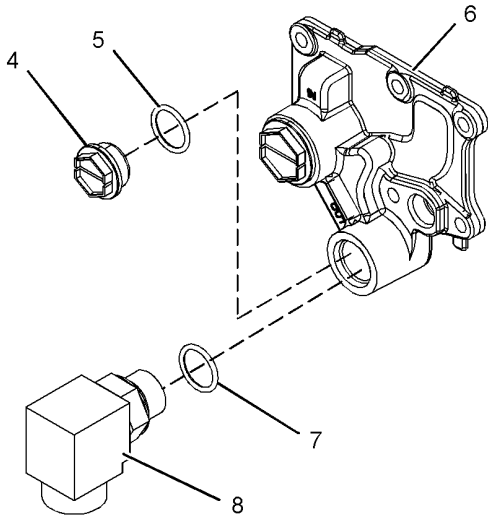

Illustration 56 g03692759
Typical example

- a. Remove plug (4) and O-ring (5) from engine oil filter base (6).
- b. Install O-ring (7) to elbow (8).
- c. Install elbow (8) to engine oil filter base (6).
- d. Tighten elbow (8) to a torque of $65 \pm 10 \text{ N}\cdot\text{m}$ ($48 \pm 7 \text{ lb ft}$).

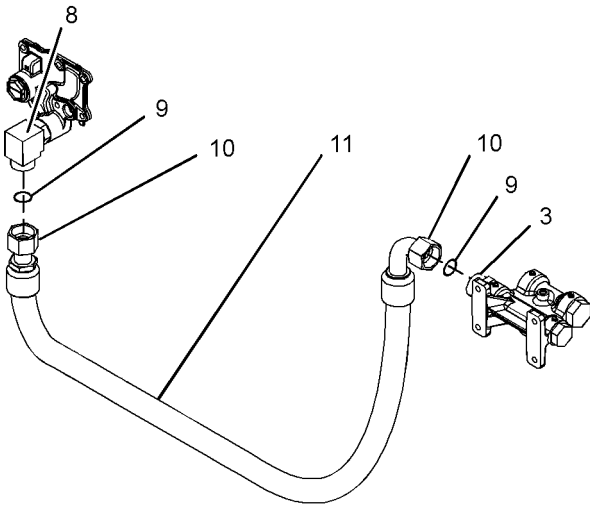

Illustration 57 g03692776
Typical example

4. Install O-rings (9) to connections (10) at each end of hose assembly (11).
5. Install connections (10) of hose assembly (11) to connection (3) and elbow (8).

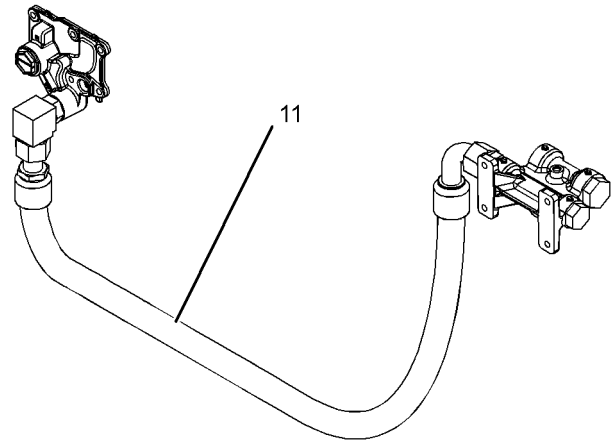

Illustration 58 g03693261
Typical example

6. Tighten connections (10) at each end of hose assembly (11) to a torque of $65 \pm 10 \text{ N}\cdot\text{m}$ ($48 \pm 7 \text{ lb ft}$). Ensure that hose assembly (11) is installed in the correct orientation. Refer to illustration 58.

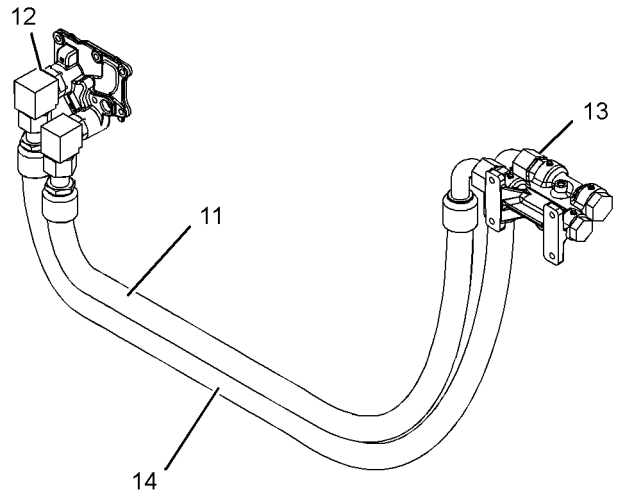

Illustration 59 g03693263
Typical example

7. Follow Step 2.a through Step 2.c to install the connection to the remote mounted engine oil filter base. Tighten connection (13) to a torque of $90 \pm 13 \text{ N}\cdot\text{m}$ ($66 \pm 10 \text{ lb ft}$).
8. Follow Step 3.a through Step 3.d to install the elbow to the engine oil filter base. Tighten elbow (12) to a torque of $90 \pm 13 \text{ N}\cdot\text{m}$ ($66 \pm 10 \text{ lb ft}$).

9. Follow Step 4 through Step 6 to install the second hose assembly. Ensure that hose assembly (14) is installed in the correct orientation. Refer to illustration 59.

Soot Sensor for 1206F-E70TA, and 1206F-E70TTA Engines

The soot sensor module (2) is supplied with pre-determined lengths of coax cable.

Fasten the soot sensor module (2) using washers and two M6 bolts. Tighten the bolts to a torque of $12 \pm 3 \text{ N}\cdot\text{m}$ ($106 \pm 27 \text{ lb in}$).

Once the soot sensor module has been installed, ensure that the cables are routed to the following specifications.

- Rubber grommets should be used in any holes that the cable is routed into.
- Holes should have a minimum diameter of 16 mm (0.63 inch) for the antenna connectors to pass through.
- Retention points are at 200 to 450 mm (8 to 18 inch) intervals
- Ensure that suitable clips are used to retain the cable.
- Any spare cable length shall be coiled, not bundled.
- The spare cable length should be properly retained at the center of mass to a single fix structure.
- The bend radius or the coil should be no less than 51 mm (2 inch) at any point
- The cables should avoid sharp metal edges and are not restricted.

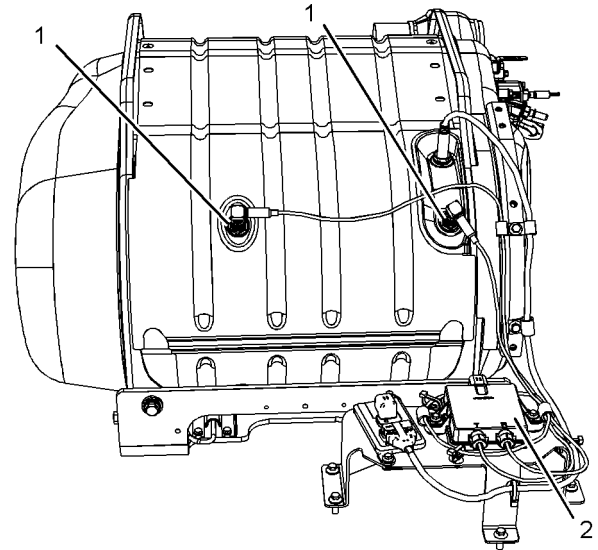

Illustration 60

g03393606

Typical example

Connect the coax cables to the antenna connections (1) on the Clean Emissions Module (CEM). Tighten the connections to a torque of $1.2 \pm 0.2 \text{ N}\cdot\text{m}$ ($11 \pm 1.8 \text{ lb in}$).

Soot Sensor for 1204F-E44TA, and 1204F-E44TTA Engines (If equipped)

The soot sensor module is supplied with pre-determined lengths of coax cable.

Fasten the soot sensor module using washers and two M6 bolts. Tighten the bolts to a torque of $12 \pm 3 \text{ N}\cdot\text{m}$ ($106 \pm 27 \text{ lb in}$).

Once the soot sensor module has been installed, ensure that the cables are routed to the following specifications.

- Rubber grommets should be used in any holes that the cable is routed into.
- Holes should have a minimum diameter of 16 mm (0.63 inch) for the antenna connectors to pass through.
- Retention points are at 200 to 450 mm (8 to 18 inch) intervals
- Ensure that suitable clips are used to retain the cable.
- Any spare cable length shall be coiled, not bundled.
- The spare cable length should be properly retained at the center of mass to a single fix structure.

- The bend radius or the coil should be no less than 51 mm (2 inch) at any point
- The cables should avoid sharp metal edges and are not restricted.

Connect the coax cables to the antenna connections on the Clean Emissions Module (CEM). Tighten the connections to a torque of 1.2 ± 0.2 N·m (11 ± 1.8 lb in).

Nitrogen Oxide Sensor for 1206F-E70TA, and 1206F-E70TTA Engines

Note: There are two NOx sensors. One sensor should be installed in the Clean Emissions Module (CEM). The other sensor should be installed into the exhaust tail pipe at a suitable position.

Note: The NOx sensor that should be installed in the CEM has a black cable. The NOx sensor that should be installed in the exhaust tail pipe has a gray cable. If the sensing unit is installed in the wrong location, a diagnostic code will be come active.

Certain transportation, storage, and handling recommendations are listed below:

- Shipping boxes should be transported and stored in a closed condition. Store the sensors in the original, closed shipping box until the sensor is ready for use. The maximum storage time in production packaging boxes is 18 months after production. The maximum storage time in spare part packaging is 2 years after production.
- Sensors should be stored in a temperature range of -40° C to 105° C.
- Handle and store the NOx sensor in a clean, dry area, free of contamination, and inclement weather.
- Avoid temperature shock when opening a shipping box. Avoid a temperature difference of more than $\pm 5^{\circ}$ C between the sensors and the environment. Allow at least 4 hours for the sensors to reach ambient temperature before opening the box to avoid condensation on the parts.
- Do not open the shipping box with a knife that will deeply penetrate the box. The knife may damage the sensors or sensor cables.
- Do not remove the sensing unit protective cap until the sensor is ready for installation into the exhaust system.
- Avoid impact to the NOx sensor, dropping the sensor could cause permanent damage. If the sensor has had an impact, discard the sensor.
- Do not paint any part of the sensing unit.

- Do not clean any part of the sensor with chemical cleaners.

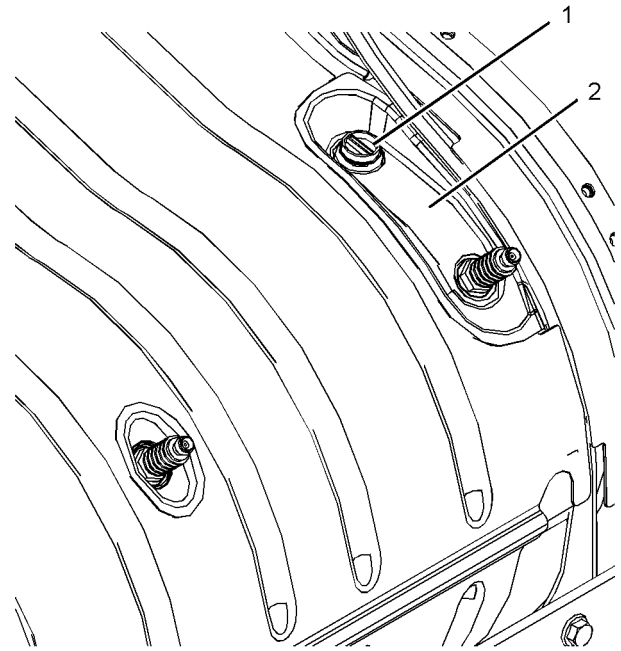

Illustration 61

g03393625

Typical example

1. Remove cap (1) from Clean Emissions Module (CEM) (2). Ensure that the internal threads are clean and free from debris.

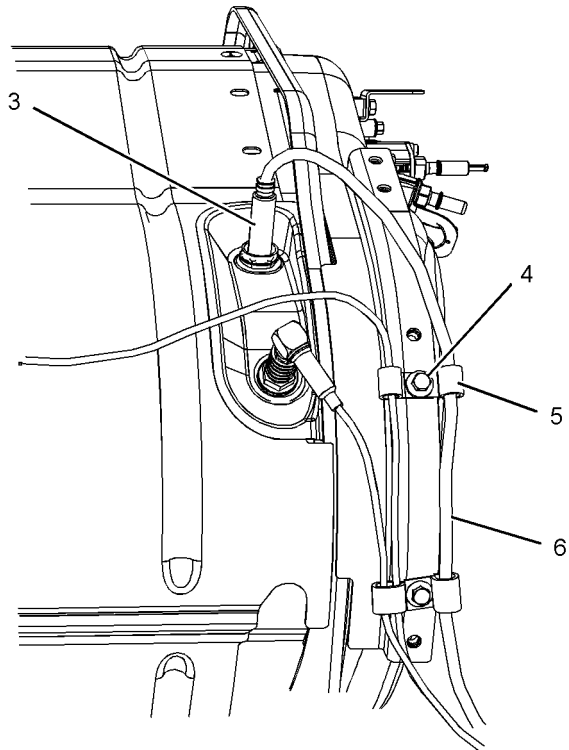

Illustration 62

g03393964

Typical example

2. Remove protective cap from sensor. Ensure that the threads of NOx sensor have sufficient anti-seize compound applied. Install NOx sensor (3) to the assembly of the clean emissions module. Tighten the NOx sensor to a torque of $50 \pm 10 \text{ N}\cdot\text{m}$ ($37 \pm 7 \text{ lb ft}$).
3. Connect harness assembly (6) to connection.
4. Secure harness assembly (6) in the correct position with clips (5). Install bolts (4) to clips (5). Tighten the bolts (4) to a torque of $28 \text{ N}\cdot\text{m}$ (248 lb in).

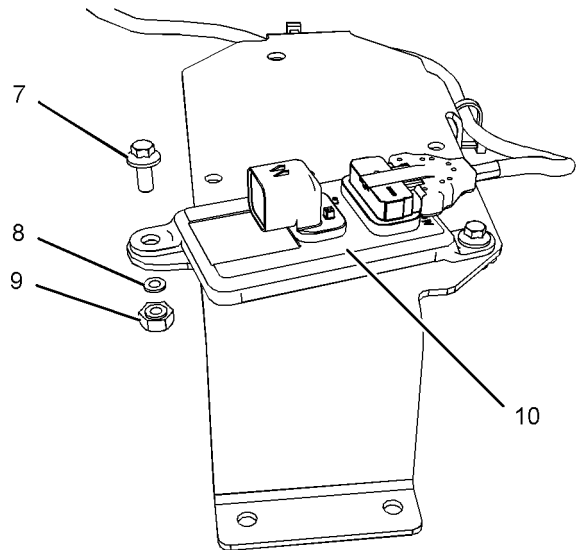

Illustration 63

g03393970

Typical example

5. Position the NOx sensor control module (10) to the application. Install bolts (7), washers (8), and nuts (9).

Note: Two bolts should be used to secure the sensor unit to the application. The preferred fastener is an M6 bolt with a flanged head to distribute the load.

6. Tighten the 8.8 grade bolts to a torque of $9 \text{ N}\cdot\text{m}$ (80 lb in). Tighten the 10.9 grade bolts to a torque of $12 \text{ N}\cdot\text{m}$ (106 lb in).

Ensure the harness between the sensor and the first clipping point is not pulled tight. There should be enough slack to prevent strain on the grommet through vibrations and pulling.

The harness must be routed such that the harness exits the grommet at no more than an angle of 15 degrees to the longitudinal axis of the Sensing Element Assembly (SEA). Strain relief of the harness is required.

Ensure that the cables to the sensor body and the sensing unit are not bent. Clip any detached wiring harness components with cable ties to prevent the harness chafing against other components. Ensure that cable straps meet the Original Equipment Manufactures (OEM) specification.

The harness should be secured every 152.4 mm (6 inch) or less of length. The bend radius of the harness should exceed 20 mm (0.7874 inch).

The sensor body must be mounted so that the maximum ambient temperature does not exceed 85°C (185°F).

The longitudinal axis of the sensing unit must be within 10 degrees of perpendicular to the exhaust flow.

Nitrogen Oxide (NOx) Sensor for 1204F-E44TA, and 1204F-E44TTA Engines

Note: There are two NOx sensors. One sensor can be installed in the flexible exhaust pipe assembly or can be installed in the CEM. The other sensor should be installed into the exhaust tail pipe at a suitable position.

Note: The first NOx sensor has a black cable. The NOx sensor that should be installed in the exhaust tail pipe has a gray cable. If the sensing unit is installed in the wrong location, a diagnostic code will be come active.

Certain transportation, storage, and handling recommendations are listed below:

- Shipping boxes should be transported and stored in a closed condition. Store the sensors in the original, closed shipping box until the sensor is ready for use. The maximum storage time in production packaging boxes is 18 months after production. The maximum storage time in spare part packaging is 2 years after production.
- Sensors should be stored in a temperature range of -40°C to 105°C .
- Handle and store the NOx sensor in a clean, dry area, free of contamination, and inclement weather.
- Avoid temperature shock when opening a shipping box. Avoid a temperature difference of more than $\pm 5^{\circ}\text{C}$ between the sensors and the environment. Allow at least 4 hours for the sensors to reach ambient temperature before opening the box to avoid condensation on the parts.
- Do not open the shipping box with a knife that will deeply penetrate the box. The knife may damage the sensors or sensor cables.
- Do not remove the sensing unit protective cap until the sensor is ready for installation into the exhaust system.
- Avoid impact to the NOx sensor, dropping the sensor could cause permanent damage. If the sensor has had an impact, discard the sensor.
- Do not paint any part of the sensing unit.
- Do not clean any part of the sensor with chemical cleaners.

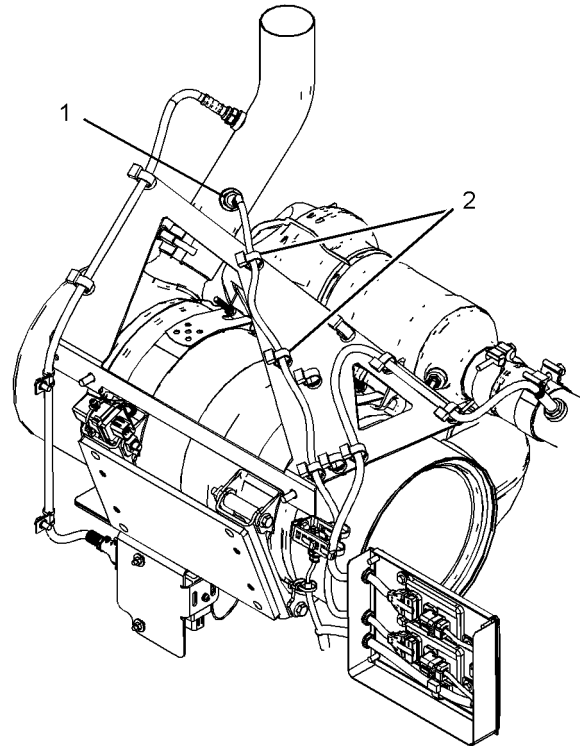

Illustration 64

g03729087

Typical example

1. Remove protective cap from sensor. Ensure that the threads of NOx sensor have sufficient anti-sieze compound applied. Install NOx sensor (1) to the OEM tube assembly. Tighten the NOx sensor to a torque of $50 \pm 10\text{ N}\cdot\text{m}$ ($37 \pm 7\text{ lb ft}$).
2. Position clips (2) for the harness assembly.
3. If bolts and clips are required, install bolts to clips. Tighten the bolts to a torque of $28\text{ N}\cdot\text{m}$ (248 lb in).

Ammonia Sensor for 1204F-E70TA, and 1204F-E70TTA Engines (If equipped)

The ammonia sensor should be installed into the exhaust pipe at a suitable position.

The ammonia sensor module is supplied with a pre-determined length of cable.

Once the ammonia sensor module has been installed, ensure that the cables are routed to the following specifications.

- The cable must be installed with a correctly secured strain relief.
- Ensure that suitable clips are used to retain the cable.
- Harness should be supported every 152 mm (6 inch) or less.
- The bend radius does not exceed 20 mm (0.7874 inch) at any point.
- The cables should avoid sharp metal edges and are not restricted. Do not expose the harness to risks of abrasion or damage by any other components.
- The route of the harness must mitigate the risk of contact with hot components.
- The bend radius of the tubing should be more than 50 mm (2 inch). Do not use clips or ties on the section of tubing.

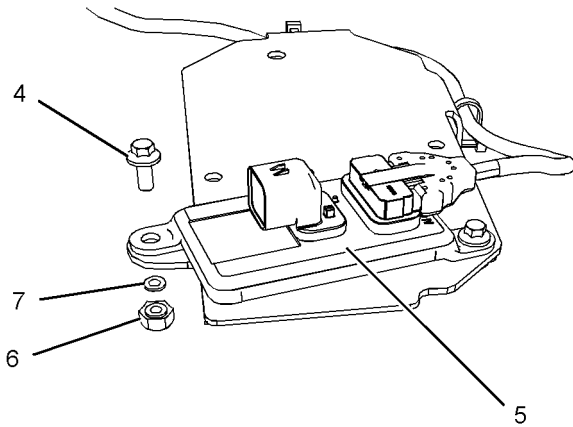

Illustration 65

g03691492

Typical example

4. Position the NOx sensor control modules (5) to the application in suitable positions. Install bolts (4), washers (7), and nuts (6).

Note: Two bolts should be used to secure the sensor units to the application. The preferred fastener is an M6 bolt with a flanged head to distribute the load.

5. Tighten the 8.8 grade bolts to a torque of 9 N·m (80 lb in). Tighten the 10.9 grade bolts to a torque of 12 N·m (106 lb in).

Ensure the harness between the sensor and the first clipping point is not pulled tight. There should be enough slack to prevent strain on the grommet through vibrations and pulling.

The harness must be routed such that the harness exits the grommet at no more than 15 degrees to the longitudinal axis of the Sensing Element Assembly (SEA). Strain relief of the harness is required.

Ensure that the cables to the sensor body and the sensing unit are not bent. Clip any detached wiring harness components with cable ties to prevent the harness chafing against other components. Ensure that cable straps meet the Original Equipment Manufactures (OEM) specification.

The harness should be secured every 152.4 mm (6 inch) or less of length. The bend radius of the harness should exceed 20 mm (0.7874 inch).

The sensor body must be mounted so that the maximum ambient temperature does not exceed 85° C (185° F).

The longitudinal axis of the sensing unit must be within 10 degrees of perpendicular to the exhaust flow.

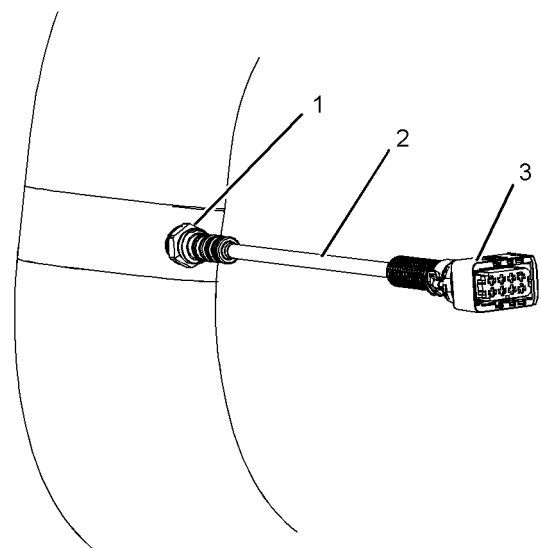

Illustration 66

g03694437

Typical example

- (2) Harness assembly
- (3) Connector

1. Remove protective cap from ammonia sensor. Ensure that the threads of ammonia sensor have sufficient anti-sieze compound applied. Install ammonia sensor (1) to the OEM tube assembly. Tighten the sensor to a torque of 50 ± 10 N·m (37 ± 7 lb ft).

Note: Ensure that the harness is not twisted when the sensor is tightened.

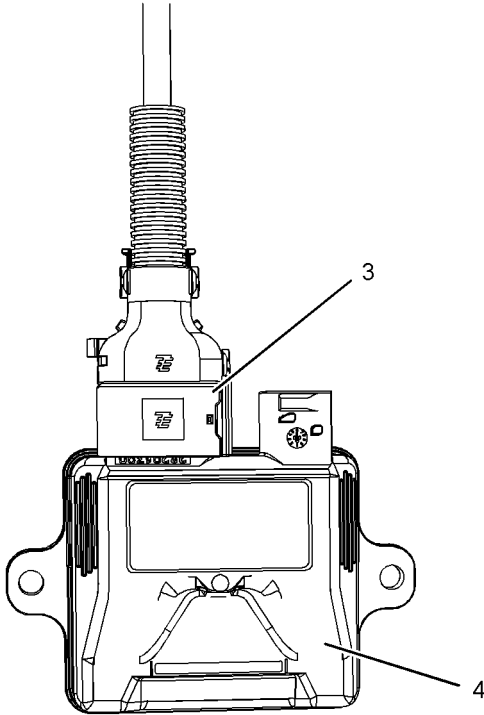

Illustration 67

g03694440

Typical example

2. Position control module (4) to a suitable position on the application. Install the two washers and the two M6 bolts to the application. Tighten the M6 bolts to a torque of 10 to 13 N·m (89 to 115 lb in).
3. Connect connection (3) to control module (4). Ensure that the connectors for the connection and control module are secure. An audible click should be heard when connector latch is closed.
4. Connect harness assembly to control module (4). Ensure that the connectors for the harness assembly and control module are secure. An audible click should be heard when connector latch is closed.

Product Lifting

Product Lifting for 1206F-E70TA, and 1206F-E70TTA Engines

NOTICE

Never bend the eyebolts and the brackets. Only load the eyebolts and the brackets under tension. Remember that the capacity of an eyebolt is less as the angle between the supporting members and the object becomes less than 90 degrees.

When it is necessary to remove a component at an angle, only use a link bracket that is properly rated for the weight.

Read all the information within produce lifting before any lifting is attempted. Ensure that the correct set of lifting eyes for the assembly to be lifted have been selected.

Engine and Clean Emission Module (CEM)

Use a hoist to remove heavy components. Use an adjustable lifting beam to lift the assembly. All supporting members (chains and cables) should be parallel to each other. The chains and cables should be perpendicular to the top of the object that is being lifted.

Clean Emission Module (CEM) Only

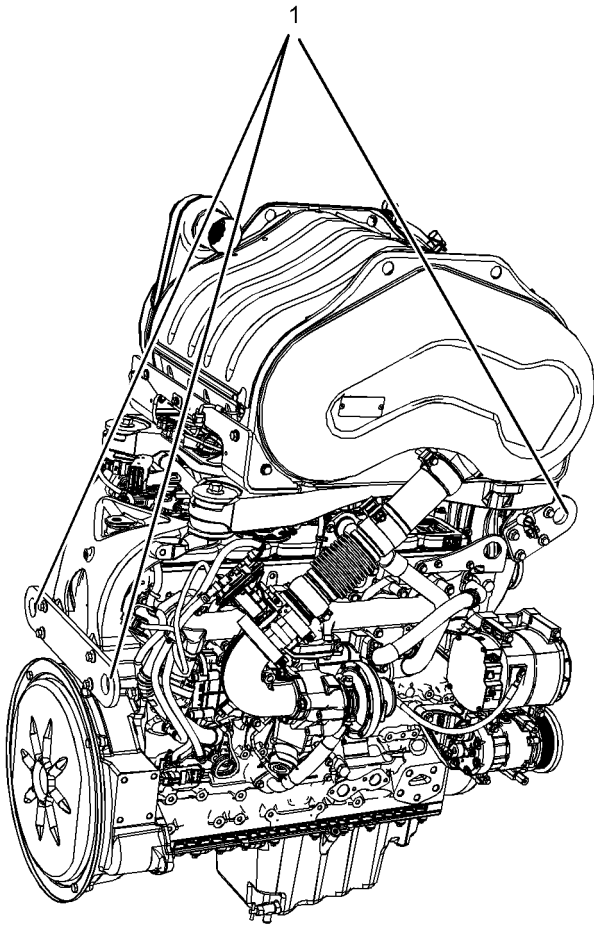

Illustration 68

g03051657

Typical example

Refer to illustration 68 for the location of the lifting eyes to lift the assembly.

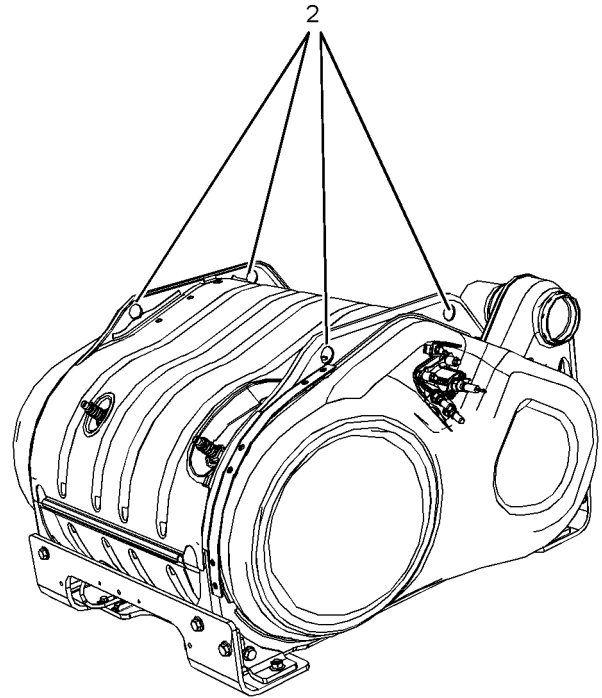

Illustration 69

g03051677

Typical example

Refer to illustration 69 for the location of the lifting eyes to lift the CEM.

Note: The weight of the CEM is approximately 110 kg (243 lb).

Pump Electronics Tank Unit (PETU) Only

The tank on the PETU should be empty before the assembly is lifted.

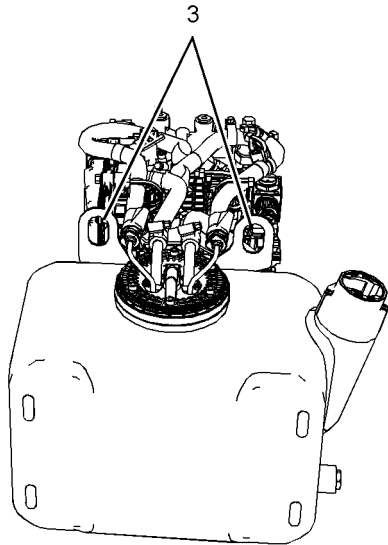

Illustration 70

g03051917

Typical example

Refer to illustration 70 for the location of the lifting eyes to lift the PETU.

Note: The weight of the PETU is approximately 18 kg (40 lb).

Engine Only

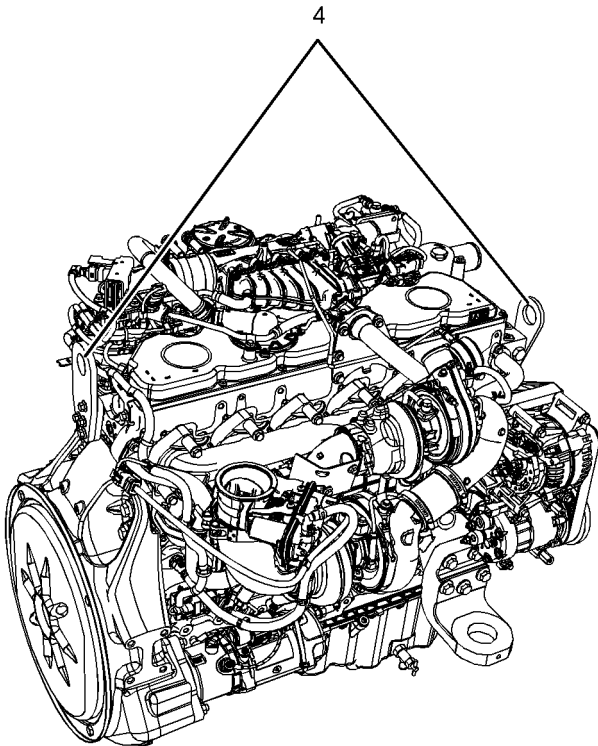

Illustration 71

g03051679

Typical example

Refer to illustration 71 for the location of the lifting eyes to lift the engine.

Product Lifting for 1204F-E44TA, and 1204F-E44TTA Engines

NOTICE

Never bend the eyebolts and the brackets. Only load the eyebolts and the brackets under tension. Remember that the capacity of an eyebolt is less as the angle between the supporting members and the object becomes less than 90 degrees.

When it is necessary to remove a component at an angle, only use a link bracket that is properly rated for the weight.

Read all the information within produce lifting before any lifting is attempted. Ensure that the correct set of lifting eyes for the assembly to be lifted have been selected.

Engine and Clean Emission Module (CEM)

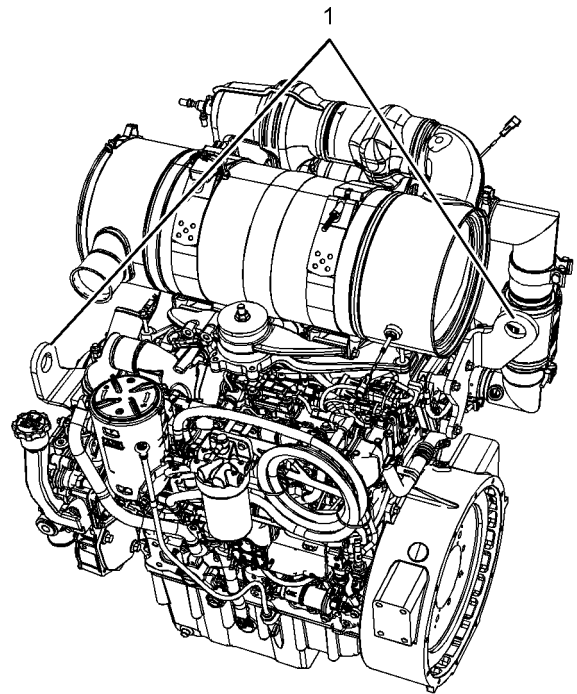

Illustration 72

g03674678

Typical example

The front lifting eye for engine and aftertreatment is installed by three bolts. The design of the lifting eyes will allow access to lift the aftertreatment and engine.

Engine Only

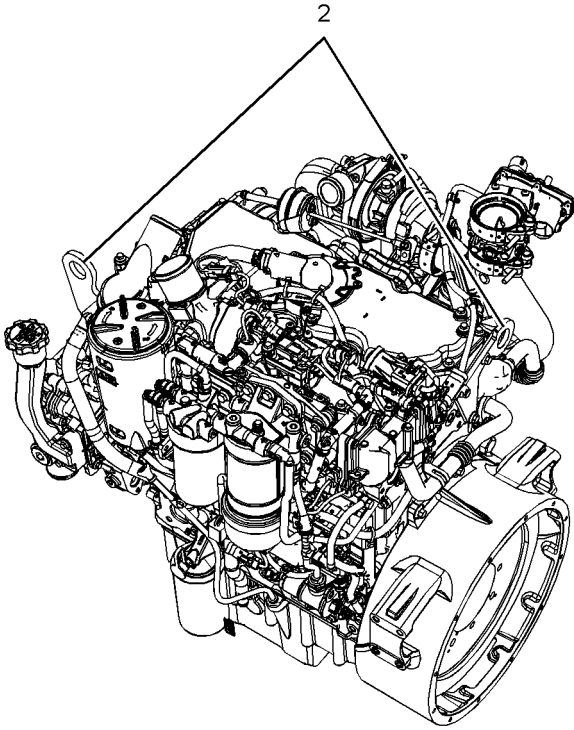

Illustration 73

g03674859

Typical example

Refer to illustration 73 for the location of the engine only lifting eyes.

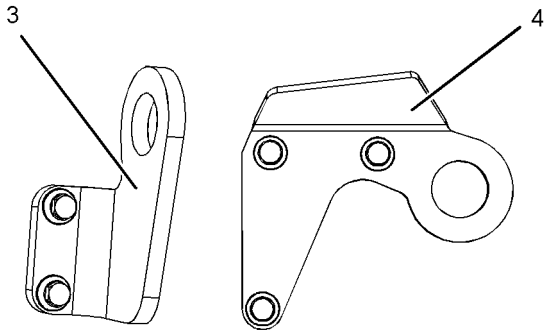

Illustration 74

g03674679

The front lifting eye (3) for the engine only is installed by two bolts. The rear lifting eye of engine only can be identified by the design.

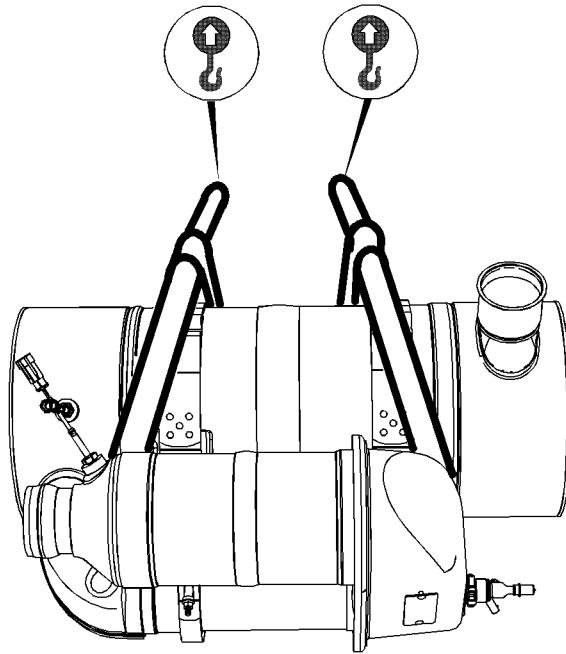

Illustration 75

g03417158

Typical example

There are two sizes of CEM that can be installed. A high powered CEM and a low powered CEM. The approximate weight of the high powered CEM is 47 kg (104 lb). The approximate weight of the low powered CEM is 42 kg (93 lb).

Two suitable double looped slings are required to lift the CEM. Also, a suitable hoist will be required to remove and install the assembly.

The slings must be attached to the CEM as shown in illustration 75.

Ensure that the slings only contact the body of the CEM. A test lift may be required to achieve the correct balance of the assembly.

Some applications may require a frame or jig to lift the CEM. Connect the frame or jig only to the cradle of the CEM. Refer to the Original equipment manufacture for more information.

Clean Emission Module (CEM) of DOC, DPF, and SCR

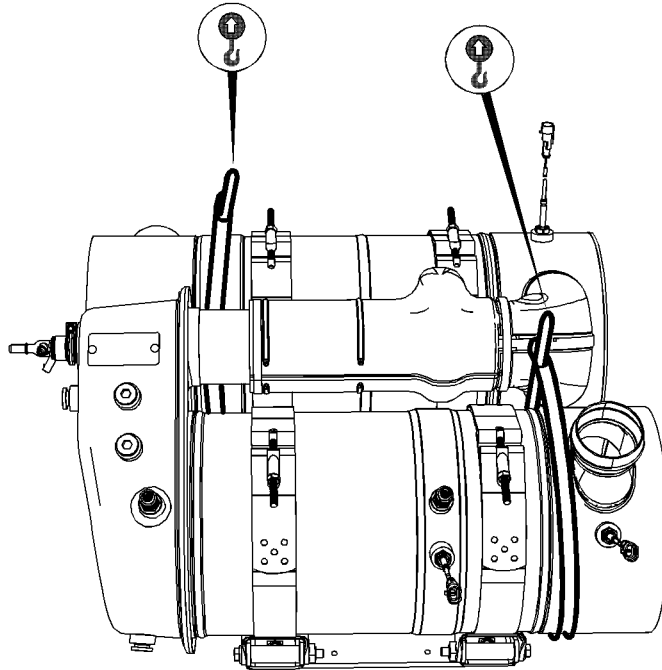

Illustration 76

g03419097

Typical example

The approximate weight of the CEM is 77 kg (170 lb).

Two suitable double looped slings are required to lift the CEM. Also, a suitable hoist will be required to remove and install the assembly.

The slings must be attached to the CEM as shown in illustration 76.

Some applications may require a frame or jig to lift the CEM. Connect the frame or jig only to the cradle of the CEM. Refer to the original equipment manufacture for more information.

Product Lifting for 854F-E34T Engines

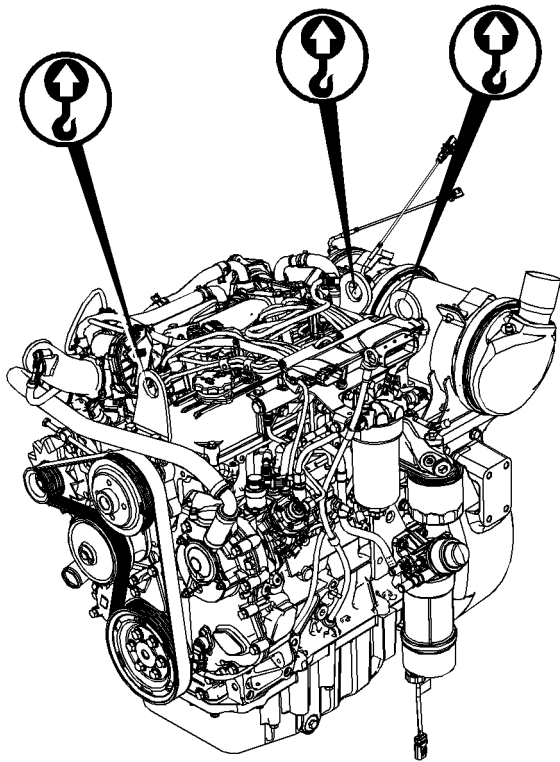

Illustration 77
Typical example

g02475658

NOTICE

Never bend the eyebolts and the brackets. Only load the eyebolts and the brackets under tension. Remember that the capacity of an eyebolt is less as the angle between the supporting members and the object becomes less than 90 degrees.

When it is necessary to remove a component at an angle, only use a link bracket that is properly rated for the weight.

Use a hoist to remove heavy components. Use an adjustable lifting beam to lift the engine. All supporting members (chains and cables) should be parallel to each other. The chains and cables should be perpendicular to the top of the object that is being lifted.

Some removals require lifting the fixtures to obtain correct balance and safety.

To remove the engine ONLY, use the lifting eyes that are on the engine.

Lifting eyes are designed and installed for specific engine arrangements. Alterations to the lifting eyes and/or the engine make the lifting eyes and the lifting fixtures obsolete. If alterations are made, ensure that correct lifting devices are provided.

Note: The engine is equipped with three lifting eyes. All the lifting eyes must be used to lift the engine.

Engine Air Cleaner for 854F-E34T Engines

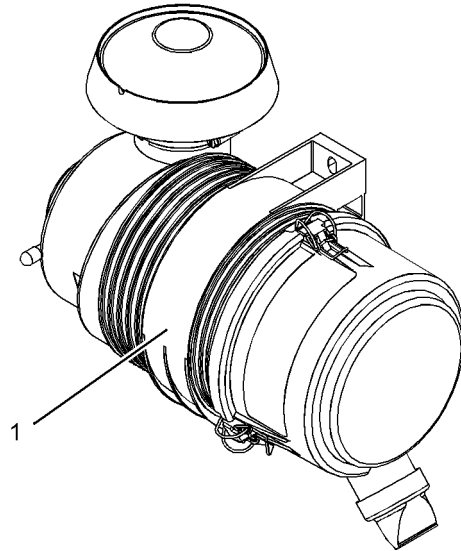

Illustration 78
Typical example

g03179402

The engine air cleaner (1) can be supplied as a loose assembly. The engine air cleaner should be mounted horizontally. The dust exhaust port must be at the lowest point and positioned in a downward direction.

Note: Do not paint the dust exhaust port. Solvents and chemicals will shorten the usable life of the exhaust port.

Note: There are several variations of engine air cleaner.

Select the appropriate sized fasteners for the relevant air cleaner. Bolts should have a flanged head or be installed with a washer under the bolt head.

Standard duty air cleaner

Tighten the M8 bolts to the following torque.
.....22 N·m ((16 lb ft))

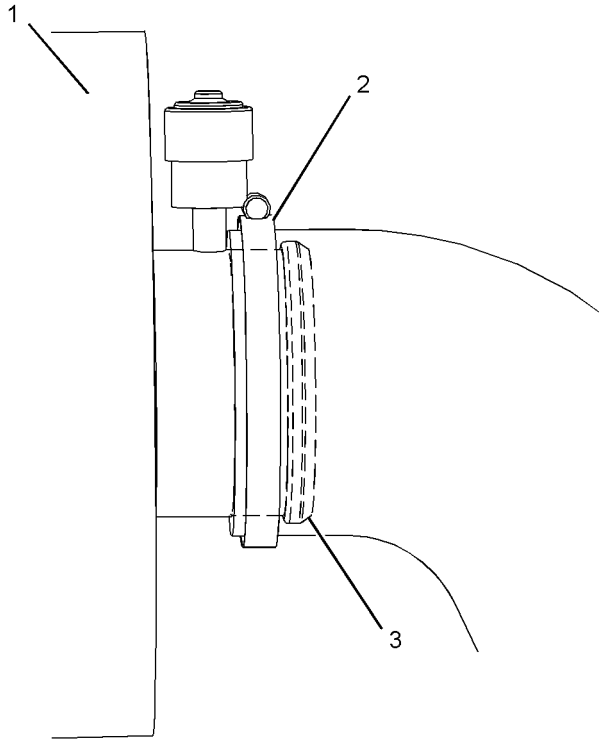

Illustration 79

g03415816

Typical example

The position of the clamp (2) in relation to pipe or component bead (3) is crucial. Ensure that clamp (2) is installed on the correct side of the pipe or component beads (3).

Air Temperature Sensor for 854F-E34T Engines

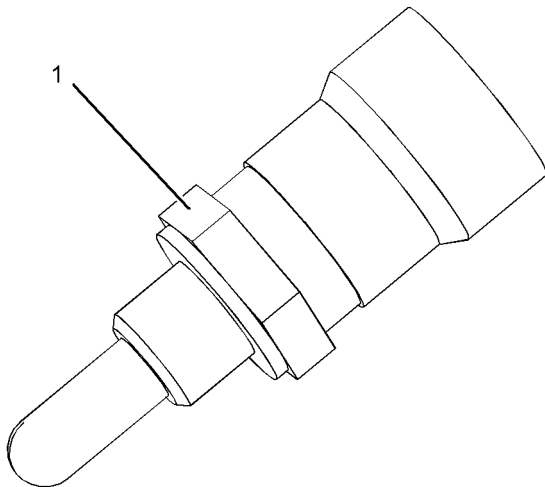

Illustration 80

g03227717

Typical example

Install the sensor (1). Tighten the sensor to a torque of $20 \pm 3 \text{ N}\cdot\text{m}$ ($177 \pm 27 \text{ lb in}$).

Installation of the Fan for 854F-E34T Engines

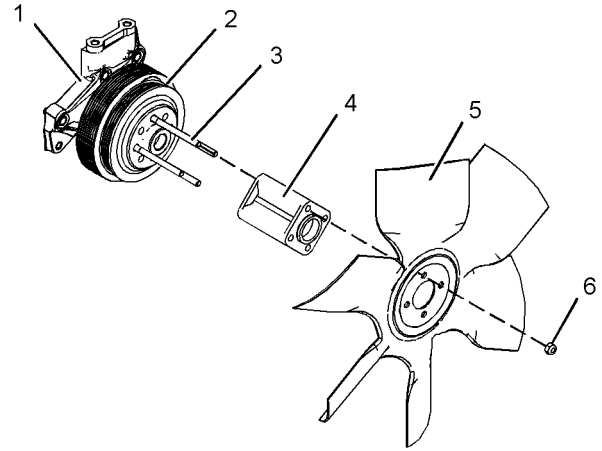

Illustration 81

g03242856

Typical example

1. Remove alternator belt.
2. Install studs (3) to fan drive (1). Tighten studs to a torque of $11 \pm 3 \text{ N}\cdot\text{m}$ ($97 \pm 27 \text{ lb in}$)
3. Install fan drive pulley (2) to fan drive (1).
4. Install alternator belt.
5. Install fan adapter (4) to studs (3).
6. Install fan (5) to studs (3).
7. Install nuts (6) to studs (3). Tighten nuts to a torque of $22 \pm 5.5 \text{ N}\cdot\text{m}$ ($195 \pm 49 \text{ lb in}$)
8. Ensure that alternator belt is the correct tension. Refer to "Installation of Alternator and Fan Belts on 854F-E34T Engines" for the correct procedure.

Installation of the Fan for 854F-E34T Engines (Engines without a Fan Drive)

1. Remove alternator belt.
2. Remove the bolts for the fan pulley. Remove fan pulley.
3. Install studs. Tighten studs to a torque of $11 \pm 3 \text{ N}\cdot\text{m}$ ($97 \pm 27 \text{ lb in}$)
4. Install fan drive pulley to studs.
5. Install alternator belt.

6. Install fan adapter to studs.
7. Install fan to studs.
8. Install nuts to studs. Tighten nuts to a torque of $22 \pm 5.5 \text{ N}\cdot\text{m}$ ($195 \pm 49 \text{ lb in}$)
9. Ensure that alternator belt is the correct tension. Refer to "Installation of Alternator and Fan Belts on 854F-E34T Engines" for the correct procedure.

Flexible Exhaust Pipe for 854F-E34T Engines

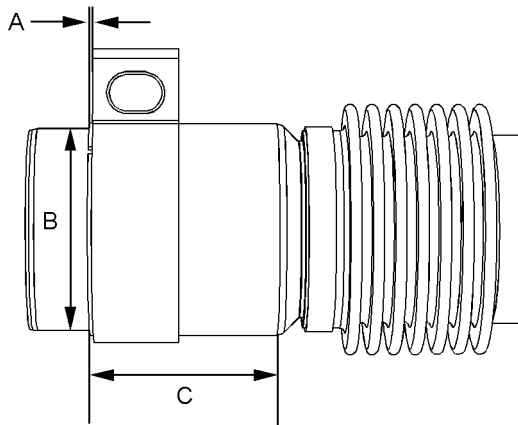

Illustration 82 g03353104
Typical example

Table 8

Dimension	Description	76 mm (3 inch) tube
A	Clamp position from end of tube assembly	$1.5 \pm 1.5 \text{ mm}$ ($0.059 \pm 0.059 \text{ inch}$)
B	Outside diameter of tube assembly	$76.3 \pm 0.3 \text{ mm}$ ($3 \pm 0.01 \text{ inch}$)
-	Length to hold outside diameter of tube assembly in position	58 mm (2.28 inch)
C	Insertion of tube assembly	40 to 58 mm (1.57 to 2.28 inch)

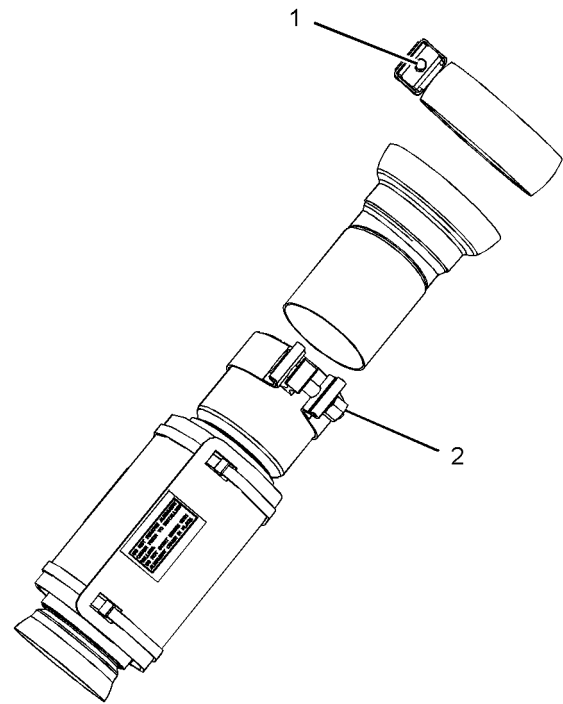

Illustration 83 g03353114
Typical example

Note: The minimum insertion depth should be marked on the tube assembly that will be used with the joint.

- (1) Tighten ball clamp to the following torque.
..... $35 \pm 2 \text{ N}\cdot\text{m}$ ($26 \pm 1 \text{ lb ft}$)
- (2) Tighten clamp to the following torque.
..... $55 \pm 8 \text{ N}\cdot\text{m}$ ($41 \pm 6 \text{ lb ft}$)

The flexible pipe incorporates several joints that allow for adjustment during installation. Two ball joints are used for angular adjustment. A slip joint is used for axial misalignment. A V-band clamp is used at the inlet connection of the aftertreatment.

The bellows is designed for a total displacement of plus or minus 6 mm (0.236 inch) in axial and lateral directions. This displacement is the sum of misalignment, thermal, and vibration displacement.

For remote installations in which the engine and aftertreatment are not supported from the same structure or where iso-mounts are used, use all the joints in the system to remove the static/assembly misalignment. This arrangement allows the full capability of the bellows to be used for dynamic movement.

The bellows will be supplied with a protective sleeve to maintain alignment during installation.

Note: Do not remove the protective sleeve until the installation of the flexible exhaust pipe is complete.

Note: The protective sleeve is not required where the aftertreatment is rigidly mounted to the engine. In this arrangement, the bellows will be used to account for static misalignment.

1. The lower exhaust tube assembly should be inserted into the bellows tube assembly (loose). The exhaust tube assembly should slide in without any excessive force having to be applied.
 2. Connect the lower exhaust tube assembly to the inlet connection of the aftertreatment with a V-band clamp.
 3. Position the upper tube between the bellows and the outlet connection of the turbocharger. Adjust the slip joint to ensure that there is good contact between the surfaces of the ball joints. Ensure that the ball joints are within the specified limit for misalignment.
 4. Verify that the cup of the ball joint does not touch the radius of the ball.
 5. Slide the ball clamp over the ball joint. Ensure that the edges of the ball clamp are equidistant and centered between the radiuses of the ball joint. Tighten the ball clamp hand tight.
 6. Align the remaining ball joints. Tighten the remaining ball clamps hand tight.
 7. Tighten the ball clamps to a torque of $35 \pm 2 \text{ N}\cdot\text{m}$ ($26 \pm 1 \text{ lb ft}$).
 8. Tighten V-band clamp to a torque of $12 \pm 1 \text{ N}\cdot\text{m}$ ($106 \pm 9 \text{ lb in}$).
- Note:** Ensure that the end of the exhaust tube assembly is not visible in the slot and the minimum insertion depth mark cannot be seen.
9. Tighten clamp to a torque of $55 \pm 8 \text{ N}\cdot\text{m}$ ($41 \pm 6 \text{ lb ft}$).
 10. Remove the protective sleeve.

Water Separator and Fuel Filter (Primary) for 854F-E34T Engines

The fuel filter (primary) has two inlet and two outlet ports.

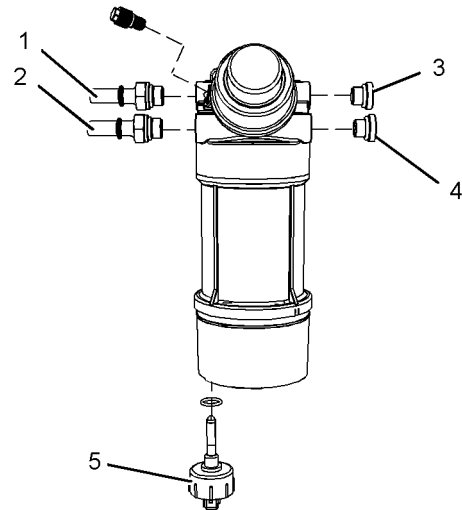

Illustration 84

g03228039

Typical example

Install connections (1) and (2). Tighten connections to a torque of $20 \pm 2 \text{ N}\cdot\text{m}$ ($177 \pm 18 \text{ lb in}$).

Install plugs (3) and (4). Tighten connections to a torque of $22.5 \pm 3.5 \text{ N}\cdot\text{m}$ ($199 \pm 31 \text{ lb in}$).

Tighten water in fuel sensor (5) to a torque of $2.5 \pm 0.25 \text{ N}\cdot\text{m}$ ($22 \pm 2.2 \text{ lb in}$).

Note: Tighten water in fuel sensor until the O-ring seal comes into contact with the bowl of the water separator. Tighten the water in fuel sensor an extra 180 degrees.

Electronic Control Module (ECM) and Wiring Harness Installation on 854F-E34T Engines

The Electronic Control Module (ECM) is supplied in a transit position on the engine. The customer installs the ECM on the application that is remote to the engine.

The customer must ensure that the correct ECM is matched to the correct engine. Ensure that the engine number on the ECM label is the same as the engine number on the engine emissions label.

Harness strain relief components must be positioned within 115 mm (4.5 inch) of each ECM connector.

The strain relief component must be mounted to the same surface as the ECM. The purpose of each strain relief is to prevent excessive movement between the connector, harness, and engine ECM.

Harness strain relief is required for both engine interface connectors.

The harness should be supported with brackets to prevent the mass of the harness straining the connectors.

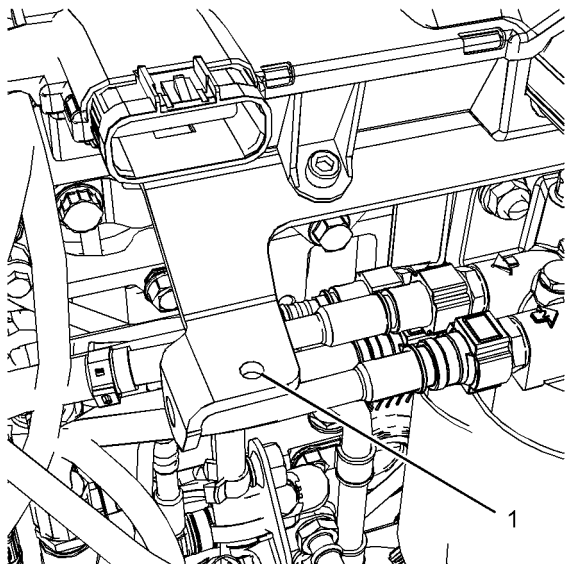

Illustration 85

g03240140

Typical example

Use of the clipping point (1), or other suitable clipping points, for harness paths should prevent undesirable movement and loads being applied to the connectors.

Flywheel for Certain 854F-E34T Engines

Customers that supply flywheels are required to use bolts sourced from the engine supplier and follow the defined assembly process.

Table 9

Required Tools			
Tool	Part Number	Part Description	Qty
A	-	Guide Stud M12 x 1.25 by 100mm	2
B	-	Angle Gauge	1

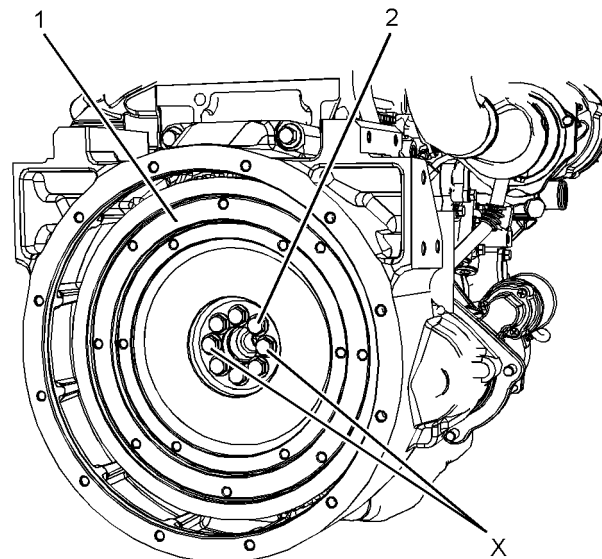

Illustration 86

g02659160

Typical example

1. Install a suitable lifting device to flywheel (1). The flywheel can weigh 55 kg (121 lb).
2. Install Tooling (A) in Position (X) on the crankshaft.
3. Use the suitable lifting device to position flywheel (1) onto Tooling (A).
4. Install new bolts (2) hand tight to flywheel (1).
5. Remove Tooling (A) and install remaining new bolts (2) hand tight to flywheel (1).
6. Remove the lifting device from flywheel (1).
7. Use a suitable tool to prevent the flywheel from rotating. Tighten bolts (2) to a torque of $30 \pm 1.5 \text{ N}\cdot\text{m}$ ($266 \pm 13 \text{ lb in}$). Use Tooling (B) to rotate bolts (2) through an extra 90 degrees in a clockwise direction to achieve the required final torque.

Alignment of the Flywheel Face

Table 10

Required Tools			
Tool	Part Number	Part Description	Qty
A	-	Dial Indicator	1

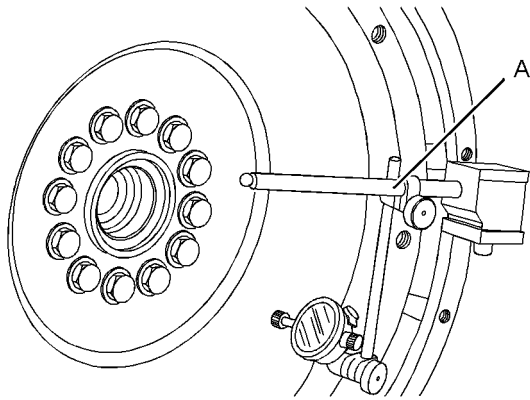

Illustration 87

g01334421

Typical example

1. Install Tooling (A) in illustration 87, as shown.
 2. Set the pointer of the dial indicator to 0 mm (0 inch).
 3. Turn the flywheel. Read the dial indicator for every 45 degrees.
- Note:** During the check, keep the crankshaft pressed toward the front of the engine to remove any end play.
4. Calculate the difference between the lowest measurement and the highest measurement of the four locations. This difference must not be greater than 0.03 mm (0.001 inch) for every 25 mm (1.0 inch) of the radius of the flywheel. The radius of the flywheel is measured from the axis of the crankshaft to the contact point of the dial indicator.

Flywheel Runout

Table 11

Required Tools			
Tool	Part Number	Part Description	Qty
A	-	Dial Indicator	1

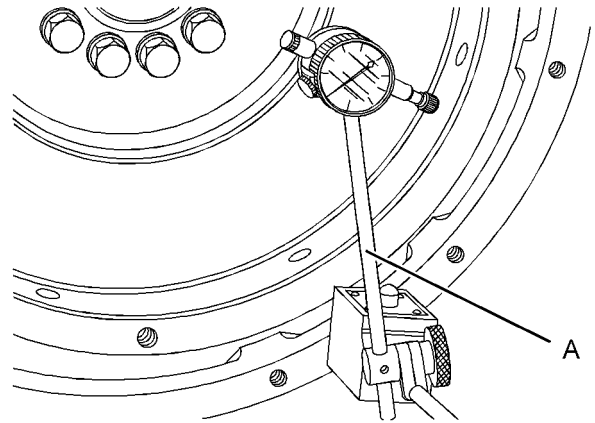

Illustration 88

g01334422

Typical example

1. Install Tooling (A) in illustration 88, as shown.
2. Set the pointer of the dial indicator to 0 mm (0 inch).
3. Turn the flywheel. Read the dial indicator for every 45 degrees.
4. Calculate the difference between the lowest measurement and the highest measurement of the four locations. This difference must not be greater than 0.30 mm (0.012 inch).

Alignment of the Flywheel Face

Table 12

Required Tools			
Tool	Part Number	Part Description	Qty
A	-	Dial Indicator	1

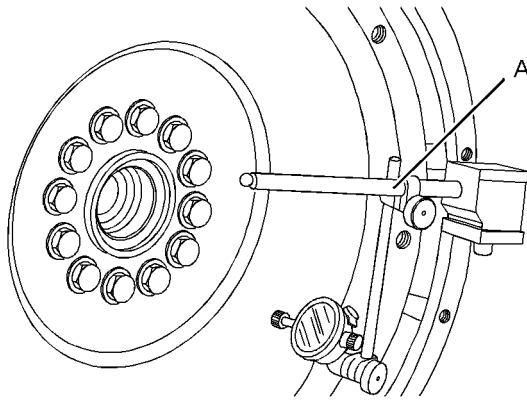

Illustration 89

g01334421

Typical example

1. Install Tooling (A) in illustration 87, as shown.
 2. Set the pointer of the dial indicator to 0 mm (0 inch).
 3. Turn the flywheel. Read the dial indicator for every 45 degrees.
- Note:** During the check, keep the crankshaft pressed toward the front of the engine to remove any end play.
4. Calculate the difference between the lowest measurement and the highest measurement of the four locations. This difference must not be greater than 0.03 mm (0.001 inch) for every 25 mm (1.0 inch) of the radius of the flywheel. The radius of the flywheel is measured from the axis of the crankshaft to the contact point of the dial indicator.

Flywheel Runout

Table 13

Required Tools			
Tool	Part Number	Part Description	Qty
A	-	Dial Indicator	1

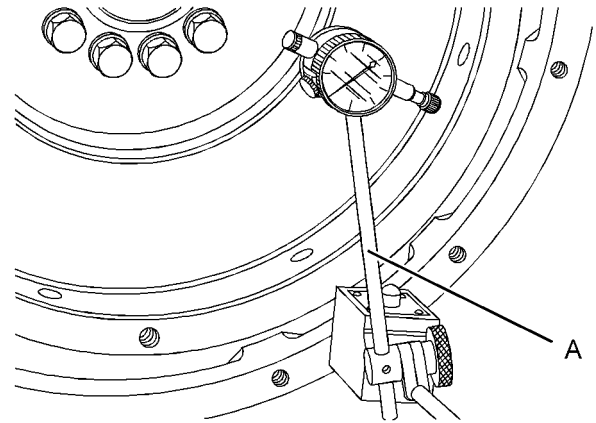

Illustration 90

g01334422

Typical example

1. Install Tooling (A) in illustration 88, as shown.
2. Set the pointer of the dial indicator to 0 mm (0 inch).
3. Turn the flywheel. Read the dial indicator for every 45 degrees.
4. Calculate the difference between the lowest measurement and the highest measurement of the four locations. This difference must not be greater than 0.30 mm (0.012 inch).

Electric Starting Motor on Certain 854F-E34T Engines

In certain instances, the customer may need to install the electric starting motor to the engine.

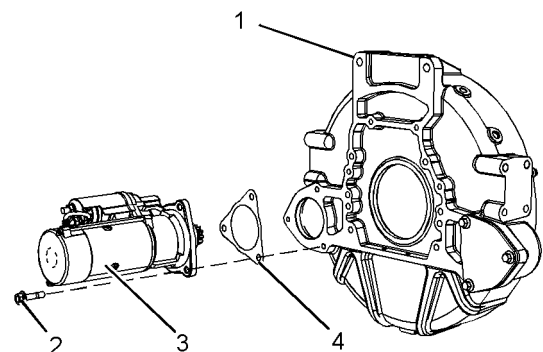

Illustration 91

g02844537

Typical example

1. If necessary, position a new gasket (4) onto electric starting motor (3).

2. Position electric starting motor (3) onto flywheel housing (1).

Note: Ensure that the electric starting motor is seated correctly in the starter motor pocket.

3. Install bolts (2) to electric starting motor (3). Tighten the bolts to a torque of $45 \pm 4.5 \text{ N}\cdot\text{m}$ ($33 \pm 3 \text{ lb ft}$)
4. Connect the harness assembly to the electric starting motor and the solenoid.

Installation of Alternator and Fan Belts on 854F-E34T Engines

In certain instances, the customer may need to install the alternator and fan belts to the engine.

If the customer is receiving engines with different fan pulley diameters and is installing belts of different lengths, the customer must be able to demonstrate that a belt of correct length is being assembled to an individual engine.

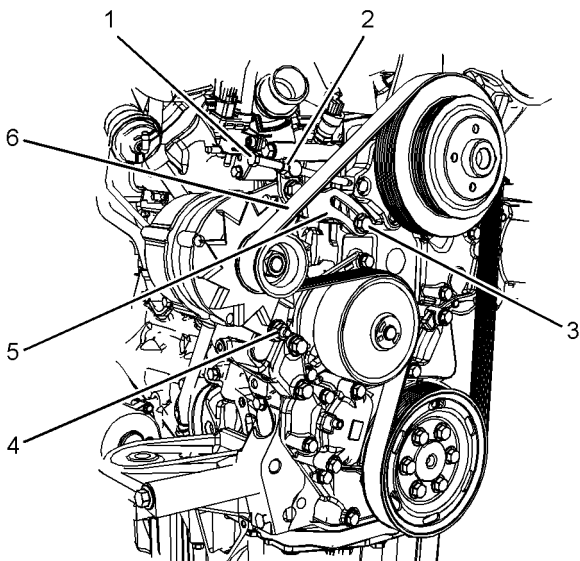

Illustration 92

g02553437

Typical example

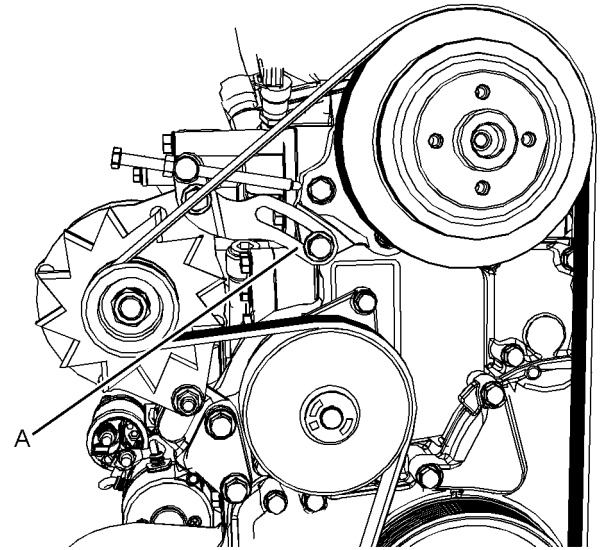

Illustration 93

g02553697

Typical example

1. Ensure that the pulleys and guide rollers are free from dirt debris, and paint.
2. Install new alternator belt (6) onto pulleys. Ensure that the alternator belt is centered on all pulleys.

Note: The ribs on the alternator belt must be located into the grooves of all pulleys.

3. Tighten bolt (1) until adjusting bracket (5) has reached the full extent of the available adjustment in Position (A).
4. Tighten bolt (3) to a torque of $50 \pm 5 \text{ N}\cdot\text{m}$ ($37 \pm 4 \text{ lb ft}$).
5. Tighten nut and bolt (4) to a torque of $50 \pm 5 \text{ N}\cdot\text{m}$ ($37 \pm 4 \text{ lb ft}$).
6. Rotate tensioning bolt (1) two complete revolutions in a counterclockwise direction. Tighten locking nut (2) to a torque of $30 \pm 3 \text{ N}\cdot\text{m}$ ($266 \pm 27 \text{ lb in}$).

Air Compressor Bracket Installation for 854F-E34T Engines

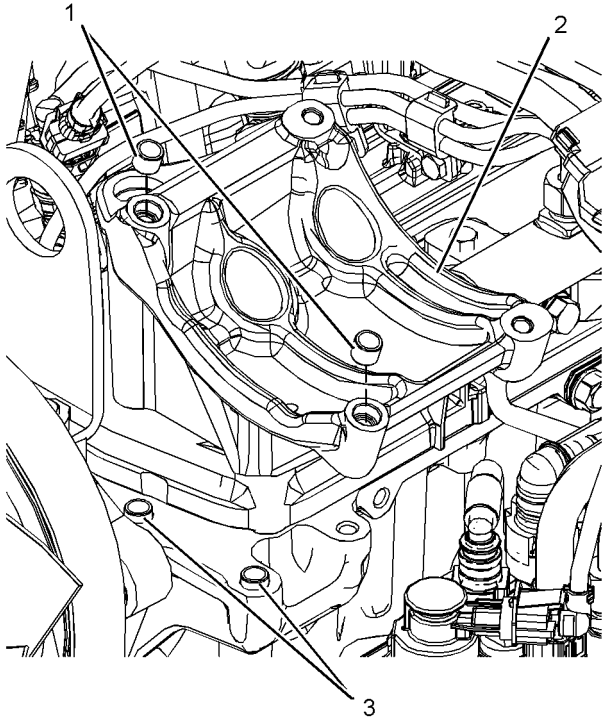

Illustration 94

g03237745

Typical example

Air compressor bracket is supplied with two dowels (1) installed.

Two more dowels are supplied which can be used to align air compressor to the bracket.

The air compressor is supplied by the OEM.

Note: The two dowels (3) on the rear of the bracket (2) must not be removed to ensure alignment to front left corner of the cylinder head.

Power Take-Off Drive for 854F-E34T Engines

There are two options to install driven equipment to the power take-off drive. The first option installs the driven equipment to the power take-off drive on the engine. The second option requires the power take-off drive to be removed. The driven equipment is then installed on the power take-off drive. The power take-off drive is then installed on the engine.

Installation of Driven Equipment to the Power Take-Off Drive Without the Removal of the Power Take-Off Drive from the Engine

NOTICE

Keep all parts clean from contaminants.

Contaminants may cause rapid wear and shortened component life.

NOTICE

Care must be taken to ensure that fluids are contained during performance of inspection, maintenance, testing, adjusting and repair of the product. Be prepared to collect the fluid with suitable containers before opening any compartment or disassembling any component containing fluids.

Dispose of all fluids according to local regulations and mandates.

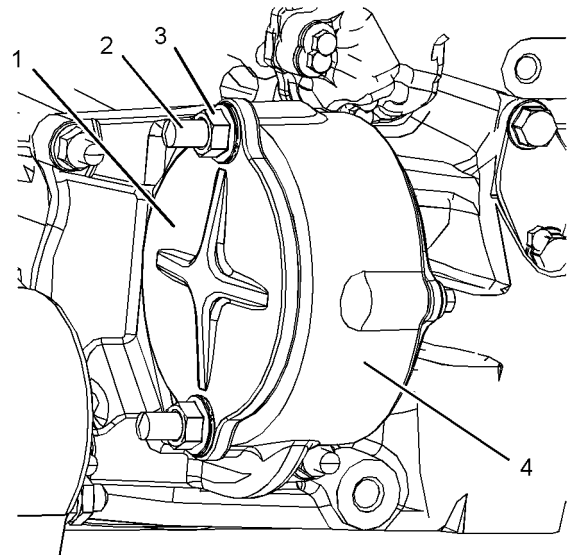

Illustration 95

g03238156

Typical example

Installation of Driven Equipment to the Power Take-Off Drive With the Removal of the Power Take-Off Drive from the Engine

NOTICE

Keep all parts clean from contaminants.

Contaminants may cause rapid wear and shortened component life.

NOTICE

Care must be taken to ensure that fluids are contained during performance of inspection, maintenance, testing, adjusting and repair of the product. Be prepared to collect the fluid with suitable containers before opening any compartment or disassembling any component containing fluids.

Dispose of all fluids according to local regulations and mandates.

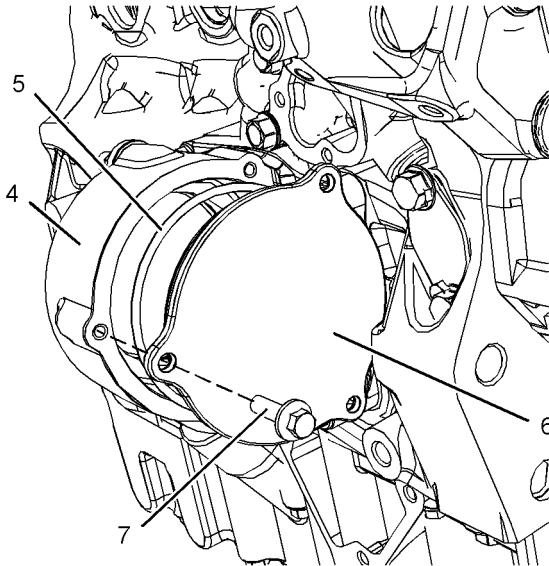

Illustration 96

g03238159

Typical example

1. Remove nuts (3) from power take-off drive (5).
2. Remove cover (1) from power take-off drive (4). Discard cover (1).
3. Remove O-ring seal (not shown) from power take-off drive (4). Discard O-ring seal.
4. Remove bolts (7) from power take-off drive (4).
5. Remove cover (6) from power take-off drive (4).
6. Remove O-ring seal (5) from power take-off drive (4). Discard O-ring seal.
7. Install the driven equipment to studs (2).
8. Install nuts (3) to studs (2). Tighten nuts to a torque of $45 \pm 3 \text{ N}\cdot\text{m}$ ($33 \pm 2 \text{ lb ft}$).
9. Install the gear to the driven equipment. Ensure that the gears are engaged. Tighten the nut for the gear to the correct torque.
10. Install new O-ring seal (5) to power take-off drive (4).
11. Install cover (6) to power take-off drive (4). Install bolts (7) to power take-off drive (4). Tighten bolts to a torque of $10 \pm 1 \text{ N}\cdot\text{m}$ ($89 \pm 9 \text{ lb in}$).

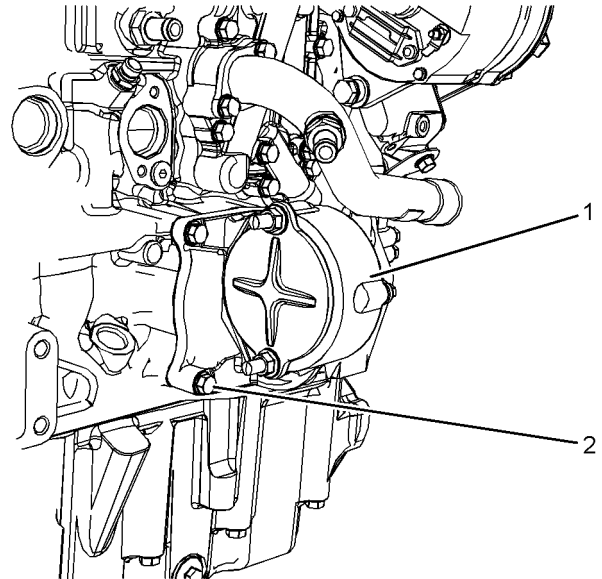

Illustration 97

g02901518

Typical example

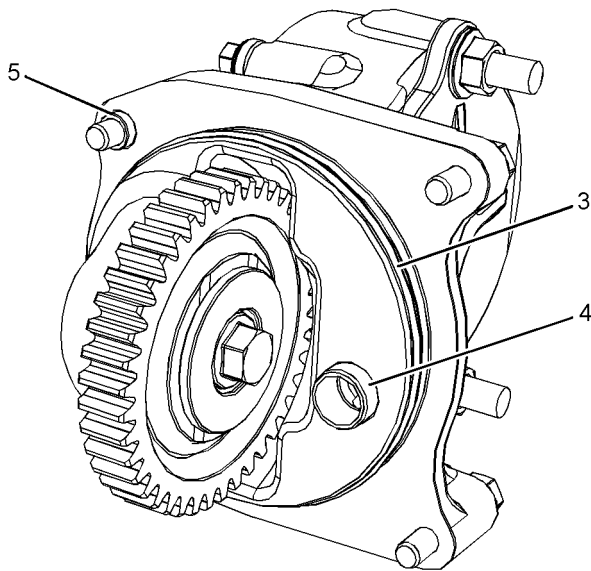

Illustration 98

g02901685

Typical example

1. Remove nuts (2) from power take-off drive (1).
2. Remove the power take-off drive (1) from the cylinder block.
3. Remove O-ring seal (3) from power take-off drive (1).
4. Note the position of dowel (4) and dowel (5) in the power take-off drive. Do not remove the dowels unless the dowels are damaged.

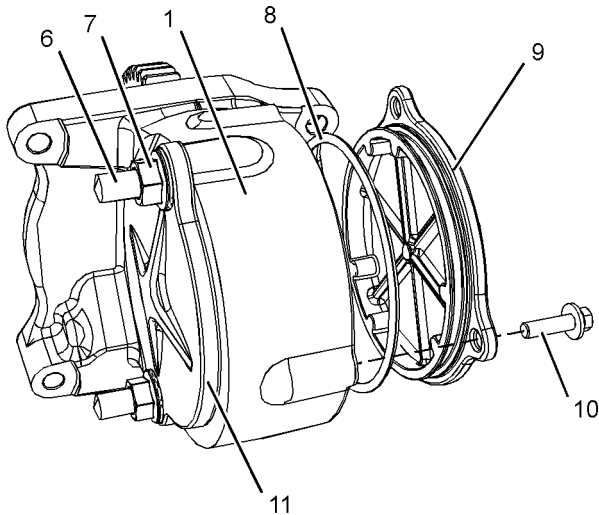

Illustration 99

g03240056

Typical example

5. Remove nuts (7) from power take-off drive (1).
6. Remove cover (11) from power take-off drive (1). Discard cover (11).

7. Remove O-ring seal (not shown) from power take-off drive (1). Discard O-ring seal.
8. Remove bolts (10) from power take-off drive (1).
9. Remove cover (9) from power take-off drive (1).
10. Remove O-ring seal (8) from power take-off drive (1). Discard O-ring seal.
11. Install the driven equipment to studs (6).
12. Install nuts (7) to studs (6). Tighten nuts to a torque of $45 \pm 3 \text{ N}\cdot\text{m}$ ($33 \pm 2 \text{ lb ft}$).
13. Install the gear to the driven equipment. Ensure that the gears are engaged. Tighten the nut for the gear to the correct torque.
14. Install new O-ring seal (8) to power take-off drive (1).
15. Install cover (9) to power take-off drive (1). Install bolts (10) to power take-off drive (1). Tighten bolts to a torque of $10 \pm 1 \text{ N}\cdot\text{m}$ ($89 \pm 9 \text{ lb in}$).
16. If necessary, install dowel (4) and dowel (5) into power take-off drive (1).
17. Install a new O-ring seal (3) onto power take-off drive (1).
18. Position power take-off drive (1) onto the cylinder block.
19. Equally tighten bolts (2) to pull power take-off drive (1) into the cylinder block
20. Tighten nuts (2) to a torque of $35 \pm 3 \text{ N}\cdot\text{m}$ ($26 \pm 2 \text{ lb ft}$)
21. Ensure that there is tactile backlash between the idler gear and the accessory drive gear.

Note: Ensure that the drive gear for the power take-off drive is correctly engaged with the gear on the crankshaft.

If the customer has used this process, the customer must maintain a record of assembly with the following information:

- Engine serial number
- Machine serial number
- Technician
- Date

Note: A visual inspection should be undertaken to check for oil leaks from all joint faces.

Oxygen Sensor for 854F-E34T Engines

Table 14

Required Tools			
Tool	Part Number	Part Description	Qty
A	-	Bostik Pure Nickel Anti-Seize Compound	1

NOTICE

Keep all parts clean from contaminants.

Contaminants may cause rapid wear and shortened component life.

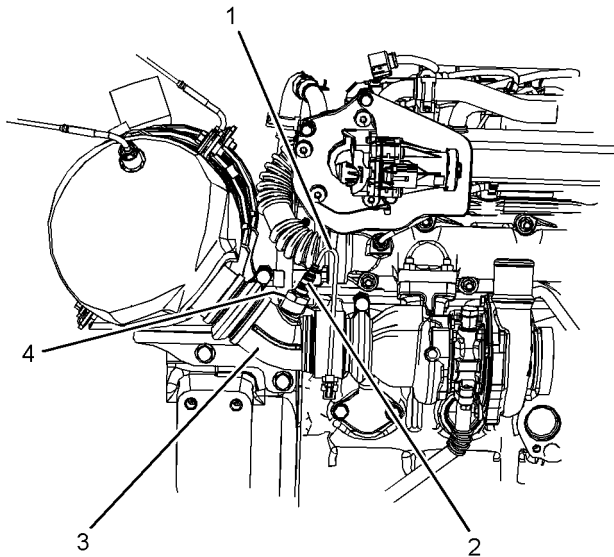

Illustration 100

g02725166

1. If necessary, install a new sealing washer (4) (not shown) to oxygen sensor (2).
2. Apply Tooling (A) to the threads of oxygen sensor (4) (not shown).
3. Install oxygen sensor (2) to exhaust tube assembly (3). Tighten the oxygen sensor to a torque of $50 \pm 5 \text{ N}\cdot\text{m}$ ($37 \pm 4 \text{ lb ft}$).
4. Connect harness assembly (1).

Note: The bend radius for the harness assembly must be more than 20 mm (0.80 inch).

Note: The bend radius for the grommet must be more than 12 mm (0.47 inch).

Temperature Sensor (DPF) for 854F-E34T Engines

All Diesel Particulate Filters (DPFs) require Diesel Oxidation Catalyst (DOC) inlet and outlet temperature sensors.

All remote DPFs will have the temperature sensors supplied loose.

Note: If the DPF is supplied assembled to engine, the temperature sensors are pre-installed.

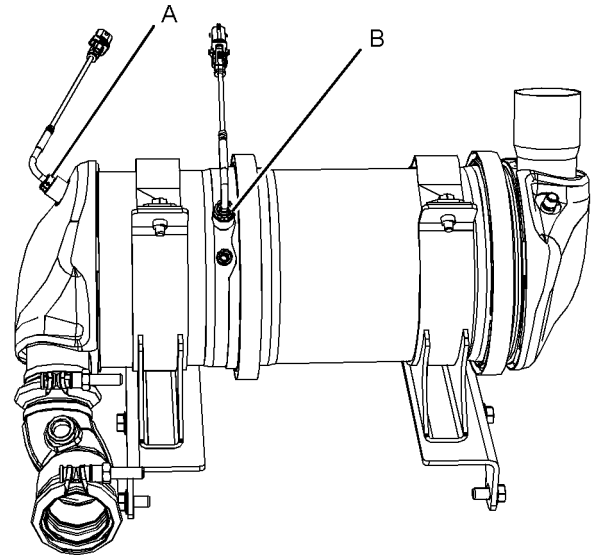

Illustration 101

g03237176

Typical example

- (A) Inlet temperature sensor
(B) Outlet temperature sensor

For both through flow and wall flow DPFs the inlet temperature sensors have a black electrical connector, the outlet sensor has a white electrical connector. Both through flow and wall flow DPFs use the same sensors.

Table 15

Required Tools			
Tool	Part Number	Part Description	Qty
A	-	Bostik Pure Nickel Anti-Seize Compound	1

1. Ensure that all components are clean and free from wear and damage. If necessary, replace any components that are worn or damaged.

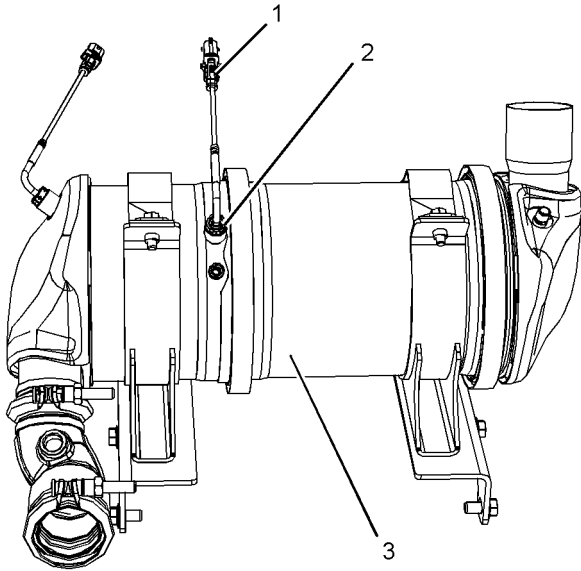

Illustration 102

g02728556

Typical example

2. Use tooling (A) to lubricate the thread of temperature sensor (2).
 3. Install temperature sensor (2) to DPF (3). Tighten temperature sensor to a torque of $45 \pm 5 \text{ N}\cdot\text{m}$ ($33 \pm 4 \text{ lb ft}$)
- Note:** Ensure correct positioning of the temperature sensor.
4. Connect harness assembly (1).
 5. If necessary, repeat Step 2 through Step 4 to install the remaining temperature sensor to the DPF.

Differential Pressure Sensor for 854F-E34T Engines

Note: The pipe length or hose length from pressure point on DPF to sensor must rise continuously to avoid condensation ingress into the sensor.

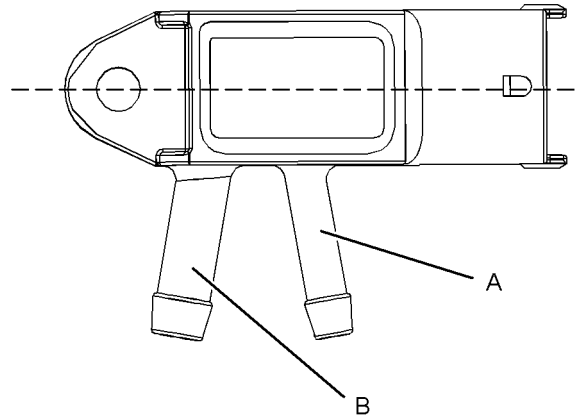

Illustration 103

g03237917

Typical example

Note: The sensor pipe ports should point downwards. The sensor must not exceed plus or minus 15 degrees from the horizontal.

The vertical pressure port (A) is connected to DPF inlet side (identified by the larger diameter connection).

The pressure port (B) is connected to DPF outlet side.

Painting of the 854F-E34T Engine

Painting of the Main Engine Components

Customers are permitted to paint the engine as received or as part of a power train sub assembly. These engines are supplied in gray primer.

The customer must not paint the Diesel Particulate Filter (DPF), Electronic Control Module (ECM), starting motor, alternator, belts, or the glow plug control unit.

The customer must use suitable plugs and masks to an equivalent standard to the engine assembly plant.

The customer must prevent water ingress into the engine by maintaining an equivalent plugging standard to the engine assembly plant.

Electrostatic Painting of the Engine

The Electronic Control Module (ECM), sensors and other electronic components are not proven to be compatible with electrostatic painting. Perkins does not recommend use of electrostatic painting on the engine or ECM.

Engine Labels for 854F-E34T Engines

All engines are supplied with a loose right-hand side universal warning label for customer installation.

The total number of labels supplied with an engine may include:

- Right-hand side universal warning label
- Oil type label for the oil filler cap
- Valve mechanism cover branding plate
- Duplicate emission label

Note: All universal warning labels (where not installed) must be placed in a visible location on or close to the engine.

Note: All other labels must be installed in the designated locations.

Note: A duplicate emissions label is supplied loose with the engine if a written request has been submitted.

The emission labels installed to the engine have a clear top masking film. This masking film does not always perform well in the customer paint process. The customer may wish to paint over the installed emissions label with the intention of installing the duplicate label in the same location. The film on the label installed to the engine must be removed prior to the engine being painted by the customer. When the duplicate label is applied, full tamperproof properties are achieved.

Engine Lubricating Oil Recommendations

NOTICE

Perkins require the use of the following specification of engine oil. Failure to use the appropriate specification of engine oil will reduce the life of your engine. Failure to use the correct specification of engine will also reduce the life and the effectiveness of your aftertreatment system.

Table 16

API Classifications for the Industrial Engine
Oil Specification
ECF-3 CJ-4 AECA E9

Note: Ensure that the correct oil type label is applied to the oil filler cap.

Coolant Recommendations

The following two coolants are used in Perkins diesel engines:

Preferred – Perkins ELC (Extended Life Coolant).

Acceptable – A Perkins DEAC (Diesel Engine Antifreeze/Coolant) or a commercial heavy-duty antifreeze that meets “ASTM D6210” specifications

NOTICE

The Perkins industrial engine must be operated with a 1:1 mixture of water and glycol. This concentration allows the NOx reduction system to operate correctly at high ambient temperatures.

Perkins recommends a 1:1 mixture of water and glycol. This mixture of water and glycol will provide optimum heavy-duty performance as an antifreeze.

Ensure that the coolant fill rate meets the recommended coolant fill rate for the application.

Glow Plug Control Unit for 854F-E34T Engines

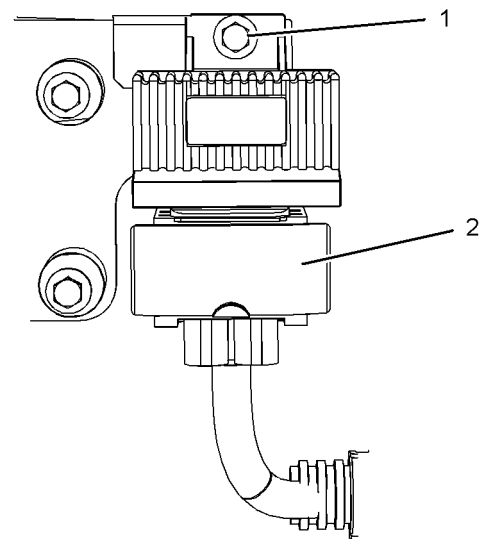

Illustration 104

g03350062

Typical example

Note: Ensure that the glow plug control unit is in a vertical position.

Tighten the setscrew (1) to a torque of $8 \pm 1 \text{ N}\cdot\text{m}$ ($71 \pm 9 \text{ lb in}$).

Install the harness to the glow plug control unit.

Heater Connections for Operators Enclosure for 854F-E34T Engines

If heaters are supplied by the engine manufacturer, tighten the bolts to a torque of 40 ± 4 N·m (30 ± 3 lb ft).

Heater Connection for Crankcase Breather for 854F-E34T Engines

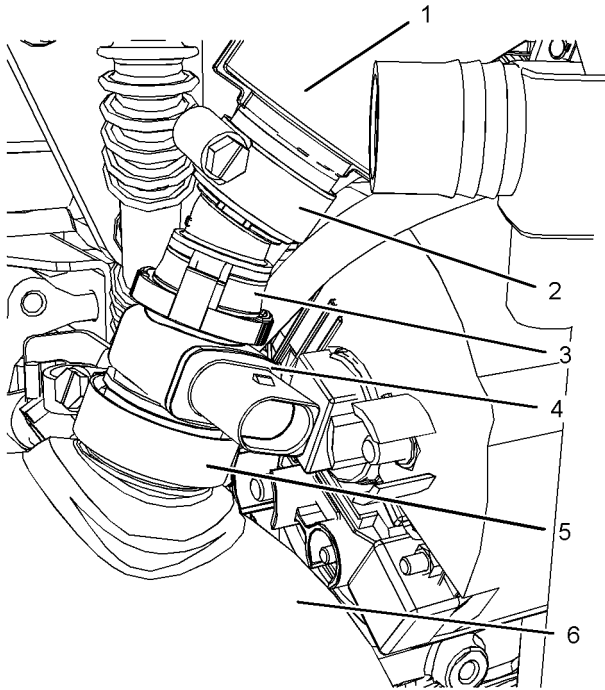

Illustration 105

g03240717

Typical example

1. Install clamp (5) to pipe (6).
2. Install heater connection (4) to pipe (6).
3. Install hose connector (3) to heater connection (4).
4. Install clamp (2) to hose (1).
5. Install hose (1) to hose connector (3).
6. Tighten the clamps (2) and (5) to a torque of 5 ± 1 N·m (44 ± 9 lb in).

Auxiliary Crankshaft Pulley for 854F-E34T Engines

NOTICE

Keep all parts clean from contaminants.

Contaminants may cause rapid wear and shortened component life.

1. Ensure that all components are clean and free from wear and damage. If necessary, replace any components that are free from wear and damage.

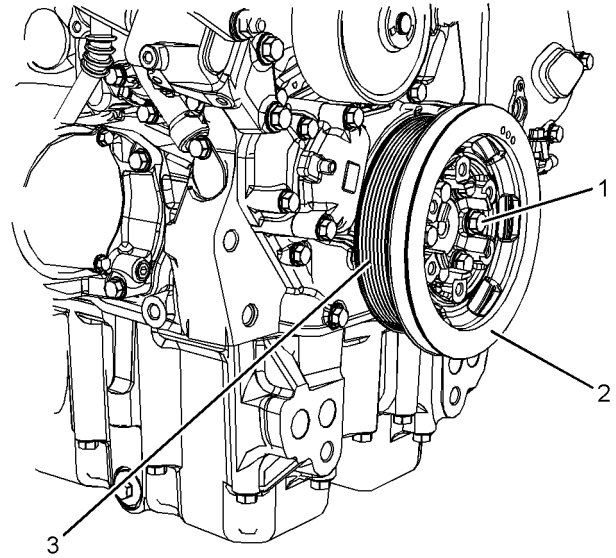

Illustration 106

g02926996

2. Install crankshaft multi V-pulley (3) onto the crankshaft.
3. Install crankshaft V-pulley (2).
4. Install bolts (1) to the crankshaft pulley. Tighten the bolts to a torque of 45 ± 4.5 N·m (33 ± 3 lb ft)

Note: Use a suitable method to prevent the crankshaft from rotating when torquing the bolts.

Hydraulic Pump Drive Adaptor for 854F-E34T Engines

Table 17

Required Tools			
Tool	Part Number	Part Description	Qty
A	-	Delphi Lockheed Compound Rubber Grease	1

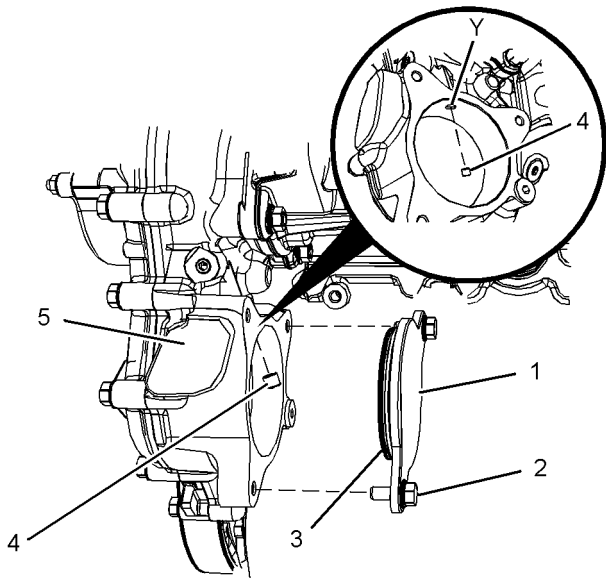

Illustration 107

g03350448

Typical example

1. If necessary, follow Step 1.a through Step 1.c to remove cover plate (1) from the front housing (5).
 - a. Remove bolts (2) from cover plate (1).
 - b. Remove cover plate (1) from front housing (5).
 - c. Remove O-ring seal (3) from the cover plate.
2. Remove plug (4) in Position (Y) from the front housing.

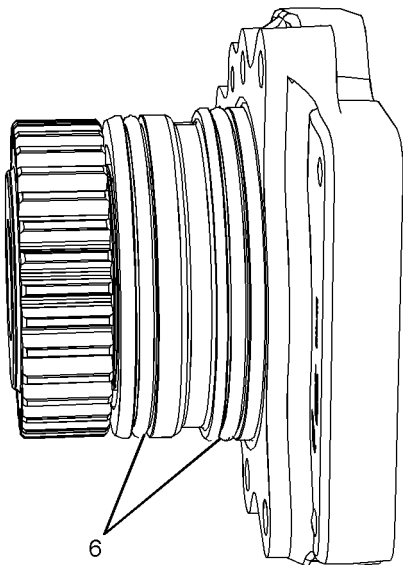

Illustration 108

g03350457

Typical example

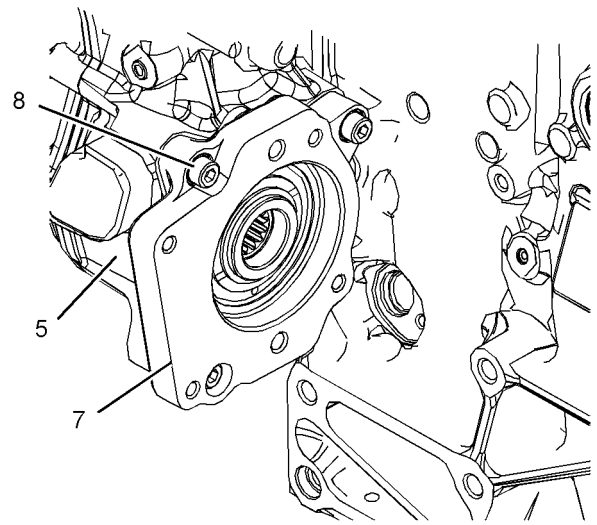

Illustration 109

g03350460

Typical example

3. If necessary, install new O-ring seals (6) onto accessory drive (7).
4. Apply Tooling (A) onto O-ring seals (6).
5. Install accessory drive (7) to housing (5).
6. Install Allen head bolts (8) to accessory drive (7).
7. Equally tighten the Allen head bolts (8) to pull accessory drive (7) into housing (5).
8. Tighten Allen head bolts to a torque of $25 \pm 2.5 \text{ N}\cdot\text{m}$ ($221 \pm 22 \text{ lb in}$).
9. Ensure that there is tactile backlash between the idler gear and the accessory drive gear.
10. Install the OEM driven equipment to accessory drive (7). Refer to the OEM for the correct procedure.

■

