

# WSM

---

## WORKSHOP MANUAL **DIESEL ENGINE**

### **V3300-E2B, V3300-T-E2B**

---

# Kubota

# TO THE READER

This Workshop Manual has been prepared to provide servicing personnel with information on the mechanism, service and maintenance of V3300-E2B, V3300-T-E2B. It is divided into three parts, "General", "Mechanism" and "Servicing".

## ■ General

Information on the engine identification, the general precautions, maintenance check list, check and maintenance and special tools are described.

## ■ Mechanism

Information on the construction and function are included. This part should be understood before proceeding with troubleshooting, disassembling and servicing.

Refer to Diesel Engine Mechanism Workshop Manual (Code No. 9Y021-01870) for the one which has not been described to this workshop manual.

## ■ Servicing

Information on the troubleshooting, servicing specification lists, tightening torque, checking and adjusting, disassembling and assembling, and servicing which cover procedures, precautions, factory specifications and allowable limits.

All information illustrations and specifications contained in this manual are based on the latest product information available at the time of publication.

The right is reserved to make changes in all information at any time without notice.

Due to covering many models of this manual, information or picture being used have not been specified as one model.

**March 2004**

© KUBOTA Corporation 2004



## SAFETY FIRST

This symbol, the industry's "Safety Alert Symbol", is used throughout this manual and on labels on the machine itself to warn of the possibility of personal injury. Read these instructions carefully.

It is essential that you read the instructions and safety regulations before you attempt to repair or use this unit.



### DANGER

: Indicates an imminently hazardous situation which, if not avoided, will result in death or serious injury.



### WARNING

: Indicates a potentially hazardous situation which, if not avoided, could result in death or serious injury.



### CAUTION

: Indicates a potentially hazardous situation which, if not avoided, may result in minor or moderate injury.



### IMPORTANT

: Indicates that equipment or property damage could result if instructions are not followed.



### NOTE

: Gives helpful information.

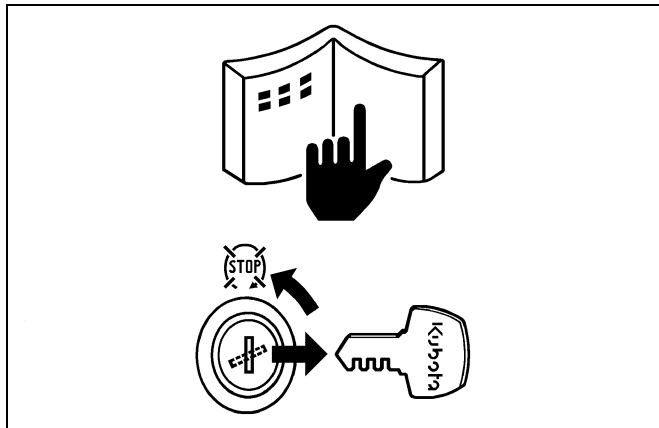

### BEFORE SERVICING AND REPAIRING

- Read all instructions and safety instructions in this manual and on your engine safety decals.
- Clean the work area and engine.
- Park the machine on a firm and level ground.
- Allow the engine to cool before proceeding.
- Stop the engine, and remove the key.
- Disconnect the battery negative cable.
- Hang a "**DO NOT OPERATE**" tag in operator station.

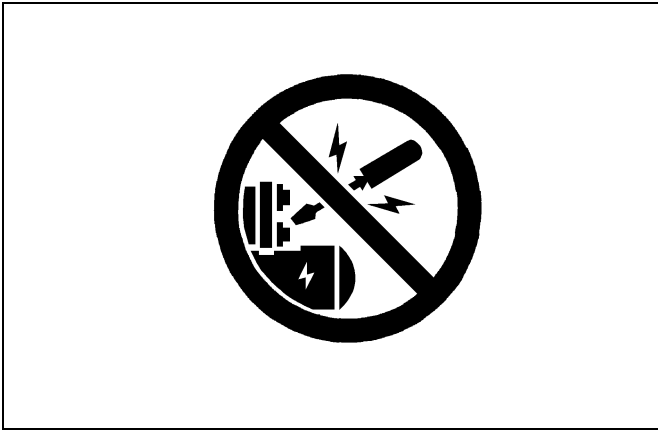

### SAFETY STARTING

- Do not start the engine by shorting across starter terminals or bypassing the safety start switch.
- Unauthorized modifications to the engine may impair the function and / or safety and affect engine life.

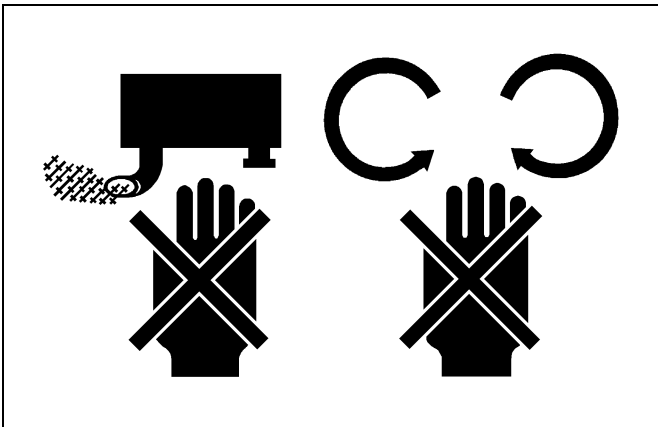

### SAFETY WORKING

- Do not work on the machine while under the influence of alcohol, medication, or other substances or while fatigued.
- Wear close fitting clothing and safety equipment appropriate to the job.
- Use tools appropriate to the work. Makeshift tools, parts, and procedures are not recommended.
- When servicing is performed together by two or more persons, take care to perform all work safely.
- Do not touch the rotating or hot parts while the engine is running.
- Never remove the radiator cap while the engine is running, or immediately after stopping. Otherwise, hot water will spout out from radiator. Only remove radiator cap when cool enough to touch with bare hands. Slowly loosen the cap to first stop to relieve pressure before removing completely.
- Escaping fluid (fuel or hydraulic oil) under pressure can penetrate the skin causing serious injury. Relieve pressure before disconnecting hydraulic or fuel lines. Tighten all connections before applying pressure.
- Wear a suitable hearing protective device such as earmuffs or earplugs to protect against objectionable or uncomfortable loud noises.

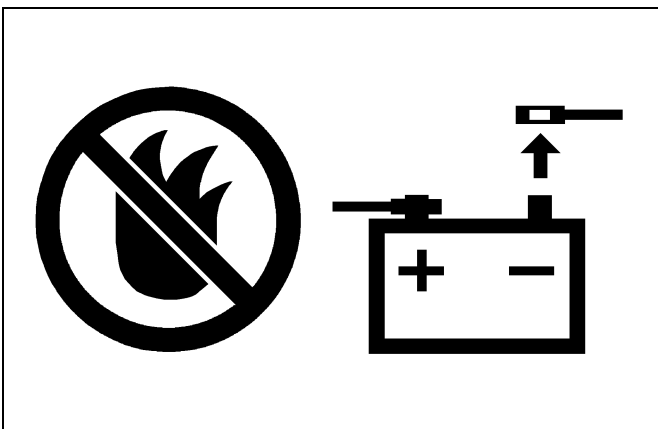
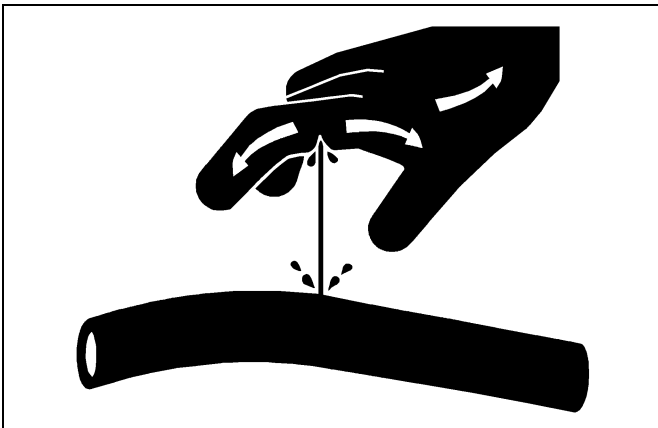

### AVOID FIRES

- Fuel is extremely flammable and explosive under certain conditions. Do not smoke or allow flames or sparks in your working area.
- To avoid sparks from an accidental short circuit, always disconnect the battery negative cable first and connect it last.
- Battery gas can explode. Keep sparks and open flame away from the top of battery, especially when charging the battery.
- Make sure that no fuel has been spilled on the engine.

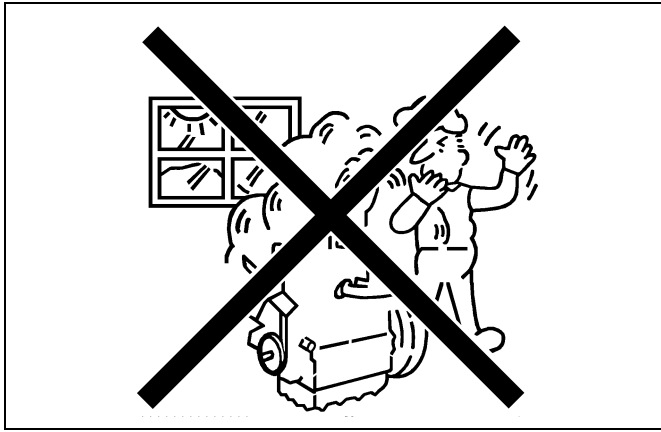

### VENTILATE WORK AREA

- If the engine must be running to do some work, make sure the area is well ventilated. Never run the engine in a closed area. The exhaust gas contains poisonous carbon monoxide.

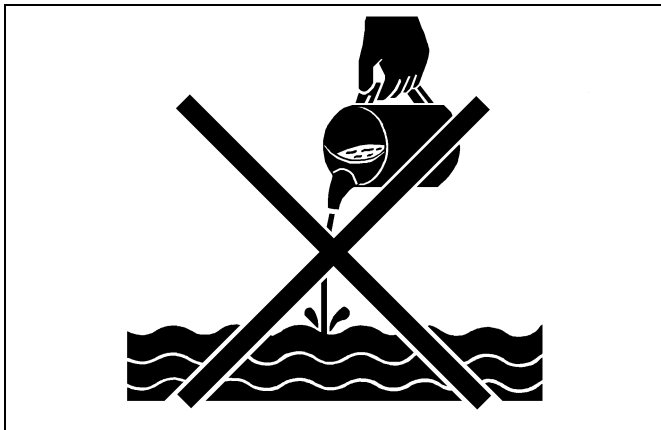

### DISPOSE OF FLUIDS PROPERLY

- Do not pour fluids into the ground, down a drain, or into a stream, pond, or lake. Observe relevant environmental protection regulations when disposing of oil, fuel, coolant, electrolyte and other harmful waste.

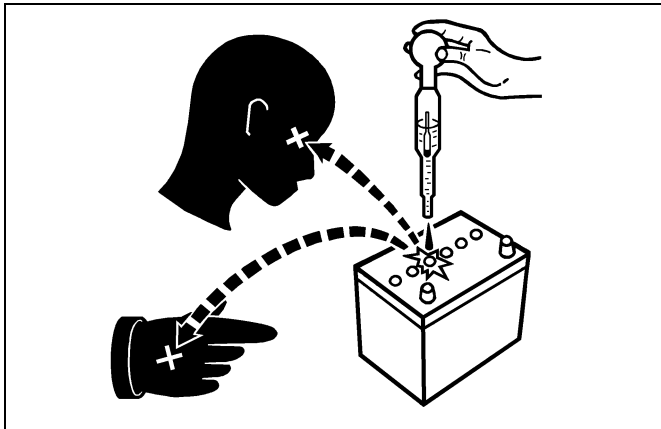

### PREVENT ACID BURNS

- Sulfuric acid in battery electrolyte is poisonous. It is strong enough to burn skin, clothing and cause blindness if splashed into eyes. Keep electrolyte away from eyes, hands and clothing. If you spill electrolyte on yourself, flush with water, and get medical attention immediately.

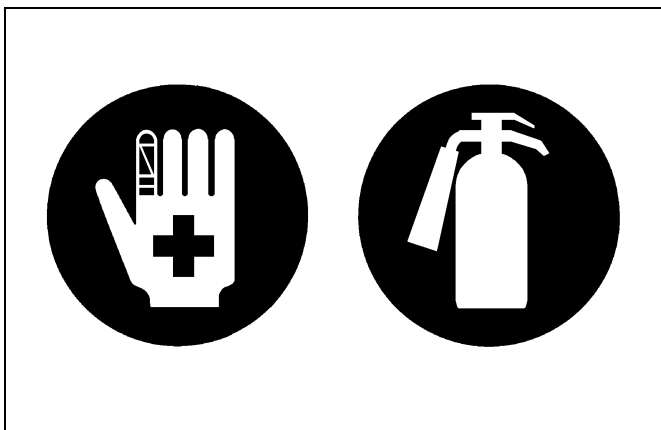

### PREPARE FOR EMERGENCIES

- Keep a first aid kit and fire extinguisher handy at all times.
- Keep emergency numbers for doctors, ambulance service, hospital and fire department near your telephone.

# SPECIFICATIONS

Model	V3300-E2B	V3300-T-E2B
Number of Cylinder	4	
Type	Vertical, water-cooled, 4-cycle diesel engine	
Bore × Stroke	98 × 110 mm (3.86 × 4.33 in.)	
Total Displacement	3318 cm <sup>3</sup> (202.48 cu.in.)	
ISO Net Continuous	44.1 kW / 2600 min <sup>-1</sup> (rpm) (59.1 HP / 2600 min <sup>-1</sup> (rpm))	53.8 kW / 2600 min <sup>-1</sup> (rpm) (72.1 HP / 2600 min <sup>-1</sup> (rpm))
ISO / SAE Net Intermittent	50.7 kW / 2600 min <sup>-1</sup> (rpm) (68.0 HP / 2600 min <sup>-1</sup> (rpm))	61.9 kW / 2600 min <sup>-1</sup> (rpm) (83.0 HP / 2600 min <sup>-1</sup> (rpm))
SAE Gross Intermittent	54.5 kW / 2600 min <sup>-1</sup> (rpm) (73.0 HP / 2600 min <sup>-1</sup> (rpm))	65.2 kW / 2600 min <sup>-1</sup> (rpm) (87.4 HP / 2600 min <sup>-1</sup> (rpm))
DIN6271-NA	44.6 kW / 2600 min <sup>-1</sup> (rpm) (59.8 ps / 2600 min <sup>-1</sup> (rpm))	53.8 kW / 2600 min <sup>-1</sup> (rpm) (73.1 ps / 2600 min <sup>-1</sup> (rpm))
DIN6271-NB	48.9 kW / 2600 min <sup>-1</sup> (rpm) (66.5 ps / 2600 min <sup>-1</sup> (rpm))	59.7 kW / 2600 min <sup>-1</sup> (rpm) (81.2 ps / 2600 min <sup>-1</sup> (rpm))
DIN70020	52.7 kW / 2600 min <sup>-1</sup> (rpm) (71.7 ps / 2600 min <sup>-1</sup> (rpm))	64.4 kW / 2600 min <sup>-1</sup> (rpm) (87.6 ps / 2600 min <sup>-1</sup> (rpm))
Maximum Bare Speed	2800 min <sup>-1</sup> (rpm)	
Minimum Bare Idling Speed	700 to 750 min <sup>-1</sup> (rpm)	
Combustion Chamber	Spherical Type (E-TVCS)	
Fuel Injection Pump	Bosch Type Mini Pump	
Governor	All speed mechanical governor	
Direction of Rotation	Counter-clockwise (Viewed from flywheel side)	
Injection Nozzle	BOSCH Throttle-Type	
Injection Timing	0.21 rad. (12 °) before T.D.C.	0.12 rad. (7 °) before T.D.C.
Firing Order	1-3-4-2	
Injection Pressure	13.73 MPa (140 kgf/cm <sup>2</sup> , 1991 psi)	
Compression Ratio	22.6	21.8
Lubricating System	Forced lubrication by trochoid pump	
Oil Pressure Indicating	Electrical Type Switch	
Lubricating Filter	Full Flow Paper Filter (Cartridge Type)	
Cooling System	Pressurized radiator, forced circulation with water pump	
Starting System	Electric Starting with Starter	
Starting Motor	12 V, 2.5 kW	
Starting Support Device	By Glow Plug in Combustion Chamber	
Battery	12 V, 112 AH equivalent	
Charging Alternator	12 V, 540 W	
Fuel	Diesel Fuel No. 2-D (ASTM D975)	
Lubricating Oil	Class CF lubricating oil as per API classification is recommended. If this class of lubricating oil is not available, preferably use Class CD or CE lubricating oil. For details on recommended lubricating oils, see page G-5, 11.	
Lubricating Oil Capacity	13.2 L (3.49 U.S.gals)	
Weight (Dry)	241 kg (531 lbs)	250 kg (551 lbs)

\* The specification described above is of the standard engine of each model.

\* Conversion Formula : HP = 0.746 kW, PS = 0.7355 kW

W1028103

# PERFORMANCE CURVES

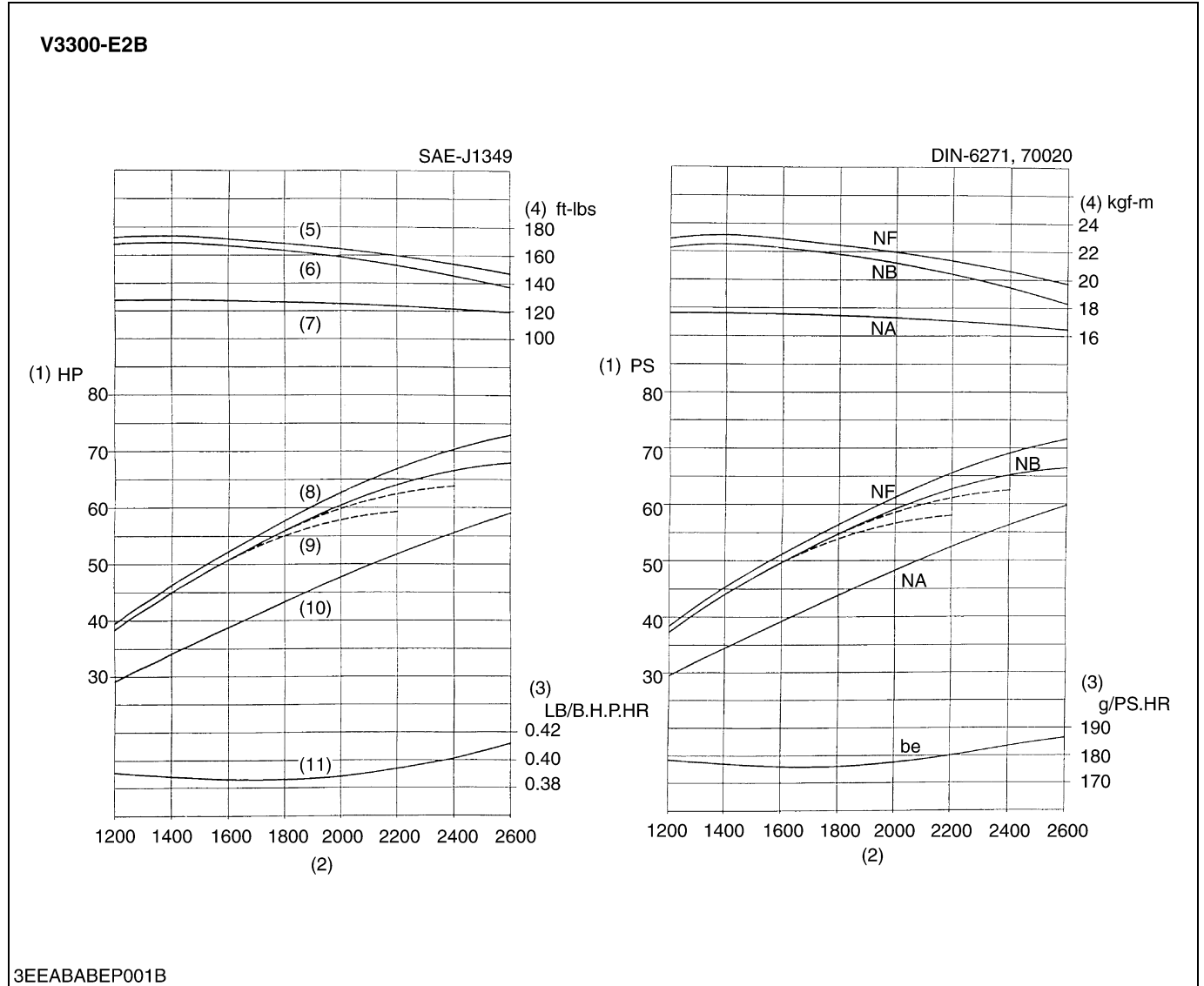

- |                      |                               |                               |                                  |
|----------------------|-------------------------------|-------------------------------|----------------------------------|
| (1) Brake Horsepower | (4) Torque                    | (7) Net Continuous Torque     | (10) Net Continuous B.H.P.       |
| (2) Engine Speed     | (5) Gross Intermittent Torque | (8) Gross Intermittent B.H.P. | (11) B.S.F.C. (Net Intermittent) |
| (3) B.S.F.C.         | (6) Net Intermittent Torque   | (9) Net Intermittent B.H.P.   |                                  |

**V3300-T-E2B**

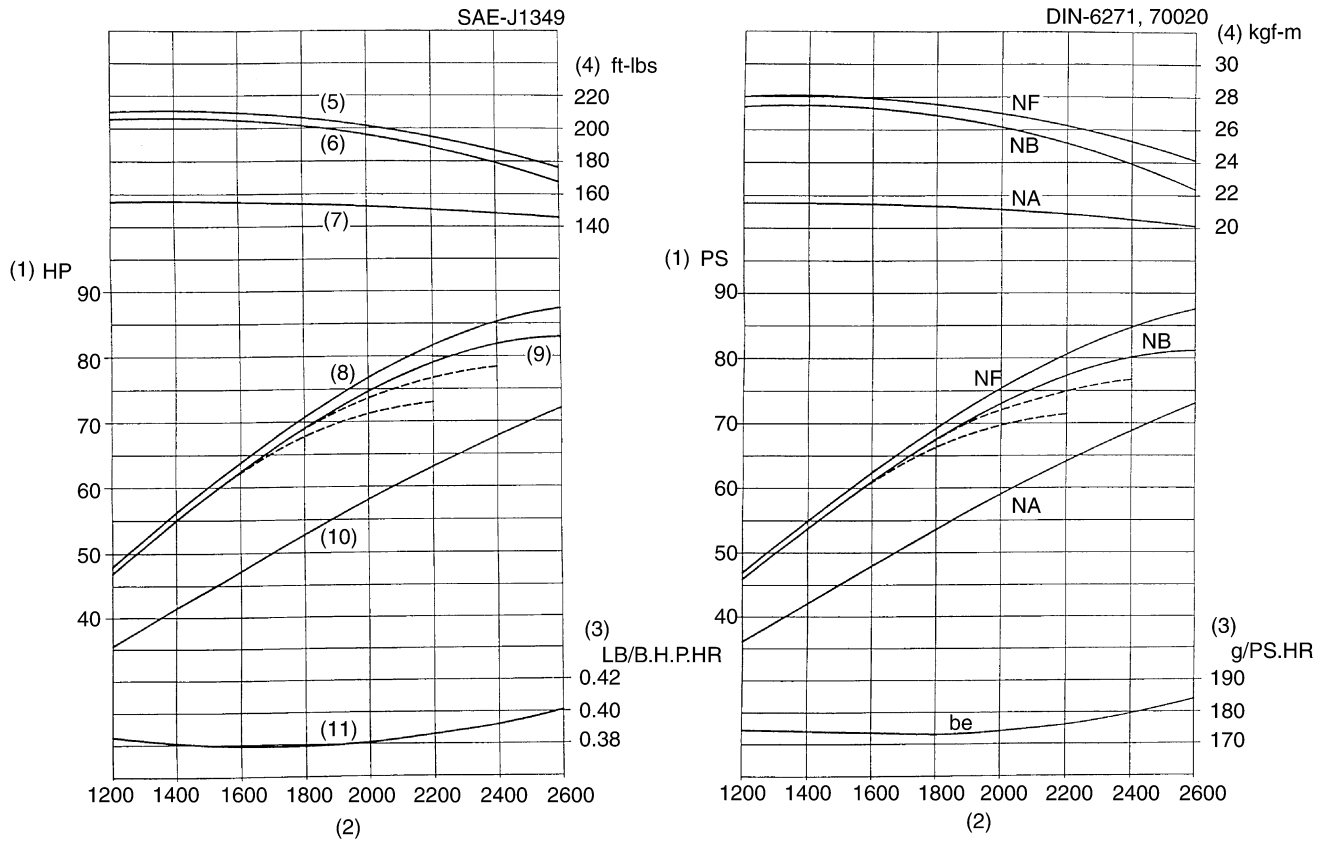

3EEABABEP002B

- |                      |                               |                               |                                  |
|----------------------|-------------------------------|-------------------------------|----------------------------------|
| (1) Brake Horsepower | (4) Torque                    | (7) Net Continuous Torque     | (10) Net Continuous B.H.P.       |
| (2) Engine Speed     | (5) Gross Intermittent Torque | (8) Gross Intermittent B.H.P. | (11) B.S.F.C. (Net Intermittent) |
| (3) B.S.F.C.         | (6) Net Intermittent Torque   | (9) Net Intermittent B.H.P.   |                                  |



# DIMENSIONS

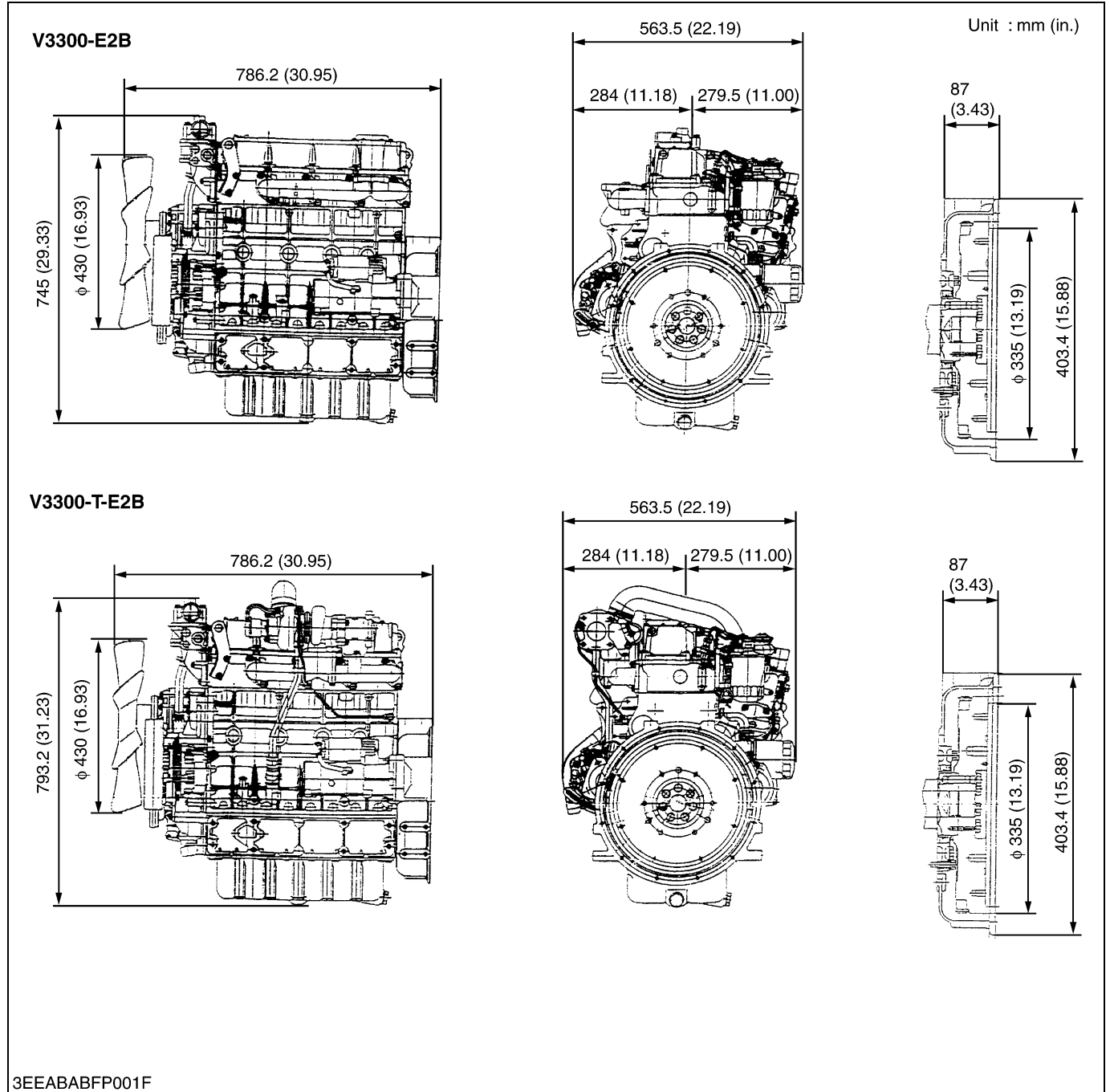

# GENERAL

## CONTENTS

1. ENGINE IDENTIFICATION.....	G-1
[1] MODEL NAME AND ENGINE SERIAL NUMBER .....	G-1
[2] E2B ENGINE.....	G-1
[3] CYLINDER NUMBER .....	G-2
2. GENERAL PRECAUTIONS.....	G-3
3. MAINTENANCE CHECK LIST.....	G-4
4. CHECK AND MAINTENANCE.....	G-6
[1] DAILY CHECK POINTS.....	G-6
[2] CHECK POINTS OF INITIAL 50 HOURS.....	G-8
[3] CHECK POINT OF EVERY 50 HOURS .....	G-9
[4] CHECK POINTS OF EVERY 250 HOURS.....	G-10
[5] CHECK POINTS OF EVERY 500 HOURS.....	G-12
[6] CHECK POINT OF EVERY 1000 HOURS .....	G-15
[7] CHECK POINTS OF EVERY 1 OR 2 MONTHS.....	G-16
[8] CHECK POINTS OF EVERY 1500 HOURS.....	G-18
[9] CHECK POINTS OF EVERY 3000 HOURS.....	G-20
[10]CHECK POINTS OF EVERY 1 YEAR.....	G-23
[11]CHECK POINTS OF EVERY 2 YEARS.....	G-24
5. SPECIAL TOOLS.....	G-27

# 1. ENGINE IDENTIFICATION

## [1] MODEL NAME AND ENGINE SERIAL NUMBER

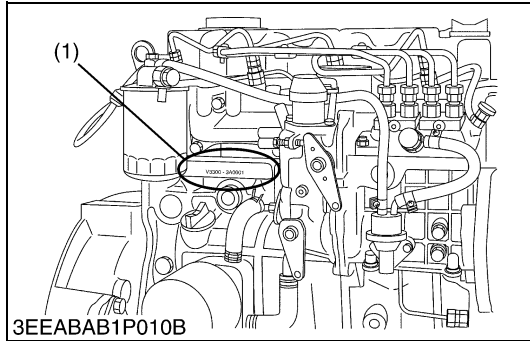

When contacting the manufacture, always specify your engine model name and serial number.

The engine model and its serial number need to be identified before the engine can be serviced or parts replaced.

### ■ Engine Serial Number

The engine serial number is an identified number for the engine. It is marked after the engine model number.

It indicates month and year of manufacture as follows.

#### • Year of manufacture

Alphabet or Number	Year	Alphabet or Number	Year
1	2001	F	2015
2	2002	G	2016
3	2003	H	2017
4	2004	J	2018
5	2005	K	2019
6	2006	L	2020
7	2007	M	2021
8	2008	N	2022
9	2009	P	2023
A	2010	R	2024
B	2011	S	2025
C	2012	T	2026
D	2013	V	2027
E	2014		

(1) Engine Model Name and Serial Number

W1010477

- **Month of manufacture**

Month	Engine Serial Number	
	0001 ~ 9999	10000 ~
January	A0001 ~ A9999	B0001 ~
February	C0001 ~ C9999	D0001 ~
March	E0001 ~ E9999	F0001 ~
April	G0001 ~ G9999	H0001 ~
May	J0001 ~ J9999	K0001 ~
June	L0001 ~ L9999	M0001 ~
July	N0001 ~ N9999	P0001 ~
August	Q0001 ~ Q9999	R0001 ~
September	S0001 ~ S9999	T0001 ~
October	U0001 ~ U9999	V0001 ~
November	W0001 ~ W9999	X0001 ~
December	Y0001 ~ Y9999	Z0001 ~

e.g. V3300-3A0001

“3” indicates 2003 and “A” indicates January.

So, 3A indicates that the engine was manufactured in January, 2003.

W1011076

## [2] E2B ENGINE

[ex. Model Name V3300-**E2B**-XXXX]

The emission controls that have been put into effect in various countries to prevent air pollution will be stepped up. The time to enforce the regulations differs depending on the engine output classifications.

Kubota has been supplying the diesel engines conforming to the emission regulations in respective countries. Exhaust emissions regulations shift to the second stage. Kubota executed the improvement of the engine according to this regulation.

In order to discriminate the engines conforming to Tier 1 / Phase 1 requirements and those conforming to Tier 2 / Phase 2 requirements, we have adopted E2B as a new model name for the engines conforming Tier 2 / Phase 2 regulations.

In the after-sale services for V3300-E2B and V3300-T-E2B series engines, only use the dedicated parts for E2B models and carry out the maintenance services accordingly.

## [3] CYLINDER NUMBER

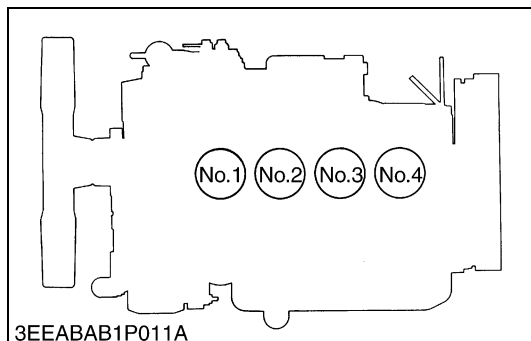

The cylinder numbers of Kubota diesel engine are designated as shown in the figure.

The sequence of cylinder numbers is given as No.1, No.2, No.3 and No.4 starting from the gear case side.

W1011077

## 2. GENERAL PRECAUTIONS

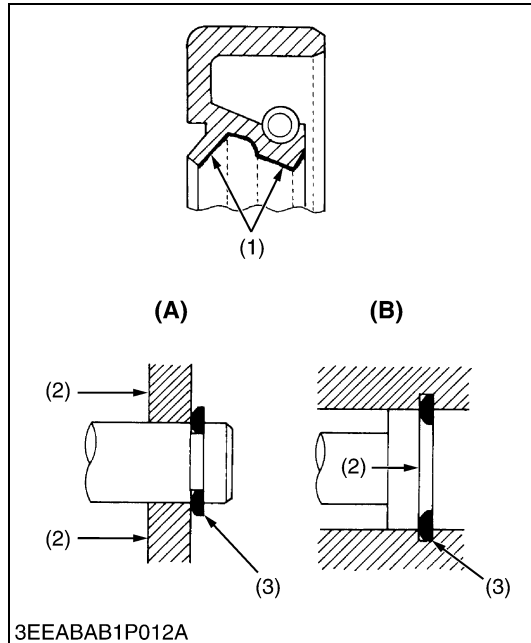

- During disassembly, carefully arrange removed parts in a clean area to prevent confusion later. Screws, bolts and nuts should be replaced in their original position to prevent reassembly errors.
- When special tools are required, use KUBOTA genuine special tools. Special tools which are not frequently used should be made according to the drawings provided.
- Before disassembling or servicing live wires, make sure to always disconnect the grounding cable from the battery first.
- Remove oil and dirt from parts before measuring.
- Use only KUBOTA genuine parts for parts replacement to maintain engine performance and to ensure safety.
- Gaskets and O-rings must be replaced during reassembly. Apply grease to new O-rings or oil seals before assembling.
- When reassembling external or internal snap rings, position them so that the sharp edge faces against the direction from which force is applied.
- Be sure to perform run-in the serviced or reassembled engine. Do not attempt to give heavy load at once, or serious damage may result to the engine.

- (1) Grease  
 (2) Force  
 (3) Place the Sharp Edge against the Direction of Force

**(A) External Snap Ring**  
**(B) Internal Snap Ring**

W1011734

### 3. MAINTENANCE CHECK LIST

To maintain long-lasting and safe engine performance, make it a rule to carry out regular inspections by following the table below.

Item	Service Interval									
	Initial 50 hrs	Every 50 hrs	Every 250 hrs	Every 500 hrs	Every 1000 hrs	Every 1 or 2 months	Every 1500 hrs	Every 3000 hrs	Every 1 year	Every 2 years
Changing engine oil	☆		☆						☆	
Replacing oil filter cartridge	☆			☆						
*Checking fuel hoses and clamps		☆								
*Cleaning air filter element (Replace the element after 6 times cleanings)			☆							
*Cleaning fuel filter			☆							
Checking battery electrolyte level			☆							
Checking radiator hoses and clamps			☆							
*Checking intake air line			☆							
Checking fan belt tension and damage	☆		☆							
*Replacing fuel filter cartridge				☆						
Replacing fan belt				☆						☆
Cleaning radiator interior				☆						
Checking valve clearance					☆					
Recharging battery						☆				
*Checking injection nozzle condition							☆			
*Checking turbocharger								☆		
Checking fuel injection pump								☆		
*Checking injection timing (spill timing)								☆		
*Replacing air filter element									☆	
Changing radiator coolant (L.L.C.)										☆
Replacing radiator hoses and clamps										☆
*Replacing fuel hoses and clamps										☆
*Replacing intake air line										☆
Replacing battery										☆

\* The items listed above (\* marked) are registered as emission related critical parts by KUBOTA in the U.S.EPA nonroad emission regulation.

As the engine owner, you are responsible for the performance of the required maintenance on the engine according to the above instruction.

W1029462

**CAUTION**

- When changing or inspecting, be sure to level and stop the engine.

**NOTE****Lubricating Oil**

With the emission control now in effect, the CF-4 and CG-4 lubricating oils have been developed for use of a low-sulfur fuel on-road vehicle engines. When an off-road vehicle engine runs on a high-sulfur fuel, it is advisable to employ the CF, CD or CE lubricating oil with a high total base number. If the CF-4 or CG-4 lubricating oil is used with a high-sulfur fuel, change the lubricating oil at shorter intervals.

- Lubricating oil recommended when a low-sulfur or high-sulfur fuel is employed.

Lubricating oil class	Fuel	Low sulfur (0.5 % $\geq$ )	High sulfur	Remarks
	CF		○	○
CF-4		○	X	
CG-4		○	X	

○ : Recommendable X : Not recommendable

W1035555

## 4. CHECK AND MAINTENANCE

### [1] DAILY CHECK POINTS

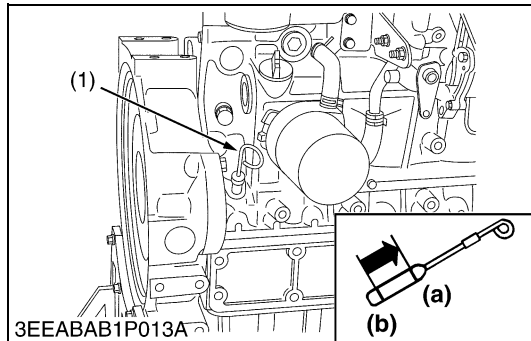

#### Checking Engine Oil Level

1. Level the engine.
2. To check the oil level, draw out the dipstick (1), wipe it clean, reinsert it, and draw it out again.  
Check to see that the oil level lies between the two notches.
3. If the level is too low, add new oil to the specified level.

#### ■ IMPORTANT

- When using an oil of different maker or viscosity from the previous one, drain old oil. Never mix two different types of oil.

#### ■ NOTE

- Be sure to inspect the engine, locating it on a horizontal place. If placed on gradients, accurately, oil quantity may not be measured.
- Be sure to keep the oil level between upper and lower limits of the dipstick. Too much oil may cause a drop in output or excessive blow-by gas. On the closed breather type engine in which mist is sucked through port, too much oil may caused oil hammer. While too little oil, may seize the engine's rotating and sliding parts.

(1) Dipstick

(a) Maximum

(b) Minimum

W1035676



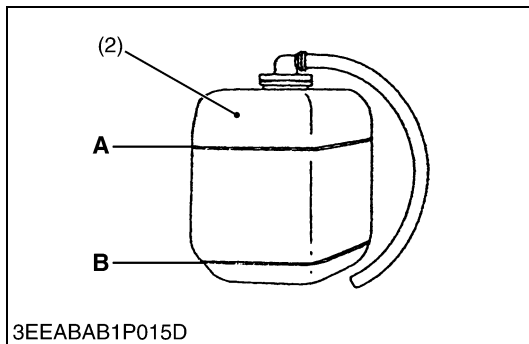
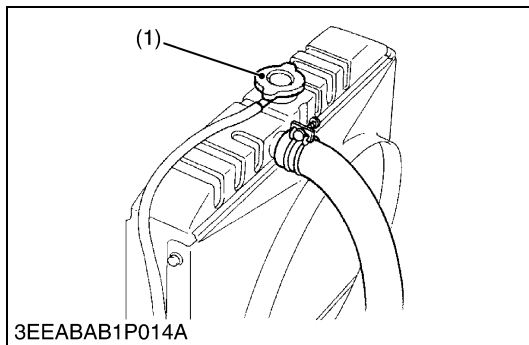

### **Checking and Replenish Coolant**

#### 1. Without recovery tank :

Remove the radiator cap (1) and check to see that the coolant level is just below the port.

#### With recovery tank (2) :

Check to see that the coolant level lies between **FULL (A)** and **LOW (B)**.

#### 2. If coolant level is too low, check the reason for decreasing coolant.

##### (Case 1)

If coolant is decreasing by evaporation, replenish only fresh, soft water.

##### (Case 2)

If coolant is decreasing by leak, replenish coolant of the same manufacture and type in the specified mixture ratio (fresh, soft water and L.L.C.). If the coolant brand cannot be identified, drain out all of the remaining coolant and refill with a totally new brand of coolant mix.



### **CAUTION**

- Do not remove the radiator cap until coolant temperature is below its boiling point. Then loosen the cap slightly to relieve any excess pressure before removing the cap completely.

### **IMPORTANT**

- During filling the coolant, air must be vented from the engine coolant passages. The air vents by jiggling the radiator upper and lower hoses.
- Be sure to close the radiator cap securely. If the cap is loose or improperly closed, coolant may leak out and the engine could overheat.
- Do not use an antifreeze and scale inhibitor at the same time.
- Never mix the different type or brand of L.L.C..

- (1) Radiator Cap  
(2) Recovery Tank

A: FULL  
B: LOW

W1035779

## [2] CHECK POINTS OF INITIAL 50 HOURS

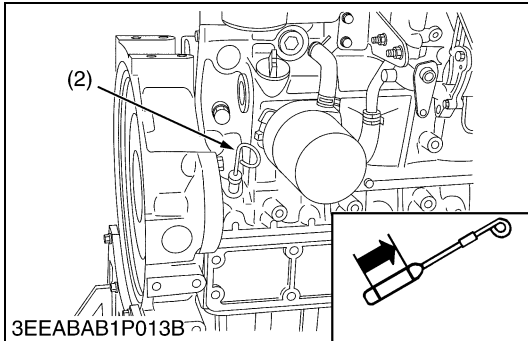
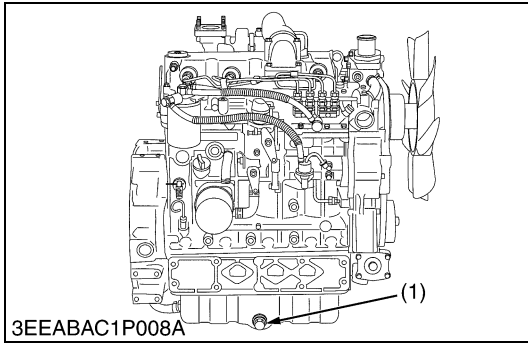

### Changing Engine Oil

#### ⚠ CAUTION

- **Be sure to stop engine before changing engine oil.**
- 1. Start and warm up the engine for approx. 5 minutes.
- 2. Place an oil pan underneath the engine.
- 3. To drain the used oil, remove the drain plug (1) at the bottom of the engine and drain the oil completely.
- 4. Screw the drain plug (1).
- 5. Fill new oil up to upper line on the dipstick (2).

#### ■ IMPORTANT

- **When using an oil of different maker or viscosity from the previous one, remove all of the old oil.**
- **Never mix two different types of oil.**
- **Engine oil should have properties of API classification CD/CE/CF/CF-4/CG-4.**
- **Use the proper SAE Engine Oil according to ambient temperature.**

Above 25 °C (77 °F)	SAE 30 or SAE 10W-30 SAE 10W-40
0 °C to 25 °C (32 °F to 77 °F)	SAE 20 or SAE 10W-30 SAE 10W-40
Below 0 °C (32 °F)	SAE 10W or SAE 10W-30 SAE 10W-40

Engine oil capacity	13.2 L 3.49 U.S.gals
---------------------	-------------------------

(1) Drain Plug

(2) Dipstick

W1016604

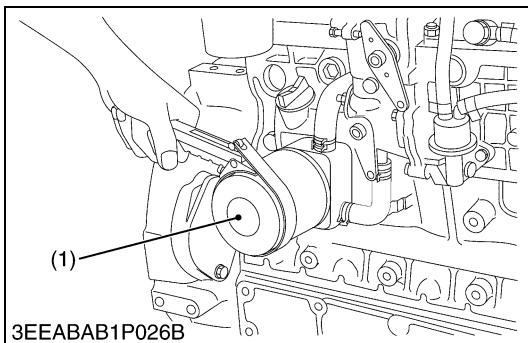

### Replacing Oil Filter Cartridge

#### ⚠ CAUTION

- **Be sure to stop the engine before changing filter cartridge.**
- 1. Remove the oil filter cartridge (1) with the filter wrench.
- 2. Apply a slight coat of oil onto the new cartridge gasket.
- 3. To install the new cartridge, screw it in by hand. Over tightening may cause deformation of rubber gasket.
- 4. After the new cartridge has been replaced, the engine oil normally decrease a little. Thus see that the engine oil does not leak through the seal and be sure to read the oil level on the dipstick. Then, replenish the engine oil up to the specified level.

#### ■ IMPORTANT

- **To prevent serious damage to the engine, replacement element must be highly efficient. Use only a KUBOTA genuine filter or its equivalent.**

(1) Engine Oil Filter Cartridge

W1017137

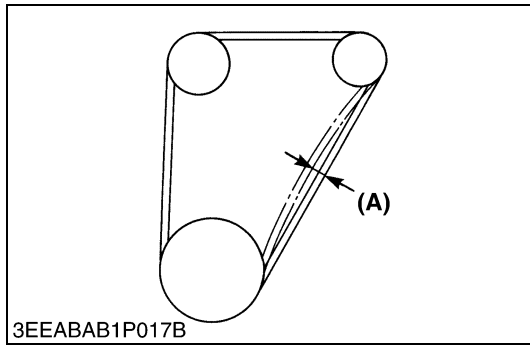

### Fan Belt Tension

1. Measure the deflection **(A)**, depressing the belt halfway between the fan drive pulley and alternator pulley at specified force 98 N (10 kgf, 22 lbs).
2. If the measurement is not within the factory specifications, loosen the alternator mounting screws and relocate the alternator to adjust.

Deflection <b>(A)</b>	Factory spec.	10 to 12 mm 0.394 to 0.472 in.
-----------------------	---------------	-----------------------------------

**(A) Deflection**

W1208957

## [3] CHECK POINT OF EVERY 50 HOURS

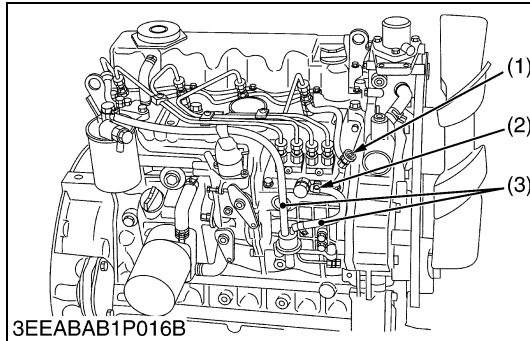

### Checking Fuel Hose and Clamp Bands

1. If the clamp (2) is loose, apply oil to the threads and securely retighten it.
2. The fuel hose (3) is made of rubber and ages regardless of the period service.  
Change the fuel pipe together with the clamp every two years.
3. However, if the fuel hose and clamps are found to be damaged or deteriorate earlier than two years, then change or remedy.
4. After the fuel hose and the clamps have been changed, bleed the fuel system.



### CAUTION

- **Stop the engine when attempting the check and change prescribed above.**

#### (When bleeding fuel system)

1. Fill the tank with fuel and open the cock.
2. Loosen the air vent coupling bolt of fuel filter a few turns.
3. When there is no more air bubbles in the fuel coming out of this coupling bolt, tighten the coupling bolt.
4. Open the air vent cock (1) on the top of fuel injection pump.
5. If equipped electrical fuel feed pump, turn the key on **AC** position and pump the fuel up for 10 to 15 seconds.  
If equipped mechanical fuel feed pump, set the stop lever on stop position and crank the engine for 10 to 15 seconds.
6. Close securely the air vent cock (1) after air bleeding.

#### ■ IMPORTANT

- **Except when venting the air, be sure to keep closed the air vent coupling bolt of the fuel injection pump. Otherwise, the engine may stall.**

(1) Air Vent Cock  
(2) Clamp

(3) Fuel Hose

W1035921

## [4] CHECK POINTS OF EVERY 250 HOURS

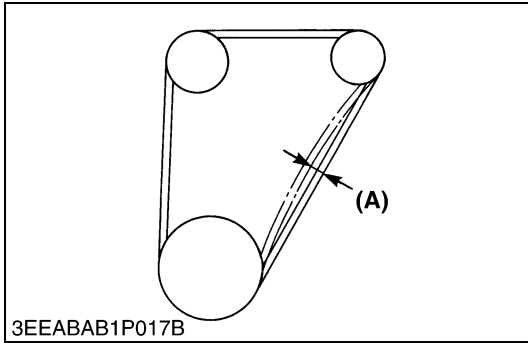

### Fan Belt Tension

1. Measure the deflection **(A)**, depressing the belt halfway between the fan drive pulley and alternator pulley at specified force 98 N (10 kgf, 22 lbs).
2. If the measurement is not within the factory specifications, loosen the alternator mounting screws and relocate the alternator to adjust.

Deflection <b>(A)</b>	Factory spec.	10 to 12 mm 0.394 to 0.472 in.
-----------------------	---------------	-----------------------------------

**(A) Deflection**

W1014131

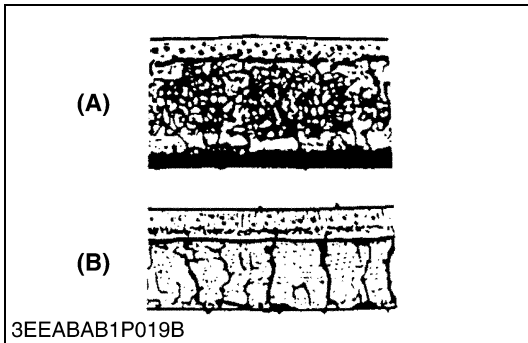

### Fan Belt Damage and Wear

1. Check the fan belt for damage.
2. If the fan belt is damaged, replace it.
3. Check if the fan belt is worn and sunk in the pulley groove.
4. If the fan belt is nearly worn out and deeply sunk in the pulley groove, replace it.

**(A) Good**

**(B) Bad**

W1209480

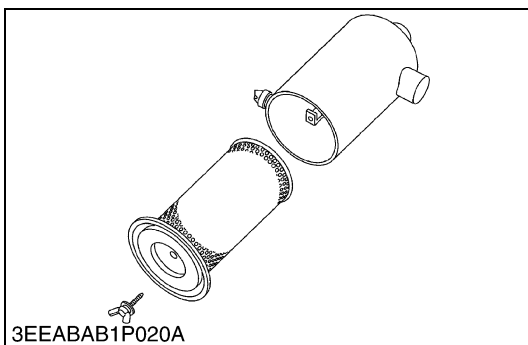
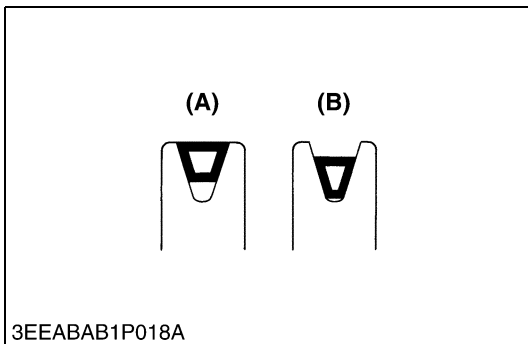

### Cleaning Air Cleaner Element

1. Remove the air cleaner element.
2. Use clean dry compressed air on the inside of the element.  
Pressure of compressed air must be under 205 kPa (2.1 kgf/cm<sup>2</sup>, 30 psi).  
Maintain reasonable distance between the nozzle and the filter.

#### ■ NOTE

- The air cleaner uses a dry element. Never apply oil to it.
- Do not run the engine with filter element removed.
- Change the element once a year or every 6th cleaning.

W1045746

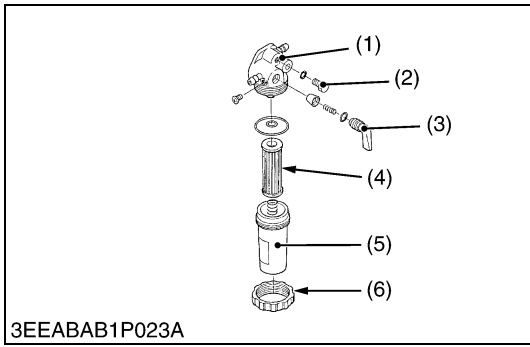

**Cleaning Fuel Filter (Element Type only)**

1. Close the fuel cock (3).
2. Unscrew the retaining ring (6) and remove the filter cup (5), and rinse the inside with kerosene.
3. Take out the element (4) and dip it in the kerosene to rinse.
4. After cleaning, reassemble the fuel filter, keeping out dust and dirt.
5. Bleed the fuel system.

■ **IMPORTANT**

- If dust and dirt enter the fuel, the fuel injection pump and injection nozzle will wear quickly. To prevent this, be sure to clean the filter cup (5) periodically.

- |                   |                    |
|-------------------|--------------------|
| (1) Cock Body     | (4) Filter Element |
| (2) Air Vent Plug | (5) Filter Cup     |
| (3) Fuel Cock     | (6) Retaining Ring |

W1046058

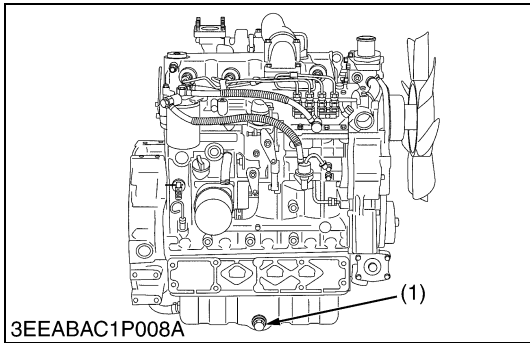

**Changing Engine Oil**

**CAUTION**

- Be sure to stop engine before changing engine oil.
1. Start and warm up the engine for approx. 5 minutes.
  2. Place an oil pan underneath the engine.
  3. To drain the used oil, remove the drain plug (1) at the bottom of the engine and drain the oil completely.
  4. Screw the drain plug (1).
  5. Fill new oil up to upper line on the dipstick (2).

■ **IMPORTANT**

- When using an oil of different maker or viscosity from the previous one, remove all of the old oil.
- Never mix two different types of oil.
- Engine oil should have properties of API classification CD/CE/CF/CF-4/CG-4.
- Use the proper SAE Engine Oil according to ambient temperature.

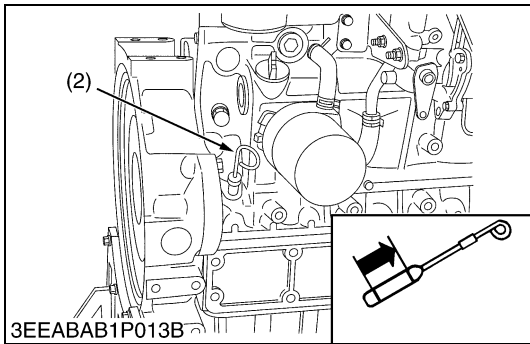

Above 25 °C (77 °F)	SAE 30 or SAE 10W-30 SAE 10W-40
0 °C to 25 °C (32 °F to 77 °F)	SAE 20 or SAE 10W-30 SAE 10W-40
Below 0 °C (32 °F)	SAE 10W or SAE 10W-30 SAE 10W-40

Engine oil capacity	13.2 L 3.49 U.S.gals
---------------------	-------------------------

- |                |              |
|----------------|--------------|
| (1) Drain Plug | (2) Dipstick |
|----------------|--------------|

W1014590

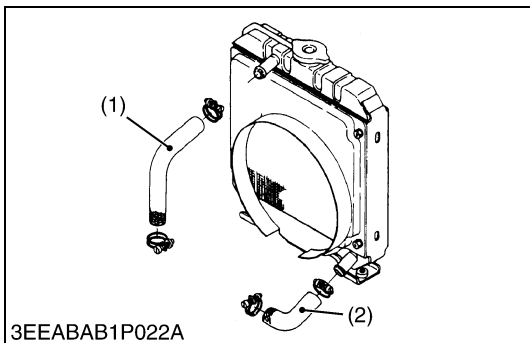

**Checking Radiator Hoses and Clamp Bands**

1. Check to see if the radiator hoses are properly fixed every 250 hours of operation or every six months, whichever comes first.
2. If the clamp is loose, apply oil to the threads and retighten it securely.
3. The water hose is made of rubber and tends to age. It must be replaced every two years. Also replace the clamp and tighten it securely.

- |                |                |
|----------------|----------------|
| (1) Upper Hose | (2) Lower Hose |
|----------------|----------------|

W1029518

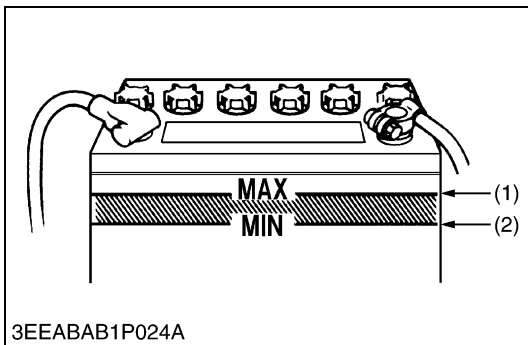

### Checking Battery Electrolyte Level

1. Check the battery electrolyte level.
2. If the level is below than lower level line (2), and the distilled water to pour level of each cell.

(1) Upper Level Line (2) Lower Level Line

W1047154

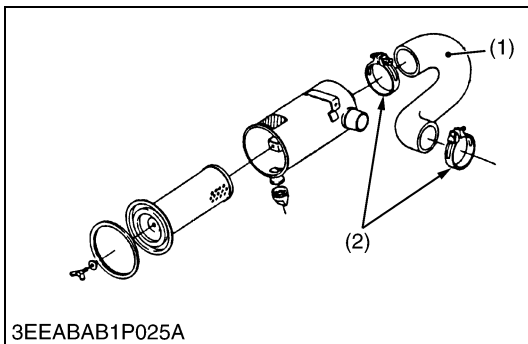

### Checking Intake Air Line

1. Check to see if the intake air hose(s) are properly fixed every 250 hours of operation.
2. If the clamp is loose, apply oil to the threads and retighten it securely.
3. The intake air hose(s) is made of rubber and tends to age. It must be change every two years. Also change the clamp and tighten it securely.

#### ■ IMPORTANT

- To prevent serious damage to the engine, keep out any dust inside the intake air line.

(1) Intake Air Hose (2) Clamp

W1029631

## [5] CHECK POINTS OF EVERY 500 HOURS

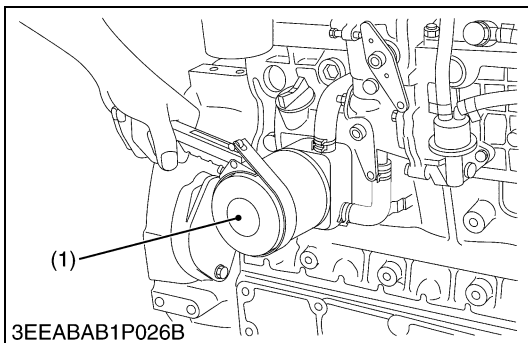

### Replacing Oil Filter Cartridge

#### ⚠ CAUTION

- Be sure to stop the engine before changing filter cartridge.

1. Remove the oil filter cartridge (1) with the filter wrench.
2. Apply a slight coat of oil onto the new cartridge gasket.
3. To install the new cartridge, screw it in by hand. Over tightening may cause deformation of rubber gasket.
4. After the new cartridge has been replaced, the engine oil normally decrease a little. Thus see that the engine oil does not leak through the seal and be sure to read the oil level on the dipstick. Then, replenish the engine oil up to the specified level.

#### ■ IMPORTANT

- To prevent serious damage to the engine, replacement element must be highly efficient. Use only a KUBOTA genuine filter or its equivalent.

(1) Engine Oil Filter Cartridge

W1015117

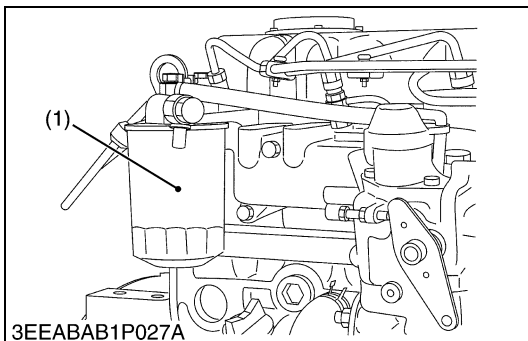

### Replacing Fuel Filter Cartridge (Cartridge Type)

Water and dust in fuel are collected in the filter cartridge. So, change the filter cartridge every 500 hours service.

1. Remove the used filter cartridge with filter wrench.
2. Apply a thin film of fuel to the surface of new filter cartridge gasket before screwing on.
3. Then tighten enough by hand.
4. Loosen the air vent plug to let the air out.
5. Start engine and check for fuel leakage.

(1) Fuel Filter Cartridge

W1037062

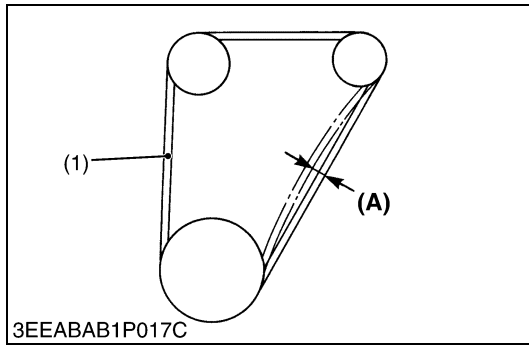

### Replacing Fan Belt

1. Remove the alternator.
2. Remove the fan belt (1).
3. Replace new fan belt.
4. Install the alternator.
5. Check the fan belt tension.

Deflection (A)	Factory spec.	10.0 to 12.0 mm / 98 N 0.394 to 0.472 in. / 98 N (10 kgf, 22 lbs)
----------------	---------------	---

(1) Fan Belt

(A) Deflection

W1052220

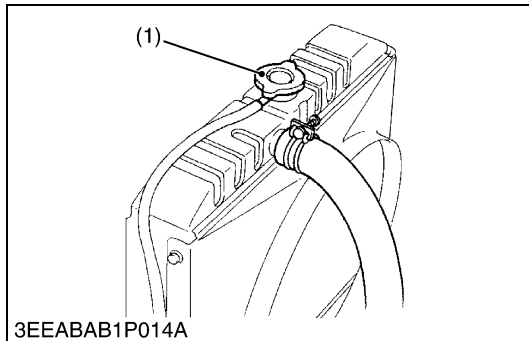

### Cleaning Water Jacket and Radiator Interior

#### ⚠ CAUTION

- Do not remove the radiator cap when the engine is hot. Then loosen cap slightly to the stop to relieve any excess pressure before removing cap completely.

1. Stop the engine and let cool down.
2. To drain the coolant, open the radiator drain plug (2) and remove the radiator cap (1). Then radiator cap (1) must be removed to completely drain the coolant. And open the drain cock of engine body.
3. After all coolant is drained, close the drain plug.
4. Fill with clean water and cooling system cleaner.
5. Follow directions of the cleaner instruction.
6. After flushing, fill with clean water and anti-freeze until the coolant level is just below the port. Install the radiator cap (1) securely.
7. Fill with coolant up to "FULL" (A) mark on the recovery tank (3).
8. Start and operate the engine for few minutes.
9. Stop the engine and let cool. Check coolant level of radiator and recovery tank (3) and add coolant if necessary.

#### ■ IMPORTANT

- Do not start engine without coolant.
- Use clean, fresh, soft water and anti-freeze to fill the radiator and recovery tank.
- When the anti-freeze is mixed with fresh, soft water, the anti-freeze mixing ratio must be less than 50 %.
- Securely tighten radiator cap. If the cap is loose or improperly fitted, water may leak out and the engine could overheat.

- (1) Radiator Cap  
(2) Drain Plug  
(3) Recovery Tank

A : Full  
B : Low

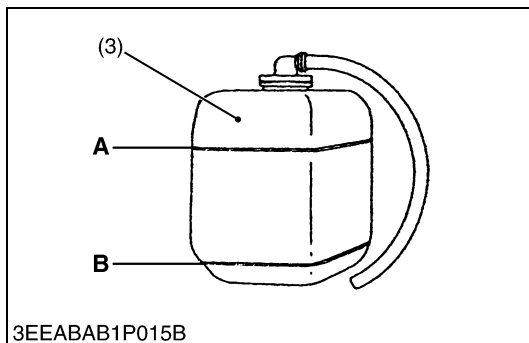
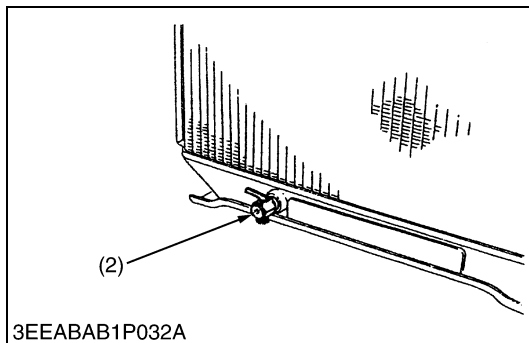

W1038102

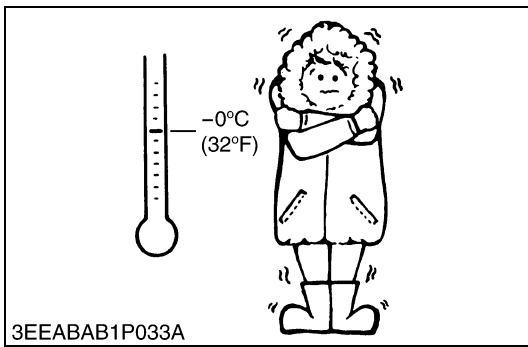

### Anti-Freeze

- There are two types of anti-freeze available: use the permanent type (PT) for this engine.
- Before adding anti-freeze for the first time, clean the radiator interior by pouring fresh, soft water and draining it a few times.
- The procedure for mixing water and anti-freeze differs according to the make of the anti-freeze and the ambient temperature. Basically, it should be referred to SAE J1034 standard, more specifically also to SAE J814c.
- Mix the anti-freeze with fresh, soft water, and then fill into the radiator.

### ■ IMPORTANT

- **When the anti-freeze is mixed with fresh, soft water, the anti-freeze mixing ratio must be less than 50 %.**

Vol % anti-freeze	Freezing point		Boiling point*	
	°C	°F	°C	°F
40	-24	-11.2	106	222.8
50	-37	-34.6	108	226.4

\* At  $1.013 \times 100000$  Pa (760 mmHg) pressure (atmospheric). A higher boiling point is obtained by using a radiator pressure cap which permits the development of pressure within the cooling system.

### ■ NOTE

- **The above data represents industrial standards that necessitate a minimum glycol content in the concentrated anti-freeze.**
- **When the coolant level drops due to evaporation, add fresh, soft water only to keep the anti-freeze mixing ratio less than 50 %. In case of leakage, add anti-freeze and fresh, soft water in the specified mixing ratio.**
- **Anti-freeze absorbs moisture. Keep unused anti-freeze in a tightly sealed container.**
- **Do not use radiator cleaning agents when anti-freeze has been added to the coolant.**  
(Anti-freeze contains an anti-corrosive agent, which will react with the radiator cleaning agent forming sludge which will affect the engine parts.)

W1039218



## [6] CHECK POINT OF EVERY 1000 HOURS

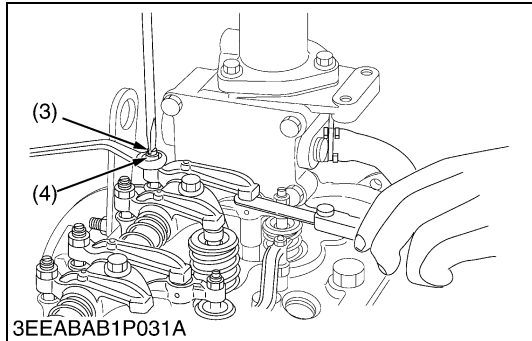
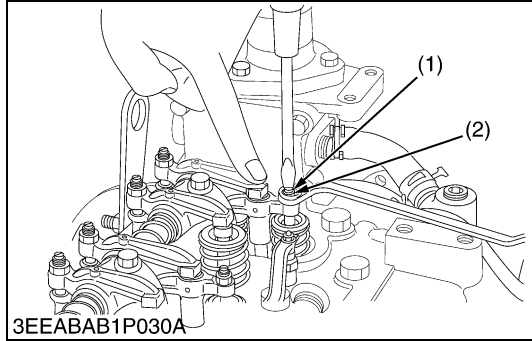
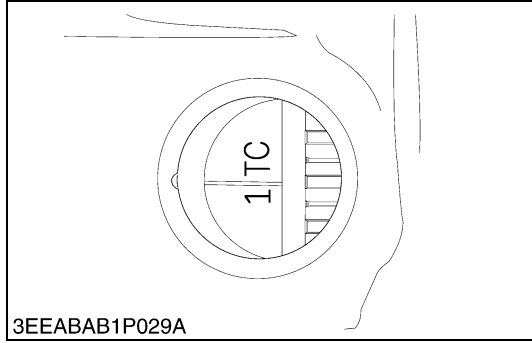

### Checking Valve Clearance

#### ■ IMPORTANT

- Valve clearance must be checked and adjusted when engine is cold.
1. Remove the head cover.
  2. Align the 1TC mark of flywheel and the convex of flywheel housing timing windows so that the first piston (gear case side) comes to the compression top dead center.
  3. Before adjusting the valve clearance of intake valve, adjust the bridge evenly to the valves stem.
  4. Loosen the lock nut (2) and adjust with screw (1).
  5. Slightly push the rocker arm (intake side) by your fingers and screw in the adjusting screw slowly until you feel the screw touch the top of valve stem, then tighten the lock nut.
  6. Loosen the lock nut (4) of adjusting screw (3) (push rod side) and insert the thickness gauge between the rocker arm and the bridge head. Set the adjusting screw to the specified value, then tighten the lock nut.
  7. Adjust the clearance between the rocker arm (exhaust side) and the exhaust valve to the specified value.

Valve clearance	Factory spec.	0.23 to 0.27 mm 0.0091 to 0.0106 in.
-----------------	---------------	---

#### ■ NOTE

- After adjusting, tighten the lock nut (4) securely.

Valve arrangement Adjustment cylinder Location of piston		IN.	EX
When No.1 piston is at compression top dead center	1st	☆	☆
	2nd	☆	
	3rd		☆
	4th		
When No.1 piston is at overlap position	1st		
	2nd		☆
	3rd	☆	
	4th	☆	☆

Tightening torque	Cylinder head cover screw	6.9 to 11.3 N·m 0.7 to 1.15 kgf·m 5.1 to 8.32 ft-lbs
-------------------	---------------------------	--

- (1) Adjusting Screw  
(2) Lock Nut

- (3) Adjusting Screw  
(4) Lock Nut

W1037215

## [7] CHECK POINTS OF EVERY 1 OR 2 MONTHS

### Recharging



#### CAUTION

- When the battery is being activated, hydrogen and oxygen gases in the battery are extremely explosive. Keep open sparks and flames away from the battery at all times, especially when charging the battery.
- When charging battery, remove battery vent plugs.
- When disconnecting the cable from the battery, start with the negative terminal first. When connecting the cable to the battery, start with the positive terminal first.
- Never check battery charge by placing a metal object across the posts.

Use a voltmeter or hydrometer.

#### 1) Slow Charging

1. Add distilled water if the electrolyte level is low. When charging, the amount of electrolyte should be slightly lower than the specified level to prevent overflow.
2. Connect the battery to the charging unit, following the manufacture's instructions.
3. As the electrolyte generates gas while charging, remove all port caps.
4. The electrolyte temperature must not exceed 40 °C (104 °F) during charging.  
If it exceed 40 °C (104 °F), decrease the charging amperage or stop charging for a while.
5. When charging several batteries in series, charge at the rate of the smallest battery in the line.

#### 2) Quick Charging

1. Determine the proper charging current and charging time with the tester attached to the quick charger.
2. Determine the proper charging current as 1/1 of the battery capacity. If the battery capacity exceeds 50 Ah, consider 50 A as the maximum.

#### ■ Precaution for Operating a Quick Charger

- Operate with a quick charger differs according to the type.  
Consult the instruction manual and use accordingly.

W1052658

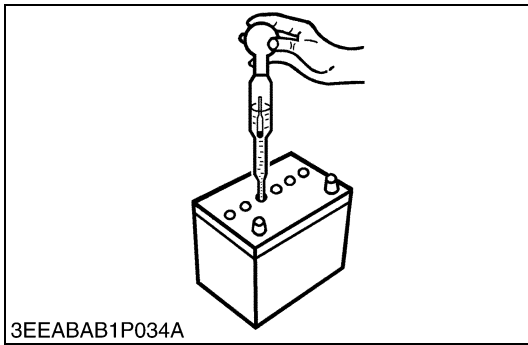

3EEABAB1P034A

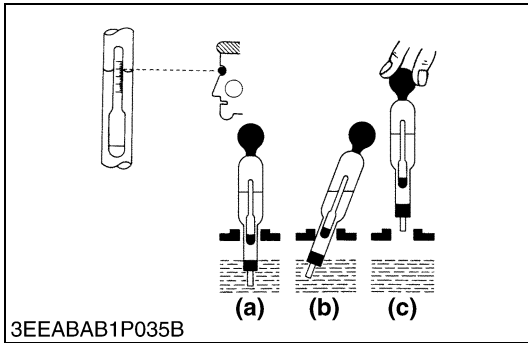

3EEABAB1P035B

### Battery Specific Gravity

1. Check the specific gravity of the electrolyte in each cell with a hydrometer.
2. When the electrolyte temperature differs from that at which the hydrometer was calibrated, correct the specific gravity reading following the formula mentioned in **(Reference)**.
3. If the specific gravity is less than 1.215 (after it is corrected for temperature), charge or replace the battery.
4. If the specific gravity differs between any two cells by more than 0.05, replace the battery.

#### NOTE

- **Hold the hydrometer tube vertical without removing it from the electrolyte.**
- **Do not suck too much electrolyte into the tube.**
- **Allow the float to move freely and hold the hydrometer at eye level.**
- **The hydrometer reading must be taken at the highest electrolyte level.**

#### (Reference)

- Specific gravity slightly varies with temperature. To be exact, the specific gravity decreases by 0.0007 with an increase of 1 °C (0.0004 with an increase of 1 °F) in temperature, and increases by 0.0007 with a decreases of 1 °C (0.0004 with a decrease of 1 °F).

Therefore, using 20 °C (68 °F) as a reference, the specific gravity reading must be corrected by the following formula :

- Specific gravity at 20 °C = Measured value + 0.0007 × (electrolyte temperature : 20 °C)
- Specific gravity at 68 °F = Measured value + 0.0004 × (electrolyte temperature : 68 °F)

Specific Gravity	State of Charge
1.260 Sp. Gr.	100 % Charged
1.230 Sp. Gr.	75 % Charged
1.200 Sp. Gr.	50 % Charged
1.170 Sp. Gr.	25 % Charged
1.140 Sp. Gr.	Very Little Useful Capacity
1.110 Sp. Gr.	Discharged

At an electrolyte temperature of 20 °C (68 °F)

(a) Good

(b) Bad

(c) Bad

W1012763

## [8] CHECK POINTS OF EVERY 1500 HOURS

### CAUTION

- Check the injection pressure and condition after confirming that there is nobody standing in the direction the fume goes.
- If the fume from the nozzle directly contacts the human body, cells may be destroyed and blood poisoning may be caused.

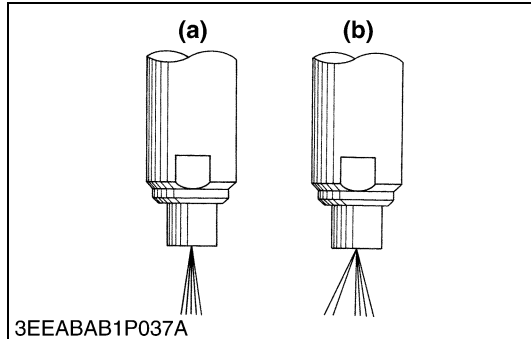

### Nozzle Spraying Condition

1. Set the injection nozzle to a nozzle tester, and check the nozzle spraying condition.
2. If the spraying condition is defective, replace the nozzle piece.

(a) Good

(b) Bad

W10411400

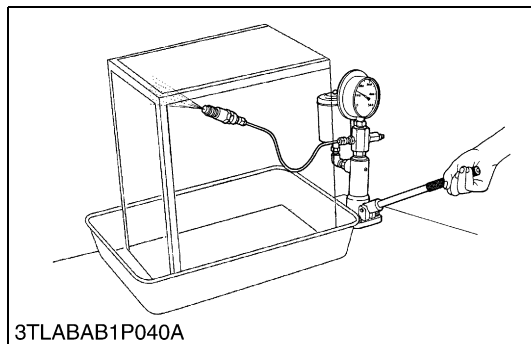

### Fuel Injection Pressure

1. Set the injection nozzle to a nozzle tester.
2. Slowly move the tester handle to measure the pressure at which fuel begins jetting out from the nozzle.
3. If the measurement is not within the factory specifications, replace the adjusting washer (1) in the nozzle holder to adjust it.

#### (Reference)

- Pressure variation with 0.025 mm (0.0010 in.) difference of adjusting washer thickness.  
Approx. 588 kPa (6.0 kgf/cm<sup>2</sup>, 85 psi)

Fuel injection pressure	Factory spec.	13.73 to 14.71 MPa 140 to 150 kgf/cm <sup>2</sup> 1991 to 2134 psi
-------------------------	---------------	--

(1) Adjusting Washer

W10182100

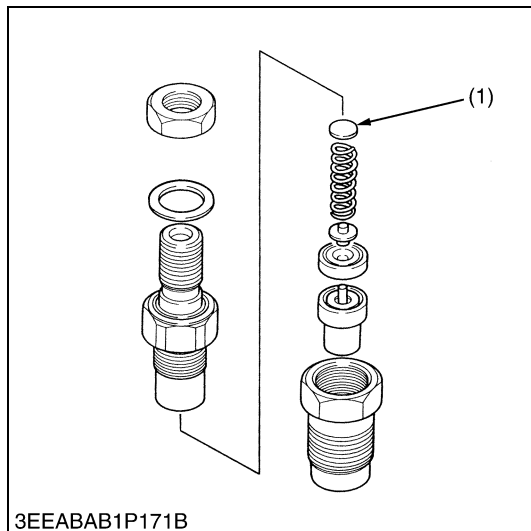

### Valve Seat Tightness

1. Set the injection nozzle to a nozzle tester.
2. Raise the fuel pressure, and keep at 12.75 MPa (130 kgf/cm<sup>2</sup>, 1849 psi) for 10 seconds.
3. If any fuel leak is found, replace the nozzle piece.

Valve seat tightness	Factory spec.	No fuel leak at 12.75 MPa 130 kgf/cm <sup>2</sup> 1849 psi
----------------------	---------------	---

W10412730

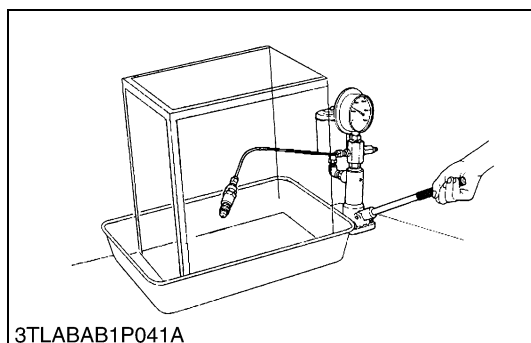

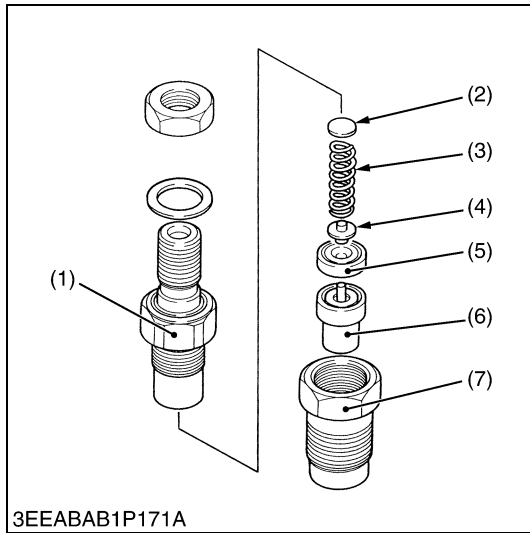

**Nozzle Holder**

1. Secure the nozzle retaining nut (7) with a vise.
2. Remove the nozzle holder (1), and take out parts inside.

**(When reassembling)**

- Assemble the nozzle in clean fuel oil.
- Install the push rod (4), noting its direction.
- After assembling the nozzle, be sure to adjust the fuel injection pressure.

Tightening torque	Nozzle holder	34.3 to 39.2 N·m 3.5 to 4.0 kgf·m 25.3 to 28.9 ft-lbs
	Overflow pipe retaining nut	19.6 to 24.5 N·m 2.0 to 2.5 kgf·m 14.5 to 18.1 ft-lbs
	Nozzle holder assembly	49.0 to 68.6 N·m 5.0 to 7.0 kgf·m 36.2 to 50.6 ft-lbs

- |                      |                          |
|----------------------|--------------------------|
| (1) Nozzle Holder    | (5) Distance Piece       |
| (2) Adjusting Washer | (6) Nozzle Piece         |
| (3) Nozzle Spring    | (7) Nozzle Retaining Nut |
| (4) Push Rod         |                          |

W1018491

## [9] CHECK POINTS OF EVERY 3000 HOURS

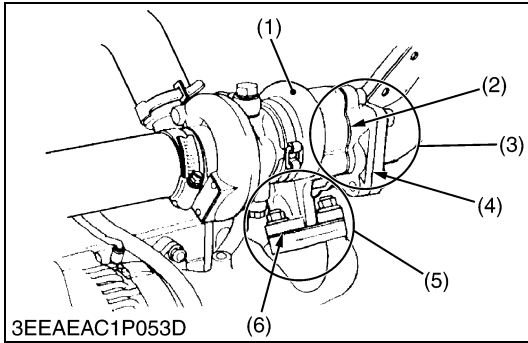

### Checking Turbocharger

#### **(Turbine Side)**

1. Check the exhaust port (3) and inlet port (5) side of turbine housing (1) to see if there is no exhaust gas leak.
2. If any gas leak is found, retighten the bolts and nuts or replace the gasket (2) / (4) / (6) with new one.

#### **(Compressor Side)**

1. Check the inlet hose (9) of the compressor cover (10) to see if there is no air leak.
2. If any air leak is found, change the clamp (8) and / or inlet hoses.
3. Check the intake hose (7) and the clamp to see if there is not loose or crack.
4. If any loose or crack is found, tighten the cramp or change the hose to prevent dust from entry.

#### **(Radial Clearance)**

1. If the wheel contact to the housing, replace the turbocharger assembly with new one.

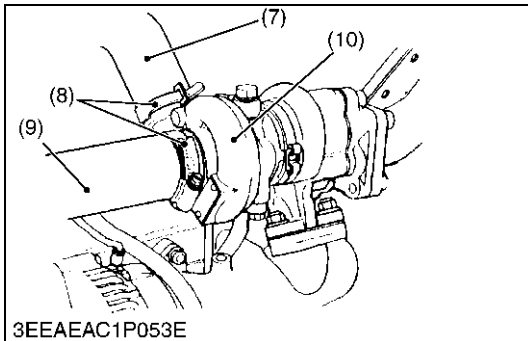

- |                     |                       |
|---------------------|-----------------------|
| (1) Turbine Housing | (6) Gasket            |
| (2) Gasket          | (7) Intake Hose       |
| (3) Exhaust Port    | (8) Clamp             |
| (4) Gasket          | (9) Inlet Hose        |
| (5) Inlet Port      | (10) Compressor Cover |

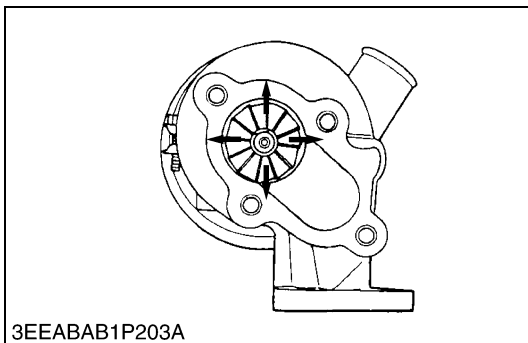

W1022082

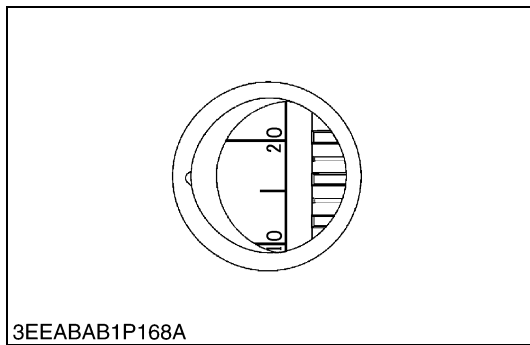
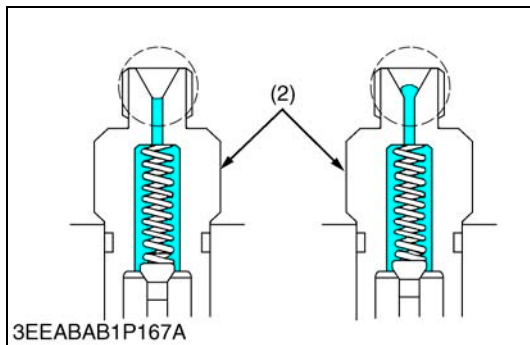
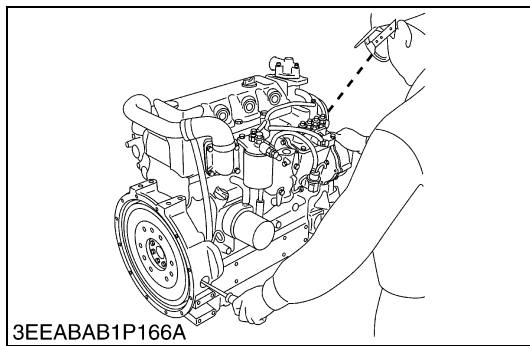
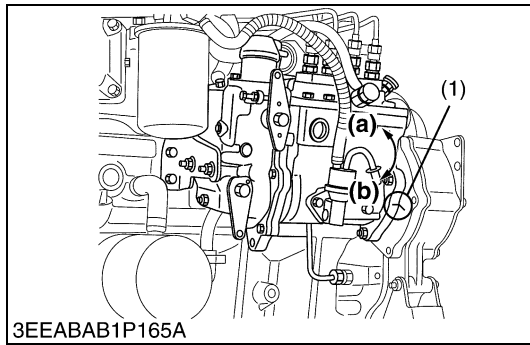

**Injection Timing**

1. Make sure of matching the injection timing align mark (1) of the injection pump unit and the plate (gearcase), as shown in the illustration.
2. Remove the injection pipes.
3. Remove the stop solenoid.
4. Turn the flywheel counterclockwise (viewed from flywheel side) until the fuel fills up to the hole of the delivery valve holder (2) for No.1 cylinder.
5. After the fuel fills up to the hole of the delivery valve holder for No.1 cylinder, turn back (clockwise) the flywheel around 1.57 rad (90 °).
6. Turn the flywheel counterclockwise to set at around 0.35 rad (20 °) before T.D.C..
7. Slowly turn the flywheel counterclockwise and stop turning when the fuel begins to come up, to get the present injection timing.
8. Check to see the degree on flywheel.  
The flywheel has mark “1TC”, “10” and “20” for the crank angle before the top dead center of No.1 piston.
9. If the injection timing is not within the specification, rotate the injection pump unit to adjust the injection timing.

■ **IMPORTANT**

- **When installing the injection pump unit to the engine body, follow the correct procedure. See the “Injection Pump Unit”.**

Injection timing	Factory spec.	V3300-E2B	0.19 to 0.23 rad (11 ° to 13 °) before T.D.C.
		V3300-T-E2B	0.11 to 0.14 rad (6 ° to 8 °) before T.D.C.

Tightening torque	Injection pipe retaining nut	22.6 to 36.3 N·m 2.3 to 3.7 kgf·m 16.6 to 26.8 ft-lbs
	Injection pump unit mounting nut	17.7 to 20.6 N·m 1.8 to 2.1 kgf·m 13.0 to 15.2 ft-lbs

- (1) Injection Timing Align Mark
- (2) Delivery Valve Holder

- (a) Injection Timing Advanced
- (b) Injection Timing Retarded

W1072910

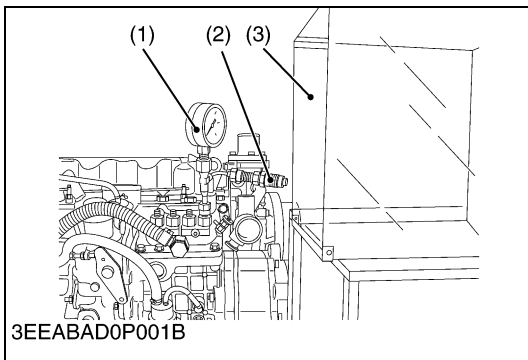

### Checking Injection Pump

#### (Fuel Tightness of Pump Element)

1. Remove the engine stop solenoid.
2. Remove the injection pipes and glow plugs.
3. Install the injection pump pressure tester to the injection pump.
4. Install the injection nozzle (2) jetted with the proper injection pressure to the injection pump pressure tester (1). (Refer to the figure.)
5. Set the speed control lever to the maximum speed position.
6. Run the starter to increase the pressure.
7. If the pressure can not reach the allowable limit, replace the pump with new one or repair with a Kubota-authorized pump service shop.

#### (Fuel Tightness of Delivery Valve)

1. Remove the engine stop solenoid.
2. Remove the injection pipes and glow plugs.
3. Set a pressure tester to the fuel injection pump.
4. Install the injection nozzle (2) jetted with the proper injection pressure to the injection pump pressure tester (1).
5. Run the starter to increase the pressure.
6. Stop the starter when the fuel jets from the injection nozzle. After that, turn the flywheel by the hand and raise the pressure to approx. 13.73 MPa (140 kgf/cm<sup>2</sup>, 1991 psi).
7. Now turn the flywheel back about half a turn (to keep the plunger free). Maintain the flywheel at this position and clock the time taken for the pressure to drop from 13.73 to 12.75 MPa (from 140 to 130 kgf/cm<sup>2</sup>, from 1991 to 1849 psi).
8. Measure the time needed to decrease the pressure from 13.73 to 12.75 MPa (140 to 130 kgf/cm<sup>2</sup>, 1991 to 1849 psi).
9. If the measurement is less than allowable limit, replace the pump with new one or repair with a Kubota-authorized pump service shop.

Fuel tightness of pump element	Allowable limit	13.73 MPa 140 kgf/cm <sup>2</sup> 1991 psi
Fuel tightness of delivery valve	Factory spec.	10 seconds 13.73 → 12.75 MPa 140 → 130 kgf/cm <sup>2</sup> 1991 → 1849 psi
	Allowable limit	5 seconds 13.73 → 12.75 MPa 140 → 130 kgf/cm <sup>2</sup> 1991 → 1849 psi

#### ■ NOTE

- **Never try to disassemble the injection pump assembly. For repairs, you are strongly requested to contact a Kubota-authorized pump service shop.**

- (1) Injection Pump Pressure Tester      (3) Protection Cover for Jetted Fuel  
(2) Injection Nozzle

W1022357



# [10] CHECK POINTS OF EVERY 1 YEAR

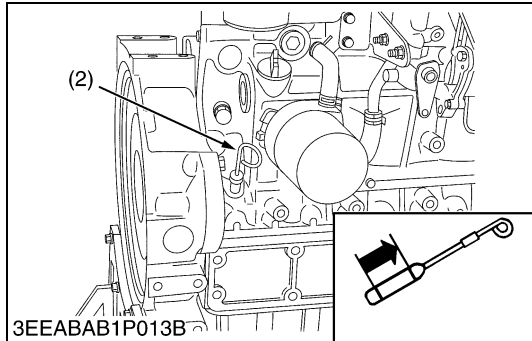
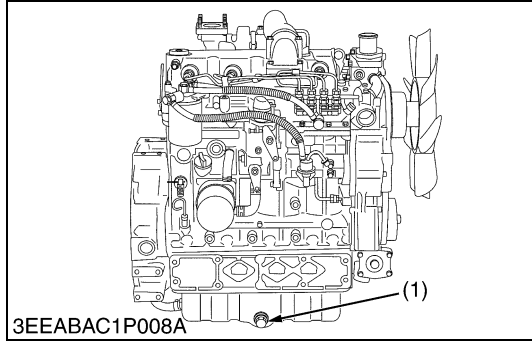

## Changing Engine Oil

### ⚠ CAUTION

- **Be sure to stop engine before changing engine oil.**
- 1. Start and warm up the engine for approx. 5 minutes.
- 2. Place an oil pan underneath the engine.
- 3. To drain the used oil, remove the drain plug (1) at the bottom of the engine and drain the oil completely.
- 4. Screw the drain plug (1).
- 5. Fill new oil up to upper line on the dipstick (2).

### ■ IMPORTANT

- **When using an oil of different maker or viscosity from the previous one, remove all of the old oil.**
- **Never mix two different types of oil.**
- **Engine oil should have properties of API classification CD/CE/CF/CF-4/CG-4.**
- **Use the proper SAE Engine Oil according to ambient temperature.**

Above 25 °C (77 °F)	SAE 30 or SAE 10W-30 SAE 10W-40
0 °C to 25 °C (32 °F to 77 °F)	SAE 20 or SAE 10W-30 SAE 10W-40
Below 0 °C (32 °F)	SAE 10W or SAE 10W-30 SAE 10W-40
Engine oil capacity	13.2 L 3.49 U.S.gals

(1) Drain Plug

(2) Dipstick

W1019006

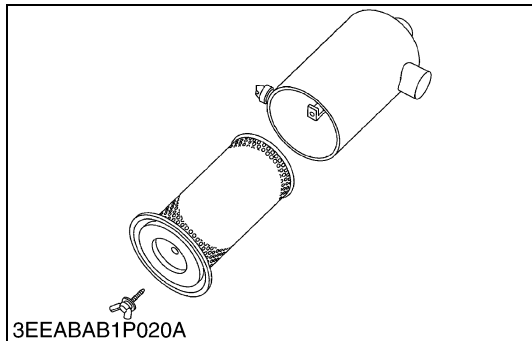

## Replacing Air Cleaner Element

1. Remove used air cleaner element.
2. Replace new air cleaner element.

### ■ NOTE

- **The air cleaner uses a dry element. Never apply oil to it.**
- **Do not run the engine with filter element removed.**

W1020554

## [11] CHECK POINTS OF EVERY 2 YEARS

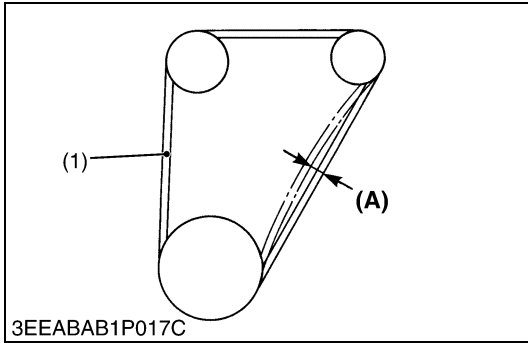

### Replacing Fan Belt

1. Remove the alternator.
2. Remove the fan belt (1).
3. Replace new fan belt.
4. Install the alternator.
5. Check the fan belt tension.

Deflection (A)	Factory spec.	10.0 to 12.0 mm / 98 N 0.394 to 0.472 in. / 98 N (10 kgf, 22 lbs)
----------------	---------------	---

(1) Fan Belt

(A) Deflection

W1019333

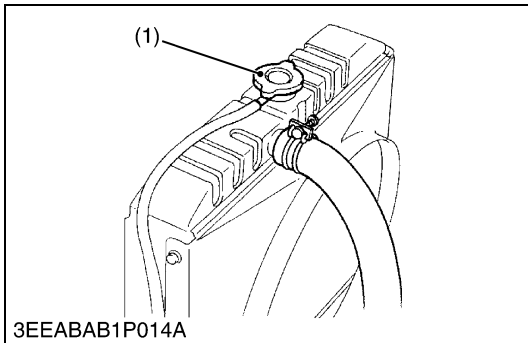

### Changing Radiator Coolant (L.L.C.)

#### ⚠ CAUTION

- Do not remove the radiator cap when the engine is hot. Then loosen cap slightly to the stop to relieve any excess pressure before removing cap completely.

1. Stop the engine and let cool down.
2. To drain the coolant, open the radiator drain plug (2) and remove the radiator cap (1). Then radiator cap (1) must be removed to completely drain the coolant. And open the drain cock of engine body.
3. After all coolant is drained, close the drain plug.
4. Fill with clean water and cooling system cleaner.
5. Follow directions of the cleaner instruction.
6. After flushing, fill with clean water and anti-freeze until the coolant level is just below the port. Install the radiator cap (1) securely.
7. Fill with coolant up to "FULL" (A) mark on the recovery tank (3).
8. Start and operate the engine for few minutes.
9. Stop the engine and let cool. Check coolant level of radiator and recovery tank (3) and add coolant if necessary.

#### ■ IMPORTANT

- Do not start engine without coolant.
- Use clean, fresh, soft water and anti-freeze to fill the radiator and recovery tank.
- When the anti-freeze is mixed with fresh, soft water, the anti-freeze mixing ratio must be less than 50 %.
- Securely tighten radiator cap. If the cap is loose or improperly fitted, water may leak out and the engine could overheat.

- (1) Radiator Cap  
(2) Drain Plug  
(3) Recovery Tank

A : Full

B : Low

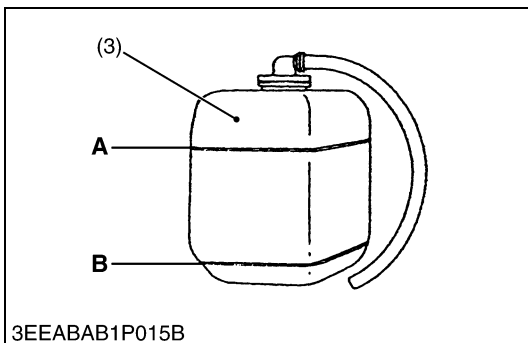
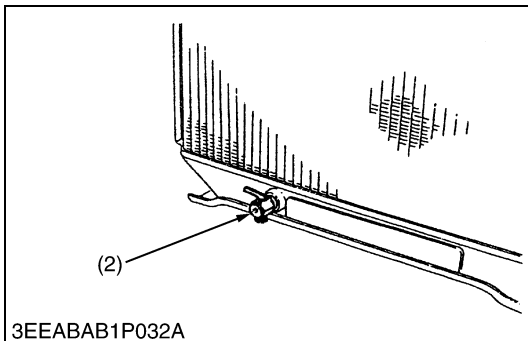

W1024599

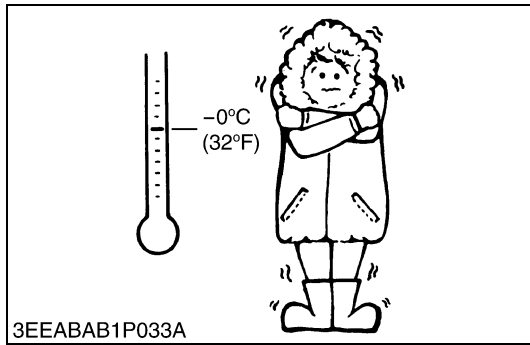

### Changing Radiator Coolant (L.L.C.) (Continued)

#### (Anti-freeze)

- There are two types of anti-freeze available: use the permanent type (PT) for this engine.
- Before adding anti-freeze for the first time, clean the radiator interior by pouring fresh, soft water and draining it a few times.
- The procedure for mixing water and anti-freeze differs according to the make of the anti-freeze and the ambient temperature. Basically, it should be referred to SAE J1034 standard, more specifically also to SAE J814c.
- Mix the anti-freeze with fresh, soft water, and then fill into the radiator.

#### ■ IMPORTANT

- **When the anti-freeze is mixed with fresh, soft water, the anti-freeze mixing ratio must be less than 50 %.**

Vol % anti-freeze	Freezing point		Boiling point*	
	°C	°F	°C	°F
40	-24	-11.2	106	222.8
50	-37	-34.6	108	226.4

\* At 1.013 × 100000 Pa (760 mmHg) pressure (atmospheric). A higher boiling point is obtained by using a radiator pressure cap which permits the development of pressure within the cooling system.

#### ■ NOTE

- The above data represents industrial standards that necessitate a minimum glycol content in the concentrated anti-freeze.
- When the coolant level drops due to evaporation, add fresh, soft water only to keep the anti-freeze mixing ratio less than 50 %. In case of leakage, add anti-freeze and fresh, soft water in the specified mixing ratio.
- Anti-freeze absorbs moisture. Keep unused anti-freeze in a tightly sealed container.
- Do not use radiator cleaning agents when anti-freeze has been added to the coolant.  
(Anti-freeze contains an anti-corrosive agent, which will react with the radiator cleaning agent forming sludge which will affect the engine parts.)

W1024852

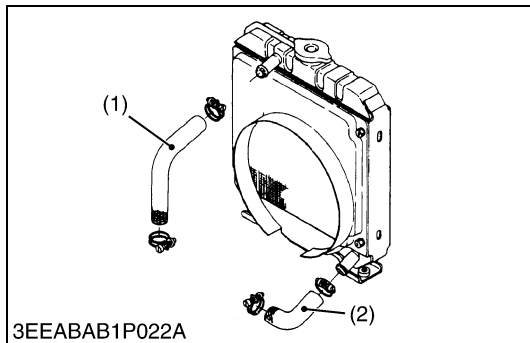

### Replacing Radiator Hoses and Clamp Bands

#### ⚠ CAUTION

- **Do not remove the radiator cap when the engine is hot. Then loosen cap slightly to the stop to relieve any excess pressure before removing cap completely.**

1. Drain the coolant.
2. Loosen the clamp bands.
3. Remove the upper hose (1) and lower hose (2).
4. Replace new upper / lower hose (1), (2) and clamp bands.
5. Tighten the clamp bands.
6. Fill with clean water and anti-freeze until the coolant level is just below the port. Install the radiator cap securely.

(1) Upper Hose

(2) Lower Hose

W1024178

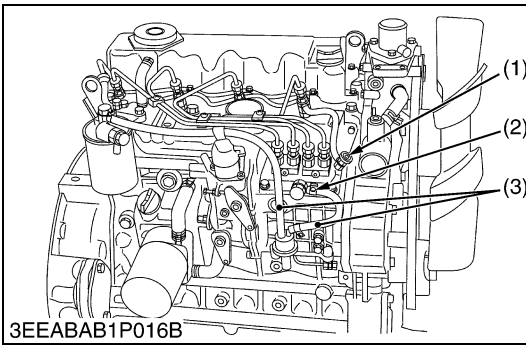

### Replacing Fuel Hose and Clamp Bands

1. Loosen the clamp (2) and remove the fuel hose (3).
2. Replace new fuel hose (3) and new clamp (2).
3. Tighten the clamp (2).

#### **CAUTION**

- **Stop the engine when attempting the check and change prescribed above.**

#### **(When bleeding fuel system)**

1. Fill the tank with fuel and open the cock.
2. Loosen the air vent coupling bolt of fuel filter a few turns.
3. When there is no more air bubbles in the fuel coming out of this coupling bolt, tighten the coupling bolt.
4. Open the air vent cock (1) on the top of fuel injection pump.
5. If equipped electrical fuel feed pump, turn the key on AC position and pump the fuel up for 10 to 15 seconds.  
If equipped mechanical fuel feed pump, set the stop lever on stop position and crank the engine for 10 to 15 seconds.
6. Close securely the air vent cock (1) after air bleeding.

#### **IMPORTANT**

- **Except when venting the air, be sure to keep closed the air vent coupling bolt of the fuel injection pump. Otherwise, the engine may stall.**

(1) Air Vent Cock  
(2) Clamp

(3) Fuel Hose

W1020090

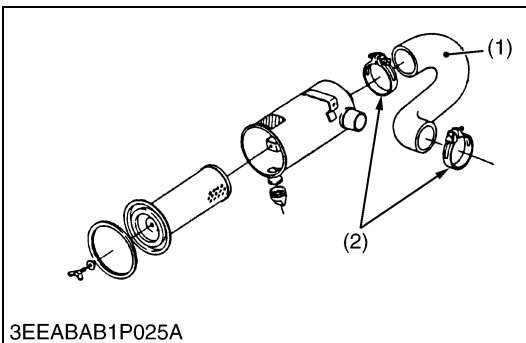

### Replacing Intake Air Line

1. Loosen the clamp (2).
2. Remove the intake air hose (1) and clamp (2).
3. Replace new intake air hose (1) and new clamp (2).
4. Tighten the clamp (2).

#### **NOTE**

- **To prevent serious damage to the engine, keep out any dust inside the intake air line.**

(1) Intake Air Hose

(2) Clamp

W1023867

### Replacing Battery

#### **CAUTION**

- **When the battery is being activated, hydrogen and oxygen gases in the battery are extremely explosive. Keep open sparks and flames away from the battery at all times, especially when charging the battery.**
  - **When charging battery, remove battery vent plugs.**
  - **When disconnecting the cable from the battery, start with the negative terminal first. When connecting the cable to the battery, start with the positive terminal first.**
  - **Never check battery charge by placing a metal object across the posts.**
1. Disconnect the negative terminal and positive terminal.
  2. Remove the battery holder.
  3. Remove the used battery.
  4. Replace the new battery.
  5. Tighten the battery holder.
  6. Connect the positive terminal.
  7. Connect the negative terminal.

W1023996

KiSC issued 06, 2006 A

# 5. SPECIAL TOOLS

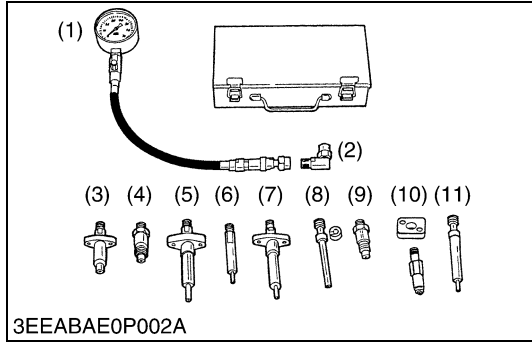

## Diesel Engine Compression Tester

Code No: 07909-30208 (Assembly) 07909-31251 (G)  
 07909-30934 (A to F) 07909-31271 (I)  
 07909-31211 (E and F) 07909-31281 (J)  
 07909-31231 (H)

Application: Use to measure diesel engine compression and diagnosis of need for major overhaul.

- |               |                |
|---------------|----------------|
| (1) Gauge     | (7) Adaptor F  |
| (2) L Joint   | (8) Adaptor G  |
| (3) Adaptor A | (9) Adaptor H  |
| (4) Adaptor B | (10) Adaptor I |
| (5) Adaptor C | (11) Adaptor J |
| (6) Adaptor E |                |

W1024200

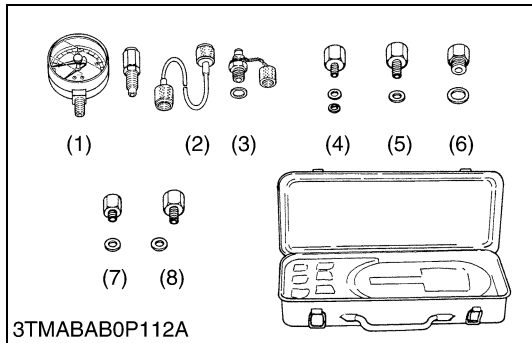

## Oil Pressure Tester

Code No: 07916-32032

Application: Use to measure lubricating oil pressure.

- |                    |               |
|--------------------|---------------|
| (1) Gauge          | (5) Adaptor 2 |
| (2) Cable          | (6) Adaptor 3 |
| (3) Threaded Joint | (7) Adaptor 4 |
| (4) Adaptor 1      | (8) Adaptor 5 |

W1024318

■ **NOTE**

- The following special tools are not provided, so make them referring to the figure.

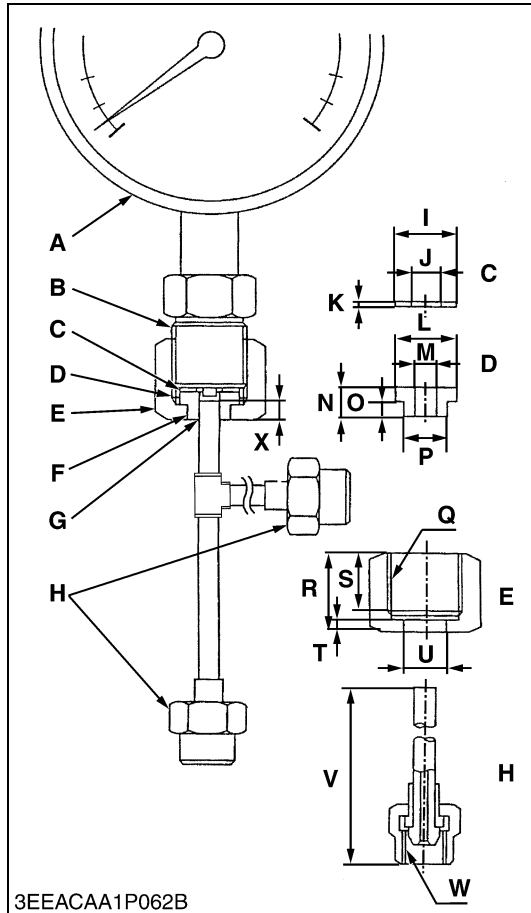

**Injection Pump Pressure Tester**

Application: Use to check fuel tightness of injection pumps.

A	Pressure gauge full scale : More than 29.4 MPa (300 kgf/cm <sup>2</sup> , 4267 psi)
B	PF 1/2
C	Copper gasket
D	Flange (Material : Steel)
E	Hex. nut 27 mm (1.06 in.) across the plat
F	Adhesive application
G	Fillet welding on the enter circumference
H	Retaining nut
I	17 mm dia. (0.67 in. dia.)
J	8 mm dia. (0.31 in. dia.)
K	1.0 mm (0.039 in.)
L	17 mm dia. (0.67 in. dia.)
M	6.10 to 6.20 mm dia. (0.2402 to 0.2441 in. dia.)
N	8 mm (0.31 in.)
O	4 mm (0.16 in.)
P	11.97 to 11.99 mm dia. (0.4713 to 0.4720 in. dia.)
Q	PF 1/2
R	23 mm (0.91 in.)
S	17 mm (0.67 in.)
T	4 mm (0.16 in.)
U	12.00 to 12.02 mm dia. (0.4724 to 0.4732 in. dia.)
V	100 mm (3.94 in.)
W	M12 × P1.5
X	5 mm (0.20 in.)

W10252400

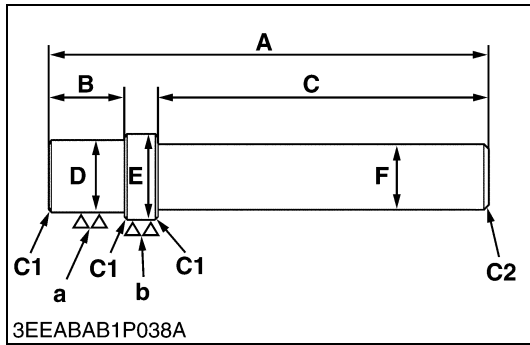

**Small End Bushing Replacing Tool**

Application: Use to press out and to press fit the small end bushing.

**[Press out]**

A	157 mm (6.181 in.)
B	14.5 mm (0.571 in.)
C	120 mm (4.7244 in.)
D	30.0 mm dia. (1.1811 in. dia.)
E	32.95 mm dia. (1.2972 in. dia.)
F	20 mm dia. (0.7874 in. dia.)
a	6.3 μm (250 μin.)
b	6.3 μm (250 μin.)
C1	Chamfer 1.0 mm (0.039 in.)
C2	Chamfer 2.0 mm (0.079 in.)

**[Press fit]**

A	157 mm (6.181 in.)
B	14.5 mm (0.571 in.)
C	120 mm (4.7244 in.)
D	30.0 mm dia. (1.1811 in. dia.)
E	42.000 mm dia. (1.6535 in. dia.)
F	20 mm dia. (0.7874 in. dia.)
a	6.3 μm (250 μin.)
b	6.3 μm (250 μin.)
C1	Chamfer 1.0 mm (0.039 in.)
C2	Chamfer 2.0 mm (0.079 in.)

W1040702

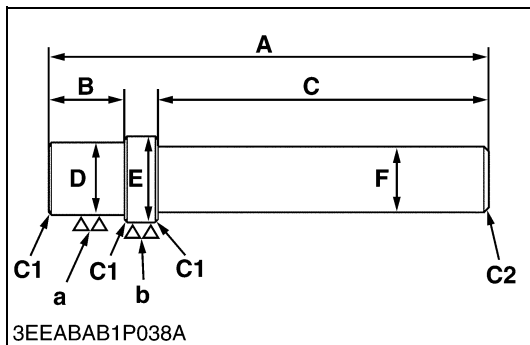

**Idle Gear Bushing Replacing Tool**

Application: Use to press out and to press fit the bushing.

A	196 mm (7.7165 in.)
B	37.5 mm (1.476 in.)
C	150 mm (5.9055 in.)
D	44.95 mm dia. (1.7697 in. dia.)
E	48.075 to 48.100 mm dia. (1.8927 to 1.8937 in. dia.)
F	20 mm dia. (0.7874 in. dia.)
a	6.3 μm (250 μin.)
b	6.3 μm (250 μin.)
C1	Chamfer 1.0 mm (0.039 in.)
C2	Chamfer 2.0 mm (0.079 in.)

W1040289

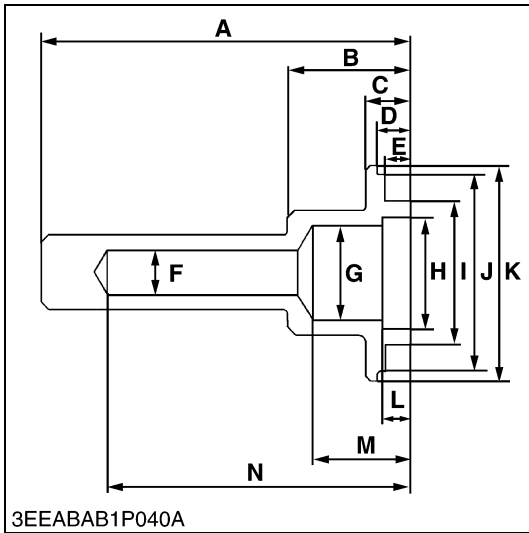

**Gear Case Oil Seal Replacing Tool**

Application: Use to press fit the oil seal.

<b>A</b>	148.8 mm (5.8582 in.)
<b>B</b>	50 mm (1.9685 in.)
<b>C</b>	18.8 mm (0.7401 in.)
<b>D</b>	13.7 to 13.9 mm (0.5394 to 0.5472 in.)
<b>E</b>	11 mm (0.433 in.)
<b>F</b>	18 mm dia. (0.7087 in. dia.)
<b>G</b>	38 mm dia. (1.4961 in. dia.)
<b>H</b>	45 mm dia. (1.7716 in. dia.)
<b>I</b>	57.9 to 58.1 mm dia. (2.2795 to 2.2874 in. dia.)
<b>J</b>	79.5 mm dia. (3.1299 in. dia.)
<b>K</b>	87 mm dia. (3.425 in. dia.)
<b>L</b>	12 mm (0.4724 in.)
<b>M</b>	40 mm (1.5748 in.)
<b>N</b>	120 mm (4.7244 in.)

W1041529



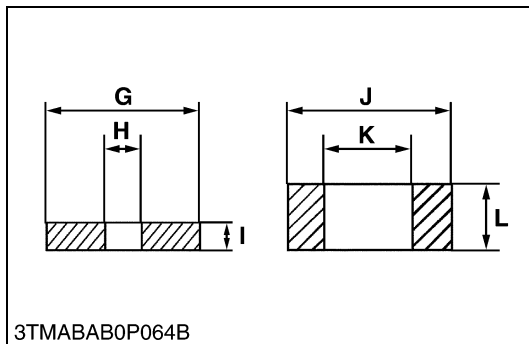
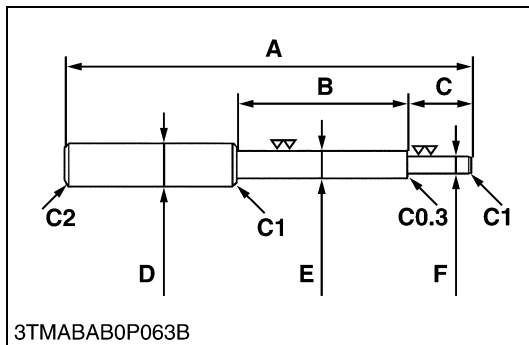

### Valve Guide Replacing Tool

Application: Use to press out and press fit the valve guide.

#### Intake valve guide

A	225 mm (8.86 in.)
B	70 mm (2.76 in.)
C	45 mm (1.77 in.)
D	20 mm dia. (0.79 in dia.)
E	11.7 to 11.9 mm dia. (0.460 to 0.468 in. dia.)
F	6.5 to 6.6 mm dia. (0.256 to 0.259 in. dia.)
G	25 mm dia. (0.98 in. dia.)
H	6.7 to 7.0 mm dia. (0.263 to 0.275 in. dia.)
I	5 mm (0.197 in.)
J	20 mm dia. (0.787 in.dia.)
K	12.5 to 12.8 mm dia. (0.492 to 0.504 in. dia.)
L	8.9 to 9.1 mm (0.350 to 0.358 in.)
C1	Chamfer 1.0 mm (0.039 in.)
C2	Chamfer 2.0 mm (0.079 in.)
C0.3	Chamfer 0.3 mm (0.012 in.)

#### Exhaust valve guide

A	225 mm (8.86 in.)
B	80 mm (3.15 in.)
C	40 mm (1.57 in.)
D	20 mm dia. (0.79 in dia.)
E	12.96 to 12.98 mm dia. (0.510 to 0.511 in. dia.)
F	7.50 to 7.70 mm dia. (0.295 to 0.303 in. dia.)
G	14.5 to 15.5 mm dia. (0.57 to 0.61 in.dia.)
H	8.0 to 8.1 mm dia. (0.31 to 0.32 in. dia.)
I	5 mm (0.197 in.)
J	17.5 to 18.5 mm dia. (0.689 to 0.728 in. dia.)
K	13.1 to 13.2 mm dia. (0.516 to 0.520 in. dia.)
L	9.9 to 10.1 mm (0.390 to 0.398 in.)
C1	Chamfer 1.0 mm (0.039 in.)
C2	Chamfer 2.0 mm (0.079 in.)
C0.3	Chamfer 0.3 mm (0.012 in.)

W1038887

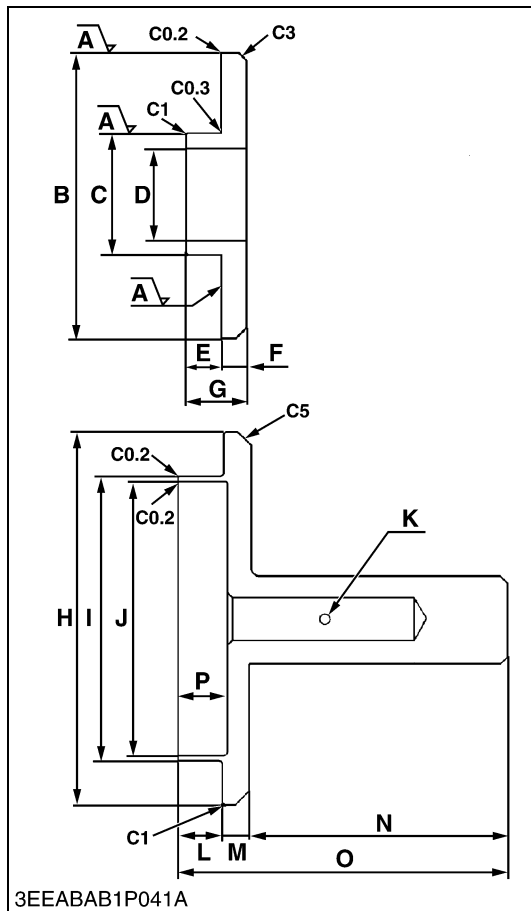

### Auxiliary Socket for Fixing Crankshaft Sleeve

Application: Use to fix the crankshaft sleeve of the diesel engine.

A	Rmax = 12.5 S
B	94.5 to 95.0 mm dia. (3.7205 to 3.7402 in. dia.)
C	40 mm dia. (1.5748 in. dia.)
D	30 mm dia. (1.1811 in. dia.)
E	12 mm (0.4724 in.)
F	7.9 to 8.1 mm (0.3110 to 0.3189 in.)
G	20 mm (0.7874 in.)
H	130 mm dia. (5.1181 in. dia.)
I	99.4 to 99.6 mm dia. (3.9134 to 3.9213 in. dia.)
J	95.05 to 95.20 mm dia. (3.7421 to 3.7480 in. dia.)
K	3 mm dia. (0.1181 in. dia.)
L	15 mm (0.5905 in.)
M	10 mm (0.3937 in.)
N	90 mm (3.5433 in.)
O	115 mm (4.5275 in.)
P	16.9 to 17.1 mm (0.6654 to 0.6732 in.)
C1	Chamfer 1.0 mm (0.039 in.)
C3	Chamfer 3.0 mm (0.1181 in.)
C5	Chamfer 5.0 mm (0.1969 in.)
C0.2	Chamfer 0.2 mm (0.0079 in.)
C0.3	Chamfer 0.3 mm (0.0118 in.)

W1041815

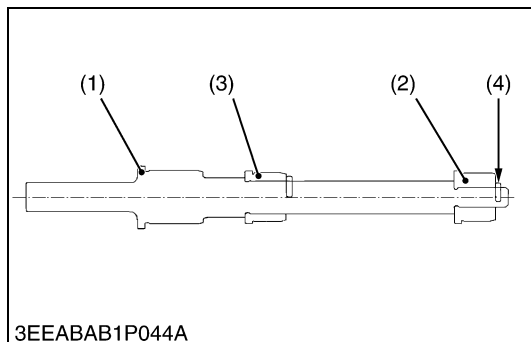

### Balancer Bushing Replacing Tool 1 Assembly

Application: Use to press fit the bushing.

No.	Name of Part	Q'ty.	Remarks
(1)	Shaft	1	
(2)	Piece 1	1	
(3)	Piece 2	1	
(4)	Bolt	2	M6 × P1.0

W1042867

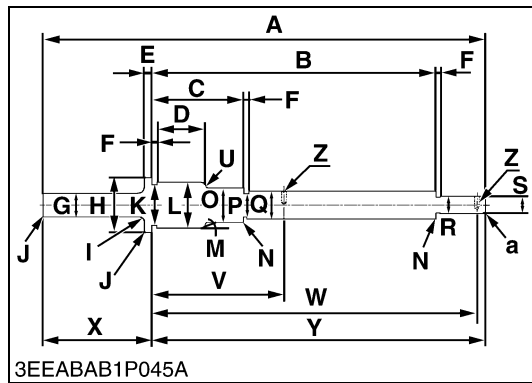

**Balancer Bushing Replacing Tool 1 Components Parts**

**1) Shaft**

A	498 mm (19.61 in.)
B	318.8 to 319.2 mm (12.5512 to 12.5669 in.)
C	102.8 to 103.2 mm (4.0472 to 4.0630 in.)
D	60 mm (2.36 in.)
E	8 mm (0.31 in.)
F	5 mm (0.20 in.)
G	30 mm dia. (1.18 in. dia.)
H	65 mm dia. (2.56 in. dia.)
I	6 mm (0.24 in.)
J	Chamfer 1 mm (0.04 in.)
K	53 mm dia. (2.09 in. dia.)
L	54.7 to 54.9 mm dia. (2.1535 to 2.1614 in. dia.)
M	0.26 rad (15 °)
N	Chamfer 0.5 mm (0.02 in.)
O	41 mm dia. (1.61 in. dia.)
P	32 mm dia. (1.26 in. dia.)
Q	33.96 to 34.0 mm dia. (1.3370 to 1.3386 in. dia.)
R	18 mm dia. (0.71 in. dia.)
S	19.967 to 20.0 mm dia. (0.7861 to 0.7874 in. dia.)
U	3 mm (0.12 in.)
V	149.1 to 149.4 mm (5.8701 to 5.8819 in.)
W	365.1 to 365.4 mm (14.3740 to 14.3858 in.)
X	123 mm (4.84 in.)
Y	375 mm (14.76 in.)
Z	M6 × P1.0 depth 7 mm (0.28 in.)
a	Chamfer 2 mm (0.08 in.)

W1043162

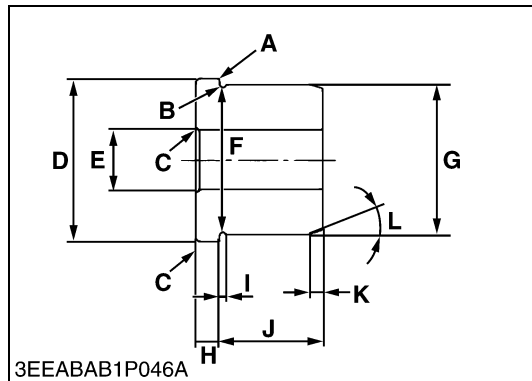

**2) Piece 1**

A	Chamfer 0.1 mm (0.004 in.)
B	1 mm (0.04 in.)
C	Chamfer 1mm (0.04 in.)
D	53.8 to 53.9 mm dia. (2.1181 to 2.1220 in. dia.)
E	20.02 to 20.041 mm dia. (0.7882 to 0.7890 in. dia.)
F	48 mm dia. (1.89 in. dia.)
G	49.934 to 49.94 mm dia. (1.9659 to 1.9661 in. dia.)
H	8 mm (0.31 in.)
I	2 mm (0.08 in.)
J	35 mm dia. (1.38 in. dia.)
K	5 mm (0.20 in.)
L	0.26 rad (15 °)

W1044434

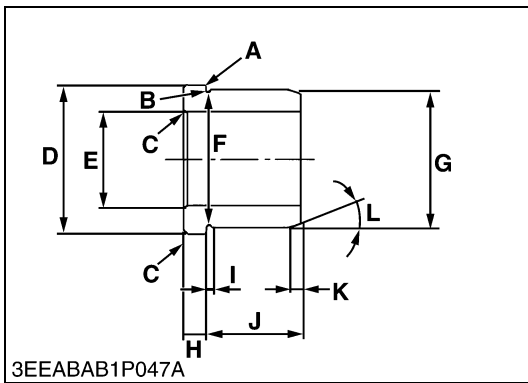

**3) Piece 2**

A	Chamfer 0.1 mm (0.004 in.)
B	1 mm (0.04 in.)
C	Chamfer 1mm (0.04 in.)
D	54.3 to 54.4 mm dia. (2.1378 to 2.1417 in. dia.)
E	34.025 to 34.05 mm dia. (1.3396 to 1.3406 in. dia.)
F	48.5 mm dia. (1.9094 in. dia.)
G	50.421 to 50.44 mm dia. (1.9851 to 1.9858 in. dia.)
H	8 mm (0.31 in.)
I	2 mm (0.08 in.)
J	35 mm dia. (1.38 in. dia.)
K	5 mm (0.20 in.)
L	0.26 rad (15 °)

W1044620

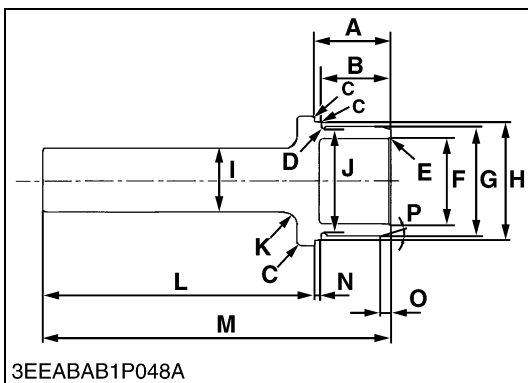

**Balancer Bushing Replacing Tool 2**

Application: Use to press fit the bushing.

A	35 mm (1.38 in.)
B	33 mm (1.30 in.)
C	Chamfer 0.5 mm (0.02 in.)
D	1 mm (0.04 in.)
E	Chamfer 1 mm (0.04 in.)
F	40 mm dia. (1.57 in. dia.)
G	50.921 to 50.94 mm dia. (2.0048 to 2.0055 in. dia.)
H	54.8 to 54.9 mm dia. (2.1575 to 2.1614 in. dia.)
I	30 mm dia. (1.18 in. dia.)
J	49 mm dia. (1.93 in. dia.)
K	6 mm (0.24 in.)
L	125 mm (4.92 in.)
M	160 mm (6.30 in.)
N	3 mm (0.12 in.)
O	5 mm (0.20 in.)
P	0.26 rad (15 °)

W1044794

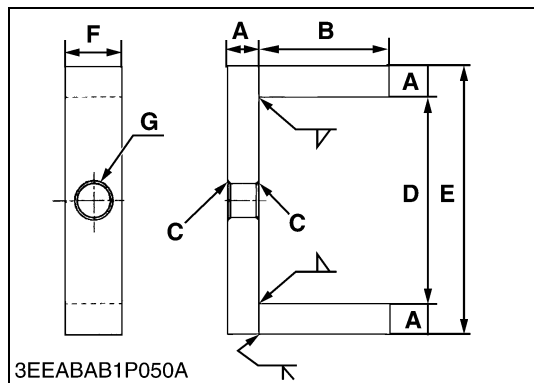
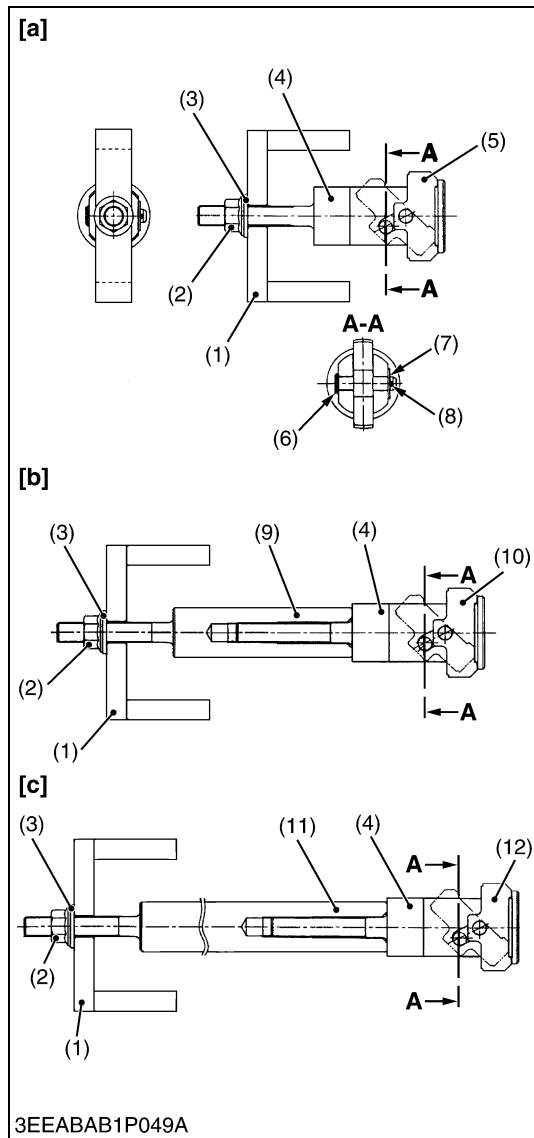

**Balancer Replacing Tools 3, 4, 5**

Application: Use to press fit the bushing.

■ **NOTE**

- This special tool is not provided, so make it referring to the figure.

No.	Name of Part	Q'ty.
(1)	Bracket	1
(2)	Flange Nut	1
(3)	Washer	1
(4)	Shaft	1
(5)	Piece 1	1
(6)	Clevis	1
(7)	Washer	1
(8)	Cotter Pin	1
(9)	Joint 1	1
(10)	Piece 2	1
(11)	Joint 2	1
(12)	Piece 3	1

[a] : Tool 3  
[b] : Tool 4

[c] : Tool 5  
A : Section

W1045310

**Balancer Replacing Tool Components Parts**

**1) Bracket**

A	12 mm (0.47 in.)
B	50 mm (1.97 in.)
C	Chamfer 1 mm (0.04 in.)
D	80 mm (3.15 in.)
E	104 mm (4.09 in.)
F	22 mm (0.87 in.)
G	13 mm dia. (0.51 in. dia.)

W1167794

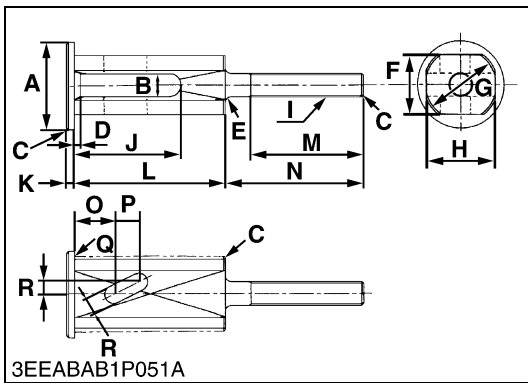

## 2) Shaft

A	44 mm dia. (1.73 in. dia.)
B	12 mm (0.47 in.)
C	Chamfer 1 mm (0.04 in.)
D	3 mm (0.12 in.)
E	3 mm (0.12 in.)
F	30 mm (1.18 in.)
G	38 mm (1.50 in.)
H	35 mm (1.38 in.)
I	M12 × P1.25
J	53 mm (2.09 in.)
K	4 mm (0.16 in.)
L	75 mm (2.95 in.)
M	57 mm (2.24 in.)
N	70 mm (2.76 in.)
O	19.5 mm (0.77 in.)
P	12 mm (0.47 in.)
Q	0.8 mm (0.03 in.)
R	6 mm (0.24 in.)

W1046146

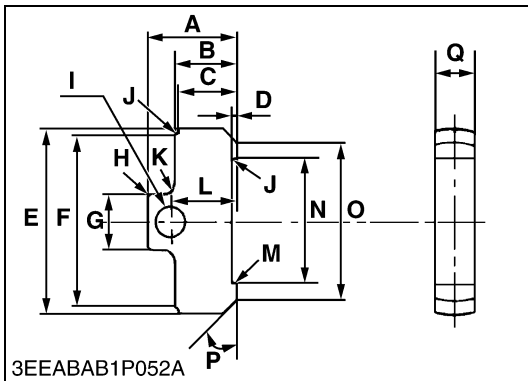

## 3) Piece 1

A	26 mm (1.02 in.)
B	18 mm (0.71 in.)
C	16.5 to 17.0 mm (0.6496 to 0.6693 in.)
D	1.5 mm (0.06 in.)
E	54.0 to 54.2 mm dia. (2.1260 to 2.1339 in dia.)
F	50.55 to 50.75 mm dia. (1.9902 to 1.9980 in dia.)
G	16 mm (0.63 in.)
H	Chamfer 1 mm (0.04 in.)
I	8.5 mm dia. (0.33 in. dia.)
J	0.4 mm (0.0157 in.)
K	3 mm (0.12 in.)
L	19 mm (0.75 in.)
M	Chamfer 0.5 mm (0.02 in.)
N	36 mm (1.42 in.)
O	45 mm dia. (1.77 in. dia.)
P	0.78 rad (45 °)
Q	11.5 mm (0.45 in.)

W1047263

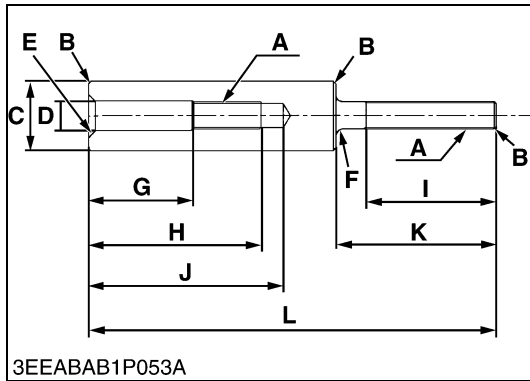

4) Joint 1

A	M12 × P1.25
B	Chamfer 1 mm (0.04 in.)
C	30 mm dia. (1.18 in. dia.)
D	13 mm dia. (0.51 in. dia.)
E	Chamfer 3 mm (0.12 in.)
F	3 mm (0.12 in.)
G	45 mm (1.77 in.)
H	75 mm (2.95 in.)
I	57 mm (2.24 in.)
J	85 mm (3.35 in.)
K	70 mm (2.76 in.)
L	178 mm (7.01 in.)

W1047709

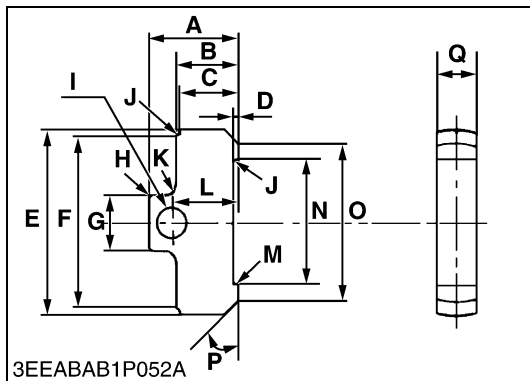

5) Piece 2

A	26 mm (1.02 in.)
B	18 mm (0.71 in.)
C	16.5 to 17.0 mm (0.6496 to 0.6693 in.)
D	1.5 mm (0.06 in.)
E	53.5 to 53.7 mm dia. (2.1063 to 2.1142 in dia.)
F	50.05 to 50.25 mm dia. (1.9705 to 1.9783 in dia.)
G	16 mm (0.63 in.)
H	Chamfer 1 mm (0.04 in.)
I	8.5 mm dia. (0.33 in. dia.)
J	0.4 mm (0.0157 in.)
K	3 mm (0.12 in.)
L	19 mm (0.75 in.)
M	Chamfer 0.5 mm (0.02 in.)
N	36 mm (1.42 in.)
O	45 mm dia. (1.77 in. dia.)
P	0.78 rad (45 °)
Q	11.5 mm (0.45 in.)

W1048068

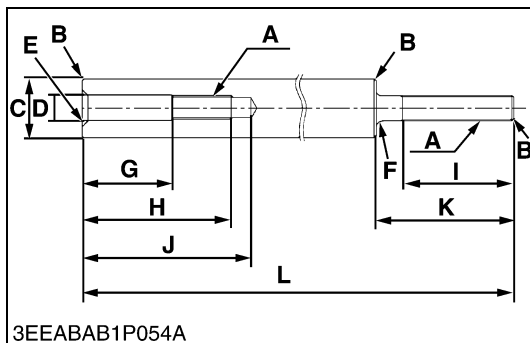

6) Joint 2

A	M12 × P1.25
B	Chamfer 1 mm (0.04 in.)
C	30 mm dia. (1.18 in. dia.)
D	13 mm dia. (0.51 in. dia.)
E	Chamfer 3 mm (0.12 in.)
F	3 mm (0.12 in.)
G	45 mm (1.77 in.)
H	75 mm (2.95 in.)
I	57 mm (2.24 in.)
J	85 mm (3.35 in.)
K	70 mm (2.76 in.)
L	394 mm (15.51 in.)

W1048305

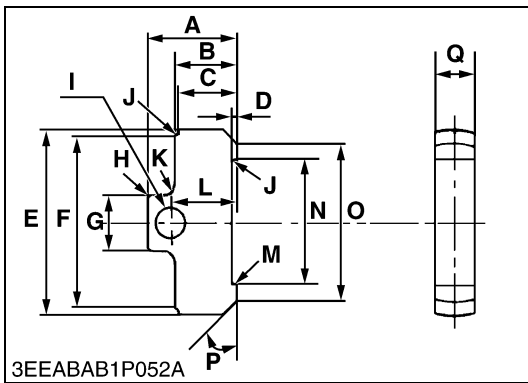

7) Piece 3

A	26 mm (1.02 in.)
B	18 mm (0.71 in.)
C	16.5 to 17.0 mm (0.6496 to 0.6693 in.)
D	1.5 mm (0.06 in.)
E	53.0 to 53.2 mm dia. (2.0866 to 2.0945 in dia.)
F	49.55 to 49.75 mm dia. (1.9508 to 1.9587 in dia.)
G	16 mm (0.63 in.)
H	Chamfer 1 mm (0.04 in.)
I	8.5 mm dia. (0.33 in. dia.)
J	0.4 mm (0.0157 in.)
K	3 mm (0.12 in.)
L	19 mm (0.75 in.)
M	Chamfer 0.5 mm (0.02 in.)
N	36 mm (1.42 in.)
O	45 mm dia. (1.77 in. dia.)
P	0.78 rad (45 °)
Q	11.5 mm (0.45 in.)

W1048484

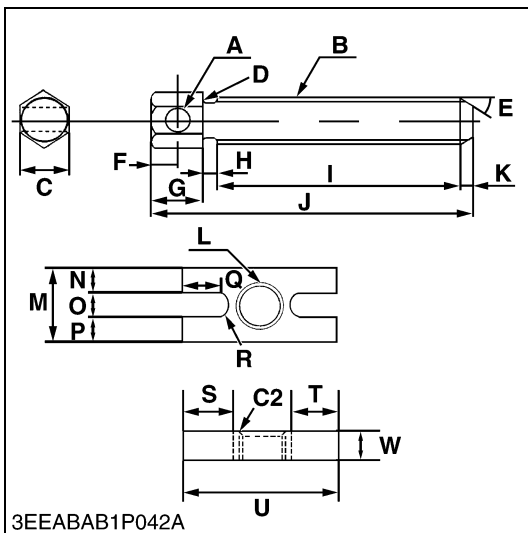

**Injection Pump Gear Puller**

Application: Use for remove the injection pump gear from governor shaft.

A	10 mm dia. (0.39 in.dia.)
B	M16 × Pitch 1.5
C	19 mm (0.75 in.)
D	0.5 mm radius (0.02 in. radius)
E	0.87 rad (50 °)
F	10 mm (0.39 in.)
G	20 mm (0.79 in.)
H	5 mm (0.20 in.)
I	95 mm (3.74 in.)
J	125 mm (4.92 in.)
K	5 mm (0.20 in.)
L	M16 × Pitch 1.5
M	30 mm (1.18 in.)
N	9.5 mm (0.3740 in.)
O	11 mm (0.4331 in.)
P	9.5 mm (0.3740 in.)
Q	14.5 mm (0.57 in.)
R	5.5 mm radius (0.22 in. radius)
S	20 mm (0.79 in.)
T	20 mm (0.79 in.)
U	80 mm (3.1496 in.)
W	12 mm (0.47 in.)
C2	Chamfer 2.0 mm (0.079 in.)

W1042094



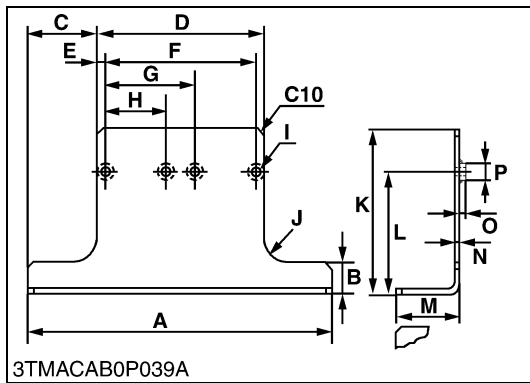

**Engine Stand**

Application: Use to support engine.

A	480 mm (18.90 in.)
B	50 mm (1.97 in.)
C	108.5 mm (4.272 in.)
D	262.5 mm (10.33 in.)
E	12.5 mm (0.492 in.)
F	237.5 mm (9.350 in.)
G	142.5 mm (5.610 in.)
H	95 mm (3.74 in.)
I	14 mm dia. (0.55 in. dia.)
J	40 mm radius (1.57 in. radius)
K	210 mm (8.27 in.)
L	190 mm (7.48 in.)
M	100 mm (3.94 in.)
N	6 mm (0.24 in.)
O	6 mm (0.24 in.)
P	25 mm dia. (0.98 in. dia.)
C10	Chamfer 10 mm (0.394 in.)

W1033645

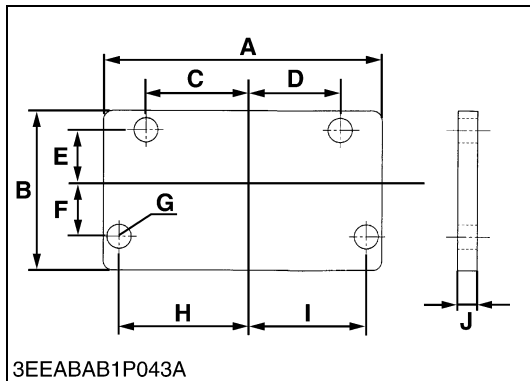

**Flywheel Stopper (for SAE Flywheel and Housing)**

Application: Use to loosen and tighten the flywheel screw.

A	140 mm (5.5 in.)
B	80 mm (3.15 in.)
C	49.3 mm (1.94 in.)
D	49.3 mm (1.94 in.)
E	23.8 mm (0.94 in.)
F	23.8 mm (0.94 in.)
G	11 mm dia. (0.43 in. dia.)
H	56.5 mm (2.22 in.)
I	56.5 mm (2.22 in.)
J	8 mm (0.31 in.)

W1042515

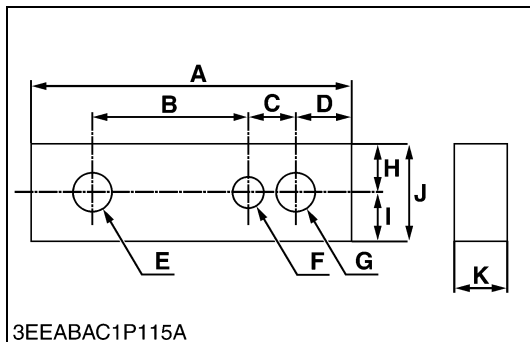

**Tool for Aligning the Crankcase 1 and 2**

Application: Use for aligning the crankcase 1 and 2.

A	115 mm (4.5276 in.)
B	56 mm (2.2047 in.)
C	17 mm (0.6693 in.)
D	20 mm (0.7874 in.)
E	14 mm dia. (0.5512 in. dia.)
F	11 mm dia. (0.4331 in. dia.)
G	14 mm dia. (0.5512 in. dia.)
H	17.5 mm (0.6890 in.)
I	17.5 mm (0.6890 in.)
J	35 mm (1.3780 in.)
K	19 mm (0.7480 in.)

W1047882

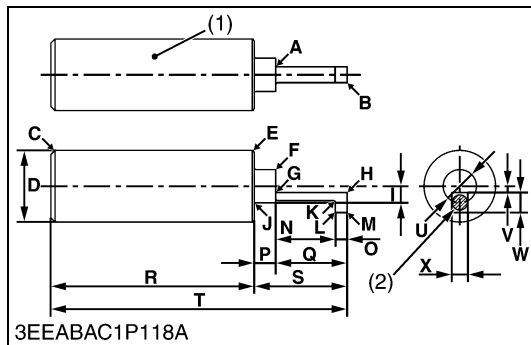

### Jig for Governor Connecting Rod

Application: Use for connecting the governor connecting rod to the rack pin of the fuel injection pump assembly.

A	1 mm radius (0.0394 in. radius)
B	Chamfer 0.2 mm (0.0079 in.)
C	Chamfer 2 mm (0.0787 in.)
D	35 mm dia. (1.3780 in. dia.)
E	Chamfer 1 mm (0.0394 in.)
F	Chamfer 0.1 mm (0.0039 in.)
G	1 mm radius (0.0394 in. radius)
H	Chamfer 0.2 mm (0.0079 in.)
I	8 mm radius (0.3150 in. radius)
J	1 mm radius (0.0394 in. radius)
K	1 mm radius (0.0394 in. radius)
L	Chamfer 0.2 mm (0.0079 in.)
M	Chamfer 0.2 mm (0.0079 in.)
N	29 mm (1.1417 in.)
O	6 mm (0.2362 in.)
P	10.7 mm (0.4213 in.)
Q	35 mm (1.3780 in.)
R	99.3 mm (3.9095 in.)
S	45.65 to 45.75 mm (1.7972 to 1.8012 in.)
T	145 mm (5.7087 in.)
U	16.15 to 16.35 mm (0.6358 to 0.6437 in.)
V	3 mm (0.1181 in.)
W	10 mm (0.3937 in.)
X	8 mm (0.3150 in.)

(1) Material: S45C-D

(2) Permanent Magnet: 8 mm dia.  
(0.3150 in. dia.)  
Thickness: 3 mm (0.1181 in.)

W1115114

# MECHANISM

## CONTENTS

1. FEATURE .....	M-1
2. ENGINE BODY .....	M-2
[1] CYLINDER BLOCK.....	M-2
[2] HALF-FLOATING HEAD COVER.....	M-2
[3] CYLINDER HEAD.....	M-3
[4] PISTON AND PISTON RINGS .....	M-3
[5] BUILT-IN DYNAMIC BALANCER (BALANCER MODEL ONLY).....	M-4
3. LUBRICATING SYSTEM .....	M-5
[1] OIL COOLER .....	M-5
4. COOLING SYSTEM.....	M-6
[1] THERMOSTAT .....	M-6
[2] BOTTOM BYPASS SYSTEM.....	M-7
5. FUEL SYSTEM .....	M-8
[1] GOVERNOR .....	M-8
6. TURBOCHARGER SYSTEM.....	M-11
[1] BOOST COMPENSATOR .....	M-11

# 1. FEATURE

**V3300-E2B**

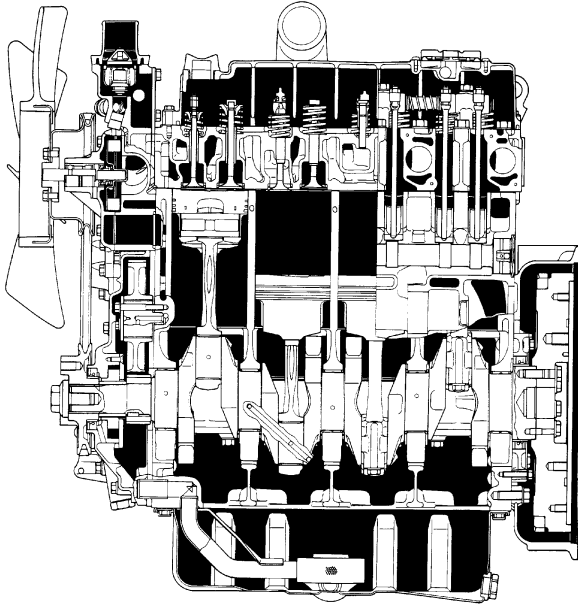

3EEABAB1P001B

**V3300-T-E2B**

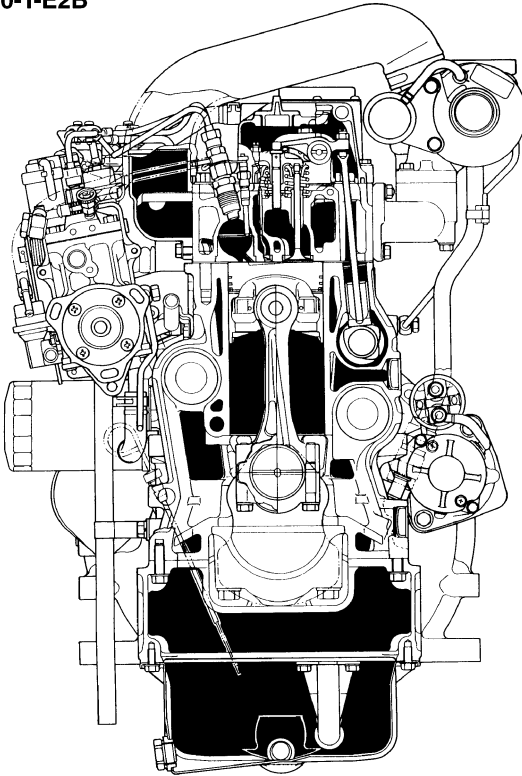

3EEABAB1P002B

V3 series IDI engine is the vertical type 4-cycle diesel engine featuring the advanced performances shown below.

This is a small sized, high power and environment conscious engine, which employs the three valve system, two inlet valves with double ports, and one exhaust valve with the new E-TVCS VERSION-II. Thus, this engine achieves high combustion efficiency and complies with various regulations of exhaust gas.

Based upon the conventional model, Kubota developed a unique governor system and various new mechanisms which reduces exhaust emission, noise and vibration and realize durability and high torque.

W1013043

## 2. ENGINE BODY

### [1] CYLINDER BLOCK

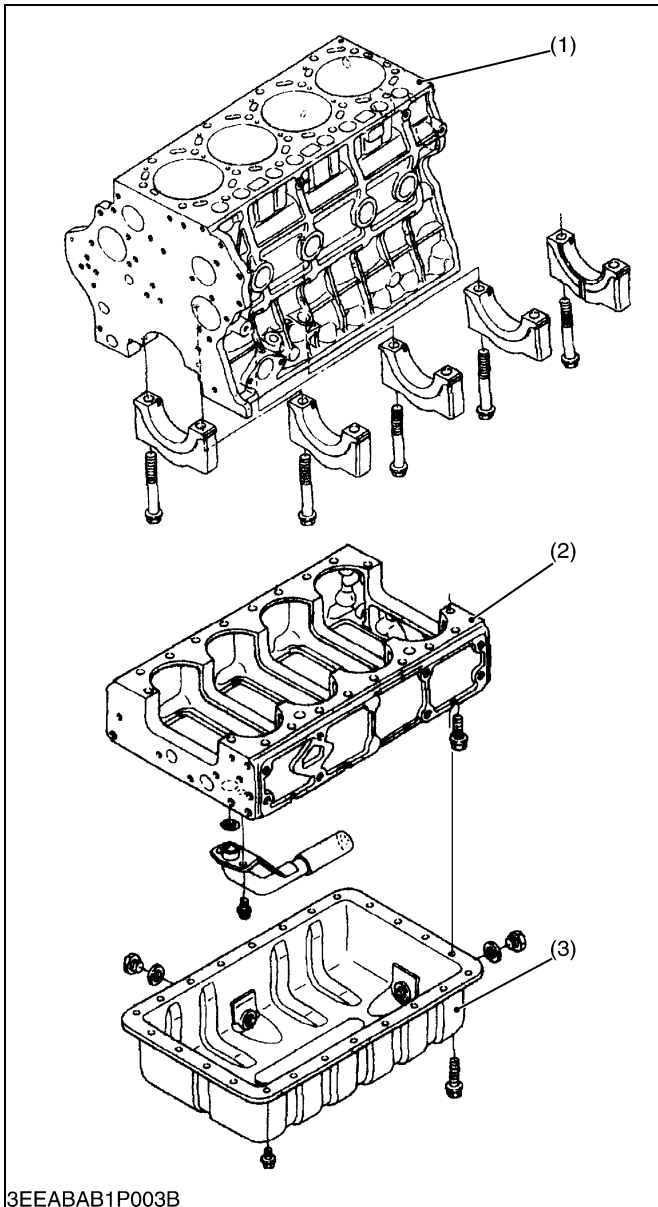

This engine employs separate type crankcases - the crankcase 1 (1) with combustion part and the crankcase 2 (2) which supports the crankcase 1 (1) and reduces noise.

Since it is a hanger type, you can easily assemble / disassemble it. The cylinder is a linerless type which enables good cooling operation, less strain and good abrasion resistance.

- (1) Crankcase 1
- (2) Crankcase 2

- (3) Oil Pan

W1013119

### [2] HALF-FLOATING HEAD COVER

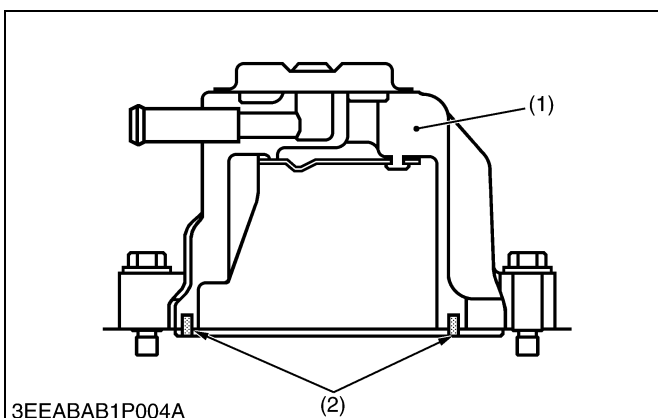

The rubber packing is fitted in to maintain the head cover 0.5 mm (0.02 in.) or so off the cylinder head. This arrangement helps reduce noise coming from the cylinder head.

- (1) Cylinder Head Cover

- (2) Rubber Packing

W1013327

### [3] CYLINDER HEAD

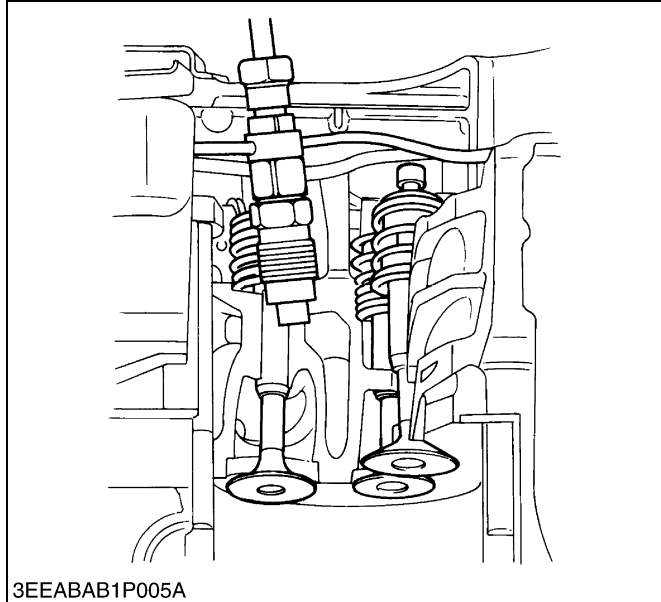

This engine employs three valve system - two inlet valves and double ports, and one exhaust valve which produce good inlet inertia to improve combustion efficiency and volumetric efficiency. It also employs Kubota's unique combustion chamber with multiple injection grooves.

Besides the conventional cross port system, it employs the forced cooling method between valves to eliminate heat distortion, thus enabling durable and reliable configuration.

W1013336

### [4] PISTON AND PISTON RINGS

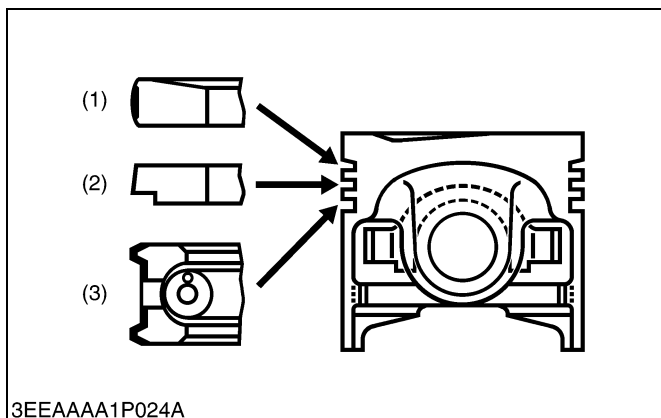

This engine employs the E-TVCS VERSION-II so that the improved combustion surface at the top of piston enables more complete combustion efficiency than the conventional models.

The profile and the offset of piston are optimized to reduce slapping noises. The oil jet at the small end of the connecting rod reduces heat load of the piston.

Three rings are installed in grooves in the piston. The top ring (1) is made of nitriding steel to get more reliability than the chrome plated ring. It is a keystone type ring to get durability against heavy load. At the sliding part, a special piston ring which is conformable to the cylinder wall is employed. The second ring is chrome plated on the peripheral surface and it is an undercut ring to prevent shortage of oil.

The oil ring (3) has chamfered contact faces and an expander ring, which increase the pressure of the oil ring against the cylinder wall.

Several grooves are cut on the topland to help heat dissipate and to prevent scuffing.

- |                 |                  |
|-----------------|------------------|
| (1) Top Ring    | (4) Depression   |
| (2) Second Ring | (5) Valve Recess |
| (3) Oil Ring    |                  |

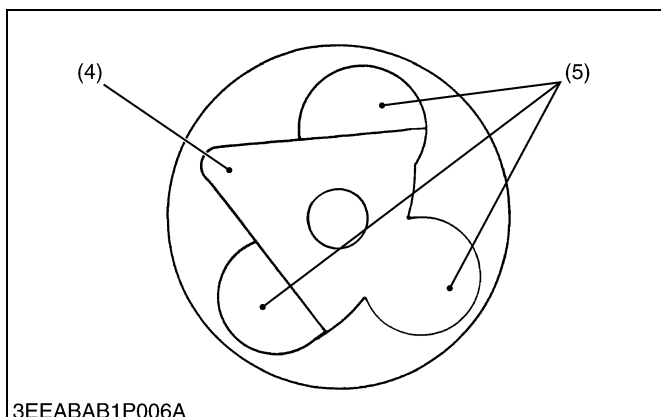

W1013501

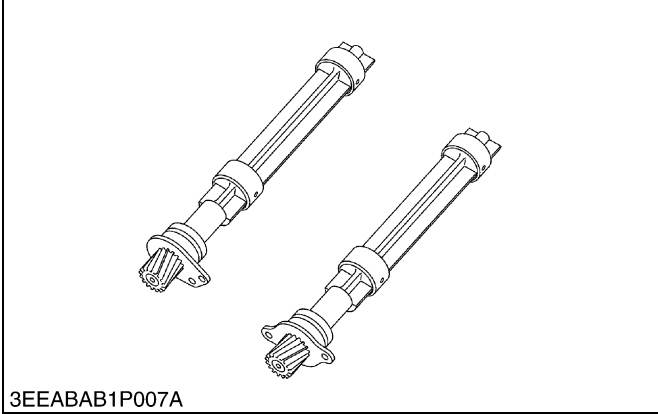
**[5] BUILT-IN DYNAMIC BALANCER (BALANCER MODEL ONLY)**

Engines are sure to vibrate by piston's reciprocation. Theoretically, three-cylinder engines are much less prone to cause vibration than four-cylinder ones (second inertia, etc.). However, any engine has many moving parts in addition to its pistons and cannot be completely free from vibration.

The four cylinder engine is fitted with balance weight on crankcase to absorb the second inertia mentioned above and reduce vibration.

W1013617

### 3. LUBRICATING SYSTEM

#### [1] OIL COOLER

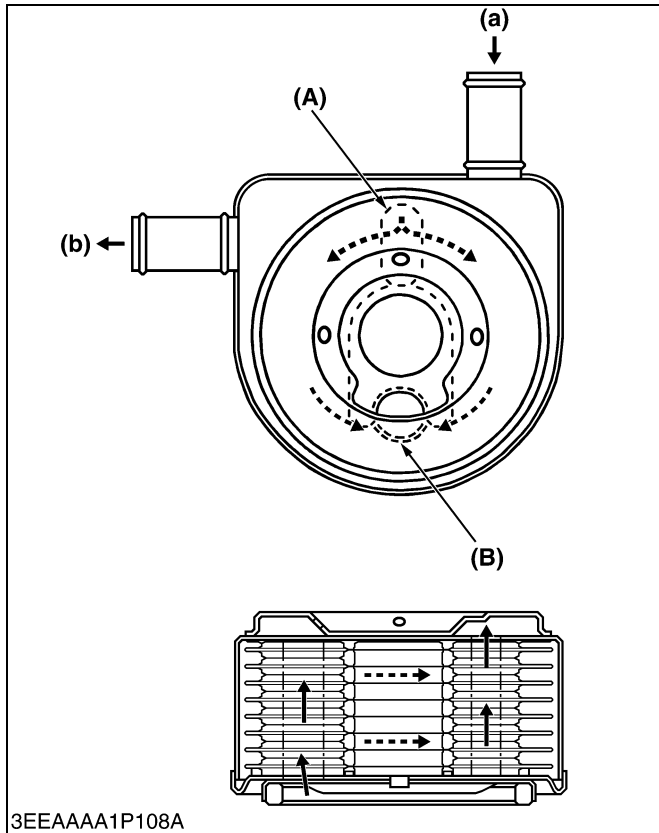

V3 series engine has a water-cooled oil cooler that not only cools hot oil, but also warms the cool engine oil shortly after start up.

As shown in the figure, the oil flows inside the connected cooler plate, whereas coolant is kept circulating outside the cooler plate, thereby cooling down or warming the oil.

(A) Oil Inlet Port  
(B) Oil Outlet Port

(a) Coolant Inlet Port  
(b) Coolant Outlet Port

W10344770



# 4. COOLING SYSTEM

## [1] THERMOSTAT

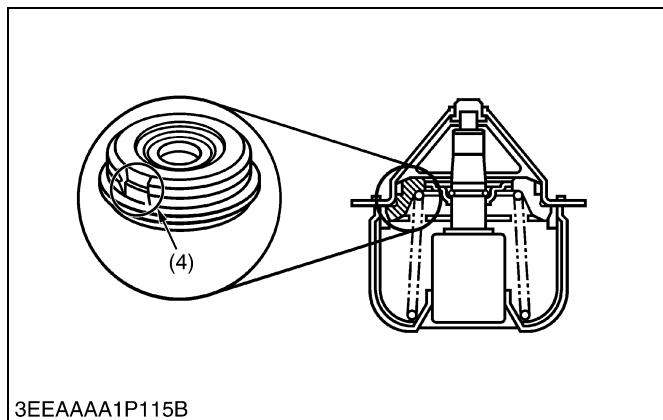
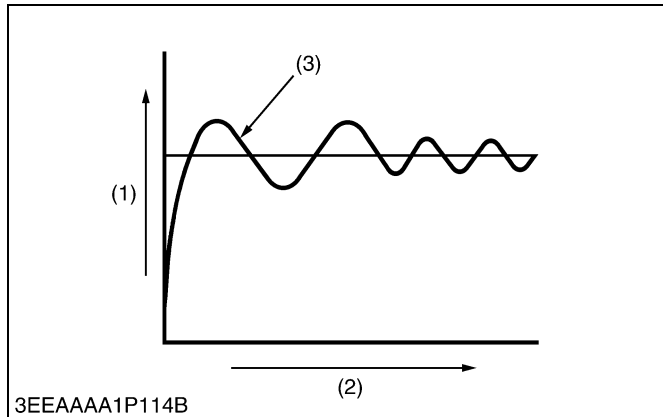

Conventional thermostatically-controlled valves (outlet water temperature control type) open against the flow of coolant. In this design, the pressure (steam pressure + water pump's discharge pressure) affects the open/close performance of such valve. In other words, the valve may be delayed in opening at a preset opening temperature opening suddenly, above the preset temperature. This is called the overshoot phenomenon.

The overshoot problem invites the undershoot phenomenon too. Too much water cooled by the radiator flows through the water passage, which suddenly closes the valve below the thermostat's preset valve closing temperature.

A repeated cycle of such overshoot and undershoot phenomena is called the water temperature hunting. This hunting problem may adversely affects the cooling system parts, and also the engine and its related components.

To cope with this trouble, the V3 series engine is equipped with the flow control thermostat. The valve has a notch to control the coolant flowrate smoothly in small steps.

- (1) Coolant Temperature
- (2) Time
- (3) Overshoot
- (4) Notch

- (A) Valve Lift Versus Flowrate
- (B) Flowrate
- (C) At Short Valve Lift
- (D) At Medium Valve Lift
- (E) At High Valve Lift
- (F) Valve Lift

W1013684

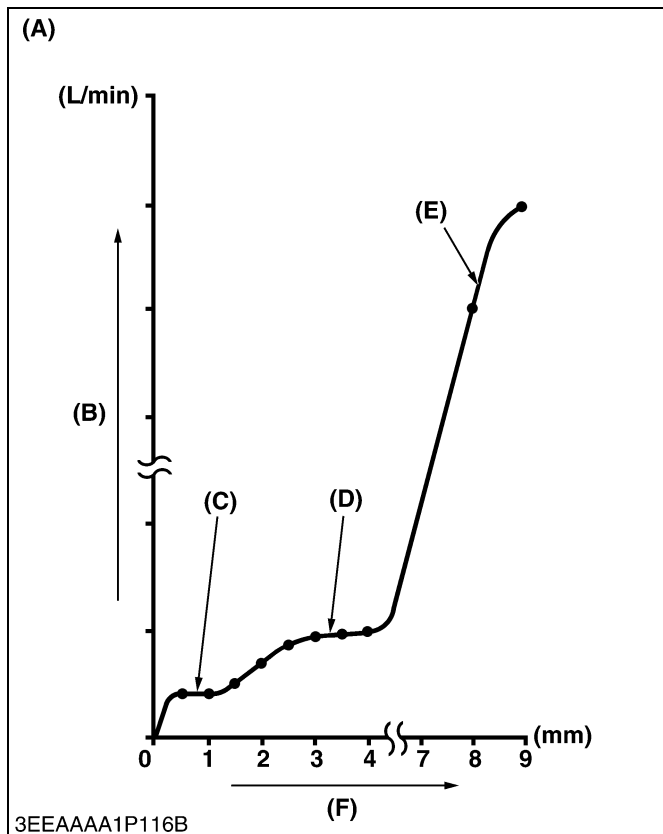

## [2] BOTTOM BYPASS SYSTEM

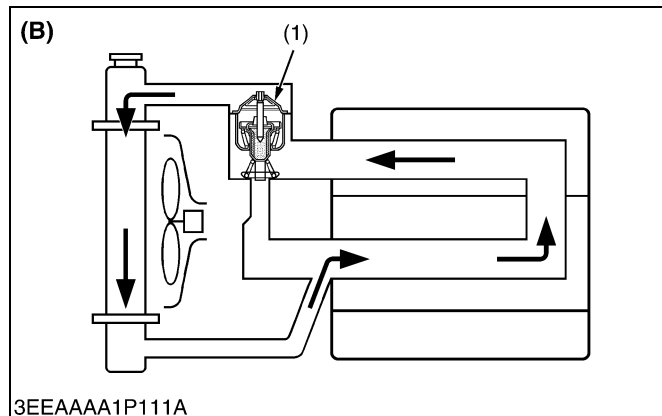
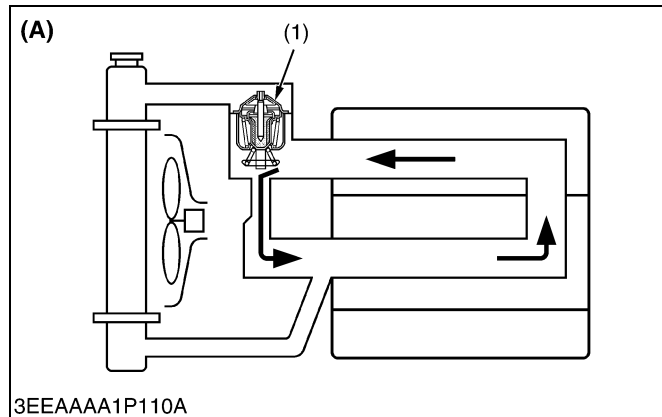

Bottom bypass system is introduced in V3 series for improving the cooling performance of the radiator.

While the temperature of coolant in the engine is low, the thermostat is held closed and the coolant is allowed to flow through the bypass pipe and to circulate in the engine.

When the temperature exceeds the thermostat valve opening level, the thermostat fully opens itself to prevent the hot coolant from flowing through the bypass into the engine.

In this way, the radiator can increase its cooling performance.

(1) Thermostat

(A) Bypass Opened

(B) Bypass Closed

W1013406

## 5. FUEL SYSTEM

### [1] GOVERNOR

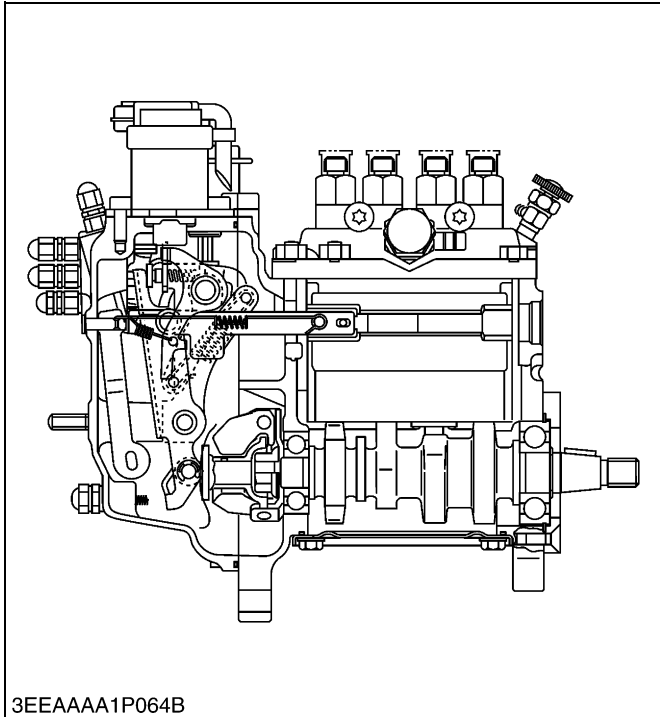

The engine employs the separated fuel injection pump in combination with Kubota's own small multi-function mechanical governor, which enable more dependability.

It also employs the torque limiting mechanism to control the maximum peak torque so that it complies with the regulations of exhaust gas.

This mechanism maintains engine speed at a constant level even under fluctuating loads, provides stable idling and regulates maximum engine speed by controlling the fuel injection rate.

This engine uses a mechanical governor that controls the fuel injection rate at all speed ranges (from idling to maximum speed) by utilizing the balance between the flyweight's centrifugal force and spring tension.

A governor shaft for monitoring engine speed is independent of the injection pump shaft and rotates at twice the speed of conventional types, providing better response to load fluctuation and delivering greater engine output.

W1013830

#### ■ At Start

The stop solenoid (energized-to-run type) is powered to release the stop lever.

As no centrifugal force is applied to flyweight (2), low tension of start spring (1) permits control rack to move the starting position, supplying the amount of fuel required to start the engine.

(1) Start Spring

(2) Flyweight

W1013967

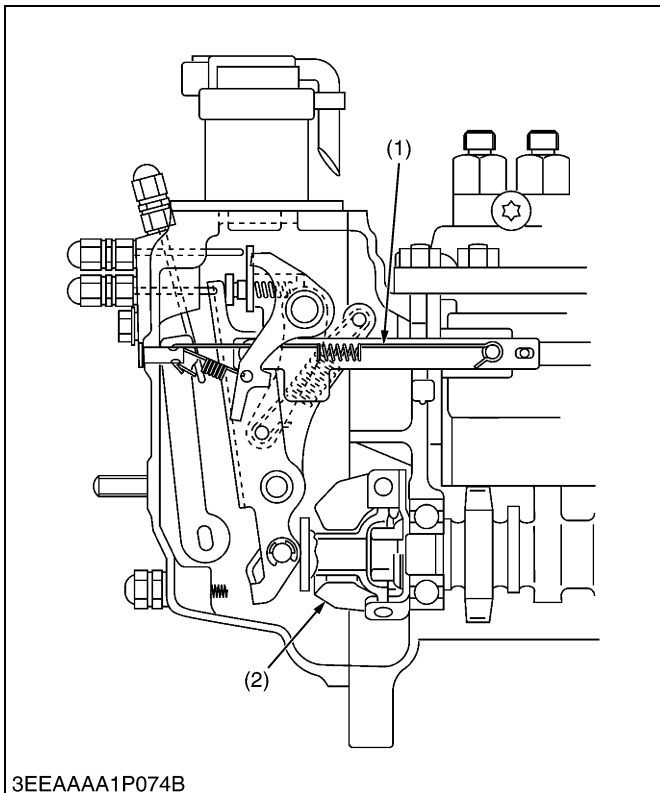

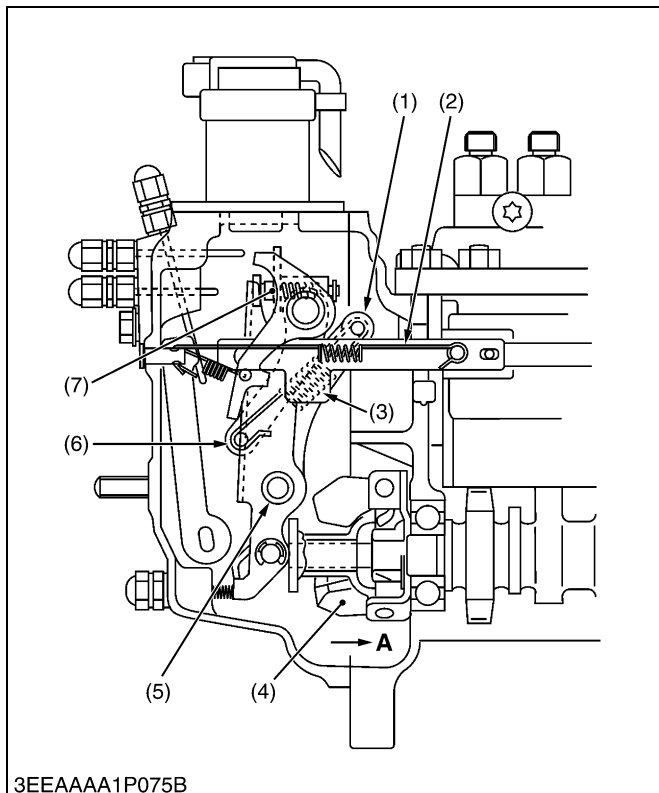

### ■ At Idling

Turn the speed control lever (6) clockwise to idle the engine. It tensions the governor spring (3) to pull the fork lever 2 (1).

When the fork lever 2 is pulled, it moves the torque spring pin (7) and the fork lever 1 (5) in the direction of the arrow **A** to restrain the weight. In combination with the start spring tension, it is balanced with the centrifugal force of flywheel weight to keep idling.

- |                     |                         |
|---------------------|-------------------------|
| (1) Fork Lever 2    | (5) Fork Lever 1        |
| (2) Start Spring    | (6) Speed Control Lever |
| (3) Governor Spring | (7) Spring Pin          |
| (4) Flyweight       |                         |

W1014034

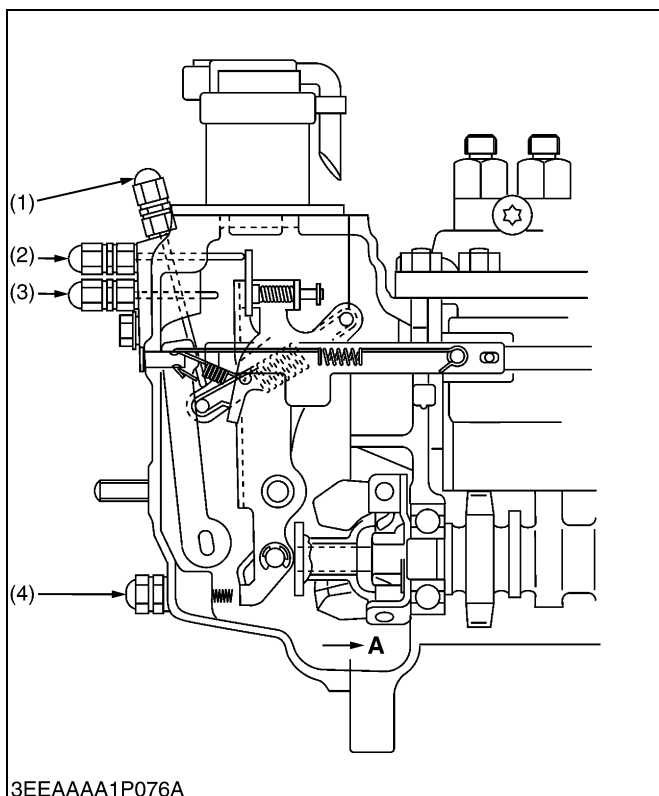

### ■ At rated speed with full load and overload

As the speed control lever is changed from the middle speed to high speed, the governor spring tension increases to compress the torque spring and move the fork lever 1 in the direction of the arrow **A**.

The fork lever 2 moves until it reaches the output limiting bolt to keep rated rotation and rated output.

When the engine is overloaded, the engine rotating speed decreases and the centrifugal force of flywheel weight decreases. Then the torque spring moves the fork lever 1 in the direction of arrow **A**.

The control rack moves in the direction that increases fuel supply to increase the output. It is balanced with the centrifugal force of the flywheel weight to produce low-speed output (torque output).

- |                              |                           |
|------------------------------|---------------------------|
| (1) No-load Maximum Rotation | (3) Torque Limiting Bolt  |
| (2) Output Limiting Bolt     | (4) Idling Adjusting Bolt |

W1014276

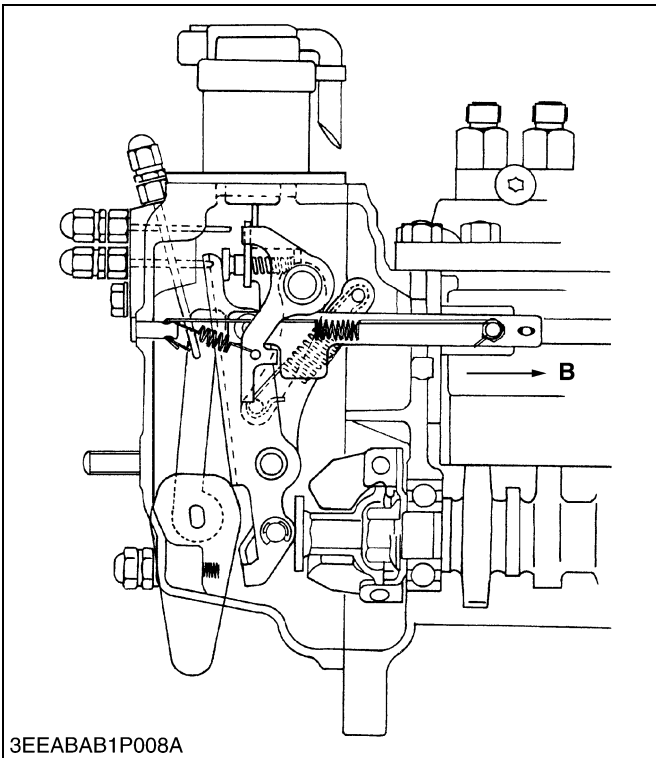

### ■ To stop engine

When the stop solenoid is turned off, the spring tension of the solenoid is released, the rod extrudes and the stop lever moves the control rack in the direction of the arrow **B** which stops the engine.

To stop the engine manually, move the external stop lever to the left.

W1014393

## 6. TURBOCHARGER SYSTEM

### [1] BOOST COMPENSATOR

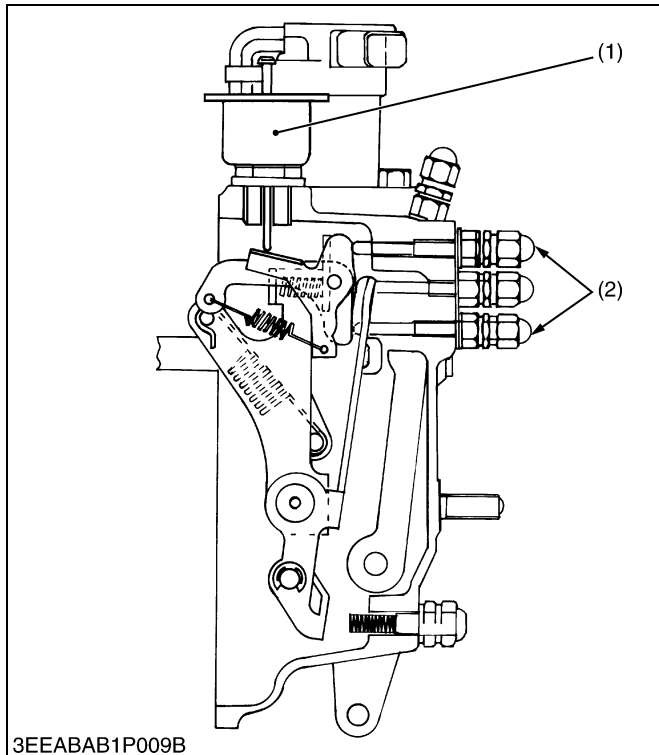

The boost compensator is controlled by the boost pressure of the control mechanism which controls transient smoke caused by oversupply of fuel when the engine starts and accelerates.

When the boost pressure is lower than working pressure of the boost actuator (1), it prevents oversupply of fuel to reduce transient smoke.

When the boost pressure is higher than working pressure of the boost actuator (1), it controls the supply of fuel to the equivalent of maximum power / rated speed output.

The boost compensator adjusting screws (2) are set and tamper-proof capped in factory, so never take off the tamper-proof cap and readjust the screws.

(1) Boost Actuator

(2) Boost Compensator Adjusting Screw

W1014569

# SERVICING

## CONTENTS

1. TROUBLESHOOTING .....	S-1
2. SERVICING SPECIFICATIONS .....	S-5
3. TIGHTENING TORQUES .....	S-12
[1] TIGHTENING TORQUES FOR GENERAL USE SCREWS, BOLTS AND NUTS.....	S-12
[2] TIGHTENING TORQUES FOR SPECIAL USE SCREWS, BOLTS AND NUTS.....	S-13
4. CHECKING, DISASSEMBLING AND SERVICING.....	S-15
[1] CHECKING AND ADJUSTING .....	S-15
(1) Engine Body.....	S-15
(2) Lubricating System .....	S-17
(3) Cooling System.....	S-17
(4) Fuel System .....	S-20
(5) Electrical System .....	S-23
(6) Turbocharger .....	S-27
[2] DISASSEMBLING AND ASSEMBLING.....	S-28
(1) Draining Oil and Coolant.....	S-28
(2) External Components .....	S-28
(3) Cylinder Head and Valves .....	S-30
(4) Thermostat.....	S-34
(5) Injection Nozzle.....	S-34
(6) Injection Pump Unit.....	S-35
(7) Water Pump and Oil Cooler .....	S-45
(8) Gear Case and Timing Gears .....	S-46
(9) Piston and Connecting Rod .....	S-48
(10)Flywheel and Crankshaft .....	S-51
(11)Starter .....	S-54
(12)Alternator .....	S-54
[3] SERVICING .....	S-56
(1) Cylinder Head .....	S-56
(2) Timing Gears .....	S-63
(3) Piston and Connecting Rod .....	S-66
(4) Crankshaft.....	S-68
(5) Cylinder.....	S-72
(6) Oil Pump .....	S-72
(7) Starter .....	S-73
(8) Alternator .....	S-75

# 1. TROUBLESHOOTING

Symptom	Probable Cause	Solution	Reference Page
<b>Engine Does Not Start</b>	No fuel	Replenish fuel	G-9
	Air in the fuel system	Vent air	G-9
	Water in the fuel system	Change fuel and repair or replace fuel system	–
	Fuel hose clogged	Clean or replace	G-9, 26
	Fuel filter clogged	Replace	G-11, 12
	Excessively high viscosity of fuel or engine oil at low temperature	Use specified fuel or engine oil	4, G-11
	Fuel with low cetane number	Use specified fuel	4
	Fuel leak due to loose injection pipe retaining nut	Tighten retaining nut	S-30
	Incorrect injection timing	Adjust	S-20
	Fuel camshaft worn	Replace	S-40
	Injection nozzle clogged	Clean or replace	S-22, 23, 30
	Injection pump malfunctioning	Repair or replace	S-21, 42
	Seizure of crankshaft, camshaft, piston, cylinder or bearing	Repair or replace	–
	Compression leak from cylinder	Replace head gasket, tighten cylinder head screw, glow plug and nozzle holder	S-30, 31, 32, 33
	Improper valve timing	Correct or replace timing gear	S-46
	Piston ring and cylinder worn	Replace	S-49, 50, 67, 72
	Excessive valve clearance	Adjust	S-16
Stop solenoid malfunctioning	Replace	S-27	
<b>Starter Does Not Run</b>	Battery discharged	Charge	G-16, 17
	Starter malfunctioning	Repair or replace	S-25, 54, 73
	Key switch malfunctioning	Replace	–
	Wiring disconnected	Connect	–

W1014322



Symptom	Probable Cause	Solution	Reference Page
<b>Engine Revolution Is Not Smooth</b>	Fuel filter clogged or dirty	Replace	G-11, 12
	Air cleaner clogged	Clean or replace	G-10, 23
	Fuel leak due to loose injection pipe retaining nut	Tighten retaining nut	S-30
	Injection pump malfunctioning	Repair or replace	S-21, 42
	Incorrect nozzle opening pressure	Adjust	S-22, 23, 30
	Injection nozzle stuck or clogged	Repair or replace	S-22, 23, 30
	Governor malfunctioning	Repair	S-37, 38
	Turbocharger bearing worn out	Replace the turbocharger assembly	S-27, 29
	Turbocharger shaft bent	Replace the turbocharger assembly	S-27, 29
	Turbocharger fin or other part damaged due to foreign matters	Replace the turbocharger assembly	S-27, 29
<b>Either White or Blue Exhaust Gas Is Observed</b>	Excessive engine oil	Reduce to specified level	G-6, 8
	Piston ring and cylinder worn or stuck	Repair or replace	S-49, 50, 67, 72
	Incorrect injection timing	Adjust	S-20
<b>Oil Leak into Exhaust Pipe or Suction Pipe</b>	Waste oil pipe clogged or deformed	Repair or replace	S-29
	Turbocharger's piston ring seal faulty	Replace the turbocharger assembly	S-29
<b>Either Black or Dark Gray Exhaust Gas Is Observed</b>	Overload	Reduce the load	–
	Low grade fuel used	Use specified fuel	4
	Fuel filter clogged	Replace	G-11, 12
	Air cleaner clogged	Clean or replace	G-10, 23
	Deficient nozzle injection	Repair or replace nozzle	S-22, 23, 30

W1014322

Symptom	Probable Cause	Solution	Reference Page
<b>Deficient Output</b>	Incorrect injection timing	Adjust	S-20
	Engine's moving parts seem to be seizing	Repair or replace	–
	Injection pump malfunctioning	Repair or replace	S-21, 42
	Deficient nozzle injection	Repair or replace nozzle	S-22, 23, 30
	Compression leak	Check the compression pressure and repair	S-15, 30, 31, 32, 33
	Gas leak from exhaust system	Repair or replace	S-27, 29
	Air leak from compressor discharge side	Repair or replace	S-27, 29
	Air cleaner dirty or clogged	Clean or replace	G-10, 23
	Compressor wheel turning heavily	Replace the turbocharger assembly	S-27, 29
<b>Excessive Lubricant Oil Consumption</b>	Piston ring's gap facing the same direction	Shift ring gap direction	S-49, 50
	Oil ring worn or stuck	Replace	S-49, 50, 67
	Piston ring groove worn	Replace piston	S-49, 50, 68
	Valve stem and valve guide worn	Replace	S-33, 59
	Crankshaft bearing and crank pin bearing worn	Replace	S-50, 53, 69, 71
	Oil leaking due to defective seals or packing	Replace	–
<b>Fuel Mixed into Lubricant Oil</b>	Injection pump's plunger worn	Repair or replace	S-21, 42
	Deficient nozzle injection	Repair or replace nozzle	S-22, 23, 30
	Injection pump broken	Replace	S-21, 42
<b>Water Mixed into Lubricant Oil</b>	Head gasket defective	Replace	S-32, 33
	Cylinder block or cylinder head flawed	Replace	S-57
<b>Low Oil Pressure</b>	Engine oil insufficient	Replenish	G-6, 8
	Oil strainer clogged	Clean	S-48
	Relief valve stuck with dirt	Clean	S-46
	Relief valve spring weaken or broken	Replace	S-46
	Excessive oil clearance of crankshaft bearing	Replace	S-53, 71
	Excessive oil clearance of crankpin bearing	Replace	S-50, 69
	Excessive oil clearance of rocker arm	Replace	S-31, 61
	Oil passage clogged	Clean	–
	Different type of oil	Use specified type of oil	4, G-11
Oil pump defective	Replace	S-17, 72	

W1014322

Symptom	Probable Cause	Solution	Reference Page
<b>High Oil Pressure</b>	Different type of oil	Use specified type of oil	4, G-11
	Relief valve defective	Replace	S-46
<b>Engine Overheated</b>	Engine oil insufficient	Replenish	G-6, 8
	Fan belt broken or elongated	Replace or adjust	G-10, 13
	Coolant insufficient	Replenish	G-7, 14
	Radiator net and radiator fin clogged with dust	Clean	–
	Inside of radiator corroded	Clean or replace	G-13
	Coolant flow route corroded	Clean or replace	G-13
	Radiator cap defective	Replace	S-18
	Overload running	Reduce the load	–
	Head gasket defective	Replace	S-32, 33
	Incorrect injection timing	Adjust	S-20
	Unsuitable fuel used	Use specified fuel	4
<b>Battery Quickly Discharged</b>	Battery electrolyte insufficient	Replenish distilled water and charge	G-16, 17
	Fan belt slips	Adjust belt tension or replace	G-10, 13
	Wiring disconnected	Connect	–
	Rectifier defective	Replace	S-26, 54
	Alternator defective	Replace	S-26, 54
	Battery defective	Replace	S-23, 24, G-26

W1014322

## 2. SERVICING SPECIFICATIONS

### ENGINE BODY

Item		Factory Specification	Allowable Limit
Cylinder Head Surface	Flatness	–	0.05 mm 0.0020 in.
Top Clearance	V3300-E2B	0.72 to 0.90 mm 0.0283 to 0.0354 in.	–
	V3300-T-E2B	0.92 to 1.10 mm 0.0362 to 0.0433 in.	–
Compression Pressure	V3300-E2B	4.32 MPa / 250 min <sup>-1</sup> (rpm) 44 kgf/cm <sup>2</sup> / 250 min <sup>-1</sup> (rpm) 626 psi / 250 min <sup>-1</sup> (rpm)	3.26 MPa / 250 min <sup>-1</sup> (rpm) 33.2 kgf/cm <sup>2</sup> / 250 min <sup>-1</sup> (rpm) 472 psi / 250 min <sup>-1</sup> (rpm)
	V3300-T-E2B	3.92 MPa / 250 min <sup>-1</sup> (rpm) 40 kgf/cm <sup>2</sup> / 250 min <sup>-1</sup> (rpm) 569 psi / 250 min <sup>-1</sup> (rpm)	2.99 MPa / 250 min <sup>-1</sup> (rpm) 30.5 kgf/cm <sup>2</sup> / 250 min <sup>-1</sup> (rpm) 434 psi / 250 min <sup>-1</sup> (rpm)
Variance Among Cylinders		–	10 % or less
Valve Seat	Angle (Intake)	1.047 rad 60 °	–
	Angle (Exhaust)	0.785 rad 45 °	–
	Width	2.12 mm 0.0835 in.	
Valve Face	Angle (Intake)	1.047 rad 60 °	–
	Angle (Exhaust)	0.785 rad 45 °	–
Valve Recessing	Intake	–0.2 to 0 mm –0.079 to 0 in.	–0.4 mm –0.0157 in.
	Exhaust	–0.05 to 0.15 mm –0.0019 to 0.0059 in.	–0.4 mm –0.0157 in.

W10138740

**ENGINE BODY (Continued)**

Item		Factory Specification	Allowable Limit
Valve Stem to Valve Guide	Clearance (Intake)	0.055 to 0.085 mm 0.0022 to 0.0033 in.	0.1 mm 0.0039 in.
Valve Stem	O.D. (Intake)	6.960 to 6.975 mm 0.2740 to 0.2746 in.	—
Valve Guide	I.D. (Intake)	7.030 to 7.045 mm 0.2768 to 0.2774 in.	—
Valve Stem to Valve Guide	Clearance (Exhaust)	0.040 to 0.070 mm 0.0016 to 0.0028 in.	0.1 mm 0.0039 in.
Valve Stem	O.D. (Exhaust)	7.960 to 7.975 mm 0.3134 to 0.3140 in.	—
Valve Guide	I.D. (Exhaust)	8.015 to 8.030 mm 0.3155 to 0.3161 in.	—
Valve Clearance (Cold)		0.23 to 0.27 mm 0.0091 to 0.0106 in.	—
Intake Valve Timing	Open	0.24 rad (14 °) before T.D.C.	—
	Close	0.61 rad (36 °) after B.D.C.	—
Exhaust Valve Timing	Open	0.79 rad (45 °) before B.D.C.	—
	Close	0.29 rad (17 °) after T.D.C.	—
Valve Spring	Free Length (Intake)	35.1 to 35.6 mm 1.3819 to 1.4016 in.	34.6 mm 1.3622 in.
	Free Length (Exhaust)	41.7 to 42.2 mm 1.6417 to 1.6614 in.	41.2 mm 1.6220 in.
	Tilt	—	1.0 mm 0.039 in.
Valve Spring	Setting Load / Setting Length (Intake)	63.547 N / 31.5 mm 6.48 kgf / 31.5 mm 14.256 lbs / 1.2401 in.	45.864 N / 31.5 mm 4.68 kgf / 31.5 mm 10.296 lbs / 1.2401 in.
	Setting Load / Setting Length (Exhaust)	117.6 N / 35 mm 12 kgf / 35 mm 26.4 lbs / 1.3780 in.	100 N / 35 mm 10.2 kgf / 35 mm 22.5 lbs / 1.3780 in.

W1013874

**ENGINE BODY (Continued)**

Item		Factory Specification	Allowable Limit
Rocker Arm Shaft to Rocker Arm	Clearance	0.016 to 0.045 mm 0.0006 to 0.0018 in.	0.15 mm 0.0059 in.
Rocker Arm Shaft	O.D.	15.973 to 15.984 mm 0.6289 to 0.6293 in.	–
Rocker Arm	I.D.	16.000 to 16.018 mm 0.6299 to 0.6306 in.	–
Valve Arm Bridge and Valve Arm Bridge Shaft	Clearance	0.018 to 0.042 mm 0.0007 to 0.0017 in.	0.15 mm 0.0059 in.
Valve Arm Bridge	I.D.	9.050 to 9.065 mm 0.3563 to 0.3569 in.	–
Valve Arm Bridge Shaft	O.D.	9.023 to 9.032 mm 0.3552 to 0.3556 in.	–
Push Rod	Alignment	–	0.25 mm 0.0098 in.
Tappet to Tappet Guide	Clearance	0.020 to 0.062 mm 0.0008 to 0.0024 in.	0.07 mm 0.0028 in.
Tappet Guide Bore	I.D.	24.000 to 24.021 mm 0.9449 to 0.9457 in.	–
Tappet	O.D.	23.959 to 23.980 mm 0.9433 to 0.9441 in.	–
Camshaft	Side Clearance	0.07 to 0.22 mm 0.0028 to 0.0087 in.	0.30 mm 0.0118 in.
	Alignment	–	0.01 mm 0.00039 in.
Cam Height	Intake	37.63 mm 1.4815 in.	37.13 mm 1.4618 in.
	Exhaust	38.96 mm 1.5338 in.	38.46 mm 1.5141 in.
Camshaft	Oil Clearance	0.050 to 0.091 mm 0.0020 to 0.0036 in.	0.15 mm 0.0059 in.
Camshaft Journal	O.D.	45.934 to 45.950 mm 1.8084 to 1.8091 in.	–
Camshaft Bearing	I.D.	46.000 to 46.025 mm 1.8110 to 1.8120 in.	–

W1013874

**ENGINE BODY (Continued)**

Item		Factory Specification	Allowable Limit
Timing Gear			
Idle Gear 1 to Crank Gear	Backlash	0.049 to 0.193 mm 0.0019 to 0.0076 in.	0.22 mm 0.0087 in.
Idle Gear 1 to Cam Gear	Backlash	0.049 to 0.189 mm 0.0019 to 0.0074 in.	0.22 mm 0.0087 in.
Idle Gear 1 to Idle Gear 2	Backlash	0.044 to 0.185 mm 0.0017 to 0.0073 in.	0.22 mm 0.0087 in.
Idle Gear 2 to Injection Pump Gear	Backlash	0.044 to 0.177 mm 0.0017 to 0.0070 in.	0.22 mm 0.0087 in.
Cam Gear to Balancer Gear 1 (Balancer Model Only)	Backlash	0.047 to 0.182 mm 0.0018 to 0.0072 in.	0.22 mm 0.0087 in.
Idle Gear 1 to Balancer Gear 2 (Balancer Model Only)	Backlash	0.044 to 0.183 mm 0.0017 to 0.0072 in.	0.22 mm 0.0087 in.
Idle Gear Shaft 1, 2 to Idle Gear 1, 2 Bushing	Oil Clearance	0.050 to 0.091 mm 0.0020 to 0.0036 in.	0.10 mm 0.0039 in.
Idle Gear 1, 2 Bushing	I.D.	45.025 to 45.050 mm 1.7726 to 1.7736 in.	–
Idle Gear 1, 2 Shaft	O.D.	44.959 to 44.975 mm 1.7700 to 1.7707 in.	–
Idle Gear	Side Clearance	0.15 to 0.30 mm 0.0059 to 0.0118 in.	0.9 mm 0.0354 in.
Balancer Shaft (Balancer Model Only)	Side Clearance	0.070 to 0.22 mm 0.0028 to 0.0087 in.	0.3 mm 0.0118 in.
Balancer Shaft (Balancer Model Only)	Alignment	–	0.02 mm 0.0008 in.
Balancer Shaft (Balancer Model Only)	Oil Clearance	0.070 to 0.159 mm 0.0028 to 0.0063 in.	0.2 mm 0.0079 in.
Balancer Shaft Journal	O.D.	50.92 to 50.94 mm 2.0047 to 2.0055 in.	–
Balancer Bearing	I.D.	51.01 to 51.08 mm 2.0083 to 2.0110 in.	–
Piston Pin Bore	I.D.	30.000 to 30.013 mm 1.1811 to 1.1816 in.	30.05 mm 1.1831 in.
Second Ring to Ring Groove	Clearance	0.093 to 0.120 mm 0.0037 to 0.0047 in.	0.20 mm 0.0079 in.
Oil Ring to Ring Groove	Clearance	0.020 to 0.060 mm 0.0008 to 0.0023 in.	0.15 mm 0.0059 in.

W1013874

**ENGINE BODY (Continued)**

Item		Factory Specification	Allowable Limit
Piston Ring Gap	Top Ring	0.30 to 0.45 mm 0.0118 to 0.0177 in.	1.25 mm 0.0492 in.
	Second Ring	0.30 to 0.45 mm 0.0118 to 0.0177 in.	1.25 mm 0.0492 in.
	Oil Ring	0.25 to 0.45 mm 0.0098 to 0.0177 in.	1.25 mm 0.0492 in.
Connecting Rod	Alignment	–	0.05 mm 0.0020 in.
Piston Pin to Small End Bushing	Clearance	0.020 to 0.040 mm 0.0008 to 0.0016 in.	0.15 mm 0.0059 in.
Piston Pin	O.D.	30.006 to 30.011 mm 1.1813 to 1.1815 in.	–
Small End Bushing	I.D.	30.031 to 30.046 mm 1.1823 to 1.1829 in.	–
Crankshaft	Side Clearance	0.15 to 0.31 mm 0.0059 to 0.0122 in.	0.50 mm 0.0197 in.
	Alignment	–	0.02 mm 0.00079 in.
Crankshaft Journal to Crankshaft Bearing	Oil Clearance	0.018 to 0.062 mm 0.0007 to 0.0024 in.	0.20 mm 0.0079 in.
Crankshaft Journal	O.D.	74.977 to 74.990 mm 2.9518 to 2.9524 in.	–
Crank Pin to Pin Bearing	Oil Clearance	0.018 to 0.051 mm 0.0007 to 0.0020 in.	0.20 mm 0.0079 in.
Crank Pin	O.D.	52.977 to 52.990 mm 2.0857 to 2.0862 in.	–
Cylinder Bore	I.D.	98.000 to 98.022 mm 3.8582 to 3.8591 in.	98.15 mm 3.8642 in.
Cylinder Bore (Oversize)	I.D.	98.500 to 98.522 mm 3.8780 to 3.8788 in.	98.65 mm 3.8839 in.

W10138740



**LUBRICATING SYSTEM**

Item		Factory Specification	Allowable Limit
Engine Oil Pressure	At Idle Speed	–	49 kPa 0.5 kgf/cm <sup>2</sup> 7 psi
	At Rated Speed	196 to 392 kPa 2.0 to 4.0 kgf/cm <sup>2</sup> 28 to 57 psi	147.1 kPa 1.5 kgf/cm <sup>2</sup> 21.3 psi
Engine Oil Pressure Switch	Working Pressure	39.2 to 58.8 kPa 0.4 to 0.6 kgf/cm <sup>2</sup> 5.6 to 8.4 psi	–
Inner Rotor to Outer Rotor	Clearance	0.04 to 0.16 mm 0.0016 to 0.0063 in.	0.3 mm 0.0118 in.
Outer Rotor to Pump Body	Clearance	0.100 to 0.184 mm 0.0039 to 0.0072 in.	0.3 mm 0.0118 in.
Inner Rotor to Cover	Clearance	0.025 to 0.075 mm 0.0010 to 0.0030 in.	0.225 mm 0.0089 in.
Relief Valve	Working Pressure	885 kPa 9.04 kgf/cm <sup>2</sup> 129 psi	–

W10139730

**COOLING SYSTEM**

Thermostat	Valve Opening Temperature	74.5 to 78.5 °C 166.1 to 173.3 °F	–
	Valve Opening Temperature (Opened Completely)	90 °C 194 °F	–
Radiator	Water Tightness	Water tightness at specified pressure 137 kPa 1.4 kgf/cm <sup>2</sup> 20 psi	–
Radiator Cap	Air Leakage	10 seconds or more 88 → 59 kPa 0.9 → 0.6 kgf/cm <sup>2</sup> 13 → 9 psi	–
Fan Belt	Tension	10.0 to 12.0 mm / 98 N 0.394 to 0.472 in. / 98 N (10 kgf, 22 lbs)	–

W10135990

**FUEL SYSTEM**

Item		Factory Specification	Allowable Limit
Injection Timing	V3300-E2B	0.19 to 0.23 rad (11 to 13 °) before T.D.C.	–
	V3300-T-E2B	0.11 to 0.14 rad (6 to 8 °) before T.D.C.	–
Pump Element	Fuel Tightness	–	13.73 MPa 140 kgf/cm <sup>2</sup> 1991 psi
Delivery Valve	Fuel Tightness	10 seconds 13.73 → 12.75 MPa 140 → 130 kgf/cm <sup>2</sup> 1991 → 1849 psi	5 seconds 13.73 → 12.75 MPa 140 → 130 kgf/cm <sup>2</sup> 1991 → 1849 psi
Fuel Injection Nozzle	Injection Pressure	13.73 to 14.71 MPa 140 to 150 kgf/cm <sup>2</sup> 1991 to 2134 psi	–
	Valve Seat Tightness	When the pressure is 12.75 MPa (130 kgf/cm <sup>2</sup> , 1849 psi), the valve seat must be fuel tightness.	–

W10139730

**ELECTRICAL SYSTEM**

Commutator	O.D.	32 mm 1.2598 in.	31.4 mm 1.2362 in.
Mica	Undercut	0.5 mm 0.0197 in.	0.2 mm 0.0079 in.
Brush (Starter)	Length	18.0 mm 0.7086 in.	11.0 mm 0.4331 in.
Alternator	No-load Voltage	14 V at 4000 min <sup>-1</sup> (rpm)	–
Rotor Coil	Resistance	2.8 to 3.3 Ω	–
Slip Ring	O.D.	22.7 mm 0.894 in.	22.1 mm 0.870 in.
Brush (Alternator)	Length	18.5 mm 0.728 in.	5.0 mm 0.197 in.
Glow Plug	Resistance (at cold occasion)	Approx. 1.0 Ω	–

W1013973

### 3. TIGHTENING TORQUES

Screws, bolts and nuts must be tightened to the specified torque using a torque wrench, several screws, bolts and nuts such as those used on the cylinder head must be tightened in proper sequence and the proper torque.

#### [1] TIGHTENING TORQUES FOR GENERAL USE SCREWS, BOLTS AND NUTS

When the tightening torques are not specified, tighten the screws, bolts and nuts according to the table below.

Grade Nominal Diameter	Unit	Standard Screw and Bolt ④			Special Screw and Bolt ⑦		
		N-m	kgf-m	ft-lbs	N-m	kgf-m	ft-lbs
M6		7.9 to 9.3	0.80 to 0.95	5.8 to 6.9	9.8 to 11.3	1.00 to 1.15	7.23 to 8.32
M8		17.7 to 20.6	1.8 to 2.1	13.0 to 15.2	23.5 to 27.5	2.4 to 2.8	17.4 to 20.3
M10		39.2 to 45.1	4.0 to 4.6	28.9 to 33.3	48.1 to 55.9	4.9 to 5.7	35.4 to 41.2
M12		62.8 to 72.6	6.4 to 7.4	46.3 to 53.5	77.5 to 90.2	7.9 to 9.2	57.1 to 66.5

W10371750

Screw and bolt material grades are shown by numbers punched on the screw and bolt heads. Prior to tightening, be sure to check out the numbers as shown below.

Punched number	Screw and bolt material grade
None or 4	Standard screw and bolt SS41, S20C
7	Special screw and bolt S43C, S48C (Refined)

W1012705

## [2] TIGHTENING TORQUES FOR SPECIAL USE SCREWS, BOLTS AND NUTS

### ■ NOTE

- For “\*” marked screws, bolts and nuts on the table, apply engine oil to their threads and seats before tightening.
- The letter “M” in Size x Pitch means that the screw, bolt or nut dimension stands for metric. The size is the nominal outside diameter in mm of the threads. The pitch is the nominal distance in mm between two threads.

Item	Size x Pitch	N·m	kgf·m	ft·lbs
Cylinder head cover screw	–	6.9 to 11.3	0.7 to 1.15	5.1 to 8.32
*Cylinder head screw	M12 x 1.25	98.1 to 107.9	10.0 to 11.0	72.3 to 79.6
*Connecting rod screw	M10 x 1.25	78.5 to 83.4	8.0 to 8.5	57.9 to 61.5
*Flywheel screw	M12 x 1.25	98.1 to 107.9	10.0 to 11.0	72.3 to 79.6
*Crankshaft screw	M16 x 1.5	255.0 to 274.6	26.0 to 28.0	188.1 to 202.5
*Main bearing case screw	M14 x 1.5	137.3 to 147.1	14.0 to 15.0	101.3 to 108.5
Rocker arm bracket screw	M10 x 1.25	49.0 to 55.9	5.0 to 5.7	36.2 to 41.2
Nozzle holder assembly	M20 x 1.5	49.0 to 68.6	5.0 to 7.0	36.2 to 50.6
Nozzle holder	–	34.3 to 39.2	3.5 to 4.0	25.3 to 28.9
Injection pipe retaining nut	M12 x 1.5	22.6 to 36.3	2.3 to 3.7	16.6 to 26.8
Overflow pipe assembly retaining nut	M12 x 1.5	19.6 to 24.5	2.0 to 2.5	14.5 to 18.1
Oil switch taper screw	R 1/8	14.7 to 19.6	1.5 to 2.0	10.8 to 14.5
Oil cooler joint screw	–	39.2 to 44.1	4.0 to 4.5	28.9 to 32.5
Oil pump cover screw	–	7.9 to 9.3	0.80 to 0.95	5.8 to 6.9
Glow plugs	M10 x 1.25	19.6 to 24.5	2.0 to 2.5	14.5 to 18.1
Starter's terminal <b>B</b> mounting nut	M8 x 1.25	9.8 to 11.8	1.0 to 1.2	7.2 to 8.7
Injection pump gear mounting nut	M14 x 1.5	73.6 to 83.4	7.5 to 8.5	54.2 to 61.5
Injection pump unit mounting nut	M8 x 1.25	17.7 to 20.6	1.8 to 2.1	13.0 to 15.2
Gear case cover	M8 x 1.25	23.5 to 27.5	2.4 to 2.8	17.4 to 20.3
Relief valve retaining screw	–	68.6 to 78.4	7.0 to 8.0	50.6 to 57.9
Idle gear mounting screw	M8 x 1.25	23.5 to 27.5	2.4 to 2.8	17.4 to 20.3
Plate mounting screw	M8 x 1.25	23.5 to 27.5	2.4 to 2.8	17.4 to 20.3
Camshaft set screw	M8 x 1.25	23.5 to 27.5	2.4 to 2.8	17.4 to 20.3
Flywheel housing mounting screw	M12 x 1.25	77.5 to 90.2	7.9 to 9.2	57.1 to 66.5
Crankcase 2 mounting screw	M10 x 1.25	49.0 to 55.9	5.0 to 5.7	36.2 to 41.2
Injection pump mounting screw	M8 x 1.25	23.5 to 27.5	2.4 to 2.8	17.4 to 20.3
Injection pump mounting nut	M8 x 1.25	17.7 to 20.6	1.8 to 2.1	13.0 to 15.2
Boost actuator (Boost compensator model only)	–	39.2 to 45.1	4.0 to 4.6	28.9 to 33.3
Governor weight mounting nut	M12 x 1.25	62.8 to 72.6	6.4 to 7.4	46.3 to 53.5
Fuel camshaft stopper mounting screw	–	7.9 to 9.3	0.80 to 0.95	5.8 to 6.9

W1013236

<b>Item</b>	<b>Size x Pitch</b>	<b>N·m</b>	<b>kgf·m</b>	<b>ft-lbs</b>
Governor housing mounting screw	M6 x 1.0	9.8 to 11.3	1.00 to 1.15	7.23 to 8.32
Anti-rotation nut	M5 x 0.8	2.8 to 4.0	0.29 to 0.41	2.1 to 3.0
Balancer shaft set screw (Balancer model only)	M8 x 1.25	23.5 to 27.5	2.4 to 2.8	17.4 to 20.3
Bearing case cover mounting screw	M8 x 1.25	23.5 to 27.5	2.4 to 2.8	17.4 to 20.3
Alternator pulley nut	–	58.3 to 78.9	5.95 to 8.05	43.0 to 58.2

W1013236

## 4. CHECKING, DISASSEMBLING AND SERVICING

### [1] CHECKING AND ADJUSTING

#### (1) Engine Body

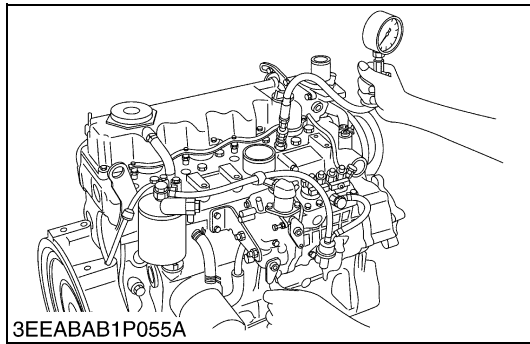

#### Compression Pressure

1. After warming up the engine, stop it and remove the air cleaner, the muffler and all nozzle holders.
2. Install a compression tester (Code No: 07909-30208) for diesel engines to nozzle holder hole.
3. After making sure that the stop lever is set at the stop position (Non-injection), run the engine at 200 to 300 min<sup>-1</sup> (rpm) with the starter.
4. Read the maximum pressure. Measure the pressure more than twice.
5. If the measurement is below the allowable limit, apply a small amount of oil to the cylinder wall through the nozzle hole and measure the compression pressure again.
6. If the compression pressure increase after applying oil. check the cylinder wall and piston rings.
7. If the compression pressure is still less than the allowable limit, check the top clearance, valve and cylinder head.

#### ■ NOTE

- Check the compression pressure with the specified valve clearance.
- Always use a fully charged battery for performing this test.
- Variances in cylinder compression values should be under 10 %.

Compression pressure	Factory spec.	V3300-E2B	4.32 MPa / 250 min <sup>-1</sup> (rpm) 44 kgf/cm <sup>2</sup> / 250 min <sup>-1</sup> (rpm) 626 psi / 250 min <sup>-1</sup> (rpm)
		V3300-T-E2B	3.92 MPa / 250 min <sup>-1</sup> (rpm) 40 kgf/cm <sup>2</sup> / 250 min <sup>-1</sup> (rpm) 569 psi / 250 min <sup>-1</sup> (rpm)
	Allowable limit	V3300-E2B	3.26 MPa / 250 min <sup>-1</sup> (rpm) 33.2 kgf/cm <sup>2</sup> / 250 min <sup>-1</sup> (rpm) 472 psi / 250 min <sup>-1</sup> (rpm)
		V3300-T-E2B	2.99 MPa / 250 min <sup>-1</sup> (rpm) 30.5 kgf/cm <sup>2</sup> / 250 min <sup>-1</sup> (rpm) 434 psi / 250 min <sup>-1</sup> (rpm)

Tightening torque	Nozzle holder assembly	49.0 to 68.6 N·m 5.0 to 7.0 kgf·m 36.2 to 50.6 ft-lbs
	Overflow pipe assembly retaining nut	19.6 to 24.5 N·m 2.0 to 2.5 kgf·m 14.5 to 18.1 ft-lbs
	Injection pipe retaining nut	22.6 to 36.3 N·m 2.3 to 3.7 kgf·m 16.6 to 26.8 ft-lbs

W1048776

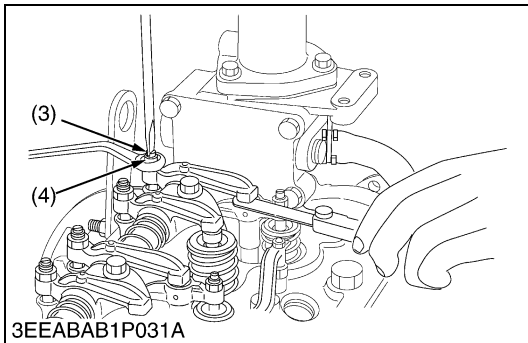
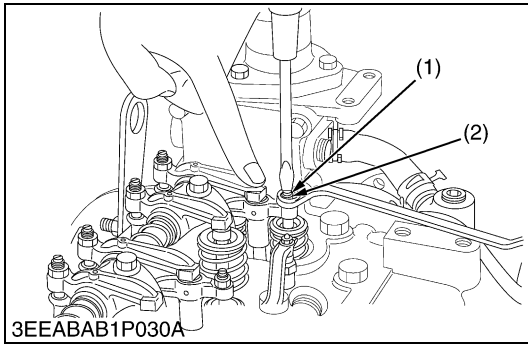
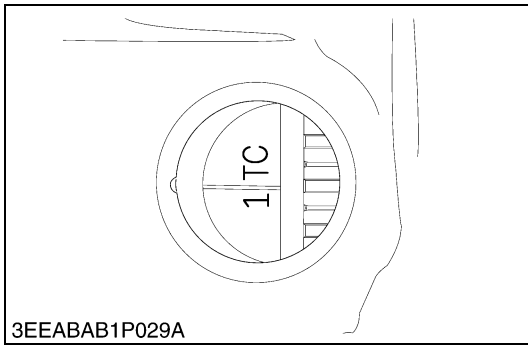

### Checking Valve Clearance

■ **IMPORTANT**

- **Valve clearance must be checked and adjusted when engine is cold.**

1. Remove the head cover.
2. Align the 1TC mark of flywheel and the convex of flywheel housing timing windows so that the first piston (gear case side) comes to the compression top dead center.
3. Before adjusting the valve clearance of intake valve, adjust the bridge evenly to the valves stem.
4. Loosen the lock nut (2) and adjust with screw (1).
5. Slightly push the rocker arm (intake side) by your fingers and screw in the adjusting screw slowly until you feel the screw touch the top of valve stem, then tighten the lock nut.
6. Loosen the lock nut (4) of adjusting screw (3) (push rod side) and insert the thickness gauge between the rocker arm and the bridge head. Set the adjusting screw to the specified value, then tighten the lock nut.
7. Adjust the clearance between the rocker arm (exhaust side) and the exhaust valve to the specified value.

Valve clearance	Factory spec.	0.23 to 0.27 mm 0.0091 to 0.0106 in.
-----------------	---------------	---

■ **NOTE**

- **After adjusting, tighten the lock nut (4) securely.**

Valve arrangement Adjustment cylinder Location of piston		IN.	EX
When No.1 piston is at compression top dead center	1st	☆	☆
	2nd	☆	
	3rd		☆
	4th		
When No.1 piston is at overlap position	1st		
	2nd		☆
	3rd	☆	
	4th	☆	☆

Tightening torque	Cylinder head cover screw	6.9 to 11.3 N-m 0.7 to 1.15 kgf-m 5.1 to 8.32 ft-lbs
-------------------	---------------------------	--

- (1) Adjusting Screw (2) Lock Nut (3) Adjusting Screw (4) Lock Nut

W1020115

## (2) Lubricating System

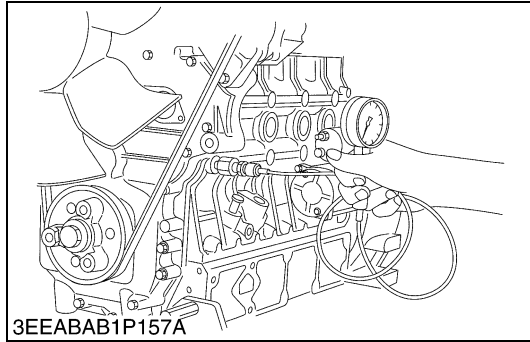

### Engine Oil Pressure

1. Remove the oil switch and set a pressure tester (Code No. 07916-32032).
2. Start the engine. After warming up, measure the oil pressure of both idling and rated speeds.
3. If the oil pressure is less than the allowable limit, check the following.
  - Engine oil insufficient
  - Oil pump defective
  - Oil strainer clogged
  - Oil filter cartridge clogged
  - Oil gallery clogged
  - Excessive oil clearance
  - Foreign matter in the relief valve

### (When reassembling)

- After checking the engine oil pressure, tighten the engine oil pressure switch to the specified torque.

Engine oil pressure	At idle speed	Allowable limit	49 kPa 0.5 kgf/cm <sup>2</sup> 7 psi
	At rated speed	Factory spec.	196 to 392 kPa 2.0 to 4.0 kgf/cm <sup>2</sup> 28 to 57 psi
		Allowable limit	147.1 kPa 1.5 kgf/cm <sup>2</sup> 21.3 psi

Tightening torque	Oil switch taper screw	14.7 to 19.6 N-m 1.5 to 2.0 kgf-m 10.8 to 14.5 ft-lbs
-------------------	------------------------	---

W10349520

## (3) Cooling System

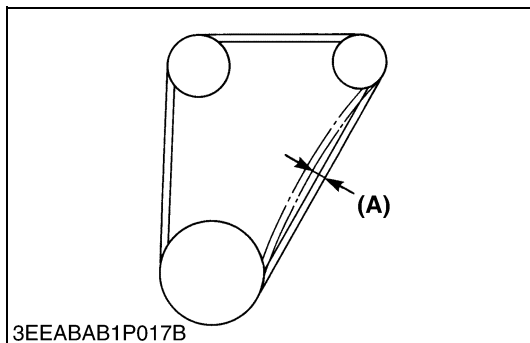

### Fan Belt Tension

1. Measure the deflection **(A)**, depressing the belt halfway between the fan drive pulley and alternator pulley at specified force 98 N (10 kgf, 22 lbs).
2. If the measurement is not within the factory specifications, loosen the alternator mounting screws and relocate the alternator to adjust.

Deflection <b>(A)</b>	Factory spec.	10 to 12 mm 0.394 to 0.472 in.
-----------------------	---------------	-----------------------------------

**(A) Deflection**

W1021011



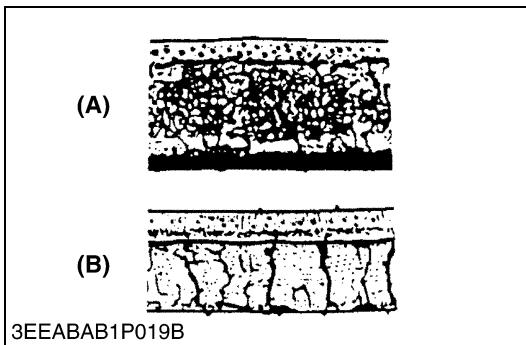

### Fan Belt Damage and Wear

1. Check the fan belt for damage.
2. If the fan belt is damaged, replace it.
3. Check if the fan belt is worn and sunk in the pulley groove.
4. If the fan belt is nearly worn out and deeply sunk in the pulley groove, replace it.

(A) Good

(B) Bad

W1021108

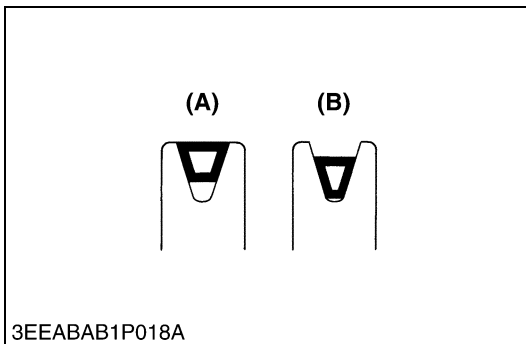

### CAUTION

- When removing the radiator cap, wait at least ten minutes after the engine has stopped and cooled down. Otherwise, hot water may gush out, scalding nearby people.

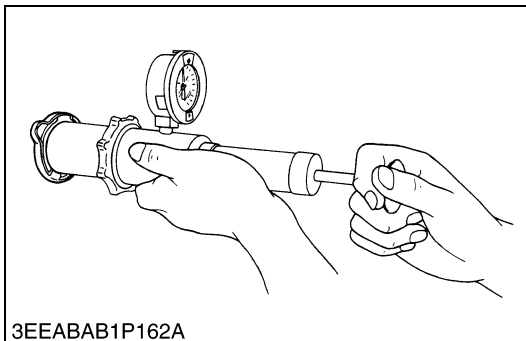

### Radiator Cap Air Leakage

1. Set a radiator tester on the radiator cap.
2. Set a radiator tester.  
Apply the specified pressure of 88 kPa (0.9 kgf/cm<sup>2</sup>, 13 psi).
3. Check if the pressure drop to less than 59 kPa (0.6 kgf/cm<sup>2</sup>, 9 psi) in 10 seconds.
4. If the pressure is less than the factory specification, replace it.

W1021320

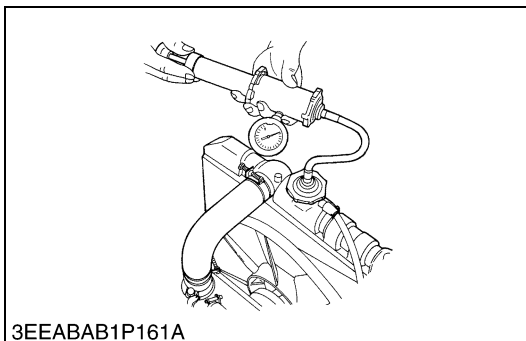

### Radiator Water Leakage

1. Pour a specified amount of water into the radiator.
2. Set a radiator tester.  
Increase water pressure to the specified pressure of 137 kPa (1.4 kgf/cm<sup>2</sup>, 20 psi).
3. Check the radiator for water leaks.
4. When water leakage is excessive, replace the radiator. If water leakage is caused by a small pinhole, correct the radiator with radiator cement.

W1072497

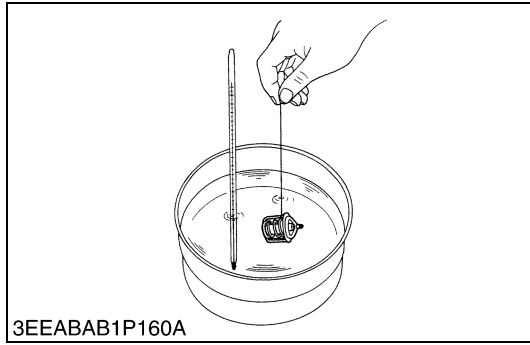

### **Thermostat Valve Opening Temperature**

1. Push down the thermostat valve and insert a string between the valve and the valve seat.
2. Place the thermostat and a thermometer in a container with water and gradually heat the water.
3. Hold the string to suspend the thermostat in the water. When the water temperature rises, the thermostat valve will open, allowing it to fall down from the string.  
Read the temperature at this moment on the thermometer.
4. Continue heating the water and read the temperature when the valve has risen by about 8 mm (0.315 in.).
5. If the measurement is not acceptable, replace the thermostat.

Thermostat's valve opening temperature	Factory spec.	74.5 to 78.5 °C 166.1 to 173.3 °F
Temperature at which thermostat completely opens	Factory spec.	90 °C 194 °F

W1071639

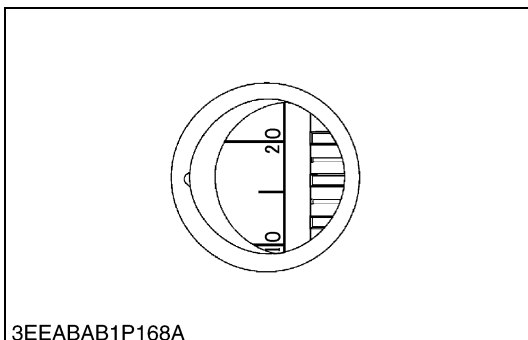
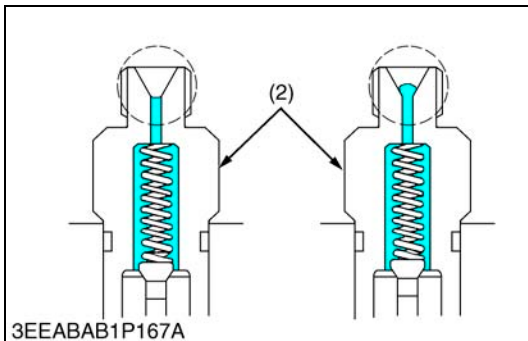
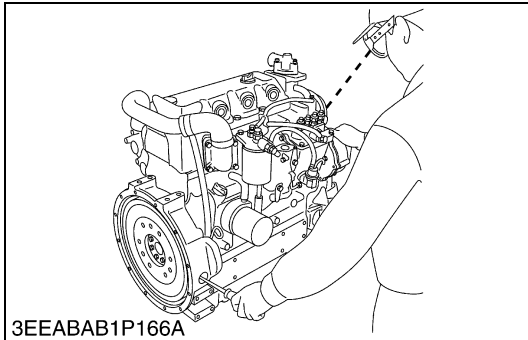
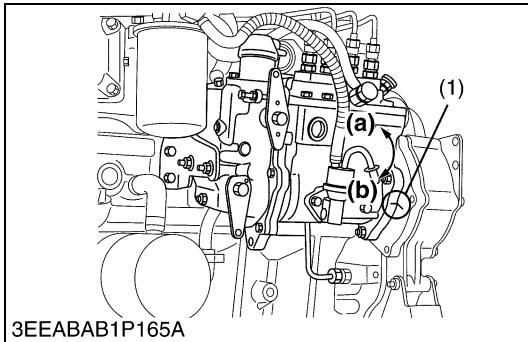
**(4) Fuel System****Injection Timing**

1. Make sure of matching the injection timing align mark (1) of the injection pump unit and the plate (gearcase), as shown in the illustration.
2. Remove the injection pipes.
3. Remove the stop solenoid.
4. Turn the flywheel counterclockwise (viewed from flywheel side) until the fuel fills up to the hole of the delivery valve holder (2) for No.1 cylinder.
5. After the fuel fills up to the hole of the delivery valve holder for No.1 cylinder, turn back (clockwise) the flywheel around 1.57 rad (90 °).
6. Turn the flywheel counterclockwise to set at around 0.35 rad (20 °) before T.D.C..
7. Slowly turn the flywheel counterclockwise and stop turning when the fuel begins to come up, to get the present injection timing.
8. Check to see the degree on flywheel.  
The flywheel has mark "1TC", "10" and "20" for the crank angle before the top dead center of No.1 piston.
9. If the injection timing is not within the specification, rotate the injection pump unit to adjust the injection timing.

**■ IMPORTANT**

- **When installing the injection pump unit to the engine body, follow the correct procedure. See the "Injection Pump Unit".**

Injection timing	Factory spec.	V3300-E2B	0.19 to 0.23 rad (11 ° to 13 °) before T.D.C.
		V3300-T-E2B	0.11 to 0.14 rad (6 ° to 8 °) before T.D.C.

Tightening torque	Injection pipe retaining nut	22.6 to 36.3 N-m 2.3 to 3.7 kgf-m 16.6 to 26.8 ft-lbs
	Injection pump unit mounting nut	17.7 to 20.6 N-m 1.8 to 2.1 kgf-m 13.0 to 15.2 ft-lbs

- (1) Injection Timing Align Mark  
(2) Delivery Valve Holder

- (a) Injection Timing Advanced**  
**(b) Injection Timing Retarded**

W1036105

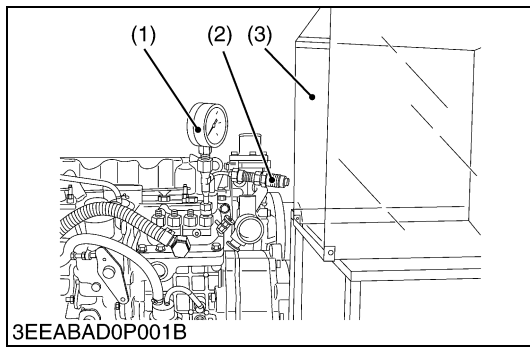

**Fuel Tightness of Pump Element**

1. Remove the engine stop solenoid.
2. Remove the injection pipes.
3. Install the injection pump pressure tester to the injection pump.
4. Install the injection nozzle (2) jetted with the proper injection pressure to the injection pump pressure tester (1). (Refer to the figure.)
5. Set the speed control lever to the maximum speed position.
6. Run the starter to increase the pressure.
7. If the pressure can not reach the allowable limit, replace the pump with new one or repair with a Kubota-authorized pump service shop.

Fuel tightness of pump element	Allowable limit	13.73 MPa 140 kgf/cm <sup>2</sup> 1991 psi
--------------------------------	-----------------	--

**NOTE**

- **Never try to disassemble the injection pump assembly. For repairs, you are strongly requested to contact a Kubota-authorized pump service shop.**

- (1) Injection Pump Pressure Tester      (3) Protection Cover for Jetted Fuel  
 (2) Injection Nozzle

W1017430

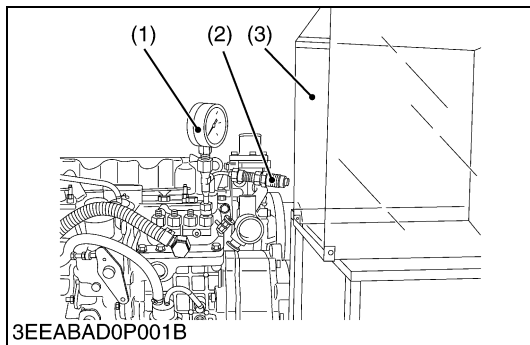

**Fuel Tightness of Delivery Valve**

1. Remove the engine stop solenoid.
2. Remove the injection pipes.
3. Set a pressure tester to the fuel injection pump.
4. Install the injection nozzle (2) jetted with the proper injection pressure to the injection pump pressure tester (1).
5. Run the starter to increase the pressure.
6. Stop the starter when the fuel jets from the injection nozzle. After that, turn the flywheel by the hand and raise the pressure to approx. 13.73 MPa (140 kgf/cm<sup>2</sup>, 1991 psi).
7. Now turn the flywheel back about half a turn (to keep the plunger free). Maintain the flywheel at this position and clock the time taken for the pressure to drop from 13.73 to 12.75 MPa (from 140 to 130 kgf/cm<sup>2</sup>, from 1991 to 1849 psi).
8. Measure the time needed to decrease the pressure from 13.73 to 12.75 MPa (from 140 to 130 kgf/cm<sup>2</sup>, from 1991 to 1849 psi).
9. If the measurement is less than allowable limit, replace the pump with new one or repair with a Kubota-authorized pump service shop.

Fuel tightness of delivery valve	Factory spec.	10 seconds 13.73 → 12.75 MPa 140 → 130 kgf/cm <sup>2</sup> 1991 → 1849 psi
	Allowable limit	5 seconds 13.73 → 12.75 MPa 140 → 130 kgf/cm <sup>2</sup> 1991 → 1849 psi

**NOTE**

- **Never try to disassemble the injection pump assembly. For repairs, you are strongly requested to contact a Kubota-authorized pump service shop.**

- (1) Injection Pump Pressure Tester      (3) Protection Cover for Jetted Fuel  
 (2) Injection Nozzle

W1017786

**CAUTION**

- Check the nozzle injection pressure and condition after confirming that there is nobody standing in the direction the fume goes.
- If the fume from the nozzle directly contacts the human body, cells may be destroyed and blood poisoning may be caused.

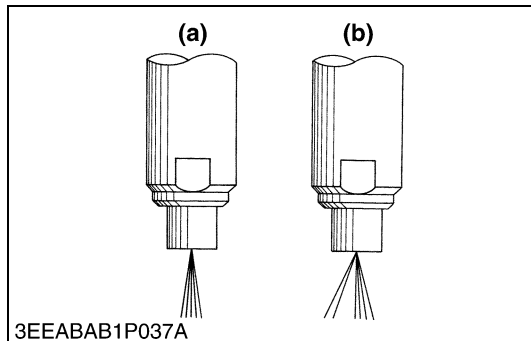

**Nozzle Spraying Condition**

1. Set the injection nozzle to a nozzle tester, and check the nozzle spraying condition.
2. If the spraying condition is defective, replace the nozzle piece.

(a) Good

(b) Bad

W10181310

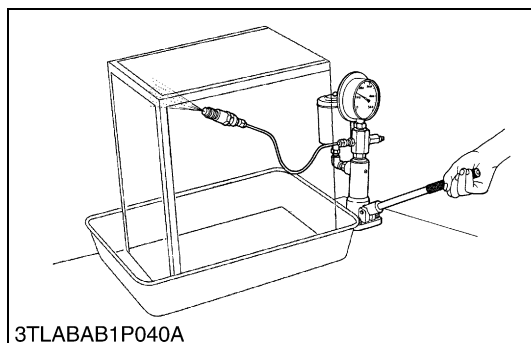

**Fuel Injection Pressure**

1. Set the injection nozzle to a nozzle tester.
2. Slowly move the tester handle to measure the pressure at which fuel begins jetting out from the nozzle.
3. If the measurement is not within the factory specifications, replace the adjusting washer (1) in the nozzle holder to adjust it.

**(Reference)**

- Pressure variation with 0.025 mm (0.0010 in.) difference of adjusting washer thickness.  
Approx. 588 kPa (6.0 kgf/cm<sup>2</sup>, 85 psi)

Fuel injection pressure	Factory spec.	13.73 to 14.71 MPa 140 to 150 kgf/cm <sup>2</sup> 1991 to 2134 psi
-------------------------	---------------	--

(1) Adjusting Washer

W10182100

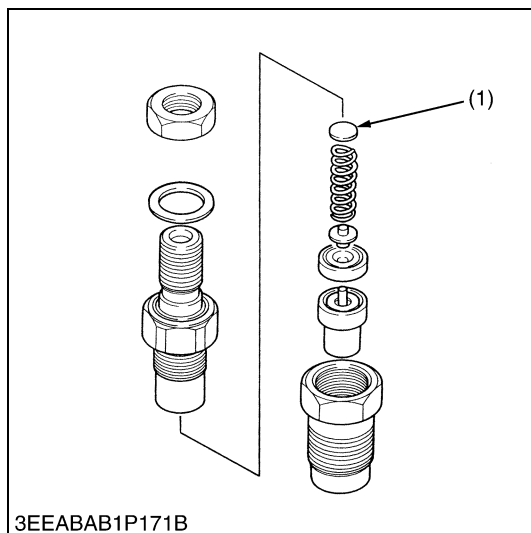

**Valve Seat Tightness**

1. Set the injection nozzle to a nozzle tester.
2. Raise the fuel pressure, and keep at 12.75 MPa (130 kgf/cm<sup>2</sup>, 1849 psi) for 10 seconds.
3. If any fuel leak is found, replace the nozzle piece.

Valve seat tightness	Factory spec.	No fuel leak at 12.75 MPa 130 kgf/cm <sup>2</sup> 1849 psi
----------------------	---------------	---

W10183690

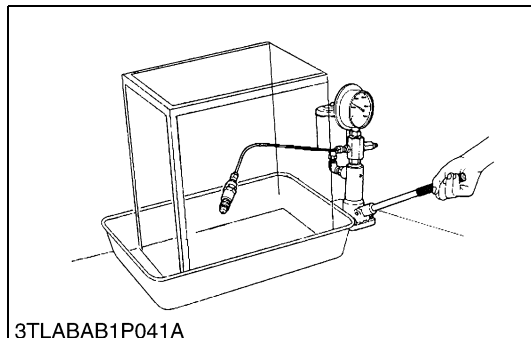

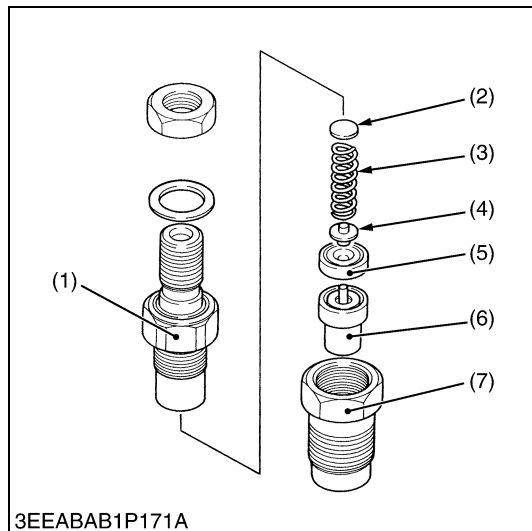

**Nozzle Holder**

1. Secure the nozzle retaining nut (7) with a vise.
2. Remove the nozzle holder (1), and take out parts inside.

**(When reassembling)**

- Assemble the nozzle in clean fuel oil.
- Install the push rod (4), noting its direction.
- After assembling the nozzle, be sure to adjust the fuel injection pressure.

Tightening torque	Nozzle holder	34.3 to 39.2 N·m 3.5 to 4.0 kgf·m 25.3 to 28.9 ft-lbs
	Overflow pipe retaining nut	19.6 to 24.5 N·m 2.0 to 2.5 kgf·m 14.5 to 18.1 ft-lbs
	Nozzle holder assembly	49.0 to 68.6 N·m 5.0 to 7.0 kgf·m 36.2 to 50.6 ft-lbs

- |                      |                          |
|----------------------|--------------------------|
| (1) Nozzle Holder    | (5) Distance Piece       |
| (2) Adjusting Washer | (6) Nozzle Piece         |
| (3) Nozzle Spring    | (7) Nozzle Retaining Nut |
| (4) Push Rod         |                          |

W1018491

**(5) Electrical System**

**CAUTION**

- To avoid accidental short circuit, be sure to attach the positive cable to the positive terminal before the negative cable is attached to the negative terminal.
- Never remove the battery cap while the engine is running.
- Keep electrolyte away from eyes, hands and clothes. If you are splattered with it, wash it away completely with water immediately.
- Keep open sparks and flames away from the battery at all times. Hydrogen gas mixed with oxygen becomes very explosive.

**IMPORTANT**

- If the machine is to be operated for a short time without battery (using a slave battery for starting), use additional current (lights) while engine is running and insulate terminal of battery. If this advice is disregarded, damage to alternator and regulator may result.

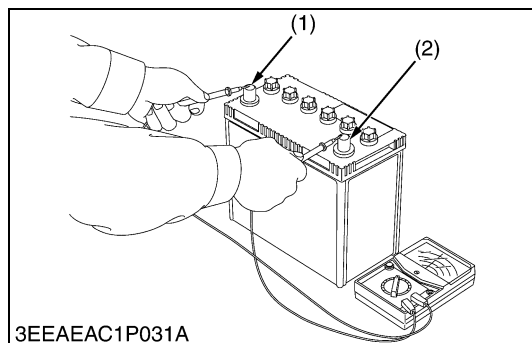

**Battery Voltage**

1. Stop the engine.
2. Measure the voltage with a circuit tester between the battery terminals.
3. If the battery voltage is less than the factory specification, check the battery specific gravity and recharge the battery.

Battery voltage	Factory spec.	More than 12 V
-----------------	---------------	----------------

- |                       |                       |
|-----------------------|-----------------------|
| (1) Positive Terminal | (2) Negative Terminal |
|-----------------------|-----------------------|

W10125620

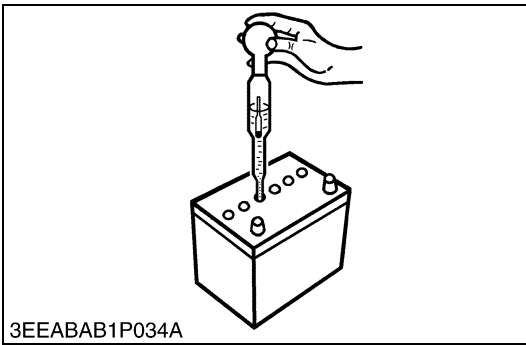

3EEABAB1P034A

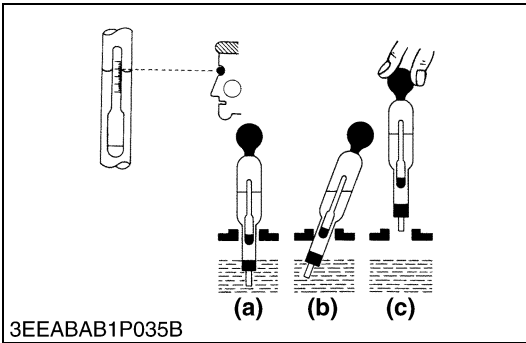

3EEABAB1P035B

### Battery Specific Gravity

1. Check the specific gravity of the electrolyte in each cell with a hydrometer.
2. When the electrolyte temperature differs from that at which the hydrometer was calibrated, correct the specific gravity reading following the formula mentioned in **(Reference)**.
3. If the specific gravity is less than 1.215 (after it is corrected for temperature), charge or replace the battery.
4. If the specific gravity differs between any two cells by more than 0.05, replace the battery.

#### NOTE

- **Hold the hydrometer tube vertical without removing it from the electrolyte.**
- **Do not suck too much electrolyte into the tube.**
- **Allow the float to move freely and hold the hydrometer at eye level.**
- **The hydrometer reading must be taken at the highest electrolyte level.**

#### (Reference)

- Specific gravity slightly varies with temperature. To be exact, the specific gravity decreases by 0.0007 with an increase of 1 °C (0.0004 with an increase of 1 °F) in temperature, and increases by 0.0007 with a decreases of 1 °C (0.0004 with a decrease of 1 °F).

Therefore, using 20 °C (68 °F) as a reference, the specific gravity reading must be corrected by the following formula :

- Specific gravity at 20 °C = Measured value + 0.0007 × (electrolyte temperature : 20 °C)
- Specific gravity at 68 °F = Measured value + 0.0004 × (electrolyte temperature : 68 °F)

Specific Gravity	State of Charge
1.260 Sp. Gr.	100 % Charged
1.230 Sp. Gr.	75 % Charged
1.200 Sp. Gr.	50 % Charged
1.170 Sp. Gr.	25 % Charged
1.140 Sp. Gr.	Very Little Useful Capacity
1.110 Sp. Gr.	Discharged

At an electrolyte temperature of 20 °C (68 °F)

**(a) Good**

**(b) Bad**

**(c) Bad**

W1019017

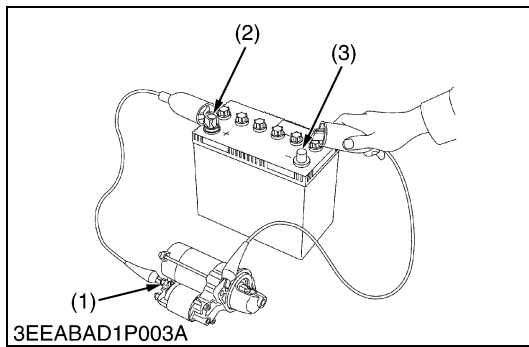

### Motor Test

#### ⚠ CAUTION

- **Secure the starter to prevent it from jumping up and down while testing the motor.**
1. Disconnect the battery negative cable from the battery.
  2. Disconnect the battery positive cable from the battery.
  3. Disconnect the leads from the starter **B** terminal.
  4. Remove the starter from the engine.
  5. Connect a jumper lead from the starter **C** terminal (1) to the battery positive terminal (2).
  6. Connect a jumper lead momentarily between the starter's body and the battery negative terminal (3).
  7. If the motor does not run, starter is failure.  
Repair or replace the starter.

#### ■ NOTE

- **B terminal** : It is the terminal which connects the cable from the battery to the starter.
- **C terminal** : It is the terminal which connects the cable from the motor to the magnet switch.

(1) C Terminal

(3) Negative Terminal

(2) Positive Terminal

W1019297

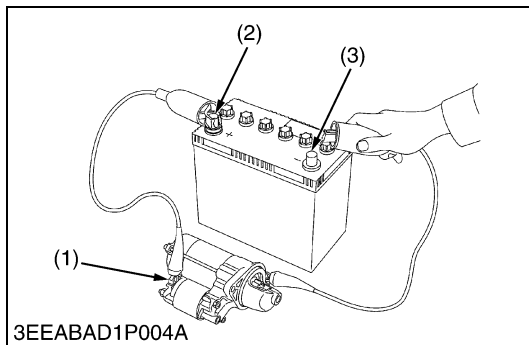

### Magnetic Switch Test

1. Disconnect the battery negative cable from the battery.
2. Disconnect the battery positive cable from the battery.
3. Disconnect the leads from the starter **B** terminal.
4. Remove the starter from the engine.
5. Connect a jumper lead from the starter **S** terminal (1) to the battery positive terminal (2).
6. Connect a jumper lead momentarily between the starter's body and the battery negative terminal (3).
7. If the pinion gear does not pop out, the magnetic switch is failure.  
Repair or replace the starter.

#### ■ NOTE

- **B terminal** : It is the terminal which connects the cable from the battery to the starter.
- **S terminal** : It is the terminal which connects the cable from the starter switch to the magnet switch.

(1) S Terminal

(3) Negative Terminal

(2) Positive Terminal

0000010743E

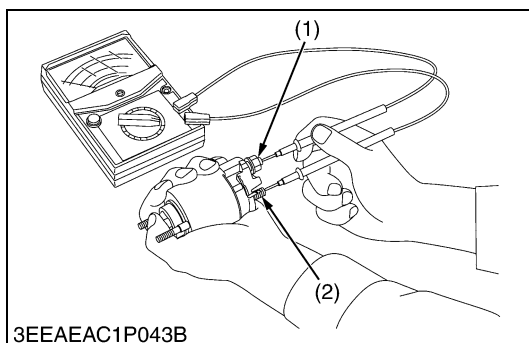

### Magnet Switch Continuity Test

1. Check the continuity across the **C** terminal (1) and the **B** terminal (2) with a circuit tester, pushing in the plunger.
2. If not continuous or if a certain value is indicated, replace the magnet switch.

(1) C Terminal

(2) B Terminal

0000010771E



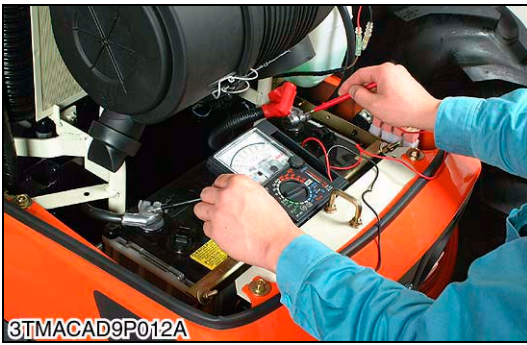

3TMACAD9P012A

**Alternator on Unit Test**

**(Before testing)**

- Before alternator on unit test, check the battery terminal connections, circuit connection, fan belt tension, charging indicator lamp, fuses on the circuit, and abnormal noise from the alternator.
- Prepare full charged battery for the test.

**NOTE**

- **Be careful not to touch the rotating engine parts while engine is running.**

**Keep safety distance from the engine rotating parts.**

1. Start the engine.
2. When the engine is operating measure the voltage between two battery terminals. If the voltage is between 13.8 V and 14.8 V, the alternator is operating normally.
3. If the results of alternator on unit test are not within the specifications, disassemble the alternator and check the each component part for finding out the failure. See the “DISASSEMBLING AND ASSEMBLING” and “SERVICING” for alternator.

Regulating voltage at no load	Factory spec.	13.8 to 14.8 V at 25 °C (77 °F)
-------------------------------	---------------	---------------------------------

0000010745E

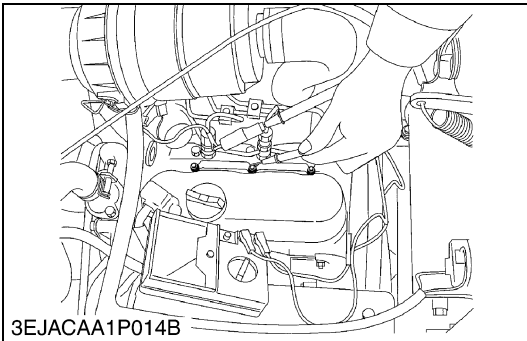

3EJACAA1P014B

**Glow Plug Lead Terminal Voltage**

1. Turn the key switch to the “**GLOW (or PREHEAT)**” position, and measure the voltage with a circuit tester between the lead terminal and the engine body.
2. If the voltage differs from the battery voltage, the wiring harness or main switch is faulty.

Voltage	Main switch key at <b>GLOW (or PREHEAT)</b>	Approx. battery voltage
---------	---	-------------------------

0000010725E

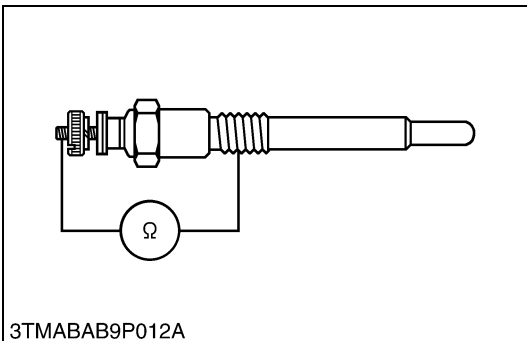

3TMABAB9P012A

**Glow Plug**

1. Remove the glow plug.
2. Measure the resistance with a circuit tester between the glow plug terminal and the glow plug housing.
3. If the factory specification is not indicated, glow plug is faulty.

Resistance	Factory spec.	Approx. 1.0 Ω
------------	---------------	---------------

Tightening torque	Glow plug	19.6 to 24.5 N·m 2.0 to 2.5 kgf·m 14.5 to 18.1 ft-lbs
-------------------	-----------	---

W1024626

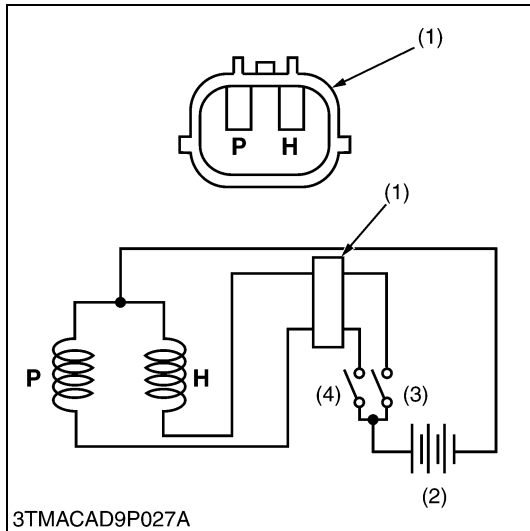

### Engine Stop Solenoid

1. Remove the engine stop solenoid from the engine.
2. Connect the jumper leads from the pulling coil **P** terminal to the switch (3), and from switch (3) to the battery positive terminal.
3. Connect the jumper leads from the holding coil **H** terminal to the switch (4), and from switch (4) to the battery positive terminal.
4. Connect the jumper leads from the engine stop solenoid body to the battery negative terminal.
5. When switch (4) is turn on, the plunger pull into the solenoid body and then turn off the switch (4), the plunger comes out.
6. Turn on the switch (3) then turn on the switch (4), the plunger pull into the solenoid body and it keep in holding position after turn off the switch (4).
7. If the plunger is not attracted, the engine stop solenoid is faulty.

#### ■ IMPORTANT

- Never apply the current for pulling coil more than two seconds when inspecting.

- (1) Connector
- (2) Battery
- (3) Switch for Holding Coil
- (4) Switch for Pulling Coil

**P : Terminal for Pulling Coil**  
**H : Terminal for Holding Coil**

W1020600

## (6) Turbocharger

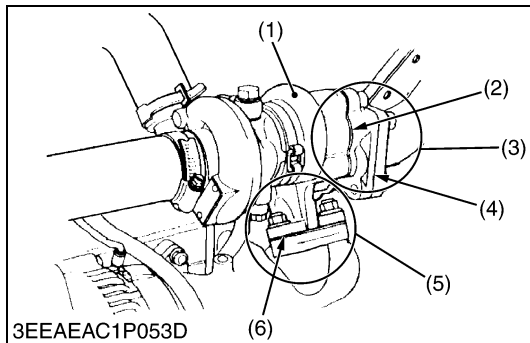

### Turbine Side

1. Check the exhaust port (3) and inlet port (5) side of turbine housing (1) to see if there is no exhaust gas leak.
2. If any gas leak is found, retighten the bolts and nuts or replace the gasket (2) / (4) / (6) with new one.

- (1) Turbine Housing
- (2) Gasket
- (3) Exhaust Port
- (4) Gasket
- (5) Inlet Port
- (6) Gasket

W1076917

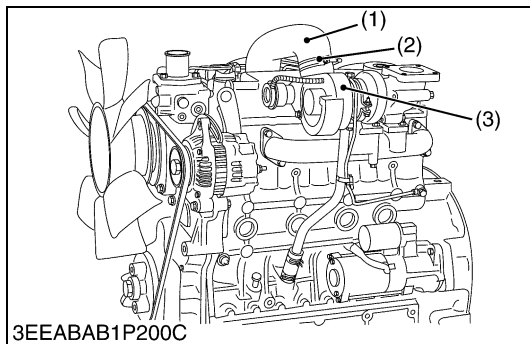

### Compressor Side

1. Check the inlet hose (1) of the compressor cover (3) to see if there is no air leak.
2. Check for loose connections or cracks in the suction side of the intake hose.
3. If any air leak is found, change the clamp (2) and or inlet hoses.

- (1) Inlet Hose
- (2) Clamp
- (3) Compressor Cover

W1077032

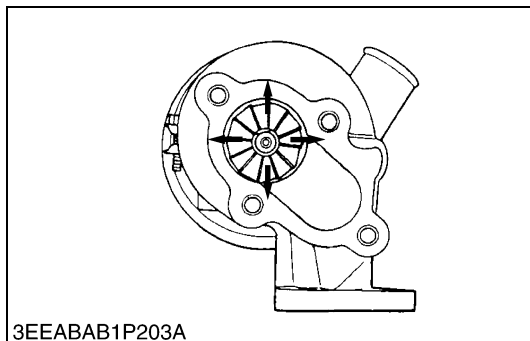

### Radial Clearance

1. If the wheel contact to the housing, replace the turbocharger assembly with new one.

W1077353

## [2] DISASSEMBLING AND ASSEMBLING

### (1) Draining Oil and Coolant

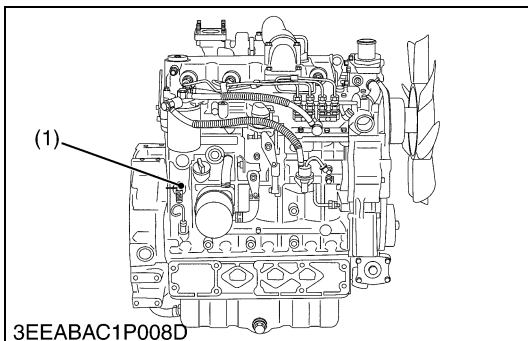
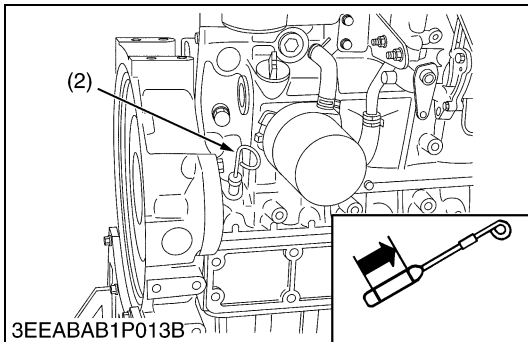
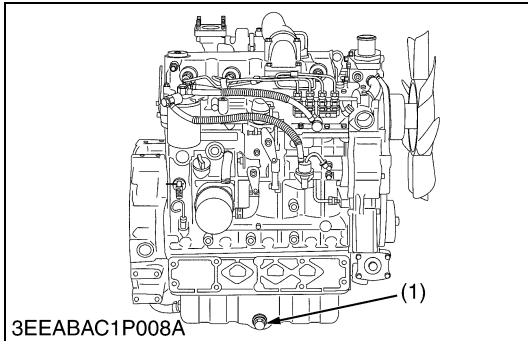

#### Draining Engine Oil

1. Start and warm up the engine for approx. 5 minutes.
2. Place an oil pan underneath the engine.
3. Remove the drain plug (1) to drain oil.
4. After draining, screw in the drain plug.

#### **(When refilling)**

- Fill the engine oil up to the upper line on the dipstick (2).

#### ■ **IMPORTANT**

- **Never mix two different types of oil.**
- **Use the proper SAE Engine Oil according to ambient temperature.**

(1) Drain Plug

(2) Dipstick

W1023464

#### Draining Coolant

#### ⚠ **CAUTION**

- **Never remove radiator cap while operating or immediately after stopping. Otherwise, hot water will spout out from the radiator. Wait for more than ten minutes to cool the radiator, before opening the cap.**

1. Prepare a bucket. Open the coolant drain cock.

(1) Coolant Drain Cock

W1023496

### (2) External Components

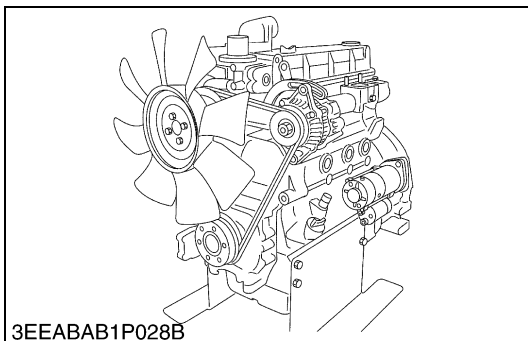

#### Air Cleaner, Muffler and Others

1. Remove the air cleaner and muffler.
2. Remove the fan, fan belt, alternator and starter.

#### **(When reassembling)**

- Check to see that there are no cracks on the belt surface.

#### ■ **IMPORTANT**

- **After reassembling the fan belt, be sure to adjust the fan belt tension.**
- **Do not confuse the direction of the fan. Attach the fan with its "1C010" marking facing forward (toward the radiator).**

W1049622

## CAUTION

- While the engine is running and or just after it stops, the turbocharger is hot, be careful not to touch the turbocharger.

## NOTE

- When detaching and attaching the turbocharger assembly, be very careful not to allow dust, dirt and other foreign matter in the oil pipes.
- When the turbocharger assembly has been replaced, pour fresh engine oil through the oil filler port of the turbocharger.
- Before starting the engine, make sure that air cleaner is in position.

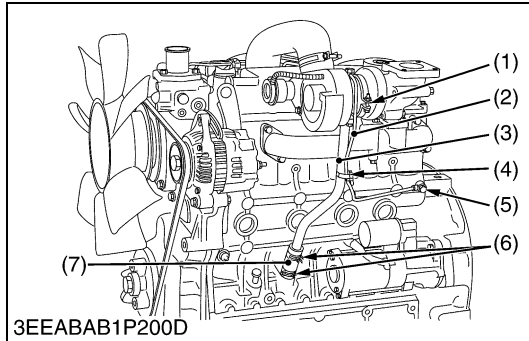

### Oil Pipe

1. Remove the joint bolt (5) and clamp (4) and take off the pipe 1 (2).
2. Remove the bolts (1) and release the clamp (6).
3. Disconnect the oil pipe 2 (7) and pipe 4 (3).

### **(When reassembling)**

- Pour fresh engine oil through the oil filler port of the turbocharger.
- Replace the gasket with new one.
- Be careful not to allow dust, dirt and other foreign matters in the oil pipes.

## NOTE

- **Tape or plug all openings to prevent foreign matters from damaging the oil cavities in the turbocharger.**

- |                |                |
|----------------|----------------|
| (1) Bolt       | (5) Joint Bolt |
| (2) Oil Pipe 1 | (6) Clamp      |
| (3) Oil Pipe 4 | (7) Oil Pipe 2 |
| (4) Clamp      |                |

W1025983

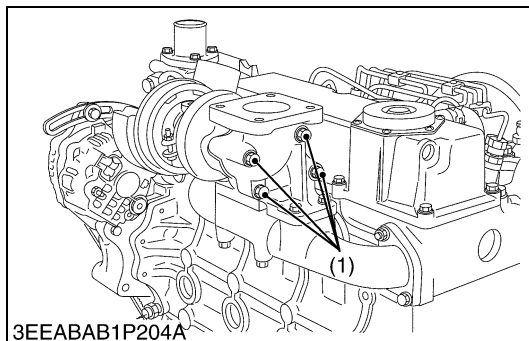

### Turbocharger

1. Remove the screw (1) and bolt (3).
2. Take off the turbocharger assembly (2).

### **(When reassembling)**

- Replace the gasket with new one.

- |                           |          |
|---------------------------|----------|
| (1) Screw                 | (3) Bolt |
| (2) Turbocharger Assembly |          |

W1078106

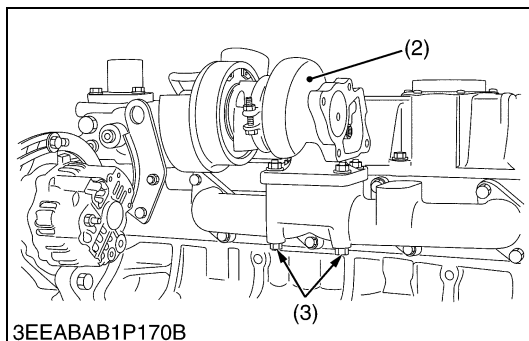

### (3) Cylinder Head and Valves

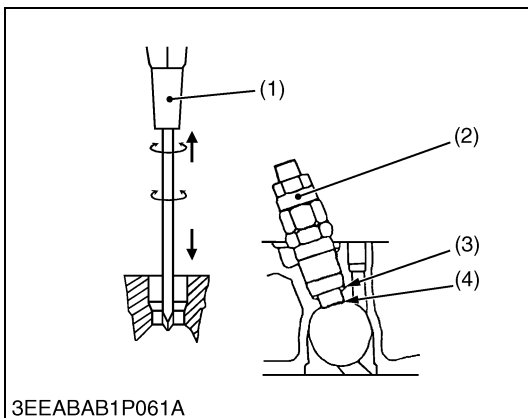
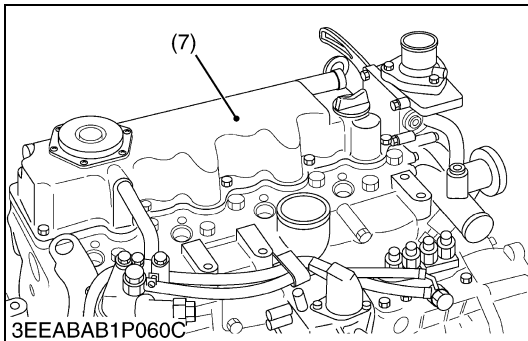
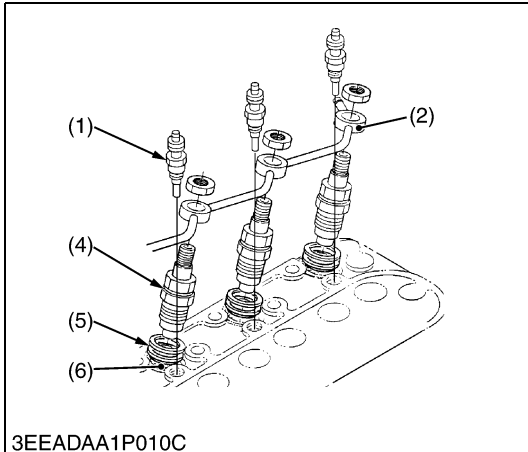
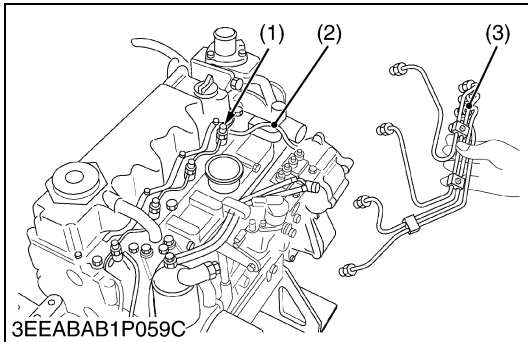

#### Cylinder Head Cover and Nozzle Holder

1. Remove the injection pipes (3) and overflow pipes (2).
2. Remove the glow plugs (1).
3. Remove the nozzle holder assembly (4) and copper gaskets (5).
4. Remove the heat seal (6).
5. Remove the head cover (7).

#### **(When reassembling)**

- Check to see that the cylinder head cover gasket is not defective.
- Be sure to place the heat seal.
- Tighten the head cover mounting bolts to specified torque.
- Mount the check valve with the ↓ mark toward the tank.

Tightening torque	Cylinder head cover screw	6.9 to 11.3 N-m 0.7 to 1.15 kgf-m 5.1 to 8.32 ft-lbs
	Injection pipe retaining nut	22.6 to 36.3 N-m 2.3 to 3.7 kgf-m 16.6 to 26.8 ft-lbs
	Nozzle holder assembly	49.0 to 68.6 N-m 5.0 to 7.0 kgf-m 36.2 to 50.6 ft-lbs
	Overflow pipe assembly retaining nut	19.6 to 24.5 N-m 2.0 to 2.5 kgf-m 14.5 to 18.1 ft-lbs
	Glow plug	19.6 to 24.5 N-m 2.0 to 2.5 kgf-m 14.5 to 18.1 ft-lbs

- |                            |                   |
|----------------------------|-------------------|
| (1) Glow Plug              | (5) Copper Gasket |
| (2) Overflow Pipe          | (6) Heat Seal     |
| (3) Injection Pipe         | (7) Head Cover    |
| (4) Nozzle Holder Assembly |                   |

W1049737

#### Nozzle Heat Seal Service Removal Procedure

##### ■ IMPORTANT

- Use a plus (phillips head) screw driver (1) that has a diameter which is bigger than the heat seal hole (Approx. 6 mm (1/4 in.)).

1. Drive screw driver (1) lightly into the heat seal hole.
2. Turn screw driver three or four times each way.
3. While turning the screw driver, slowly pull the heat seal (4) out together with the injection nozzle gasket (3).
4. If the heat seal drops, repeat the above procedure.

#### **(When reassembling)**

- Heat seal and injection nozzle gasket must be changed when the injection nozzle is removed for cleaning or for service.

- |                       |                             |
|-----------------------|-----------------------------|
| (1) Plus Screw Driver | (3) Injection Nozzle Gasket |
| (2) Injection Nozzle  | (4) Heat Seal               |

W1021255

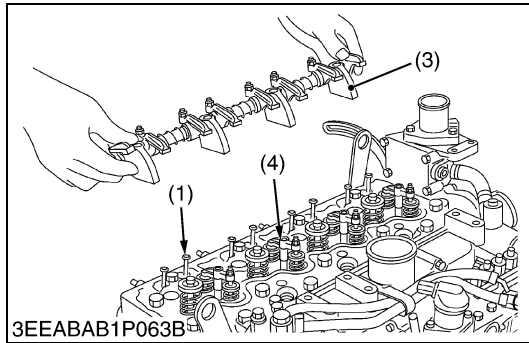
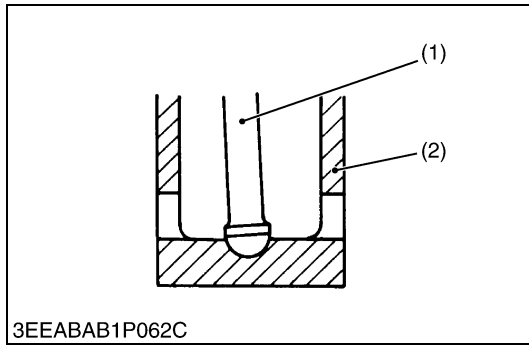

### Rocker Arm and Push Rod

1. Remove the rocker arm (3) as a unit.
2. Remove the push rods (1).
3. Remove the bridge arm (4).

#### (When reassembling)

- When putting the push rods onto the tappets (2), check to see if their ends are properly engaged with the grooves.

#### ■ IMPORTANT

- **After reassembling the rocker arm, be sure to adjust the valve clearance.**

Tightening torque	Rocker arm bracket screw	49.0 to 55.9 N·m 5.0 to 5.7 kgf·m 36.2 to 41.2 ft·lbs
-------------------	--------------------------	---

- (1) Push Rod  
(2) Tappet

- (3) Rocker Arm  
(4) Bridge Arm

W1050212

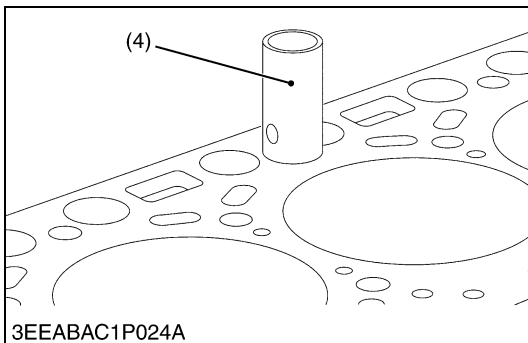
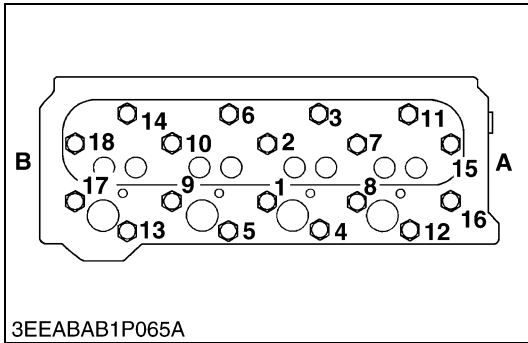
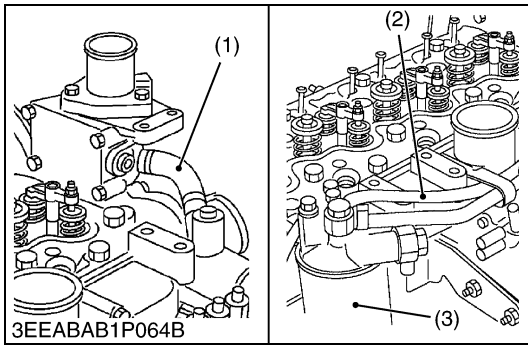

### Cylinder Head and Tappet

1. Loosen the pipe band, and remove the water return pipe (1).
2. Disconnect the fuel pipe (2) first and then the fuel filter (3).
3. Remove the IN. / EX. Manifold.
4. Remove the cylinder head screw in the order of (18) to (1), and remove the cylinder head.
5. Remove the cylinder head gasket.
6. Remove the tappets (4) from the crank case.

#### (When reassembling)

- Replace the head gasket with a new one.
- Before installing the tappets (4), apply engine oil thinly around them.
- When mounting the gasket, set it to the knock pin hole. Take care not to mount it reversely.
- The cylinder head should be free of scratches and dust.
- Take care for handling the gasket not to damage it.
- Install the cylinder head.
- Tighten the cylinder head screw gradually in the order of (1) to (18) after applying engine oil.
- Be sure to adjust the valve clearance. See the "Valve Clearance".
- It is not necessary to retighten the cylinder head screw after running the engine for 30 minutes.

#### ■ IMPORTANT

- **When replace the piston, piston pin bush, connecting rod or crankpin bearing, select the cylinder head gasket thickness to meet with the top clearance refer to the "Selecting Cylinder Head Gasket".**

#### ■ NOTE

- **Mark the cylinder number to the tappets to prevent interchanging.**

Tightening torque	Cylinder head mounting screw	98.1 to 107.9 N·m 10.0 to 11.0 kgf·m 72.3 to 79.6 ft·lbs
-------------------	------------------------------	--

- (1) Return Pipe
- (2) Fuel Pipe
- (3) Fuel Filter
- (4) Tappet

**A : Gear Case Side**  
**B : Flywheel Side**

W1170923

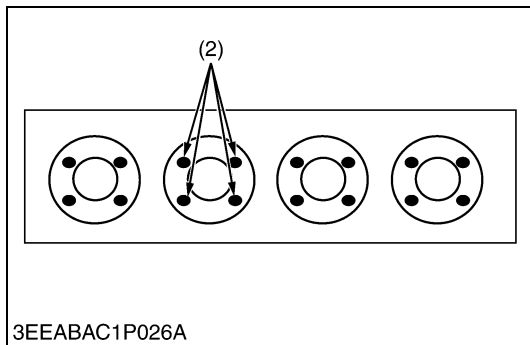
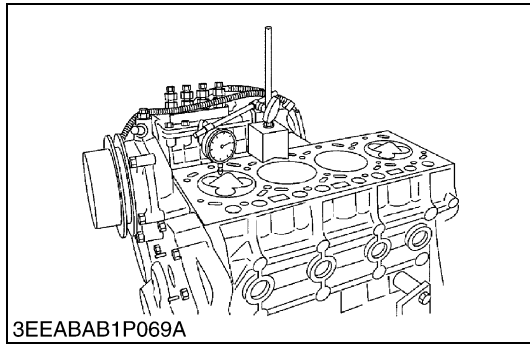
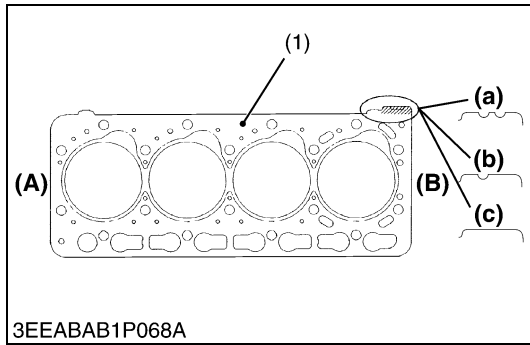

**Selecting Cylinder Head Gasket**

**Replacing the Cylinder Head Gasket**

1. Make sure the notch mark (a), (b) or (c) of cylinder head gasket (1) in advance.
2. Replace the same notch mark (a), (b) or (c) as the original cylinder head gasket (1).

**Selecting the Cylinder Head Gasket**

- Select the cylinder head gasket (1) thickness to meet with the top clearance when replacing the piston, piston pin bush, connecting rod or crankpin bearing.
1. Measure the piston head's protrusion or recessing from the crankcase cylinder face (4 spots per each piston and average of four pistons) using the dial gauge as shown in figure.
  2. Select the suitable cylinder head gasket refer to the table below.

Notch Mark of Cylinder Head Gasket	Thickness of cylinder head gasket		Part Code	Piston Head's protrusion or recessing from the level of Crankcase cylinder face. (average of 4 pistons)	
	Before tightening	After tightening		V3300-E2B	V3300-T-E2B
2 notches (a)	0.90 mm 0.0354 in.	0.80 mm 0.0315 in.	1C020-03310	-0.07 to +0.049 mm -0.0028 to +0.0019 in.	-0.27 to -0.151mm -0.0110 to -0.0059 in.
1 notch (b)	1.00 mm 0.0394 in.	0.90 mm 0.0354 in.	1C020-03600	+0.050 to +0.149 mm +0.0020 to +0.0058 in.	-0.15 to -0.051 mm -0.0059 to -0.0020 in.
Without notch (c)	1.05 mm 0.0413 in.	0.95 mm 0.0374 in.	1C020-03610	+0.150 to +0.20 mm +0.0059 to +0.0078 in.	-0.05 to 0 mm -0.0019 to 0 in.

- (1) Cylinder Head Gasket
- (2) Measuring Point
- (A) Gear Case Side
- (B) Flywheel Side
- (a) 2 Notches
- (b) 1 Notch
- (c) Without Notch

W1022965

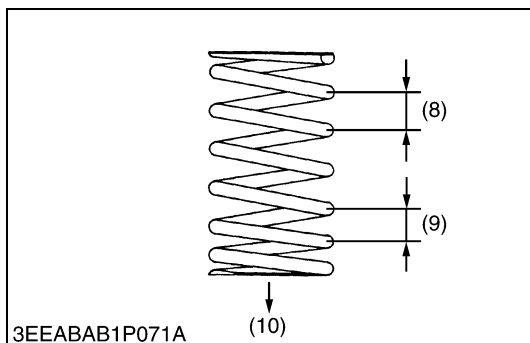
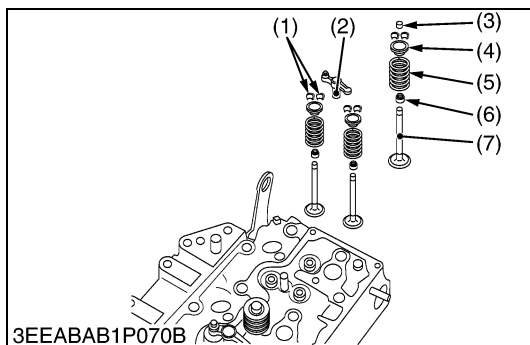

**Valve**

1. Remove the valve cap (3) and the valve spring collets (1) compressing the valve spring (5) with the valve spring retainer (4).

**(When reassembling)**

- Install the intake valve spring with its small-pitch end downward (at the head side).
- Wash the valve stem and valve guide hole, and apply engine oil sufficiently.
- After installing the valve spring collets, lightly tap the stem to assure proper fit with a plastic hammer.

- (1) Valve Spring Collet
- (2) Arm Bridge
- (3) Valve Cap
- (4) Valve spring Retainer
- (5) Valve Spring
- (6) Valve Stem Seal
- (7) Valve
- (8) Large Pitch
- (9) Smaller Pitch
- (10) Install the spring with its smaller-pitch end downward (at the head side)

W1053044



**(4) Thermostat**

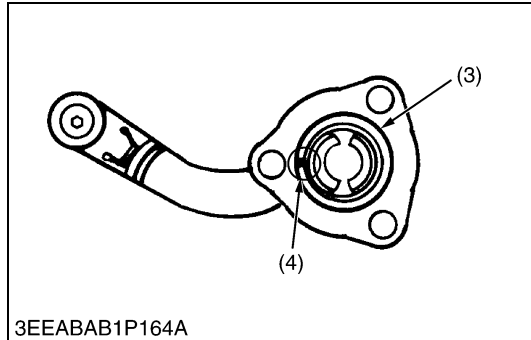
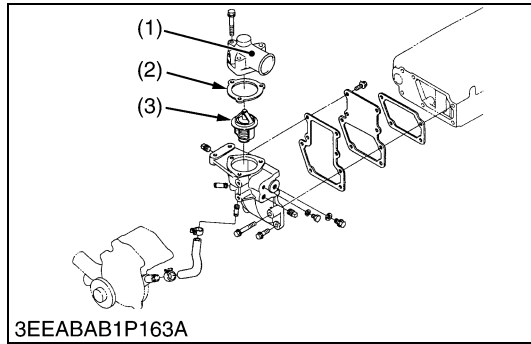

**Thermostat Assembly**

1. Remove the thermostat cover mounting screws, and remove the thermostat cover (1).
2. Remove the thermostat assembly (3).

**(When reassembling)**

- Apply a liquid gasket (Three Bond 1215 or equivalent) only at the thermostat cover side of the gasket (2).
- Attach the thermostat with its hole facing toward the air suction side.

- |                             |                         |
|-----------------------------|-------------------------|
| (1) Thermostat Cover        | (3) Thermostat Assembly |
| (2) Thermostat Cover Gasket | (4) Hole                |

W1072747

**(5) Injection Nozzle**

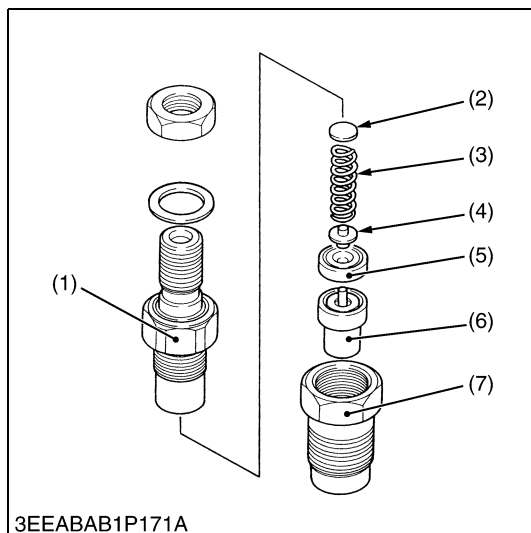

**Nozzle Holder**

1. Secure the nozzle retaining nut (7) with a vise.
2. Remove the nozzle holder (1), and take out parts inside.

**(When reassembling)**

- Assemble the nozzle in clean fuel oil.
- Install the push rod (4), noting its direction.
- After assembling the nozzle, be sure to adjust the fuel injection pressure.

Tightening torque	Nozzle holder	34.3 to 39.2 N·m 3.5 to 4.0 kgf·m 25.3 to 28.9 ft-lbs
	Overflow pipe nut	19.6 to 24.5 N·m 2.0 to 2.5 kgf·m 14.5 to 18.1 ft-lbs
	Nozzle holder assembly	49.0 to 68.6 N·m 5.0 to 7.0 kgf·m 36.2 to 50.6 ft-lbs

- |                      |                          |
|----------------------|--------------------------|
| (1) Nozzle Holder    | (5) Distance Piece       |
| (2) Adjusting Washer | (6) Nozzle Piece         |
| (3) Nozzle Spring    | (7) Nozzle Retaining Nut |
| (4) Push Rod         |                          |

W1089102

## (6) Injection Pump Unit

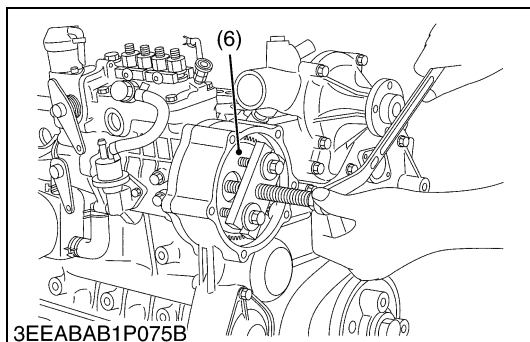
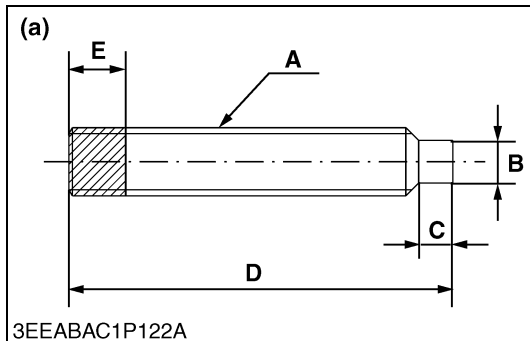
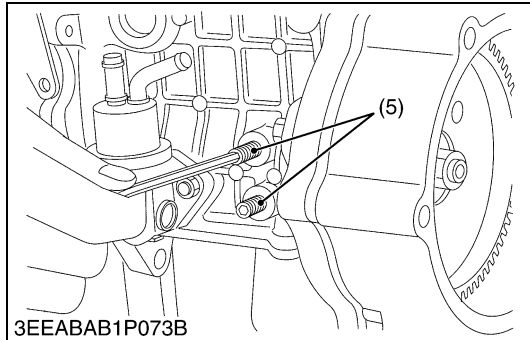
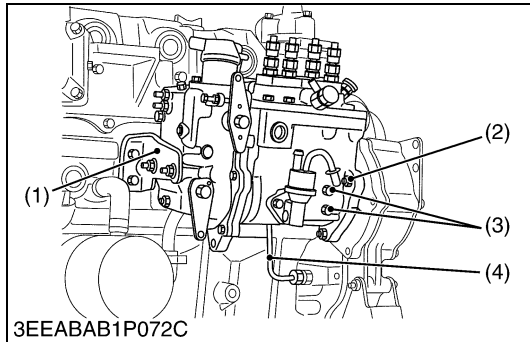

### Injection Pump Unit

#### (Removing the fuel injection pump unit)

1. Detach the gear cover for the fuel injection pump unit from the gearcase.
2. Place the piston of the 4th cylinder at the top dead center in the compression stroke. Fix the flywheel with the flywheel stopper.

#### ■ IMPORTANT

- Look for the align mark on the idle gear 2. Using a white marking pen or the like, put an align mark on the engaged tooth of the idle gear. This helps to reassemble these gears in mesh later.

#### ■ NOTE

- When the already existing align marks align with each other, there is no need to put another align mark.
3. Unscrew the two plugs (3) of the injection pump unit.
  4. Tighten the upper fuel cam shaft lock screw (5) until it comes into contact with the fuel cam shaft. Make sure the cam shaft does not move any longer.
  5. Tighten the lower fuel cam shaft lock screw (5) until it comes into contact with the fuel cam shaft.

#### ■ NOTE

- Never overtighten the lock screws when they have come into contact with the cam shaft. Otherwise the injection pump itself may get damaged.
  - Use of a socket set screw (dog point type) is recommended for best results. Such screw can be constructed as shown in figure (a).
6. Loosen the injection pump gear mounting nut. Using the specific gear puller, take out the gear (6).

#### ■ NOTE

- Be careful not to drop the key.
7. Disconnect the lubricating oil pipe (4).
  8. Loosen the three injection pump unit mounting nut (2).
  9. Remove the injection pump unit support (1) and take out the injection pump unit.

A	M8 × Pitch 1.25
B	5 mm dia. (0.197 in. dia.)
C	4 mm (0.157 in.)
D	45 mm (1.772 in.)
E	10 mm (0.39 in.) : Conspicuously Painted

- |                                      |  |
|--------------------------------------|--|
| (1) Injection Pump Unit Support      | (4) Lubricating Oil Pipe   |
| (2) Injection Pump Unit Mounting Nut | (5) Fuel Cam Shaft Lock Screw<br>(Socket Set Screw Dog Point Type) |
| (3) Plug                             | (6) Injection Pump Gear  |

W1175054

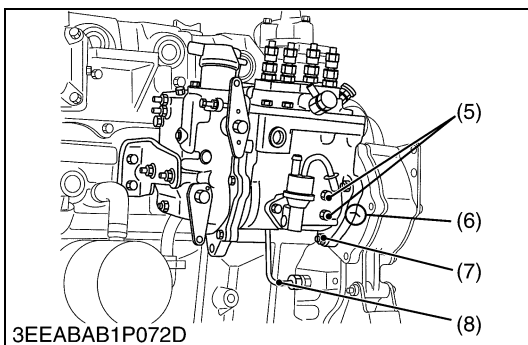
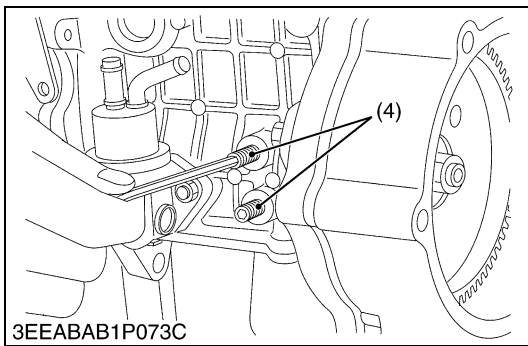
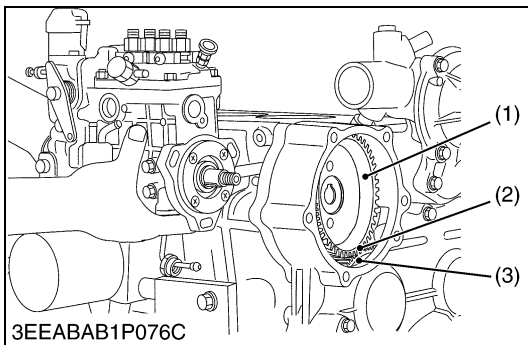

### Injection Pump Unit (Continued)

#### (Reassembling the fuel injection pump unit)

1. Place the piston of the 4th cylinder at the top dead center in the compression stroke. Fix the flywheel with the flywheel stopper.
2. Place the injection pump gear (1) back into the gear case position. Make sure of aligning the align marks of the injection pump gear (1) and the idle gear 2 (3).
3. Install the injection pump unit to the injection pump gear (1).

#### ■ NOTE

- When installing the injection pump unit to the injection pump gear, make sure that the key is fit in the keyway of injection pump gear.
4. Temporarily tighten the injection pump gear mounting nut by hand.
  5. Fix the injection pump unit and tighten the injection pump gear mounting nut to the specified torque.
  6. Take off the fuel cam shaft lock screws (4) and tighten the plugs (5) for plugging.
  7. Loose the injection pump unit mounting nuts (7) for aligning the injection timing.
  8. Moving the injection pump unit clockwise (viewed from gear case side), align the injection timing marks (6) on the injection pump unit and on the gear case.
  9. Tighten the injection pump unit mounting nut (7) to the specified torque.
  10. Reconnect the lubricating oil pipe (8) and place the injection pump unit support and the gear cover of the injection pump unit.
  11. Remove the flywheel stopper.
  12. Check the injection timing. (See the "Injection Timing".)
  13. If the injection timing is not within the specification, repeat (7) to (12) again.

Tightening torque	Injection pump gear mounting nut	73.6 to 83.4 N·m 7.5 to 8.5 kgf·m 54.2 to 61.5 ft-lbs
	Injection pump unit mounting nut	17.7 to 20.6 N·m 1.8 to 2.1 kgf·m 13.0 to 15.2 ft-lbs

- |  |                                      |
|--|--------------------------------------|
| (1) Injection Pump Gear  | (5) Plug                             |
| (2) Align mark of the Injection Gear                               | (6) Align Mark                       |
| (3) Idle Gear 2  | (7) Injection Pump Unit Mounting Nut |
| (4) Fuel Cam Shaft Lock Screw<br>(Socket Set Screw Dog Point Type) | (8) Lubricating Oil Pipe             |

W1176586

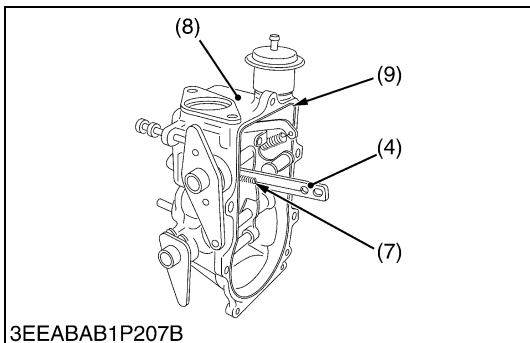
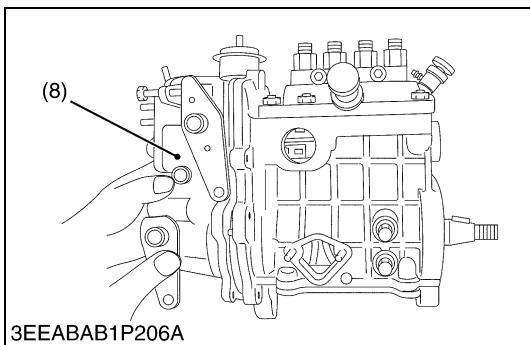
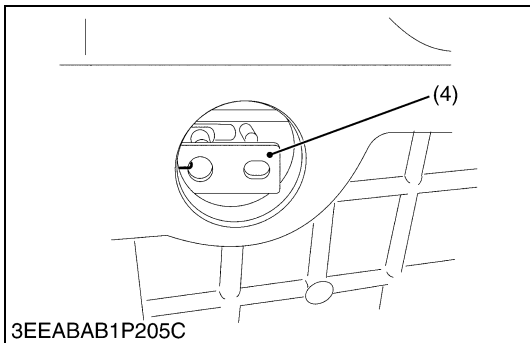
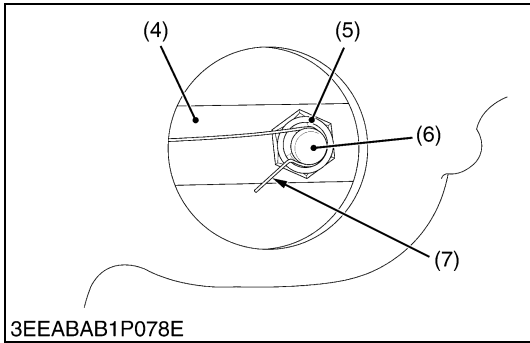
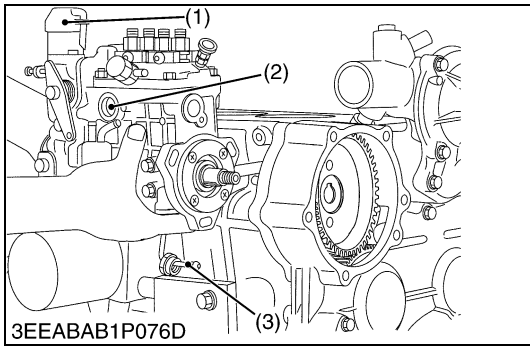

**Governor Housing Assembly**

1. Remove the injection pump unit from the engine. (See the "Injection Pump Unit".)
  2. Remove the governor lubricating pipe (3).
  3. Remove the stop solenoid (1).
  4. Detach the sight cover (2) from the injection pump unit.
  5. Unhook the start spring (7) from the rack pin (6) of injection pump assembly.
  6. Remove the nut (5).
- **NOTE**
- **Be careful not to drop the nut inside.**
7. Slide off the governor connecting rod (4) from the rack pin of injection pump assembly.
  8. For convenient sake, temporarily hook the start spring on the rack pin hole of the governor connecting rod.
  9. Remove the governor housing mounting screws.
  10. Detach the governor housing assembly (8) from the injection pump unit.

**(When reassembling)**

- When reassembling the inside parts, put the oil on each inside part slightly.
- After sliding on the governor connecting rod to the rack pin, tighten the nut with the specified torque with using the jig for keeping the governor connecting rod horizontal. (See the Replacing Injection Pump Assembly.)
- After tightening the nut, hook the start spring on the rack pin.
- Check the movement of control rack of injection pump assembly by the stop lever.

■ **NOTE**

- **When installing the governor housing assembly to the injection pump unit, be careful not to damage O-ring (9).**
- **When linking the governor connecting rod to the rack pin of injection pump, use the jig for keeping the governor connecting rod horizontal. Otherwise the control rack may be stuck, and causes to be difficult to start the engine or hunting of governor. (See the Replacing Injection Pump Assembly.)**

Tightening torque	Governor housing mounting screw	9.8 to 11.3 N·m 1.00 to 1.15 kgf·m 7.23 to 8.32 ft·lbs
	Anti-rotation nut	2.8 to 4.0 N·m 0.29 to 0.41 kgf·m 2.1 to 3.0 ft·lbs

- |                               |                               |
|-------------------------------|-------------------------------|
| (1) Stop Solenoid             | (6) Rack Pin                  |
| (2) Sight Cover               | (7) Start Spring              |
| (3) Governor Lubricating Pipe | (8) Governor Housing Assembly |
| (4) Governor Connecting Rod   | (9) O-ring                    |
| (5) Anti-Rotation Nut         |                               |

W1137126

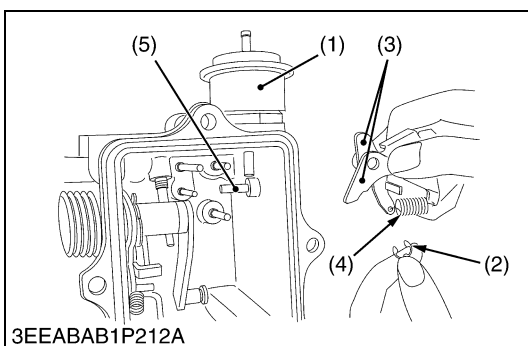
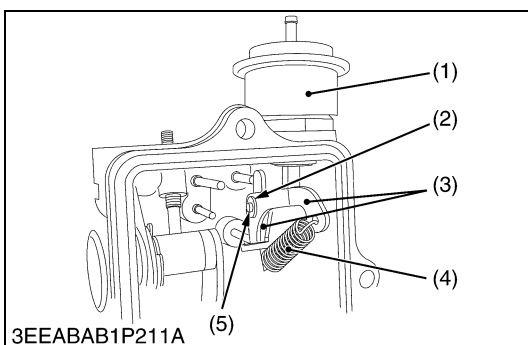
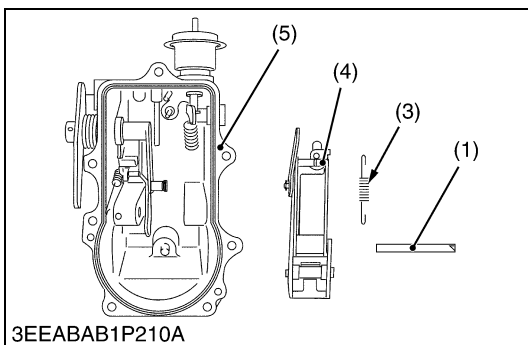
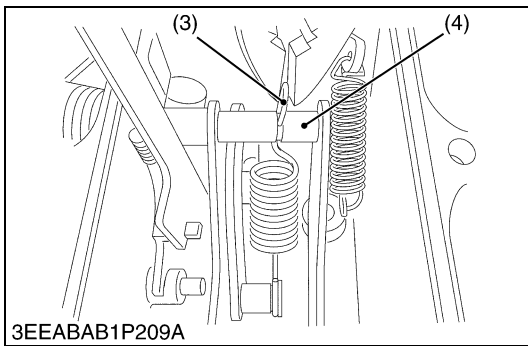
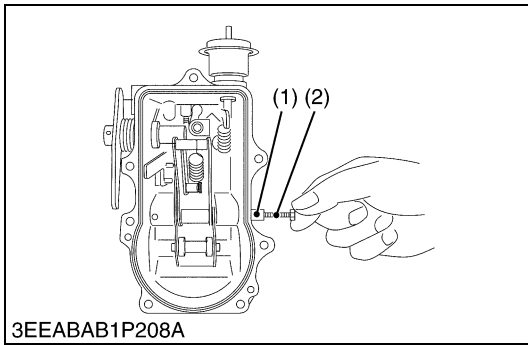

### Governor Fork Lever Assembly

1. Pull off the governor fork lever shaft (1) with the extra bolt (Dia : 4 mm, Pitch : 0.7 mm, Length : more than 25 mm) (2).
2. Unhook the governor spring (3) at the governor fork lever (4) side.
3. Remove the governor fork lever assembly from the governor housing (5).

#### (When reassembling)

- After reassembling the governor housing assembly, check the movement of the governor fork lever assembly, the speed control lever and the stop lever.

#### ■ NOTE

- When assembling the inside parts, put the oil on each inside part slightly.
- Be careful not to deform the start spring.

- |   |                         |
|---|-------------------------|
| (1) Governor Fork Lever Shaft   | (3) Governor Spring     |
| (2) Extra Bolt<br>(Dia : 4 mm, Pitch : 0.7 mm,<br>Length : more than 25 mm) | (4) Governor Fork Lever |
|   | (5) Governor Housing    |

W1139749

### Boost Arms (If equipped Boost Compensator)

1. Remove the boost actuator (1).
2. Remove the cir-clip (2).
3. Remove the boost arms (3) and the boost spring (4) from the pin (5).

Tightening torque	Boost actuator	39.2 to 45.1 N·m 4.0 to 4.6 kgf·m 28.9 to 33.3 ft·lbs

- |                    |                  |
|--------------------|------------------|
| (1) Boost Actuator | (4) Boost Spring |
| (2) Cir-clip       | (5) Pin          |
| (3) Boost Arm      |                  |

W1141511

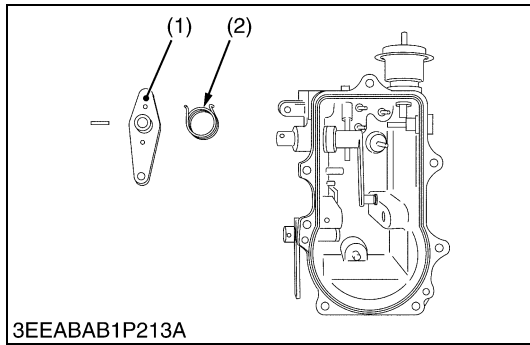
**Governor Lever**

1. Remove the speed control lever (1) and the return spring (2).
2. Remove the governor lever assembly (4) from the governor housing.
3. Remove the start spring (5) and the stop spring (3).

- |                         |                             |
|-------------------------|-----------------------------|
| (1) Speed Control Lever | (4) Governor Lever Assembly |
| (2) Return Spring       | (5) Start Spring            |
| (3) Stop Spring         |                             |

W1142375

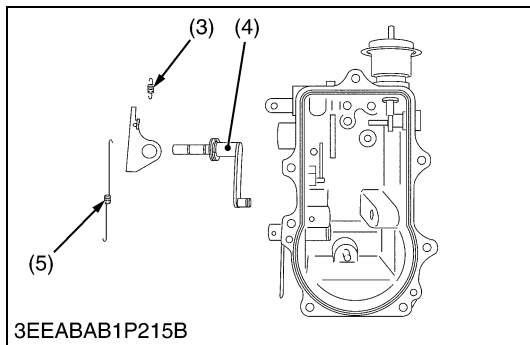
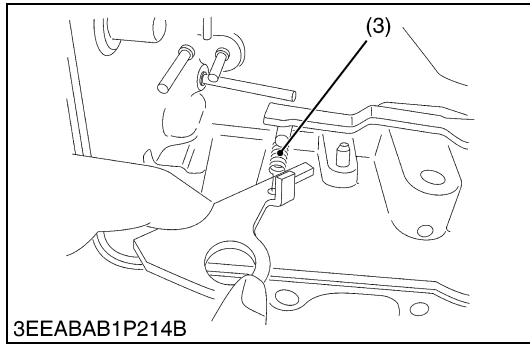
**Stop Lever**

1. Remove the stop lever (1) and the return spring (2).
2. Remove the stop lever shaft (3).

- |                   |                      |
|-------------------|----------------------|
| (1) Stop Lever    | (3) Stop Lever Shaft |
| (2) Return Spring |                      |

W1143531

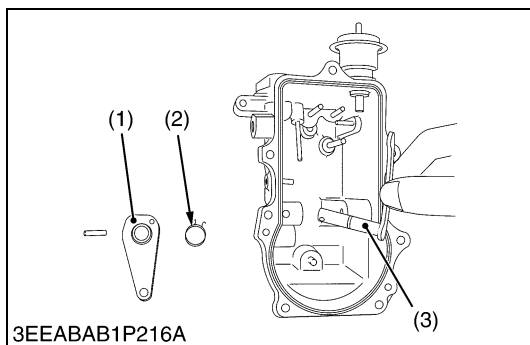

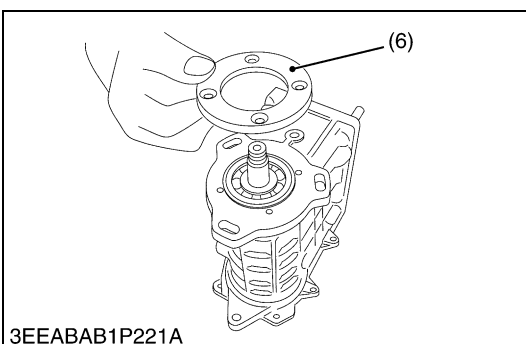
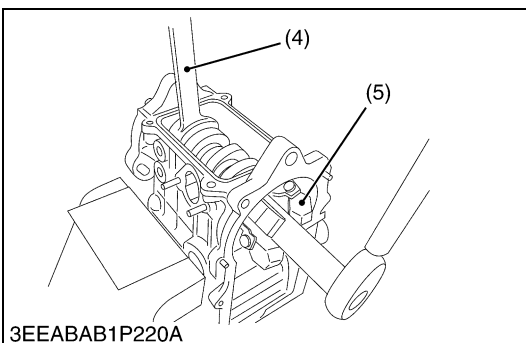
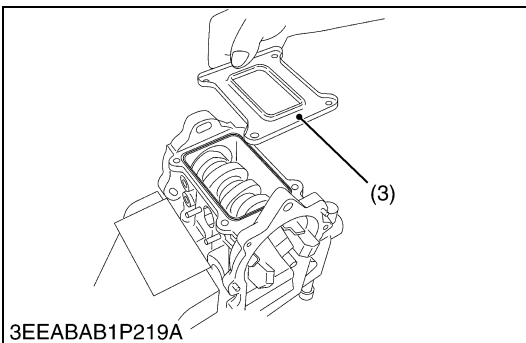
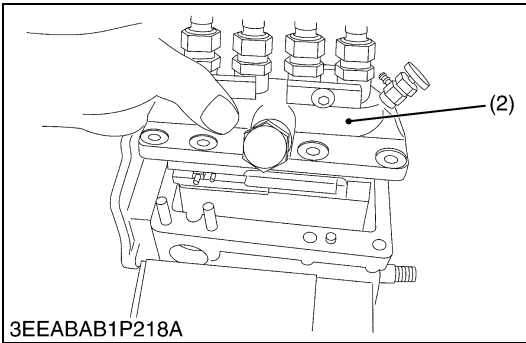
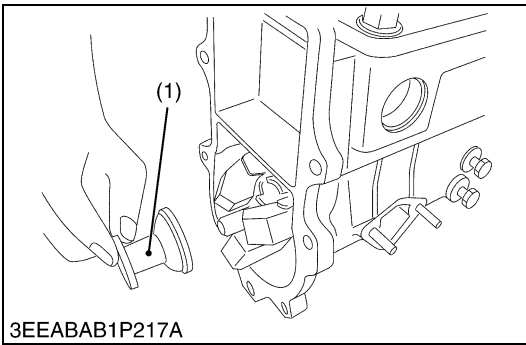

### Fuel Camshaft and Governor Weight

1. Separate the governor housing assembly from the injection pump unit. (See the "Injection Pump Unit".)
2. Remove the governor sleeve (1).
3. Remove the injection pump assembly (2).
4. Remove the cover (3).
5. Remove the fuel camshaft lock screws.
6. Fix the fuel camshaft with open end wrench (4), and remove the governor weight mounting nut and the governor weight (5).
7. Loosen the fuel camshaft stopper mounting screws and remove the fuel camshaft stopper (6).
8. Pull out the fuel camshaft (9) and bearings (7) together.
9. After removing the bearing's cir-clip (8), press out the bearings.

#### NOTE

- Do not use the fuel camshaft lock screws, when removing the governor weight mounting nut. Otherwise, the lock bolts or injection pump housing might get damage.

#### (When reassembling)

- Press the bearings into the fuel camshaft.
- Set the cir-clip at the gear side's bearing.
- Install the fuel camshaft and bearings to the injection pump housing.
- Attach the fuel camshaft stopper and tighten the fuel camshaft stopper mounting screws with the specified torque.
- Attach the governor weight to the fuel camshaft and tighten the governor weight mounting nut with specified torque.

Tightening torque	Injection pump mounting screw	23.5 to 27.5 N·m 2.4 to 2.8 kgf·m 17.4 to 20.3 ft·lbs
	Injection pump mounting nut	17.7 to 20.6 N·m 1.8 to 2.1 kgf·m 13.0 to 15.2 ft·lbs

- |                             |                               |
|-----------------------------|-------------------------------|
| (1) Governor Sleeve         | (6) Fuel Camshaft Stopper     |
| (2) Injection Pump Assembly | (7) Bearing                   |
| (3) Cover                   | (8) Cir-clip                  |
| (4) Open End Wrench (24 mm) | (9) Fuel Camshaft             |
| (5) Governor Weight         | (10) Key Way of Fuel Camshaft |

W1144178

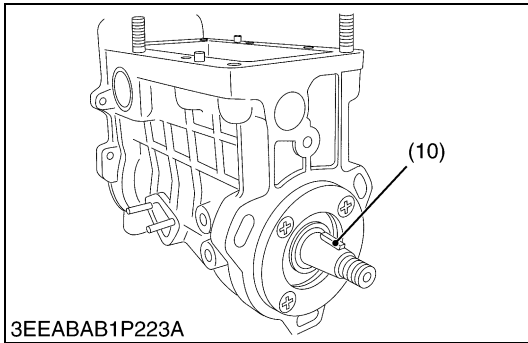
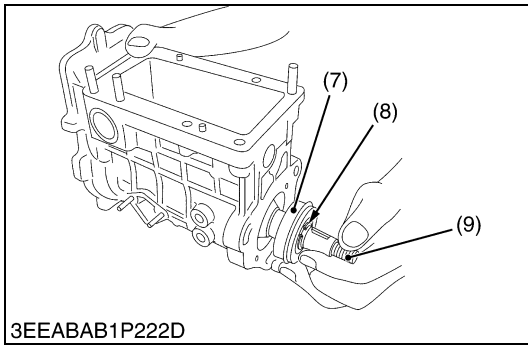

**Fuel Camshaft and Governor Weight (Continued)**

**(When reassembling)**

- Fix the fuel camshaft with lock bolts as the key way of fuel camshaft (10) is upward.
- Install the injection pump assembly to the injection pump housing.
- Attach the O-ring and the cover and tighten the cover mounting screws.
- Install the governor sleeve to the fuel camshaft.
- Check the movement of the governor sleeve.

**NOTE**

- **Be careful not to damage the O-ring.**
- **Be careful the direction of the governor sleeve.**
- **When reassembling the inside parts, put the oil on each inside part slightly.**

Tightening torque	Fuel camshaft stopper mounting screw	7.9 to 9.3 N·m 0.80 to 0.95 kgf·m 5.8 to 6.9 ft·lbs
	Governor weight mounting nut	62.8 to 72.6 N·m 6.4 to 7.4 kgf·m 46.3 to 53.5 ft·lbs

- |                             |                               |
|-----------------------------|-------------------------------|
| (1) Governor Sleeve         | (6) Fuel Camshaft Stopper     |
| (2) Injection Pump Assembly | (7) Bearing                   |
| (3) Cover                   | (8) Cir-clip                  |
| (4) Open End Wrench (24 mm) | (9) Fuel Camshaft             |
| (5) Governor Weight         | (10) Key Way of Fuel Camshaft |

W1146489



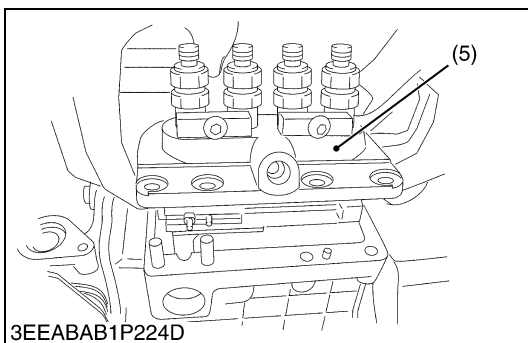
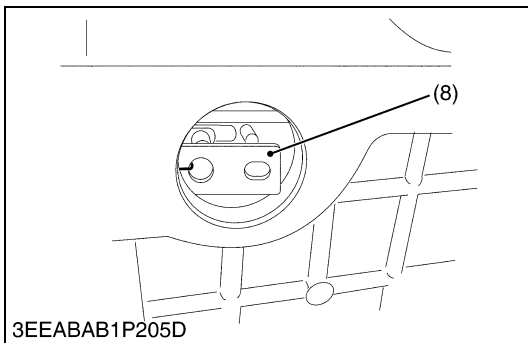
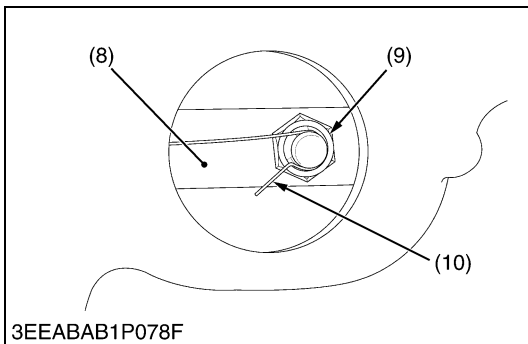
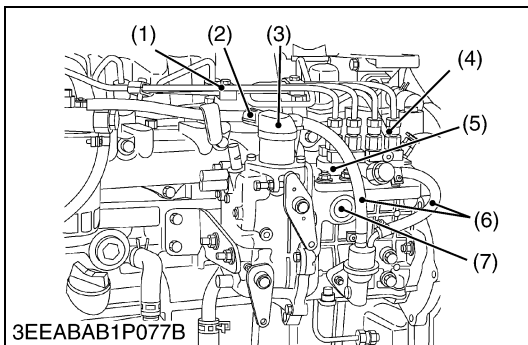

### Replacing Injection Pump Assembly (If necessary)

- The injection pump can be replaced with the crankshaft in whatever position.

1. Disconnect all injection pipes (1).
2. Disconnect the fuel pipe (6) and fuel overflow pipe (4).
3. Disconnect the connector (2) from the stop solenoid. Then remove the stop solenoid (3).
4. Detach the sight cover (7) from the injection pump unit.
5. Unhook the start spring (10), and remove the anti-rotation nut (9).
6. Slide off the governor connecting rod (8) from the rack pin of injection pump assembly.
7. Remove the injection pump mounting screws and nuts, and take out the injection pump assembly (5).

#### ■ NOTE

- Be careful not to drop the anti-rotation nut (9).
- Be careful not to deform the start spring.
- When taking out the injection pump assembly, be careful not to hit it against the governor connecting rod.

#### (When reassembling)

- Install the new injection pump according to the installing procedure.

- |                             |                             |
|-----------------------------|-----------------------------|
| (1) Injection Pipe          | (6) Fuel Pipe               |
| (2) Connector               | (7) Sight Cover             |
| (3) Stop Solenoid           | (8) Governor Connecting Rod |
| (4) Fuel Overflow Pipe      | (9) Anti-Rotation Nut       |
| (5) Injection Pump Assembly | (10) Start Spring           |

W1182379

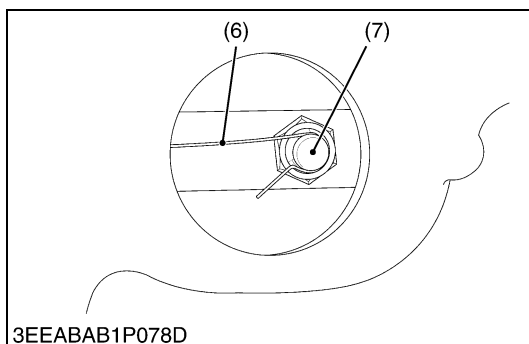
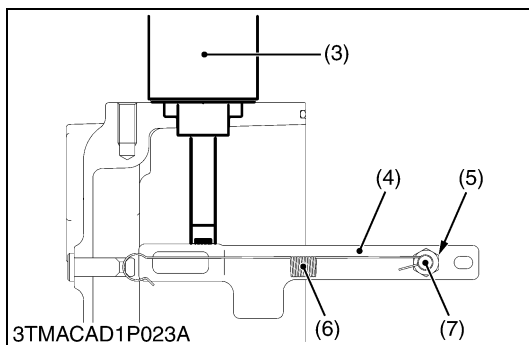
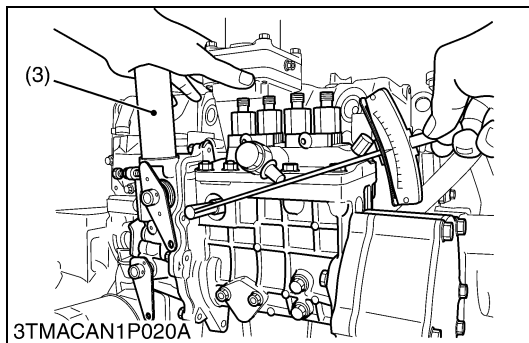
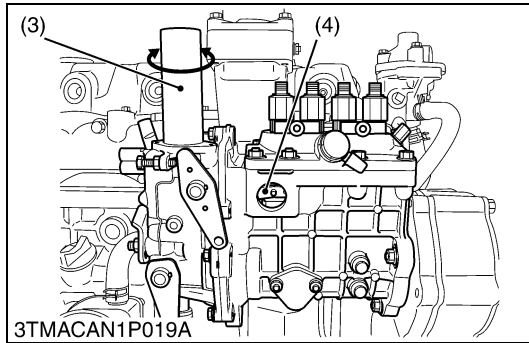
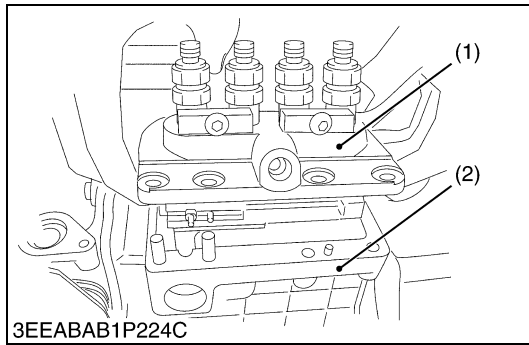

### Installing Procedure of Injection Pump Assembly

1. Install the fuel injection pump assembly (1) in its unit (2), and hook the governor connecting rod to the rack pin of the fuel injection pump assembly.
2. Place the service jig (3) in the stop solenoid mounting hole of the fuel injection pump unit.
3. Make sure the permanent magnet at the tip of the service jig is attracted to the governor connecting rod (4). To do this, turn the jig a little clockwise and counterclockwise and look into the fuel injection pump unit sight hole to see if the governor connecting rod (4) moves right and left accordingly.
4. Slightly tighten the anti-rotation nut of the governor connecting rod.
5. Holding down the service jig (3) by hand, tighten up the anti-rotation nut (5) to the specified torque.
6. Hook the start spring (6) to the rack pin (7).

- |                                  |                       |
|----------------------------------|-----------------------|
| (1) Fuel Injection Pump Assembly | (5) Anti-rotation Nut |
| (2) Fuel Injection Pump Unit     | (6) Start Spring      |
| (3) Service Jig                  | (7) Rack Pin          |
| (4) Governor Connecting Rod      |                       |

W1069371

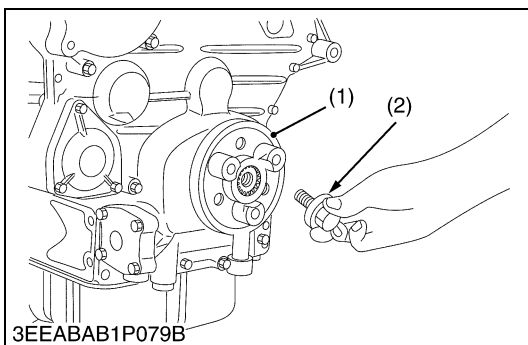
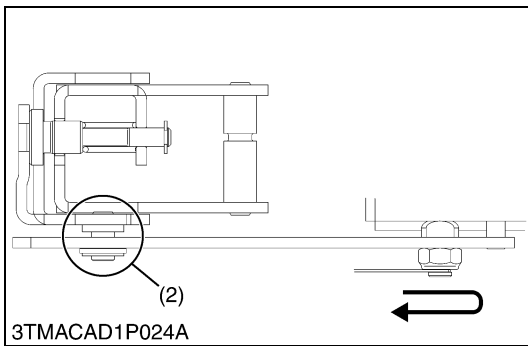
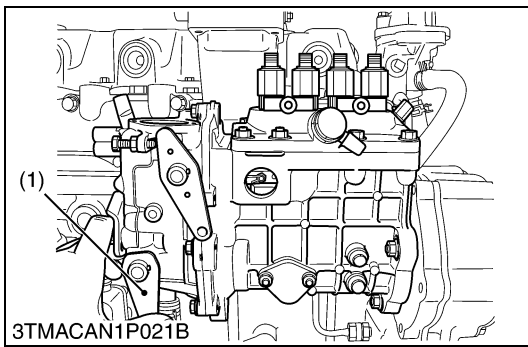

**Installing Procedure (Continued)**

1. Move the stop lever (1) and visually check to see if the fuel injection pump control rack comes smoothly back to the start position by the counter force of the start spring.
2. If the control rack fails to move back smoothly, remove the start spring and the anti-rotation nut, take the above steps from 2 of the former page again.
3. Finally fit the sight cover and the stop solenoid back into place.

Tightening torque	Anti-rotation nut	2.8 to 4.0 N·m 0.29 to 0.41 kgf·m 2.1 to 3.0 ft-lbs
	Injection pump mounting screw	23.5 to 27.5 N·m 2.4 to 2.8 kgf·m 17.4 to 20.3 ft-lbs
	Injection pump mounting nut	17.7 to 20.6 N·m 1.8 to 2.1 kgf·m 13.0 to 15.2 ft-lbs

(1) Stop Lever

(2) Sliding Point between Governor Fork Lever and Governor Connecting Rod

W1069772

**Fan Drive Pulley**

1. Set the stopper to the flywheel.
2. Remove the crankshaft screw (2).
3. Draw out the fan drive pulley (1).

**(When reassembling)**

Tightening torque	Crankshaft screw	255.0 to 274.6 N·m 26.0 to 28.0 kgf·m 188.1 to 202.5 ft-lbs
-------------------	------------------	---

(1) Fan Drive Pulley

(2) Crankshaft Screw

W1185033

**(7) Water Pump and Oil Cooler**

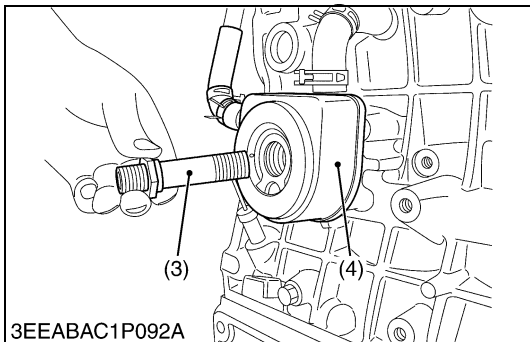
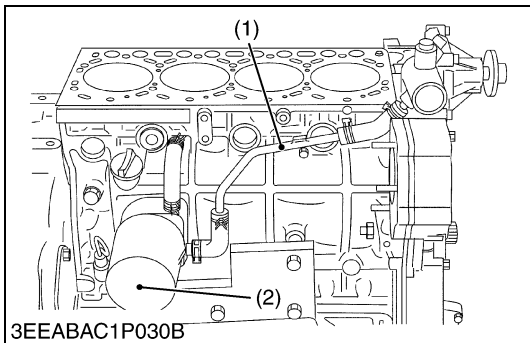
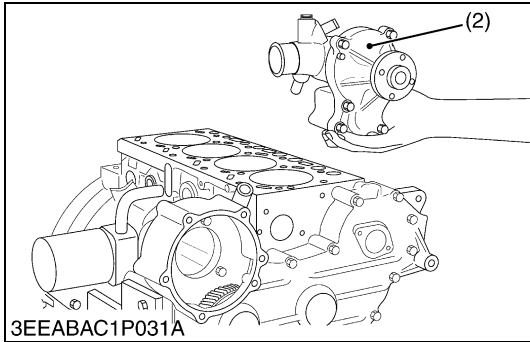
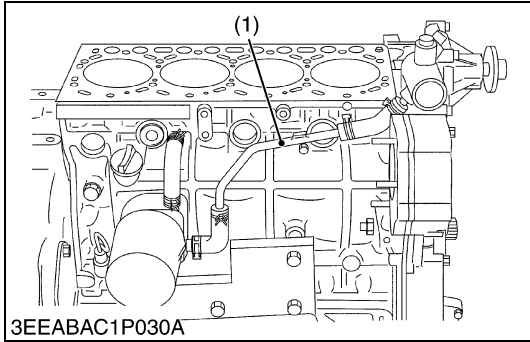

**Water Pump**

1. Remove the pipe band and the water pipe (1).
2. Remove the water pump (2).

**(When reassembling)**

- When mounting the water pump, take care not to forget mounting the O-ring and not to let it out of position.

- (1) Water Pipe (2) Water Pump

W1187742

**Oil Cooler**

1. Remove the water pipe (1).
2. Remove the oil filter cartridge (2) and the oil cooler joint screw (3).
3. Remove the oil cooler (4).

Tightening torque	Oil cooler joint screw	39.2 to 44.1 N·m 4.0 to 4.5 kgf·m 28.9 to 32.5 ft·lbs
-------------------	------------------------	---

- (1) Water Pipe (2) Oil Filter Cartridge (3) Oil Cooler Joint Screw (4) Oil Cooler

W1032266

### (8) Gear Case and Timing Gears

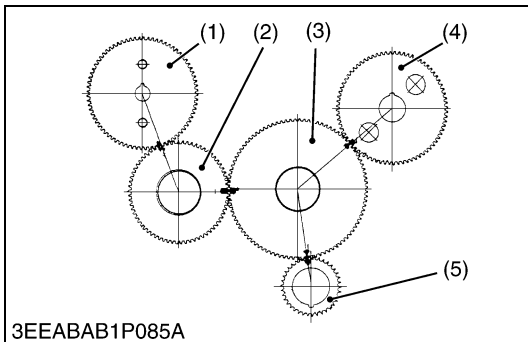
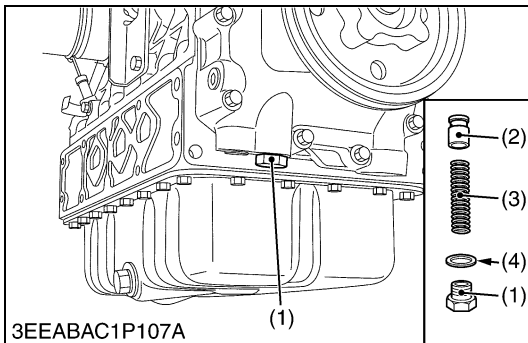
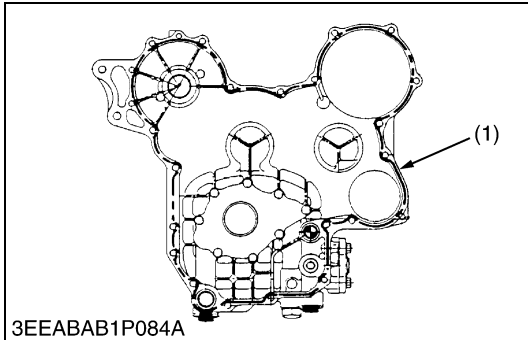
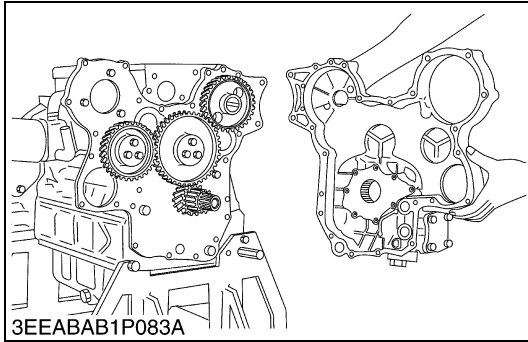

#### Gear Case Cover

1. Remove the gear case cover.

#### (When reassembling)

- Confirm that the liquid gasket coating surface is free of water, dust and oil in order to maintain sealing effect.
- Carefully apply the adhesive evenly. (Refer to the figure on the left.)

#### NOTE

- When mounting the adhesive-applied parts, take care to fit them to the mating parts.
- Assemble the adhesive-applied parts within ten minutes.
- Apply a liquid gasket (Three Bond 1217D) to the gear case cover.

Tightening torque	Gear case cover mounting screw	23.5 to 27.5 N-m 2.4 to 2.8 kgf-m 17.4 to 20.3 ft-lbs
-------------------	--------------------------------	---

(1) Liquid Gasket

W1189218

#### Relief Valve

1. Remove the relief valve retaining screw (1).
2. Remove the relief valve (2), the spring (3) and the packing (4).

Tightening torque	Relief valve retaining screw	68.6 to 78.4 N-m 7.0 to 8.0 kgf-m 50.6 to 57.9 ft-lbs
-------------------	------------------------------	---

- (1) Relief Valve Retaining Screw      (3) Spring  
(2) Relief Valve      (4) Packing

W1081251

#### Idle Gear and Camshaft

1. Remove three set screws of the idle gear and draw out the idle gear 1, 2.
2. Remove two set screws of the camshaft stopper and draw out the camshaft.

#### (When reassembling)

- Set the crankshaft at the top dead center of No. 1 and 4 cylinder and the camshaft key to the top position and align the marks of idle gear 1 (3) and idle gear 2 (2) to assemble them. (Refer to the figure on the left.)
- Mount the injection pump gear (1) after installing the gear case.

Tightening torque	Camshaft set screw	23.5 to 27.5 N-m 2.4 to 2.8 kgf-m 17.4 to 20.3 ft-lbs
	Idle gear mounting screw	23.5 to 27.5 N-m 2.4 to 2.8 kgf-m 17.4 to 20.3 ft-lbs

- (1) Injection Pump Gear      (4) Cam Gear  
(2) Idle Gear 2      (5) Crank Gear  
(3) Idle Gear 1

W1189797

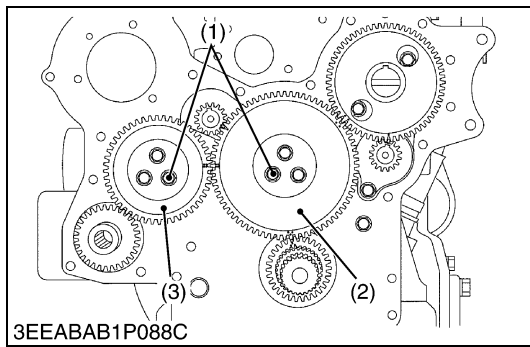

**Idle Gear 1 and Idle Gear 2 (for Balancer Model)**

1. Remove the idle gear mounting screw (1).
2. Draw out the idle gear (2) and (3).

**(When reassembling)**

- When install the idle gear (2) and (3), be sure to place the 4th cylinder piston at the top dead center in compressio then, align all mating marks on each gear to assemble the timing gears, set the idle gear last.

Tightening torque	Idle gear mounting screw	23.5 to 27.5 N·m 2.4 to 2.8 kgf·m 17.4 to 20.3 ft·lbs
-------------------	--------------------------	---

- (1) Idle Gear Mounting Screw (3) Idle Gear 2  
(2) Idle Gear 1

W1032991

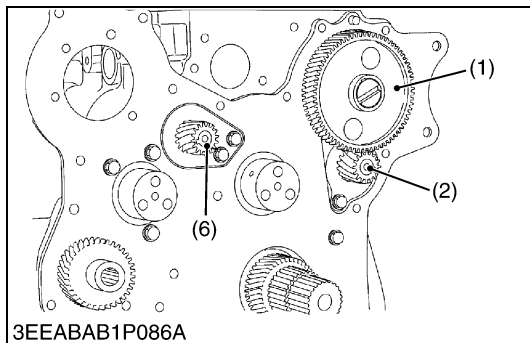

**Camshaft and Balancer Shaft (for Balancer Model)**

1. Remove the camshaft set screws and draw out the camshaft (1).
2. Remove the balancer shaft 1 set screws and draw out the balancer shaft 1 (2).
3. Remove the balancer shaft 2 set screws and draw out the balancer shaft 2 (6).

**(When reassembling)**

- When install the balancer shaft 1 and 2, be sure to place the 4th cylinders piston at the top dead center in compression then, align all mating marks on each gear to assemble the timing gears, set the idle gear last.

Tightening torque	Camshaft set screw	23.5 to 27.5 N·m 2.4 to 2.8 kgf·m 17.4 to 20.3 ft·lbs
	Balancer shaft set screw	23.5 to 27.5 N·m 2.4 to 2.8 kgf·m 17.4 to 20.3 ft·lbs

- (1) Camshaft (4) Crank Gear  
(2) Balancer Shaft 1 (5) Idle Gear 2  
(3) Idle Gear 1 (6) Balancer Shaft 2

W1191037

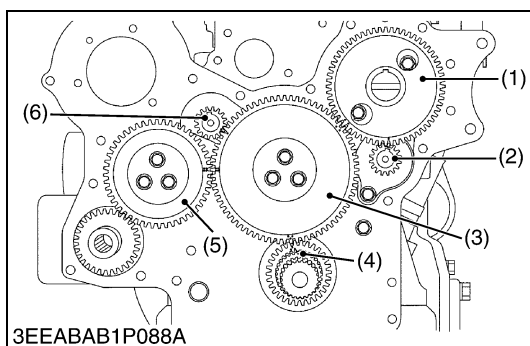
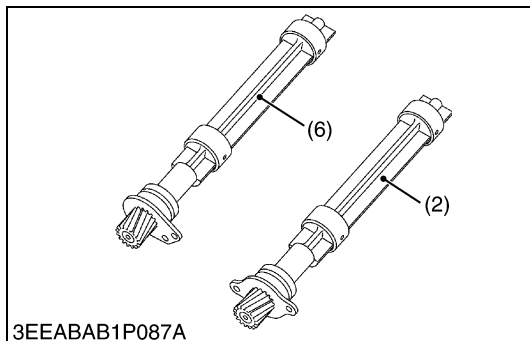

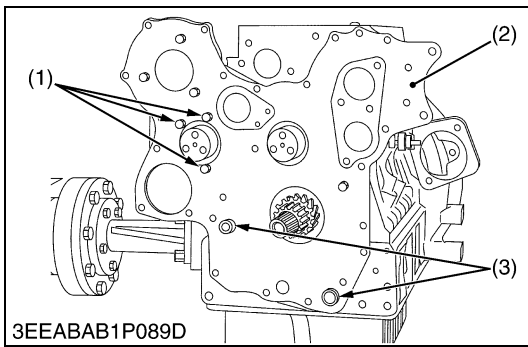

**Plate (Gear Case)**

1. Remove the three plate mounting screws (1). Detach the plate (2).

**(When reassembling)**

- Apply Three Bond 1217D adhesive or equivalent over the shaded zones on both sides of the gasket that will be sandwiched between the crankcase and plate.
- Be sure to fix the O-rings (3).

Tightening torque	Plate mounting screw	23.5 to 27.5 N-m 2.4 to 2.8 kgf-m 17.4 to 20.3 ft-lbs
-------------------	----------------------	---

- (1) Plate Mounting Screw
- (2) Plate
- (3) O-ring
- (4) Gasket
- (5) Liquid Gasket

W1057656

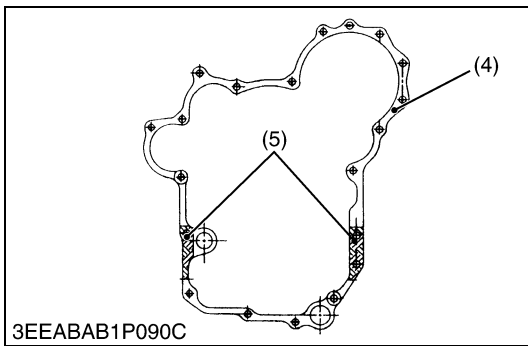

**(9) Piston and Connecting Rod**

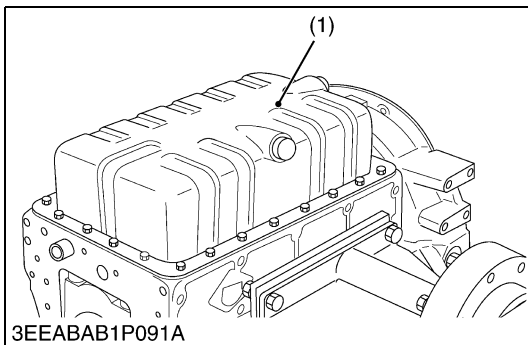

**Oil Pan and Oil Strainer**

1. Unscrew the oil pan mounting screws and remove the oil pan (1).
2. Unscrew the oil strainer mounting screw, and remove the oil strainer (2).

**(When reassembling)**

- Install the oil strainer, using care not to damage the O-ring.
- Apply liquid gasket (Three Bond 1217D) to the oil pan as shown in the figure.
- Confirm that the liquid gasket coating surface is free of water, dust and oil in order to maintain sealing effect.
- Carefully apply the adhesive evenly.

**NOTE**

- When mounting the adhesive-applied parts, take care to fit them to the mating parts.
- Assemble the adhesive-applied parts within ten minutes.
- To avoid uneven tightening, tighten mounting screws in diagonal order from the center.
- After cleaning the oil strainer, install it.
- Attach the oil pan with its central drain plug facing toward the air suction side.

- (1) Oil Pan
- (2) Oil Strainer
- (3) Liquid Gasket

W1057949

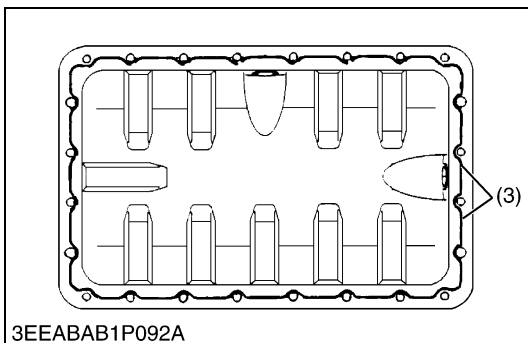
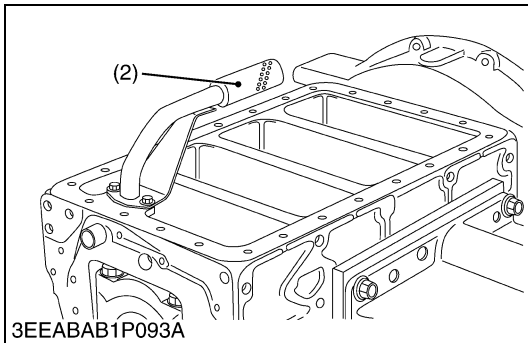

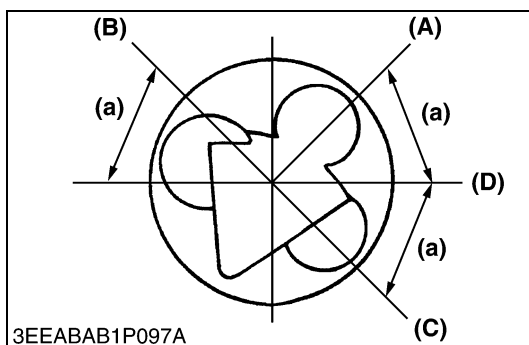
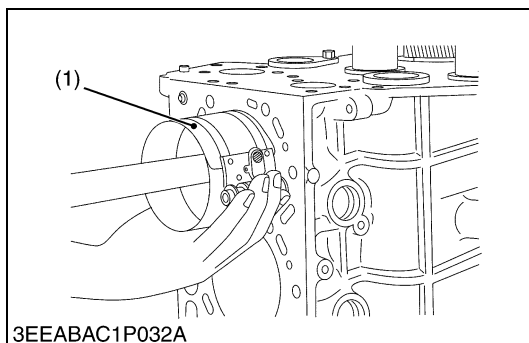
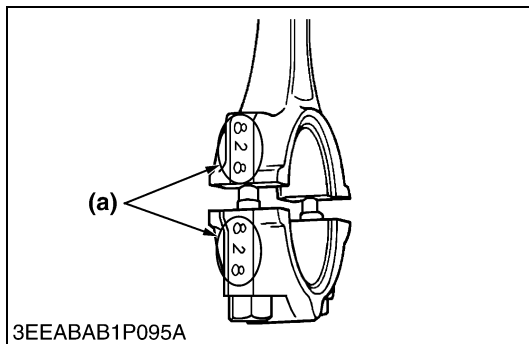
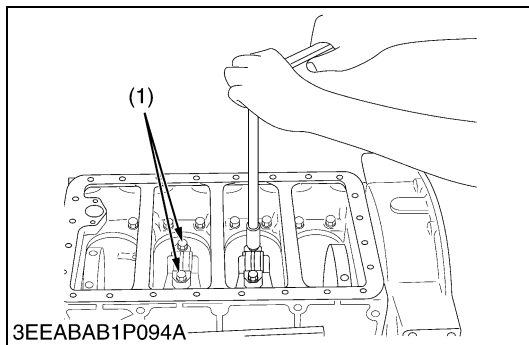

### Connecting Rod Cap

1. Remove the connecting rod screws (1) from connecting rod cap.
2. Remove the connecting rod caps.

#### (When reassembling)

- Align the marks (a) with each other. (Face the marks toward the injection pump.)
- Apply engine oil to the connecting rod screws and lightly screw it in by hand, then tighten it to the specified torque.  
If the connecting rod screw won't be screwed in smoothly, clean the threads.  
If the connecting rod screw is still hard to screw in, replace it.
- When using the existing crank pin metal again, put tally marks on the crank pin metal and the connecting rod in order to keep their positioning.
- Fit the crank pin metal in place : its centrally groove side toward the connecting rod, and the non-grooved side toward the cap.

Tightening torque	Connecting rod screw	78.5 to 83.4 N·m 8.0 to 8.5 kgf·m 57.9 to 61.5 ft·lbs

(1) Connecting Rod Screw

(a) Mark

W1058252

### Piston

1. Turn the flywheel and set a piston to the top dead center.
2. Pull out the piston upward by lightly tapping it from the bottom of the crankcase with the grip of a hammer.

#### (When reassembling)

- Before inserting the piston into the cylinder, apply enough engine oil to the cylinder.
- When inserting the piston into the cylinder, face the mark on the connecting rod to the injection pump.

#### ■ IMPORTANT

- **Do not change the combination of cylinder and piston.**  
**Make sure of the position of each piston by marking.** For example, mark "1" on the No. 1 position.
- **When inserting the piston into the cylinder, place the gap of the top ring on the opposite side of the combustion chamber and stagger the gaps of the second ring and oil ring marking a right angle from the gap of the top ring.**
- **Carefully insert the pistons using a piston ring compressor (1).** Otherwise, their chrome-plated section may be scratched, causing trouble inside the liner.

(1) Piston Ring Compressor

(A) Top Ring Gap

(B) Second Ring Gap

(C) Oil Ring Gap

(D) Piston Pin Hole

(a) 0.79 rad (45 °)

W1058433



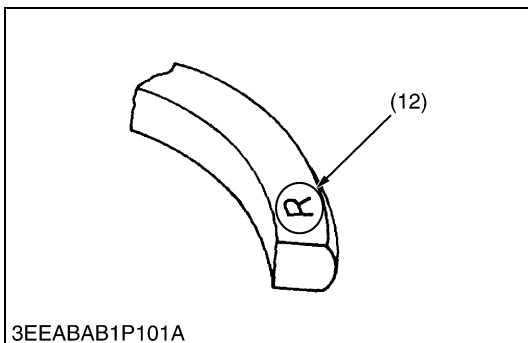
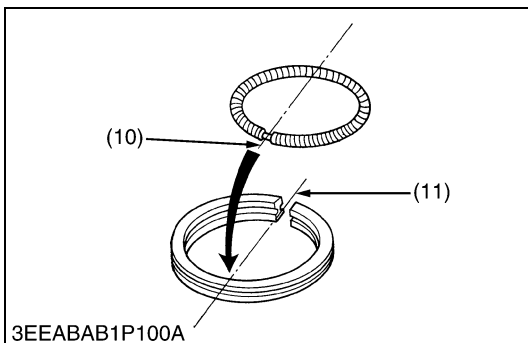
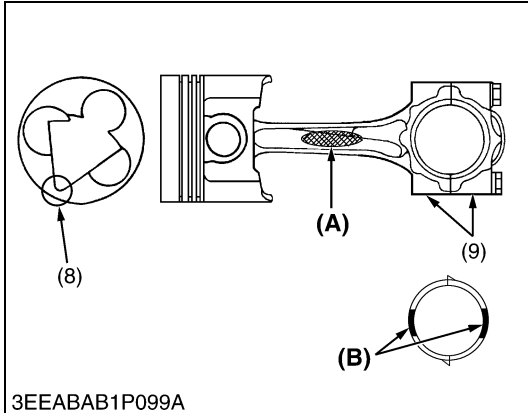
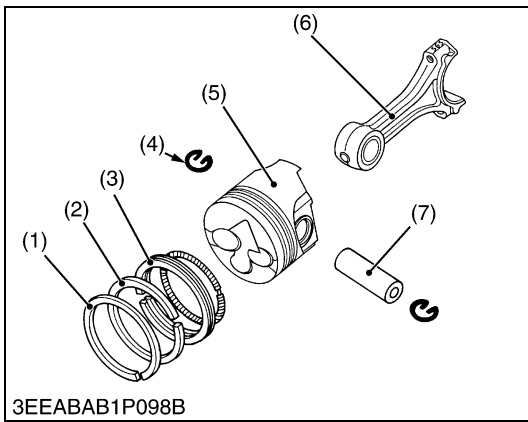

### Piston Ring and Connecting Rod

1. Remove the piston rings using a piston ring tool.
2. Put the fan shaped concave (8) on the piston as shown in figure.
3. Remove the piston pin (7), and separate the connecting rod (6) from the piston (5).

#### (When reassembling)

- Be sure to fix the crankpin bearing and the connecting rod are same I.D. colors.
- When installing the ring, assemble the rings so that the manufacture's mark (12) near the gap faces the top of the piston.
- When installing the oil ring onto the piston, place the expander joint (10) on the opposite side of the oil ring gap (11).
- Apply engine oil to the piston pin.
- When installing the piston pin, immerse the piston in 80 °C (176 °F) oil for 10 to 15 minutes and insert the piston pin to the piston.
- Assemble the piston to the connecting rod with the aligning the direction of the fan shaped concave (8) of piston head and the mark (9) of connecting rod.
- The end faces of the oil ring are plated with hard chrome. In putting the piston into the cylinder, be careful not to get the oil ring scratched by the cylinder. Use the piston ring fitter to tighten up the oil ring. If the ring's planting is scratched, it may get stuck on the cylinder wall, causing a serious trouble.

#### ■ IMPORTANT

- **Mark the same number on the connecting rod and the piston so as not to change the combination.**

- |                          |   |
|--------------------------|---|
| (1) Top Ring             | (11) Oil Ring Gap   |
| (2) Second Ring          | (12) Manufacture's Mark   |
| (3) Oil Ring             |   |
| (4) Piston Pin Snap Ring | <b>(A) Connecting Rod ID Color : Blue or Yellow (without Color)</b>   |
| (5) Piston               | <b>(B) Crankpin Bearing ID Color : Blue or Yellow (without Color)</b> |
| (6) Connecting Rod       |   |
| (7) Piston Pin           |   |
| (8) Fan Shaped Concave   |   |
| (9) Mark                 |   |
| (10) Expander Joint      |   |

W1059589

## (10) Flywheel and Crankshaft

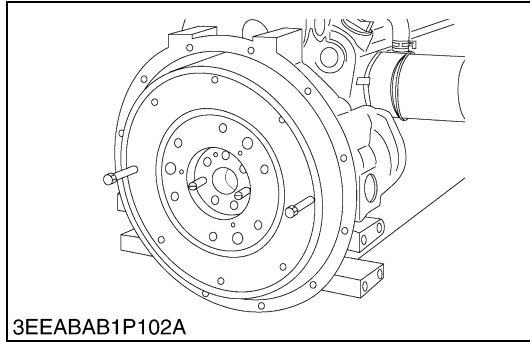

### Flywheel

1. Install the stopper to the flywheel so that the flywheel does not turn.

#### ■ NOTE

- **Do not use an impact wrench. Serious damage will occur.**
2. Detach the flywheel screws.
  3. Remove the flywheel.

#### (When reassembling)

- Apply engine oil to the flywheel screws.
- Before fitting the flywheel and the crankshaft together, wipe oil, dust and other foreign substances off their mating faces.
- The flywheel and the crankshaft are fitting together in just one position. Make sure they are tightly fit and drive the bolts.

Tightening torque	Flywheel screw	98.1 to 107.9 N·m 10.0 to 11.0 kgf·m 72.3 to 79.6 ft-lbs
-------------------	----------------	--

W1060354

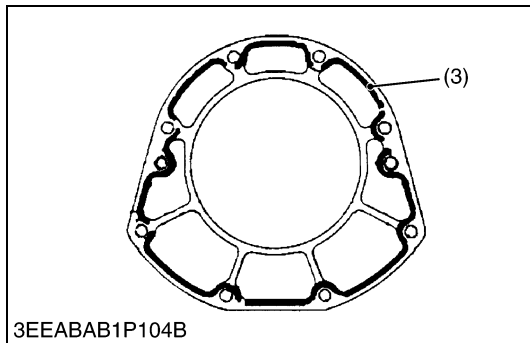
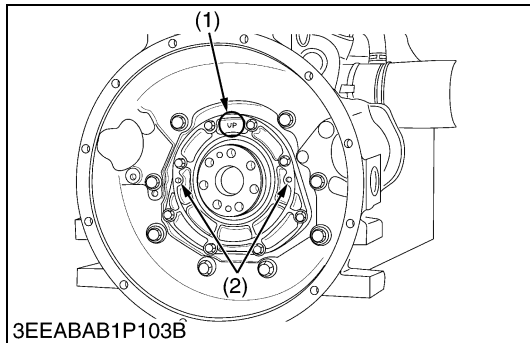

### Bearing Case Cover

#### ■ NOTE

- **Before disassembling, check the side clearance of crankshaft. Also check it during reassembly.**

1. Remove the bearing case over mounting screws.
2. Screw two removed screws into the screw hole (2) of bearing case cover to remove it.

#### (When reassembling)

#### ■ IMPORTANT

- In case of replacing the oil seal, use caution when installing the seal in the bearing case cover as not to install it tilted. The seal should be flush with the cover.
- Confirm that the liquid gasket coating surface is free of water, dust and oil in order to maintain sealing effect.
- Apply liquid gasket (Three Bond 1217D) to the bearing case cover as shown in the figure.
- Before installing the bearing case cover / oil seal assembly, lube the seal and be careful not to damage the seal while installing the assembly. Install the bearing case cover / oil seal assembly to position the casting mark "UP" on it upward.
- Tighten the bearing case cover mounting screws with even force on the diagonal line.

#### ■ NOTE

- When mounting the adhesive-applied parts, take care to fit them to the mating parts.
- Assemble the adhesive-applied parts within ten minutes.

Tightening torque	Bearing case cover mounting screw	23.5 to 27.5 N·m 2.4 to 2.8 kgf·m 17.4 to 20.3 ft-lbs
-------------------	-----------------------------------	---

- (1) Top Mark "UP"  
(2) Screw Hole

- (3) Liquid Gasket

W1060482

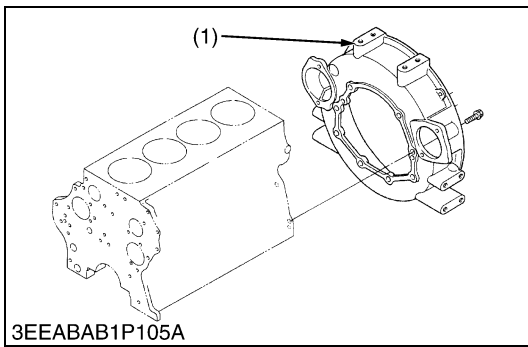

**Flywheel Housing**

1. Remove the flywheel housing.

**(When reassembling)**

- Tighten the flywheel housing mounting screws with even force on the diagonal line.
- Make sure the crank cases 1 and 2 are clean. Install them in position, referring to the flywheel housing's contoured face.

Tightening torque	Flywheel housing mounting screw	77.5 to 90.2 N-m 7.9 to 9.2 kgf-m 57.1 to 66.5 ft-lbs
-------------------	---------------------------------	---

(1) Flywheel Housing

W1060705

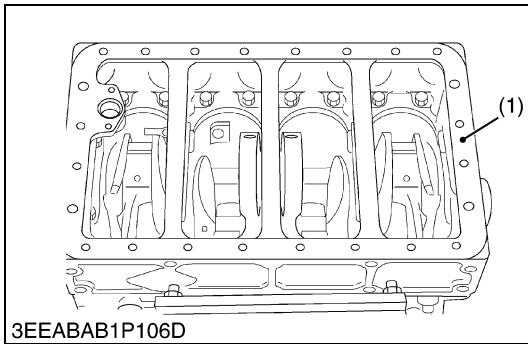

**Crankcase 2**

1. Remove the crankcase 2 (1).

**(When reassembling)**

■ **IMPORTANT**

- Make sure the crankcase 1 and 2 are clean.
- Apply liquid gasket (Three Bond 1217D) to the crankcase 2 as shown in the figure.
- Tighten the crankcase 2 mounting screws with even force on the diagonal line.
- Confirm that the liquid gasket coating surface is free of water, dust and oil in order to maintain sealing effect.
- Carefully apply the adhesive evenly.

■ **NOTE**

- When mounting the adhesive-applied parts, take care to fit them to the mating parts.
- Assemble the adhesive-applied parts within ten minutes.

Tightening torque	Crankcase 2 mounting screw	49.0 to 55.9 N-m 5.0 to 5.7 kgf-m 36.2 to 41.2 ft-lbs
-------------------	----------------------------	---

(1) Crankcase 2

(2) Liquid Gasket

W1060825

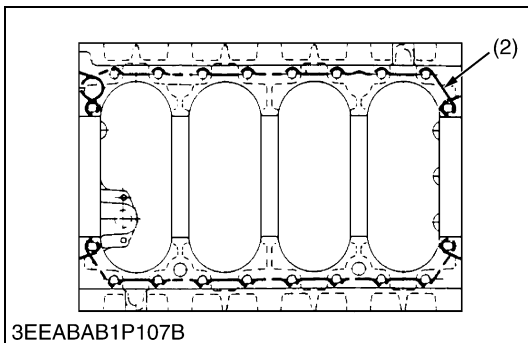

**Crankcase 1 and Crankcase 2**

**(When reassembling)**

- Match the crankcase 1 and 2, referring to the flywheel housing's contoured face.
- Tighten the crankcase 2 mounting screws loosely.
- Tighten up the jig to the specified torque same as the flywheel housing screw. This helps to minimize the level difference between the crankcase 1 and the crankcase 2 (at the flywheel side). Possible gap must be 0.05 mm (0.0020 in.) or smaller.

Tightening torque	Crankcase 2 mounting screw	49.0 to 55.9 N-m 5.0 to 5.7 kgf-m 36.2 to 41.2 ft-lbs
	Flywheel housing mounting screw	77.5 to 90.2 N-m 7.9 to 9.2 kgf-m 57.1 to 66.5 ft-lbs

(1) Crankcase 1

(4) Crankcase 2

(2) Gap to be smaller than 0.05 mm (0.0020 in.)

(5) Jig

(3) Flywheel Housing

W1111351

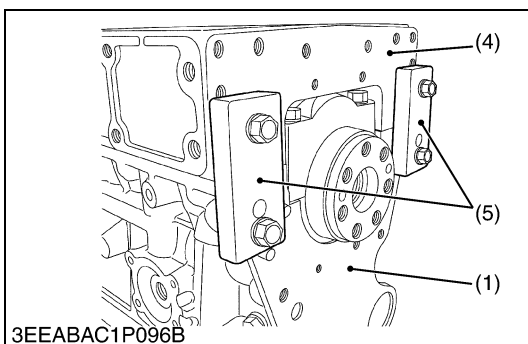
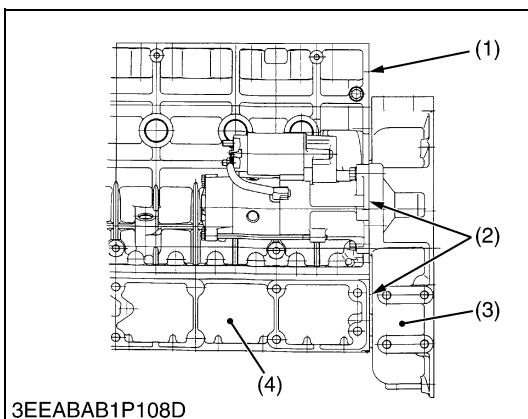



**(11) Starter**

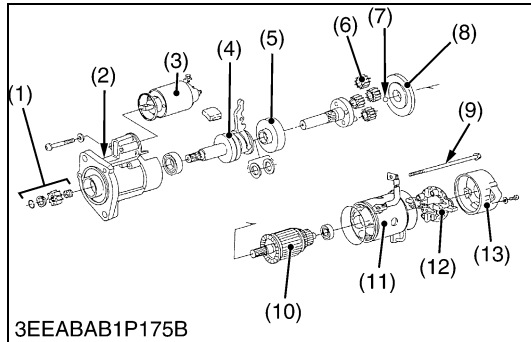

**Disassembling Motor**

1. Disconnect the solenoid switch (3).
2. Remove the 2 through screws (9) and the 2 brush holder lock screws. Take out the rear end frame (13) and the brush holder (12).
3. Disconnect the armature (10) and the yoke (11). Remove also the ball (7) from the tip of the armature.
4. Remove the set of packings (8), the 4 planetary gears and another packing.
5. Take out the shaft assembly. Take note of the position of the lever.

**IMPORTANT**

- Before disconnecting the yoke, put tally marks on the yoke and the front bracket.
- Take note of the positions of the set of packings and the setup bolt.
- Apply grease to the gears, bearings, shaft's sliding part and ball.

**NOTE**

- Do not damage to the brush and commutator.

**(When reassembling)**

- Apply grease (DENSO CO. No.50 or equivalent) to the parts indicated in the figure.

- |                        |                     |
|------------------------|---------------------|
| (1) Gear               | (8) Set of Packings |
| (2) Front Bracket      | (9) Through Bolt    |
| (3) Solenoid Switch    | (10) Armature       |
| (4) Overrunning Clutch | (11) Yoke           |
| (5) Internal Gear      | (12) Brush Holder   |
| (6) Planetary Gear     | (13) Rear End Frame |
| (7) Ball               |                     |

W1074237

**(12) Alternator**

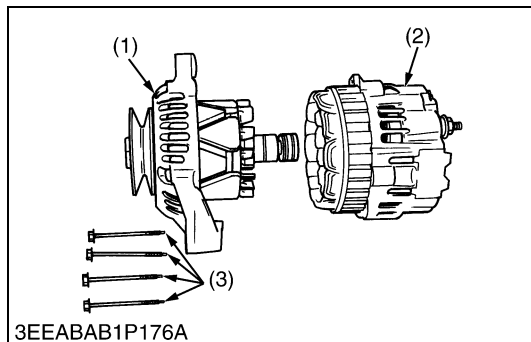

**Front Bracket**

1. Remove the 4 screws (3).
2. Separate the front bracket (1) and the rear bracket (2) from each other.

**IMPORTANT**

- Put a tally line on the front bracket and the rear bracket for reassembling them later.

- |                   |           |
|-------------------|-----------|
| (1) Front Bracket | (3) Screw |
| (2) Rear Bracket  |           |

W1074745

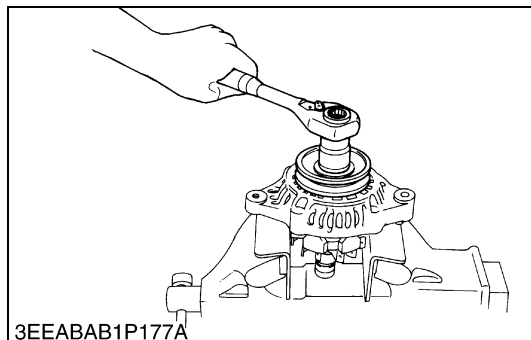

**Pulley**

1. Hold the rotor (base of the claw) in a vise. Loosen the lock nut using a M24 box wrench.

Tightening torque	Pulley nut	58.3 to 78.9 N-m 5.95 to 8.05 kgf-m 43.0 to 58.2 ft-lbs
-------------------	------------	---

W1074849

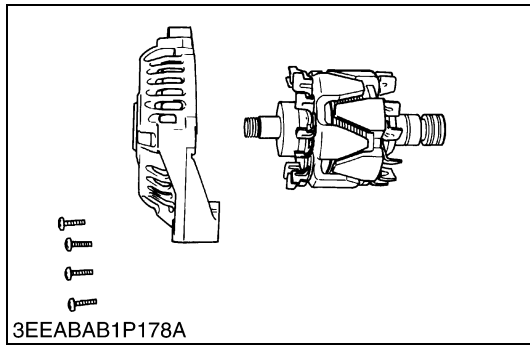
**Rotor**

1. Remove the 4 screws and detach the bearing retainer.
2. Temporarily install the nut on the pulley screw, and detach the rotor.

W1074920

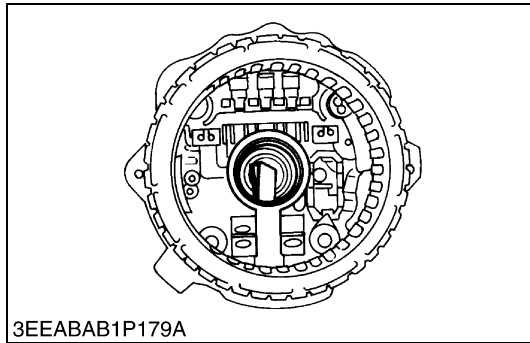
**Brush**

1. When the rotor is detached, the 2 brushes are found to stretch out of the shaft hole.

W1075045

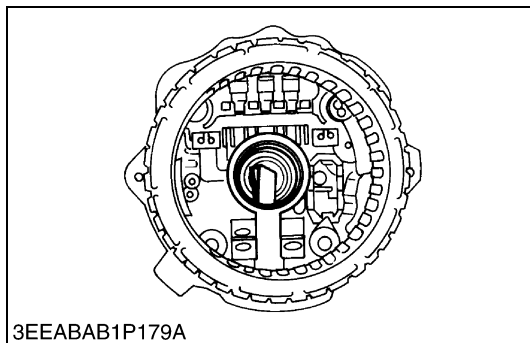
**Reassembling the Brush**

1. Fit the brush with its sliding face in the clockwise direction when viewed from front.

**■ IMPORTANT**

- Be sure to keep the 2 brushes deep in the brush holder. Otherwise the rotor and the rear section can not be fitted into the position.
  - Use a 4 mm hex. wrench to push the brushes into place.
  - Using a pin-pointed (2 mm) punch, keep the brushes from popping out.
2. Match the tally line of the front section with that of the rear section.
  3. Tighten the 4 screws, and draw out the pin-pointed punch out of the brush holder.

(1) Marking

W1075117

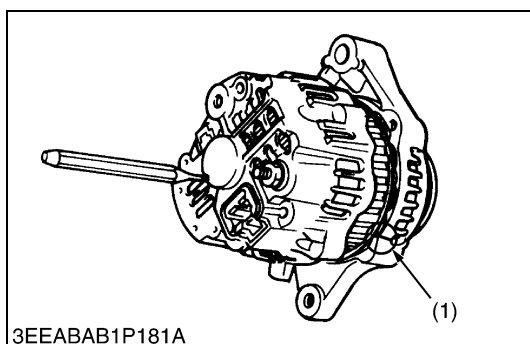
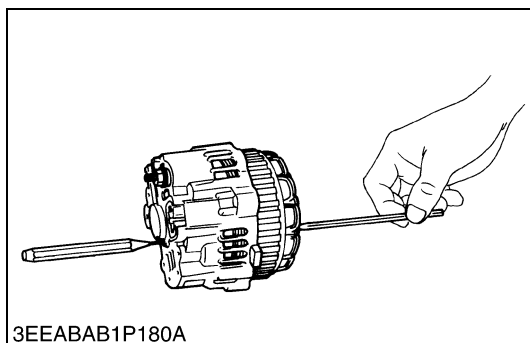

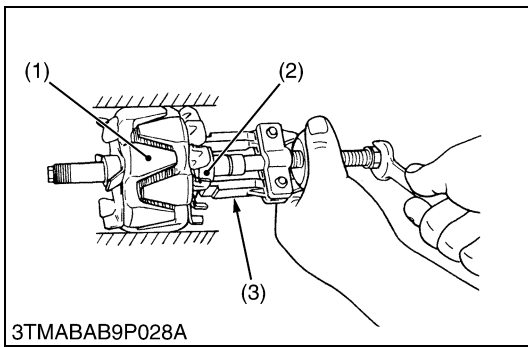

**Bearing at Slip Ring Side**

1. Lightly secure the rotor (1) with a vise to prevent damage, and remove the bearing (2) with a puller (3).

- (1) Rotor
- (2) Bearing
- (3) Puller

W1019701

**[3] SERVICING**

**(1) Cylinder Head**

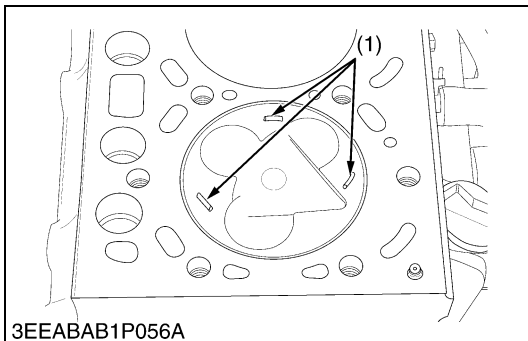

**Top Clearance**

1. Remove the cylinder head (remove the cylinder head gasket completely).
2. Bring the piston to its top dead center fasten 1.5 mm dia. 5 to 7 mm long fuse wires to 3 to 4 spots on the piston top with grease so as to avoid the intake and exhaust valves and the combustion chamber ports.
3. Bring the piston to its middle position, install the cylinder head, and tighten the cylinder head screws to specification. (Head gasket must be changed to new one).
4. Turn the crankshaft until the piston exceeds its top dead center.
5. Remove the cylinder head, and measure squeezed fuse wires for thickness.
6. If the measurement is not within the specified value, check the oil clearance of the crankpin journal and the piston pin.

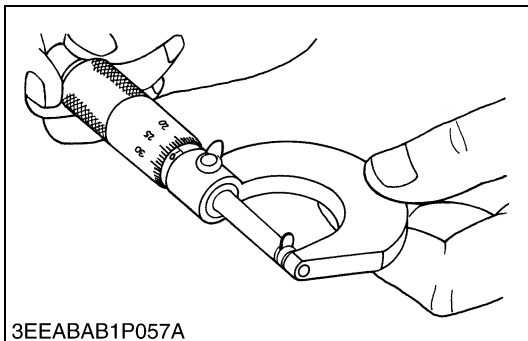

Top clearance	Factory spec.	V3300-E2B	0.72 to 0.90 mm 0.0283 to 0.0354 in.
		V3300-T-E2B	0.92 to 1.10 mm 0.0362 to 0.0433 in.

Tightening torque	Cylinder head mounting screw	98.1 to 107.9 N-m 10.0 to 11.0 kgf-m 72.3 to 79.6 ft-lbs
-------------------	------------------------------	--

- (1) Fuse

W1049122

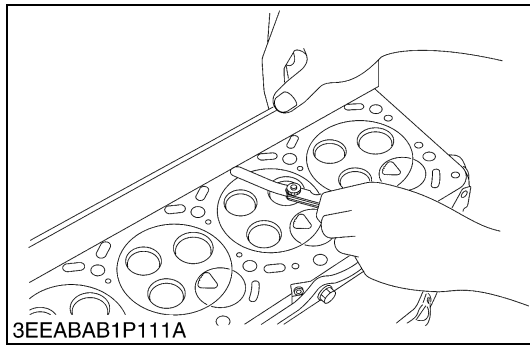

**Cylinder Head Surface Flatness**

1. Clean the cylinder head surface.
2. Place a straightedge on the cylinder head's four sides (A), (B), (C) and (D) and two diagonal (E) and (F) as shown in the figure. Measure the clearance with a feeler gauge.
3. If the measurement exceeds the allowable limit, correct it with a surface grinder.

**IMPORTANT**

- Do not place the straight edge on the combustion chamber.
- Be sure to check the valve recessing after correcting.

Cylinder head surface flatness	Allowable limit	0.05 mm 0.0020 in.
--------------------------------	-----------------	-----------------------

W1061323

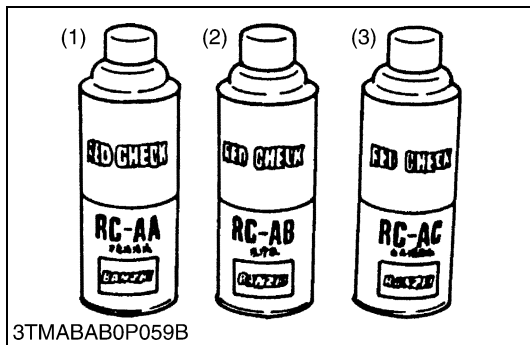
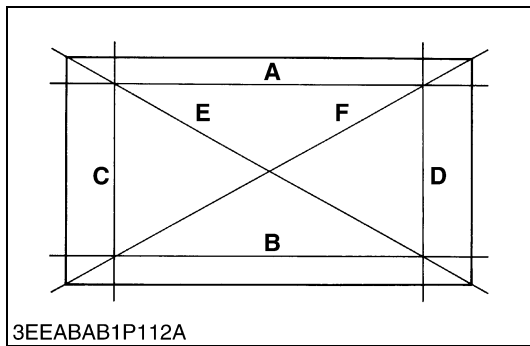

**Cylinder Head Flaw**

1. Prepare an air spray red check.
2. Clean the surface of the cylinder head with detergent (2).
3. Spray the cylinder head surface with the red permeative liquid (1). Leave it five to ten minutes after spraying.
4. Wash away the red permeative liquid on the cylinder head surface with the detergent (2).
5. Spray the cylinder head surface with white developer (3).
6. If flawed, it can be identified as red marks.

- (1) Red Permeative Liquid                      (3) White Developer  
 (2) Detergent

W1076542



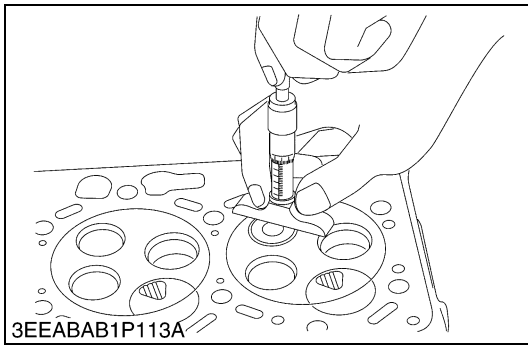

**Valve Recessing**

1. Clean the cylinder head, the valve face and seat.
2. Insert the valve into the valve guide.
3. Measure the valve recessing with a depth gauge.
4. If the measurement exceeds the allowable limit, replace the valve.

If it still exceeds the allowable limit after replacing the valve, replace the cylinder head.

Valve recessing	Factory spec.	Intake valve	(Protrusion) 0 mm (0 in.) to (recessing) 0.2 mm (0.0079 in.)
		Exhaust valve	(Protrusion) 0.15 mm (0.0059 in.) to (recessing) 0.05 mm (0.0019 in.)
	Allowable limit	(recessing)	0.4 mm (0.0157 in.)

(1) Cylinder Head Surface

**(A) Recessing**  
**(B) Protrusion**

W1061543

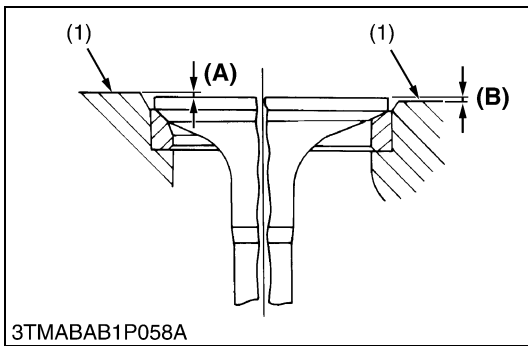

**Valve Lapping**

1. Apply compound evenly to the valve lapping surface.
2. Insert the valve into the valve guide. Lap the valve onto its seat with a valve flapper or screwdriver.
3. After lapping the valve, wash the compound away and apply oil, then repeat valve lapping with oil.
4. Apply prussian blue to the contact surface to check the seated rate. If it is less than 70 %, repeat valve lapping again.

**IMPORTANT**

- When valve lapping is performed, be sure to check the valve recessing and adjust the valve clearance after assembling the valve.

(1) Correct  
(2) Incorrect

(3) Incorrect

W1061709

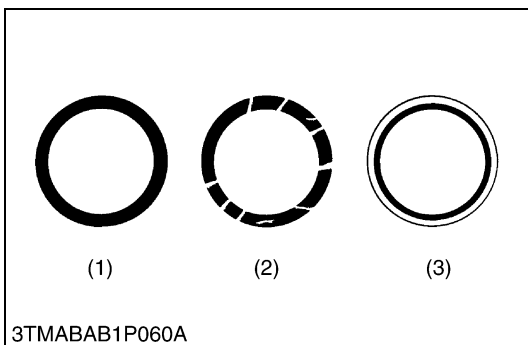
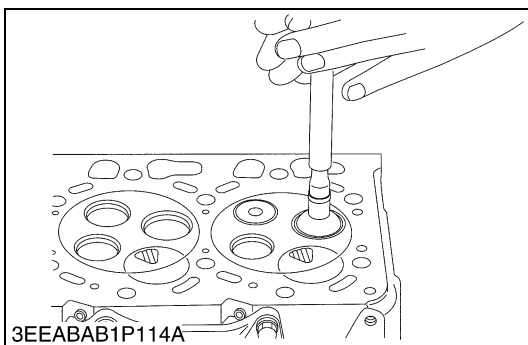

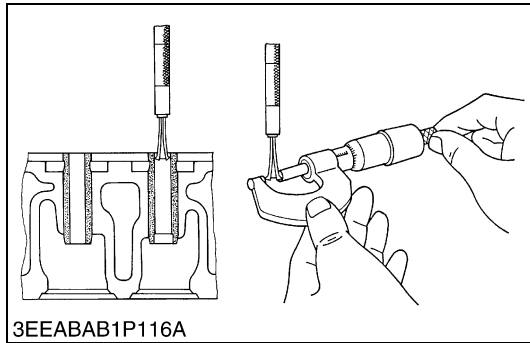
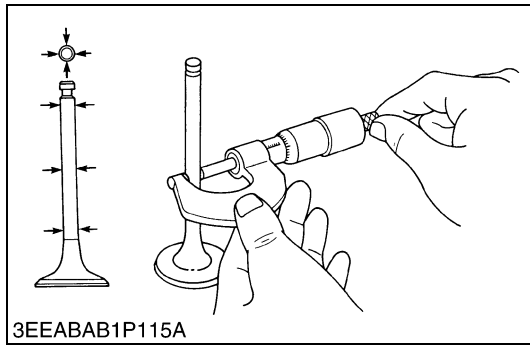

### **Clearance between Valve Stem and Valve Guide**

1. Remove carbon from the valve guide section.
2. Measure the valve stem O.D. with an outside micrometer.
3. Measure the valve guide I.D. of the cylinder head at the most wear part as shown in the figure below with a small hole gauge. And calculate the clearance.
4. If the clearance exceeds the allowable limit, replace the valves. If it still exceeds the allowable limit, replace the valve guide.

Clearance between valve stem and guide	Factory spec.	Intake valve	0.055 to 0.085 mm 0.0022 to 0.0033 in.
		Exhaust valve	0.040 to 0.070 mm 0.0016 to 0.0028 in.
	Allowable limit		0.1 mm 0.0039 in.

Valve stem O.D.	Factory spec.	Intake valve	6.960 to 6.975 mm 0.2740 to 0.2746 in.
		Exhaust valve	7.960 to 7.975 mm 0.3134 to 0.3140 in.

Valve guide I.D.	Factory spec.	Intake valve	7.030 to 7.045 mm 0.2768 to 0.2774 in.
		Exhaust valve	8.015 to 8.030 mm 0.3155 to 0.3161 in.

W1061883

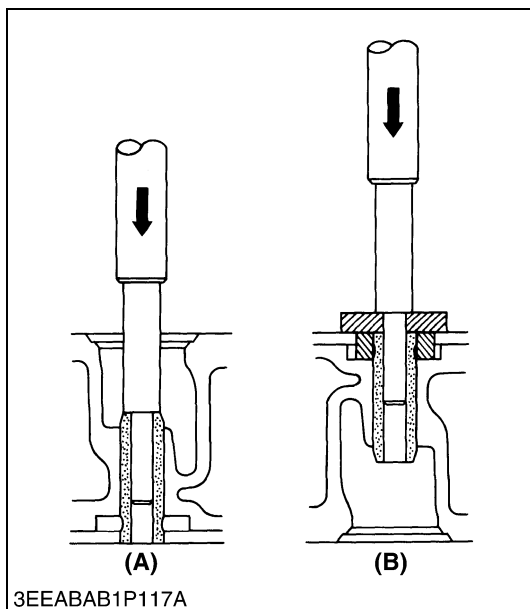

### **Replacing Valve Guide**

#### **(When removing)**

1. Using a valve guide replacing tool, press out the used valve guide.

#### **(When installing)**

1. Clean a new valve guide, and apply engine oil to it.
2. Using a valve guide replacing tool, press in a new valve guide until it is flush with the cylinder head as shown in the figure.
3. Ream precisely the I.D. of the valve guide to the specified dimension.

#### **■ IMPORTANT**

- Do not hit the valve guide with a hammer, etc. during replacement.

(A) When Removing

(B) When Installing

W1062212

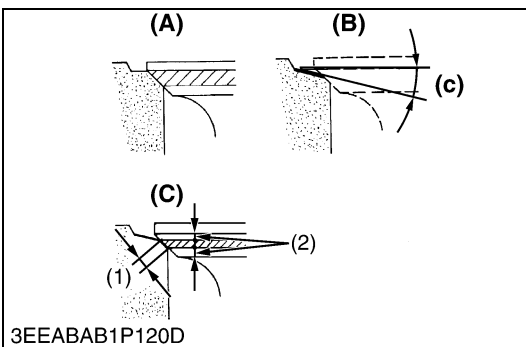
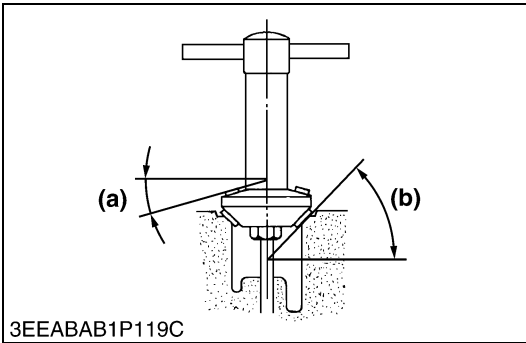
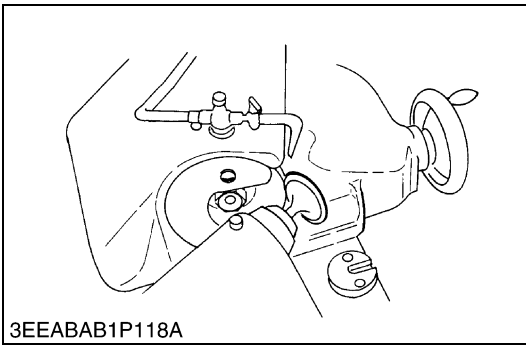

## Correcting Valve and Valve Seat

### ■ NOTE

- Before correcting the valve and seat, check the valve stem and the I.D. of valve guide section, and repair them if necessary.
- After correcting the valve seat, be sure to check the valve recessing.

### 1) Correcting Valve

1. Correct the valve with a valve refacer.

Valve face angle	Factory spec.	IN.	1.047 rad 60 °
		EX.	0.785 rad 45 °

### 2) Correcting Valve Seat

1. Slightly correct the seat surface with a 1.047 rad (60 °) (intake valve) or 0.785 rad (45 °) (exhaust valve) valve seat cutter.
2. Resurface the seat surface with a 0.523 rad (30 °) valve seat cutter to intake valve seat and with a 0.262 rad (15 °) valve seat cutter to exhaust valve seat so that the width is close to specified valve seat width. (2.12 mm, 0.0835 in.)
3. After resurfacing the seat, inspect for even valve seating, apply a thin film of compound between the valve face and valve seat, and fit them with valve lapping tool.
4. Check the valve seating with prussian blue. The valve seating surface should show good contact all the way around.

Valve seat angle	Factory spec.	IN.	1.047 rad 60 °
		EX.	0.785 rad 45 °

- (1) Valve Seat Width  
(2) Identical Dimensions

- (A) Check Contact  
(B) Correct Seat Width  
(C) Check Contact  
(a) 0.262 rad (15 °) or 0.523 rad (30 °)  
(b) 0.785 rad (45 °) or 1.047 rad (60 °)  
(c) 0.523 rad (30 °) or 0.262 rad (15 °)

W10283500

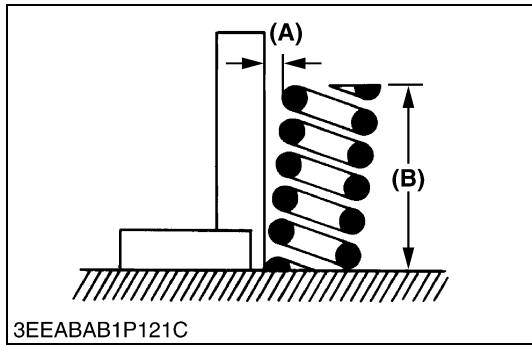

**Free Length and Tilt of Valve Spring**

1. Measure the free length (B) with vernier calipers. If the measurement is less than the allowable limit, replace it.
2. Put the spring on a surface plate, place a square on the side of the spring, and check to see if the entire side is contact with the square. Rotate the spring and measure the maximum (A). If the measurement exceeds the allowable limit, replace.
3. Check the entire surface of the spring for scratches. Replace it, if any.

Tilt (A)	Allowable limit	1.0 mm 0.039 in.
----------	-----------------	---------------------

Free length (B)	Factory spec.	Intake valve	35.1 to 35.6 mm 1.3819 to 1.4016 in.
		Exhaust valve	41.7 to 42.2 mm 1.6417 to 1.6614 in.
	Allowable limit	Intake valve	34.6 mm 1.3622 in.
		Exhaust valve	41.2 mm 1.6220 in.

(A) Tilt

(B) Free length

W1063303

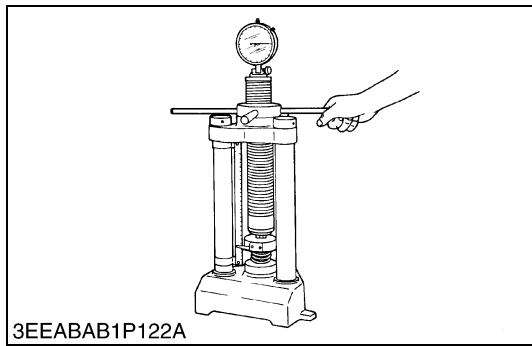

**Valve Spring Setting Load**

1. Place the valve spring on a tester and compress it to the same length it is actually compressed in the engine.
2. Read the compression load on the gauge.
3. If the measurement is less than the allowable limit, replace it.

Setting load / setting length	Factory spec.	Intake valve	63.547 N / 31.5 mm 6.48 kgf / 31.5 mm 14.256 lbs / 1.2401 in.
		Exhaust valve	117.6 N / 35 mm 12.0 kgf / 35 mm 26.4 lbs / 1.3780 in.
	Allowable limit	Intake valve	45.864 N / 31.5 mm 4.68 kgf / 31.5 mm 10.296 lbs / 1.2401 in.
		Exhaust valve	100 N / 35 mm 10.2 kgf / 35 mm 22.5 lbs / 1.3780 in.

W1063470

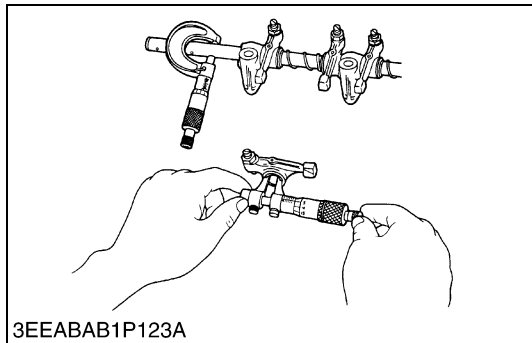

**Oil Clearance between Rocker Arm Shaft and Bearing**

1. Measure the rocker arm bearing I.D. with an inside micrometer.
2. Measure the rocker arm shaft O.D. with an outside micrometer, and then calculate the oil clearance.
3. If the clearance exceeds the allowable limit, replace the rocker arm and measure the oil clearance again. If it still exceeds the allowable limit, replace also the rocker arm shaft.

Oil clearance of rocker arm shaft and bearing	Factory spec.	0.016 to 0.045 mm 0.0006 to 0.0018 in.
	Allowable limit	0.15 mm 0.0059 in.

Rocker arm shaft O.D.	Factory spec.	15.973 to 15.984 mm 0.6289 to 0.6293 in.
Rocker arm I.D. for shaft	Factory spec.	16.000 to 16.018 mm 0.6299 to 0.6306 in.

W1063697

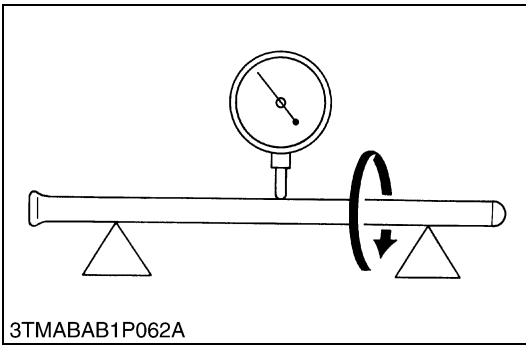

### Push Rod Alignment

1. Place the push rod on V blocks.
2. Measure the push rod alignment.
3. If the measurement exceeds the allowable limit, replace the push rod.

Push rod alignment	Allowable limit	0.25 mm 0.0098 in.
--------------------	-----------------	-----------------------

W10292900

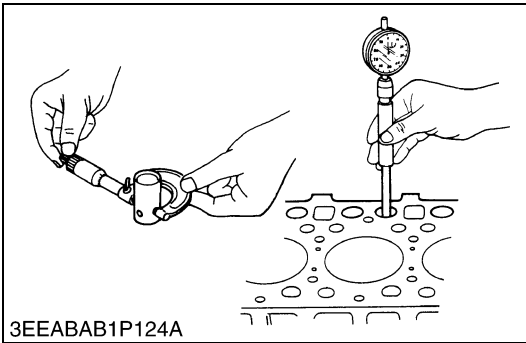

### Oil Clearance between Tappet and Tappet Guide Bore

1. Measure the tappet O.D. with an outside micrometer.
2. Measure the I.D. of the tappet guide bore with a cylinder gauge, and calculate the oil clearance.
3. If the oil clearance exceeds the allowable limit or the tappet is damaged, replace the tappet.

Oil clearance between tappet and guide bore	Factory spec.	0.020 to 0.062 mm 0.0008 to 0.0024 in.
	Allowable limit	0.07 mm 0.0028 in.

Tappet O.D.	Factory spec.	23.959 to 23.980 mm 0.9433 to 0.9441 in.
Tappet guide bore I.D.	Factory spec.	24.000 to 24.021 mm 0.9449 to 0.9457 in.

W1063847

## (2) Timing Gears

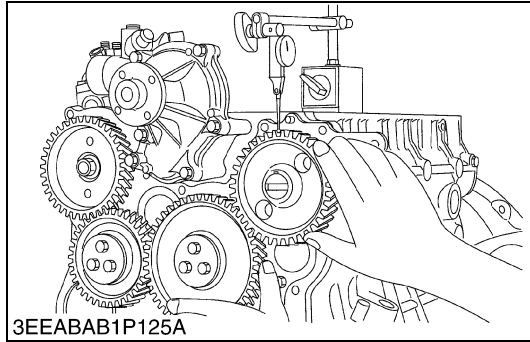

### Timing Gear Backlash

1. Set a dial indicator (lever type) with its tip on the gear tooth.
2. Move the gear to measure the backlash, holding its mating gear.
3. If the backlash exceeds the allowable limit, check the oil clearance of the shafts and the gear.
4. If the oil clearance is proper, replace the gear.

Backlash between crank gear and idle gear 1	Factory spec.	0.049 to 0.193 mm 0.0019 to 0.0076 in.
	Allowable limit	0.22 mm 0.0087 in.

Backlash between idle gear 1 and cam gear	Factory spec.	0.049 to 0.189 mm 0.0019 to 0.0074 in.
	Allowable limit	0.22 mm 0.0087 in.

Backlash between idle gear 1 and idle gear 2	Factory spec.	0.044 to 0.185 mm 0.0017 to 0.0073 in.
	Allowable limit	0.22 mm 0.0087 in.

Backlash between idle gear 2 and injection pump gear	Factory spec.	0.044 to 0.177 mm 0.0017 to 0.0070 in.
	Allowable limit	0.22 mm 0.0087 in.

Backlash between cam gear and balancer gear 1	Factory spec.	0.047 to 0.182 mm 0.0018 to 0.0072 in.
	Allowable limit	0.22 mm 0.0087 in.

Backlash between idle gear 1 and balancer gear 2	Factory spec.	0.044 to 0.183 mm 0.0017 to 0.0072 in.
	Allowable limit	0.22 mm 0.0087 in.

W1064048

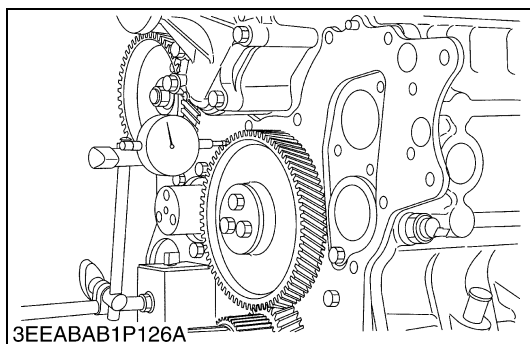

### Idle Gear Side Clearance

1. Set a dial indicator with its tip on the idle gear.
2. Measure the side clearance by moving the idle gear to the front and rear.
3. If the measurement exceeds the allowable limit, replace the idle gear collar.

Idle gear side clearance	Factory spec.	0.15 to 0.30 mm 0.0059 to 0.0118 in.
	Allowable limit	0.9 mm 0.0354 in.

W1064208

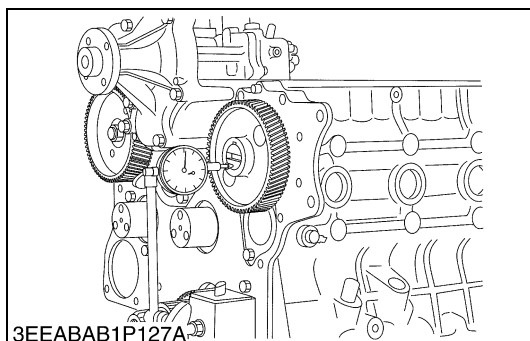

### Camshaft Side Clearance

1. Set a dial indicator with its tip on the camshaft.
2. Measure the side clearance by moving the cam gear to the front and rear.
3. If the measurement exceeds the allowable limit, replace the camshaft stopper.

Side clearance	Factory spec.	0.07 to 0.22 mm 0.0028 to 0.0087 in.
	Allowable limit	0.30 mm 0.0118 in.

W1064307  
KiSC issued 06, 2006 A

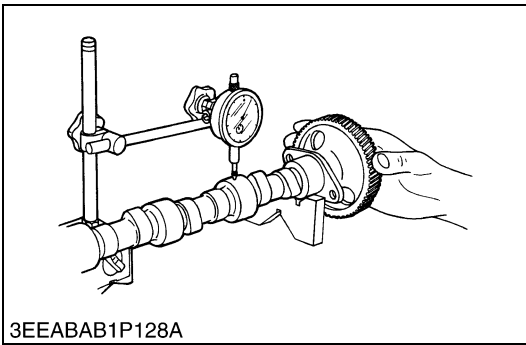

**Camshaft Alignment**

1. Support the camshaft with V block on the surface plate and set a dial indicator with its tip on the intermediate journal at right angle.
2. Rotate the camshaft on the V blocks and get the misalignment (half of the measurement).
3. If the misalignment exceeds the allowable limit, replace the camshaft.

Camshaft alignment	Allowable limit	0.01 mm 0.00039 in.
--------------------	-----------------	------------------------

W1064422

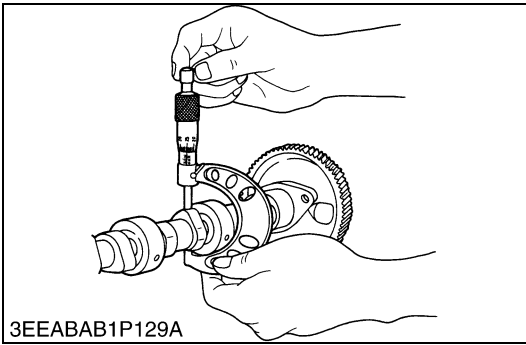

**Cam Height**

1. Measure the height of the cam at its highest point with an outside micrometer.
2. If the measurement is less than the allowable limit, replace the camshaft.

Intake and exhaust cam height	Factory spec.	Intake valve	37.63 mm 1.4815 in.
		Exhaust valve	38.96 mm 1.5338 in.
	Allowable limit	Intake valve	37.13 mm 1.4618 in.
		Exhaust valve	38.46 mm 1.5141 in.

W1064551

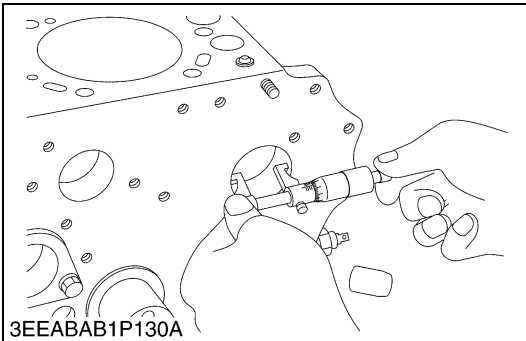

**Oil Clearance of Camshaft Journal**

1. Measure the camshaft journal O.D. with an outside micrometer.
2. Measure the cylinder block bore I.D. for camshaft with an inside micrometer.
3. If the clearance exceeds the allowable limit, replace the camshaft.

Oil clearance of camshaft journal	Factory spec.	0.050 to 0.091 mm 0.0020 to 0.0036 in.
	Allowable limit	0.15 mm 0.0059 in.

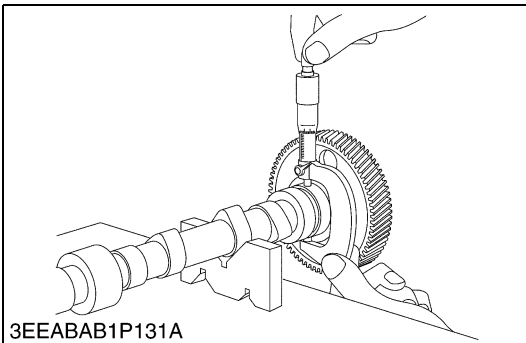

Camshaft journal O.D.	Factory spec.	45.934 to 45.950 mm 1.8084 to 1.8091 in.
Camshaft bearing I.D.	Factory spec.	46.000 to 46.025 mm 1.8110 to 1.8120 in.

W1064798

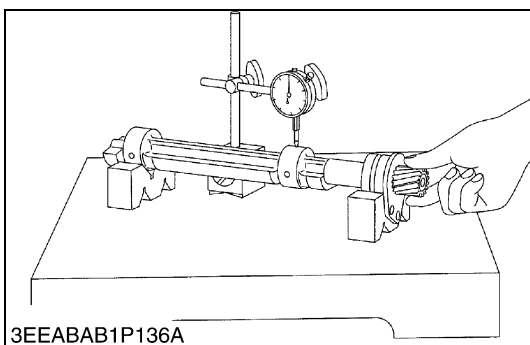
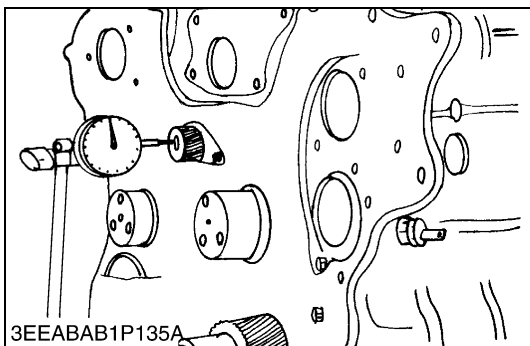
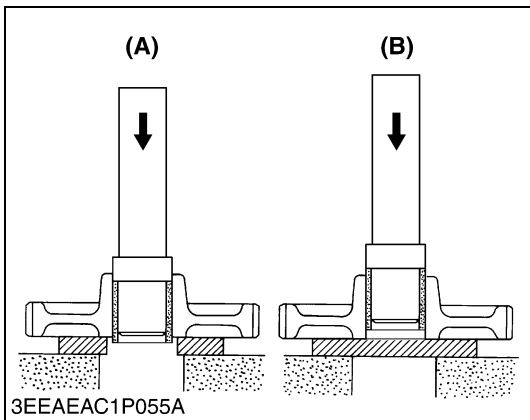
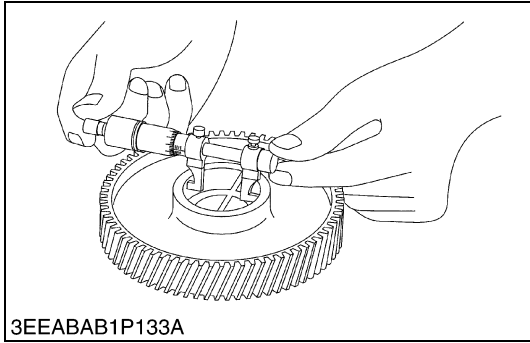
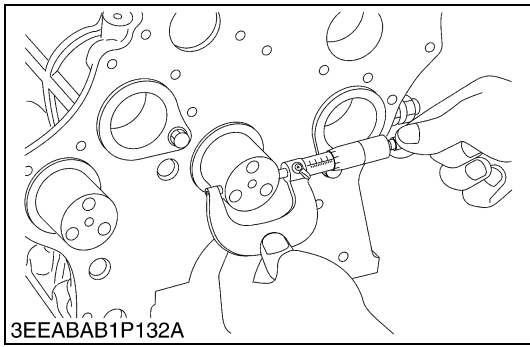

**Oil Clearance between Idle Gear Shaft 1, 2 and Idle Gear 1, 2 Bushing**

1. Measure the idle gear shaft O.D. with an outside micrometer.
2. Measure the idle gear bushings I.D. with an inside micrometer, and calculate the oil clearance.
3. If the oil clearance exceeds the allowable limit, replace the bushing.

Oil clearance between idle gear 1, 2 shaft and idle gear 1, 2 bushing	Factory spec.	0.050 to 0.091 mm 0.0020 to 0.0036 in.
	Allowable limit	0.10 mm 0.0039 in.

Idle gear 1, 2 bushing I.D.	Factory spec.	45.025 to 45.050 mm 1.7726 to 1.7736 in.
Idle gear 1, 2 shaft O.D.	Factory spec.	44.959 to 44.975 mm 1.7700 to 1.7707 in.

W1064968

**Replacing Idle Gear Bushing**

**(When removing)**

1. Using an idle gear bushing replacing tool, press out the used bushing.

**(When installing)**

1. Clean a new idle gear bushing and idle gear bore, and apply engine oil to them.
2. Using an idle gear bushing replacing tool, press in a new bushing (service parts) to the specified dimension. (See figure.)

(A) When Removing

(B) When Installing

W10302410

**Balancer Shaft Side Clearance**

1. Set a dial indicator with tip on the balancer shaft.
2. Measure the side clearance by moving the balancer shaft to the front and rear.
3. If the measurement exceeds the allowable limit, replace the balancer shaft.

Side clearance	Factory spec.	0.070 to 0.22 mm 0.0028 to 0.0087 in.
	Allowable limit	0.3 mm 0.0118 in.

W1065273

**Balance Shaft Alignment**

1. Support the balancer shaft with V blocks on the surface plate and set a dial indicator with its tip on the intermediate journal at high angle.
2. Rotate the balancer shaft on the V block and get the misalignment (half of the measurement).
3. If the misalignment exceeds the allowable limit, replace the balancer shaft.

Balancer shaft alignment	Allowable limit	0.02 mm 0.0008 in.
--------------------------	-----------------	-----------------------

W1065448



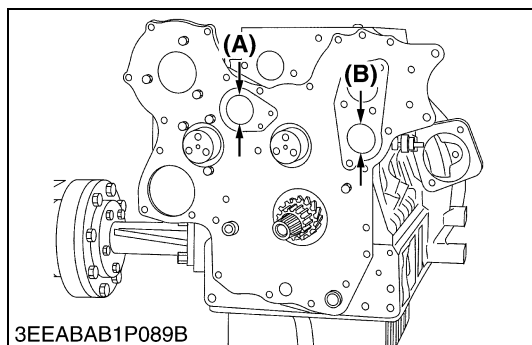

3EEABAB1P089B

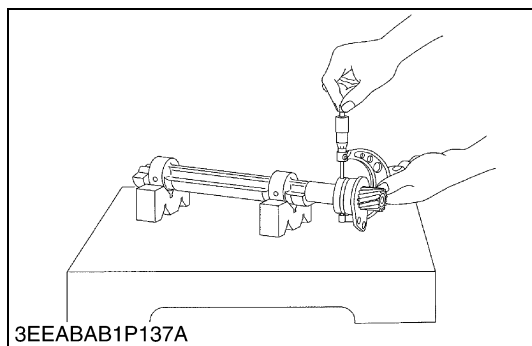

3EEABAB1P137A

### Oil Clearance of Balancer Shaft Journal

1. Measure the balancer shaft journal O.D. with an outside micrometer.
2. Measure the cylinder block bore I.D. (A), (B) for balancer shaft with an inside micrometer.
3. If the clearance exceeds the allowable limit, replace the balancer shaft.

Oil clearance of balancer-shaft journal	Factory spec.	0.070 to 0.159 mm 0.0028 to 0.0063 in.
	Allowable limit	0.2 mm 0.0079 in.

Balancer-shaft journal O.D.	Factory spec.	50.92 to 50.94 mm 2.0047 to 2.0055 in.
Balancer-shaft bearing I.D. (A), (B)	Factory spec.	51.01 to 51.08 mm 2.0083 to 2.0110 in.

(A) Balancer-shaft Bearing I.D.

(B) Balancer-shaft Bearing I.D.

W1065581

### (3) Piston and Connecting Rod

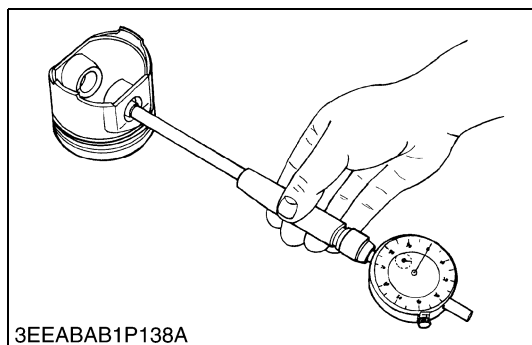

3EEABAB1P138A

### Piston Pin Bore I.D.

1. Measure the piston pin bore I.D. in both the horizontal and vertical directions with a cylinder gauge.
2. If the measurement exceeds the allowable limit, replace the piston.

Piston pin bore I.D.	Factory spec.	30.000 to 30.013 mm 1.1811 to 1.1816 in.
	Allowable limit	30.05 mm 1.1831 in.

W1065759

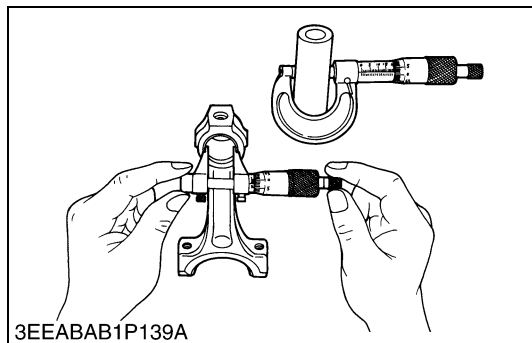

3EEABAB1P139A

### Oil Clearance between Piston Pin and Small End Bushing

1. Measure the O.D. of the piston pin where it contacts the bushing with an outside micrometer.
2. Measure the I.D. of the piston pin bushing at the connecting rod small end with a cylinder gauge. Calculate the oil clearance.
3. If the clearance exceeds the allowable limit, replace the bushing. If it still exceeds the allowable limit, replace the piston pin.

Oil clearance between piston pin and small end bushing	Factory spec.	0.020 to 0.040 mm 0.0008 to 0.0016 in.
	Allowable limit	0.15 mm 0.0059 in.

Piston pin O.D.	Factory spec.	30.006 to 30.011 mm 1.1813 to 1.1815 in.
Small end bushing I.D.	Factory spec.	30.031 to 30.046 mm 1.1823 to 1.1829 in.

W1065897

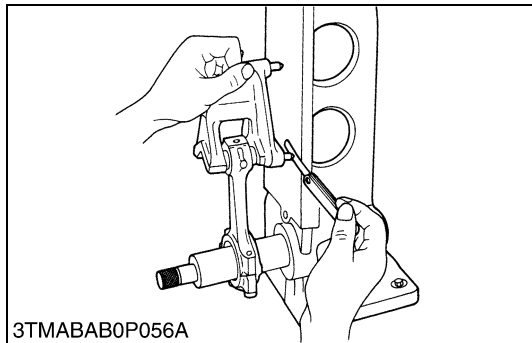
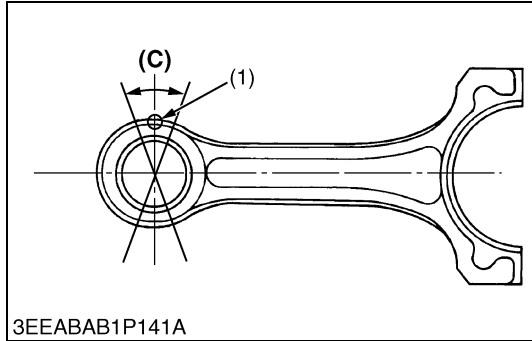
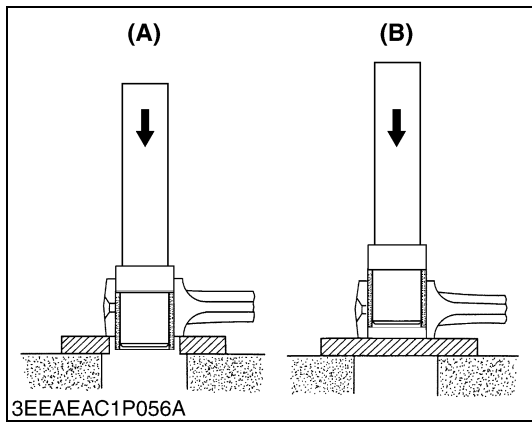

**Replacing Small End Bushing**

**(When removing)**

1. Press out the used bushing using a small end bushing replacing tool.

**(When installing)**

1. Clean a new small end bushing and bore, and apply engine oil to them.
2. Insert a new bushing onto the tool and press-fit it with a press so that the seam (1) of bushing position as shown in the figure, until is flash with the connecting rod.

(1) Seam

(A) When Removing

(B) When Installing

(C) 0.26 rad (15 °)

W1066057

**Connecting Rod Alignment**

**NOTE**

- Since the I.D. of the connecting rod small end bushing is the basis of this check, check the bushing for wear beforehand.
1. Remove the piston pin from the piston.
  2. Install the piston pin in the connecting rod.
  3. Install the connecting rod on the connecting rod alignment tool.
  4. Put a gauge over the piston pin, and move it against the face plate.
  5. If the gauge does not fit squarely against the face plate, measure the space between the pin of the gauge and the face plate.
  6. If the measurement exceeds the allowable limit, replace the connecting rod.

Connecting rod alignment	Allowable limit	0.05 mm 0.0020 in.
--------------------------	-----------------	-----------------------

W1066581

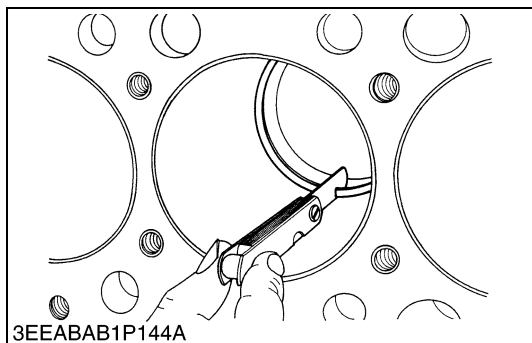

**Piston Ring Gap**

1. Insert the piston ring into the lower part of the liner (the least worn out part) with the piston.
2. Measure the ring gap with a feeler gauge.
3. If the gap exceeds the allowable limit, replace the piston ring.

Top ring and second ring	Factory spec.	0.30 to 0.45 mm 0.0118 to 0.0177 in.
	Allowable limit	1.25 mm 0.0492 in.

Oil ring	Factory spec.	0.25 to 0.45 mm 0.0098 to 0.0177 in.
	Allowable limit	1.25 mm 0.0492 in.

W1066430

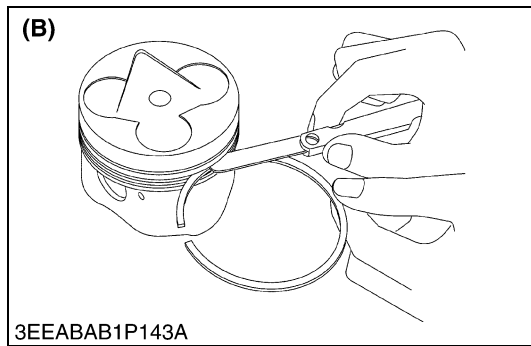
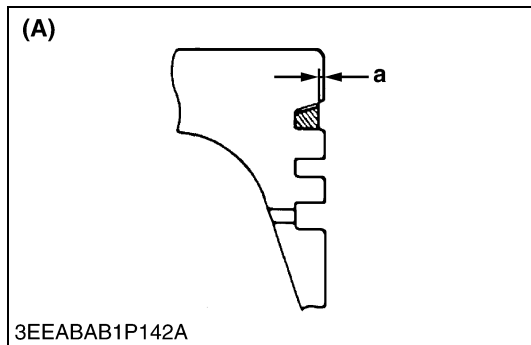

**Clearance between Piston Ring and Groove**

1. Remove carbon from the ring grooves.
2. Measure the clearance between the ring and the groove with a feeler gauge or depth gauge.
3. If the clearance exceeds allowable limit, replace the ring since compression leak and oil shortage result.
4. If the clearance still exceeds the allowable limit after replacing the ring, replace the piston.

Factory spec.	Second ring	0.093 to 0.120 mm 0.0037 to 0.0047 in.
	Oil ring	0.020 to 0.060 mm 0.0008 to 0.0023 in.
Allowable limit	Second ring	0.20 mm 0.0079 in.
	Oil ring	0.15 mm 0.0059 in.

Factory specification : a	More than 0.2 mm 0.079 in.
---------------------------	-------------------------------

(A) Top Ring (Key Stone Type)

(B) 2nd, Oil Ring

W1066183

**(4) Crankshaft**

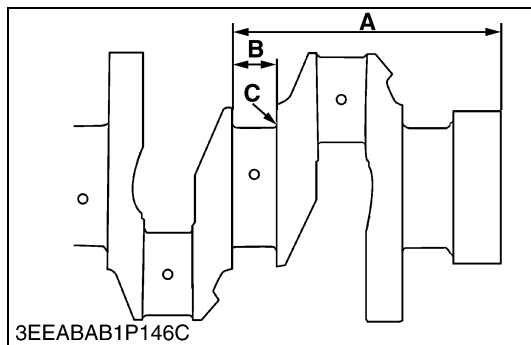
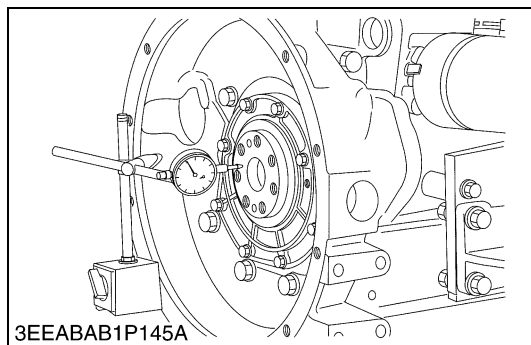

**Crankshaft Side Clearance**

1. Set a dial indicator with its tip on the end of the crankshaft.
2. Measure the side clearance by moving the crankshaft to the front and rear.
3. If the measurement exceeds the allowable limit, replace the thrust bearings.
4. If the same size bearing is useless because of the crankshaft journal wear, replace it with an oversize one referring to the table and figure.

Crankshaft side clearance	Factory spec.	0.15 to 0.31 mm 0.0059 to 0.0122 in.
	Allowable limit	0.50 mm 0.0197 in.

**(Reference)**

- Oversize dimensions of crankshaft journal.

Oversize	0.2 mm 0.008 in.	0.4 mm 0.016 in.
Dimension A	169.1 to 169.15 mm 6.6575 to 6.6594 in.	169.2 to 169.25 mm 6.6614 to 6.6634 in.
Dimension B	29.20 to 29.25 mm 1.1496 to 1.1515 in.	29.40 to 29.45 mm 1.1574 to 1.1594 in.
Dimension C	2.8 to 3.2 mm radius 0.1102 to 0.1260 in. radius	2.8 to 3.2 mm radius 0.1102 to 0.1260 in. radius
(0.8S)		
The crankshaft journal must be fine-finished to higher than ∇∇∇∇.		

W1066738

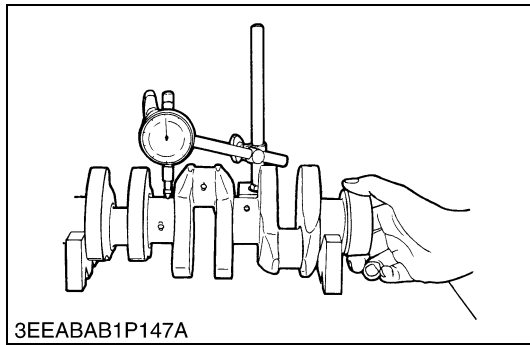

### **Crankshaft Alignment**

1. Support the crankshaft with V block on the surface plate and set a dial indicator with its tip on the intermediate journal at right angle.
2. Rotate the crankshaft on the V block and get the misalignment (half of the measurement).
3. If the misalignment exceeds the allowable limit, replace the crankshaft.

Crankshaft alignment	Allowable limit	0.02 mm 0.00079 in.
----------------------	-----------------	------------------------

W1067285

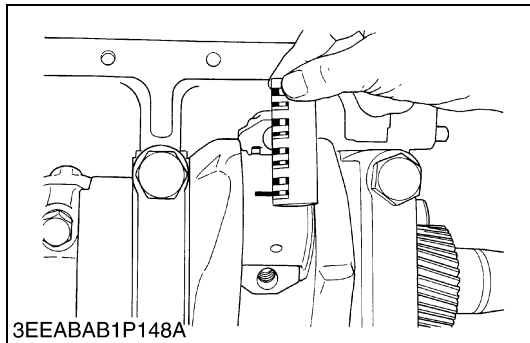

### **Oil Clearance between Crankpin and Crankpin Bearing**

1. Clean the crankpin and crankpin bearing.
2. Put a strip of plastigage on the center of the crankpin.
3. Install the connecting rod cap and tighten the connecting rod screws to the specified torque, and remove the cap again.
4. Measure the amount of the flattening with the scale, and get the oil clearance.
5. If the oil clearance exceeds the allowable limit, replace the crankpin bearing.
6. If the same size bearing is useless because of the crankpin wear, replace it with an undersize one referring to the table and figure.

#### ■ NOTE

- Never insert the plastigage into the crankpin oil hole.
- Be sure not to move the crankshaft while the connecting rod screws are tightened.

Crankpin O.D.	Factory spec.	52.977 to 52.990 mm 2.0857 to 2.0862 in.
---------------	---------------	---

Oil clearance between crankpin and crankpin bearing	Factory spec.	0.018 to 0.051 mm 0.0007 to 0.0020 in.
	Allowable limit	0.20 mm 0.0079 in.

W1067389

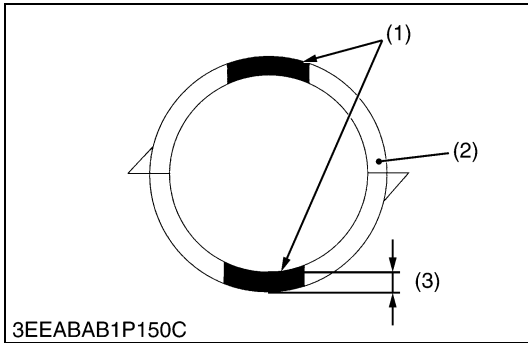
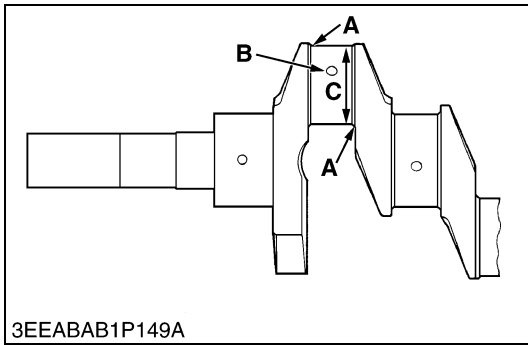

**Oil Clearance between Crankpin and Crankpin Bearing (Continued)**

**■ IMPORTANT**

- **STD size crankpin bearing.**  
To replace it with a specific STD service part, make sure the crankpin bearing has the same ID color as the connecting rod.

ID Color	Connecting rod	Crankpin bearing		
	Large-end in. dia.	Class	Part code	Center wall thick
Blue	56.01 to 56.02 mm 2.2051 to 2.2055 in.	L	1C020-22311	1.496 to 1.501 mm 0.0589 to 0.0591 in.
Without color	56.00 to 56.01 mm 2.2047 to 2.2051 in.	S	1C020-22331	1.491 to 1.496 mm 0.0587 to 0.0589 in.

**(Reference)**

- Undersize dimensions of crankpin

Undersize	0.2 mm 0.008 in.	0.4 mm 0.016 in.
Dimension A	2.8 to 3.2 mm radius 0.1102 to 0.1260 in. radius	2.8 to 3.2 mm radius 0.1102 to 0.1260 in. radius
*Dimension B	1.0 to 1.5 mm relief 0.0394 to 0.0591 in. relief	1.0 to 1.5 mm relief 0.0394 to 0.0591 in. relief
Dimension C	52.777 to 52.790 mm dia. 2.0778 to 2.0783 in. dia.	52.577 to 52.590 mm dia. 2.0700 to 2.0705 in. dia.

(0.8S)

The crankpin must be fine-finished to higher than ∇∇∇∇.  
\*Holes to be de-burred and edges rounded with 1.0 to 1.5 mm (0.0394 to 0.0591 in.) relief.

(1) ID Color  
(2) Crankpin Bearing

(3) Center Wall Thick

W1067741

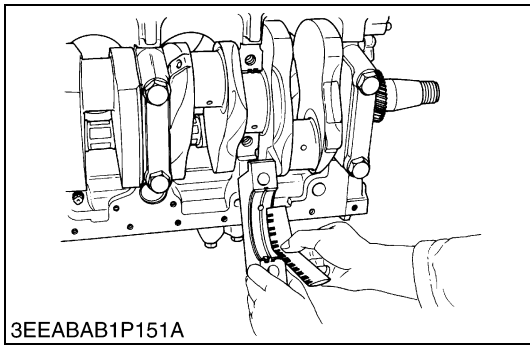

3EEABAB1P151A

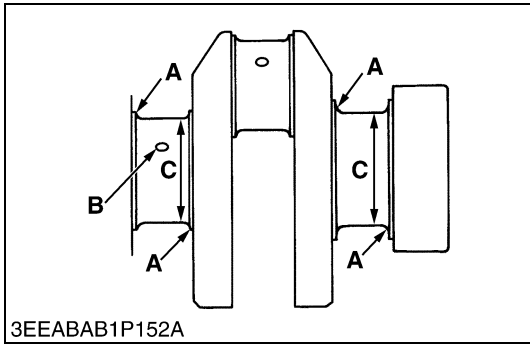

3EEABAB1P152A

**Oil Clearance between Crankshaft Journal and Crankshaft Bearing**

1. Clean the crankshaft journal and crankshaft bearing.
2. Put a strip of press gauge on the center of the journal.

**IMPORTANT**

- **Never insert the press gauge into the oil hole of the journal.**
3. Install the main bearing case and tighten the screws to the specified torque, and remove the cases again.
  4. Measure the amount of the flattening with the scale and get the oil clearance.
  5. If the clearance exceeds the allowable limit, replace the crankshaft bearing.

Crankshaft journal O.D.	Factory spec.	74.977 to 74.990 mm 2.9518 to 2.9524 in.
-------------------------	---------------	---

Oil clearance between crankshaft journal and crankshaft bearing	Factory spec.	0.018 to 0.062 mm 0.0007 to 0.0024 in.
	Allowable limit	0.20 mm 0.0079 in.

**(Reference)**

- Undersize dimensions of crankshaft journal.

Undersize	0.2 mm 0.008 in.	0.4 mm 0.016 in.
Dimension A	2.8 to 3.2 mm radius 0.1102 to 0.1260 in. radius	2.8 to 3.2 mm radius 0.1102 to 0.1260 in. radius
*Dimension B	1.0 to 1.5 mm relief 0.0394 to 0.0591 in. relief	1.0 to 1.5 mm relief 0.0394 to 0.0591 in. relief
Dimension C	74.777 to 74.790 mm dia. 2.9440 to 2.9445 in. dia.	74.577 to 74.590 mm dia. 2.9361 to 2.9366 in. dia.

(0.8S)  
The crankshaft journal must be fine-finished to higher than ∇∇∇∇.  
\*Holes to be de-burred and edges rounded with 1.0 to 1.5 mm (0.0394 to 0.0591 in.) relief.

W1069159

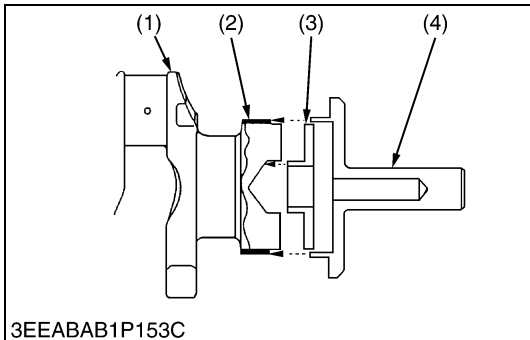

3EEABAB1P153C

**Replacing Crankshaft Sleeve**

1. Remove the used crankshaft sleeve (2).
2. Set the sleeve guide (3) to the crankshaft (1).
3. Heat a new sleeve to a temperature between 150 to 200 °C (302 to 392 °F), and fix the sleeve to the crankshaft as shown in figure.
4. Press fit the sleeve using the auxiliary socket for pushing (4).

**NOTE**

- **Mount the sleeve with its largely chamfered surface facing outward.**

- |                       |                                  |
|-----------------------|----------------------------------|
| (1) Crankshaft        | (3) Sleeve Guide                 |
| (2) Crankshaft Sleeve | (4) Auxiliary Socket for Pushing |

W1069911

### (5) Cylinder

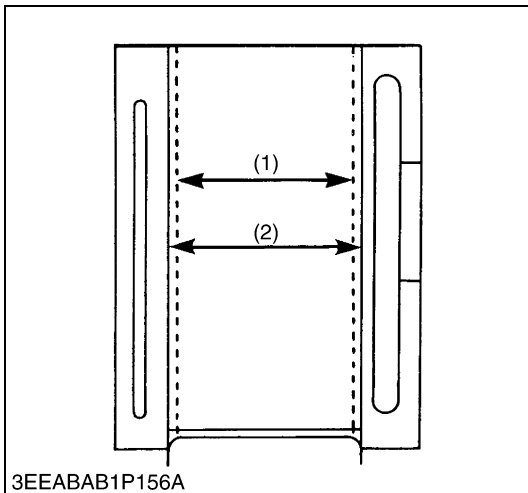
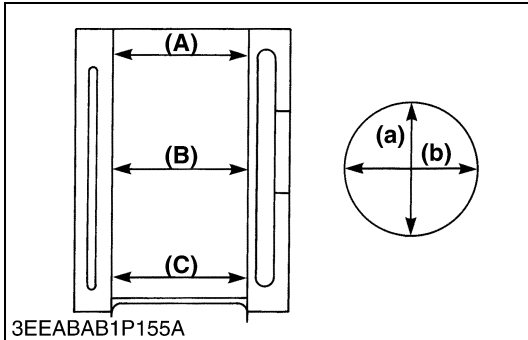
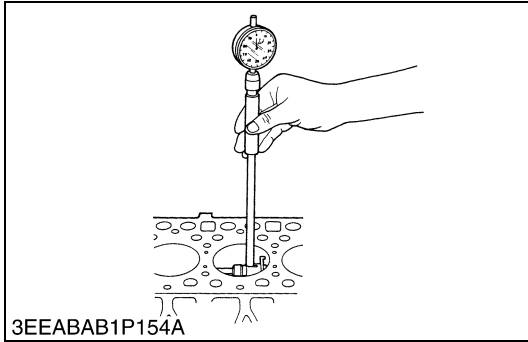

#### Cylinder Wear

1. Measure the I.D. of the cylinder at the six positions (see figure) with a cylinder gauge to find the maximum and minimum I.D.'s.
2. Get the difference (Maximum wear) between the maximum and the minimum I.D.'s.
3. If the wear exceeds the allowable limit, bore and hone to the oversize dimension. (Refer to “**Correcting Cylinder**”.)
4. Visually check the cylinder wall for scratches. If deep scratches are found, the cylinder should be bored. (Refer to “**Correcting Cylinder**”.)

Cylinder Bore I.D.	Factory spec.	98.000 to 98.022 mm 3.8582 to 3.8591 in.
	Allowable limit	98.15 mm 3.8642 in.

- (A) Top (a) Right-angled to piston pin  
 (B) Middle (b) Piston pin direction  
 (C) Bottom (Skirt)

W1070089

#### Correcting Cylinder (Oversize)

1. When the cylinder is worn beyond the allowable limit, bore and hone it to the specified dimension.

Cylinder I.D. (2)	Factory spec.	98.500 to 98.522 mm 3.8780 to 3.8788 in.
Maximum wear	Allowable limit	98.65 mm 3.8839 in.
Finishing	Hone to 1.2 to 3.0 μm Rz (0.000087 to 0.00012 in. Rz) ∇∇∇.	

2. Replace the piston and piston rings with oversize 0.5 mm (0.0197 in.) ones.

#### NOTE

- When the oversize cylinder is worn beyond the allowable limit, replace the cylinder block with a new one.

- (1) Cylinder I.D. (Before Correction) (2) Oversize Cylinder I.D.

W10344480

### (6) Oil Pump

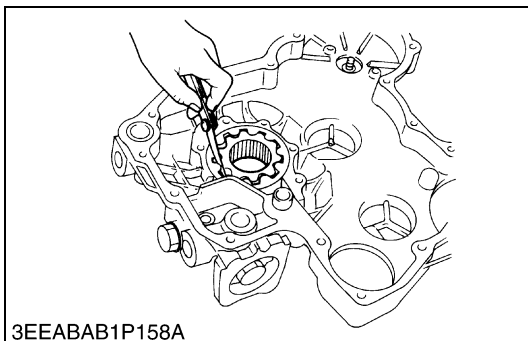

#### Rotor Lobe Clearance

1. Measure the clearance between lobes of the inner rotor and the outer rotor with a feeler gauge.
2. If the clearance exceeds the allowable limit, replace the oil pump rotor assembly.

Clearance between inner rotor and outer rotor	Factory spec.	0.04 to 0.16 mm 0.0016 to 0.0063 in.
	Allowable limit	0.3 mm 0.0118 in.

W1071254

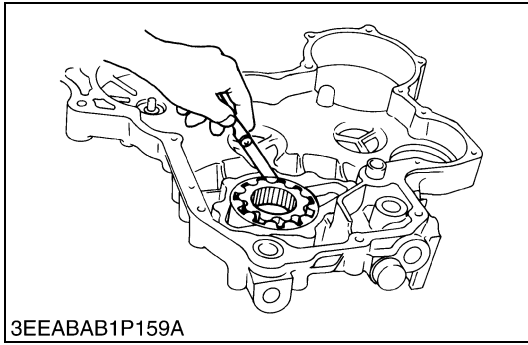

3EEABAB1P159A

### **Clearance between Outer Rotor and Pump Body**

1. Measure the clearance between the outer rotor and the pump body with a feeler gauge.
2. If the clearance exceeds the allowable limit, replace the oil pump rotor assembly.

Clearance between outer rotor and pump body	Factory spec.	0.100 to 0.184 mm 0.0039 to 0.0072 in.
	Allowable limit	0.3 mm 0.0118 in.

W1071334

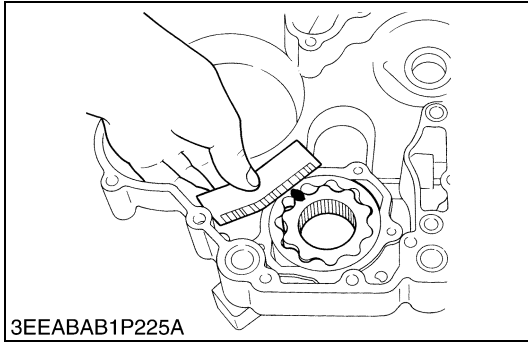

3EEABAB1P225A

### **Clearance between Rotor and Cover**

1. Put a strip of plastigage onto the rotor face with grease.
2. Install the cover and tighten the screws with the specified torque.
3. Remove the cover carefully, and measure the amount of the flattening with the scale and get the clearance.
4. If the clearance exceeds the allowable limit, replace oil pump rotor assembly and the cover.

Clearance between rotor and cover	Factory spec.	0.025 to 0.075 mm 0.0010 to 0.0030 in.
	Allowable limit	0.225 mm 0.0089 in.

Tightening torque	Oil pump cover screw	7.9 to 9.3 N·m 0.80 to 0.95 kgf·m 5.8 to 6.9 ft-lbs
-------------------	----------------------	---

W1148218

## **(7) Starter**

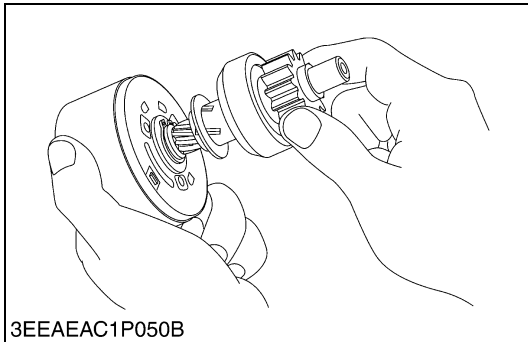

3EEAEAC1P050B

### **Overrunning Clutch**

1. Inspect the pinion for wear or damage.
2. If there is any defect, replace the overrunning clutch assembly.
3. Check that the pinion turns freely and smoothly in the overrunning direction and does not slip in the cranking direction.
4. If the pinion slips or does not rotate in the both directions, replace the overrunning clutch assembly.

W1075769



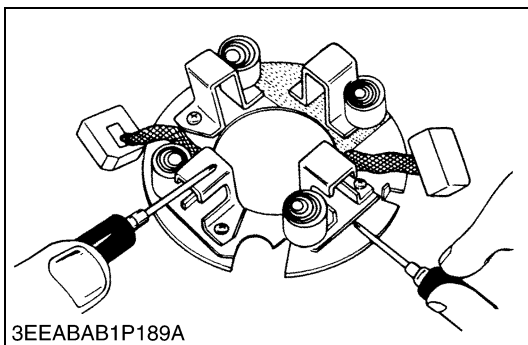
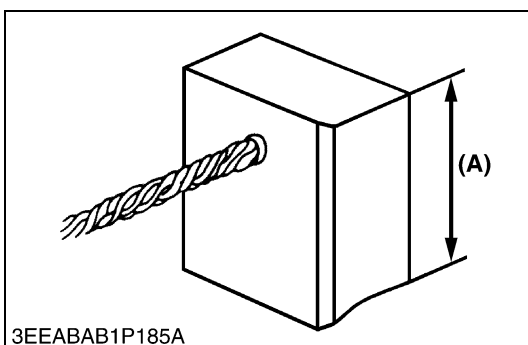
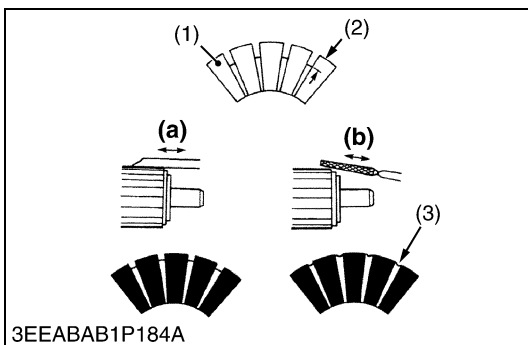
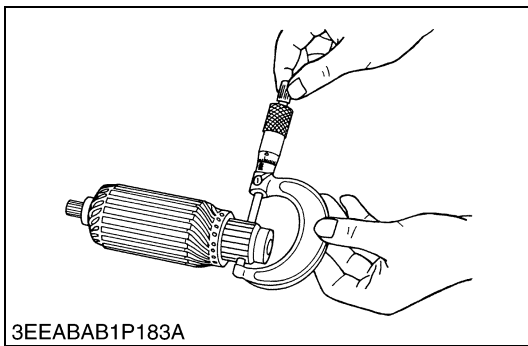
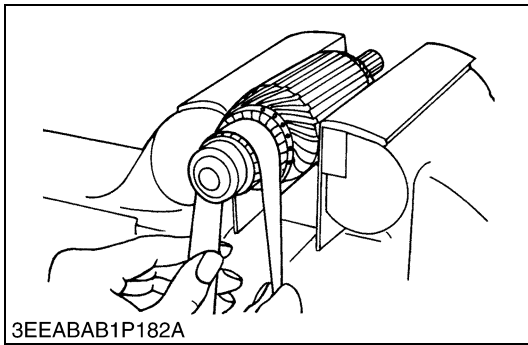

**Commutator and Mica**

1. Check the contact face of the commutator for wear, and grind the commutator with emery paper if it is slightly worn.
2. Measure the commutator O.D. with an outside micrometer at several points.
3. If the minimum O.D. is less than the allowable limit, replace the armature.
4. If the difference of the O.D.'s exceeds the allowable limit, correct the commutator on a lathe to the factory specification.
5. Measure the mica undercut.
6. If the undercut is less than the allowable limit, correct it with a saw blade and chamfer the segment edges.

Commutator O.D.	Factory spec.	32 mm 1.2598 in.
	Allowable limit	31.4 mm 1.2362 in.

Mica under cut	Factory spec.	0.5 mm 0.0197 in.
	Allowable limit	0.20 mm 0.0079 in.

- (1) Segment (a) Good
- (2) Depth of Mica (b) Bad
- (3) Mica

W1075277

**Brush Wear**

1. If the contact face of the brush is dirty or dusty, clean it with emery paper.
2. Measure the brush length (A) with vernier calipers.
3. If the length is less than the allowable limit, replace the yoke assembly and brush holder.

Brush length (A)	Factory spec.	18.0 mm 0.7086 in.
	Allowable limit	11.0 mm 0.4331 in.

(A) Brush Length

W1075476

**Brush Holder**

1. Check the continuity across the brush holder and the holder support with an ohmmeter.
2. If it conducts, replace the brush holder.

Resistance	Brush holder – Holder support	Infinity
------------	-------------------------------	----------

W1076066

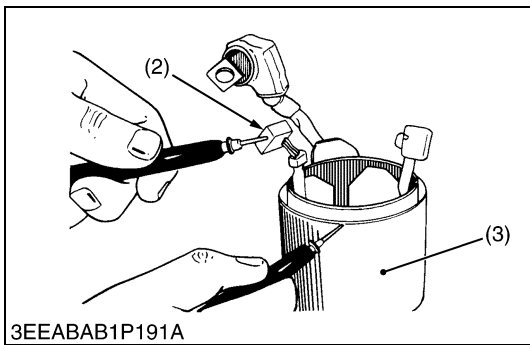
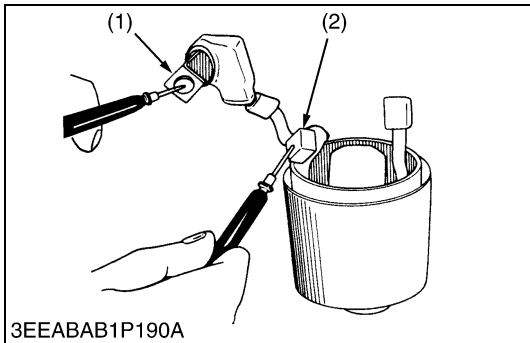
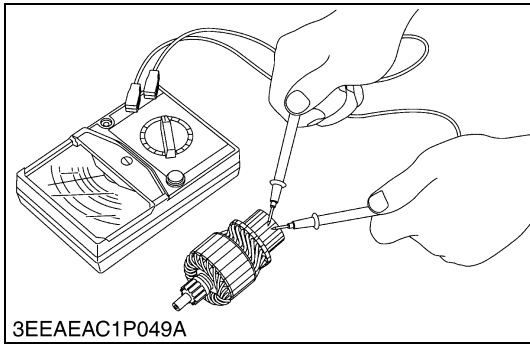
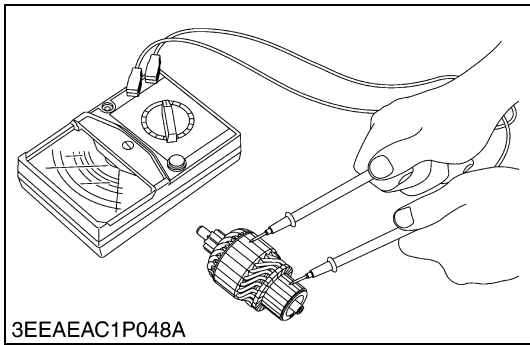

**(8) Alternator**

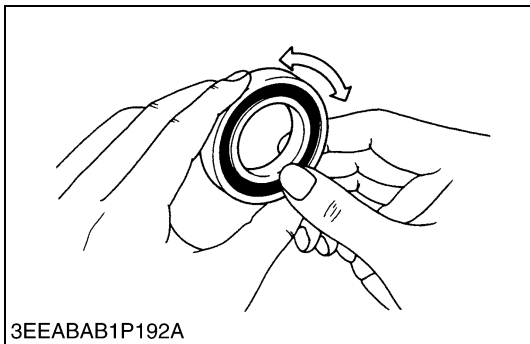

**Armature Coil**

1. Check the continuity across the commutator and armature coil core with an ohmmeter.
2. If it conducts, replace the armature.
3. Check the continuity across the segments of the commutator with an ohmmeter.
4. If it does not conduct, replace the armature.

Resistance	Commutator – Armature coil core	Infinity
	Commutator segment	0 Ω

W1075693

**Field Coil**

1. Check the continuity across the lead (1) and brush (2) with an ohmmeter.
2. If it does not conduct, replace the yoke assembly.
3. Check the continuity across the brush (2) and yoke (3) with an ohmmeter.
4. If it conducts, replace the yoke assembly.

Resistance	Lead (1) – Brush (2)	0 Ω
	Brush (2) – Yoke (3)	Infinity

- (1) Lead
- (2) Brush
- (3) Yoke

W1076156

**Bearing**

1. Check the bearing for smooth rotation.
2. If it does not rotate smoothly, replace it.

W1076281

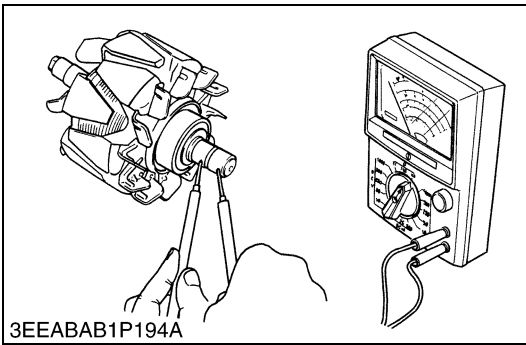
**Rotor**

1. Measure the resistance across the slip rings with an ohmmeter.
2. If the resistance is not the factory specification, replace it.
3. Check the continuity across the slip and core with an ohmmeter.
4. If infinity is not indicated, replace it.

Resistance	Factory spec.	2.8 to 3.3 $\Omega$
------------	---------------	---------------------

W1076422

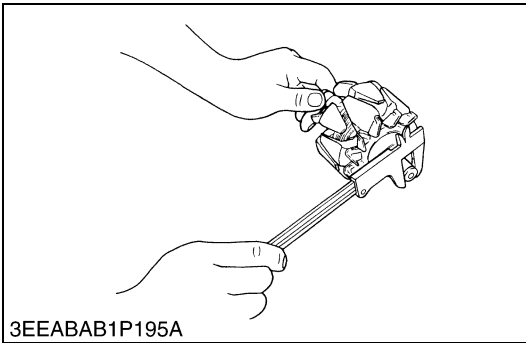
**Slip Ring**

1. Check the slip ring for score.
2. If scored, correct with an sand paper or on a lathe.
3. Measure the O.D. of slip ring with vernier calipers.
4. If the measurement is less than the allowable limit, replace it.

Slip ring O.D.	Factory spec.	22.7 mm 0.894 in.
	Allowable limit	22.1 mm 0.870 in.

W1076592

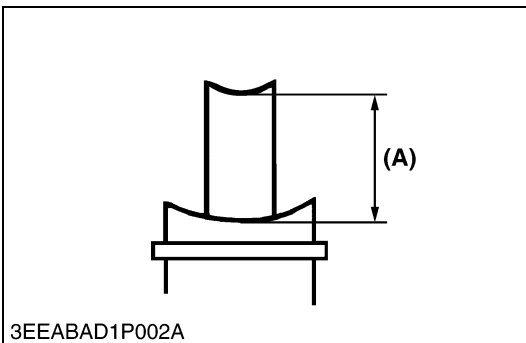
**Brush Wear**

1. Measure the brush length **(A)** with vernier calipers.
2. If the measurement is less than allowable limit, replace it.
3. Make sure that the brush moves smoothly.
4. If the brush is defective, replace it.

Brush length <b>(A)</b>	Factory spec.	18.5 mm 0.728 in.
	Allowable limit	5.0 mm 0.197 in.

**(A) Brush Length**

W1076714

---

**EDITOR:**

KUBOTA FARM & INDUSTRIAL MACHINERY SERVICE, LTD.

64, ISHIZU-KITAMACHI, SAKAI-KU, SAKAI-CITY, OSAKA, 590-0823, JAPAN

PHONE : (81)72-241-1129

FAX : (81)72-245-2484

E-mail : ksos-pub@kubota.co.jp

---