

**MODEL L4GC**  
**SHOP MANUAL**  
**(FOR INDUSTRIAL USE)**



# FORWARD

We would like to express our sincere gratitude to the patrons who have given us unwavering encouragement. This manual covers shop manual and parts catalog in one volume for an easy reference of parts list, as well as contains the accurate and efficient service procedures for HYUNDAI L4GC industrial engine.

This manual includes specifications, troubleshooting, removal, installation, disassembly and assembly in each group and presents component illustrations and descriptions for an easy reference.

Accordingly, thoroughly read this manual, rapidly purchase the required parts and service the engine in proper methods to extend its life and benefit.

Improper service methods and procedures may shorten the engine life resulting from its low performance. Hyundai genuine parts are designed and built to provide the best performance in your engine. If your claim is caused by using non-Hyundai genuine parts or servicing at places not recommended, your warranty is not available.

Hyundai Motor Co., Inc. makes efforts to enhance quality and build better parts and service data for you. We want to assist you in every way possible with this manual and your purchase of HYUNDAI engine is highly appreciated.

October 2006

Hyundai Motor Co., Inc.  
Industrial Engine Development Team  
(TEL 052-280-8221~8223)

O.E.M Parts Export Team  
(TEL 02-746-0291~0298)

NOTE: Contents and specifications are subject to change according to design changes without notice.

# IMPORTANT SAFETY NOTICE

Appropriate service methods and proper repair procedures are essential for the safe, reliable operation of all engines as well as the personal safety during work. This manual provides general directions for the efficient service methods and procedures.

There are numerous variations in procedure, techniques, tools and parts for servicing engines, as well as in the skill of the individual technician.

This manual cannot possibly anticipate all such variations and provide advice or cautions as to each.

Accordingly, anyone who departs from the instructions provided in this manual must establish that he comprises neither his personal safety nor the vehicle integrity by his choice of methods, tools or parts.

## NOTE, CAUTION, WARNING



**NOTE :** *Information needed in reference to a repair service.*



**CAUTION:** *Information about an activity that could cause damage to the vehicle.*



**WARNING :** *Information about an activity that could cause injury or damage to the driver, occupants or repairman.*

## [SAFETY INFORMATION]

The following list contains some general warnings that you should follow when you work on an engine.

- Always wear safety glasses for eye protection.
- Be sure that the ignition switch is always in the OFF position, unless otherwise required by the procedure.
- Operate the engine only in a well-ventilated area to avoid the danger carbon monoxide poisoning.
- Keep yourself and your clothing away from moving parts when the engine is running, especially the drive belt.
- To prevent serious burns, avoid contact with hot metal parts such as the radiator, exhaust manifold, tail pipe, catalytic converter and muffler.
- Do not smoke while working on an engine.
- To avoid injury, always remove rings, watches, loose hanging jewelry and loose clothing before beginning to work on an engine.
- Keep hands and other objects clear of the radiator fan.  
The fan can be operated with the ignition key in the OFF position. Therefore necessarily disconnect the radiator fan motor connector.

# CONTENTS

<b>1. GENERAL</b>	<b>1-1</b>
<b>2. ENGINE MECHANICAL SYSTEM</b>	<b>2-1</b>
<b>3. ENGINE ELECTRICAL SYSTEM</b>	<b>3-1</b>
<b>4. FUEL SYSTEM</b>	<b>4-1</b>

# CHAPTER 1. GENERAL

1. GENERAL .....	1- 1
2. RECOMMENDED LUBRICANTS AND CAPACITIES .....	1- 5
3. SCHEDULED MAINTENANCE .....	1- 6



## ENGINE IDENTIFICATION NUMBER LOCATION

The engine identification number is stamped on the left side of the top edge of the exhaust manifold cylinder block.

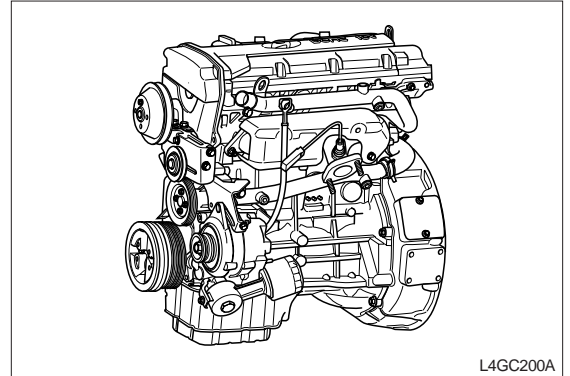

## ENGINE IDENTIFICATION NUMBER

The engine identification number consists of 11 digits.

L	4	G	C	X	0	0	0	0	0	1
1	2	3	4	5	6					

1. Engine fuel  
L : LPG
2. Engine range  
4 : In line 4 cycle 4 cylinder
3. Engine development order  
G :  $\beta$  engine
4. Engine capacity  
C: 1975 CC ( $\beta$  engine)
5. Production year  
1 : 2001      2 : 2002      3 : 2003  
4 : 2004      5 : 2005      6 : 2006
6. Engine production sequence number  
000001 ~ 999999

## SAFETY NOTICE

### 1. REMOVING AND DISASSEMBLING

After finding the malfunctioning reason and determining the removal and disassembly if necessary, simultaneously with checking the defect parts, start the job as the instruction of the shop manual.

To prevent mal-assembly and to ease job, put punch marks or identification marks on the places where not affect normal function and exterior.

Arrange multi-piece parts and similar parts in order when disassembling not to make a mistake while reassembling.

- 1) Arrange the removed parts in order.
- 2) Sort replacement parts and re-use parts
- 3) When replacing bolts and nuts, necessarily use the specified standard parts.

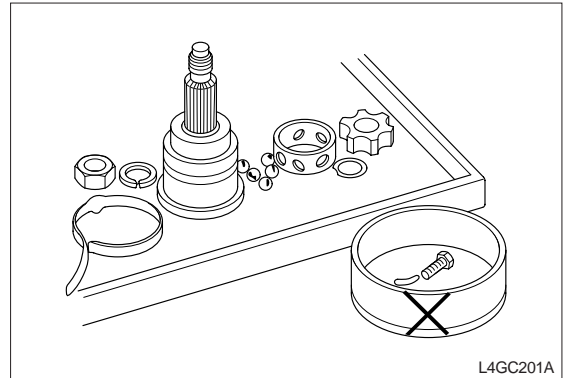

### 2. SPECIAL TOOL

Necessarily use the special tool as instruction to prevent parts from damage as result of using other general tool.

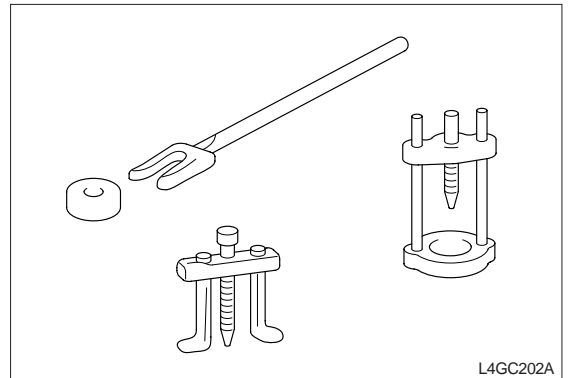

### 3. REPLACEMENT PARTS

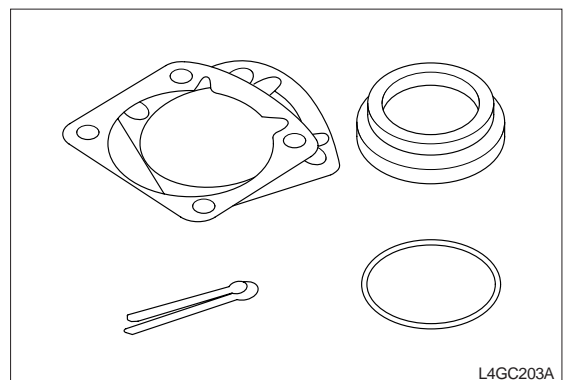

The following parts should be replaced with new parts after removing.

- 1) Oil seal
- 2) Gasket (except the locker cover gasket)
- 3) Packing
- 4) O-ring
- 5) Locker washer
- 6) Split pin



## 4. PARTS

- 1) When replacing parts, necessarily use the Hyundai genuine parts.
- 2) It is recommended to use spare parts prepared in the set or kit.
- 3) Spare parts can be different from actual assembled parts as the result of parts unification, so start the job after checking the parts catalog

 <b>HYUNDAI</b>	<b>Genuine parts</b>
	MOBIS MK IS MOBIS T BIS MOBIS TOBIS MOB
Certificate (attached)	Certificate (removed)
	L4GC204A

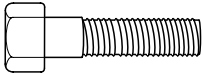
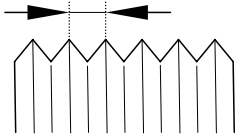
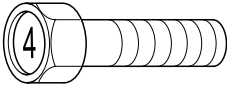
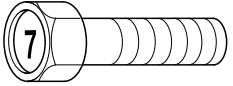

## TIGHTENING TORQUE TABLE OF STANDARD PARTS

Bolt nominal diameter (mm)	Pitch (mm)	Torque (kg·m)	
		Head mark 4	Head mark 7
 <small>L4GC205A</small>	 <small>L4GC206A</small>	 <small>L4GC207A</small>	 <small>L4GC208A</small>
M5	0.8	0.3 ~ 0.4	0.5 ~ 0.6
M6	1.0	0.5 ~ 0.6	0.9 ~ 1.1
M8	1.25	1.2 ~ 1.5	2.0 ~ 2.5
M10	1.25	2.5 ~ 3.0	4.0 ~ 5.0
M12	1.25	3.5 ~ 4.5	6 ~ 8
M14	1.2	7.5 ~ 8.5	12 ~ 14
M16	1.5	11 ~ 13	18 ~ 21
M18	1.5	16 ~ 18	26 ~ 30
M20	1.5	22 ~ 25	36 ~ 42
M22	1.5	29 ~ 33	48 ~ 55
M24	1.5	37 ~ 42	61 ~ 70

 NOTE

- **The torques shown in the table are standard values under the following conditions.**
  1. **Nuts and bolt are made of steel bar and galvanized.**
  2. **Galvanized plain steel washers are inserted.**
  3. **All nuts, bolts, plain washers are dry.**
- **The torques shown in the table are not applicable,**
  1. **When spring washers, toothed washers and the like are inserted.**
  2. **If plastic parts are fastened.**
  3. **If oil is applied to threads and surfaces.**
- **If you reduce the torques in the table to the percentage indicated below under the following conditions, it will be the standard value.**
  1. **If spring washers are used : 85%**
  2. **If threads and bearing surfaces are stained with oil: 85%**

**RECOMMENDED LUBRICANTS AND CAPACITIES****LUBRICANTS CAPACITIES**

Description		Capacities	Specified oil
Engine oil	Oil pan	3.7 l	Above API SG (10W/30 or 15W/40)
	Oil filter	0.3 l	
	Total	4.0 l	
Coolant (for engine)		3.0 l	It varies according to the radiator capacity

## SCHEDULED MAINTENANCE

### ENGINE OIL CLASSIFICATION

Recommended API classification: Above SG

Recommended SAE viscosity classification

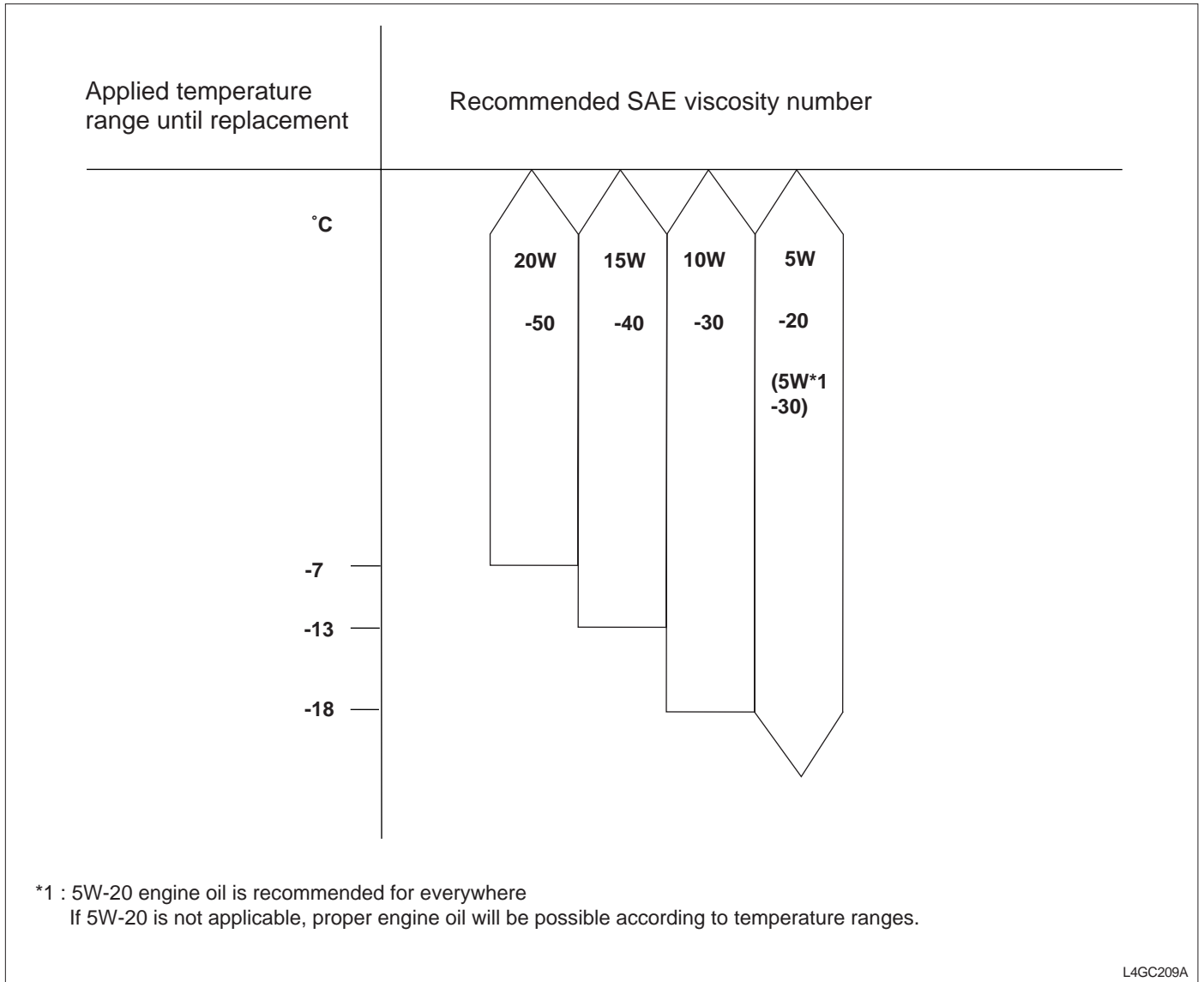

The following lubricants should be selected for all engines to enhance excellent performance and maximum effect.

1. Observe the API classification guide.
2. Proper SAE classification number should be selected within ambient temperature ranges. Do not use the lubricant with SAE classification number and API grade not identified on the container.

## CHECKING ENGINE OIL LEVEL

1. Check that the oil level is between “MIN” and “Max” marks on the engine oil level gauge.
2. If the oil level is below “MIN” mark, add oil until the level is within the specified ranges.
3. Check the engine for oil contamination and viscosity and replace if necessary.

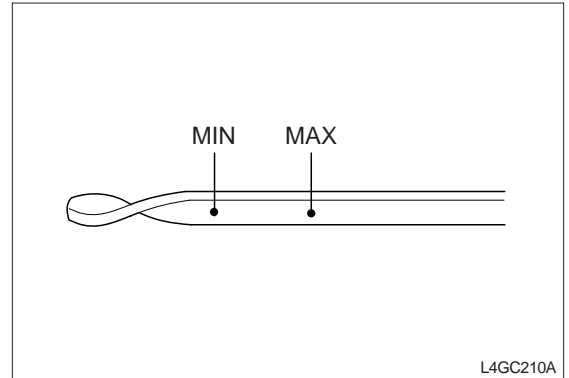

## REPLACING ENGINE OIL

1. When cooling the engine, warm up the engine up to the normal temperature.
2. Stop the engine.
3. After removing the oil filler cap, oil filter, and drain plug, drain the engine oil.
4. Tighten the drain plug to the specified torque(3.5~4.5kg·m).

**⚠ CAUTION**

***When installing the drain plug, always use a new plug gasket.***

5. Pour new engine oil to the oil filler.

Oil capacity (including filter)	4.0 ℓ
---------------------------------	-------

**⚠ CAUTION**

***Over replenishing can happen oil saturation and overpressure.***

6. Close the oil filler cap.
7. Run the engine.
8. Stop the engine and after checking the oil level, add oil if necessary.

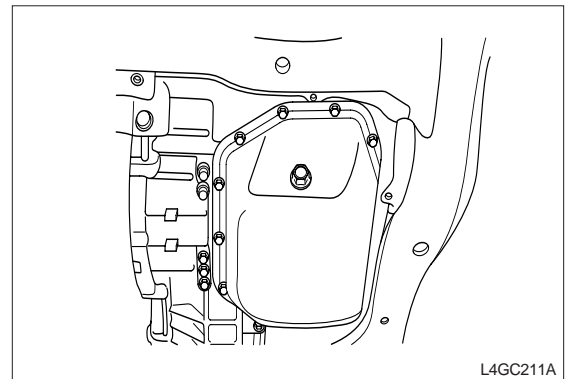

## REPLACING ENGINE OIL FILTER

1. Remove the oil filter using a filter wrench.
2. When installing new parts, after applying engine oil to the O-ring, tighten the oil filter securely by hand.
3. Tighten the oil filter to the specified torque.

Oil filter	1.2 ~ 1.6 kg·m
------------	----------------

4. Start the engine and inspect the oil leak.

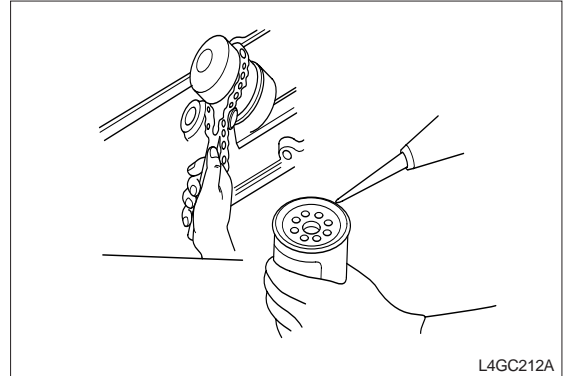

## CHECKING DRIVE BELT TENSION

1. Press the middle of the water pump pulley and alternator pulley with 10kg.f.
2. Inspect the belt deflection by pressing it.
3. If the belt deflection is out of the standard, adjust it as follows.

Item	Standard	
	New belt	Used belt
Drive belt deflection	4.0 ~ 4.4mm	5.1 ~ 5.7mm

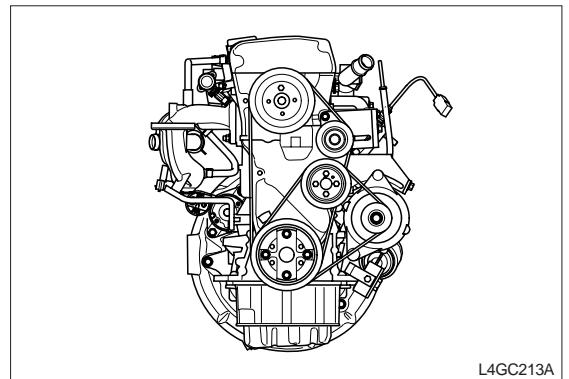

## CHECKING SPARK PLUG

### INSPECTION

1. Remove the spark plug from the cylinder head using a spark plug wrench.

**⚠ CAUTION**

**Prevent foreign material from getting in the spark plug fitting hole.**

2. Check the following items of the spark plug.

- 1) Damage of the insulator
- 2) Wear of the terminal
- 3) Carbon deposits
- 4) Damage of the gasket
- 5) Porcelain insulator in the spark plug clearance

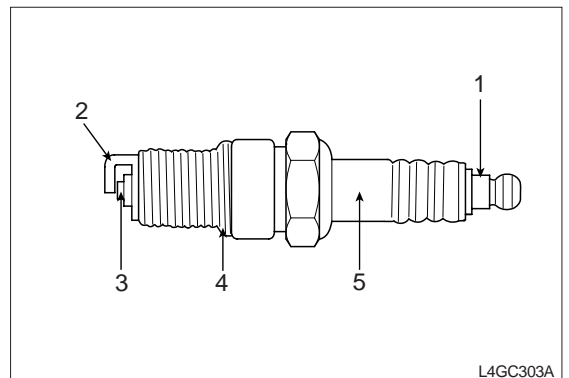

3. Check the plug clearance using a plug clearance gauge and if the value is not within the specified values, adjust it by bending the ground clearance.

When installing a new spark plug, install it after checking the uniform plug clearance.

Spark plug clearance	0.7 ~ 0.8mm
----------------------	-------------

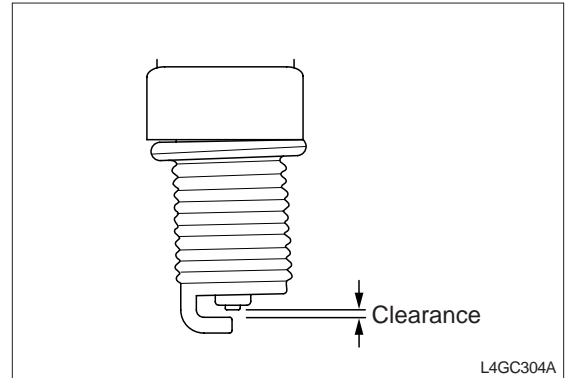

4. Install the spark plug and tighten it to the specified torque. Take care not to over tighten it to prevent cylinder head threads from damage.

**SPARK PLUG ANALYSIS**

State	Contact point is black	Contact point is white
Description	<ul style="list-style-type: none"> <li>· Density of the fuel mixture is thick</li> <li>· Lack of air intake</li> </ul>	<ul style="list-style-type: none"> <li>· Density of the fuel mixture is thin</li> <li>· Ignition timing is fast</li> <li>· Spark plug is tight</li> <li>· Lack of torque</li> </ul>

**SPARK PLUG TEST**

After connecting the spark plug to the high tension cable, connect the outer terminal(main body) to the ground and crank the engine.

Because the discharging clearance is narrow in the air, only slight spark will arise. But if the spark plug is defect, spark does not arise because insulation is damaged.

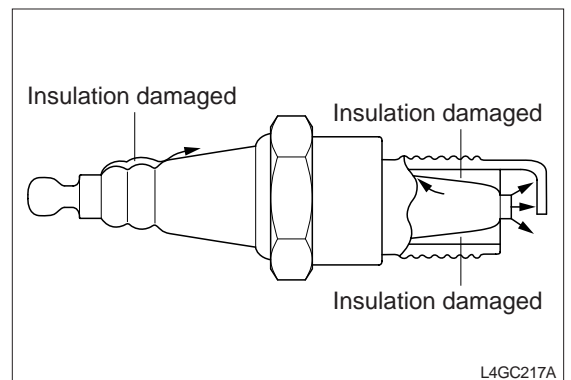

## REPLACING OXYGEN SENSOR

Oxygen sensor is as a fuel mixture control unit, if it is damaged, exhaust gas will be bad as well as engine performance. So, if the oxygen sensor is defected, necessarily replace it.

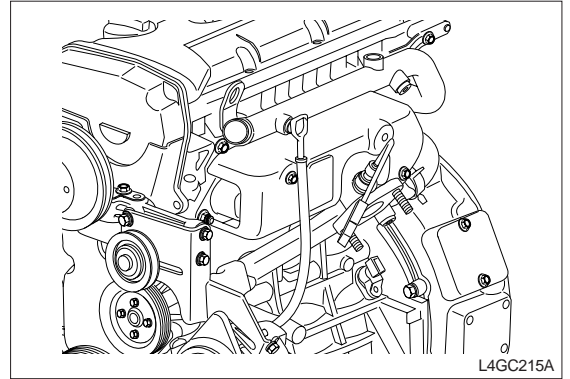

## COOLING SYSTEM

Check the cooling system hoses for damage and looseness or inspect the joints for coolant leaks.

## COOLANT

When the engine is delivered, the engine cooling system contains mixture of antifreeze(40%) and water(60%). Because the cylinder head and the water pump are made of aluminum alloy, the mixture should contain antifreeze (ethylene glycol) of 30~60% to prevent those from corrosion, freezing and bursting.

### NOTE

- ***If the coolant contains less than 30% of antifreeze, anticorrosion is decreased.***
- ***If the coolant contains more than 60% of antifreeze, the engine will be fatally affected, resulting from decreased anti-freezing and engine cooling. Use only the recommended antifreeze and do not mix with other production.***

Recommended antifreeze	Ethylene glycol
------------------------	-----------------

## COOLANT VISCOSITY MEASUREMENT

Run the engine until the coolant is mixed completely, drain a little of coolant to determine the coolant viscosity at a safe operating temperature, measure the coolant viscosity and adjust it to the specified value.

## REPLACING COOLANT

### CAUTION

*If the coolant is hot, injury can happen, so when the engine is hot, never open the radiator cap until the coolant temperature is dropped. When open the radiator cap, be careful of hot coolant or steam, surround the upper portion of the cap with a rag, slightly open it counterclockwise to drop the pressure through the reservoir tank tube, and then slowly turn the cap to open.*

1. After opening the radiator cap, loosen the drain plug and the engine drain plug and drain the coolant.
2. Remove the reservoir tank and drain the coolant.
3. After draining the coolant completely, close the drain plug, fill the engine and the radiator full with a radiator cleaner, and clean the engine and the radiator.
4. After completing the cleaning, drain the cleaner and close the radiator and engine drain plug.
5. After running the engine for a while, inspect the coolant level and add a coolant to the specified level.
6. Replenish the reservoir tank with a coolant until the level reads between “FULL” and “LOW” marks.



## **CHAPTER 2. ENGINE MECHANICAL SYSTEM**

<b>1. GENERAL .....</b>	<b>2- 1</b>
<b>2. CYLINDER BLOCK .....</b>	<b>2-20</b>
<b>3. MAIN MOVING SYSTEM .....</b>	<b>2-29</b>
<b>4. COOLING SYSTEM .....</b>	<b>2-56</b>
<b>5. LUBRICATION SYSTEM .....</b>	<b>2-62</b>
<b>6. INTAKE AND EXHAUST SYSTEM .....</b>	<b>2-64</b>
<b>7. CYLINDER HEAD ASSEMBLY .....</b>	<b>2-69</b>
<b>8. TIMING SYSTME .....</b>	<b>2-78</b>

GENERAL

OUTLINE

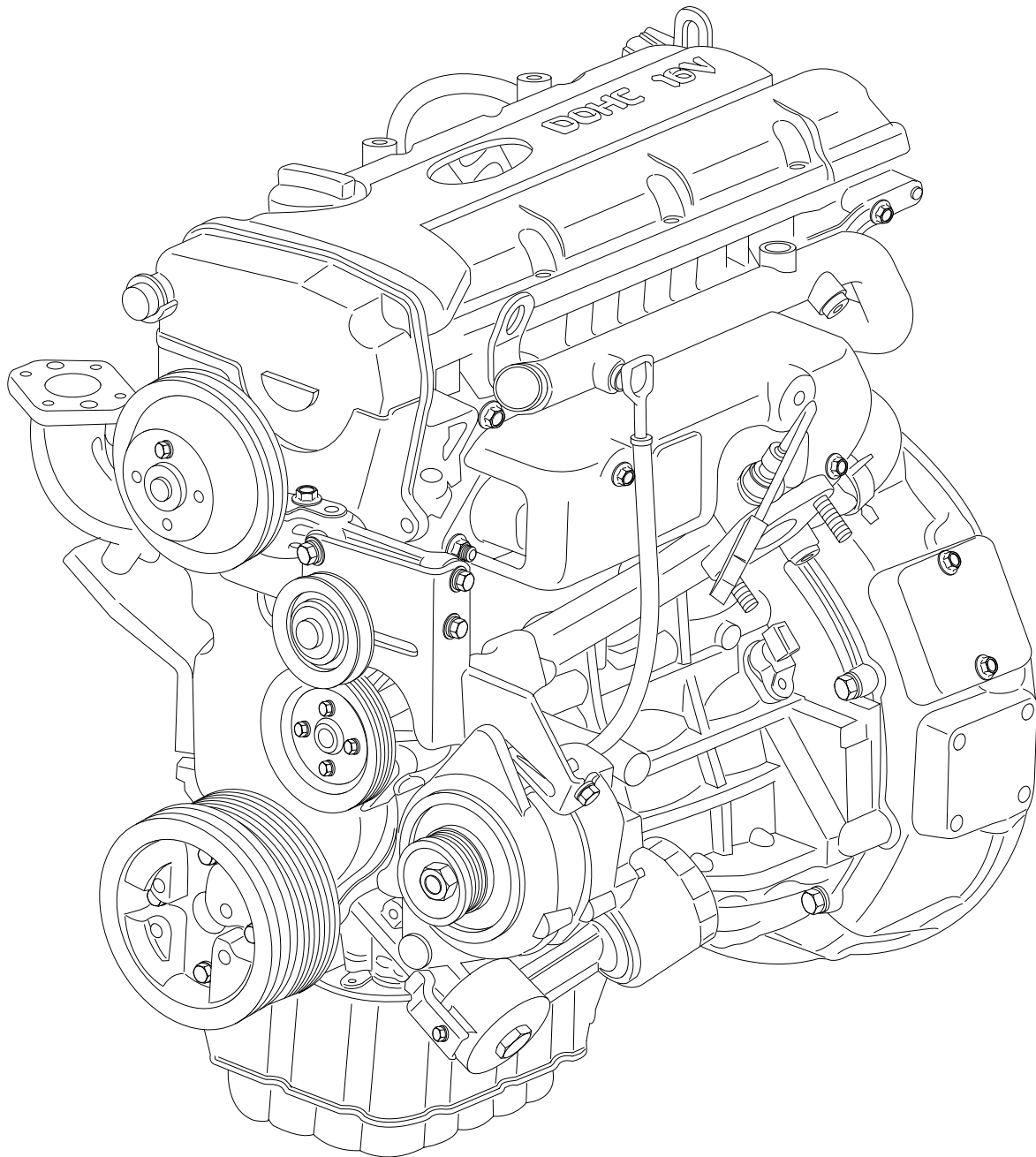

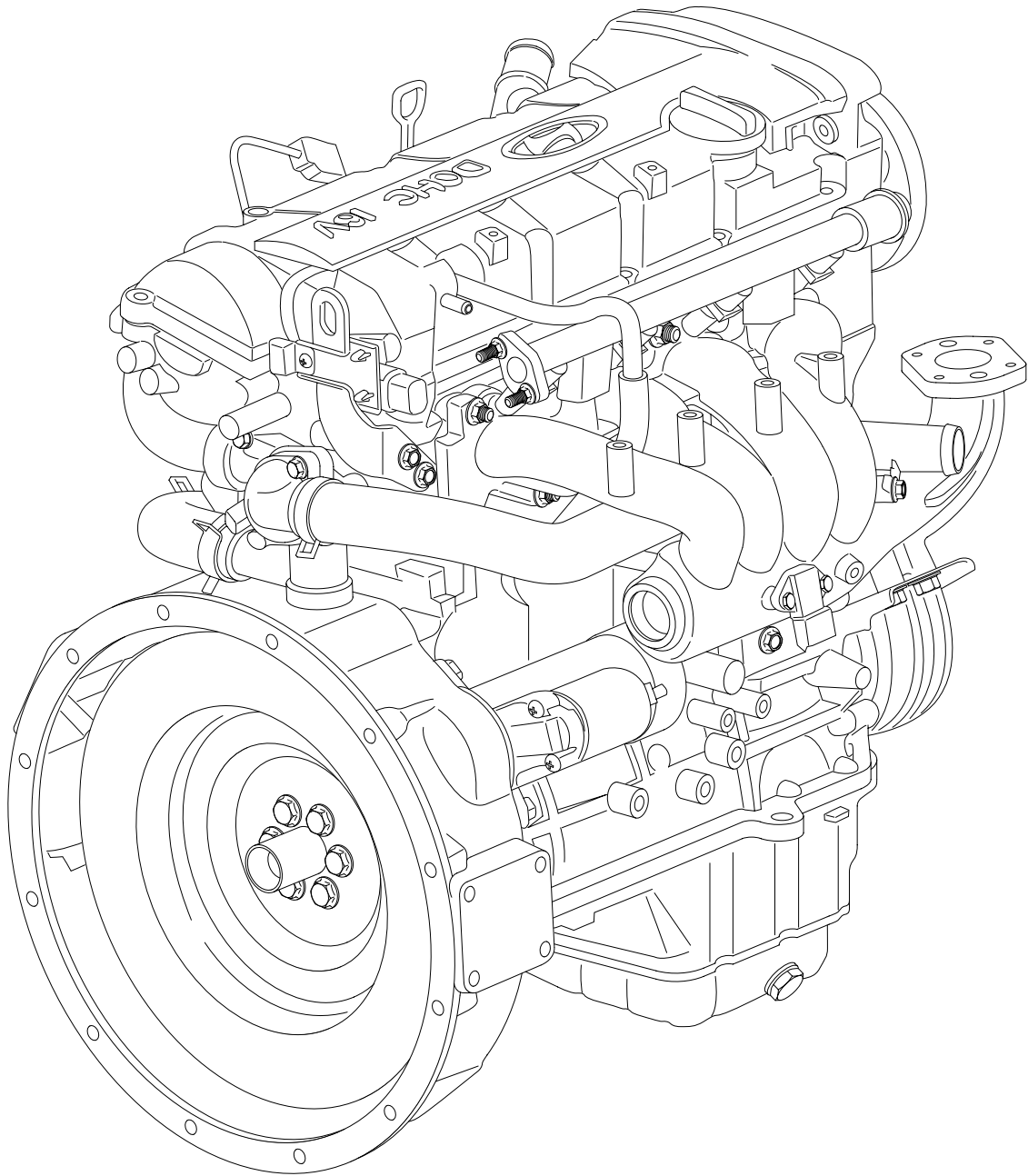

## GENERAL

## SPECIFICATIONS

Description	Specification	Limit
<b>GENERAL</b> Type Cylinder number Bore Stroke Displacement Compression ratio Firing order RPM Ignition timing Valve timing Intake Open Close Exhaust Open Close Valve over rap	Series, DOHC 4 82 mm 93.5 mm 1,975 cc 9.4 1 - 3 - 4 - 2 700 ± 100 rpm BTDC 8° ± 5 °  BTDC 2° ABDC 16°  BBDC 18° ATDC 2° 4 °	
<b>CYLINDER HEAD</b> Flatness of gasket surface Flatness of manifold mounting surface Oversize of valve seat hole Intake 0.3 OS 0.6 OS Exhaust 0.3 OS 0.6 OS Oversize of valve guide hole 0.05 OS 0.25 OS 0.50 OS	0.03 mm or less 0.15 mm or less  33.3 ~ 33.325 mm 33.6 ~ 33.625 mm  28.8 ~ 28.821 mm 29.1 ~ 29.121 mm  11.05 ~ 11.069 mm 11.25 ~ 11.268 mm 11.50 ~ 11.518 mm	0.06 mm 0.3 mm  0.2 mm
<b>CAMSHAFT</b> Cam height Intake Exhaust Journal O.D Bearing oil clearance End play	43 mm 43 mm ∅28 0.02 ~ 0.061 mm 0.1 ~ 0.2 mm	42.9 mm 42.9 mm

Description	Specification	Limit
<b>VALVE</b> Stem O.D Intake Exhaust Thickness of valve head (Margin) Intake Exhaust Valve stem to guide clearance Intake Exhaust	5.965 ~ 5.980 mm 5.950 ~ 5.965 mm  1.15 mm 1.35 mm  0.02 ~ 0.05 mm 0.035 ~ 0.065 mm	       0.8 mm 1.0 mm  0.1 mm 0.13 mm
<b>VALVE GUIDE</b> Length Installed size Over size	Intake : 46, Exhaust : 54.5 0.05, 0.25, 0.50	
<b>VALVE SEAT</b> Seat angle Over size	45° 0.3, 0.6	
<b>VALVE SPRING</b> Free length Load  Installed height Out-of squareness	48.86 mm 18.3kg/39 mm 40.0kg/30.5 mm 39 mm 1.5 mm or less	     3°
<b>CYLINDER BLOCK</b> Cylinder I.D Out-of cylindricity of cylinder I.D Cylinder block-to-piston clearance	82.00 ~ 82.03 mm Less than 0.01 mm 0.02 ~ 0.04	
<b>PISTON</b> O.D Over size	81.97 ~ 82.00 mm 0.25, 0.50, 0.75, 1.00	
<b>PISTON RING</b> Side clearance No.1 No.2 End gap No.1 No.2 Oil ring side rail Over size	0.04 ~ 0.08 mm 0.03 ~ 0.07mm  0.23 ~ 0.38 mm 0.33 ~ 0.48 mm 0.2 ~ 0.6 mm 0.25, 0.50, 0.75, 1.00	       0.1 mm 0.1 mm  1.0 mm 1.0 mm 1.0 mm
<b>CONNECTING ROD</b> Bend Twist Side clearance	0.05 mm or less 0.10 mm or less 0.100 ~ 0.250 mm	   0.4 mm

Description	Specification	Limit
<b>CONNECTING ROD BEARING</b> Oil clearance Under size	0.024 ~ 0.044 mm 0.25, 0.50, 0.75	
<b>CRANKSHAFT</b> Pin O.D Journal O.D Bend Out-of cylindricity of journal and pin End play Under size of pin 0.25 0.50 0.75 Under size of journal 0.25 0.50 0.75	45 mm 57 mm Less than 0.03 mm Less than 0.01 mm 0.06 ~ 0.260 44.725 ~ 44.740 mm 44.475 ~ 44.490 mm 44.225 ~ 44.240 mm 56.727 ~ 56.742 mm 56.477 ~ 56.492 mm 56.227 ~ 56.242 mm	
<b>OIL PUMP</b> O.D-to-front case clearance Front side clearance Tip clearance Outer gear Inner gear Oil pressure (Oil temperature 90°C~100°C) at idle (800rpm)	0.12 ~ 0.185 mm 0.025 ~ 0.069 mm 0.04 ~ 0.09 mm 0.04 ~ 0.085 mm 1.7kg/cm <sup>2</sup>	
<b>RELIEF SPRING</b> Free height Load	43.8 mm 3.7kg/40.1 mm	
Cooling type	Water-cooled forced circulation system, Mechanical cooling pan	
Water pump type Thermostat type Antifreeze viscosity	Centrifugal impeller Wax pellet type with jiggle valve 40%	
<b>THERMOSTAT</b> Valve open temperature Fully open temperature	82°C ± 1.5°C 95°C	
<b>WATER TEMPERATURE SENSOR</b> Type Resistance(at 20°C)	2.31K $\Omega$ ~ 2.59K $\Omega$	

## TORQUE SPECIFICATIONS

Description	Standard (Kg·m)
Cylinder block	
Engine support bracket bolt and nut	3.5 ~ 5.0
Engine support bracket spare bolt	4.3 ~ 5.5
Oil pressure switch	1.3 ~ 1.5
Cylinder head	
Cylinder head bolt	
M10	2.5+(60° ~ 65°) + (60° ~ 65°)
M12	3.0+(60° ~ 65°) + (60° ~ 65°)
Intake manifold bolt and nut	1.6 ~ 2.3
Exhaust manifold nut	4.3 ~ 5.5
Cylinder head cover bolt	0.8 ~ 1.0
Camshaft bearing cap bolt	1.4 ~ 1.5
Rear plate bolt	0.8 ~ 1.0
Main moving	
Connecting rod cap nut	5.0 ~ 5.3
Crankshaft bearing cap bolt	2.7 ~ 3.3+(60° ~ 65°)
Flywheel manual transmission bolt	12.0 ~ 13.0
Drive plate automatic transmission bolt	12.0 ~ 13.0
Timing belt	
Crankshaft pulley bolt	17 ~ 18
Camshaft sprocket bolt	10 ~ 12
Timing belt tensioner bolt	4.3 ~ 5.5
Timing belt idler bolt	4.3 ~ 5.5
Timing belt cover bolt	0.8 ~ 1.0
Front case bolt	2.0 ~ 2.7
Engine mounting	
Oil filter	1.2 ~ 1.6
Oil pan bolt	1.0 ~ 1.2
Oil pan drain plug	3.5 ~ 4.5
Oil screen	1.5 ~ 2.2
Oil seal case	1.0 ~ 1.2



Description	Standard (Kg·m)
Thermostat inlet fitting nut	1.5 ~ 2.0
Thermostat housing mounting nut	1.5 ~ 2.0
Water pump mounting bolt	2.0 ~ 2.7
Alternator brace bolt	2.0 ~ 2.7
Water temperature sensor	2.0 ~ 4.0
Alternator support bolt and nut	2.0 ~ 2.5
Water pump pulley	0.8 ~ 1.0
Intake manifold and cylinder head bolt	1.6 ~ 2.3
Intake manifold cover and intake manifold bolt	1.8 ~ 2.5
Throttle body and Surge tank nut	1.5 ~ 2.0
Exhaust manifold and cylinder head bolt	4.3 ~ 5.5
Exhaust manifold cover and intake manifold bolt	1.5 ~ 2.0
Oxygen sensor and intake manifold bolt	5.0 ~ 6.0
Water pipe bracket bolt	1.2 ~ 1.5
Chain guide	0.8 ~ 1.0
Starter bolt	2.7 ~ 3.4
Heater protector	1.5 ~ 2.0

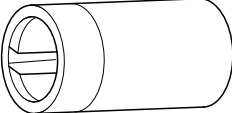
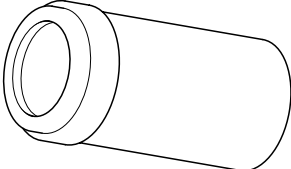
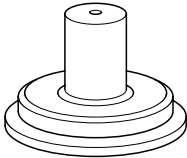
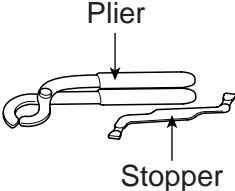
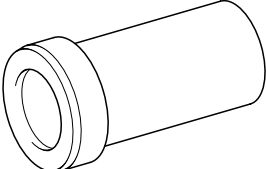

## SPECIAL TOOLS

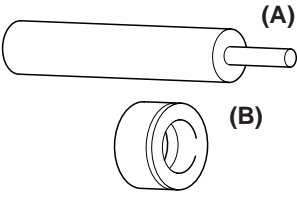
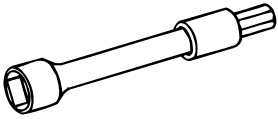
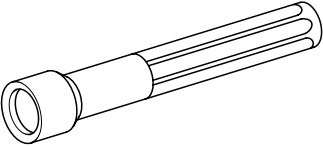
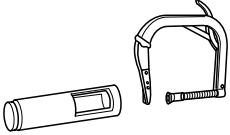
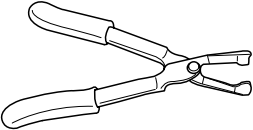
Tool (number and name)	Illustration	Use
Crankshaft front oil seal installer (09214-32000)	 <p style="text-align: right;">L4GC006A</p>	Installation of front oil seal
Crankshaft front oil seal guide (09214-32100)	 <p style="text-align: right;">L4GC007A</p>	Installation of front oil seal
Removal and installation of mounting bushing (09216-22000)	 <p style="text-align: right;">L4GC008A</p>	Removal and installation of engine mounting bushing (Use with 09216-22100)
Valve clearance adjusting tool (09220-2D000)	 <p style="text-align: right;">L4GC009A</p>	Removal and installation of mechanical tappet shim
Camshaft oil seal installer (09221-21000)	 <p style="text-align: right;">L4GC010A</p>	Installation of camshaft oil seal

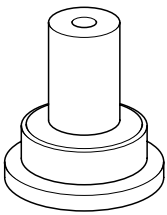
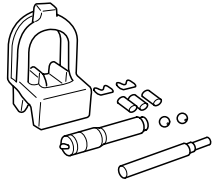
Tool (number and name)	Illustration	Use
Valve guide installer (09221-22000(A/B))	 <p style="text-align: right;">L4GC011A</p>	Removal and installation of valve guide
Cylinder head bolt wrench (09221-32001)	 <p style="text-align: right;">L4GC012A</p>	Removal and tightening of cylinder head bolt
Valve stem oil seal installer (09222-22001)	 <p style="text-align: right;">L4GC013A</p>	Installation of valve stem oil seal
Valve spring compressor holder and adaptor (09222-28000, 09222-28100)	 <p style="text-align: right;">L4GC014A</p>	Removal and installation of piston pin (Use with 09234-33003)
Valve stem seal remover (09222-29000)	 <p style="text-align: right;">L4GC015A</p>	Removal of valve stem seal

Tool (number and name)	Illustration	Use
Crankshaft rear oil seal installer (09231-21000)	 L4GC016A	1. Installation of engine rear oil seal 2. Installation of crankshaft rear oil seal
Piston pin removal and installation kit (09234-33001)	 L4GC017A	Removal and installation of intake and exhaust valve (Use with 09222-29000)
Piston pin setting tool insert (09234-33003)	 L4GC018A	Removal and installation of piston pin (Use with 09234-33001)

## TROUBLESHOOTING

Symptom	Possible cause	Remedy
Low compression	Cylinder head gasket damaged Worn or damaged piston ring Worn piston or cylinder Worn or damaged valve seat	Replace gasket Replace ring Repair or replace piston and cylinder block Repair or replace valve and seat ring
Low oil pressure	Insufficient engine oil Oil pressure switch defective Oil filter clogged Worn oil pump gear or cover Thin or diluted engine oil Oil relief valve clogged(Open) Excessive bearing clearance	Check engine oil level Replace oil pressure switch Install new filter Replace Replace engine oil Replace or inspect Replace bearing
High oil pressure	Oil relief valve clogged(Closed)	Repair relief valve
Noisy valve	Thin or diluted engine oil Faulty HLA Worn belt stem or valve guide	Replace engine oil Replace HLA Replace belt stem or valve guide
Noisy connecting rod or timing belt	Insufficient engine oil Low oil pressure Thin or diluted engine oil Excessive bearing clearance	Check engine oil level Refer to “too low oil pressure” Replace engine oil Replace bearing
Noisy timing belt	Incorrect belt tension	Correct belt tension
Low coolant level	Coolant leak from Heater or radiator hose Defective radiator cap Thermostat housing Radiator Water pump	Repair or replace parts Retighten clamp or replace Replace gasket or housing Replace Replace parts
Radiator clogged	Foreign material into coolant	Replace coolant
Abnormally high coolant temperature	Thermostat defective Radiator cap defective Abnormal flow in cooling system Loose or missing driving belt Loose water pump Water temperature wiring defective Cooling pan defective Radiator or thermostat switch defective Inefficient coolant	Replace parts Replace parts Clean or replace parts Correct or replace Replace Repair or replace Repair or replace Replace Add coolant

Symptom	Possible cause	Remedy
Abnormally low coolant temperature	Thermostat defective	Replace
	Water wiring defective	Repair or replace
Oil cooling system leak	Loose connecting part	Retighten
	Cracked or damaged hose, pipe, and oil cooler	Replace
Exhaust gas leak	Loose connecting part	Retighten
	Pipe or muffler damaged	Repair or replace
Abnormal noise	Breakaway exhaust plate in muffler	Replace
	Rubber hanger damaged	Replace
	Pipe or muffler with body Interfered	Repair
	Pipe or muffler damaged	Repair or replace
	Catalytic converter damaged	Replace
	Each connecting gasket damaged	Replace

## SERVICE AND ADJUSTING PROCEDURE

### CHECKING ENGINE OIL

1. Be sure that the oil is between “F” and “L” marks of the dipstick.

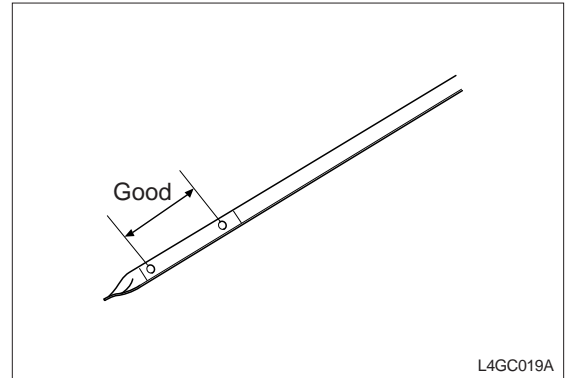

2. If the oil level is below “L” mark, add about 1L of oil.
3. Check contamination and viscosity of the engine oil and replace it if necessary.

### CHECKING COMPRESSED PRESSURE

1. Prior to inspection, check that the engine oil, starter motor and battery are normal.
2. Start the engine and run it until the engine coolant temperature reaches 80 ~ 95°C).
3. Stop the engine and disconnect the spark plug cable and air cleaner element.
4. Remove the spark plug.
5. After opening the throttle valve completely, crank the engine to remove foreign material from the cylinder.

#### CAUTION

- ***At this time, necessarily screen the spark plug hole with a rag. Because hot coolant, oil, fuel, and other foreign material, being penetrated in the cylinder through cracks can come into the spark hole during checking compressed pressure.***
  - ***When cranking the engine to test compressed pressure, necessarily open the throttle valve before cranking.***
6. Install the compression gauge to the spark plug hole.

7. With the throttle valve opened, crank the engine to measure the compressed pressure.

Standard(250~400rpm)	Standard	15kg/cm <sup>2</sup>
	Limit	14kg/cm <sup>2</sup>

8. Follow the procedures (no.6-7) to each cylinder and check that compressed pressure values of all cylinders are within the limit.

<b>Limit</b>	1.0kg/cm <sup>2</sup>
--------------	-----------------------

9. If any of all cylinders is out of limit, add a small amount of engine oil to the spark plug hole, and re-proceed the procedures (no.6-7) to the cylinder.

At this time, if the compressed pressure is increased, it means that the piston, piston ring or cylinder surface are worn or damaged, and if the compressed pressure is decreased, it means that the valve is clogged, the valve contact is faulty, or the pressure leaks through gasket.

**⚠ CAUTION**

***If a large amount of incomplete combustion gasoline comes into the catalytic converter, emergency such as a fire can occur due to overheating. So this job should be done quickly with the engine not operated.***

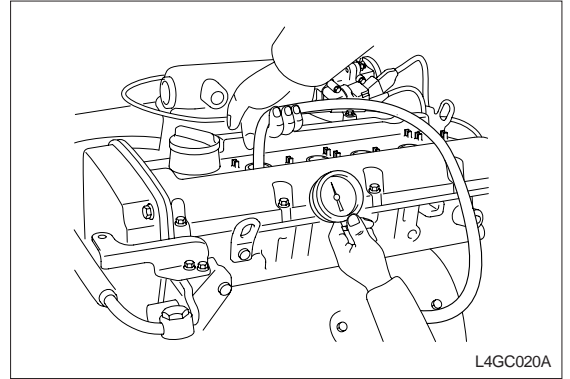

## ADJUSTING TIMING BELT TENSION

Adjust the tension as the following order.

1. Turn the steering wheel completely counterclockwise.
2. While the engine oil pan is supported with a wooden block, raise the vehicle using a jack.

**⚠ CAUTION**

***At this time carefully raise the vehicle not to overload parts.***

3. Remove the pan drive tension pulley.
4. Loosen the timing belt upper cover bolt(B) and disconnect the upper cover(A).

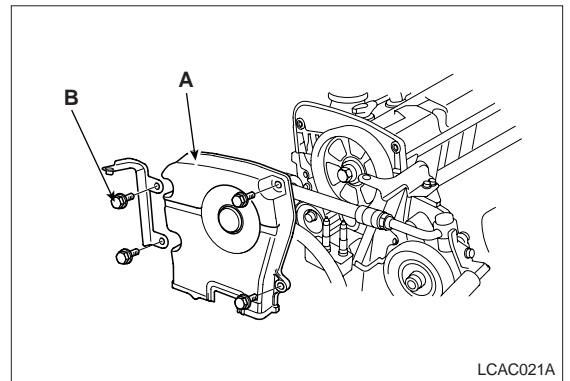

5. As the illustration, insert the hex wrench to the adjuster groove and turn it counterclockwise to move the arm indicator in the middle of the base groove.

**⚠ CAUTION**

***If it is turned in reverse direction, be sure that the tensioner may function abnormally.***

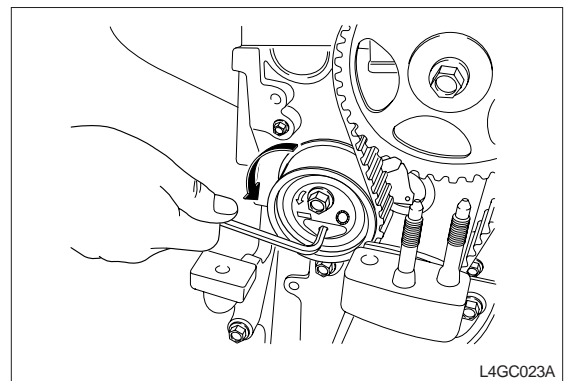

6. Tighten the tensioner fixing bolt with the arm indicator fixed.

<b>Tightening torque</b>	2.3~2.9kgf·m
--------------------------	--------------

7. Rotate the crankshaft 2 turns clockwise and make sure the auto tensioner arm indicator is placed in the middle of the base groove.
8. If the arm indicator is out of the middle, loosen the bolt and repeat the previous procedure.
9. Install the timing belt upper cover(A) and tighten the bolt (B).

<b>Tightening torque</b>	0.8~1.0kg·m
--------------------------	-------------

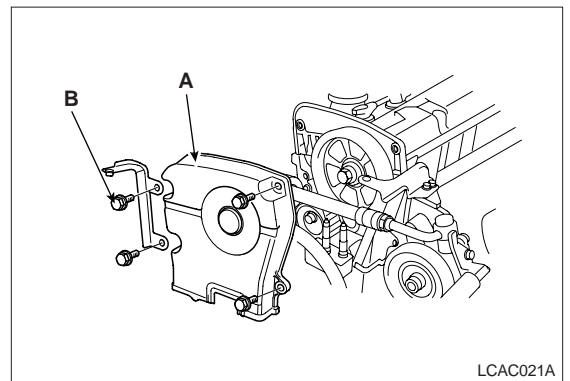



## TROUBLESHOOTING

### 1. Checking coolant leaks

- 1) After the coolant temperature drops below 38°C loosen the radiator cap.
- 2) Check that the coolant level reaches filler neck.
- 3) Install the radiator cap tester to the radiator filler neck and apply a pressure of 1.4kg/cm<sup>2</sup> .  
While maintaining it for 2 minutes, check the radiator, hose, and connecting part for leak.

 **CAUTION**

- ***Because the coolant in the radiator is too hot, never open the cap when it hot, or injury may occur due to an outburst of hot water.***
- ***Dry out the inspection part.***
- ***When removing the tester, take care not to spill the coolant.***
- ***When removing/installing the tester as well as testing, take care not to deform the filler neck.***

- 4) Replace parts if leak is detected.

### 2. Density test

- 1) Measure density of the coolant using a hydrometer.
- 2) After measuring the coolant temperature, calculate density using the following table of temperature and density.

### 3. Temperature and density of coolant

Temperature and density of coolant (Temp.:°C)					Freezing point(°C)	Normal operating temperature(°C)	Coolant temperature
10	20	30	40	50			
1.054	1.050	1.046	1.042	1.036	-16	-16	30%
1.063	1.058	1.054	1.049	1.044	-20	-20	35%
1.071	1.067	1.062	1.057	1.052	-25	-25	40%
1.079	1.074	1.069	1.064	1.058	-30	-30	45%
1.087	1.082	1.076	1.070	1.064	-36	-36	50%
1.095	1.090	1.084	1.077	1.070	-42	-42	55%
1.103	1.098	1.092	1.084	1.076	-50	-50	60%

**⚠ CAUTION**

- *If the coolant contains less than 30% of antifreeze, anticorrosion is decreased.*
- *If the coolant contains more than 60% of antifreeze, the engine will be fatally affected, resulting from decreased anti-freezing and engine cooling.*

*Use only the recommended antifreeze and do not mix with other production.*

## 4. Recommended antifreeze

Recommended antifreeze	Ethylene glycol
------------------------	-----------------

## CHECKING AND ADJUSTING DRIVE BELT TENSION

## 1. Checking tension

- 1) Press the middle of the water pump pulley and alternator pulley with 10Kg.f.
- 2) Inspect the belt deflection by pressing it.
- 3) If the belt deflection is out of the standard, adjust it as follows.

Item	Standard	
	New belt	Used belt
Drive belt deflection (L)	4.0~4.4mm	5.1~5.7mm

2. Using a tension gauge

1) Type

- ① BORROUGHS BT - 33 - 73F
- ② NIPPONDENSO BTG - 2

2) How to use

- ① Insert the belt between the gauge hook and spindle and press the tension gauge handle.
- ② Leave the handle and read the gauge.

Tension(T)	Standard	
	New belt	Used belt
	65~75kg	40~50kg

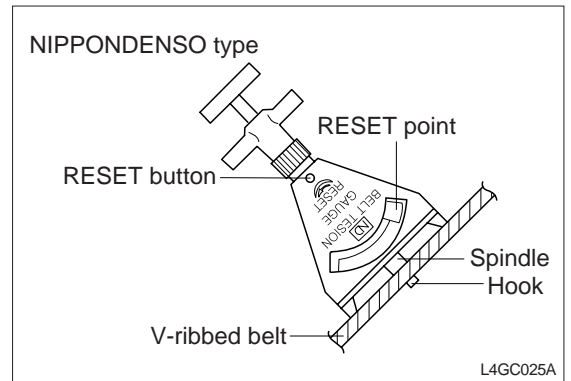
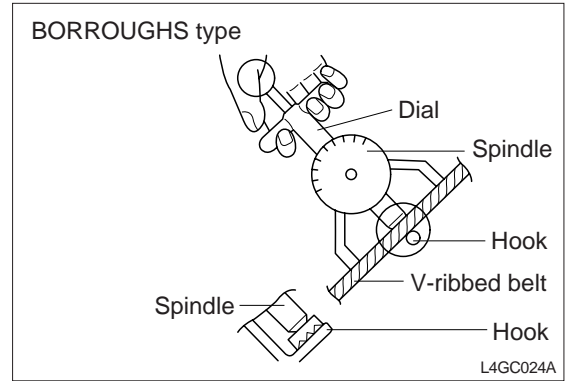

**CAUTION**

- *The belt used over 5 minutes should be adjusted as used belt of standard.*
- *Check that the belt is installed correctly.*
- *When the belt is loosened, slip noise is heard.*

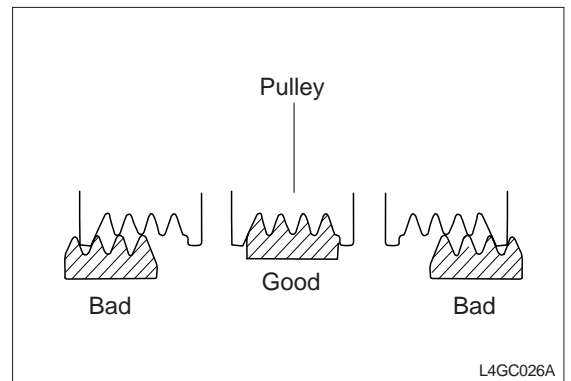

**ADJUSTING**

1. Loosen the alternator support bolt "A" nut and adjusting lock bolt "B" .
2. Adjust the belt tension by moving the alternator brace adjusting bolt to "T" direction.

Alternator adjusting lock bolt "B"	1.2~1.5kg·m
Alternator support bolt "A"	2~2.5kg·m

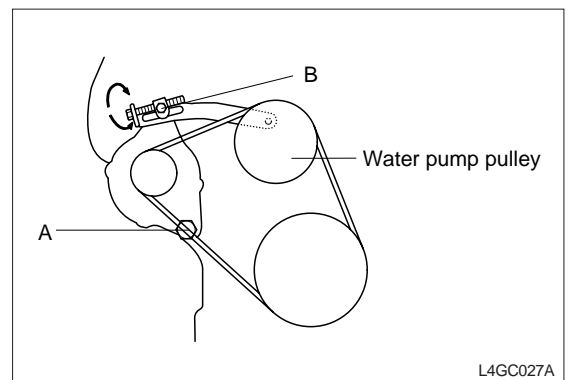

- Tighten the bolt "A" and then tighten "B" to the specified torque.

 **CAUTION**

- If the belt tension is too excessive, noise as well as early wear of belt occurs and the water pump bearing and alternator bearing are damaged.*
- If the belt is too loose, due to early wear of belt and insufficient power of alternator, battery and water pump become inefficient and finally engine is overheated or damaged.*

### CHECKING BELT FOR DAMAGE

Check the following items and replace the belt if defective.

- Check the belt surface for damage, wear and crack.
- Check the belt surface for oil or grease contamination.
- Check the rubber part for wear or hardening.
- Check the pulley surface for crack or damage.

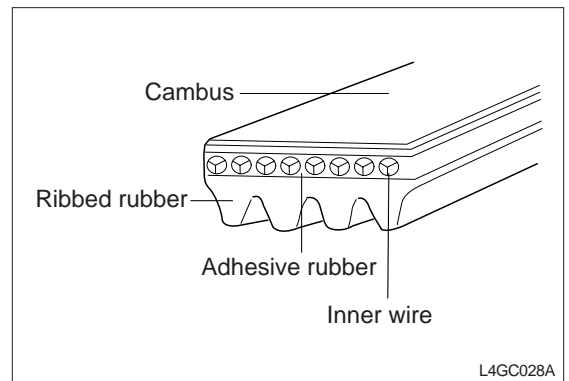

## CYLINDER BLOCK

### COMPONENTS

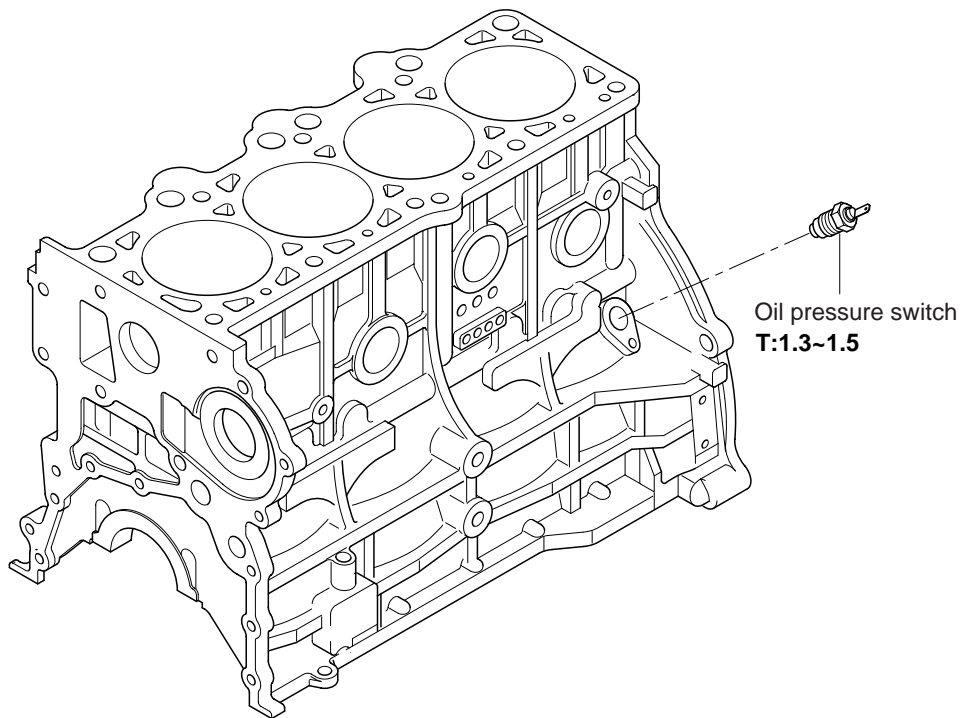

**Tightening torque: kg·m**

L4GC029A

### REMOVAL

1. Remove the cylinder head, timing belt, front case, flywheel and piston.
2. Remove the oil pressure switch.

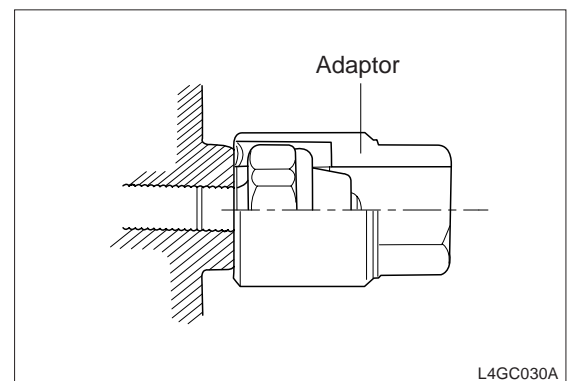

L4GC030A

**INSPECTION**

**CYLINDER BLOCK**

1. Inspect the cylinder block for scratch, fur and rust visually, check for invisible crack or other deformation using a proper tool and repair or replace if necessary.
2. Measure flatness of the cylinder block upper surface using a straight edge and a thickness gauge. When measuring, the cylinder block upper surface should be flat without a fragment.

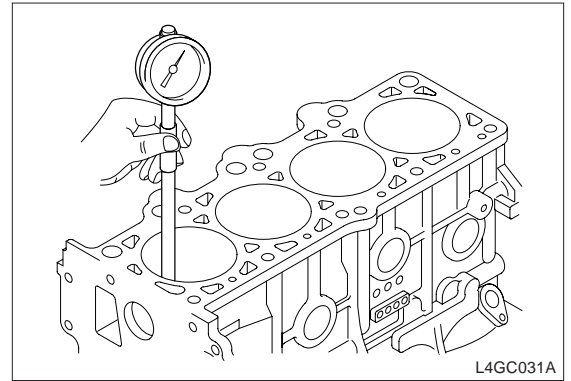

Flatness	0.03mm or less
Parallelism	0.15mm or less

3. Measure the cylinder bore towards A and B directions at 3-point height using a cylinder gauge. If the cylinder bore is larger than standard and the cylinder wall is scratched or furred excessively, bore and hone the cylinder block and install a new oversize piston and ring.

Cylinder I.D	82.00 ~ 82.03mm
Cylinder I.D cylindricity	0.01mm

4. If the top ridge is partially worn, cut it with a ridge reamer.
5. There are 4 kinds of oversize piston.

Items	Size
0.25 OS	0.25mm
0.50 OS	0.50mm
0.75 OS	0.75mm
1.00 OS	1.00mm

6. To bore the cylinder bore to the oversize, maintain the clearance between oversize piston and bore and use the same size of pistons. When measuring the piston O.D, measure flatness of the skirt thrust surface at 47mm below from the piston top land.

Clearance between piston and cylinder	0.02 ~ 0.04mm
---------------------------------------	---------------

**INSTALLATION**

Install the following parts in order.

1. Crankshaft
2. Flywheel
3. Piston
4. Cylinder head

FRONT CASE, OIL PUMP

COMPONENTS

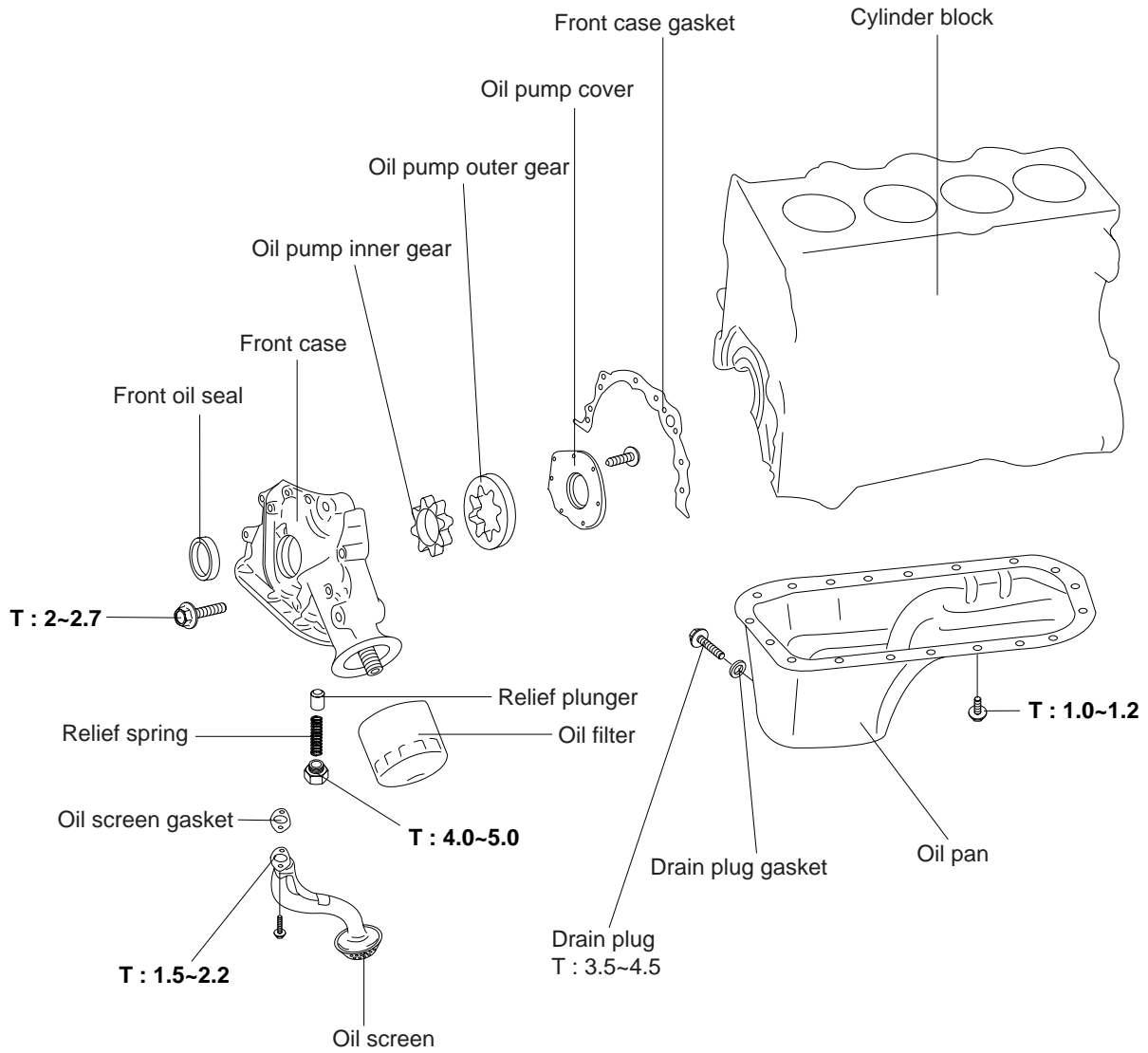

Tightening torque: kg·m



## REMOVAL

1. Remove the timing belt.
2. Remove all oil pan tightening bolts.
3. Separate the oil pan from the cylinder block by tapping on the oil pan with a rubber hammer and then remove the oil pan.

**NOTE**

*If the oil pan is raised by a screwdriver, it can be deformed.*

4. Remove the oil screen.
5. Remove the front case assembly.
6. Remove the oil pump cover.
7. Remove the inner and outer gears from the front case.
8. Remove the plug and then remove the relief spring and relief valve.

## INSPECTION

### FRONT CASE

1. Check the front case for crack and damage and replace if necessary.
2. Check the front oil seal for wear and damage and replace it defective.

### OIL SEAL AND OIL SCREEN

1. Check the oil pan for defect, damage and crack and replace if necessary.
2. Check the oil screen for defect, damage and crack and replace if necessary.

### FRONT CASE AND OIL PUMP COVER

Check the gear contact surface for wear (especially a partial wear) and damage.

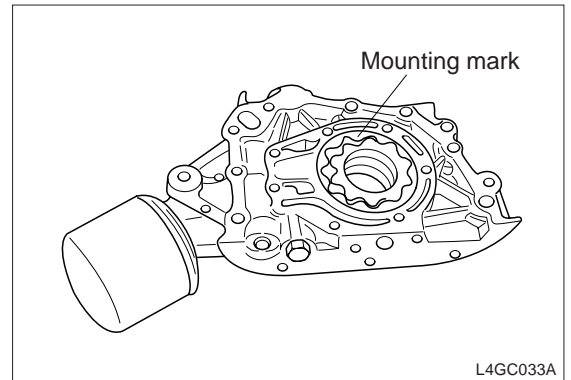

**OIL PUMP GEAR**

1. Check the gear tooth surface for wear and damage.
2. Measure clearance between the outer gear and front case.

Item		Standard
Body clearance		0.12 ~ 0.185mm
Tip clearance		0.025 ~ 0.069mm
Side clearance	Outer gear	0.04 ~ 0.09mm
	Inner gear	0.04 ~ 0.085mm

3. Check clearance between the outer gear tooth end and inner gear tooth end.

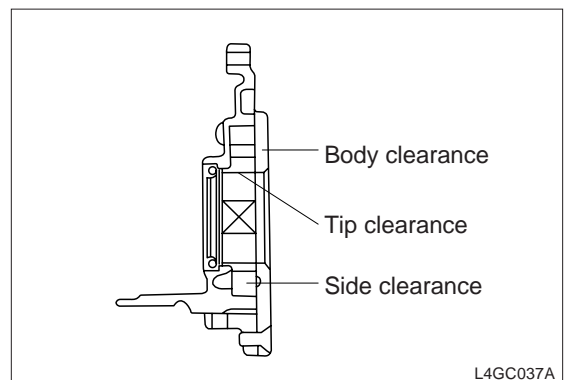
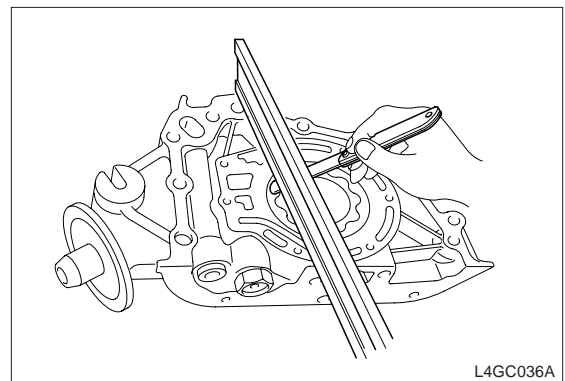
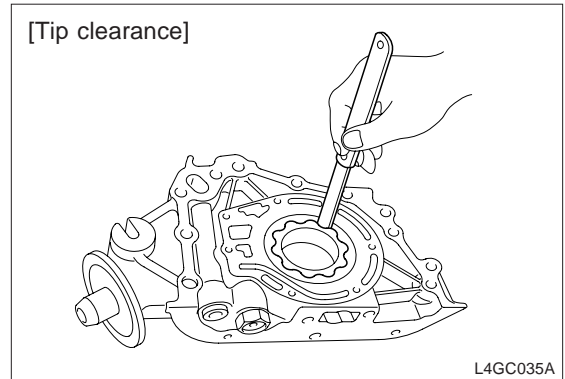
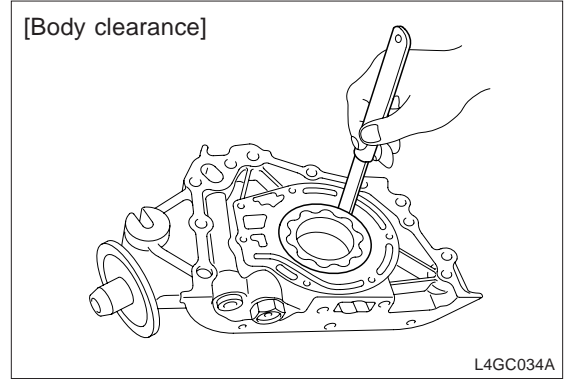

**RELIEF VALVE AND SPRING**

1. Check the relief valve inserted in the front case for perturbation.
2. Check the relief spring for deformation or damage.

Free height	43.8mm
Load	3.7kg/40.1mm

**INSTALLATION****OIL PUMP**

1. Install the outer and inner gears to the front case.
2. After installing the oil pump cover, tighten the bolt to the specified torque. After tightening the bolt, check that the gear rotates smoothly.

Oil pump cover bolt	0.6 ~ 0.9kg·m
---------------------	---------------

3. Install the relief valve and spring and after tightening the plug to the specified torque, apply engine oil to the relief valve.

Relief valve plug	4.0 ~ 5.0kg·m
-------------------	---------------

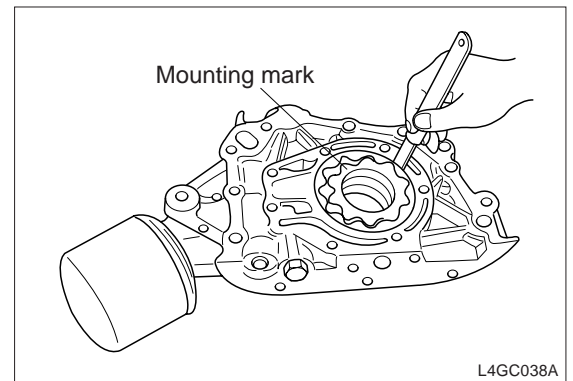

**FRONT CASE**

1. Install the gasket and front case assembly and tighten the bolt to the specified torque.

Items		Values
Bolt length	A	25mm
	B	20mm
	C	45mm
	D	38mm
Specified torque		2.0 ~ 2.7kg·m

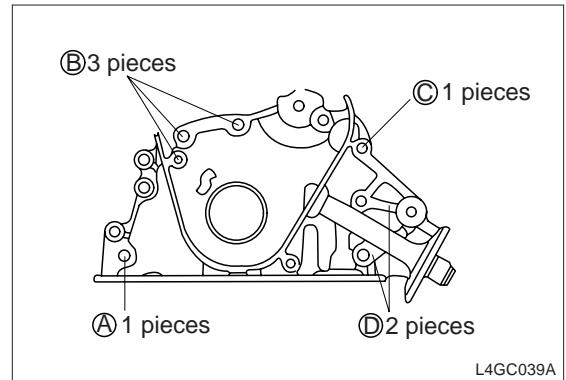

**OIL SEAL**

1. Install the special tool “crankshaft oil seal guide(09214-32100)” to the front end of the crankshaft. After applying engine oil to the outer surface of the oil seal guide, insert a new oil seal through the guide until it reaches the front case by hand.

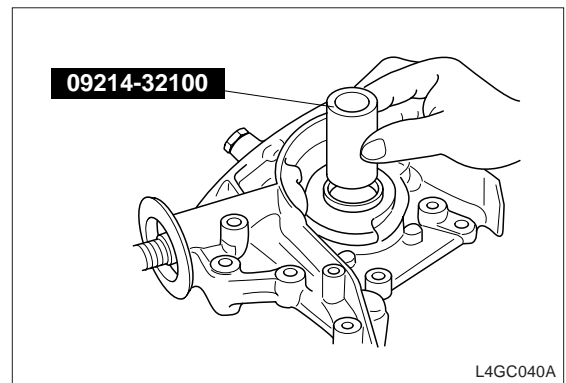

2. Install the oil seal using the special tool “crankshaft oil seal installer(09214-32000)” (in parallel with front case).

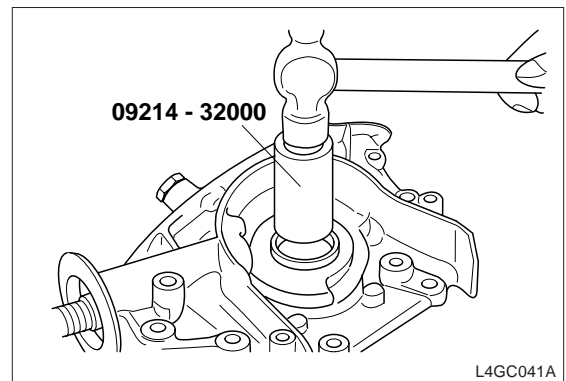

3. Install the crankshaft sprocket, timing belt, and crankshaft pulley.
4. Install the oil screen.
5. Refer to “oil pan gasket and cylinder block gasket”.
6. Apply sealant to the oil pan flange groove as shown in the illustration.

**CAUTION**

**Apply sealant as a thickness of about  $\Phi 4\text{mm}$ .  
Before 15 minutes is passed after applying sealant,  
install the oil pan.**

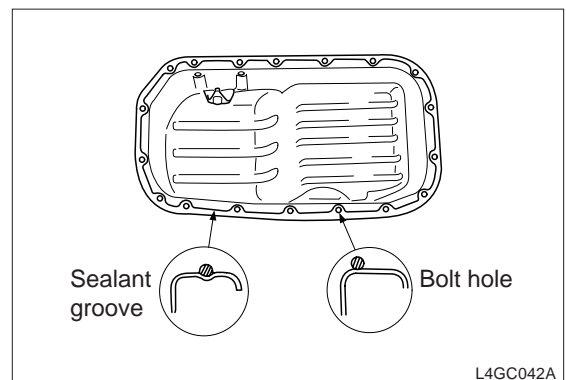

7. Install the oil pan and tighten the bolt to the specified torque.

Oil pan bolt	1.0 ~ 1.2kg·m
--------------	---------------

MAIN MOVING SYSTEM

CAMSHAFT, HLA, TIMING CHAIN, CHAIN GUIDE

COMPONENTS

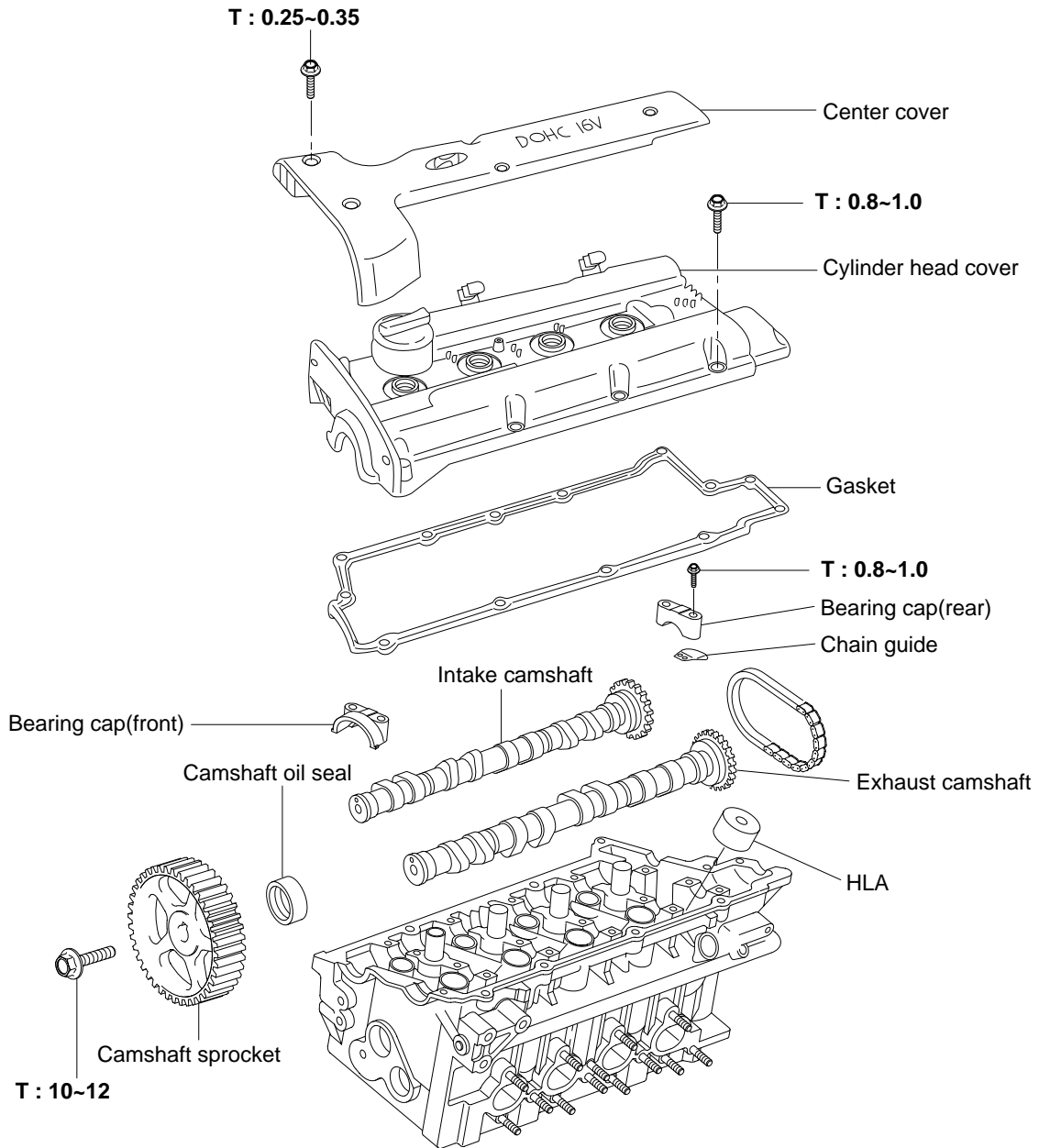

Tightening torque : kg·m

**REMOVAL**

1. Remove the breeder hose and P.C.V hose.
2. Remove the center cover.
3. Remove the ignition coil and spark plug.
4. Remove the timing belt upper cover.

5. Remove the cylinder head cover.

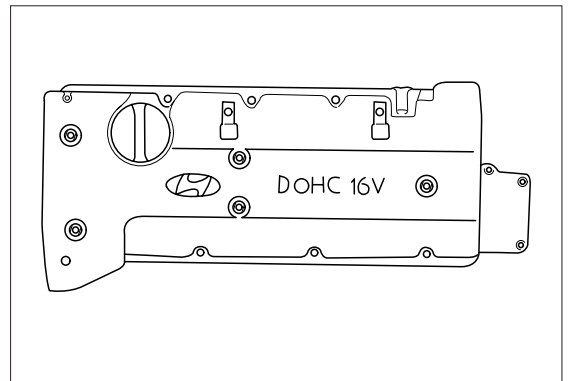

6. Remove the tensioner.
7. Loosen the camshaft sprocket bolt and remove the camshaft sprocket.
8. Loosen the bearing cap bolt and after removing the bearing cap, remove the camshaft.

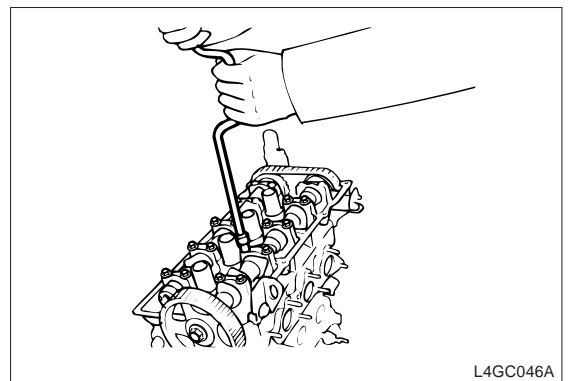

9. Remove the timing chain.
10. Remove the HLA.

**INSPECTION**

**CAMSHAFT**

1. Check the camshaft journal for wear and if the journal is seriously worn, replace the camshaft.
2. Check the cam lobe for damage and if the lobe is severely damaged or worn, replace the camshaft.

Items		Standard	Limit
Cam height	Intake	43	42.9
	Exhaust	43	42.9

3. Check the cam surface for abnormal wear and damage and replace it if necessary.
4. Check the cylinder head camshaft journal for damage and if the surface is severely damaged, replace the cylinder head assembly.
5. Lightly put the camshaft on the cylinder head as shown in the illustration and after installing a dial gauge towards shaft, check the endplay.

Camshaft endplay	0.1 ~ 0.2mm
------------------	-------------

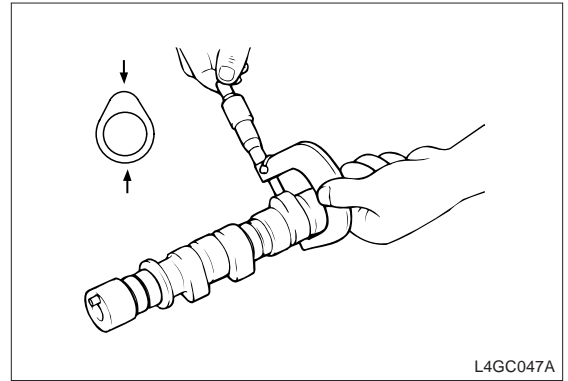

**OIL SEAL**

1. Check the oil seal surface for wear and if the seal lip portion is worn, replace it.
2. Check the camshaft oil seal lip contact surface for partial wear and replace it if necessary.

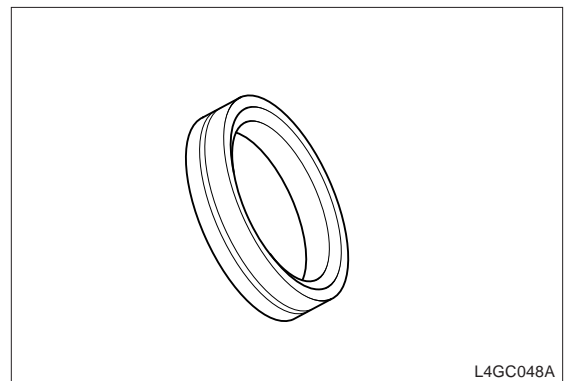

**HLA(Hydraulic Lash Adjuster)**

1. HLA I.D :  $\phi 33(-0.025/-0.041)$
2. How to remove noise when it heard from valve
  - 1) Prior to engine warm-up, check that the engine oil level is normal.
  - 2) Warm-up the engine.
  - 3) If the valve noise is heard at engine warm-up, air-bleed the system.
  - 4) How to air-bleed
    - a) During remaining it for 10 minutes at 3,000 rpm and over 5 minutes at idle, check that the valve noise is heard.
    - b) Repeat the above step(a) only once or twice.



- 5) If the valve noise is still heard after following the above step 4), replace the hydraulic lash adjuster(HLA) which makes noise.
- 6) If the valve noise is heard after replacing parts, necessarily repeat the above step 4).
- 7) After air-bleeding the system and replacing parts to remove noise, if the valve noise is re-heard 2-3 days after, it might be affected from defective HLA, so replace the defective HLA.

**NOTE**

*In case of the vehicle with HLA, when initially starting the engine, it is normal if valve noise is momentarily heard.*

**CAUTION**

- 1) *Because HLA is precision parts, take care not to come foreign materials such as a dust from outside.*
- 2) *Do not disassemble HLA.*
- 3) *When cleaning HLA, use clean diesel oil.*
- 4) *Take care not to make scratches and sharp edges to O.D of HLA.*
- 5) *With HLA filled with engine oil, grasp A and press B by hand as shown in the illustration, if the HLA is moving, replace the HLA.*

3. Loosen the center cover bolt and remove the center cover.
4. Remove the oil filler cap.

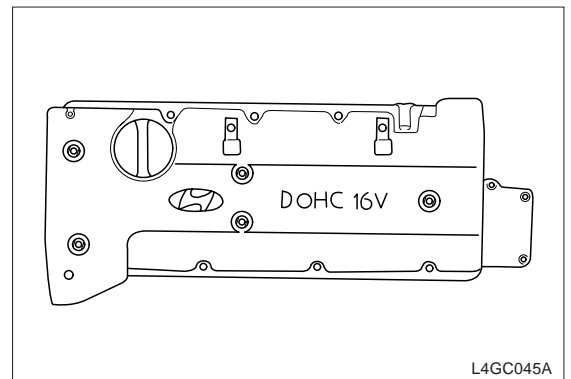
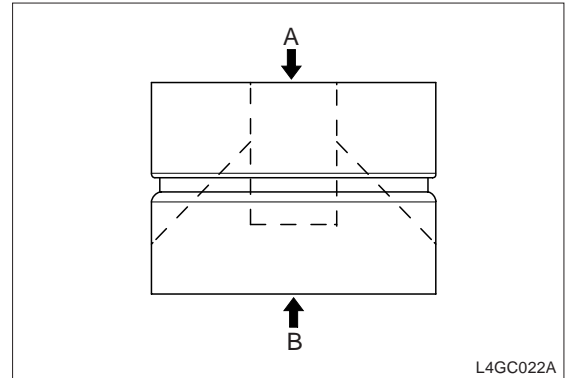

5. Remove the timing belt upper cover.

6. Remove the cylinder head cover.
  - 1) Disconnect the spark plug cable.
  - 2) Disconnect the PCV hose and intake hose.
  - 3) Disconnect the accelerator cable.
  - 4) Remove the cylinder head cover and gasket.
  
7. Place the cylinder no.1 to the dead point.
  - 1) Rotate the crankshaft pulley so as to align it with "T" mark on the timing belt low cover.

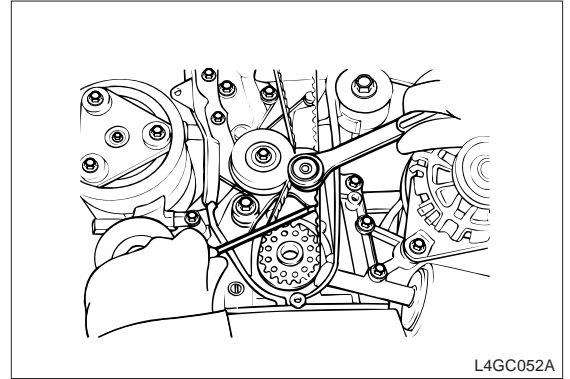

- 2) Check that the camshaft timing pulley hole is aligned with timing mark on the bearing cap. If it is not aligned, readjust it by rotate the crankshaft to 360° .

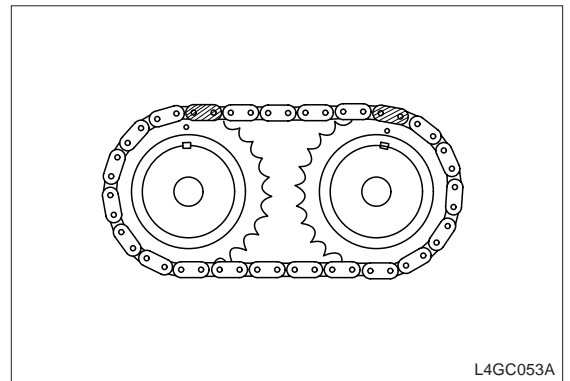

## 6. Check the valve gap.

- 1) Measure the gap between the camshaft and valve lift using a gauge.

**Valve gap (Engine coolant temperature : 20°)**

Intake	0.12 ~ 0.28mm
Exhaust	0.20 ~ 0.36mm

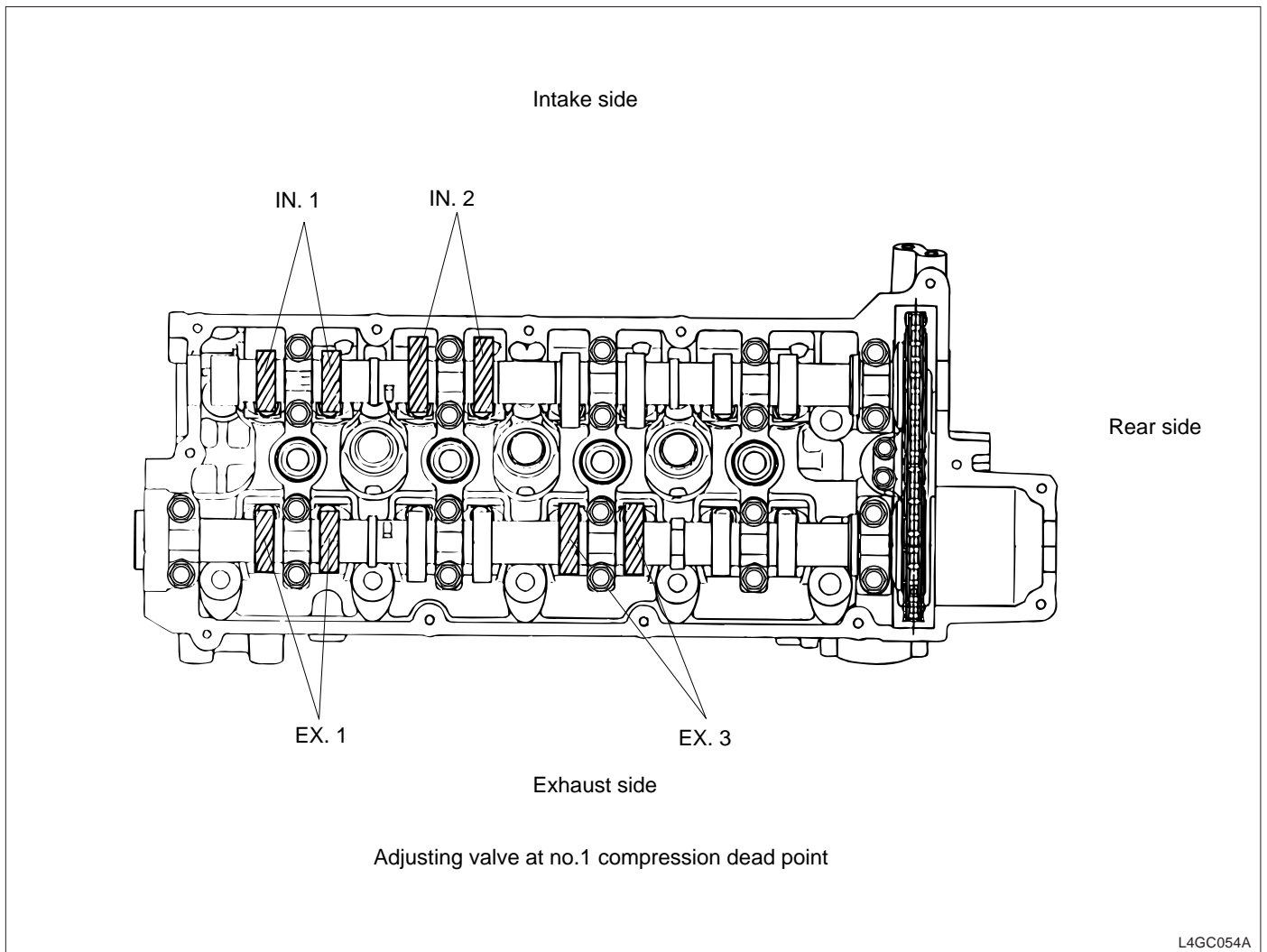

- 2) Rotate the crankshaft pulley so as to align it with "T" mark on the timing belt low cover.
- 3) Check the valve gap.

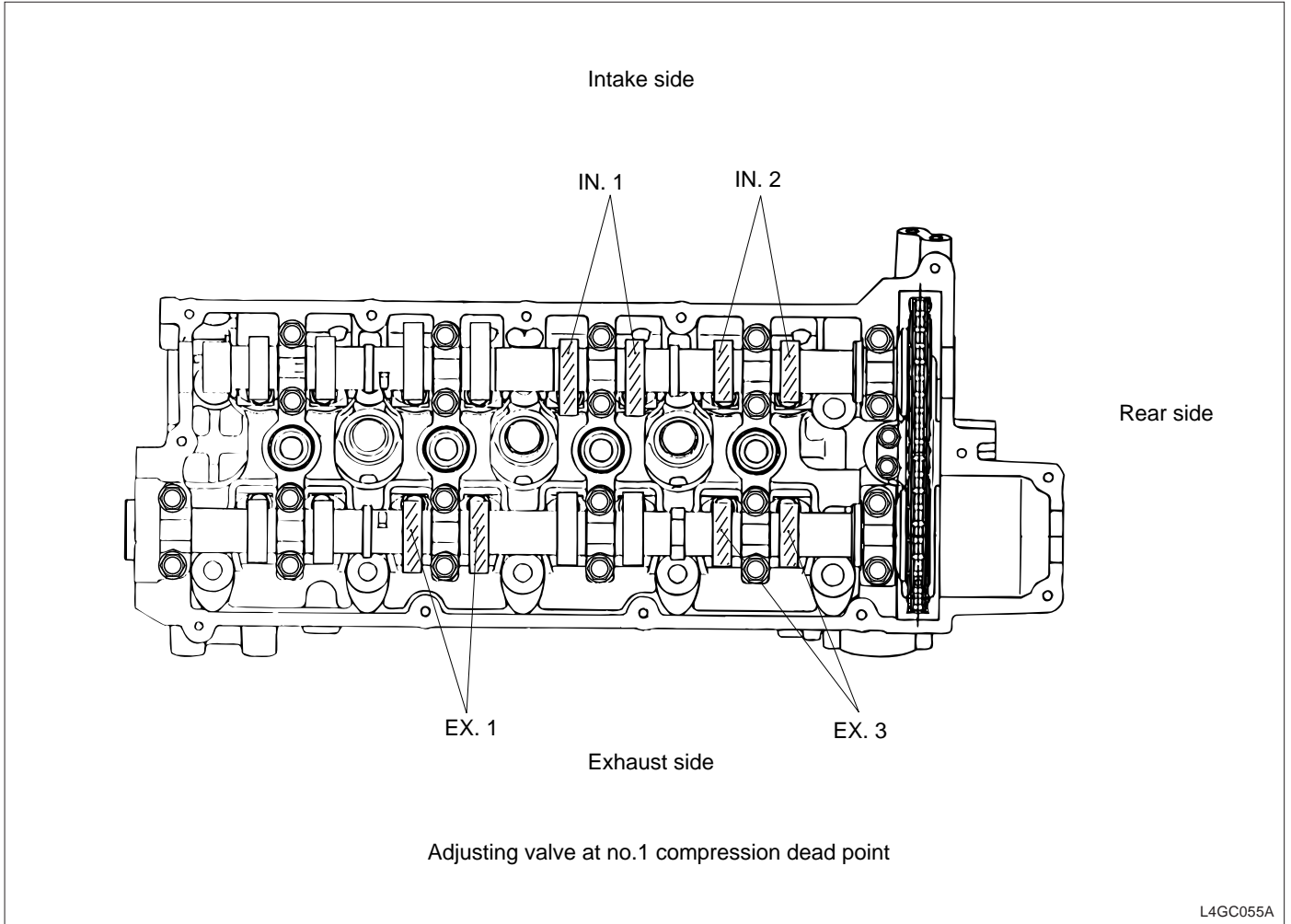

7. Adjust the gap between the intake and exhaust valves.

- 1) Rotate the crankshaft so as to place the cam lobe on the adjustable valve camshaft upward.

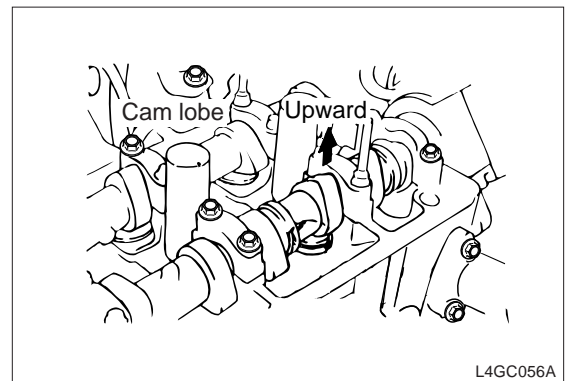

- 2) Using the special tool(09222-2D000), press the valve lifter downward and install the stopper between the cam shaft and valve lifter.

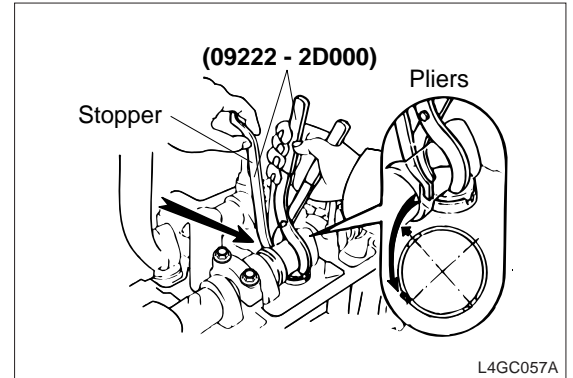

- 3) Remove the adjusting shim using a small screwdriver and a magnet.

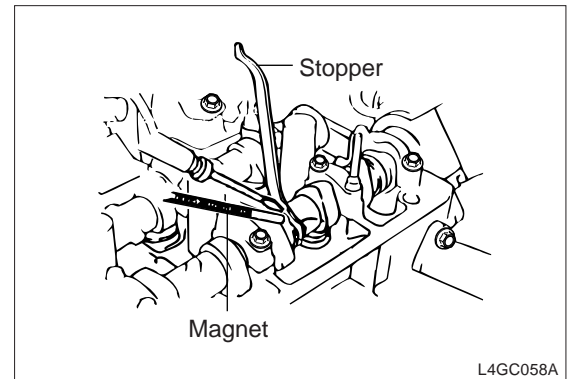

- 4) Using a micrometer, measure thickness of the removed shim.

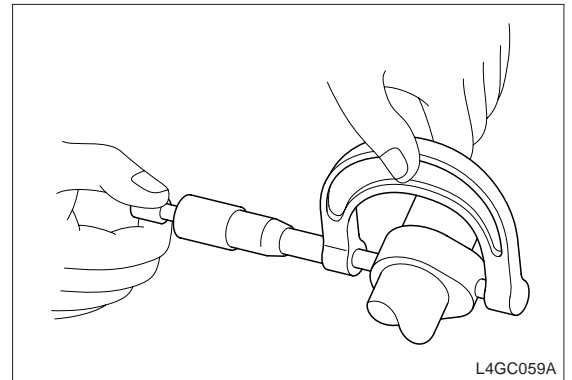

- 5) Calculate thickness of new shim to be valve gap within the specified value.

T: Thickness of removed shim

A: Measured valve gap

N: Thickness of new shim

Intake :  $N=T+(A-0.20\text{mm})$

Exhaust :  $N=T+(A-0.28\text{mm})$

**NOTE**

*There are 20 shims up to 2.0mm at intervals of 0.04mm.*

- 6) Install a new adjusting shim.
- 7) After measuring the valve gap, check that it is within the specified values.

**Valve gap (Engine coolant temperature: 20°)**

Intake	0.12 ~ 0.28mm
Exhaust	0.20 ~ 0.36mm

**REASSEMBLY**

1. After cleaning sealant remnants of the cylinder head and cylinder head cover, apply new sealant(LOCTITE NO.5999).

** CAUTION**

***Don't apply sealant too much, to prevent it from coming out.***

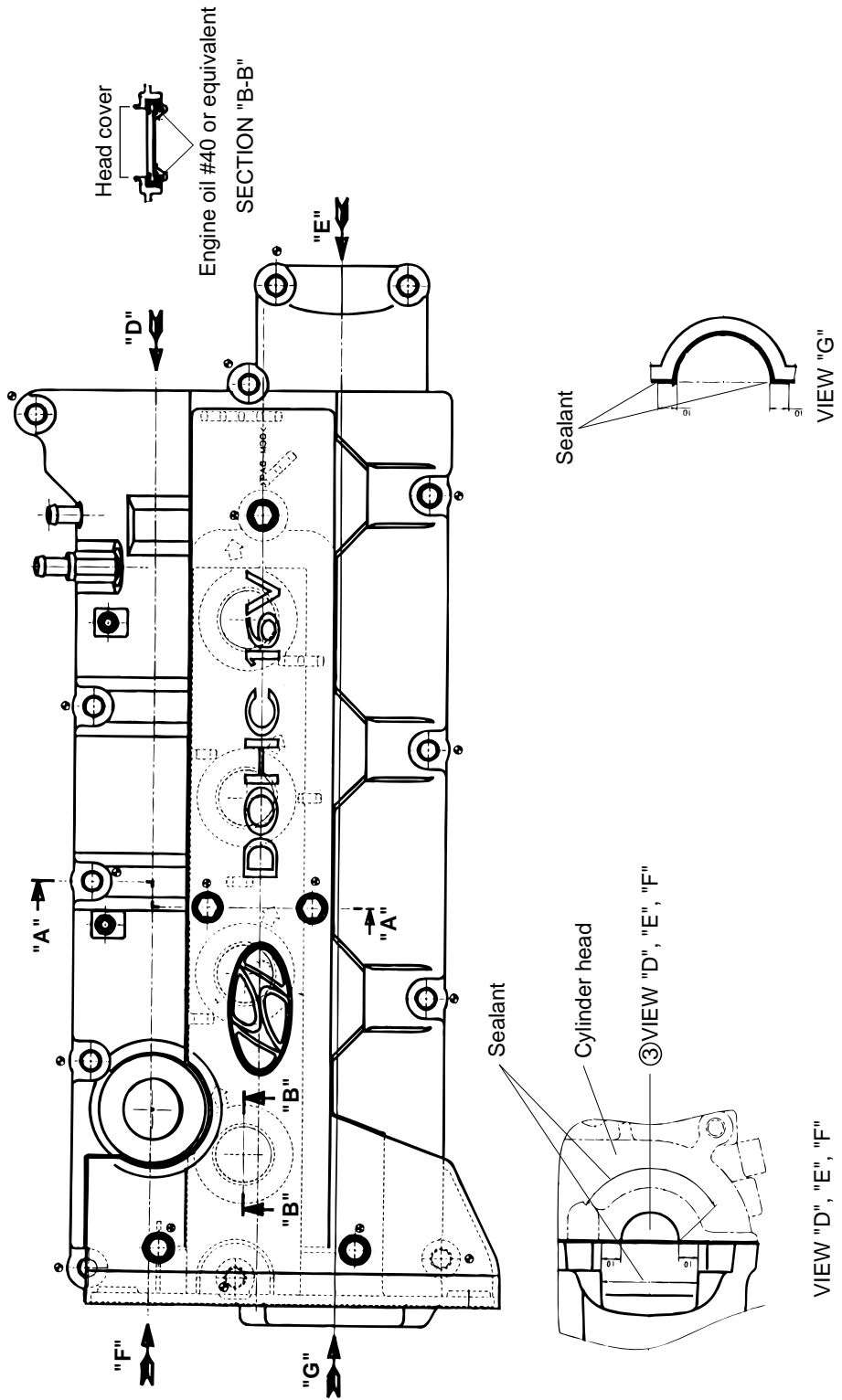

2. Install the cylinder head cover.

Cylinder head cover	0.8 ~ 1.0kg·m
---------------------	---------------

3. Connect the accelerator cable.  
4. Connect the PCV hose and intake hose to the head cover.  
5. Connect the spark plug cable.  
6. Install the timing belt upper cover.  
7. Install the center cover.

Center cover	0.25 ~ 0.35kg·m
--------------	-----------------



4. Timing chain

- 1) Check the timing chain bushing and plate portion for wear and if those are severely worn, replace those.

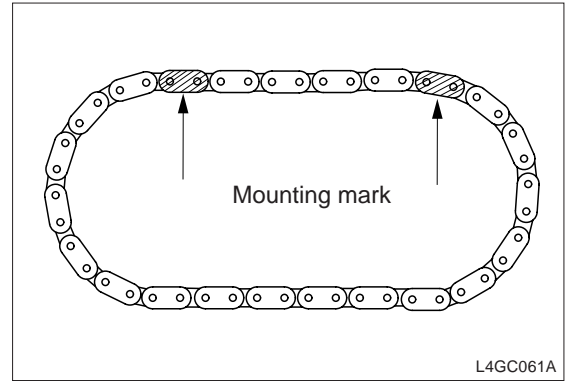

INSTALLATION

1. Install HLA

**CAUTION**  
*Tappet and shim should be installed to the original position.*

2. After Installing the intake and exhaust camshaft by aligning it with the timing mark on the timing chain sprocket, install the camshaft to the cylinder head.

**CAUTION**

- *Apply engine oil to the camshaft journal and cam.*
- *There a detective pin for TDC sensor in the intake camshaft rear end and a dowel pin in the intake camshaft front end.*

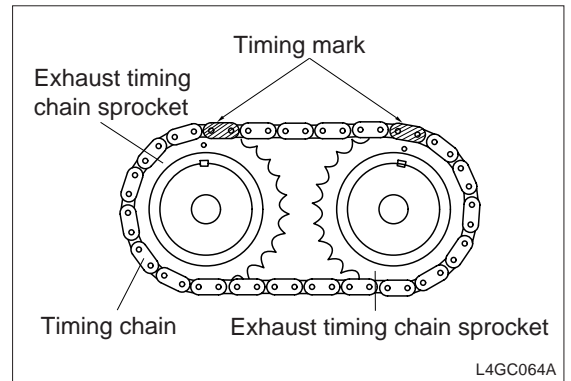

3. Install the camshaft cap.

Check the intake and exhaust identification marks.(Check cap number and arrow and take care not to change the bearing cap position and direction.)

I: Intake camshaft

E: Exhaust camshaft

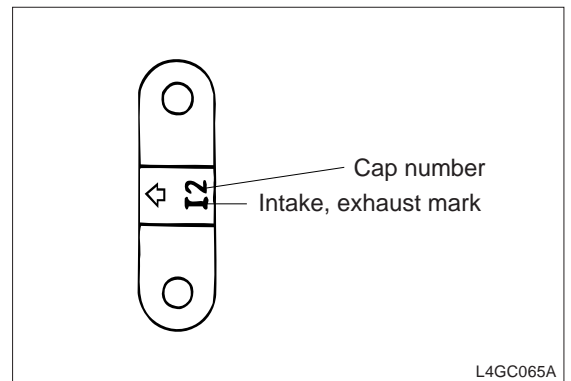

- Check that the camshaft is smoothly turned by hand.  
After checking, remove the bearing cap and camshaft and install MLA.
- Check that the dowel pin on the exhaust camshaft sprocket is installed upward.

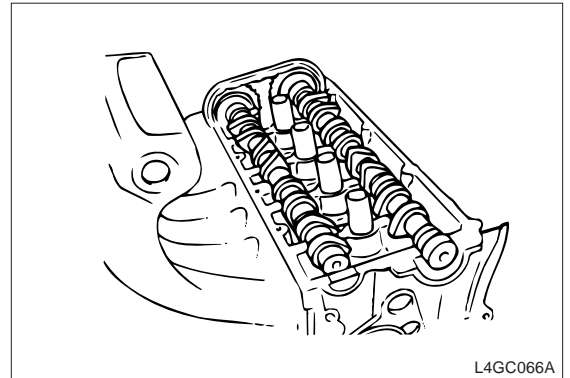

- Tighten the bearing cap to the specified torque by tightening bolts 2-3 times as shown in the illustration.

Bearing cap bolt	1.4 ~ 1.5kg·m
------------------	---------------

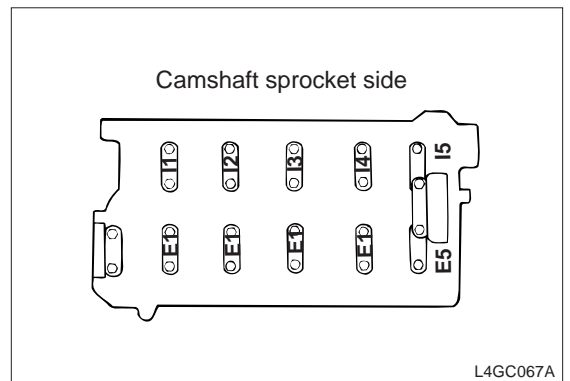

- Using the special tool "camshaft oil seal installer and guide", press the camshaft oil seal. Necessarily apply engine oil to the oil seal lip. Insert the oil seal through the camshaft front end and install it by tapping on the installer with a hammer until the oil seal reaches 8.5mm from the camshaft front end.

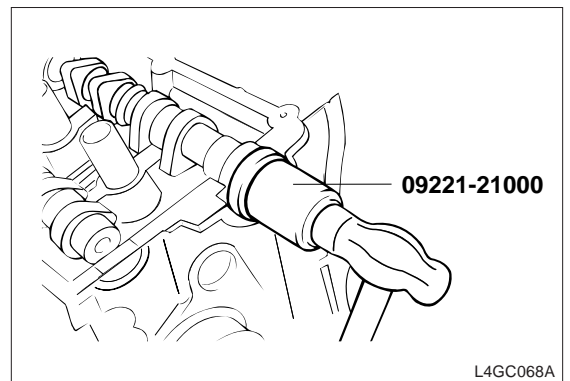

- Install the camshaft sprocket to the specified torque.

Camshaft sprocket bolt	10 ~ 12kg·m
------------------------	-------------



**CAUTION**

**Align the timing marks on the camshaft sprocket and the crankshaft sprocket. At this time piston no. 1 cylinder should be placed on the compression dead point.**

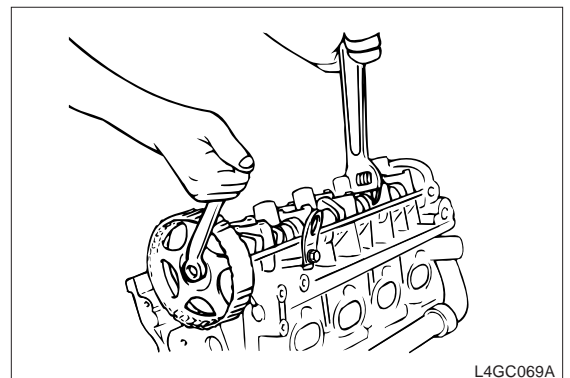

9. Install the cylinder head cover. Apply sealant as shown in the illustration.

Cylinder head cover	0.8 ~ 1.0kg·m
---------------------	---------------

Apply engine oil to the oil seal lip to help install the cylinder head cover oil seal to the spark plug pipe smoothly.

**CAUTION**

- **Necessarily tighten the cylinder head cover bolt to the specified torque.**  
*If it is tightened too much, the head cover can be deformed resulting in oil leaks and the head cover bolt can be broken resulting in cylinder head replacement.*
- **When installing after head cover removing, necessarily apply sealant to the head cover rear and front portion.**
- **Because the head cover is made of plastic, take care not to drop tools on the head cover upper portion when removing/installing the engine parts.**
- **When installing after head cover removing, after checking the head gasket for damage, reuse it if it is normal.**
- **When applying/draining engine oil, take care not to spill oil on the head cover upper surface, if oil is spilled, wipe it out completely with a paper and a rag.**

10. Install the timing belt.

11. Install the timing belt cover.

Cylinder head cover	0.8 ~ 1.0kg·m
---------------------	---------------

12. Install the spark plug center cover.

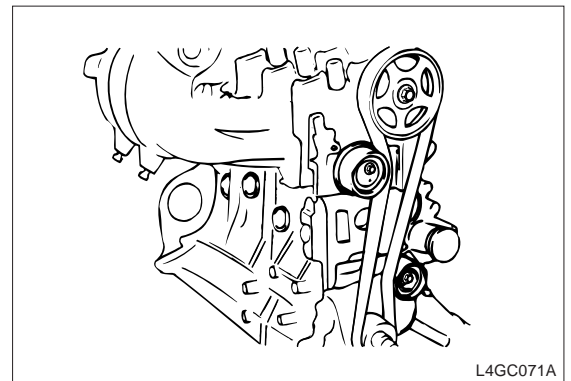
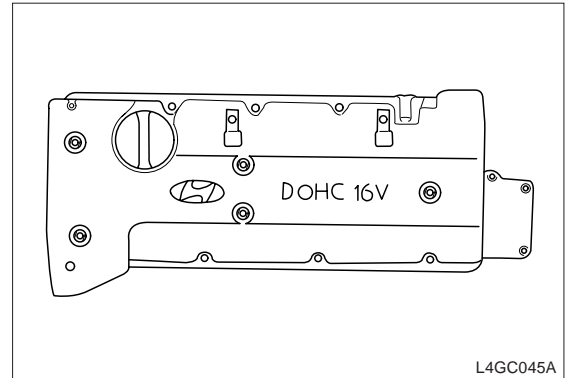

CRANKSHAFT

COMPONENTS

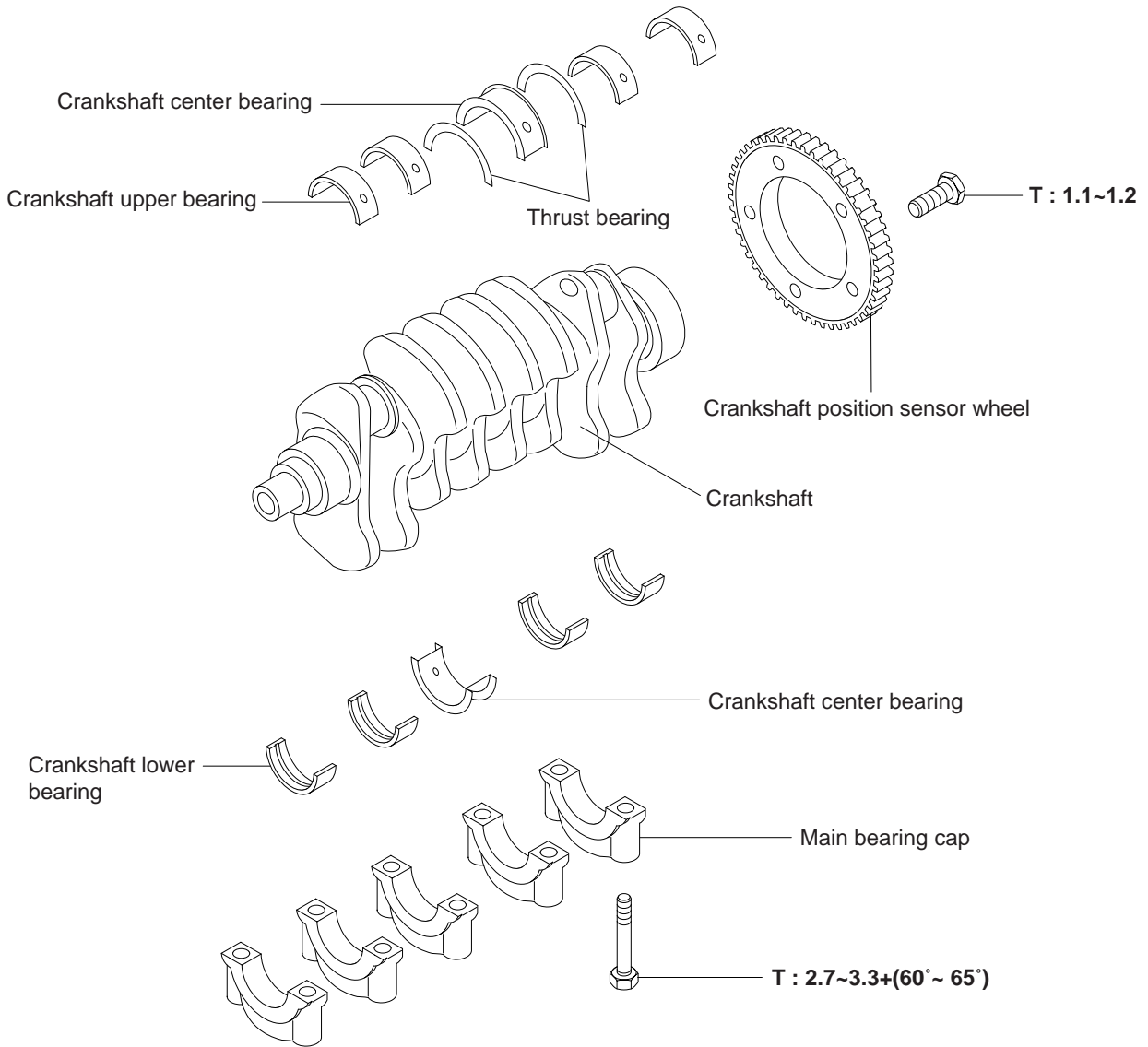

Tightening torque : kg·m

## DISASSEMBLY

1. Remove the timing belt train, front case, flywheel, cylinder head assembly, and oil pan.
2. Remove the rear plate and rear oil seal.
3. Disconnect the connecting rod cap.
4. Remove the main bearing cap. (Arrange it in order)
5. Remove the crankshaft.
6. Disassemble the crankshaft position sensor wheel.



### **NOTE**

***Put an identification mark on the main bearing cap to refer to the original position and direction.***

## INSPECTION

1. Crankshaft
  - 1) Check the oil hoe for clogging as well as crankshaft journal pin for damage, uneven wear and crack. Repair or replace parts if necessary.
  - 2) Inspect “out of circularity” of the crankshaft journal taper and pin.

Crankshaft journal O.D	57mm
Crank pin O.D	45mm
Out of circularity of crankshaft journal pin	0.01mm or less

2. Main bearing and connecting rod bearing  
Visually inspect each bearing for scratch, melting, sticking, and fault contact and replace the bearing if necessary.

3. Measuring oil clearance

- 1) Measure O.D of the crankshaft journal and pin.
- 2) Measure diameter of the crankshaft bore and connecting rod bore.
- 3) Measure the thickness of the crankshaft and connecting rod bearing.
- 4) Calculate clearance by subtracting O.D of the journal pin and thickness of the bearing from diameter of the bore.

Journal oil clearance	0.028 ~ 0.048mm
Pin oil clearance	0.024 ~ 0.044mm

Main bearing cap bolt	2.7 ~ 3.3kg·m+(60° ~ 65° )
Connecting rod cap bolt	5.0 ~ 5.3kg·m

4. Oil seal

Check the front and rear oil seal and replace it with new parts if necessary.

**ASSEMBLY**

1. After checking the sensor wheel for damage and crack, replace it if necessary.
2. Inspect the clearance between the sensor wheel and crank position sensor.

Clearance between sensor wheel and crank position sensor	0.5 ~ 1.1mm
--	-------------

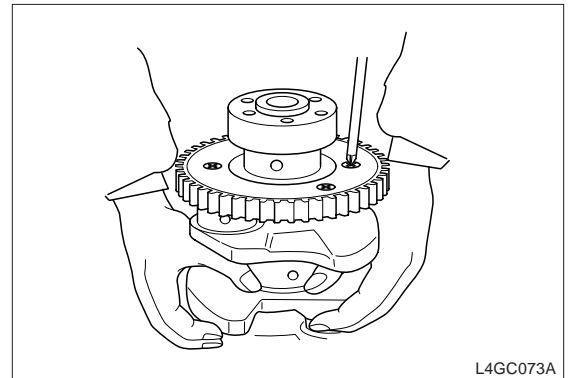

If the clearance is out of specified values, check the sensor wheel for balancing and the crank position sensor for installation and replace those if necessary.

**CAUTION**

**Sensor wheel as one of the electronic control affects performance if deformed or damaged, so be careful when handling it.**

3. Install the upper main bearing to the cylinder block. When reusing the main bearing, refer to the identification mark during assembly.
4. Install the bearing shaft and apply engine oil to the journal and pin.

5. Install the bearing cap and tighten the cap bolt to the specified torque from the center in order.  
(Tighten the bearing cap bolts to the specified torque by tightening bolts step by step 2-3 times equally)

Main bearing cap bolt	2.7 ~ 3.3kg·m+(60° ~ 65° )
Connecting rod cap bolt	5.0 ~ 5.3kg·m

When installing the cap, proper number of cap should be installed as well as arrow mark should be directed to the engine crank pulley.

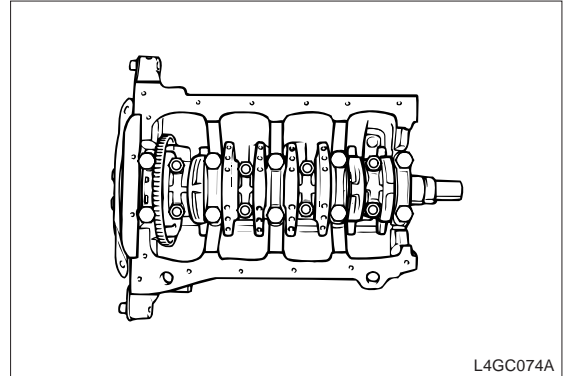

6. Check that the crankshaft for free rotation and proper clearance between the center main bearing thrust flange and connecting rod big-end bearing.

Crankshaft end-play	0.06 ~ 0.260mm
---------------------	----------------

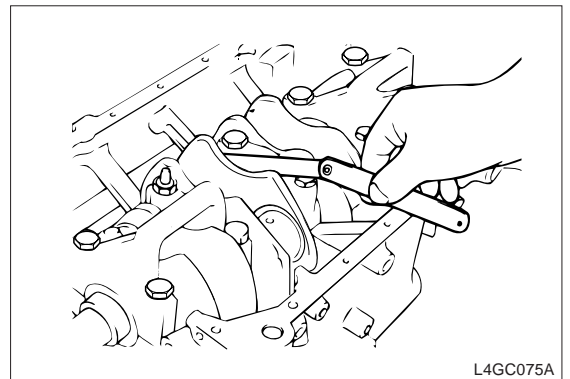

7. Using the special tool “Crankshaft oil seal installer (09231-21000)”, fully insert the oil seal into the crankshaft rear oil seal case.

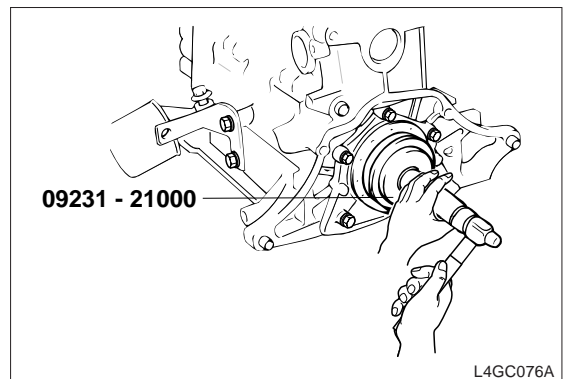

8. Install the rear oil seal case and gasket and tighten 5 bolts.  
When installing, apply engine oil to the oil seal round and crankshaft.
9. Install the rear plate.
10. Install the flywheel, front case, oil pan, and timing belt train.

FLYWHEEL & HOUSING

COMPONENTS

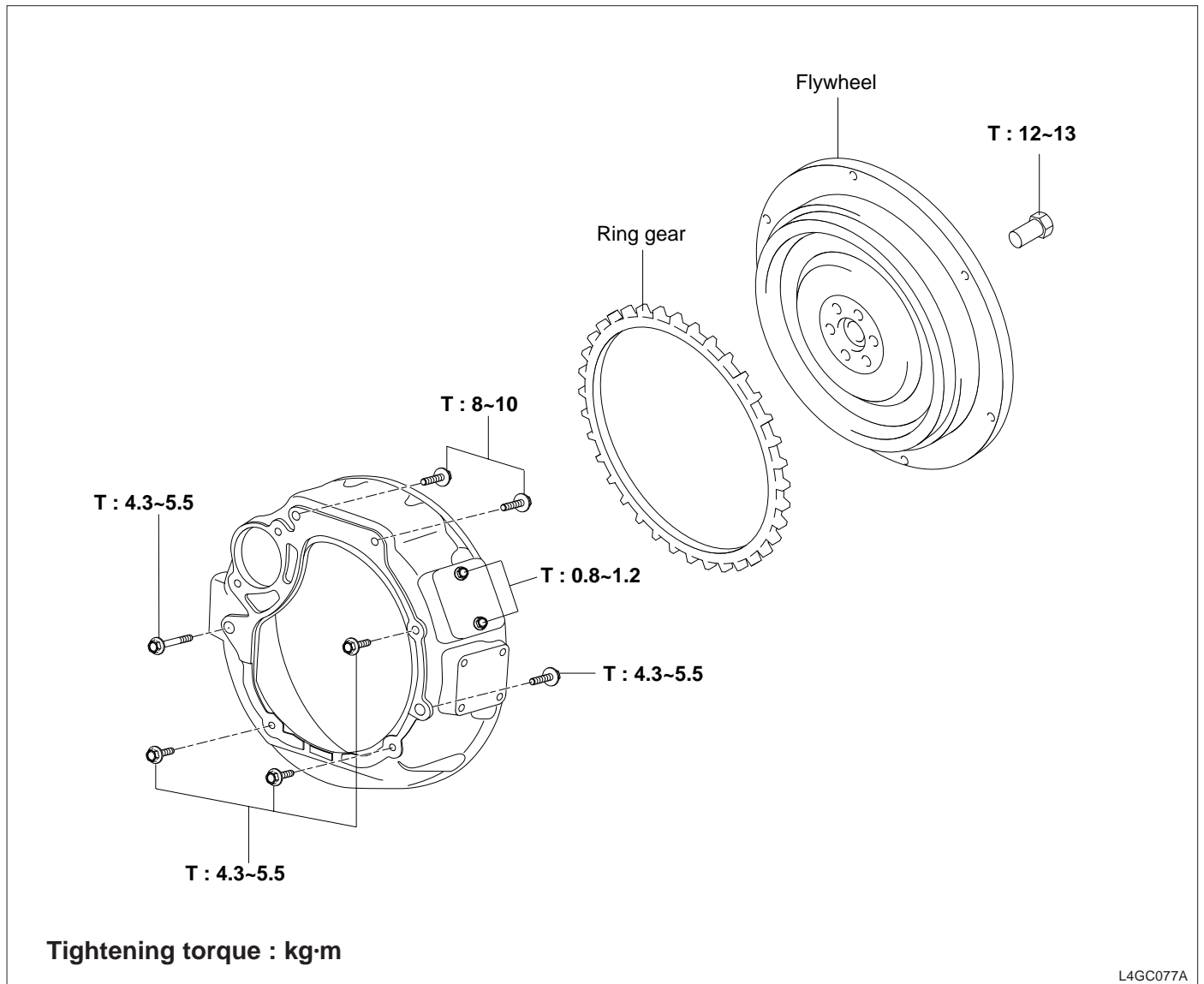

REMOVAL

1. Remove the flywheel.
2. Remove the flywheel housing.



**INSPECTION**

1. Check the ring gear for damage and crack and replace it if necessary.

**ASSEMBLY**

1. Install the flywheel housing and tighten the bolt to the specified torque.
2. Install the flywheel assembly and tighten the bolt to the specified torque.

Flywheel bolt	12 ~ 13kg·m
---------------	-------------

PISTON AND CONNECTING ROD

COMPONENTS

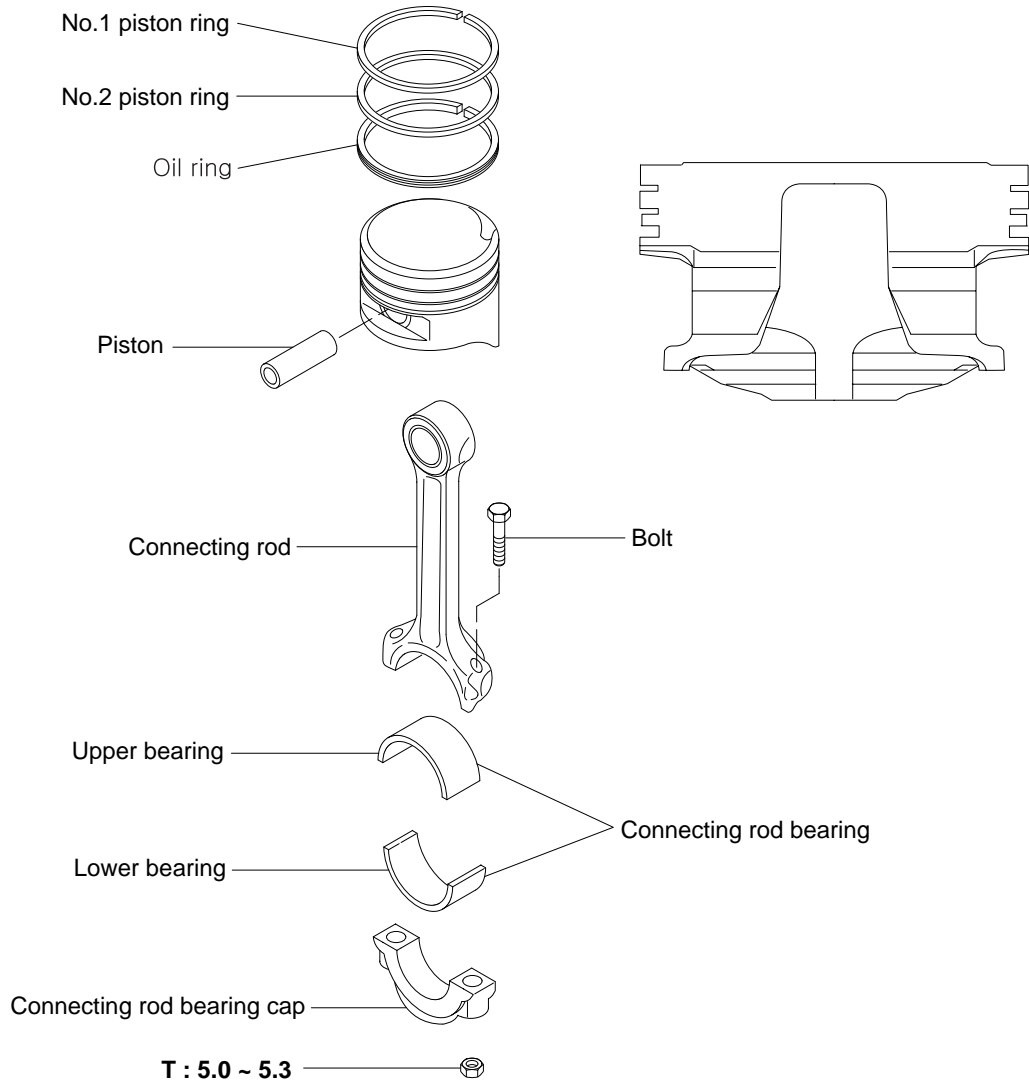

Tightening torque : kg·m

**DISASSEMBLY**

1. Remove the cylinder head assembly.



**NOTE**  
*Put an identification mark on the connecting rod and cap before disassembly to refer to the original position and direction.*

2. Remove the oil pan and remove the oil screen.
3. After removing the connecting rod cap, remove the piston and connecting rod assembly from the cylinder. Arrange the connecting rod bearing in cylinder number order.
4. Using the special tool “piston pin setting tool (09234-33001)”, disassemble the piston from the connecting rod as below.
  - 1) Remove the piston ring.
  - 2) When placing the assembly on a press, face the front mark on the piston upward.
  - 3) Using the press, remove the piston pin.

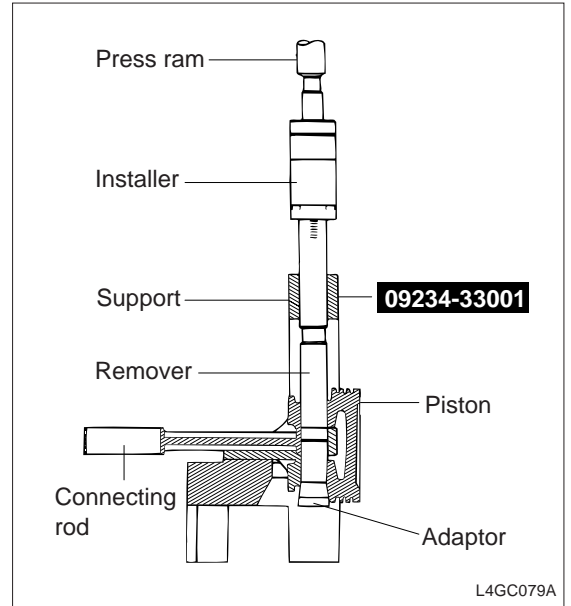

**INSPECTION**

**PISTON AND PISTON PIN**

1. Check the piston for scratch, wear, etc. and replace it if necessary.
2. Check the piston ring for break, damage and abnormal wear and replace it if necessary. When replacing the piston, the ring should be replaced also.
3. Check that the piston pin is inserted in the piston hole and replace the piston and pin if necessary.  
 Piston should be smoothly pressed at normal room temperature.

**PISTON RING**

1. When measuring the side clearance of piston ring, if the measured value is out of the limit, insert a new ring to the ring groove and re-measure the side clearance.

Item		Specified value	Limit
Side clearance of piston ring	No.1	0.04 ~ 0.08mm	0.1mm
	No. 2	0.03 ~ 0.07mm	0.1mm

- To measure the end gap of piston ring, insert the piston ring to the cylinder bore. At this time, smoothly insert the ring to the piston so as to place the ring and cylinder wall to right position.

After this, smoothly insert the ring to the piston.

And then, pull out the piston upward and measure gap using a feeler gauge. When the gap exceeds the limit, replace the piston ring.

Item	Specified value	Limit
No.1 piston ring end gap	0.23 ~ 0.38	1mm
No.2 piston ring end gap	0.33 ~ 0.48	1mm
Oil ring end gap	0.20 ~ 0.60	1mm

When just replacing the ring without correction of cylinder bore, place the ring to the cylinder lower part where less worn-out and measure the gap.

When replacing the ring, use the same size of ring.

Item	Mark
	STD
Piston ring over size	0.25mm OS
	0.50mm OS
	0.75mm OS
	1.00mm OS

**NOTE**

*Size mark is placed on the top of the ring.*

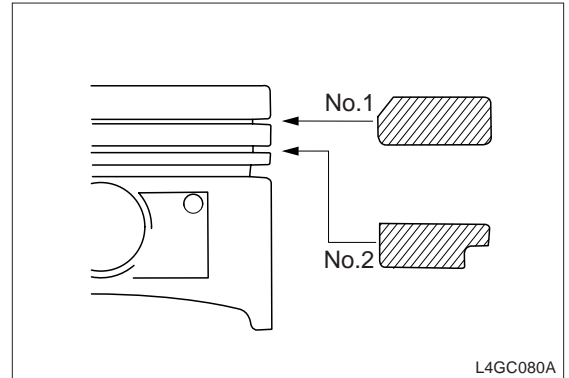

**CONNECTING ROD**

- When installing the connecting rod cap, refer to the cylinder numbers on the rod end cap which are marked during disassembly.  
When installing a new connecting rod, align the bearing with the notch.
- If both end thrust surfaces of the connecting rod are damaged, partially worn, or the inside of small end is too rough, replace the connecting rod.

3. Using a connecting rod aligner, measure bending and torsion of rod and if the measured value is around the limit, correct the rod with a press.

But when the rod is severely bended or damaged, necessarily replace it.

Bending of connecting rod	0.05mm
Torsion of connecting rod	0.1mm

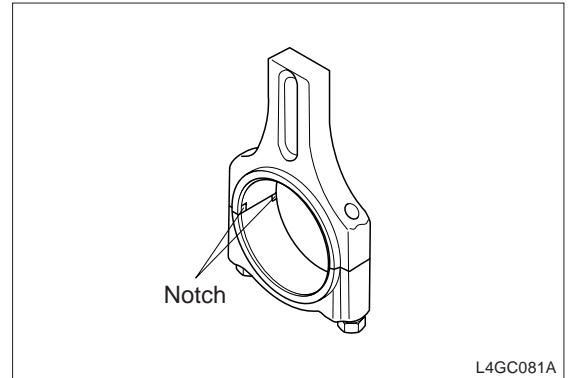

L4GC081A

## ASSEMBLY

1. Using the special tool “piston pin setting tool (09234-33001)”, assemble the piston and connecting rod as below.

- 1) Apply engine oil to the outer surface of the piston pin and small end bore of the connecting rod.

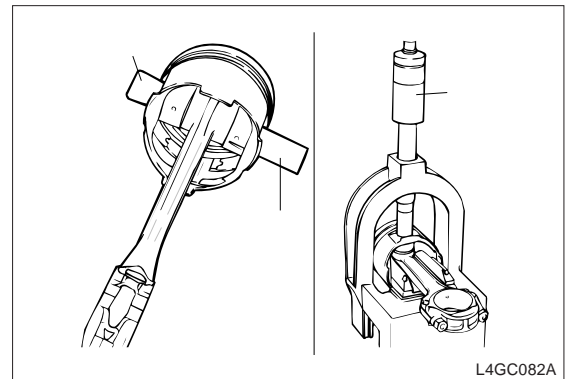

L4GC082A

- 2) With the front mark faced upward, fix the connecting rod and piston and insert it into the piston pin assembly.

### Front mark

Piston side	0 (engraved)
Connecting rod side	Number (embossed)

- 3) Using a press, press-fit the piston pin into the pin hole with the specified pressure on the pin end through the push rod.

If the pressure is required more than the specified value, follow the next step.

Press-fit pressure of piston pin	350 ~ 1350kg
----------------------------------	--------------

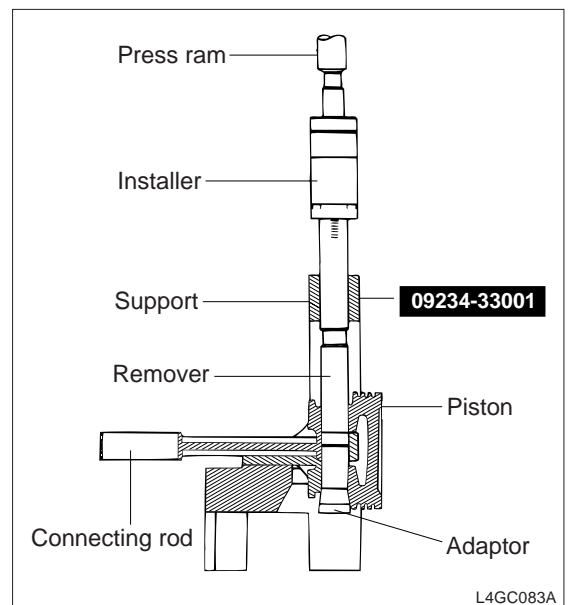

L4GC083A

- 4) Rotate the push rod to a half turn, remove the piston connecting rod assembly from the support.
- 5) After press fitting the piston pin, check that the connecting rod for smooth slip and free movement.

2. Install the piston ring to the piston in the following order.

- 1) Install 3 pieces of oil ring. Install the spacer lower side rail and upper side rail in order.

When installing the side rail, do not use a piston ring expander to expand gap as usual because the side rail is broken. After placing one end of the side rail between the piston ring groove and spacer, grasp the lower side rail securely and press the side rail to the position by hand as shown in the illustration.

At this time, after installing the lower side rail, install the upper side rail.

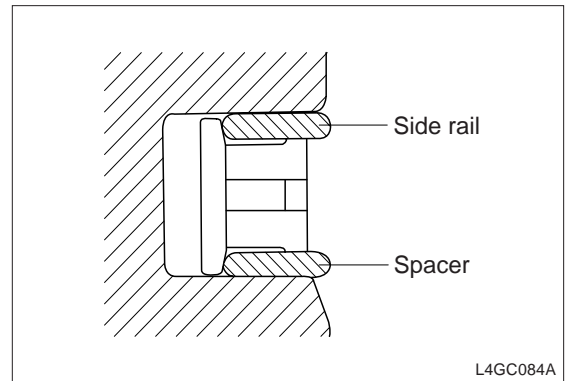

**⚠ CAUTION**

- ***After installing 3 pieces of oil ring, check the upper and lower side rails for smooth rotation.***
- ***The spacer expander gap should be away from the rail gap to 45° or more.***

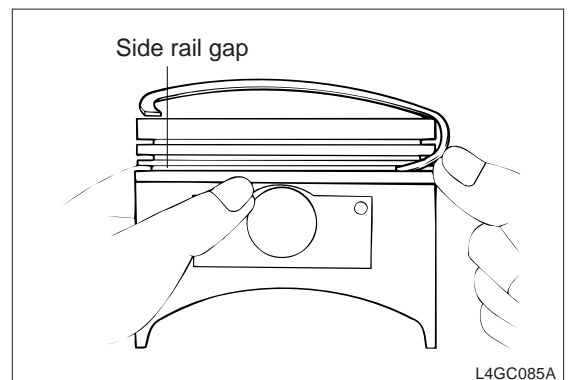

2) After installing no.2 piston ring, install no.1 piston ring.

**CAUTION**

- **Face the size mark and manufacturer mark on the ring surface upward when installing the piston ring.**
- **Take care not to change no.1 and no.2 piston rings.**

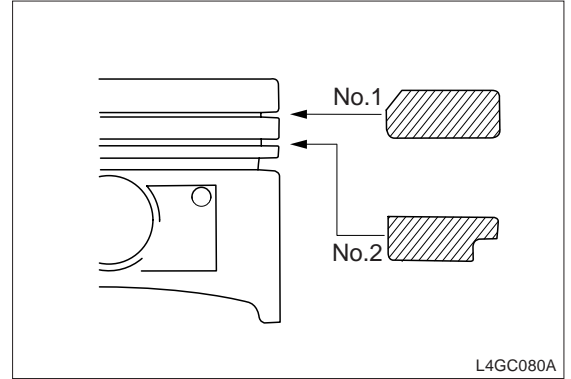

3. Using a piston ring clamp, insert the piston and connecting rod assembly as the cylinder number into the cylinder and face the arrow mark on the piston head toward the engine crankshaft pulley.

Install a vinyl cover to the cap bolt not to damage the cylinder bore and crank pin.

**CAUTION**

- **Be sure that the piston ring gap is same as shown in the illustration. If the piston ring gap is normal, gaps are not aligned with direction of piston and thrust and each gap is away from gaps as far as possible.**
- **Apply enough engine oil to the piston and piston ring round.**

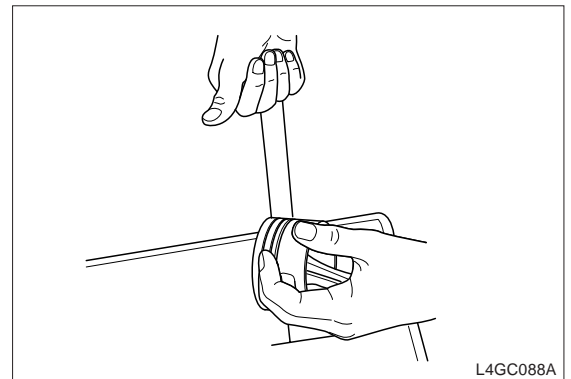
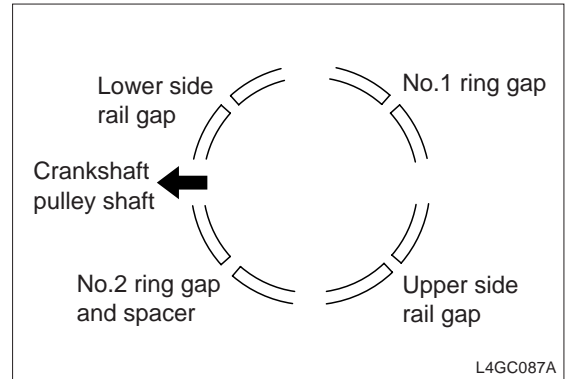

4. Install the connecting rod cap and tighten the cap nut to the specified torque.

When installing the connecting rod cap, align the cylinder number on the connecting rod big end with cylinder number on the cap.

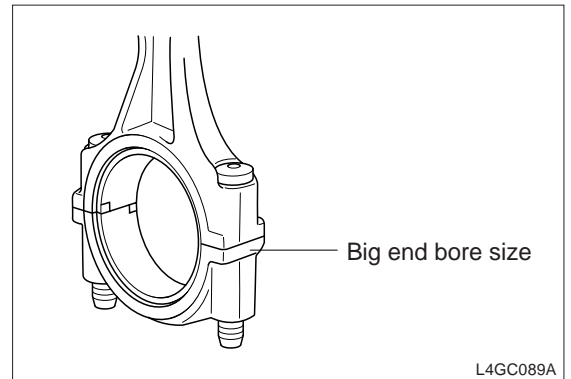

5. Inspect clearance of the connecting rod big end.

Clearance of connecting rod big end	0.1 ~ 0.25mm
-------------------------------------	--------------

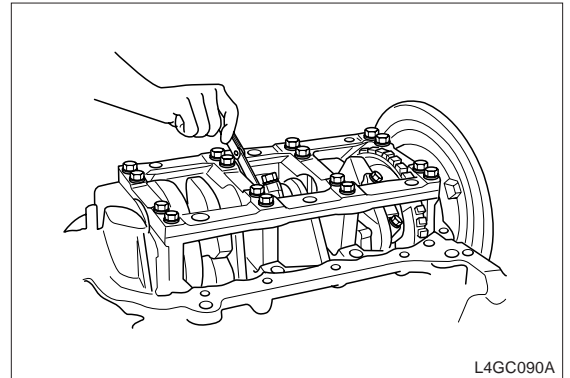

6. Install the oil screen.
7. Install the oil pan.
8. Install the cylinder head.

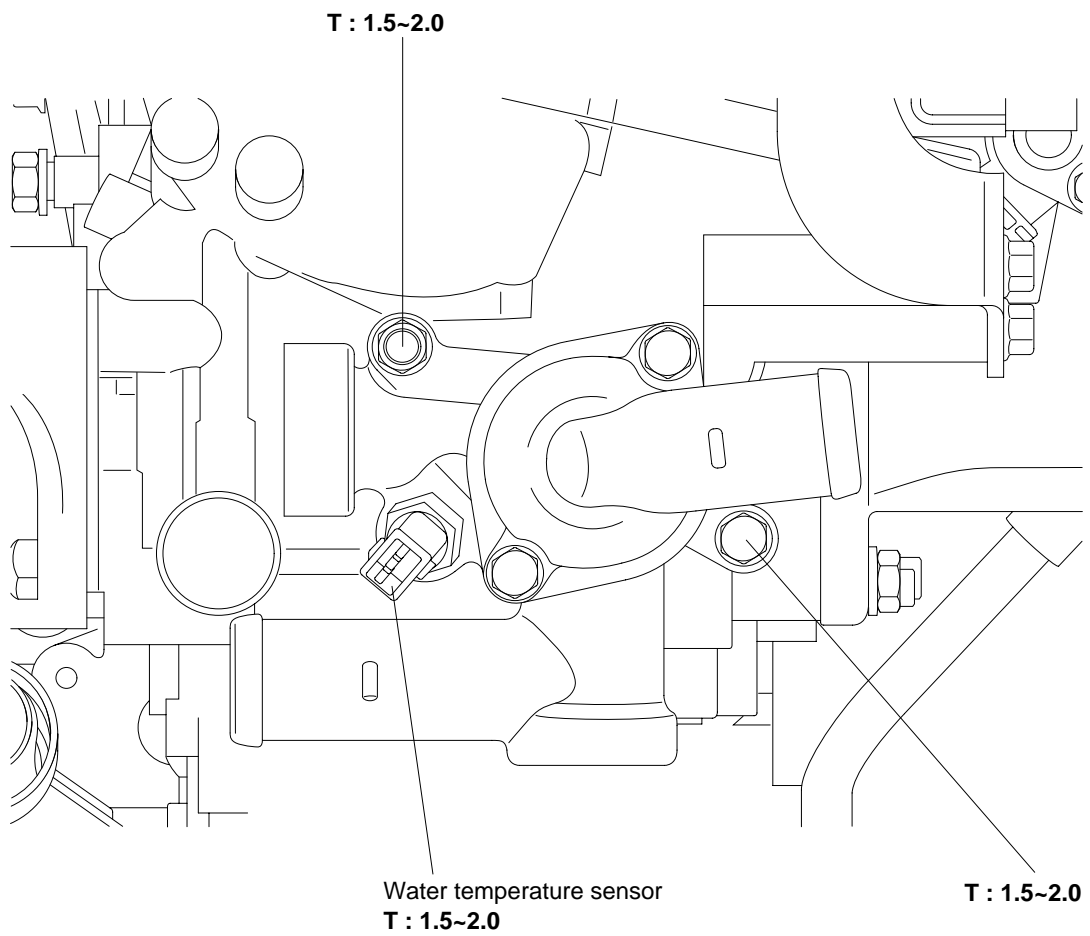

**COOLING SYSTEM****COOLANT PIPE AND HOSE****COMPONENTS**

**Tightening torque : kg·m**

## INSPECTION

Check the coolant pipe and hose for crack, damage, and clogging and replace it if necessary.

## INSTALLATION

After getting water around O-ring, insert it the groove in the coolant intake pipe end and press-fit the pipe.

 **CAUTION**

- *Do not apply oil or grease to the O-ring.*
- *Take care not to dirt the coolant pipe connecting part with sand or dust.*
- *Press-fit the coolant intake pipe completely.*

**WATER PUMP**

**COMPONENTS**

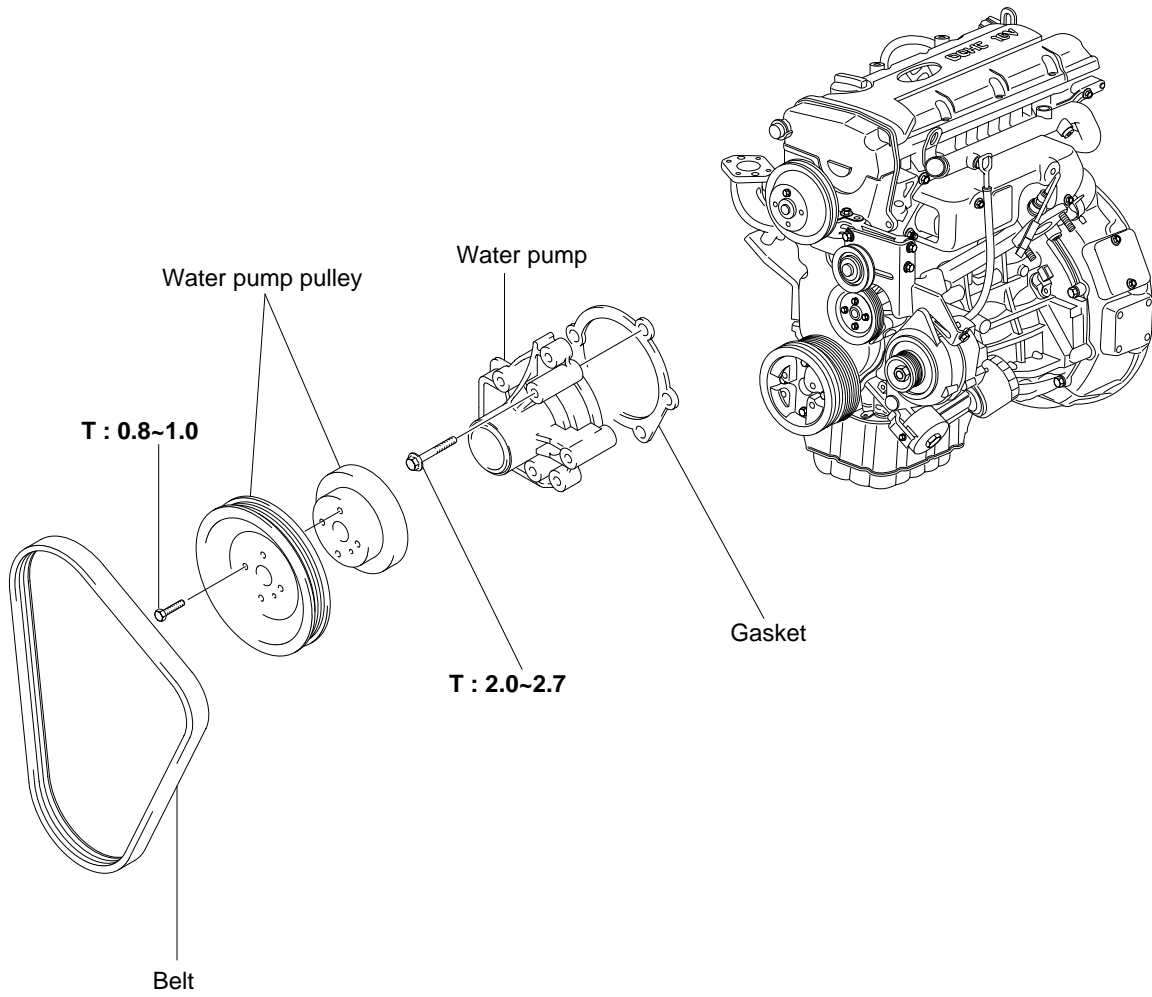

**Tightening torque : kg-m**

**REMOVAL**

1. Check each part for crack, damage, and wear and replace the water pump if necessary.
2. Check the bearing for damage, abnormal noise and bad rotation and replace the water pump if necessary.
3. Check the seal unit for leak and replace the water pump assembly if necessary.

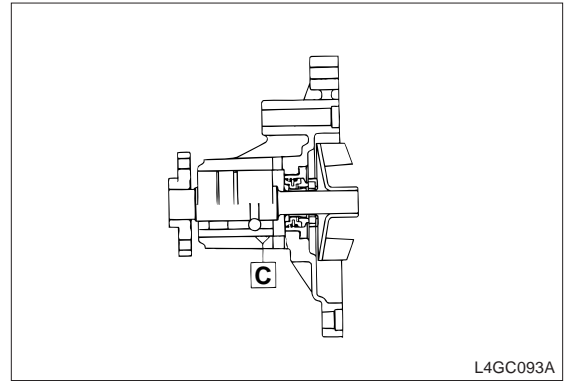

**INSTALLATION**

1. Clean the gasket surface of the water pump body and cylinder block.
2. After getting water around new O-ring, install it the groove in the coolant intake pipe front end. Do not apply oil or grease to the O-ring.
3. Install a new water pump gasket and water pump assembly. Tighten it to the specified torque.

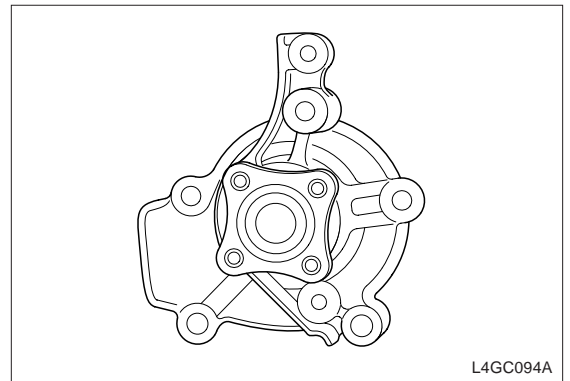

**WATERPUMP AND CYLINDER BLOCK**

A	2.0 ~ 2.7 kg-m
B	2.0 ~ 2.4 kg-m

4. Install the timing belt tensioner and timing belt. Adjust the timing belt tension and install the timing belt cover.
5. After installing the water pump pulley and driving belt, adjust the belt tension.
6. Add the standard coolant.
7. Run the engine and check for leak.

## THERMOSTAT

## COMPONENTS

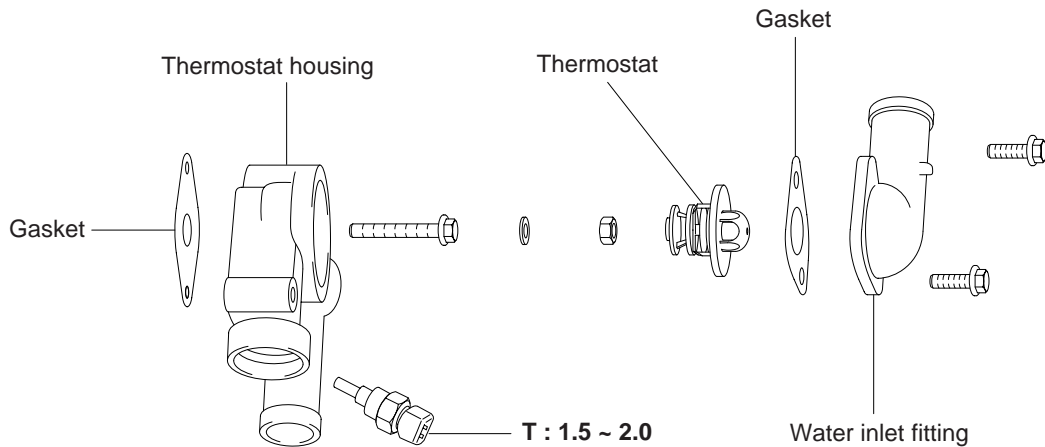

Tightening torque : kg·m

L4GC095A

## INSPECTION

1. Check the valve closed at room temperature.
2. Check for defect or damage.
3. Heat the thermostat as shown in the illustration and measure the valve open temperature and full open temperature.

## Valve open temperature

Open	82°C
Full open	95°C

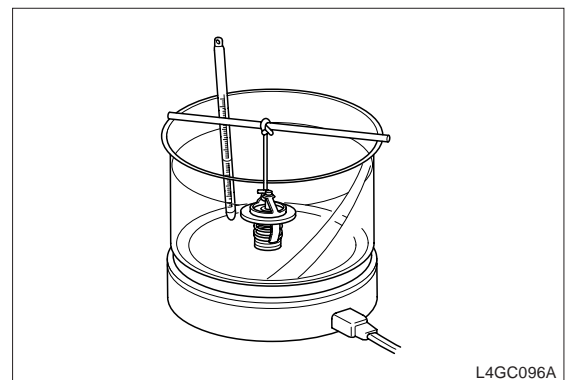

## INSTALLATION

1. Check that the thermostat flange is correctly inserted to the thermostat housing socket.
2. Install a new gasket and water inlet fitting.
3. Add coolant.

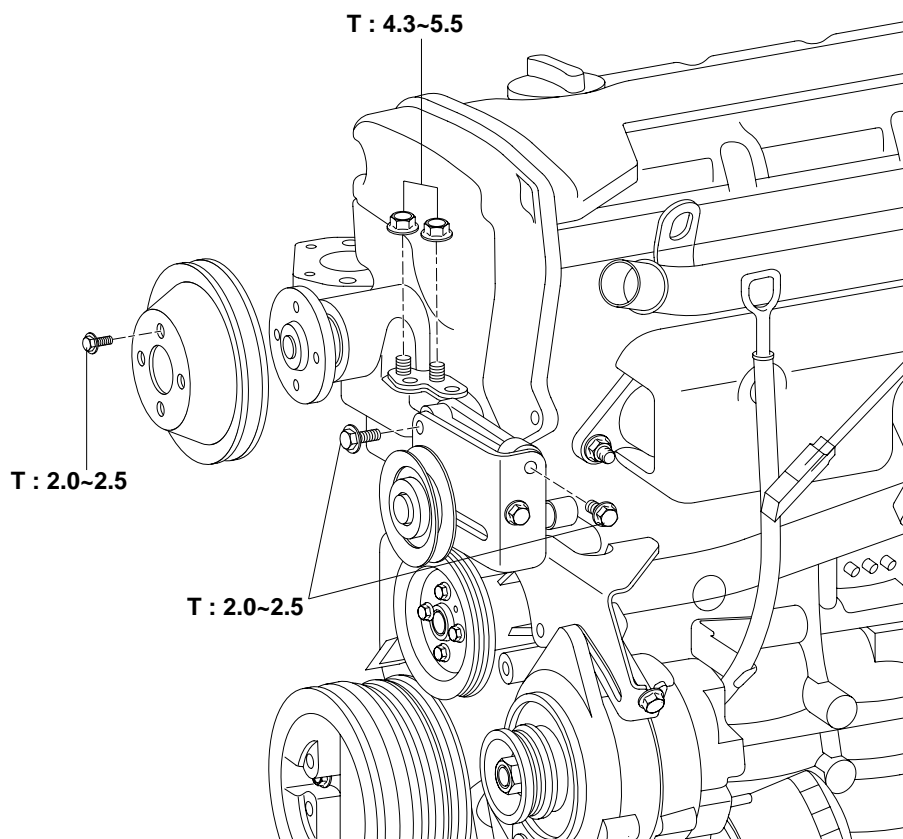
**FAN DRIVE****COMPONENTS**

Tightening torque : kg·m

L4GC097A

**REMOVAL**

1. Remove the fan pulley.
2. Remove the fan bracket.

**INSTALLATION**

Installation is the reverse order of removal.

## LUBRICATION SYSTEM

### OIL PRESSURE SWITCH

Oil pressure switch is located on the front right side of the engine and if oil pressure in the lubrication system drops less than  $0.29\text{kg/cm}^2$ , the oil pressure warning lamp illuminates. Hexagonal width of this switch is 24mm.

### REMOVAL AND INSTALLATION

After applying sealant to the spiral portion, install the oil pressure switch.



#### NOTE

**Do not tighten the oil pressure switch too tight.**

Oil pressure switch	1.3 ~ 1.5kg·m
---------------------	---------------

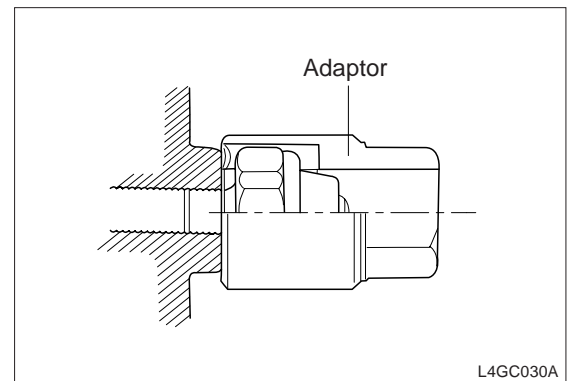

### INSPECTION

- Using an ohmmeter, measure an electric current and replace the oil pressure switch if an electric current is not detected.
- When pressing it with a thin stick, if an electric current is measured between terminal and body, replace the oil pressure switch.
- When applying a negative pressure of  $0.3\text{kg/cm}^2$  through the oil hole, if an electric current is not measured, the switch is normal. If the switch is not normal, check for air leak. If air is leaked, replace the switch because it means damage of the diaphragm.

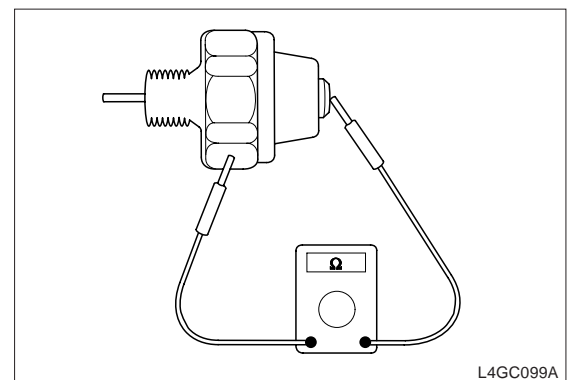
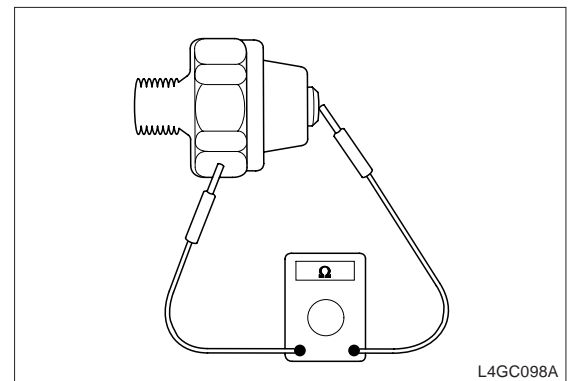

4. Front case (Oil pump)
5. Timing belt
6. Timing belt cover

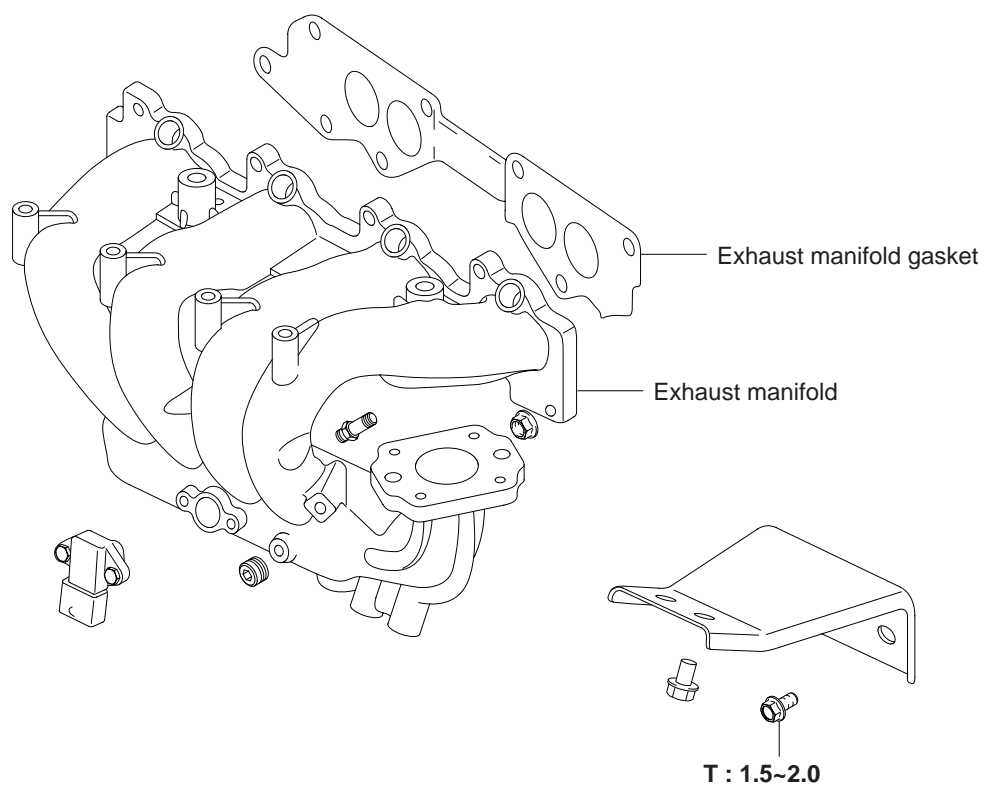

**INTAKE AND EXHAUST SYSTEM****EXHAUST MANIFOLD****COMPONENTS**

Tightening torque : kg·m

## REMOVAL

1. Remove the heat protector.
2. Detach the exhaust manifold from the cylinder head.

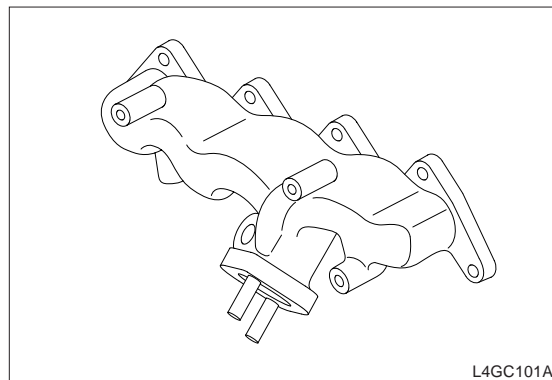

## INSPECTION

1. Check the exhaust manifold for damage and crack.
2. Check the welding part between the exhaust manifold and catalyst for crack and damage.

## INSTALLATION

1. Installation is the reverse order of removal.

**⚠ CAUTION**

***Do not reuse the exhaust manifold gasket nut.***

2. Exhaust manifold gasket  
Check the gasket for tear or damage.

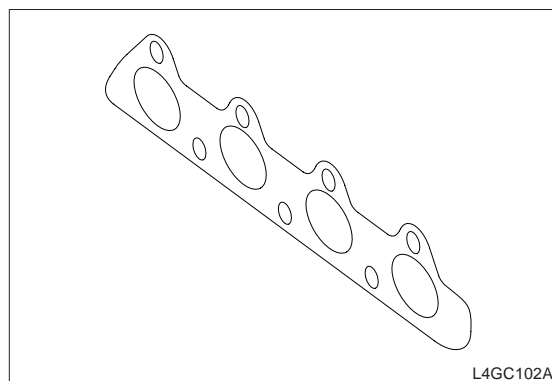

## INTAKE MANIFOLD

## COMPONENTS

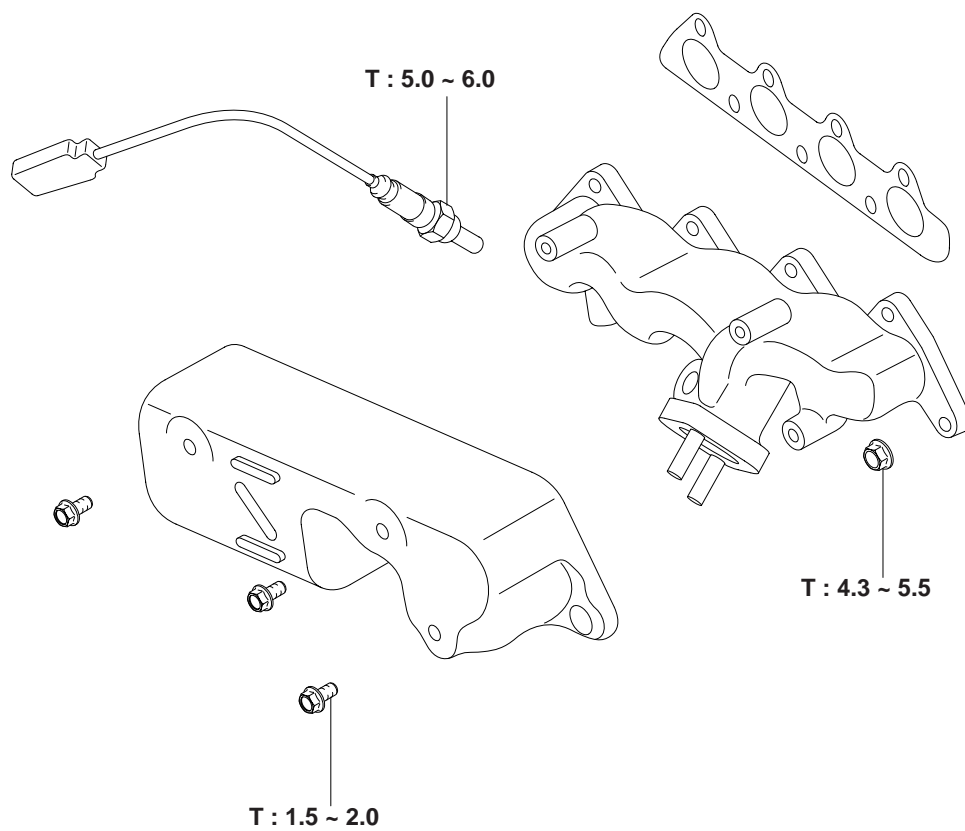

Tightening torque : kg·m

L4GC103A

**CAUTION**

*Do not tighten parts excessively, observe the specified torque.*

## REMOVAL

1. Disconnect the map sensor and the connector.
2. Disconnect the air hose from the throttle body.
3. Remove the accelerator cable.
4. Remove the P.C.V valve hose.
5. Disconnect the vacuum hoses.
6. Disconnect the fuel injector connector and the wiring harness.
7. Remove the delivery pipe with the fuel injector attached.



### CAUTION

*When removing the delivery pipe, take care not to drop the injector.*

8. Remove the intake manifold stay.
9. Remove the intake manifold and gasket.

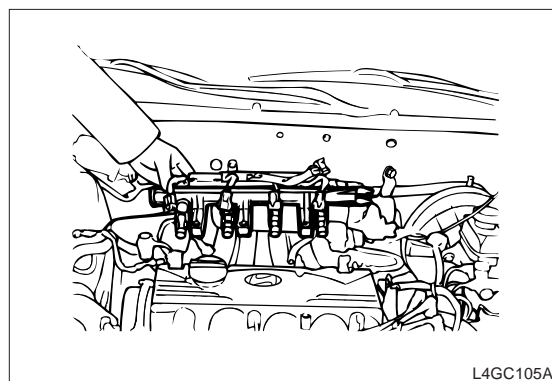

L4GC105A

## INSPECTION

1. Intake manifold  
Check each component for damage and crack.
2. Air hose  
Check each component for damage and crack.

**INSTALLATION**

1. After replacing the intake manifold gasket, install it to the cylinder head and then to the intake manifold.
2. Install the delivery pipe and injector assembly to the intake manifold.

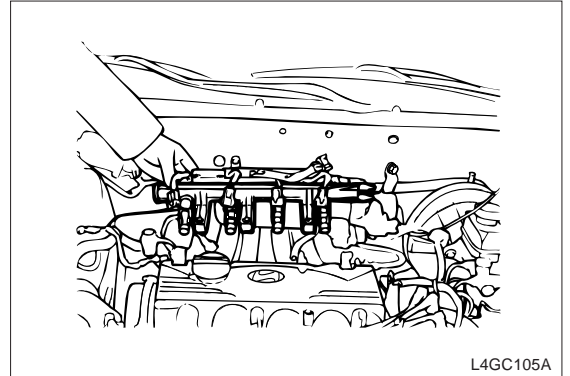
**⚠ CAUTION**

***Check that the injector is interfered with the injector hole in the intake manifold.***

3. Install the fuel injector connector and wiring harness.
4. Connect the high-pressure fuel hose.
5. Connect the vacuum hoses.
6. Connect the P.C.V valve hose.
7. Install the air hose.
8. Check connectors for connection.

**CYLINDER HEAD ASSEMBLY**

**CYLINDER HEAD ASSEMBLY**

**COMPONENTS**

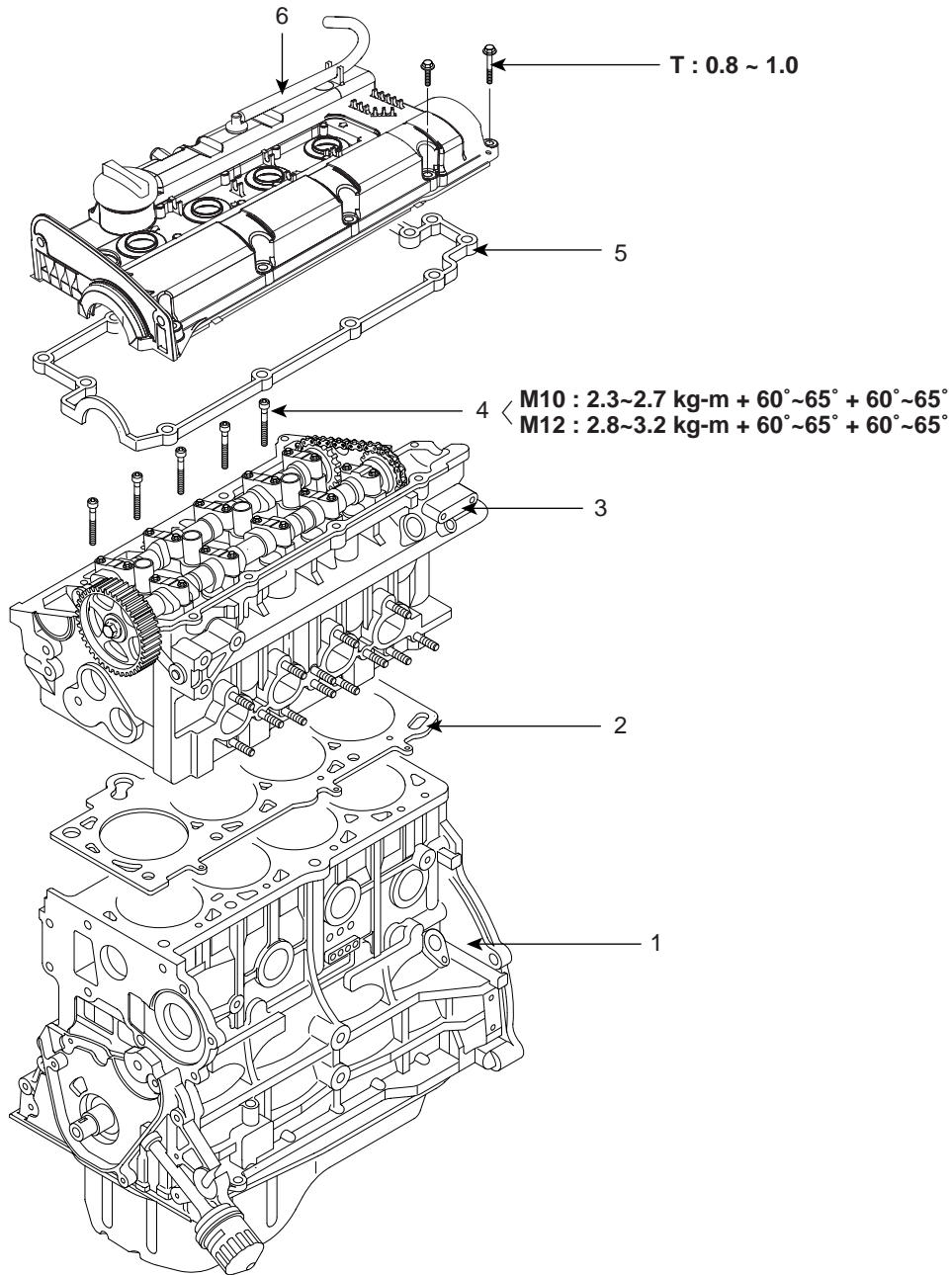

**Tightening torque : kg-m**

L4GC107A

- |                         |                        |
|-------------------------|------------------------|
| 1. Cylinder block       | 4. Cylinder head bolt  |
| 2. Cylinder head gasket | 5. Gasket              |
| 3. Cylinder head        | 6. Cylinder head cover |

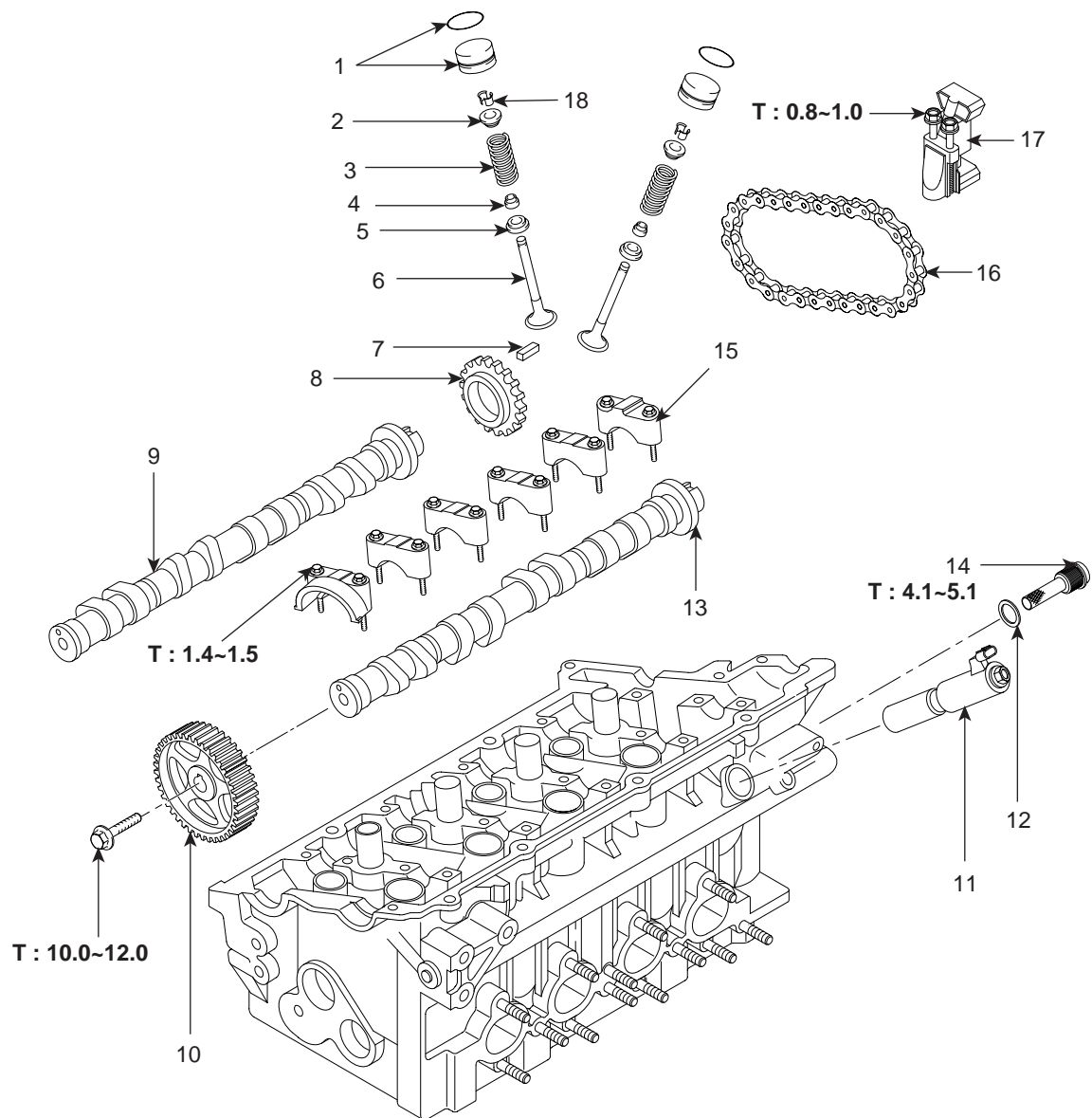

Tightening torque : kg·m

L4GC108A

- |   |                            |                                   |
|---|----------------------------|-----------------------------------|
| 1. MLS(Mechanical valve clearance adjusting system) | 7. Key                     | 14. OCV(Oil control valve) filter |
| 2. Retainer   | 8. Chain sprocket          | 15. Camshaft bearing cap          |
| 3. Valve spring                                     | 9. Intake camshaft         | 16. Timing chain                  |
| 4. Stem seal  | 10. Camshaft sprocket      | 17. Auto tensioner                |
| 5. Spring seat                                      | 11. OCV(Oil control valve) | 18. Retainer lock                 |
| 6. Valve  | 12. Washer                 |                                   |
|   | 13. Exhaust camshaft       |                                   |

**DISASSEMBLY**

- Using the special tool “cylinder head bolt wrench (09221-32001)”, tighten the cylinder head bolts in order by tightening 2-3 times as shown in the illustration.

- Take care not to come the cylinder head gasket debris into the cylinder.**

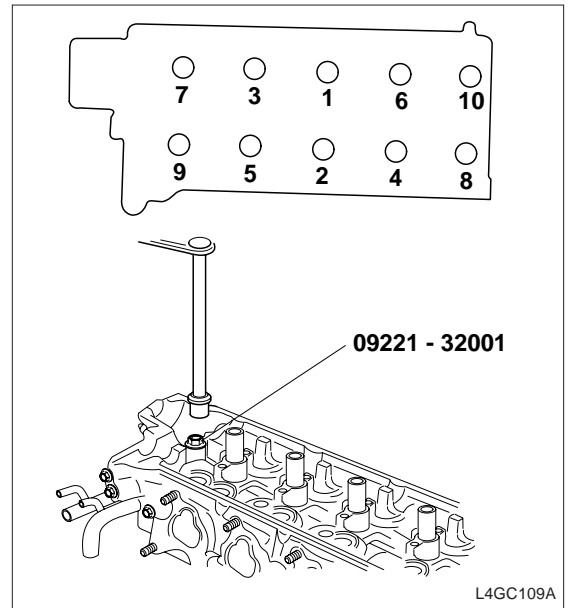

- Using the special tool “valve spring compressor (09221-29100)”, remove the retainer lock. And then, remove the spring retainer, valve spring, spring seat and valve.

**NOTE**

**Arrange parts in order disassembling not to make a mistake while reassembling.**

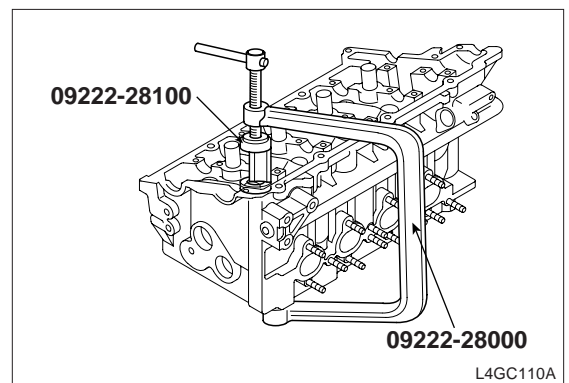

- Remove the stem seal with pliers.

**NOTE**

**Do not reuse the stem seal.**

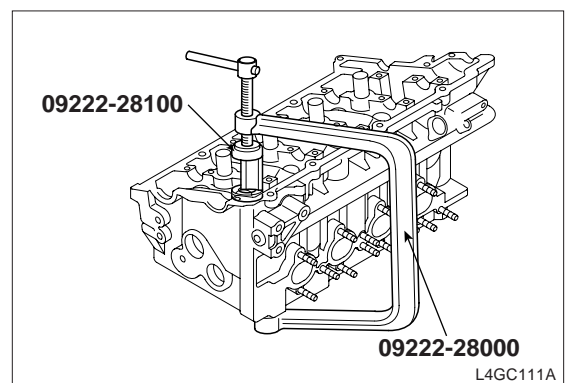



## INSPECTION

### CYLINDER HEAD

1. Check the cylinder head for crack, damage and leak.
2. Clean out fur, adhesive and accumulated carbon and after cleaning the oil passage, bleed the passage with compressed air to check it for clogging.
3. Using a square, check the cylinder head gasket for flatness from A and B directions shown in the illustration. If any flatness is out of the limit, replace the cylinder head or slightly cut the cylinder head gasket surface.

Flatness of cylinder head gasket surface	Standard	0.03mm or less
	Limit	0.06mm

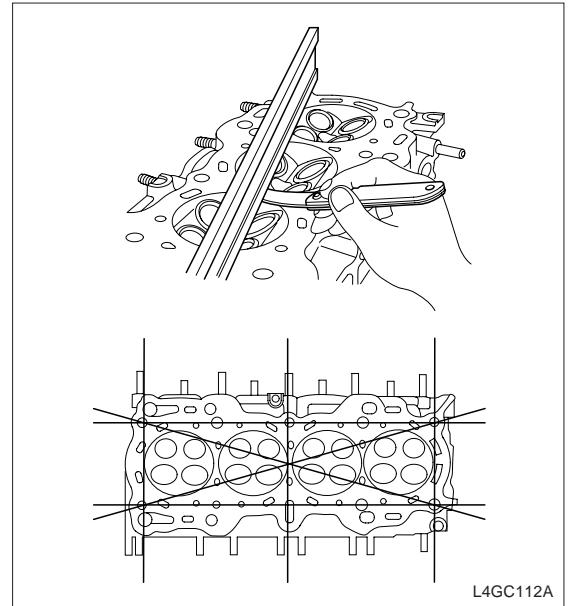

### VALVE

1. Clean the valve with a wire brush.
2. Check each valve for wear and damage and inspect the head and stem for torsion.  
If the stem end A is cave or worn, trim it.  
At this time, trim it least.  
Also, trim the valve surface.  
If the margin is less than the limit, replace the valve.

#### Valve margin

Standard	Intake	1.15mm
	Exhaust	1.35mm
Limit	Intake	0.8mm
	Exhaust	1.0mm

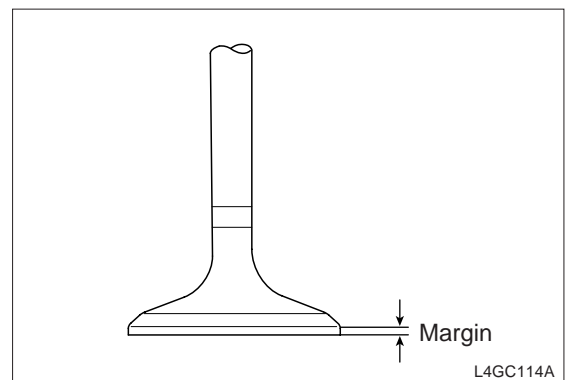
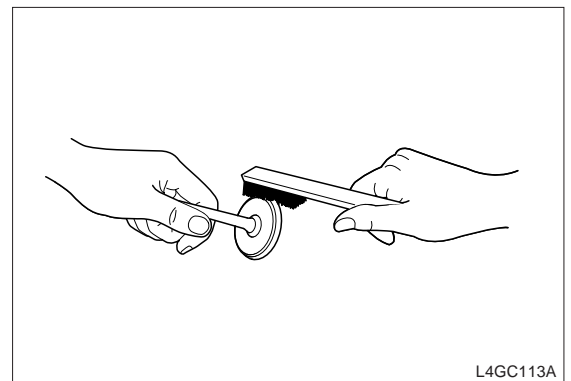

**VALVE SPRING**

1. Measure free height of the valve spring and replace the spring if the measured value exceeds the limit.
2. Using a square, measure squareness of each spring and replace it if the measured value is out of squareness excessively.

**Valve spring**

Standard	Free height	48.86mm
	Installed load	18.3kg / 39mm
	Compressed load	40.0kg / 30.5mm
	Out-of-squareness	1.5° or less
Limit	Free height	-1.0mm
	Out-of-squareness	3 °

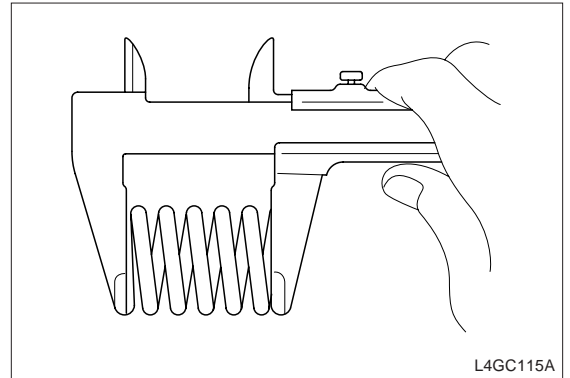

3. Measure the clearance between the valve stem and guide and if the measured value exceeds the limit, replace the valve guide with the following over size parts.

**Valve stem and guide clearance**

Standard	Intake	0.02 ~ 0.05mm
	Exhaust	0.035 ~ 0.065mm
Limit	Intake	0.1mm
	Exhaust	0.13mm

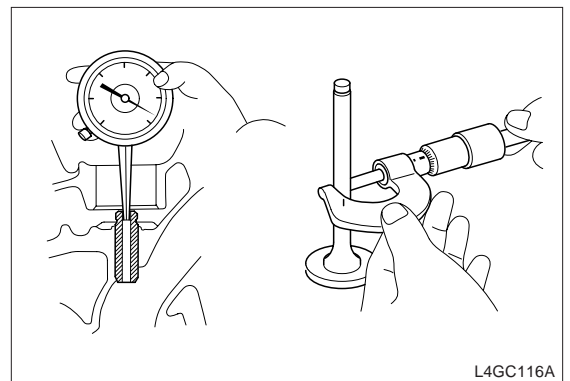

**VALVE SEAT CORRECTION**

Check the valve seat for overheat and inspect contact with valve surface. Correct or replace it if necessary. When correcting, check the valve guide for wear, if it is worn, replace the guide and correct the seat ring. Using a grinder or a cutter, correct the valve seat to make the seat contact width to the standard. When correcting the exhaust valve seat, must use the valve seat voice and pilot, after correcting, must apply a light coat of compound to the valve and valve seat.

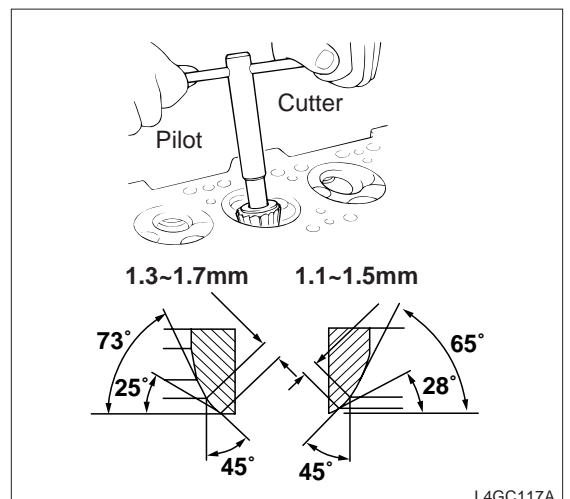

## VALVE SEAT RING REPLACEMENT

1. If the valve seat insert is excessively worn, cut the insert ring wall as shown in the illustration "A" using a valve seat cutter at a normal temperature.

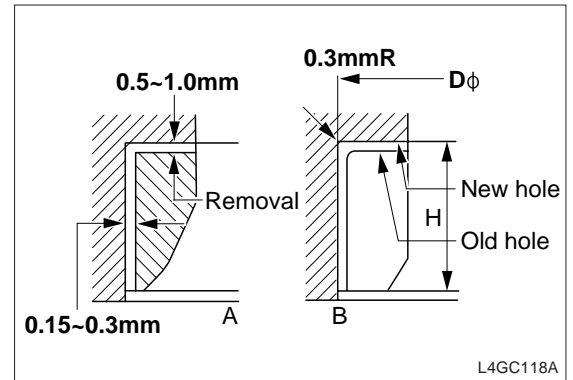

2. After removing the seat ring, Cut the seat insert bore as same size as the following table using a reamer or cutter.
3. Heat the cylinder head to 250°C and press-fit the oversize seat.  
At this time the oversize seat ring maintains a normal room temperature.  
After installing a new valve seat, correct the valve seat surface.

## Valve seat ring oversize

Item	Size (mm)	Size mark	Cylinder insert height H (mm)	Cylinder head I.D (mm)
Intake valve seat ring	0.3 OS	30	7.5 ~ 7.7	33.330 ~ 33.325
	0.6 OS	60	7.8 ~ 8.0	33.600 ~ 33.625
Exhaust valve seat ring	0.3 OS	30	7.9 ~ 8.1	28.800 ~ 28.821
	0.6 OS	60	8.2 ~ 8.4	29.100 ~ 29.121

**VALVE GUIDE REPLACEMENT**

Because the valve guide is press-fitted, replace the valve guide as the following procedures using a valve guide installer or proper tool.

1. Remove the valve guide pressed toward cylinder block using a push rod of valve guide installer.
2. Cut the valve guide insert bore of the cylinder head to the valve guide oversize.
3. Press-fit the valve guide using a valve guide installer or proper tool. When using a valve guide installer, Use a valve guide installer to press-fit the valve guide to the specified height.

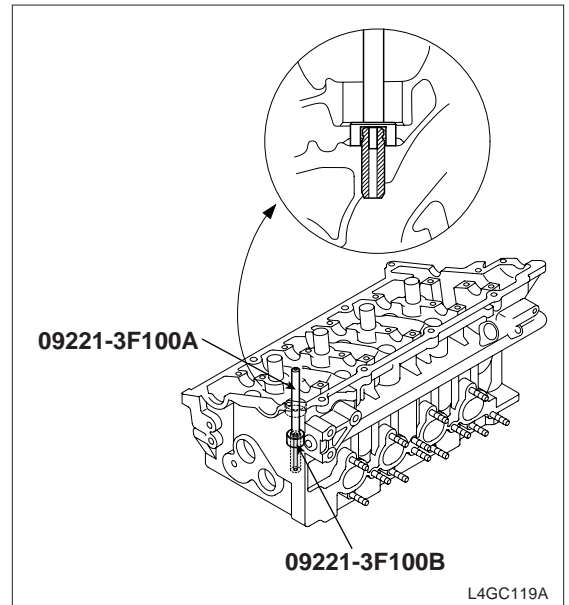

4. When installing, start from top of valve guide cylinder head. Be sure that the intake valve guide is not same size with the exhaust valve guide. (Intake valve guide : 46.0mm, exhaust valve guide : 54.5mm)
5. After installing the valve guide, insert a new valve and check for perturbation.
6. When replacing the valve guide, check the valve for contact and correct the valve seat if necessary.

**Valve guide oversize**

Size	Size mark	Cylinder head bore size
0.05 OS	5	11.05 ~ 11.068mm
0.25 OS	25	11.25 ~ 11.268mm
0.50 OS	50	11.50 ~ 11.518mm

## ASSEMBLY

**⚠ CAUTION**

- *Prior to assembly, clean each component.*
- *Apply a new engine oil to the perturbation part and rotation part.*

1. After installing the spring seat, insert the stem seal to the valve guide.

Install the stem seal by tapping on it with the special tool “valve stem oil seal installer (09222-22001)”.

Wrong installation of the seal can affect oil leak from the valve guide, so use the special tool to install it to exact position and take care not to twist it. Do not reuse it.

2. After applying engine oil to each valve, insert the valve into the valve guide.

3. Install the spring and spring retainer. Face the enamel-plated side toward the valve spring retainer side.

4. Taking care not to press the valve stem seal down to the retainer bottom, press-fit the spring with the special tool “valve spring compressor (09222-28000, 09222-28100)”.

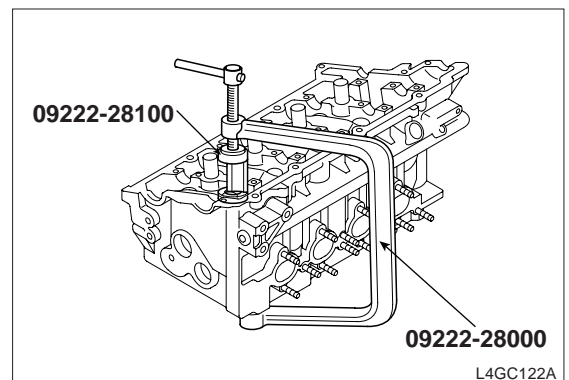
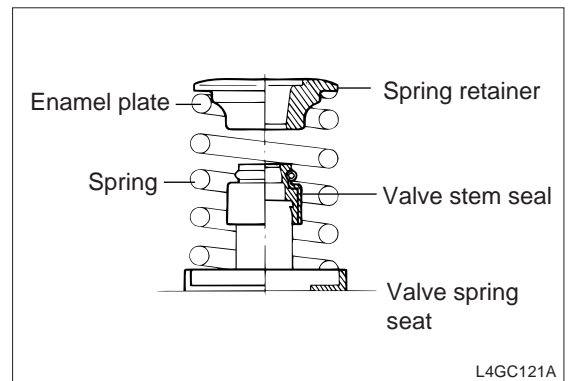
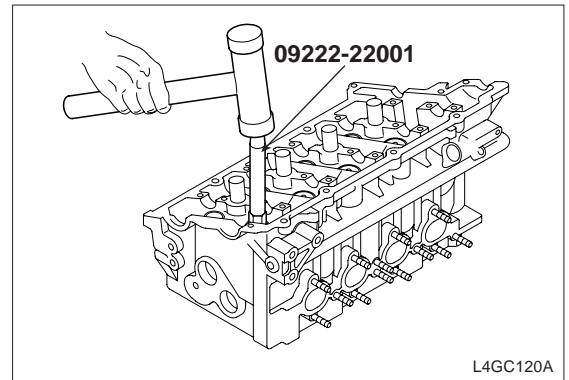

5. Clean out all gasket surfaces of the cylinder block and cylinder head.
6. Put new cylinder head gaskets on the cylinder block with the identification marks faced upward. Do not apply sealant to the gasket and do not reuse the used cylinder head gasket. Take care not to make a mistake of gasket.
7. Put the cylinder head on the cylinder block.
8. Apply a slight coat of engine oil to the spiral portion of bolt.
9. Insert the washer to the bolt and insert it to the cylinder head.
10. Using the special tool "cylinder head bolt wrench (09221-32001)", install the cylinder head bolt as shown in the illustration.

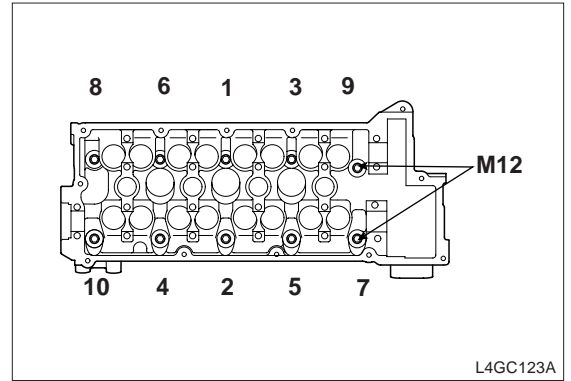

**Cylinder head bolt**

M10	2.5kg·m + (60° ~ 65°) + (60° ~ 65°)
M12	3.0kg·m + (60° ~ 65°) + (60° ~ 65°)

## TIMING BELT

## COMPONENTS

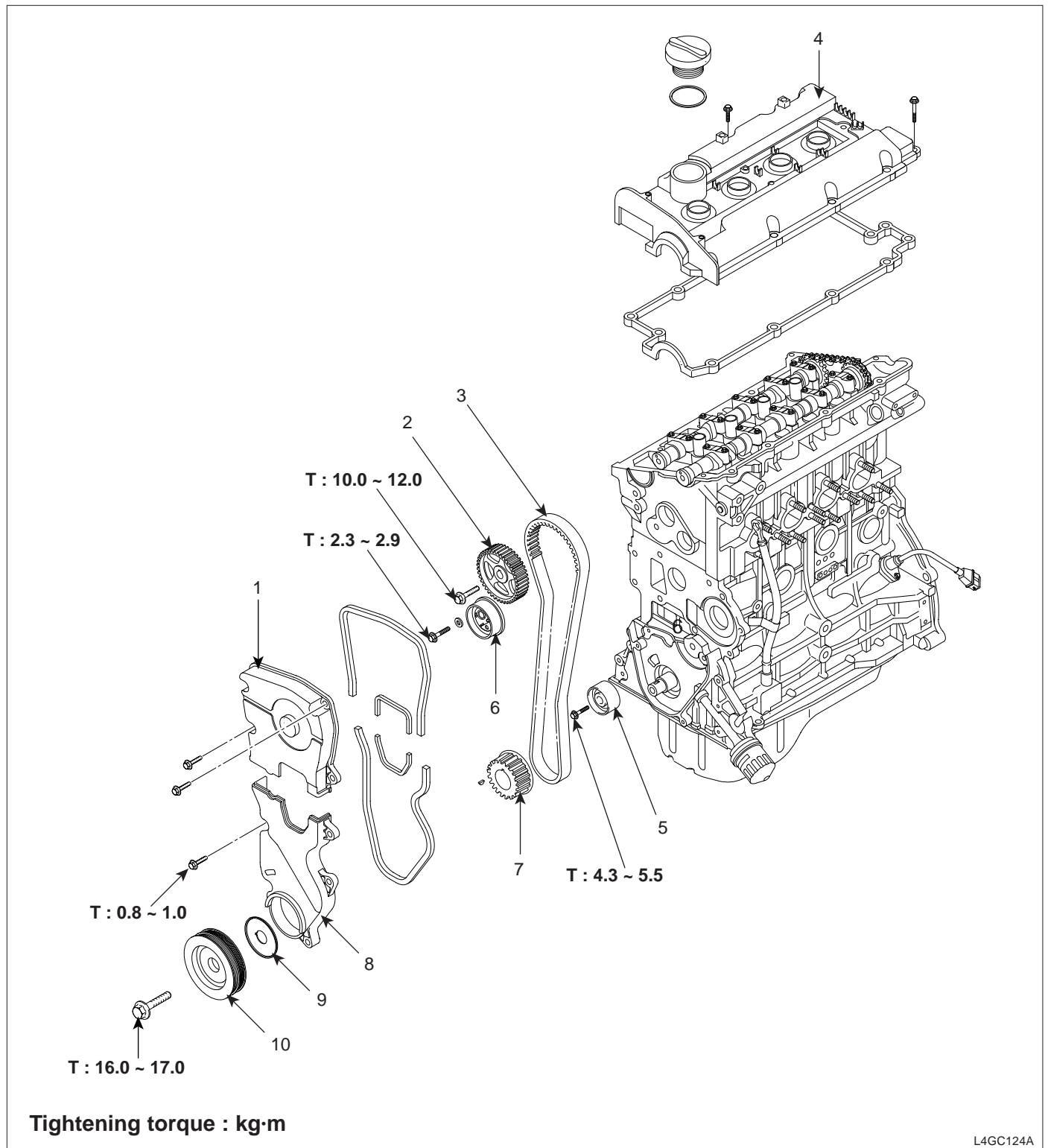

L4GC124A

- |                             |                        |                            |
|-----------------------------|------------------------|----------------------------|
| 1. Timing belt upper cover. | 4. Cylinder head cover | 7. Crankshaft sprocket     |
| 2. Camshaft sprocket        | 5. Idler               | 8. Timing belt lower cover |
| 3. Cylinder head cover      | 6. Tensioner           | 9. Flange                  |
|                             |                        | 10. Crankshaft pulley      |

**REMOVAL**

1. Loosen the water pump pulley belt.
2. Loosen the alternator bolt.
3. Remove the water pump pulley and belt.

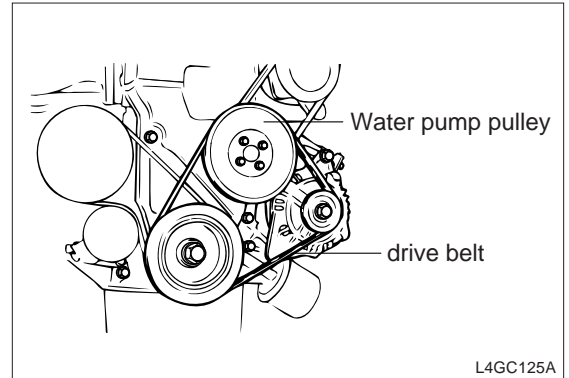

4. Crankshaft pulley.
5. Remove the timing belt cover.

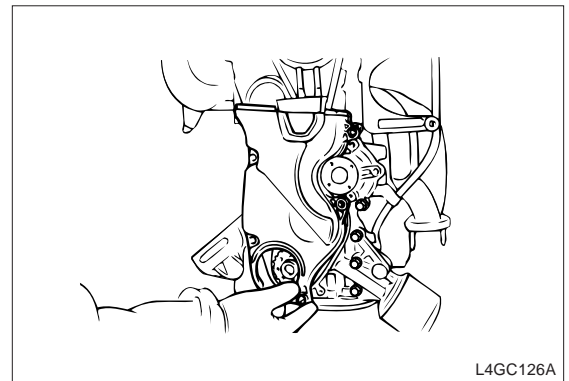

6. Remove the timing belt tensioner pulley.

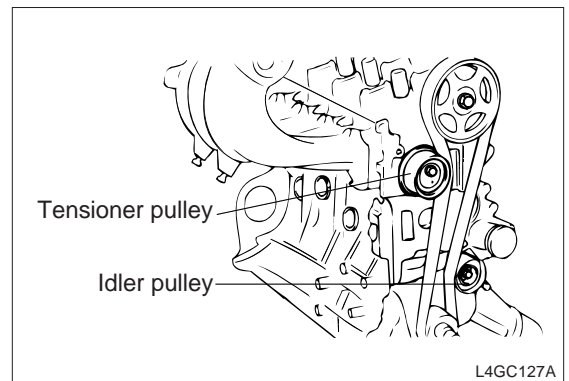

7. Remove the timing belt from the camshaft sprocket.
8. Remove the camshaft sprocket.
9. Remove the timing belt.

**NOTE**

*When reusing the timing belt, put an arrow mark on the rotation direction (or front side of engine) before removal to help re-install it to original installation direction.*

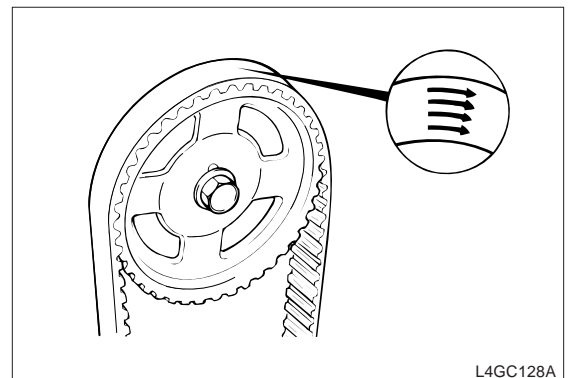



10. Remove the idler.
11. Loosen the camshaft sprocket bolt and remove the camshaft sprocket.

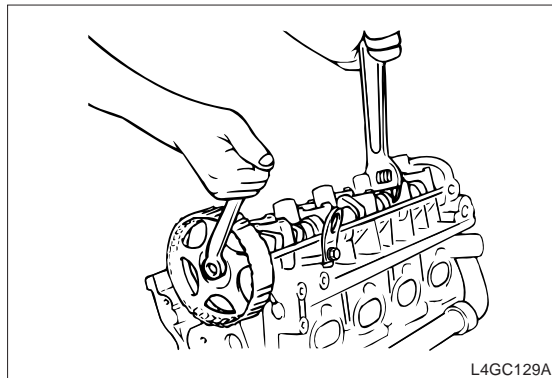

12. Remove the crankshaft sprocket bolt and remove the crankshaft sprocket and flange.
13. Remove the timing belt tensioner.

**INSPECTION****SPROCKET, TENSIONER, IDLER**

1. Check the camshaft sprocket, crankshaft sprocket, tensioner and idler for wear, crack and damage and replace it if necessary.
2. Check the tensioner and idler pulley for smooth rotation, check for play and noise, and replace it if necessary.

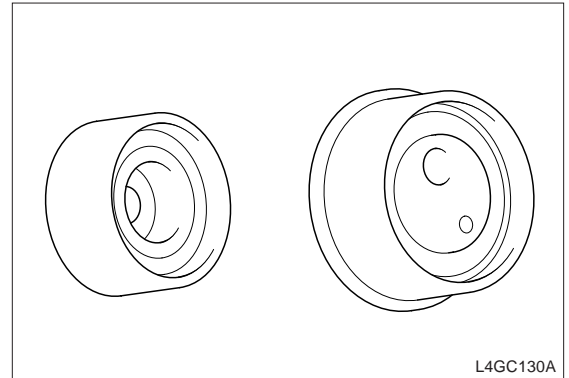

3. If grease leak is inspected, replace it.

**TIMING BELT**

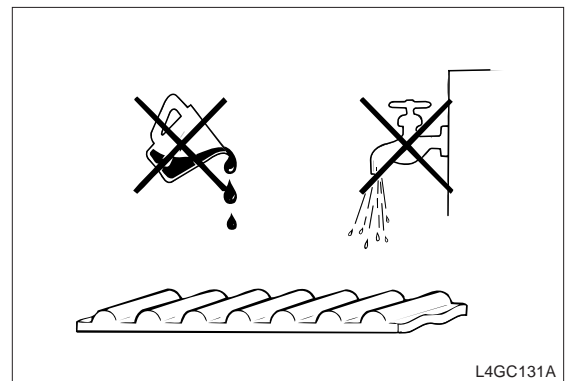

1. Check the belt for oil or dust deposit and replace it if necessary. In case of small amount of oil or dust, clean it with a rag or paper instead of a solvent.



2. After overhauling the engine or readjusting the belt, inspect the belt in detail and replace it with a new one if the following defects are detected.

**⚠ CAUTION**

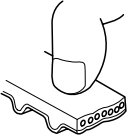
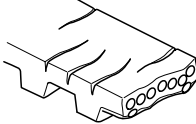
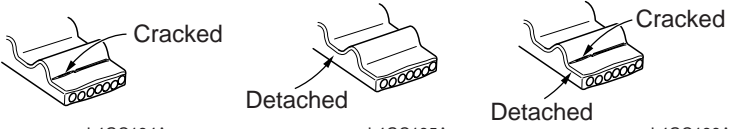
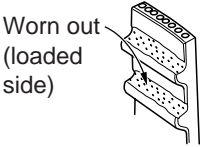
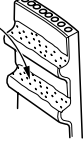
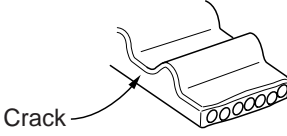
- **Do not bend or twist the timing belt.**
- **Take care not to contact the timing belt with oil, water, grease and steam.**

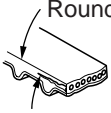
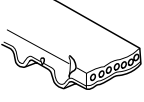
Description	Specification	
1. Back side rubber is hardened	Glossy back side. Due to non-elasticity and hardening, when pressing it with the tip of a finger, there is no sign of it. 	
2. Back side rubber is cracked		
3. Canvas is cracked or detached		
4. Tooth is excessively worn out (initial step)	Tooth loaded from canvas is worn (elastic canvas fiber rubber is worn, color is faded in white, canvas structure is deformed) 	
5. Tooth is excessively worn out (final step)	Tooth loaded from canvas is worn and rubber is worn off (tooth width is narrowed) 	
6. Tooth bottom is cracked		
7. Tooth is missing	Tooth is missing and canvas fiber is worn off 	
8. The side of belt is severely worn out	Rounding belt side Abnormal wear (Canvas fiber is cracked) 	
9. The side of belt is cracked	<b>NOTE</b> <i>In case of normal belt, it is cut precisely as if cut with a sharp cutter</i> 	

## ASSEMBLY

1. Install the flange and crankshaft sprocket taking care of installation direction as shown in the illustration.

Crankshaft sprocket bolt	17 ~ 18kg·m
--------------------------	-------------

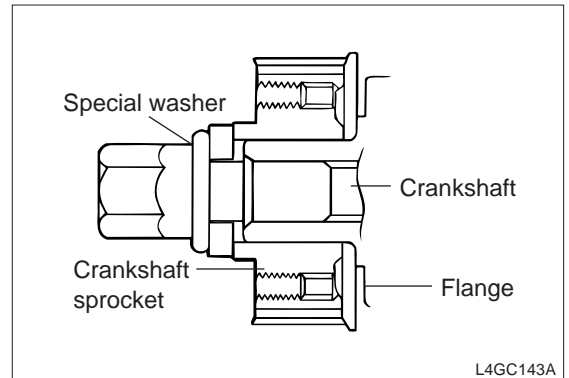

2. Install the camshaft sprocket and tighten the bolt to the specified torque.

Crankshaft sprocket bolt	10 ~ 12kg·m
--------------------------	-------------

3. Install the idler and tighten the bolt to the specified torque.

Idler fixing bolt	4.3 ~ 5.5kg·m
-------------------	---------------

4. With no.1 cylinder piston to the dead point of compression stroke, align the timing mark on the camshaft sprocket and timing mark on the crankshaft sprocket.

- 1) After installing the tensioner, spring and spacer and tightening the bolt temporarily, tighten the long hole shaft washer of tensioner and bolt.
- 2) Install the spring bottom end to the front case as shown in the illustration.
- 3) Install the flange and crankshaft sprocket taking care of installation direction and then tighten the washer and bolt temporarily.
- 4) When aligning the timing marks, after turning the camshaft sprocket to place the red timing mark on the cam cap in the middle of the knock pin  $\varnothing 4.5$  bore, align this timing mark with the timing mark on the front case by rotating the shaft sprocket.
- 5) Install the belt with the timing aligned as shown in the illustration. (When installing, start from the belt tension side and then install the belt by pressing the tensioner.

**CAUTION**

**When no.1 piston is at TDC, if the camshaft sprocket mark is not aligned more than 2 teeth, interference between piston and valve occurs. So take care of timing aligning.**

- 6) Install the timing belt not to loosen in the following order.  
Crankshaft sprocket(A) → Idler pulley(B) → Camshaft sprocket(C) → Timing belt tensioner(D).  
(After installing timing belt, auto tensioner may be installed)

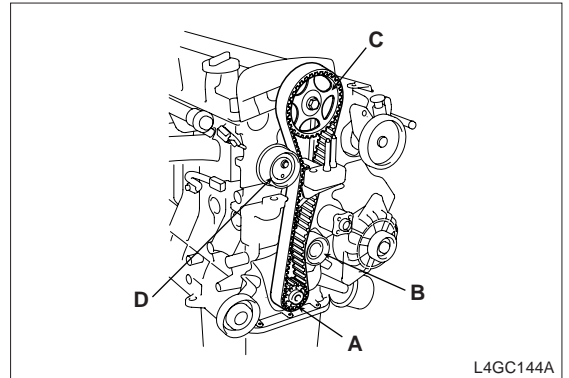

- 7) Be sure that timing mark on each sprocket is placed on the proper position.  
8) Remove the tensioner arm fixing pin.  
9) Insert a hexagonal wrench to the adjuster groove as below, rotate it counterclockwise to place the arm indicator in the middle of base groove.

**⚠ CAUTION**

***Do not rotate the wrench clockwise, or the auto tensioner is not normally functioned.***

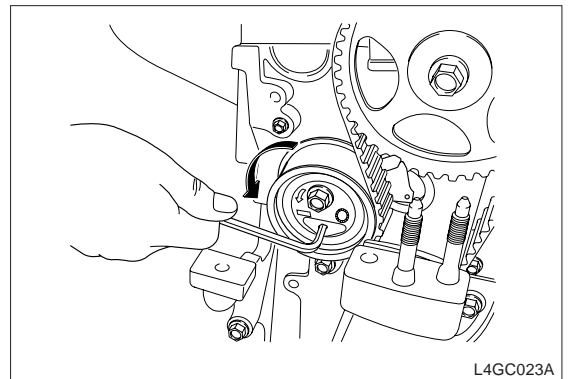

- 10) With the arm indicator fixed not to move, tighten the tensioner fixing bolt.

Tightening torque	2.3 ~ 2.9kgf·m
-------------------	----------------

- 11) Rotate the crankshaft to 2 turns clockwise and then be sure that the auto tensioner arm indicator is placed in the middle of base groove.  
12) If the arm indicator is out of the middle of groove, loosen the bolt and repeat the above procedure.  
13) Install the timing belt lower cover.

Tightening torque	0.8 ~ 1.0kgf·m
-------------------	----------------

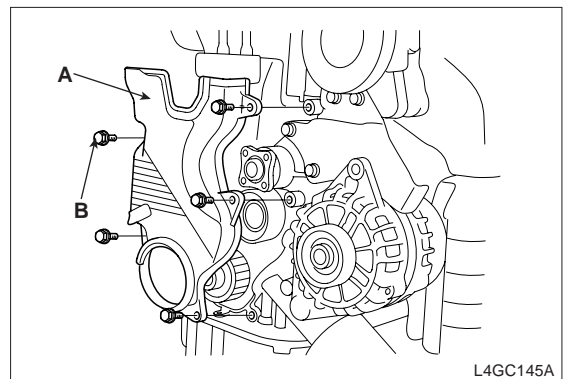

14) Install the crankshaft pulley(A) together with the flange, tighten the bolt(B).

When installing, align the crankshaft key with the pulley groove.

**Crankshaft pulley bolt**

Tightening torque	16.0 ~ 17.0kgf·m
-------------------	------------------

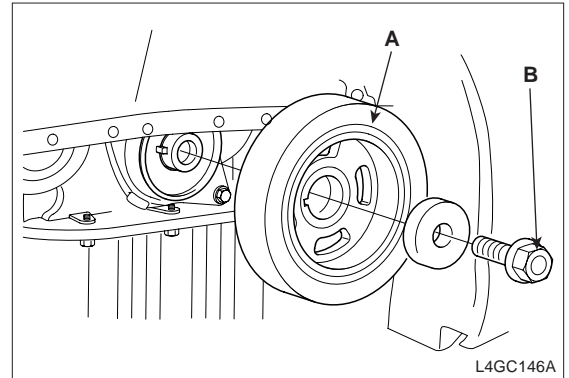

15) Install the timing belt upper cover.

Tightening torque	0.8 ~ 1.0kgf·m
-------------------	----------------

16) Install the water pump pulley.

17) Install the alternator driving belt.

18) Tighten the water pump pulley fixing bolt.

## **CHAPTER 3. ENGINE ELECTRICAL SYSTEM**

<b>1. GENERAL .....</b>	<b>3- 1</b>
<b>2. IGNITION SYSTEM .....</b>	<b>3- 3</b>
<b>3. CHARGING SYSTEM .....</b>	<b>3- 9</b>
<b>4. STARTING SYSTEM .....</b>	<b>3- 25</b>



## GENERAL

### SPECIFICATIONS

#### #1 TDC SENSOR

Item	Specification
Type	Non-contacting type
Advance system	Controlled by ECU
Ignition order	1→3→4→2

#### CRANKSHAFT POSITION SENSOR

Item	Specification
Type	Non-contacting type
Advance system	Controlled by ECU
Ignition order	1→3→4→2

#### IGNITION COIL

Item	Specification
1 <sup>st</sup> coil resistance	$0.58 \pm 10\%(\Omega)$
2 <sup>nd</sup> coil resistance	$8.8 \pm 15\%(\Omega)$

#### SPARK PLUG

Item	Specification	
Type	NGK	PFR6N
	CHAMPION	RC8PYPB
Spark plug gap	0.7 ~ 0.8mm	

#### STARTER MOTOR

Item	Specification	
Output	1.7 kW	
Pinion tooth number	8	
No-load characteristic	Terminal voltage	11V
	Maximum current	90A
	Minimum speed	2600 rpm



## ALTERNATOR

Item	Specification
Type	Battery voltage sensing type
Rated output	13.5V 90A
RPM	1,000 ~ 18,000rpm
Regulator adjusting voltage	$14.4 \pm 0.3V/20^{\circ}C$
Temperature compensation	$-10 \pm 3mV/^{\circ}C$
Voltage regulator type	Electro-magnetic, Built-in type

 **NOTE**

1. **Cold cranking ampere** : It means that terminal voltage is maintained 7.2V or more at a certain temperature and battery current is supplied for 30 seconds.
2. **Reserve capacity** : It represents the time can be supplied 25A from battery with minimum terminal voltage maintained 10.5V at 26.7°C.

## IGNITION SYSTEM

### GENERAL

1. If the ignition switch is ON, the battery voltage is supplied to 1<sup>st</sup> coil of ignition coil.
2. By rotation of the crank position sensor wheel, ignition signal in ECU is actuated the power transistor and repeat ground or shut off of 1<sup>st</sup> current of ignition coil.
3. This causes high pressure in 2<sup>nd</sup> coil, the induced current from ignition coil to 2<sup>nd</sup>, coil is grounded though the spark plug and each cylinder is ignited.

### TROUBLESHOOTING

When it is hard to start engine, there can be problem with fuel system or engine itself as well as ignition system.

Because main function of ignition system is to supply sufficient electronic spark at a proper timing, when inspecting this system, necessarily contains spark checking and ignition timing measurement. When inspecting ignition system installed to the vehicle, check for possible trouble symptoms from faulty circuit, power, 1<sup>st</sup> low voltage circuit, high voltage circuit, etc..

1. ENGINE IS NOT STARTED OR HARD TO START.  
(CRANKING O.K.)

**A spark of spark plug is weak or not at all**

- 1) Check Ignition coil
- 2) Crankshaft position sensor
- 3) Spark plug

**A spark is normal**

Check ignition timing (Ignition timing is automatically controlled by ECU)

2. IDLING IS UNSTABLE
  - **Spark plug**
  - **Ignition timing**
  - **Ignition coil**
3. ACCELERATION IS INSUFFICIENT.
  - **Check Ignition timing**
4. ENGINE IS OVERHEATED AND FUEL CONSUMPTION IS EXCESSIVE.
  - **Check Ignition timing**

## INSPECTION OF IGNITION TIMING

1. Inspection condition
  - Coolant temperature : 80-90°C (At normal temperature)
  - Lamp, cooling fan and all accessories : OFF
  - Transaxle : In neutral position (Auto : N)
  - Parking brake : ON

2. Inspection
  - 1) Connect the timing light.
  - 2) After inserting the clip backward the connector, connect the tachometer with the special tool (09273-24000)

**⚠ CAUTION**

**Take care not to disconnect the connector.**

- 3) Measure RPM.

**RPM**

2.0DOHC	700 ± 100rpm
---------	--------------

**📖 NOTE**

**If RPM is not normal, it is impossible to measure the proper ignition timing, so measure it at a normal RPM.**

- 4) Inspect the standard ignition timing.

BTDC	2° ± 6°
------	---------

- 5) If ignition timing is out of the standard, inspect sensors concerned with ignition timing.

**⚠ CAUTION**

**Because ignition timing is fixed by set data value in ECU, it is impossible to control on purpose. First, check that sensors send output properly to help determine ignition timing control.**

**📖 NOTE**

**Affective ECU input to Ignition timing control**

1. **Coolant temperature sensor (WTS)**
2. **Oxygen sensor**
3. **Battery voltage**
4. **Vehicle speed sensor**
5. **Map sensor (Engine load)**
6. **Crankshaft position sensor**
7. **Throttle position sensor**
8. **Intake sensor**

- 6) Check that actual ignition timing is changed with engine RPM increased.

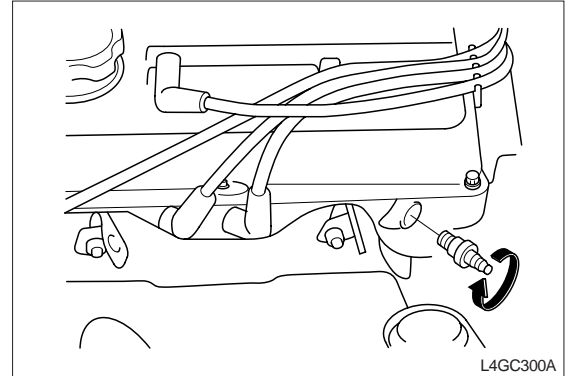

## INSPECTION OF IGNITION COIL

### 1. 1<sup>ST</sup> coil resistance measurement

Measure resistance between no.1 and no.3 terminals of ignition coil. (For no.1 and no.4 cylinders)

And measure resistance between no.3 and no.2 terminals of ignition coil. (For no.2 and no.3 cylinders)

#### 1A. 1<sup>ST</sup> coil resistance measurement

1 <sup>ST</sup> coil resistance	$0.5^{\circ} \pm 0.05\Omega$
---------------------------------	------------------------------

Measure resistance between no.1 and no.2 terminals of ignition coil.

### 2. 2<sup>ST</sup> coil resistance measurement

Measure resistance between high pressure terminals.

2 <sup>ST</sup> coil resistance	$12.1 \pm 1.8K\Omega$
---------------------------------	-----------------------

#### CAUTION

**When measuring 2<sup>nd</sup> coil resistance, remove the ignition coil connector.**

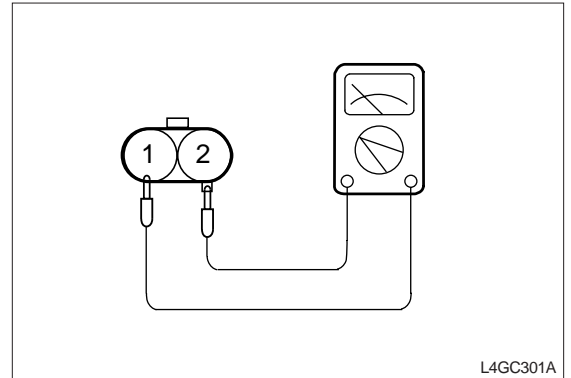

## INSPECTION OF SPARK PLUG

### Inspection and clean

1. Disconnect the spark plug cable from the spark plug.  
Remove the spark plug cable by pulling the cable cap with hand.
2. Remove all spark plugs from the cylinder head using a spark plug wrench.

**CAUTION**

*Take care not to come foreign materials into spark-plug mounting hole.*

3. Check the spark plug as below.
  - 1) Insulator broken
  - 2) Terminal worn
  - 3) Carbon deposit
  - 4) Gasket damaged or broken
  - 5) Porcelain insulator of spark plug clearance

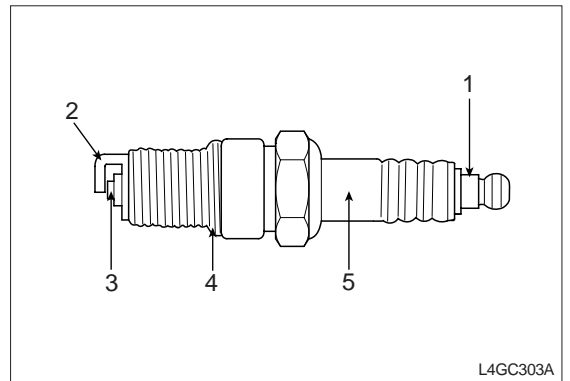
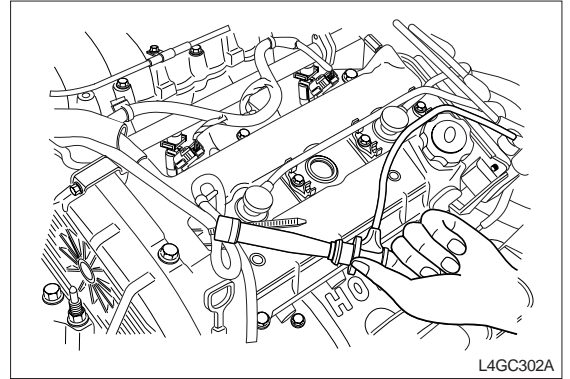

4. Check the plug clearance using a plug clearance gauge and if the value is not within the specified values, adjust it by bending the ground clearance. When installing a new spark plug, install it after checking the uniform plug clearance.

Spark plug clearance	0.7 ~ 0.8mm
----------------------	-------------

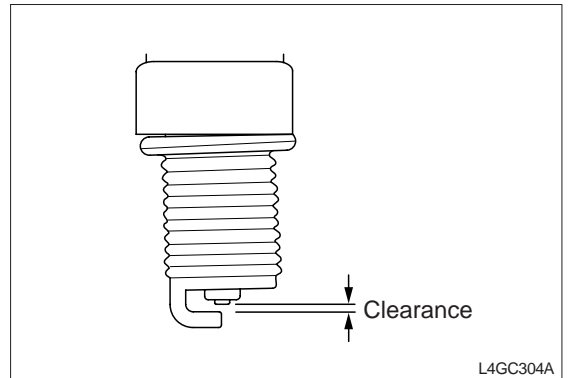

5. Install the spark plug and tighten it to the specified torque.  
Take care not to over tighten it to prevent cylinder head threads from damage.

<b>Tightening torque</b>	2 ~ 3kg·m
--------------------------	-----------

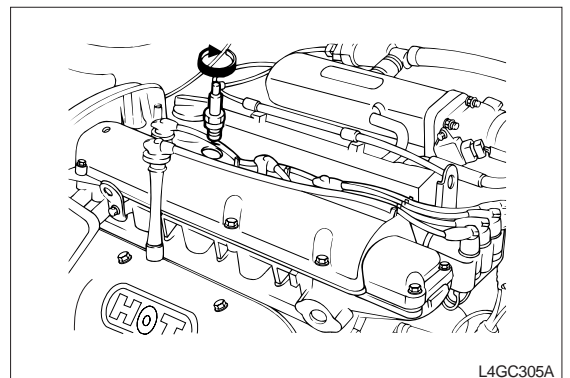

**SPARK PLUG ANALYSIS**

State	Contact point is black	Contact point is white
Description	<ul style="list-style-type: none"> <li>•Density of the fuel mixture is thick</li> <li>•Lack of air intake</li> </ul>	<ul style="list-style-type: none"> <li>• Density of the fuel mixture is thin</li> <li>•Ignition timing is fast</li> <li>•Spark plug is tight</li> <li>•Lack of torque</li> </ul>

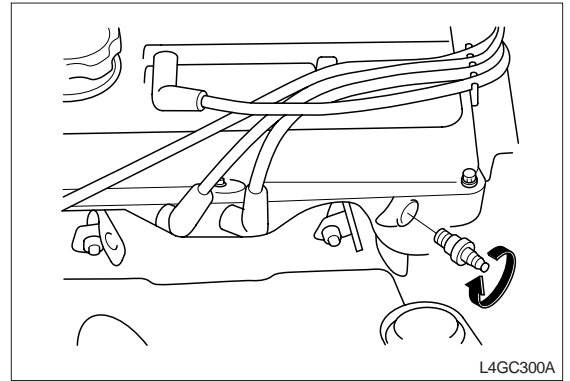

**SPARK PLUG TEST**

After connecting the spark plug to the high tension cable, connect the outer terminal(main body) to the ground and crank the engine. Because the discharging clearance is narrow in the air, only slight spark will arise. But if the spark plug is normal, spark arises at emission clearance (between terminals), and if the spark plug is defective, spark does not arise because insulation is damaged.

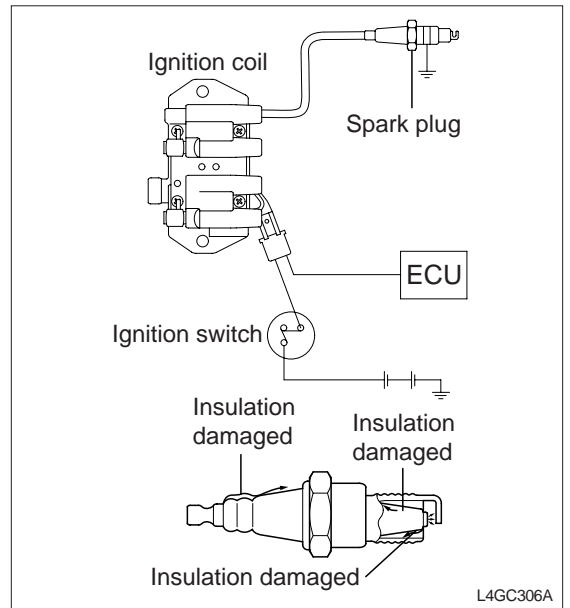

## SPARK PLUG CABLE

### INSPECTION

1. Check the cap for outer crack.
2. Measure resistance.
3. Inspect resistance.

#### Spark plug cable

NO.1	11.2k $\Omega$
NO.2	9.5k $\Omega$
NO.3	6.9k $\Omega$
NO.4	5.5k $\Omega$

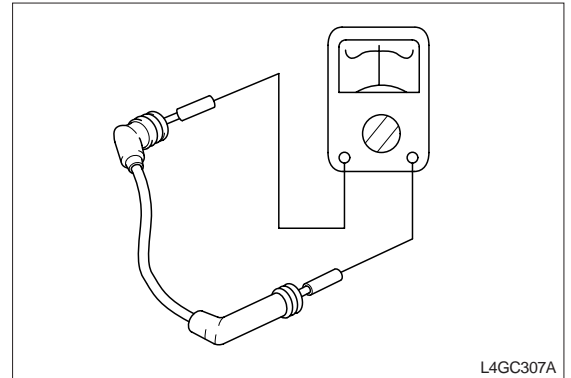

### TEST

1. With the engine at idle, disconnect the spark plug cable one by one and inspect change of the engine performance each time.



#### **CAUTION**

*At this time, put on the gloves.*

2. If engine performance is not changed, inspect the spark plug cable for resistance and the spark plug itself.

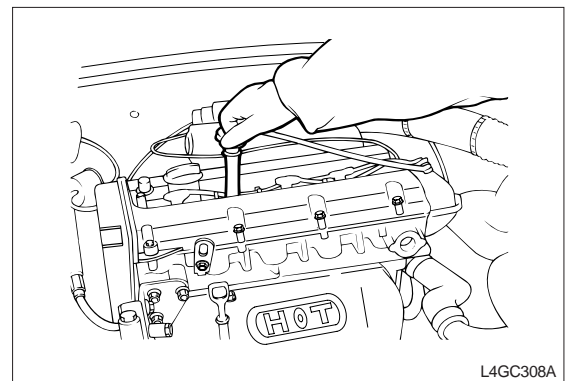

# CHARGING SYSTEM

## GENERAL

Charging system consists of battery, alternator with a built-in regulator, charging warning lamp and wire.

Because there are 6 diodes (3 (+) diodes, 3(-) diodes) built in alternator, AC current is rectified to DC current and DC current is detected in "B" terminal of alternator. Charging voltage from alternator is controlled by battery voltage detection unit.

Alternator consists of rotor, stator, rectifier, capacitor, brush, bearing, and V-ribbed pulley cover and Electronic voltage regulator is built in brush holder.

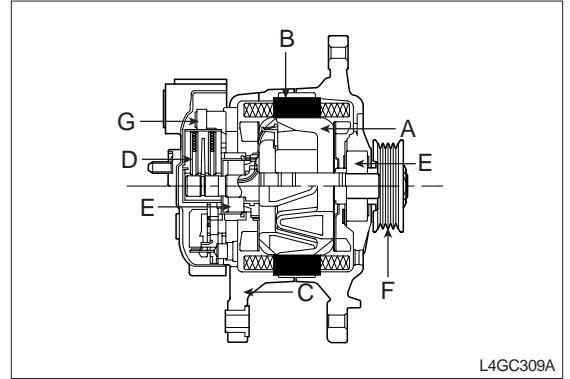

## COMPONENTS

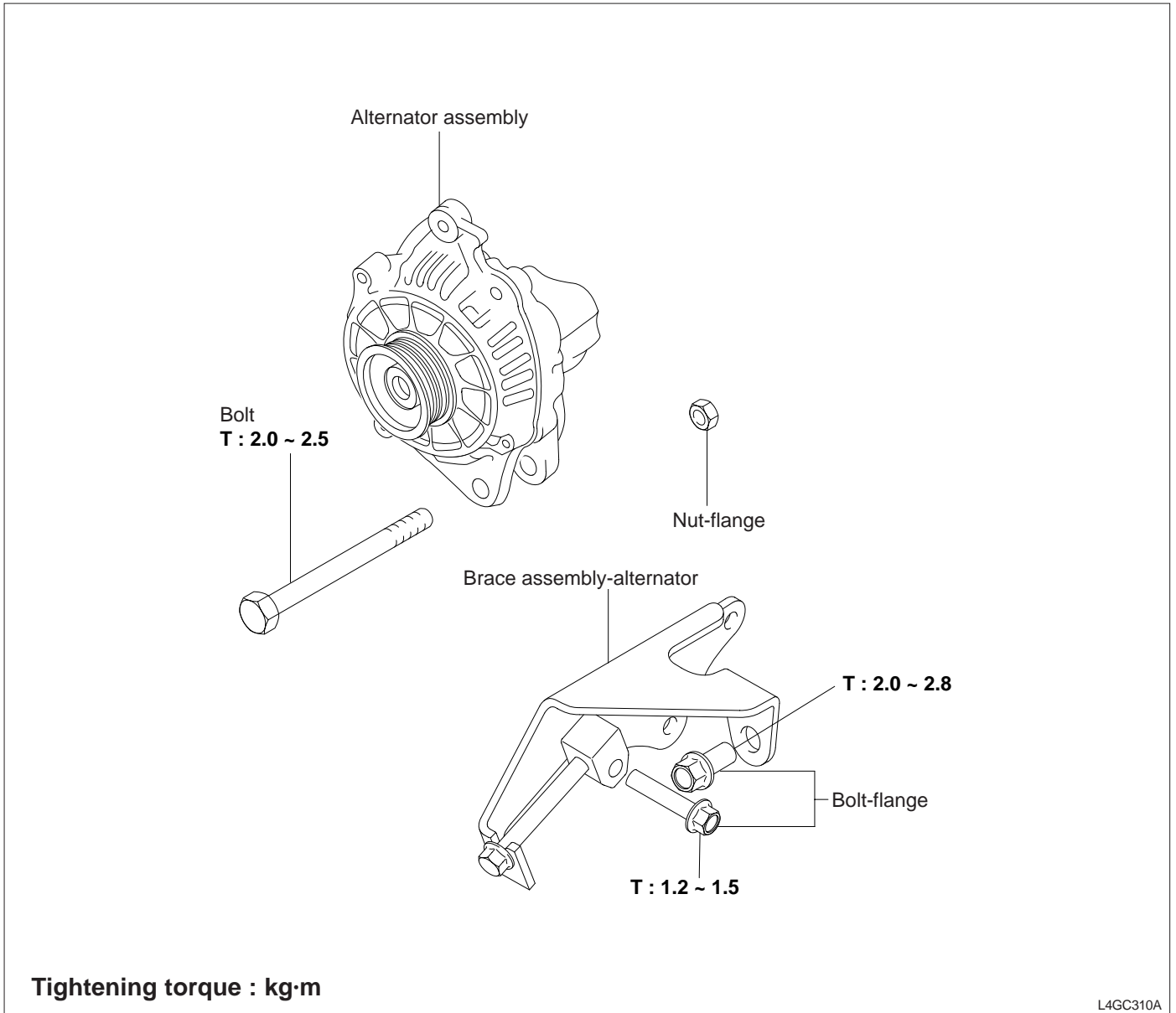



## TROUBLESHOOTING

Charging system defect is almost caused by lack of fan belt tension and faulty function of wiring, connector, and voltage regulator.

One of most important thing during troubleshooting of charging system is determining the reason between overcharging and lack of charging. So, prior to inspection of alternator, check the battery for charging. Faulty alternator causes the following symptoms.

1. Faulty battery charging
  - 1) IC regulator fault(Short circuit)
  - 2) Field coil fault
  - 3) Main diode fault
  - 4) Auxiliary diode fault
  - 5) Stator coil fault
  - 6) Brush contact fault
  
2. Overcharging : IC regulator fault(Short circuit)  
 Other faults such as voltage adjusting problem except above symptoms rarely happen.  
 Refer to the following troubleshooting table.

Symptom	Possible cause	Remedy
With ignition switch ON, charging warning lamp does not illuminate	Fuse cut off	Replace
	Bulb burnt out	Replace
	Loose wiring connection	Retighten
	Bad connection of L-S terminals	Inspect and replace wiring, Replace voltage regulator
With the engine started, warning lamp is not turned off (Battery needs often charging)	Loose or worn drive belt	Correct or replace
	Fuse cut off	Replace
	Fuse link cut off	Replace
	Faulty voltage regulator or alternator	Inspect alternator
	Faulty wiring	Repair
	Corrosion or wear of battery cable	Repair or replace
Overcharged	Faulty voltage regulator (Charging warning lamp illuminates)	Replace
	Voltage detection wiring fault	Replace
Battery is discharged	Loose or worn drive belt	Correct or replace
	Loose wiring connection	Retighten
	Short circuit	Repair
	Fusible link cut off	Replace
	Ground fault	Repair
	Faulty voltage regulator (Charging warning lamp illuminates)	Inspect alternator
	Battery out	Replace

TROUBLESHOOTING PROCEDURE

INSPECTION BEFORE STARTING

1. Charging warning lamp inspection

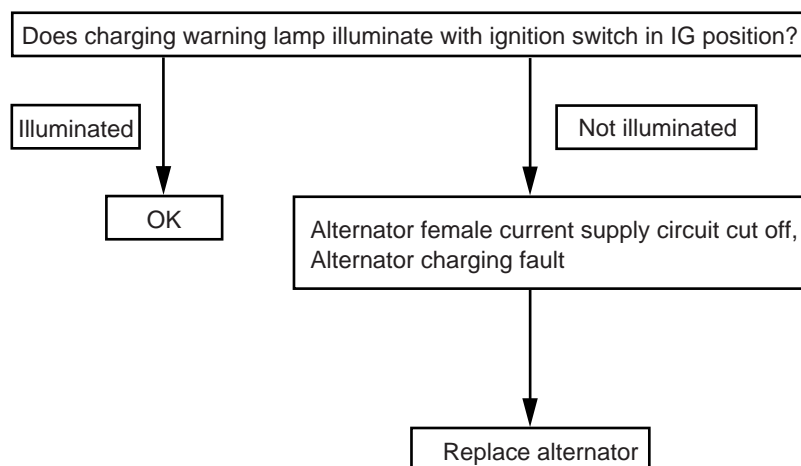

L4GC311A

2. Alternator and drive belt tension inspection

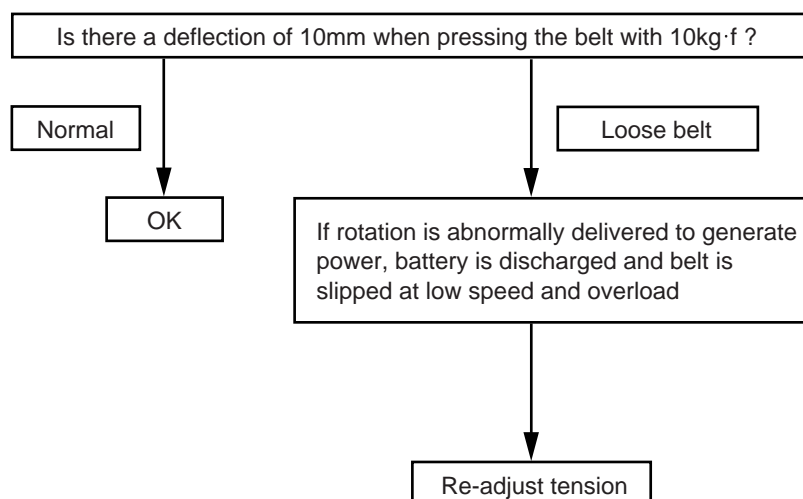

L4GC312A

3. Alternator and outer terminal connection inspection

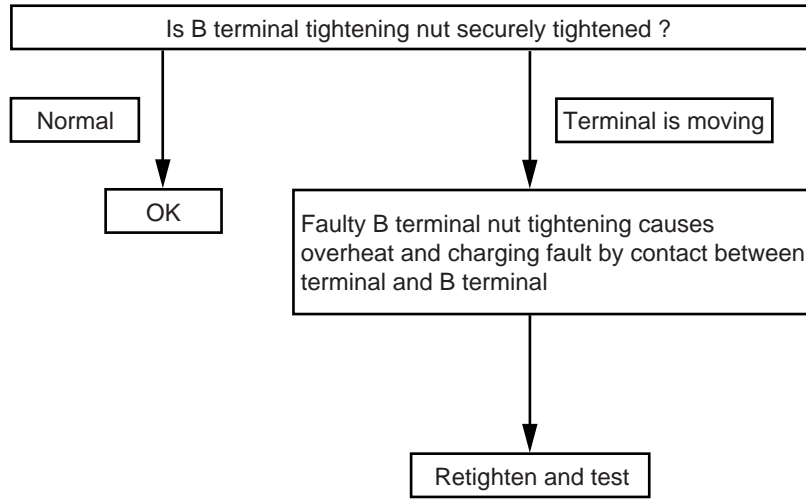

L4GC313A

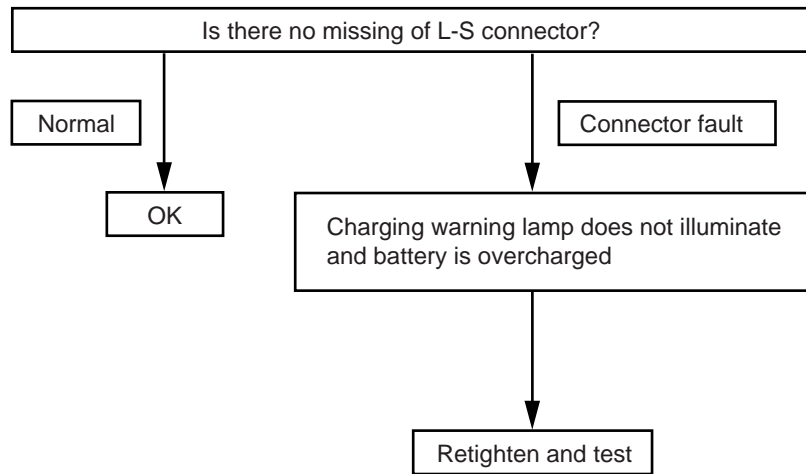

L4GC314A

4. Battery outer terminal inspection

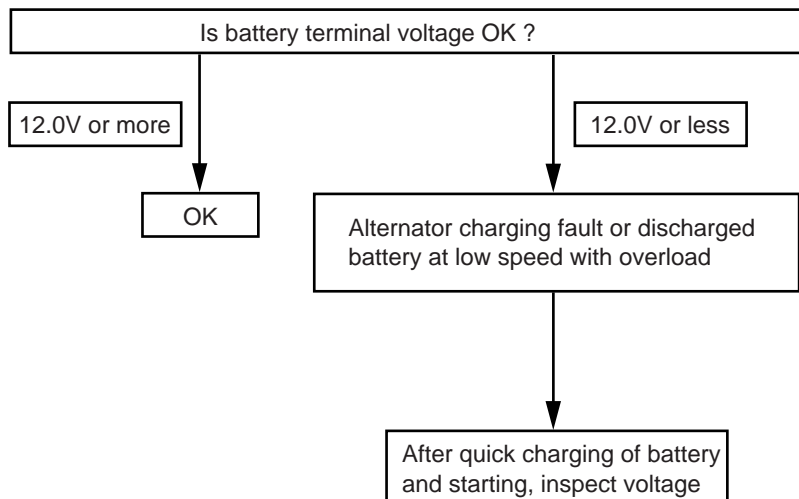

L4GC315A

INSPECTION AFTER STARTING

1. Inspection of alternator charging warning lamp operation test

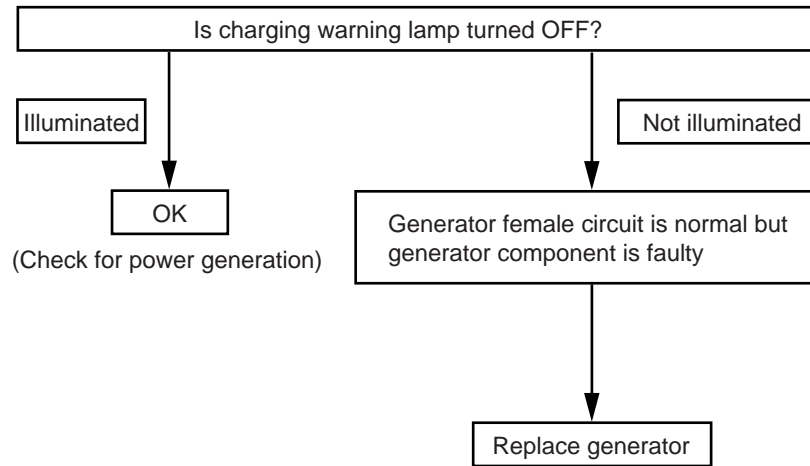

L4GC317A

2. When starting, belt slip and noise inspection

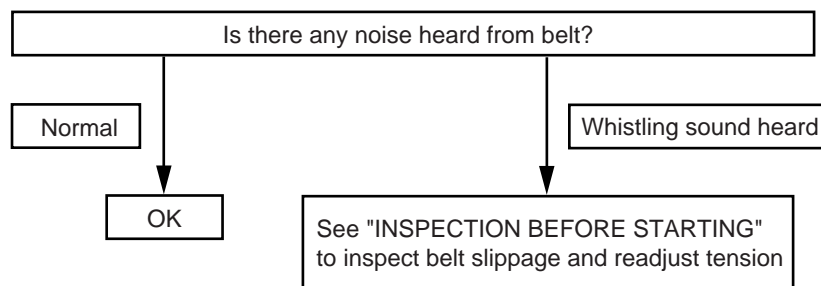

L4GC318A

3. Inspection of battery voltage at idling  
(At this time charge battery only)

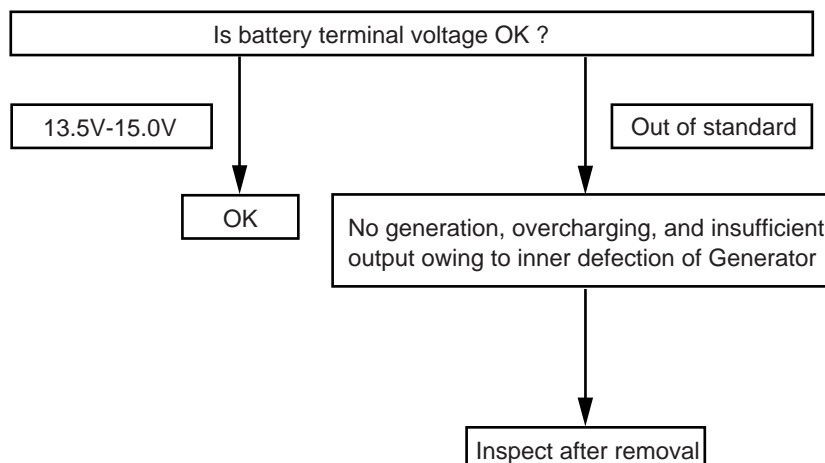

L4GC319A

## DROP OF ELECTRIC PRESSURE TEST OF ALTERNATOR OUTPUT WIRE

This test is to check that wiring is correctly connected between the alternator "B" terminal and battery (+) terminal.

### PREPARATION

1. Turn the ignition switch OFF.
2. Disconnect the battery ground cable.
3. Disconnect the alternator output wire from the alternator "B" terminal.
4. Connect a DC ampere meter (0-100A) between the terminal and the disconnected output wire.  
Connect (+) lead wire to the terminal "B" and (-) lead wire to the disconnected output wire.

#### NOTE

***In case of using a clamp type ammeter, it is possible to measure current without disconnecting the harness.***

5. Connect a digital voltmeter between the alternator "B" terminal and the battery (+) terminal.  
Connect (+) lead wire to the terminal "B" and (-) lead wire to the battery (+) terminal.
6. Connect the battery ground cable.
7. Be sure that the hood is opened.

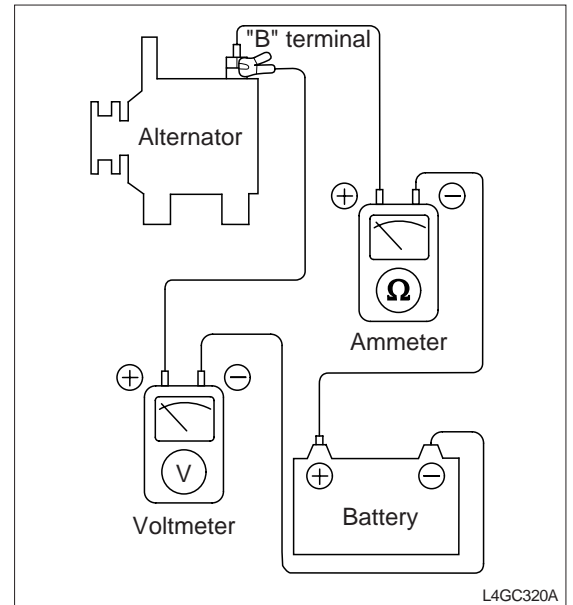

### TEST

1. Start the engine.
2. Repeating ON and OFF of headlight and small light, adjust the engine speed until an ammeter reads 20A and at that time measure voltage.

## RESULT

1. If voltmeter reading is within the standard, it is normal.

Test voltage	Maximum 0.2V
--------------	--------------

2. If voltmeter reading is more than the standard, mostly wiring is faulty. In this case, inspect wirings between the alternator and the battery (+) terminal as well as between the alternator “B” terminal and the fusible link.
3. Also prior to re-test, check and repair the connecting part for looseness and the harness for discoloration by overheating.
4. After test, adjust the engine speed at idle and turn the light and ignition switch OFF.
5. Disconnect the battery ground cable.
6. Disconnect the ammeter and voltmeter.
7. Connect the alternator output lead wire to the alternator “B” terminal.
8. Connect the battery ground cable.

## OUTPUT CURRENT TEST

This test is to check that the alternator output current is identified with the rated current.

## PREPARATION

1. Prior to test, inspect the following items and repair if necessary.

- 1) Be sure that the battery installed in the vehicle is normal.(See “Battery” )

 **NOTE**

***When measuring output current, necessarily use a slightly discharged battery. Fully charged battery is not enough to use for correct test owing to insufficient load.***

- 2) Inspect the drive belt for tension. (See “Engine body” )
2. Turn the ignition switch OFF.
3. Disconnect the battery ground cable.
4. Disconnect the alternator output wire from the alternator “B” terminal.

- Connect a DC ampere meter (0-100V) between "B" terminal and the disconnected output wire.  
Connect (+) lead wire to the terminal "B" and (-) lead wire to the disconnected output wire.

**NOTE**

***Do not use clips or equivalent owing to high current and Use bolts and nuts to tighten each connecting part securely.***

- Connect a voltmeter(0-20V) between "B" terminal and the ground.  
Connect (+) lead wire to the alternator "B" terminal and (-) lead wire to the proper position.
- Connect the engine tachometer and then battery ground cable.
- Be sure that the hood is opened.

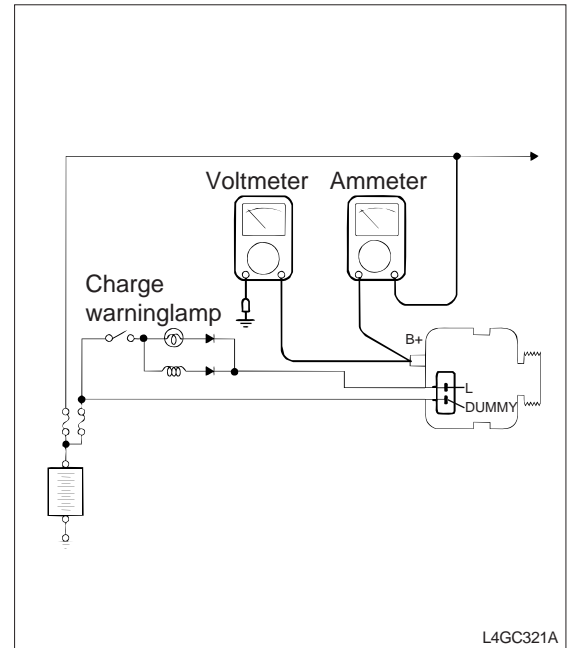

## TEST

- Be sure that voltmeter reading is identified with battery voltage.  
If voltmeter reading is 0V, it means short circuit of wire between "B" terminal and the battery (-) terminal, fusible link cut off or ground fault.
- Turn the headlight ON and start the engine.
- With the engine running at 2,500 rpm, turn ON the high beam headlights, place the heater blower switch at "HIGH" measure the maximum output current using an ammeter.

**NOTE**

***This test should be done as soon as possible to measure the exact maximum current because output current drops rapidly after starting the engine.***

**RESULT**

1. Ammeter reading should be higher than the limit. If the reading is low even though the alternator output wire is normal, remove the alternator from the vehicle and inspect it.

Output current limit	70% of rated current
----------------------	----------------------

**NOTE**

- **The rated output current is represented on the name plate in the alternator body.**
- **Output current varies according to electrical load or temperature of the alternator, so during test, lack of electrical load causes impossibility of measuring the rated output current. In this case, turn on headlight to induce the battery discharging or turn on other lights to increase the electrical load. If alternator temperature or ambient temperature is too high, it is impossible to measure the rated output current, so prior to re-test, necessarily drop the temperature.**

Ambient temperature of voltage regulator (°C)	Voltage adjust (V)
-20	14.2 ~ 15.4
20	13.8 ~ 15.0
60	13.4 ~ 14.6
80	13.2 ~ 14.4

2. After test, adjust the engine speed at idle and turn the light and ignition switch OFF.
3. Disconnect the battery ground cable.
4. Disconnect the ammeter and voltmeter.
5. Connect the alternator output lead wire to the alternator "B" terminal.
6. Connect the battery ground cable.



## DISASSEMBLY AND INSTALLATION

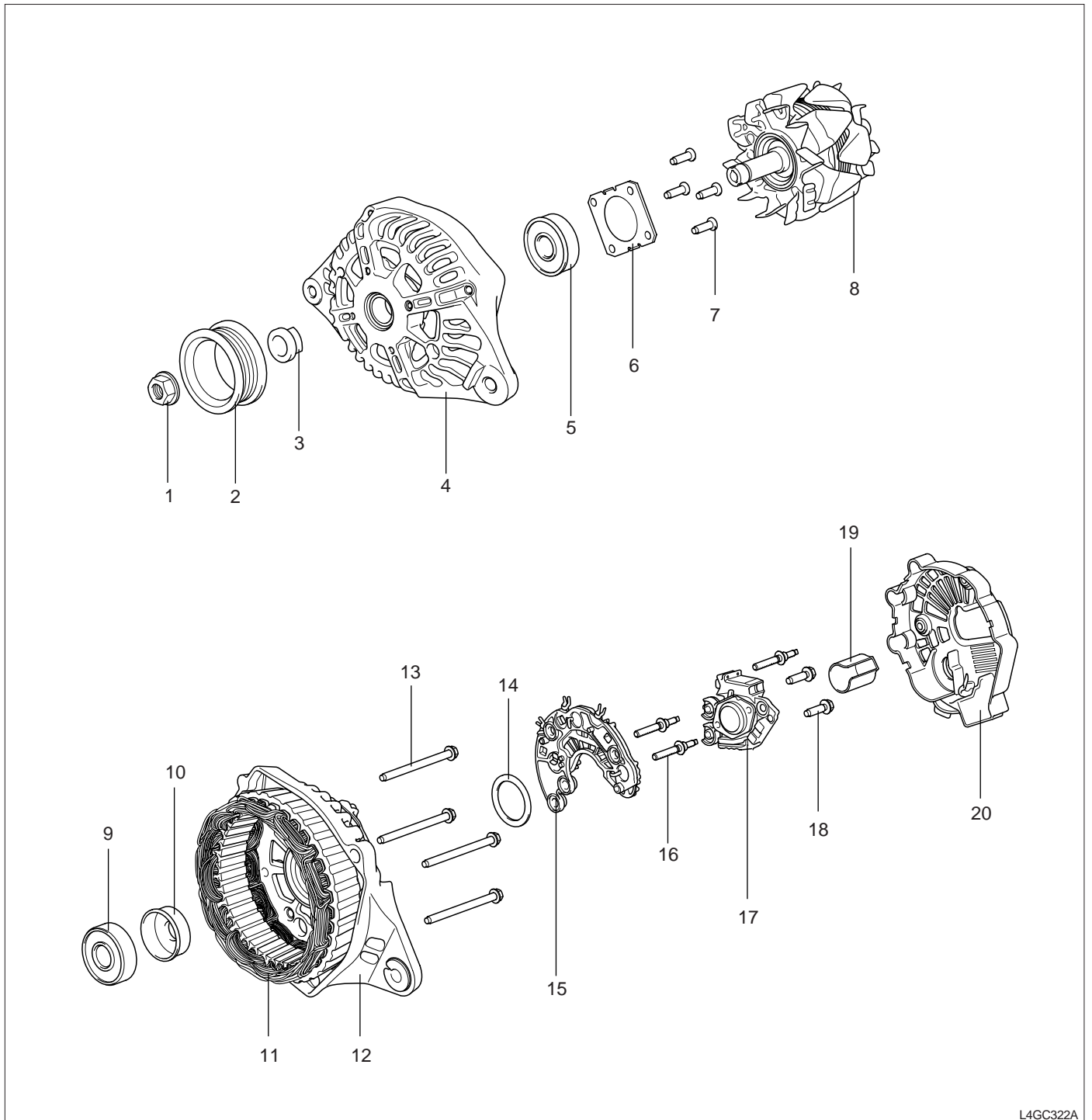

L4GC322A

- |                         |                   |                           |
|-------------------------|-------------------|---------------------------|
| 1. Nut                  | 8. Rotor coil     | 15. Rectifier assembly    |
| 2. Pulley               | 9. Rear bearing   | 16. Stud bolt             |
| 3. Bushing              | 10. Bearing cover | 17. Brush holder assembly |
| 4. Front cover assembly | 11. Stator coil   | 18. Brush holder bolt     |
| 5. Front bearing        | 12. Rear cover    | 19. Slip ring guide       |
| 6. Bearing cover        | 13. Through bolt  | 20. Cover                 |
| 7. Bearing cover bolt   | 14. Seal          |                           |

**REMOVAL AND INSTALLATION**

1. Disconnect the battery (A) terminal.

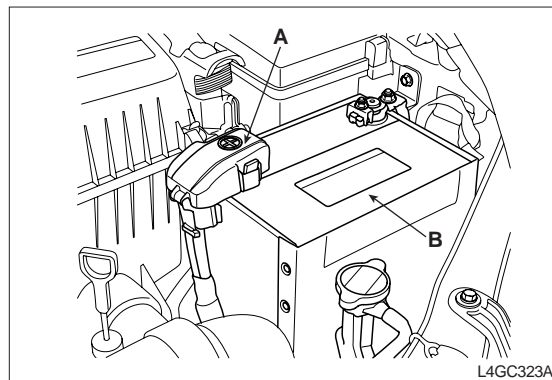

2. Disconnect the alternator "B" terminal and then the connector (A). Loosen the clip (B).

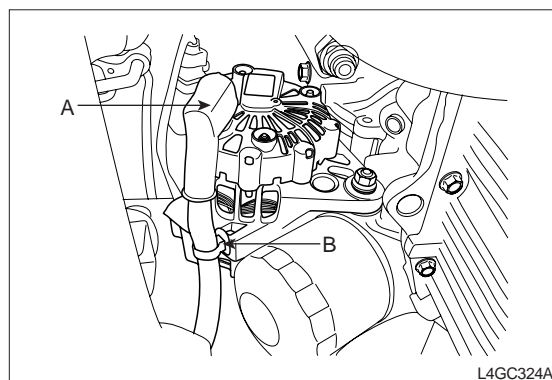

3. Loosen the alternator tension adjusting bolt (A) and the alternator fixing bolt (B).

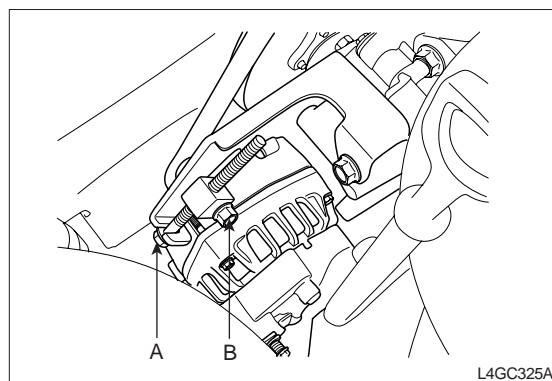

4. Remove the belt by pressing inward the alternator.
5. Remove the alternator bracket.
6. Loosen the mounting and remove the alternator assembly.
7. Installation is reverse order of removal.

**DISASSEMBLY**

1. After removing the mounting nuts (B), remove the generator cover (A) using a screwdriver.

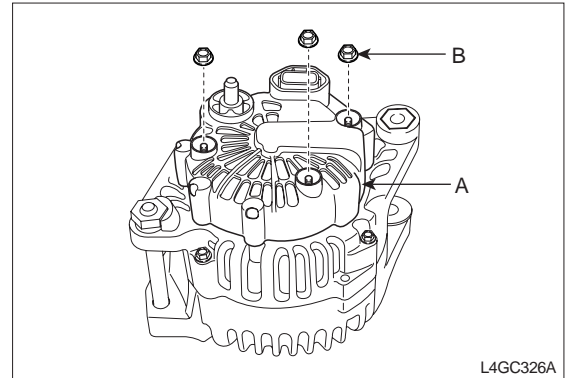

2. Loosen 3 mounting bolts (A) and disconnect the brush holder assembly (B).

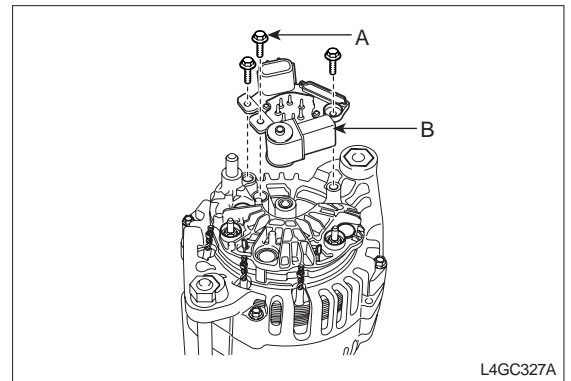

3. Remove the slip ring guide (A).

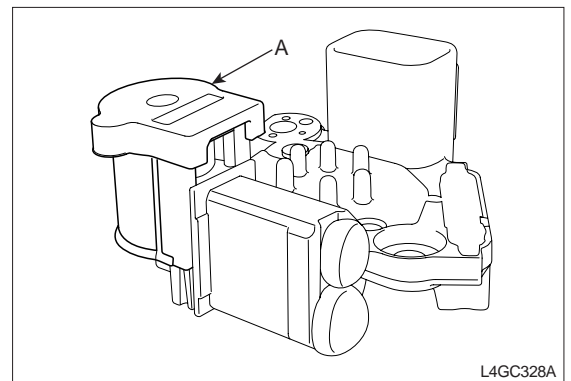

4. Remove the nut, pulley and spacer.

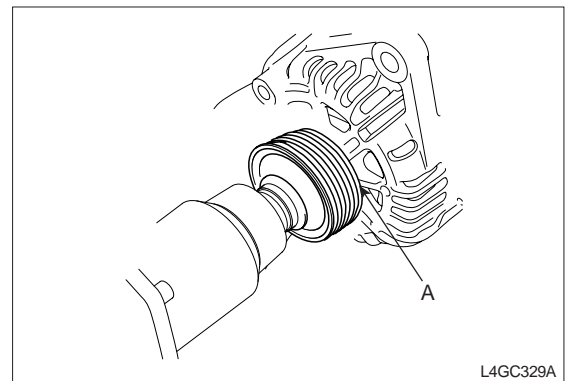

5. Loosen 4 through bolts.

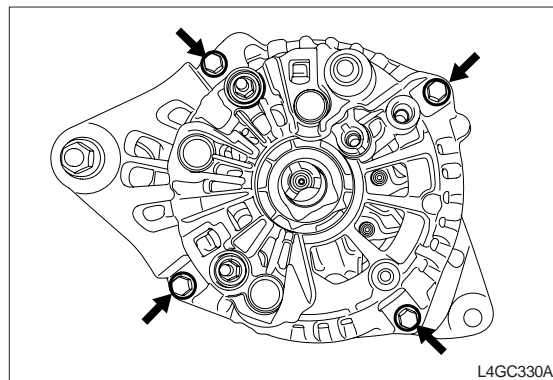

6. Separate the rotor and cover.

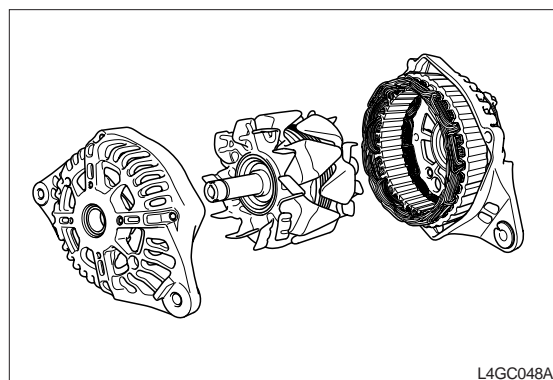

## INSPECTION

### ROTOR

1. Inspect the rotor coil for continuity and check for continuity between slip rings.

If resistance is too low, circuit is short and if the resistance is too high, circuit is opened. So replace the rotor assembly in both cases.

Resistance value	2.5 ~ 3.0Ω(20°C)
------------------	------------------

2. Inspect the rotor coil ground and check continuity between the slip ring and the core. If there is continuity, replace the rotor assembly.

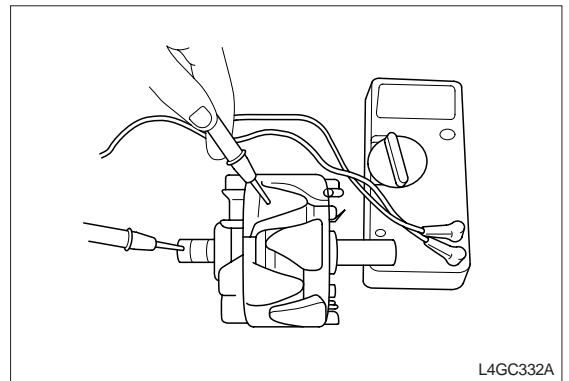
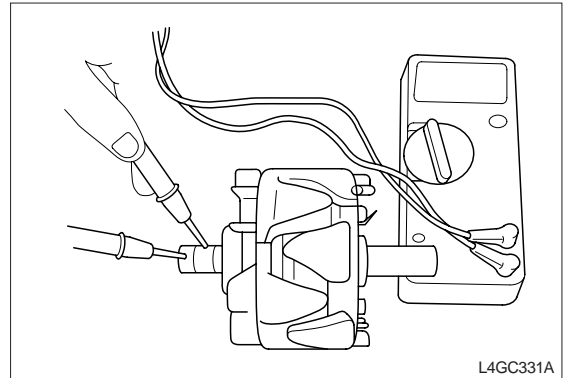

### STATOR

1. Inspect the stator coil for continuity and check continuity between the coil leads. If there is no continuity, replace the stator assembly.

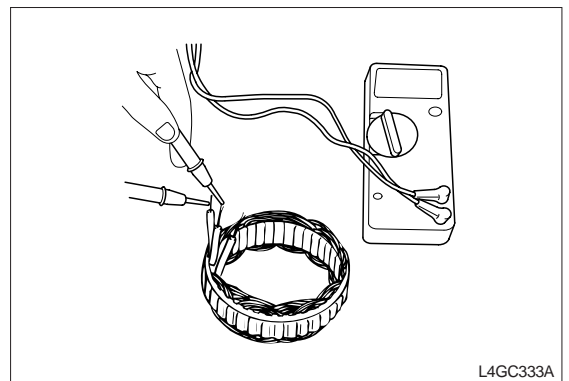

2. Inspect the coil ground and check continuity between the coil and the core. If there is continuity, replace the stator assembly.

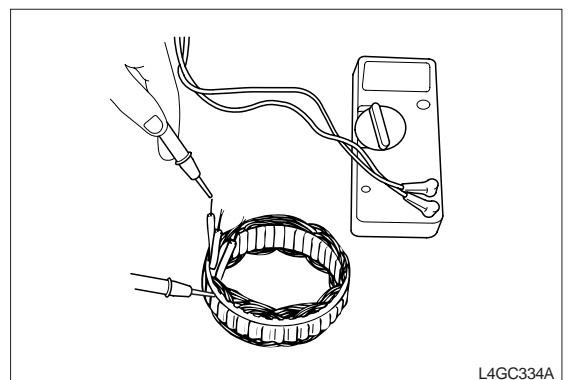

## RECTIFIER

### 1. (+) rectifier

When inspecting continuity between (+) rectifier and stator coil lead connecting terminal using an ohmmeter, there must have only one direction continuity. If there is both direction continuity, replace the rectifier assembly owing to short circuit of diode.

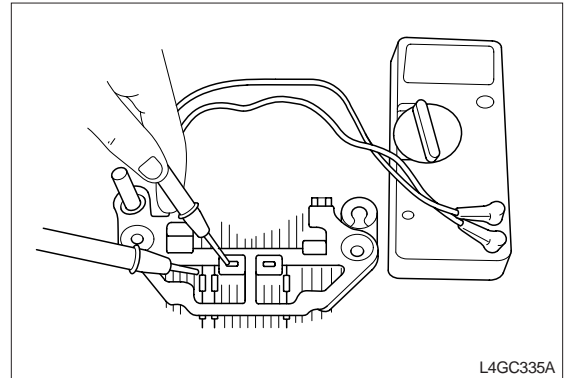

### 2. (-) rectifier

When inspecting continuity between (-) rectifier and stator coil lead connecting terminal using an ohmmeter, there must have only one direction continuity. If there is both direction continuity, replace the rectifier assembly owing to short circuit of diode.

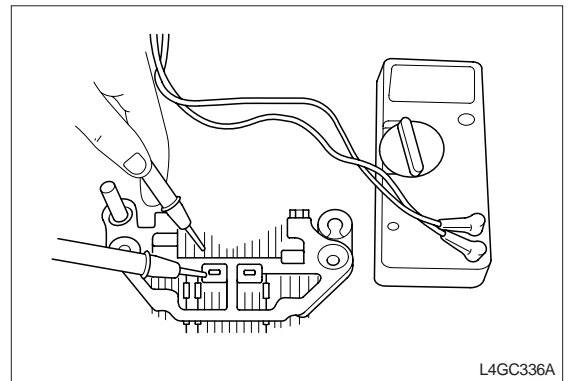

## BRUSH REPLACEMENT

If the brush is worn out to the limit, replace the brush as the following order.

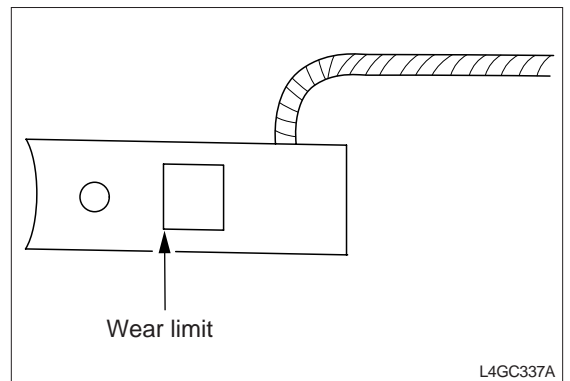

## INSTALLATION

Installation is the reverse order of disassembly. Take care of the following items.

1. Before installing the rotor to the bracket, insert the wire into the small bore of rear bracket and fix the brush.
2. After installing the rotor, remove the wire.

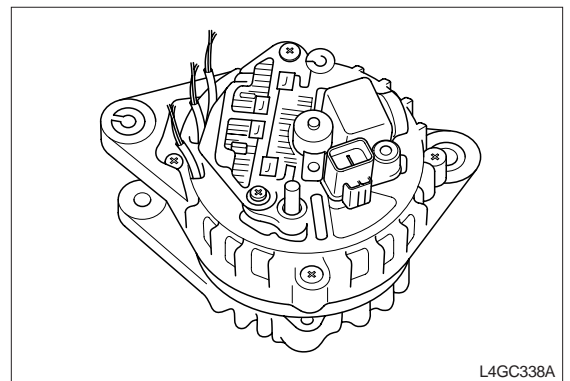

**INSTALLATION**

1. After placing the alternator, insert the support bolt. (At this time do not insert the nut.)
2. After pressing forward the alternator, Contact the alternator front bracket with front case (A) as shown in the illustration.
3. Insert and install the nut by tightening it to the specified torque.

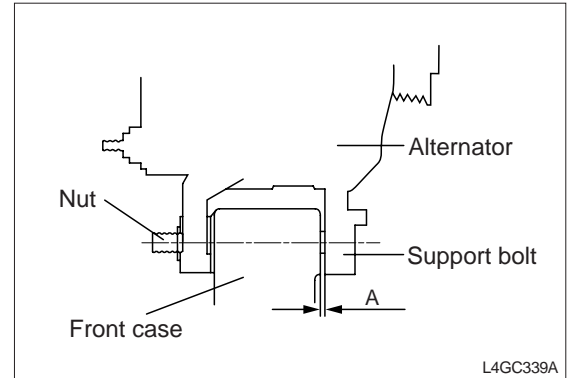

# STARTING SYSTEM

## GENERAL

Starting system consists of battery, start motor, solenoid switch, ignition switch, inhibitor switch (Only for A/T), contact wire, and battery case. When the ignition key is turned to "ST" position, current is sending to start motor solenoid coil, the solenoid plunger and clutch shift lever is actuated, and the clutch pinion is engaged with the ring gear resulting in cranking.

When starting the engine, the clutch pinion is overrun to prevent the armature coil from damage by excessive rotation.

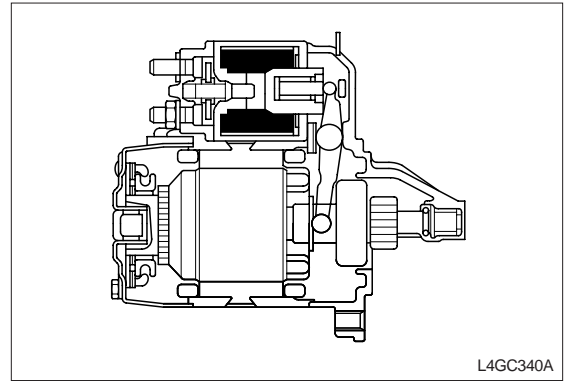

## COMPONENTS

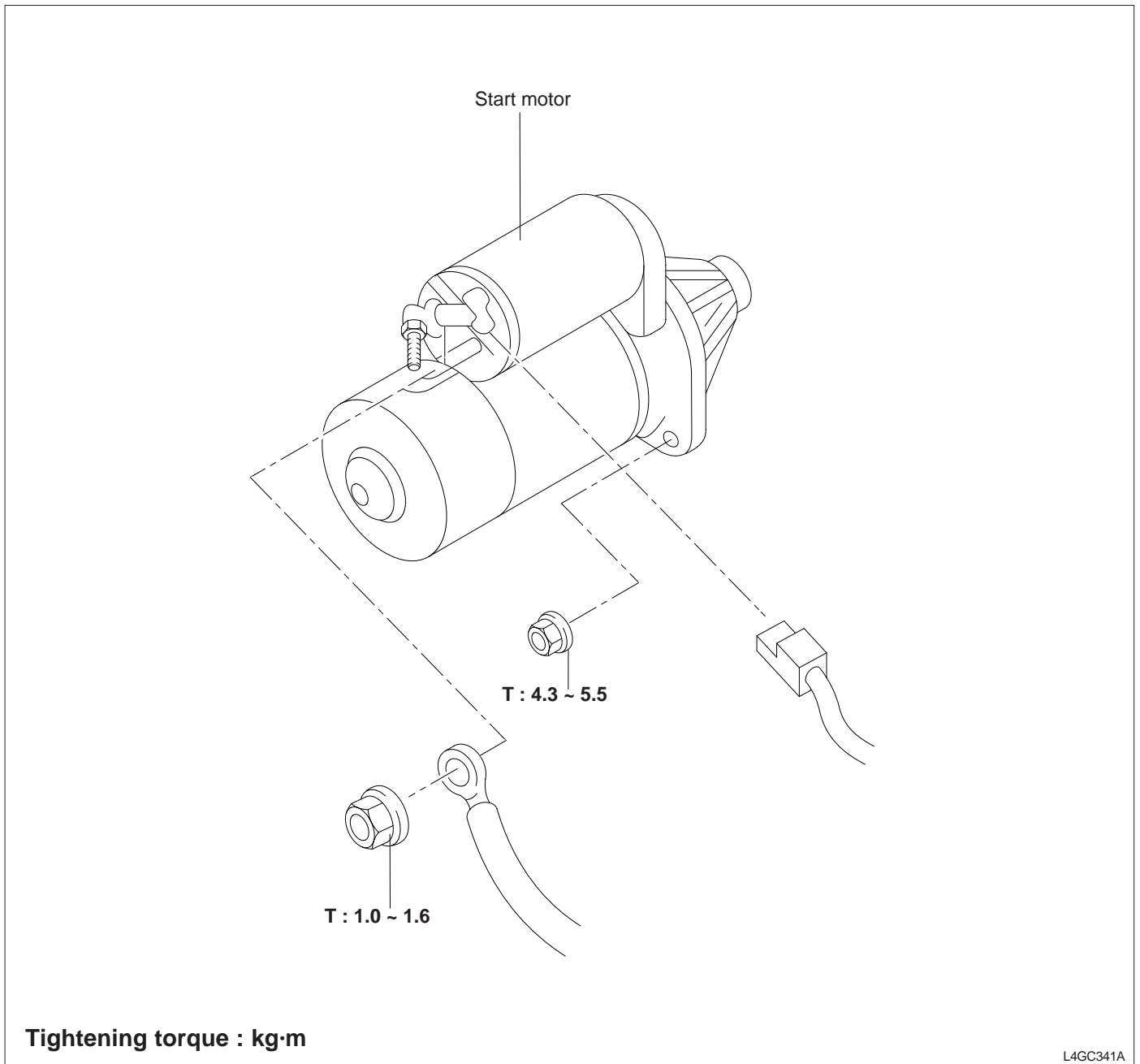



### TROUBLESHOOTING

Starting system problem can be classified into “Start motor is not operating”, “Start motor is operating but engine is not starting”, and “There is a lot of time taken to start engine”.

When the starting system has problems, before removing the start motor, find where the problem happens. Generally if it is difficult to start, there are problems in ignition system, fuel system, and electrical system. In this case, necessarily inspect and repair step by step, or the same problem will happen.

Symptom	Possible cause	Remedy
Impossible cranking	Low battery charging voltage	Charge or replace
	Loose, corroded or worn battery cable	Repair or replace
	Inhibitor switch fault (With A/T)	Adjust or replace
	Short circuit of fusible link	Replace
	Start motor fault	Repair
	Ignition switch fault	Replace
Slow cranking	Low battery charging voltage	Charge or replace
	Loose, corroded or worn battery cable	Repair or replace
	Start motor fault	Repair
Continuous rotating of start motor	Start motor fault	Repair
	Ignition switch fault	Replace
Start motor is rotating but engine is not cranking	Short circuit of wiring	Repair
	Worn or broken pinion gear tooth or motor fault	Repair
	Worn or broken ring gear tooth	Replace flywheel ring gear or torque converter

### START MOTOR

#### REMOVAL AND INSTALLATION

1. Disconnect the battery ground cable.
2. Remove the speedometer cable.
3. Separate the start motor connector and terminal.
4. Remove the start motor assembly.
5. Installation is the reverse of removal.

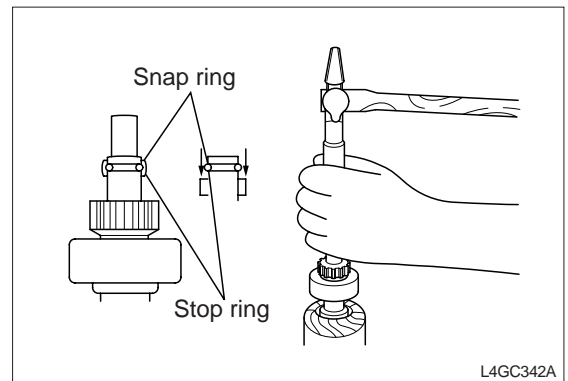

L4GC342A

COMPONENTS

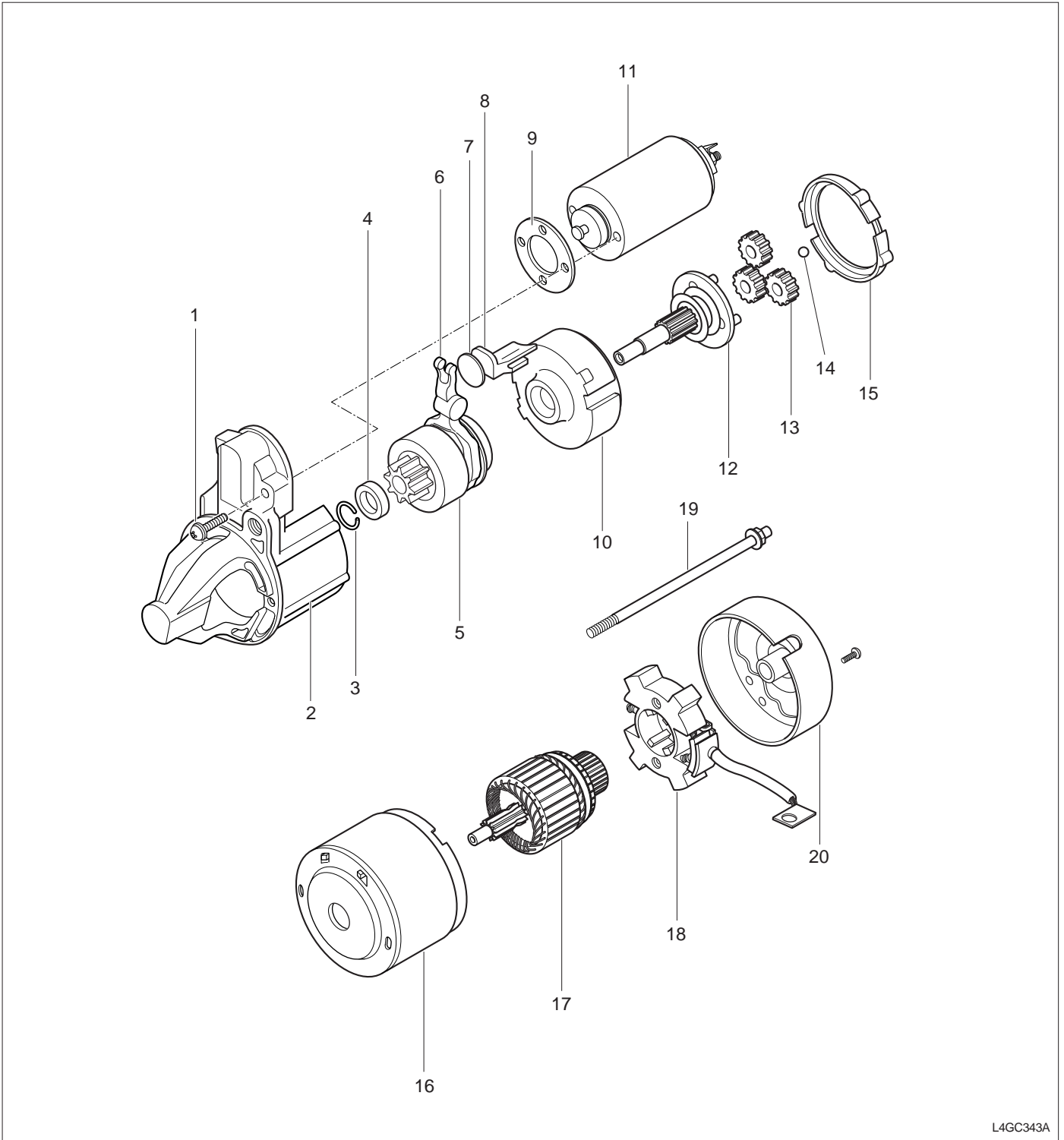

L4GC343A

- |                       |                   |                           |                   |
|-----------------------|-------------------|---------------------------|-------------------|
| 1. Screw              | 6. Lever          | 11. Magnetic switch       | 16. Yoke assembly |
| 2. Front bracket      | 7. Plate          | 12. Planetary gear holder | 17. Armature      |
| 3. Stop ring          | 8. Packing B      | 13. Planetary gear        | 18. Brush holder  |
| 4. Stopper            | 9. Shim           | 14. Ball                  | 19. Through bolt  |
| 5. Overrunning clutch | 10. Internal gear | 15. Packing A             | 20. Rear bracket  |

**INSPECTION (AFTER REMOVAL)**

**INSECTION OF PINION CLEARANCE**

1. Disconnect the wire from “M” terminal.
2. Connect a 12V battery between “S” terminal and “M” terminal.
3. If the switch is turned ON, the pinion is moving.

**⚠ CAUTION**

*This test should be done as soon as possible not to damage the coil (in 10 seconds).*

4. Measure clearance between the pinion and stopper using a feeler gauge. If the measured value is out of the standard, adjust clearance by adding or removing the washer between the magnetic switch and front bracket.

Pinion clearance	0.5 ~ 2.0mm
------------------	-------------

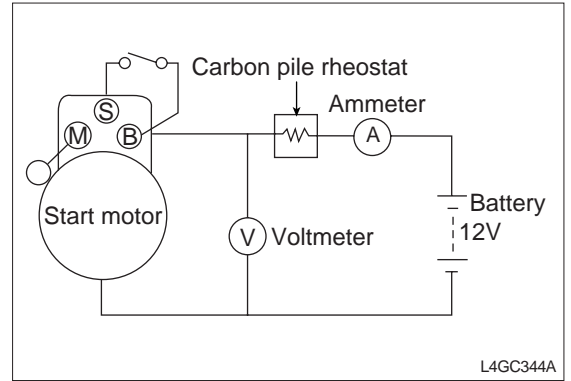

L4GC344A

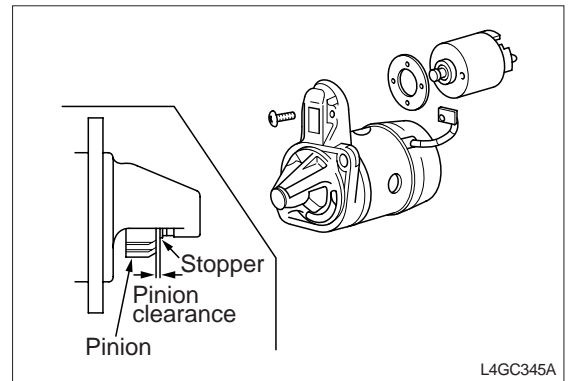

L4GC345A

**PULL IN TEST OF MAGNETIC SWITCH**

1. Disconnect the connector from “M” terminal.
2. Connect a 12V battery between “S” terminal and “M” terminal.

**⚠ CAUTION**

*This test should be done as soon as possible not to damage the coil (in 10 seconds).*

3. If the pinion is moving outward, the coil is normal, if or not, replace the magnetic switch.

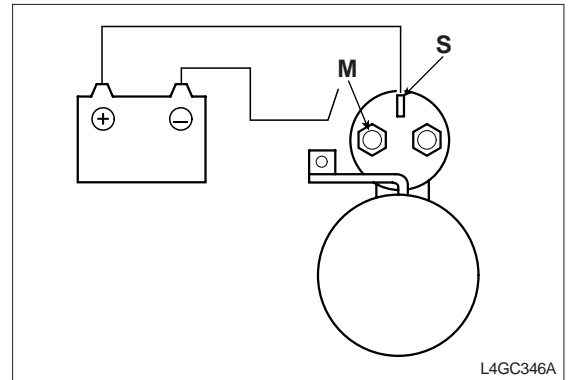

L4GC346A

**HOLD IN TEST OF SOLENOID**

1. Disconnect the connector from “M” terminal.
2. Connect a 12V battery between “S” terminal and “M” terminal.

**⚠ CAUTION**

*This test should be done as soon as possible not to damage the coil (in 10 seconds).*

3. If the pinion is moving outward, the coil is normal, if the pinion is moving inward, replace the magnetic switch owing to open-circuit.

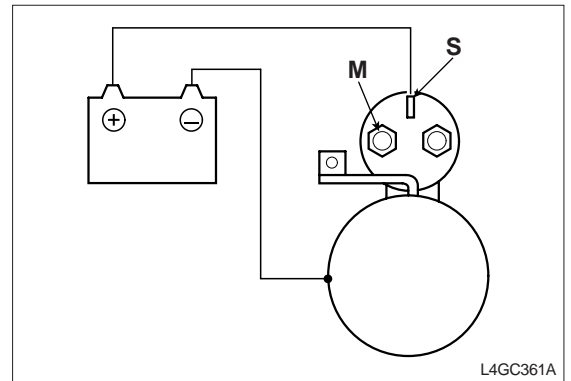

L4GC361A

**RETURN TEST OF SOLENOID**

1. Connect the connector from “M” terminal.
2. Connect a 12V battery between “S” terminal and “M” terminal.

**CAUTION**

*This test should be done as soon as possible not to damage the coil (in 10 seconds).*

3. When releasing after pulling the pinion outward, if the pinion is returned to native position, it is normal, if or not, replace the solenoid valve.

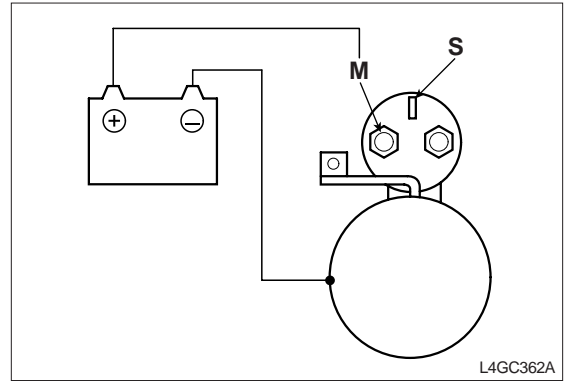

**PERFORMANCE TEST (WITH NO-LOAD)**

1. Connect a 12V battery to the start motor.
2. To operate the start motor with no load, turn the switch ON. If the operating speed and current measured are identified with the standard, the start motor is normal. If the operating speed is insufficient or the current is excessive, it is because of excessive friction resistance. And the low current or lack of operating speed is because of faulty contact or open circuit between the brush and the rectifier or between the welding points.

Speed	Minimum 3,000rpm
Current	Maximum 60A or less

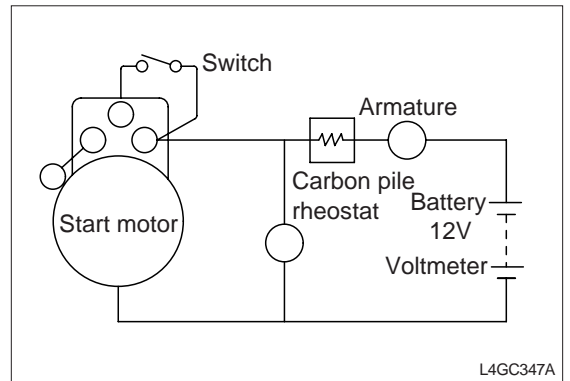

**DISASSEMBLY**

To remove the overrunning clutch from the armature shaft, remove the stop ring. Remove the stop ring by moving it to the pinion side, and then remove the stop ring from the shaft.

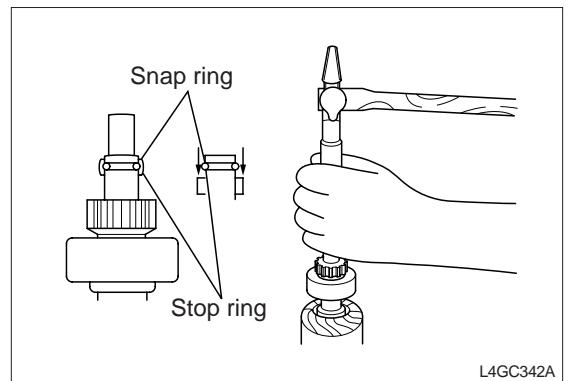

**INSPECTION (AFTER DISASSEMBLY)**

1. GROUND TEST OF ARMATURE COIL  
Check continuity between the commutator and the armature coil using a circuit tester. If there is continuity, replace the rotor assembly.

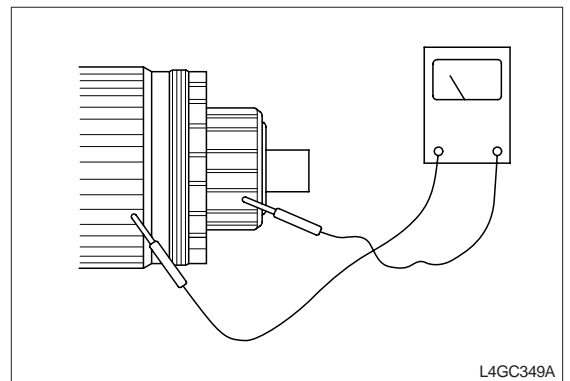

### 2. SHORT CIRCUIT TEST OF AMARTURE COIL

Inspect the armature coil in the growler and if there is short circuit, replace the coil. During core rotation, if the blade attached in the core is vibrated, the armature is short.

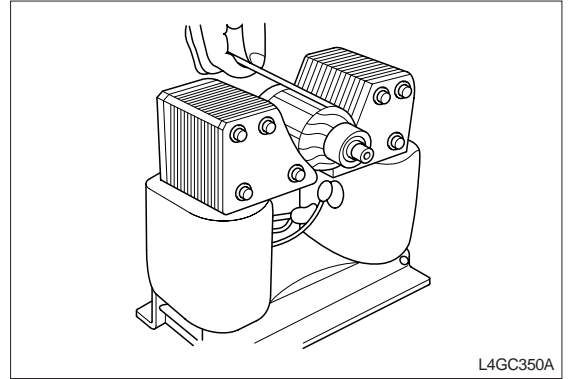

### 3. OPEN CIRCUIT TEST OF ARMATURE COIL

Check continuity between the commutator segments using a circuit tester. If there is no continuity, replace the armature assembly owing to open circuit of commutator segment.

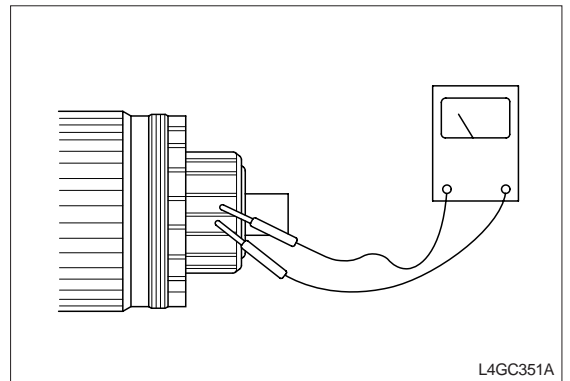

### 4. OPEN CIRCUIT TEST OF FIELD COIL

Check continuity of the field coil using a circuit tester. If there is no continuity, replace the field coil assembly owing to open circuit of the field coil.

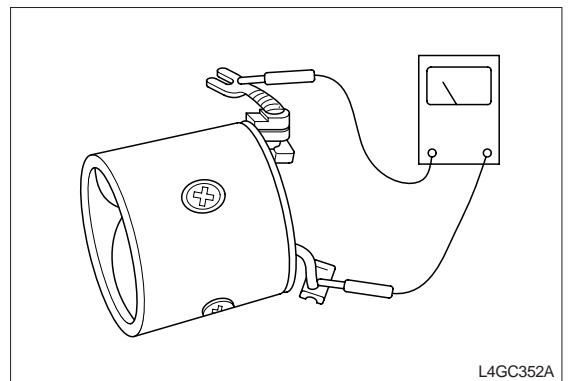

### 5. GROUND TEST OF FIELD COIL

With the yoke field coil installed, inspect continuity between the field coil and the yoke, if there is continuity, replace the field coil.

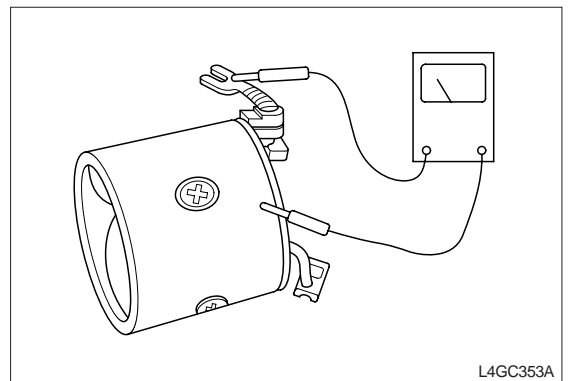

## 6. BRUSH

If the brush is worn out to the limit, replace the brush.

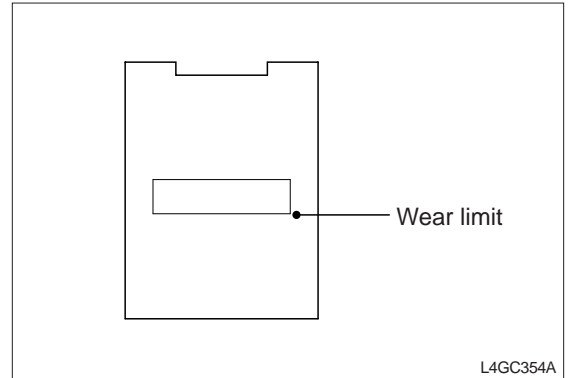

## 7. BRUSH HOLDER

Check continuity between the (+) side brush holder and the base. If there is continuity, replace the brush holder assembly.

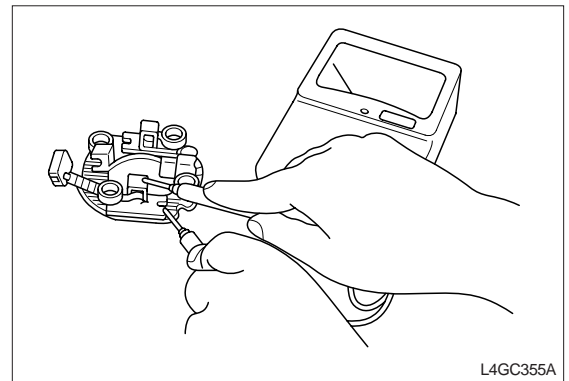

## 8. OVERRUNNING GLUTCH

- 1) Check the pinion and spline teeth for wear and damage and replace it if necessary. Also, inspect the flywheel for wear and damage.
- 2) Rotate the pinion. The pinion must be rotated clockwise but counterclockwise.

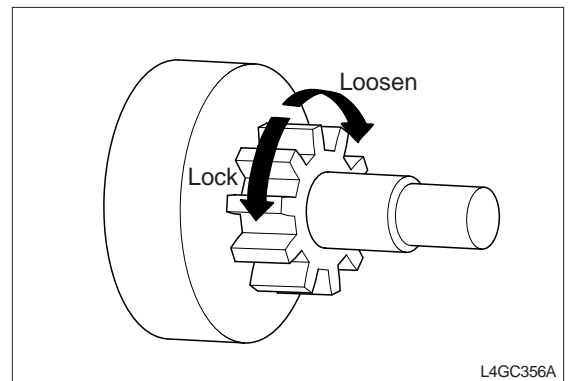

## 9. BRUSH REPLACEMENT

- 1) Remove the worn brush taking care not to damage the pigtail.
- 2) For better welding, correct the pigtail end with a sand paper.
- 3) Weld the pigtail end.

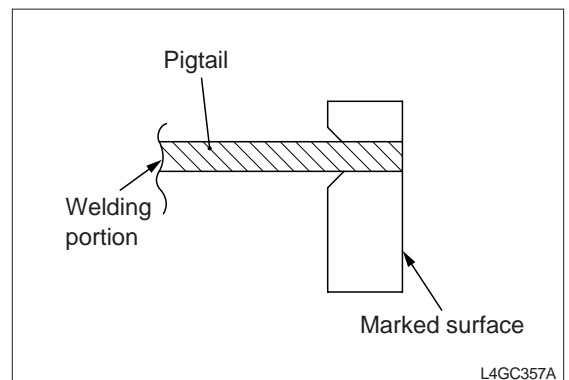

## 10. INSTALLATION OF REAR BRACKET

- 1) Before removing the bushing, measure the bushing press-fit depth.
- 2) Remove the bushing as shown in the illustration.
- 3) Press-fit a new bushing as the depth measured procedure 1).

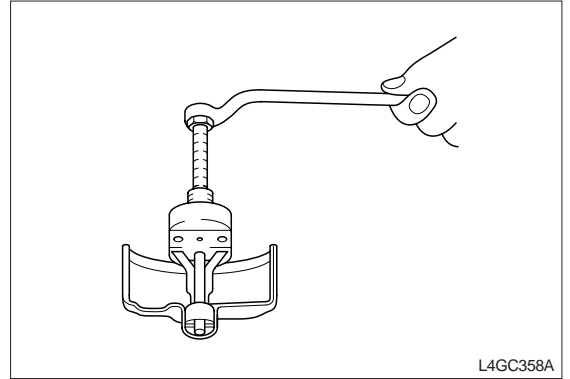
**ASSEMBLY**

1. Install the overrunning clutch to the armature shaft front end.
2. Install the stop ring and snap ring to the armature shaft front end and completely press the stop ring toward the snap ring.
3. When installing the lever to the front bracket, take care of the direction. If the installation direction is in reverse, the pinion will move outward only.

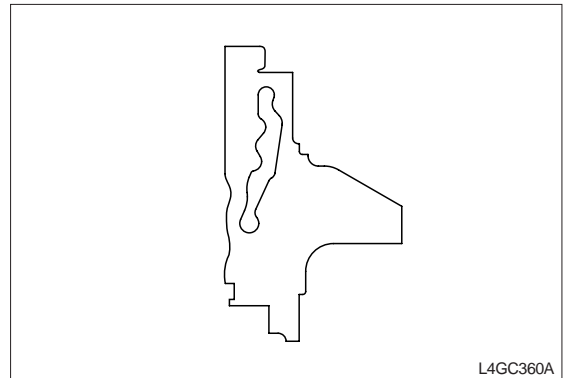
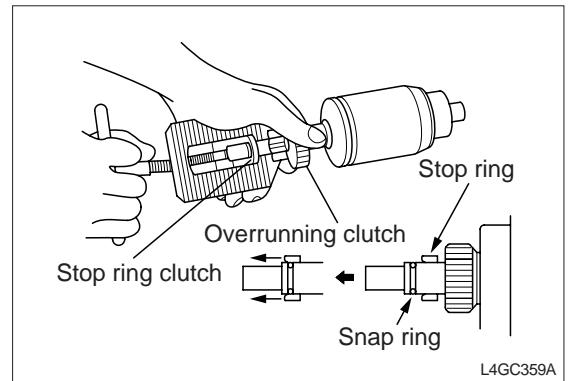

## **CHAPTER 4. FULE SYSTEM AND OTHER**

<b>1. GENERAL .....</b>	<b>4- 1</b>
<b>2. INJECTOR .....</b>	<b>4- 14</b>
<b>4. PVC VALVE .....</b>	<b>4- 16</b>





## GENERAL

## SPECIFICATIONS

Item		Specification	
Fuel filter		Type	High pressure type
Fuel pump (Including fuel filter)		Type	Tank built-in electric type
		Driving	Electric motor
Input sensor	Map sensor	Type	Piezo electric type
		Output voltage	0.8-1.1V(at idle)
			4.5-5V(opened)
	Intake temperature sensor	Type	Thermostat type
		Resistance	2.0Ω - 3.0Ω (at 20°C)
	Water temperature sensor (WTS)	Type	Thermostat type
		Resistance	3.4V (at 20°C)
			2.7V (at 40°C)
	Oxygen sensor	Type	Zirconia sensor (Heater built in type)
		Output voltage	0 - approx. 1V
	Hole sensor (#1 TDC sensor)	Type	Hole effector type
		Output voltage	0~5V
Crankshaft position sensor	Type	Magnetic type	
	Output frequency	IDLE rpm : 600 ~ 800Hz	
		3000 rpm : 2700 ~ 3300Hz	
Output actuator	Injector	Type	Electric-magnetic type
		Number	4
		Coil resistance	14.5 ± 0.35 Ω (20°C)

## SEALANTS

Item	Specified sealant
Water temperature assembly	LOCTITE 962T

## INSPECTION STANDARD

Item		Standard
Ignition timing (2.0DOHC)		BTDC $2^{\circ} \pm 5^{\circ}$
RPM (2.0DOHC)	Neutral, N, P A/CON OFF	$700 \pm 100$ rpm

## TIGHTENING TORQUE

Item	Specified value (kg·m)
Water temperature sensor	1.5 ~ 2.0
Oxygen sensor	5.0 ~ 6.0
Fuel supply pipe mounting bolt	1.0 ~ 1.3
Throttle body mounting bolt	1.5 ~ 2.0
High pressure hose and pipe tightening	2.5 ~ 3.4

## SPECIAL TOOLS

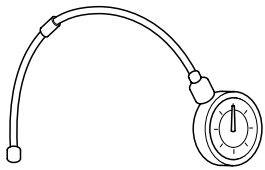
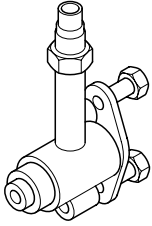
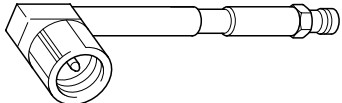
Special tool	Configuration	Use
Fuel pressure gauge and hose (09353-24100)	 L4GC250A	Connection of fuel pressure gauge and fuel supply pipe
Fuel pressure gauge adaptor (09353-38000)	 L4GC251A	
Fuel pressure gauge connector (09353-24000)	 L4GC252A	

---

## TROUBLESHOOTING

When inspecting and repairing the engine, start from the basic unit. If symptoms happen such as (A) engine is not starting (B) irregular idling (C) insufficient acceleration, inspect the basic unit as below.

1. POWER
  - 1) Battery
  - 2) Fusible link
  - 3) Fuse
  - 4) Injector
2. BODY GROUND
3. FUEL SUPPLY
  - 1) Fuel line
  - 2) Fuel filter
  - 3) Fuel pump
4. IGNITION SYSTEM
  - 1) Spark plug
  - 2) High tension cable
  - 3) Ignition coil
  - 4) Crankshaft position sensor
5. EMISSIONS CONTROL SYSTEM
  - 1) PCV system
  - 2) Vacuum leak
6. OTHER
  - 1) Ignition timing check
  - 2) RPM
7. In case of faulty MPI system, it is caused by bad contact of harness sometimes, so inspect the connecting portion.

**INSTRUCTION FOR MPI INSPECTION**

1. When checking the alternator for charging, never remove battery (+) terminal.  
(If peak voltage of alternator is not absorbed by battery, it is possible to burn out ECU power terminal element.)
2. 1. When inspecting circuit, use a digital multi-meter or a LED of 1M $\Omega$  or more.  
(When using normal valve, if heavy load current is sent to ECU, it is possible to burn out driving TR.)
3. When disconnecting ECU harness, necessarily turn Ignition switch OFF.  
(It is possible to damage ECU element by surge.)
4. When removing battery terminal, turn Ignition switch OFF.  
(It is possible to damage ECU element by surge.)
5. When checking A/CON for operation, use a hi-scan and when from the outside (relay driving source), use its harness tool.  
(It is possible to burn out ECU.)
6. When welding vehicle body, necessarily remove ECU first.  
(It is possible to damage ECU element by surge.)
7. When charging battery from outside charger, remove battery (vehicle side) terminal.  
(If supply voltage exceeds rated voltage of EUC, It is possible to burn out ECU.)
8. When charging battery or starting engine with outside charging power, never use it of 16V or more.  
(If supply voltage exceeds rated voltage of EUC, It is possible to burn out ECU.)
9. For circuit test, do not use sensor ground as earth.  
(If heavy load current is run to sensor ground, It is possible to burn out PCB ground circuit.)

**MPI TROUBLESHOOTING PROCEDURE**

**SYMPTOM**

• **ENGINE IS NOT STARTING**

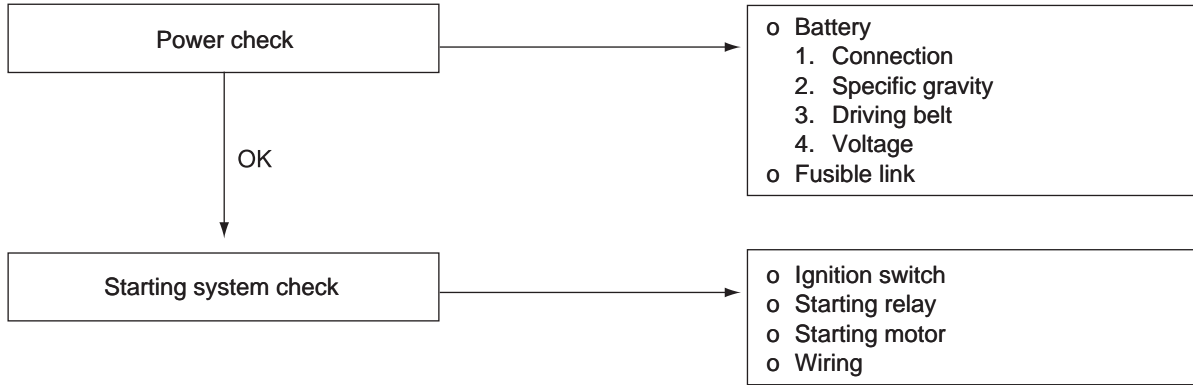

L4GC253A

• **ENGINE IS DIFFICULT TO START(CRANKING OK)**

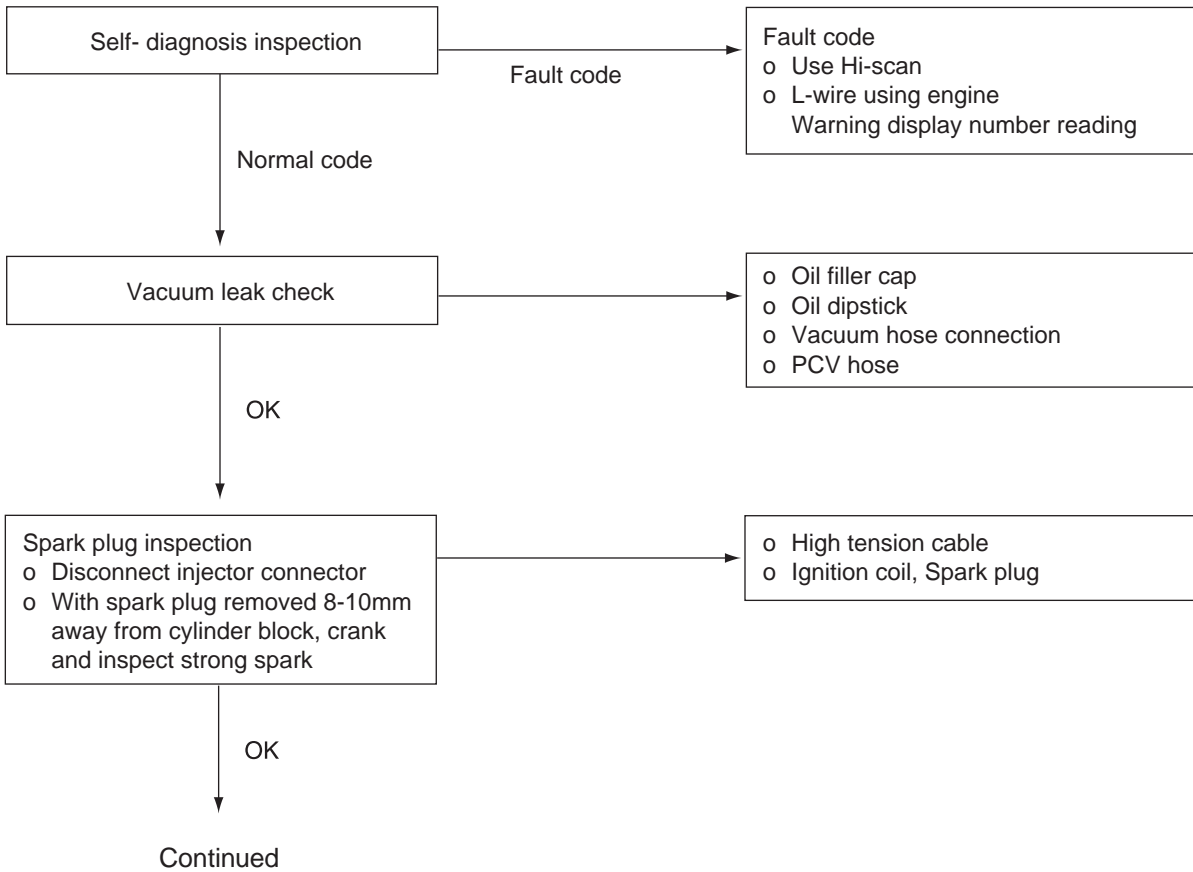

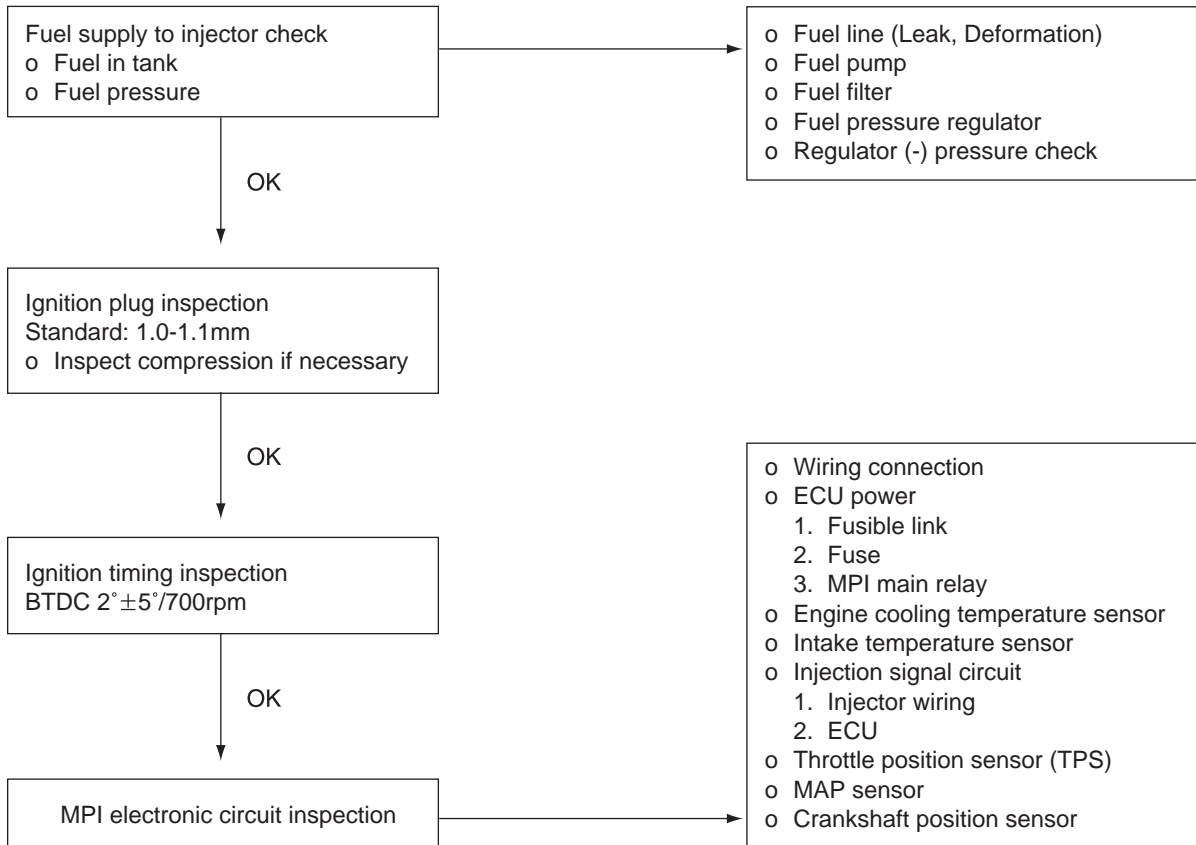

L4GC254A

• **IRREGULAR IDLING OR ENGINE IS SUDDENLY STOPPED**

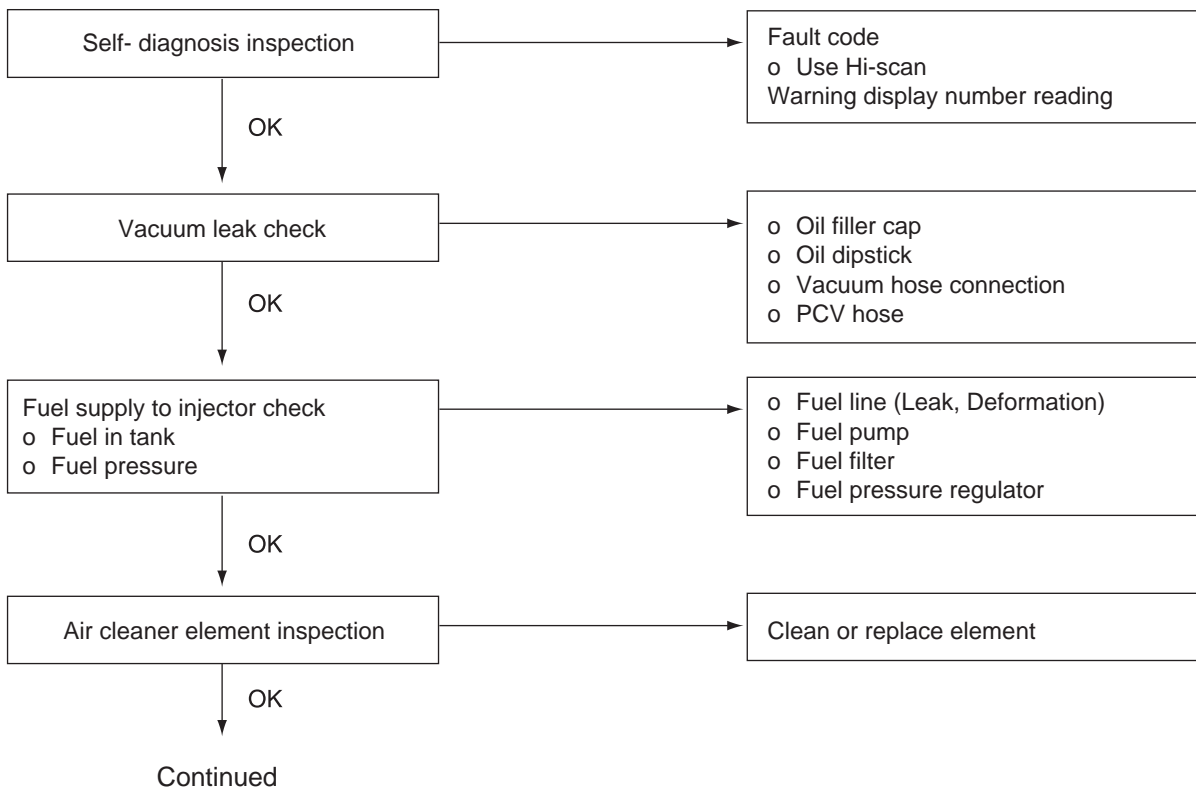

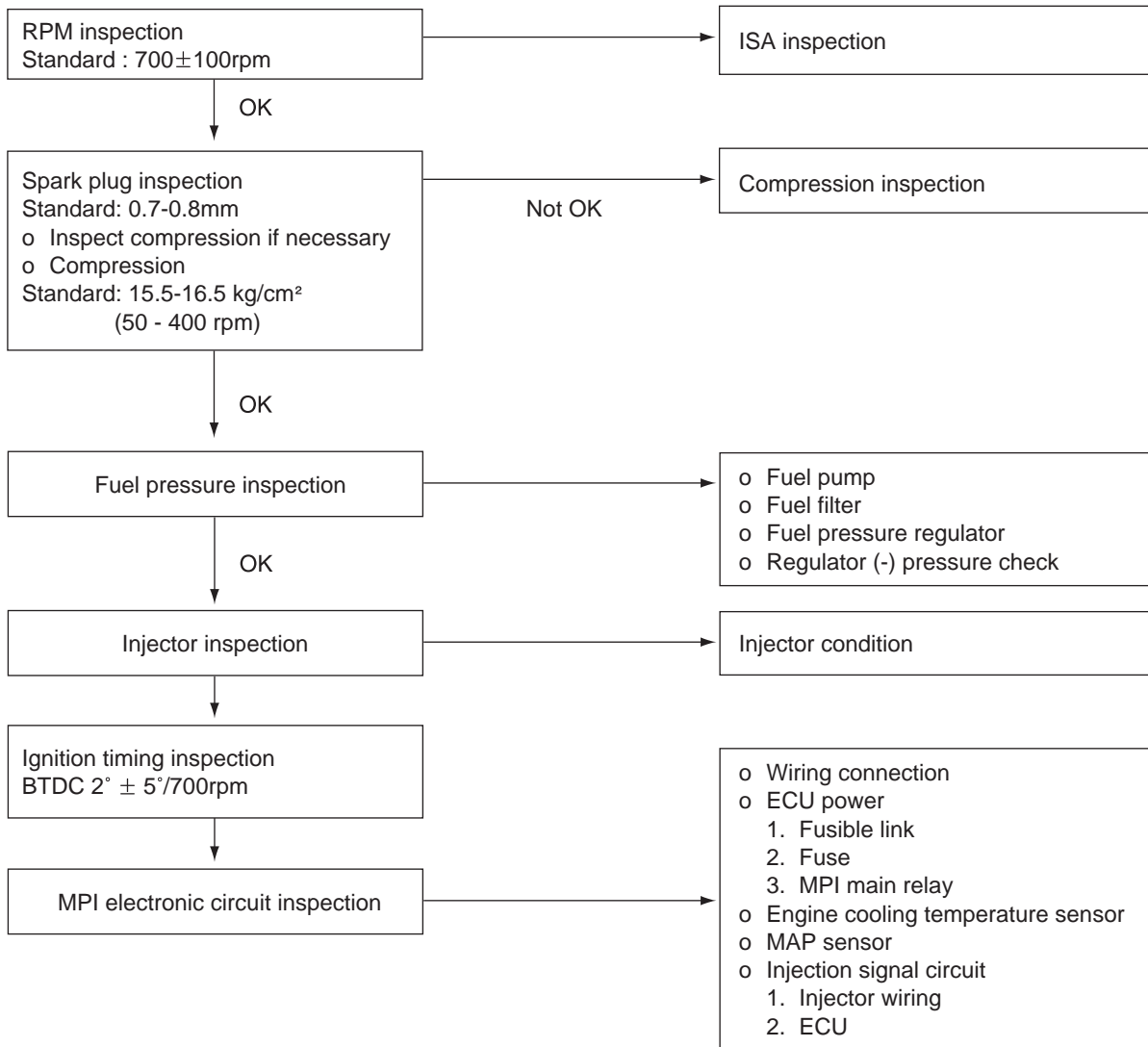

L4GC255A

• ENGINE HESITATION OR INSUFFICIENT ACCELERATION

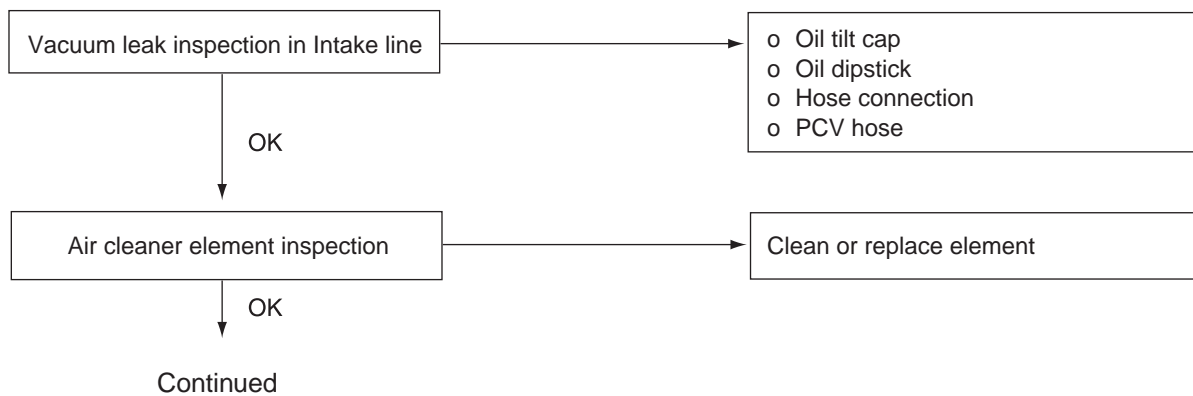

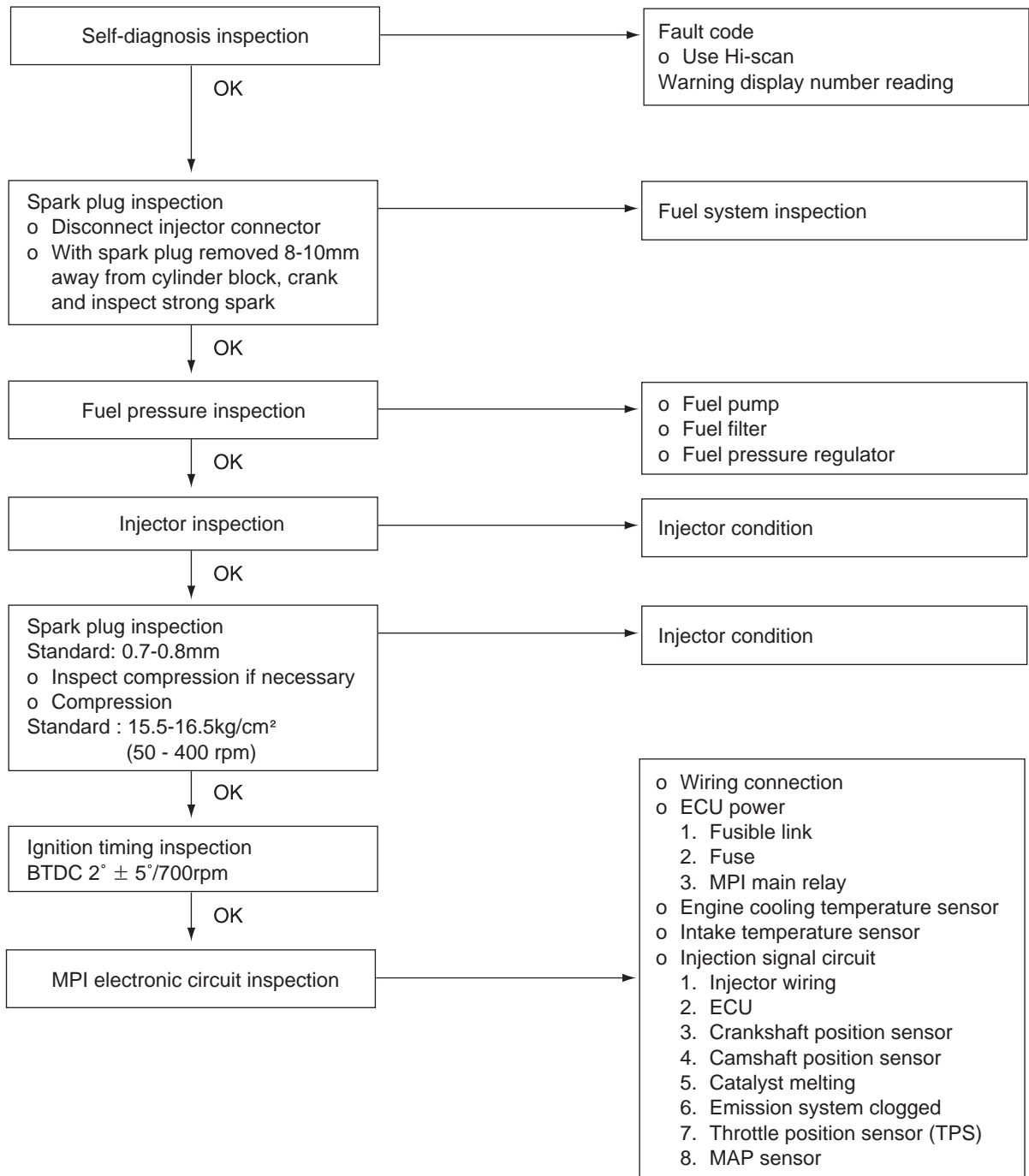



**TROUBLESHOOTING GUIDE**

- The following number represents inspection order.

Main symptom	Item	Starter relay	Starter	Flywheel	Airflow sensor circuit	Fuel pressure regulator	Water temperature sensor	Compression	Piston ring	Ignition timing	Timing belt	Injector	ECU	A/C circuit	Connecting rod bearing	Fuel chamber	Crankshaft bearing
	Sub symptom																
Starting	Not cranking	1	2														
	Starter is rotating but not cranking		1	2													
	Incomplete combustion				1	2	3	4	5	6	7	8	9				
	Increasingly cranking		1											2	3	4	
	Normally difficult to start					4	3	7	8	9		12	13				1
	Difficult to start when cold					4	1					7	8				2
	Difficult to start when hot					4	1					7	8				2
Faulty idling	Incorrect initial idling					1						4	5	3			
	Low RPM				2	1						3	4				
	Irregular idling				9	4		7	8	10	11	12	14				1
	Engine hesitation or deceleration				4	8	5	3		11		12	13				1
Engine stops	After starting, engine stops soon				5	2	6					7	8				1
	After depressing acceleration pedal, engine stops				1	3						5	6				
	After releasing acceleration pedal, engine stops				1								2				
	With A/C ON, engine stops												2	1			
Other	Fuel over-consumption				11		10	6	7	8		9	14	12		1	5

Main symptom	Item	Sub symptom									
	Item	3									
Starting	Not cranking										
	Starter is rotating but not cranking	3									
	Incomplete combustion										
	Increasingly cranking										
	Normally difficult to start		2	5	6	10	11				
	Difficult to start when cold			5	6		3				
	Difficult to start when hot			5	6		3				
Faulty idling	Incorrect initial idling						2				
	Low RPM										
	Irregular idling		3	5	6	13	2	15			
	Engine hesitation or deceleration		2	9	10		6		7		
Engine stops	After starting, engine stops soon			3	4						
	After depressing acceleration pedal, engine stops		2		4						
	After releasing acceleration pedal, engine stops										
	With A/C ON, engine stops										
Other	Fuel over-consumption		4				13	2	3		

Main symptom	Item	Sub symptom											
	Item	1	2	3	4	5	6	7	8	9	10	11	12
Other	Engine is overheated	1	2	3	4	5	6	7	8	9	10	11	12
	Engine is supercooled		1				2						3

## SENSOR CHARACTERISTICS

- OXYGEN SENSOR

Item	Detail
Criterion	<ul style="list-style-type: none"> <li>When oxygen sensor voltage is 1.4V or more</li> <li>With air fuel ratio in closed loop control               <ul style="list-style-type: none"> <li>When oxygen sensor voltage is 0.048 or less for 27 seconds</li> <li>Except idling (more than certain rpm and negative pressure), when cooling temperature is 15°C and in case of 0.348V &lt; oxygen sensor voltage &lt; 0.498V for 27 seconds</li> </ul> </li> </ul>
Faulty sensor management	<ol style="list-style-type: none"> <li>Mixture adaptation control forbidden           <ul style="list-style-type: none"> <li>Fix it as final value</li> </ul> </li> <li>Air fuel ratio in closed loop control [NOTE] By minimum to maximum value difference of oxygen sensor, injection fuel quantity can be different up to 35%</li> </ol>
Troubleshooting	<p>Oxygen sensor/ Related circuit</p> <ol style="list-style-type: none"> <li>Display oxygen sensor related circuit fault</li> <li>Inspect bad connection of connector, faulty wiring</li> <li>Check oxygen sensor for ground           <ul style="list-style-type: none"> <li>Measure voltage between sensor body and engine ground : If measured value is 20mv or less, inspect oxygen sensor parts. If measured value is 20mv or more, clean sensor mounting part.</li> </ul> </li> <li>At sensor output function, inspect oxygen sensor</li> </ol>
Check lamp	If fault code is detected, turned "ON"
HI-SCAN	<ul style="list-style-type: none"> <li>Possible to check fault</li> <li>Possible to check oxygen sensor voltage</li> </ul>

- **CRANKSHAFT POSITION SENSOR (CPS)**

Item	Detail
Criterion	<ul style="list-style-type: none"> <li>• During 4 camshaft signals, if there is no CKP pulse signal, determine it as fault and after this, increase counter per crankshaft signal. (Determine it together with camshaft position sensor every time)</li> </ul>
Faulty sensor management	<ul style="list-style-type: none"> <li>• When fault is detected, there is no corresponding method (Impossible to start engine)</li> </ul> <p>[NOTE] After 4 CKP signals, operate main relay and if signal is stopped after 1.8-3.7 seconds, shut off main relay power. (To determine CKP code in comparison with camshaft position sensor value)</p> <div data-bbox="544 842 956 1072" style="text-align: center;"> <p>L4GC257A</p> </div> <p>During this time, supply power to camshaft position sensor. I.e. to determine if crankshaft position sensor is faulty or not, start motor should be rotating for about 3.7 seconds with IG ON</p> <p>[CAUTION] If camshaft position sensor is faulty, it is impossible to determine CKP fault</p>
Troubleshooting	<p>Oxygen sensor/ Related circuit</p> <ol style="list-style-type: none"> <li>1. Display crank angular sensor related circuit fault</li> <li>2. Inspect sensor to ECU wiring or sensor to connector for fault</li> <li>3. Check sensor surface for foreign material</li> <li>4. Inspect sensor output. <ul style="list-style-type: none"> <li>- At idle: 600-1000Hz</li> <li>- During cranking, measure between sensor no.1 and no.2 terminals : (1.8V-2.5V)</li> </ul> </li> </ol>
Check lamp	No illumination
HI-SCAN	<ul style="list-style-type: none"> <li>• Possible to check oxygen sensor voltage</li> </ul>

• CAMSHAFT POSITION SENSOR (NO.1 TDC SENSOR), VEHICLE SPEED SENSOR

Item	Detail	Vehicle speed sensor
Criterion	<ul style="list-style-type: none"> <li>During 4 camshaft signals, there is no signal changed at camshaft position sensor</li> </ul>	<ul style="list-style-type: none"> <li>When 400rpm or more, (-) pressure of 574mb or more, and negative pressure limit is less than 121mb, there is no sensor signal over 3 seconds</li> </ul>
Faulty sensor management	<ul style="list-style-type: none"> <li>Injection successive injection control</li> </ul>	<ul style="list-style-type: none"> <li>Determine all as ON DRIVING [NOTE] Vehicle signal is used for ignition timing control. Assume proper gear by calculating rpm, vehicle speed, and gear ratio backward. Control ignition timing to prevent impact when repressing throttle again after releasing.</li> </ul>
Troubleshooting	<p>No.1 cylinder TDC sensor/related circuit</p> <ol style="list-style-type: none"> <li>Display fault of cylinder TDC detecting sensor (CMP sensor) and related circuit</li> <li>Check connector for bad connection and wiring for fault</li> <li>Inspect sensor contact surface for cleanness</li> <li>Inspect sensor output                             <ul style="list-style-type: none"> <li>At idle: 5-9Hz(0-5V)</li> <li>3000rpm : 20-30Hz(0-5V)</li> </ul> </li> </ol>	<p>Vehicle speed sensor/Related circuit</p> <ol style="list-style-type: none"> <li>Display fault of vehicle speed sensor related circuit</li> <li>Inspect bad connection of connector, faulty wiring</li> <li>Inspect speedometer cable</li> <li>Inspect vehicle speed sensor                             <ul style="list-style-type: none"> <li>With vehicle stopped : 0Hz</li> <li>While driving at about 300km/h : 20-30Hz</li> </ul> </li> </ol>
Check lamp	OFF at all times	OFF at all times
HI-SCAN	<ul style="list-style-type: none"> <li>Possible to check fault</li> </ul>	<ul style="list-style-type: none"> <li>Possible to check fault</li> </ul>

## INJECTOR

### INSPECTION

#### FUNCTION AND OPERATING PRINCIPLE

Injector as a electronic controlled fuel injection unit, is solenoid valve which supplies exactly calculated fuel as a spray to engine to best combustion under the condition of various engine load and speed.

For fuel consumption reduction, engine performance enhancement and emission reduction, ECM controls fuel injection to satisfy air fuel ratio required by system by reflecting induced airflow and air fuel ratio among emission and adjusting injector operating time. To enhance these control characteristics, quick response of injector is required, and spray feature of injector is important for perfect combustion.

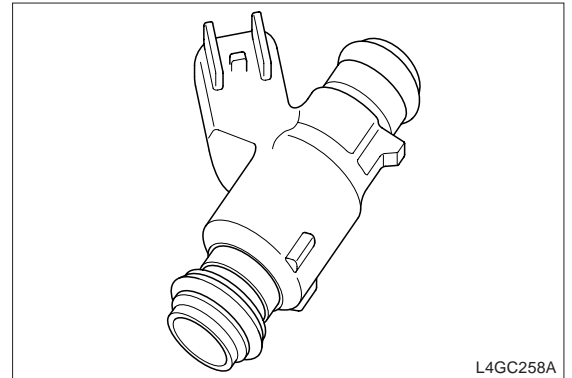

L4GC258A

Item	Specified value
Coil resistance ( $\Omega$ )	13.8 ~ 15.2 (20°C)

CIRCUIT DIAGRAM

[CIRCUIT DIAGRAM]

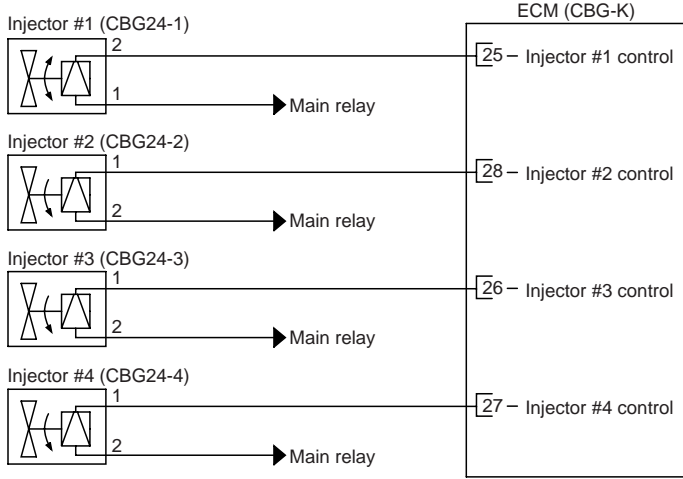

[CONNECTING INFORMATION]

INJECTOR #1 (CBG24-1)

Terminal	Connecting area	Function
1	Main relay	Power (B+)
2	ECM CBG-K (25)	Injector #1 control

INJECTOR #2 (CBG24-2)

Terminal	Connecting area	Function
1	ECM CBG-K (28)	Injector #2 control
2	Main relay	Power (B+)

INJECTOR #3 (CBG24-3)

Terminal	Connecting area	Function
1	ECM CBG-K (26)	Injector #3 control
2	Main relay	Power (B+)

INJECTOR #4 (CBG24-4)

Terminal	Connecting area	Function
1	ECM CBG-K (27)	Injector #4 control
2	Main relay	Power (B+)

[HARNESS CONNECTOR]

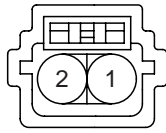

CBG24-1,2,3,4  
Injector #1,2,3,4

L4GC259A

PARTS INSPECTION

1. Turn the ignition switch OFF.
2. Disconnect the injector connector.
3. Measure resistance between injector terminal #1 and #2.
4. Check that the measured resistance is different from specification (Refer to SPECIFICATIONS)

Specified value	See "SPECIFICATIONS"
-----------------	----------------------

# PCV VALVE

## OUTLINE AND OPERATING PRINCIPLE

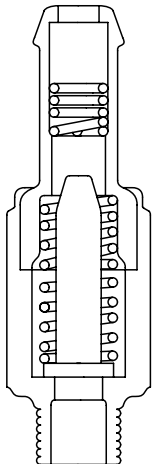
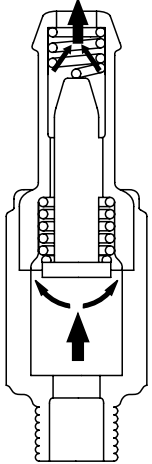
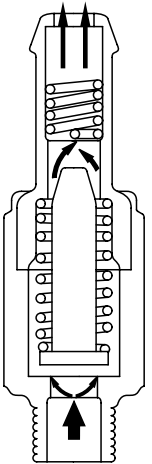
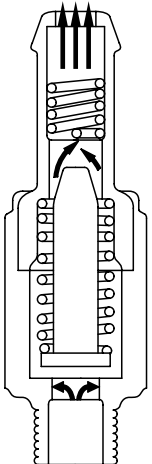
<p>Intake Manifold Side (No Vacuum)</p>  <p>Locker Cover Side</p> <p style="text-align: right;">L4GC260A</p>		<p>Intake Manifold Side (High Vacuum)</p>  <p>Locker Cover Side</p> <p style="text-align: right;">L4GC261A</p>	
Engine condition	No operating	Engine condition	At idle or deceleration
PCV valve	No operating	PCV valve	Full operating
Vacuum path	Clogged	Vacuum path	Small
<p>Intake Manifold Side (Sufficient Vacuum)</p>  <p>Locker Cover Side</p> <p style="text-align: right;">L4GC262A</p>		<p>Intake Manifold Side (Low Vacuum)</p>  <p>Locker Cover Side</p> <p style="text-align: right;">L4GC263A</p>	
Engine condition	Proper operating	Engine condition	High speed and overload
PCV valve	Proper operating	PCV valve	Light operating
Vacuum path	Big	Vacuum path	Very big



## SERVIE PROCEDURE

### REMOVAL

1. After disconnecting the vacuum hose(A), remove the PCV valve(B).

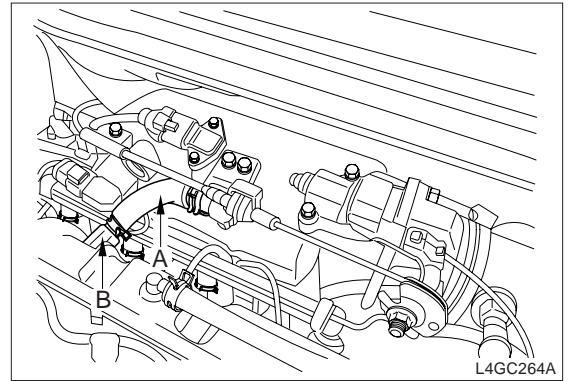

### INSTALLATION

Install the PCV valve and connect the vacuum hose.

<b>Tightening torque</b>	0.8 ~ 1.2kgf·m
--------------------------	----------------

### INSPECTION

1. Remove the PCV valve.
2. Check the plunger for movement by inserting a thin stick (A) toward the valve (B) nut.
3. If the plunger is not moved, it means that PCV valve is clogging, so, clean or replace PCV valve.

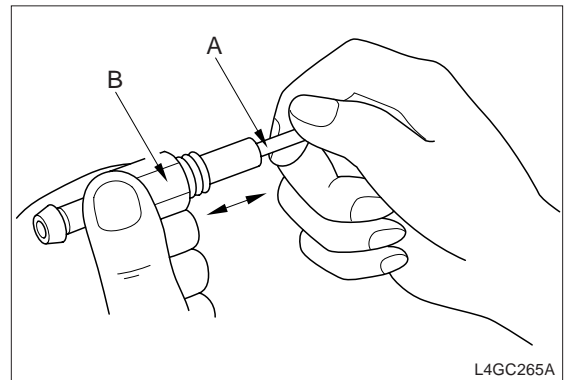

### TROUBLESHOOTING

1. Disconnect the vacuum hose from the PCV valve. Disconnect the PCV valve from the locker cover and reconnect the vacuum hose.
2. With the engine at idle, Check the intake manifold for vacuum when clogging the opened end of PCV valve.

**NOTE**

*The plunger in PCV valve will move back and forth.*

3. If vacuum is not detected, clean or replace PCV valve and vacuum hose.

