

SECTION 5 MECHATRONICS SYSTEM

| | |
|---|-------|
| Group 1 Outline | 5-1 |
| Group 2 Mode Selection System | 5-3 |
| Group 3 Automatic Deceleration System | 5-6 |
| Group 4 Power Boost System | 5-7 |
| Group 5 Travel Speed Control System | 5-8 |
| Group 6 Automatic Warming Up System | 5-9 |
| Group 7 Engine Overheat Prevention System | 5-10 |
| Group 8 Variable Power Control System | 5-11 |
| Group 9 Attachment Flow Control System | 5-12 |
| Group 10 Anti-Restart System | 5-13 |
| Group 11 Self-Diagnostic System | 5-14 |
| Group 12 Engine Control System | 5-74 |
| Group 13 EPPR Valve | 5-75 |
| Group 14 Monitoring System | 5-80 |
| Group 15 Fuel Warmer System | 5-116 |

SECTION 5 MECHATRONICS SYSTEM

GROUP 1 OUTLINE

The ADVANCED CAPO (Computer Aided Power Optimization) system controls engine and pump mutual power at an optimum and less fuel consuming state for the selected work by mode selection, auto-deceleration, power boost function, etc. It monitors machine conditions, for instance, engine speed, coolant temperature, hydraulic oil temperature, and hydraulic oil pressure, etc.

It consists of a MCU, a cluster, an ECM, EPPR valves, and other components. The MCU and the cluster protect themselves from over-current and high voltage input, and diagnose malfunctions caused by short or open circuit in electric system, and display error codes on the cluster.

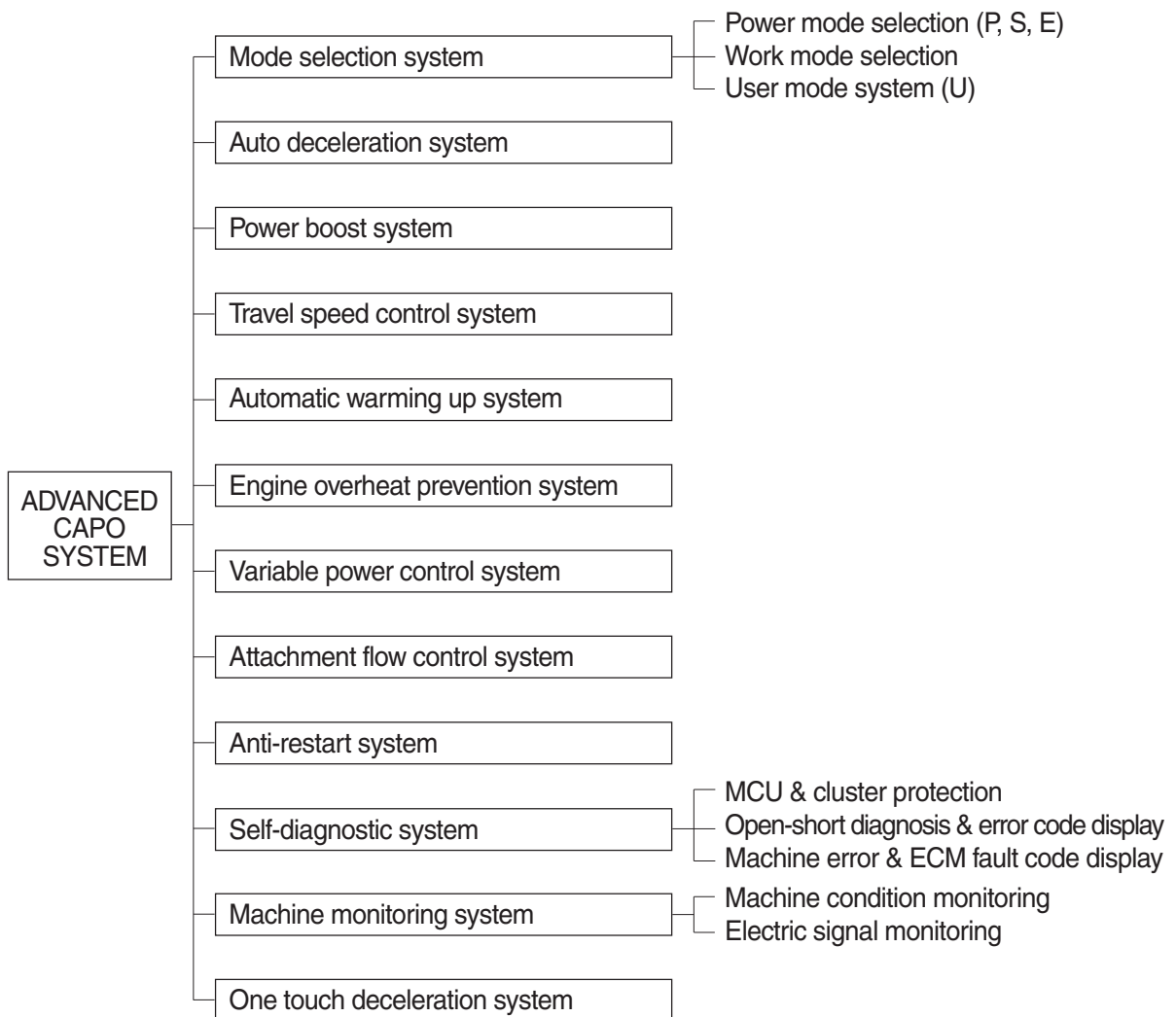

SYSTEM DIAGRAM

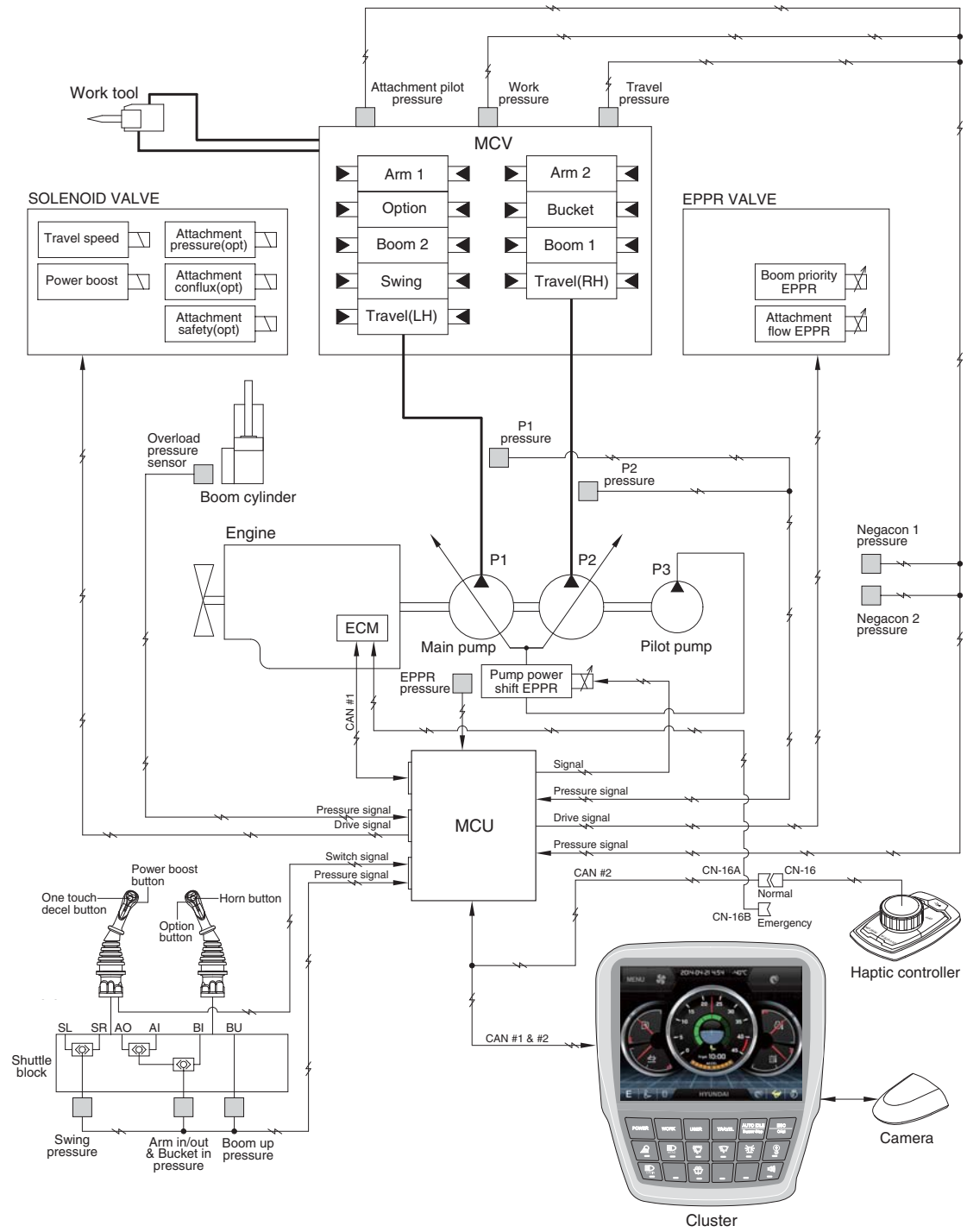

900L5MS01

GROUP 2 MODE SELECTION SYSTEM

1. POWER MODE SELECTION SYSTEM

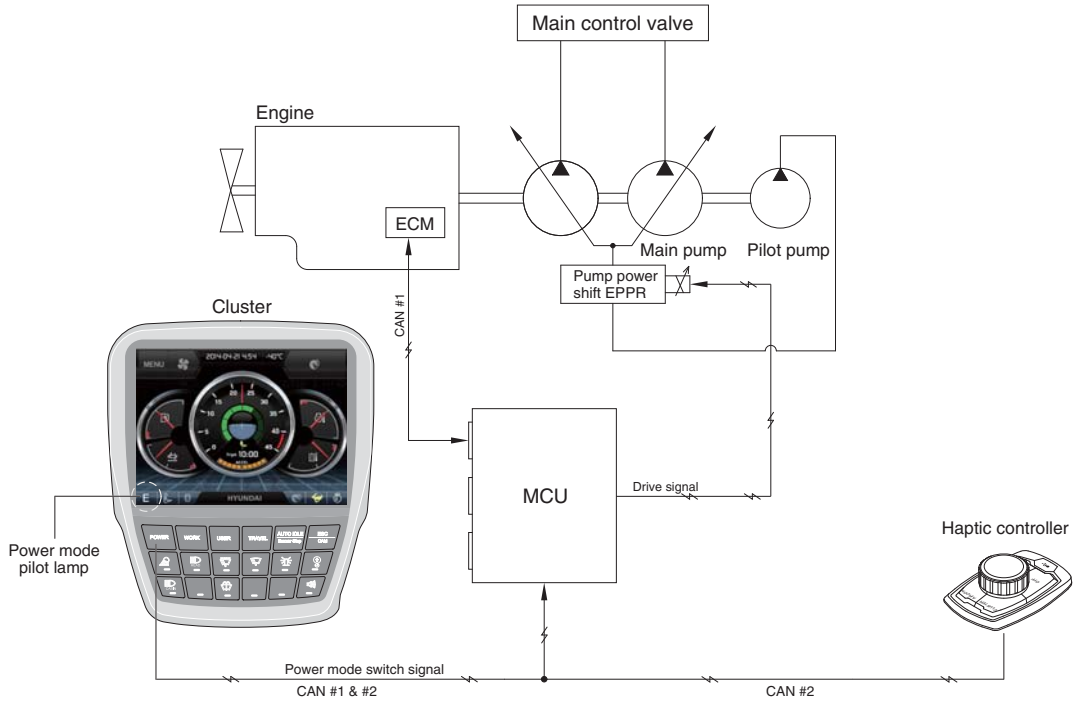

900L5MS14

Mode selection system (micro computer based electro-hydraulic pump and engine mutual control system) optimizes the engine and pump performance.

The combination of 3 power modes (P, S, E) and acceleration mode (10 set) of haptic controller makes it possible to use the engine and pump power more effectively corresponding to the work conditions from a heavy and great power requesting work to a light and precise work.

| Power mode | Application | Engine rpm | | | | Power shift by EPPR valve | | | |
|-----------------|---------------------------|------------|-----------|------------|-----------|---------------------------|---------------------------------|--------------|---------------------------------|
| | | Standard | | Option | | Standard | | Option | |
| | | Unload | Load | Unload | Load | Current (mA) | Pressure (kgf/cm ²) | Current (mA) | Pressure (kgf/cm ²) |
| P | Heavy duty power | 1750 ± 50 | 1850 ± 50 | 1850 ± 50 | 1850 ± 50 | 280 ± 30 | 8 (~3) | 230 ± 30 | 0 (0) |
| S | Standard power | 1650 ± 50 | 1750 ± 50 | 1800 ± 50 | 1800 ± 50 | 305 ± 30 | 10 (~5) ± 3 | 260 ± 30 | 0 (0) |
| E | Economy operation | 1550 ± 50 | 1650 ± 50 | 1600 ± 50 | 1750 ± 50 | 340 ± 30 | 13 (~8) ± 3 | 340 ± 30 | 5 ± 3 (0) |
| AUTO DECEL | Engine deceleration | 1000 ± 100 | - | 1000 ± 100 | - | 700 ± 30 | 38 ± 3 | 700 ± 30 | 38 ± 3 |
| One touch decel | Engine quick deceleration | 850 ± 100 | - | 850 ± 100 | - | 700 ± 30 | 38 ± 3 | 700 ± 30 | 38 ± 3 |
| KEY START | Key switch start position | 850 ± 100 | - | 850 ± 100 | - | 700 ± 30 | 38 ± 3 | 700 ± 30 | 38 ± 3 |

※ Power shift (Standard/Option) can be changed by "Service menu" in "Management" on the cluster.

※ (~*) : Load

2. WORK MODE SELECTION SYSTEM

Work mode consists of the general operation (bucket) and the optional attachment (breaker, crusher).

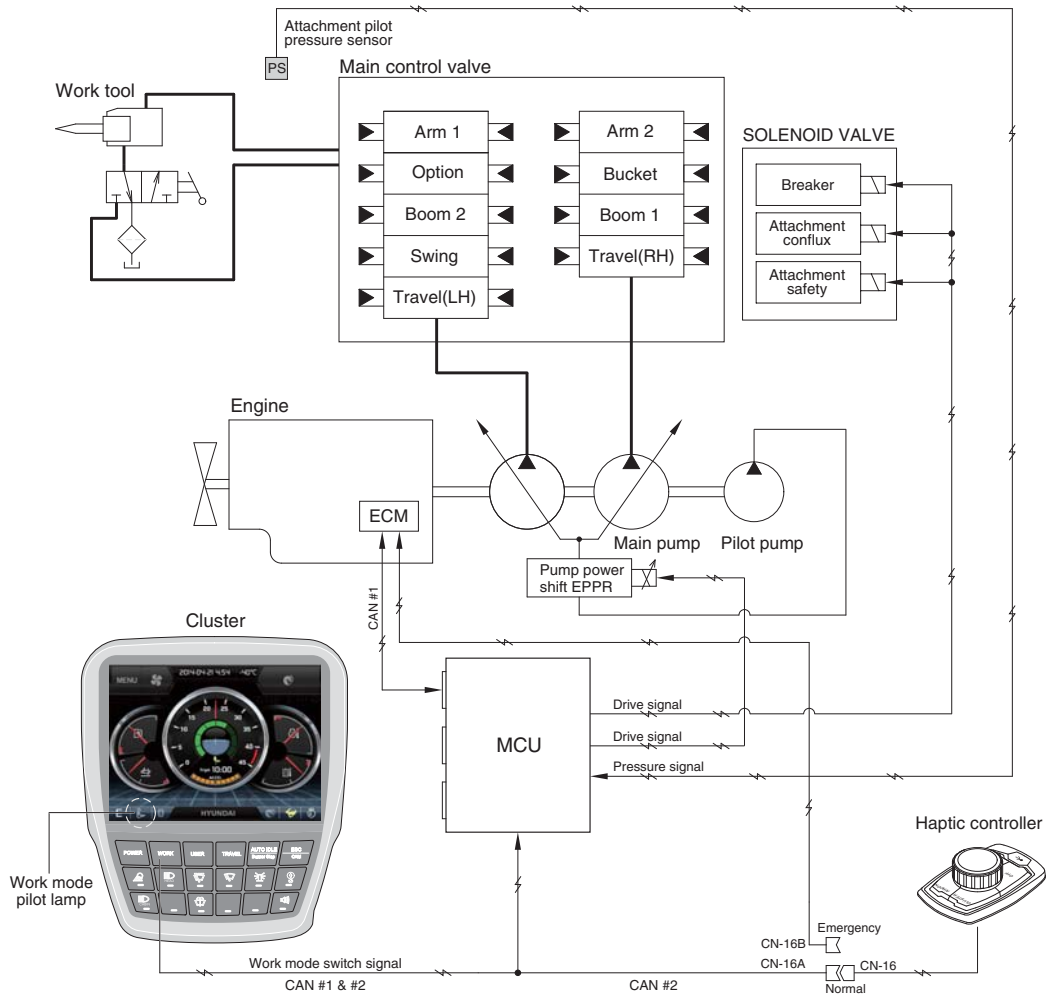

900L5MS02

1) GENERAL WORK MODE (bucket)

This mode is used to general digging work.

2) ATT WORK MODE (breaker, crusher)

It controls the pump flow and system pressure according to the operation of breaker or crusher.

| Description | General mode | Work tool | |
|------------------------------|--------------|------------|------------|
| | Bucket | Breaker | Crusher |
| Attachment safety solenoid | OFF | - | ON |
| Attachment conflux solenoid | OFF | ON/OFF | ON/OFF |
| Attachment flow EPPR current | 100 mA | 100~700 mA | 100~700 mA |
| Breaker solenoid* | OFF | ON | - |

★ When breaker operating button is pushed.

3. USER MODE SELECTION SYSTEM

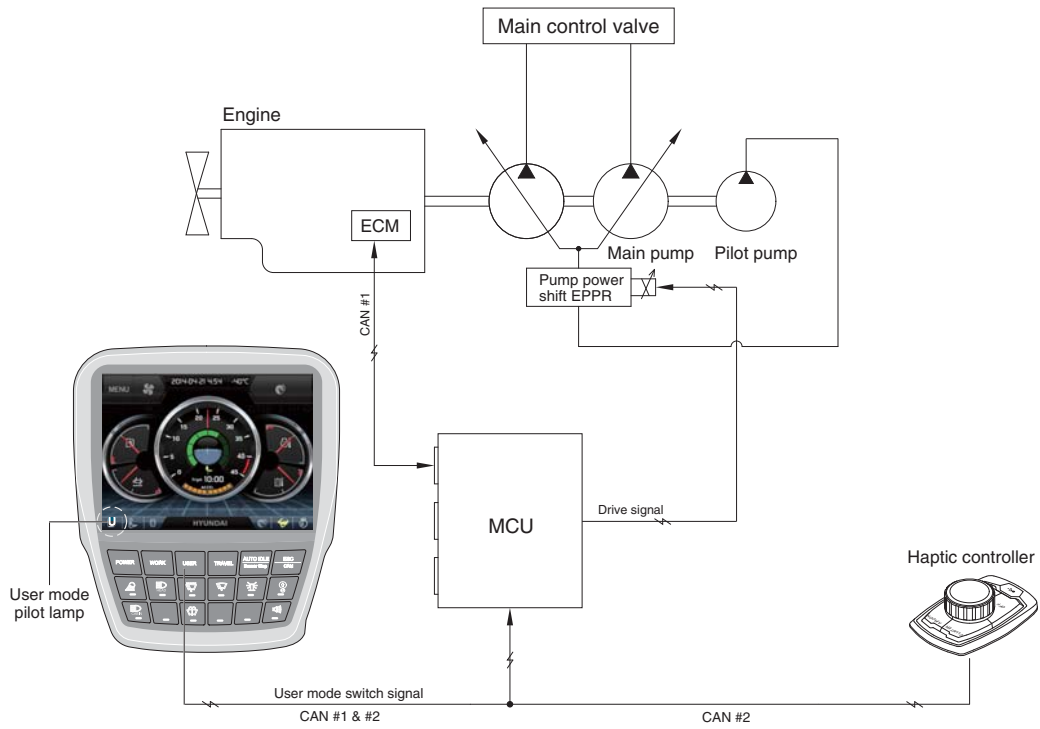

900L5MS15

1) High idle rpm, auto idle rpm and EPPR pressure can be adjusted and memorized in the U-mode.

2) LCD segment vs parameter setting

| Step (■) | Engine speed (rpm) | Idle speed (rpm) | Power shift (bar) |
|---------------|-----------------------|---------------------|----------------------|
| 1 | 1450 | 800 | 0 |
| 2 | 1500 | 850 | 3 |
| 3 | 1600 | 900 | 6 |
| 4 | 1700 | 950 | 9 |
| 5 | 1750 | 1000 (auto decel) | 12 |
| 6 | 1800 | 1050 | 16 |
| 7 | 1850 | 1100 | 20 |
| 8 | 1900 | 1150 | 26 |
| 9 | 1950 | 1180 | 32 |
| 10 | 2000 | 1200 | 38 |

GROUP 3 AUTOMATIC DECELERATION SYSTEM

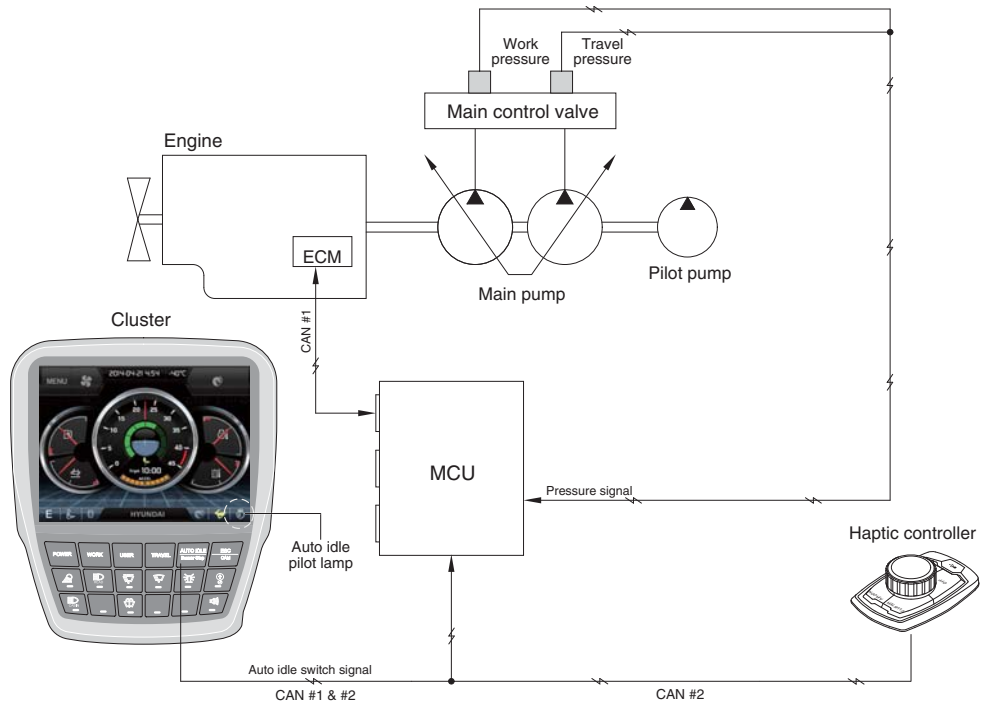

900L5MS16

1. WHEN AUTO IDLE PILOT LAMP ON

When all of the work equipment control levers including swing and travel levers are at neutral for 4 seconds, MCU sends throttle command to ECM to reduce the engine speed to 1000 rpm. If the control levers are at neutral for 1 minute, MCU reduces the engine speed to 850 rpm. As the result of reducing the engine speed, fuel consumption and noise are effectively cut down during non-operation of the control levers.

When the Auto idle pilot lamp is turned off by pressing the switch or any control lever is operated, the reduced engine speed rises upto the speed before deceleration in a second.

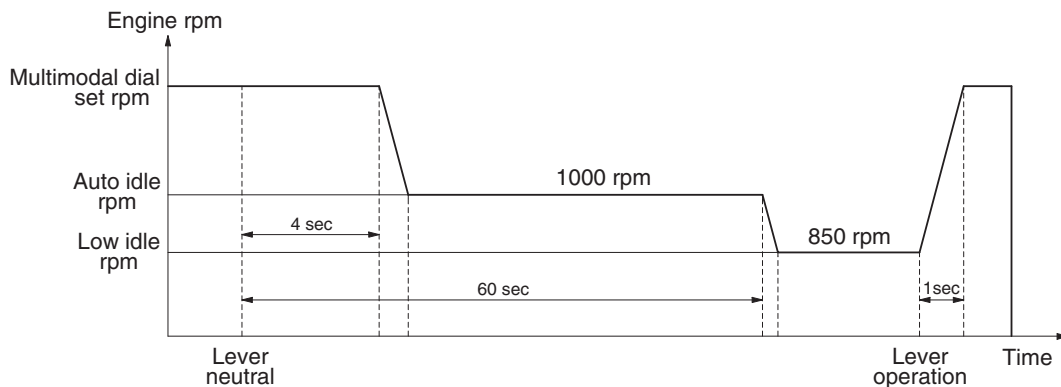

900L5MS03

2. WHEN AUTO IDLE PILOT LAMP OFF

The engine speed can be set as desired using the multimodal dial, and even if the control levers are neutral, the engine speed is not reduced.

※ Auto idle function can be activated when multimodal dial position is over 4.

GROUP 4 POWER BOOST SYSTEM

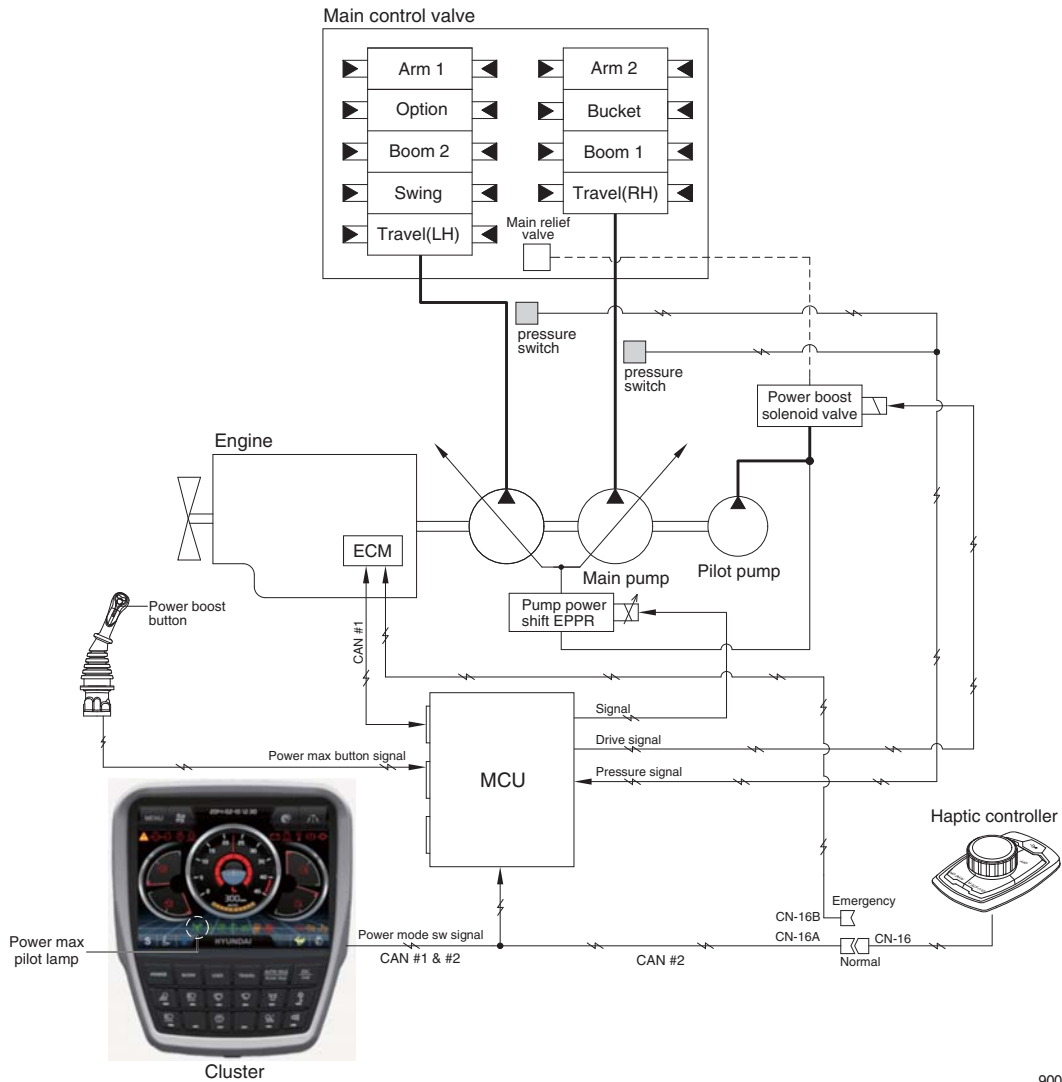

900L5MS04

- When the power boost switch on the left control lever knob is pushed ON, the power mode is set P mode and maximum digging power is increased by 10 %.
- When the power boost function is activated, the power boost solenoid valve pilot pressure raises the set pressure of the main relief valve to increase the digging power.

| Description | Condition | Function |
|-------------|---|---|
| Activated | Power boost switch : ON Multimodal dial : over 8 | - Power mode : P - Multimodal dial power : 9 - Power boost solenoid : ON - Power boost pilot lmap : ON - Operating time : max 8 seconds |
| Canceled | Power boost switch : OFF | - Pre-set power mode - Power boost solenoid : OFF - Power boost pilot lamp : OFF |

- ※ When the auto power boost is set to Enable and power mode is set to P mode on the cluster, the digging power is automatically increased as working conditions by the MCU. It is operated max 8 seconds.

GROUP 5 TRAVEL SPEED CONTROL SYSTEM

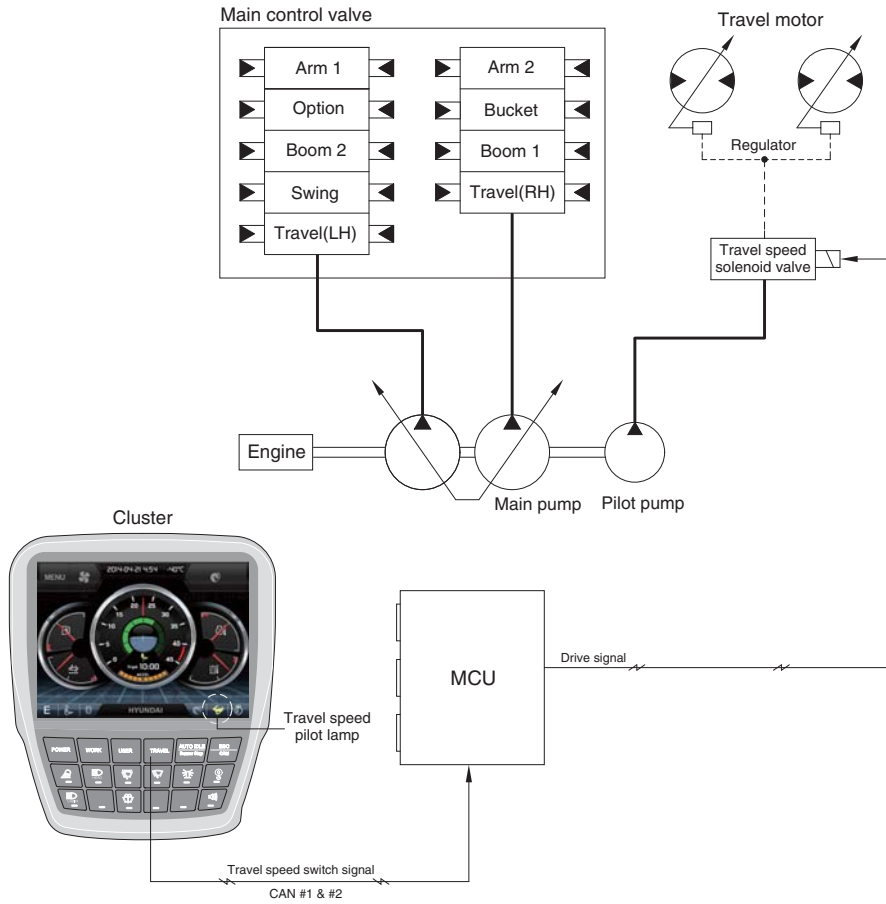

900L5MS05

Travel speed can be switched manually by pressing the travel speed switch on the cluster.

| Speed | Travel speed solenoid valve | Lamp on cluster | Operation |
|-------|-----------------------------|-----------------|--|
| Low | OFF | Turtle | Low speed, high driving torque in the travel motor |
| High | ON | Rabbit | High speed, low driving torque in the travel motor |

※ Default : Turtle (Low)

GROUP 6 AUTOMATIC WARMING UP SYSTEM

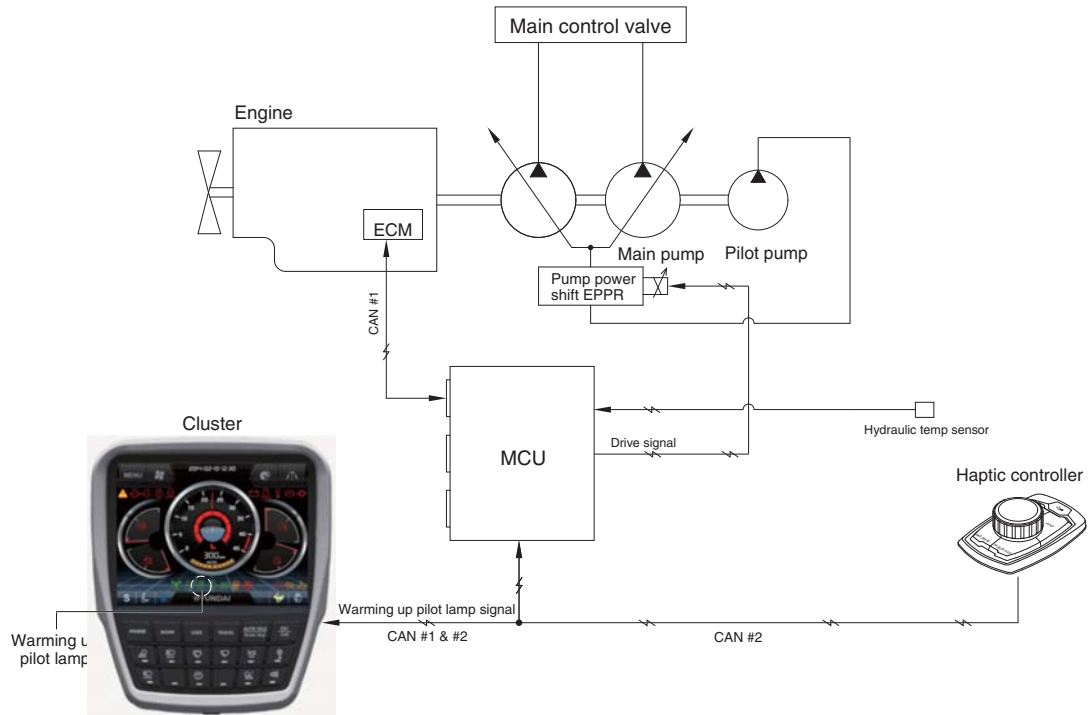

900L5MS17

1. The MCU receives the engine coolant temperature from the ECM, and if the coolant temperature is below 30°C, it increases the engine speed from key start rpm to 1000 rpm. At this time the mode does not change. If the coolant temperature sensor has fault, the hydraulic oil temperature signal is substituted.
2. In case of the coolant temperature increases up to 30°C, the engine speed is decreased to key start speed. And if an operator changes power mode set during the warming up function, the MCU cancels the automatic warming up function.

3. LOGIC TABLE

| Description | Condition | Function |
|-------------|---|---|
| Actuated | - Coolant temperature : below 30°C (after engine run) | - Power mode : Default (E mode) - Warming up time : 10 minutes (max) - Warming up pilot lamp : ON |
| Canceled | - Coolant temperature : Above 30°C - Warming up time : Above 10 minutes - Changed power mode set by operator - RCV lever or pedal operating - Auto idle cancel ※ If any of the above conditions is applicable, the automatic warming up function is canceled | - Power mode : set mode - Warming up pilot lamp : OFF |

GROUP 7 ENGINE OVERHEAT PREVENTION SYSTEM

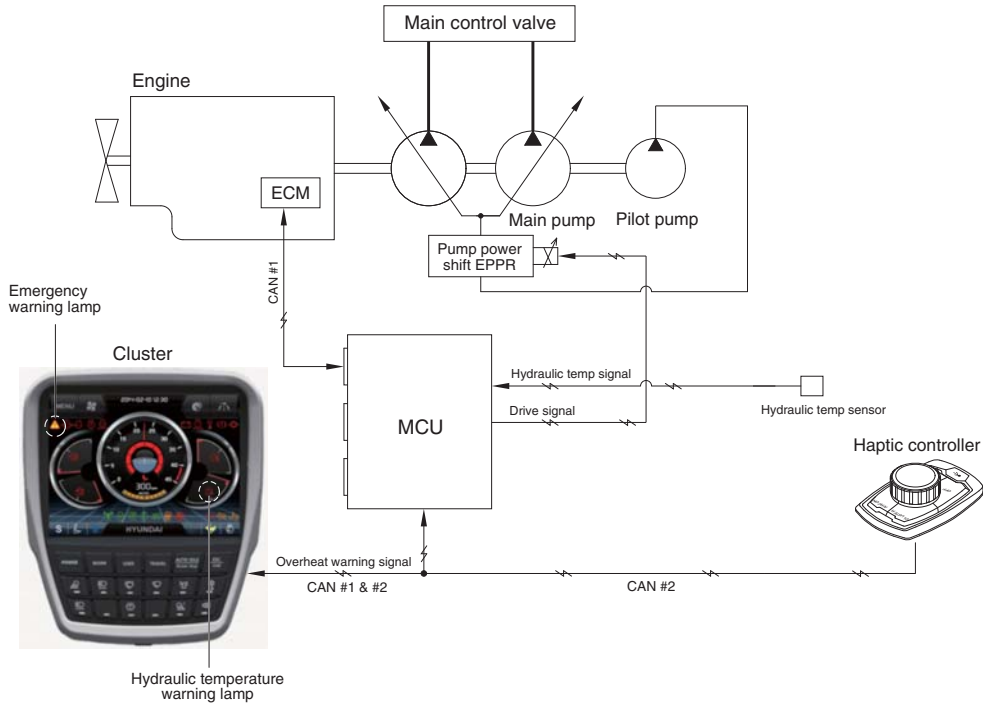

900L5MS18

1. If the engine coolant temperature or the hydraulic oil temperature is overheated over 103°C or 100°C, the warning lamp is ON and the pump input torque or the engine speed is reduced as below logic table.

2. LOGIC TABLE

| Description | | Condition | Function |
|---------------------|-----------|--|---|
| First step warning | Activated | - Coolant temperature : Above 103°C - Hydraulic oil temperature : Above 100°C | - Warning lamp : ON , buzzer : OFF - Pump input torque is reduced. |
| | Canceled | - Coolant temperature : Less than 100°C - Hydraulic oil temperature : Less than 95°C | - Warning lamp & buzzer : ON - Pump input torque is reduced. |
| Second step warning | Activated | - Coolant temperature : Above 107°C - Hydraulic oil temperature : Above 105°C | - Emergency warning lamp pops up on the center of LCD and the buzzer sounds. - Engine speed is reduced after 10 seconds. |
| | Canceled | - Coolant temperature : Less than 103°C - Hydraulic oil temperature : Less than 100°C | - Return to pre-set the engine speed. - Hold pump absorption torque on the first step warning. |

GROUP 8 VARIABLE POWER CONTROL SYSTEM

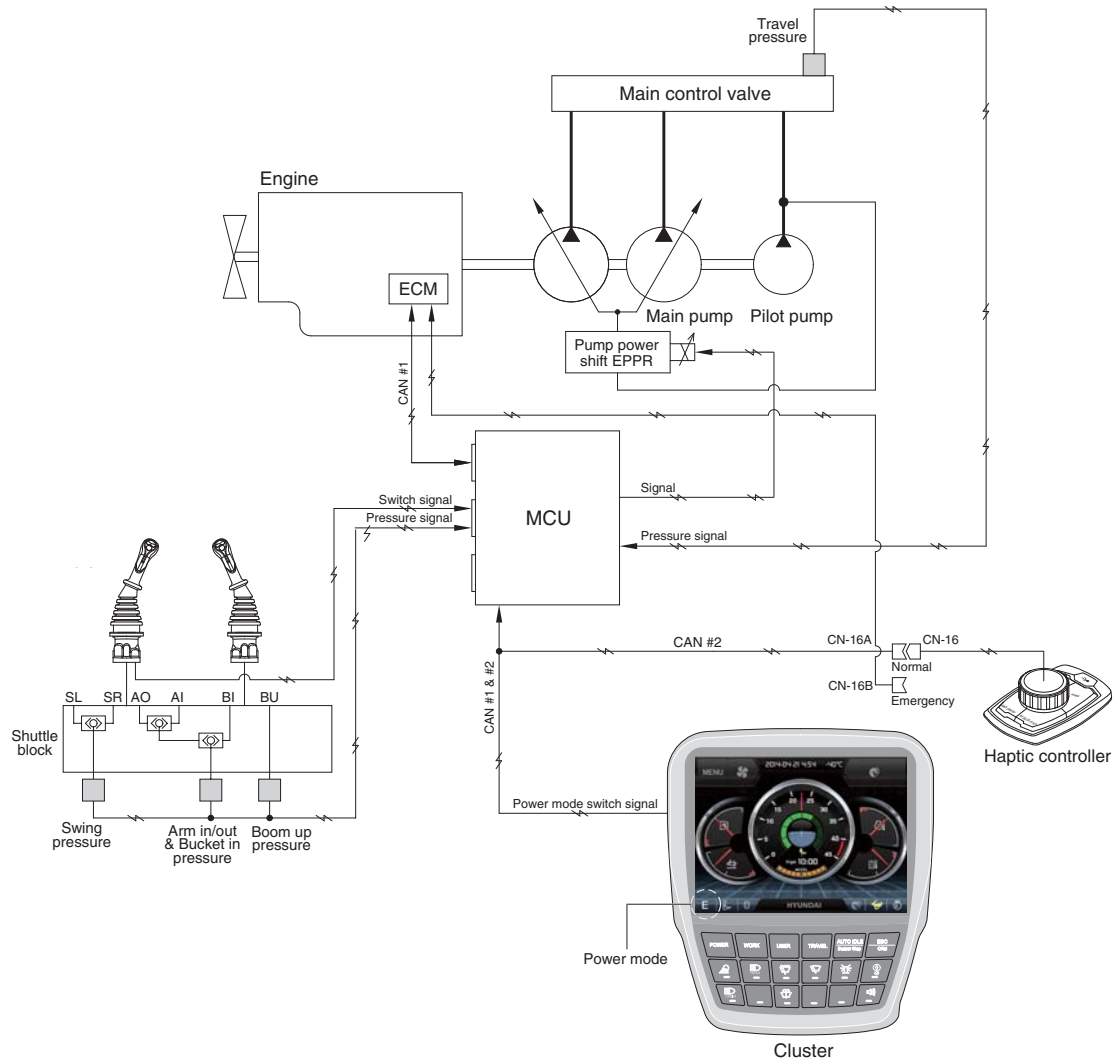

900L5MS06

- The variable power control system controls the engine and pump mutual power according to RCV lever stroke and pump load. It makes fuel saving and smooth control at precise work.

| Description | Working condition |
|-----------------|-------------------|
| Power mode | P, S, E |
| Work mode | General (bucket) |
| Pressure sensor | Normal |

※ The variable power control function can be activated when the power mode is set to all power mode.

GROUP 9 ATTACHMENT FLOW CONTROL SYSTEM

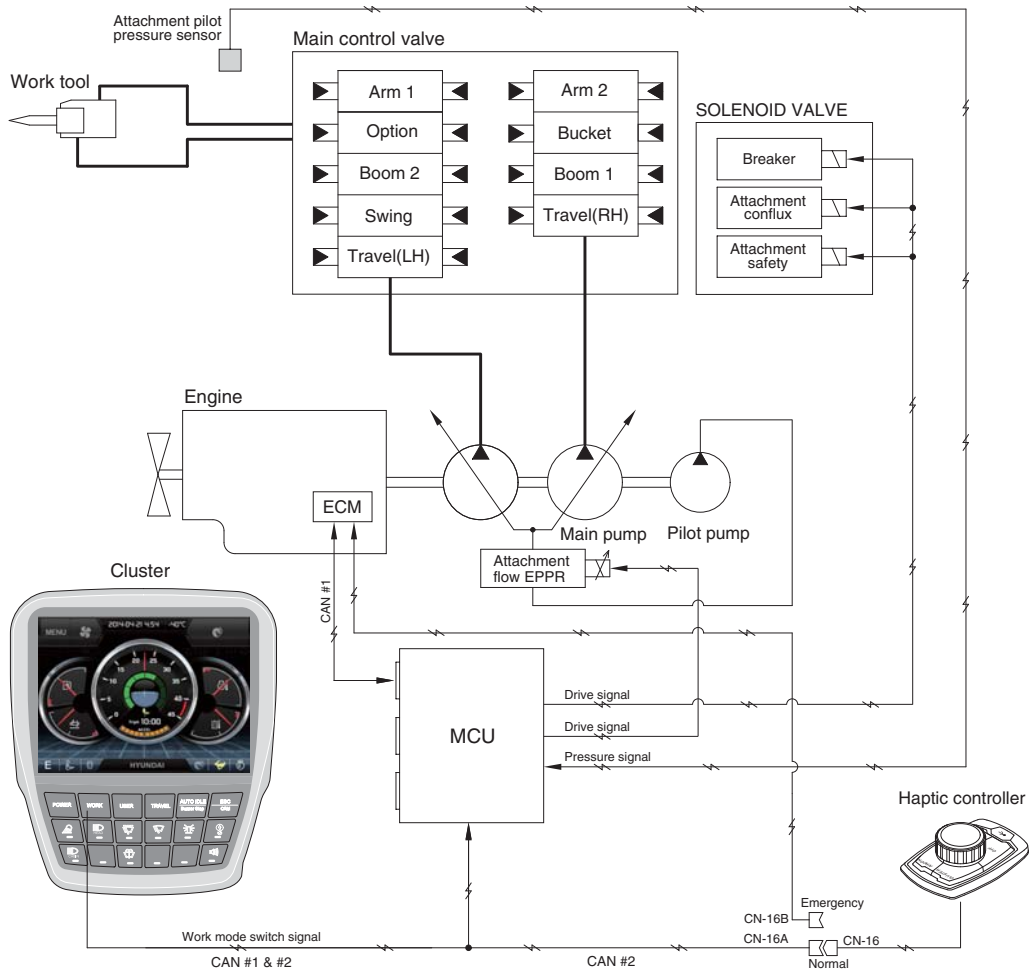

900L5MS07

- The system is used to control the pump delivery flow according to set of the work tool on the cluster by the attachment flow EPPR valve.

| Description | Work tool | |
|-------------------------|---------------|---------------|
| | Breaker | Crusher |
| Flow level | 100 ~ 420 lpm | 100 ~ 760 lpm |
| Attach safety solenoid | - | ON |
| Attach conflux solenoid | ON/OFF | ON/OFF |
| Breaker solenoid★ | ON | - |

※ Refer to the page 5-99 for the attachment kinds and max flow.

★ When breaker operating button is pushed.

GROUP 10 ANTI-RESTART SYSTEM

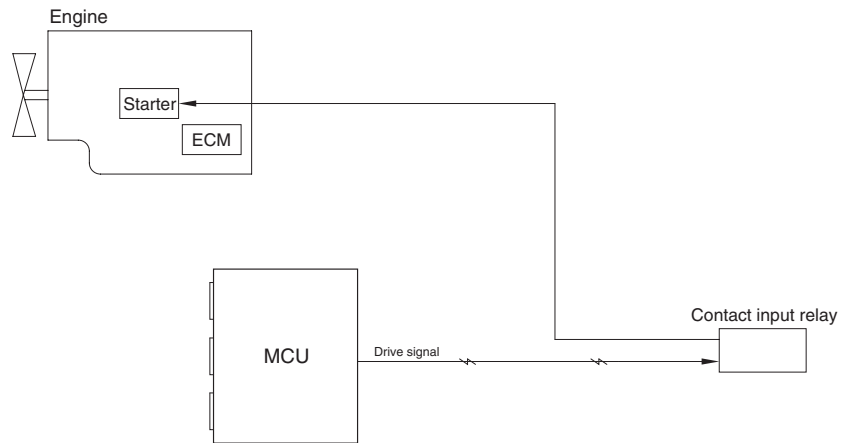

900L5MS12

1. ANTI-RESTART FUNCTION

After a few seconds from the engine starts to run, MCU turns off the contact input relay to protect the starter from inadvertent restarting.

GROUP 11 SELF-DIAGNOSTIC SYSTEM

1. OUTLINE

When any abnormality occurs in the ADVANCED CAPO system caused by electric parts malfunction and by open or short circuit, the MCU diagnoses the problem and sends the error codes to the cluster and also stores them in the memory.

2. MONITORING

1) Active fault



- The active faults of the MCU, engine ECM or air conditioner can be checked by this menu.

2) Logged fault

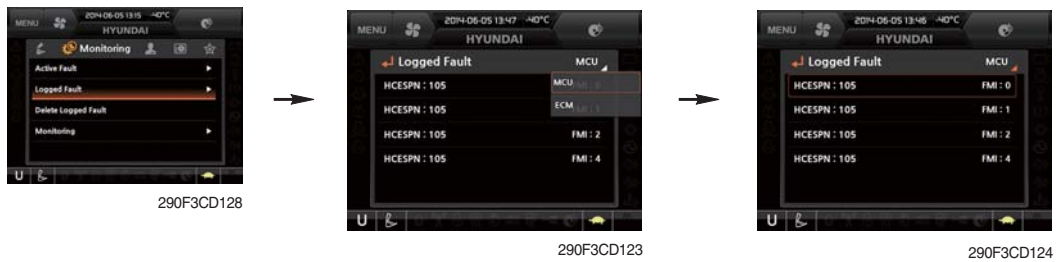

- The logged faults of the MCU, engine ECM or air conditioner can be checked by this menu.

3) Delete logged fault



- The logged faults of the MCU, engine ECM or air conditioner can be deleted by this menu.

3. MACHINE ERROR CODES TABLE

| DTC | | Diagnostic Criteria | Application | | |
|--------|--|---|-------------|---|---|
| HCESPN | FMI | | G | C | W |
| 101 | 3 | 10 seconds continuous, Hydraulic Oil Temp. Measurement Voltage > 3.8V | ● | | |
| | 4 | 10 seconds continuous, Hydraulic Oil Temp. Measurement Voltage < 0.3V | ● | | |
| | (Results / Symptoms) 1. Monitor – Hydraulic oil temperature display failure 2. Control Function – Fan revolutions control failure (Checking list) 1. CD-1 (#2) - CN-52 (#24) Checking Open/Short 2. CD-1 (#1) - CN-51 (#5) Checking Open/Short | | | | |
| 105 | 0 | 10 seconds continuous, Working Press. Sensor Measurement Voltage > 5.2V | ● | | |
| | 1 | 10 seconds continuous, 0.3V ≤ Working Press. Sensor Measurement Voltage < 0.8V | ● | | |
| | 4 | 10 seconds continuous, Working Press. Sensor Measurement Voltage < 0.3V | ● | | |
| | (Results / Symptoms) 1. Monitor – Working Press. display failure 2. Control Function – Auto Idle operation failure, Engine variable horse power control operation failure (Checking list) 1. CD-7 (#B) – CN-52 (#37) Checking Open/Short 2. CD-7 (#A) – CN-51 (#3) Checking Open/Short 3. CD-7 (#C) – CN-51 (#13) Checking Open/Short | | | | |
| 108 | 0 | 10 seconds continuous, Travel Oil Press. Sensor Measurement Voltage > 5.2V | | ● | |
| | 1 | 10 seconds continuous, 0.3V ≤ Travel Oil Press. Sensor Measurement Voltage < 0.8V | ● | | |
| | 4 | 10 seconds continuous, Travel Oil Press. Sensor Measurement Voltage < 0.3V | ● | | |
| | (Results / Symptoms) 1. Monitor – Travel Oil Press. display failure 2. Control Function – Auto Idle operation failure, Engine variable horse power control operation failure, IPC operation failure, Driving alarm operation failure (Checking list) 1. CD-6 (#B) – CN-52 (#38) Checking Open/Short 2. CD-6 (#A) – CN-51 (#3) Checking Open/Short 3. CD-6 (#C) – CN-51 (#13) Checking Open/Short | | | | |

※ Some error codes are not applied to this machine.

G : General

C : Crawler Type

W : Wheel Type

| DTC | | Diagnostic Criteria | Application | | |
|--------|---|---|-------------|---|---|
| HCESPN | FMI | | G | C | W |
| 120 | 0 | 10 seconds continuous, Main Pump 1 (P1) Press. Sensor Measurement Voltage > 5.2V | ● | | |
| | 1 | 10 seconds continuous, 0.3V ≤ Main Pump 1 (P1) Press. Sensor Measurement Voltage < 0.8V | ● | | |
| | 4 | 10 seconds continuous, Main Pump 1 (P1) Press. Sensor Measurement Voltage < 0.3V | ● | | |
| | (Results / Symptoms) 1. Monitor – Main Pump 1 (P1) Press. display failure 2. Control Function – Automatic voltage increase operation failure, Overload at compensation control failure (Checking list) 1. CD-42 (#B) – CN-52 (#29) Checking Open/Short 2. CD-42 (#A) – CN-51 (#3) Checking Open/Short 3. CD-42 (#C) – CN-51 (#13) Checking Open/Short | | | | |
| 121 | 0 | 10 seconds continuous, Main Pump 2 (P2) Press. Sensor Measurement Voltage > 5.2V | ● | | |
| | 1 | 10 seconds continuous, 0.3V ≤ Main Pump 2 (P2) Press. Sensor Measurement Voltage < 0.8V | ● | | |
| | 4 | 10 seconds continuous, Main Pump 2 (P2) Press. Sensor Measurement Voltage < 0.3V | ● | | |
| | (Results / Symptoms) 1. Monitor – Main Pump 2 (P2) Press. display failure 2. Control Function – Automatic voltage increase operation failure, Overload at compensation control failure (Checking list) 1. CD-43 (#B) – CN-52 (#12) Checking Open/Short 2. CD-43 (#A) – CN-51 (#3) Checking Open/Short 3. CD-43 (#C) – CN-51 (#13) Checking Open/Short | | | | |
| 122 | 1 | (when you had conditions mounting pressure sensor) 10 seconds continuous, 0.3V ≤ Overload Press. Sensor Measurement Voltage < 0.8V | ● | | |
| | 4 | (when you had conditions mounting pressure sensor) 10 seconds continuous, Overload Press. Sensor Measurement Voltage < 0.3V | ● | | |
| | (Results / Symptoms) 1. Monitor – Overload Press. display failure 2. Control Function – Overload warning alarm failure (Checking list) 1. CD-31 (#B) – CN-52 (#16) Checking Open/Short 2. CD-31 (#A) – CN-51 (#3) Checking Open/Short 3. CD-31 (#C) – CN-51 (#13) Checking Open/Short | | | | |

※ Some error codes are not applied to this machine.

G : General

C : Crawler Type

W : Wheel Type

| DTC | | Diagnostic Criteria | Application | | |
|--------|---|---|-------------|---|---|
| HCESPN | FMI | | G | C | W |
| 123 | 0 | 10 seconds continuous, Negative 1 Press. Sensor Measurement Voltage > 5.2V | ● | | |
| | 1 | 10 seconds continuous, $0.3V \leq$ Negative 1 Press. Sensor Measurement Voltage < 0.8V | ● | | |
| | 4 | 10 seconds continuous, Negative 1 Press. Sensor Measurement Voltage < 0.3V | ● | | |
| | (Results / Symptoms) 1. Monitor – Negative 1 Press. display failure 2. Control Function – IPC operation failure, Option attachment flow control operation failure (Checking list) 1. CD-70 (#B) – CN-52 (#33) Checking Open/Short 2. CD-70 (#A) – CN-51 (#3) Checking Open/Short 3. CD-70 (#C) – CN-51 (#13) Checking Open/Short | | | | |
| 124 | 0 | 10 seconds continuous, Negative 2 Press. Sensor Measurement Voltage > 5.2V | ● | | |
| | 1 | 10 seconds continuous, $0.3V \leq$ Negative 2 Press. Sensor Measurement Voltage < 0.8V | ● | | |
| | 4 | 10 seconds continuous, Negative 2 Press. Sensor Measurement Voltage < 0.3V | ● | | |
| | (Results / Symptoms) 1. Monitor – Negative 2 Press. display failure 2. Control Function – Option attachment flow control operation failure (Checking list) 1. CD-71 (#B) – CN-52 (#17) Checking Open/Short 2. CD-71 (#A) – CN-51 (#3) Checking Open/Short 3. CD-71 (#C) – CN-51 (#13) Checking Open/Short | | | | |
| 127 | 0 | 10 seconds continuous, Boom Up Pilot Press. Sensor Measurement Voltage > 5.2V | ● | | |
| | 1 | 10 seconds continuous, $0.3V \leq$ Boom Up Pilot Press. Sensor Measurement Voltage < 0.8V | ● | | |
| | 4 | 10 seconds continuous, Boom Up Pilot Press. Sensor Measurement < 0.3V | ● | | |
| | (Results / Symptoms) 1. Monitor – Boom Up Pilot Press. display failure 2. Control Function – Engine/Pump variable horse power control operation failure, IPC operation failure, Boom first operation failure (Checking list) 1. CD-32 (#B) – CN-52 (#19) Checking Open/Short 2. CD-32 (#A) – CN-51 (#3) Checking Open/Short 3. CD-32 (#C) – CN-51 (#13) Checking Open/Short | | | | |

※ Some error codes are not applied to this machine.

G : General

C : Crawler Type

W : Wheel Type

| DTC | | Diagnostic Criteria | Application | | |
|--------|--|---|-------------|---|---|
| HCESPN | FMI | | G | C | W |
| 128 | 0 | (when you had conditions mounting pressure sensor) 10 seconds continuous, Boom Down Pilot Press. Sensor Measurement Voltage > 5.2V | ● | | |
| | 1 | (when you had conditions mounting pressure sensor) 10 seconds continuous, $0.3V \leq$ Boom Down Pilot Press. Sensor Measurement Voltage < 0.8V | ● | | |
| | 4 | (when you had conditions mounting pressure sensor) 10 seconds continuous, Boom Down Pilot Press. Sensor Measurement Voltage < 0.3V | ● | | |
| | (Results / Symptoms) 1. Monitor – Boom Down Pilot Press. display failure 2. Control Function – Boom floating operation failure (Checking list) 1. CD-85 (#B) – CN-53 (#23) Checking Open/Short 2. CD-85 (#A) – CN-53 (#3) Checking Open/Short 3. CD-85 (#C) – CN-53 (#13) Checking Open/Short | | | | |
| 129 | 0 | 10 seconds continuous, Arm In Pilot Press. Sensor Measurement Voltage > 4.8V | ● | | |
| | 1 | 10 seconds continuous, $0.3V \leq$ Arm In Pilot Press. Sensor Measurement Voltage < 0.8V | ● | | |
| | 4 | 10 seconds continuous, Arm In Pilot Press. Sensor Measurement Voltage < 0.3V | ● | | |
| | (Results / Symptoms) 1. Monitor – Arm In Pilot Press. display failure 2. Control Function – IPC operation failure (Checking list) 1. CD-90 (#B) – CN-52 (#28) Checking Open/Short 2. CD-90 (#A) – CN-51 (#3) Checking Open/Short 3. CD-90 (#C) – CN-51 (#13) Checking Open/Short | | | | |
| 133 | 0 | 10 seconds continuous, Arm In/Out & Bucket In Pilot Press. Sensor Measurement Voltage > 5.2V | ● | | |
| | 1 | 10 seconds continuous, $0.3V \leq$ Arm In/Out & Bucket In Pilot Press. Sensor Measurement Voltage < 0.8V | ● | | |
| | 4 | 10 seconds continuous, Arm In/Out & Bucket In Pilot Press. Sensor Measurement Voltage < 0.3V | ● | | |
| | (Results / Symptoms) 1. Monitor – Arm In/Out & Bucket In Pilot Press. display failure 2. Control Function – Engine variable horse power control operation failure (Checking list) 1. CD-35 (#B) – CN-52 (#14) Checking Open/Short 2. CD-35 (#A) – CN-51 (#3) Checking Open/Short 3. CD-35 (#C) – CN-51 (#13) Checking Open/Short | | | | |

※ Some error codes are not applied to this machine.

G : General

C : Crawler Type

W : Wheel Type

| DTC | | Diagnostic Criteria | Application | | |
|--------|---|---|-------------|---|---|
| HCESPN | FMI | | G | C | W |
| 135 | 0 | 10 seconds continuous, Swing Pilot Press. Sensor Measurement Voltage > 5.2V | ● | | |
| | 1 | 10 seconds continuous, 0.3V ≤ Swing Pilot Press. Sensor Measurement Voltage < 0.8V | ● | | |
| | 4 | 10 seconds continuous, Swing Pilot Press. Sensor Measurement Voltage < 0.3V | ● | | |
| | (Results / Symptoms) 1. Monitor – Swing Pilot Press. display failure 2. Control Function – IPC operation, Boom first operation failure (Checking list) 1. CD-24 (#B) – CN-52 (#36) Checking Open/Short 2. CD-24 (#A) – CN-51 (#3) Checking Open/Short 3. CD-24 (#C) – CN-51 (#13) Checking Open/Short | | | | |
| 138 | 0 | Monitor – Select Attachment(breaker / crusher) 10 seconds continuous, Attachment Pilot Press. Sensor Measurement Voltage > 5.2V | ● | | |
| | 1 | Monitor – Select Attachment(breaker / crusher) 10 seconds continuous, 0.3V ≤ Attachment Pilot Press. Sensor Measurement Voltage < 0.8V | ● | | |
| | 4 | Monitor – Select Attachment(breaker / crusher) 10 seconds continuous, Attachment Pilot Press. Sensor Measurement Voltage < 0.3V | ● | | |
| | (Results / Symptoms) 1. Monitor – Attachment Pilot Press. display failure 2. Control Function – Option attachment flow control operation failure (Checking list) 1. CD-69 (#B) – CN-53 (#14) Checking Open/Short 2. CD-69 (#A) – CN-53 (#3) Checking Open/Short 3. CD-69 (#C) – CN-53 (#13) Checking Open/Short | | | | |
| 139 | 1 | 10 seconds continuous, 0.3V ≤ Option Pilot Press. Sensor Measurement Voltage < 0.8V | | | ● |
| | 4 | 10 seconds continuous, Option Pilot Press. Sensor Measurement Voltage < 0.3V | | | ● |
| | (Results / Symptoms) 1. Monitor – Option Pilot Press. display failure 2. Control Function – Auto Idle operation failure (Checking list) 1. CD-100 (#B) – CN-52 (#21) Checking Open/Short 2. CD-100 (#A) – CN-51 (#3) Checking Open/Short 3. CD-100 (#C) – CN-1 (#6) Checking Open/Short | | | | |

※ Some error codes are not applied to this machine.

G : General

C : Crawler Type

W : Wheel Type

| DTC | | Diagnostic Criteria | Application | | |
|--|-----|--|-------------|---|---|
| HCESPN | FMI | | G | C | W |
| 140 | 5 | (Detection) (When Main Pump EPPR Current is more than 10 mA) 10 seconds continuous, Pump EPPR drive current < 0 mA (Cancellation) (When Main Pump EPPR Current is more than 10 mA) 3 seconds continuous, Main Pump EPPR drive current ≥10 mA | ● | | |
| | 6 | (Detection) 10 seconds continuous, Main Pump EPPR drive current > 1.0A (Cancellation) 3 seconds continuous, Main Pump EPPR drive current ≤ 1.0 A | ● | | |
| (Results / Symptoms) 1. Control Function – Pump horse power setting specification difference (Fuel efficiency/speed specification failure) (Checking list) 1. CN-75 (#2) – CN-52 (#9) Checking Open/Short 2. CN-75 (#1) – CN-52 (#10) Checking Open/Short | | | | | |
| 141 | 5 | (Model Parameter) mounting Boom Priority EPPR (Detection) (When Boom Priority EPPR Current is more than 10 mA) 10 seconds continuous, Boom Priority EPPR drive current < 0 mA (Cancellation) (When Boom Priority EPPR Current is more than 10 mA) 3 seconds continuous, Boom Priority EPPR drive current ≥ 10 mA | ● | | |
| | 6 | (Detection) 10 seconds continuous, Boom Priority EPPR drive current > 1.0 A (Cancellation) 3 seconds continuous, Boom Priority EPPR drive current ≤ 1.0 A | ● | | |
| (Results / Symptoms) 1. Control Function – Boom first control operation failure (Checking list) 1. CN-133 (#2) – CN-52 (#34) Checking Open/Short 2. CN-133 (#1) – CN-52 (#35) Checking Open/Short | | | | | |

※ Some error codes are not applied to this machine.

G : General

C : Crawler Type

W : Wheel Type

| DTC | | Diagnostic Criteria | Application | | |
|--------|--|---|-------------|---|---|
| HCESPN | FMI | | G | C | W |
| 143 | 5 | (Detection) (When Travel EPPR Current is more than 10 mA) 10 seconds continuous, Travel EPPR drive current = 0 mA (Cancellation) (When Travel EPPR Current is more than 100 mA) 3 seconds continuous, Travel EPPR drive current ≥ 10 mA | | | ● |
| | 6 | (Detection) 10 seconds continuous, Travel EPPR drive current > 1.0 A (Cancellation) 3 seconds continuous, Travel EPPR drive current ≤ 1.0 A | | | ● |
| | (Results / Symptoms) 1. Control Function – cruise control operation failure (Checking list) 1. CN-246 (#B) – CN-306 (#9) Checking Open/Short 2. CN-246 (#A) – CN-306 (#8) Checking Open/Short 3. CN-246 (#C) – CN-306 (#11) Checking Open/Short | | | | |
| 145 | 5 | (Model Parameter) mounting Remote Cooling Fan EPPR (Detection) (When Remote Cooling Fan EPPR Current is more than 10 mA) 10 seconds continuous, Remote Cooling Fan EPPR drive current = 0 mA (Cancellation) (When Remote Cooling Fan EPPR Current is more than 10 mA) 3 seconds continuous, Remote Cooling Fan EPPR drive current ≥ 10 mA | ● | | |
| | 6 | (Detection) 10 seconds continuous, Remote Cooling Fan EPPR drive current > 1.0 A (Cancellation) 3 seconds continuous, Remote Cooling Fan EPPR drive current ≤ 1.0 A | ● | | |
| | (Results / Symptoms) 1. Control Function – Remote fan control operation failure (Checking list) 1. CD-52 (#1) – CN-154 (#5) Checking Open/Short 2. CD-52 (#2) – CN-154 (#4) Checking Open/Short | | | | |

※ Some error codes are not applied to this machine.

G : General

C : Crawler Type

W : Wheel Type

| DTC | | Diagnostic Criteria | Application | | |
|--|-----|---|-------------|---|---|
| HCESPN | FMI | | G | C | W |
| 164 | 4 | (Detection) (When Working Cutoff Relay is Off) 10 seconds continuous, Working Cutoff Relay drive unit Measurement Voltage $\leq 3.0V$ (Cancellation) (When Working Cutoff Relay is Off) 3 seconds continuous, Working Cutoff Relay drive unit Measurement Voltage $> 3.0V$ | | | ● |
| | 6 | (Detection) (When Working Cutoff Relay is On) 10 seconds continuous, Working Cutoff Relay drive current $> 6.5 A$ (Cancellation) (When Working Cutoff Relay is On) 3 seconds continuous, Working Cutoff Relay drive current $\leq 6.5 A$ | | | ● |
| (Results / Symptoms) 1. Control Function – (Wheel Excavator) In driving mode, attachment hydraulic pilot pressure cut off failure (Checking list) 1. CR-47 (#85) – CN-54 (#9) Checking Open/Short 2. CR-47 (#30, #86) – Fuse box (#28) Checking Open/Short | | | | | |
| 166 | 4 | (Detection) (When Power Max Solenoid is Off) 10 seconds continuous, Power Max Solenoid drive unit Measurement Voltage $\leq 3.0V$ (Cancellation) (When Power Max Solenoid is Off) 3 seconds continuous, Power Max Solenoid drive unit Measurement Voltage $> 3.0V$ | ● | | |
| | 6 | (Detection) (When Power Max Solenoid is On) 5 seconds continuous, Power Max Solenoid drive current $> 4.5 A$ (Cancellation) (When Power Max Solenoid is On) 3 seconds continuous, Power Max Solenoid drive current $\leq 4.5 A$ | ● | | |
| (Results / Symptoms) 1. Control Function – Voltage increase operation failure (Checking list) 1. CN-88 (#1) – CN-52 (#2) Checking Open/Short 2. CN-88 (#2) – Fuse box (#28) Checking Open/Short | | | | | |

※ Some error codes are not applied to this machine.

G : General

C : Crawler Type

W : Wheel Type

| DTC | | Diagnostic Criteria | Application | | |
|--------|---|---|-------------|---|---|
| HCESPN | FMI | | G | C | W |
| 167 | | (Detection) (When Travel Speed Solenoid is Off) 10 seconds continuous, Travel Speed Solenoid drive unit Measurement Voltage $\leq 3.0V$ (Cancellation) (When Travel Speed Solenoid is Off) 3 seconds continuous, Travel Speed Solenoid drive unit Measurement Voltage $> 3.0V$ | | ● | |
| | 4 | (When Parking mode is not) (Detection) (When Travel Speed Solenoid is Off) 10 seconds continuous, Travel Speed Solenoid drive unit Measurement Voltage $\leq 3.0V$ (Cancellation) (When Travel Speed Solenoid is Off) 3 seconds continuous, Travel Speed Solenoid drive unit Measurement Voltage $> 3.0V$ | | | ● |
| | 6 | (Detection) (When Travel Speed Solenoid is On) 10 seconds continuous, Travel Speed Solenoid drive current $> 4.5 A$ (Cancellation) (When Travel Speed Solenoid is On) 3 seconds continuous, Travel Speed Solenoid drive current $\leq 4.5 A$ | ● | | |
| | (Results / Symptoms) 1. Control Function – driving in 1/2 transmission operation failure (Checking list) 1. CN-70 (#1) – CN-52 (#20) Checking Open/Short 2. CN-70 (#2) – Fuse box (#28) Checking Open/Short | | | | |

※ Some error codes are not applied to this machine.

G : General

C : Crawler Type

W : Wheel Type

| DTC | | Diagnostic Criteria | Application | | |
|---|-----|--|-------------|---|---|
| HCESPN | FMI | | G | C | W |
| 169 | 4 | Monitor – Selecting attachment(breaker / crusher) (Detection) (When Attachment Conflux Solenoid is Off) 10 seconds continuous, Attachment Conflux Solenoid drive unit Measurement Voltage \leq 3.0V (Cancellation) (When Attachment Conflux Solenoid is Off) 3 seconds continuous, Attachment Conflux Solenoid drive unit Measurement Voltage > 3.0V | ● | | |
| | 6 | (Detection) (When Attachment Conflux Solenoid is On) 10 seconds continuous, Attachment Conflux Solenoid drive Current > 6.5 A (Cancellation) (When Attachment Conflux Solenoid is On) 3 seconds continuous, Attachment Conflux Solenoid drive Current \leq 6.5 A | ● | | |
| (Results / symptoms) 1. Control Function – Option attachment flow control – Joining operation failure (Eco breaker mode, crusher mode) (Checking list) 1. CN-237 (#1) – CN-53 (#7) Checking Open/Short 2. CN-237 (#2) – Fuse box (#31) Checking Open/Short | | | | | |
| 170 | 4 | (Model Parameter) mounting Arm Regenerating Solenoid (Detection) (When Arm Regeneration Solenoid is Off) 10 seconds continuous, Arm Regeneration Solenoid drive unit Measurement Voltage \leq 3.0V (Cancellation) (When Arm Regeneration Solenoid is Off) 3 seconds continuous, Arm Regeneration Solenoid drive unit Measurement Voltage > 3.0V | ● | | |
| | 6 | (Detection) (When Arm Regeneration Solenoid is On) 10 seconds continuous, Arm Regeneration Solenoid drive current > 4.5 A (Cancellation) (When Arm Regeneration Solenoid is On) 3 seconds continuous, Arm Regeneration Solenoid drive current \leq 4.5 A | ● | | |
| (Results / symptoms) 1. Control Function – Arm regeneration operation failure (Checking list) 1. CN-135 (#1) – CN-52 (#07) Checking Open/Short 2. CN-135 (#2) – Fuse box (#28) Checking Open/Short | | | | | |

※ Some error codes are not applied to this machine.

G : General

C : Crawler Type

W : Wheel Type

| DTC | | Diagnostic Criteria | Application | | |
|--|-----|--|-------------|---|---|
| HCESPN | FMI | | G | C | W |
| 171 | 4 | Monitor – Selecting attachment(crusher) (Detection) (When Attachment Safety Solenoid is Off) 10 seconds continuous, Attachment Safety Solenoid drive unit Measurement Voltage \leq 3.0V (Cancellation) (When Attachment Safety Solenoid is Off) 3 seconds continuous, Attachment Safety Solenoid drive unit Measurement Voltage $>$ 3.0V | ● | | |
| | 6 | (Detection) (When Attachment Safety Solenoid is On) 10 seconds continuous, Attachment Safety Solenoid drive current $>$ 6.5 A (Cancellation) (When Attachment Safety Solenoid is On) 3 seconds continuous, Attachment Safety Solenoid drive current \leq 6.5 A | ● | | |
| (Results / Symptoms) 1. Control Function – Option attachment flow control – Option spool pilot pressure cut off failure (crusher mode) (Checking list) 1. CN-149 (#1) – CN-53 (#8) Checking Open/Short 2. CN-149 (#2) – Fuse box (#31) Checking Open/Short | | | | | |
| 179 | 4 | Monitor – Selecting attachment(breaker / crusher) (Detection) (When Breaker Operating Solenoid is Off) 10 seconds continuous, Attachment Safety Solenoid drive unit Measurement Voltage \leq 3.0V (Cancellation) (When Breaker Operating Solenoid is Off) 3 seconds continuous, Attachment Safety Solenoid drive unit Measurement Voltage $>$ 3.0V | ● | | |
| | 6 | (Detection) (When Breaker Operating Solenoid is On) 10 seconds continuous, Attachment Safety Solenoid drive current $>$ 6.5 A (Cancellation) (When Breaker Operating Solenoid is On) 3 seconds continuous, Attachment Safety Solenoid drive current \leq 6.5 A | ● | | |
| (Results / Symptoms) 1. Control Function – Option attachment flow control – Breaker operation failure (breaker mode) (Checking list) 1. CN-66 (#1) – CN-53 (#9) Checking Open/Short 2. CN-66 (#2) – Fuse box (#28) Checking Open/Short | | | | | |

※ Some error codes are not applied to this machine.

G : General

C : Crawler Type

W : Wheel Type

| DTC | | Diagnostic Criteria | Application | | |
|--|-----|--|-------------|---|---|
| HCESPN | FMI | | G | C | W |
| 181 | 4 | (Model Parameter) mounting Reverse Cooling Fan Solenoid (Detection) (When Reverse Cooling Fan Solenoid is Off) 10 seconds continuous, Reverse Cooling Fan Solenoid drive unit Measurement Voltage \leq 3.0V (Cancellation) (When Reverse Cooling Fan Solenoid is Off) 3 seconds continuous, Reverse Cooling Fan Solenoid drive unit Measurement Voltage $>$ 3.0V | ● | | |
| | 6 | (Detection) (When Reverse Cooling Fan Solenoid is On) 10 seconds continuous, Reverse Cooling Fan Solenoid drive current $>$ 4.5 A (Cancellation) (When Reverse Cooling Fan Solenoid is On) 3 seconds continuous, Reverse Cooling Fan Solenoid drive current \leq 4.5 A | ● | | |
| (Results / Symptoms) 1. Control Function – Cooling Fan reverse control operation failure (Check list) 1. CN-52 (#1) – CN-51 (#4) Checking Open/Short 2. CN-52 (#2) – CN-51 (#15) Checking Open/Short | | | | | |
| 188 | 5 | (Detection) (When Attachment Flow EPPR 1 current is equal or more than 300 mA) 10 seconds continuous, Attachment Flow EPPR drive current $<$ 100 mA (Cancellation) (When Attachment Flow EPPR 1 current is equal or more than 300 mA) 3 seconds continuous, Attachment Flow EPPR drive current \geq 100 mA | ● | | |
| | 6 | (Detection) 10 seconds continuous, Attachment Flow EPPR 1 drive current $>$ 1.0 A (Cancellation) 3 seconds continuous, Attachment Flow EPPR 1 drive current \leq 1.0 A | ● | | |
| (Results / Symptoms) 1. Control Function – IPC operation failure, Option attachment flow control operation failure (Checking list) 1. CN-242 (#2) – CN-52 (#39) Checking Open/Short 2. CN-242 (#1) – CN-52 (#40) Checking Open/Short | | | | | |

※ Some error codes are not applied to this machine.

G : General

C : Crawler Type

W : Wheel Type

| DTC | | Diagnostic Criteria | Application | | |
|--|-----|--|-------------|---|---|
| HCESPN | FMI | | G | C | W |
| 189 | 5 | (Detection) (When Attachment Flow EPPR 2 current is equal or more than 300 mA) 10 seconds continuous, Attachment Flow EPPR drive current < 100 mA (Cancellation) (When Attachment Flow EPPR 2 current is equal or more than 300 mA) 3 seconds continuous, Attachment Flow EPPR drive current ≥ 100 mA | ● | | |
| | 6 | (Detection) 10 seconds continuous, Attachment Flow EPPR 2 drive current > 1.0 A (Cancellation) 3 seconds continuous, Attachment Flow EPPR 2 drive current ≤ 1.0 A | ● | | |
| (Results / Symptoms) 1. Control Function – Option attachment flow control operation failure (Checking list) 1. CN-378 (#2) – CN-52 (#6) Checking Open/Short 2. CN-378 (#1) – CN-52 (#7) Checking Open/Short | | | | | |
| 196 | 0 | HW145 10 seconds continuous, Attachment flow control EPPR 1 press. Sensor Measurement Voltage > 5.2V | | | |
| | 1 | HW145 10 seconds continuous, 0.3V ≤ Attachment flow control EPPR 1 press. Sensor Measurement Voltage < 0.8V | | | |
| | 4 | HW145 10 seconds continuous, Attachment flow control EPPR 1 press. Sensor Measurement Voltage < 0.3V | | | |
| (Results / Symptoms) 1. Control Function – Driving second pump joining function operation failure (Checking list) 1. CD-93 (#B) – CN-52 (#11) Checking Open/Short 2. CD-93 (#A) – CN-51 (#3) Checking Open/Short 3. CD-93 (#C) – CN-51 (#13) Checking Open/Short | | | | | |
| 200 | 0 | 10 seconds continuous, Pump EPPR Press. Sensor Measurement Voltage > 5.2V | ● | | |
| | 1 | 10 seconds continuous, 0.3V ≤ Pump EPPR Press. Sensor Measurement Voltage < 0.8V | ● | | |
| | 4 | 10 seconds continuous, Pump EPPR Press. Sensor Measurement Voltage < 0.3V | ● | | |
| (Results / Symptoms) 1. Monitor – Pump EPPR Press. display failure 2. Control Function – Pump input horse power control failure, Overload at compensation control operation failure (Fuel efficiency/speed performance failure) (Checking list) 1. CD-44 (#B) – CN-52 (#32) Checking Open/Short 2. CD-44 (#A) – CN-51 (#3) Checking Open/Short 3. CD-44 (#C) – CN-51 (#13) Checking Open/Short | | | | | |

※ Some error codes are not applied to this machine.

G : General

C : Crawler Type

W : Wheel Type

| DTC | | Diagnostic Criteria | Application | | |
|--------|---|---|-------------|---|---|
| HCESPN | FMI | | G | C | W |
| 205 | 0 | (Mounting pressure sensor) 10 seconds continuous, Boom Cylinder Rod Press. Sensor Measurement Voltage > 5.2V | ● | | |
| | 1 | (Mounting pressure sensor) 10 seconds continuous, $0.3V \leq$ Boom Cylinder Rod Press. Sensor Measurement Voltage < 0.8V | ● | | |
| | 4 | (Mounting pressure sensor) 10 seconds continuous, Boom Cylinder Rod Press. Sensor Measurement Voltage < 0.3V | ● | | |
| | (Results / Symptoms) 1. Monitor – Boom Cylinder Rod Press. display failure 2. Control Function – Boom floating control operation failure (Checking list) 1. CD-124 (#B) – CN-53 (#5) Checking Open/Short 2. CD-124 (#A) – CN-53 (#3) Checking Open/Short 3. CD-124 (#C) – CN-53 (#13) Checking Open/Short | | | | |
| 218 | 4 | Mounting pressure sensor (HCESPN128 or HCESPN 205) (Detection) (When Boom Up Floating Solenoid is Off) 10 seconds continuous, Boom Up Floating Solenoid drive unit Measurement Voltage \leq 3.0V (Cancellation) (When Boom Up Floating Solenoid is Off) 3 seconds continuous, Boom Up Floating Solenoid drive unit Measurement Voltage > 3.0V | ● | | |
| | 6 | (Detection) (When Boom Up Floating Solenoid is On) 10 seconds continuous, Boom Up Floating Solenoid drive current > 6.5 A (Cancellation) (When Boom Up Floating Solenoid is On) 3 seconds continuous, Boom Up Floating Solenoid drive current \leq 6.5 A | ● | | |
| | (Results / Symptoms) 1. Control Function – Boom floating control operation failure (Checking list) 1. CN-368 (#1) – CN-53 (#20) Checking Open/Short 2. CN-368 (#2) – Fuse box (#31) Checking Open/Short | | | | |

※ Some error codes are not applied to this machine.

G : General

C : Crawler Type

W : Wheel Type

| DTC | | Diagnostic Criteria | Application | | |
|--|-----|---|-------------|---|---|
| HCESPN | FMI | | G | C | W |
| 220 | 4 | Mounting pressure sensor (HCESPN 128 or 205) (Detection) (When Boom Down Pilot Pressure Cutoff Solenoid is Off) 10 seconds continuous, Boom Down Pilot Pressure Cutoff Solenoid drive unit Measurement Voltage $\leq 3.0V$ (Cancellation) (When Boom Down Pilot Pressure Cutoff Solenoid is Off) 3 seconds continuous, Boom Down Pilot Pressure Cutoff Solenoid drive unit Measurement Voltage $> 3.0V$ | ● | | |
| | 6 | (Detection) (When Boom Down Pilot Pressure Cutoff Solenoid is On) 10 seconds continuous, Boom Down Pilot Pressure Cutoff Solenoid drive current $> 6.5 A$ (Cancellation) (When Boom Down Pilot Pressure Cutoff Solenoid is On) 3 seconds continuous, Boom Down Pilot Pressure Cutoff Solenoid drive current $\leq 6.5 A$ | ● | | |
| (Results / Symptoms) 1. Control Function – Boom floating control operation failure (Checking list) 1. CN-369 (#1) – CN-53 (#35) Checking Open/Short 2. CN-369 (#2) – Fuse box (#17) Checking Open/Short | | | | | |
| 221 | 5 | Monitor – Selecting attachment(breaker / crusher) (Detection) (When ATT Relief Setting EPPR 1 Current is equal or more than 10 mA) 10 seconds continuous, ATT Relief Setting EPPR 1 drive current = 0 mA (Cancellation) ATT Relief Setting EPPR 1 Current is equal or more than 10 mA) 3 seconds continuous, ATT Relief Setting EPPR 1 drive current $\geq 10 mA$ | ● | | |
| | 6 | (Detection) 10 seconds continuous, ATT Relief Setting EPPR 1 drive current $> 1.0 A$ (Cancellation) 3 seconds continuous, ATT Relief Setting EPPR 1 drive current $\leq 1.0 A$ | ● | | |
| (Results / Symptoms) 1. Control Function – Option attachment flow control – P1 relief pressure setting failure (Checking list) 1. CN-365 (#2) – CN-53 (#39) Checking Open/Short 2. CN-365 (#1) – CN-53 (#40) Checking Open/Short | | | | | |

※ Some error codes are not applied to this machine.

G : General

C : Crawler Type

W : Wheel Type

| DTC | | Diagnostic Criteria | Application | | |
|--|---|---|-------------|---|---|
| HCESPN | FMI | | G | C | W |
| 222 | 5 | Monitor – Selecting attachment(crusher) (Detection) (When ATT Relief Setting EPPR 2 Current is equal or more than 10 mA) 10 seconds continuous, ATT Relief Setting EPPR 2 drive current = 0 mA (Cancellation) (When ATT Relief Setting EPPR 2 Current is equal or more than 10 mA) 3 seconds continuous, ATT Relief Setting EPPR 2 drive current ≥ 10mA | ● | | |
| | 6 | (Detection) 10 seconds continuous, ATT Relief Setting EPPR 2 drive current > 1.0 A (Cancellation) 3 seconds continuous, ATT Relief Setting EPPR 2 drive current ≤ 1.0 A | ● | | |
| (Results / Symptoms) 1. Control Function – Option attachment flow control – P2 relief pressure setting failure (Checking list) 1. CN-366 (#2) – CN-53 (#32) Checking Open/Short 2. CN-366 (#1) – CN-53 (#33) Checking Open/Short | | | | | |
| 301 | 3 | 10 seconds continuous, Fuel Level Measurement Voltage > 3.8V | ● | | |
| | 4 | 10 seconds continuous, Fuel Level Measurement Voltage < 0.3V | ● | | |
| | (Results / Symptoms) 1. Monitor – Fuel remaining display failure (Checking list) 1. CD-2 (#2) – CN-52 (#26) Checking Open/Short 2. CD-2 (#1) – CN-51 (#5) Checking Open/Short | | | | |
| 325 | 4 | (Model Parameter) mounting Fuel Warmer Relay (Detection) (When Fuel Warmer Relay is Off) 10 seconds continuous, Fuel Warmer Relay drive unit Measurement Voltage ≤ 3.0V (Cancellation) (When Fuel Warmer Relay is Off) 3 seconds continuous, Fuel Warmer Relay drive unit Measurement Voltage > 3.0V | ● | | |
| | 6 | (Detection) (When Fuel Warmer Relay is On) 10 seconds continuous, Fuel Warmer Relay drive current > 4.5 A (Cancellation) (When Fuel Warmer Relay is On) 3 seconds continuous, Fuel Warmer Relay drive current ≤ 4.5 A | ● | | |
| (Results / Symptoms) 1. Control Function – Fuel warmer operation failure (Checking list) 1. CR-46 (#85) – CN-52 (#30) Checking Open/Short 2. CR-46 (#86) – Fuse box (#22) Checking Open/Short | | | | | |

※ Some error codes are not applied to this machine.

G : General

C : Crawler Type

W : Wheel Type

| DTC | | Diagnostic Criteria | Application | | |
|--------|---|---|-------------|---|---|
| HCESPN | FMI | | G | C | W |
| 501 | 0 | 10 seconds continuous, Transmission Oil Press. Sensor Measurement Voltage > 5.2V | | | ● |
| | 1 | 10 seconds continuous, 0.3V ≤ Transmission Oil Press. Sensor Measurement Voltage < 0.8V | | | ● |
| | 4 | 10 seconds continuous, Transmission Oil Press. Sensor Measurement Voltage < 0.3V | | | ● |
| | (Results / Symptoms) 1. Monitor – Transmission Oil Press. display failure, Transmission Oil low pressure warning failure (Checking list) 1. CD-5 (#B) – CN-54 (#27) Checking Open/Short 2. CD-5 (#A) – CN-54 (#3) Checking Open/Short 3. CD-5 (#C) – CN-54 (#13) Checking Open/Short | | | | |
| 503 | 0 | 10 seconds continuous, Brake Oil Press. Sensor Measurement Voltage > 5.2V | | | ● |
| | 1 | 10 seconds continuous, 0.3V ≤ Brake Oil Press. Sensor Measurement Voltage < 0.8V | | | ● |
| | 4 | 10 seconds continuous, Brake Oil Press. Sensor Measurement Voltage < 0.3V | | | ● |
| | (Results / Symptoms) 1. Monitor – Brake Oil Press. display failure, Brake Oil low pressure warning failure (Checking list) 1. CD-3 (#B) – CN-54 (#4) Checking Open/Short 2. CD-3 (#A) – CN-54 (#3) Checking Open/Short 3. CD-3 (#C) – CN-54 (#13) Checking Open/Short | | | | |
| 505 | 0 | 10 seconds continuous, Working Brake Press. Sensor Measurement Voltage > 5.2V | | | ● |
| | 1 | 10 seconds continuous, 0.3V ≤ Working Brake Press. Sensor Measurement Voltage < 0.8V | | | ● |
| | 4 | 10 seconds continuous, Working Brake Press. Sensor Measurement Voltage < 0.3V | | | ● |
| | (Results / Symptoms) 1. Monitor – Working Brake Oil Press. display failure, Working Brake Oil low pressure warning failure (Checking list) 1. CD-38 (#B) – CN-54 (#5) Checking Open/Short 2. CD-38 (#A) – CN-54 (#3) Checking Open/Short 3. CD-38 (#C) – CN-54 (#13) Checking Open/Short | | | | |

※ Some error codes are not applied to this machine.

G : General

C : Crawler Type

W : Wheel Type

| DTC | | Diagnostic Criteria | Application | | |
|---|-----|---|-------------|---|---|
| HCESPN | FMI | | G | C | W |
| 514 | 4 | (Detection) (When Parking Relay is Off) 10 seconds continuous, Parking Relay drive unit Measurement Voltage \leq 3.0V (Cancellation) (When Parking Relay is Off) 3 seconds continuous, Parking Relay drive unit Measurement Voltage $>$ 3.0V | | | ● |
| | 6 | (Detection) (When Parking Relay is On) 10 seconds continuous, Parking Relay drive current $>$ 6.5 A (Cancellation) (When Parking Relay is On) 3 seconds continuous, Parking Relay drive current \leq 6.5 A | | | ● |
| (Results / Symptoms) 1. Control Function – Parking Relay operation failure (Checking list) 1. CR-66 (#1) – CN-54 (#20) Checking Open/Short 2. CR-66 (#2) – Fuse box (#30) Checking Open/Short | | | | | |
| 517 | 4 | (Detection) (When Traveling Cutoff Relay is Off) 10 seconds continuous, Traveling Cutoff Relay drive unit Measurement Voltage \leq 3.0V (Cancellation) (When Traveling Cutoff Relay is Off) 3 seconds continuous, Traveling Cutoff Relay drive unit Measurement Voltage $>$ 3.0V | | | ● |
| | 6 | (Detection) (When Traveling Cutoff Relay is On) 10 seconds continuous, Traveling Cutoff Relay drive current $>$ 6.5 A (Cancellation) (When Traveling Cutoff Relay is On) 3 seconds continuous, Traveling Cutoff Relay drive current \leq 6.5 A | | | ● |
| (Results / Symptoms) 1. Control Function – Traveling Cutoff Relay operation failure (Checking list) 1. CR-47 (#85) – CN-54 (#9) Checking Open/Short 2. CR-47 (#86) – Fuse box (#28) Checking Open/Short | | | | | |

※ Some error codes are not applied to this machine.

G : General

C : Crawler Type

W : Wheel Type

| DTC | | Diagnostic Criteria | Application | | |
|---|-----|---|-------------|---|---|
| HCESPN | FMI | | G | C | W |
| 525 | 4 | (Detection) (When Ram Lock Solenoid is Off) 10 seconds continuous, Ram Lock Solenoid drive unit Measurement Voltage $\leq 3.0V$ (Cancellation) (When Ram Lock Solenoid is Off) 3 seconds continuous, Ram Lock Solenoid drive unit Measurement Voltage $> 3.0V$ | | | ● |
| | 6 | (Detection) (When Ram Lock Solenoid is On) 10 seconds continuous, Ram Lock Solenoid drive current $> 6.5 A$ (Cancellation) (When Ram Lock Solenoid is On) 3 seconds continuous, Ram Lock Solenoid drive current $\leq 6.5 A$ | | | ● |
| (Results / Symptoms) 1. Control Function – Ram lock control operation failure (Checking list) 1. CN-69 (#1) – CN-54 (#8) Checking Open/Short 2. CN-69 (#2) – Fuse box (#33) Checking Open/Short | | | | | |
| 527 | 4 | (Detection) (When Creep Solenoid is Off) 10 seconds continuous, Creep Solenoid drive unit Measurement Voltage $\leq 3.0V$ (Cancellation) (When Creep Solenoid is Off) 3 seconds continuous, Creep Solenoid drive unit Measurement Voltage $> 3.0V$ | | | ● |
| | 6 | (Detection) (When Creep Solenoid is On) 10 seconds continuous, Creep Solenoid drive current $> 6.5 A$ (Cancellation) (When Creep Solenoid is On) 3 seconds continuous, Creep Solenoid drive current $\leq 6.5 A$ | | | ● |
| (Results / Symptoms) 1. Control Function – Creep mode operation failure (Checking list) 1. CN-206 (#1) – CN-54 (#7) Checking Open/Short 2. CN-206 (#2) – Fuse box (#30) Checking Open/Short | | | | | |

※ Some error codes are not applied to this machine.

G : General

C : Crawler Type

W : Wheel Type

| DTC | | Diagnostic Criteria | Application | | |
|--------|---|---|-------------|---|---|
| HCESPN | FMI | | G | C | W |
| 530 | 0 | 10 seconds continuous, Travel Forward Press. Sensor Measurement Voltage > 5.2V | | | ● |
| | 1 | 10 seconds continuous, 0.3V ≤ Travel Forward Press. Sensor Measurement Voltage < 0.8V | | | ● |
| | 4 | 10 seconds continuous, Travel Forward Press. Sensor Measurement Voltage < 0.3V | | | ● |
| | (Results / Symptoms) 1. Monitor – Travel Forward Press. display failure 2. Control Function – Driving interoperability power control operation failure (Checking list) 1. CD-73 (#B) – CN-54 (#6) Checking Open/Short 2. CD-73 (#A) – CN-54 (#3) Checking Open/Short 3. CD-73 (#C) – CN-54 (#13) Checking Open/Short | | | | |
| 531 | 1 | 10 seconds continuous, 0.3V ≤ Travel Reverse Press. Sensor Measurement Voltage < 0.8V | | | ● |
| | 4 | 10 seconds continuous, Travel Reverse Press. Sensor Measurement Voltage < 0.3V | | | ● |
| | (Results / Symptoms) 1. Monitor – Travel Reverse Press. display failure 2. Control Function – Driving interoperability power control operation failure (Checking list) 1. CD-74 (#B) – CN-54 (#23) Checking Open/Short 2. CD-74 (#A) – CN-54 (#3) Checking Open/Short 3. CD-74 (#C) – CN-54 (#13) Checking Open/Short | | | | |
| | | | | | |
| 705 | 0 | 10 seconds continuous, Battery input Voltage > 35V | ● | | |
| | 1 | 10 seconds continuous, Battery input Voltage < 18V | ● | | |
| | (Results / Symptoms) 1. Control Function – Startup impossibility (Checking list) 1. CS-74A (#1) – CN-51 (#1) Checking Open/Short | | | | |
| 707 | 1 | (When Engine is equal or more than 400 rpm) 10 seconds continuous, Alternator Node I Measurement Voltage < 18V (In case 12v goods, Alternator Node I Measurement Voltage < 9V) | ● | | |
| | (Results / Symptoms) 1. Control Function – Battery charging circuit failure (Checking list) 1. CS-74A (#1) – CN-51 (#2) Checking Open/Short | | | | |

※ Some error codes are not applied to this machine.

G : General

C : Crawler Type

W : Wheel Type

| DTC | | Diagnostic Criteria | Application | | |
|--------|---|--|-------------|---|---|
| HCESPN | FMI | | G | C | W |
| 714 | 3 | (Model Parameter) Mounting Acc. Dial 10 seconds continuous, Acc. Dial Measurement Voltage > 5.2V | ● | | |
| | 4 | (Model Parameter) Mounting Acc. Dial 10 seconds continuous, Acc. Dial Measurement Voltage < 0.3V | ● | | |
| | (Results / Symptoms) 1. Monitor – Acc. Dial Voltage display failure 2. Control Function – Engine rpm control failure (Checking list) 1. CN-7 (#15) – CN-52 (#23) Checking Open/Short | | | | |
| 722 | 4 | (Detection) (When Travel Alarm (Buzzer) Sound is Off) 10 seconds continuous, Travel Alarm (Buzzer) Sound Relay drive unit Measurement Voltage ≤ 3.0V (Cancellation) (When Travel Alarm (Buzzer) Sound Relay is Off) 3 seconds continuous, Travel Alarm (Buzzer) Sound Relay drive unit Measurement Voltage > 3.0V | ● | | |
| | 6 | (Detection) (When Travel Alarm (Buzzer) Sound is On) 10 seconds continuous, Travel Alarm (Buzzer) Sound Relay drive current > 4.5 A (Cancellation) (When Travel Alarm (Buzzer) Sound is On) 3 seconds continuous, Travel Alarm (Buzzer) Sound Relay drive current ≤ 4.5 A | ● | | |
| | (Results / Symptoms) 1. Control Function – Driving alarm operation failure (Checking list) 1. CN-81 (#1) – CN-52 (#31) Checking Open/Short 2. CN-81 (#2) – Fuse box (#28) Checking Open/Short | | | | |
| 831 | 2 | (When mounting the A/C Controller) 60 seconds continuous, A/C Controller Communication Data Error | ● | | |
| | (Results / Symptoms) 1. Control Function – A/C Controller operation failure (Checking list) 1. CN-11 (#8) – CN-51 (#22) Checking Open/Short 2. CN-11 (#7) – CN-51 (#32) Checking Open/Short | | | | |
| 840 | 2 | 60 seconds continuous, Cluster Communication Data Error | ● | | |
| | (Results / Symptoms) 1. Control Function – Cluster operation failure (Checking list) 1. CN-56A (#7) – CN-51 (#22) Checking Open/Short 2. CN-56A (#6) – CN-51 (#32) Checking Open/Short | | | | |

※ Some error codes are not applied to this machine.

G : General

C : Crawler Type

W : Wheel Type

| DTC | | Diagnostic Criteria | Application | | |
|--------|---|--|-------------|---|---|
| HCESPN | FMI | | G | C | W |
| 841 | 2 | 10 seconds continuous, ECM Communication Data Error | ● | | |
| | (Results / Symptoms) 1. Control Function – ECM operation failure (Checking list) 1. CN-16 (#6) – CN-51 (#21) Checking Open/Short 2. CN-16 (#7) – CN-51 (#31) Checking Open/Short | | | | |
| 845 | 2 | (When mounting the I/O Controller 1) 60 seconds continuous, I/O Controller 1 Communication Data Error | ● | | |
| | (Results / Symptoms) 1. Control Function – I/O Controller 1 operation failure (Checking list) 1. CN-53 (#21) – CN-51 (#23) Checking Open/Short 2. CN-53 (#31) – CN-51 (#33) Checking Open/Short | | | | |
| 848 | 2 | (When mounting the Haptic Controller) 60 seconds continuous, Haptic Controller Communication Data Error | ● | | |
| | (Results / Symptoms) 1. Control Function – Haptic Controller operation failure (Checking list) 1. CN-8 (#2) – CN-51 (#22) Checking Open/Short 2. CN-8 (#3) – CN-51 (#32) Checking Open/Short | | | | |
| 850 | 2 | (When mounting the RMCU) 60 seconds continuous, RMCU communication Data Error | ● | | |
| | (Results / Symptoms) 1. Control Function – RMCU operation failure (Checking list) 1. CN-125A (#3) – CN-51 (#22) Checking Open/Short 2. CN-125A (#11) – CN-51 (#32) Checking Open/Short | | | | |
| 861 | 2 | (When mounting the I/O Controller 2) 60 seconds continuous, I/O Controller 2 communication Data Error | ● | | |
| | (Results / Symptoms) 1. Control Function – I/O Controller 2 operation failure (Checking list) 1. CN-53 (#21) – CN-51 (#23) Checking Open/Short 2. CN-53 (#31) – CN-51 (#33) Checking Open/Short | | | | |

※ Some error codes are not applied to this machine.

G : General

C : Crawler Type

W : Wheel Type

| DTC | | Diagnostic Criteria | Application | | |
|--------|--|--|-------------|---|---|
| HCESPN | FMI | | G | C | W |
| 866 | 2 | (When mounting the AAVM) 60 seconds continuous, AAVM communication Data Error | ● | | |
| | (Results / Symptoms) 1. Control Function – AAVM operation failure (Checking list) 1. CN-401 (#86) – CN-51 (#22) Checking Open/Short 2. CN-401 (#87) – CN-51 (#32) Checking Open/Short | | | | |
| 867 | 2 | 60 seconds continuous, RDU communication Data Error | ● | | |
| | (Results / Symptoms) 1. Control Function – RDU operation failure (Checking list) 1. CN-376 (#10) – CN-51 (#22) Checking Open/Short 2. CN-376 (#18) – CN-51 (#32) Checking Open/Short | | | | |
| 868 | 2 | 60 seconds continuous, Switch Controller communication Data Error | ● | | |
| | (Results / Symptoms) 1. Control Function – Switch Controller operation failure (Checking list) 1. CN-56A (#7) – CN-51 (#22) Checking Open/Short 2. CN-56A (#6) – CN-51 (#32) Checking Open/Short | | | | |
| 869 | 2 | (When mounting the BKCU) 60 seconds continuous, BKCU communication Data Error | ● | | |
| | (Results / Symptoms) 1. Control Function – BKCU operation failure (Checking list) 1. CS-2B (#A) – CN-51 (#22) Checking Open/Short 2. CS-2B (#B) – CN-51 (#32) Checking Open/Short | | | | |

※ Some error codes are not applied to this machine.

G : General

C : Crawler Type

W : Wheel Type

4. ENGINE FAULT CODE

| Fault code J1939 SPN J1939 FMI | Name | Description |
|--------------------------------------|--------------------------------|--|
| 12D1 46 1 | Pneumatic supply pressure | Low air pressure signal from APS |
| 12D4 46 19 | Pneumatic supply pressure | CAN message timeout from APS |
| 2123 51 3 | Engine throttle valve position | Throttle Position Sensor 1, short circuit to +24 |
| 2122 51 4 | Engine throttle valve position | Throttle Position Sensor 1, short circuit to ground |
| 2121 51 7 | Engine throttle valve position | Throttle Position Sensor, not plausible |
| 1091 51 8 | Engine throttle valve position | Endpoints of throttle position sensor are out of range |
| 2138 51 9 | Engine throttle valve position | Throttle Position Sensor, correlation error |
| 16C9 91 2 | Accelerator pedal position | Auxiliary accelerator pedal is used due to other fault |
| 16C8 91 9 | Accelerator pedal position | Accelerator pedal faulty or error via can |
| D415 91 10 | Accelerator pedal position | Accelerator pedal not plausible, faulty |
| D414 91 19 | Accelerator pedal position | Accelerator pedal value out of range via CAN |
| 1100 94 0 | Engine fuel deliver pressure | Accumulator pressure is too high |
| 250A 98 2 | Engine oil level | Oil level sensor, faulty |
| 250D 98 3 | Engine oil level | Oil level sensor, short circuit to +24V |
| 250C 98 4 | Engine oil level | Oil level sensor, short circuit to ground |
| 1715 98 10 | Engine oil level | Oil level sensor stuck |

※ Some fault codes are not applied to this machine.

| Fault code J1939 SPN J1939 FMI | Name | Description |
|--------------------------------------|---------------------------------|--|
| 0524 100 1 | Engine oil pressure | Oil pressure sensor, pressure too low |
| 0521 100 2 | Engine oil pressure | Oil pressure sensor, faulty |
| 0523 100 3 | Engine oil pressure | Oil pressure sensor, short circuit to +24V |
| 0522 100 4 | Engine oil pressure | Oil pressure sensor, short circuit to ground |
| 1522 100 13 | Engine oil pressure | Oil pressure sensor, pressure not plausible |
| 1520 100 16 | Engine oil pressure | Oil pressure sensor, pressure above normal |
| 134F 100 17 | Engine oil pressure | Oil pressure sensor, pressure too low and engine protective action |
| 1521 100 18 | Engine oil pressure | Oil pressure sensor, pressure below normal |
| 0234 102 0 | Engine intake manifold pressure | Boost pressure higher than reference |
| 0299 102 1 | Engine intake manifold pressure | Boost pressure lower than reference |
| 0108 102 3 | Engine intake manifold pressure | Boost pressure sensor, short circuit to +24V |
| 0107 102 4 | Engine intake manifold pressure | Boost pressure sensor, short circuit to ground |
| 2262 102 7 | Engine intake manifold pressure | Boost pressure, too low |
| 1081 102 8 | Engine intake manifold pressure | Boost pressure sensor, faulty |
| 107C 102 9 | Engine intake manifold pressure | Boost pressure, not plausible |
| 006C 102 10 | Engine intake manifold pressure | Boost pressure sensor, faulty |

※ Some fault codes are not applied to this machine.

| Fault code J1939 SPN J1939 FMI | Name | Description |
|--------------------------------------|------------------------------------|--|
| 006B 102 15 | Engine intake manifold pressure | Boost pressure sensor and exhaust pressure sensor do not correlate |
| 1234 102 16 | Engine intake manifold pressure | Boost pressure above normal |
| 1299 102 18 | Engine intake manifold pressure | Boost pressure, lower than reference at part load |
| 1066 102 20 | Engine intake manifold pressure | Boost pressure, too high not plausible |
| 1067 102 21 | Engine intake manifold pressure | Boost pressure, too low not plausible |
| 1683 103 0 | Engine turbocharger speed | Turbine excessive overspeed |
| 2579 103 2 | Engine turbocharger speed | Turbine speed sensor, faulty |
| 2581 103 3 | Engine turbocharger speed | Turbine speed sensor, short circuit to +24V |
| 2580 103 4 | Engine turbocharger speed | Turbine speed sensor, short circuit to ground |
| 2578 103 5 | Engine turbocharger speed | Turbine speed sensor, open load |
| 150B 103 9 | Engine turbocharger speed | Turbine speed not plausible |
| 1506 103 20 | Engine turbocharger speed | Turbine speed sensor above model, not plausible |
| 1504 103 21 | Engine turbocharger speed | Turbine speed sensor below model, not plausible |
| 16EA 105 0 | Engine intake manifold temperature | Boost temp sensor excessive high |
| 16EB 105 1 | Engine intake manifold temperature | Boost temp sensor excessive low |
| 0096 105 2 | Engine intake manifold temperature | Boost temp sensor, faulty |

※ Some fault codes are not applied to this machine.

| Fault code J1939 SPN J1939 FMI | Name | Description |
|--------------------------------------|------------------------------------|--|
| 0098 105 3 | Engine intake manifold temperature | Boost temp sensor, short circuit to +24V |
| 0097 105 4 | Engine intake manifold temperature | Boost temp sensor, short circuit to ground |
| 16EE 105 9 | Engine intake manifold temperature | Boost temperature above ambient, not plausible |
| 16F3 105 15 | Engine intake manifold temperature | Boost temperature to high for longer period |
| 16C3 105 16 | Engine intake manifold temperature | Boost temperature above normal |
| 16EF 105 17 | Engine intake manifold temperature | Boost temperature below ambient, not plausible |
| 16F0 105 20 | Engine intake manifold temperature | Boost temperature to high, not plausible |
| 16F1 105 21 | Engine intake manifold temperature | Boost temperature to low, not plausible |
| 1422 107 1 | Engine air filter pressure | Air filter clogged |
| 1423 107 2 | Engine air filter pressure | Air filter control switch broken |
| 2226 108 2 | Barometric pressure | Ambient Pressure Sensor Error via CAN |
| 16DB 108 3 | Barometric pressure | Ambient Pressure Sensor, short circuit to +24V |
| 16DA 108 4 | Barometric pressure | Ambient Pressure Sensor, short circuit to ground |
| 106C 108 15 | Barometric pressure | Ambient Pressure Sensor and Exhaust Pressure Sensor do not correlate |
| 006D 108 16 | Barometric pressure | Ambient Pressure above normal |
| 1064 108 20 | Barometric pressure | Ambient Pressure too high, not plausible |

※ Some fault codes are not applied to this machine.

| Fault code J1939 SPN J1939 FMI | Name | Description |
|--------------------------------------|----------------------------|--|
| 1065 108 21 | Barometric pressure | Ambient Pressure too low, not plausible |
| 1133 110 0 | Engine coolant temperature | Engine temperature, excessive high |
| 1128 110 1 | Engine coolant temperature | Engine temperature too low |
| 1136 110 2 | Engine coolant temperature | Engine temp sensor fault |
| 0118 110 3 | Engine coolant temperature | Engine temp sensor, short circuit to +24V |
| 0117 110 4 | Engine coolant temperature | Engine temp sensor, short circuit to ground |
| 0115 110 8 | Engine coolant temperature | Engine temp sensor, stuck |
| 0116 110 9 | Engine coolant temperature | Engine temp sensor, faulty |
| 1135 110 10 | Engine coolant temperature | Engine temperature is not plausible |
| 1132 110 16 | Engine coolant temperature | Engine temperature, too high |
| 1130 110 17 | Engine coolant temperature | Engine temp sensor, temp below normal or VGT-temp above normal |
| 1131 110 18 | Engine coolant temperature | Engine temp sensor, temp above normal or VGT-temp below normal |
| 0217 110 20 | Engine coolant temperature | Engine Coolant Water Temperature Too High |
| 0128 110 21 | Engine coolant temperature | Coolant Temperature Below Thermostat Regulating Temperature |
| 2560 111 1 | Engine coolant level | Coolant level too low |
| 2556 111 3 | Engine coolant level | Coolant level sensor, short circuit to +24 |

※ Some fault codes are not applied to this machine.

| Fault code J1939 SPN J1939 FMI | Name | Description |
|--------------------------------------|----------------------------------|--|
| 2558 111 4 | Engine coolant level | Coolant level sensor, short circuit to ground |
| 107D 131 2 | Engine exhaust back pressure | Exhaust pressure sensor, not plausible |
| 0473 131 3 | Engine exhaust back pressure | Exhaust pressure sensor, short circuit to +24V |
| 0472 131 4 | Engine exhaust back pressure | Exhaust pressure sensor, short circuit to ground or open load |
| 106B 131 7 | Engine exhaust back pressure | Exhaust pressure sensor and boost pressure sensor do not correlate |
| 1078 131 8 | Engine exhaust back pressure | Exhaust pressure sensor, faulty |
| 16CC 131 9 | Engine exhaust back pressure | Exhaust pressure sensor, stuck |
| 106D 131 10 | Engine exhaust back pressure | Exhaust pressure sensor and ambient pressure sensor do not correlate |
| 1414 131 15 | Engine exhaust back pressure | Exhaust pressure, high exhaust pressure during normal fueling |
| 1413 131 16 | Engine exhaust back pressure | Exhaust pressure, high exhaust pressure during motoring, no fueling |
| 1415 131 18 | Engine exhaust back pressure | Exhaust pressure, low exhaust pressure during exhaust brake |
| 1068 131 20 | Engine exhaust back pressure | Exhaust pressure too high, not plausible |
| 106A 131 21 | Engine exhaust back pressure | Exhaust pressure too low, not plausible |
| 0103 132 0 | Engine intake air mass flow rate | Mass flow sensor, short circuit to +24V |
| 0102 132 1 | Engine intake air mass flow rate | Mass flow sensor, short circuit to ground or open load |
| 0101 132 2 | Engine intake air mass flow rate | Mass flow sensor, faulty |

※ Some fault codes are not applied to this machine.

| Fault code J1939 SPN J1939 FMI | Name | Description |
|--------------------------------------|--------------------------------------|---|
| 1187 132 3 | Engine intake air mass flow rate | Mass flow sensor, supply |
| 1189 132 4 | Engine intake air mass flow rate | Mass flow sensor, adaptation under low threshold |
| 1188 132 5 | Engine intake air mass flow rate | Mass flow sensor, adaptation over high threshold |
| 0100 132 7 | Engine intake air mass flow rate | Mass flow sensor, stuck |
| 0088 156 0 | Engine injector timing rail pressure | Fuel rail pressure is excessively above command |
| 0087 156 1 | Engine injector timing rail pressure | Fuel rail pressure is excessively below command |
| 0191 156 2 | Engine injector timing rail pressure | Fuel rail pressure sensor, faulty |
| 0193 156 3 | Engine injector timing rail pressure | Fuel rail pressure sensor, short circuit to +24V or open load |
| 0192 156 4 | Engine injector timing rail pressure | Fuel rail pressure sensor, short circuit to ground |
| 0190 156 8 | Engine injector timing rail pressure | Fuel rail pressure sensor, stuck |
| 1090 156 9 | Engine injector timing rail pressure | Fuel rail pressure is lagging |
| 1087 156 18 | Engine injector timing rail pressure | Fuel rail pressure is too low during cranking |
| 1060 167 2 | Charging system potential | Alternator actuator, faulty |
| 1063 167 3 | Charging system potential | Alternator actuator, short circuit to +24V |
| 1062 167 4 | Charging system potential | Alternator actuator, short circuit to ground |
| 1061 167 5 | Charging system potential | Alternator actuator, open load |

※ Some fault codes are not applied to this machine.

| Fault code J1939 SPN J1939 FMI | Name | Description |
|--------------------------------------|---------------------------|---|
| 063A 167 9 | Charging system potential | Alternator 1, signal not plausible |
| 160B 167 10 | Charging system potential | Alternator 2, signal not plausible |
| 1565 168 0 | Battery potential | Battery voltage above 47 V for 1 s |
| 1564 168 1 | Battery potential | Battery voltage below 9 V for 0.5 s |
| 1507 168 4 | Battery potential | Battery voltage 1 for engine control unit is low |
| 1509 168 5 | Battery potential | Battery voltage 2 for engine control unit is low |
| 2064 168 15 | Battery potential | Battery voltage too high for SCR main unit |
| 0563 168 16 | Battery potential | Battery voltage above 32 V |
| 2063 168 17 | Battery potential | Battery voltage too low for SCR main unit |
| 0562 168 18 | Battery potential | Battery voltage below 21 V |
| 1074 171 0 | Ambient air temperature | Ambient temperature sensors correlation error |
| 1271 171 1 | Ambient air temperature | Ambient temperature low or boost temperature high |
| 11B0 171 2 | Ambient air temperature | Ambient temperature sensor, faulty |
| 1073 171 3 | Ambient air temperature | Ambient temperature sensor error via CAN |
| 1075 171 4 | Ambient air temperature | Ambient temperature sensor error via CAN |
| 1077 171 7 | Ambient air temperature | Ambient temperature sensor stuck |

※ Some fault codes are not applied to this machine.

| Fault code J1939 SPN J1939 FMI | Name | Description |
|--------------------------------------|-------------------------------|---|
| D104 171 9 | Ambient air temperature | CAN message AMBIENT CONDITION from coordinator timeout |
| 1076 171 15 | Ambient air temperature | Ambient temperature sensors correlation error |
| 1270 171 16 | Ambient air temperature | Ambient temperature high or boost temperature low |
| 1071 171 17 | Ambient air temperature | Ambient temperature sensors correlation error |
| 1072 171 18 | Ambient air temperature | Ambient temperature sensors correlation error |
| 1070 171 19 | Ambient air temperature | Ambient temperature sensor signal defect |
| 0070 171 20 | Ambient air temperature | Temperature sensor before compressor low or ambient temperature sensor high |
| 0071 171 21 | Ambient air temperature | Temperature sensor before compressor high or ambient temperature sensor low |
| 0111 172 2 | Engine air intake temperature | Air inlet temp sensor, faulty |
| 0113 172 3 | Engine air intake temperature | Air inlet temp sensor, short circuit to +24V |
| 0112 172 4 | Engine air intake temperature | Air inlet temp sensor, short circuit to ground |
| 0114 172 7 | Engine air intake temperature | Air inlet temp sensor, stuck |
| 0198 175 3 | Engine oil temperature | Oil temp sensor, short circuit to +24V |
| 0197 175 4 | Engine oil temperature | Oil temp sensor, short circuit to ground |
| 0195 175 11 | Engine oil temperature | Oil temp sensor, faulty |
| 16C2 188 14 | Engine speed at idle | Idle due to other fault |

※ Some fault codes are not applied to this machine.

| Fault code J1939 SPN J1939 FMI | Name | Description |
|--------------------------------------|-------------------------------------|---|
| 1205 190 0 | Engine speed | Severe overspeed has occurred |
| 1201 190 10 | Engine speed | Overspeed protection, fast over speed |
| 1321 190 15 | Engine speed | Engine speed has been above the limit |
| 1202 190 16 | Engine speed | Overspeed protection, over speed |
| 0219 190 20 | Engine speed | Engine overspeed, value to high |
| C10F 234 2 | Software identification | The EMS and EEC control units are incompatible |
| D10B 234 19 | Software identification | Wrong CAN version transmitted by COO |
| 16C1 532 14 | Engine speed at high idle | Increased idle due to other fault |
| D109 558 2 | Accelerator pedal - low idle switch | Low idle switch error state from coordinator |
| D107 559 2 | Accelerator pedal kickdown switch | Kickdown signal defect via CAN |
| 1550 559 9 | Accelerator pedal kickdown switch | Accelerator pedal kickdown CAN message, faulty |
| D418 559 10 | Accelerator pedal kickdown switch | Accelerator pedal/kick down switch, EMS and coordinator do not agree |
| D105 597 2 | Brake switch | Brake pedal signal defect via CAN |
| D106 598 2 | Clutch switch | Clutch pedal signal defect via CAN |
| 0811 598 7 | Clutch switch | Excessive clutch slip |
| D10D 598 19 | Clutch switch | CAN-signal or engine shut-down command from OPC for automatic clutch failure, timeout |

※ Some fault codes are not applied to this machine.

| Fault code J1939 SPN J1939 FMI | Name | Description |
|--------------------------------------|------------------------------|--|
| 1214 636 1 | Engine position sensor | Camshaft position sensor, faulty |
| 0344 636 2 | Engine position sensor | Camshaft position sensor, intermittent fault |
| 0343 636 3 | Engine position sensor | Camshaft position sensor, short circuit to +24V |
| 0342 636 4 | Engine position sensor | Camshaft position sensor, short circuit to ground |
| 0340 636 5 | Engine position sensor | Camshaft position sensor, open circuit |
| 0016 636 7 | Engine position sensor | Engine speed detected by flywheel sensor, but no signal from camshaft sensor |
| 0341 636 8 | Engine position sensor | Camshaft Pulse Pattern, Gap or Sync Error or other fault |
| 16E7 641 2 | Engine turbocharger actuator | VGT internal temperature sensor stuck |
| 1686 641 4 | Engine turbocharger actuator | VGT voltage supply open load |
| 16B5 641 5 | Engine turbocharger actuator | VGT internal temperature sensor open circuit |
| 168B 641 7 | Engine turbocharger actuator | VGT motion limited or restricted |
| 168E 641 8 | Engine turbocharger actuator | VGT reference or position not found |
| 1134 641 9 | Engine turbocharger actuator | VGT temperature sensor value not plausible |
| 168C 641 10 | Engine turbocharger actuator | VGT motion error, span too large |
| 1689 641 11 | Engine turbocharger actuator | VGT actuator faulty |
| 1693 641 12 | Engine turbocharger actuator | VGT internal fault |

※ Some fault codes are not applied to this machine.

| Fault code J1939 SPN J1939 FMI | Name | Description |
|--------------------------------------|------------------------------|--|
| 16DF 641 13 | Engine turbocharger actuator | VGT actuator installation procedure was not completed |
| 1685 641 15 | Engine turbocharger actuator | VGT error |
| 1684 641 16 | Engine turbocharger actuator | VGT temperature too high |
| 1690 641 19 | Engine turbocharger actuator | VGT timeout on CAN |
| D101 645 19 | Engine tachometer | CAN message TCO1 from tachograph timeout |
| 11A1 651 1 | Engine injector cylinder 1 | Two or more injectors with the same trim code, injector cyl. 1 |
| 1178 651 2 | Engine injector cylinder 1 | Injector trim code, checksum error injector cyl. 1 |
| 0261 651 4 | Engine injector cylinder 1 | Injector 1 cable short circuit to ground |
| 0201 651 5 | Engine injector cylinder 1 | Injector cyl. 1 cable/injector open load |
| 115F 651 6 | Engine injector cylinder 1 | Injector cyl. 1 cable/injector short circuit |
| 1150 651 7 | Engine injector cylinder 1 | Injection error, physical cylinder 1 |
| 118F 651 8 | Engine injector cylinder 1 | Injector cyl. 1, over or under fueling |
| 12C0 651 10 | Engine injector cylinder 1 | Fault with sensors/actuators for the particulate filter |
| 1199 651 13 | Engine injector cylinder 1 | Injector trim code version error, injector cyl. 1 |
| 11E0 651 15 | Engine injector cylinder 1 | Cylinder 1 torque error |
| 11D0 651 16 | Engine injector cylinder 1 | Cylinder 1 injector fault, high torque |

※ Some fault codes are not applied to this machine.

| Fault code J1939 SPN J1939 FMI | Name | Description |
|--------------------------------------|----------------------------|--|
| 11D8 651 18 | Engine injector cylinder 1 | Cylinder 1 injector fault, low torque |
| 0263 651 20 | Engine injector cylinder 1 | Cylinder 1 balancing min or max |
| 11E8 651 21 | Engine injector cylinder 1 | Cylinder balancing, not plausible |
| 11A2 652 1 | Engine injector cylinder 2 | Two or more injectors with the same trim code, injector cyl. 2 |
| 1179 652 2 | Engine injector cylinder 2 | Injector trim code, checksum error injector cyl. 2 |
| 0264 652 4 | Engine injector cylinder 2 | Injector 2 cable short circuit to ground |
| 0202 652 5 | Engine injector cylinder 2 | Injector cyl. 2 cable/injector open load |
| 1161 652 6 | Engine injector cylinder 2 | Injector cyl. 2 cable/injector short circuit |
| 1151 652 7 | Engine injector cylinder 2 | Injection error, physical cylinder 2 |
| 1190 652 8 | Engine injector cylinder 2 | Injector cyl. 2, over or under fueling |
| 12C1 652 10 | Engine injector cylinder 2 | Fault with sensors/actuators for the particulate filter |
| 119A 652 13 | Engine injector cylinder 2 | Injector trim code version error, injector cyl. 2 |
| 11E1 652 15 | Engine injector cylinder 2 | Cylinder 2 torque error |
| 11D1 652 16 | Engine injector cylinder 2 | Cylinder 2 injector fault, high torque |
| 11D9 652 18 | Engine injector cylinder 2 | Cylinder 2 injector fault, low torque |
| 0266 652 20 | Engine injector cylinder 2 | Cylinder 2 balancing min or max |

※ Some fault codes are not applied to this machine.

| Fault code J1939 SPN J1939 FMI | Name | Description |
|--------------------------------------|----------------------------|--|
| 11A3 653 1 | Engine injector cylinder 3 | Two or more injectors with the same trim code, injector cyl. 3 |
| 117A 653 2 | Engine injector cylinder 3 | Injector trim code, checksum error injector cyl. 3 |
| 0267 653 4 | Engine injector cylinder 3 | Injector 3 cable short circuit to ground |
| 0203 653 5 | Engine injector cylinder 3 | Injector cyl. 3 cable/injector open load |
| 1164 653 6 | Engine injector cylinder 3 | Injector cyl. 3 cable/injector short circuit |
| 1152 653 7 | Engine injector cylinder 3 | Injection error, physical cylinder 3 |
| 1191 653 8 | Engine injector cylinder 3 | Injector cyl. 3, over or under fueling |
| 12C2 653 10 | Engine injector cylinder 3 | Fault with sensors/actuators for the particulate filter |
| 119B 653 13 | Engine injector cylinder 3 | Injector trim code version error, injector cyl. 3 |
| 11E2 653 15 | Engine injector cylinder 3 | Cylinder 3 torque error |
| 11D2 653 16 | Engine injector cylinder 3 | Cylinder 3 injector fault, high torque |
| 11DA 653 18 | Engine injector cylinder 3 | Cylinder 3 injector fault, low torque |
| 0269 653 20 | Engine injector cylinder 3 | Cylinder 3 balancing min or max |
| 11A4 654 1 | Engine injector cylinder 4 | Two or more injectors with the same trim code, injector cyl. 4 |
| 117B 654 2 | Engine injector cylinder 4 | Injector trim code, checksum error injector cyl. 4 |
| 0270 654 4 | Engine injector cylinder 4 | Injector 4 cable short circuit to ground |

※ Some fault codes are not applied to this machine.

| Fault code J1939 SPN J1939 FMI | Name | Description |
|--------------------------------------|----------------------------|--|
| 0204 654 5 | Engine injector cylinder 4 | Injector cyl. 4 cable/injector open load |
| 1167 654 6 | Engine injector cylinder 4 | Injector cyl. 4 cable/injector short circuit |
| 1153 654 7 | Engine injector cylinder 4 | Injection error, physical cylinder 4 |
| 1192 654 8 | Engine injector cylinder 4 | Injector cyl. 4, over or under fueling |
| 12C3 654 10 | Engine injector cylinder 4 | Fault with sensors/actuators for the particulate filter |
| 119C 654 13 | Engine injector cylinder 4 | Injector trim code version error, injector cyl. 4 |
| 11E3 654 15 | Engine injector cylinder 4 | Cylinder 4 torque error |
| 11D3 654 16 | Engine injector cylinder 4 | Cylinder 4 injector fault, high torque |
| 11DB 654 18 | Engine injector cylinder 4 | Cylinder 4 injector fault, low torque |
| 0272 654 20 | Engine injector cylinder 4 | Cylinder 4 balancing min or max |
| 11A5 655 1 | Engine injector cylinder 5 | Two or more injectors with the same trim code, injector cyl. 5 |
| 117C 655 2 | Engine injector cylinder 5 | Injector trim code, checksum error injector cyl. 5 |
| 0273 655 4 | Engine injector cylinder 5 | Injector 5 cable short circuit to ground |
| 0205 655 5 | Engine injector cylinder 5 | Injector cyl. 5 cable/injector open load |
| 116E 655 6 | Engine injector cylinder 5 | Injector cyl. 5 cable/injector short circuit |
| 1154 655 7 | Engine injector cylinder 5 | Injection error, physical cylinder 5 |

※ Some fault codes are not applied to this machine.

| Fault code J1939 SPN J1939 FMI | Name | Description |
|--------------------------------------|----------------------------|--|
| 1193 655 8 | Engine injector cylinder 5 | Injector cyl. 5, over or under fueling |
| 12C4 655 10 | Engine injector cylinder 5 | Fault with sensors/actuators for the particulate filter |
| 119D 655 13 | Engine injector cylinder 5 | Injector trim code version error, injector cyl. 5 |
| 11E4 655 15 | Engine injector cylinder 5 | Cylinder 5 torque error |
| 11D4 655 16 | Engine injector cylinder 5 | Cylinder 5 injector fault, high torque |
| 11DC 655 18 | Engine injector cylinder 5 | Cylinder 5 injector fault, low torque |
| 0275 655 20 | Engine injector cylinder 5 | Cylinder 5 balancing min or max |
| 11A6 656 1 | Engine injector cylinder 6 | Two or more injectors with the same trim code, injector cyl. 6 |
| 117D 656 2 | Engine injector cylinder 6 | Injector trim code, checksum error injector cyl. 6 |
| 0206 656 5 | Engine injector cylinder 6 | Injector cyl. 6 cable/injector open load |
| 1171 656 6 | Engine injector cylinder 6 | Injector cyl. 6 cable/injector short circuit |
| 1155 656 7 | Engine injector cylinder 6 | Injection error, physical cylinder 6 |
| 1194 656 8 | Engine injector cylinder 6 | Injector cyl. 6, over or under fueling |
| 119E 656 13 | Engine injector cylinder 6 | Injector trim code version error, injector cyl. 6 |
| 11E5 656 15 | Engine injector cylinder 6 | Cylinder 6 torque error |
| 11D5 656 16 | Engine injector cylinder 6 | Cylinder 6 injector fault, high torque |

※ Some fault codes are not applied to this machine.

| Fault code J1939 SPN J1939 FMI | Name | Description |
|--------------------------------------|----------------------------|--|
| 11DD 656 18 | Engine injector cylinder 6 | Cylinder 6 injector fault, low torque |
| 0278 656 20 | Engine injector cylinder 6 | Cylinder 6 balancing min or max |
| 11A7 657 1 | Engine injector cylinder 7 | Two or more injectors with the same trim code, injector cyl. 7 |
| 117E 657 2 | Engine injector cylinder 7 | Injector trim code, checksum error injector cyl. 7 |
| 0207 657 5 | Engine injector cylinder 7 | Injector cyl. 7 cable/injector open load |
| 1174 657 6 | Engine injector cylinder 7 | Injector cyl. 7 cable/injector short circuit |
| 1156 657 7 | Engine injector cylinder 7 | Injection error, physical cylinder 7 |
| 1195 657 8 | Engine injector cylinder 7 | Injector cyl. 7, over or under fueling |
| 119F 657 13 | Engine injector cylinder 7 | Injector trim code version error, injector cyl. 7 |
| 11E6 657 15 | Engine injector cylinder 7 | Cylinder 7 torque error |
| 11D6 657 16 | Engine injector cylinder 7 | Cylinder 7 injector fault, high torque |
| 11DE 657 18 | Engine injector cylinder 7 | Cylinder 7 injector fault, low torque |
| 0281 657 20 | Engine injector cylinder 7 | Cylinder 7 balancing min or max |
| 11A8 658 1 | Engine injector cylinder 8 | Two or more injectors with the same trim code, injector cyl. 8 |
| 117F 658 2 | Engine injector cylinder 8 | Injector trim code, checksum error injector cyl. 8 |
| 0208 658 5 | Engine injector cylinder 8 | Injector cyl. 8 cable/injector open load |

※ Some fault codes are not applied to this machine.

| Fault code J1939 SPN J1939 FMI | Name | Description |
|--------------------------------------|----------------------------|---|
| 1177 658 6 | Engine injector cylinder 8 | Injector cyl. 8 cable/injector short circuit |
| 1157 658 7 | Engine injector cylinder 8 | Injection error, physical cylinder 8 |
| 1196 658 8 | Engine injector cylinder 8 | Injector cyl. 8, over or under fueling |
| 11A0 658 13 | Engine injector cylinder 8 | Injector trim code version error, injector cyl. 8 |
| 11E7 658 15 | Engine injector cylinder 8 | Cylinder 8 torque error |
| 11D7 658 16 | Engine injector cylinder 8 | Cylinder 8 injector fault, high torque |
| 11DF 658 18 | Engine injector cylinder 8 | Cylinder 8 injector fault, low torque |
| 0284 658 20 | Engine injector cylinder 8 | Cylinder 8 balancing min or max |
| 160D 677 0 | Engine starter motor relay | Unintentional starter activation while moving or idling |
| 160C 677 2 | Engine starter motor relay | Starter actuator, faulty |
| 1645 677 3 | Engine starter motor relay | Starter actuator, short circuit to +24V |
| 1646 677 4 | Engine starter motor relay | Starter actuator, short circuit to ground |
| 0512 677 5 | Engine starter motor relay | Starter actuator, open load |
| 1670 677 7 | Engine starter motor relay | Starter actuator, blind start |
| D108 677 19 | Engine starter motor relay | Starter motor demand defect via CAN |
| 1319 723 2 | Engine speed | Engine position sensor 2, faulty |

※ Some fault codes are not applied to this machine.

| Fault code J1939 SPN J1939 FMI | Name | Description |
|--------------------------------------|--|--|
| 1312 723 4 | Engine speed | Engine position sensor 2, too weak signal |
| 1212 723 7 | Engine speed | Engine position sensor 2, faulty |
| 1330 723 8 | Engine speed | Engine position sensor 2, Gap Puls or Sync error |
| 1318 723 9 | Engine speed | Engine position sensor 2, Time out |
| 1311 723 10 | Engine speed | Engine position sensor 2, position diff |
| 1317 723 14 | Engine speed | Engine position sensor 2 error torque limit |
| 16C6 974 0 | Remote accelerator pedal position | Signal level from redundant gas pedal above high limit |
| 16C5 974 1 | Remote accelerator pedal position | Signal level from redundant gas pedal below low limit |
| 1602 986 2 | Requested % fan speed | Fan actuator, faulty |
| 0692 986 3 | Requested % fan speed | Fan actuator, short circuit to +24V |
| 0691 986 4 | Requested % fan speed | Fan actuator, short circuit high to ground |
| 0480 986 5 | Requested % fan speed | Fan actuator, open load |
| 1603 986 7 | Requested % fan speed | Fan coupling unit, bad performance |
| 12D3 1086 2 | Parking and/or trailer pressure | Electrical fault on the parking brake pressure sensor |
| 16C0 1108 14 | Engine protection system timer override | Overridden due to other fault |
| 16BF 1110 14 | Engine protection system has shutdown engine | Engine Stop due to other fault |

※ Some fault codes are not applied to this machine.

| Fault code J1939 SPN J1939 FMI | Name | Description |
|--------------------------------------|---|---|
| 0094 1239 7 | Engine fuel leakage | Fuel Rail pressure, small volume leak |
| 0300 1322 7 | Engine misfire for multiple cylinders | Random/Multiple Cylinder Misfire Detected |
| 0301 1323 7 | Engine misfire cylinder 1 | Cylinder 1 Misfire Detected |
| 0302 1324 7 | Engine misfire cylinder 2 | Cylinder 2 Misfire Detected |
| 0303 1325 7 | Engine misfire cylinder 3 | Cylinder 3 Misfire Detected |
| 0304 1326 7 | Engine misfire cylinder 4 | Cylinder 4 Misfire Detected |
| 0305 1327 7 | Engine misfire cylinder 5 | Cylinder 5 Misfire Detected |
| 1183 1442 2 | Engine fuel valve position | Inlet metering valve 1, faulty |
| 1184 1442 3 | Engine fuel valve position | Inlet metering valve 1, short circuit to +24V |
| 1182 1442 5 | Engine fuel valve position | Inlet metering valve 1, short circuit to ground |
| 11B8 1442 7 | Engine fuel valve position | Inlet metering valve 1, stuck |
| 11B1 1442 8 | Engine fuel valve position | Inlet metering valve 1, plausible leakage |
| 118E 1442 10 | Engine fuel valve position | Inlet metering valve 1, calculated resistance error |
| 1080 1443 1 | Engine fuel valve position | Mechanical dump valve, opened |
| 118B 1443 6 | Engine fuel valve position | Mechanical dump valve, tripped |
| 1605 1483 2 | Source address of engine control device | EMS internal error |

※ Some fault codes are not applied to this machine.

| Fault code J1939 SPN J1939 FMI | Name | Description |
|--------------------------------------|---|--|
| 1606 1483 2 | Source address of engine control device | EMS Memory Error |
| 1610 1483 2 | Source address of engine control device | EMS Memory Error |
| 1607 1483 8 | Source address of engine control device | EMS Memory or TPU Error |
| 160F 1483 8 | Source address of engine control device | EMS memory or TPU error |
| 16D7 1483 9 | Source address of engine control device | Camshaft TPU Supervision Error |
| 160A 1483 11 | Source address of engine control device | Software Watchdog Reset |
| 1604 1483 12 | Source address of engine control device | Hardware watchdog error |
| D100 1484 9 | Other control are reporting faults affecting the engine | CAN message DLN1 from coordinator timeout |
| D102 1484 10 | Other control are reporting faults affecting the engine | CAN message CRUISE CONTROL/ VEHICLE SPEED from coordinator timeout |
| D113 1484 16 | Other control are reporting faults affecting the engine | CAN message from EMSX, invalid data |
| D112 1484 18 | Other control are reporting faults affecting the engine | CAN message from EMSX, invalid data |
| D103 1484 19 | Other control are reporting faults affecting the engine | CAN message DLN6 from coordinator timeout |
| D111 1484 20 | Other control are reporting faults affecting the engine | CAN message timeout from EMSX |
| D110 1484 21 | Other control are reporting faults affecting the engine | CAN message timeout from EMSX |
| 20EA 1485 16 | ECM main relay | SCR main unit, power switched off too early |
| 20EB 1485 18 | ECM main relay | SCR main unit, power switched off too late |

※ Some fault codes are not applied to this machine.

| Fault code J1939 SPN J1939 FMI | Name | Description |
|--------------------------------------|--|--|
| 16BE 1569 14 | Engine protection torque derate | Torque reduction due to other fault |
| 16F9 1639 3 | Fan speed | Fan speed sensor, short circuit to +24V |
| 0526 1639 4 | Fan speed | Fan speed sensor supply too low |
| 0528 1639 8 | Fan speed | Fan speed sensor circuit no signal |
| D10F 1675 2 | Engine starter mode | Immobiliser - EMS and EMSX |
| C426 1675 9 | Engine starter mode | Invalid Data Received From Vehicle Control Module |
| D10A 1675 12 | Engine starter mode | Immobiliser error |
| C326 1675 13 | Engine starter mode | Software Incompatibility With Vehicle Immobilizer Control Module |
| C167 1675 19 | Engine starter mode | Lost Communication With Vehicle Immobilizer Control Module |
| 1704 1761 1 | After treatment diesel exhaust fluid level | Reductant tank, empty |
| 203C 1761 2 | After treatment diesel exhaust fluid level | Reductant tank level sensor, short circuit to ground |
| 203A 1761 3 | After treatment diesel exhaust fluid level | Reductant tank level sensor, short circuit to +24V |
| 203D 1761 5 | After treatment diesel exhaust fluid level | Reductant tank level sensor, open circuit |
| 203F 1761 18 | After treatment diesel exhaust fluid level | Reductant tank, low level |
| 1600 2609 2 | Cab A/C outlet pressure | AC compressor actuator, faulty |
| 2521 2609 3 | Cab A/C outlet pressure | AC compressor actuator, short circuit to +24V |

※ Some fault codes are not applied to this machine.

| Fault code J1939 SPN J1939 FMI | Name | Description |
|--------------------------------------|--------------------------|---|
| 2520 2609 4 | Cab A/C outlet pressure | AC compressor actuator, short circuit to ground |
| 2519 2609 5 | Cab A/C outlet pressure | AC compressor actuator, open load |
| 042F 2791 2 | Engine EGR valve control | EGR actuator, control error |
| 0490 2791 3 | Engine EGR valve control | EGR actuator, short circuit to +24V |
| 0489 2791 4 | Engine EGR valve control | EGR actuator, short circuit to ground |
| 1400 2791 5 | Engine EGR valve control | EGR actuator, stuck open |
| 0488 2791 7 | Engine EGR valve control | EGR actuator, stuck close |
| 1424 2791 8 | Engine EGR valve control | The EGR valve is responding too slow |
| 2BAB 2791 10 | Engine EGR valve control | NOx Exceedence - Incorrect EGR Flow |
| 0400 2791 11 | Engine EGR valve control | EGR system faulty |
| 2BAC 2791 16 | Engine EGR valve control | NOx Exceedence - Deactivation of EGR |
| 0402 2791 20 | Engine EGR valve control | EGR higher than desired |
| 0401 2791 21 | Engine EGR valve control | EGR lower than desired |
| 115D 2797 2 | Engine injector group 1 | Injector group A, short circuit to other bank |
| 115C 2797 3 | Engine injector group 1 | Injector group A, short circuit to +24V |
| 115B 2797 4 | Engine injector group 1 | Injector group A, short circuit to ground |

※ Some fault codes are not applied to this machine.

| Fault code J1939 SPN J1939 FMI | Name | Description |
|--------------------------------------|---|--|
| 1692 2797 5 | Engine injector group 1 | Injector drive voltage, faulty |
| 115A 2797 8 | Engine injector group 1 | Injector group A, injection error |
| 116D 2798 2 | Engine injector group 2 | Injector group B, short circuit to other bank |
| 116C 2798 3 | Engine injector group 2 | Injector group B, short circuit +24V |
| 116B 2798 4 | Engine injector group 2 | Injector group B, short circuit ground |
| 116A 2798 8 | Engine injector group 2 | Injection error, group B |
| 1608 2858 13 | Machine data config. 1 | EMS, Default EOL Data in E2 |
| 1609 2859 13 | Machine data config. 2 | EMS, Default Barcoding Data in E2 |
| 1697 2860 13 | Machine data config. 3 | EMS internal software error |
| 1613 2861 13 | Machine data config. 4 | EMS Configuration for Automatic Clutch Faulty |
| 9999 2862 13 | Machine data config. 5 | Internal software error |
| 1038 3031 0 | After treatment diesel exhaust fluid tank temperature | SCR main unit, high temperature low limit exceedence |
| 2215 3216 4 | After treatment - intake Nox | NOx sensor upstream, internal fault or open circuit |
| 2213 3216 5 | After treatment - intake Nox | NOx sensor upstream, open circuit |
| 2214 3216 7 | After treatment - intake Nox | NOx sensor upstream, internal fault |
| 100B 3216 8 | After treatment - intake Nox | NOx sensor upstream of catalytic converter |

※ Some fault codes are not applied to this machine.

| Fault code J1939 SPN J1939 FMI | Name | Description |
|--------------------------------------|------------------------------|---|
| 100E 3216 9 | After treatment - intake Nox | NOx sensor upstream of catalytic converter |
| 16CF 3216 10 | After treatment - intake Nox | NOx sensor upstream, stuck |
| 16F4 3216 17 | After treatment - intake Nox | NOx sensor upstream, low signal |
| 16D8 3216 18 | After treatment - intake Nox | NOx sensor upstream, too low value |
| 12CA 3216 19 | After treatment - intake Nox | NOx sensor upstream error via CAN |
| 16FA 3216 20 | After treatment - intake Nox | NOx sensor upstream, not plausible |
| 2202 3226 4 | After treatment - outlet Nox | NOx sensor downstream, internal fault or open circuit |
| 2200 3226 5 | After treatment - outlet Nox | NOx sensor downstream, open circuit |
| 2201 3226 7 | After treatment - outlet Nox | NOx sensor downstream, internal fault |
| 12C9 3226 8 | After treatment - outlet Nox | NOx sensor downstream error via CAN |
| 100F 3226 9 | After treatment - outlet Nox | NOx sensor downstream of the SCR catalytic converter |
| 16CE 3226 10 | After treatment - outlet Nox | NOx sensor downstream, stuck |
| 16F2 3226 17 | After treatment - outlet Nox | NOx sensor downstream, low signal |
| 16D9 3226 18 | After treatment - outlet Nox | NOx sensor downstream, too low value |
| 100A 3226 19 | After treatment - outlet Nox | NOx sensor downstream of the catalytic converter |
| 16FB 3226 20 | After treatment - outlet Nox | NOx sensor downstream, not plausible |

※ Some fault codes are not applied to this machine.

| Fault code J1939 SPN J1939 FMI | Name | Description |
|--------------------------------------|---|---|
| 0426 3241 2 | After treatment - exhaust gas temperature | Upstream catalyst temperature sensor not plausible. |
| 104D 3241 3 | After treatment - exhaust gas temperature | Upstream catalyst temperature sensor not plausible, too high |
| 0427 3241 4 | After treatment - exhaust gas temperature | Upstream catalyst temperature sensor not plausible, short circuit |
| 0425 3241 5 | After treatment - exhaust gas temperature | Upstream catalyst temperature sensor not plausible, open circuit |
| 104F 3241 8 | After treatment - exhaust gas temperature | Upstream catalyst temperature sensor not plausible, too high |
| 16CD 3241 10 | After treatment - exhaust gas temperature | Upstream catalyst temperature sensor not plausible. |
| 20ED 3241 16 | After treatment - exhaust gas temperature | Upstream catalyst temperature too high |
| 104E 3241 18 | After treatment - exhaust gas temperature | Upstream catalyst temperature sensor not plausible, too low |
| 16FF 3241 19 | After treatment - exhaust gas temperature | CAN Error from Exhaust Temperature Sensors |
| 1803 3242 0 | After treatment - DPF intake gas temp. | Upstream DPF temperature sensor, too high |
| 16FC 3242 7 | After treatment - DPF intake gas temp. | Upstream DPF temperature sensor, not plausible |
| 2080 3242 9 | After treatment - DPF intake gas temp. | Upstream DPF temperature sensor, not plausible |
| 200F 3242 10 | After treatment - DPF intake gas temp. | Upstream DPF temperature too high during normal condition |
| 200E 3242 16 | After treatment - DPF intake gas temp. | Upstream DPF temperature too high during regeneration |
| 12CF 3245 19 | After treatment - exhaust gas temperature | Auxiliary Temperature Sensor Error on CAN |
| 12CB 3246 2 | After treatment - DPF outlet gas temp. | Downstream DPF temperature sensor error |

※ Some fault codes are not applied to this machine.

| Fault code J1939 SPN J1939 FMI | Name | Description |
|--------------------------------------|---|---|
| 042C 3246 3 | After treatment - DPF outlet gas temp. | Exhaust temperature sensor after SCR catalytic converter, short circuit |
| 042D 3246 4 | After treatment - DPF outlet gas temp. | Exhaust temperature sensor after SCR catalytic converter, open circuit |
| 242B 3246 9 | After treatment - DPF outlet gas temp. | Downstream exhaust temperature sensor, not plausible |
| 200D 3246 15 | After treatment - DPF outlet gas temp. | Downstream DPF temperature too high during normal condition |
| 200C 3246 16 | After treatment - DPF outlet gas temp. | Downstream DPF temperature too high during regeneration |
| 16E3 3251 2 | After treatment - DPF differential pressure | Particulate filter is missing |
| 16D6 3251 7 | After treatment - DPF differential pressure | Differential pressure sensor over particulate filter, faulty |
| 16E4 3251 7 | After treatment - DPF differential pressure | Particulate filter is damaged or cracked |
| 12D2 3251 8 | After treatment - DPF differential pressure | Differential pressure sensor not plausible |
| 16D5 3251 9 | After treatment - DPF differential pressure | Differential pressure sensor over particulate filter, not plausible |
| 16ED 3340 1 | Engine CAC intake pressure | Intercooler temperature, too low |
| 1111 3340 3 | Engine CAC intake pressure | Intercooler pressure sensor, short circuit to ground |
| 1112 3340 4 | Engine CAC intake pressure | Intercooler pressure sensor, short circuit to +24V |
| 1079 3340 7 | Engine CAC intake pressure | Intercooler pressure sensor, stuck |
| 107E 3340 9 | Engine CAC intake pressure | Intercooler pressure sensor, not plausible |
| 107F 3340 10 | Engine CAC intake pressure | Intercooler pressure sensor, not plausible |

※ Some fault codes are not applied to this machine.

| Fault code J1939 SPN J1939 FMI | Name | Description |
|--------------------------------------|---|---|
| 106F 3340 15 | Engine CAC intake pressure | Intercooler pressure, above normal |
| 106E 3340 16 | Engine CAC intake pressure | Intercooler pressure, above normal |
| 107A 3340 20 | Engine CAC intake pressure | Intercooler pressure too high |
| 107B 3340 21 | Engine CAC intake pressure | Intercooler pressure too low |
| 16DD 3360 0 | After treatment - Diesel exhaust fluid controller | SCR system adaptation have reached max values |
| 16DE 3360 1 | After treatment - Diesel exhaust fluid controller | SCR system adaptation have reached min values |
| 12C7 3360 2 | After treatment - Diesel exhaust fluid controller | EEC3 System has demanded "SCR Hazardous major functional failure" actions |
| 20A3 3360 3 | After treatment - Diesel exhaust fluid controller | SCR main unit, ventilation valve test, short to battery |
| 1033 3360 4 | After treatment - Diesel exhaust fluid controller | SCR main unit, internal supply voltage low |
| 20A0 3360 5 | After treatment - Diesel exhaust fluid controller | SCR main unit, ventilation valve test, open load |
| 1047 3360 6 | After treatment - Diesel exhaust fluid controller | SCR main unit, system voltage error |
| 1022 3360 7 | After treatment - Diesel exhaust fluid controller | SCR main unit, ignition switch plausible error |
| 12C6 3360 9 | After treatment - Diesel exhaust fluid controller | EEC3 has demanded "SCR Major functional failure reductant dosing stopped" actions |
| 12C8 3360 10 | After treatment - Diesel exhaust fluid controller | EEC3 System has demanded "SCR minor functional failure" actions |
| 16AA 3360 12 | After treatment - Diesel exhaust fluid controller | SCR main unit, error |
| 1032 3360 16 | After treatment - Diesel exhaust fluid controller | SCR main unit, internal supply voltage high |

※ Some fault codes are not applied to this machine.

| Fault code J1939 SPN J1939 FMI | Name | Description |
|--------------------------------------|--|--|
| 100C 3360 19 | After treatment - Diesel exhaust fluid controller | SCR main unit, communication error |
| 2049 3361 3 | After treatment - Diesel exhaust fluid dosing unit | SCR reductant dosing valve, short circuit to battery |
| 2047 3361 5 | After treatment - Diesel exhaust fluid dosing unit | SCR reductant dosing valve, open circuit |
| 208E 3361 10 | After treatment - Diesel exhaust fluid dosing unit | SCR main unit, reductant pressure not plausible |
| 202D 3362 2 | After treatment - Diesel exhaust fluid dosing unit input lines | SCR reductant pressure, error |
| 20C0 3363 0 | After treatment - Diesel exhaust fluid tank heater | SCR main unit, reductant heater, circuit high |
| 20BD 3363 2 | After treatment - Diesel exhaust fluid tank heater | SCR main unit, reductant heater, open load |
| 20C4 3363 3 | After treatment - Diesel exhaust fluid tank heater | SCR main unit, internal heating pump, short circuit to battery |
| 2044 3363 4 | After treatment - Diesel exhaust fluid tank heater | SCR main unit, reductant temperature sensor circuit low |
| 20C1 3363 5 | After treatment - Diesel exhaust fluid tank heater | SCR main unit, internal heating pump, open load |
| 20BE 3363 8 | After treatment - Diesel exhaust fluid tank heater | SCR main unit, reductant heater, circuit performance |
| 1054 3363 15 | After treatment - Diesel exhaust fluid tank heater | SCR reagent tank temperature too high |
| 101A 3363 16 | After treatment - Diesel exhaust fluid tank heater | SCR main unit, high temperature high limit exceeded |
| 209F 3363 17 | After treatment - Diesel exhaust fluid tank heater | SCR reductant tank temperature too low |
| 2045 3363 18 | After treatment - Diesel exhaust fluid tank heater | SCR main unit, low temperature limit exceeded |
| 0638 3464 2 | Engine throttle actuator control command | Throttle, control error |

※ Some fault codes are not applied to this machine.

| Fault code J1939 SPN J1939 FMI | Name | Description |
|--------------------------------------|--|--|
| 2103 3464 3 | Engine throttle actuator control command | Throttle Actuator, short circuit to +24V |
| 2102 3464 4 | Engine throttle actuator control command | Throttle Actuator, short circuit |
| 2101 3464 5 | Engine throttle actuator control command | Throttle Actuator, slow response |
| 2106 3464 6 | Engine throttle actuator control command | Throttle Actuator Control System - Forced Limited Power |
| 2111 3464 7 | Engine throttle actuator control command | Throttle, stuck in open position |
| 2112 3464 8 | Engine throttle actuator control command | Throttle, stuck in closed position |
| 20CA 3485 1 | After treatment - supply air pressure | SCR main unit, air pressure too low |
| 209A 3485 2 | After treatment - supply air pressure | SCR main unit, air pressure sensor after orifice circuit supply |
| 209D 3485 3 | After treatment - supply air pressure | SCR main unit, air pressure sensor after orifice circuit high |
| 209C 3485 4 | After treatment - supply air pressure | SCR main unit, air pressure sensor after orifice circuit low |
| 1014 3485 7 | After treatment - supply air pressure | SCR, air circuit blocked |
| 209B 3485 9 | After treatment - supply air pressure | SCR main unit, air pressure sensor after orifice performance |
| 1045 3485 18 | After treatment - supply air pressure | EEC, air supply low |
| 209E 3485 20 | After treatment - supply air pressure | SCR main unit, air pressure sensor after orifice plausible error |
| 1082 3563 11 | Engine intake manifold pressure | Boost pressure sensor and ambient pressure sensor do not correlate |
| 1069 3563 15 | Engine intake manifold pressure | Boost pressure sensor and ambient pressure sensor do not correlate |

※ Some fault codes are not applied to this machine.

| Fault code J1939 SPN J1939 FMI | Name | Description |
|--------------------------------------|---------------------------------|--|
| 0069 3563 17 | Engine intake manifold pressure | Boost pressure sensor and ambient pressure sensor do not correlate |
| F001 3607 2 | Engine emergency shutdown | Incorrect EMS shutdown |
| 2128 3673 3 | Engine throttle valve position | Throttle Position Sensor 2, short circuit to +24V |
| 2127 3673 4 | Engine throttle valve position | Throttle Position Sensor 2, short circuit to ground |
| 0406 3822 3 | Engine EGR valve position | EGR position sensor, short circuit to +24V |
| 0405 3822 4 | Engine EGR valve position | EGR position sensor, short circuit to ground |
| 1405 3822 7 | Engine EGR valve position | EGR SRA reports a warning during Learn Stops. |
| 049D 3822 8 | Engine EGR valve position | EGR position sensor, outside the permitted range |
| 1404 3822 12 | Engine EGR valve position | EGR SRA reports it has a continuous fault. |
| 1705 3822 13 | Engine EGR valve position | EGR position sensor, not plausible |
| 1406 3822 16 | Engine EGR valve position | EGR SRA reports a running conditions warning for high temp or low voltage. |
| 1402 3822 19 | Engine EGR valve position | EGR CAN timeout |
| 1813 3822 20 | Engine EGR valve position | EGR position sensor, voltage shows large variation in open position |
| 1814 3822 21 | Engine EGR valve position | EGR position sensor, voltage shows large variation in closed position |
| 244B 3936 2 | After treatment - DPF filter | Particulate filter, clogged |
| 242F 3936 6 | After treatment - DPF filter | Particulate filter, ash level too high |

※ Some fault codes are not applied to this machine.

| Fault code J1939 SPN J1939 FMI | Name | Description |
|--------------------------------------|---|---|
| 1802 3936 10 | After treatment - DPF filter | Exhaust temperature sensors, not plausible |
| 1049 4090 0 | Nox limit exceeded | NOx level after catalytic converter too high |
| 2BAD 4090 11 | Nox limit exceeded | NOx Exceedence - Root Cause Unknown |
| 20EE 4090 16 | Nox limit exceeded | SCR main unit, NOx level too high |
| 2BA8 4095 2 | Nox limit exceeded | NOx Exceedence - Interruption of Reagent Dosing Activity |
| 2BA7 4096 2 | Nox limit exceeded | NOx Exceedence - Empty Reagent Tank |
| 1309 4201 2 | Engine speed | Engine position sensor 1, faulty |
| 1302 4201 4 | Engine speed | Engine position sensor 1, too weak signal |
| 1213 4201 7 | Engine speed | Engine position sensor 1, faulty |
| 1303 4201 8 | Engine speed | Engine position sensor 1, Gap Puls or Sync error |
| 1308 4201 9 | Engine speed | Engine position sensor 1, time out |
| 1301 4201 10 | Engine speed | Engine position sensor 1, position diff |
| 0726 4202 2 | Engine speed | Engine speed sensor faulty |
| 2BAE 4225 2 | Nox limit exceeded | Failure in the NOx control monitoring system |
| 1040 4334 0 | After treatment Diesel exhaust fluid pressure | SCR reductant pressure error |
| 12C5 4334 1 | After treatment Diesel exhaust fluid pressure | EEC3 has demanded "SCR Hazardous functional failure reductant dosing stopped" actions |

| Fault code J1939 SPN J1939 FMI | Name | Description |
|--------------------------------------|---|--|
| 103D 4334 2 | After treatment Diesel exhaust fluid pressure | Urea pressure sensor, plausible error during start-up |
| 204D 4334 3 | After treatment Diesel exhaust fluid pressure | Urea pressure sensor, SCR high |
| 204C 4334 4 | After treatment Diesel exhaust fluid pressure | Urea pressure sensor, SCR low |
| 204B 4334 8 | After treatment Diesel exhaust fluid pressure | Urea pressure sensor, pressure too high not plausible |
| 1031 4374 0 | After treatment - Diesel exhaust fluid pump | Reductant pump fault, pump speed too high |
| 1030 4374 1 | After treatment - Diesel exhaust fluid pump | Reductant pump fault, pump speed too low |
| 16AC 4782 0 | DPF soot density | Particulate filter is clogged, hazardous |
| 16AB 4782 16 | DPF soot density | Particulate filter is clogged, major |
| 12CC 4809 2 | After treatment - DOC intake temp. | Upstream exhaust temperature sensor error |
| 16E0 4809 7 | After treatment - DOC intake temp. | Upstream exhaust temperature sensor, stuck |
| 12CE 4809 8 | After treatment - DOC intake temp. | Upstream exhaust temperature sensor error |
| 16FD 4809 9 | After treatment - DOC intake temp. | Upstream exhaust temperature sensor, not plausible |
| 1700 4809 16 | After treatment - DOC intake temp. | Upstream exhaust temperature sensor, above limit |
| 1701 4809 18 | After treatment - DOC intake temp. | Upstream exhaust temperature sensor, below limit |
| 16B1 4810 9 | After treatment - DOC outlet temp | Particulate filter, temperature drop not plausible |
| 2423 4810 18 | After treatment - DOC outlet temp | Upstream exhaust temperature too low during regeneration |

| Fault code J1939 SPN J1939 FMI | Name | Description |
|--------------------------------------|---|---|
| 2601 4814 2 | Engine coolant pump | Coolant water pump actuator, faulty |
| 2603 4814 3 | Engine coolant pump | Coolant water pump actuator, short circuit on high side |
| 2602 4814 4 | Engine coolant pump | Coolant water pump actuator, short circuit on low side |
| 1811 4814 7 | Engine coolant pump | Coolant pump speed sensor, stuck |
| 00B7 4814 8 | Engine coolant pump | Electrically controlled coolant pump |
| 1810 4814 10 | Engine coolant pump | Coolant pump speed sensor, no signal |
| 16EC 5285 1 | Engine CAC efficiency | Boost temperature to high, not plausible |
| 245B 5401 2 | Engine Turbocharger Turbine Bypass Actuator | EGR bypass actuator, faulty |
| 245D 5401 3 | Engine Turbocharger Turbine Bypass Actuator | EGR bypass actuator, short circuit high to +24V |
| 245C 5401 4 | Engine Turbocharger Turbine Bypass Actuator | EGR bypass actuator, short circuit high to ground |
| 245A 5401 5 | Engine Turbocharger Turbine Bypass Actuator | EGR bypass actuator, open load |
| 1717 5419 2 | Engine Throttle Actuator | Throttle M42, CAN interface fault |
| 1707 5419 3 | Engine Throttle Actuator | Throttle M42, supply voltage fault |
| 1716 5419 5 | Engine Throttle Actuator | Throttle M42, current limited |
| 170A 5419 6 | Engine Throttle Actuator | Throttle M42, overload |
| 1708 5419 9 | Engine Throttle Actuator | Throttle M42 has detected a CAN timeout |

| Fault code J1939 SPN J1939 FMI | Name | Description |
|--------------------------------------|--|---|
| 170B 5419 10 | Engine Throttle Actuator | Throttle M42, control error |
| 1710 5419 11 | Engine Throttle Actuator | Throttle M42, internal fault |
| 1711 5419 12 | Engine Throttle Actuator | Throttle M42, software execution error |
| 170D 5419 13 | Engine Throttle Actuator | Throttle M42, unsuccessful learning of the reference position |
| 1709 5419 14 | Engine Throttle Actuator | Throttle M42 has detected a CAN timeout |
| 1706 5419 16 | Engine Throttle Actuator | Throttle M42, too high temperature |
| 1714 5419 19 | Engine Throttle Actuator | Throttle M42, CAN timeout |
| 170F 5419 31 | Engine Throttle Actuator | Throttle M42, service mode enabled |
| 1426 5421 3 | Engine Turbocharger Wastegate Actuator | Wastegate actuator, short circuit to +24V |
| 0249 5421 4 | Engine Turbocharger Wastegate Actuator | Wastegate actuator, short circuit |
| 1425 5421 5 | Engine Turbocharger Wastegate Actuator | Wastegate actuator, short circuit to ground |
| 0247 5421 6 | Engine Turbocharger Wastegate Actuator | Wastegate actuator, short circuit |
| 1407 5543 2 | Engine Exhaust Brake Actuator Command | Exhaust brake actuator, control fault |
| 0478 5543 3 | Engine Exhaust Brake Actuator Command | Exhaust brake actuator, short circuit to +24V |
| 0477 5543 4 | Engine Exhaust Brake Actuator Command | Exhaust brake actuator, short circuit to ground |
| 1427 5543 5 | Engine Exhaust Brake Actuator Command | Exhaust brake actuator, stuck in open position |

| Fault code J1939 SPN J1939 FMI | Name | Description |
|--------------------------------------|---|--|
| 0475 5543 6 | Engine Exhaust Brake Actuator Command | Exhaust brake actuator, faulty |
| 1411 5543 7 | Engine Exhaust Brake Actuator Command | Exhaust brake actuator, stuck in closed position |
| 1428 5543 12 | Engine Exhaust Brake Actuator Command | Exhaust brake actuator, control fault |
| 1408 5543 13 | Engine Exhaust Brake Actuator Command | Exhaust brake actuator, fault with stop position |
| 1409 5543 16 | Engine Exhaust Brake Actuator Command | Exhaust brake actuator, over temperature |
| 1403 5543 19 | Engine Exhaust Brake Actuator Command | Exhaust brake actuator, CAN timeout |
| 0476 5543 21 | Engine Exhaust Brake Actuator Command | Exhaust brake actuator, error |
| 205B 5743 2 | Aftertreatment SCR Temperature | Reductant tank temperature sensor, not plausible |
| 205C 5743 4 | Aftertreatment SCR Temperature | Reductant tank temperature sensor, short circuit |
| 205A 5743 5 | Aftertreatment SCR Temperature | Reductant tank temperature sensor, open load |
| 202C 5745 3 | Aftertreatment Diesel Exhaust Fluid Dosing Unit Heater | SCR water valve, short circuit to battery |
| 202A 5745 5 | Aftertreatment Diesel Exhaust Fluid Dosing Unit Heater | SCR water valve, open load |
| 207F 5841 1 | Diesel Exhaust Fluid Quality Malfunction | SCR main unit, reductant quality too low |

5. AAVM FAULT CODE

| Fault Code | Description |
|------------|--|
| A01 | AAVM Communication Error -AAVM |
| A02 | AAVM Communication Error -Front Camera |
| A03 | AAVM Communication Error -Rear Camera |
| A04 | AAVM Communication Error -Left Camera |
| A05 | AAVM Communication Error -Right Camera |
| A06 | Manual Setting Fail |
| A07 | No MCU CID |
| A08 | MCU CID Format Error |
| A09 | AAVM Hardware Error -AAVM |
| A10 | AAVM Hardware Error -Front Camera |
| A11 | AAVM Hardware Error -Rear Camera |
| A12 | AAVM Hardware Error -Left Camera |
| A13 | AAVM Hardware Error -Right Camera |
| A14 | MCU CID Model is not registered |
| A15 | MCU CID Model can't be applied |

GROUP 12 ENGINE CONTROL SYSTEM

1. MCU and Engine ECM (Electronic Control Module)

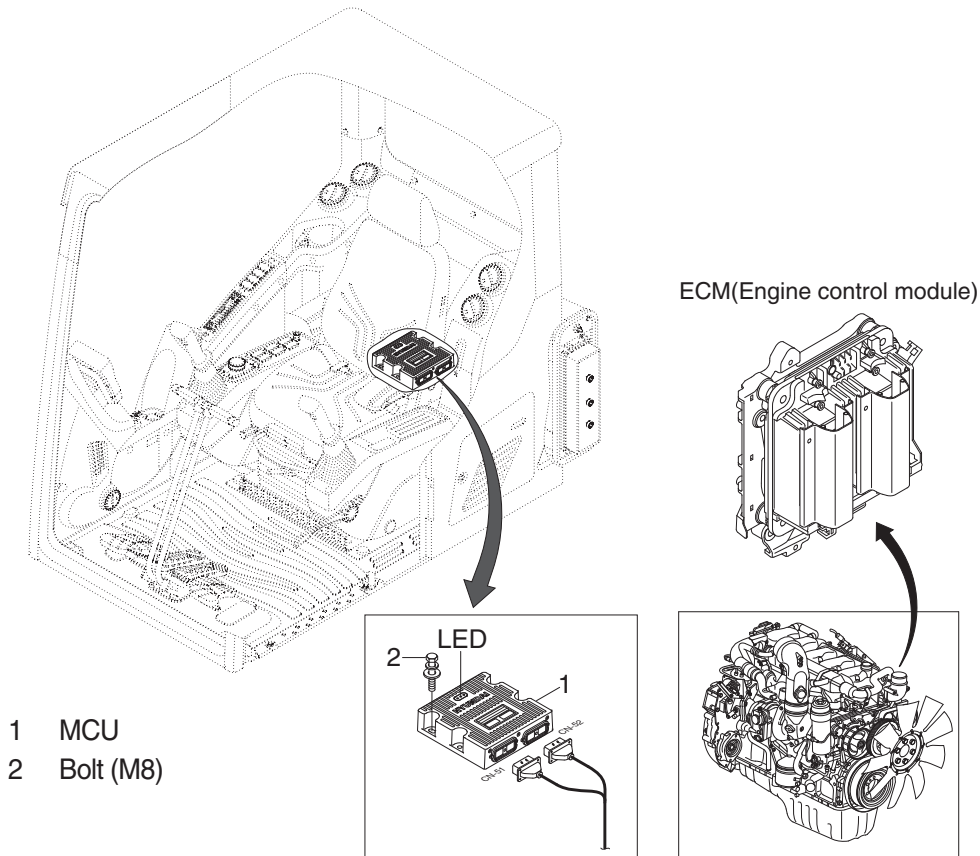

480F5MS10

2. MCU ASSEMBLY

1) To match the pump absorption torque with the engine torque, MCU varies EPPR valve output pressure, which control pump discharge amount whenever feedbacked engine speed drops under the reference rpm of each mode set.

2) Three LED lamps on the MCU display as below.

| LED lamp | Trouble | Service |
|--------------------------|--------------------------------------|--|
| G is turned ON | Normal | - |
| G and R are turned ON | Trouble on MCU | · Change the MCU |
| G and Y are turned ON | Trouble on serial communication line | · Check if serial communication lines between MCU and cluster are disconnected |
| Three LED are turned OFF | Trouble on MCU power | · Check if the input power wire (24 V, GND) of MCU is disconnected · Check the fuse |

G : green, R : red, Y : yellow

GROUP 13 EPPR VALVE

1. PUMP EPPR VALVE

1) COMPOSITION

EPPR (Electro Proportional Pressure Reducing) valve consists of electro magnet and spool valve installed at main pump.

(1) Electro magnet valve

Receive electric current from MCU and move the spool proportionally according to the specific amount of electric current value.

(2) Spool valve

Is the two way direction control valve for pilot pressure to reduce main pump flow.

When the electro magnet valve is activated, pilot pressure enters into flow regulator of main pump.

(3) Pressure and electric current value for each mode

| Mode | | Pressure | | Electric current (mA) | Engine rpm (at accel dial 10) |
|----------|---|---------------------|----------|-----------------------|-------------------------------|
| | | kgf/cm ² | psi | | |
| Standard | P | 8 | 114 | 280 ± 30 | 1750 ± 50 |
| | S | 10 ± 3 | 142 ± 40 | 305 ± 30 | 1650 ± 50 |
| | E | 13 ± 3 | 185 ± 40 | 340 ± 30 | 1550 ± 50 |
| Option | P | 0 | 0 | 230 ± 30 | 1850 ± 50 |
| | S | 0 | 0 | 260 ± 30 | 1800 ± 50 |
| | E | 5 ± 3 | 71 ± 40 | 340 ± 30 | 1600 ± 50 |

2) HOW TO SWITCH THE POWER SHIFT (STANDARD ↔ OPTION) ON THE CLUSTER

You can switch the EPPR valve pressure set by selecting the power shift (standard ↔ option).

- Management
 - Service menu

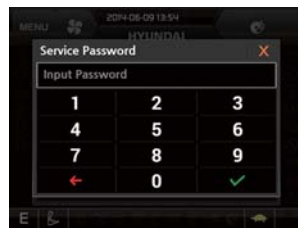

Enter the password



- Power shift (standard/option) : Power shift pressure can be set by option menu.

3) OPERATING PRINCIPLE (pump EPPR valve)

(1) Structure

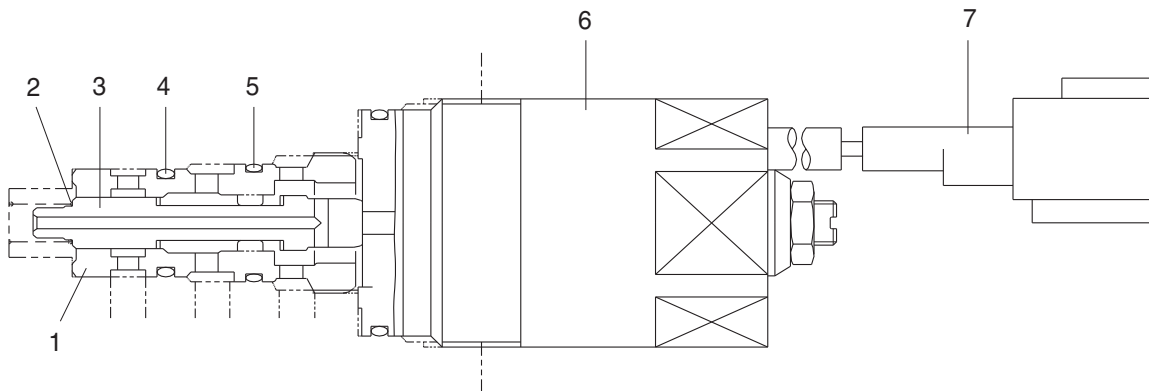

5-22(1)

- | | | |
|----------|----------|------------------|
| 1 Sleeve | 4 O-ring | 6 Solenoid valve |
| 2 Spring | 5 O-ring | 7 Connector |
| 3 Spool | | |

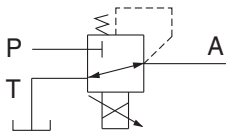

- | | |
|---|---|
| P | Pilot oil supply line (pilot pressure) |
| T | Return to tank |
| A | Secondary pressure to flow regulator at main pump |

(2) Neutral

Pressure line is blocked and A oil returns to tank.

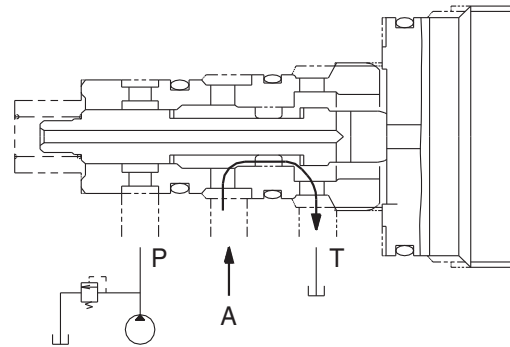
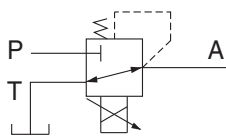

(3) Operating

Secondary pressure enters into A.

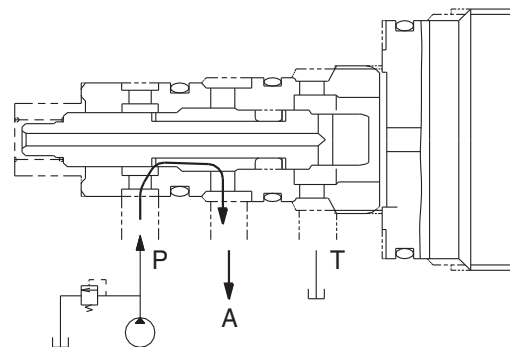
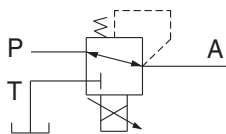

5-22(2)

4) EPPR VALVE CHECK PROCEDURE

(1) Check electric current value at EPPR valve

- ① Disconnect connector CN-75 from EPPR valve.
- ② Insert the adapter to CN-75 and install multimeter as figure.
- ③ Start engine.
- ④ Set S-mode and cancel auto decel mode.
- ⑤ Position the multimodal dial at 10.
- ⑥ If rpm display show approx 1650 ± 50 rpm check electric current at bucket circuit relief position.
- ⑦ Check electric current at bucket circuit relief position.

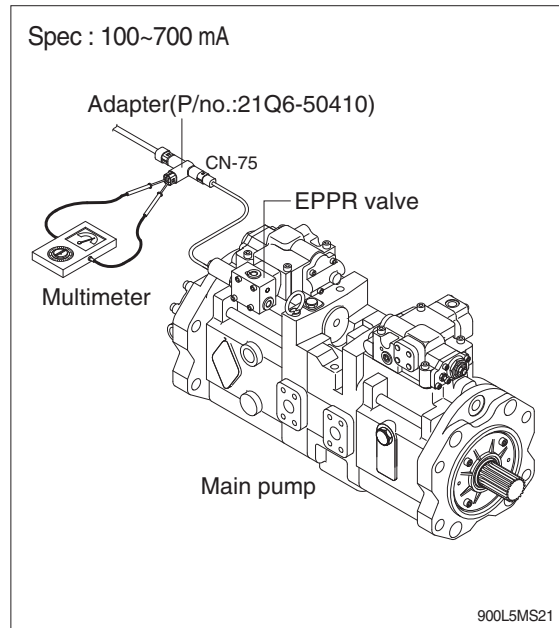

(2) Check pressure at EPPR valve

- ① Remove plug and connect pressure gauge as figure.
 - Gauge capacity : 0 to 50 kgf/cm²
(0 to 725 psi)
- ② Start engine.
- ③ Set S-mode and cancel auto decel mode.
- ④ Position the multimodal dial at 10.
- ⑤ If tachometer show approx 1650 ± 50 rpm check pressure at relief position of bucket circuit by operating bucket control lever.
- ⑥ If pressure is not correct, adjust it.
- ⑦ After adjust, test the machine.

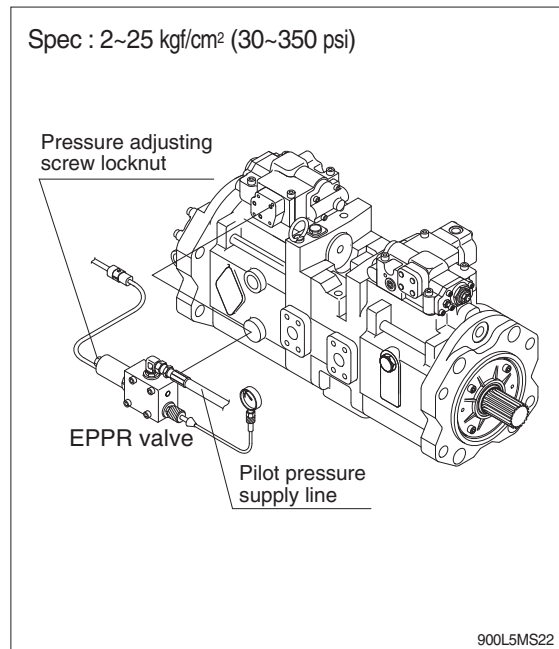

2. BOOM PRIORITY EPPR VALVE

1) COMPOSITION

The boom priority EPPR valve is built in a manifold and mainly consisting of valve body and coil. This EPPR valve installed under the solenoid valve.

2) CONTROL

The boom priority EPPR valve has to be controlled by a specific electronic amplifier card, which is supplying the coil with a current 580 mA at 30Ω and 24 V.

3) OPERATING PRINCIPLE

(1) Structure

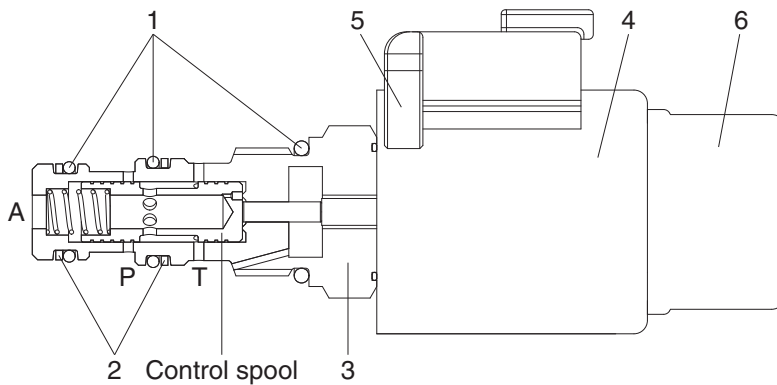

21095MS14

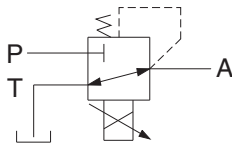

P : Pilot supply line
T : Return to tank
A : Secondary pressure to flow MCV

- | | | |
|----------------|--------------|-------------|
| 1 O-ring | 3 Valve body | 5 Connector |
| 2 Support ring | 4 Coil | 6 Cover cap |

(2) Operation

In de-energized mode the inlet port (P) is closed and the outlet port (A) is connected to tank port (T).

In energized mode the solenoid armature presses onto the control spool with a force corresponding to the amount of current. This will set a reduced pressure at port A. The setting is proportional to the amount of current applied.

(3) Maximum pressure relief

If a pressure from outside is applied on port A the valve may directly switch to tank port (T) and protect the system before overload.

2) EPPR VALVE CHECK PROCEDURE

(1) Check electric current value at EPPR valve

- ① Disconnect connector CN-133 from EPPR valve.
- ② Insert the adapter to CN-133 and install multimeter as figure.
- ③ Start engine.
- ④ Set S-mode and cancel auto decel mode.
- ⑤ If rpm display approx 1650 ± 50 rpm disconnect one wire harness from EPPR valve.
- ⑥ Check electric current in case of combined boom up and swing operation.

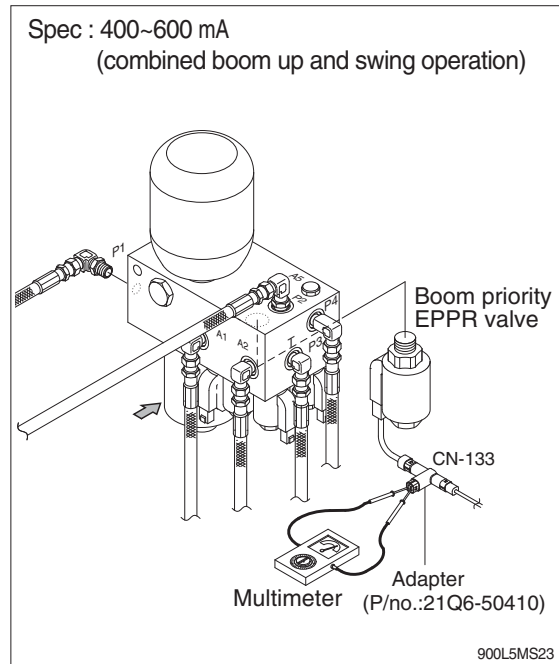

(2) Check pressure at EPPR valve

- ① Remove hose from A5 port and connect pressure gauge as figure.
 - Gauge capacity : 0 to 50 kgf/cm²
(0 to 725 psi)
- ② Start engine.
- ③ Set S-mode and cancel auto decel mode.
- ④ If rpm display approx 1650 ± 50 rpm check pressure (In case of combined boom up and swing operation).
- ⑤ If pressure is not correct, adjust it.
- ⑥ After adjust, test the machine.

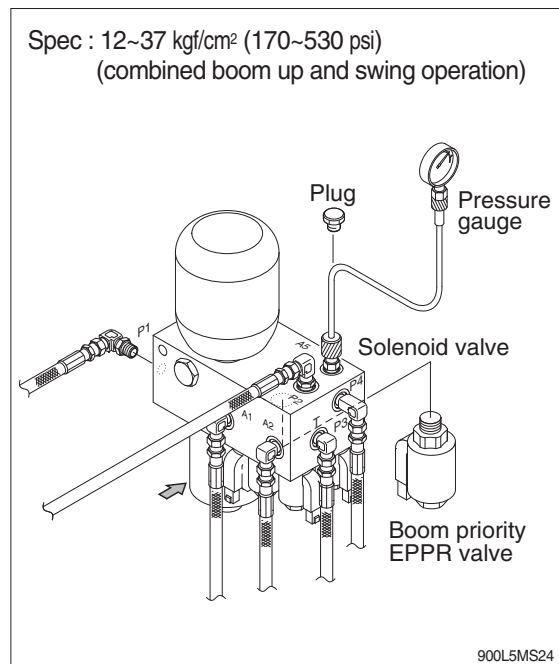

GROUP 14 MONITORING SYSTEM

1. OUTLINE

Monitoring system consists of the monitor part and switch part.

The monitor part gives warnings when any abnormality occurs in the machine and informs the condition of the machine.

Various select switches are built into the monitor panel, which act as the control portion of the machine control system.

2. CLUSTER

1) MONITOR PANEL



900L5MS13

※ The warning lamp pops up and/or blinks and the buzzer sounds when the machine has a problem.

The warning lamp blinks until the problem is cleared. Refer to page 5-86 for details.

※ This cluster is adjustable.

- Vertical (forward/backward) : each 15°
- Horizontal (left only) : 8°

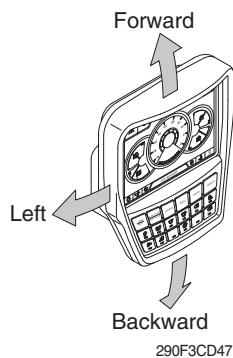

2) CLUSTER CHECK PROCEDURE

(1) Start key : ON

① Check monitor

- a. Buzzer sounding for 4 seconds with HYUNDAI logo on cluster.
- ※ If the ESL mode is set to the enable, enter the password to start engine.

② After initialization of cluster, the operating screen is displayed on the LCD.

Also, self diagnostic function is carried out.

- a. Engine rpm display : 0 rpm
- b. Engine coolant temperature gauge : White range
- c. Hydraulic oil temperature gauge : White range
- d. Fuel level gauge : White range

③ Indicating lamp state

- a. Power mode pilot lamp : E mode or U mode
- b. Work mode pilot lamp : General operation mode (bucket)
- c. Travel speed pilot lamp : Low (turtle)

(2) Start of engine

① Check machine condition

- a. RPM display indicates at present rpm
- b. Gauge and warning lamp : Indicate at present condition.
- ※ When normal condition : All warning lamp OFF
- c. Work mode selection : General work
- d. Power mode selection : E mode or U mode
- e. Travel speed pilot lamp : Low (turtle)

② When warming up operation

- a. Warming up pilot lamp : ON
- b. After engine started, engine speed increases to 1000 rpm.
- ※ Others same as above.

③ When abnormal condition

- a. The warning lamp lights up and the buzzer sounds.
- b. If BUZZER STOP switch is pressed, buzzer sound is canceled but the lamp warning lights up until normal condition.
- ※ The pop-up warning lamp moves to the original position and blink when the buzzer stop switch is pushed. Also the buzzer stops.

2) GAUGE

(1) Operation screen

When you first turn starting switch ON, the operation screen will appear.

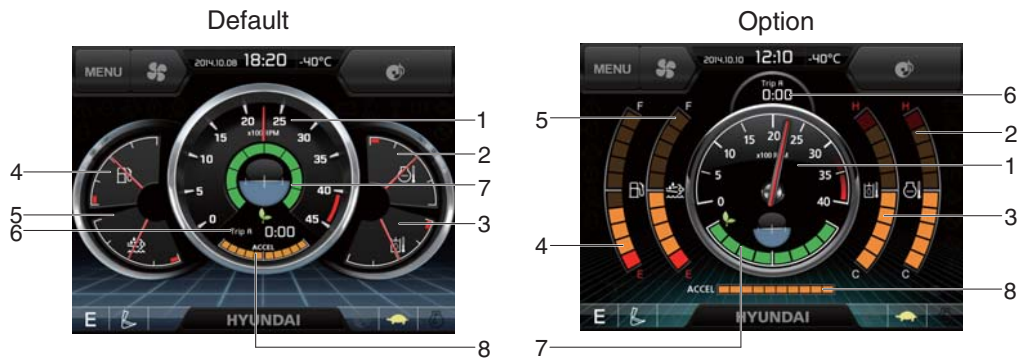

290F3CD51

- | | |
|------------------------------------|---------------------------|
| 1 RPM / Speed gauge | 5 DEF/AdBlue® level gauge |
| 2 Engine coolant temperature gauge | 6 Tripmeter display |
| 3 Hydraulic oil temperature gauge | 7 Eco gauge |
| 4 Fuel level gauge | 8 Accel dial gauge |

※ Operation screen type can be set by the screen type menu of the display.

Refer to page 5-108 for details.

(2) RPM / Speed gauge





290F3CD49

- ① This display the engine speed.

(3) Engine coolant temperature gauge





290F3CD53

- ① This gauge indicates the temperature of coolant.
- White range : 40-107°C (104-225°F)
 - Red range : Above 107°C (225°F)
- ② If the indicator is in the red range or  lamp pops up and the buzzer sounds turn OFF the engine and check the engine cooling system.
- ※ If the gauge indicates the red range or  lamp blinks in red even though the machine is on the normal condition, check the electric device as that can be caused by the poor connection of electricity or sensor.

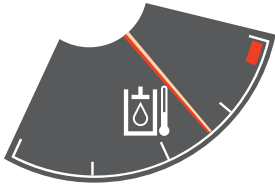
(4) Hydraulic oil temperature gauge





290F3CD54

- ① This gauge indicates the temperature of hydraulic oil.
 - White range : 40-105°C(104-221°F)
 - Red range : Above 105°C(221°F)
 - ② If the indicator is in the red range or  lamp pops up and the buzzer sounds reduce the load on the system. If the gauge stays in the red range, stop the machine and check the cause of the problem.
- ※ If the gauge indicates the red range or  lamp blinks in red even though the machine is on the normal condition, check the electric device as that can be caused by the poor connection of electricity or sensor.

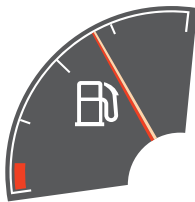
(5) Fuel level gauge





290F3CD55

- ① This gauge indicates the amount of fuel in the fuel tank.
 - ② Fill the fuel when the red range, or  lamp pops up and the buzzer sounds.
- ※ If the gauge indicates the red range or  lamp blinks in red even though the machine is on the normal condition, check the electric device as that can be caused by the poor connection of electricity or sensor.

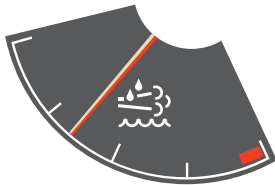
(6) DEF/AdBlue® Level gauge



290F3CD57

- ① This gauge indicates the amount of liquid in the DEF/AdBlue® tank.
 - ② Fill the DEF/AdBlue® when the red range, or  lamp pops up and the buzzer sounds.
 - ③ Do not pour DEF/AdBlue® any more when the DEF/AdBlue® fill up warning lamp lights ON.
- ※ Refer to page 5-90.
- ※ If the gauge indicates the red range or  lamp blinks in red even though the machine is on the normal condition, check the electric device as that can be caused by the poor connection of electricity or sensor.

(7) Tripmeter display

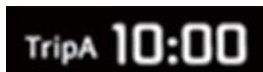

290F3CD56

- ① This displays the engine the tripmeter.
- ※ Refer to page 5-110 for details.

(8) Eco gauge

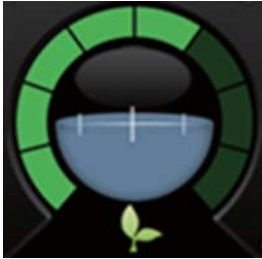

290F3CD58

- ① This gauge indicates the fuel consumption rate and machine load status. So that operators can be careful with fuel economy.
- ② The fuel consumption rate or machine load is higher, the number of segment is increased.
- ③ The color of Eco gauge indicates operation status.
 - White : Idle operation
 - Green : Economy operation
 - Yellow : Non-economy operation at a medium level.
 - Red : Non-economy operation at a high level.

(9) Accel dial gauge



290F3CD59



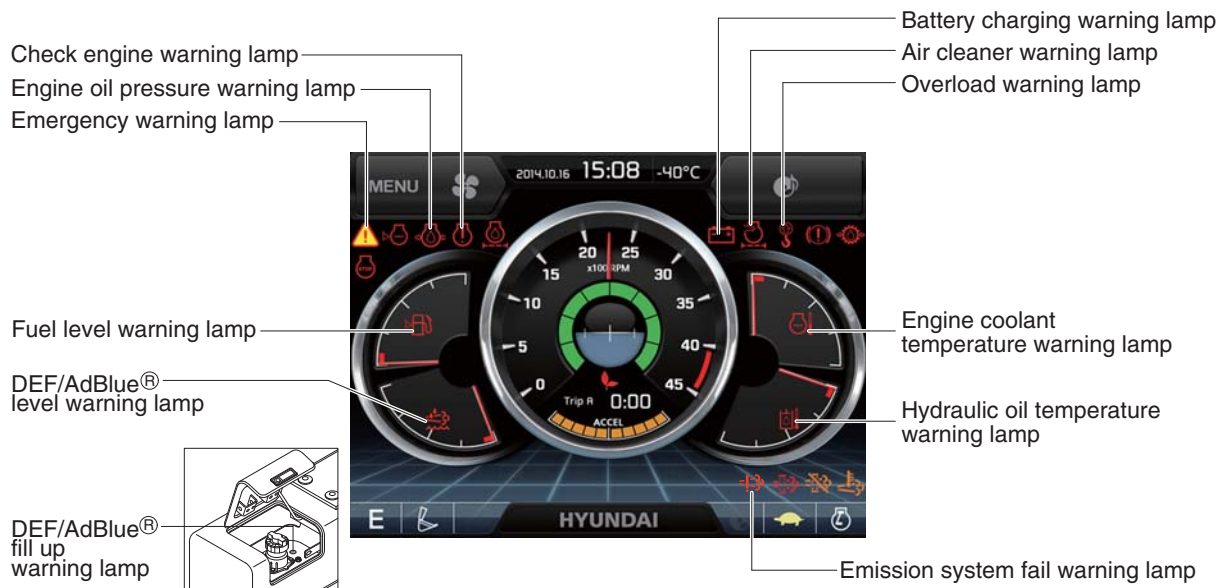

- ① This gauge indicates the level of accel dial.

3) WARNING LAMPS



480F3CD60

※ Warning lamps and buzzer





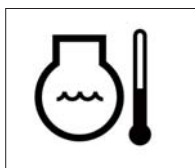

| Warnings | When error happened | Lamps and buzzer |
|---|---|--|
| All warning lamps except below | Warning lamp pops up on the center of the LCD and the buzzer sounds | <ul style="list-style-type: none"> The pop-up warning lamp moves to the original position and blinks, and the buzzer stops when ; - the buzzer stop switch  is pushed - the knob of the haptic controller is pushed - the lamp of the LCD is touched |
|  | Warning lamp pops up on the center of the LCD and the buzzer sounds | <ul style="list-style-type: none"> The pop-up warning lamp moves to the original position and light ON or blinks, and the buzzer stops when ; - the buzzer stop switch  is pushed - the knob of the haptic controller is pushed - the lamp of the LCD is touched <p>※ Refer to page 5-90 for details.</p> |
|  | Warning lamp pops up on the center of the LCD and the buzzer sounds | <p>※ Refer to page 5-87 for details.</p> |

※ Refer to page 5-95 for the buzzer stop switch  and operator's manual page 3-57 for the haptic controller.

(1) Engine coolant temperature warning lamp







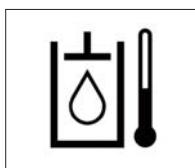

290F3CD61

- ① Engine coolant temperature warning is indicated two steps.
 - 103°C over : The  lamp pops up and the buzzer sounds.
 - 107°C over : The  lamp pops up and the buzzer sounds.
- ② The pop-up ,  lamps move to the original position and blinks when the buzzer stop switch  is pushed. And the buzzer stops and ,  lamps keep blink.
- ③ Check the cooling system when the lamps keep blink.

(2) Hydraulic oil temperature warning lamp



290F3CD62

- ① Hydraulic oil temperature warning is indicated two steps.
 - 100°C over : The  lamp pops up and the buzzer sounds.
 - 105°C over : The  lamp pops up and the buzzer sounds.
- ② The pop-up ,  lamps move to the original position and blinks when the buzzer stop switch  is pushed. And the buzzer stops and ,  lamps keep blink.
- ③ Check the hydraulic oil level and hydraulic oil cooling system.

(3) Fuel level warning lamp

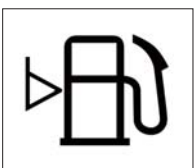

290F3CD63

- ① This warning lamp pops up and the buzzer sounds when the level of fuel is below 210 ℓ (55.5 U.S. gal).
- ② Fill the fuel immediately when the lamp blinks.

(4) Emergency warning lamp



290F3CD64

- ① This warning lamp pops up and the buzzer sounds when each of the below warnings is happened.
 - Engine coolant overheating (over 107°C)
 - Hydraulic oil overheating (over 105°C)
 - MCU input voltage abnormal
 - Cluster communication data error
 - Engine ECM communication data error
- ※ The pop-up warning lamp moves to the original position and blinks when the buzzer stop switch  is pushed. And the buzzer stops.
- ② When this warning lamp blinks, machine must be checked and serviced immediately.

(5) Engine oil pressure warning lamp

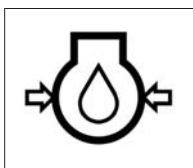

290F3CD65

- ① This warning lamp pops up and the buzzer sounds when the engine oil pressure is low.
- ② If the lamp blinks, shut OFF the engine immediately. Check oil level.

(6) Check engine warning lamp



290F3CD66

- ① This warning lamp pops up and the buzzer sounds when the communication between MCU and engine ECM on the engine is abnormal, or if the cluster received specific fault code from engine ECM.
- ② Check the communication line between them.
If the communication line is OK, then check the fault codes on the cluster.

(7) Battery charging warning lamp

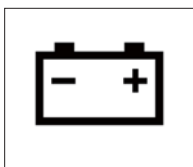

290F3CD67

- ① This warning lamp pops up and the buzzer sounds when the battery charging voltage is low.
- ② Check the battery charging circuit when this lamp blinks.

(8) Air cleaner warning lamp

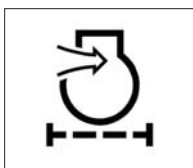

290F3CD68

- ① This warning lamp pops up and the buzzer sounds when the filter of air cleaner is clogged.
- ② Check the filter and clean or replace it.

(9) Overload warning lamp (opt)



290F3CD69

- ① When the machine is overload, the overload warning lamp pops up and the buzzer sounds during the overload switch is ON. (if equipped)
- ② Reduce the machine load.

(10) Emission system fail warning lamp

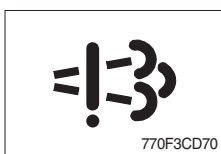

- ① This warning lamp lights ON if there are faults on the SCR system.
- ※ In the case of some faults, the torque is reduced.
- ※ Please contact your Hyundai service center or local dealer.

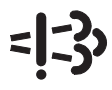
| Warning lamp | | Torque reduction |
|---|------------------|--|
|  | Time | |
| On | Fault detected | - |
| Blink | After 30 minutes | · Torque is reduced by 1% per minute to 70% of the highest torque. |
| Blink rapidly | After 4 hours | · Torque is reduced by to 0% (low idling) within 2~10 minutes. |

- ※ Once the fault has been remedied and the engine control unit has received an indication that it is working, torque returns to the normal level.
- ※ If a new fault occurs within 40 hours of operation since the first fault, the warning lamp will come ON. After 30 minutes of operation, the warning lamp will blink rapidly and torque will be reduced to 0% (low idling) within 30 minutes.

(11) DEF/AdBlue® level warning lamp



290F3CD257

- ① This warning lamp indicates when ON or blinking, that the DEF/AdBlue® level is low as table below.
- ※ It is recommended that the DEF/AdBlue® tank be filled completely full of the DEF/AdBlue® in order to correct any fault conditions.
- ※ The engine resumes normal torque after DEF/AdBlue® has been filled to a level of at least 20%.

| Warning lamp | | Description |
|---|-------------------|--|
|  | DEF/AdBlue® level | |
| On | 20% | <ul style="list-style-type: none"> · The DEF/AdBlue® level has fallen below the initial warning level (20%). |
| Blink | 10% | <ul style="list-style-type: none"> · The DEF/AdBlue® level has fallen below the critical warning level (10%). · Torque is reduced by 1% per minute to 70% of the highest torque. |
| Blink rapidly | 0% | <ul style="list-style-type: none"> · This is happened when 30 minutes elapsed with empty conditions (0%) of the DEF/AdBlue® tank. · Torque is reduced by to 0% (low idling) within 2~10 minutes. |

(12) DEF/AdBlue® fill up warning lamp

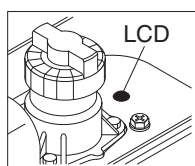

290F3CD272











- ① This lamp lights ON when the DEF/AdBlue® tank is completely filled with DEF/AdBlue®.
- ※ Fill the tank with the DEF/AdBlue® after start switch ON and then turn OFF the start switch.
- ※ Do not pour DEF/AdBlue® any more when this lamp lights ON. Otherwise DEF/AdBlue® tank may freeze and burst in winter season.

4) PILOT LAMPS



290F3CD74A

(1) Mode pilot lamps

| No | Mode | Pilot lamp | Selected mode |
|----|----------------|---|----------------------------|
| 1 | Power mode |  | Heavy duty power work mode |
| | |  | Standard power mode |
| | |  | Economy power mode |
| 2 | User mode |  | User preferable power mode |
| 3 | Work mode |  | General operation mode |
| | |  | Breaker operation mode |
| | |  | Crusher operation mode |
| 4 | Travel mode |  | Low speed traveling |
| | |  | High speed traveling |
| 5 | Auto idle mode |  | Auto idle |

(2) Power max pilot lamp



290F3CD78

- ① The lamp will be ON when pushing power max switch on the LH RCV lever.
 - ② The power max function is operated maximum 8 seconds.
- ※ Refer to the operator's manual page 3-37 for power max function.

(3) Warming up pilot lamp

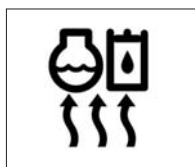

290F3CD80

- ① This lamp is turned ON when the coolant temperature is below 30°C (86°F).
- ② The automatic warming up is cancelled when the engine coolant temperature is above 30°C, or when 10 minutes have passed since starting the engine.

(4) Decel pilot lamp



290F3CD81

- ① Operating one touch decel switch on the RCV lever makes the lamp ON.
 - ② Also, the lamp will be ON and engine speed will be lowered automatically to save fuel consumption when all levers and pedals are at neutral position, and the auto idle function is selected.
- ※ **One touch decel is not available when the auto idle pilot lamp is turned ON.**
- ※ **Refer to the operator's manual page 3-36.**

(5) Fuel warmer pilot lamp

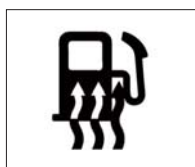

290F3CD82

- ① This lamp is turned ON when the coolant temperature is below 10°C (50°F) or the hydraulic oil temperature 20°C (68°F).
- ② The automatic fuel warming is cancelled when the engine coolant temperature is above 60°C, and the hydraulic oil temperature is above 45°C since the start switch was ON position.

(6) Maintenance pilot lamp



290F3CD83

- ① This lamp will be ON when the consuming parts are needed to change or replace. It means that the change or replacement interval of the consuming parts remains below 30 hours.
 - ② Check the message in maintenance information of main menu. Also, this lamp lights ON for 3 minutes when the start switch is ON position.
- ※ **Refer to the page 5-103.**

(7) Entertainment pilot lamp



290F3CD84

- ① This lamp is on when audio or video files are playing.
- ※ **Refer to the page 5-109.**

(8) Smart key pilot lamp (opt)



290F3CD214

- ① This lamp is ON when the engine is started by the start button.
- ② This lamp is red when the authentication fails, green when succeeds.
- ※ **Refer to the page 5-104.**

5) SWITCHES



290F3CD86

※ When some of the switches are selected, the pilot lamps are displayed on the LCD. Refer to the page 5-91 for details.

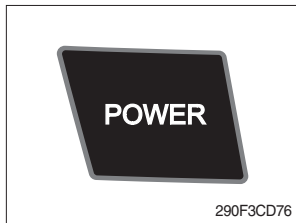

(1) Power mode switch

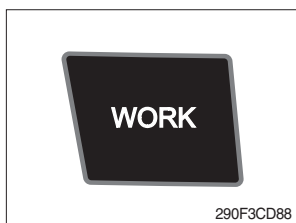

- ① This switch is to select the machine power mode and selected power mode pilot lamp is displayed on the pilot lamp position.
 - P : Heavy duty power work.
 - S : Standard power work.
 - E : Economy power work.
- ② The pilot lamp changes E → S → P → E in order.

(2) Work mode switch



- ① This switch is to select the machine work mode, which shifts from general operation mode to optional attachment operation mode.
 -  : General operation mode
 -  : Breaker operation mode (if equipped)
 -  : Crusher operation mode (if equipped)
 - Not installed : Breaker or crusher is not installed.

※ Refer to the operator's manual page 4-7 for details.

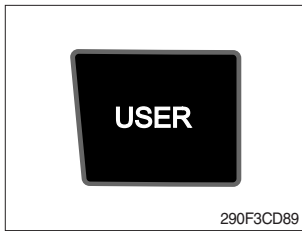

(3) User mode switch



- ① This switch is used to memorize the current machine operating status in the MCU and activate the memorized user mode.
 - Memory : Automatically saved after key OFF.
 - Action : Push this switch.
 - Cancel : Push this switch once more.
- ② Refer to the page 5-99 for another set of user mode.

(4) Travel speed switch



- ① This switch is used to select the travel speed alternatively.
 -  : Low speed
 -  : High speed
- ※ Do not change the setting of the travel speed switch. Machine stability may be adversely affected.
- ⚠ Personal injury can result from sudden changes in machine stability.

(5) Auto idle/ buzzer stop switch

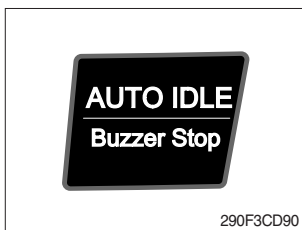

- ① This switch is used to activate or cancel the auto idle function.
 - Pilot lamp ON : Auto idle function is activated.
 - Pilot lamp OFF : Auto idle function is cancelled.
- ② The buzzer sounds when the machine has a problem. In this case, push this switch and buzzer stops, but the warning lamp blinks until the problem is cleared.

(6) Escape/Camera switch

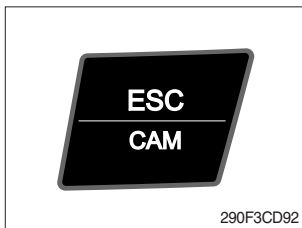

- ① This switch is used to return to the previous menu or parent menu.
- ② In the operation screen, pushing this switch will display the view of the camera on the machine (if equipped). Please refer to page 5-110 for the camera.
- ③ If the camera is not installed, this switch is used only ESC function.

(7) Work light switch



- ① This switch is used to operate the work light.
- ② The pilot lamp is turned ON when operating the switch.

(8) Head light switch

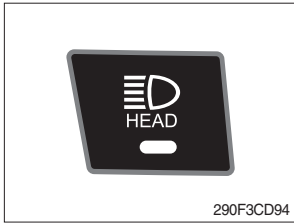

- ① This switch is used to operate the head light.
- ② The pilot lamp is turned ON when operating the switch.

(9) Intermittent wiper switch



- ① This switch is used to wipe operates intermittently.
- ② The pilot lamp is turned ON when operating the switch.

(10) Wiper switch



- ① This switch is used to operate the window wiper.
- ② Note that the wiper will self-park when switched off.
- ③ The pilot lamp is turned ON when operating the switch.
- ※ **If the wiper does not operate with the switch in ON position, turn the switch OFF immediately. Check the cause. If the switch remains ON, motor failure can result.**

(11) Washer switch



- ① The washer liquid is sprayed and the wiper is operated only while pressing this switch.
- ② The pilot lamp is turned ON when operating the switch.

(12) Cab light switch



- ① This switch turns ON the cab light on the cab.
- ② The pilot lamp is turned ON when operating the switch.

(13) Beacon switch

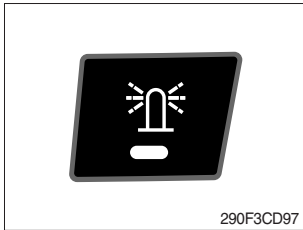

- ① This switch turns ON the rotary light on the cab.
- ② The pilot lamp is turned ON when operating the switch.

(14) Overload switch

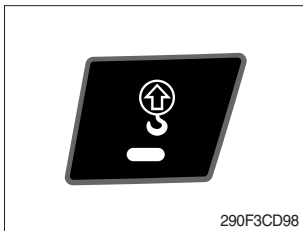

- ① When this switch turned ON, buzzer makes sound and overload warning lamp comes ON in case that the machine is overload.
 - ② When it turned OFF, buzzer stops and warning lamp goes out.
- ▲ Overloading the machine could impact the machines stability which could result in tipover hazard. A tipover hazard could result in serious injury or death. Always activate the overload warning device before you handle or lift objects.**

(15) Travel alarm switch

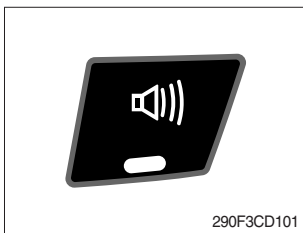

- ① This switch is to activate travel alarm function surrounding when the machine travels.
 - ON : The travel alarm function is activated.
 - OFF : The travel alarm function is not activated.

(16) Air conditioner quick touch switch



- ① This switch used to select air conditioner control mode.
※ Refer to the page 5-112.

(17) Main menu quick touch switch



- ① This switch is to activate the main menu in the cluster.
※ Refer to the page 5-98.

(18) Entertainment quick touch switch



- ① This switch is to activate the entertainment control menu in the cluster.
※ Refer to the page 5-109.

6) MAIN MENU

- ※ You can select or set the menu by the haptic controller or touch screen.
On the operation screen, tap MENU to access the main menu screen.
On the sub menu screen, you can tap the menu bar to access functions or applications.



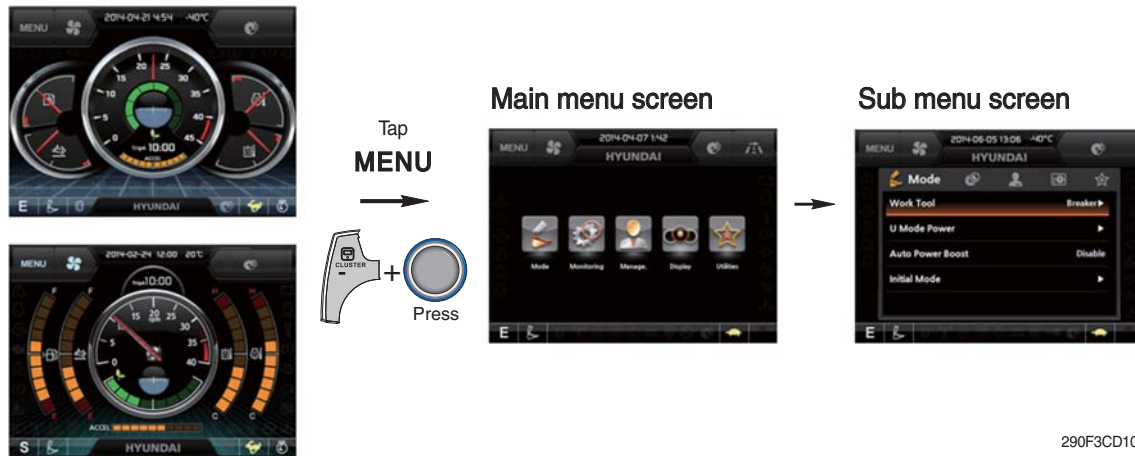

· Operation screen



290F3CD102

- ※ Please refer to the haptic controller, operator's manual page 3-57 for selection and change of menu and input value.

(1) Structure

| No | Main menu | Sub menu | Description |
|----|---|--|---|
| 1 |  Mode 290F3CD103 | Work tool U mode power Boom/Arm speed Auto power boost Auto engine shutdown (option) Initial mode Emergency mode | Breaker, Crusher, Not installed User mode only Boom speed, Arm speed Enable, Disable One time, Always, Disable Key on initial mode, Accel initial mode / step Switch function |
| 2 |  Monitoring 290F3CD104 | Active fault Logged fault Delete logged fault Monitoring | MCU, Engine ECM MCU, Engine ECM All logged fault delete, Initialization canceled Machine information, Switch status, Output status, |
| 3 |  Management 290F3CD105 | Fuel rate information Maintenance information Machine security Machine information Contact Service menu Clinometer Update | General record, Hourly, Daily, Mode record Replacement, Change interval oils and filters ESL mode setting, Password change Model, MCU, Monitor, Haptic / switch controller, RMCU, Relay drive unit, FATC, AAVM (opt) A/S phone number, A/S phone number change Power shift, Operating hour, IPC mode, Breaker mode pump acting, EPPR current level, Overload pressure Clinometer setting Cluster, ETC device |
| 4 |  Display 290F3CD106 | Display item Clock Brightness Unit setup Language selection Screen type | Engine speed, Tripmeter A, Tripmeter B, Tripmeter C Clock Manual, Auto Temperature, Pressure, Flow, Distance, Date format Korean, English, Chinese, ETC A type, B type |
| 5 |  Utilities 290F3CD107 | Entertainment Tripmeter Camera | Play Video, Audio, Smart terminal. 3 kinds (A, B, C) Number of active, Display order, AAVM (opt) |

(2) Mode setup

① Work tool

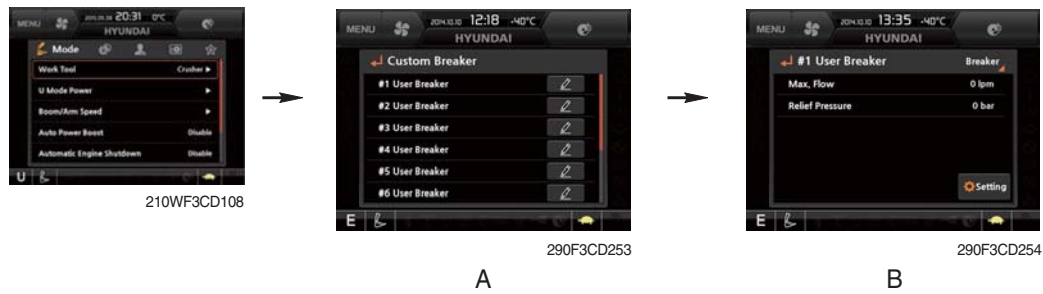

- Select on installed optional attachment
 - A : It can set the user's attachment.
It is available in setting #1~#10.
 - B : Max flow - Set the maximum flow for the attachment.
Relief pressure - Set the relief pressure.

② U mode power

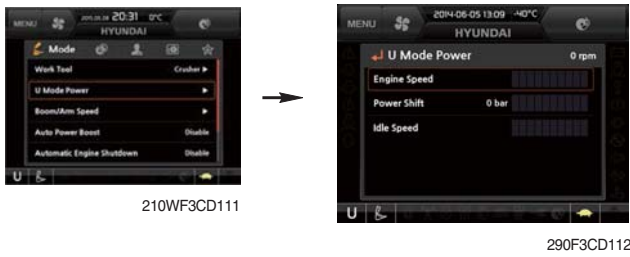

- Engine high idle rpm, auto idle rpm and pump torque (power shift) can be modulated and memorized separately in U-mode.
- U-mode can be activated by user mode switch.

| Step (█) | Engine speed (rpm) | Idle speed (rpm) | Power shift (bar) |
|----------|--------------------|-------------------|-------------------|
| 1 | 1450 | 800 | 0 |
| 2 | 1500 | 850 | 3 |
| 3 | 1600 | 900 | 6 |
| 4 | 1700 | 950 | 9 |
| 5 | 1750 | 1000 (auto decel) | 12 |
| 6 | 1800 | 1050 | 16 |
| 7 | 1850 | 1100 | 20 |
| 8 | 1900 | 1150 | 26 |
| 9 | 1950 | 1180 | 32 |
| 10 | 2000 | 1200 | 38 |

※ One touch decel & low idle : 850 rpm

③ Auto power boost

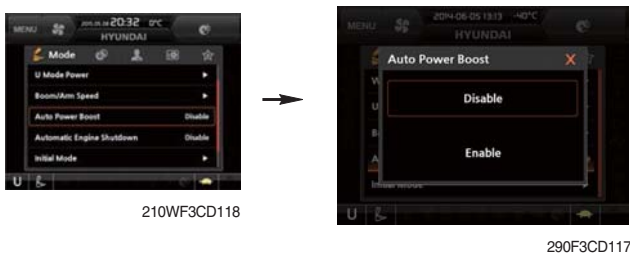

- The power boost function can be activated or cancelled.
 - Enable - The digging power is automatically increased as working conditions by the MCU.
It is operated max 8 seconds.
 - Disable - Not operated.

④ Automatic engine shutdown (option)



- The automatic engine shutdown function can be set by this menu.
 - One time
 - Always
 - Disable
 - Wait time setting : Max 40 minutes, min 2 minutes

⑤ Initial mode



- **Key on initial mode**
 - Selected the power mode is activated when the engine is started.
- **Accel initial mode**
 - Last setting value
 - User setting value
- **Accel initial step**
 - 0~9 step

⑥ Emergency mode



- This mode can be use when the switches are abnormal on the cluster.
- The cluster switches will be selected by touched each icon.

(3) Monitoring

① Active fault



- The logged faults of the MCU, engine ECM or air conditioner can be checked by this menu.

② Logged fault

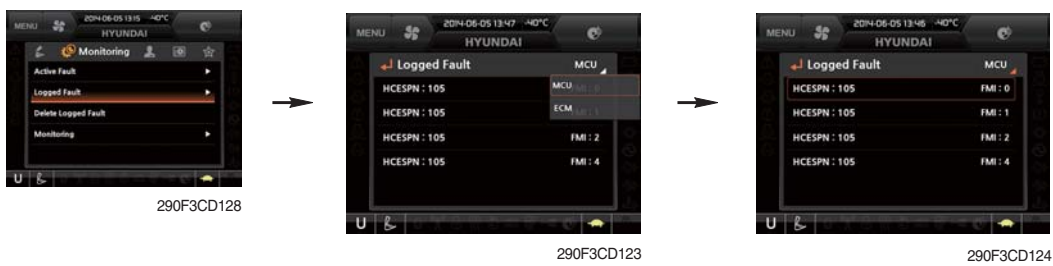

- The logged faults of the MCU, engine ECM or air conditioner can be checked by this menu.

③ Delete logged fault



- The logged faults of the MCU, engine ECM or air conditioner can be deleted by this menu.

④ Monitoring

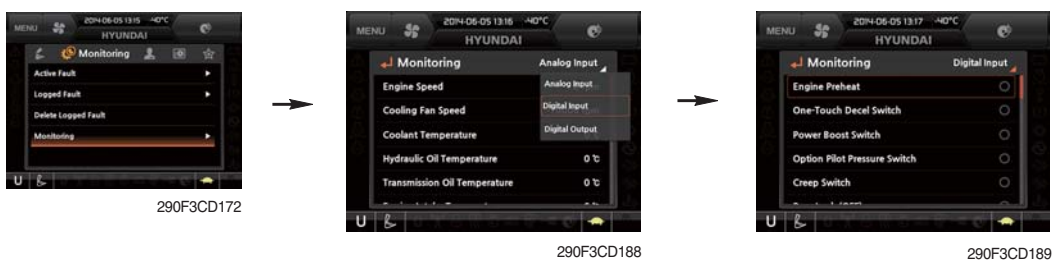

- The machine status such as the engine rpm, oil temperature, voltage and pressure etc. can be checked by this menu (Analog input).
- The switch status or output status can be confirmed by this menu (Digital input & Digital output).
- The activated switch or output pilot lamps ● are light ON.

(4) Management

① Fuel rate information



210WF3CD14



210WF3CD15

A



· General record (A)

- Average fuel rate (left) (from "Reset" to now)
Fuel consumption divided by engine run time (service meter time).
- A days fuel used (right)
Fuel consumption from 24:00 (or "Reset" time) to now (MCU real time).

B



· Hourly record (B)

- Hourly fuel rates for past 12 hours (service meter time).
- No record during key-off time.
- One step shift to the right for every one hour.
- Automatic deletion for 12 hours earlier data.
- All hourly records deletion by "Reset".

C



· Daily record (C)

- Daily fuel consumption for past seven days (MCU real time).
- No record during key-off time.
- One step shift to the right at 24:00 for every day.
- Automatic deletion for 7 days earlier data.
- All daily records deletion by "Reset".

D



· Mode record (D)

- Average fuel rate for each power mode/accl dial (at least 7) from "Reset" to now.
- No record during idle.
- All mode records deletion by "Reset".

210WF3CD16

② Maintenance information



210WF3CD131



290F3CD132



290F3CD133

- Alarm lamp (●) is ON when oil or filter needs to be changed or replaced.
- Replacement : The elapsed time will be reset to zero (0).
- Change interval : The change or replace interval can be changed in the unit of 50 hours.
- **Change or replace interval**

| No | Item | Interval |
|----|----------------------------------|----------|
| 1 | Engine oil | 500 |
| 2 | Final gear oil | 1000 |
| 3 | Swing gear oil | 1000 |
| 4 | Hydraulic oil | 5000 |
| 5 | Pilot line filter | 1000 |
| 6 | Drain filter | 1000 |
| 7 | Hydraulic oil return filter | 1000 |
| 8 | Engine oil filter | 500 |
| 9 | Fuel filter | 1000 |
| 10 | Fuel tank breather filter | 4000 |
| 11 | Pre-filter | 1000 |
| 12 | Hydraulic tank breather | 1000 |
| 13 | Air cleaner (inner & outer) | 4000 |
| 14 | Radiator coolant | 2000 |
| 15 | Swing gear pinion grease | 1000 |
| 16 | DEF/AdBlue® supply module filter | 1000 |

③ Machine security

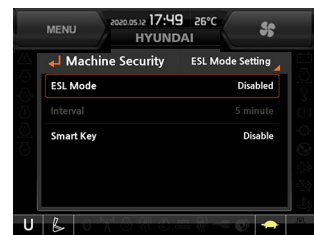

· ESL mode setting

- ESL : Engine Starting Limit
- ESL mode is designed to be a theft deterrent or will prevent the unauthorized operation of the machine.
- When you Enable the ESL mode, the password will be required when the starting switch is turned to the on position.

- Machine security

Disable : ESL function is disabled and password is not required to start engine.

Enable (always) : The password is required whenever the operator starts engine.

- **Interval** : The password is required when the operator starts engine first. But the operator can restart the engine within the interval time without inputting the password. The interval time can be set to a maximum 4 hours.

※ Default password : 00000 +

※ Password length : (5~10 digits) +

- Smart key (option) : Refer to next page.



· Password change

- The password is 5~10 digits.



Enter the current password



Enter the new password again



Enter the new password

※ Before first use, please set user password and owner password in advance for machine security.

- Smart key

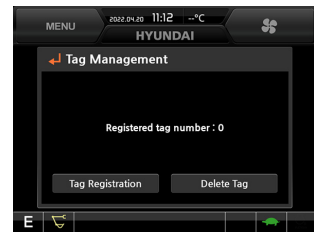
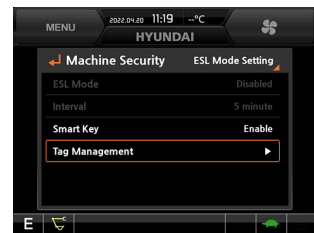
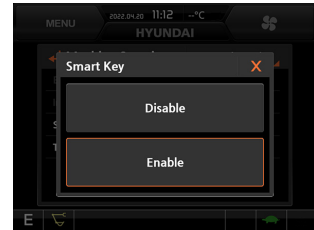
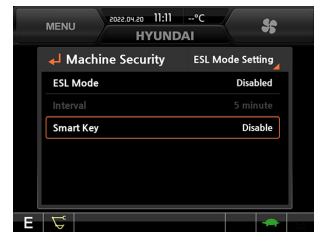

Deleting

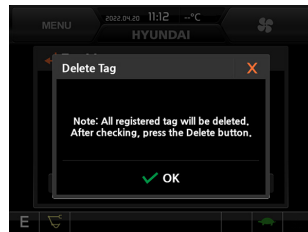

Registering

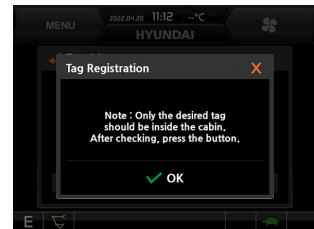

- Smart key is registered when equipped with optional smart key. If smart key is not inside of the cabin, authentication process fails and the password is needed.
- Tag management menu is activated when the Smart key menu is Enabled.
You can register and delete the tags.

- Tag management

- When registering a tag : Only the tag you want to register must be in the cabin.
- When deleting a tag : All registered tags are deleted.

④ Machine Information

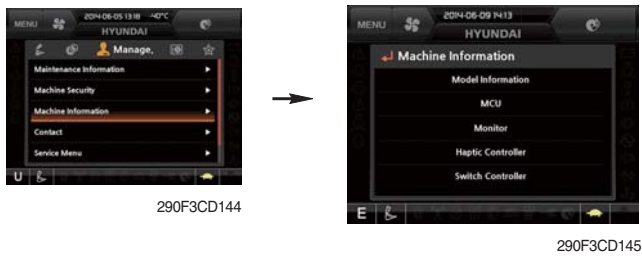

- This can confirm the identification of the model information (ECU), MCU, monitor, haptic controller, switch controller, RMCU, relay driver unit, FATC (air conditioner controller), AAVM (opt).

⑤ Contact (A/S phone number)

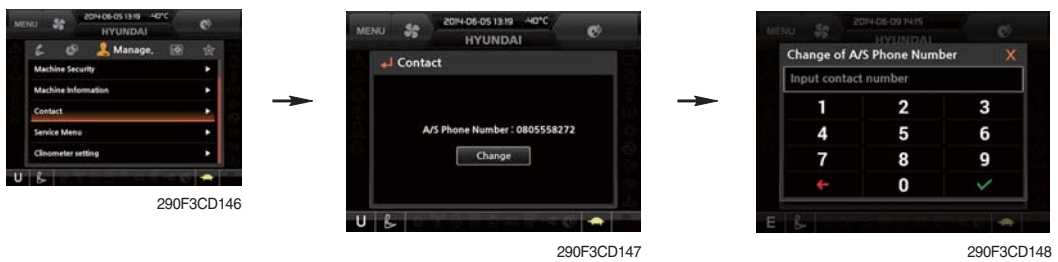

Enter the new A/S phone number

⑥ Clinometer

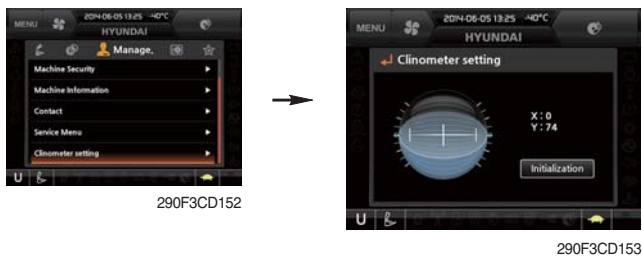

- When the machine is on the flatland, if tap the "initialization", the values of X, Y reset "0".
- You can confirm tilt of machine in cluster's operating screen.

⑦ Update (cluster & ETC devices)

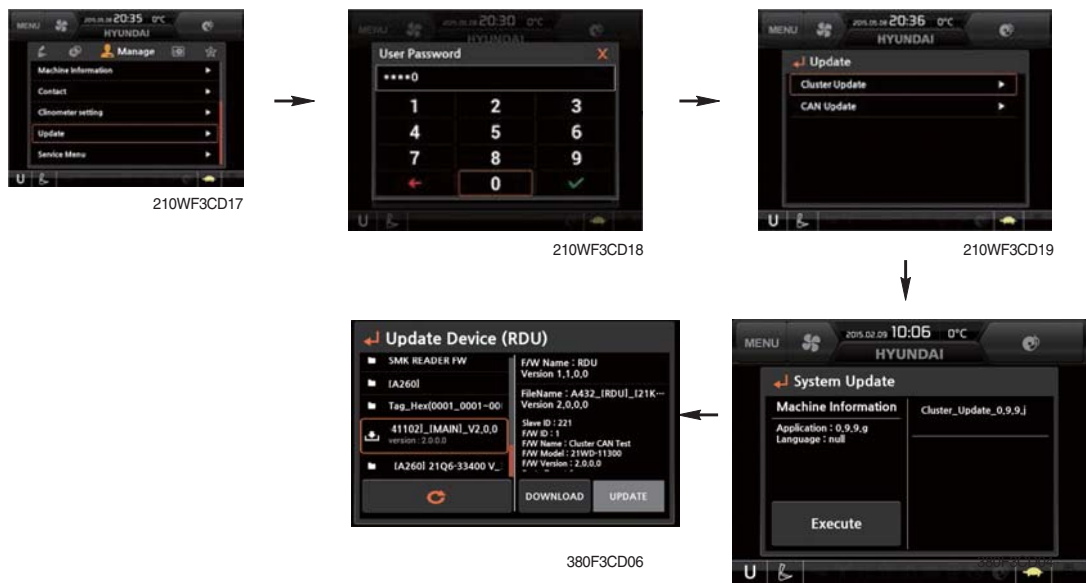

- ETC devices and cluster can be updated through CAN 2 network.
- Insert USB memory stick which includes program files, start download.

⑧ Service menu



- Power shift (standard/option) : Power shift pressure can be set by option menu.
- Operating hours : Operating hours since the machine line out can be checked by this menu.
- IPC mode : IPC mode 1, IPC mode 2, Not used.
- Breaker mode pump acting (1 pump/2 pump)
- EPPR current level (attach flow EPPR 1 & 2, boom priority EPPR, attach relief pressure EPPR 1 & 2)
- Overload pressure : 100 ~ 350 bar

(5) Display

① Display item



- The center display type of the LCD can be selected by this menu.
- The engine speed or each of the tripmeter (A,B,C) is displayed on the center display.

② Clock



- The first line's three spots "**/**/****" represent Month/Day/Year each.
- The second line shows the current time. (0:00~23:59)

③ Brightness



- If "Auto" is chosen, brightness for day and night can be differently set up. Also by using the bar in lower side, users can define which time interval belongs to day and night. (in bar figure, white area represents night time while orange shows day time)

④ Unit



290F3CD161



210WF3CD162



290F3CD193

- Temperature : °C ↔ °F
- Pressure : bar ↔ MPa ↔ kgf/cm²
- Volume : ℓ ↔ gal
- Flow : lpm ↔ gpm
- Distance : km ↔ mile
- Date format : yy/mm/dd ↔ mm/dd/yy ↔ dd-mm-yy

⑤ Language



290F3CD163



290F3CD164

- User can select preferable language and all displays are changed the selected language.

⑥ Screen type



290F3CD165



A Type (Default)

290F3CD166



290F3CD156A



B Type (Option)

290F3CD194



290F3CD167A

(6) Utilities

① Entertainment



290F3CD195



290F3CD196

A



210WF3CD219



290F3CD197

B



210WF3CD220



290F3CD198

C



210WF3CD199



210WF3CD22

- Video (A) : This menu operates the video play function.
mp4, mkv, avi files and so on.
- Audio (B) : This menu operates the play music.
mp3, mp4 files and so on.
- Smart terminal (C) : The menu features a smartphone and operates the miracast.

② Tripmeter



290F3CD168



290F3CD169

- Maximum 3 kinds of tripmeters can be used at the same time.
- Each tripmeter can be turned on by choosing "Start" while it also can be turned off by choosing "Stop".
- If the tripmeter icon is activated in the operation screen, it can be controlled directly there.

③ Camera setting

- If the rear camera is not installed on the machine, set disable.
- If the rear camera installed on the machine, set enable.



290F3CD200



290F3CD255



290F3CD256

- In the operation screen, rear camera screen show up when ESC/CAM button is pushed.



290F3CD156



290F3CD221

④ **AAVM** (All Around View Monitoring, option)

- The AAVM buttons of the cluster consist of ESC/CAM and AUTO IDLE/Buzzer stop.



- **Escape button**

- It will enter into the AAVM mode from the beginning screen if the AAVM is installed.
- While in the AAVM mode, select the ESC button to return to the beginning screen.



- **Buzzer stop button**

- In AAVM mode, it detects surrounding pedestrians or objects and the warning buzzer sounds.
- User can turn OFF the warning sound by pressing buzzer stop button.



- When the worker or pedestrian go to the blue line (radius 5 m), an external danger area of equipping on the cluster screen, the warning buzzer sounds and it displays the blue rectangular box for the recognition of the worker and pedestrian. At this time, the operator should stop work immediately, and stop the buzzer by pressing the buzzer stop button. And then, please work after you check whether the danger factors are solved.



- When the worker or pedestrian go inside of red line (radius 3 m), an internal danger area of equipping on the cluster screen, the warning buzzer sounds and it displays the red rectangular box for the recognition of the worker and pedestrian. At this time, the operator should stop work immediately, and stop the buzzer by pressing the buzzer stop button. And then, please work after you check whether the danger factors are solved.

※ In AAVM mode, a touch screen of the LCD is available only. The multimodal dial of the haptic controller is not available.

7) AIR CONDITIONER AND HEATER

Full auto air conditioner and heater system automatically keeps the optimum condition in accordance with operator's temperature configuration sensing ambient and cabin inside temperature.

· Location of air flow ducts

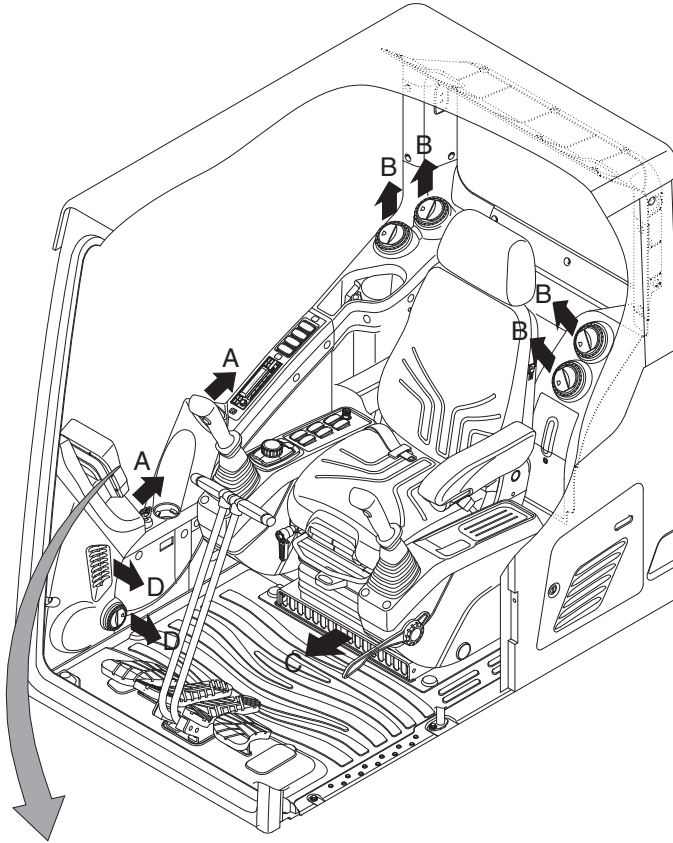

Cluster LCD



Cluster :  or
Haptic controller : 

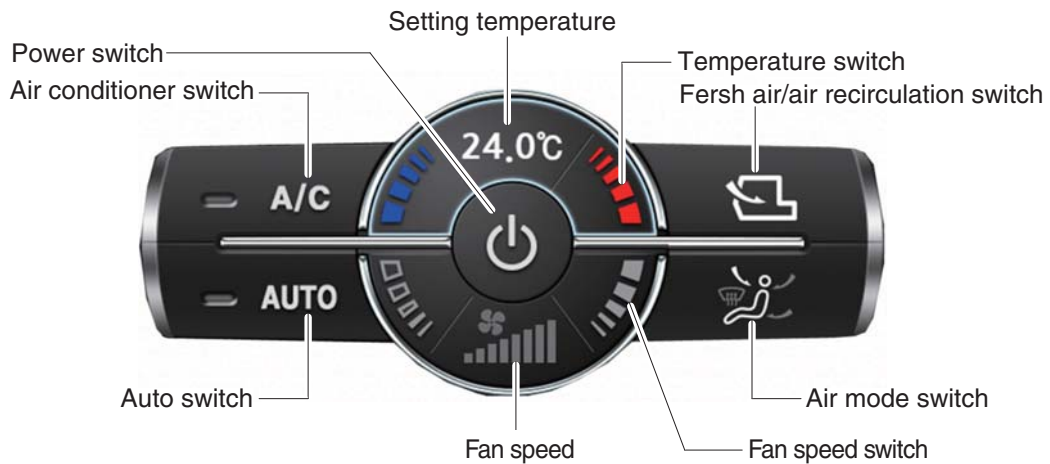

※ Haptic controller : Refer to operator's manual page 3-57.

290F3CD201

(1) Power switch



- ① This switch makes the system ON/OFF.
Just before the power OFF, set values are stored.
- ② Default setting values

| Function | Air conditioner | In/outlet | LCD | Temperature | Mode |
|----------|-----------------|-----------|-----|-----------------|-----------------|
| Value | OFF | Inlet | OFF | Previous sw OFF | Previous sw OFF |

(2) Air conditioner switch



- ① This switch turns the compressor ON/OFF.
- ※ **Air conditioner operates to remove vapor and drains water through a drain hose. Water can be sprayed into the cab in case that the drain cock at the ending point of drain hose has a problem.**
In this case, exchange the drain cock.

(3) Auto switch



- ① Auto air conditioner and heater system automatically keeps the optimum condition in accordance with operator's temperature configuration sensing ambient and cabin inside temperature.

(4) Setting temperature



- ① Display the temperature setting out.

(5) Temperature switch

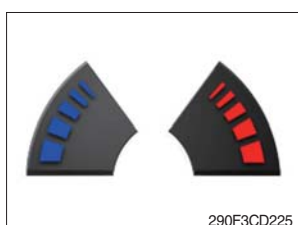

- ① Setting temperature indication
· Lo (17°C), 17.5~31.5°C, Hi (32°C)
- ② Max cool and max warm beeps 5 times.
- ③ The max cool or the max warm position operates as following table.

| Temperature | Compressor | Fan speed | In/outlet | Mode |
|-------------|------------|-------------|---------------|----------|
| Max cool | ON | Hi (8 step) | Recirculation | Face |
| Max warm | OFF | Hi (7 step) | Fresh | Def/Foot |

- ④ Temperature unit can be changed between celsius (°C) and fahrenheit (°F)
 - a. Default status (°C)
 - b. Push Up/Down temperature switch simultaneously more than 5 second displayed temperature unit change (°C → °F)

(6) Fan speed switch

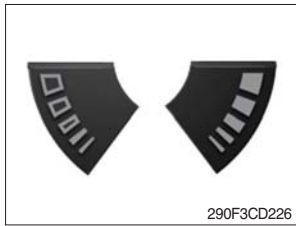

- ① Fan speed is controlled automatically by setted temperature.
- ② This switch controls fan speed manually.
 - There are 8 up/down steps to control fan speed.
 - The maximum step or the minimum step beeps 5 times.

(7) Fan speed

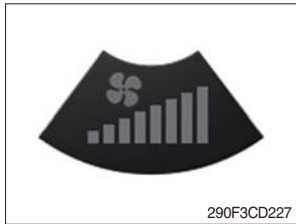

- ① Steps 1 through 8 to display the amount of wind.

(8) Fresh air/air recirculation switch



- ① It is possible to change the air-inlet method.
 - a. **Fresh air** (☞)
 - Inhaling air from the outside.
 - b. **Air recirculation** (☞)
 - It recycles the heated or cooled air to increase the energy efficiency.
- ※ **Change air occasionally when using recirculation for a long time.**
- ※ **Check out the fresh air filter and the recirculation filter periodically to keep a good efficiency.**

(9) Air mode switch



- ① Operating this switch, it beeps and displays symbol of each mode in order. (Face → Face/Rear → Face/Rear/Foot → Foot → Def/Foot)

| Mode switch | | Face | Face/Rear | Face/Rear/Foot | Foot | Def/Foot |
|-------------|---|------|-----------|----------------|------|----------|
| | | | | | | |
| Outlet | A | ● | ● | ● | | |
| | B | | ● | ● | | |
| | C | | | ● | ● | ● |
| | D | | | | | ● |

- ② When defroster mode operating, FRESH AIR/AIR RECIRCULATION switch turns to FRESH AIR mode and air conditioner switch turns ON.

8) SELF DIAGNOSIS FUNCTION

(1) Diagnostic methods : Diagnostic information window, select

(2) Diagnostic indication (Displays fault)

| Fault code | Description | Fail safe function |
|------------|--|--|
| F01 | Ambient temperature sensor open | 20°C alternate value control |
| F02 | Ambient temperature sensor short | |
| F03 | Cab inside temperature sensor open | 25°C alternate value control |
| F04 | Cab inside temperature sensor short | |
| F05 | Evaporate temperature sensor open | 0°C alternate value control |
| F06 | Evaporate temperature sensor short | |
| F07 | Null | - |
| F08 | Null | - |
| F09 | Mode 1 actuator open/short | The alternate value is face |
| F10 | Mode 1 actuator drive circuit malfunction | If not, the alternate value is Def/Foot |
| F11 | Intake actuator open/short | The alternate value is air recirculation |
| F12 | Intake actuator drive circuit malfunction | The alternate fresh air |
| F13 | Temperature actuator open/short | If opening amount is 0 %, the alternate value is 0 % |
| F14 | Temperature actuator drive circuit malfunction | If not, the alternate value is 100 % |
| F15 | Null | - |
| F16 | Null | - |

GROUP 15 FUEL WARMER SYSTEM

1. SPECIFICATION

- 1) Operating voltage : 24 ± 4 V
- 2) Power : 350 ± 50 W
- 3) Current : 15 A

2. OPERATION

- 1) The current of fuel warmer system is automatically controlled without thermostat according to fuel temperature.
 - 2) At the first state, the 15 A current flows to the fuel warmer and engine may be started in 1~2 minutes.
 - 3) If the fuel starts to flow, ceramic-disk in the fuel warmer heater senses the fuel temperature to reduce the current as low as 1.5 A.
- So, fuel is protected from overheating by this mechanism.

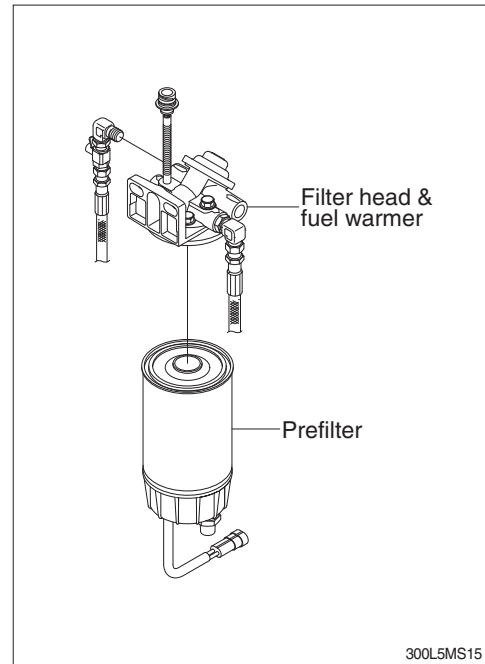

300L5MS15

3. ELECTRIC CIRCUIT

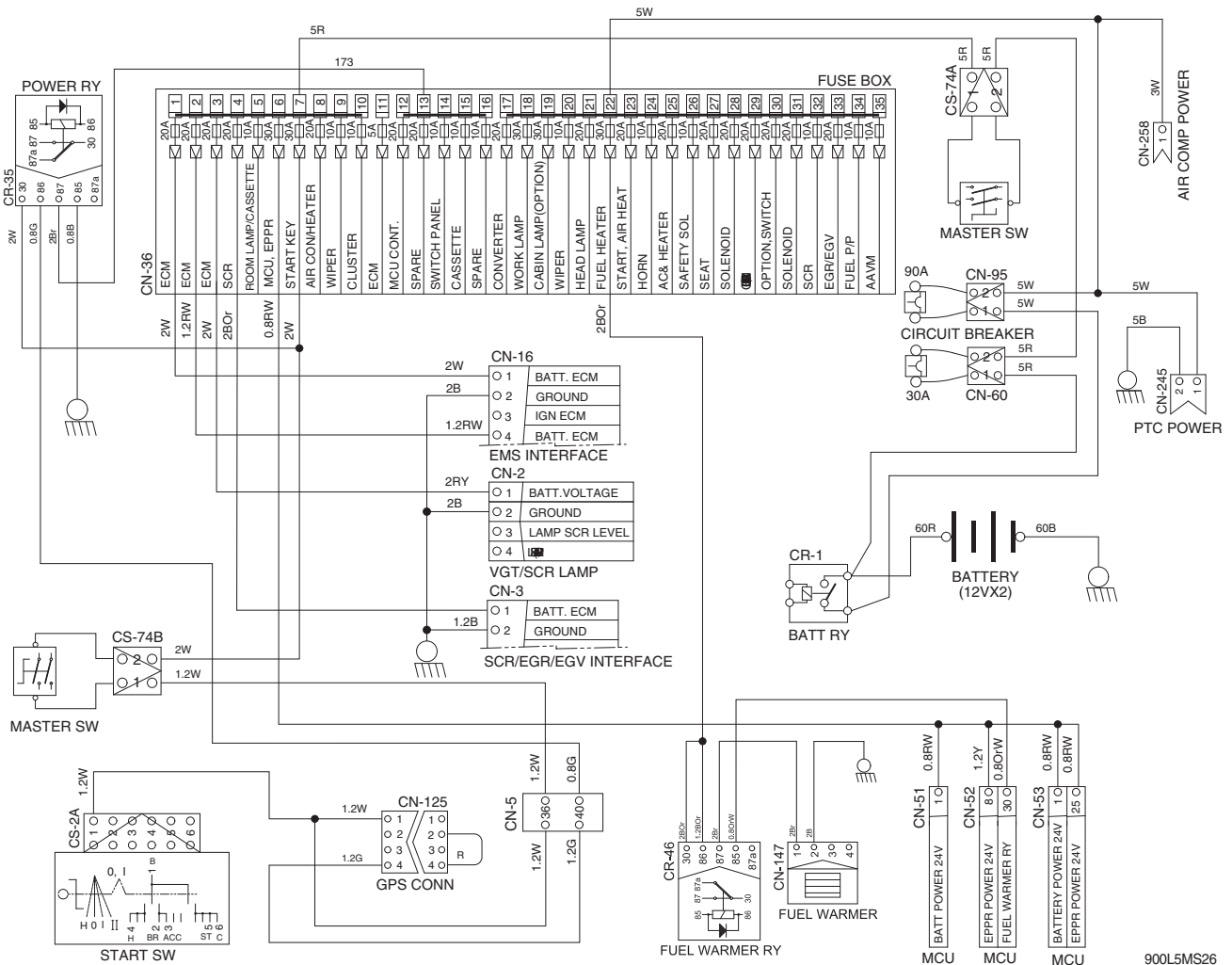

900L5MS26