

SECTION 2 STRUCTURE AND FUNCTION

Group 1 Pump Device	2-1
Group 2 Main Control Valve	2-5
Group 3 Swing Device	2-7
Group 4 Travel Device	2-17

SECTION 2 STRUCTURE AND FUNCTION

GROUP 1 HYDRAULIC PUMP

1. STRUCTURE (1/2)

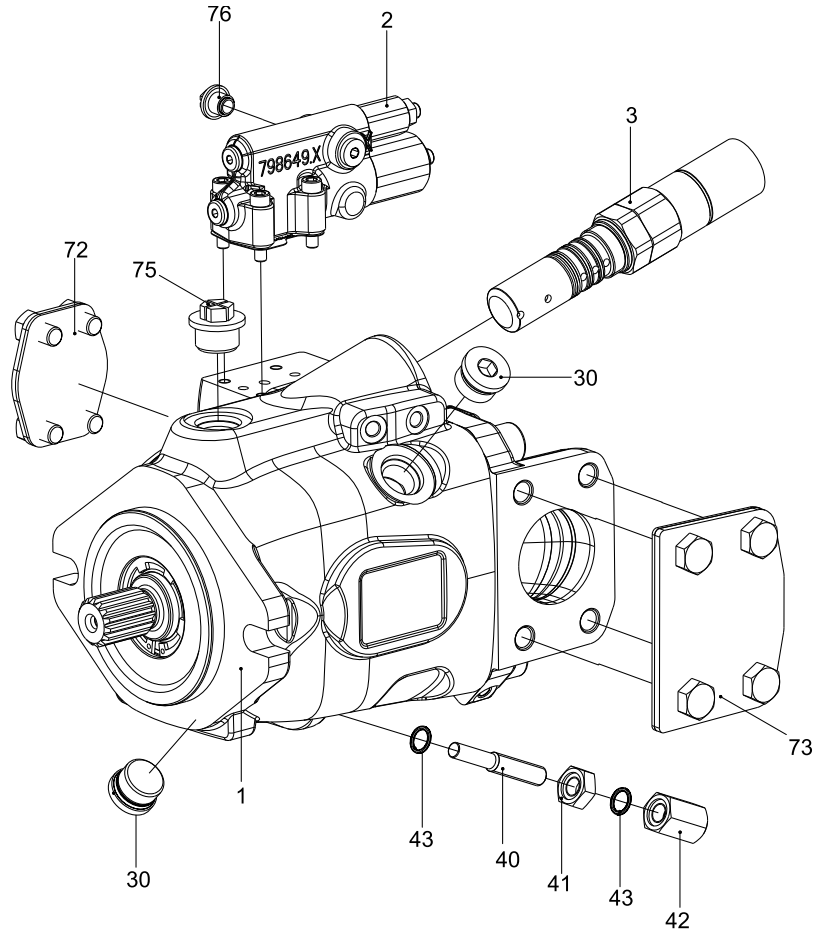

60S2MP05

- | | | | |
|----|---------------|----|--------|
| 1 | Main pump | 43 | O-ring |
| 2 | Control valve | 72 | Cover |
| 3 | Control valve | 73 | Cover |
| 30 | Locking screw | 75 | Screw |
| 40 | Stop screw | 76 | Screw |
| 41 | Nut | | |
| 42 | Cap | | |

STRUCTURE (2/2)

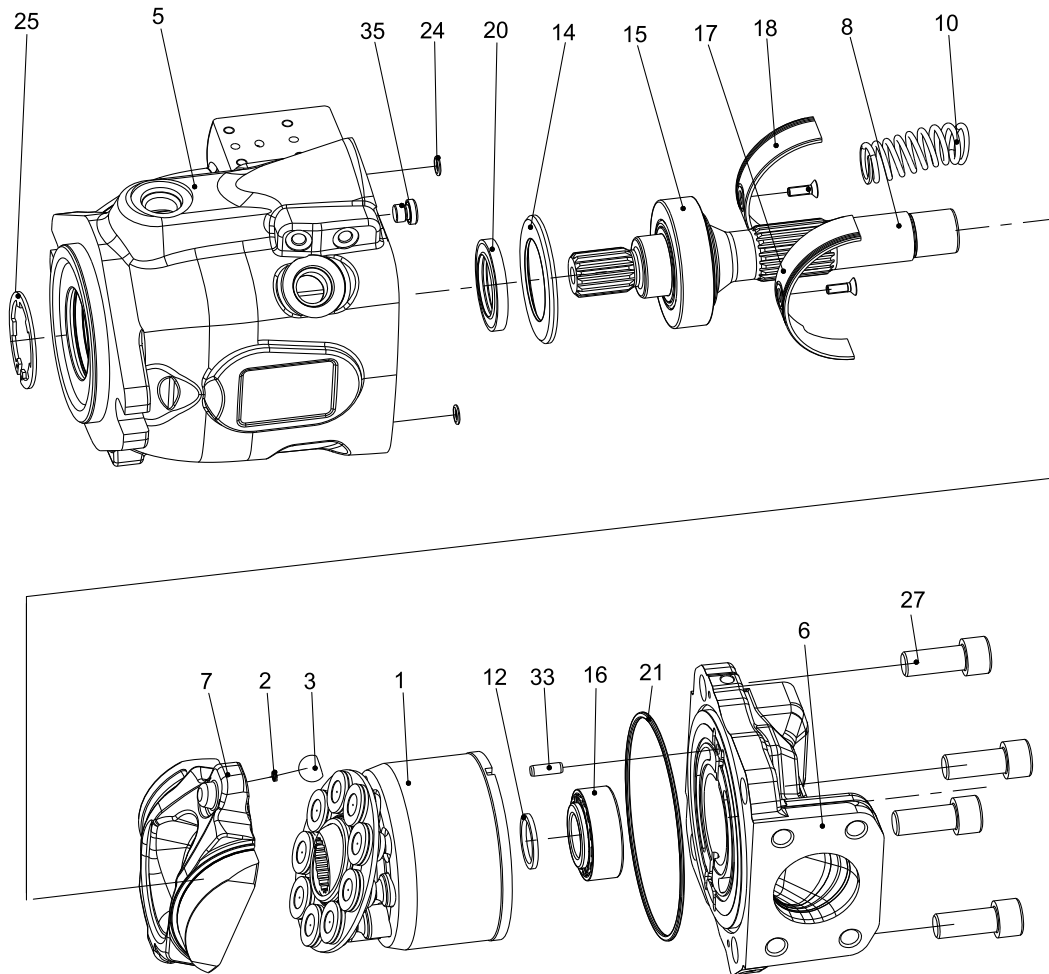

- | | | | |
|----|----------------------|----|----------------------|
| 1 | Rotary Assy | 16 | Taper roller bearing |
| 2 | Spring | 17 | Liner bearing |
| 3 | Stopper | 18 | Liner bearing |
| 5 | Pump housing | 20 | Seal ring |
| 6 | Port plate | 21 | O-ring |
| 7 | Swash plate | 24 | Seal ring |
| 8 | Drive shaft | 25 | Retainer ring |
| 10 | Spring | 27 | Socket screw |
| 12 | Adjust shim | 33 | Cylinder pin |
| 14 | Stop ring | 35 | Screw |
| 15 | Taper roller bearing | | |

60S2MP05

2. PUMP FUNCTIONS

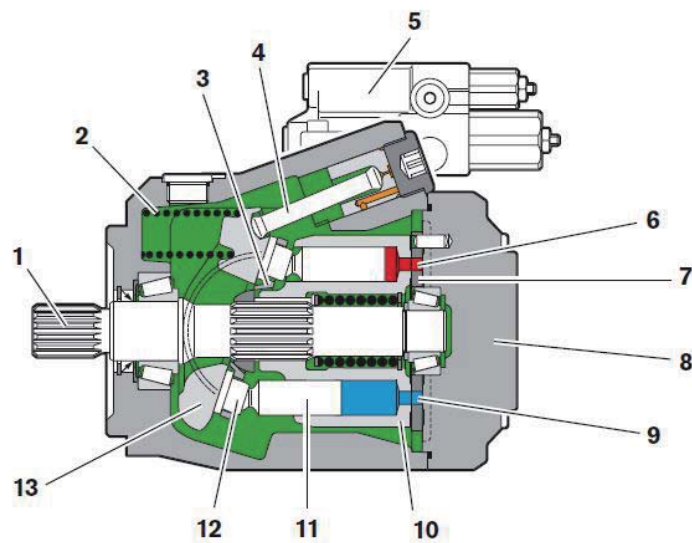

HX60S2MP01

- | | | | |
|---|--------------------|----|--------------|
| 1 | Drive shaft | 8 | Port plate |
| 2 | Spring | 9 | Suction side |
| 3 | Retaining plate | 10 | Cylinder |
| 4 | Stroke piston | 11 | Piston |
| 5 | Control valve | 12 | Slipper pad |
| 6 | High-pressure side | 13 | Swashplate |
| 7 | Control plate | | |

Torque and rotational speed are applied to the drive shaft (1) by an engine. The drive shaft is connected by splines to the cylinder (10) to set this in motion. With every revolution, the pistons (11) in the cylinder bores execute one stroke whose magnitude depends on the setting of the swashplate (13). The pistons hold the slipper pads (12) onto the glide surface of the swashplate with the retaining plate (3) and guide them along. The swashplate setting during a rotation causes each piston to move over the bottom and top dead centers and back to its initial position. Here, hydraulic fluid is fed in and drained out through the two control slots in the control plate (7) according to the stroke displacement. On the suction side (9) hydraulic fluid flows into the piston chamber as the piston recedes. At the same time, on the high-pressure side (6) the fluid is pushed out of the cylinder chamber into the hydraulic system by the pistons.

3. CONTROL FUNCTIONS

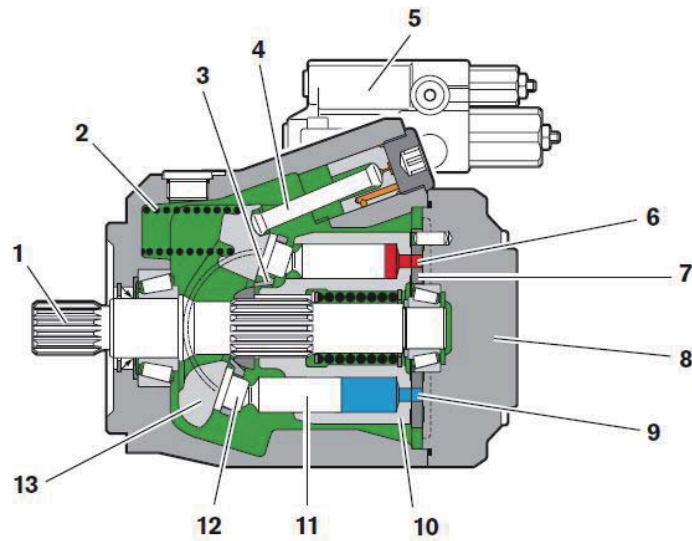

HX60S2MP01

- | | | | |
|---|--------------------|----|--------------|
| 1 | Drive shaft | 8 | Port plate |
| 2 | Spring | 9 | Suction side |
| 3 | Retaining plate | 10 | Cylinder |
| 4 | Stroke piston | 11 | Piston |
| 5 | Control valve | 12 | Slipper pad |
| 6 | High-pressure side | 13 | Swashplate |
| 7 | Control plate | | |

The swivel angle of the swashplate (13) is steplessly variable. Controlling the swivel angle of the swashplate changes the piston stroke and therefore the displacement. The swivel angle is changed hydraulically by means of the stroke piston. The swashplate is mounted in swivel bearings for easy motion and it is kept in balance by a spring (2). Increasing the swivel angle increases the displacement; reducing the angle results in a corresponding reduction in displacement.

GROUP 2 MAIN CONTROL VALVE

1. OUTLINE

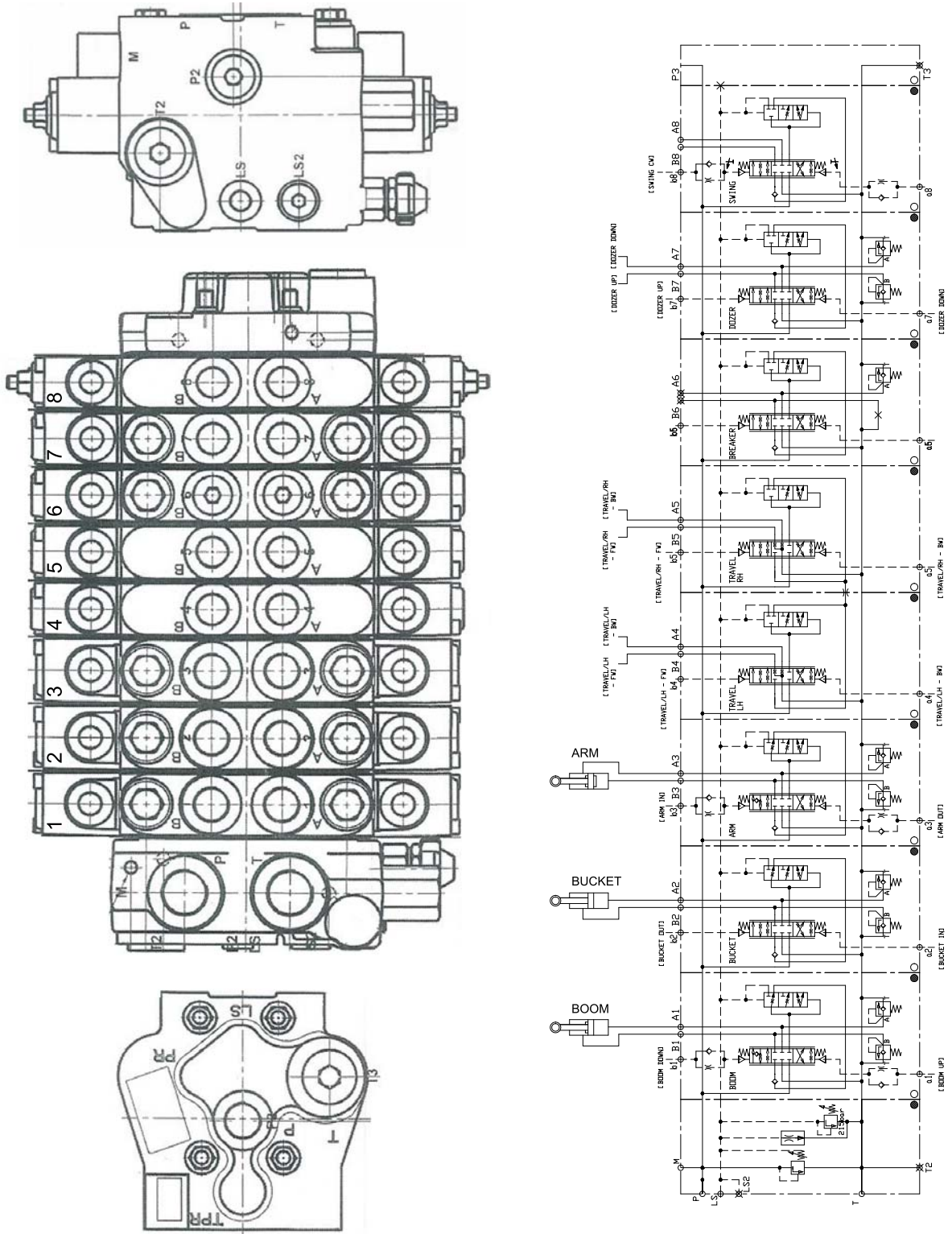

P, T : PF 3/4
 LS, M, a, b : PF 1/4
 A, B : PF 3/8

60S2MC01

2. SECTION FUNCTIONAL DESCRIPTION

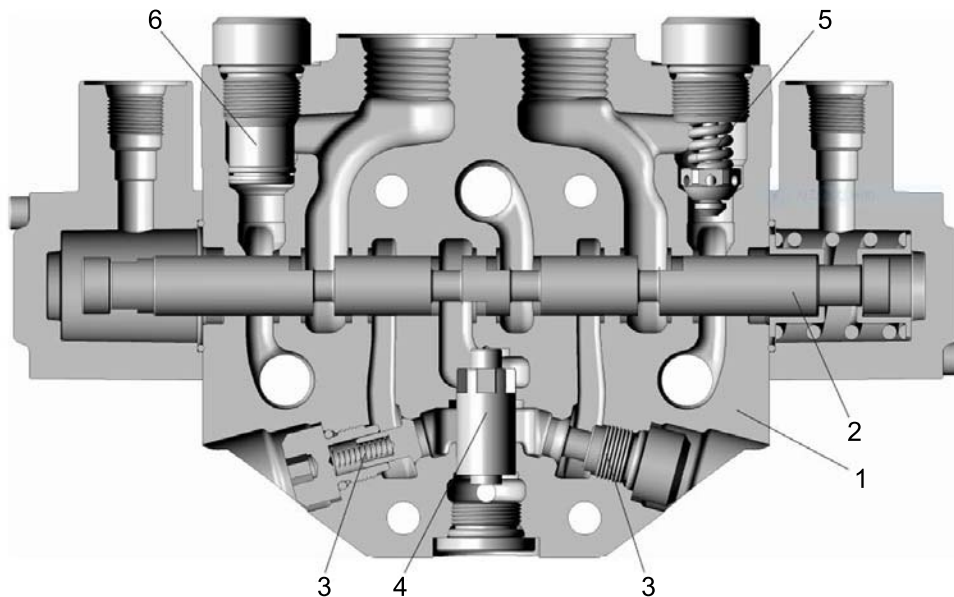

1	Housing	4	Pressure compensator
2	Main spool	5	Secondary valve
3	Load holding valves	6	Plug screw

60S2MC02

- The control block consists of an inlet plate, elements and an end plate. The inlet plate has two mounting points as well as the line connections P, T, LS and M. The inlet plate moreover comprises all components necessary for the system function: One flow control valve for the controlled unloading of the LS line and one LS pressure relief valve to limit the maximum system pressure.
- Every directional valve element of the control block consists of the housing (1), one main spool (2), two load holding valves (3), one pressure compensator (4), installation bores for direct operated pressure relief valves with feed function (5) as well as feed valves or plug screws (6). The end plate has two mounting points.

GROUP 3 SWING DEVICE

1. STRUCTURE

Swing device consists swing motor, swing reduction gear.

1) SWING MOTOR

Swing motor include mechanical parking valve, relief valve, make up valve and time delay valve.

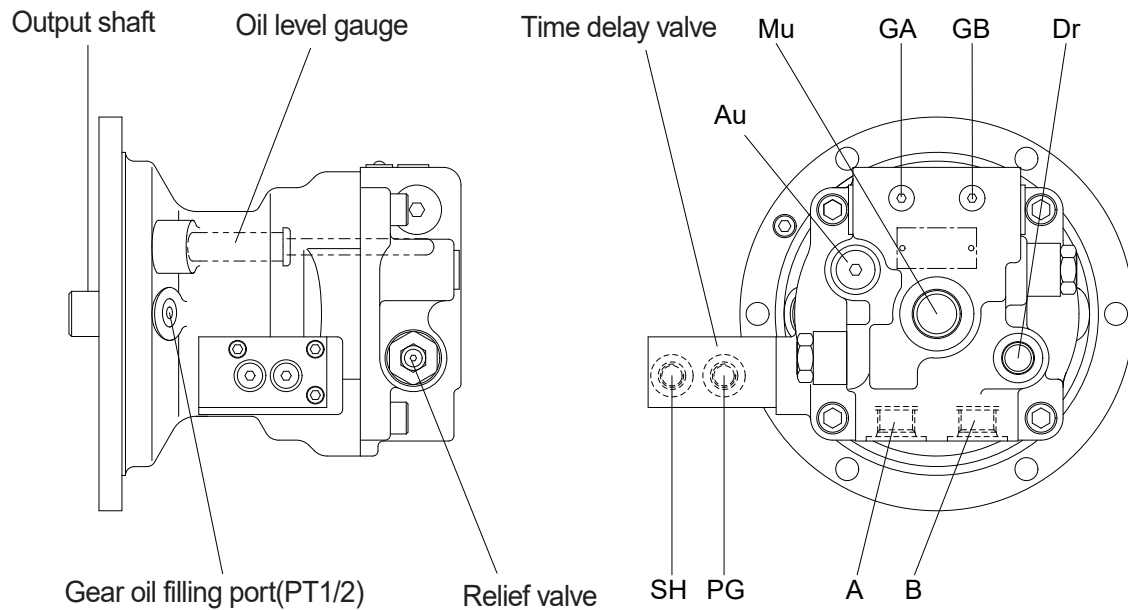

HX60A2SM01

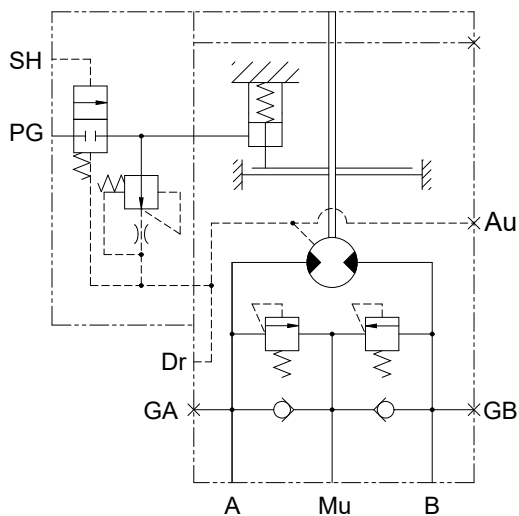

Hydraulic circuit

Port	Port name	Port size
A	Main port	PF 1/2
B	Main port	PF 1/2
Dr	Drain port	PF 3/8
Mu	Make up port	PF 3/4
PG	Brake release stand by port	PF 1/4
SH	Brake release pilot port	PF 1/4
AU	Air vent port	PF 3/8
GA,GB	Gauge port	PF 1/4

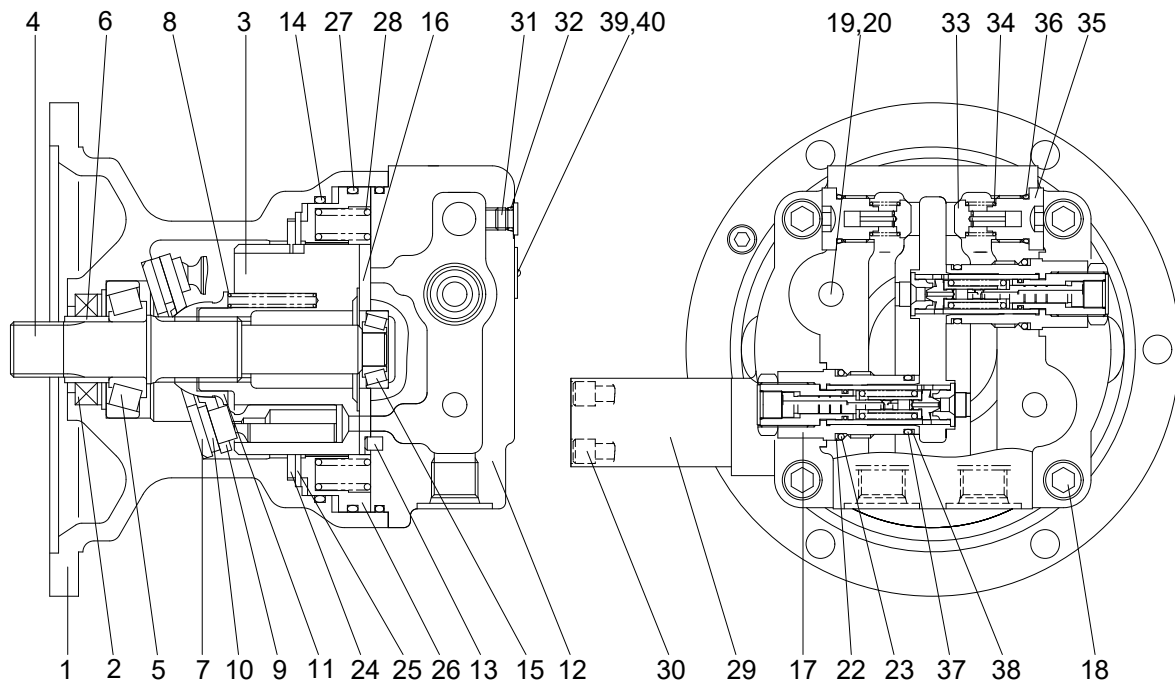

HX60A2SM03

- | | | | | | |
|----|------------------|----|-------------------|----|------------------|
| 1 | Body | 14 | O-ring | 28 | Spring |
| 2 | Oil seal | 15 | Taper bearing | 29 | Time delay valve |
| 3 | Cylinder block | 16 | Valve plate | 30 | Socket bolt |
| 4 | Shaft | 17 | Relief valve assy | 31 | Plug |
| 5 | Taper bearing | 18 | Socket bolt | 32 | O-ring |
| 6 | Bushing | 19 | Plug | 33 | Valve |
| 7 | Shoe plate | 20 | O-ring | 34 | Spring |
| 8 | Spring | 22 | Back up ring | 35 | Plug |
| 9 | Set plate | 23 | O-ring | 36 | O-ring |
| 10 | Piston shoe assy | 24 | Friction plate | 37 | O-ring |
| 11 | Ball guide | 25 | Plate | 38 | Back up ring |
| 12 | Rear cover | 26 | Parking piston | 39 | Name plate |
| 13 | Pin | 27 | O-ring | 40 | Rivet |

2) REDUCTION GEAR

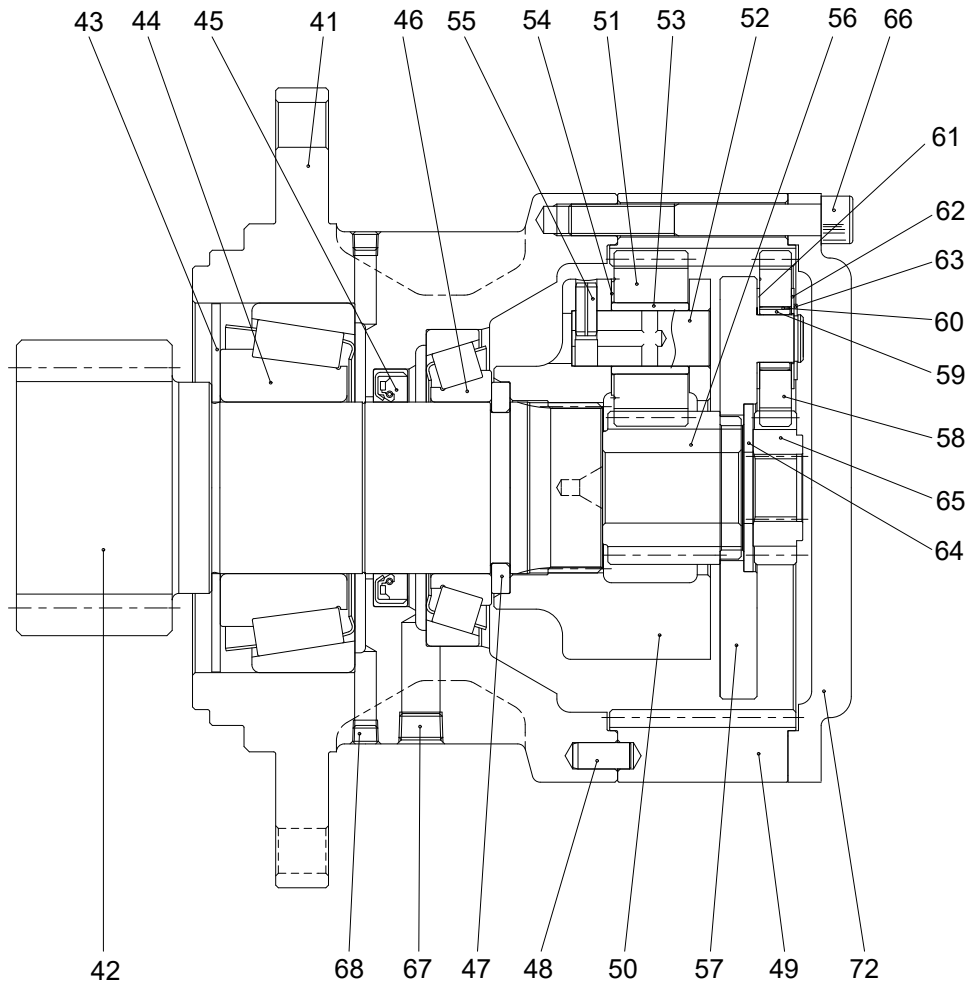

HX60A2SM02

41 Case	52 Pin 2	63 Snap ring
42 Pinion gear	53 Needle roller bearing	64 Side plate
43 Bearing cover	54 Thrust washer 2	65 Sun gear 1
44 Taper roller bearing	55 Spring pin	66 Bolt
45 Oil seal	56 Sun gear 2	67 Plug
46 Taper roller bearing	57 Carrier assy 1	68 Plug
47 Lock collar	58 Planet gear 1	69 Level bar
48 Knock pin	59 Needle roller bearing	70 Level pipe
49 Ring gear	60 Collar	71 Air breather
50 Carrier assy 2	61 Thrust washer 1	72 Cover
51 Planet gear 2	62 Thrust washer 2	

2. FUNCTION

1) ROTARY PART

When high pressurized oil enters a cylinder through port(a), which is the inlet of balance plate(16), hydraulic pressure acting on the piston causes axial force F. The pressure force F works via the piston(10) upon the return plate(9) which acts upon the swash plate(7) via an hydrostatic bearing. Force F1 perpendicular to swash plate(7) and force F2 perpendicular to cylinder center.

Being transferred to the cylinder block(3) through piston, force F2 causes rotational moment at surroundings of cylinder.

Since cylinder block has 9 equidistantly arrayed pistons, rotational torque is transmitted to cylinder shaft in order by several pistons connected to the inlet port of high pressurized oil. When the direction of oil flow is reversed, rotational direction of cylinder is also reversed. Output torque is given by the equation.

$$T = \frac{p \times q}{2\pi}, q = Z \cdot A \cdot \text{PCD} \cdot \tan \theta, F1 = \frac{F}{\cos \theta}, F2 = F \tan \theta, S = \text{PCD} \times \tan \theta$$

Where p : Effective difference of pressure (kgf/cm²)

q : Displacement (cc/rev)

T : Output torque (kgf · cm)

Z : Piston number (9EA)

A : Piston area (cm²)

θ : Tilting angle of swash plate (degree)

S : Piston stroke (cm)

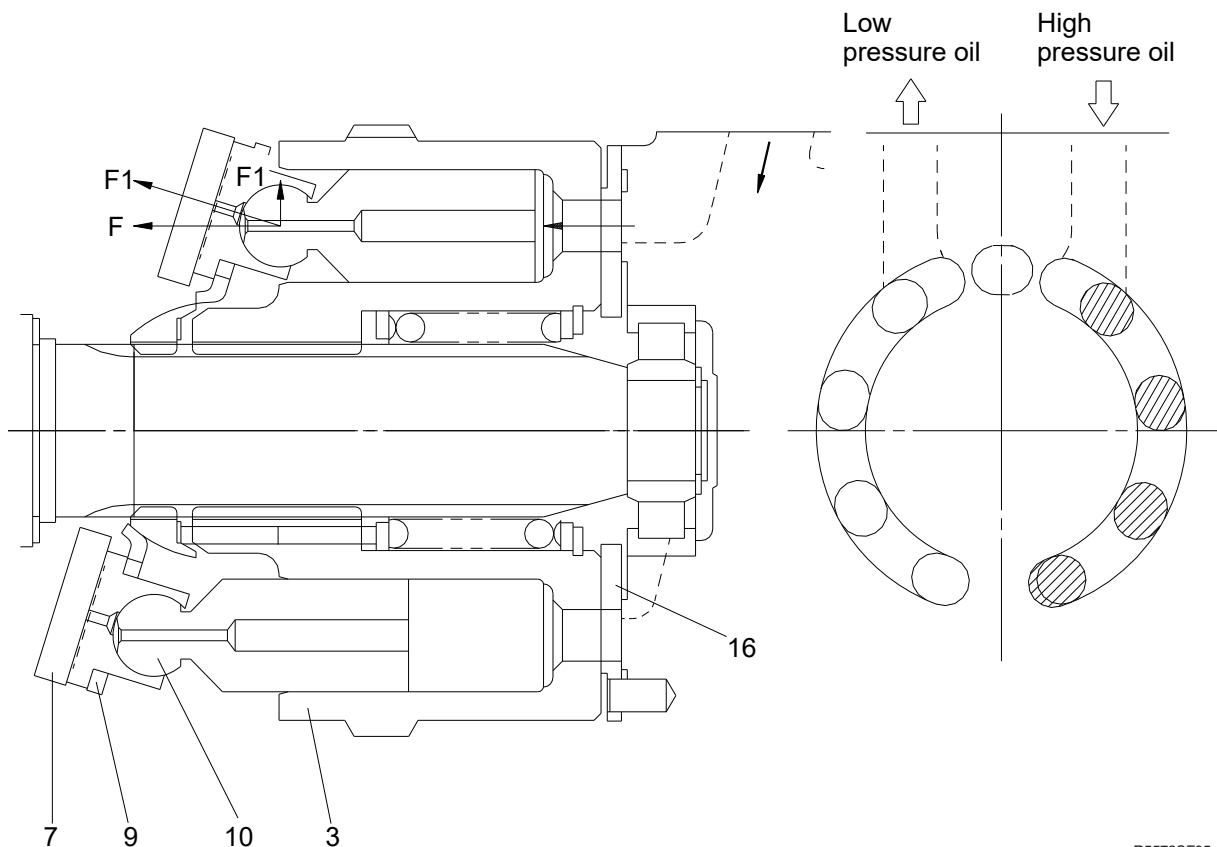

R5572SF35

2) MAKE UP VALVE

(1) Outline

The safety valve portion consists of a check valve and safety valve.

(2) Function

When the swing is stopped, the output circuit of the motor continues to rotate because of inertia. For this reason, the pressure at the output side of the motor becomes abnormally high, and this will damage the motor. To prevent this, the oil causing the abnormal hydraulic pressure is allowed to escape from the outlet port (high-pressure side) of the motor to port Mu, thereby preventing damage to the motor.

Compared with a counterbalance valve, there is no closed-in pressure generated at the outlet port side when slowing down the swing speed. This means that there is no vibration when slowing down, so the ease of swing control is improved.

(3) Operation

① When starting swing

When the swing control lever is operated to left swing, the pressurized oil from the pump passes through the control valves and is supplied to port B. Because of this, the pressure at port B rises, starting torque is generated in the motor, and the motor starts to rotate. The oil from the outlet port of the motor passes from port A through the control valve and returns to the tank.

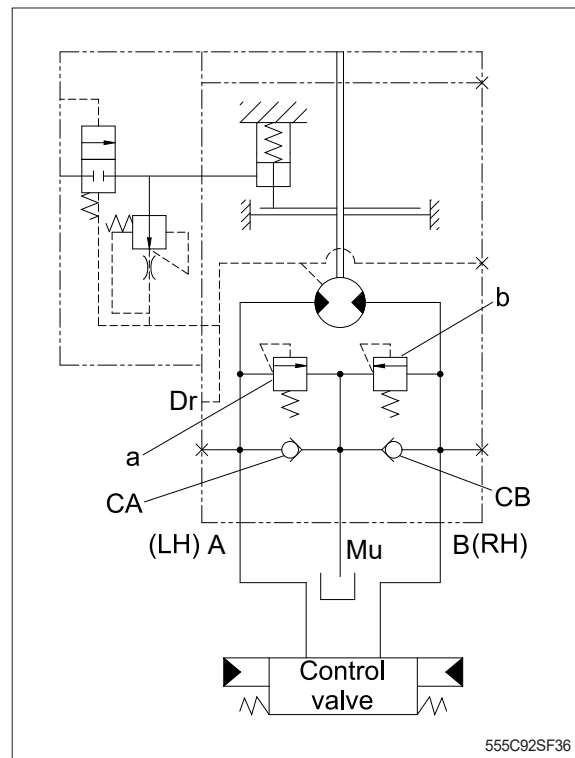

② When stopping swing

- When the swing control lever is returned to neutral, no pressurized oil is supplied from the pump to port B.

The return circuit to the tank is closed by the control valve. So the oil from the outlet port of the motor increases in pressure at port A. Resistance to the rotation of the motor is created, and the brake starts to act.

- The pressure at port A rises to the set pressure of make up valve a, and in this way, a high brake torque acts on the motor, and the motor stops.
- When make up valve a is being actuated, the relief oil from make up valve a and the oil from port Mu pass through check valve CB and are supplied to port B. This prevents cavitation from forming at port B.

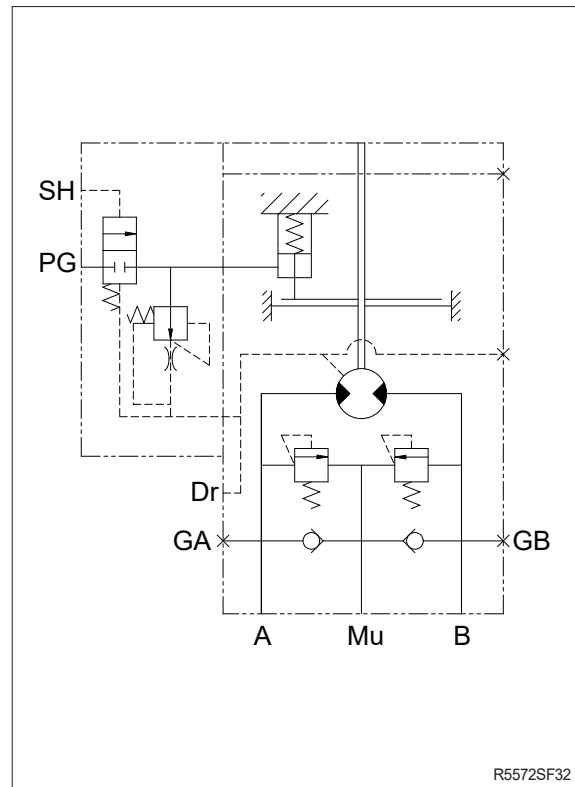

3) RELIEF VALVE

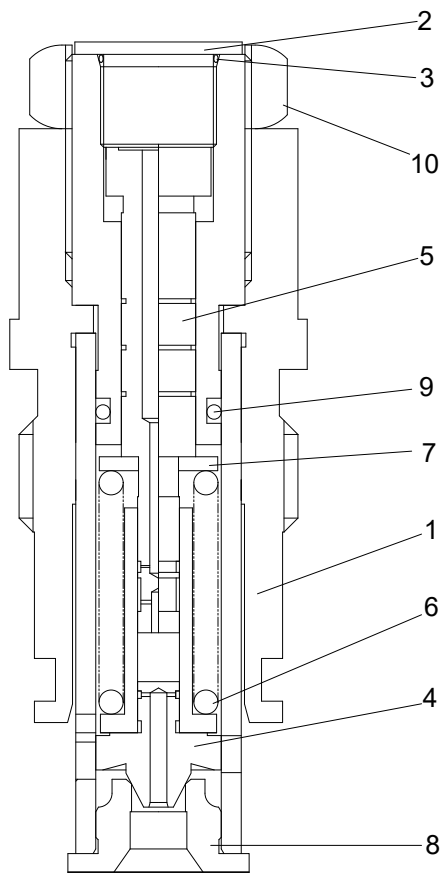

- 1 Body
- 2 Plug
- 3 O-ring
- 4 Plunger
- 5 Piston
- 6 Spring
- 7 Spring seat
- 8 Seat
- 9 O-ring
- 10 Nut

555C92SF37

(1) Construction of relief valve

The valve casing contains two cartridge type relief valves that stop the regular and reverse rotations of the hydraulic motor. The relief valves relieve high pressure at start or at stop of swing motion and can control the relief pressure in two steps, high and low, in order to insure smooth operation.

(2) Function of relief valve

Figure illustrates how the pressure acting on the relief valve is related to its rising process. Here is given the function, referring to the figure following page.

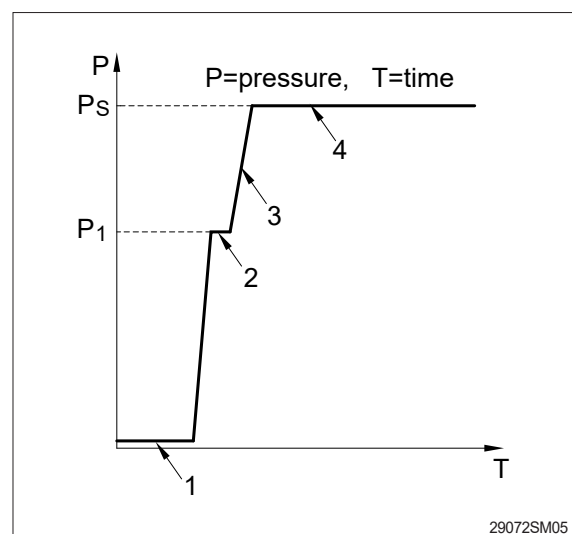

29072SM05

4) BRAKE SYSTEM

(1) Control valve swing brake system

This is the brake system to stop the swing motion of the excavator during operation.

In this system, the hydraulic circuit is throttled by the swing control valve, and the resistance created by this throttling works as a brake force to slow down the swing motion.

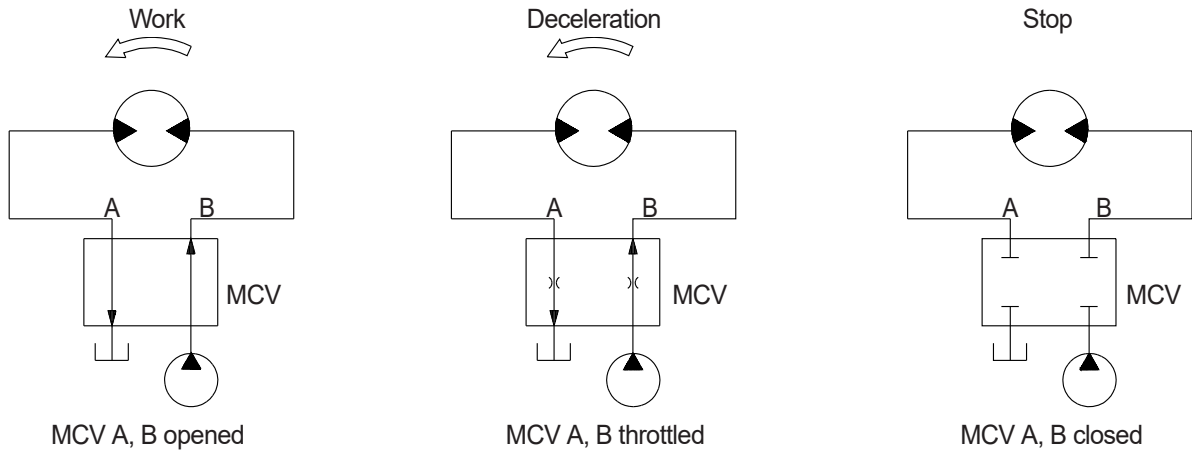

210-7 2-48(1)

(2) Mechanical swing parking brake system

The mechanical swing parking brake system is installed to prevent the upper structure from swinging downhill because of its own weight when the excavator is parked on a slope since it completely eliminates the hydraulic drift of swing motion while the excavator is on a slope, work can be done more easily and safely.

① Brake assembly

Circumferential rotation of separate plate (25) is constrained by the groove located at body (1). When housing is pressed down by brake spring (28) through friction plate (24), separate plate (25) and parking piston (26), friction force occurs there.

Cylinder block (3) is constrained by this friction force and brake acts, while brake releases when hydraulic force exceeds spring force.

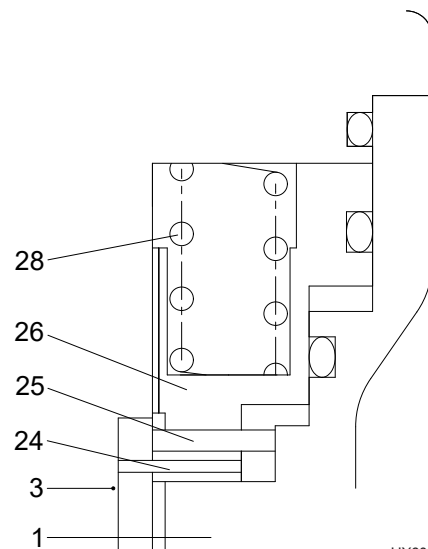

HX60A2SF38

1	Body	25	Separate plate
3	Cylinder block	26	Parking piston
24	Friction plate	28	Brake spring

② Operating principle

- a. When the swing control lever (1) is set to the swing position, the pilot oil goes to the swing control valve (2) and to SH of the time delay valve (3) via the shuttle valve (4), this pressure move spool (5) to the leftward against the force of the spring (8), so pilot pump charged oil (P4) goes to the chamber G.

This pressure is applied to move the piston (26) to the upward against the force of the spring (28). Thus, it releases the brake force.

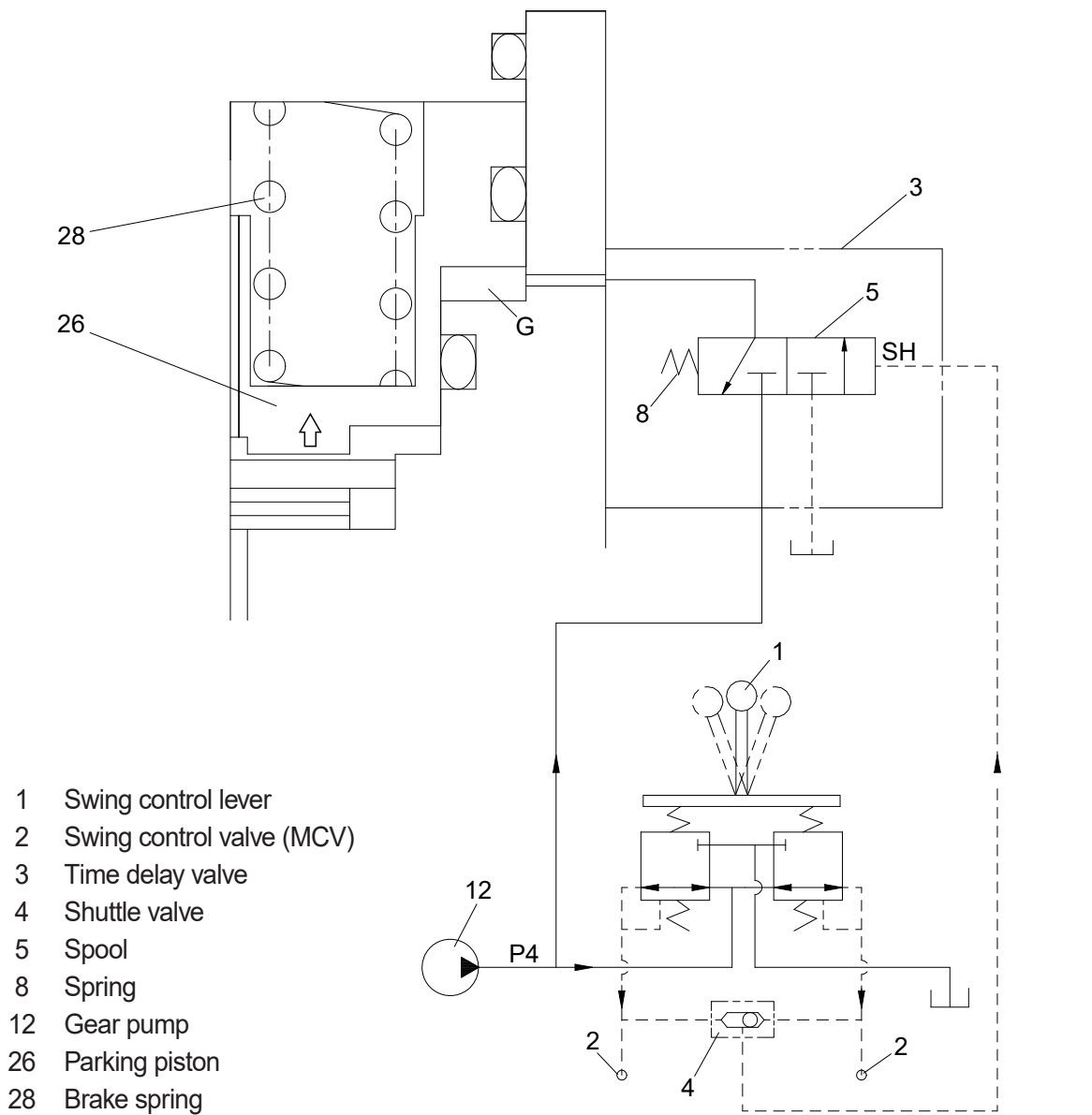

HX60A2SF39

- b. When the swing control lever (1) is set the neutral position, the time delay valve (3) shifts the neutral position and the pilot oil blocked chamber G.
- Then, the piston (26) is moved lower by spring (28) force and the return oil from the chamber G is drain.

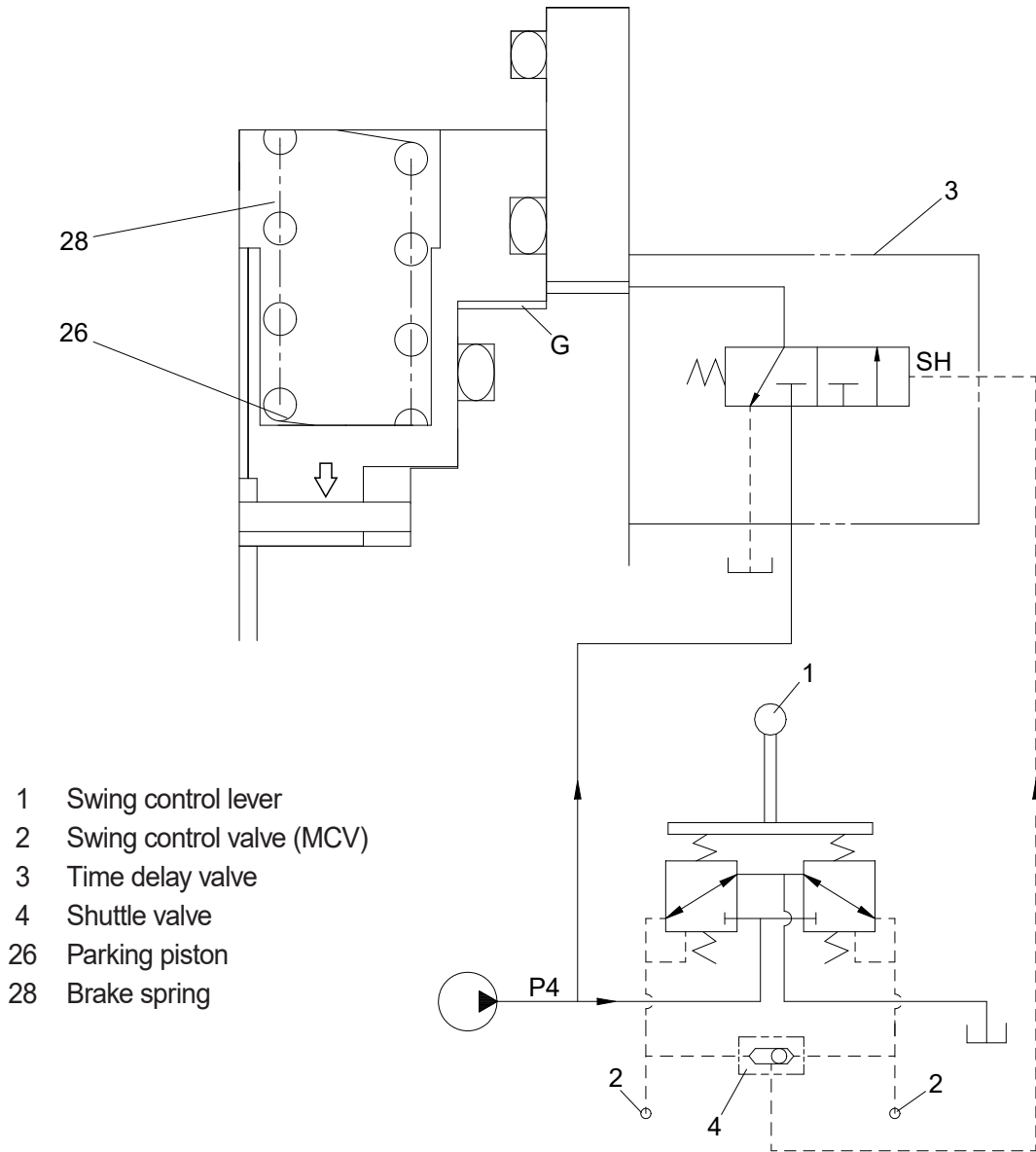

- 1 Swing control lever
- 2 Swing control valve (MCV)
- 3 Time delay valve
- 4 Shuttle valve
- 26 Parking piston
- 28 Brake spring

HX60A2SF40

GROUP 4 TRAVEL DEVICE

1. STRUCTURE

1) TRAVEL MOTOR (1/4)

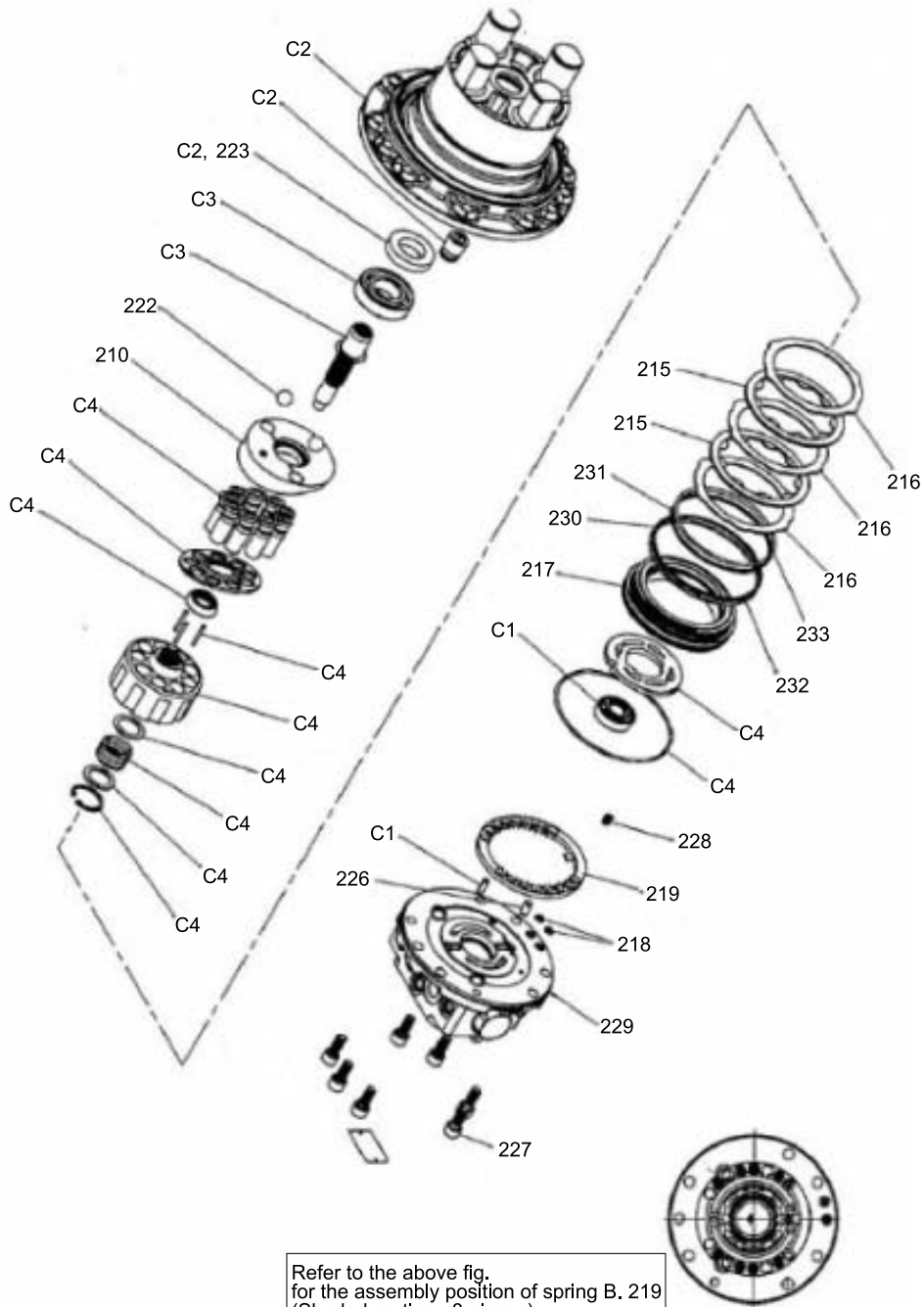

- 210 Swash plate
- 215 Disk
- 216 Steel plate
- 217 Brake piston
- 218 Retainer
- 219 Spring
- 222 Ball
- 223 Oil seal

- 226 Pin
- 227 Screw
- 228 O-ring
- 229 O-ring
- 230 O-ring
- 231 O-ring
- 232 Back-up ring
- 233 Back-up ring

- C1 Body
- C2 Body
- C3 Shaft
- C4 Cylinder barrel

60S2TM20

TRAVEL MOTOR (2/4)

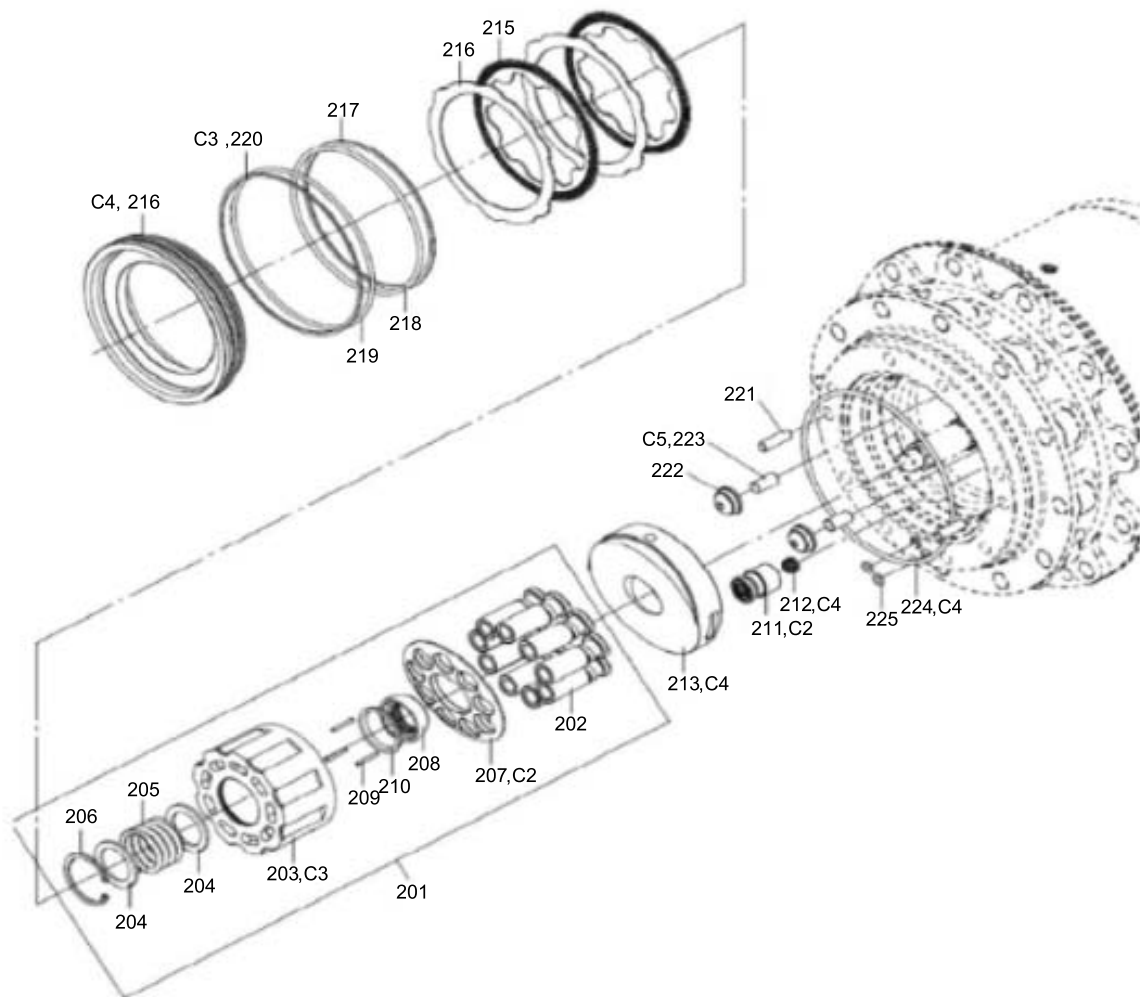

60S2TM21

201	Block & piston kit	211	Piston assy	221	Parallel pin
202	Piston assy	212	Spring	222	Pivot
203	Rotary block	213	Swash plate	223	Pin
204	Washer	214	Piston	224	O-ring
205	Spring	215	Friction plate	225	O-ring
206	Snap ring	216	Separation plate	C2	Body
207	Retainer plate	217	Back up ring	C3	Shaft
208	Bushing	218	O-ring	C4	Cylinder barrel
209	Roller	219	O-ring	C5	Seal kit
210	Collar washer	220	Back up ring		

TRAVEL MOTOR (3/4)

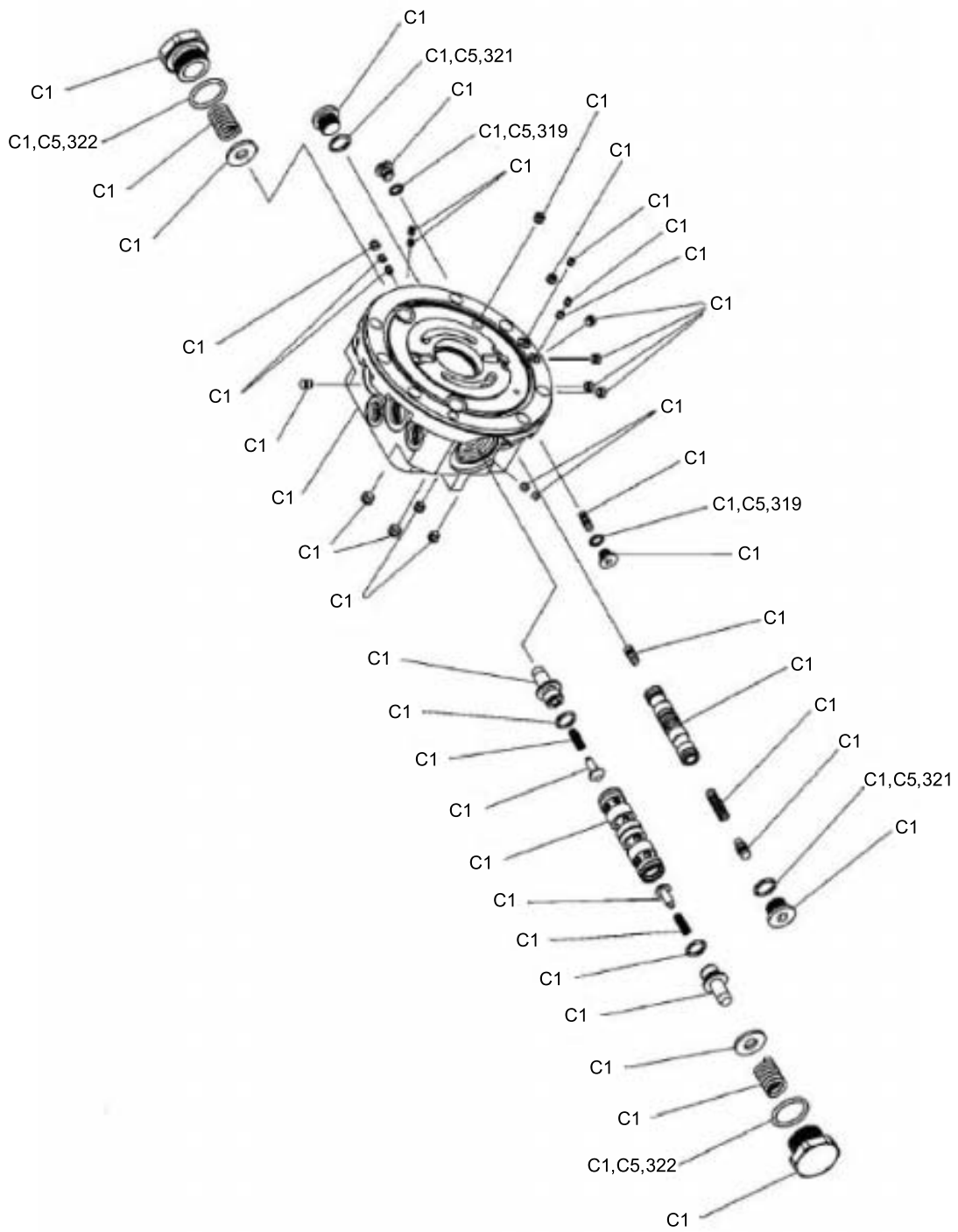

60S2TM22

- 319 O-ring
- 321 O-ring
- 322 O-ring

- C1 Body
- C2 Body
- C3 Shaft

- C4 Cylinder barrel
- C5 Seal kit

TRAVEL MOTOR (4/4)

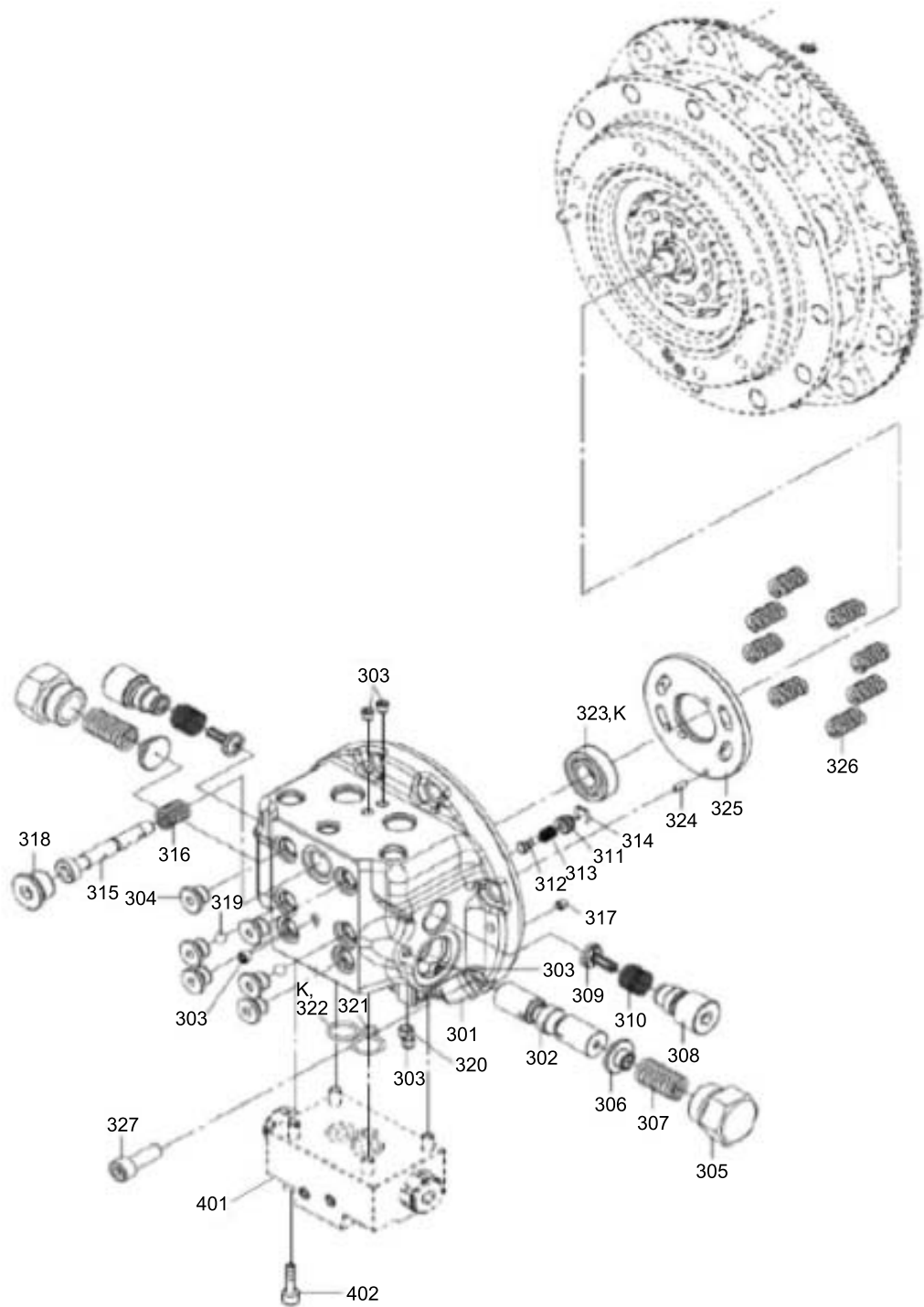

60S2TM23

301	Rear plange	309	Check valve	317	Orifice	325	Timing plate
302	Main spool	310	Spring	318	Plug assy	326	Spring
303	Plug	311	Valve sheet	319	Steel ball	327	Socket bolt
304	Plug assy	312	T type valve	320	Plug	401	Relief valve assy
305	Plug assy	313	Spring	321	O-ring	402	Bolt
306	Spring retainer	314	Ring	322	O-ring		
307	Main spring	315	2-speed spool	323	Bearing		
308	Check plug	316	Spring	324	Pin		

REDUCTION GEAR (1/2)

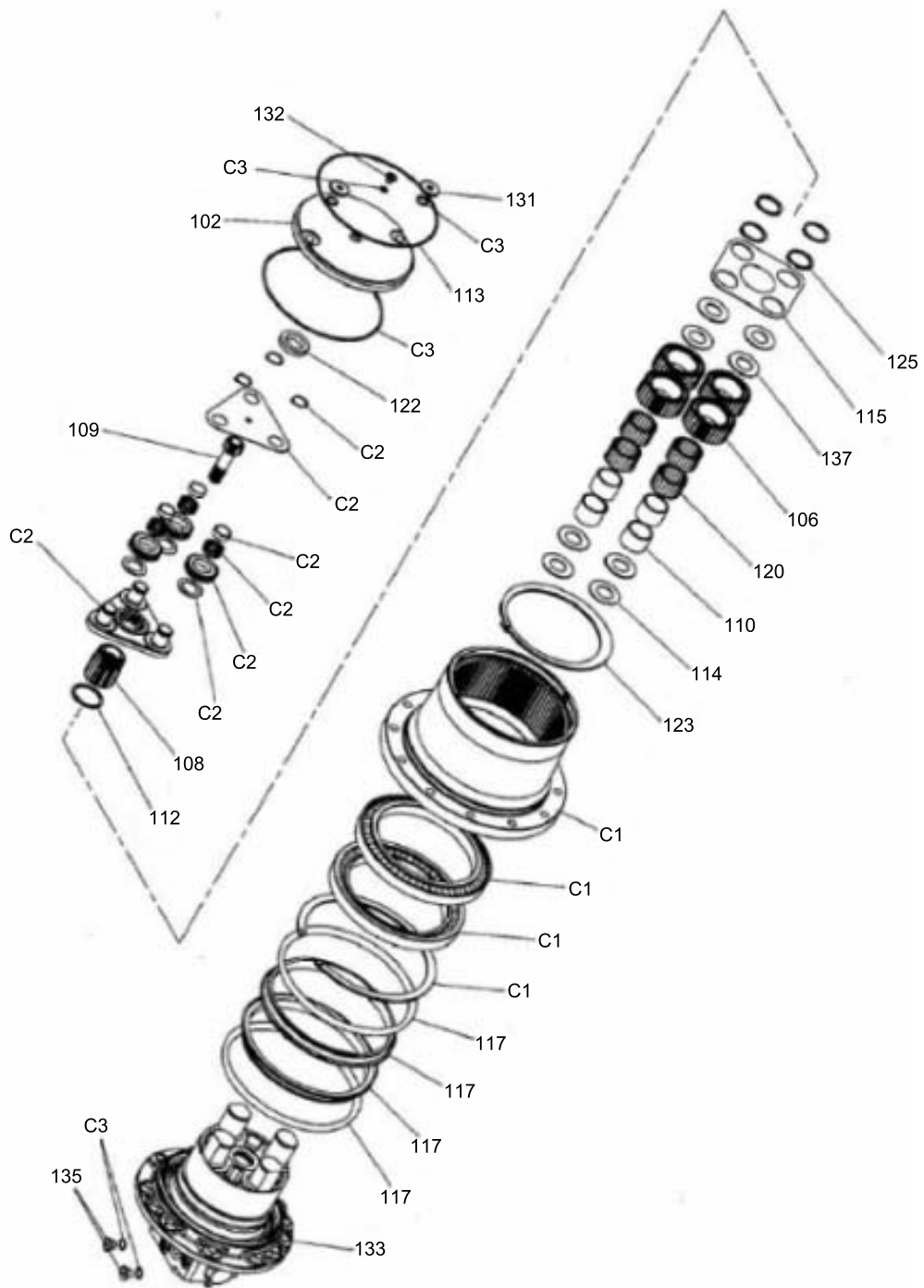

102 Cover
 106 Gear B1
 108 Gear S1
 109 Gear S2
 110 O-ring
 112 Thrust washer
 113 Snap ring
 114 Thrust washer

115 Thrust plate
 117 Floating seat & O-ring
 120 Needle
 122 Ring
 123 Snap ring
 125 Snap ring
 131 Plug
 132 Plug

133 Motor
 135 Plug
 137 Thrust washer
 C1 Body
 C2 Carrier
 C3 Seal kit

60S2TM24

REDUCTION GEAR (2/2)

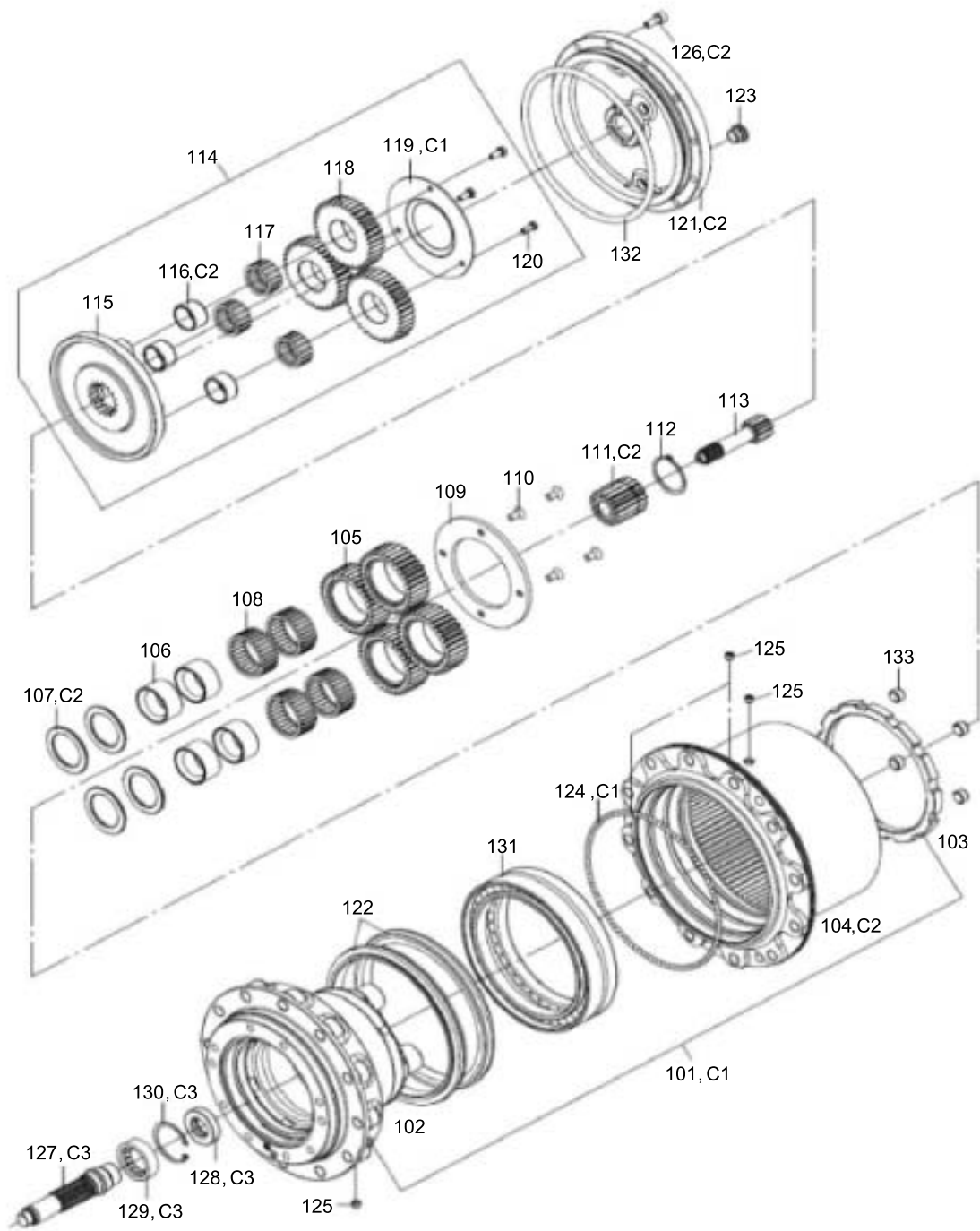

60S2TM25

101	Holder	110	Screw	119	Thrust plate	128	Oil seal
102	Holder	111	Sun gear	120	Bolt	129	Roaller bearing
103	Ring nut	112	Snap ring	121	Cover	130	Snap ring
104	Housing	113	Drive gear	122	Floating seal	131	Ball bearing
105	Gear	114	Holder assy	123	Plug assy	132	O-ring
106	Color	115	Holder	124	Ball	133	Plug
107	Thrust washer	116	Inner race	125	Plug	C1	Body
108	Niddle bearing	117	Niddle bearing	126	Socket bolt	C2	Carrier
109	Plate	118	Gear	127	Drive shaft	C3	Seal kit

2. DRAWING OF OPERATIONAL PRINCIPLE

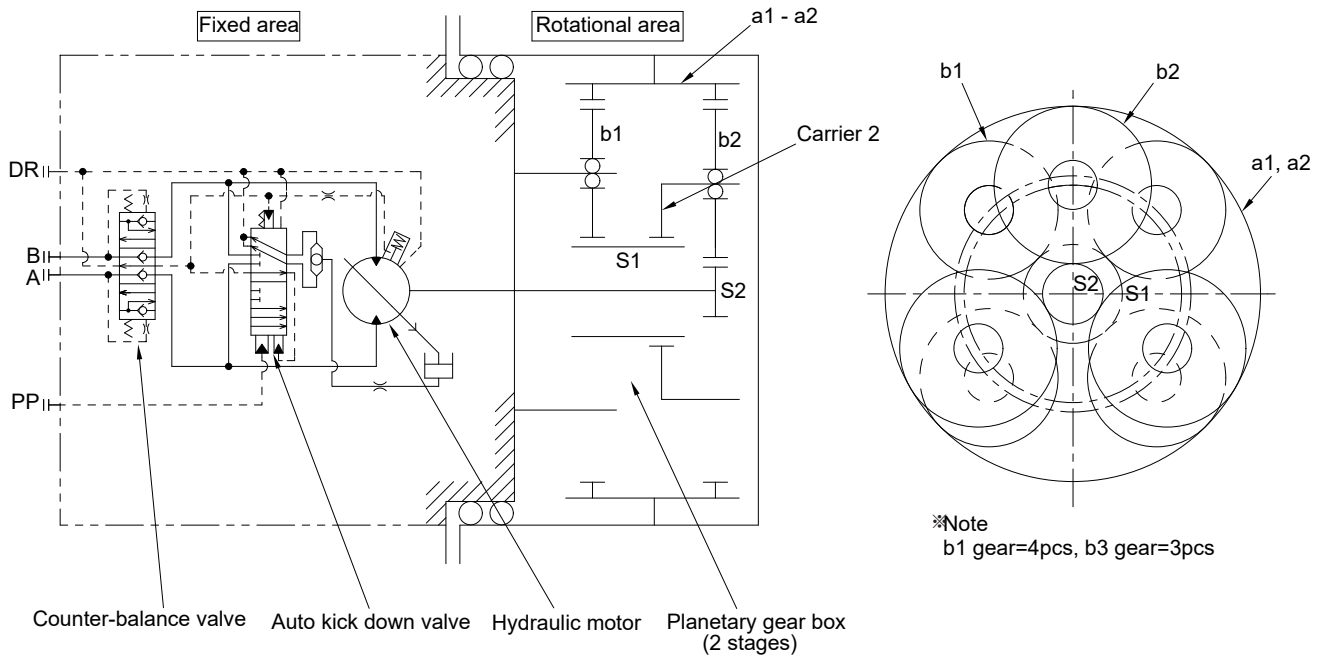

60S2TM03

3. OPERATION

Travel motor consists of a hydraulic motor "Fixed parts" and a planetary gear speed reducer "Rotating parts".

1) REDUCTION GEAR SECTION

(1) Function

The speed reducer of travel motor is a simple planetary gear type with two stages. The high output speed of the hydraulic motor is reduced to low speed with high torque.

(2) Operation

The S2 gear is attached to the hydraulic motor shaft and the S2 output speed is reduced between the gears (s2, b2, a2) as a first stage speed reducer.

The reduced output speed of this first stage is reduced again between the gears (s1, b1, a1) which are connected to the carrier 2 with the spline.

This reduced output speed of the second stage is transmitted to the body case "rotating parts" through the inner gears (a1, a2) and drives the machine.

The gear ratio of 2 stage simple planetary speed reducer is calculated using the following formula.

$$R = \frac{Z_{s1}}{Z_{s1}+Z_{a1}} \times \frac{Z_{s2}}{Z_{s2}+Z_{a2}}$$

※ Z** : Number of teeth

With the travel motor, the body case rotating, so the gear ratio is ;

$$R' = \frac{1}{1-1/R}$$

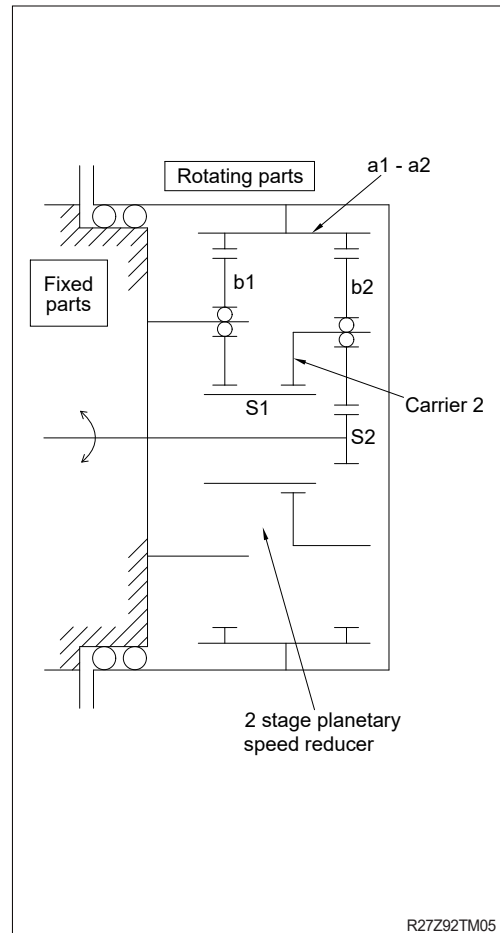

R27Z92TM05

2) HYDRAULIC MOTOR SECTION

(1) Function

This hydraulic motor is an axial piston type, and changes the hydraulic energy supplied from the pump to the rotary motion.

(2) Structure

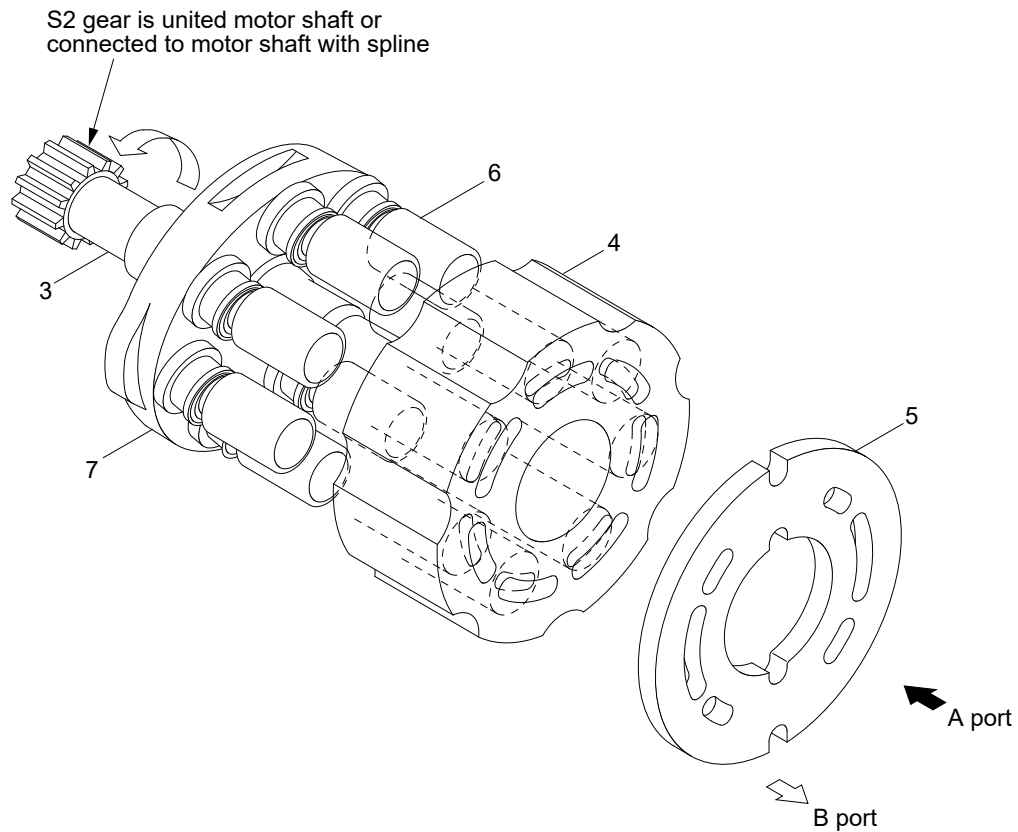

R27Z92TM06

Through a hydraulic valve, the pressurized oil is supplied to the valve plate (5). When the pressurized oil is supplied to the A port, this pressurized oil pushes the piston (6) in the cylinder barrel (4). This pushing force is changed to the rotational power by the swash plate (7) and transmitted to the shaft (3) which is connected to the cylinder barrel (4) with the spline. The return flow from the cylinder port is going out through the B port of the valve plate (5). To reverse rotation, pressurized oil is supplied to the B port and returning oil exits through the A port.

(3) 2 Speed motor operation

The swash plate, which has surface I and II in the opposite side to the shoe sliding surface, is supported by the 2 balls which are fixed to the body 2.

Since the balls are located in the eccentric position, in the low speed range, the surface I is faced to the body 2 by the oil pressure in the piston and the spring force in the cylinder barrel. The swash plate angle is α (Max. capacity).

When the pressurized oil is supplied to the (PP) port, the two-speed spool moves to the high position.

And the pressurized oil of inlet is led to the control chamber through the two-speed spool.

The control piston moves forward until the surface II of the swash plate is in contact with the body 2, and the swash plate angle becomes β .

The capacity of the hydraulic motor is made small.

The pressurized oil of the (PP) port is shut off (or the engine is stopped), the two-speed spool moves to the low position.

And the control chamber is led to the tank port through the two-speed spool and the swash plate position comes to the low speed by the spring force.

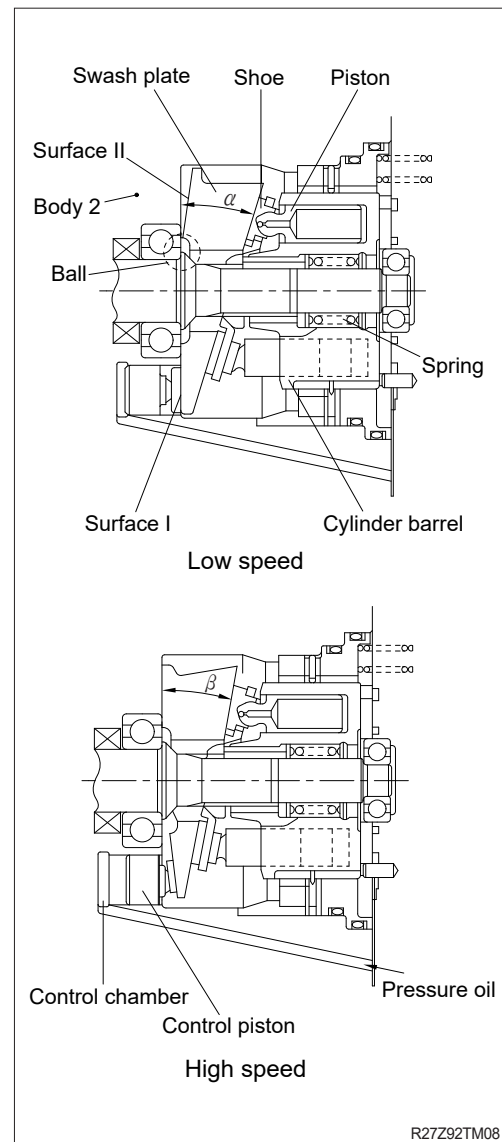

(4) Auto kick down valve

When the pilot switch for Hi speed mode is turned on, the pilot pressure for Hi speed mode comes from PP port to the hydraulic pilot (1), then the force F_1 occurs, The auto kick down valve moves to the right direction because the F_1 is larger than F_4 , which is by spring (4). Then the speed of track motor is changed to the Hi speed mode.

On the other hand, the operating pressure comes from A or B port to the hydraulic pilot (2) and (3), then the force F_2 and F_3 occur. The F_3 larger than F_2 because the area of (3) is wider than the area of (2). Therefore, if the operating pressure increased, the difference between F_2 and F_3 also increases.

When the operating pressure is larger than the setting pressure of Hi speed to Lo speed, the right direction resultant of F_1 and F_2 is smaller than the left direction resultant of F_3 and F_4 .

Therefore the auto kick down valve moves to the left direction, then the speed of track motor is changed to the Lo speed mode. When the operating pressure is smaller than the larger than the left direction resultant of F_3 and F_4 .

Therefore the auto kick down valve moves to the right direction, then the speed of track motor is changed to the Hi speed mode.

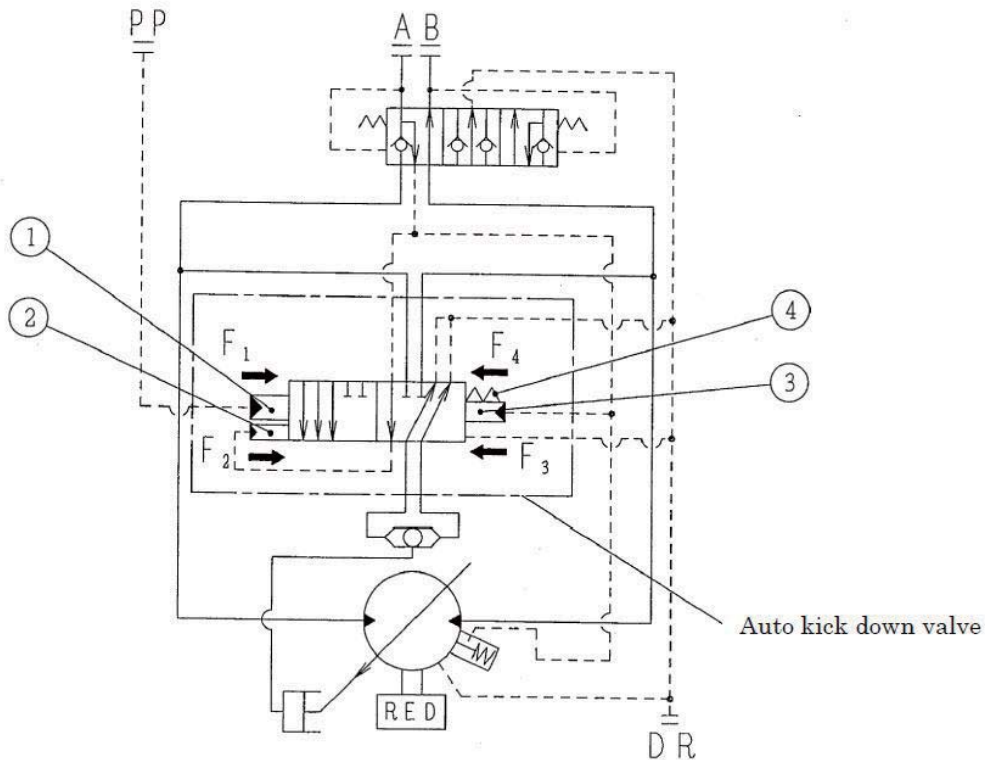

60S2TM09

3) HYDRAULIC VALVE SECTION

(1) Counter-balance valve

When the pressurized oil is supplied from the A port, the pressurized oil opens the check valve (3) and flows into the hydraulic motor inlet A' port. At the same time, the pressurized oil goes through the orifice C into the chamber D, pushes the spring (4) and moves the spool (2) to right. Then the returned oil from the hydraulic motor flows into the B port, goes through area E and drives the hydraulic motor. When the pressurized oil is supplied from the B port, the hydraulic motor rotates in reverse.

Even the pressurized oil of the A port is shut off, the hydraulic motor tries to rotate by inertia force. When the pressurized oil from the A port is shut off, the spool (2) tries to return to left by the spring (4) force. At this time, the oil in the chamber D tries to go out to the A port through the orifice C, but due to the throttle effect of orifice C, the spool (2) speed is reduced. With the orifice and notches on the spool, the returned oil is controlled gradually and the hydraulic motor stops smoothly.

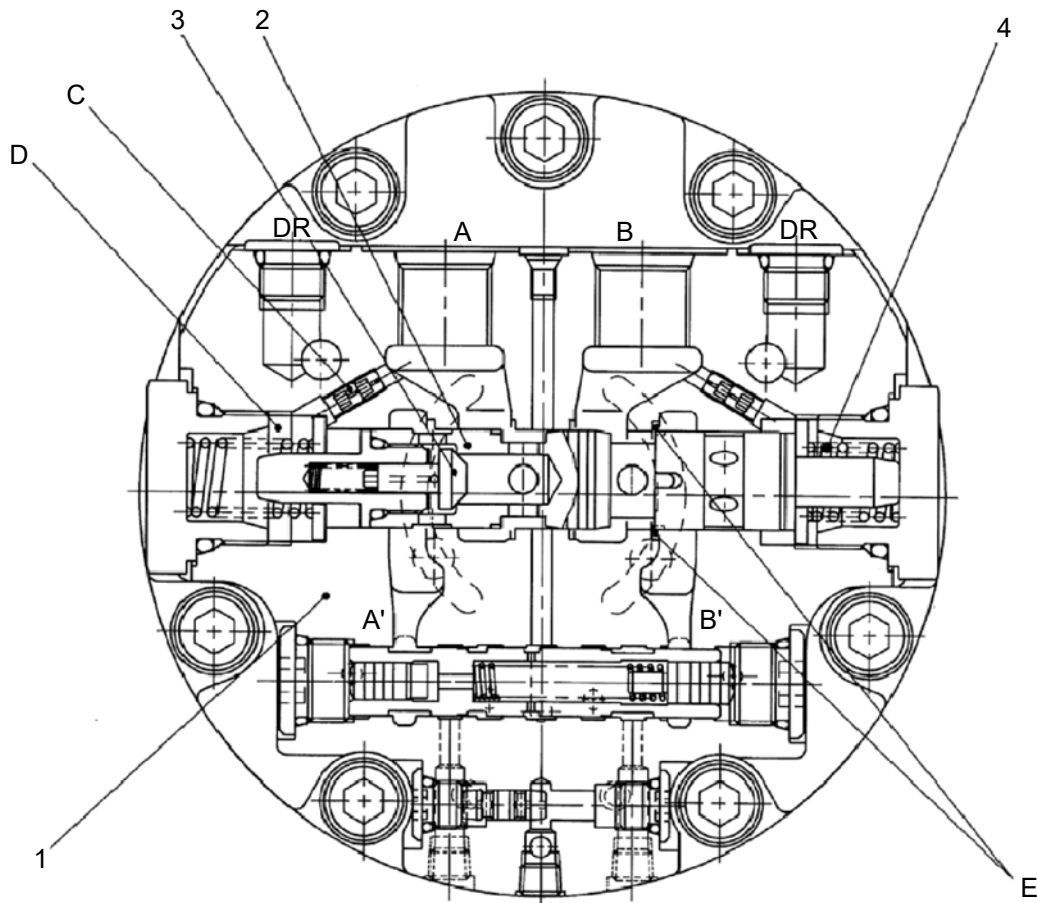

R25Z9AK2TM19

4) PARKING BRAKE SECTION

(1) Structure

The parking brake fixes the output shaft of hydraulic motor mechanically while the travel motor is stopped. And it is applied automatically in the following fashion.

When A and B ports are not pressurized, the brake piston (1) is pressed in the direction (shown as arrow) by the spring (2). Then the disk plate (4) which is fixed to the cylinder barrel (3) is held between the steel plate (6) which are fixed to the body 2 (5) and the body 2 (5). As a result, with the friction of these plates, the cylinder barrel (3) and the hydraulic motor are unable to rotate.

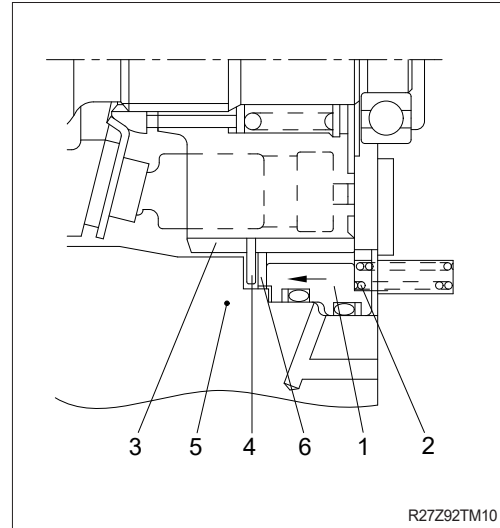

When A or B ports are pressurized, the oil is lead to chamber (7). Then the brake piston (1) is moved to the direction (shown as arrow) against the force of spring (2). As a result, the disk plate (4) is released from the steel plate (6) and the body 2 (5), and the cylinder barrel (3) can be rotated.

