

## SECTION 3 HYDRAULIC AND ELECTRICAL SYSTEM

Group 1 Hydraulic Circuit .....	3-1
Group 2 Monitoring system.....	3-2
Group 3 Electrical Circuit .....	3-22

# SECTION 3 HYDRAULIC AND ELECTRICAL SYSTEM

## GROUP 1 HYDRAULIC CIRCUIT

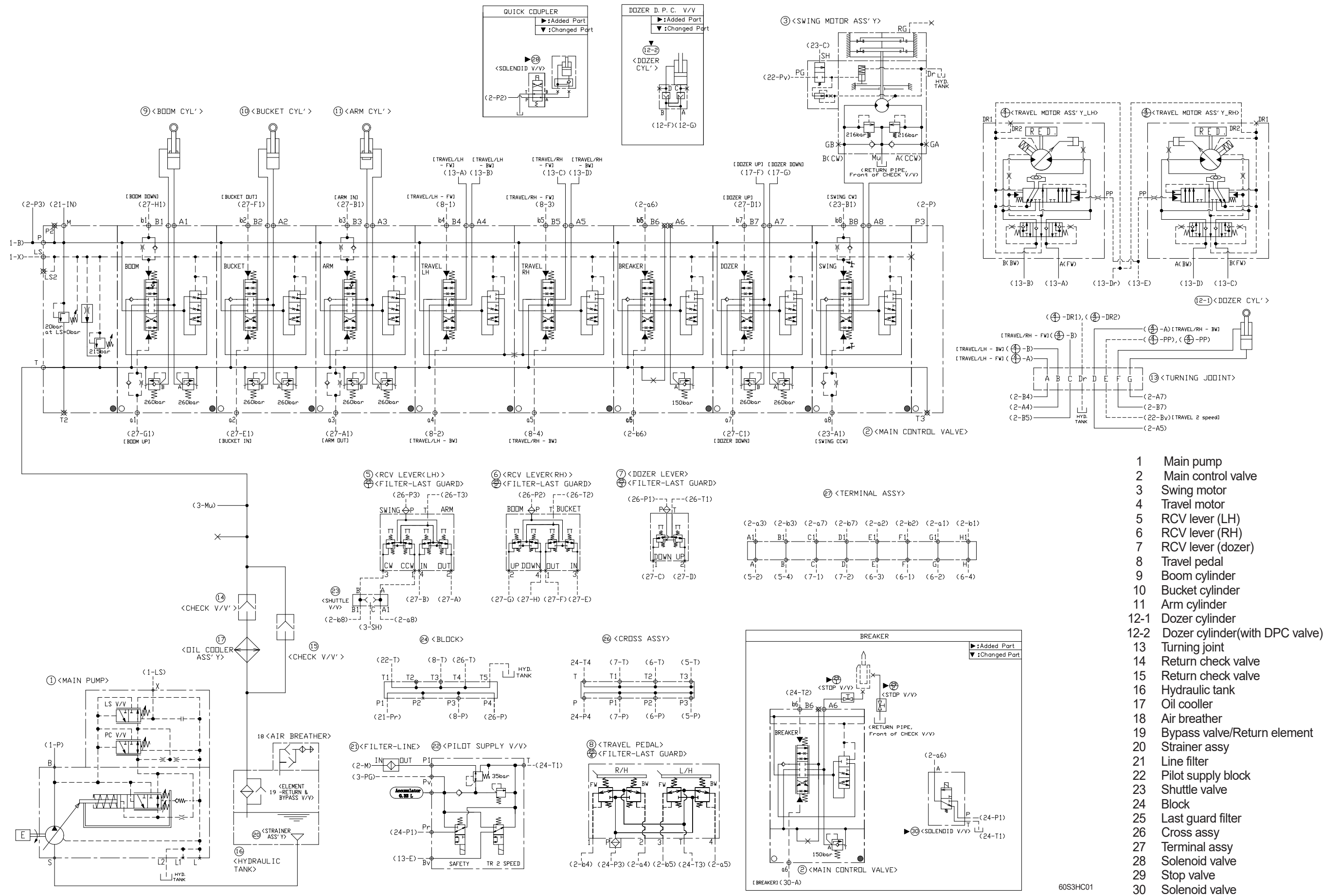

## GROUP 2 MONITORING SYSTEM

### 1. Overview

The cluster consists of the LCD and switches, as shown below. The LCD is to warn the operator in case of abnormal machine operation or conditions for the appropriate operation and inspection. It is also to set and display modes, monitoring and functions.

※ If a device malfunctions, the indicator will be ON and an alarm will be sent. Turn off the buzzer to cancel the alarm. If the indicator is still ON after the buzzer is turned off, take appropriate measures.

### 2. Cluster

#### 1) Structure



## 2) Gauge

### (1) Operation screen

Default (A type)



Option (B type)

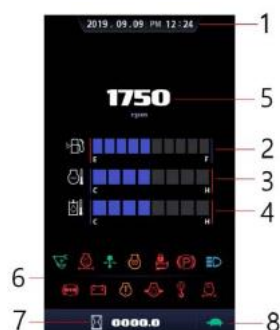

1. Clock
2. Fuel level gauge
3. Engine coolant temperature gauge
4. Hydraulic oil temperature gauge
5. Engine rpm
6. Warning lamp/indicator
7. Working hour gauge
8. Travel speed indicator

### (2) Fuel level gauge

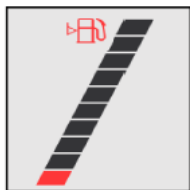

- ① This gauge indicates the amount of fuel in the fuel tank.
  - ② Fill the fuel when the pointer is within the stage 1 or the red lamp is ON.
- ※ If this gauge indicates the red range or the warning lamp is ON, check the electrical device for poor contact and sensor for malfunction.

(3) Hydraulic oil temperature gauge

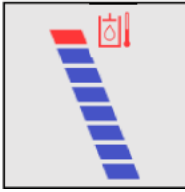

- ① This gauge indicates the temperature of hydraulic oil at 8 stages.
  - Stage 0: 44 °C and below
  - Stages 1-7: 45 °C to 104 °C
  - Stage 8: 105 °C and above
- ② The pointer normally indicates the stages 2-6 during driving.
- ③ The machine runs at the stages 2-6 during low-speed idling after startup.
- ④ Reduce the load when the pointer indicates the stages 7-8. If the pointer still indicates the stages 7-8 after load reduction, stop the machine and check it.

(4) Engine coolant temperature gauge

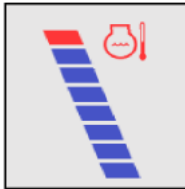

- ① This gauge indicates the temperature of hydraulic oil at 8 stages.
  - Stage 0: 44 °C and below
  - Stages 1-7: 45 °C to 114 °C
  - Stage 8: 115 °C and above
- ② The engine must not be shut down if the red warning lamp is ON. Instead, the engine should be shut down after cooling at an intermediate speed.
  - ※ If the engine is shut down without adequate cooling its temperature will rise rapidly, which may cause damage to internal parts.

(5) Current time

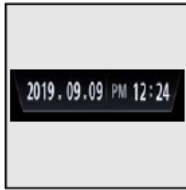

① Indicate the current time.

(6) Working hour gauge



① Indicate the total working hours of the machine.

(7) Engine rpm



① Indicate the engine speed in rpm.

### 3) Warning lamps

#### (1) Fuel level warning lamp

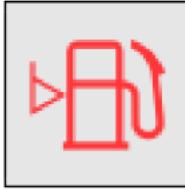

- ① Indicate the amount of fuel in the fuel tank.
- ② Fill fuel immediately if this lamp flickers.

#### (2) Hydraulic oil temperature warning lamp



- ① The lamp is ON and the buzzer sounds when the hydraulic oil temperature is over the reference temperature (105 °C).
- ② When this lamp is ON, check the oil cooling system.
- ③ Check the oil cooler and radiator.

#### (3) Cooling water temperature warning lamp



- ④ The lamp is ON and the buzzer sounds when the cooling water temperature is over the reference temperature (115 °C).
- ① Check the cooling water level if this warning lamp is ON.

#### (4) Engine oil pressure warning lamp



- ① The lamp is ON and the buzzer sounds due to low oil pressure before engine startup. The alarm will be canceled after startup.
- ② If the engine warning lamp is ON, reduce the engine speed or immediately shut down the engine, and check the engine oil level.

(5) Air cleaner warning lamp



- ① This lamp is ON and the buzzer sounds when the filter of the air cleaner is clogged.
- ② If this lamp is ON, check the filter and clean or replace it.

(6) Battery charging warning lamp

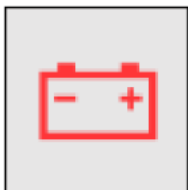

- ① Check whether the charging indicator is ON before starting the engine. If the warning lamp is ON and the buzzer sounds, ignition must not be performed.
- ② If the starting switch is made ON, the warning lamp will be ON and the buzzer will sound. After the engine is started, the warning lamp will be OFF. Check the battery charging line if the warning lamp is ON during engine operation.

(7) Engine check



- ① If the communication between the MCU and engine ECM is abnormal and the engine ECM sends a fault code to the cluster.
- ② Check the communication line. If communication is in good conditions, check the fault code on the cluster.



#### 4) Pilot lamps

##### (1) Engine preheat pilot lamp



- ① When preheating is enabled automatically or manually, this lamp will be ON.
- ② Start the engine after this lamp is OFF.

##### (2) Travel speed pilot lamp (high speed)



- ① If this lamp is ON, the machine is running at a high speed.

##### (3) Travel speed pilot lamp (low speed)

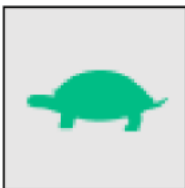

- ① If this lamp is ON, the machine is running at a low speed.

## 5) Switches

### (1) Travel speed switch



- ① Press the travel speed switch on the right side once to enable the high speed mode and again to enable the low speed mode.

### (2) Buzzer stop switch



- ① When the starting switch is turned on, the alarm buzzer sound for 6 seconds under normal circumstances.
- ② If the machine fails, the red pilot lamp will be ON, and the buzzer will sound. In this case, press this switch to shut down the buzzer. Then the LED on this switch will be ON. Wait until it is OFF.

### (3) ESC switch



- ① Go back to the previous menu.

### (4) Select switch





- ① Go back to the menu or use it after changing the input value.

### 3. Functions

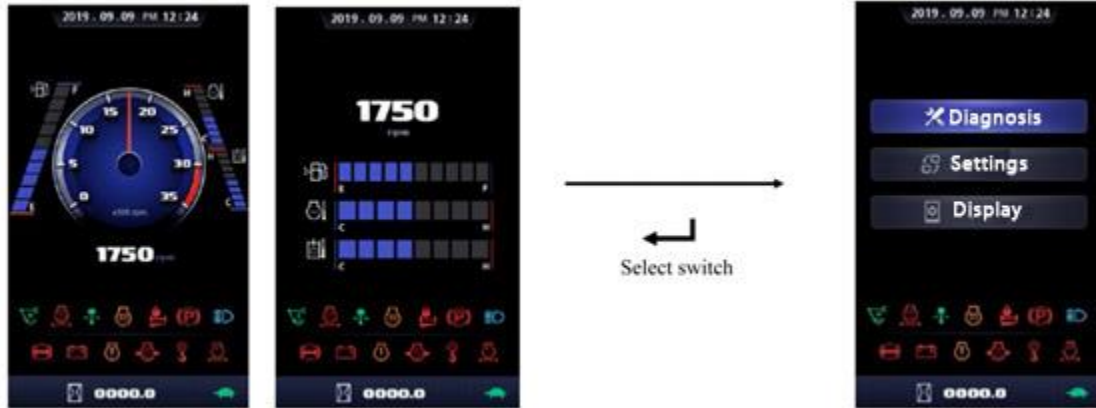
#### 1) Menu



#### 2) Structure

No	Main menu	Sub-menu	Description
1	 Fault diagnosis	Active fault diagnosis Logged fault diagnosis	Confirmation and deletion of faults recorded in MCU and engine ECM
2	 Change setting	Time setting Start limit	Time setting Start limit and password change
3	 Screen setting	Operation screen Screen brightness Language Version Info	Working mode selection Brightness setting Language setting Device information confirmation

### 3) Fault diagnosis

#### (1) Active fault diagnosis

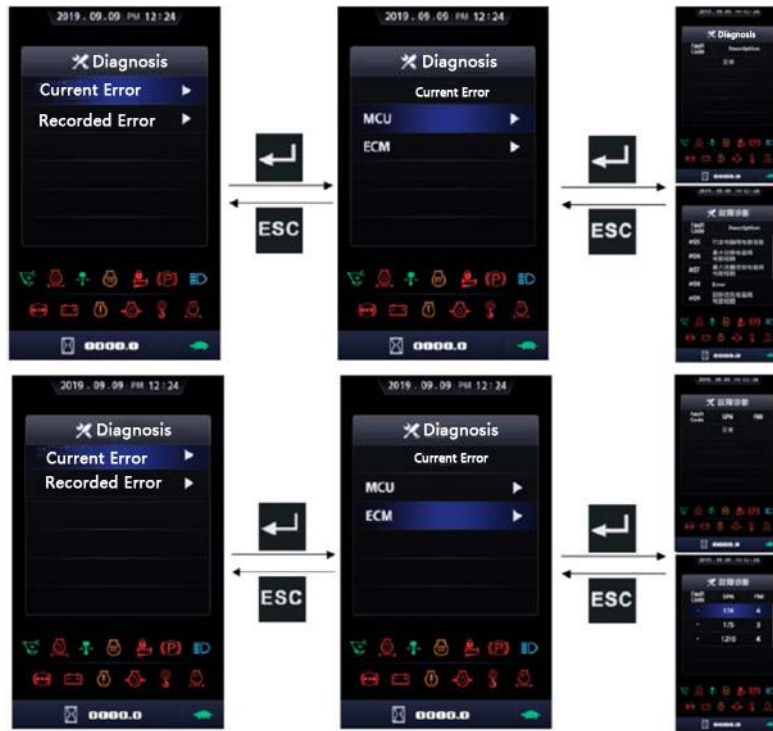

① The active fault of the MCU or engine ECM can be checked.

#### (2) Logged fault diagnosis

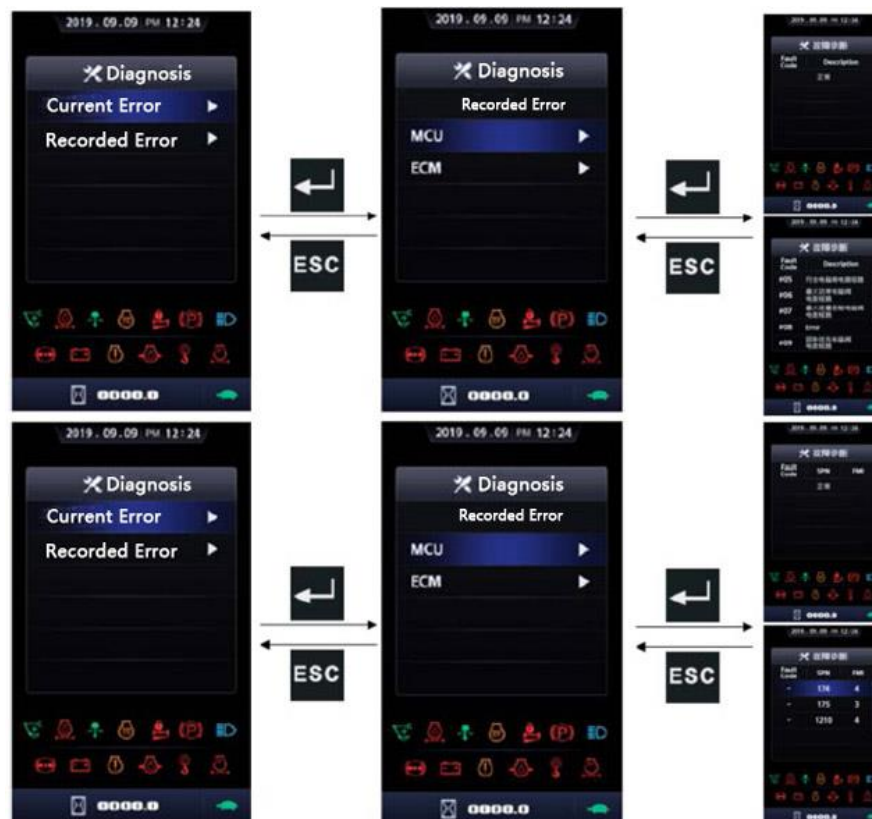

① The logged fault of the MCU or engine ECM can be checked.

#### 4) Change setting

##### (1) Time setting



① The year, month, day, hour and minute can be set.

##### (2) Start limit

###### a. Start limit setting



① This is designed against stealing and for the device that is not permitted to work.

- ② If the starting switch is ON during the start limit setting, it is required to enter the password.
- This function is disabled when not used.
- The operator needs to enter the password each time before startup.
- To set the start delay, it is required to enter the password after the first startup, but not required to restart the machine during the delay period. The maximum delay period is 7 days.

b. Change password



- ① The password consists of 4 digits. Press “” after entering the password.
- ② The initial password is “0000”.

5) Screen setting

(1) Operation screen



- ① The type of the operation screen can be set: analog/digital.

(2) Screen brightness

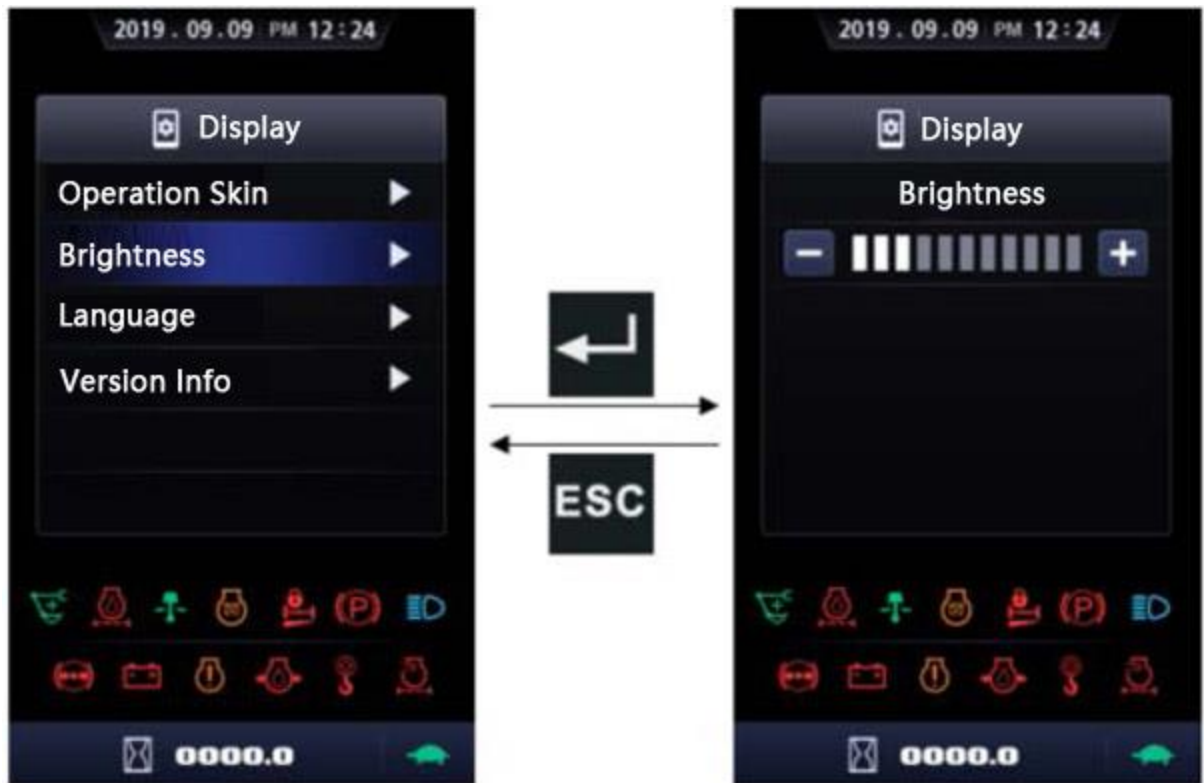

① The screen brightness can be set.

(3) Language



① The desired language can be selected. The screen will show the selected language.

(4) Version information





① The F/W, Image, GPS version and model of the device can be confirmed.



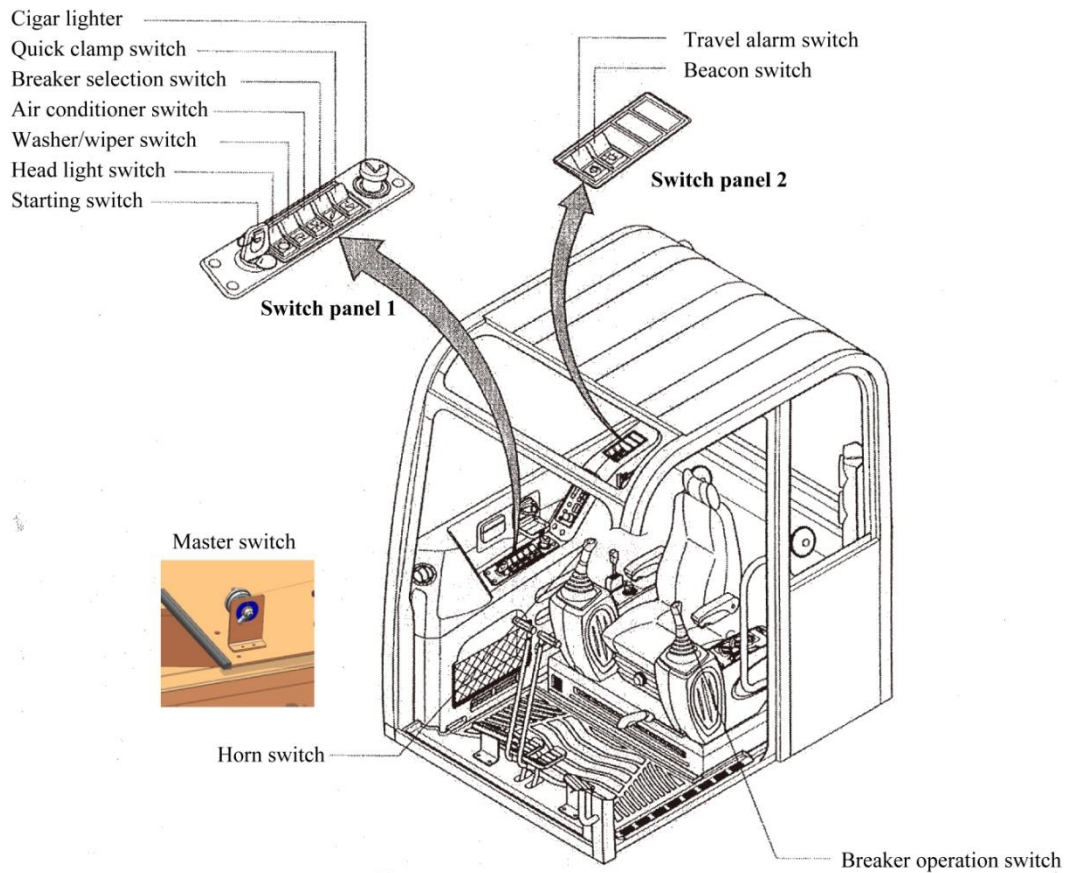

## 2. Switches

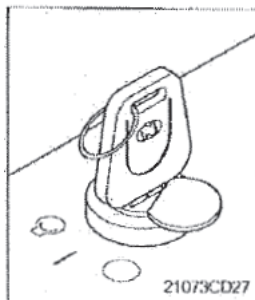

### 1) Starting switch



- (1) There are three positions: OFF, ON and START.
  - (2)  (OFF): None of electrical systems activate.
  - (3)  (ON): All the systems operate.
  - (4)  (START): Use when starting the engine. Release the key immediately after starting.
- ※ The key must be in the ON position with engine running to maintain electrical and hydraulic functions and prevent serious machine damage.

## 2) Master switch

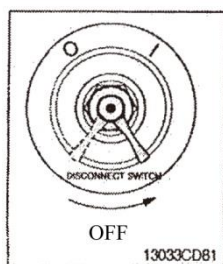

- (1) This switch is used to shut off the entire electrical system.
  - (2) I: The battery remains connected to the electrical system.  
O: The battery is disconnected to the electrical system.
- ※ Never turn the master switch to O (OFF) with the engine running. It could result in engine and electrical system damage.

## 3) Main light switch

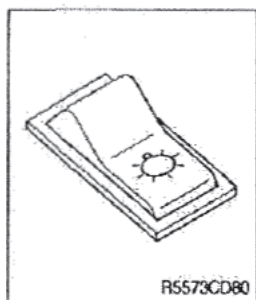

- (1) This switch has two modes for operation of the head light and work light.
- Mode 1: The beacons of the head light and instrument are ON.
  - Mode 2: The work light and the beacon below it are ON.

## 4) Wiper and washer switch



- (1) This switch has two modes for operation of the wiper and washer.
- Mode 1: the wiper can be operated.
  - Mode 2: If this switch is turned to the mode 2, washing fluid will be sprayed and the wiper will work. If this switch is released, the mode 1 will be enabled.

## 5) Travel alarm switch (optional)



- (1) This switch is used to alarm surroundings when the machine travels to forward and backward.
- (2) On pressing this switch, the alarm operates only when the machine is traveling.

## 6) Air conditioner switch



- (1) This switch is used to operate the air conditioner.
- (2) See the air conditioner and heater instructions for details.

### 7) Quick clamp switch (optional)

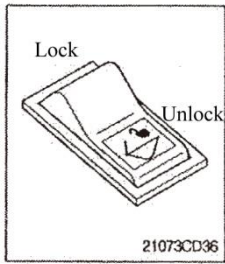

(1) This switch is used to engage or disengage the hook on the quick clamp.

(2) See the “Quick Clamp” for details.

※ The quick clamp must be operated with the quick clamp switch in the lock position and the safety pin assembled.

### 8) Breaker selection switch (optional)



(1) This switch is used to control the breaker.

(2) On pressing this switch, the breaker will operate.

### 9) Swing beacon switch (optional)



(1) This switch is used to turn on the swing beacon in the cab.

(2) On pressing this switch, the beacon below will be ON.

### 10) Horn switch

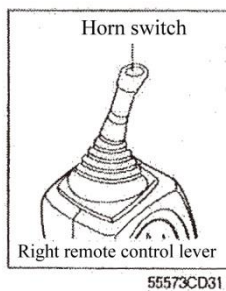

(1) This switch is at the top of left side control lever. On pressing, the horn sounds.

### 11) Breaker operation switch

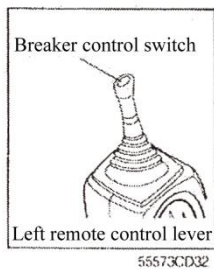

(1) On pressing this switch, the breaker operates only when the breaker selection switch on the switch panel is selected.

## 4. Levers and Pedals

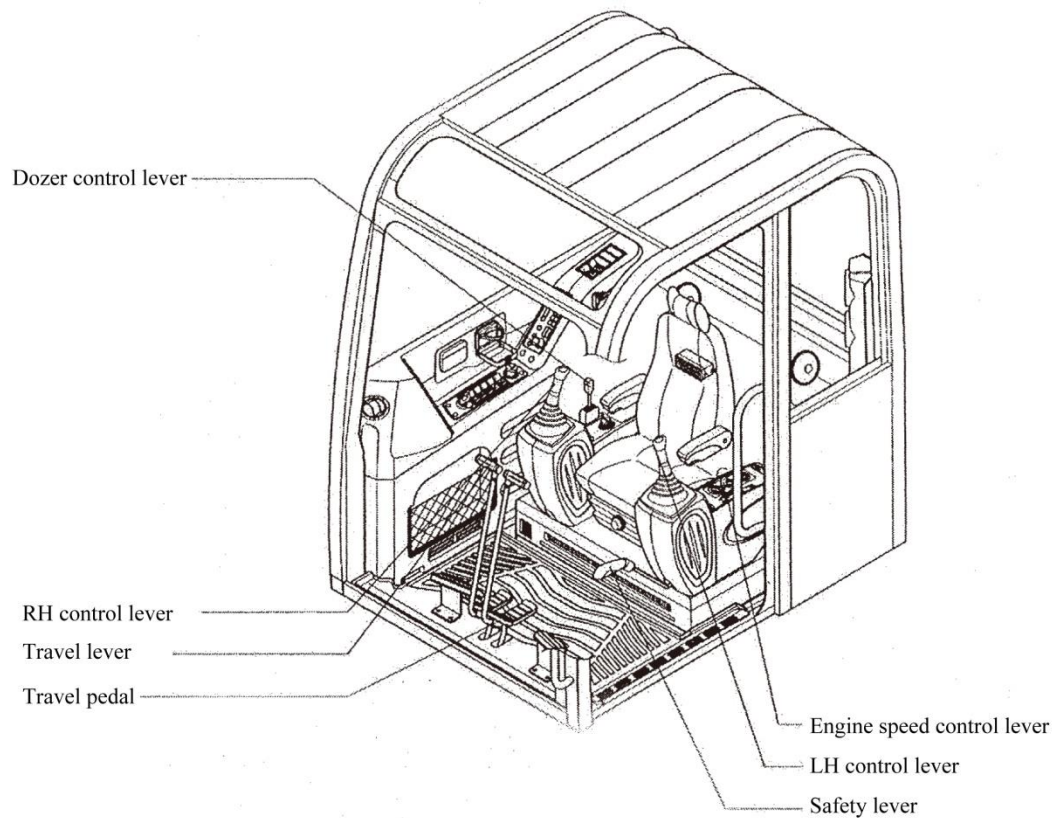

### 1) LH control lever



- (1) This joystick is used to control the swing and arm.
- (2) Refer to the operation of working devices in Chapter 4 for details.

### 2) RH control lever

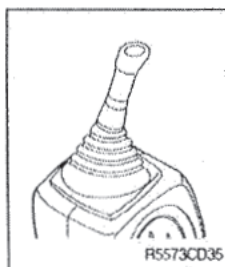

- (1) This joystick is used to control the boom and bucket.
- (2) Refer to the operation of working devices in Chapter 4 for details.

### 3) Safety lever

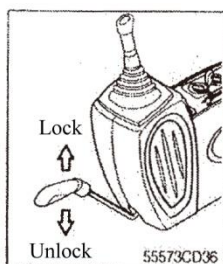

(1) When this lever is in the LOCK position, the console box will be raised, the pilot oil line will be cut off, and the working device and swing will not work.

※ Be sure to raise the lever to the LOCK position when leaving from operator's seat.

(2) By pushing the lever to UNLOCK position, the machine is operational.

※ Do not use the safety lever as a handle when getting on or off the machine.

### 4) Travel lever

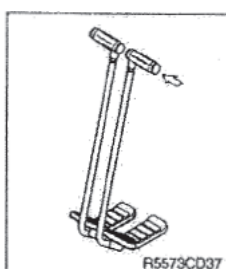

(1) This lever is mounted on the travel pedal and used for traveling by hand. The operation principle is same as that of the travel pedal.

(2) Refer to the "Traveling of Machine" for details.

### 5) Travel pedal

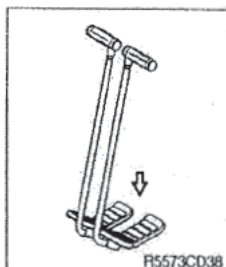

(1) This pedal is used to move the machine forward or backward.

(2) If the left side pedal is pressed, the left track will move. If the right side pedal is pressed, the right track will move.

(3) Refer to the "Traveling of Machine" for details.

### 6) Seat and console box adjust lever

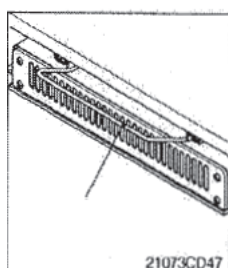

(1) This lever is used to move the seat and console box to fit the contours of the operator's body.

(2) Pull the lever to adjust forward or backward over 90 mm (3.5").

### 7) Engine speed control lever

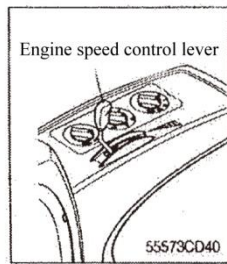

- (1) This control lever is to increase or decrease the engine speed.
- (2) Move this control lever backward to increase the engine speed and forward to decrease the engine speed.
- (3) To stop the engine, move the engine speed control lever forward to the maximum, and turn the key to the OFF position.

### 8) Dozer control lever

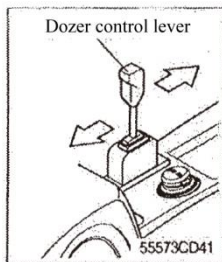

- (1) This lever is used to operate the dozer blade.
- (2) If the lever is pushed forward, the dozer blade will be going down.  
If the lever is pulled back, the dozer blade will be going up.





## 1. POWER CIRCUIT

The negative terminal of battery is grounded to the machine chassis.

When the start switch is in the OFF position, the current flows from the positive battery terminal as shown below.

### 1) OPERATING FLOW

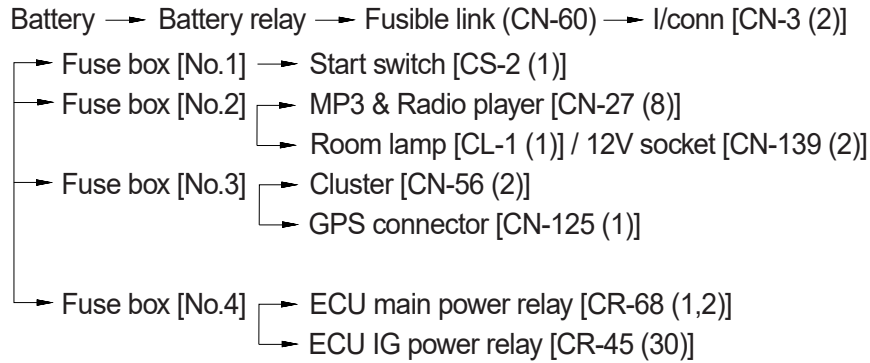

※ I/conn : Intermediate connector

### 2) CHECK POINT

Engine	Start switch	Check point	Voltage
OFF	OFF	① - GND (battery) ② - GND (battery relay) ③ - GND (fusible link)	10~12.5V

※ GND : Ground



# POWER CIRCUIT

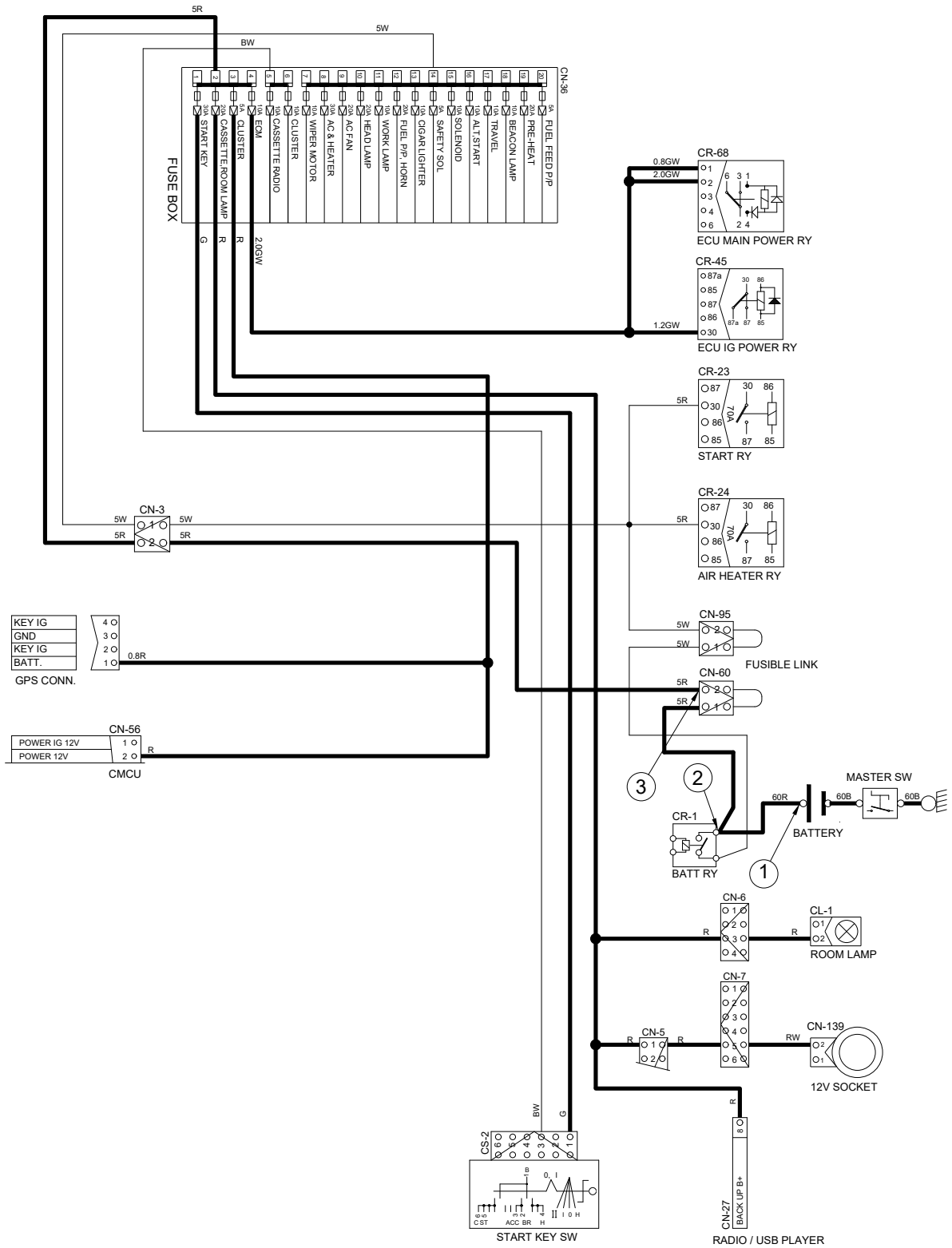

## 2. STARTING CIRCUIT

### 1) OPERATING FLOW

Battery (+) terminal → Battery relay [CR-1] → Fusible link [CN-60]  
 → I/conn [CN-3 (2)] → Fuse box No.1 → Start key [CS-2 (1)]

※ Start switch : ON

→ Start switch ON [CS-2 (2)] → ECU IG power relay [CR-45 (86)]  
 → I/conn [CN-5 (9)] →  
 Battery relay [CR-1]: Battery relay operating (all power is supplied with the electric component)  
 → Start switch ON [CS-2 (3)] → Fuse box (all power is supplied with electric component)

※ Start switch : START

Start switch START [CS-2 (5)] → Anti-restart relay [CR-5 (86) → (87)] → I/conn [CN-4 (11)]  
 → Start relay [CR-23 (C2) → (2)] → Starter motor operating  
 → I/conn [CN-2 (10)] → ECU [CN-93 (8)]

### 2) CHECK POINT

Engine	Start switch	Check point	Voltage
Operating	Start	① - GND (battery) ② - GND (start key) ③ - GND (battery relay M4) ④ - GND (starter B <sup>+</sup> ) ⑤ - GND (starter M) ⑥ - GND (start relay) ⑦ - GND (battery relay M8)	10~12.5V

※ GND : Ground

# STARTING CIRCUIT

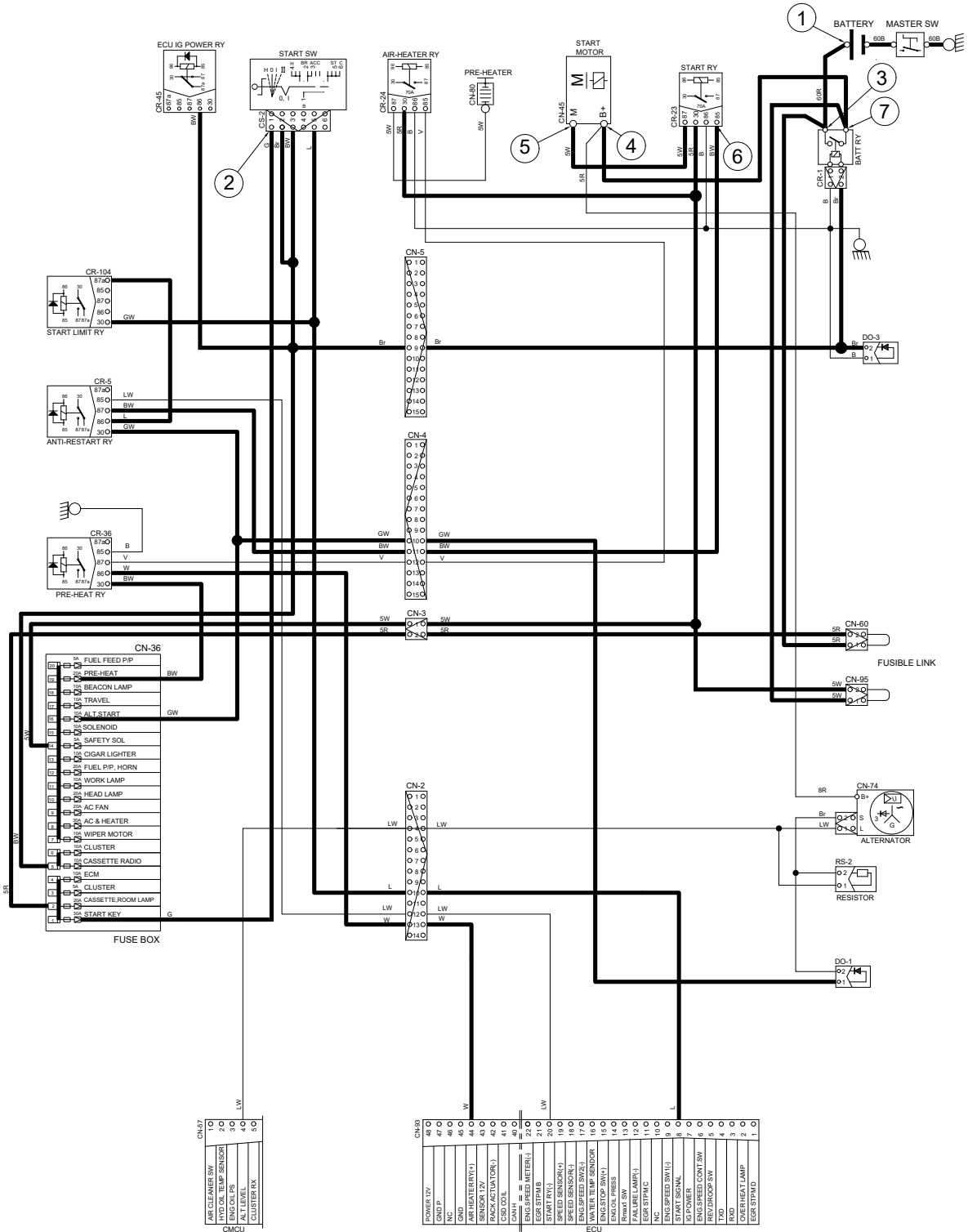

### 3. CHARGING CIRCUIT

When the starter is activated and the engine is started, the operator releases the key switch to the ON position.

Charging current generated by operating alternator flows into the battery through the Battery relay (CR-1).

The current also flows from alternator to each electrical component and controller through the fuse box.

#### 1) OPERATING FLOW

##### (1) Warning flow

Alternator "L" terminal → I/conn [CN-2 (4)] → Cluster [CN-57 (4)] → Cluster warning lamp

##### (2) Charging flow

Alternator "B+" terminal → Battery relay → Battery (+) terminal

#### 2) CHECK POINT

Engine	Start switch	Check point	Voltage
Operating	Start	① – GND (battery voltage) ② – GND (battery relay) ③ – GND (alternator B <sup>+</sup> terminal) ④ – GND (alternator L terminal) ⑤ – GND (cluster)	10~12.5V

※ GND : Ground



## 4. HEAD AND WORK LAMP CIRCUIT

### 1) OPERATING FLOW

Fuse box (No.10) → Head lamp relay [CR-13 (30) → (86)] → Switch [CS-21 (5)]

Fuse box (No.11) → Work lamp relay [CR-3 (30) → (86)] → Switch [CS-21 (2)]

#### (1) Head lamp switch ON

Head lamp switch ON [CS-21 (5)] → Head lamp relay [CR-13 (86) → (87)]

→ I/conn [CN-4 (2)] → Head lamp ON [CL-3 (2)]

→ Cigar lighter [CL-2 (1)]

→ MP3 & Radio player illumination ON [CN-27 (9)]

→ Cluster illumination ON [CN-57 (14)]

#### (2) Work lamp switch ON

Work lamp switch ON [CS-21 (2)] → Work lamp [CR-3 (30) → (87)] → I/conn [CN-4 (8)]

I/conn [CN-12 (2)] → Work lamp ON [CL-5 (2)]

# HEAD AND WORK LAMP CIRCUIT

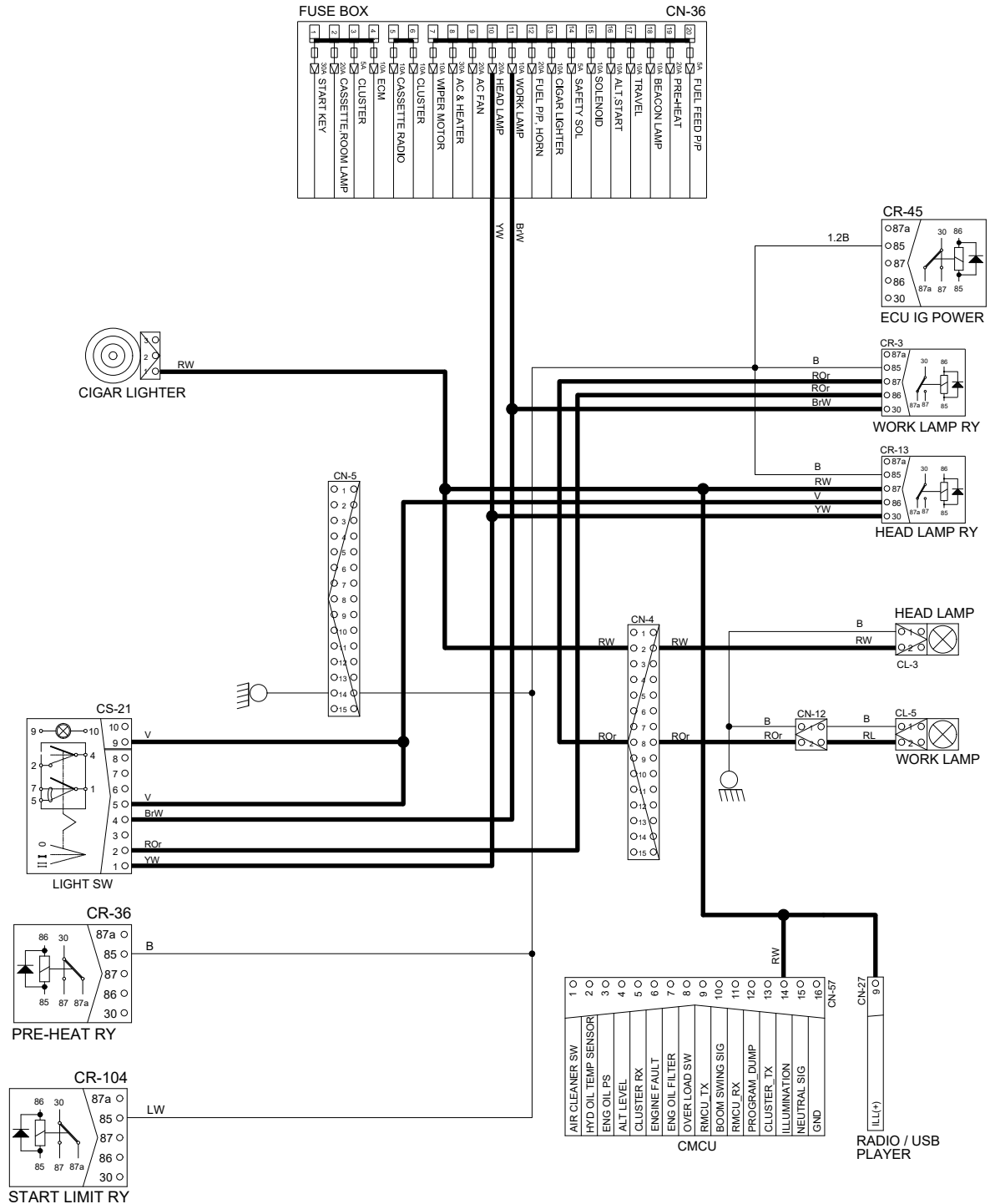

## 5. WIPER AND WASHER CIRCUIT

### 1) OPERATING FLOW

#### (1) Key switch ON

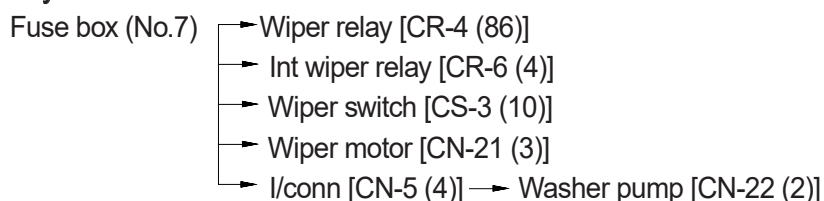

#### (2) Wipe switch ON : 1st step (low speed)

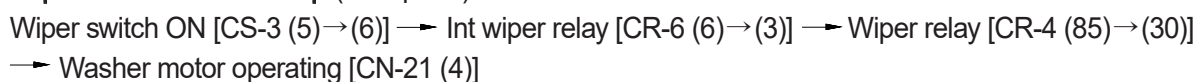

#### (3) Wiper switch ON : 2nd step (washer)

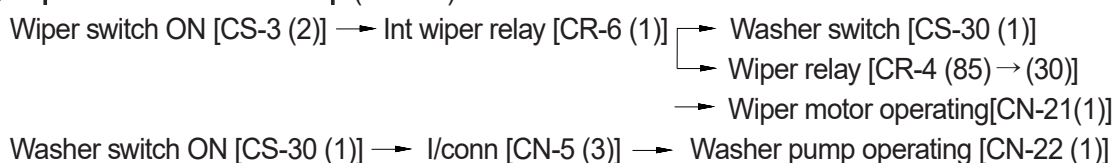

#### (4) Auto parking (when switch OFF)

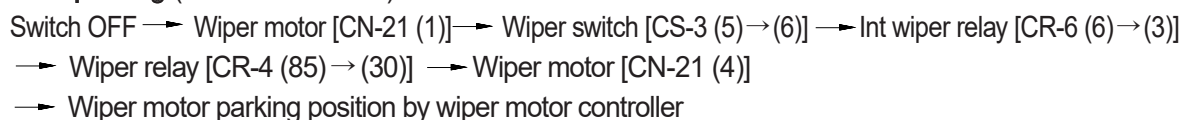

### 2) CHECK POINT

Engine	Start switch	Check point	Voltage
STOP	ON	① - GND (fuse box) ② - GND (switch power input) ③ - GND (switch power output) ④ - GND (wiper motor)	10~12.5V

※ GND : Ground



# WIPER AND WASHER CIRCUIT

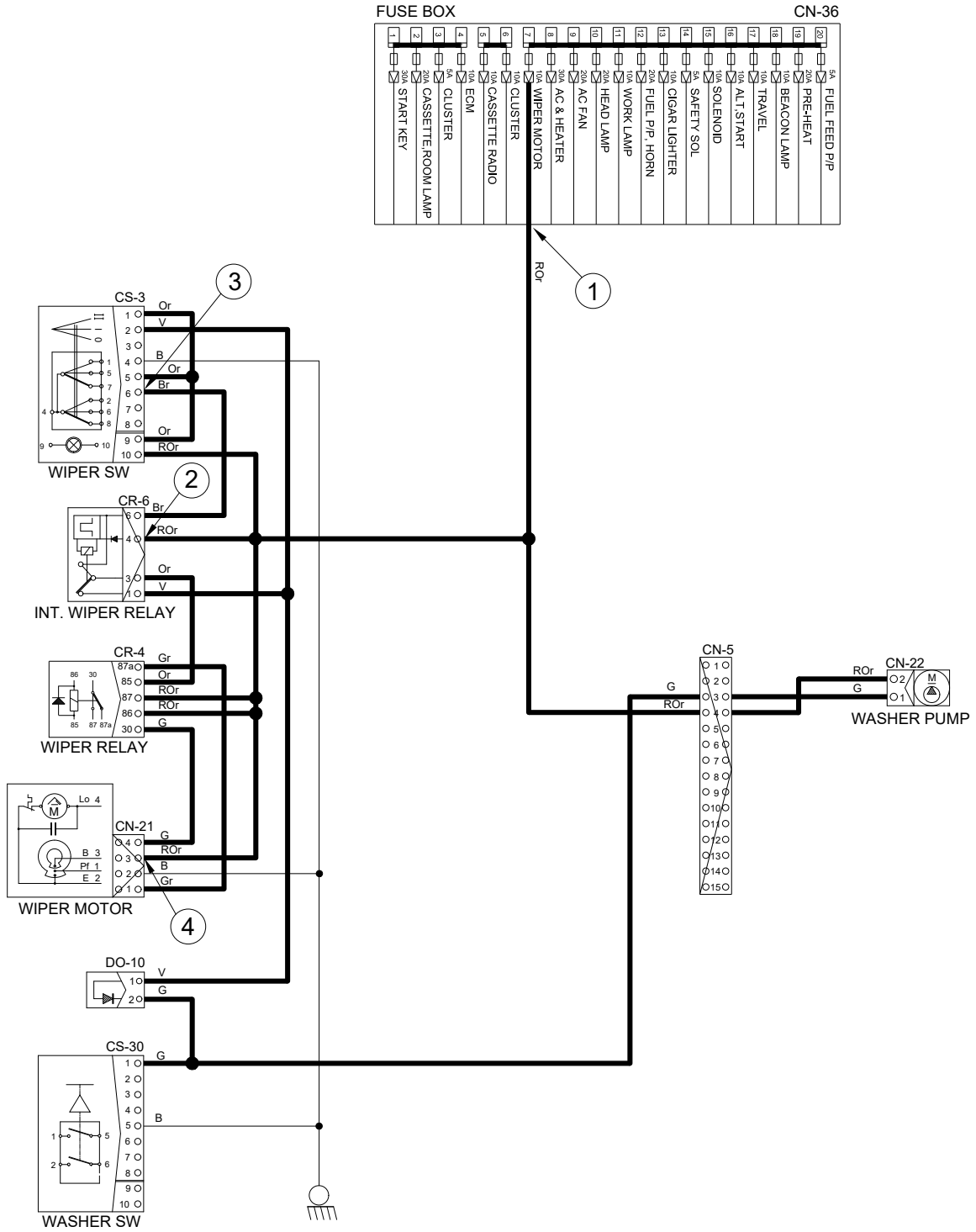

# MONITORING CIRCUIT

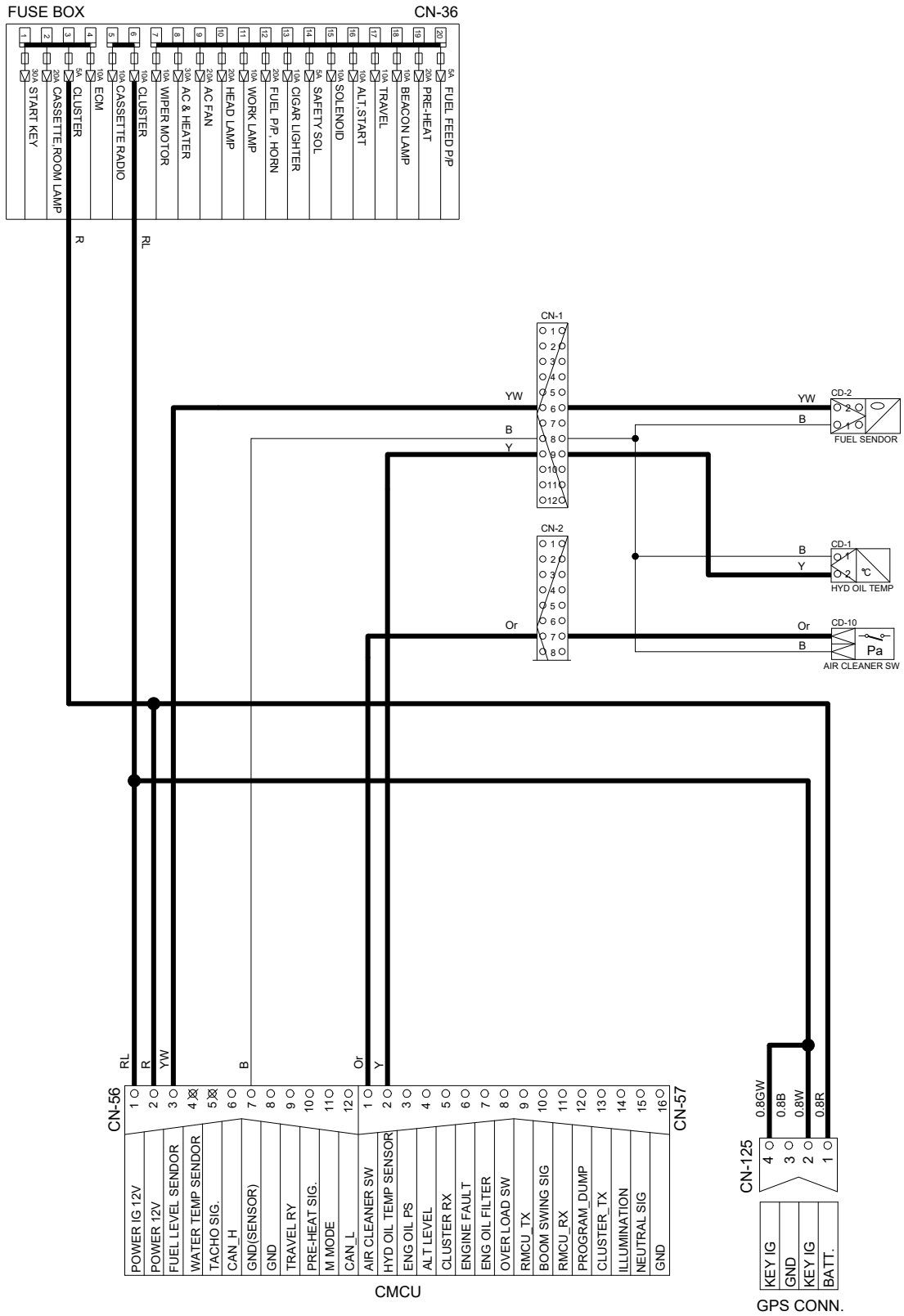

60S4EL10

# ELECTRIC CIRCUIT FOR HYDRAULIC

