

SECTION 1 GENERAL



Group 1 Safety Hints	1-1
Group 2 Specifications	1-10

SECTION 1 GENERAL

GROUP 1 SAFETY

FOLLOW SAFE PROCEDURE

Unsafe work practices are dangerous. Understand service procedure before doing work; Do not attempt shortcuts.

WEAR PROTECTIVE CLOTHING

Wear close fitting clothing and safety equipment appropriate to the job.

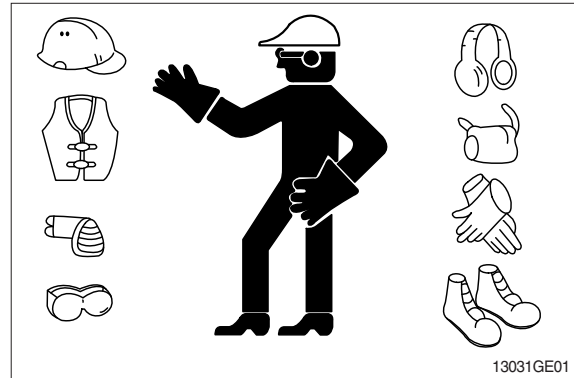

WARN OTHERS OF SERVICE WORK

Unexpected machine movement can cause serious injury.

Before performing any work on the excavator, attach a 「Do Not Operate」 tag on the right side control lever.

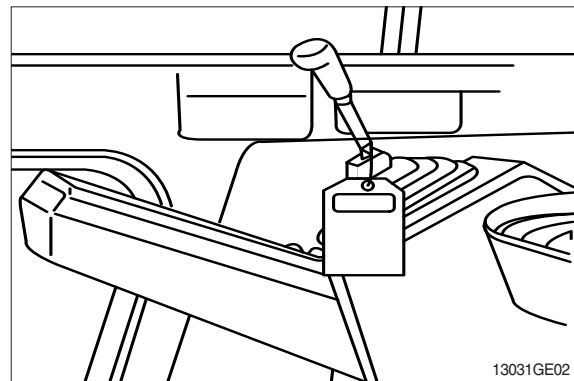

USE HANDHOLDS AND STEPS

Falling is one of the major causes of personal injury.

When you get on and off the machine, always maintain a three point contact with the steps and handrails and face the machine. Do not use any controls as handholds.

Never jump on or off the machine. Never mount or dismount a moving machine.

Be careful of slippery conditions on platforms, steps, and handrails when leaving the machine.

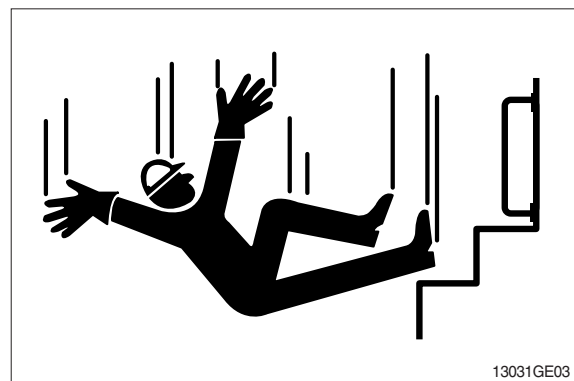

PREPARE FOR EMERGENCIES

Be prepared if a fire starts.

Keep a first aid kit and fire extinguisher handy.

Keep emergency numbers for doctors, ambulance service, hospital, and fire department near your telephone.

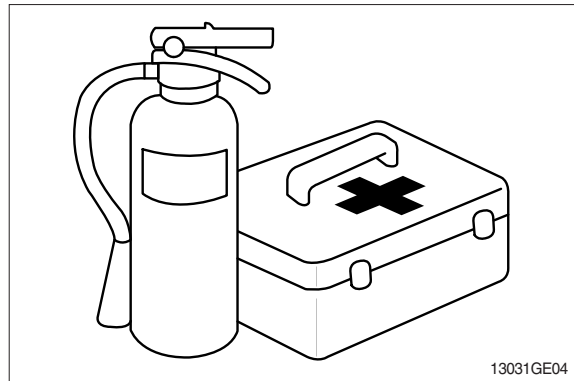

PROTECT AGAINST FLYING DEBRIS

Guard against injury from flying pieces of metal or debris; Wear goggles or safety glasses.

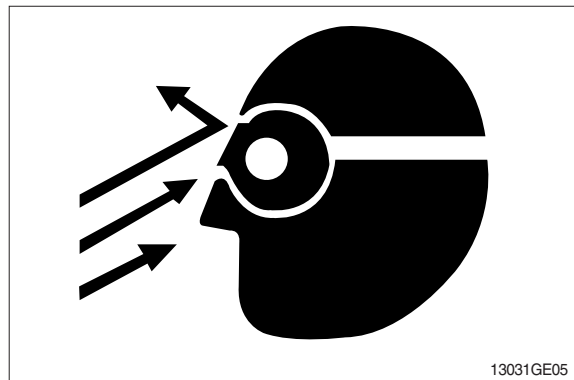

PROTECT AGAINST NOISE

Prolonged exposure to loud noise can cause impairment or loss of hearing.

Wear a suitable hearing protective device such as earmuffs or earplugs to protect against objectionable or uncomfortable loud noises.

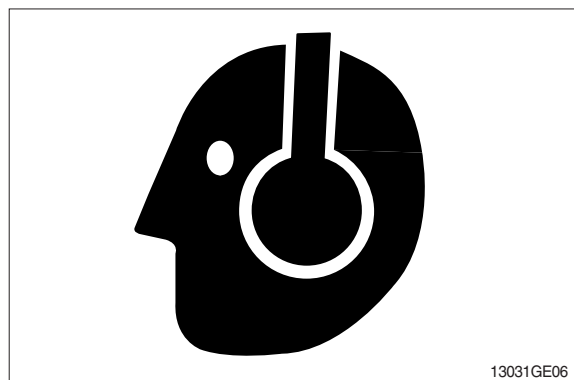

AVOID POWER LINES

Serious injury or death can result from contact with electric lines.

Never move any part of the machine or load closer to electric line than 3m(10ft) plus twice the line insulator length.

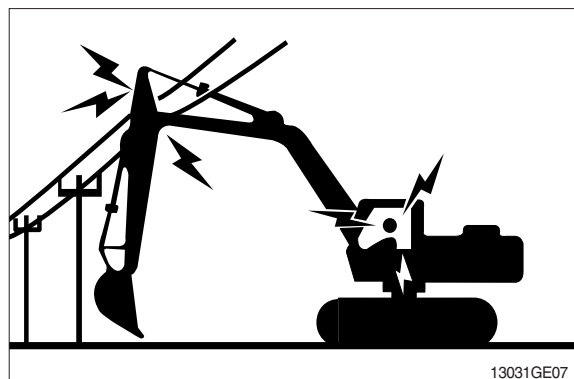

KEEP RIDERS OFF EXCAVATOR

Only allow the operator on the excavator. Keep riders off.

Riders on excavator are subject to injury such as being struck by foreign objects and being thrown off the excavator. Riders also obstruct the operator's view resulting in the excavator being operated in an unsafe manner.

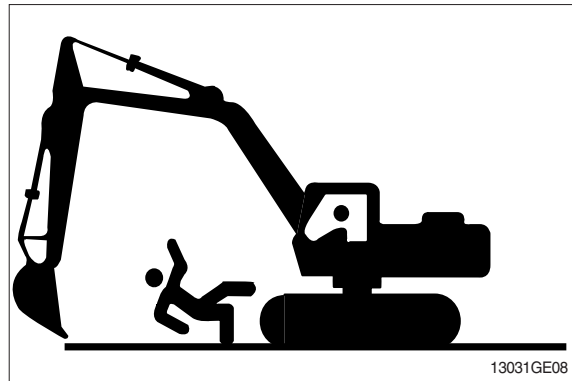

MOVE AND OPERATE MACHINE SAFELY

Bystanders can be run over. Know the location of bystanders before moving, swinging, or operating the machine.

Always keep the travel alarm in working condition. It warns people when the excavator starts to move.

Use a signal person when moving, swinging, or operating the machine in congested areas. Coordinate hand signals before starting the excavator.

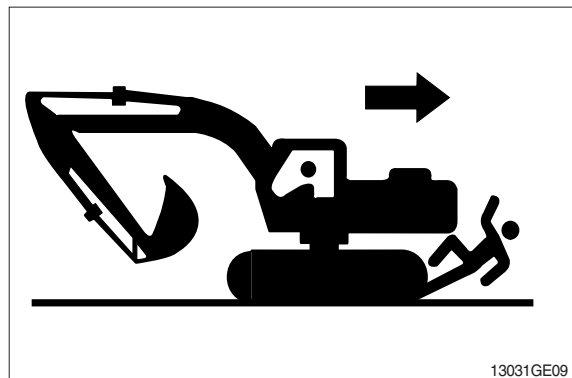

OPERATE ONLY FROM OPERATOR'S SEAT

Avoid possible injury machine damage. Do not start engine by shorting across starter terminals.

NEVER start engine while standing on ground. Start engine only from operator's seat.



PARK MACHINE SAFELY

Before working on the machine:

- Park machine on a level surface.
- Lower bucket to the ground.
- Turn auto idle switch off.
- Run engine at 1/2 speed without load for 2 minutes.
- Turn key switch to OFF to stop engine. Remove key from switch.
- Move pilot control shutoff lever to locked position.
- Allow engine to cool.

SUPPORT MACHINE PROPERLY

Always lower the attachment or implement to the ground before you work on the machine. If you must work on a lifted machine or attachment, securely support the machine or attachment.

Do not support the machine on cinder blocks, hollow tiles, or props that may crumble under continuous load.

Do not work under a machine that is supported solely by a jack. Follow recommended procedures in this manual.

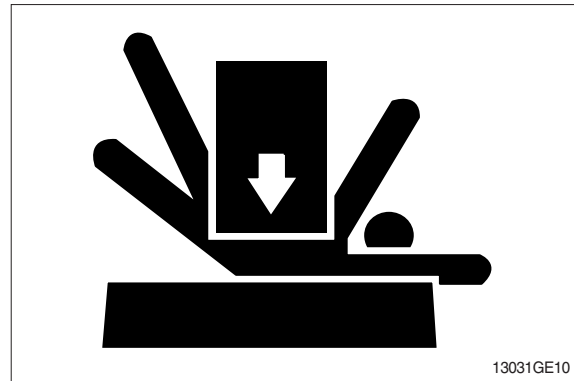

SERVICE COOLING SYSTEM SAFELY

Explosive release of fluids from pressurized cooling system can cause serious burns.

Shut off engine. Only remove filler cap when cool enough to touch with bare hands.

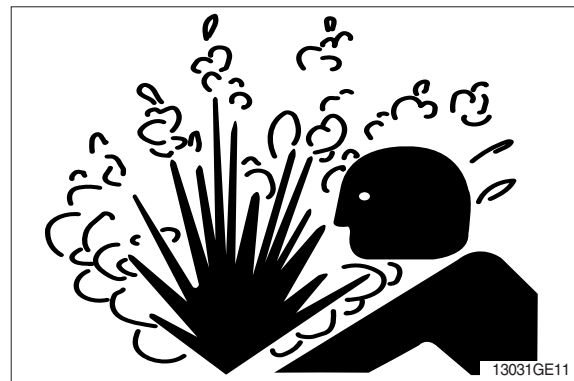

HANDLE FLUIDS SAFELY-AVOID FIRES

Handle fuel with care; It is highly flammable. Do not refuel the machine while smoking or when near open flame or sparks. Always stop engine before refueling machine. Fill fuel tank outdoors.



Store flammable fluids away from fire hazards. Do not incinerate or puncture pressurized containers.

Make sure machine is clean of trash, grease, and debris.

Do not store oily rags; They can ignite and burn spontaneously.

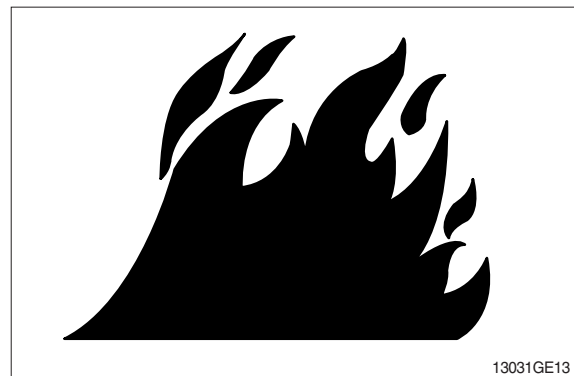

BEWARE OF EXHAUST FUMES

Prevent asphyxiation. Engine exhaust fumes can cause sickness or death.

If you must operate in a building, be positive there is adequate ventilation. Either use an exhaust pipe extension to remove the exhaust fumes or open doors and windows to bring enough outside air into the area.

REMOVE PAINT BEFORE WELDING OR HEATING

Avoid potentially toxic fumes and dust.

Hazardous fumes can be generated when paint is heated by welding, soldering, or using a torch.

Do all work outside or in a well ventilated area. Dispose of paint and solvent properly.

Remove paint before welding or heating:

- If you sand or grind paint, avoid breathing the dust.
Wear an approved respirator.
- If you use solvent or paint stripper, remove stripper with soap and water before welding. Remove solvent or paint stripper containers and other flammable material from area. Allow fumes to disperse at least 15 minutes before welding or heating.

ILLUMINATE WORK AREA SAFELY

Illuminate your work area adequately but safely. Use a portable safety light for working inside or under the machine. Make sure the bulb is enclosed by a wire cage. The hot filament of an accidentally broken bulb can ignite spilled fuel or oil.

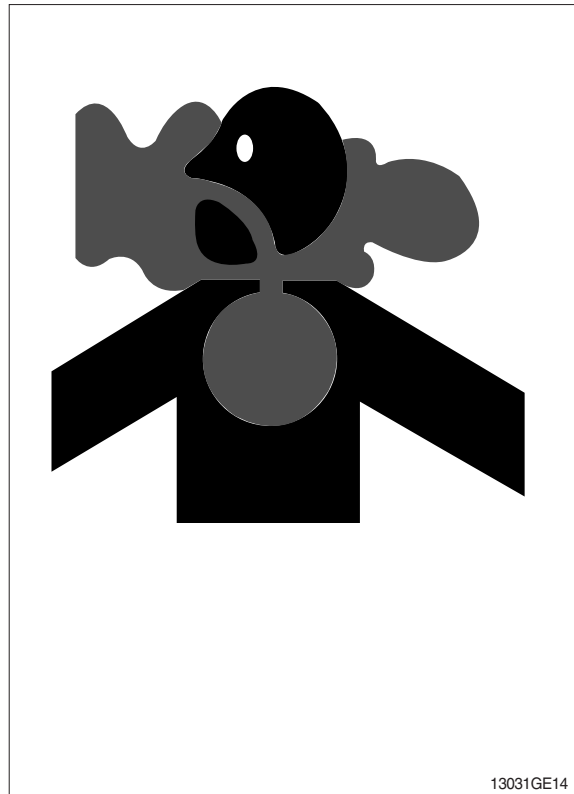

SERVICE MACHINE SAFELY

Tie long hair behind your head. Do not wear a necktie, scarf, loose clothing or necklace when you work near machine tools or moving parts. If these items were to get caught, severe injury could result.

Remove rings and other jewelry to prevent electrical shorts and entanglement in moving parts.

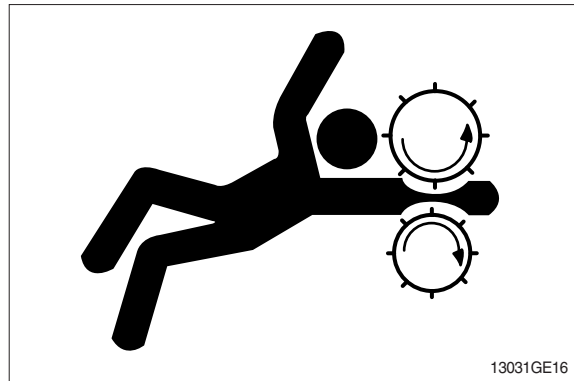

STAY CLEAR OF MOVING PARTS

Entanglements in moving parts can cause serious injury.

To prevent accidents, use care when working around rotating parts.

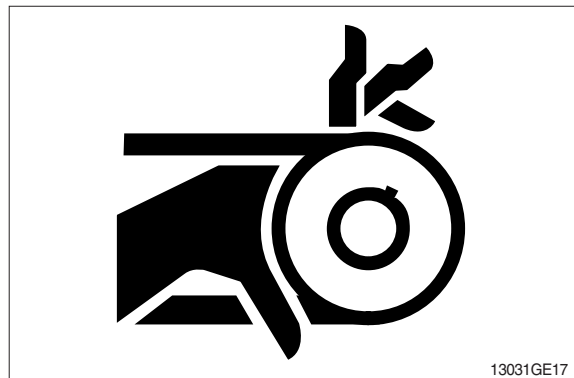

AVOID HIGH PRESSURE FLUIDS

Escaping fluid under pressure can penetrate the skin causing serious injury.

Avoid the hazard by relieving pressure before disconnecting hydraulic or other lines. Tighten all connections before applying pressure.

Search for leaks with a piece of cardboard. Protect hands and body from high pressure fluids.

If an accident occurs, see a doctor immediately. Any fluid injected into the skin must be surgically removed within a few hours or gangrene may result.

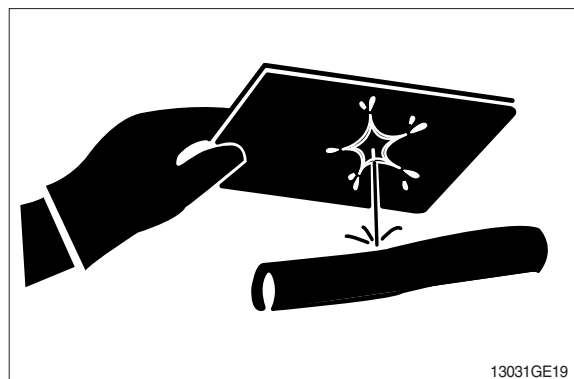

AVOID HEATING NEAR PRESSURIZED FLUID LINES

Flammable spray can be generated by heating near pressurized fluid lines, resulting in severe burns to yourself and bystanders. Do not heat by welding, soldering, or using a torch near pressurized fluid lines or other flammable materials.

Pressurized lines can be accidentally cut when heat goes beyond the immediate flame area. Install fire resisting guards to protect hoses or other materials.



PREVENT BATTERY EXPLOSIONS

Keep sparks, lighted matches, and flame away from the top of battery. Battery gas can explode.

Never check battery charge by placing a metal object across the posts. Use a volt-meter or hydrometer.

Do not charge a frozen battery; It may explode. Warm battery to 16°C (60°F).



PREVENT ACID BURNS

Sulfuric acid in battery electrolyte is poisonous. It is strong enough to burn skin, eat holes in clothing, and cause blindness if splashed into eyes.

Avoid the hazard by:

1. Filling batteries in a well-ventilated area.
2. Wearing eye protection and rubber gloves.
3. Avoiding breathing fumes when electrolyte is added.
4. Avoiding spilling or dripping electrolyte.
5. Use proper jump start procedure.

If you spill acid on yourself:

1. Flush your skin with water.
2. Apply baking soda or lime to help neutralize the acid.
3. Flush your eyes with water for 10-15 minutes. Get medical attention immediately.

If acid is swallowed:

1. Drink large amounts of water or milk.
2. Then drink milk of magnesia, beaten eggs, or vegetable oil.
3. Get medical attention immediately.

USE TOOLS PROPERLY

Use tools appropriate to the work. Makeshift tools, parts, and procedures can create safety hazards.

Use power tools only to loosen threaded tools and fasteners.

For loosening and tightening hardware, use the correct size tools. **DO NOT** use U.S. measurement tools on metric fasteners. Avoid bodily injury caused by slipping wrenches.

Use only recommended replacement parts. (See Parts catalogue.)

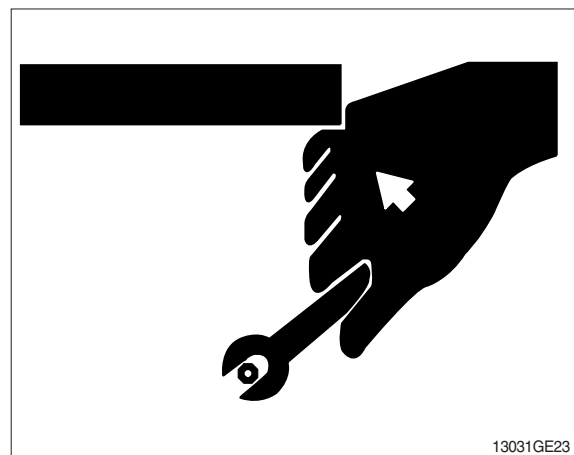
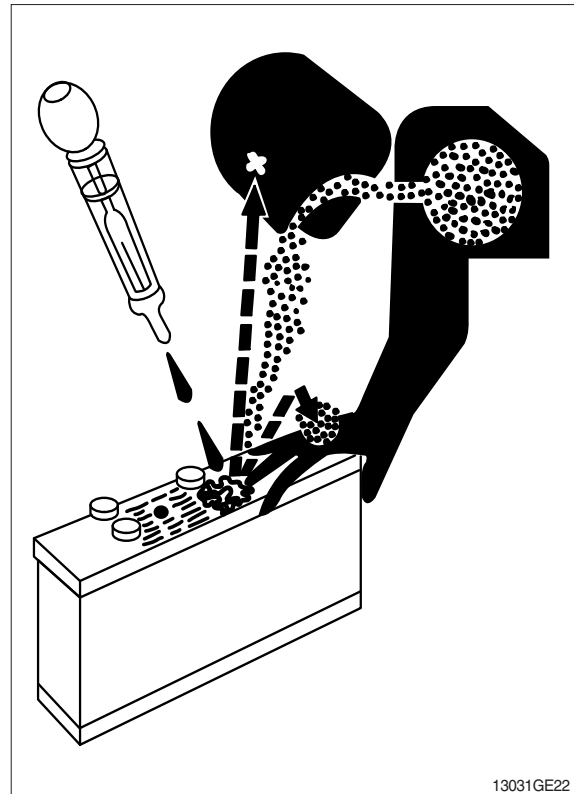

DISPOSE OF FLUIDS PROPERLY

Improperly disposing of fluids can harm the environment and ecology. Before draining any fluids, find out the proper way to dispose of waste from your local environmental agency.

Use proper containers when draining fluids. Do not use food or beverage containers that may mislead someone into drinking from them.

DO NOT pour oil into the ground, down a drain, or into a stream, pond, or lake. Observe relevant environmental protection regulations when disposing of oil, fuel, coolant, brake fluid, filters, batteries, and other harmful waste.

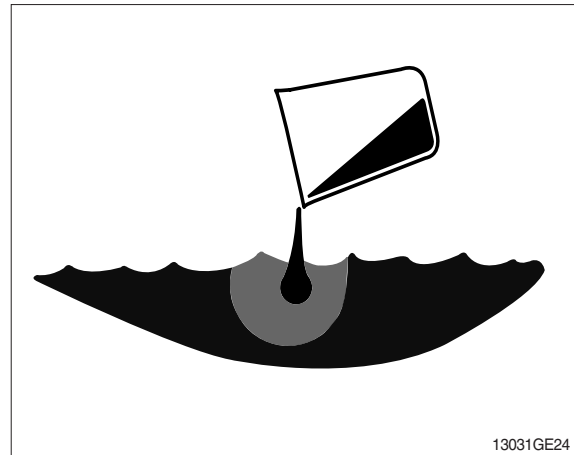

REPLACE SAFETY SIGNS

Replace missing or damaged safety signs. See the machine operator's manual for correct safety sign placement.

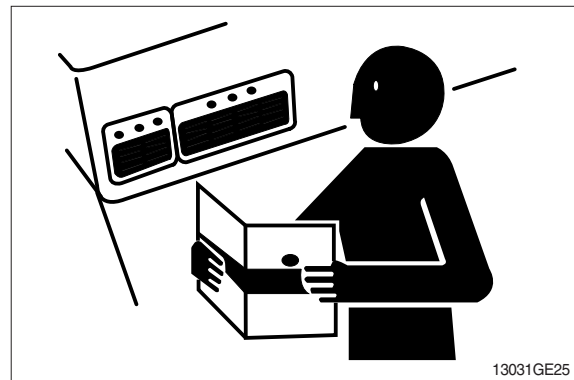

LIVE WITH SAFETY

Before returning machine to customer, make sure machine is functioning properly, especially the safety systems. Install all guards and shields.

GROUP 2 SPECIFICATIONS

1. MAJOR COMPONENT

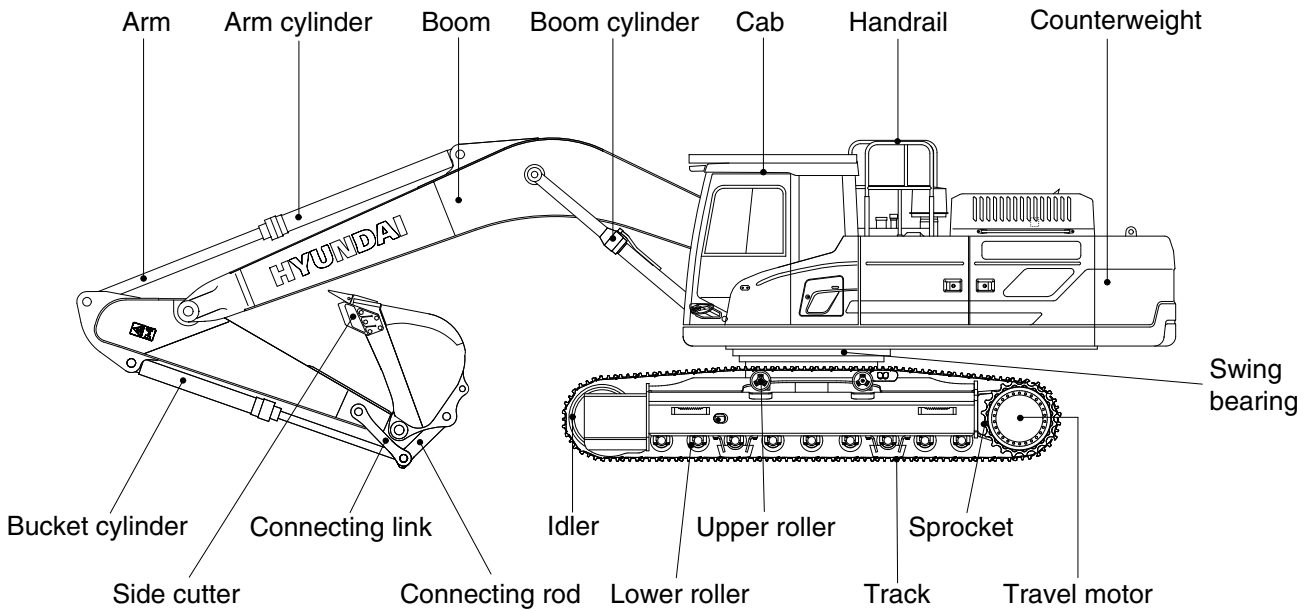
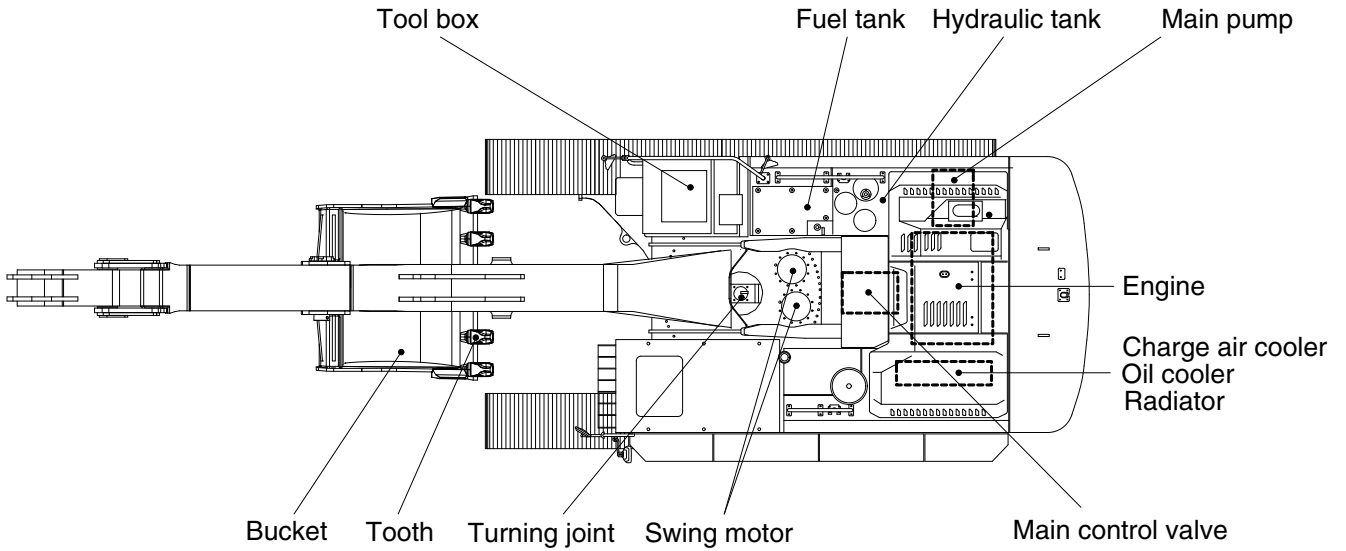

480SA2SP01

2. SPECIFICATIONS

1) HX500LT3 (1/2)

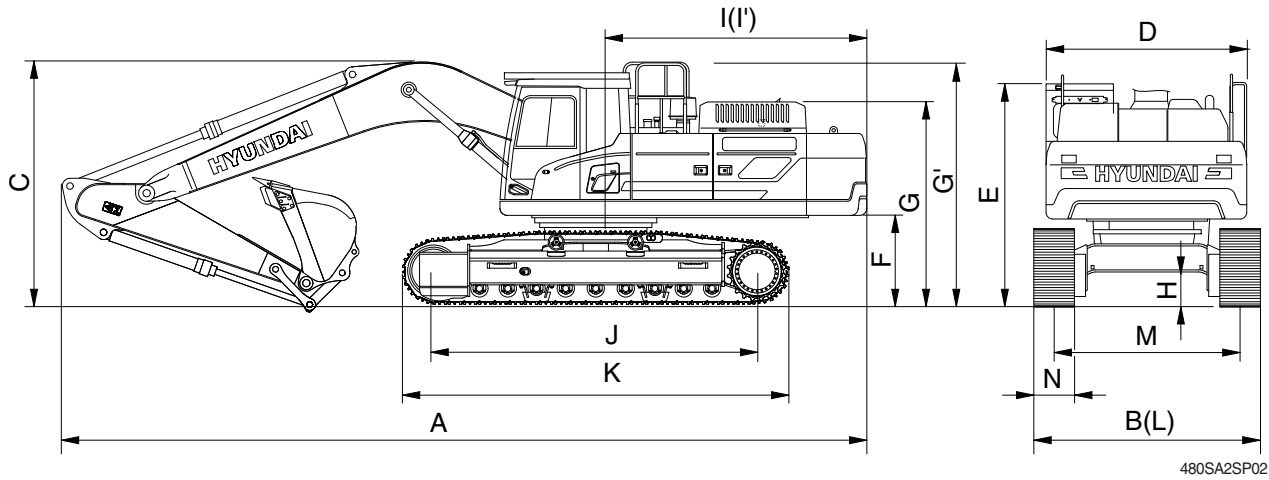

480SA2SP02

Description	Unit		Specification				
	m (ft-in)	Boom	7.06 (23' 2")				
		Arm	3.38 (11' 1")	2.90 (9' 6")	4.00 (13' 1")	2.55 (8' 4")	
	mm (in)	Shoe	600 (24)				
Operating weight	kg (lb)		48860 (107720)	48790 (107560)	48850 (107700)	48620 (107190)	
Bucket capacity (SAE heaped), standard	m ³ (yd ³)		2.20 (2.88)	2.20 (2.88)	2.20 (2.88)	2.20 (2.88)	
Overall length	A	mm (ft-in)	12210 (40' 1")	12220 (40' 1")	12160 (39' 11")	12150 (39' 10")	
Overall width	B		3340 (10' 11")	3340 (10' 11")	3340 (10' 11")	3340 (10' 11")	
Overall height of boom	C		3790 (12' 5")	3850 (12' 8")	3850 (12' 8")	3890 (12' 9")	
Superstructure width	D		2980 (9' 9")	2980 (9' 9")	2980 (9' 9")	2980 (9' 9")	
Overall height of cab	E		3240 (10' 8")	3240 (10' 8")	3240 (10' 8")	3240 (10' 8")	
Ground clearance of counterweight	F		1370 (4' 6")	1370 (4' 6")	1370 (4' 6")	1370 (4' 6")	
Overall height of engine hood	G		3140 (10' 4")	3140 (10' 4")	3140 (10' 4")	3140 (10' 4")	
Overall height of handrail	G'		3610 (11' 10")	3610 (11' 10")	3610 (11' 10")	3610 (11' 10")	
Minimum ground clearance	H		585 (1' 11")	585 (1' 11")	585 (1' 11")	585 (1' 11")	
Rear-end distance	I		3745 (12' 3")	3745 (12' 3")	3745 (12' 3")	3745 (12' 3")	
Rear-end swing radius	I'		3800 (12' 6")	3800 (12' 6")	3800 (12' 6")	3800 (12' 6")	
Distance between tumblers	J		4470 (14' 8")	4470 (14' 8")	4470 (14' 8")	4470 (14' 8")	
Undercarriage length (without grouser)	K		5416 (17' 9")	5416 (17' 9")	5416 (17' 9")	5416 (17' 9")	
Undercarriage length (with grouser)	K		5490 (18' 0")	5490 (18' 0")	5490 (18' 0")	5490 (18' 0")	
Undercarriage width	L		3340 (10' 11")	3340 (10' 11")	3340 (10' 11")	3340 (10' 11")	
Track gauge	M		2740 (9' 0")	2740 (9' 0")	2740 (9' 0")	2740 (9' 0")	
Track shoe width, standard	N		600 (24")	600 (24")	600 (24")	600 (24")	
Travel speed (low/high)	km/hr (mph)			3.2/5.2 (2.0/3.2)	3.2/5.2 (2.0/3.2)	3.2/5.2 (2.0/3.2)	3.2/5.2 (2.0/3.2)
Swing speed	rpm			8.8	8.8	8.8	8.8
Gradeability	Degree (%)			35 (70)	35 (70)	35 (70)	35 (70)
Ground pressure	kgf/cm ² (psi)		0.85 (12.1)	0.85 (12.1)	0.85 (12.1)	0.84 (12.0)	
Max traction force	kg (lb)		39674 (87466)	39674 (87466)	39674 (87466)	39674 (87466)	

2) HX500LT3 (2/2)

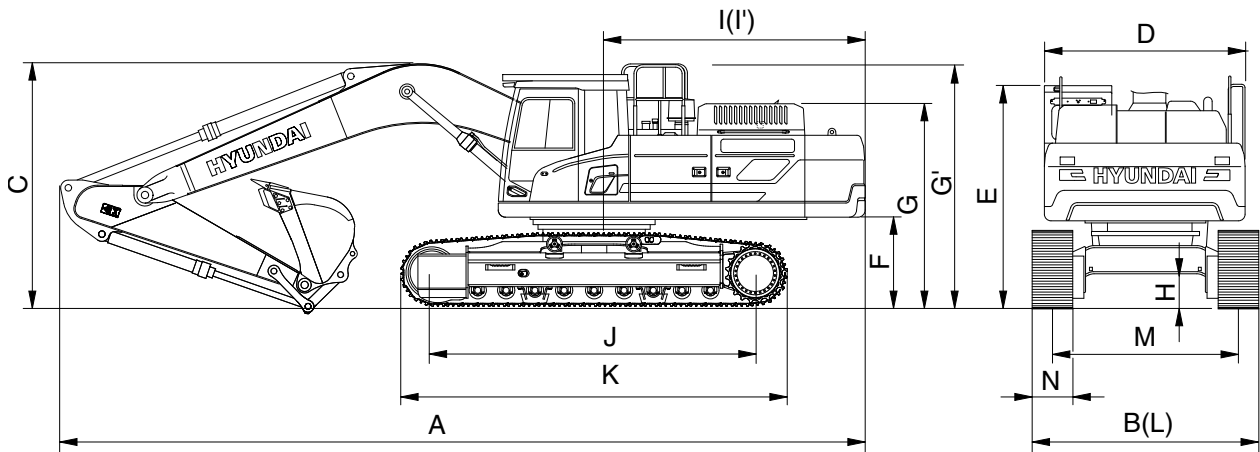

480SA2SP02

Description	Unit		Specification		
	m (ft-in)	Boom	6.55 (21' 6")	9.00 (29' 6")	
		Arm	2.55 (8' 4")	6.00 (19' 8")	
mm (in)	Shoe	600 (24)			
Operating weight	kg (lb)		48430 (106770)	49690 (109550)	
Bucket capacity (SAE heaped), standard	m ³ (yd ³)		2.20 (2.88)	1.38 (1.80)	
Overall length	A	mm (ft-in)	11680 (38' 4")	14070 (46' 2")	
Overall width	B		3340 (10' 11")	3340 (10' 11")	
Overall height of boom	C		3790 (12' 5")	3970 (13' 0")	
Superstructure width	D		2980 (9' 9")	2980 (9' 9")	
Overall height of cab	E		3240 (10' 8")	3240 (10' 8")	
Ground clearance of counterweight	F		1370 (4' 6")	1370 (4' 6")	
Overall height of engine hood	G		3140 (10' 4")	3140 (10' 4")	
Overall height of handrail	G'		3610 (11' 10")	3610 (11' 10")	
Minimum ground clearance	H		585 (1' 11")	585 (1' 11")	
Rear-end distance	I		3745 (12' 3")	3745 (12' 3")	
Rear-end swing radius	I'		3800 (12' 6")	3800 (12' 6")	
Distance between tumblers	J		4470 (14' 8")	4470 (14' 8")	
Undercarriage length (without grouser)	K		5416 (17' 9")	5416 (17' 9")	
Undercarriage length (with grouser)	K		5490 (18' 0")	5490 (18' 0")	
Undercarriage width	L		3340 (10' 11")	3340 (10' 11")	
Track gauge	M		2740 (9' 0")	2740 (9' 0")	
Track shoe width, standard	N		600 (24")	600 (24")	
Travel speed (low/high)	km/hr (mph)		3.2/5.2 (2.0/3.2)	3.2/5.2 (2.0/3.2)	
Swing speed	rpm		8.8	8.8	
Gradeability	Degree (%)		35 (70)	35 (70)	
Ground pressure	kgf/cm ² (psi)		0.84 (12.0)	0.86 (12.3)	
Max traction force	kg (lb)		39674 (87466)	39674 (87466)	

3) HX520LT3 (1/2)

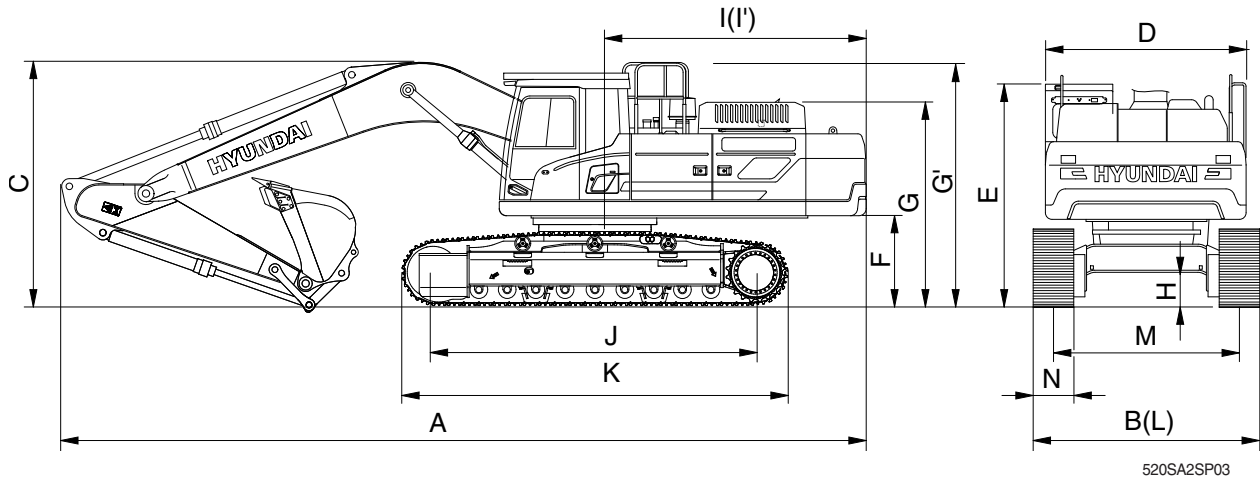

520SA2SP03

Description	Unit		Specification			
	m (ft-in)	Boom	7.06 (23' 2")			
		Arm	3.38 (11' 1")	2.90 (9' 6")	4.00 (13' 1")	2.55 (8' 4")
	mm (in)	Shoe	600 (24)			
Operating weight	kg (lb)		51390 (113300)	51320 (113140)	51380 (113270)	51140 (112740)
Bucket capacity (SAE heaped), standard	m ³ (yd ³)		2.20 (2.88)	2.20 (2.88)	2.20 (2.88)	2.20 (2.88)
Overall length	A	mm (ft-in)	12200 (40' 0")	12210 (40' 1")	12160 (39' 11")	12150 (39' 10")
Overall width (transport position)	B		2980 (9' 9")	2980 (9' 9")	2980 (9' 9")	2980 (9' 9")
Overall width (working position)	B		3540 (11' 7")	3540 (11' 7")	3540 (11' 7")	3540 (11' 7")
Overall height of boom	C		3830 (12' 7")	3890 (12' 9")	3850 (12' 8")	3980 (13' 1")
Superstructure width	D		2980 (9' 9")	2980 (9' 9")	2980 (9' 9")	2980 (9' 9")
Overall height of cab	E		3385 (11' 1")	3385 (11' 1")	3385 (11' 1")	3385 (11' 1")
Ground clearance of counterweight	F		1445 (4' 9")	1445 (4' 9")	1445 (4' 9")	1445 (4' 9")
Overall height of engine hood	G		3140 (10' 4")	3140 (10' 4")	3140 (10' 4")	3140 (10' 4")
Overall height of handrail	G'		3600 (11' 10")	3600 (11' 10")	3600 (11' 10")	3600 (11' 10")
Minimum ground clearance	H		780 (2' 7")	780 (2' 7")	780 (2' 7")	780 (2' 7")
Rear-end distance	I		3745 (12' 3")	3745 (12' 3")	3745 (12' 3")	3745 (12' 3")
Rear-end swing radius	I'		3800 (12' 6")	3800 (12' 6")	3800 (12' 6")	3800 (12' 6")
Distance between tumblers	J		4470 (14' 8")	4470 (14' 8")	4470 (14' 8")	4470 (14' 8")
Undercarriage length (transport position)	K		5416 (17' 9")	5416 (17' 9")	5416 (17' 9")	5416 (17' 9")
Undercarriage length (working position)	K		5490 (18' 0")	5490 (18' 0")	5490 (18' 0")	5490 (18' 0")
Undercarriage width (transport position)	L		2980 (9' 9")	2980 (9' 9")	2980 (9' 9")	2980 (9' 9")
Undercarriage width (working position)	L		3540 (11' 7")	3540 (11' 7")	3540 (11' 7")	3540 (11' 7")
Track gauge (transport position)	M		2380 (7' 10")	2380 (7' 10")	2380 (7' 10")	2380 (7' 10")
Track gauge (working position)	M		2940 (9' 8")	2940 (9' 8")	2940 (9' 8")	2940 (9' 8")
Track shoe width, standard	N		600 (24")	600 (24")	600 (24")	600 (24")
Travel speed (low/high)	km/hr (mph)		3.2/5.2 (2.0/3.2)	3.2/5.2 (2.0/3.2)	3.2/5.2 (2.0/3.2)	3.2/5.2 (2.0/3.2)
Swing speed	rpm		8.8	8.8	8.8	8.8
Gradeability	Degree (%)		35 (70)	35 (70)	35 (70)	35 (70)
Ground pressure	kgf/cm ² (psi)		0.89 (12.7)	0.89 (12.7)	0.89 (12.7)	0.89 (12.6)
Max traction force	kg (lb)		39674 (87466)	39674 (87466)	39674 (87466)	34100 (87466)

4) HX520LT3 (2/2)

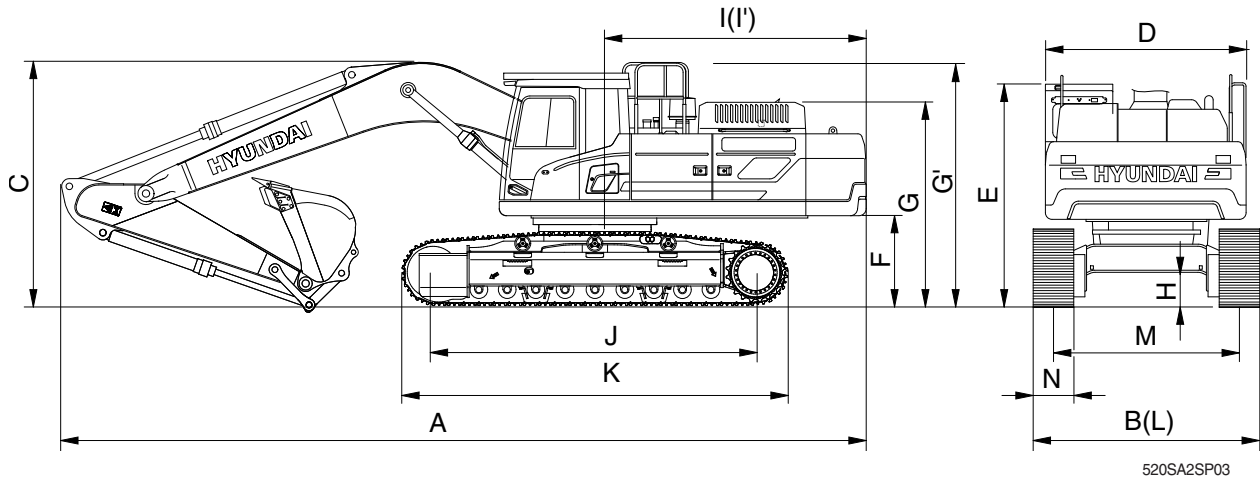

Description	Unit		Specification			
	m (ft-in)	Boom	6.55 (21' 6")			9.00 (29' 6")
		Arm	3.38 (11' 1")	2.90 (9' 6")	2.55 (8' 4")	6.00 (19' 8")
mm (in)	Shoe	600 (24)				
Operating weight	kg (lb)	51200 (112880)	51130 (112720)	50960 (112350)	52200 (115080)	
Bucket capacity (SAE heaped), standard	m ³ (yd ³)	2.20 (2.88)	2.20 (2.88)	2.20 (2.88)	1.38 (1.80)	
Overall length	A	11680 (38' 4")	11690 (38' 4")	11650 (38' 3")	14080 (46' 2")	
Overall width (transport position)	B	2980 (9' 9")	2980 (9' 9")	2980 (9' 9")	2980 (9' 9")	
Overall width (working position)	B	3540 (11' 7")	3540 (11' 7")	3540 (11' 7")	3540 (11' 7")	
Overall height of boom	C	3920 (12' 10")	3970 (13' 0")	3900 (12' 10")	3970 (13' 0")	
Superstructure width	D	2980 (9' 9")	2980 (9' 9")	2980 (9' 9")	2980 (9' 9")	
Overall height of cab	E	3385 (11' 1")	3385 (11' 1")	3385 (11' 1")	3385 (11' 1")	
Ground clearance of counterweight	F	1445 (4' 9")	1445 (4' 9")	1445 (4' 9")	1445 (4' 9")	
Overall height of engine hood	G	3140 (10' 4")	3140 (10' 4")	3140 (10' 4")	3140 (10' 4")	
Overall height of handrail	G'	3600 (11' 10")	3600 (11' 10")	3600 (11' 10")	3600 (11' 10")	
Minimum ground clearance	H	770 (2' 6")	770 (2' 6")	770 (2' 6")	770 (2' 6")	
Rear-end distance	I	3745 (12' 3")	3745 (12' 3")	3745 (12' 3")	3745 (12' 3")	
Rear-end swing radius	I'	3800 (12' 6")	3800 (12' 6")	3800 (12' 6")	3800 (12' 6")	
Distance between tumblers	J	4470 (14' 8")	4470 (14' 8")	4470 (14' 8")	4470 (14' 8")	
Undercarriage length (transport position)	K	5416 (17' 9")	5416 (17' 9")	5416 (17' 9")	5416 (17' 9")	
Undercarriage length (working position)	K	5490 (18' 0")	5490 (18' 0")	5490 (18' 0")	5490 (18' 0")	
Undercarriage width (transport position)	L	2980 (9' 9")	2980 (9' 9")	2980 (9' 9")	2980 (9' 9")	
Undercarriage width (working position)	L	3540 (11' 7")	3540 (11' 7")	3540 (11' 7")	3540 (11' 7")	
Track gauge (transport position)	M	2380 (7' 10")	2380 (7' 10")	2380 (7' 10")	2380 (7' 10")	
Track gauge (working position)	M	2940 (9' 8")	2940 (9' 8")	2940 (9' 8")	2940 (9' 8")	
Track shoe width, standard	N	600 (24")	600 (24")	600 (24")	600 (24")	
Travel speed (low/high)	km/hr (mph)	3.2/5.2 (2.0/3.2)	3.2/5.2 (2.0/3.2)	3.2/5.2 (2.0/3.2)	3.2/5.2 (2.0/3.2)	
Swing speed	rpm	8.8	8.8	8.8	8.8	
Gradeability	Degree (%)	35 (70)	35 (70)	35 (70)	35 (70)	
Ground pressure	kgf/cm ² (psi)	0.89 (12.6)	0.89 (12.6)	0.89 (12.6)	0.91 (12.9)	
Max traction force	kg (lb)	39674 (87466)	39674 (87466)	39674 (87466)	34100 (87466)	

3. WORKING RANGE AND DIGGING FORCE

1) HX500LT3 (1/2)

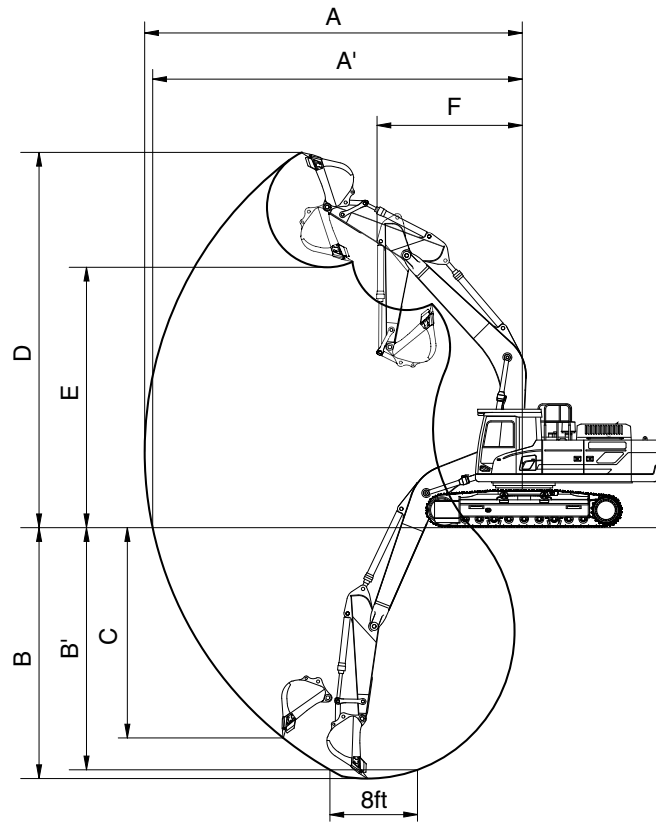

480SA2SP05

Description	m (ft-in)	Boom	7.06 (23' 2")			
		Arm	2.55 (8' 4")	2.90 (9' 6")	3.38 (11' 1")	4.00 (13' 1")
Max digging reach	mm (ft-in)	A	11410 (37' 5")	11670 (38' 3")	12060 (39' 7")	12610 (41' 4")
Max digging reach on ground		A'	11190 (36' 9")	11460 (37' 7")	11850 (38' 11")	12410 (40' 9")
Max digging depth		B	6900 (22' 8")	7250 (23' 9")	7730 (25' 4")	8350 (27' 5")
Max digging depth (8 ft level)		B'	6730 (22' 1")	7090 (23' 3")	7590 (24' 11")	8220 (27' 0")
Max vertical wall digging depth		C	5280 (17' 4")	5710 (18' 9")	5490 (18' 0")	6170 (20' 3")
Max digging height		D	11070 (36' 4")	11090 (36' 5")	11060 (36' 3")	11330 (37' 2")
Max dumping height		E	7600 (24' 11")	7630 (25' 0")	7710 (25' 4")	7920 (26' 0")
Min swing radius		F	4820 (15' 10")	4880 (16' 0")	4870 (16' 0")	4630 (15' 2")
Bucket digging force	kN	SAE	212.8 [231.0]	212.8 [231.0]	212.8 [231.0]	212.8 [231.0]
	kgf		21700 [23560]	21700 [23560]	21700 [23560]	21700 [23560]
	lbf		47840 [51941]	47840 [51941]	47840 [51941]	47840 [51941]
	kN	ISO	247.1 [268.3]	247.1 [268.3]	247.1 [268.3]	247.1 [268.3]
	kgf		25200 [27360]	25200 [27360]	25200 [27360]	25200 [27360]
	lbf		55556 [60318]	55556 [60318]	55556 [60318]	55556 [60318]
Arm digging force	kN	SAE	235.4 [255.6]	218.7 [237.4]	198.1 [215.1]	173.6 [188.5]
	kgf		24000 [26060]	22300 [24210]	20200 [21930]	17700 [19220]
	lbf		52911 [57452]	49163 [53374]	44533 [48347]	39022 [42373]
	kN	ISO	246.1 [267.2]	227.5 [247.0]	205.0 [222.5]	179.5 [194.9]
	kgf		25100 [27250]	23200 [25190]	20900 [22690]	18300 [19870]
	lbf		55336 [60076]	51147 [55534]	46077 [50023]	40345 [43806]

[] : Power boost

2) HX500LT3 (2/2)

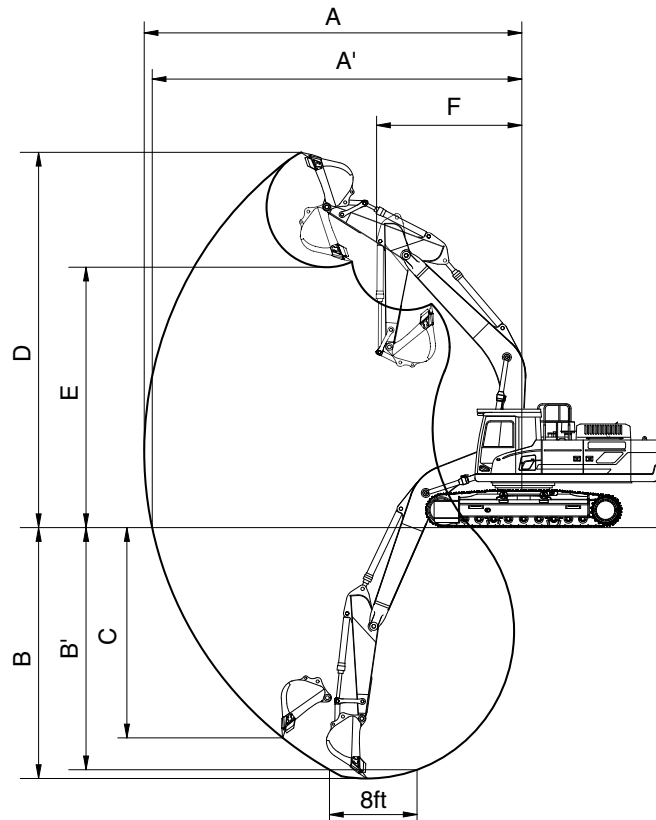

480SA2SP05

Description	m (ft-in)	Boom	6.55 (21' 6")	9.00 (29' 6")
		Arm	2.55 (8' 4")	6.00 (19' 8")
Max digging reach	mm (ft-in)	A	10870 (35' 8")	16110 (52' 10")
Max digging reach on ground		A'	10640 (34' 11")	15950 (52' 4")
Max digging depth		B	6460 (21' 2")	11710 (38' 5")
Max digging depth (8 ft level)		B'	6290 (20' 8")	11620 (38' 1")
Max vertical wall digging depth		C	4840 (15' 11")	8660 (28' 5")
Max digging height		D	10670 (35' 0")	13100 (43' 0")
Max dumping height		E	7210 (23' 8")	9800 (32' 2")
Min swing radius		F	4440 (14' 7")	5630 (18' 6")
Bucket digging force	kN	SAE	240.3 [260.9]	212.8 -
	kgf		24500 [26600]	21700 -
	lbf		54013 [58643]	47840 -
	kN	ISO	279.5 [303.4]	247.1 -
	kgf		28500 [30940]	25200 -
	lbf		62832 [68211]	55556 -
Arm digging force	kN	SAE	235.4 [255.6]	127.5 -
	kgf		24000 [26060]	13000 -
	lbf		52911 [57452]	28660 -
	kN	ISO	246.1 [267.2]	130.4 -
	kgf		25100 [27250]	13300 -
	lbf		55336 [60076]	29321 -

[] : Power boost

3) HX520LT3 (1/2)

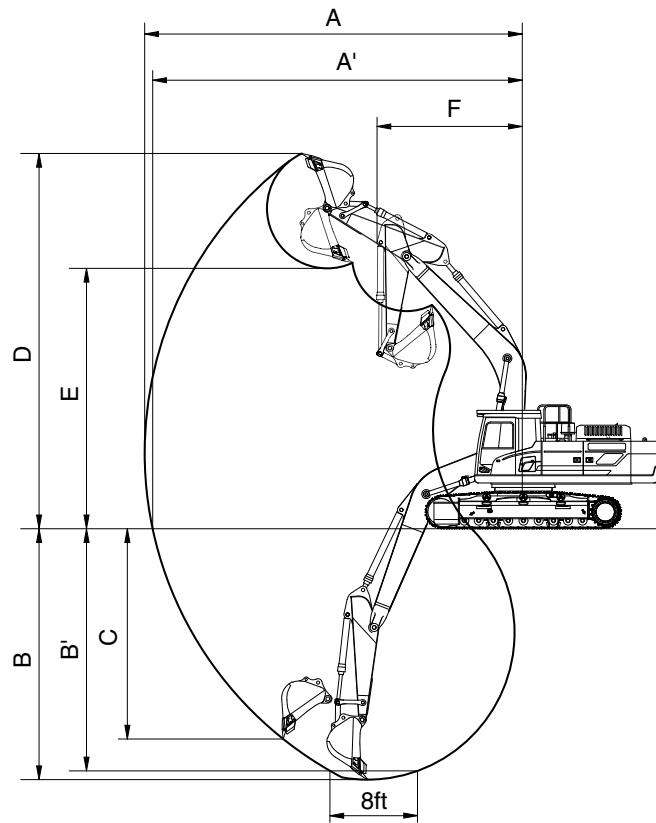

520SA2SP06

Description	m (ft-in)	Boom	7.06 (23' 2")			
		Arm	2.55 (8' 4")	2.90 (9' 6")	3.38 (11' 1")	4.00 (13' 1")
Max digging reach	mm (ft-in)	A	11410 (37' 5")	11670 (38' 3")	12060 (39' 7")	12610 (41' 4")
Max digging reach on ground		A'	11170 (36' 8")	11440 (37' 6")	11840 (38' 10")	12400 (40' 8")
Max digging depth		B	6820 (22' 5")	7170 (23' 6")	7650 (25' 1")	8270 (27' 2")
Max digging depth (8 ft level)		B'	6650 (21' 10")	7010 (23' 0")	7510 (24' 8")	8140 (26' 8")
Max vertical wall digging depth		C	5200 (17' 1")	5630 (18' 6")	5410 (17' 9")	6090 (20' 0")
Max digging height		D	11150 (36' 7")	11170 (36' 8")	11140 (36' 7")	11410 (37' 5")
Max dumping height		E	7680 (25' 2")	7710 (25' 4")	7790 (25' 7")	8000 (26' 3")
Min swing radius		F	4820 (15' 10")	4880 (16' 0")	4870 (16' 0")	4630 (15' 2")
Bucket digging force	kN		240.3 [260.9]	240.3 [260.9]	240.3 [260.9]	240.3 [260.9]
	kgf	SAE	24500 [26600]	24500 [26600]	24500 [26600]	24500 [26600]
	lbf		54013 [58643]	54013 [58643]	54013 [58643]	54013 [58643]
	kN		279.5 [303.4]	279.5 [303.4]	279.5 [303.4]	279.5 [303.4]
	kgf	ISO	28500 [30940]	28500 [30940]	28500 [30940]	28500 [30940]
	lbf		62832 [68211]	62832 [68211]	62832 [68211]	62832 [68211]
Arm digging force	kN		235.4 [255.6]	218.7 [237.4]	198.1 [215.1]	173.6 [188.5]
	kgf	SAE	24000 [26060]	22300 [24210]	20200 [21930]	17700 [19220]
	lbf		52911 [57452]	49163 [53374]	44533 [48347]	39022 [42373]
	kN		246.1 [267.2]	227.5 [247.0]	205.0 [222.5]	179.5 [194.9]
	kgf	ISO	25100 [27250]	23200 [25190]	20900 [22690]	18300 [19870]
	lbf		55336 [60076]	51147 [55534]	46077 [50023]	40345 [43806]

[] : Power boost

4) HX520LT3 (2/2)

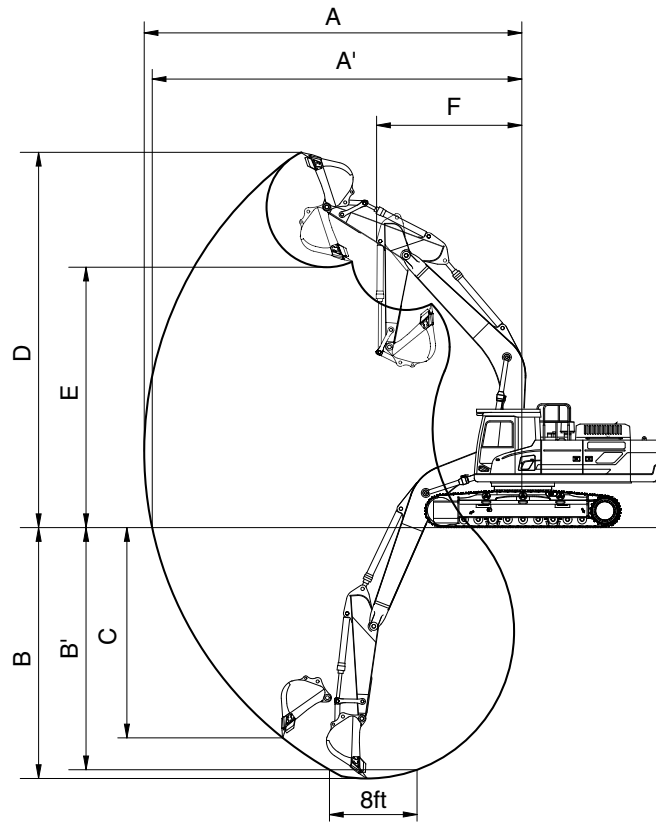

520SA2SP06

Description	m (ft-in)	Boom	6.55 (21' 6")			9.00 (29' 6")
		Arm	2.55 (8' 4")	2.90 (9' 6")	3.38 (11' 1")	6.00 (19' 8")
Max digging reach	mm (ft-in)	A	10870 (35' 8")	11130 (36' 6")	11520 (37' 10")	16110 (52' 10")
Max digging reach on ground		A'	10610 (34' 10")	10890 (35' 9")	11280 (37' 0")	15940 (52' 4")
Max digging depth		B	6380 (20' 11")	6730 (22' 1")	7210 (23' 8")	11550 (37' 11")
Max digging depth (8 ft level)		B'	6210 (20' 4")	6570 (21' 7")	7070 (23' 2")	11450 (37' 7")
Max vertical wall digging depth		C	4760 (15' 7")	4820 (15' 10")	4990 (16' 4")	8580 (28' 2")
Max digging height		D	10760 (35' 4")	10710 (35' 2")	10740 (35' 3")	13180 (43' 3")
Max dumping height		E	7290 (23' 11")	7320 (24' 0")	7400 (24' 3")	9880 (32' 5")
Min swing radius		F	4440 (14' 7")	4450 (14' 7")	4490 (14' 9")	5630 (18' 6")
Bucket digging force	kN	SAE	240.3 [260.9]	240.3 [260.9]	240.3 [260.9]	212.8 -
	kgf		24500 [26600]	24500 [26600]	24500 [26600]	21700 -
	lbf		54013 [58643]	54013 [58643]	54013 [58643]	47840 -
	kN	ISO	279.5 [303.4]	279.5 [303.4]	279.5 [303.4]	247.1 -
	kgf		28500 [30940]	28500 [30940]	28500 [30940]	25200 -
	lbf		62832 [68211]	62832 [68211]	62832 [68211]	55556 -
Arm digging force	kN	SAE	235.4 [255.6]	218.7 [237.4]	198.1 [215.1]	127.5 -
	kgf		24000 [26060]	22300 [24210]	20200 [21930]	13000 -
	lbf		52911 [57452]	49163 [53374]	44533 [48347]	28660 -
	kN	ISO	246.1 [267.2]	227.5 [247.0]	205.0 [222.5]	130.4 -
	kgf		25100 [27250]	23200 [25190]	20900 [22690]	13300 -
	lbf		55336 [60076]	51147 [55534]	46077 [50023]	29321 -

[] : Power boost

4. WEIGHT

Item	HX500LT3		HX520LT3	
	kg	lb	kg	lb
Upperstructure assembly				
· Main frame weld assembly	4313	9508	4313	9508
· Engine assembly	860	1896	860	1896
· Main pump assembly	194	428	194	428
· Main control valve assembly	421	928	421	928
· Swing motor assembly	667	1470	667	1470
· Hydraulic oil tank WA	418	922	418	922
· Fuel tank WA	376	829	376	829
· Counterweight	9700	21385	10700	23589
· Cab assembly	495	1092	495	1092
Lower chassis assembly				
· Track frame weld assembly	6600	14550	7888	17390
· Swing bearing	719	1585	719	1585
· Travel motor assembly (2EA)	1264	2787	1264	2787
· Turning joint	96	212	96	212
· Sprocket (2EA)	188	415	188	415
· Track recoil spring (2EA)	653	1440	653	1440
· Idler (2EA)	639	1408	639	1408
· Upper roller (HX500LT3 - 4EA / HX520LT3 - 6EA)	351	774	244	538
· Lower roller (18EA)	1579	3481	1531	3375
· Track-chain assembly (600 mm triple grouser shoe) (2EA)	5534	12200	5534	12200
· Track-chain assembly (700 mm triple grouser shoe) (2EA)	6054	13347	6054	13347
· Track-chain assembly (800 mm triple grouser shoe) (2EA)	6584	14515	6584	14515
· Track-chain assembly (900 mm triple grouser shoe) (2EA)	7092	15635	7092	15635
· Track-chain assembly (600 mm double grouser shoe) (2EA)	5566	12271	5566	12271
· Track-chain assembly (600 mm HD triple grouser shoe) (2EA)	5714	12597	5714	12597
Front attachment assembly				
· 7.06 m boom assembly	3640	8025	3640	8025
· 3.38 m arm assembly	1845	4067	1845	4067
· 2.20 m³ SAE heaped bucket	2020	4453	2020	4453
· Boom cylinder assembly (2EA)	1142	2518	1142	2518
· Arm cylinder assembly	591	1303	591	1303
· Bucket cylinder assembly	366	807	366	807
· Bucket control linkage total	519	1144	519	1144

※ This information is different with operating and transportation weight because it is not including harness, pipe, oil, fuel so on.

※ Refer to Transportation for actual weight information and Specifications for operating weight.

5. LIFTING CAPACITIES









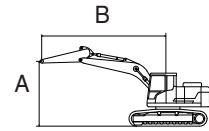

1) HX500LT3

Model	Type	Boom	Arm	Counterweight	Shoe	Wheel	Dozer		Outrigger	
		Length [mm]	Length [mm]	weight [kg]	width [mm]	width [mm]	Front	Rear	Front	Rear
HX500LT3	MONO BOOM	6550	2550	9200	600	-	-	-	-	-

·  : Rating over-front

·  : Rating over-side or 360 degree



Lift-point height (A)	Lift-point radius (B)								At max. reach		
	3.0 m (9.8 ft)		4.5 m (14.8 ft)		6.0 m (19.7 ft)		7.5 m (24.6 ft)		Capacity		Reach
											m (ft)
9.0 m (29.5 ft)	kg								*13880	*13880	5.79
	lb								*30600	*30600	(19.0)
7.5 m (24.6 ft)	kg				*13190	*13190			*12600	10960	7.22
	lb				*29080	*29080			*27780	24160	(23.7)
6.0 m (19.7 ft)	kg				*13980	*13980	*12410	10200	*12070	8900	8.12
	lb				*30820	*30820	*27360	22490	*26610	19620	(26.6)
4.5 m (14.8 ft)	kg		*20370	*20370	*15430	13870	*12960	9900	*11830	7840	8.67
	lb		*44910	*44910	*34020	30580	*28570	21830	*26080	17280	(28.4)
3.0 m (9.8 ft)	kg				*16960	13100	*13650	9520	*11730	7320	8.94
	lb				*37390	28880	*30090	20990	*25860	16140	(29.3)
1.5 m (4.9 ft)	kg				*17890	12510	*14120	9190	*11690	7170	8.94
	lb				*39440	27580	*31130	20260	*25770	15810	(29.3)
0.0 m (0.0 ft)	kg		*21030	18620	*17850	12210	*14030	8990	*11620	7390	8.69
	lb		*46360	41050	*39350	26920	*30930	19820	*25620	16290	(28.5)
-1.5 m (-4.9 ft)	kg	*15060	*15060	*21280	18720	*16720	12170	*13030	8970	*11390	8.15
	lb	*33200	*33200	*46910	41270	*36860	26830	*28730	19780	*25110	(26.7)
-3.0 m (-9.8 ft)	kg	*20530	*20530	*17830	*17830	*14160	12360		*10720	9590	7.26
	lb	*45260	*45260	*39310	*39310	*31220	27250		*23630	21140	(23.8)

Note 1. Lifting capacity are based on ISO 10567.

2. Lifting capacity of the HX series does not exceed 75% of tipping load with the machine on firm, level ground or 87% of full hydraulic capacity.

3. The Lift-point is bucket pivot mounting pin on the arm (without bucket mass).

4. *Indicates load limited by hydraulic capacity.

※ Lifting capacities are based upon a standard machine conditions.

Lifting capacities will vary with different work tools, ground conditions and attachments.

The difference between the weight of a work tool attachment must be subtracted.

Consult with your local Hyundai dealer regarding the lifting capacities for specific work tools and attachments.









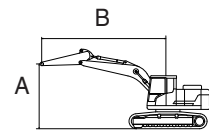





▲ Failure to comply to the rated load can cause serious injury, death, or property damage. Make adjustments to the rated load as necessary for non-standard configurations.

Model	Type	Boom	Arm	Counterweight	Shoe	Wheel	Dozer		Outrigger	
		Length [mm]	Length [mm]	weight [kg]	width [mm]	width [mm]	Front	Rear	Front	Rear
HX500LT3	MONO BOOM	6550	2900	9200	600	-	-	-	-	-

·  : Rating over-front

·  : Rating over-side or 360 degree



Lift-point height (A)		Lift-point radius (B)										At max. reach				
		3.0 m (9.8 ft)		4.5 m (14.8 ft)		6.0 m (19.7 ft)		7.5 m (24.6 ft)		9.0 m (29.5 ft)		Capacity		Reach		
																m (ft)
9.0 m (29.5 ft)	kg													*11820	*11820	6.19
	lb													*26060	*26060	(20.3)
7.5 m (24.6 ft)	kg							*11250	10350					*10890	10250	7.54
	lb							*24800	22820					*24010	22600	(24.7)
6.0 m (19.7 ft)	kg					*13340	*13340	*11880	10240					*10600	8420	8.41
	lb					*29410	*29410	*26190	22580					*23370	18560	(27.6)
4.5 m (14.8 ft)	kg			*19300	*19300	*14830	13940	*12520	9900					*10710	7450	8.94
	lb			*42550	*42550	*32690	30730	*27600	21830					*23610	16420	(29.3)
3.0 m (9.8 ft)	kg			*22770	19820	*16450	13110	*13290	9480	*11400	7190			*11180	6950	9.20
	lb			*50200	43700	*36270	28900	*29300	20900	*25130	15850			*24650	15320	(30.2)
1.5 m (4.9 ft)	kg			*19910	18720	*17560	12450	*13870	9110	*11500	7020			*11210	6800	9.20
	lb			*43890	41270	*38710	27450	*30580	20080	*25350	15480			*24710	14990	(30.2)
0.0 m (0.0 ft)	kg			*23720	18390	*17760	12080	*13950	8870					*11220	6970	8.96
	lb			*52290	40540	*39150	26630	*30750	19550					*24740	15370	(29.4)
-1.5 m (-4.9 ft)	kg	*16270	*16270	*21890	18420	*16900	11980	*13220	8800					*11120	7550	8.44
	lb	*35870	*35870	*48260	40610	*37260	26410	*29150	19400					*24520	16640	(27.7)
-3.0 m (-9.8 ft)	kg	*22850	*22850	*18760	18700	*14740	12120	*10960	8970					*10700	8850	7.58
	lb	*50380	*50380	*41360	41230	*32500	26720	*24160	19780					*23590	19510	(24.9)
-4.5 m (-14.8 ft)	kg			*13560	*13560	*10150	*10150							*9330	*9330	6.27
	lb			*29890	*29890	*22380	*22380							*20570	*20570	(20.6)

Note 1. Lifting capacity are based on ISO 10567.

- Lifting capacity of the HX series does not exceed 75% of tipping load with the machine on firm, level ground or 87% of full hydraulic capacity.
- The Lift-point is bucket pivot mounting pin on the arm (without bucket mass).
- *Indicates load limited by hydraulic capacity.

※ Lifting capacities are based upon a standard machine conditions.

Lifting capacities will vary with different work tools, ground conditions and attachments.

The difference between the weight of a work tool attachment must be subtracted.

Consult with your local Hyundai dealer regarding the lifting capacities for specific work tools and attachments.









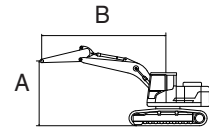



▲ Failure to comply to the rated load can cause serious injury, death, or property damage. Make adjustments to the rated load as necessary for non-standard configurations.

Model	Type	Boom	Arm	Counterweight	Shoe	Wheel	Dozer		Outrigger	
		Length [mm]	Length [mm]	weight [kg]	width [mm]	width [mm]	Front	Rear	Front	Rear
HX500LT3	MONO BOOM	7060	2550	9200	600	-	-	-	-	-

·  : Rating over-front

·  : Rating over-side or 360 degree



Lift-point height (A)	Lift-point radius (B)										At max. reach			
	3.0 m (9.8 ft)		4.5 m (14.8 ft)		6.0 m (19.7 ft)		7.5 m (24.6 ft)		9.0 m (29.5 ft)		Capacity		Reach	
													m (ft)	
9.0 m (29.5 ft)	kg											*12380	*12380	6.60
	lb											*27290	*27290	(21.6)
7.5 m (24.6 ft)	kg						*11560	10350				*11490	9480	7.87
	lb						*25490	22820				*25330	20900	(25.8)
6.0 m (19.7 ft)	kg					*13640	*13640	*11840	10150			*11100	7900	8.71
	lb					*30070	*30070	*26100	22380			*24470	17420	(28.6)
4.5 m (14.8 ft)	kg					*15260	13570	*12560	9760	*11060	7350	*10910	7050	9.22
	lb					*33640	29920	*27690	21520	*24380	16200	*24050	15540	(30.3)
3.0 m (9.8 ft)	kg					*16820	12750	*13340	9340	*11320	7160	*10840	6610	9.47
	lb					*37080	28110	*29410	20590	*24960	15790	*23900	14570	(31.1)
1.5 m (4.9 ft)	kg					*17670	12180	*13860	8990	*11470	6980	*10810	6490	9.48
	lb					*38960	26850	*30560	19820	*25290	15390	*23830	14310	(31.1)
0.0 m (0.0 ft)	kg					*17570	11930	*13880	8790	*11210	6880	*10770	6650	9.24
	lb					*38740	26300	*30600	19380	*24710	15170	*23740	14660	(30.3)
-1.5 m (-4.9 ft)	kg			*20510	18440	*16560	11900	*13170	8750			*10610	7190	8.74
	lb			*45220	40650	*36510	26230	*29030	19290			*23390	15850	(28.7)
-3.0 m (-9.8 ft)	kg	*19190	*19190	*17720	*17720	*14510	12070	*11260	8900			*10150	8340	7.92
	lb	*42310	*42310	*39070	*39070	*31990	26610	*24820	19620			*22380	18390	(26.0)
-4.5 m (-14.8 ft)	kg			*13240	*13240	*10610	*10610					*8830	*8830	6.66
	lb			*29190	*29190	*23390	*23390					*19470	*19470	(21.9)

Note 1. Lifting capacity are based on ISO 10567.

2. Lifting capacity of the HX series does not exceed 75% of tipping load with the machine on firm, level ground or 87% of full hydraulic capacity.

3. The Lift-point is bucket pivot mounting pin on the arm (without bucket mass).

4. *Indicates load limited by hydraulic capacity.

※ Lifting capacities are based upon a standard machine conditions.

Lifting capacities will vary with different work tools, ground conditions and attachments.

The difference between the weight of a work tool attachment must be subtracted.

Consult with your local Hyundai dealer regarding the lifting capacities for specific work tools and attachments.









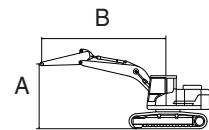



▲ Failure to comply to the rated load can cause serious injury, death, or property damage. Make adjustments to the rated load as necessary for non-standard configurations.

Model	Type	Boom	Arm	Counterweight	Shoe	Wheel	Dozer		Outrigger	
		Length [mm]	Length [mm]	weight [kg]	width [mm]	width [mm]	Front	Rear	Front	Rear
HX500LT3	MONO BOOM	7060	2900	9200	600	-	-	-	-	-

·  : Rating over-front

·  : Rating over-side or 360 degree



Lift-point height (A)	Lift-point radius (B)										At max. reach			
	3.0 m (9.8 ft)		4.5 m (14.8 ft)		6.0 m (19.7 ft)		7.5 m (24.6 ft)		9.0 m (29.5 ft)		Capacity		Reach	
													m (ft)	
9.0 m (29.5 ft)	kg											*11510	*11510	6.97
	lb											*25380	*25380	(22.9)
7.5 m (24.6 ft)	kg						*10980	10420				*10810	8910	8.19
	lb						*24210	22970				*23830	19640	(26.9)
6.0 m (19.7 ft)	kg				*13030	*13030	*11370	10180				*10500	7480	8.99
	lb				*28730	*28730	*25070	22440				*23150	16490	(29.5)
4.5 m (14.8 ft)	kg		*19780	*19780	*14660	13630	*12140	9760	*10690	7330	*10370	6690	9.49	
	lb		*43610	*43610	*32320	30050	*26760	21520	*23570	16160	*22860	14750	(31.1)	
3.0 m (9.8 ft)	kg				*16310	12750	*12980	9300	*11040	7100	*10340	6280	9.74	
	lb				*35960	28110	*28620	20500	*24340	15650	*22800	13850	(31.9)	
1.5 m (4.9 ft)	kg				*17350	12110	*13600	8910	*11280	6890	*10360	6140	9.74	
	lb				*38250	26700	*29980	19640	*24870	15190	*22840	13540	(32.0)	
0.0 m (0.0 ft)	kg		*14480	*14480	*17470	11780	*13750	8670	*11190	6760	*10380	6270	9.51	
	lb		*31920	*31920	*38510	25970	*30310	19110	*24670	14900	*22880	13820	(31.2)	
-1.5 m (-4.9 ft)	kg		*21210	18090	*16700	11700	*13230	8580	*10370	6760	*10320	6740	9.02	
	lb		*46760	39880	*36820	25790	*29170	18920	*22860	14900	*22750	14860	(29.6)	
-3.0 m (-9.8 ft)	kg	*21630	*21630	*18580	18360	*14930	11830	*11720	8690		*10040	7730	8.23	
	lb	*47690	*47690	*40960	40480	*32910	26080	*25840	19160		*22130	17040	(27.0)	
-4.5 m (-14.8 ft)	kg		*14450	*14450	*11610	*11610					*9130	*9130	7.04	
	lb		*31860	*31860	*25600	*25600					*20130	*20130	(23.1)	

Note 1. Lifting capacity are based on ISO 10567.

2. Lifting capacity of the HX series does not exceed 75% of tipping load with the machine on firm, level ground or 87% of full hydraulic capacity.

3. The Lift-point is bucket pivot mounting pin on the arm (without bucket mass).

4. *Indicates load limited by hydraulic capacity.

※ Lifting capacities are based upon a standard machine conditions.

Lifting capacities will vary with different work tools, ground conditions and attachments.

The difference between the weight of a work tool attachment must be subtracted.

Consult with your local Hyundai dealer regarding the lifting capacities for specific work tools and attachments.

▲ Failure to comply to the rated load can cause serious injury, death, or property damage. Make adjustments to the rated load as necessary for non-standard configurations.

Model	Type	Boom	Arm	Counterweight	Shoe	Wheel	Dozer		Outrigger	
		Length [mm]	Length [mm]	weight [kg]	width [mm]	width [mm]	Front	Rear	Front	Rear
HX500LT3	MONO BOOM	7060	3380	9200	600	-	-	-	-	-



: Rating over-front



: Rating over-side or 360 degree

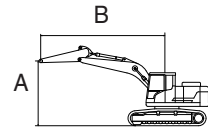

Lift-point height (A)		Lift-point radius (B)										At max. reach		
		3.0 m (9.8 ft)		4.5 m (14.8 ft)		6.0 m (19.7 ft)		7.5 m (24.6 ft)		9.0 m (29.5 ft)		Capacity		Reach
														m (ft)
9.0 m (29.5 ft)	kg							*9510	*9510			*9450	*9450	7.51
	lb							*20970	*20970			*20830	*20830	(24.6)
7.5 m (24.6 ft)	kg							*10350	*10350			*8950	8240	8.65
	lb							*22820	*22820			*19730	18170	(28.4)
6.0 m (19.7 ft)	kg							*10850	10330	*9990	7610	*8830	7020	9.41
	lb							*23920	22770	*22020	16780	*19470	15480	(30.9)
4.5 m (14.8 ft)	kg			*18480	*18480	*14010	13910	*11700	9900	*10330	7420	*8960	6310	9.89
	lb			*40740	*40740	*30890	30670	*25790	21830	*22770	16360	*19750	13910	(32.5)
3.0 m (9.8 ft)	kg					*15810	13010	*12650	9420	*10790	7160	*9350	5930	10.12
	lb					*34860	28680	*27890	20770	*23790	15790	*20610	13070	(33.2)
1.5 m (4.9 ft)	kg					*17100	12290	*13410	9000	*11150	6930	9870	5800	10.13
	lb					*37700	27090	*29560	19840	*24580	15280	21760	12790	(33.2)
0.0 m (0.0 ft)	kg			*17130	*17130	*17540	11870	*13740	8710	*11240	6750	*9970	5900	9.91
	lb			*37770	*37770	*38670	26170	*30290	19200	*24780	14880	*21980	13010	(32.5)
-1.5 m (-4.9 ft)	kg	*12220	*12220	*22260	18060	*17080	11720	*13470	8580	*10790	6690	*10000	6290	9.44
	lb	*26940	*26940	*49070	39820	*37650	25840	*29700	18920	*23790	14750	*22050	13870	(31.0)
-3.0 m (-9.8 ft)	kg	*20690	*20690	*19920	18260	*15660	11780	*12340	8610			*9900	7100	8.69
	lb	*45610	*45610	*43920	40260	*34520	25970	*27210	18980			*21830	15650	(28.5)
-4.5 m (-14.8 ft)	kg	*19790	*19790	*16250	*16250	*12920	12050	*9580	8890			*9390	8790	7.57
	lb	*43630	*43630	*35830	*35830	*28480	26570	*21120	19600			*20700	19380	(24.8)

Note 1. Lifting capacity are based on ISO 10567.

2. Lifting capacity of the HX series does not exceed 75% of tipping load with the machine on firm, level ground or 87% of full hydraulic capacity.

3. The Lift-point is bucket pivot mounting pin on the arm (without bucket mass).

4. *Indicates load limited by hydraulic capacity.

※ Lifting capacities are based upon a standard machine conditions.

Lifting capacities will vary with different work tools, ground conditions and attachments.









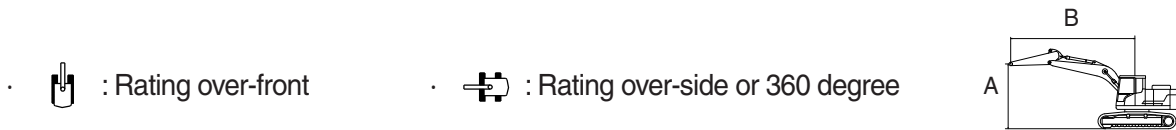







The difference between the weight of a work tool attachment must be subtracted.

Consult with your local Hyundai dealer regarding the lifting capacities for specific work tools and attachments.

▲ Failure to comply to the rated load can cause serious injury, death, or property damage. Make adjustments to the rated load as necessary for non-standard configurations.

Model	Type	Boom	Arm	Counterweight	Shoe	Wheel	Dozer		Outrigger	
		Length [mm]	Length [mm]	weight [kg]	width [mm]	width [mm]	Front	Rear	Front	Rear
HX500LT3	MONO BOOM	7060	4000	9200	600	-	-	-	-	-



Lift-point height (A)		Lift-point radius (B)														At max. reach			
		1.5 m (4.9 ft)		3.0 m (9.8 ft)		4.5 m (14.8 ft)		6.0 m (19.7 ft)		7.5 m (24.6 ft)		9.0 m (29.5 ft)		10.5 m (34.4 ft)		Capacity	Reach		
																		m (ft)	
9.0m 29.5ft	kg lb																*7340 *16180	*7340 *16180	8.24 (27.0)
7.5m 24.6ft	kg lb											*8410 *18540	7900 17420				*7010 *15450	*7010 *15450	9.29 (30.5)
6.0m 19.7ft	kg lb								*10200 *22490	*10200 *22490	*9450 *20830	7800 17200				*6930 *15280	6450 14220	10.01 (32.8)	
4.5m 14.8ft	kg lb						*13140 *28970	*13140 *28970	*11140 *24560	10130 22330	*9910 *21850	7580 16710				*7030 *15500	5860 12920	10.46 (34.3)	
3.0m 9.8ft	kg lb				*20800 *45860	20410 45000	*15100 *33290	13370 29480	*12210 *26920	9630 21230	*10480 *23100	7300 16090	*8720 *19220	5690 12540	*7320 *16140	5530 12190	10.68 (35.0)		
1.5m 4.9ft	kg lb				*20070 *44250	18940 41760	*16700 *36820	12570 27710	*13140 *28970	9170 20220	*10990 *24230	7030 15500	9410 20750	5560 12260	*7820 *17240	5410 11930	10.68 (35.0)		
0.0m 0.0ft	kg lb				*19100 *42110	18270 40280	*17520 *38620	12050 26570	*13700 *30200	8820 19440	*11260 *24820	6820 15040			*8600 *18960	5480 12080	10.47 (34.4)		
-1.5m -4.9ft	kg lb			*12230 *26960	*12230 *26960	*23290 *51350	18100 39900	*17450 *38470	11800 26010	*13710 *30230	8630 19030	*11110 *24490	6710 14790		*9540 *21030	5790 12760	10.03 (32.9)		
-3.0m -9.8ft	kg lb	*14130 *31150	*14130 *31150	*18540 *40870	*18540 *40870	*21430 *47250	18190 40100	*16470 *36310	11770 25950	*12980 *28620	8600 18960	*10210 *22510	6720 14820		*9570 *21100	6420 14150	9.33 (30.6)		
-4.5m -14.8ft	kg lb			*23840 *52560	*23840 *52560	*18340 *40430	*18340 *40430	*14340 *31610	11950 26350	*11120 *24520	8740 19270				*9360 *20640	7670 16910	8.30 (27.2)		
-6.0m -19.7ft	kg lb					*13350 *29430	*13350 *29430	*10290 *22690	*10290 *22690						*8450 *18630	*8450 *18630	6.78 (22.3)		

- Note
- Lifting capacity are based on ISO 10567.
 - Lifting capacity of the HX series does not exceed 75% of tipping load with the machine on firm, level ground or 87% of full hydraulic capacity.
 - The Lift-point is bucket pivot mounting pin on the arm (without bucket mass).
 - *Indicates load limited by hydraulic capacity.

※ Lifting capacities are based upon a standard machine conditions.

Lifting capacities will vary with different work tools, ground conditions and attachments.

The difference between the weight of a work tool attachment must be subtracted.

Consult with your local Hyundai dealer regarding the lifting capacities for specific work tools and attachments.

▲ Failure to comply to the rated load can cause serious injury, death, or property damage. Make adjustments to the rated load as necessary for non-standard configurations.

Model	Type	Boom	Arm	Counterweight	Shoe	Wheel	Dozer		Outrigger	
HX500LT3	MONO BOOM	Length [mm]	Length [mm]	weight [kg]	width [mm]	width [mm]	Front	Rear	Front	Rear
		9000	6000	10700	600	-	-	-	-	-



: Rating over-front



: Rating over-side or 360 degree

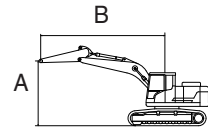

Lift-point height (A)		Lift-point radius (B)																		At max. reach			
		1.5 m (4.9 ft)		3.0 m (9.8 ft)		4.5 m (14.8 ft)		6.0 m (19.7 ft)		7.5 m (24.6 ft)		9.0 m (29.5 ft)		10.5 m (34.4 ft)		12.0 m (39.4 ft)		13.5 m (44.3 ft)		Capacity	Reach		
																						m (ft)	
10.5m 34.4ft	kg lb																				*4060 *8950	*4060 *8950	11.51 (37.7)
9.0m 29.5ft	kg lb															*4870 *10740	*4870 *10740				*3950 *8710	*3950 *8710	12.46 (40.9)
7.5m 24.6ft	kg lb													*5930 *13070	*5930 *13070	*5620 *12390	5150 11350				*3940 *8690	*3940 *8690	13.17 (43.2)
6.0m 19.7ft	kg lb													*6270 *13820	*6270 *13820	*5810 *12810	5000 11020	*4500 *9920	3900 8600	*3990 *8800	3770 8310	13.69 (44.9)	
4.5m 14.8ft	kg lb								*8790 *19380	*8790 *19380	*7540 *16620	*7540 *16620	*6680 *14730	6130 13510	*6060 *13360	4800 10580	*5520 *12170	3790 8360	*4110 *9060	3480 7670	14.02 (46.0)		
3.0m 9.8ft	kg lb			*17920 *39510	*17920 *39510	*12630 *27840	*12630 *27840	*9890 *21800	9810 21630	*8240 *18170	7430 16380	*7130 *15720	5780 12740	*6350 *14000	4580 10100	*5750 *12680	3650 8050	*4300 *9480	3290 7250	14.18 (46.5)			
1.5m 4.9ft	kg lb			*9790 *21580	*9790 *21580	*14170 *31240	12320 27160	*10870 *23960	9040 19930	*8880 *19580	6930 15280	*7550 *16640	5450 12020	*6610 *14570	4360 9610	*5890 *12990	3510 7740	*4580 *10100	3190 7030	14.19 (46.5)			
0.0m 0.0ft	kg lb			*9020 *19890	*9020 *19890	*15100 *33290	11450 25240	*11570 *25510	8440 18610	*9370 *20660	6520 14370	*7880 *17370	5170 11400	*6810 *15010	4170 9190	*5960 *13140	3400 7500	*4970 *10960	3170 6990	14.03 (46.0)			
-1.5m -4.9ft	kg lb	*4710 *10380	*4710 *10380	*6130 *13510	*6130 *13510	*10400 *22930	*10400 *22930	*15390 *33930	10970 24180	*11920 *26280	8030 17700	*9650 *21270	6210 13690	*8060 *17770	4950 10910	*6890 *15190	4020 8860	*5910 *13030	3310 7300	*5510 *12150	3230 7120	13.70 (45.0)	
-3.0m -9.8ft	kg lb	*7100 *15650	*7100 *15650	*8690 *19160	*8690 *19160	*12720 *28040	*12720 *28040	*15140 *33380	10770 23740	*11890 *26210	7820 17240	*9660 *21300	6030 13290	*8040 *17730	4810 10600	*6790 *14970	3930 8660			*5880 *12960	3400 7500	13.20 (43.3)	
-4.5m -14.8ft	kg lb	*9580 *21120	*9580 *21120	*11500 *25350	*11500 *25350	*15760 *34740	*15760 *34740	*14400 *31750	10760 23720	*11470 *25290	7750 17090	*9360 *20640	5960 13140	*7750 *17090	4770 10520	*6400 *14110	3930 8660			*5950 *13120	3710 8180	12.50 (41.0)	
-6.0m -19.7ft	kg lb	*12310 *27140	*12310 *27140	*14730 *32470	*14730 *32470	*16720 *36860	*16720 *36860	*13140 *28970	10920 24070	*10590 *23350	7830 17260	*8650 *19070	6010 13250	*7060 *15560	4830 10650					*5980 *13180	4240 9350	11.55 (37.9)	
-7.5m -24.6ft	kg lb			*18050 *39790	*18050 *39790	*13990 *30840	*13990 *30840	*11240 *24780	11230 24760	*9120 *20110	8040 17730	*7360 *16230	6190 13650							*5870 *12940	5160 11380	10.31 (33.8)	
-9.0m -29.5ft	kg lb					*10190 *22470	*10190 *22470	*8390 *18500	*8390 *18500	*6720 *14820	*6720 *14820									*5410 *11930	*5410 *11930	8.62 (28.3)	

Note 1. Lifting capacity are based on ISO 10567.

2. Lifting capacity of the HX series does not exceed 75% of tipping load with the machine on firm, level ground or 87% of full hydraulic capacity.

3. The Lift-point is bucket pivot mounting pin on the arm (without bucket mass).

4. *Indicates load limited by hydraulic capacity.

※ Lifting capacities are based upon a standard machine conditions.

Lifting capacities will vary with different work tools, ground conditions and attachments.

The difference between the weight of a work tool attachment must be subtracted.

Consult with your local Hyundai dealer regarding the lifting capacities for specific work tools and attachments.

▲ Failure to comply to the rated load can cause serious injury, death, or property damage. Make adjustments to the rated load as necessary for non-standard configurations.









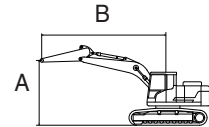

2) HX520LT3

Model	Type	Boom	Arm	Counterweight	Shoe	Wheel	Dozer		Outrigger	
		Length [mm]	Length [mm]	weight [kg]	width [mm]	width [mm]	Front	Rear	Front	Rear
HX520LT3	MONO BOOM	6550	2550	10200	600	-	-	-	-	-

·  : Rating over-front

·  : Rating over-side or 360 degree



Lift-point height (A)	Lift-point radius (B)								At max. reach			
	3.0 m (9.8 ft)		4.5 m (14.8 ft)		6.0 m (19.7 ft)		7.5 m (24.6 ft)		Capacity		Reach	
											m (ft)	
9.0 m (29.5 ft)	kg									*13740	*13740	5.92
	lb									*30290	*30290	(19.4)
7.5 m (24.6 ft)	kg				*13220	*13220				*12550	12490	7.29
	lb				*29150	*29150				*27670	27540	(23.9)
6.0 m (19.7 ft)	kg				*14060	*14060	*12430	11850	*12050	10280	8.17	
	lb				*31000	*31000	*27400	26120	*26570	22660	(26.8)	
4.5 m (14.8 ft)	kg		*20650	*20650	*15550	*15550	*13010	11530	*11820	9140	8.70	
	lb		*45530	*45530	*34280	*34280	*28680	25420	*26060	20150	(28.5)	
3.0 m (9.8 ft)	kg				*17050	15340	*13700	11140	*11730	8600	8.94	
	lb				*37590	33820	*30200	24560	*25860	18960	(29.3)	
1.5 m (4.9 ft)	kg				*17930	14760	*14130	10820	*11690	8480	8.93	
	lb				*39530	32540	*31150	23850	*25770	18700	(29.3)	
0.0 m (0.0 ft)	kg		*21780	*21780	*17810	14470	*14000	10630	*11610	8770	8.66	
	lb		*48020	*48020	*39260	31900	*30860	23440	*25600	19330	(28.4)	
-1.5 m (-4.9 ft)	kg	*16090	*16090	*21090	*21090	*16590	14440	*12900	10620	*11370	9630	8.10
	lb	*35470	*35470	*46500	*46500	*36570	31830	*28440	23410	*25070	21230	(26.6)
-3.0 m (-9.8 ft)	kg	*20140	*20140	*17510	*17510	*13900	*13900			*10640	*10640	7.18
	lb	*44400	*44400	*38600	*38600	*30640	*30640			*23460	*23460	(23.6)

Note 1. Lifting capacity are based on ISO 10567.

2. Lifting capacity of the HX series does not exceed 75% of tipping load with the machine on firm, level ground or 87% of full hydraulic capacity.

3. The Lift-point is bucket pivot mounting pin on the arm (without bucket mass).

4. *Indicates load limited by hydraulic capacity.

※ Lifting capacities are based upon a standard machine conditions.

Lifting capacities will vary with different work tools, ground conditions and attachments.

The difference between the weight of a work tool attachment must be subtracted.

Consult with your local Hyundai dealer regarding the lifting capacities for specific work tools and attachments.









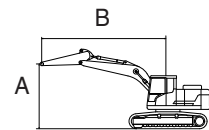





▲ Failure to comply to the rated load can cause serious injury, death, or property damage. Make adjustments to the rated load as necessary for non-standard configurations.

Model	Type	Boom	Arm	Counterweight	Shoe	Wheel	Dozer		Outrigger	
		Length [mm]	Length [mm]	weight [kg]	width [mm]	width [mm]	Front	Rear	Front	Rear
HX520LT3	MONO BOOM	6550	2900	10200	600	-	-	-	-	-

•  : Rating over-front

•  : Rating over-side or 360 degree



Lift-point height (A)		Lift-point radius (B)										At max. reach				
		3.0 m (9.8 ft)		4.5 m (14.8 ft)		6.0 m (19.7 ft)		7.5 m (24.6 ft)		9.0 m (29.5 ft)		Capacity		Reach		
																m (ft)
9.0 m (29.5 ft)	kg													*11720	*11720	6.31
	lb													*25840	*25840	(20.7)
7.5 m (24.6 ft)	kg							*11790	*11790					*10850	*10850	7.61
	lb							*25990	*25990					*23920	*23920	(25.0)
6.0 m (19.7 ft)	kg					*13430	*13430	*11920	11890					*10600	9740	8.45
	lb					*29610	*29610	*26280	26210					*23370	21470	(27.7)
4.5 m (14.8 ft)	kg			*19570	*19570	*14950	*14950	*12570	11530					*10730	8700	8.97
	lb			*43140	*43140	*32960	*32960	*27710	25420					*23660	19180	(29.4)
3.0 m (9.8 ft)	kg			*22960	*22960	*16550	15350	*13340	11110	*11410	8470			*11190	8180	9.21
	lb			*50620	*50620	*36490	33840	*29410	24490	*25150	18670			*24670	18030	(30.2)
1.5 m (4.9 ft)	kg			*19880	*19880	*17610	14700	*13890	10740	*11490	8300			*11210	8050	9.19
	lb			*43830	*43830	*38820	32410	*30620	23680	*25330	18300			*24710	17750	(30.2)
0.0 m (0.0 ft)	kg			*23620	22030	*17730	14340	*13920	10510					*11210	8300	8.93
	lb			*52070	48570	*39090	31610	*30690	23170					*24710	18300	(29.3)
-1.5 m (-4.9 ft)	kg	*17060	*17060	*21710	*21710	*16790	14250	*13120	10450					*11100	9030	8.39
	lb	*37610	*37610	*47860	*47860	*37020	31420	*28920	23040					*24470	19910	(27.5)
-3.0 m (-9.8 ft)	kg	*22460	*22460	*18470	*18470	*14520	14410	*10680	10650					*10650	10630	7.51
	lb	*49520	*49520	*40720	*40720	*32010	31770	*23550	23480					*23480	23440	(24.6)
-4.5 m (-14.8 ft)	kg			*13060	*13060	*9620	*9620							*9150	*9150	6.15
	lb			*28790	*28790	*21210	*21210							*20170	*20170	(20.2)

Note 1. Lifting capacity are based on ISO 10567.

2. Lifting capacity of the HX series does not exceed 75% of tipping load with the machine on firm, level ground or 87% of full hydraulic capacity.

3. The Lift-point is bucket pivot mounting pin on the arm (without bucket mass).

4. *Indicates load limited by hydraulic capacity.

※ Lifting capacities are based upon a standard machine conditions.

Lifting capacities will vary with different work tools, ground conditions and attachments.

The difference between the weight of a work tool attachment must be subtracted.

Consult with your local Hyundai dealer regarding the lifting capacities for specific work tools and attachments.









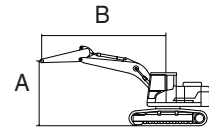





▲ Failure to comply to the rated load can cause serious injury, death, or property damage. Make adjustments to the rated load as necessary for non-standard configurations.

Model	Type	Boom	Arm	Counterweight	Shoe	Wheel	Dozer		Outrigger	
		Length [mm]	Length [mm]	weight [kg]	width [mm]	width [mm]	Front	Rear	Front	Rear
HX520LT3	MONO BOOM	7060	2550	10200	600	-	-	-	-	-

·  : Rating over-front

·  : Rating over-side or 360 degree



Lift-point height (A)		Lift-point radius (B)										At max. reach				
		3.0 m (9.8 ft)		4.5 m (14.8 ft)		6.0 m (19.7 ft)		7.5 m (24.6 ft)		9.0 m (29.5 ft)		Capacity		Reach		
																m (ft)
9.0 m (29.5 ft)	kg													*12280	*12280	6.71
	lb													*27070	*27070	(22.0)
7.5 m (24.6 ft)	kg							*11560	*11560					*11450	10870	7.94
	lb							*25490	*25490					*25240	23960	(26.1)
6.0 m (19.7 ft)	kg					*13750	*13750	*11890	11790					*11080	9170	8.75
	lb					*30310	*30310	*26210	25990					*24430	20220	(28.7)
4.5 m (14.8 ft)	kg					*15380	*15380	*12620	11390	*11070	8630			*10910	8250	9.25
	lb					*33910	*33910	*27820	25110	*24410	19030			*24050	18190	(30.3)
3.0 m (9.8 ft)	kg					*16910	14980	*13390	10960	*11340	8430			*10840	7800	9.48
	lb					*37280	33030	*29520	24160	*25000	18580			*23900	17200	(31.1)
1.5 m (4.9 ft)	kg					*17700	14430	*13880	10620	*11470	8260			*10810	7690	9.47
	lb					*39020	31810	*30600	23410	*25290	18210			*23830	16950	(31.1)
0.0 m (0.0 ft)	kg					*17530	14190	*13850	10420	*11160	8170			*10760	7930	9.21
	lb					*38650	31280	*30530	22970	*24600	18010			*23720	17480	(30.2)
-1.5 m (-4.9 ft)	kg			*20350	*20350	*16450	14180	*13080	10390					*10600	8600	8.69
	lb			*44860	*44860	*36270	31260	*28840	22910					*23370	18960	(28.5)
-3.0 m (-9.8 ft)	kg	*18970	*18970	*17470	*17470	*14320	*14320	*11040	10570					*10090	10010	7.84
	lb	*41820	*41820	*38510	*38510	*31570	*31570	*24340	23300					*22240	22070	(25.7)
-4.5 m (-14.8 ft)	kg			*12820	*12820	*10190	*10190							*8660	*8660	6.55
	lb			*28260	*28260	*22470	*22470							*19090	*19090	(21.5)

Note 1. Lifting capacity are based on ISO 10567.

2. Lifting capacity of the HX series does not exceed 75% of tipping load with the machine on firm, level ground or 87% of full hydraulic capacity.

3. The Lift-point is bucket pivot mounting pin on the arm (without bucket mass).

4. *Indicates load limited by hydraulic capacity.

※ Lifting capacities are based upon a standard machine conditions.

Lifting capacities will vary with different work tools, ground conditions and attachments.

The difference between the weight of a work tool attachment must be subtracted.

Consult with your local Hyundai dealer regarding the lifting capacities for specific work tools and attachments.









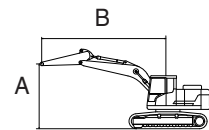





▲ Failure to comply to the rated load can cause serious injury, death, or property damage. Make adjustments to the rated load as necessary for non-standard configurations.

Model	Type	Boom	Arm	Counterweight	Shoe	Wheel	Dozer		Outrigger	
		Length [mm]	Length [mm]	weight [kg]	width [mm]	width [mm]	Front	Rear	Front	Rear
HX520LT3	MONO BOOM	7060	2900	10200	600	-	-	-	-	-

·  : Rating over-front

·  : Rating over-side or 360 degree



Lift-point height (A)		Lift-point radius (B)										At max. reach				
		3.0 m (9.8 ft)		4.5 m (14.8 ft)		6.0 m (19.7 ft)		7.5 m (24.6 ft)		9.0 m (29.5 ft)		Capacity		Reach		
																m (ft)
9.0 m (29.5 ft)	kg													*11430	*11430	7.08
	lb													*25200	*25200	(23.2)
7.5 m (24.6 ft)	kg							*10990	*10990					*10780	10230	8.26
	lb							*24230	*24230					*23770	22550	(27.1)
6.0 m (19.7 ft)	kg					*13130	*13130	*11410	*11410	*10500	8770	*10480	8700	9.04		
	lb					*28950	*28950	*25150	*25150	*23150	19330	*23100	19180	(29.7)		
4.5 m (14.8 ft)	kg			*20070	*20070	*14790	*14790	*12200	11390	*10710	8610	*10370	7850	9.52		
	lb			*44250	*44250	*32610	*32610	*26900	25110	*23610	18980	*22860	17310	(31.2)		
3.0 m (9.8 ft)	kg					*16410	14990	*13040	10920	*11060	8370	*10340	7420	9.74		
	lb					*36180	33050	*28750	24070	*24380	18450	*22800	16360	(32.0)		
1.5 m (4.9 ft)	kg					*17390	14350	*13630	10540	*11290	8160	*10370	7300	9.73		
	lb					*38340	31640	*30050	23240	*24890	17990	*22860	16090	(31.9)		
0.0 m (0.0 ft)	kg			*15060	*15060	*17450	14030	*13740	10300	*11160	8040	*10380	7500	9.48		
	lb			*33200	*33200	*38470	30930	*30290	22710	*24600	17730	*22880	16530	(31.1)		
-1.5 m (-4.9 ft)	kg			*21050	*21050	*16610	13970	*13170	10230			*10310	8080	8.98		
	lb			*46410	*46410	*36620	30800	*29030	22550			*22730	17810	(29.5)		
-3.0 m (-9.8 ft)	kg	*21360	*21360	*18340	*18340	*14760	14120	*11550	10350			*10000	9300	8.16		
	lb	*47090	*47090	*40430	*40430	*32540	31130	*25460	22820			*22050	20500	(26.8)		
-4.5 m (-14.8 ft)	kg			*14070	*14070	*11280	*11280					*9020	*9020	6.93		
	lb			*31020	*31020	*24870	*24870					*19890	*19890	(22.7)		

Note 1. Lifting capacity are based on ISO 10567.

- Lifting capacity of the HX series does not exceed 75% of tipping load with the machine on firm, level ground or 87% of full hydraulic capacity.
- The Lift-point is bucket pivot mounting pin on the arm (without bucket mass).
- *Indicates load limited by hydraulic capacity.

※ Lifting capacities are based upon a standard machine conditions.

Lifting capacities will vary with different work tools, ground conditions and attachments.

The difference between the weight of a work tool attachment must be subtracted.

Consult with your local Hyundai dealer regarding the lifting capacities for specific work tools and attachments.









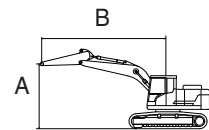





▲ Failure to comply to the rated load can cause serious injury, death, or property damage. Make adjustments to the rated load as necessary for non-standard configurations.

Model	Type	Boom	Arm	Counterweight	Shoe	Wheel	Dozer		Outrigger	
		Length [mm]	Length [mm]	weight [kg]	width [mm]	width [mm]	Front	Rear	Front	Rear
HX520LT3	MONO BOOM	7060	3380	10200	600	-	-	-	-	-

·  : Rating over-front

·  : Rating over-side or 360 degree



Lift-point height (A)		Lift-point radius (B)										At max. reach				
		3.0 m (9.8 ft)		4.5 m (14.8 ft)		6.0 m (19.7 ft)		7.5 m (24.6 ft)		9.0 m (29.5 ft)		Capacity		Reach		
																m (ft)
9.0 m (29.5 ft)	kg							*10020	*10020					*9400	*9400	7.61
	lb							*22090	*22090					*20720	*20720	(25.0)
7.5 m (24.6 ft)	kg							*10370	*10370					*8930	*8930	8.71
	lb							*22860	*22860					*19690	*19690	(28.6)
6.0 m (19.7 ft)	kg							*10900	*10900	*10010	8900			*8830	8170	9.46
	lb							*24030	*24030	*22070	19620			*19470	18010	(31.0)
4.5 m (14.8 ft)	kg			*18770	*18770	*14140	*14140	*11770	11530	*10360	8690			*8980	7420	9.92
	lb			*41380	*41380	*31170	*31170	*25950	25420	*22840	19160			*19800	16360	(32.5)
3.0 m (9.8 ft)	kg					*15920	15240	*12710	11050	*10820	8440			*9390	7020	10.13
	lb					*35100	33600	*28020	24360	*23850	18610			*20700	15480	(33.2)
1.5 m (4.9 ft)	kg					*17160	14530	*13450	10620	*11170	8200			*9890	6910	10.12
	lb					*37830	32030	*29650	23410	*24630	18080			*21800	15230	(33.2)
0.0 m (0.0 ft)	kg			*17510	*17510	*17540	14120	*13750	10340	*11230	8030			*9970	7060	9.88
	lb			*38600	*38600	*38670	31130	*30310	22800	*24760	17700			*21980	15560	(32.4)
-1.5 m (-4.9 ft)	kg	*12800	*12800	*22130	21700	*17010	13980	*13420	10210	*10720	7980			*10000	7550	9.40
	lb	*28220	*28220	*48790	47840	*37500	30820	*29590	22510	*23630	17590			*22050	16640	(30.8)
-3.0 m (-9.8 ft)	kg	*21350	*21350	*19710	*19710	*15510	14060	*12210	10260					*9880	8550	8.62
	lb	*47070	*47070	*43450	*43450	*34190	31000	*26920	22620					*21780	18850	(28.3)
-4.5 m (-14.8 ft)	kg	*19320	*19320	*15920	*15920	*12650	*12650							*9320	*9320	7.47
	lb	*42590	*42590	*35100	*35100	*27890	*27890							*20550	*20550	(24.5)

Note 1. Lifting capacity are based on ISO 10567.

2. Lifting capacity of the HX series does not exceed 75% of tipping load with the machine on firm, level ground or 87% of full hydraulic capacity.

3. The Lift-point is bucket pivot mounting pin on the arm (without bucket mass).

4. *Indicates load limited by hydraulic capacity.

※ Lifting capacities are based upon a standard machine conditions.

Lifting capacities will vary with different work tools, ground conditions and attachments.

The difference between the weight of a work tool attachment must be subtracted.

Consult with your local Hyundai dealer regarding the lifting capacities for specific work tools and attachments.

▲ Failure to comply to the rated load can cause serious injury, death, or property damage. Make adjustments to the rated load as necessary for non-standard configurations.

Model	Type	Boom	Arm	Counterweight	Shoe	Wheel	Dozer		Outrigger	
		Length [mm]	Length [mm]	weight [kg]	width [mm]	width [mm]	Front	Rear	Front	Rear
HX520LT3	MONO BOOM	7060	4000	10200	600	-	-	-	-	-



: Rating over-front



: Rating over-side or 360 degree

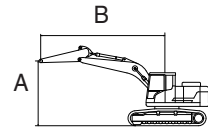

Lift-point height (A)	Lift-point radius (B)												At max. reach			
	3.0 m (9.8 ft)		4.5 m (14.8 ft)		6.0 m (19.7 ft)		7.5 m (24.6 ft)		9.0 m (29.5 ft)		10.5 m (34.4 ft)		Capacity		Reach	
															m (ft)	
9.0 m (29.5 ft)	kg													*7310	*7310	8.33
	lb													*16120	*16120	(27.3)
7.5 m (24.6 ft)	kg							*8630	*8630					*6990	*6990	9.35
	lb							*19030	*19030					*15410	*15410	(30.7)
6.0 m (19.7 ft)	kg						*10230	*10230	*9440	9080				*6930	*6930	10.05
	lb						*22550	*22550	*20810	20020				*15280	*15280	(33.0)
4.5 m (14.8 ft)	kg				*13240	*13240	*11180	*11180	*9910	8840				*7050	6870	10.48
	lb				*29190	*29190	*24650	*24650	*21850	19490				*15540	15150	(34.4)
3.0 m (9.8 ft)	kg		*20970	*20970	*15180	*15180	*12230	11230	*10470	8550	*8810	6710	*7350	6520	10.69	
	lb		*46230	*46230	*33470	*33470	*26960	24760	*23080	18850	*19420	14790	*16200	14370	(35.1)	
1.5 m (4.9 ft)	kg		*19680	*19680	*16710	14760	*13130	10760	*10960	8270	*9440	6570	*7860	6410	10.67	
	lb		*43390	*43390	*36840	32540	*28950	23720	*24160	18230	*20810	14480	*17330	14130	(35.0)	
0.0 m (0.0 ft)	kg		*19280	*19280	*17450	14230	*13650	10410	*11200	8060			*8670	6520	10.45	
	lb		*42510	*42510	*38470	31370	*30090	22950	*24690	17770			*19110	14370	(34.3)	
-1.5 m (-4.9 ft)	kg	*12650	*12650	*23060	21630	*17320	13990	*13600	10210	*11010	7950			*9490	6900	9.99
	lb	*27890	*27890	*50840	47690	*38180	30840	*29980	22510	*24270	17530			*20920	15210	(32.8)
-3.0 m (-9.8 ft)	kg	*19040	*19040	*21120	*21120	*16250	13970	*12810	10190	*10030	7970			*9500	7680	9.27
	lb	*41980	*41980	*46560	*46560	*35830	30800	*28240	22470	*22110	17570			*20940	16930	(30.4)
-4.5 m (-14.8 ft)	kg	*23210	*23210	*17930	*17930	*14030	*14030	*10830	10360					*9250	9210	8.21
	lb	*51170	*51170	*39530	*39530	*30930	*30930	*23880	22840					*20390	20300	(26.9)
-6.0 m (-19.7 ft)	kg			*12760	*12760	*9770	*9770							*8240	*8240	6.65
	lb			*28130	*28130	*21540	*21540							*18170	*18170	(21.8)

Note 1. Lifting capacity are based on ISO 10567.

2. Lifting capacity of the HX series does not exceed 75% of tipping load with the machine on firm, level ground or 87% of full hydraulic capacity.

3. The Lift-point is bucket pivot mounting pin on the arm (without bucket mass).

4. *Indicates load limited by hydraulic capacity.

※ Lifting capacities are based upon a standard machine conditions.

Lifting capacities will vary with different work tools, ground conditions and attachments.

The difference between the weight of a work tool attachment must be subtracted.

Consult with your local Hyundai dealer regarding the lifting capacities for specific work tools and attachments.

▲ Failure to comply to the rated load can cause serious injury, death, or property damage. Make adjustments to the rated load as necessary for non-standard configurations.

Model	Type	Boom	Arm	Counterweight	Shoe	Wheel	Dozer		Outrigger	
HX520LT3	MONO BOOM	Length [mm]	Length [mm]	weight [kg]	width [mm]	width [mm]	Front	Rear	Front	Rear
		9000	6000	11700	600	-	-	-	-	-



: Rating over-front



: Rating over-side or 360 degree

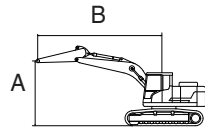

Lift-point height (A)		Lift-point radius (B)																		At max. reach			
		1.5 m (4.9 ft)		3.0 m (9.8 ft)		4.5 m (14.8 ft)		6.0 m (19.7 ft)		7.5 m (24.6 ft)		9.0 m (29.5 ft)		10.5 m (34.4 ft)		12.0 m (39.4 ft)		13.5 m (44.3 ft)		Capacity	Reach		
																						m (ft)	
10.5m 34.4ft	kg lb																				*4050 *8930	*4050 *8930	11.58 (38.0)
9.0m 29.5ft	kg lb															*4970 *10960	*4970 *10960				*3950 *8710	*3950 *8710	12.52 (41.1)
7.5m 24.6ft	kg lb													*5950 *13120	*5950 *13120	*5630 *12410	*5630 *12410				*3940 *8690	*3940 *8690	13.22 (43.4)
6.0m 19.7ft	kg lb													*6290 *13870	*6290 *13870	*5830 *12850	*5830 *12850	*4580 *10100	*4580 *10100		*3990 *8800	*3990 *8800	13.71 (45.0)
4.5m 14.8ft	kg lb								*8870 *19550	*8870 *19550	*7590 *16730	*7590 *16730	*6720 *14820	*6720 *14820	*6080 *13400	5700 12570	*5580 *12300	4570 10080			*4120 *9080	*4120 *9080	14.03 (46.0)
3.0m 9.8ft	kg lb					*18150 *40010	*18150 *40010	*12750 *28110	*12750 *28110	*9970 *21980	*9970 *21980	*8290 *18280	*8290 *18280	*7160 *15790	6840 15080	*6370 *14040	5480 12080	*5760 *12700	4430 9770		*4320 *9520	4030 8880	14.19 (46.5)
1.5m 4.9ft	kg lb					*9590 *21140	*9590 *21140	*14260 *31440	*14260 *31440	*10930 *24100	10670 23520	*8920 *19670	8210 18100	*7580 *16710	6510 14350	*6620 *14590	5260 11600	*5900 *13010	4300 9480		*4610 *10160	3930 8660	14.18 (46.5)
0.0m 0.0ft	kg lb					*9080 *20020	*9080 *20020	*15140 *33380	13710 30230	*11610 *25600	10080 22220	*9400 *20720	7800 17200	*7900 *17420	6230 13730	*6820 *15040	5070 11180	*5960 *13140	4180 9220		*5000 *11020	3920 8640	14.01 (46.0)
-1.5m -4.9ft	kg lb	*4880 *10760	*4880 *10760	*6310 *13910	*6310 *13910	*10540 *23240	*10540 *23240	*15390 *33930	13250 29210	*11930 *26300	9680 21340	*9660 *21300	7500 16530	*8070 *17790	6010 13250	*6890 *15190	4920 10850	*5900 *13010	4100 9040		*5560 *12260	4020 8860	13.67 (44.9)
-3.0m -9.8ft	kg lb	*7270 *16030	*7270 *16030	*8890 *19600	*8890 *19600	*12910 *28460	*12910 *28460	*15110 *33310	13060 28790	*11880 *26190	9470 20880	*9650 *21270	7320 16140	*8030 *17700	5880 12960	*6770 *14930	4840 10670				*5880 *12960	4230 9330	13.16 (43.2)
-4.5m -14.8ft	kg lb	*9770 *21540	*9770 *21540	*11720 *25840	*11720 *25840	*16010 *35300	*16010 *35300	*14330 *31590	13060 28790	*11420 *25180	9420 20770	*9320 *20550	7260 16010	*7710 *17000	5840 12870	*6360 *14020	4840 10670				*5960 *13140	4610 10160	12.44 (40.8)
-6.0m -19.7ft	kg lb	*12520 *27600	*12520 *27600	*14980 *33030	*14980 *33030	*16550 *36490	*16550 *36490	*13030 *28730	*13030 *28730	*10510 *23170	9500 20940	*8580 *18920	7320 16140	*6980 *15390	5910 13030						*5970 *13160	5250 11570	11.48 (37.6)
-7.5m -24.6ft	kg lb			*17690 *39000	*17690 *39000	*13760 *30340	*13760 *30340	*11070 *24410	*11070 *24410	*8990 *19820	*8990 *19820	*7230 *15940	*7230 *15940								*5850 *12900	*5850 *12900	10.20 (33.5)
-9.0m -29.5ft	kg lb					*9860 *21740	*9860 *21740	*8140 *17950	*8140 *17950	*6490 *14310	*6490 *14310										*5350 *11790	*5350 *11790	8.48 (27.8)

Note 1. Lifting capacity are based on ISO 10567.

2. Lifting capacity of the HX series does not exceed 75% of tipping load with the machine on firm, level ground or 87% of full hydraulic capacity.

3. The Lift-point is bucket pivot mounting pin on the arm (without bucket mass).

4. *Indicates load limited by hydraulic capacity.

※ Lifting capacities are based upon a standard machine conditions.

Lifting capacities will vary with different work tools, ground conditions and attachments.

The difference between the weight of a work tool attachment must be subtracted.

Consult with your local Hyundai dealer regarding the lifting capacities for specific work tools and attachments.

▲ Failure to comply to the rated load can cause serious injury, death, or property damage. Make adjustments to the rated load as necessary for non-standard configurations.

6. BUCKET SELECTION GUIDE

1) HX500LT3

(1) 9200 kg counterweight



General bucket



Heavy duty
(with side cutter)



Rock heavy duty

Type	Capacity		Width	Weight	Tooth	MONO					
	SAE Heaped	CECE heaped	Without side cutter			Recommendation					
						6.55 m (21' 6") Boom		7.06 m (23' 2") Boom			
	m ³ (yd ³)	m ³ (yd ³)	mm (in)			kg (lb)	EA	2.55 m (8' 4") Arm	2.90 m (9' 6") Arm	2.55 m (8' 4") Arm	2.90 m (9' 6") Arm
General bucket	1.38 (1.80)	1.24 (1.62)	1130 (44.5)	1640 (3620)	4	●	●	●	●	●	●
	2.20 (2.88)	1.93 (2.52)	1600 (63.0)	2020 (4450)	5	●	●	●	◐	◐	■
	3.00 (3.92)	2.64 (3.45)	1905 (75.0)	2425 (5350)	6	■	■	▲	▲	▲	X
Heavy duty	2.20 (2.88)	1.93 (2.52)	1600 (63.0)	2325 (5130)	5	●	●	◐	◐	■	■
	2.79 (3.65)	2.46 (3.22)	1795 (70.7)	2615 (5770)	5	■	■	■	▲	▲	X
	3.20 (4.19)	2.82 (3.69)	2015 (79.3)	2860 (6310)	6	■	▲	▲	▲	X	X
Rock heavy duty	2.20 (2.88)	2.11 (2.76)	1600 (63.0)	2605 (5740)	5	●	●	◐	◐	■	-
	2.43 (3.18)	0.76 (0.99)	1745 (68.7)	2730 (6020)	5	◐	◐	■	■	▲	-
	2.79 (3.65)	2.46 (3.22)	1795 (70.7)	2970 (6550)	5	■	■	▲	▲	▲	-
	3.20 (4.19)	2.82 (3.69)	2015 (79.3)	3235 (7130)	6	▲	▲	▲	X	X	-

●	Applicable for materials with density of 2100 kg/m ³ (3500 lb/yd ³) or less
◐	Applicable for materials with density of 1800 kg/m ³ (3000 lb/yd ³) or less
■	Applicable for materials with density of 1500 kg/m ³ (2500 lb/yd ³) or less
▲	Applicable for materials with density of 1200 kg/m ³ (2000 lb/yd ³) or less
X	Not recommended
-	Not available

※ These recommendations are for general conditions and average use.

Work tools and ground conditions have effects on machine performance.

Select an optimum combination according to the working conditions and the type of work that is being done.

Consult with your local Hyundai dealer for information on selecting the correct boom–arm–bucket combination.

(2) 9700 kg counterweight



General bucket



Heavy duty
(with side cutter)



Rock heavy duty

Type	Capacity		Width	Weight	Tooth	MONO					
	SAE Heaped	CECE heaped	Without side cutter			Recommendation					
				6.55 m (21' 6") Boom		7.06 m (23' 2") Boom					
	m ³ (yd ³)	m ³ (yd ³)	mm (in)	kg (lb)	EA	2.55 m (8' 4") Arm	2.90 m (9' 6") Arm	2.55 m (8' 4") Arm	2.90 m (9' 6") Arm	3.38 m (11' 1") Arm	4.00 m (13' 1") Arm
General bucket	1.38 (1.80)	1.24 (1.62)	1130 (44.5)	1640 (3620)	4	●	●	●	●	●	●
	2.20 (2.88)	1.93 (2.52)	1600 (63.0)	2020 (4450)	5	●	●	●	◐	◐	■
	3.00 (3.92)	2.64 (3.45)	1905 (75.0)	2425 (5350)	6	■	■	■	▲	▲	X
Heavy duty	2.20 (2.88)	1.93 (2.52)	1600 (63.0)	2325 (5130)	5	●	●	●	◐	◐	■
	2.79 (3.65)	2.46 (3.22)	1795 (70.7)	2615 (5770)	5	◐	■	■	■	▲	▲
	3.20 (4.19)	2.82 (3.69)	2015 (79.3)	2860 (6310)	6	■	▲	▲	▲	X	X
Rock heavy duty	2.20 (2.88)	2.11 (2.76)	1600 (63.0)	2605 (5740)	5	●	●	◐	◐	■	-
	2.43 (3.18)	0.76 (0.99)	1745 (68.7)	2730 (6020)	5	●	◐	◐	■	■	-
	2.79 (3.65)	2.46 (3.22)	1795 (70.7)	2970 (6550)	5	■	■	■	▲	▲	-
	3.20 (4.19)	2.82 (3.69)	2015 (79.3)	3235 (7130)	6	■	▲	▲	X	X	-

- Applicable for materials with density of 2100 kg/m³ (3500 lb/yd³) or less
- ◐ Applicable for materials with density of 1800 kg/m³ (3000 lb/yd³) or less
- Applicable for materials with density of 1500 kg/m³ (2500 lb/yd³) or less
- ▲ Applicable for materials with density of 1200 kg/m³ (2000 lb/yd³) or less
- X Not recommended
- Not available

※ These recommendations are for general conditions and average use.

Work tools and ground conditions have effects on machine performance.

Select an optimum combination according to the working conditions and the type of work that is being done.

Consult with your local Hyundai dealer for information on selecting the correct boom–arm–bucket combination.

(3) 10200 kg counterweight



General bucket



Heavy duty
(with side cutter)



Rock heavy duty

Type	Capacity		Width	Weight	Tooth	MONO					
	SAE Heaped	CECE heaped	Without side cutter			Recommendation					
				6.55 m (21' 6") Boom		7.06 m (23' 2") Boom					
	m ³ (yd ³)	m ³ (yd ³)	mm (in)	kg (lb)	EA	2.55 m (8' 4") Arm	2.90 m (9' 6") Arm	2.55 m (8' 4") Arm	2.90 m (9' 6") Arm	3.38 m (11' 1") Arm	4.00 m (13' 1") Arm
General bucket	1.38 (1.80)	1.24 (1.62)	1130 (44.5)	1640 (3620)	4	●	●	●	●	●	●
	2.20 (2.88)	1.93 (2.52)	1600 (63.0)	2020 (4450)	5	●	●	●	●	◐	◐
	3.00 (3.92)	2.64 (3.45)	1905 (75.0)	2425 (5350)	6	◐	■	■	■	▲	▲
Heavy duty	2.20 (2.88)	1.93 (2.52)	1600 (63.0)	2325 (5130)	5	●	●	●	◐	◐	■
	2.79 (3.65)	2.46 (3.22)	1795 (70.7)	2615 (5770)	5	◐	◐	■	■	▲	▲
	3.20 (4.19)	2.82 (3.69)	2015 (79.3)	2860 (6310)	6	■	■	▲	▲	▲	X
Rock heavy duty	2.20 (2.88)	2.11 (2.76)	1600 (63.0)	2605 (5740)	5	●	●	●	◐	◐	-
	2.43 (3.18)	0.76 (0.99)	1745 (68.7)	2730 (6020)	5	●	◐	◐	■	■	-
	2.79 (3.65)	2.46 (3.22)	1795 (70.7)	2970 (6550)	5	◐	■	■	▲	▲	-
	3.20 (4.19)	2.82 (3.69)	2015 (79.3)	3235 (7130)	6	■	▲	▲	▲	X	-

- Applicable for materials with density of 2100 kg/m³ (3500 lb/yd³) or less
- ◐ Applicable for materials with density of 1800 kg/m³ (3000 lb/yd³) or less
- Applicable for materials with density of 1500 kg/m³ (2500 lb/yd³) or less
- ▲ Applicable for materials with density of 1200 kg/m³ (2000 lb/yd³) or less
- X Not recommended
- Not available

※ These recommendations are for general conditions and average use.

Work tools and ground conditions have effects on machine performance.

Select an optimum combination according to the working conditions and the type of work that is being done.

Consult with your local Hyundai dealer for information on selecting the correct boom–arm–bucket combination.

(4) 10700 kg counterweight



General bucket



Heavy duty
(with side cutter)



Rock heavy duty

Type	Capacity		Width	Weight	Tooth	MONO						
	SAE Heaped	CECE heaped	Without side cutter			Recommendation						
				6.55 m (21' 6") Boom		7.06 m (23' 2") Boom			9.00 m (29' 6") Boom			
				2.55 m (8' 4") Arm	2.90 m (9' 6") Arm	2.55 m (8' 4") Arm	2.90 m (9' 6") Arm	3.38 m (11' 1") Arm	4.00 m (13' 1") Arm	6.00 m (19' 8") Arm		
m ³ (yd ³)	m ³ (yd ³)	mm (in)	kg (lb)	EA								
General bucket	1.38 (1.80)	1.24 (1.62)	1130 (44.5)	1640 (3620)	4	●	●	●	●	●	●	▲
	2.20 (2.88)	1.93 (2.52)	1600 (63.0)	2020 (4450)	5	●	●	●	●	◐	◐	-
	3.00 (3.92)	2.64 (3.45)	1905 (75.0)	2425 (5350)	6	◐	■	■	■	▲	▲	-
Heavy duty	2.20 (2.88)	1.93 (2.52)	1600 (63.0)	2325 (5130)	5	●	●	●	●	◐	■	-
	2.79 (3.65)	2.46 (3.22)	1795 (70.7)	2615 (5770)	5	◐	◐	■	■	■	▲	-
	3.20 (4.19)	2.82 (3.69)	2015 (79.3)	2860 (6310)	6	■	■	▲	▲	▲	X	-
Rock heavy duty	2.20 (2.88)	2.11 (2.76)	1600 (63.0)	2605 (5740)	5	●	●	●	◐	◐	-	-
	2.43 (3.18)	0.76 (0.99)	1745 (68.7)	2730 (6020)	5	●	●	◐	◐	■	-	-
	2.79 (3.65)	2.46 (3.22)	1795 (70.7)	2970 (6550)	5	◐	◐	■	■	▲	-	-
	3.20 (4.19)	2.82 (3.69)	2015 (79.3)	3235 (7130)	6	■	■	▲	▲	▲	-	-

- Applicable for materials with density of 2100 kg/m³ (3500 lb/yd³) or less
- ◐ Applicable for materials with density of 1800 kg/m³ (3000 lb/yd³) or less
- Applicable for materials with density of 1500 kg/m³ (2500 lb/yd³) or less
- ▲ Applicable for materials with density of 1200 kg/m³ (2000 lb/yd³) or less
- X Not recommended
- Not available

※ These recommendations are for general conditions and average use.

Work tools and ground conditions have effects on machine performance.

Select an optimum combination according to the working conditions and the type of work that is being done.

Consult with your local Hyundai dealer for information on selecting the correct boom–arm–bucket combination.

2) HX520LT3

(1) 10200 kg counterweight



General bucket



Heavy duty
(with side cutter)



Rock heavy duty

Type	Capacity		Width	Weight	Tooth	MONO					
	SAE Heaped	CECE heaped	Without side cutter			Recommendation					
						6.55 m (21' 6") Boom		7.06 m (23' 2") Boom			
	m ³ (yd ³)	m ³ (yd ³)	mm (in)			kg (lb)	EA	2.55 m (8' 4") Arm	2.90 m (9' 6") Arm	2.55 m (8' 4") Arm	2.90 m (9' 6") Arm
General bucket	1.00 (1.31)	0.90 (1.18)	910 (37.0)	1424 (3140)	3	●	●	●	●	●	●
	1.38 (1.18)	1.24 (1.62)	1130 (44.5)	1640 (3620)	4	●	●	●	●	●	●
	2.20 (2.88)	1.93 (2.52)	1600 (63.0)	2020 (4450)	5	●	●	●	●	●	◐
	2.79 (3.65)	2.46 (3.22)	1795 (70.7)	2295 (5060)	5	●	●	◐	◐	■	■
	3.00 (3.92)	2.64 (3.45)	1905 (75.0)	2425 (5350)	6	●	◐	◐	■	■	▲
Heavy duty	2.43 (3.18)	2.11 (2.76)	1745 (68.7)	2445 (5390)	5	●	●	●	●	◐	■
	3.20 (4.19)	2.82 (3.69)	2015 (79.3)	2860 (6310)	6	◐	■	■	■	▲	▲
Rock heavy duty	2.20 (2.88)	1.93 (2.52)	1600 (63.0)	2605 (5740)	5	●	●	●	●	●	-
	2.43 (3.18)	2.11 (2.76)	1745 (68.7)	2730 (6020)	5	●	●	●	◐	◐	-
	2.79 (3.65)	2.46 (3.22)	1795 (70.7)	2970 (6550)	5	●	◐	◐	■	■	-
	3.00 (3.92)	2.64 (3.45)	1905 (75.0)	3115 (6870)	6	◐	◐	■	■	▲	-
	3.20 (4.19)	2.82 (3.69)	2015 (79.3)	3235 (7130)	6	◐	■	■	▲	▲	-
Rock heavy duty (special)	1.81 (2.37)	1.50 (1.96)	1325 (52.2)	2685 (5920)	4	●	●	●	●	●	-
	2.70 (3.53)	2.39 (3.13)	1760 (69.3)	2755 (6070)	5	●	●	◐	◐	■	-
	3.00 (3.92)	2.76 (3.61)	1955 (77.0)	3040 (6700)	6	◐	◐	■	■	▲	-

● Applicable for materials with density of 2100 kg/m³ (3500 lb/yd³) or less

◐ Applicable for materials with density of 1800 kg/m³ (3000 lb/yd³) or less

■ Applicable for materials with density of 1500 kg/m³ (2500 lb/yd³) or less

▲ Applicable for materials with density of 1200 kg/m³ (2000 lb/yd³) or less

X Not recommended

- Not available

※ These recommendations are for general conditions and average use.

Work tools and ground conditions have effects on machine performance.

Select an optimum combination according to the working conditions and the type of work that is being done.

Consult with your local Hyundai dealer for information on selecting the correct boom–arm–bucket combination.

(2) 10700 kg counterweight



General bucket



Heavy duty
(with side cutter)



Rock heavy duty

Type	Capacity		Width	Weight	Tooth	MONO					
	SAE Heaped	CECE heaped	Without side cutter			Recommendation	6.55 m (21' 6") Boom		7.06 m (23' 2") Boom		
				m ³ (yd ³)	m ³ (yd ³)		mm (in)	kg (lb)	EA	2.55 m (8' 4") Arm	2.90 m (9' 6") Arm
	General bucket	1.00 (1.31)	0.90 (1.18)	910 (37.0)	1424 (3140)	3	●	●	●	●	●
1.38 (1.18)		1.24 (1.62)	1130 (44.5)	1640 (3620)	4	●	●	●	●	●	●
2.20 (2.88)		1.93 (2.52)	1600 (63.0)	2020 (4450)	5	●	●	●	●	●	●
2.79 (3.65)		2.46 (3.22)	1795 (70.7)	2295 (5060)	5	●	●	◐	◐	◐	■
3.00 (3.92)		2.64 (3.45)	1905 (75.0)	2425 (5350)	6	●	◐	◐	■	■	▲
Heavy duty	2.43 (3.18)	2.11 (2.76)	1745 (68.7)	2445 (5390)	5	●	●	●	●	◐	◐
	3.20 (4.19)	2.82 (3.69)	2015 (79.3)	2860 (6310)	6	◐	◐	■	■	▲	▲
Rock heavy duty	2.20 (2.88)	1.93 (2.52)	1600 (63.0)	2605 (5740)	5	●	●	●	●	●	-
	2.43 (3.18)	2.11 (2.76)	1745 (68.7)	2730 (6020)	5	●	●	●	●	◐	-
	2.79 (3.65)	2.46 (3.22)	1795 (70.7)	2970 (6550)	5	●	◐	◐	◐	■	-
	3.00 (3.92)	2.64 (3.45)	1905 (75.0)	3115 (6870)	6	◐	◐	■	■	■	-
	3.20 (4.19)	2.82 (3.69)	2015 (79.3)	3235 (7130)	6	◐	■	■	■	▲	-
Rock heavy duty (special)	1.81 (2.37)	1.50 (1.96)	1325 (52.2)	2685 (5920)	4	●	●	●	●	●	-
	2.70 (3.53)	2.39 (3.13)	1760 (69.3)	2755 (6070)	5	●	●	◐	◐	■	-
	3.00 (3.92)	2.76 (3.61)	1955 (77.0)	3040 (6700)	6	◐	◐	■	■	■	-

- Applicable for materials with density of 2100 kg/m³ (3500 lb/yd³) or less
- ◐ Applicable for materials with density of 1800 kg/m³ (3000 lb/yd³) or less
- Applicable for materials with density of 1500 kg/m³ (2500 lb/yd³) or less
- ▲ Applicable for materials with density of 1200 kg/m³ (2000 lb/yd³) or less
- X Not recommended
- Not available

※ These recommendations are for general conditions and average use.

Work tools and ground conditions have effects on machine performance.

Select an optimum combination according to the working conditions and the type of work that is being done.

Consult with your local Hyundai dealer for information on selecting the correct boom–arm–bucket combination.

(3) 11700 kg counterweight



General bucket



Heavy duty
(with side cutter)



Rock heavy duty

Type	Capacity		Width	Weight	Tooth	MONO						
	SAE Heaped	CECE heaped	Without side cutter			Recommendation						
				m ³ (yd ³)	m ³ (yd ³)	mm (in)	kg (lb)	EA	6.55 m (21' 6") Boom		7.06 m (23' 2") Boom	
	2.55 m (8' 4") Arm	2.90 m (9' 6") Arm	2.55 m (8' 4") Arm						2.90 m (9' 6") Arm	3.38 m (11' 1") Arm	4.00 m (13' 1") Arm	6.00 m (19' 8") Arm
General bucket	1.00 (1.31)	0.90 (1.18)	910 (37.0)	1424 (3140)	3	●	●	●	●	●	●	●
	1.38 (1.18)	1.24 (1.62)	1130 (44.5)	1640 (3620)	4	●	●	●	●	●	●	◐
	2.20 (2.88)	1.93 (2.52)	1600 (63.0)	2020 (4450)	5	●	●	●	●	●	●	-
	2.79 (3.65)	2.46 (3.22)	1795 (70.7)	2295 (5060)	5	●	●	●	●	◐	■	-
	3.00 (3.92)	2.64 (3.45)	1905 (75.0)	2425 (5350)	6	●	●	◐	◐	■	■	-
Heavy duty	2.43 (3.18)	2.11 (2.76)	1745 (68.7)	2445 (5390)	5	●	●	●	●	●	◐	-
	3.20 (4.19)	2.82 (3.69)	2015 (79.3)	2860 (6310)	6	●	◐	◐	■	■	▲	-
Rock heavy duty	2.20 (2.88)	1.93 (2.52)	1600 (63.0)	2605 (5740)	5	●	●	●	●	●	X	-
	2.43 (3.18)	2.11 (2.76)	1745 (68.7)	2730 (6020)	5	●	●	●	●	●	X	-
	2.79 (3.65)	2.46 (3.22)	1795 (70.7)	2970 (6550)	5	●	●	◐	◐	◐	X	-
	3.00 (3.92)	2.64 (3.45)	1905 (75.0)	3115 (6870)	6	●	◐	◐	■	■	X	-
	3.20 (4.19)	2.82 (3.69)	2015 (79.3)	3235 (7130)	6	◐	◐	■	■	■	X	-
Rock heavy duty (special)	1.81 (2.37)	1.50 (1.96)	1325 (52.2)	2685 (5920)	4	●	●	●	●	●	X	-
	2.70 (3.53)	2.39 (3.13)	1760 (69.3)	2755 (6070)	5	●	●	●	◐	◐	X	-
	3.00 (3.92)	2.76 (3.61)	1955 (77.0)	3040 (6700)	6	●	◐	◐	◐	■	X	-

- Applicable for materials with density of 2100 kg/m³ (3500 lb/yd³) or less
- ◐ Applicable for materials with density of 1800 kg/m³ (3000 lb/yd³) or less
- Applicable for materials with density of 1500 kg/m³ (2500 lb/yd³) or less
- ▲ Applicable for materials with density of 1200 kg/m³ (2000 lb/yd³) or less
- X Not recommended
- Not available

※ These recommendations are for general conditions and average use.

Work tools and ground conditions have effects on machine performance.

Select an optimum combination according to the working conditions and the type of work that is being done.

Consult with your local Hyundai dealer for information on selecting the correct boom–arm–bucket combination.

7. UNDERCARRIAGE

1) TYPES OF SHOES

Model	Description	Unit		Triple grouser										Double grouser	
		width	mm	(in)	600	(24)	700	(28)	800	(32)	900	(36)	600 HD	(24)	600
HX500LT3	Operating weight	kg	(lb)	48860	107720	49580	109310	50110	110470	50620	111600	49250	108580	49100	108250
	Ground pressure	kgf/cm ²	(psi)	0.85	(12.1)	0.74	(10.5)	0.65	(9.3)	0.59	(8.3)	0.86	(12.2)	0.85	(12.1)
	Overall width	mm	(ft-in)	3340	(10' 11")	3440	(11' 3")	3540	(11' 7")	3640	(11' 11")	3340	(10' 11")	3340	(10' 11")
	Link quantity	EA		53		53		53		53		53		53	
HX520LT3	Operating weight	kg	(lb)	51390	113300	52120	114900	52650	116070	53160	117200	51780	114160	51630	113820
	Ground pressure	kgf/cm ²	(psi)	0.89	(12.7)	0.78	(11.0)	0.69	(9.7)	0.62	(8.8)	0.90	(12.8)	0.90	(12.7)
	Overall width	mm	(ft-in)	3540	(11' 7")	3640	(11' 11")	3740	(12' 3")	3840	(12' 7")	3540	(11' 7")	3540	(11' 7")
	Link quantity	EA		53		53		53		53		53		53	

2) SELECTION OF TRACK SHOE

Suitable track shoes should be selected according to operating conditions.

Method of selecting shoes

Confirm the category from the list of applications in **table 2**, then use **table 1** to select the shoe. Wide shoes (categories B and C) have limitations on applications. Before using wide shoes, check the precautions, then investigate and study the operating conditions to confirm if these shoes are suitable.

Select the narrowest shoe possible to meet the required flotation and ground pressure. Application of wider shoes than recommendations will cause unexpected problem such as bending of shoes, crack of link, breakage of pin, loosening of shoe bolts and the other various problems.

Table 1

Track shoe	Specification	Category
600 mm triple grouser	Standard	A
700 mm triple grouser	Option	B
800 mm triple grouser	Option	C
900 mm triple grouser	Option	C
600 mm double grouser	Option	A

Table 2

Category	Applications	Precautions
A	Rocky ground, river beds, normal soil	<ul style="list-style-type: none">· Travel at low speed on rough ground with large obstacles such as boulders or fallen trees or a wide range of general civil engineering work
B	Normal soil, soft ground	<ul style="list-style-type: none">· These shoes cannot be used on rough ground with large obstacles such as boulders or fallen trees· Travel at high speed only on flat ground· Travel slowly at low speed if it is impossible to avoid going over obstacles
C	Extremely soft ground (swampy ground)	<ul style="list-style-type: none">· Use the shoes only in the conditions that the machine sinks and it is impossible to use the shoes of category A or B· These shoes cannot be used on rough ground with large obstacles such as boulders or fallen trees· Travel at high speed only on flat ground· Travel slowly at low speed if it is impossible to avoid going over obstacles

8. SPECIFICATIONS FOR MAJOR COMPONENTS

1) ENGINE

Item	Specification
Maker / Model	CUMMINS / X12
Type	4-cycle, turbocharged, charge air cooled, electronic controlled diesel engine
Cooling method	Water cooled
Number of cylinders and arrangement	6 cylinders, in-line
Firing order	1-5-3-6-2-4
Combustion chamber type	Direct injection type
Cylinder bore × stroke	132 × 144 mm (5.2" × 5.67")
Displacement	11.8 ℓ (720 cu in)
Compression ratio	17 : 1
Gross power	335 Hp (250 kW) at 2100 rpm
Net power	330 Hp (246 kW) at 2100 rpm
Max. power	370 Hp (276 kW) at 1800 rpm
Peak torque	1674 N · m (1235 lbf · ft) at 1400 rpm
Engine oil quantity	34 ℓ (9 U.S. gal)
Wet weight	860 kg (1896 lb)
Starter motor	24 V-7.5 kW
Alternator	24 V-110 A

2) MAIN PUMP

Item	Specification
Type	Variable displacement tandem axis piston pumps
Capacity	2 × 225 cc/rev
Maximum pressure	330 kgf/cm ² (4690 psi) [360 kgf/cm ² (5120 psi)]
Rated oil flow	2 × 405 ℓ /min (107 U.S. gpm/89.1 U.K. gpm)
Rated speed	1800 rpm

[] : Power boost

3) GEAR PUMP

Item	Specification
Type	Fixed displacement gear pump single stage
Capacity	13.7 cc/rev
Maximum pressure	40 kgf/cm ² (570 psi)
Rated oil flow	24.7 ℓ /min (6.5 U.S. gpm/5.4 U.K. gpm)

4) MAIN CONTROL VALVE

Item	Specification	
Type	9 spools	
Operating method	Hydraulic pilot system	
Main relief valve pressure	330 kgf/cm ² (4690 psi) [360 kgf/cm ² (5120 psi)]	
Port relief valve pressure	Boom	400 kgf/cm ² (5690 psi)
	Arm	400 kgf/cm ² (5690 psi)
	Bucket	400 kgf/cm ² (5690 psi)

[] : Power boost

5) SWING MOTOR

Item	Specification	
Type	Two fixed displacement axial piston motor	
Capacity	142.8 cc/rev	
Relief pressure	285 kgf/cm ² (4054 psi)	
Braking system	Automatic, spring applied hydraulic released	
Braking torque	63 kgf · m (456 lbf · ft)	
Brake release pressure	Cranking	20.9 kgf · m (151 lbf · ft)
	Full stroke	35.5 kgf · m (257 lbf · ft)
Reduction gear type	2 - stage planetary	

6) TRAVEL MOTOR (Type 1, 2)

Item	Specification
Type	Variable displacement axial piston motor
Capacity	281.7/175.9 cc/rev
Relief pressure	360 kgf/cm ² (5120 psi)
Braking system	Auto matic, spring applied hydraulic released
Braking torque	119.7 kgf · m (866 lbf · ft)
Brake release pressure	11.3~15.7 kgf/cm ² (161~223 psi)
Reduction gear type	2-stage planetary

7) CYLINDER

Item		Specification	
Boom cylinder	Bore dia × Stroke	∅170 × 1580 mm	
	Cushion	Extend only	
Arm cylinder	Bore dia × Stroke	∅190 × 1850 mm	
	Cushion	Extend and retract	
Bucket cylinder	Bore dia × Stroke	HX500LT3	∅160 × 1360 mm
		HX500LT3★ HX520LT3	∅170 × 1360 mm
	Cushion	Extend only	

※ Discoloration of cylinder rod can occur when the friction reduction additive of lubrication oil spreads on the rod surface.

※ Discoloration does not cause any harmful effect on the cylinder performance.

★ Only for 6.55 m (21' 6") boom and 2.55 m (8' 4") arm.

9. RECOMMENDED OILS

HYUNDAI genuine lubricating oils have been developed to offer the best performance and service life for your equipment. These oils have been tested according to the specifications of HYUNDAI and, therefore, will meet the highest safety and quality requirements.

We recommend that you use only HYUNDAI genuine lubricating oils and grease officially approved by HYUNDAI.

Service point	Kind of fluid	Capacity ℓ (U.S. gal)	Ambient temperature °C (°F)						
			-50 (-58)	-30 (-22)	-20 (-4)	-10 (14)	0 (32)	10 (50)	20 (68)
Engine oil pan	Engine oil	34.0 (9.0)	★SAE 5W-40						
			SAE 30						
			SAE 10W						
			SAE 10W-30						
			SAE 15W-40						
Swing drive	Gear oil	7.0 (1.8) × 2	★SAE 75W-90						
Final drive		12.5 (3.3) × 2	SAE 80W-90						
Hydraulic tank	Hydraulic oil	Tank : 275 (72.6)	★ISO VG 15						
			ISO VG 32						
		System : 499 (132)	ISO VG 46						
			ISO VG 68						
Fuel tank	Diesel fuel★1	660 (174)	★ASTM D975 NO.1						
			ASTM D975 NO.2						
Fitting (grease nipple)	Grease	As required	★NLGI NO.1						
			NLGI NO.2						
Radiator (reservoir tank)	Mixture of antifreeze and soft water★2	43.0 (11.4)	Ethylene glycol base permanent type (50 : 50)						
			★Ethylene glycol base permanent type (60 : 40)						

SAE : Society of Automotive Engineers

API : American Petroleum Institute

ISO : International Organization for Standardization

NLGI : National Lubricating Grease Institute

ASTM : American Society of Testing and Material

DEF : Diesel Exhaust Fluid DEF compatible with AdBlue®

★ : Cold region (Russia, CIS, Mongolia)

★1 : Ultra low sulfur diesel
- sulfur content ≤ 15 ppm

★2 : Soft water
City water or distilled water

- ※ Using any lubricating oils other than HYUNDAI genuine products may lead to a deterioration of performance and cause damage to major components.
- ※ Do not mix HYUNDAI genuine oil with any other lubricating oil as it may result in damage to the systems of major components.
- ※ Do not use any engine oil other than that specified above, as it may clog the diesel particulate filter(DPF).
- ※ For HYUNDAI genuine lubricating oils and grease for use in regions with extremely low temperatures, please contact your local HYUNDAI dealers.