

SECTION 3 HYDRAULIC SYSTEM

Group 1 Hydraulic Circuit	3-1
Group 2 Main Circuit	3-2
Group 3 Pilot Circuit	3-5
Group 4 Single Operation	3-14
Group 5 Combined Operation	3-24

GROUP 1 HYDRAULIC CIRCUIT

1. HYDRAULIC CIRCUIT (1/2)

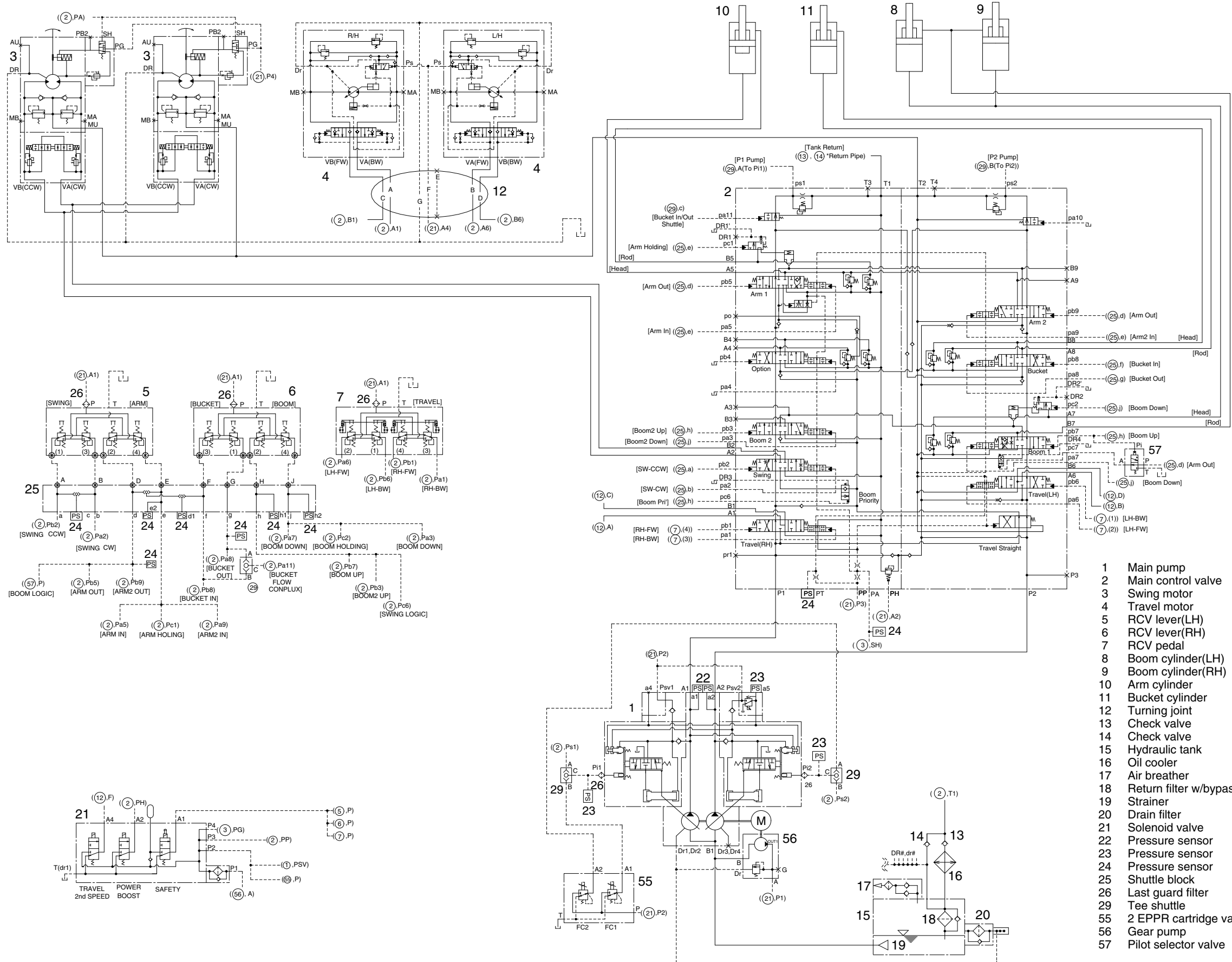

- 1 Main pump
- 2 Main control valve
- 3 Swing motor
- 4 Travel motor
- 5 RCV lever(LH)
- 6 RCV lever(RH)
- 7 RCV pedal
- 8 Boom cylinder(LH)
- 9 Boom cylinder(RH)
- 10 Arm cylinder
- 11 Bucket cylinder
- 12 Turning joint
- 13 Check valve
- 14 Check valve
- 15 Hydraulic tank
- 16 Oil cooler
- 17 Air breather
- 18 Return filter w/bypass valve
- 19 Strainer
- 20 Drain filter
- 21 Solenoid valve
- 22 Pressure sensor
- 23 Pressure sensor
- 24 Pressure sensor
- 25 Shuttle block
- 26 Last guard filter
- 29 Tee shuttle
- 55 2 EPPR cartridge valve
- 56 Gear pump
- 57 Pilot selector valve

2. HYDRAULIC CIRCUIT (2/2)

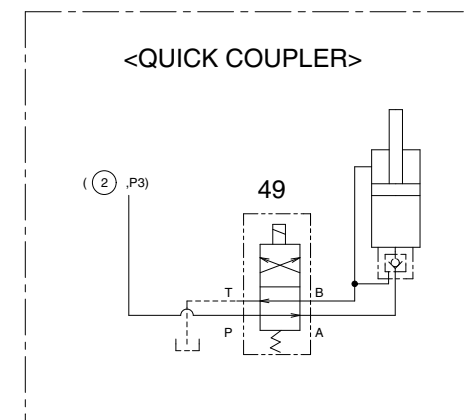
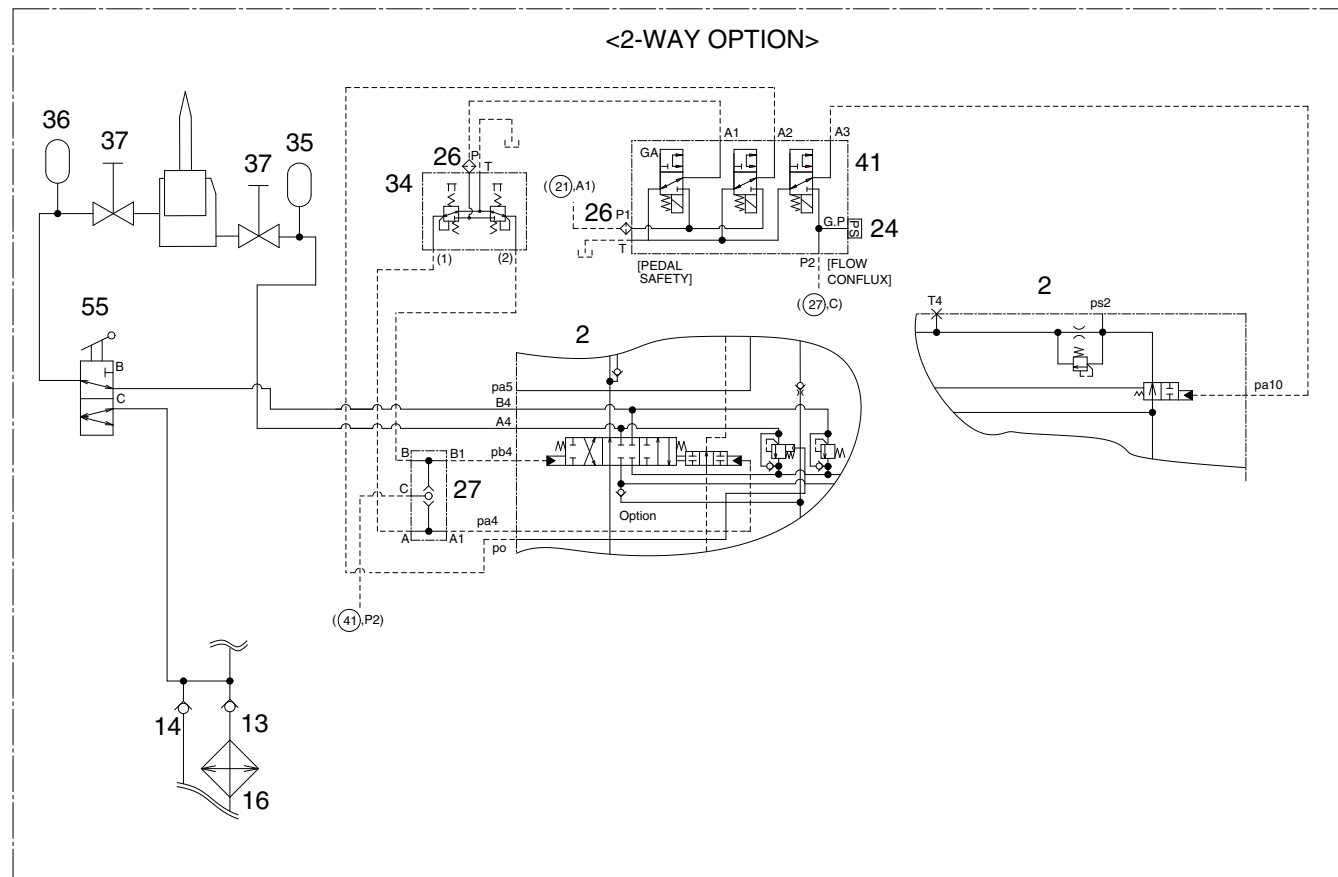
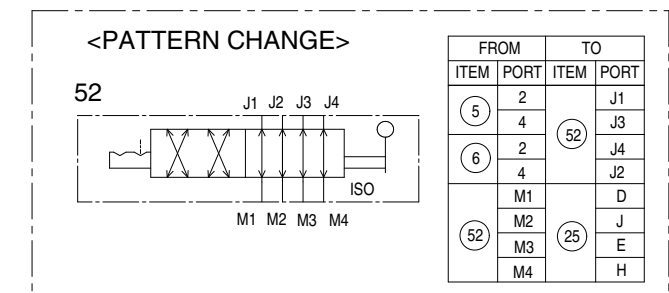
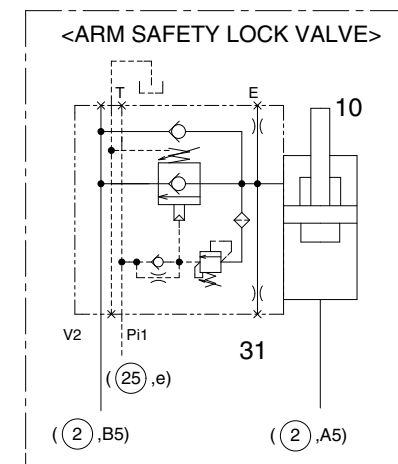
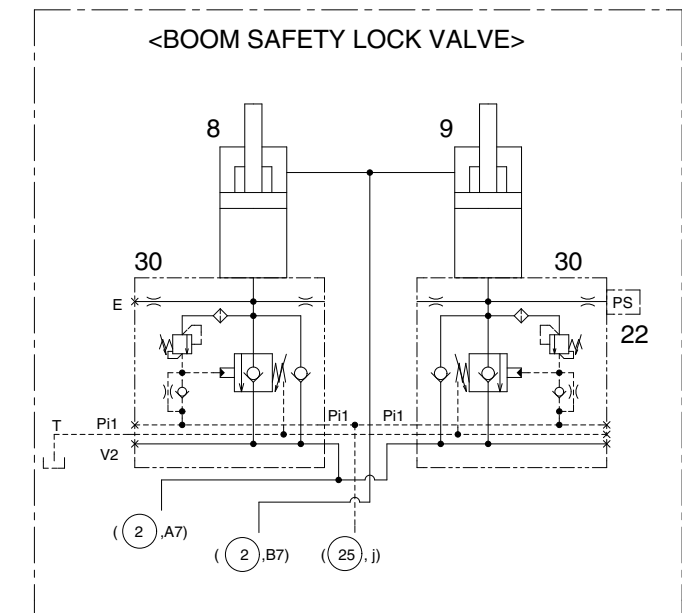
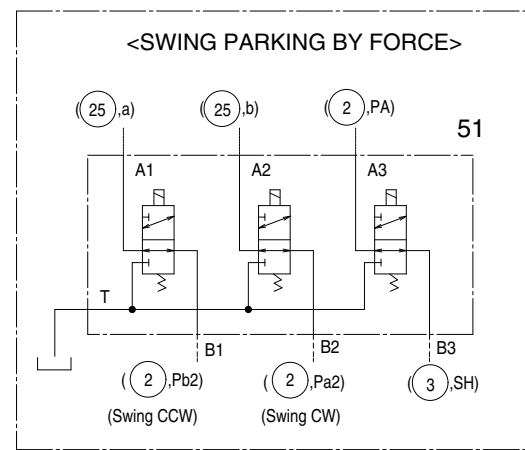
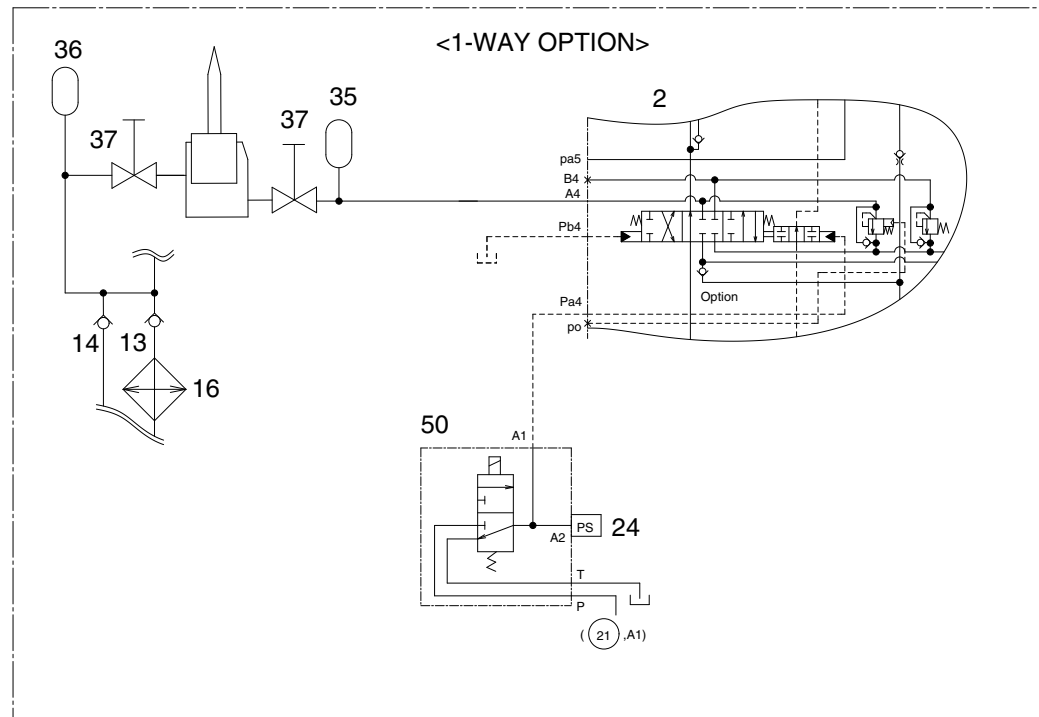

- 2 Main control valve
- 8 Boom cylinder(LH)
- 9 Boom cylinder(RH)
- 10 Arm cylinder
- 13 Check valve
- 14 Check valve
- 16 Oil cooler
- 22 Pressure sensor
- 24 Pressure sensor
- 26 Last guard filter
- 27 5 Shuttle assy(option)
- 30 Boom safety valve(option)
- 31 Arm safety valve(option)
- 34 2 Way pedal(option)
- 35 Accumulator(option)
- 36 Accumulator(option)
- 37 Stop valve(option)
- 41 Solenoid valve(option)
- 49 Solenoid valve(option)
- 50 Solenoid valve(option)
- 51 Solenoid valve(option)
- 52 Pattern change valve(option)
- 55 3 Way joint

GROUP 2 MAIN CIRCUIT

The main hydraulic circuit consists of suction circuit, delivery circuit, return circuit and drain circuit. The hydraulic system consists of one main pump, one control valve, one swing motor, four cylinders and two travel motors.

The swash plate type variable displacement tandem axial piston pump is used as the main pump and is driven by the engine at ratio 1.0 of engine speed.

1. SUCTION AND DELIVERY CIRCUIT

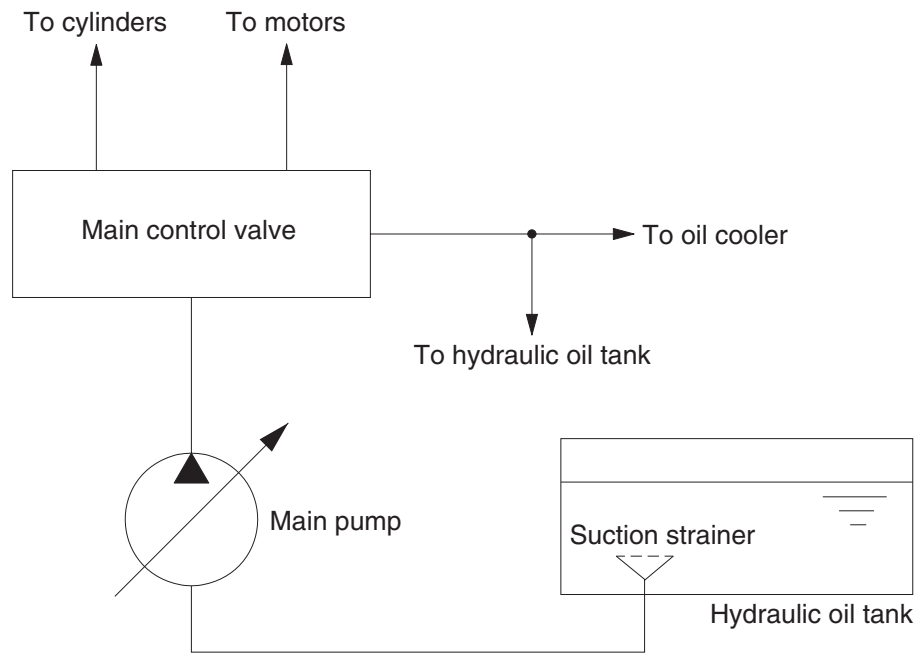

140L3CI01

The pumps receive oil from the hydraulic tank through a suction strainer. The discharged oil from the pump flows into the control valve and goes out the tank ports.

The oil discharged from the main pump flows to the actuators through the control valve.

The control valve controls the hydraulic functions.

The return oil from the actuators flows to the hydraulic tank through the control valve and the oil cooler.

2. RETURN CIRCUIT

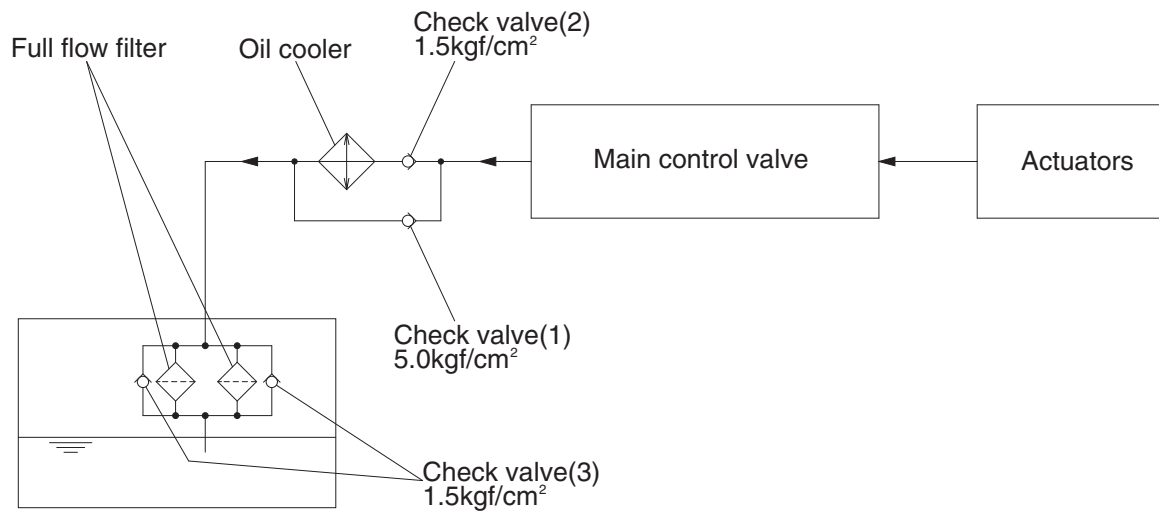

45073CI02

All oil from each actuator returns to the hydraulic tank through the control valve.

The bypass check valves are provided in the return circuit.

The setting pressure of bypass check valves are 1.5 kgf/cm² (21 psi) and 5.0 kgf/cm² (71 psi). Usually, oil returns to the hydraulic tank from the left side of control valve through oil cooler.

When oil temperature is low, viscosity becomes higher and flow resistance increases when passing through the oil cooler. The oil pressure exceeds 5.0 kgf/cm² (71 psi), the oil returns directly to the hydraulic tank, resulting in the oil temperature being raised quickly at an appropriate level.

When the oil cooler is clogged, the oil returns directly to the hydraulic tank through bypass check valve (1).

The full-flow filter and bypass relief valve are provided in the hydraulic tank.

The oil from right and left side of control valve is combined and filtered by the return filter. A bypass relief valve is provided in the full-flow filter.

When the filter element is clogged, the bypass relief valve opens at 1.5 kgf/cm² (21 psi) differential pressure.

3. DRAIN CIRCUIT

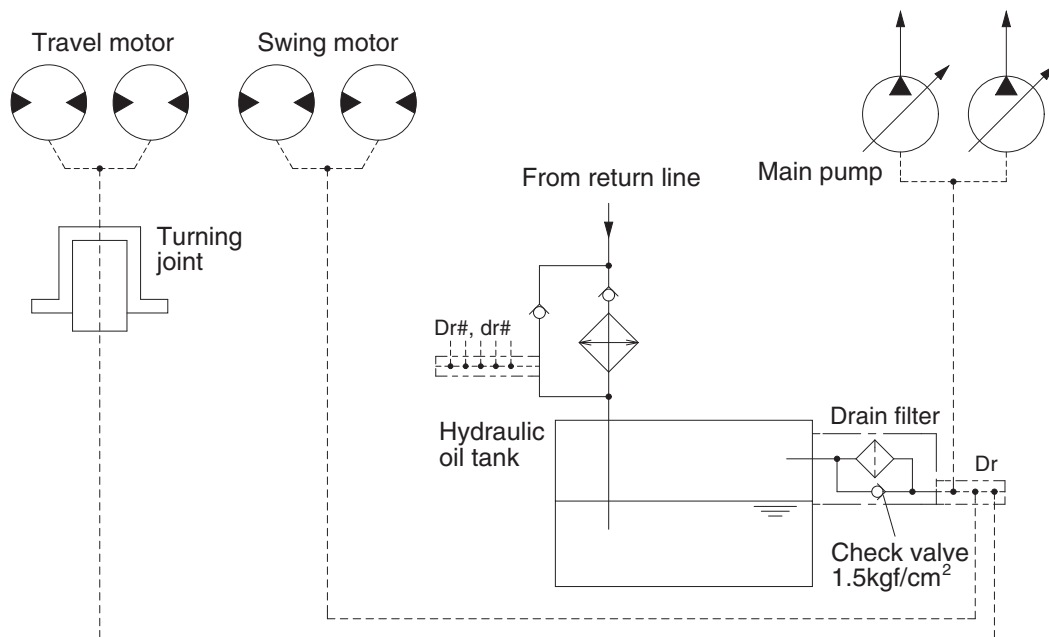

480S3CI02

Besides internal leaks from the motors and main pump, the oil for lubrication circulates. These oil have to be fed to the hydraulic tank passing through drain filter and full flow filter in the hydraulic tank. When the drain oil pressure exceed 1.5 kgf/cm² (21 psi), the oil returns to the hydraulic tank directly.

1) TRAVEL MOTOR DRAIN CIRCUIT

Oil leaking from the right and left travel motors come out of the drain ports provided in the respective motor casing and join with each other. These oils pass through the turning joint and return to the hydraulic tank after being filtered by drain filter.

2) SWING MOTOR DRAIN CIRCUIT

Oil leaking from the swing motors come out and return to the hydraulic tank passing through drain filter.

3) MAIN PUMP DRAIN CIRCUIT

Oil leaking from main pump come out and return to the hydraulic tank passing through drain filter.

GROUP 3 PILOT CIRCUIT

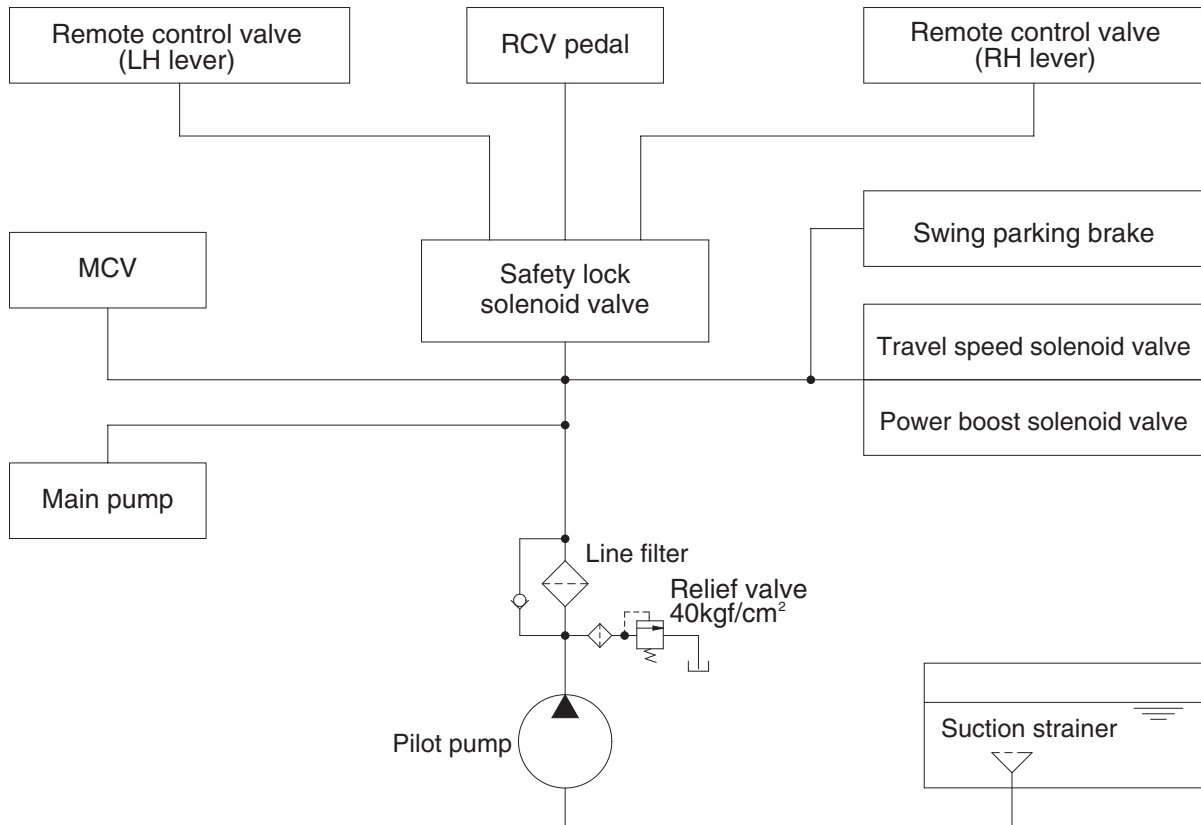

480S3CI03

The pilot circuit consists of suction circuit, delivery circuit and return circuit.

The pilot pump is provided with relief valve, receives the oil from the hydraulic tank through the suction strainer.

The discharged oil from the pilot pump flows to the remote control valve through line filter, EPPR valve, solenoid valve assemblies, swing parking brake, main control valve and safety lock solenoid valve.

1. SUCTION, DELIVERY AND RETURN CIRCUIT

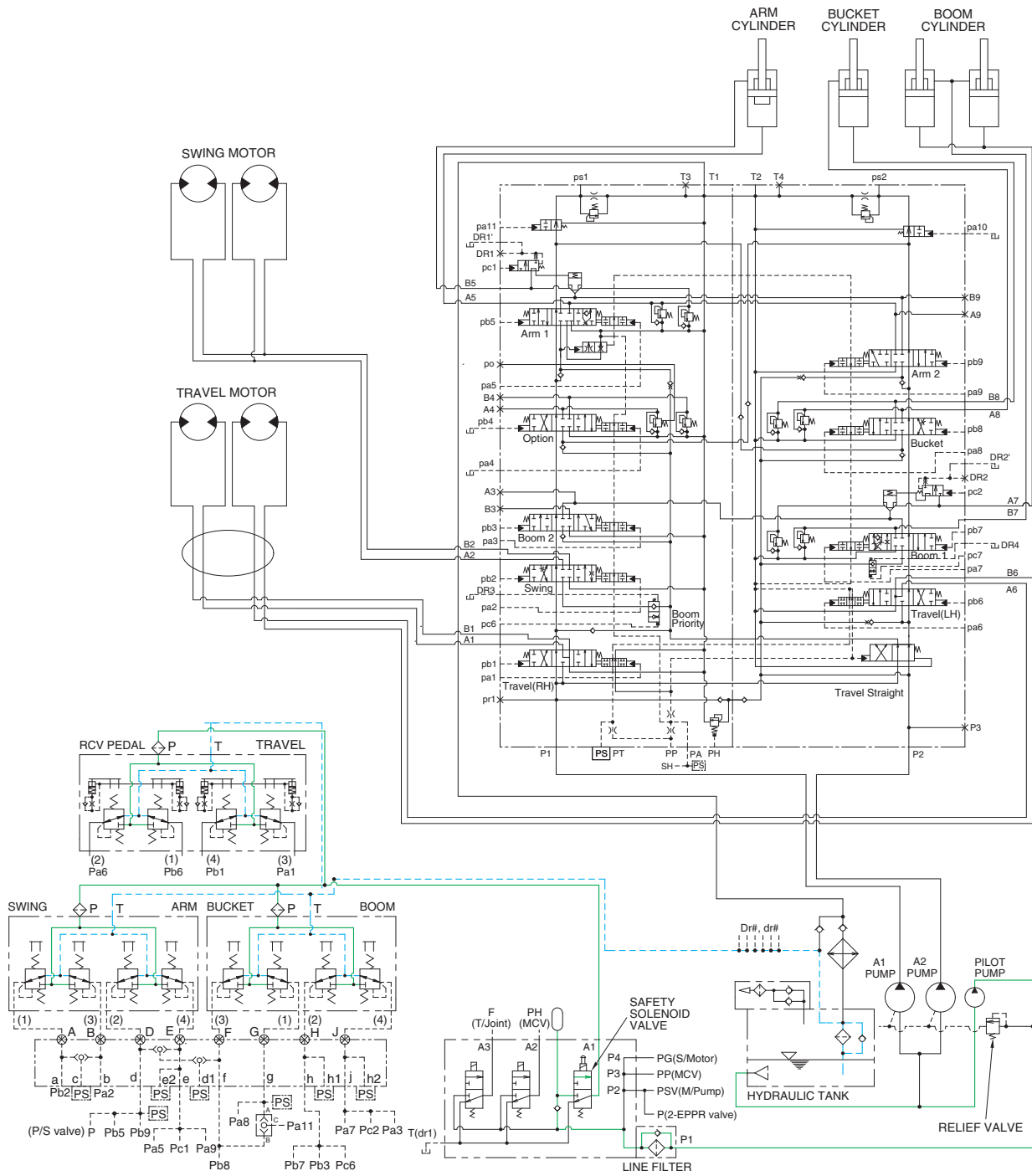

480S3HC02

The pilot pump receive oil from the hydraulic tank. The discharged oil from the pilot pump flows to the safety solenoid valve through the line filter. The oil is filtered by the line filter. The pilot relief valve is provided in the pilot pump for limiting the pilot circuit pressure. The oil filtered by line filter flows remote control valve through safety solenoid valve. The return oil from remote control valve returned to hydraulic tank through return filter.

2. SAFETY SOLENOID VALVE (SAFETY LEVER)

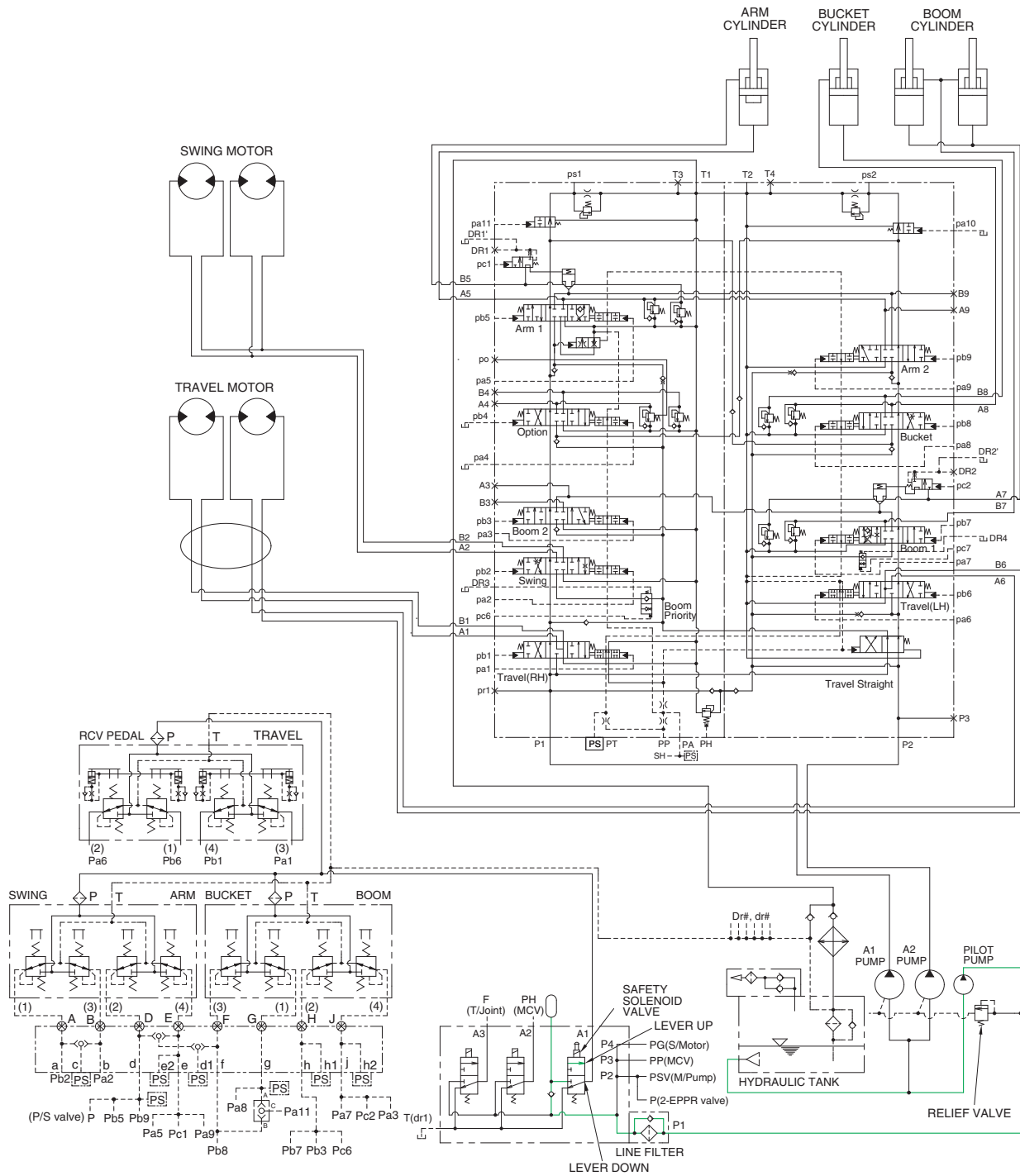

480S3HC03

When the lever of the safety solenoid valve is moved downward, oil flows into the remote control valve through solenoid valve and line filter.

When the lever of the safety solenoid valve moved upward, oil does not flows into the remote control valve, because of blocked by the spool.

3. BOOM PRIORITY SYSTEM

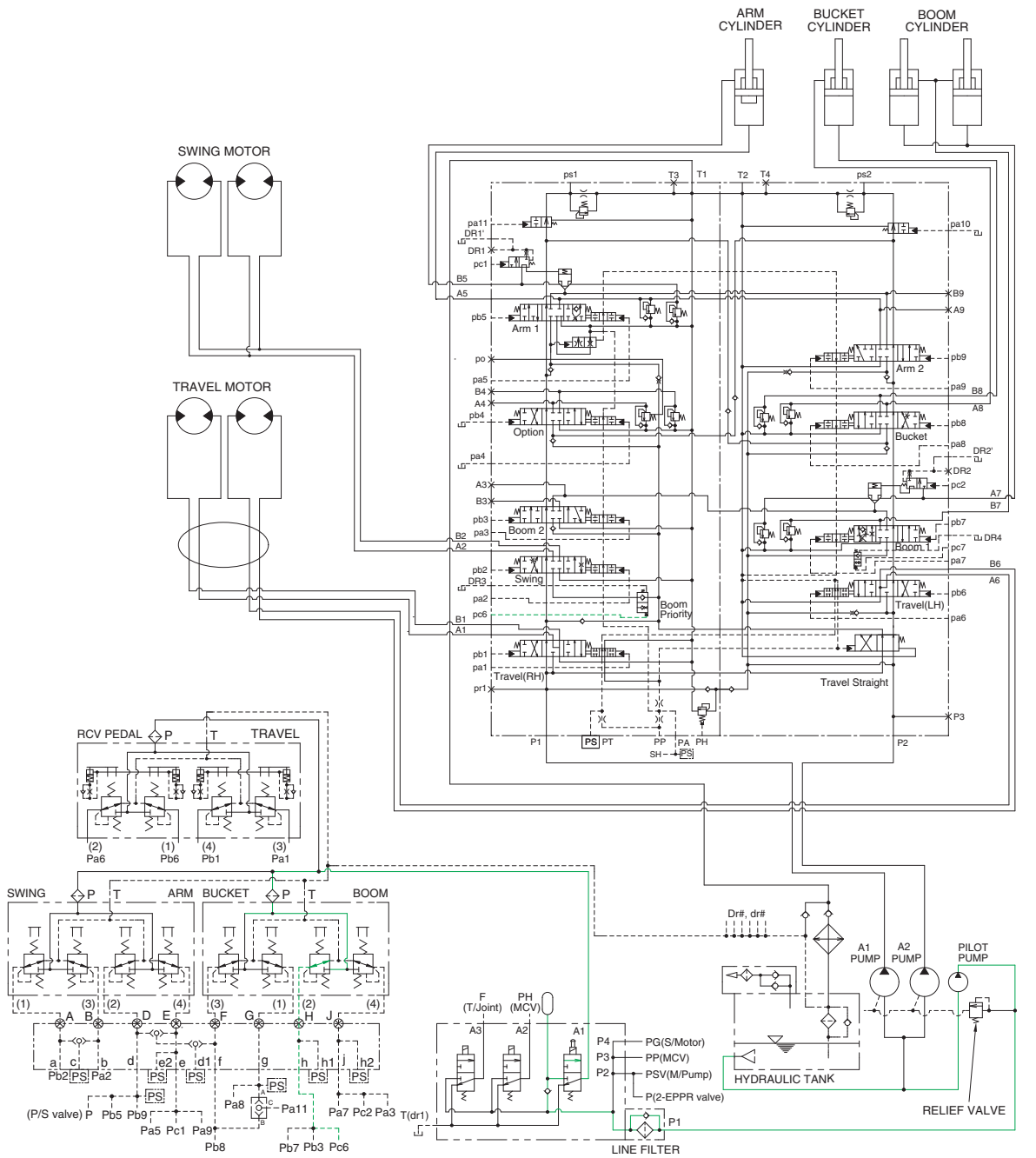

480S3HC04

When carrying out the combined operation of swing and boom up, the boom up operating speed is lowered then normal operation.

To increase working efficiency, swing speed reducing system is used.

When the boom up control lever is operated, the pilot oil from the pilot oil pump flows into the Pc6 and shifts the swing logic valve in the main control valve to upper position.

Then, the oil flow rate to the swing motor is decreased and the boom up speed is increased.

This is called the boom priority system.

4. TRAVEL SPEED CONTROL SYSTEM

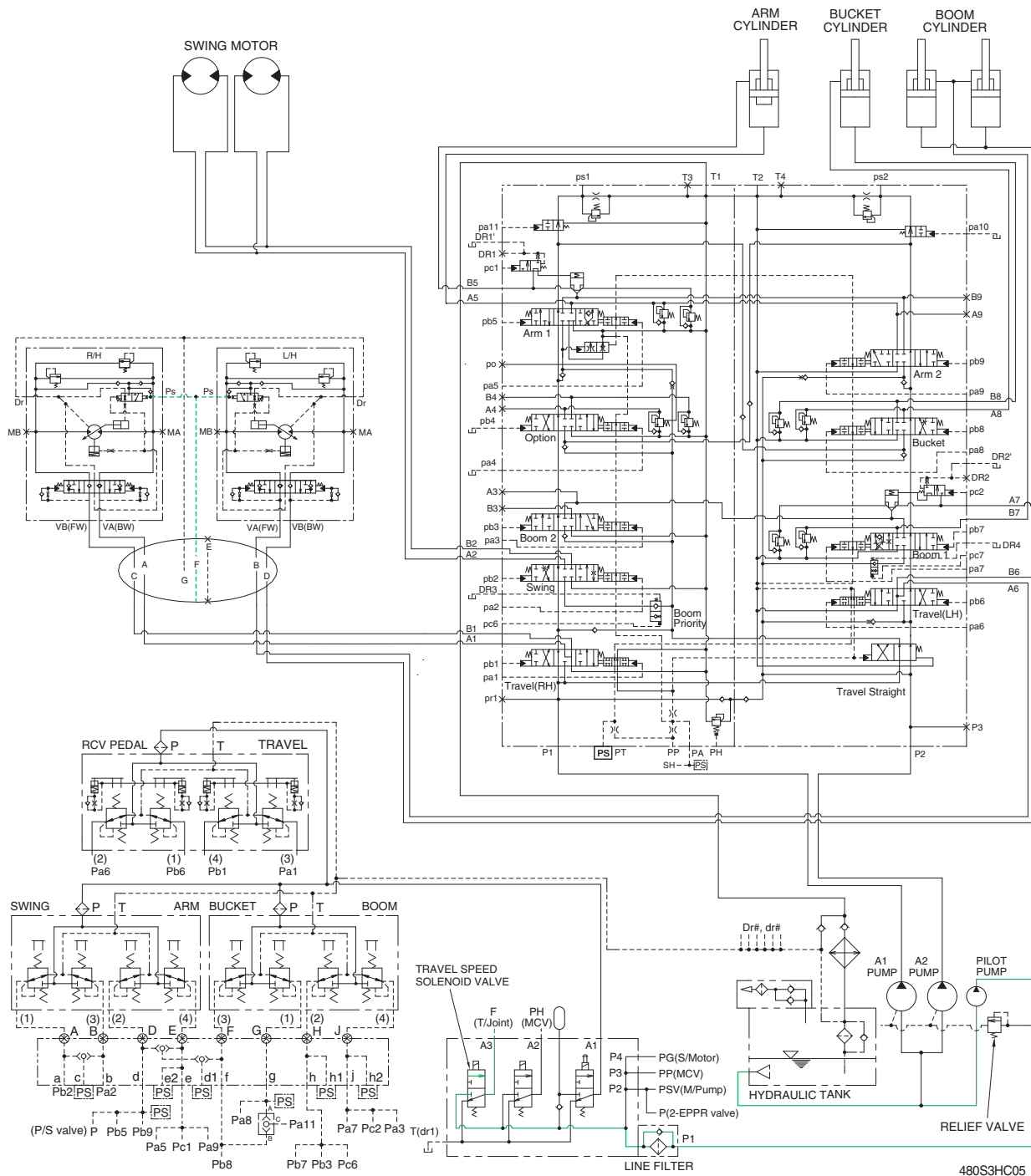

When the travel speed solenoid valve was placed in the Hi position, the pressure oil from pilot pump through line filter flows to port **Ps** of travel speed change over valve, and the control piston is pushed up, thus minimizing the displacement.

When the travel speed solenoid valve was placed in the Lo position, the oil of **Ps** port return to the tank and the control piston is returned, thus maximizing the displacement.

5. MAIN RELIEF PRESSURE CHANGE CIRCUIT

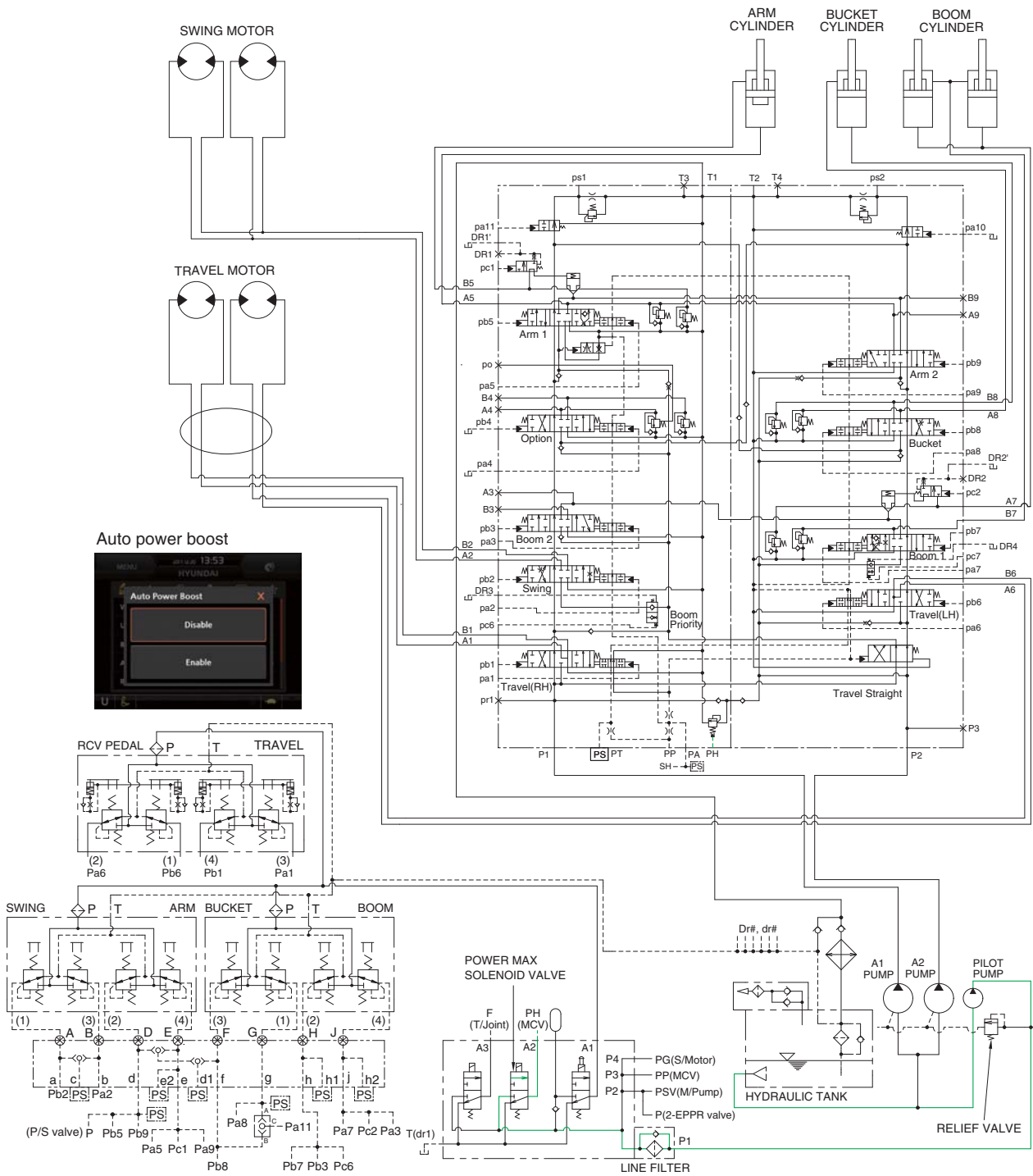

480S3HC06

When the power max switch on the left control lever is pushed ON, the power max solenoid valve is actuated, the discharged oil from the pilot pump into PH port of the main relief valve of main control valve ; Then the setting pressure of the main control valve is raises from 330 kgf/cm² to 360 kgf/cm² for increasing the digging power. And even when press continuously, it is canceled after 8 seconds.

6. SWING PARKING BRAKE RELEASE

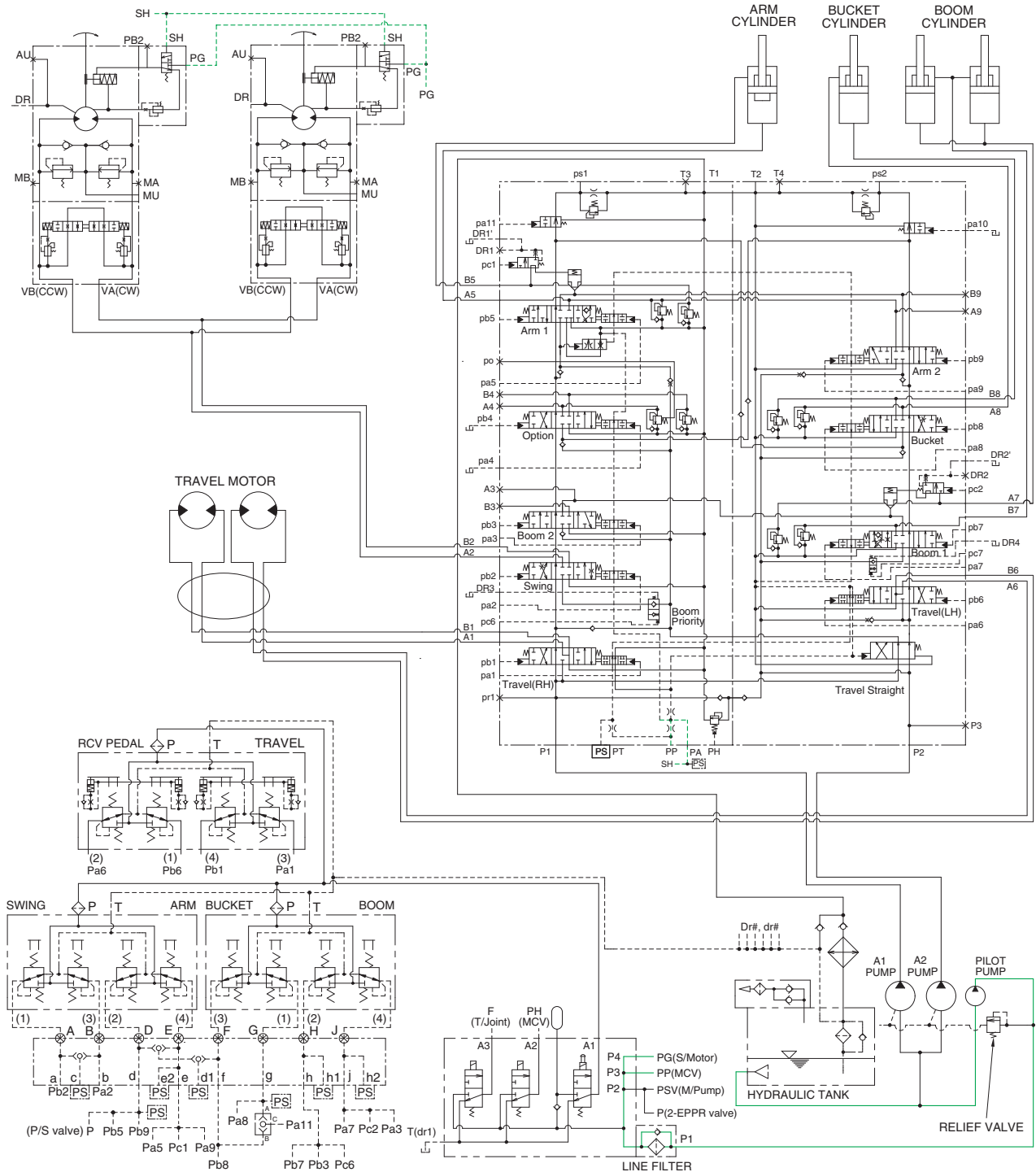

480S3HC07

When one of the RCV lever (except travel lever) is tilted, the pilot oil flows into SH port through main control valve.

This pressure moves spool so, discharged oil from pilot valve flows to swing motor PG port.

This pressure is applied to swing motor disc, thus the brake is released.

When all of the RCV lever are set in the neutral position, oil in the swing motor disc cylinder is drained, thus the brake is applied.

GROUP 4 SINGLE OPERATION

1. BOOM UP OPERATION

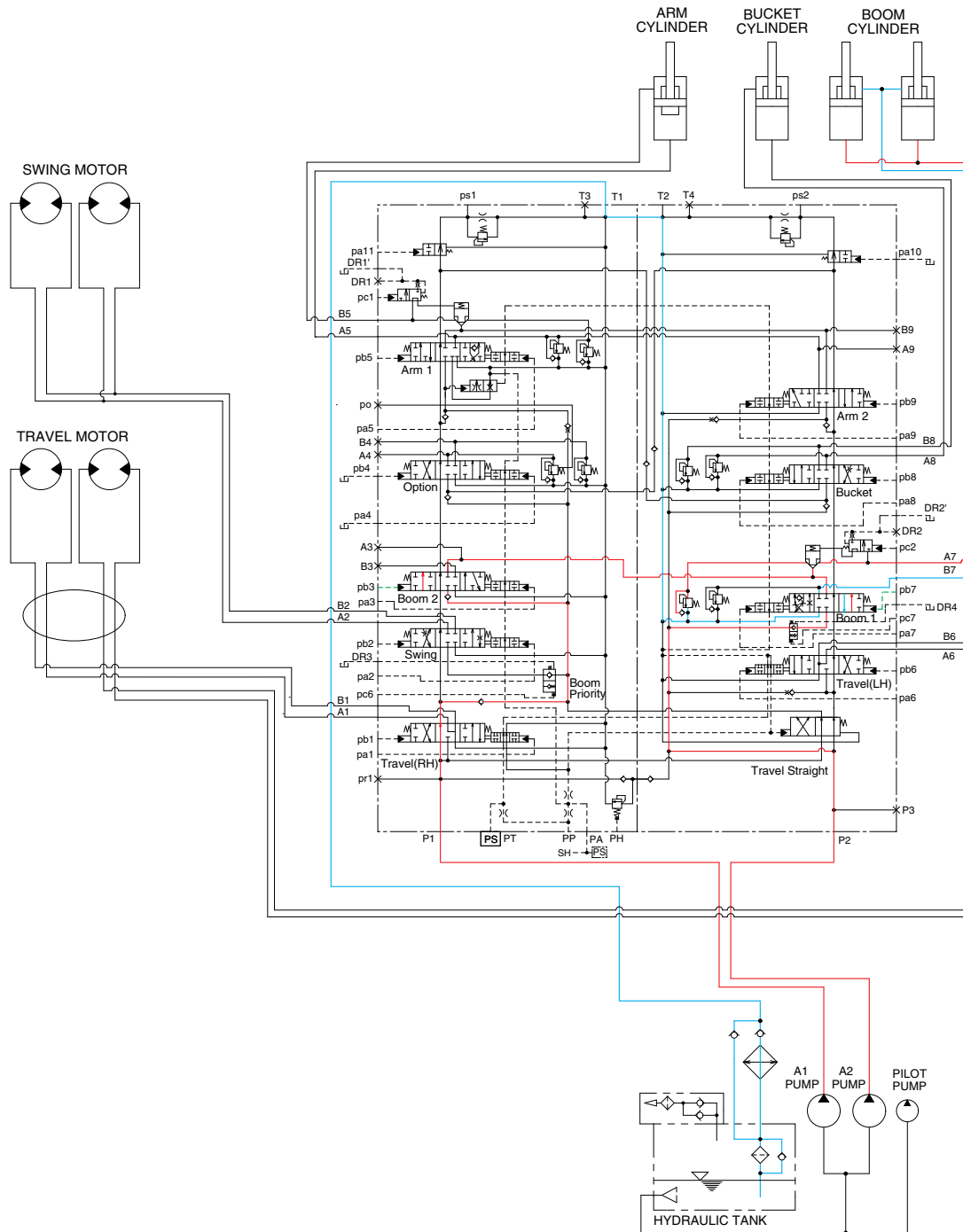

480S3HC10A

When the RH control lever is pulled back, the boom spools in the main control valve are moved to the up position by the pilot oil pressure from the remote control valve.

The oil from the A1 and A2 pump flows into the main control valve and then goes to the large chamber of boom cylinders.

At the same time, the oil from the small chamber of boom cylinders returns to the hydraulic oil tank through the boom 1 spool in the main control valve. When this happens, the boom goes up.

The excessive pressure in the boom cylinder bottom end circuit is prevented by relief valve.

When the boom is up and the control lever is returned to neutral position, the circuit for the holding pressure at the bottom end of the boom cylinder is closed by the boom holding valve.

This prevents the hydraulic drift of boom cylinder.

2. BOOM DOWN OPERATION

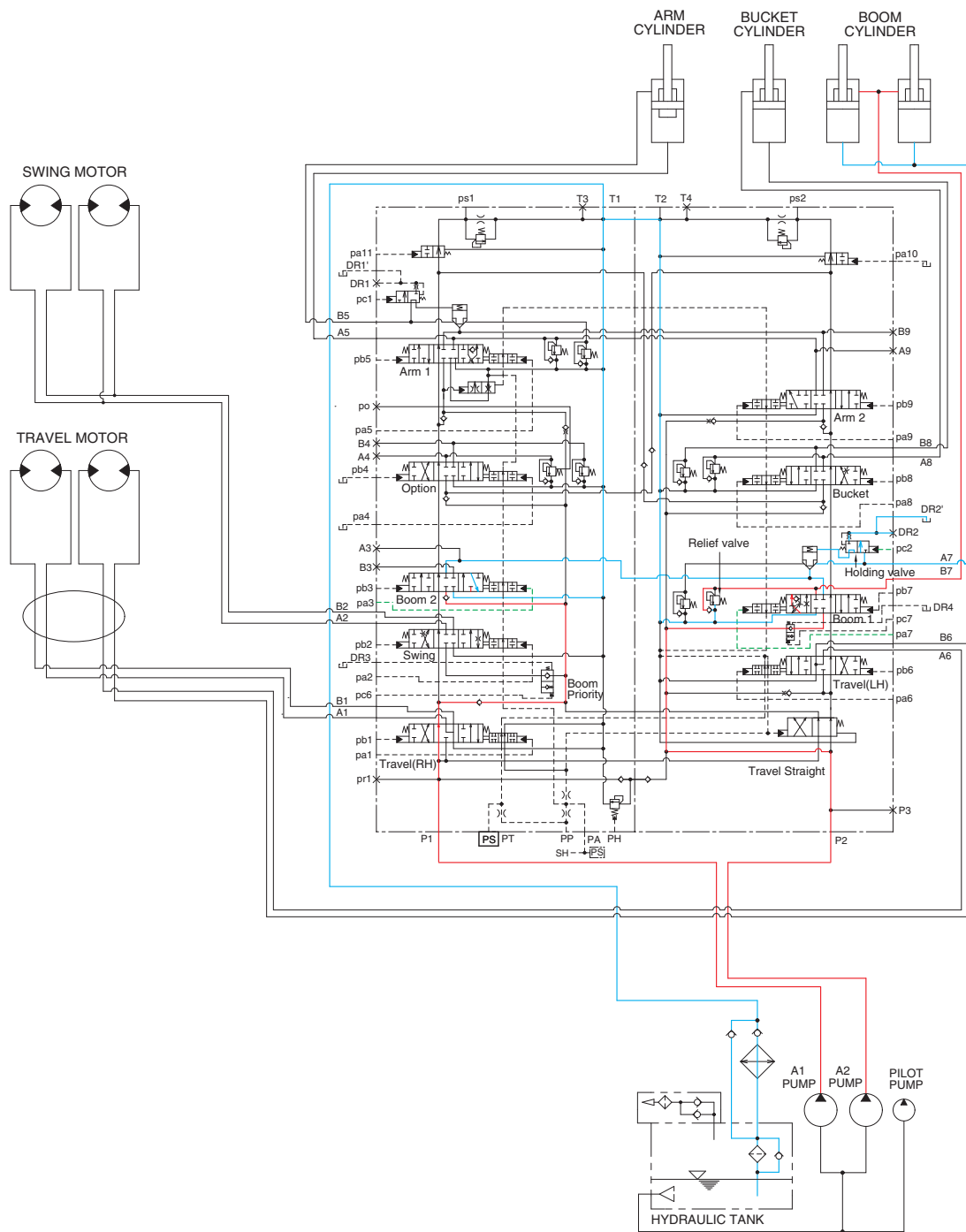

480S3HC11

When the RH control lever is pushed forward, the boom spools in the main control valve are moved to the down position by the pilot oil pressure from the remote control valve.

The oil from the A2 pump flows into the main control valve and then goes to the small chamber of boom cylinders. At the same time, the oil from the large chamber of boom cylinders returns to the hydraulic tank through the boom 1 and boom 2 spools in the main control valve.

When the down speed of boom is faster, the oil returned from the large chamber of boom cylinder combines with the oil from the rear pump, and flows into the small chamber of the boom cylinder.

This prevents cylinder cavitation by the negative pressure when the rear pump flow can not match the boom down speed. And the excessive pressure in the boom cylinder rod end circuit is prevented by the relief valve.

3. ARM IN OPERATION

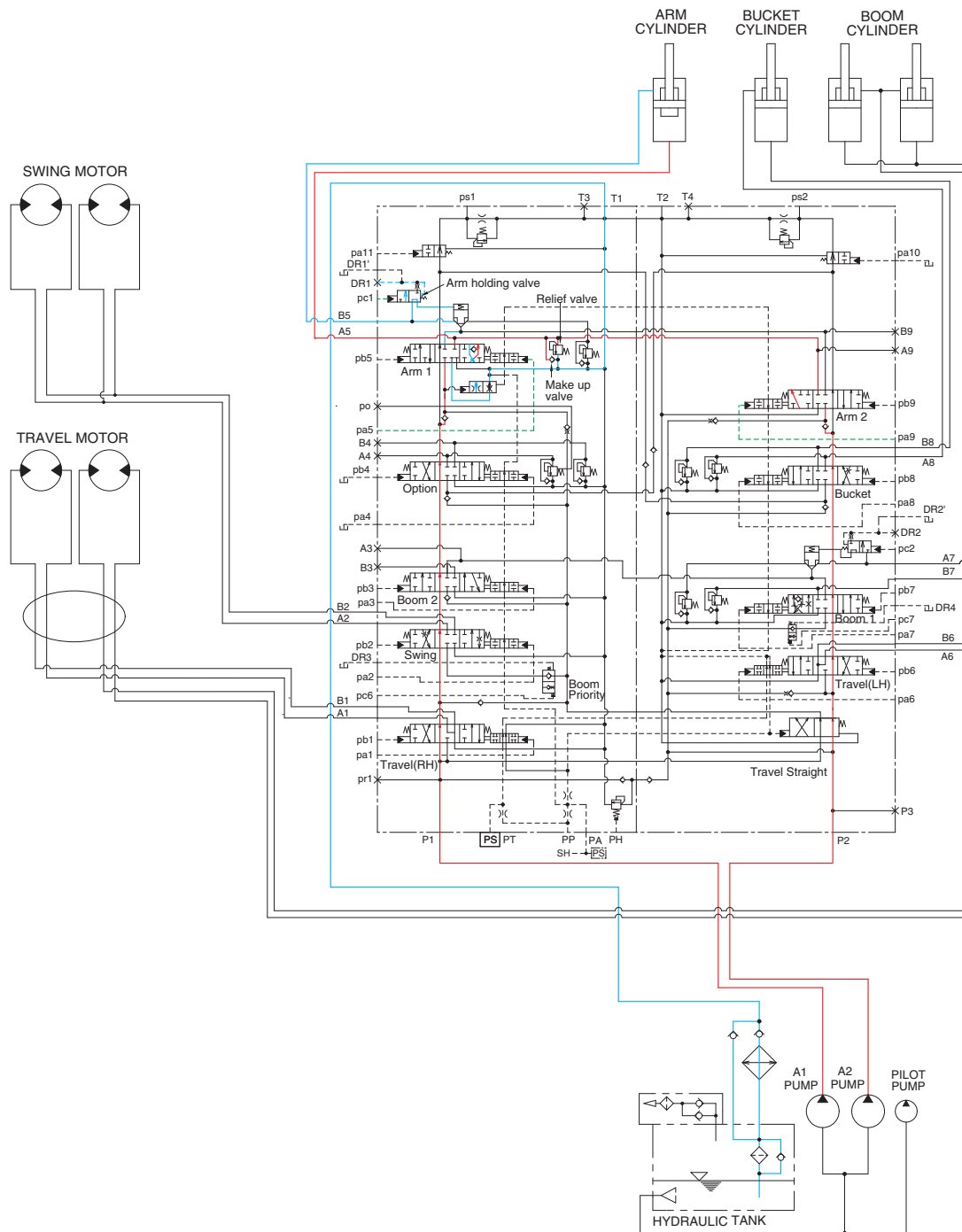

480S3HC12

When the LH control lever is pulled back, the arm spools in the main control valve are moved to roll in position by the pilot oil pressure from the remote control valve. The oil from the A1 and A2 pump flows into the main control valve and then goes to the large chamber of arm cylinder. At the same time, the oil from small chamber of arm cylinder returns to the hydraulic oil tank through the Arm 1 spool in the main control valve. When this happens, the arm rolls in. The excessive pressure in the arm cylinder head side is prevented by relief valve. The cavitation which will happen to the head side of the arm cylinder is also prevented by the make-up valve in the main control valve.

4. ARM OUT OPERATION

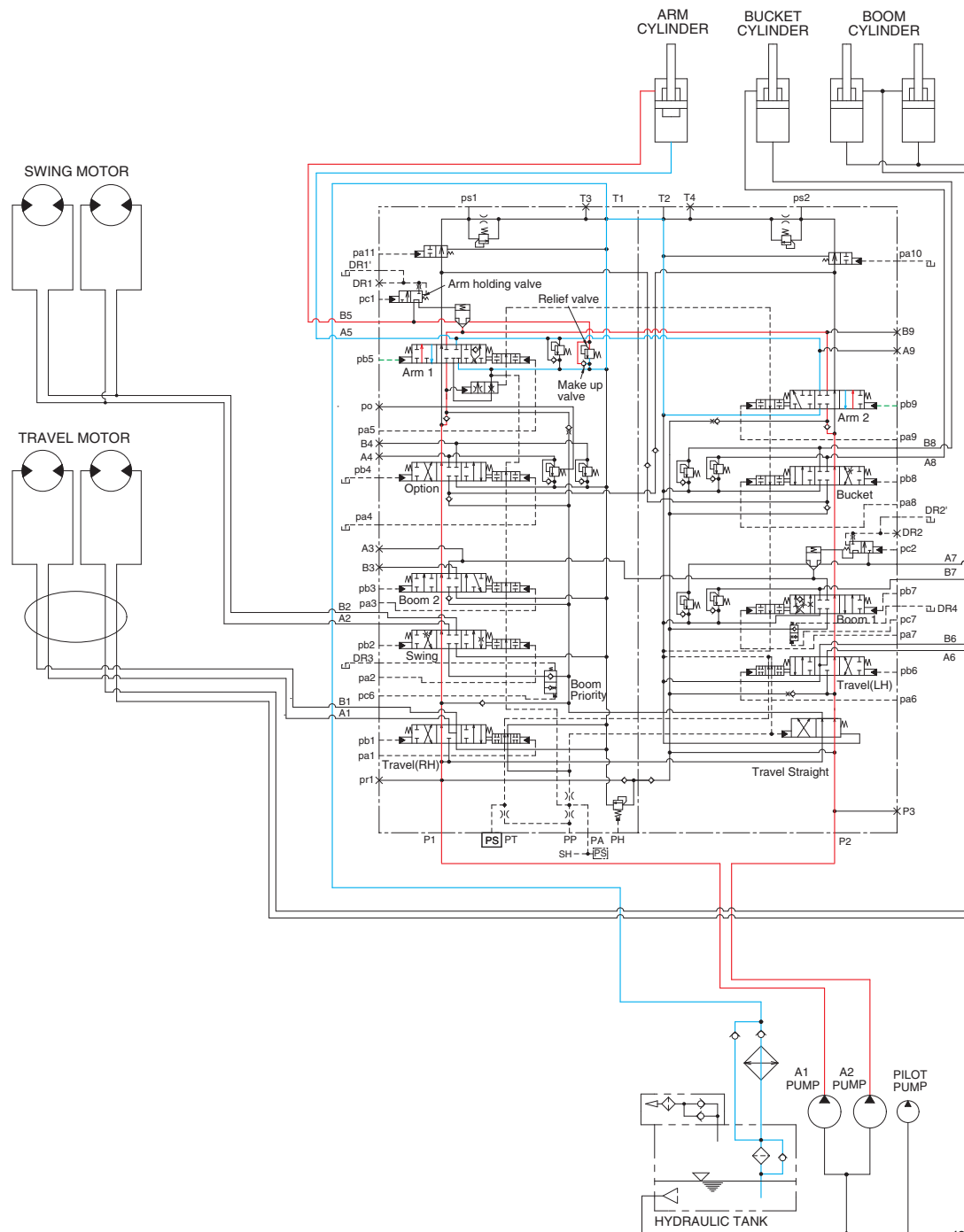

When the LH control lever is pushed forward, the arm spools in the main control valve are moved to the roll out position by the pilot oil pressure from the remote control valve.

The oil from the A1 and A2 pump flows into the main control valve and then goes to the small chamber of arm cylinder.

At the same time, the oil from the large chamber of arm cylinder returns to the hydraulic oil tank through the arm spools in the main control valve. When this happens, the arm rolls out.

The excessive pressure in the arm cylinder rod side is prevented by relief valve.

When the arm is roll out and the control lever is returned to neutral position, the circuit for the holding pressure at the rod side of the arm cylinder is closed by the arm holding valve.

The cavitation which will happen to the rod side of the arm cylinder is also prevented by the make-up valve in the main control valve.

5. BUCKET IN OPERATION

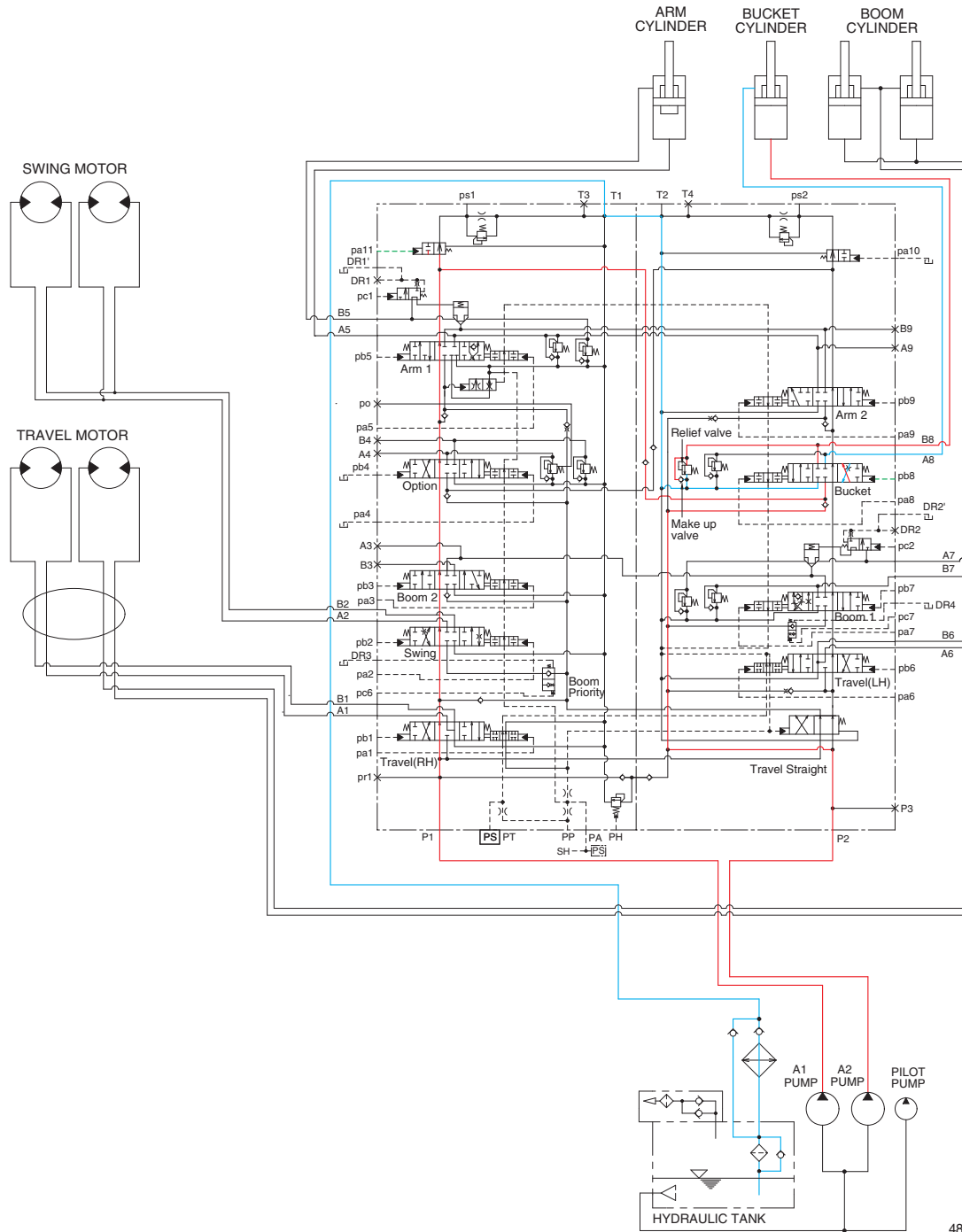

480S3HC14

When the RH control lever is pulled left, the bucket spool in the main control valve is moved to the roll in position by the pilot oil pressure from the remote control valve.

The oil from the A2 pump flows into the main control valve and then goes to the large chamber of bucket cylinder. The oil from the A1 pump flows into the large chamber of bucket cylinder through confluence oil passage in the main control valve by bypass cut pilot pressure (pa11).

At the same time, the oil from the small chamber of bucket cylinder returns to the hydraulic oil tank through the bucket spool in the main control valve. When this happens, the bucket rolls in.

The excessive pressure in the bucket cylinder head side is prevented by relief valve.

The cavitation which will happen to the head side of the bucket cylinder is also prevented by the make-up valve in the main control valve.

6. BUCKET OUT OPERATION

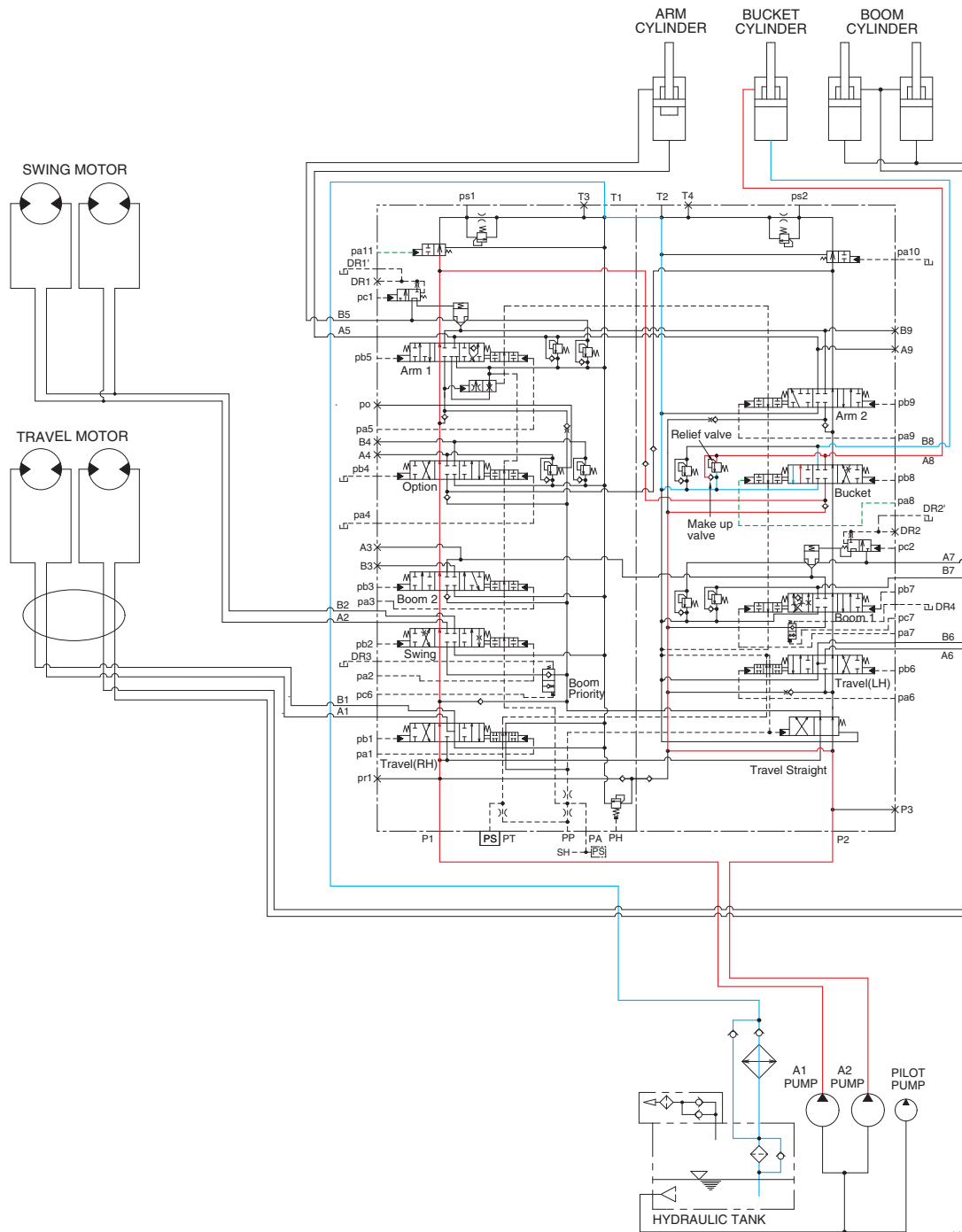

480S3HC15

When the RH control lever is pushed right, the bucket spool in the main control valve is moved to the roll out position by the pilot oil pressure from the remote control valve.

The oil from the A2 pump flows into the main control valve and then goes to the small chamber of bucket cylinder.

The oil from the A1 pump flows into the large chamber of bucket cylinder through confluence oil passage in the main control valve by bypass cut pilot pressure (pa11).

At the same time, the oil from the large chamber of bucket cylinder returns to the hydraulic oil tank through the bucket spool in the main control valve. When this happens, the bucket rolls out.

The excessive pressure in the bucket cylinder rod side is prevented by relief valve.

The cavitation which will happen to the rod side of the bucket cylinder is also prevented by the make-up valve in the main control valve.

7. SWING OPERATION

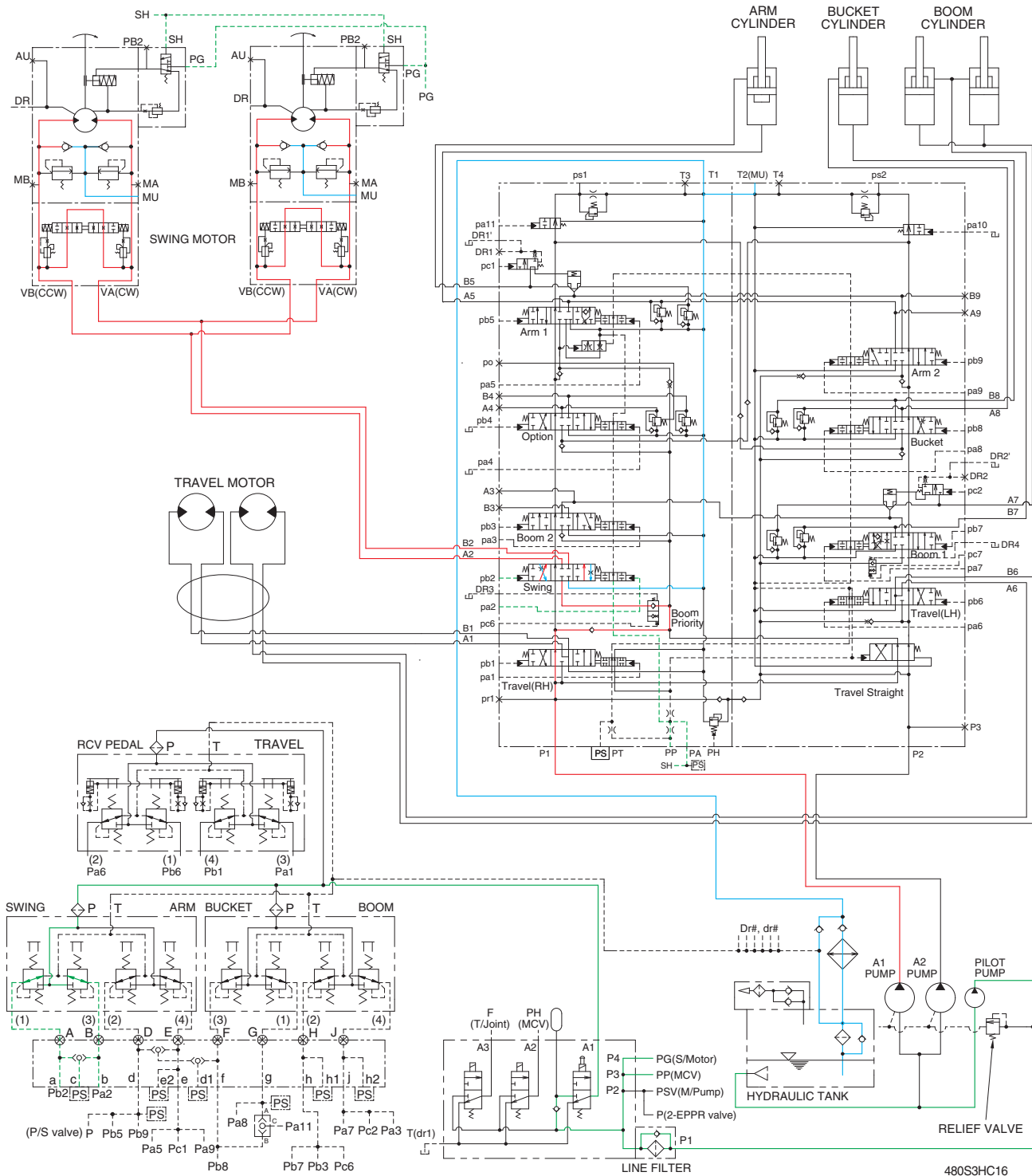

When the LH control lever is pushed left or right, the swing spool in the main control valve is moved to the left or right swing position by the pilot oil pressure from the remote control valve.

The oil from the A1 pump flows into the main control valve and then goes to the swing motor.

At the same time, the return oil from the swing motor returns to the hydraulic oil tank through the swing spool in the main control valve.

When this happens, the upper structure swings to the left or right.

The swing parking brake, make up valve and the motor brake valve are provided in the swing motor.

The cavitation which will happen to the swing motor is also prevented by the make up valve in the swing motor itself.

SWING CIRCUIT OPERATION

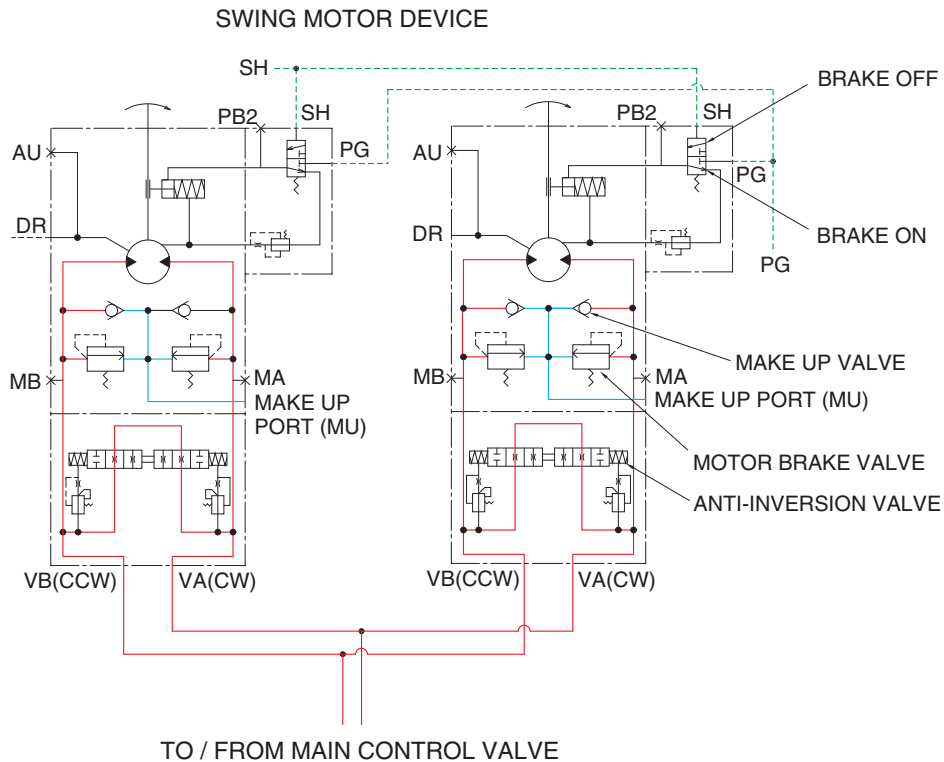

480S3HC17

1) MOTOR BRAKE VALVE

Motor brake valve for the swing motor limits to cushion the starting and stopping pressure of swing operation and controls the swing motor operating pressure.

2) MAKE UP VALVE

The make up valves prevent cavitation by supplying return oil to the vacuum side of the motor.

3) PARKING BRAKE

This is function as a parking brake only when all of the RCV lever (except travel pedal) are not operated.

PARKING BRAKE "OFF" OPERATION

The parking brake is released by the pilot pressure oil from the pilot pump.

When the RCV lever placed in the operating position, the pilot oil flows into SH port through the MCV. This pressure transferred to the brake release valve and the brake release valve is change over. Then the pilot oil pressure PG lift the brake piston and release the parking brake.

PARKING BRAKE "ON" OPERATION

When all of the RCV lever placed in the neutral position, the pressure of the pilot oil passage down. Then the brake release valve returned to the neutral position and the oil is returned from the brake piston to the tank. And the brake is set to 'ON'.

4) ANTI-INVERSION VALVE

This anti-inversion valve absorbs shocks produced as swing motion stops and reduced oscillation cause by swing motion.

8. TRAVEL FORWARD AND REVERSE OPERATION

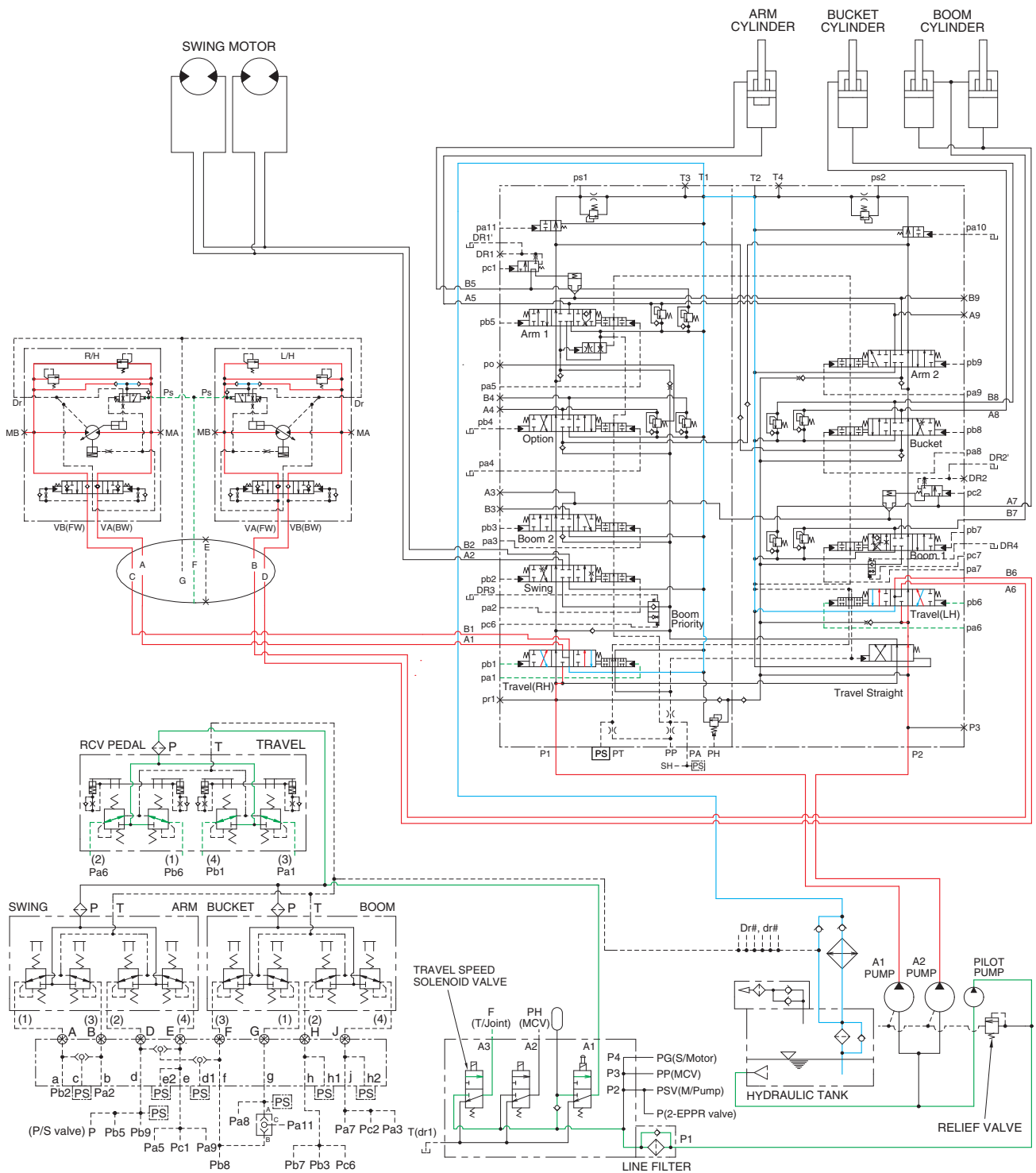

480S3HC18

When the travel levers are pushed forward or reverse position, the travel spools in the main control valve are moved to the forward or reverse travel position by the pilot oil pressure from the remote control valve.

The oil from the each pump flows into the main control valve and then goes to the each travel motor through the turning joint.

The return oil from both travel motors returns to the hydraulic oil tank through the turning joint and the travel spools in the main control valve.

When this happens, the machine moves to the forward or reverse.

TRAVEL CIRCUIT OPERATION

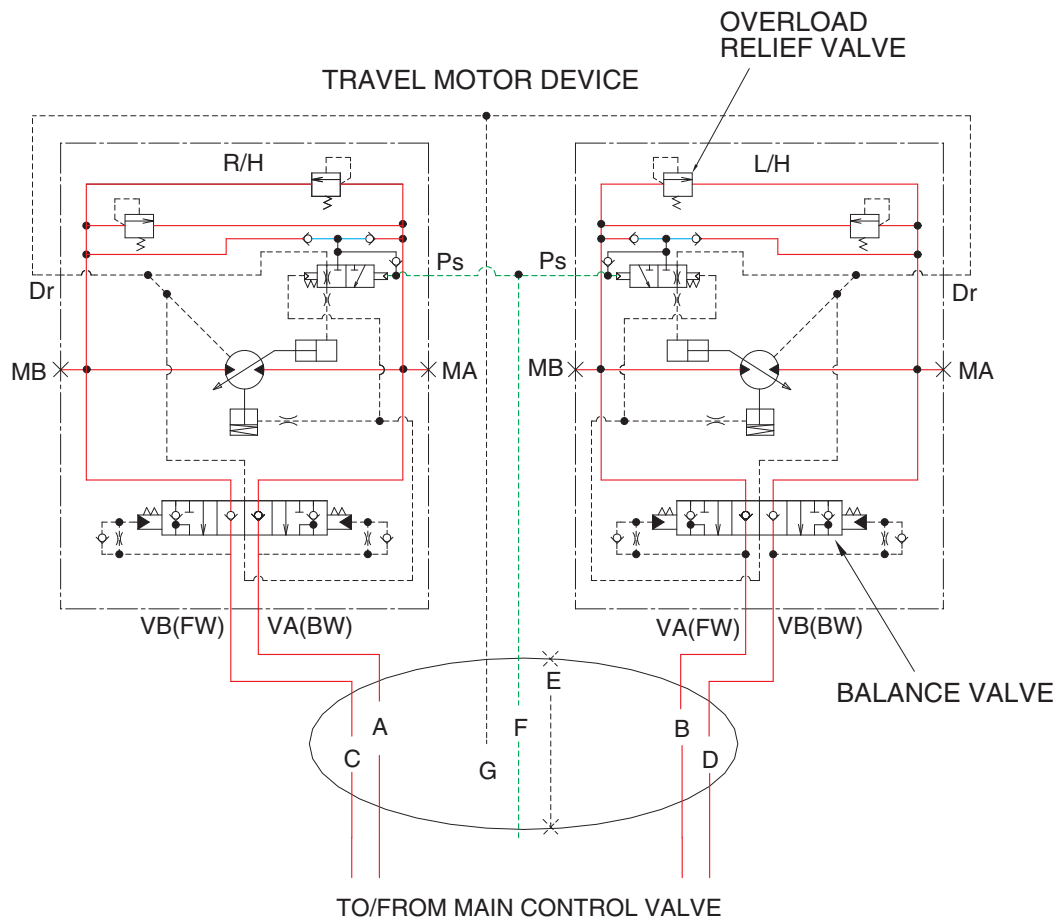

480S3HC19

Valves are provided on travel motors to offer the following functions.

1) COUNTER BALANCE VALVE

When stopping the motor of slope descending, this valve to prevent the motor over run.

2) OVERLOAD RELIEF VALVE

Relief valve limit the circuit pressure below 345 kgf/cm² (4910 psi) to prevent high pressure generated at a time of stopping the machine. Stopping the motor, this valve sucks the oil from lower pressure passage for preventing the negative pressure and the cavitation of the motor.

GROUP 5 COMBINED OPERATION

1. OUTLINE

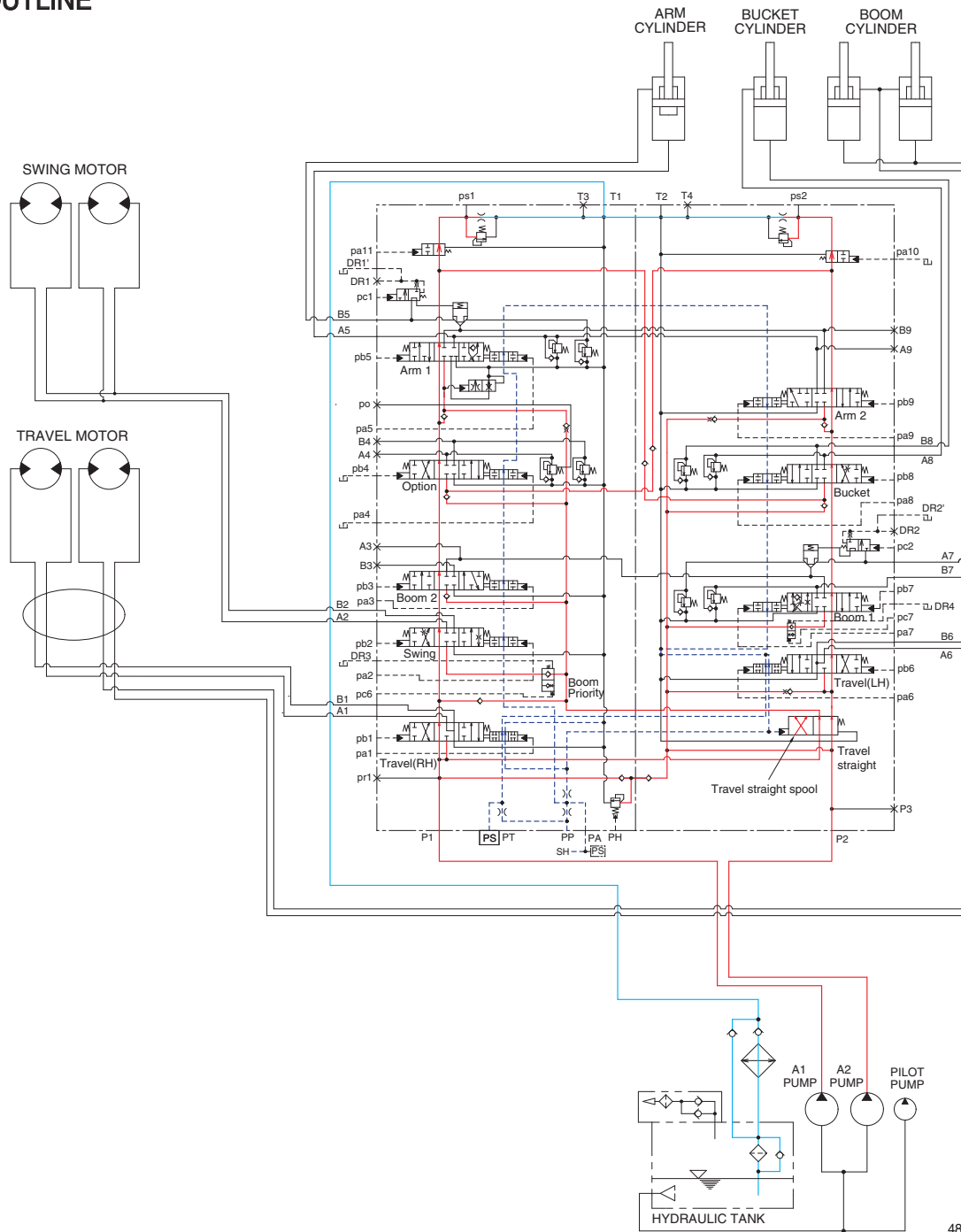

480S3HC20

The oil from the A1 and A2 pump flows through the neutral oil passage, bypass oil passage and confluence oil passage in the main control valve. Then the oil goes to each actuator and operates them. Check valves and orifices are located on these oil passage in the main control valve. These control the oil from the main pumps so as to correspond to the operation of each actuator and smooth the combined operation.

STRAIGHT TRAVEL SPOOL

This straight travel spool is provided in the main control valve.

If any actuator is operated when traveling, the straight travel spool is pushed to the right by the pilot oil pressure from the pilot pump.

Consequently, the left and right travel oil supply passage are connected, and equivalent amount of oil flows into the left and right travel motors. This keeps the straight travel.

2. COMBINED SWING AND BOOM UP OPERATION

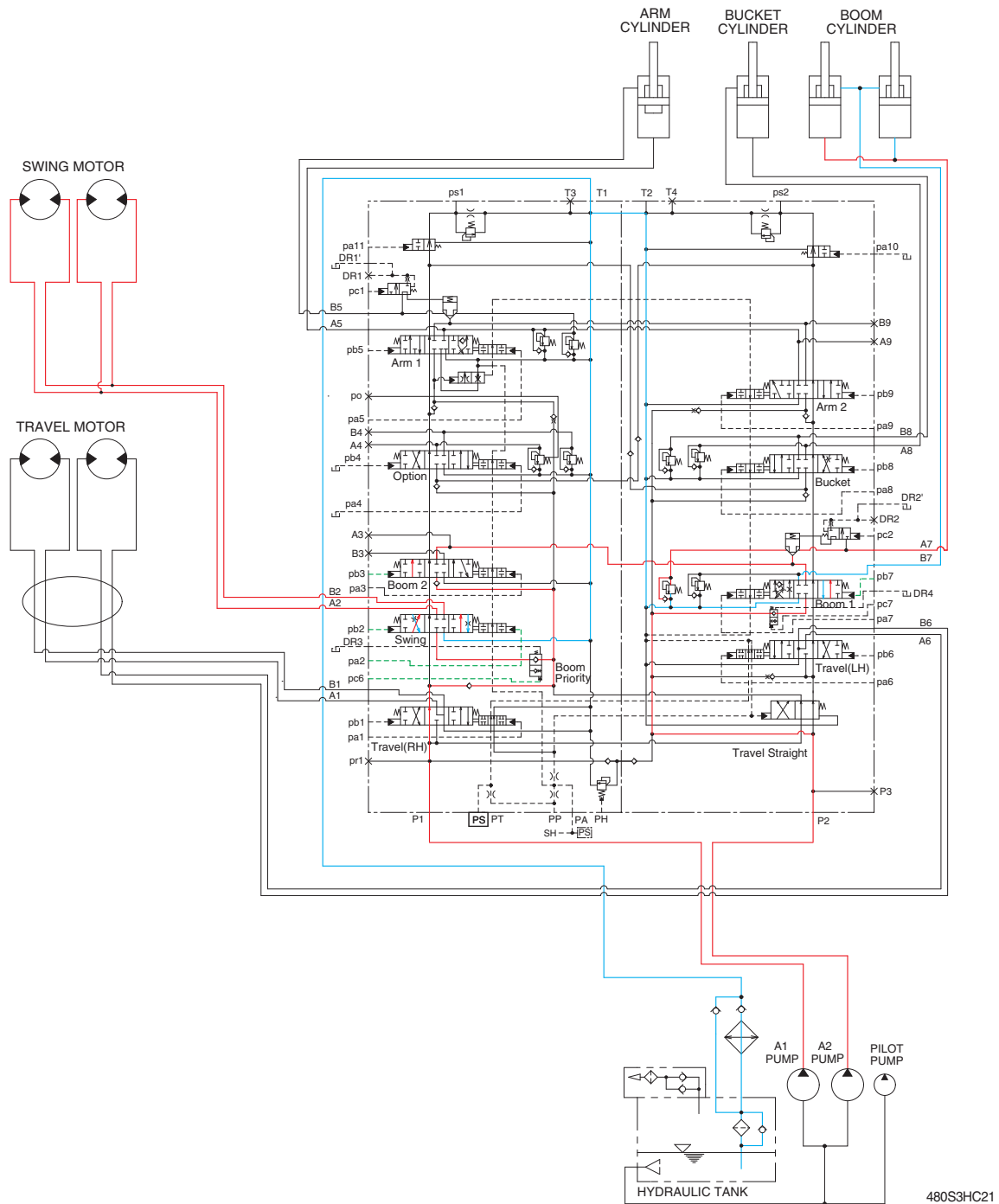

When the swing and boom up functions are operated, simultaneously the swing spool and boom spools in the main control valve are moved to the functional position by the pilot oil pressure from the remote control valve.

The oil from the A1 pump flows into the swing motor through swing spool and the boom cylinder through boom 2 spool.

The oil from the A2 pump flows into the boom cylinders through the boom 1 spool in the right control valve. The upper structure swings and the boom is operated.

Refer to page 3-8 for the boom priority system.

3. COMBINED SWING AND ARM OPERATION

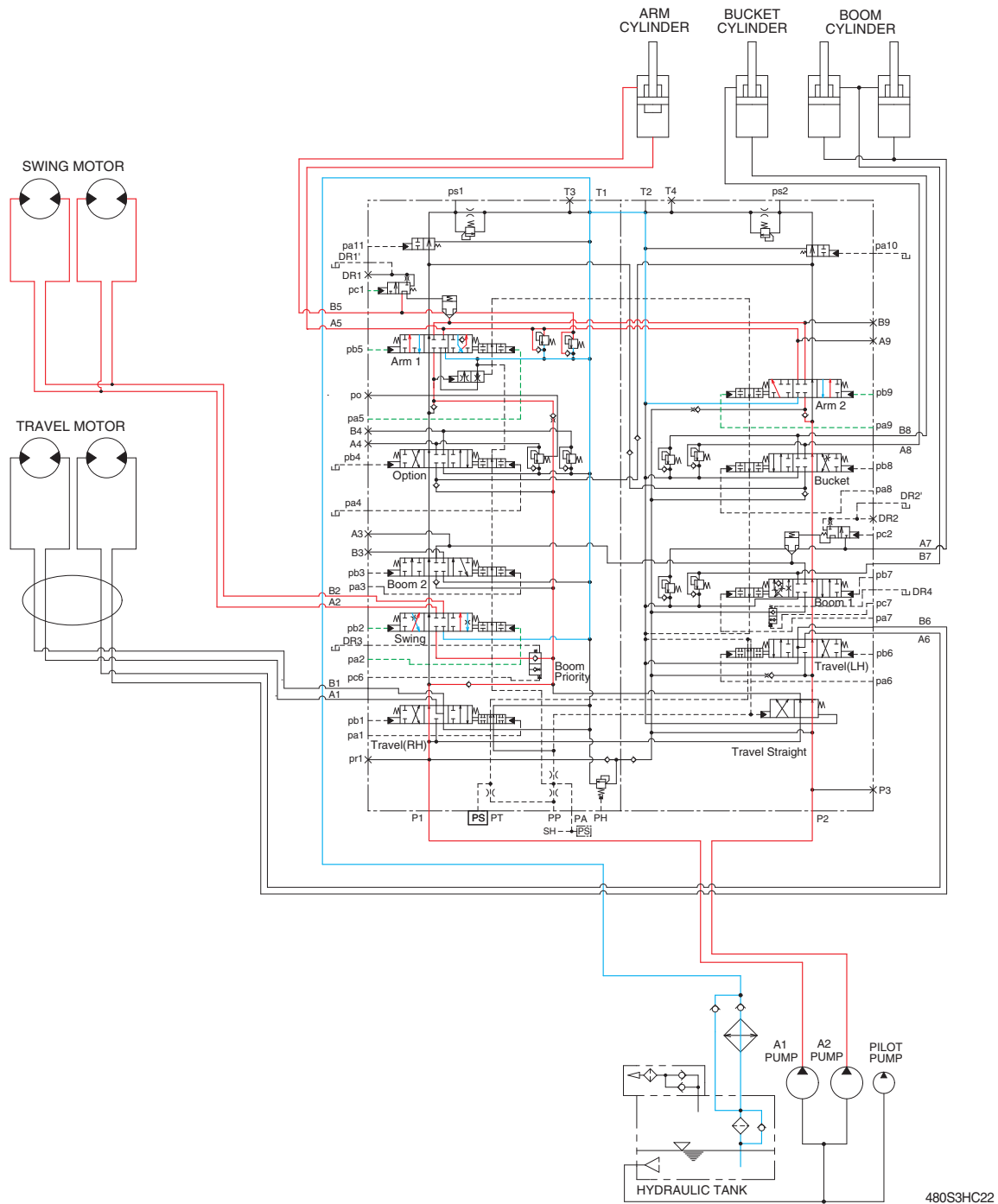

480S3HC22

When the swing and arm functions are operated, simultaneously the swing spool and arm spools in the main control valve are moved to the functional position by the pilot oil pressure from the remote control valve.

The oil from the A1 pump flows into the swing motor through swing spool and the arm cylinder through arm 1 spool.

The oil from the A2 pump flows into the arm cylinder through the arm 2 spool of the right control valve. The upper structure swings and the arm is operated.

Refer to page 2-35 for the swing operation preference function.

4. COMBINED SWING AND BUCKET OPERATION

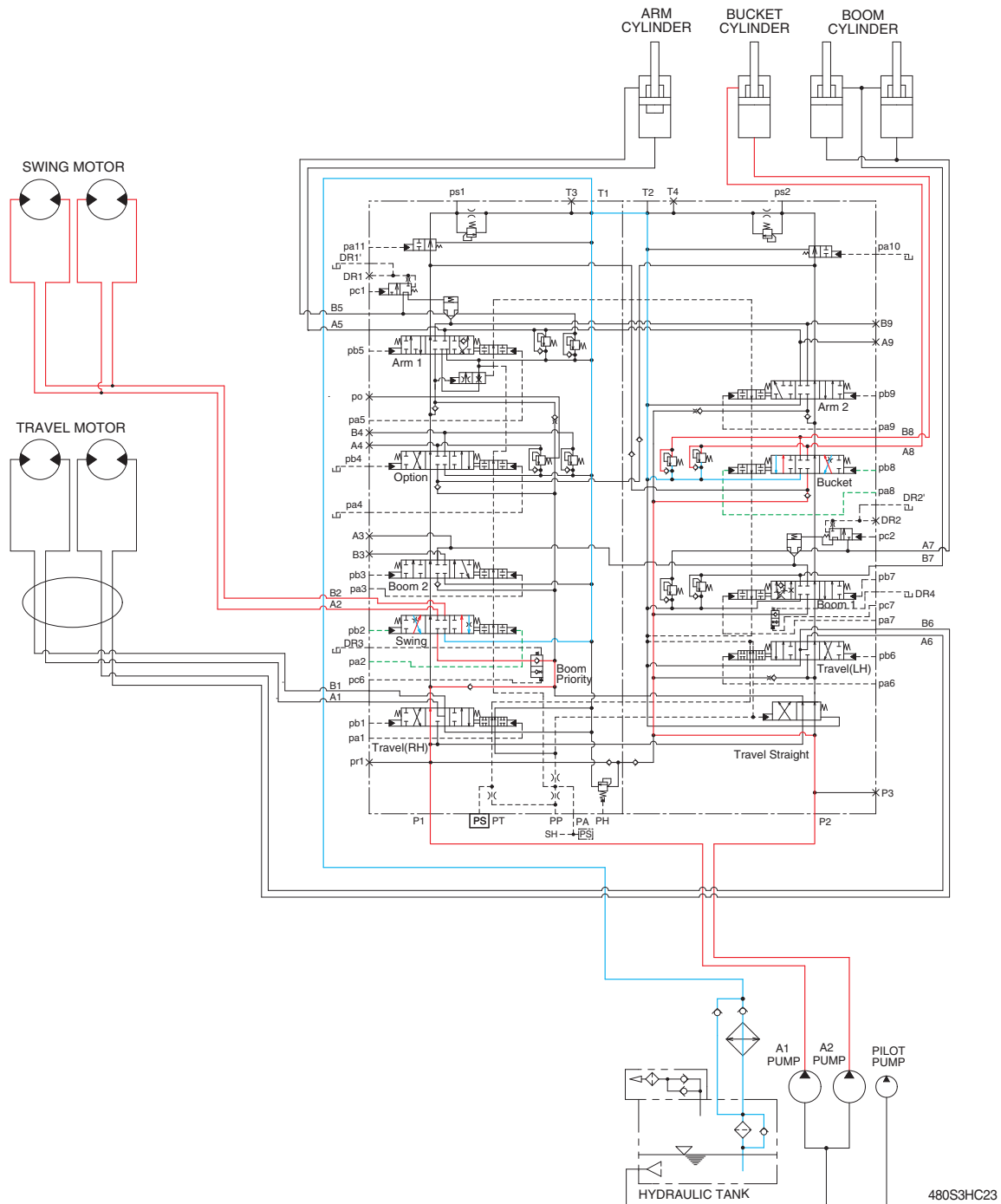

When the swing and bucket functions are operated, simultaneously the swing spool and bucket spool in the main control valve are moved to the functional position by the pilot oil pressure from the remote control valve.

The oil from the A1 pump flows into the swing motor through the swing spool in the left control valve. The oil from the A2 pump flows into the bucket cylinder through the bucket spool in the right control valve.

The upper structure swings and the bucket is operated.

5. COMBINED SWING AND TRAVEL OPERATION

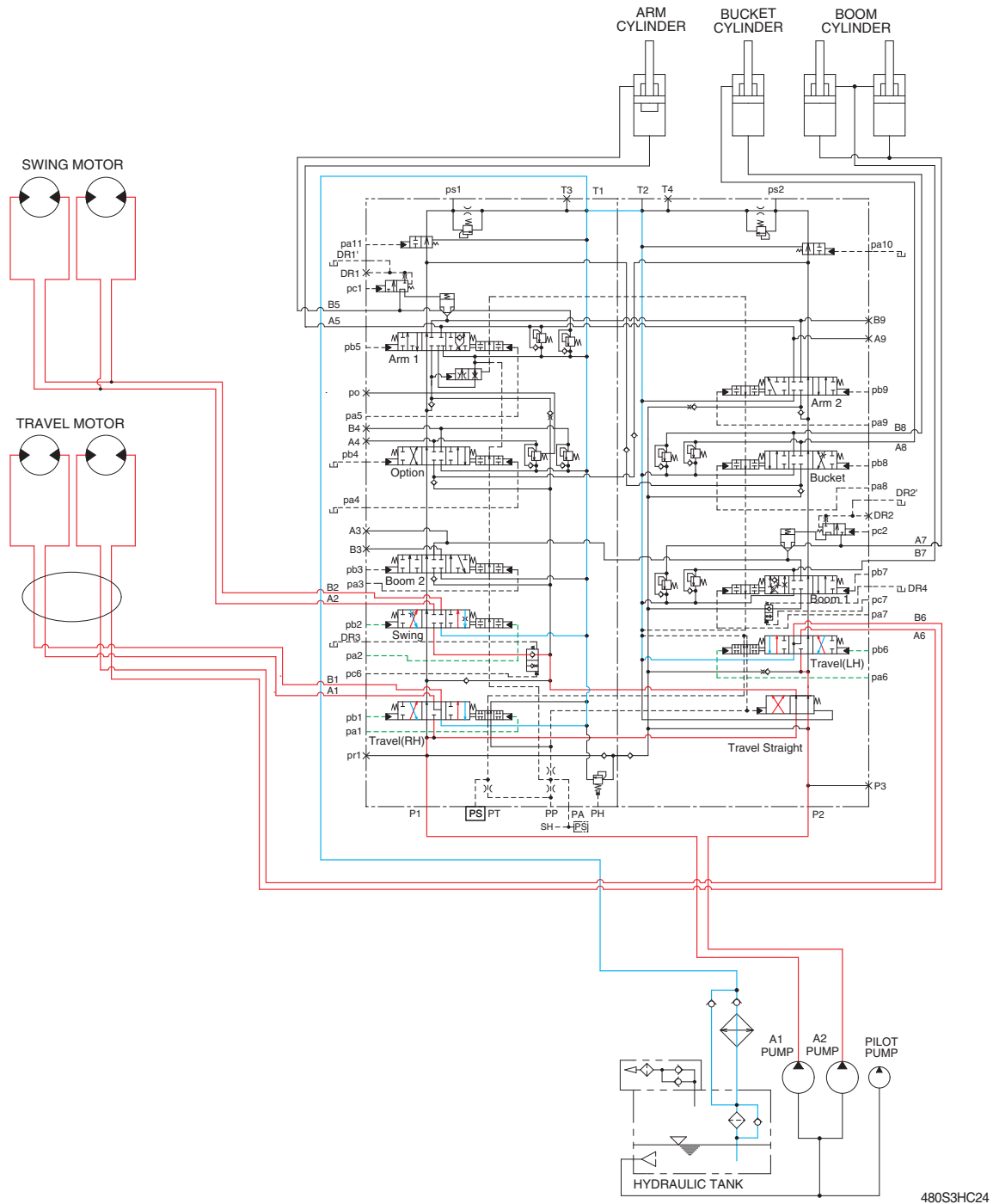

480S3HC24

When the swing and travel functions are operated, simultaneously the swing spool and travel spools in the main control valve are moved to the functional position by the pilot oil pressure from the remote control valve and straight travel spool is pushed to the right by the pilot oil pressure from the pilot pump.

The oil from the A1 pump flows into the travel motors through the RH travel spool of the left control valve and the LH travel spool of the right control valve via the straight travel spool.

The oil from the A2 pump flows into the swing motor through the swing spool.

The upper structure swings and the machine travels straight.

6. COMBINED BOOM AND TRAVEL OPERATION

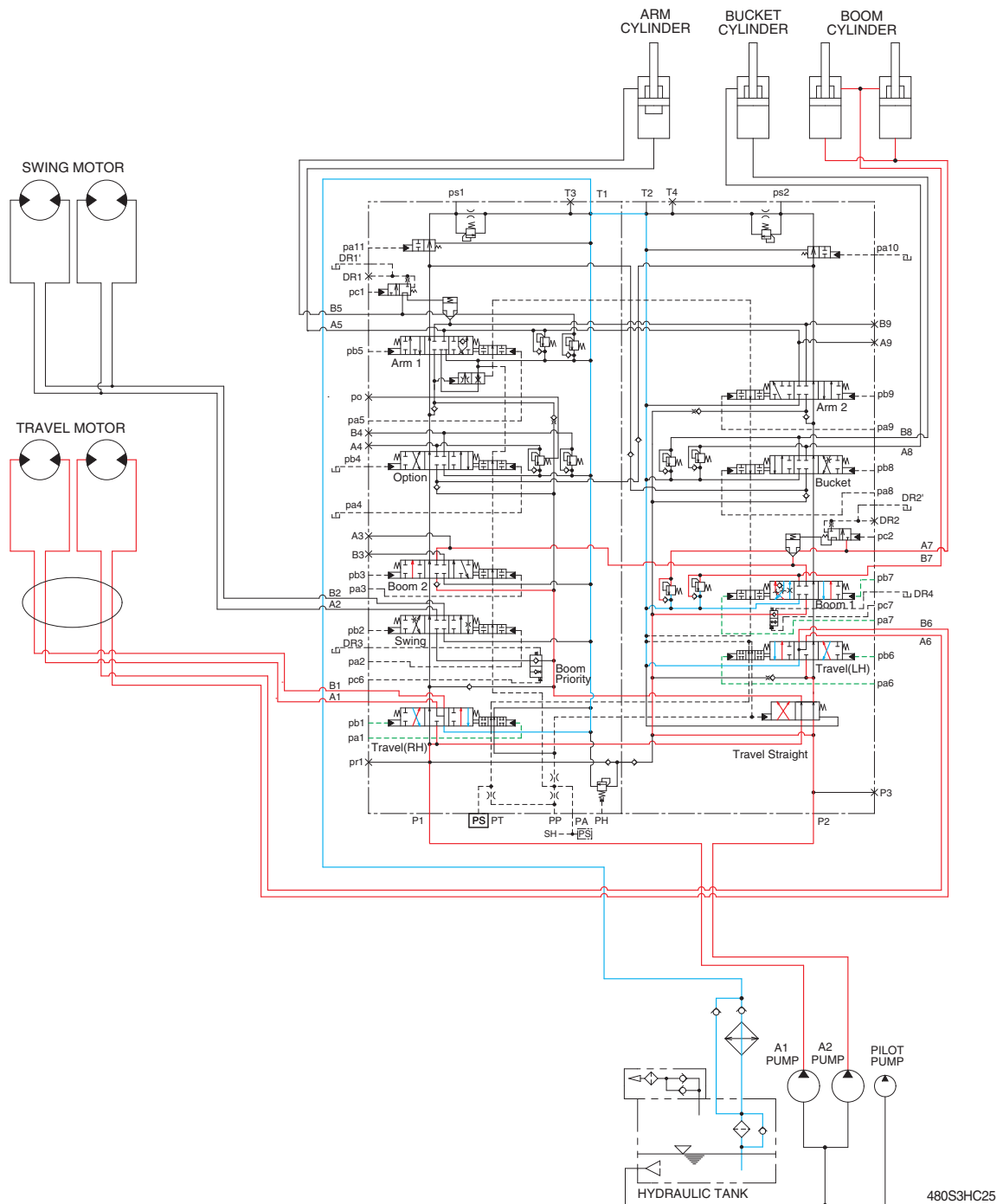

When the boom and travel functions are operated, simultaneously the boom spools and travel spools in the main control valve are moved to the functional position by the pilot oil pressure from the remote control valve and the straight travel spool is pushed to the right by the oil pressure from pilot pump.

The oil from the A1 pump flows into the travel motors through the RH travel spool of the left control valve and the LH travel spool of the right control valve via the straight travel spool.

The oil from the A2 pump flows into the boom cylinders through the boom 2 spool and boom 1 spool via the parallel and confluence oil passage in case boom up operation.

The boom is operated and the machine travels straight.

7. COMBINED ARM AND TRAVEL OPERATION

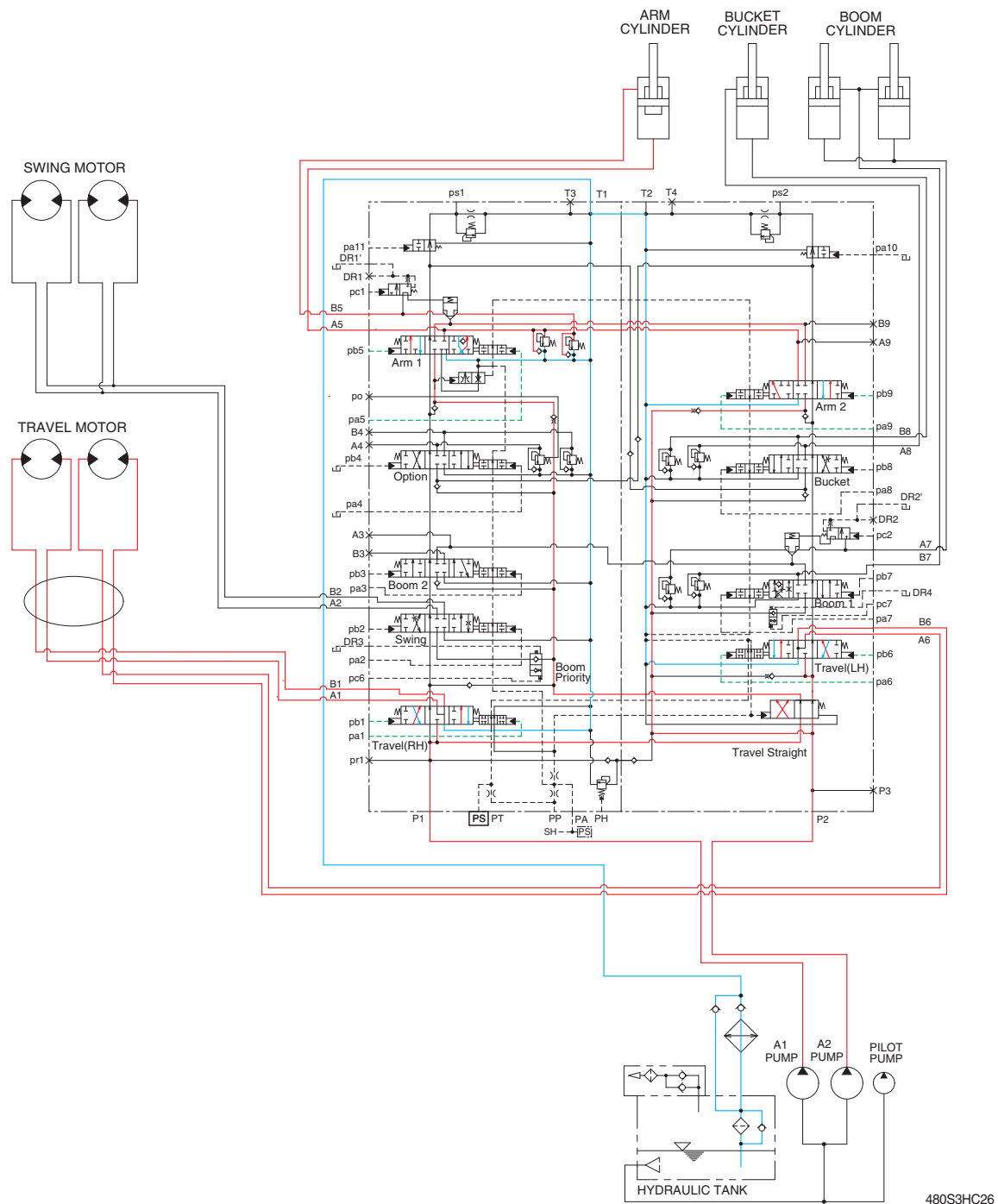

When the arm and travel functions are operated, simultaneously the arm spools and travel spools in the main control valve are moved to the functional position by the pilot oil pressure from the remote control valve and the straight travel spool is pushed to the right by the oil pressure from pilot pump. The oil from the A1 pump flows into the travel motors through the RH travel spool of the left control valve and the LH travel spool of the right control valve via the straight travel spool. The oil from the A2 pump flows into the arm cylinders through the arm 1 spool and arm 2 spool via the parallel and confluence oil passage. The arm is operated and the machine travels straight.

8. COMBINED BUCKET AND TRAVEL OPERATION

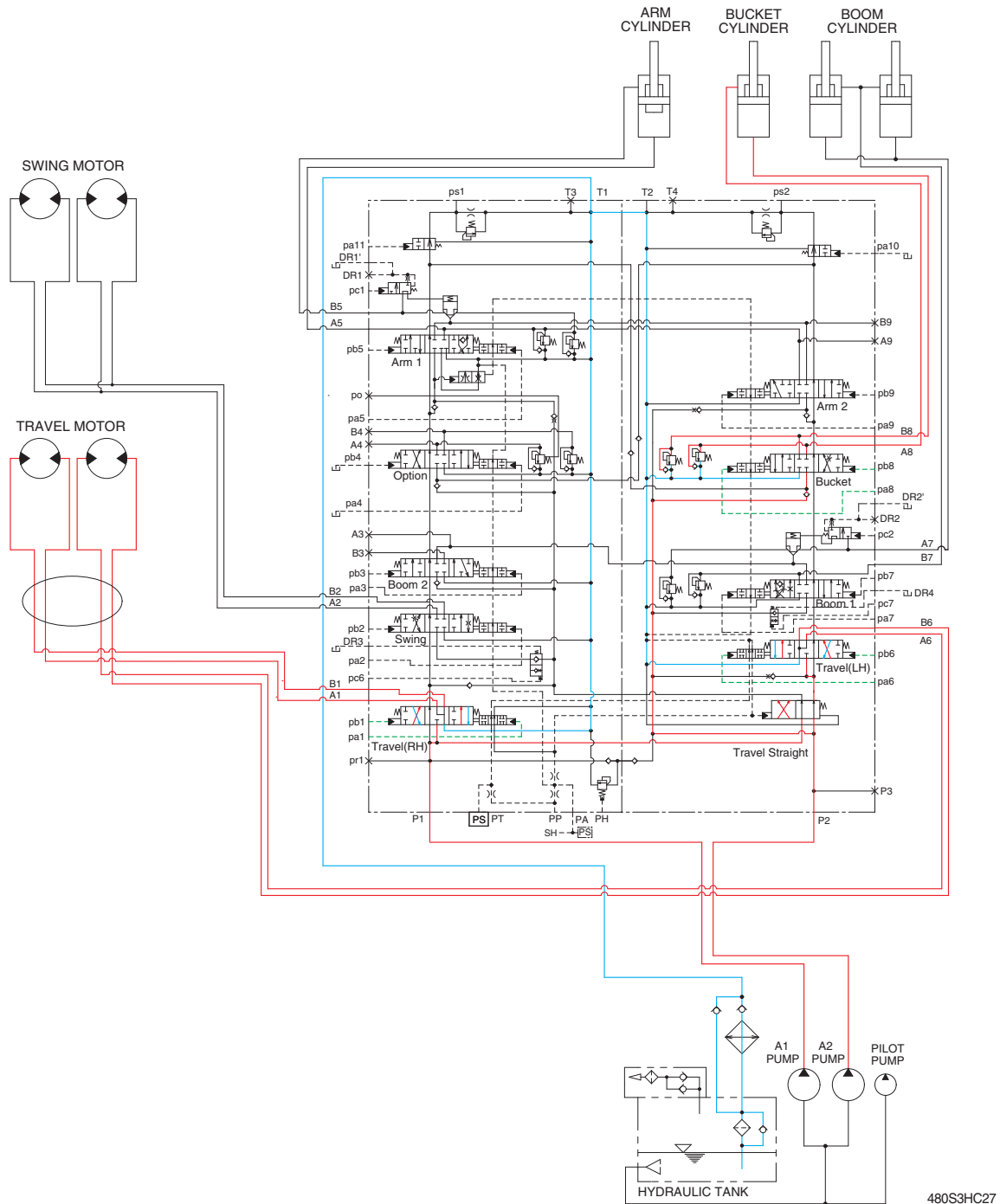

When the bucket and travel functions are operated, simultaneously the bucket spool and travel spools in the main control valve are moved to the functional position by the pilot oil pressure from the remote control valve, and the straight travel spool is pushed to the right by the oil pressure from pilot pump. The oil from the A1 pump flows into the travel motors through the RH travel spool of the left control valve and the LH travel spool of the right control valve via the straight travel spool of the control valve.

The oil from the A2 pump flows into the bucket cylinder through the bucket spool via the confluence oil passage.

The bucket is operated and the machine travels straight.