

SECTION 7 MAINTENANCE STANDARD



- Group 1 Operational Performance Test 7-1
- Group 2 Major Components 7-20
- Group 3 Track and Work Equipment 7-30

SECTION 7 MAINTENANCE STANDARD

GROUP 1 OPERATIONAL PERFORMANCE TEST

1. PURPOSE

Performance tests are used to check :

1) OPERATIONAL PERFORMANCE OF A NEW MACHINE

Whenever a new machine is delivered in parts and reassembled at a customer's site, it must be tested to confirm that the operational performance of the machine meets Hyundai spec.

2) OPERATIONAL PERFORMANCE OF A WORKING MACHINE

With the passage of time, the machine's operational performance deteriorates, so that the machine needs to be serviced periodically to restore it to its original performance level.

Before servicing the machine, conduct performance tests to check the extent of deterioration, and to decide what kind of service needs to be done (by referring to the "Service Limits" in this manual).

3) OPERATIONAL PERFORMANCE OF A REPAIRED MACHINE

After the machine is repaired or serviced, it must be tested to confirm that its operational performance was restored by the repair and/or service work done.

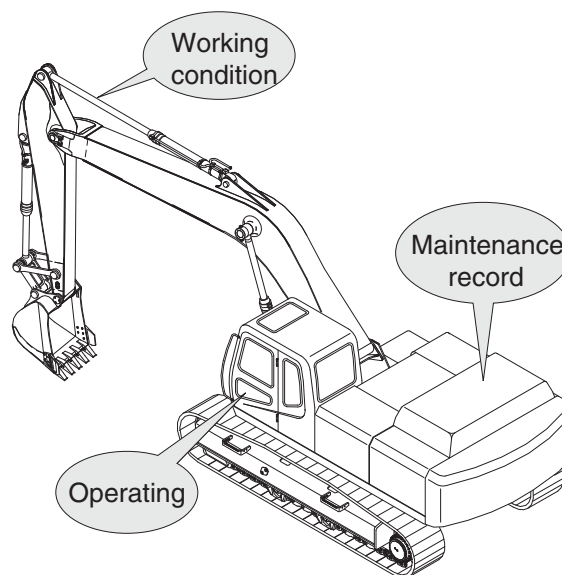

21077MS01

2. TERMINOLOGY

1) STANDARD

Specifications applied to the brand-new machine, components and parts.

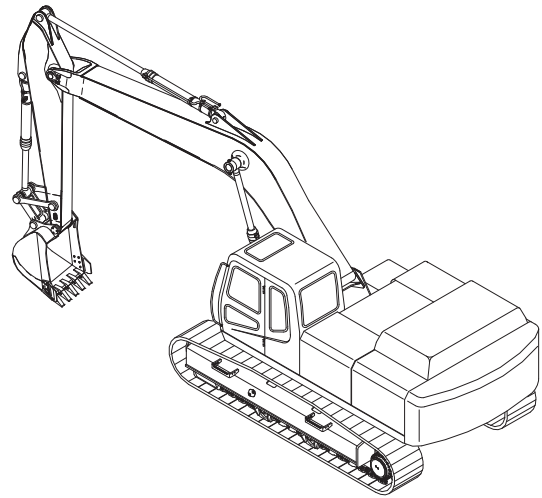

21077MS02

2) SERVICE LIMIT

The lowest acceptable performance level. When the performance level of the machine falls below this level, the machine must be removed from work and repaired. Necessary parts and components must be replaced.

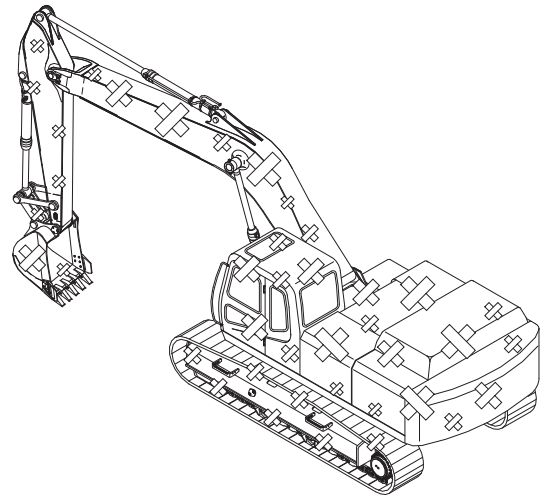

21077MS03

3. OPERATION FOR PERFORMANCE TESTS

- 1) Observe the following rules in order to carry out performance tests accurately and safely.

(1) The machine

Repair any defects and damage found, such as oil or water leaks, loose bolts, cracks and so on, before starting to test.

(2) Test area

- ① Select a hard, flat surface.
- ② Secure enough space to allow the machine to run straight more than 20 m, and to make a full swing with the front attachment extended.
- ③ If required, rope off the test area and provide signboards to keep unauthorized personnel away.

(3) Precautions

- ① Before starting to test, agree upon the signals to be employed for communication among coworkers. Once the test is started, be sure to communicate with each other using these signals, and to follow them without fail.
- ② Operate the machine carefully and always give first priority to safety.
- ③ While testing, always take care to avoid accidents due to landslides or contact with high voltage power lines. Always confirm that there is sufficient space for full swings.
- ④ Avoid polluting the machine and the ground with leaking oil. Use oil pans to catch escaping oil. Pay special attention to this when removing hydraulic pipings.

(4) Make precise measurements

- ① Accurately calibrate test instruments in advance to obtain correct data.
- ② Carry out tests under the exact test conditions prescribed for each test item.
- ③ Repeat the same test and confirm that the test data obtained can be procured repeatedly. Use mean values of measurements if necessary.

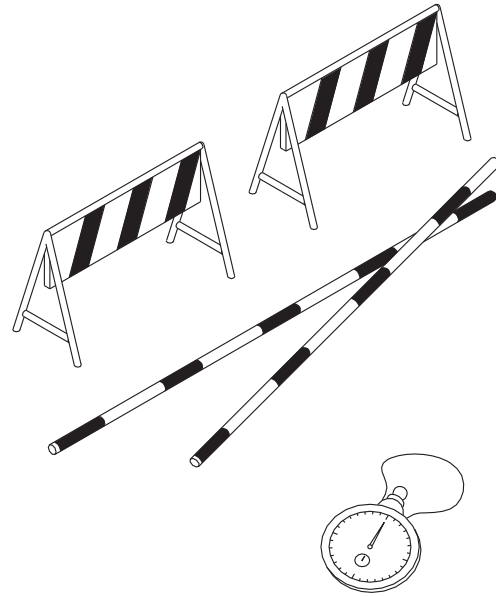

(210-7) 7-3

2) ENGINE SPEED

(1) Measure the engine speed at each power mode

※ The engine speed at each power mode must meet standard RPM; if not, all other operational performance data will be unreliable. It is essential to perform this test first.

(2) Preparation

- ① Warm up the machine, until the engine coolant temperature reaches 50°C or more, and the hydraulic oil is 50 ± 5°C.
- ② Set the accel dial at 10 (Max) position.
- ③ Measure the engine RPM.

(3) Measurement

- ① Start the engine. The engine will run at start idle speed. Measure engine speed with a engine rpm display.
- ② Measure and record the engine speed at each mode (P, S, E).
- ③ Select the P-mode.
- ④ Lightly operate the bucket control lever a few times, then return the control lever to neutral; The engine will automatically enter the auto-idle speed after 4 seconds.
- ⑤ Measure and record the auto deceleration speed.

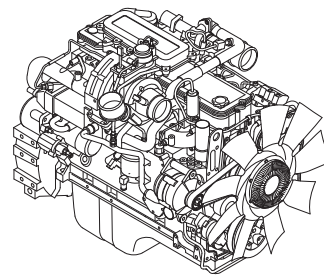

330F7MS01

(4) Evaluation

The measured speeds should meet the following specifications.

Unit : rpm

Model	Engine speed	Standard	Remarks
HX430 L	Start idle	900 ± 100	
	P mode	1750 ± 50	
	S mode	1650 ± 50	
	E mode	1550 ± 50	
	Auto decel	1000 ± 100	
	One touch decel	900 ± 100	

Condition : Set the accel dial at 10 (Max) position.

3) TRAVEL SPEED

(1) Measure the time required for the excavator to travel a 20 m test track.

(2) Preparation

- ① Adjust the tension of both tracks to be equal.
- ② Prepare a flat and solid test track 20m in length, with extra length of 3 to 5 m on both ends for machine acceleration and deceleration.
- ③ Hold the bucket 0.3 to 0.5 m above the ground with the arm and bucket rolled in.
- ④ Keep the hydraulic oil temperature at $50 \pm 5^\circ\text{C}$.

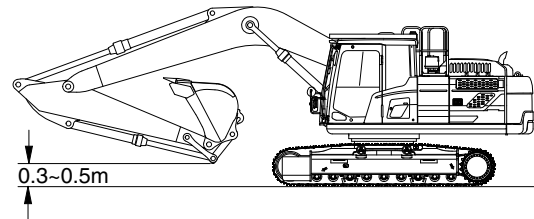

260A7MS02

(3) Measurement

- ① Measure both the low and high speeds of the machine.
- ② Before starting either the low or high speed tests, adjust the travel mode switch to the speed to be tested, then select the following switch positions.
 - Power mode switch : P mode
- ③ Start traveling the machine in the acceleration zone with the travel levers at full stroke.
- ④ Measure the time required to travel 20 m.
- ⑤ After measuring the forward travel speed, turn the upperstructure 180° and measure the reverse travel speed.
- ⑥ Repeat steps ④ and ⑤ three times in each direction and calculate the average values.

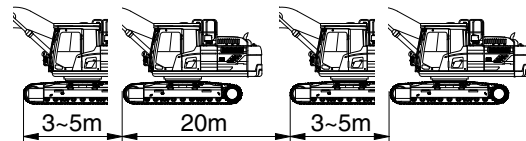

260A7MS03

(4) Evaluation

The average measured time should meet the following specifications.

Unit : Seconds / 20 m

Model	Travel speed	Standard	Maximum allowable	Remarks
HX430 L	1 Speed	22.9 ± 2.0	27.0	
	2 Speed	13.0 ± 1.0	15.0	

4) TRACK REVOLUTION SPEED

(1) Measure the track revolution cycle time with the track raised off ground.

(2) Preparation

- ① Adjust the tension of both side tracks to be equal.
- ② On the track to be measured, mark one shoe with chalk.
- ③ Swing the upperstructure 90° and lower the bucket to raise the track off ground. Keep the boom-arm angle between 90 to 110° as shown. Place blocks under machine frame.
- ④ Keep the hydraulic oil temperature at $50 \pm 5^\circ\text{C}$.

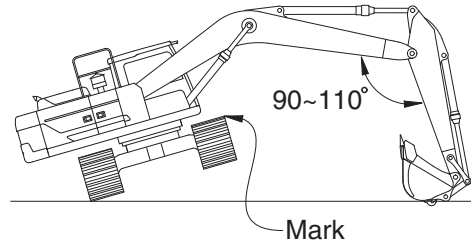

300L7MS04

(3) Measurement

- ① Select the following switch positions.
 - Travel mode switch : 1 or 2 speed
 - Power mode switch : P mode
 - Auto idle switch : OFF
- ② Operate the travel control lever of the raised track in full forward and reverse.
- ③ Rotate 1 turn, then measure time taken for next 3 revolutions.
- ④ Raise the other side of machine and repeat the procedure.
- ⑤ Repeat steps ③ and ④ three times and calculate the average values.

(4) Evaluation

The revolution cycle time of each track should meet the following specifications.

Unit : Seconds / 3 revolutions

Model	Travel speed	Standard	Maximum allowable
HX430 L	1 Speed	38.6 ± 2.0	48.1
	2 Speed	22.9 ± 2.0	22.9

5) TRAVEL DEVIATION

(1) Measure the deviation by the tracks from a 20 m straight line.

(2) Preparation

- ① Adjust the tension of both tracks to be equal.
- ② Provide a flat, solid test yard 20 m in length, with extra length of 3 to 5 m on both ends for machine acceleration and deceleration.
- ③ Hold the bucket 0.3 to 0.5 m above the ground with the arm and bucket rolled in.
- ④ Keep the hydraulic oil temperature at $50 \pm 5^\circ\text{C}$.

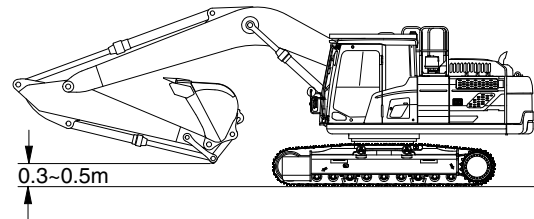

260A7MS02

(3) Measurement

- ① Measure the amount of mistracking at high and low travel speeds.
- ② Before beginning each test, select the following switch positions.
 - Power mode switch : P mode
- ③ Start traveling the machine in the acceleration zone with the travel levers at full stroke.
- ④ Measure the distance between a straight 20 m line and the track made by the machine. (Dimension a)
- ⑤ After measuring the tracking in forward travel, turn the upperstructure 180° and measure that in reverse travel.
- ⑥ Repeat steps ④ and ⑤ three times and calculate the average values.

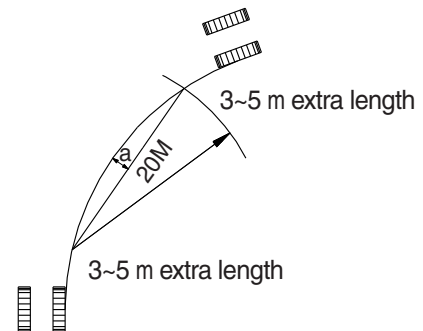

(210-7) 7-7(2)

(4) Evaluation

Mistrack should be within the following specifications.

Unit : mm / 20 m

Model	Standard	Maximum allowable	Remarks
HX430 L	200 below	250	-

6) SWING SPEED

- (1) Measure the time required to swing three complete turns.

(2) Preparation

- ① Check the lubrication of the swing gear and swing bearing.
- ② Place the machine on flat, solid ground with ample space for swinging. Do not conduct this test on slopes.
- ③ With the arm rolled out and bucket rolled in, hold the bucket so that the height of the bucket pin is the same as the boom foot pin. The bucket must be empty.
- ④ Keep the hydraulic oil temperature at $50 \pm 5^\circ\text{C}$.

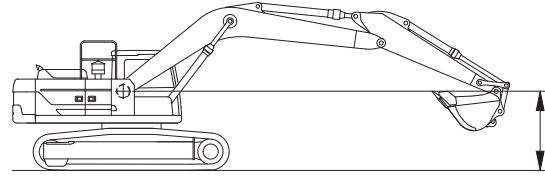

300L7MS05

(3) Measurement

- ① Select the following switch positions.
 - Power mode switch : P mode
- ② Operate swing control lever fully.
- ③ Swing 1 turn and measure time taken to swing next 3 revolutions.
- ④ Repeat steps ② and ③ three time and calculate the average values.

(4) Evaluation

The time required for 3 swings should meet the following specifications.

Unit : Seconds / 3 revolutions

Model	Power mode switch	Standard	Maximum allowable
HX430 L	P mode	19.6 ± 1.5	24.5

7) SWING FUNCTION DRIFT CHECK

- (1) Measure the swing drift on the bearing outer circumference when stopping after a 360° full speed swing.

(2) Preparation

- ① Check the lubrication of the swing gear and swing bearing.
- ② Place the machine on flat, solid ground with ample space for swinging. Do not conduct this test on slopes.
- ③ With the arm rolled out and bucket rolled in, hold the bucket so that the height of the bucket pin is the same as the boom foot pin. The bucket must be empty.
- ④ Make two chalk marks: one on the swing bearing and one directly below it on the track frame.
- ⑤ Swing the upperstructure 360°.
- ⑥ Keep the hydraulic oil temperature at $50 \pm 5^\circ\text{C}$.

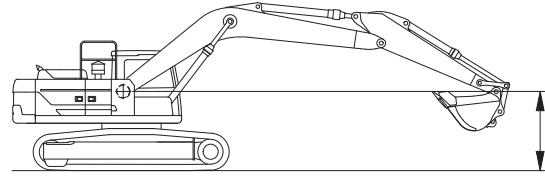

300L7MS05

(3) Measurement

- ① Conduct this test in the M mode.
- ② Select the following switch positions.
 - Power mode switch : P mode
- ③ Operate the swing control lever fully and return it to the neutral position when the mark on the upperstructure aligns with that on track frame after swinging 360°
- ④ Measure the distance between the two marks.
- ⑤ Align the marks again, swing 360° , then test the opposite direction.
- ⑥ Repeat steps ④ and ⑤ three times each and calculate the average values.

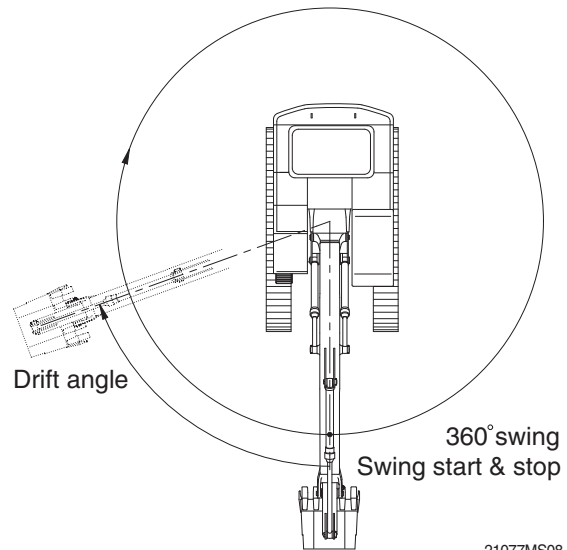

21077MS08

(4) Evaluation

The measured drift angle should be within the following specifications.

Unit : Degree

Model	Power mode switch	Standard	Maximum allowable	Remarks
HX430 L	P mode	90 below	112.5	

8) SWING BEARING PLAY

- (1) Measure the swing bearing play using a dial gauge to check the wear of bearing races and balls.

(2) Preparation

- ① Check swing bearing mounting cap screws for loosening.
- ② Check the lubrication of the swing bearing. Confirm that bearing rotation is smooth and without noise.
- ③ Install a dial gauge on the track frame as shown, using a magnetic base.
- ④ Position the upperstructure so that the boom aligns with the tracks facing towards the front idlers.
- ⑤ Position the dial gauge so that its needle point comes into contact with the bottom face of the bearing outer race.
- ⑥ Bucket should be empty.

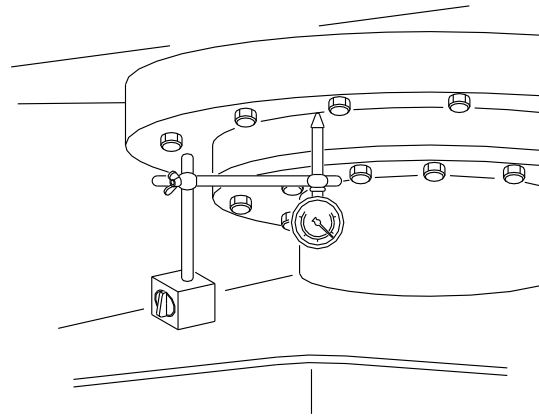

(210-7) 7-10(1)

(3) Measurement

- ① With the arm rolled out and bucket rolled in, hold the bottom face of the bucket to the same height of the boom foot pin. Record the dial gauge reading (h1).
- ② Lower the bucket to the ground and use it to raise the front idler 50 cm. Record the dial gauge reading (h2).
- ③ Calculate bearing play (H) from this data (h1 and h2) as follows.
 $H = h2 - h1$

Measurement : (h1)

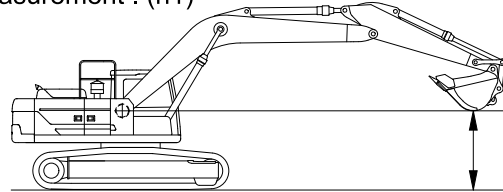

Measurement : (h2)

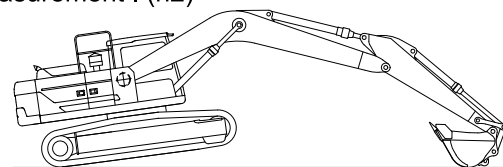

300L7MS06

(4) Evaluation

The measured drift should be within the following specifications.

Unit : mm

Model	Standard	Maximum allowable	Remarks
HX430 L	0.5 ~ 1.5	3.0	

9) HYDRAULIC CYLINDER CYCLE TIME

- (1) Measure the cycle time of the boom, standard arm, and standard bucket cylinders.

(2) Preparation

- ① To measure the cycle time of the boom cylinders:

With the arm rolled out and the empty bucket rolled out, lower the bucket to the ground, as shown.

- ② To measure the cycle time of the arm cylinder.

With the empty bucket rolled in, position the arm so that it is vertical to the ground. Lower the boom until the bucket is 0.5 m above the ground.

- ③ To measure the cycle time of the bucket cylinder.

The empty bucket should be positioned at midstroke between roll-in and roll-out, so that the sideplate edges are vertical to the ground.

- ④ Keep the hydraulic oil temperature at $50 \pm 5^\circ\text{C}$.

(3) Measurement

- ① Select the following switch positions.

- Power mode switch : P mode

- ② To measure cylinder cycle times.

- Boom cylinders.

Measure the time it takes to raise the boom, and the time it takes to lower the boom. To do so, position the boom at one stroke end then move the control lever to the other stroke end as quickly as possible.

- Arm cylinder.

Measure the time it takes to roll in the arm, and the time it takes to roll out the arm. To do so, position the bucket at one stroke end, then move the control lever to the other stroke end as quickly as possible.

Boom cylinder

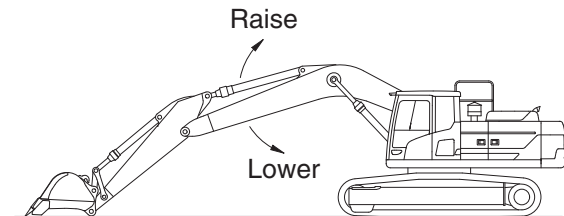

Arm cylinder

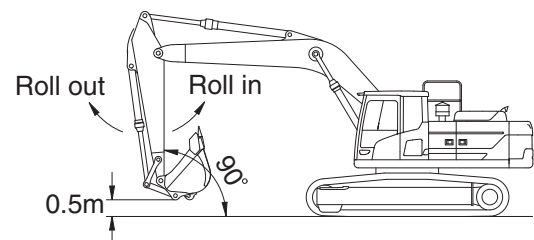

Bucket cylinder

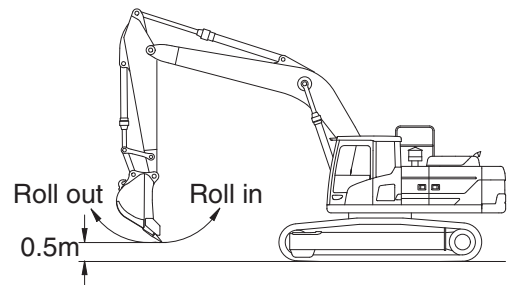

300L7MS07

- Bucket cylinders
Measure the time it takes to roll in the bucket, and the time it takes to roll out the bucket. To do so, position the bucket at one stroke end, then move the control lever to the other stroke end as quickly as possible.
- Repeat each measurement 3 times and calculate the average values.

(4) Evaluation

The average measured time should meet the following specifications.

Unit : Seconds

Model	Function	Standard	Maximum allowable	Remarks
HX430 L	Boom raise	4.0±0.4	4.9	
	Boom lower	2.7±0.4	3.8	
	Arm in	3.1±0.4	3.8	
	Arm out	2.9±0.3	3.2	
	Bucket load	2.7±0.4	3.5	
	Bucket dump	2.4±0.3	3.5	

10) DIG FUNCTION DRIFT CHECK

- (1) Measure dig function drift, which can be caused by oil leakage in the control valve and boom, standard arm, and standard bucket cylinders, with the loaded bucket. When testing the dig function drift just after cylinder replacement, slowly operate each cylinder to its stroke end to purge air.

(2) Preparation

- ① Load bucket fully. Instead of loading the bucket, weight(W) of the following specification can be used.
 - $W = M^3 \times 1.5$
 - Where :
 - M^3 = Bucket heaped capacity (m^3)
 - 1.5 = Soil specific gravity
- ② Position the arm cylinder with the rod 20 to 30 mm extended from the fully retracted position.
- ③ Position the bucket cylinder with the rod 20 to 30 mm retracted from the fully extended position.
- ④ With the arm rolled out and bucket rolled in, hold the bucket so that the height of the bucket pin is the same as the boom foot pin.
- ⑤ Keep the hydraulic oil temperature at $50 \pm 5^\circ C$.

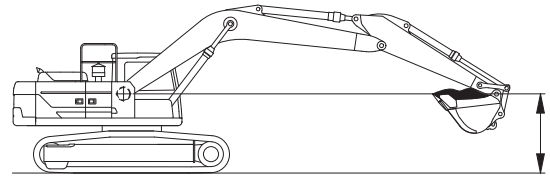

300L7MS08

(3) Measurement

- ① Stop the engine.
- ② Five minutes after the engine has been stopped, measure the changes in the positions of the boom, arm and bucket cylinders.
- ③ Repeat step ② three times and calculate the average values.

- (4) The measured drift should be within the following specifications.

Unit : mm / 5min

Model	Drift to be measured	Standard	Maximum allowable	Remarks
HX430 L	Boom cylinder	10 below	15	
	Arm cylinder	10 below	15	
	Bucket cylinder	40 below	50	

11) CONTROL LEVER OPERATING FORCE

(1) Use a spring scale to measure the maximum resistance of each control lever at the middle of the grip.

(2) Preparation

- ① Keep the hydraulic oil temperature at $50 \pm 5^{\circ}\text{C}$.

(3) Measurement

- ① Start the engine.
- ② Select the following switch positions.
 - Power mode switch : P mode
- ③ Operate each boom, arm, bucket and swing lever at full stroke and measure the maximum operating force for each.
- ④ Lower the bucket to the ground to raise one track off the ground. Operate the travel lever at full stroke and measure the maximum operating force required. When finished, lower the track and then jack-up the other track.
- ⑤ Repeat steps ③ and ④ three times and calculate the average values.

(4) Evaluation

The measured operating force should be within the following specifications.

Unit : kgf

Model	Kind of lever	Standard	Maximum allowable	Remarks
HX430 L	Boom lever	1.3 or below	1.7	
	Arm lever	1.3 or below	1.7	
	Bucket lever	1.3 or below	1.7	
	Swing lever	1.3 or below	1.7	
	Travel lever	2.1 or below	3.15	

12) CONTROL LEVER STROKE

(1) Measure each lever stroke at the lever top using a ruler.

※ When the lever has play, take a half of this value and add it to the measured stroke.

(2) Preparation

Keep the hydraulic oil temperature at $50 \pm 5^{\circ}\text{C}$.

(3) Measurement

- ① Stop the engine.
- ② Measure each lever stroke at the lever top from neutral to the stroke end using a ruler.
- ③ Repeat step ② three times and calculate the average values.

(4) Evaluation

The measured drift should be within the following specifications.

Unit : mm

Model	Kind of lever	Standard	Maximum allowable	Remarks
HX430 L	Boom lever	90 ± 10	115	
	Arm lever	90 ± 10	115	
	Bucket lever	90 ± 10	115	
	Swing lever	90 ± 10	115	
	Travel lever	142 ± 10	178	

13) FOR TRAVEL SPEED SELECTING PRESSURE:

(1) Preparation

- ① Stop the engine.
- ② Loosen the cap and relieve the pressure in the tank by pushing the top of the air breather.
- ③ To measure the speed selecting pressure: Install a connector and pressure gauge assembly to turning joint P port as shown.
- ④ Start the engine and check for on leakage from the adapter.
- ⑤ Keep the hydraulic oil temperature at $50 \pm 5^{\circ}\text{C}$.

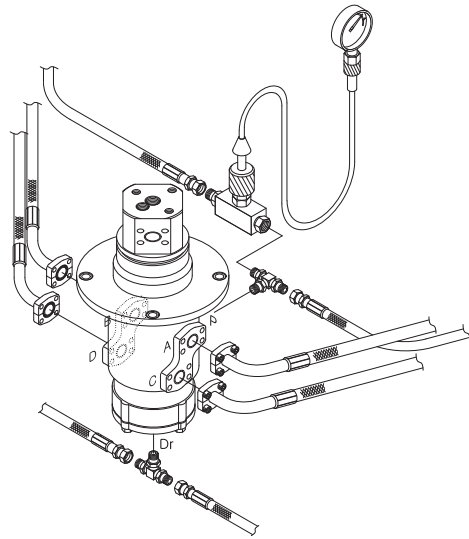

21077MS13

(2) Measurement

- ① Select the following switch positions.
 - Power mode switch : P mode
 - Travel mode switch : 1 speed
2 speed
- ② Measure the travel speed selecting pressure in the Hi or Lo mode.
- ③ Lower the bucket to the ground to raise the track off the ground. Operate the travel lever at full stroke and measure the fast speed pressure.
- ④ Repeat steps ② and ③ three times and calculate the average values.

(3) Evaluation

The average measured pressure should be within the following specifications.

Unit : kgf / cm²

Model	Travel speed mode	Standard	Maximum allowable	Remarks
HX430 L	1 Speed	0	-	
	2 Speed	40 ± 5	-	

14) SWING PARKING BRAKE RELEASING PRESSURE

(1) Preparation

- ① Stop the engine.
- ② Loosen the cap and relieve the pressure in the tank by pushing the top of the air breather.
- ③ The pressure release L wrench to bleed air.
- ④ Install a connector and pressure gauge assembly to swing motor SH port, as shown.
- ⑤ Start the engine and check for oil leakage from the adapter.
- ⑥ Keep the hydraulic oil temperature at $50 \pm 5^{\circ}\text{C}$.

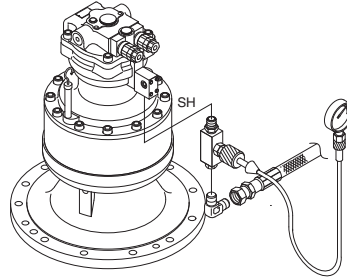

32097MS02

(2) Measurement

- ① Select the following switch positions.
 - Power mode switch : P mode
- ② Operate the swing function or arm roll in function and measure the swing brake control pressure with the brake disengaged. Release the control lever to return to neutral and measure the control pressure when the brake is applied. Repeat step ② three times and calculate the average values.

(3) Evaluation

The average measured pressure should be within the following specifications.

Unit : kgf / cm²

Model	Description	Standard	Allowable limits	Remarks
HX430 L	Brake disengaged	40	31~49	
	Brake applied	0	-	

15) MAIN PUMP DELIVERY PRESSURE

(1) Preparation

- ① Keep the hydraulic oil temperature at $50 \pm 5^\circ\text{C}$.

(2) Measurement

- ① Select the following switch positions.
 - Power mode switch : P mode
- ② Measure the main pump delivery pressure in the P mode (high idle).

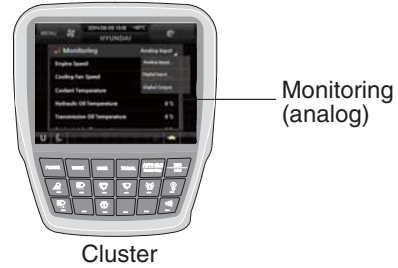
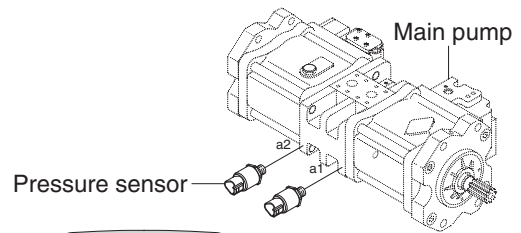

330L7MS03

(3) Evaluation

The average measured pressure should meet the following specifications.

Unit : kgf / cm²

Model	Engine speed	Standard	Allowable limits	Remarks
HX430 L	High idle	40 ± 5	-	

16) SYSTEM PRESSURE REGULATOR RELIEF SETTING

(1) Preparation

- ① Keep the hydraulic oil temperature at $50 \pm 5^{\circ}\text{C}$.

(2) Measurement

- ① Select the following switch positions.
 - Power mode switch : P mode
- ② Slowly operate each control lever of boom, arm and bucket functions at full stroke over relief and measure the pressure.
- ③ In the swing function, place bucket against an immovable object and measure the relief pressure.
- ④ In the travel function, lock undercarriage with an immovable object and measure the relief pressure.

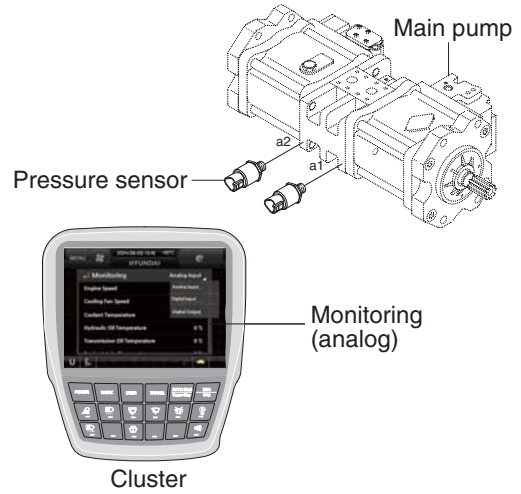

330L7MS03

(3) Evaluation

The average measured pressure should be within the following specifications.

Unit : kgf / cm²

Model	Function to be tested	Standard	Port relief setting
HX430 L	Boom, Arm, Bucket	330 (360) \pm 10	390 \pm 10
	Travel	360 \pm 10	-
	Swing	290 \pm 10	-

() : Power boost

GROUP 2 MAJOR COMPONENT

1. MAIN PUMP

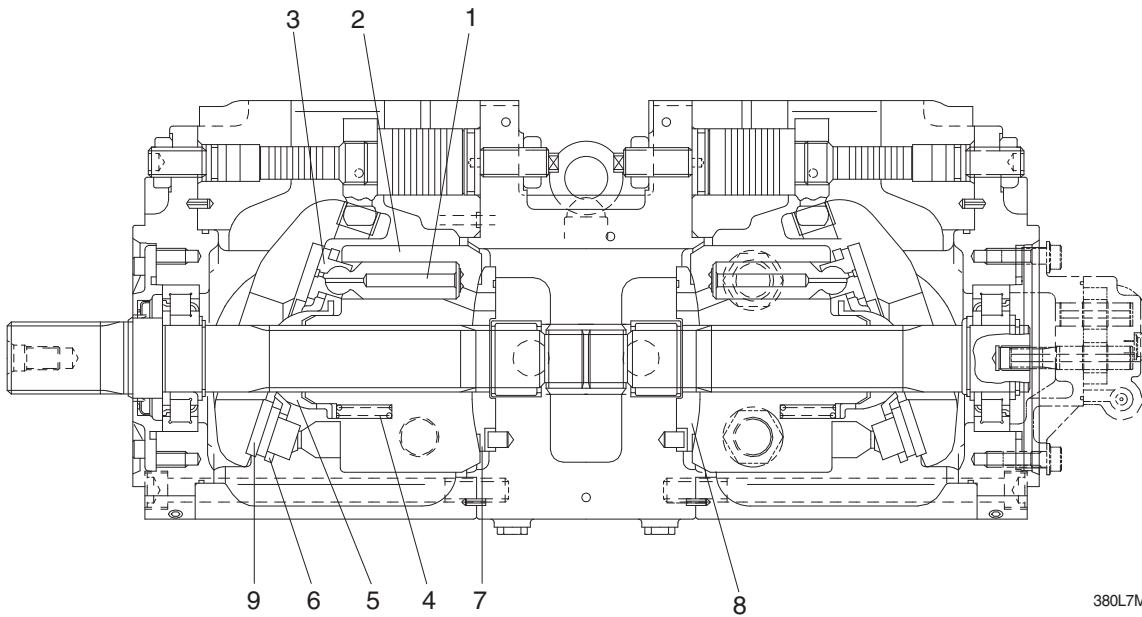

Part name & inspection item		Standard dimension	Recommended replacement value	Counter measures
Clearance between piston(1) & cylinder bore(2) (D-d)		0.043	0.070	Replace piston or cylinder.
Play between piston(1) & shoe caulking section(3) (δ)		0-0.1	0.3	Replace assembly of piston & shoe.
Thickness of shoe (t)		5.4	5.0	
Free height of cylinder spring(4) (L)		47.9	47.1	Replace cylinder spring.
Combined height of set plate(5) & spherical bushing(6) (H-h)		23.8	22.8	Replace retainer or set plate.
Surface roughness for valve plate (sliding face) (7,8), swash plate (shoe plate area) (9), & cylinder(2) (sliding face)	Surface roughness necessary to be corrected	3z		Lapping
	Standard surface roughness (corrected value)	0.4z or lower		

2. MAIN CONTROL VALVE

Part name	Inspection item	Criteria & measure
Casing	<ul style="list-style-type: none"> · Existence of scratches, rust or corrosion. 	<ul style="list-style-type: none"> · In case of damage in following section, replace casing. - Sliding sections of casing hole and spool, especially land sections applied with held pressure. - Seal pocket section where spool is inserted. - Sealing section of port where O-ring contacts. - Sealing section of each relief valve for main and port. - Sealing section of plug. - Other damages that may damage normal function.
Spool	<ul style="list-style-type: none"> · Existence of scratch, gnawing, rusting or corrosion. · O-ring seal sections at both ends. · Insert spool into casing hole, rotate and reciprocate it. 	<ul style="list-style-type: none"> · Replacement when its outside sliding section has scratch (especially on seals-contacting section). · Replacement when its sliding section has scratch. · Correction or replacement when O-ring is damaged or when spool does not move smoothly.
Poppet	<ul style="list-style-type: none"> · Damage of spring · Damage of poppet · Insert poppet into casing and function it. 	<ul style="list-style-type: none"> · Replacement. · Correction or replacement when sealing is incomplete. · Normal when it can function lightly and smoothly without sticking.
Spring and related parts	<ul style="list-style-type: none"> · Rusting, corrosion, deformation or breakage of spring, spring seat, plug or cover. 	<ul style="list-style-type: none"> · Replacement for significant damage.
Around seal for spool	<ul style="list-style-type: none"> · External oil leakage. · Rusting, corrosion or deformation of seal plate. 	<ul style="list-style-type: none"> · Correction or replacement. · Correction or replacement.
Main relief valve, port relief valve & negative control relief valve	<ul style="list-style-type: none"> · External rusting or damage. · Contacting face of valve seat. · Contacting face of poppet. · O-rings and back up rings. 	<ul style="list-style-type: none"> · Replacement. · Replacement when damaged. · Replacement when damaged. · Replacement in principle.

3. SWING DEVICE

1) WEARING PARTS

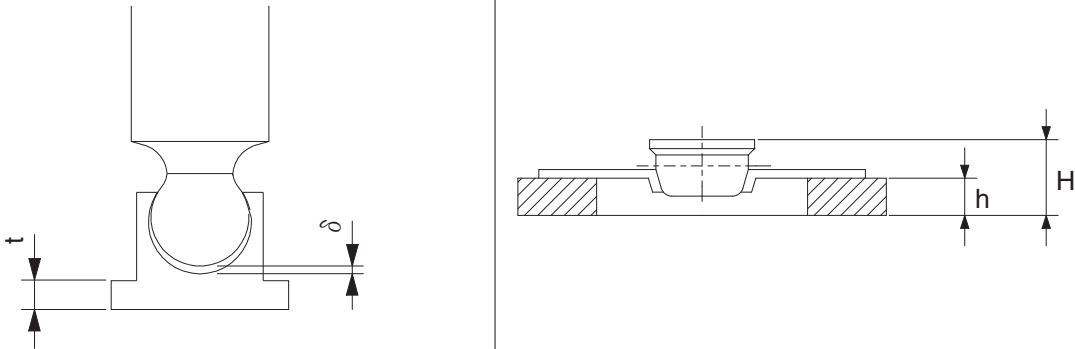
Inspection item	Standard dimension	Recommended replacement value	Counter measures
Clearance between piston and cylinder block bore	0.028	0.058	Replace piston or cylinder block
Play between piston and shoe caulking section (δ)	0	0.3	Replace assembly of piston and shoe
Thickness of shoe (t)	5.5	5.3	Replace assembly of piston and shoe
Combined height of retainer plate and spherical bushing (H-h)	6.5	6.0	Replace set of retainer plate and spherical bushing
Thickness of friction plate	4.0	3.6	Replace
			

2) SLIDING PARTS

Part name	Standard roughness	Allowable roughness	Remark
Shoe	0.8-Z (Ra=0.2) (LAPPING)	3-Z (Ra=0.8)	
Shoe plate	0.4-Z (Ra=0.1) (LAPPING)	3-Z (Ra=0.8)	
Cylinder	1.6-Z (Ra=0.4) (LAPPING)	12.5-Z (Ra=3.2)	
Valve plate	0.8-Z (Ra=0.2) (LAPPING)	6.3-Z (Ra=1.6)	

4. TRAVEL MOTOR

The followings are the general maintenance standards. However, it is the most important to determine which parts should be replaced, depending on the characteristics before disassembling, damages and discoloration of exterior view, the purpose of disassembling, the expected remaining service life. etc..

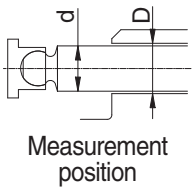
Check item		Measuring method	Criteria	Allowable	Remedy
Sliding surface of cylinder block, valve plate and swash plate	Surface roughness of cylinder block, valve plate and swash plate	Measure the surface roughness by roughness tester	Below $0.4 Z\mu$	Below $3.0 Z\mu$	Replace or repair ※ Lap together the surfaces of both cylinder block and valve plate to remedy their roughness (# 1200 power)
	Swash plate - hardness of sliding surface	Measure the surface hardness of swash plate by hardness tester	Over HS78	HS74	Replace
Clearance between piston and cylinder block 	Outer dia of piston d max - d min	Measure outer dia of piston and bore of cylinder block at least 3 places in the longitudinal direction with micrometer and obtain : max outer dia = d max min outer dia = d min max inner dia = D max min inner dia = D min	0.01 mm	0.05 mm	Replace piston or cylinder block ※ In exchanging pistons, replace all of nine pistons at the same time
	Inner dia of cylinder bore D max - D min		0.01 mm	0.022 mm	
	Clearance $D-d$		0.037~0.047 mm	0.065 mm	
Play between piston and shoe	Play between calked piston and shoe (δ)	With the jig, hold down the shoe on work stand and pull up the piston vertical direction to measure the play between piston and shoe	0~0.1 mm	0.3 mm	Replace piston

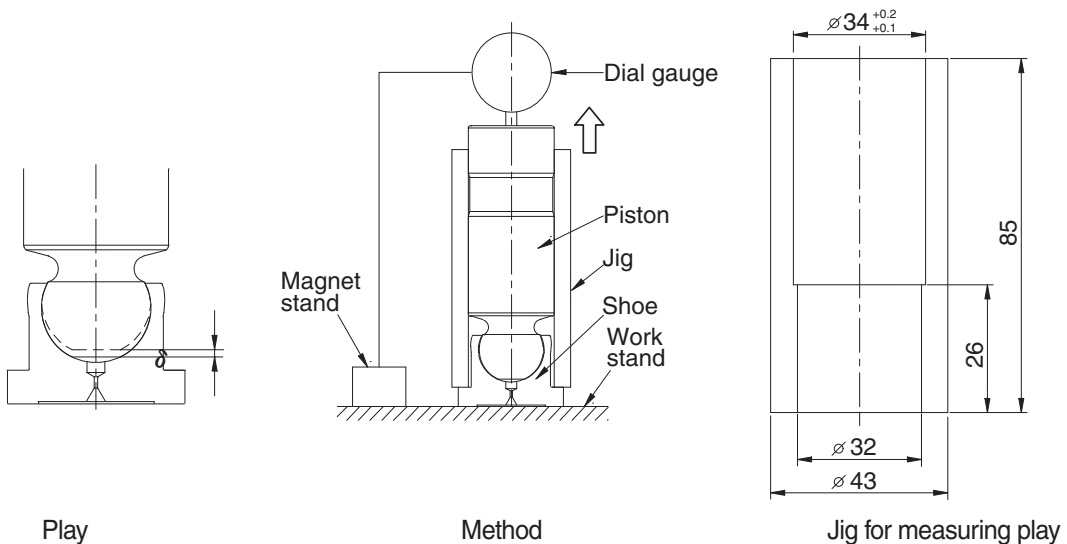

Check item	Measuring method	Criteria	Allowable	Remedy
Parking brake torque	After completion of assembly, set the torque wrench on the shaft end, and measure the braking torque generated when the shaft starts to rotate	92.6 kgf · m (670 lbf · ft)	82.8 kgf · m (599 lbf · ft)	Replace all of separator, friction plates and springs
Standard of replacing friction and separating plate. When measuring parking brake torque, it needs to disassemble traveling unit to motor and reduction gear portion, and it's so hard. The right allowable value is a standard of replacing friction and separating plate. If it is impossible to disassemble traveling unit, refer to the right value.	Measure the total thickness of 4 pieces of friction plate and 5 pieces of separating plate.	22.76 mm	Thickness : 21.3 mm	Replace all separating and friction plates and springs.

Check item	Measuring method	Judging criteria and remedy
Shaft	Measure the wear at contacting surface of oil seal (3) with the surface roughness tester	If the depth of shaft wear is less than 0.05 mm, the shaft is reusable. ※ In case of replacing the shaft (9), replace oil seal (3) at the same time.
Bearings	Replace bearings (10, 51) after decided hours	Replace bearings (10, 51) before hour meter of host machine indicates 10,000 hours. ※ In case replacing the bearings (10, 51), replace both inner and outer races at the same time. ※ Also the bearing shims (52) must be readjusted when replaced shaft (9) and/or bearings (10, 51). Contact dealers for jigs and tools required.
Splines	Replace if the wear of splines exceeds the allowable value	If the wear of splines is less than 0.3 mm, the spline is reusable.
Overload relief valve	Do not try to adjust the valve, since special hydraulic test bench is required for inspecting and adjusting the pressure	Replace relief valve part as an assembly each time the host machine works for 10,000 hours.

Part name & inspection item	Standard dimension	Recommended value for replacement	Remedy
Radial clearance of needle bearing	0.01-0.04 mm	0.07 mm	Replacement of abnormal parts as a set.
Crack of spline contact part	-	-	Replacement if such damage as crack, crevice or chipping is found.
Backlash of spline contact part	0.1-0.3 mm	0.5 mm	Dimension check and replacement according to following standards.
Thrust ring (026)	7 mm thick	6.6 mm	Replacement if severe wear or seizure is found on sliding surface.
Thrust ring (027)	8 mm thick	7.6 mm	
Floating seal	-	-	Replacement if scratch or rust is found in sliding surface. Replacement if O-ring is deformed or damaged.
Gear oil	SAE 85W-140 (API GL-5)	-	1st time : 500hr 2nd time and later : Every 2000hr After disassembling, fill with new oil without fail. The above times are measured with engine hour meter.

5. RCV LEVER

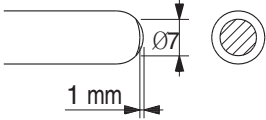
Maintenance check item	Criteria	Remark
Leakage	The valve is to be replaced when the leakage becomes more than 1000 cc/m at neutral handle position, or more than 2000 cc/m during operation.	Conditions : Primary pressure : 40 kgf/cm ² Oil viscosity : 23 cSt
Spool	This is to be replaced when the sliding surface has worn more than 10 μm, compared with the non-sliding surface.	The leakage at the left condition is estimated to be nearly equal to the above leakage.
Push rod	 <p>This is to be replaced when the top end has worn more than 1 mm.</p>	
Play at operating section	The pin, shaft, and joint of the operating section are to be replaced when their plays become more than 2 mm due to wears or so on.	When a play is due to looseness of a tightened section, adjust it.
Operation stability	When abnormal noises, hunting, primary pressure drop, etc. are generated during operation, and these cannot be remedied, referring to section 6. Troubleshooting, replace the related parts.	

Notes 1. It is desirable to replace seal materials, such as O-rings, every disassembling. However, they may be reused, after being confirmed to be free of damage.

6. RCV PEDAL

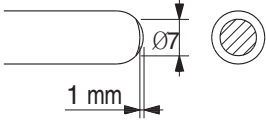
Maintenance check item	Criteria	Remark
Leakage	The valve is to be replaced when the leakage effect to the system. For example, the primary pressure drop.	Conditions : Primary pressure : 40 kgf/cm ² Oil viscosity : 23 cSt
Spool	This is to be replaced when the sliding surface has worn more than 10 μm, compared with the non-sliding surface.	The leakage at the left condition is estimated to be nearly equal to the above leakage.
Push rod	 <p>This is to be replaced when the top end has worn more than 1 mm.</p>	
Play at operating section	The pin, shaft, and joint of the operating section are to be replaced when their plays become more than 2 mm due to wears or so on.	When a play is due to looseness of a tightened section, adjust it.
Operation stability	When abnormal noises, hunting, primary pressure drop, etc. are generated during operation, and these cannot be remedied, referring to section 6. Troubleshooting, replace the related parts.	

Notes 1. It is desirable to replace seal materials, such as O-rings, every disassembling. However, they may be reused, after being confirmed to be free of damage.

7. TURNING JOINT

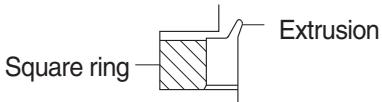
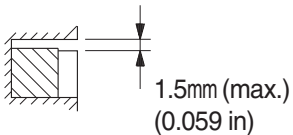
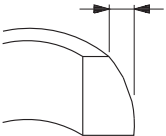
Part name		Maintenance standards	Remedy
Body, Stem	Sliding surface with sealing sections.	Plating worn or peeled due to seizure or contamination.	Replace
	Sliding surface between body and stem other than sealing section.	· Worn abnormality or damaged more than 0.1 mm (0.0039 in) in depth due to seizure contamination.	Replace
		· Damaged more than 0.1 mm (0.0039 in) in depth.	Smooth with oilstone.
	Sliding surface with thrust plate.	· Worn more than 0.5 mm (0.02 in) or abnormality.	Replace
		· Worn less than 0.5 mm (0.02 in).	Smooth
	· Damage due to seizure or contamination remediable within wear limit (0.5 mm) (0.02 in).	Smooth	
Cover	Sliding surface with thrust plate.	· Worn more than 0.5 mm (0.02 in) or abnormality.	Replace
		· Worn less than 0.5 mm (0.02 in).	Smooth
		· Damage due to seizure or contamination remediable within wear limit (0.5 mm) (0.02 in).	Replace
Seal set	-	<ul style="list-style-type: none"> · Extruded excessively from seal groove square ring. 	Replace
	-	<ul style="list-style-type: none"> · Slipper ring 1.5 mm (0.059 in) narrower than seal groove, or narrower than back ring. 	Replace
	-	<ul style="list-style-type: none"> · Worn more than 0.5 mm (0.02 in) ~ 1.5 mm (MAX.) (0.059 in) 	Replace

8. CYLINDER

Part name	Inspecting section	Inspection item	Remedy
Piston rod	· Neck of rod pin	· Presence of crack	· Replace
	· Weld on rod hub	· Presence of crack	· Replace
	· Stepped part to which piston is attached.	· Presence of crack	· Replace
	· Threads	· Presence of crack	· Recondition or replace
	· Plated surface	· Plating is not worn off to base metal.	· Replace or replate
		· Rust is not present on plating. · Scratches are not present.	· Replace or replate · Recondition, replate or replace
	· Rod	· Wear of O.D.	· Recondition, replate or replace
· Bushing at mounting part	· Wear of I.D.	· Replace	
Cylinder tube	· Weld on bottom	· Presence of crack	· Replace
	· Weld on head	· Presence of crack	· Replace
	· Weld on hub	· Presence of crack	· Replace
	· Tube interior	· Presence of faults	· Replace if oil leak is seen
	· Bushing at mounting part	· Wear on inner surface	· Replace
Gland	· Bushing	· Flaw on inner surface	· Replace if flaw is deeper than coating

GROUP 3 TRACK AND WORK EQUIPMENT

1. TRACK

1) TRACK ROLLER

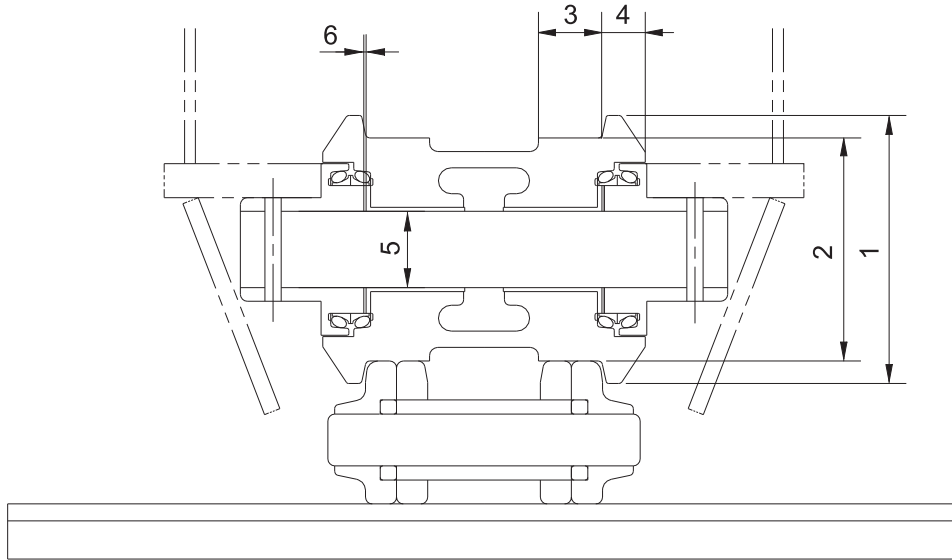

32077MS01

Unit : mm

No.	Check item	Criteria				Remedy
		Standard size		Repair limit		
1	Outside diameter of flange	ø 250		-		Rebuild or replace
2	Outside diameter of tread	ø 210		ø 198		
3	Width of tread	54.6		60.6		
4	Width of flange	34.4		-		
5	Clearance between shaft and bushing	Standard size & tolerance		Standard clearance	Clearance limit	Replace bushing
		Shaft	Hole			
		ø 85 -0.25 -0.35	ø 85 +0.176 +0.029	0.279 to 0.526	2.0	
6	Side clearance of roller (both side)	Standard clearance		Clearance limit		Replace
		0.12~1.3		2.0		

2) CARRIER ROLLER

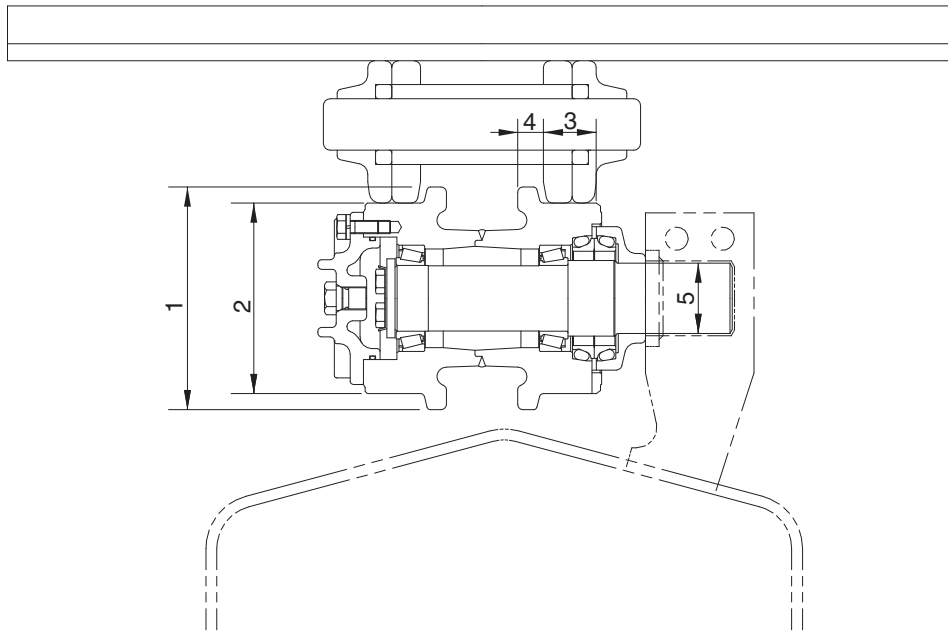

4507AMS04

Unit : mm

No.	Check item	Criteria				Remedy
		Standard size		Repair limit		
1	Outside diameter of flange	ø 220		-		Rebuild or replace
2	Outside diameter of tread	ø 191		ø 181		
3	Width of tread	51		56		
4	Width of flange	20		-		
5	Clearance between shaft and support	Standard size & tolerance		Standard clearance	Clearance limit	Replace
		Shaft	Hole			
		ø 57.15 _{-0.1} ⁰	ø 57.15 _{+0.1} ^{+0.3}	0.1 to 0.4	1.2	

3) IDLER

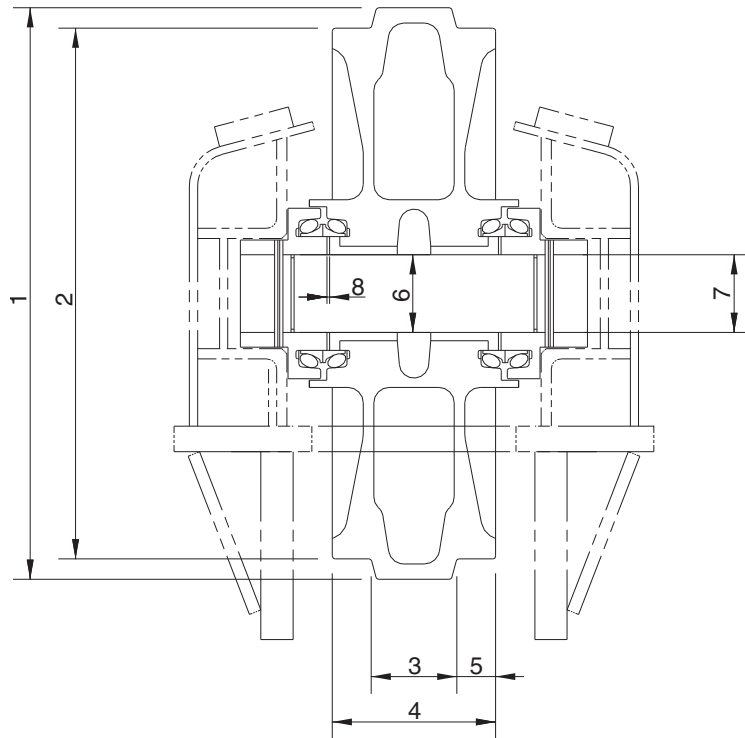

4707AMS03

Unit : mm

No.	Check item	Criteria		Remedy		
		Standard size	Repair limit			
1	Outside diameter of protrusion	∅ 682	-	Rebuild or replace		
2	Outside diameter of tread	∅ 630	∅ 616			
3	Width of protrusion	102	-			
4	Total width	203	-			
5	Width of tread	50.5	57.5			
6	Clearance between shaft and support	Standard size & tolerance		Standard clearance	Clearance limit	Replace bushing
		Shaft	Hole			
		∅ 85 $\begin{matrix} 0 \\ -0.035 \end{matrix}$	∅ 85.35 $\begin{matrix} +0.05 \\ 0 \end{matrix}$	0.35 to 0.435	2.0	
7	Clearance between shaft and support	∅ 85 $\begin{matrix} 0 \\ -0.035 \end{matrix}$	∅ 85 $\begin{matrix} +0.09 \\ +0.036 \end{matrix}$	0.036 to 0.125	1.2	Replace
8	Side clearance of idler (Both side)	Standard clearance		Clearance limit		Replace
		0.25 to 1.2		2.0		

4) TRACK

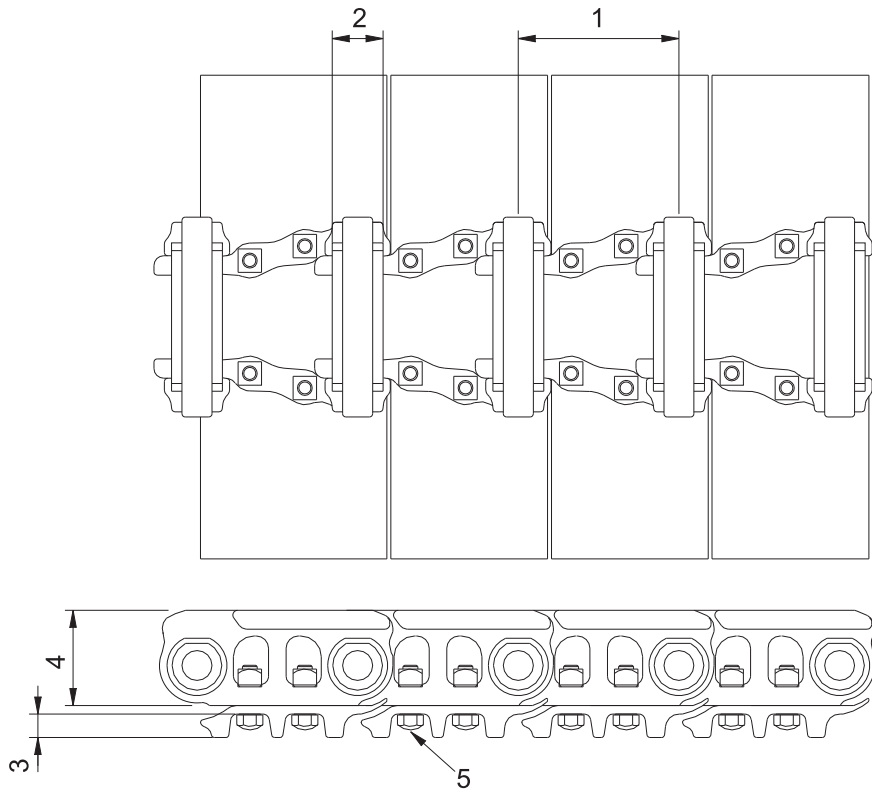

32077MS04

Unit : mm

No.	Check item	Criteria		Remedy
		Standard size	Repair limit	
1	Link pitch	215.9	226.7	Turn or replace
2	Outside diameter of bushing	∅ 71	∅ 60.4	Rebuild or replace
3	Height of grouser	36	21	
4	Height of link	129	115	Retighten
5	Tightening torque	Initial tightening torque : 105 ± 5 kgf · m		

5) TRACK FRAME AND RECOIL SPRING

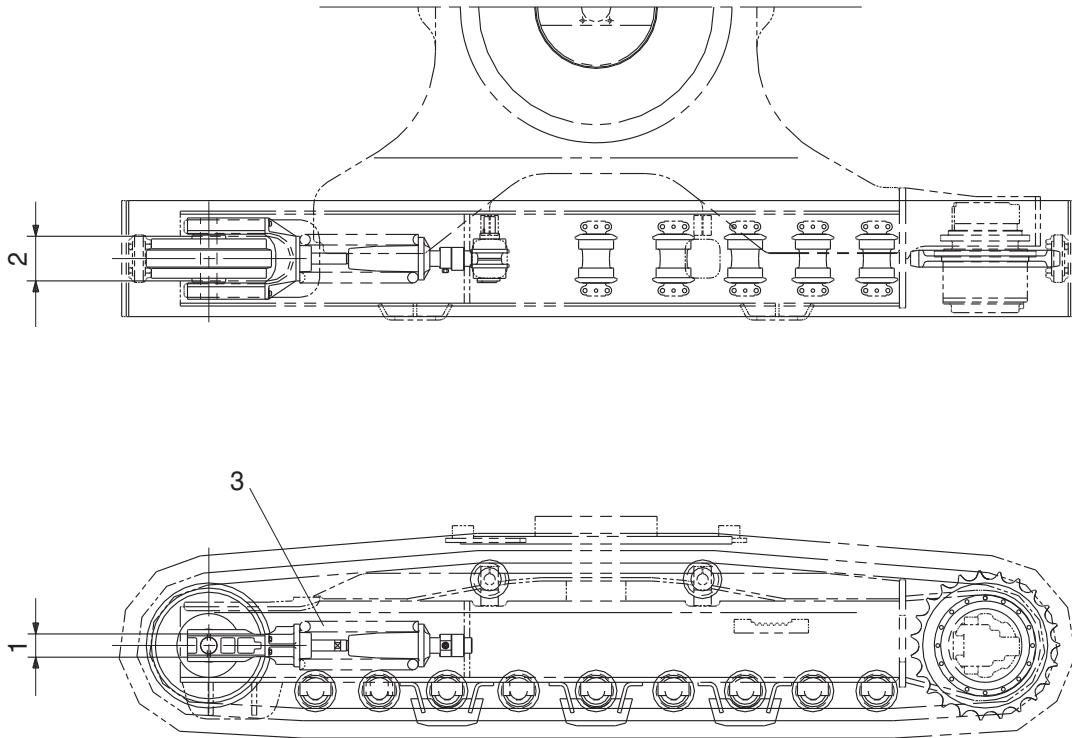

21073MS05

Unit : mm

No.	Check item	Criteria				Remedy	
			Standard size	Tolerance	Repair limit		
1	Vertical width of idler guide	Track frame	123	+2 -1	137	Rebuild or replace	
		Idler support	120	0 -1.5	116		
2	Horizontal width of idler guide	Track frame	292	+2 -1	296		
		Idler support	290	-	287		
3	Recoil spring	Standard size		Repair limit		Replace	
		Free length	Installation length	Installation load	Free length		Installation load
		∅ 254 × 740	595	24500 kg	-		19600 kg

2. WORK EQUIPMENT

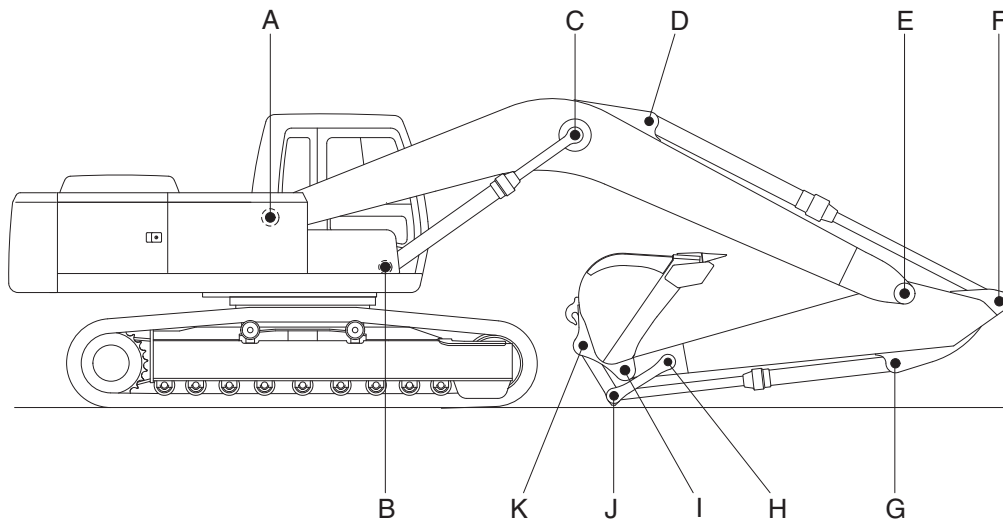

21077MS20

Unit : mm

Mark	Measuring point (Pin and Bushing)	Normal value	Pin		Bushing		Remedy & Remark
			Recomm. service limit	Limit of use	Recomm. service limit	Limit of use	
A	Boom Rear	120	119	118.5	120.5	121	Replacement
B	Boom Cylinder Head	100	99	98.5	100.5	101	
C	Boom Cylinder Rod	110	109	108.5	110.5	111	
D	Arm Cylinder Head	110	109	108.5	110.5	111	
E	Boom Front	110	109	108.5	110.5	111	
F	Arm Cylinder Rod	110	109	108.5	110.5	111	
G	Bucket Cylinder Head	90	89	88.5	90.5	91	
H	Arm Link	90	89	88.5	90.5	91	
I	Bucket and Arm Link	100	99	98.5	100.5	101	
J	Bucket Cylinder Rod	90	89	88.5	90.5	91	
K	Bucket Link	100	99	98.5	100.5	101	