

SECTION 1 GENERAL



Group 1 Safety Hints	1-1
Group 2 Specifications	1-10

SECTION 1 GENERAL

GROUP 1 SAFETY

FOLLOW SAFE PROCEDURE

Unsafe work practices are dangerous. Understand service procedure before doing work; Do not attempt shortcuts.

WEAR PROTECTIVE CLOTHING

Wear close fitting clothing and safety equipment appropriate to the job.

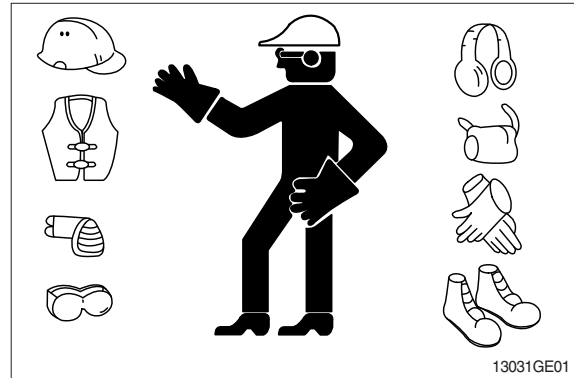

WARN OTHERS OF SERVICE WORK

Unexpected machine movement can cause serious injury.

Before performing any work on the excavator, attach a 「Do Not Operate」 tag on the right side control lever.

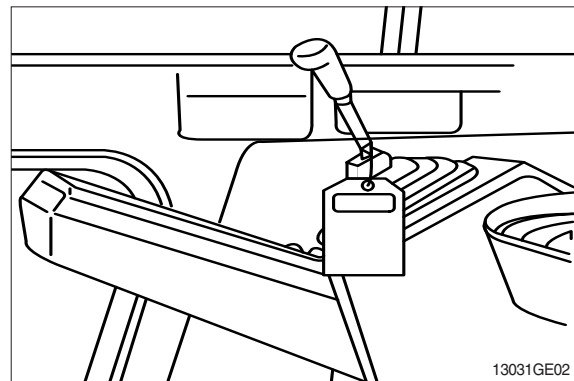

USE HANDHOLDS AND STEPS

Falling is one of the major causes of personal injury.

When you get on and off the machine, always maintain a three point contact with the steps and handrails and face the machine. Do not use any controls as handholds.

Never jump on or off the machine. Never mount or dismount a moving machine.

Be careful of slippery conditions on platforms, steps, and handrails when leaving the machine.

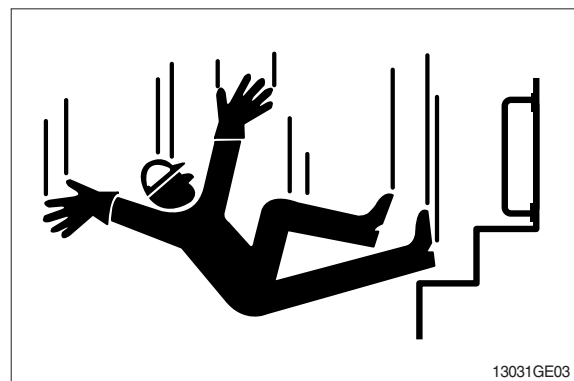

PREPARE FOR EMERGENCIES

Be prepared if a fire starts.

Keep a first aid kit and fire extinguisher handy.

Keep emergency numbers for doctors, ambulance service, hospital, and fire department near your telephone.

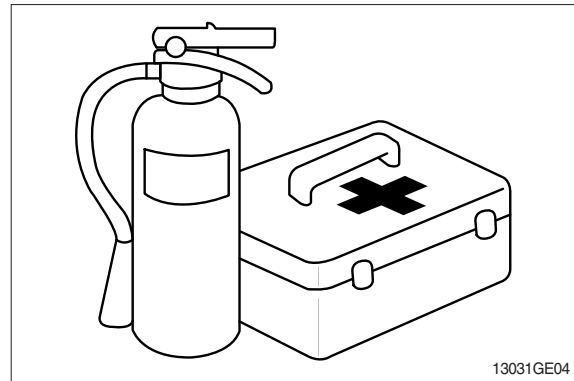

PROTECT AGAINST FLYING DEBRIS

Guard against injury from flying pieces of metal or debris; Wear goggles or safety glasses.

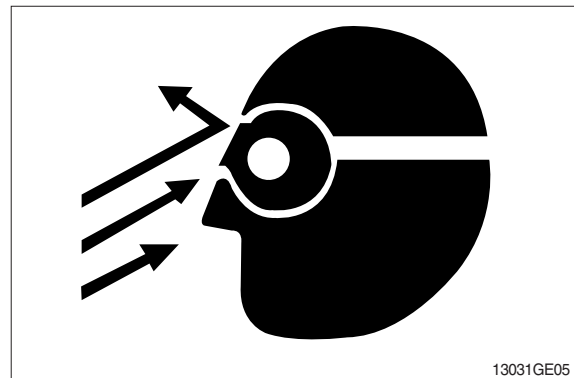

PROTECT AGAINST NOISE

Prolonged exposure to loud noise can cause impairment or loss of hearing.

Wear a suitable hearing protective device such as earmuffs or earplugs to protect against objectionable or uncomfortable loud noises.

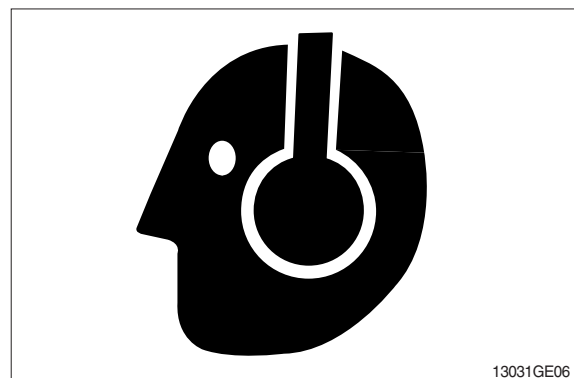

AVOID POWER LINES

Serious injury or death can result from contact with electric lines.

Never move any part of the machine or load closer to electric line than 3m(10ft) plus twice the line insulator length.

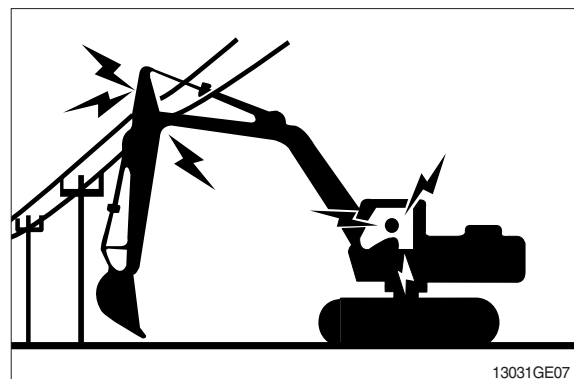

KEEP RIDERS OFF EXCAVATOR

Only allow the operator on the excavator. Keep riders off.

Riders on excavator are subject to injury such as being struck by foreign objects and being thrown off the excavator. Riders also obstruct the operator's view resulting in the excavator being operated in an unsafe manner.

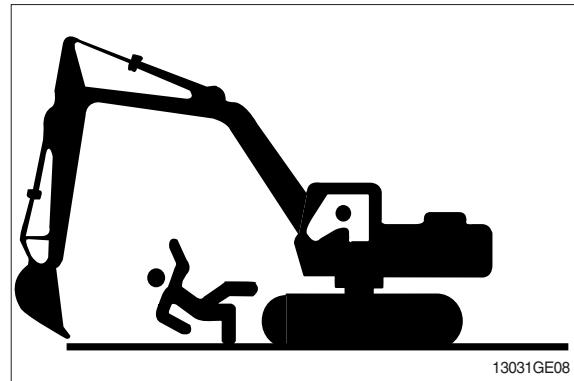

MOVE AND OPERATE MACHINE SAFELY

Bystanders can be run over. Know the location of bystanders before moving, swinging, or operating the machine.

Always keep the travel alarm in working condition. It warns people when the excavator starts to move.

Use a signal person when moving, swinging, or operating the machine in congested areas. Coordinate hand signals before starting the excavator.

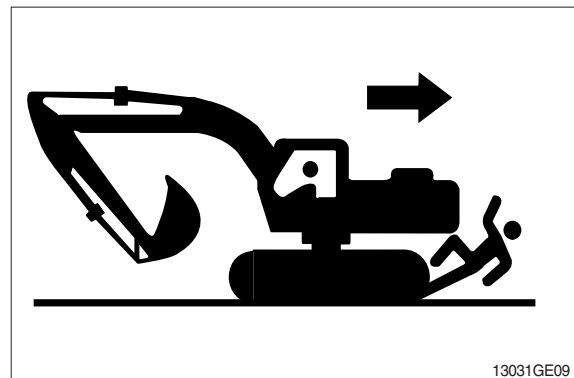

OPERATE ONLY FROM OPERATOR'S SEAT

Avoid possible injury machine damage. Do not start engine by shorting across starter terminals.

NEVER start engine while standing on ground. Start engine only from operator's seat.



PARK MACHINE SAFELY

Before working on the machine:

- Park machine on a level surface.
- Lower bucket to the ground.
- Turn auto idle switch off.
- Run engine at 1/2 speed without load for 2 minutes.
- Turn key switch to OFF to stop engine. Remove key from switch.
- Move pilot control shutoff lever to locked position.
- Allow engine to cool.

SUPPORT MACHINE PROPERLY

Always lower the attachment or implement to the ground before you work on the machine. If you must work on a lifted machine or attachment, securely support the machine or attachment.

Do not support the machine on cinder blocks, hollow tiles, or props that may crumble under continuous load.

Do not work under a machine that is supported solely by a jack. Follow recommended procedures in this manual.

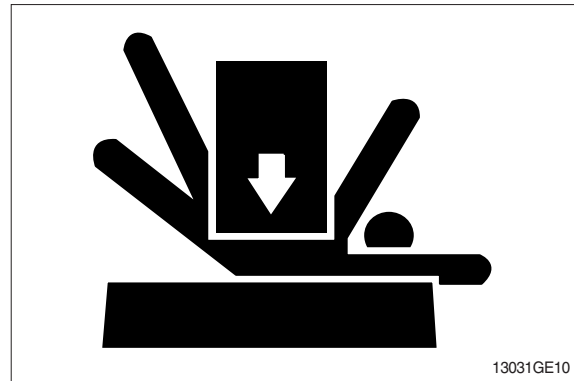

SERVICE COOLING SYSTEM SAFELY

Explosive release of fluids from pressurized cooling system can cause serious burns.

Shut off engine. Only remove filler cap when cool enough to touch with bare hands.

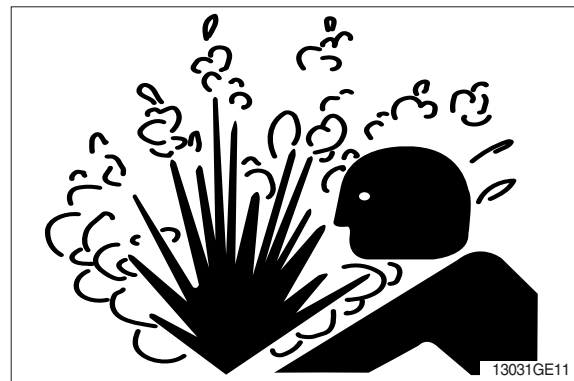

HANDLE FLUIDS SAFELY-AVOID FIRES

Handle fuel with care; It is highly flammable. Do not refuel the machine while smoking or when near open flame or sparks. Always stop engine before refueling machine. Fill fuel tank outdoors.



Store flammable fluids away from fire hazards. Do not incinerate or puncture pressurized containers.

Make sure machine is clean of trash, grease, and debris.

Do not store oily rags; They can ignite and burn spontaneously.

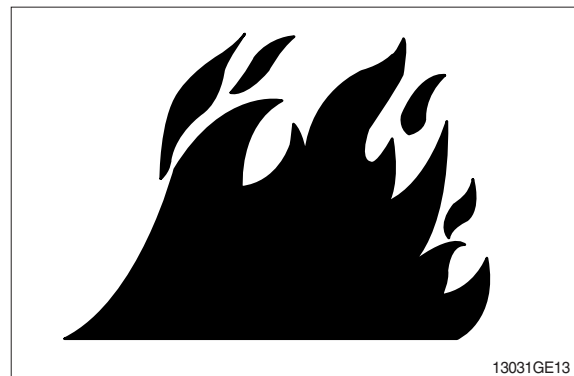

BEWARE OF EXHAUST FUMES

Prevent asphyxiation. Engine exhaust fumes can cause sickness or death.

If you must operate in a building, be positive there is adequate ventilation. Either use an exhaust pipe extension to remove the exhaust fumes or open doors and windows to bring enough outside air into the area.

REMOVE PAINT BEFORE WELDING OR HEATING

Avoid potentially toxic fumes and dust.

Hazardous fumes can be generated when paint is heated by welding, soldering, or using a torch.

Do all work outside or in a well ventilated area. Dispose of paint and solvent properly.

Remove paint before welding or heating:

- If you sand or grind paint, avoid breathing the dust.
Wear an approved respirator.
- If you use solvent or paint stripper, remove stripper with soap and water before welding. Remove solvent or paint stripper containers and other flammable material from area. Allow fumes to disperse at least 15 minutes before welding or heating.

ILLUMINATE WORK AREA SAFELY

Illuminate your work area adequately but safely. Use a portable safety light for working inside or under the machine. Make sure the bulb is enclosed by a wire cage. The hot filament of an accidentally broken bulb can ignite spilled fuel or oil.

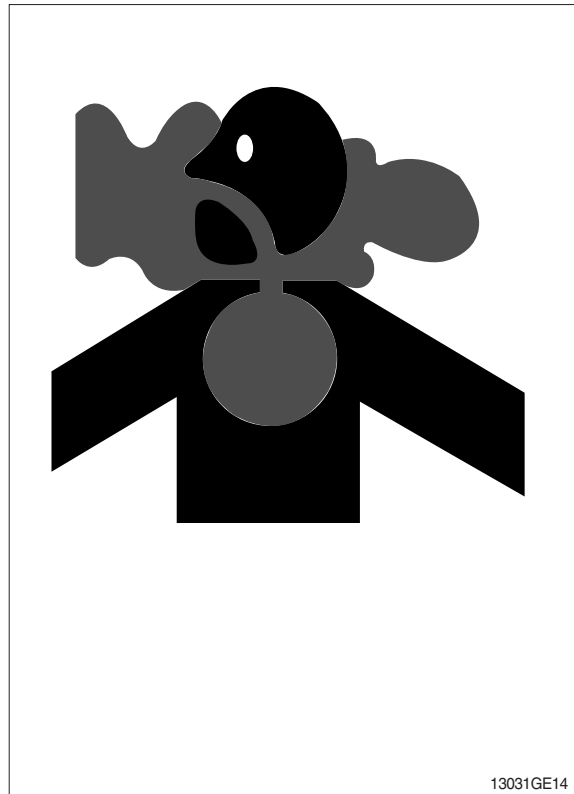

SERVICE MACHINE SAFELY

Tie long hair behind your head. Do not wear a necktie, scarf, loose clothing or necklace when you work near machine tools or moving parts. If these items were to get caught, severe injury could result.

Remove rings and other jewelry to prevent electrical shorts and entanglement in moving parts.

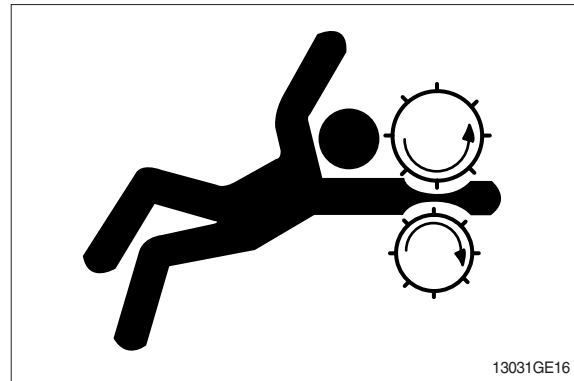

STAY CLEAR OF MOVING PARTS

Entanglements in moving parts can cause serious injury.

To prevent accidents, use care when working around rotating parts.

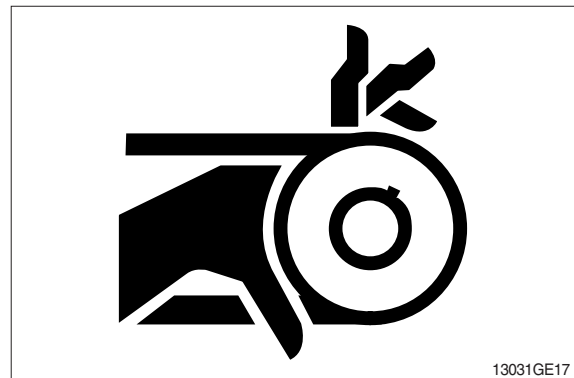

AVOID HIGH PRESSURE FLUIDS

Escaping fluid under pressure can penetrate the skin causing serious injury.

Avoid the hazard by relieving pressure before disconnecting hydraulic or other lines. Tighten all connections before applying pressure.

Search for leaks with a piece of cardboard. Protect hands and body from high pressure fluids.

If an accident occurs, see a doctor immediately. Any fluid injected into the skin must be surgically removed within a few hours or gangrene may result.

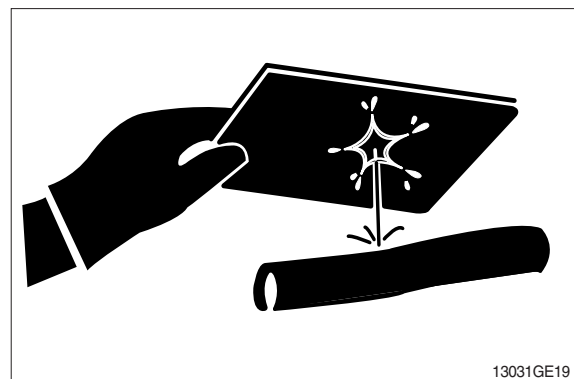

AVOID HEATING NEAR PRESSURIZED FLUID LINES

Flammable spray can be generated by heating near pressurized fluid lines, resulting in severe burns to yourself and bystanders. Do not heat by welding, soldering, or using a torch near pressurized fluid lines or other flammable materials.

Pressurized lines can be accidentally cut when heat goes beyond the immediate flame area. Install fire resisting guards to protect hoses or other materials.



PREVENT BATTERY EXPLOSIONS

Keep sparks, lighted matches, and flame away from the top of battery. Battery gas can explode.

Never check battery charge by placing a metal object across the posts. Use a volt-meter or hydrometer.

Do not charge a frozen battery; It may explode. Warm battery to 16°C (60°F).



PREVENT ACID BURNS

Sulfuric acid in battery electrolyte is poisonous. It is strong enough to burn skin, eat holes in clothing, and cause blindness if splashed into eyes.

Avoid the hazard by:

1. Filling batteries in a well-ventilated area.
2. Wearing eye protection and rubber gloves.
3. Avoiding breathing fumes when electrolyte is added.
4. Avoiding spilling or dripping electrolyte.
5. Use proper jump start procedure.

If you spill acid on yourself:

1. Flush your skin with water.
2. Apply baking soda or lime to help neutralize the acid.
3. Flush your eyes with water for 10-15 minutes. Get medical attention immediately.

If acid is swallowed:

1. Drink large amounts of water or milk.
2. Then drink milk of magnesia, beaten eggs, or vegetable oil.
3. Get medical attention immediately.

USE TOOLS PROPERLY

Use tools appropriate to the work. Makeshift tools, parts, and procedures can create safety hazards.

Use power tools only to loosen threaded tools and fasteners.

For loosening and tightening hardware, use the correct size tools. **DO NOT** use U.S. measurement tools on metric fasteners. Avoid bodily injury caused by slipping wrenches.

Use only recommended replacement parts. (See Parts catalogue.)

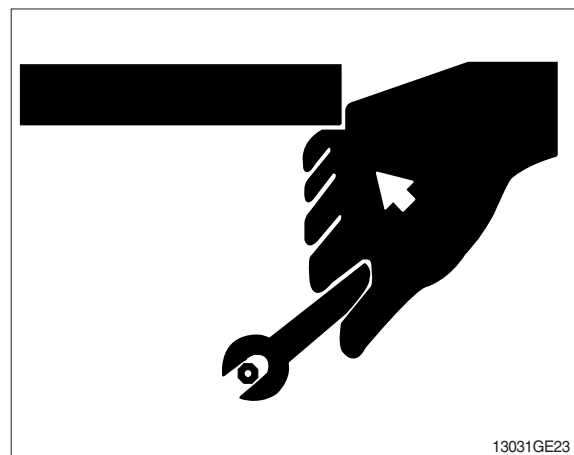
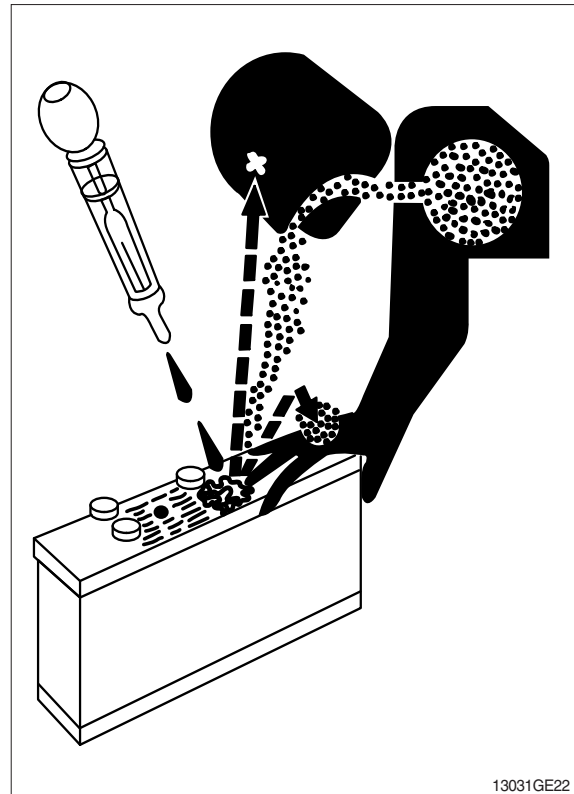

DISPOSE OF FLUIDS PROPERLY

Improperly disposing of fluids can harm the environment and ecology. Before draining any fluids, find out the proper way to dispose of waste from your local environmental agency.

Use proper containers when draining fluids. Do not use food or beverage containers that may mislead someone into drinking from them.

DO NOT pour oil into the ground, down a drain, or into a stream, pond, or lake. Observe relevant environmental protection regulations when disposing of oil, fuel, coolant, brake fluid, filters, batteries, and other harmful waste.

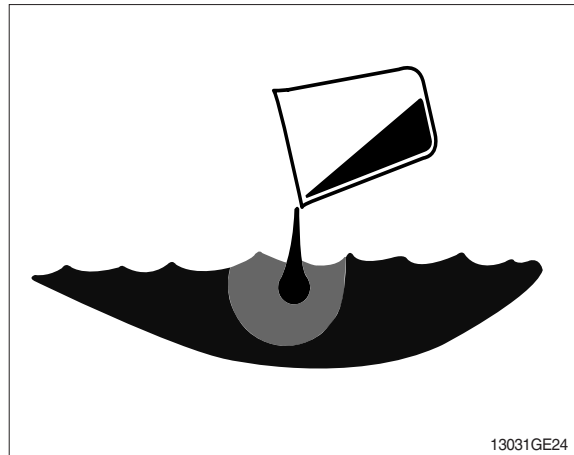

REPLACE SAFETY SIGNS

Replace missing or damaged safety signs. See the machine operator's manual for correct safety sign placement.

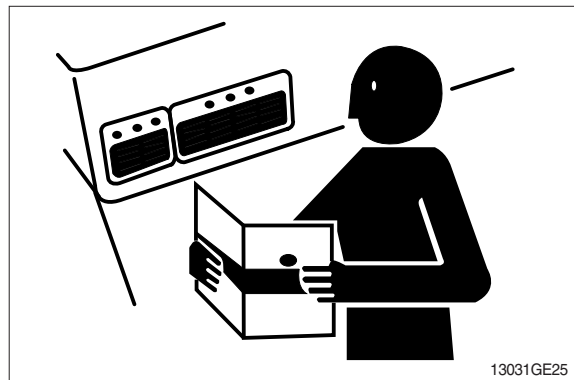

LIVE WITH SAFETY

Before returning machine to customer, make sure machine is functioning properly, especially the safety systems. Install all guards and shields.

GROUP 2 SPECIFICATIONS

1. MAJOR COMPONENT

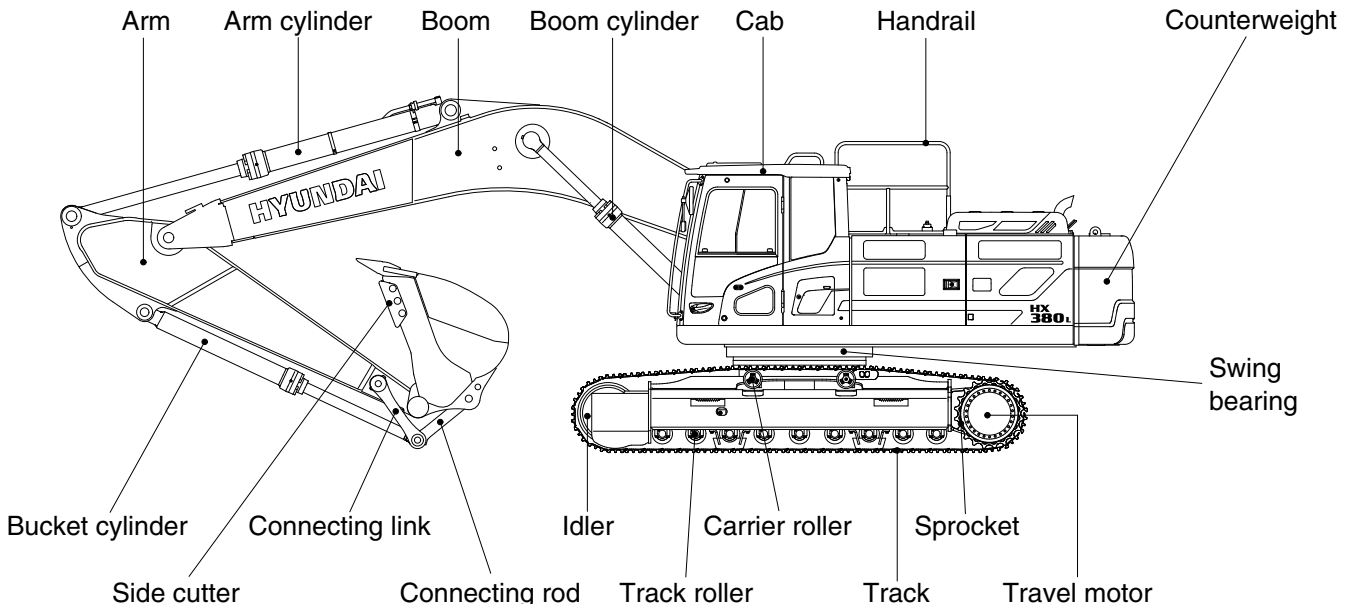
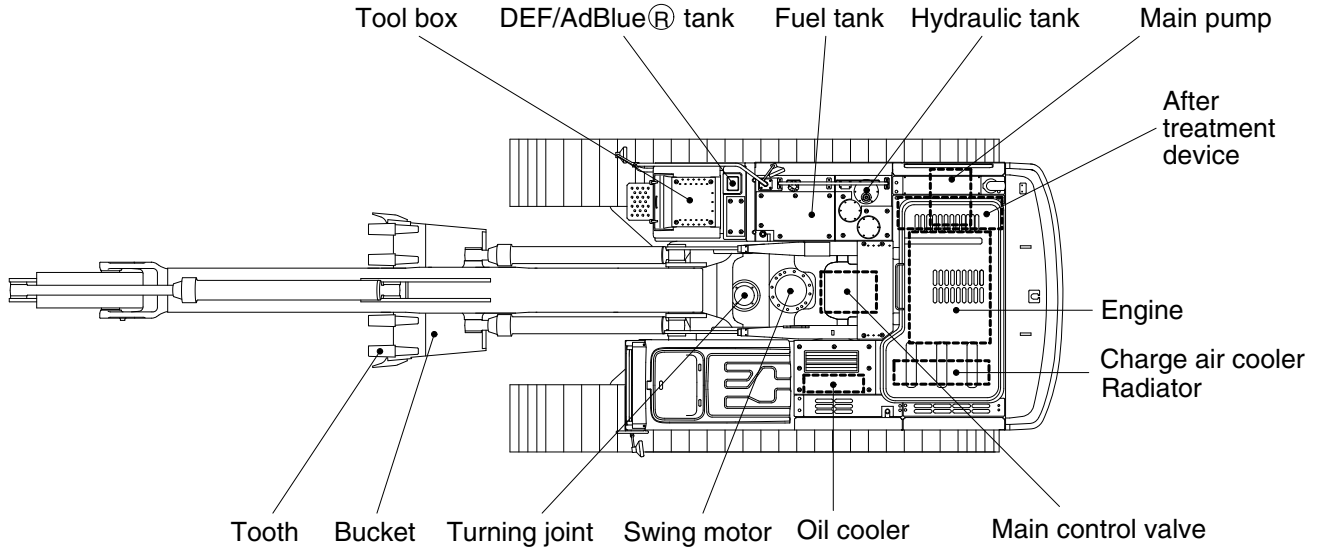

380F2SP01

2. SPECIFICATIONS

1) HX380 L

· 6.5 m (21' 4") BOOM and 3.2 m (10' 6") ARM

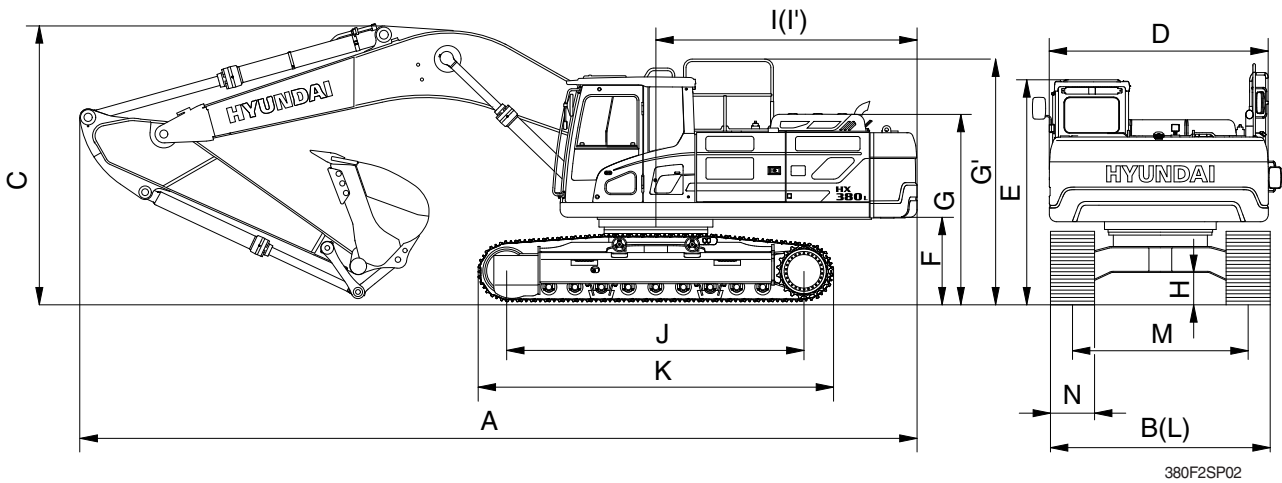

380F2SP02

Description	Unit	Specification
Operating weight	kg (lb)	38920 (85800)
Bucket capacity (SAE heaped), standard	m ³ (yd ³)	1.62 (2.12)
Overall length	A	11400 (37' 5")
Overall width, with 600 mm shoe	B	3340 (10'11")
Overall height	C	3630 (11' 11")
Superstructure width	D	2980 (9' 9")
Overall height of cab	E	3240 (10' 8")
Ground clearance of counterweight	F	1295 (4' 3")
Overall height of engine hood	G	2755 (9' 0")
Overall height of handrail	G'	3445 (11' 4")
Minimum ground clearance	H	550 (1' 10")
Rear-end distance	I	3555 (11' 8")
Rear-end swing radius	I'	3640 (11' 11")
Distance between tumblers	J	4340 (14' 3")
Undercarriage length	K	5220 (17' 1 ")
Undercarriage width	L	3340 (10' 11")
Track gauge	M	2740 (9' 0")
Track shoe width, standard	N	600 (24")
Travel speed (low/high)	km/hr (mph)	3.1/5.0 (1.9/3.1)
Swing speed	rpm	9.5
Gradeability	Degree (%)	35 (70)
Ground pressure (600 mm shoe)	kgf/cm ² (psi)	0.70 (9.95)
Max traction force	kg (lb)	30500 (67240)

2) HX380 NL

· 6.5 m (21' 4") BOOM and 3.2 m (10' 6") ARM

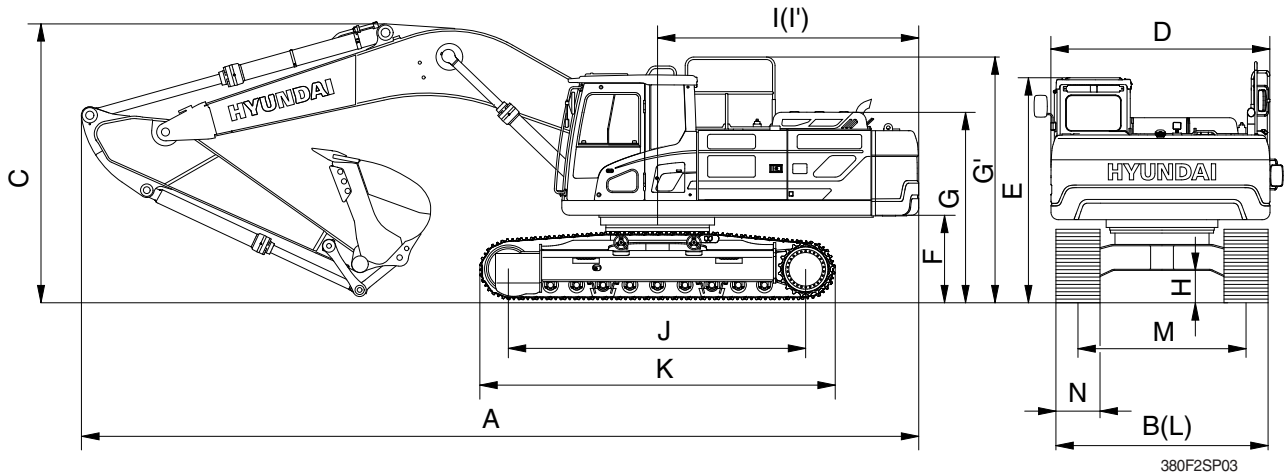

Description		Unit	Specification
Operating weight		kg (lb)	38820 (85580)
Bucket capacity (SAE heaped), standard		m ³ (yd ³)	1.62 (2.12)
Overall length	A	mm (ft-in)	11400 (37' 5")
Overall width, with 600 mm shoe	B		2990 (9' 10")
Overall height	C		3630 (11' 11")
Superstructure width	D		2980 (9' 9")
Overall height of cab	E		3240 (10' 8")
Ground clearance of counterweight	F		1295 (4' 3")
Overall height of engine hood	G		2755 (9' 0")
Overall height of handrail	G'		3445 (11' 4")
Minimum ground clearance	H		550 (1' 10")
Rear-end distance	I		3555 (11' 8")
Rear-end swing radius	I'		3640 (11' 11")
Distance between tumblers	J		4340 (14' 3")
Undercarriage length	K		5220 (17' 1")
Undercarriage width	L		2990 (9' 10")
Track gauge	M		2390 (7' 10")
Track shoe width, standard	N		600 (24")
Travel speed (low/high)		km/hr (mph)	3.1/5.0 (1.9/3.1)
Swing speed		rpm	9.5
Gradeability		Degree (%)	35 (70)
Ground pressure (600 mm shoe)		kgf/cm ² (psi)	0.70 (9.95)
Max traction force		kg (lb)	30500 (67240)

3. WORKING RANGE

1) HX380 L, HX380 NL [6.5 m (21' 4") BOOM]

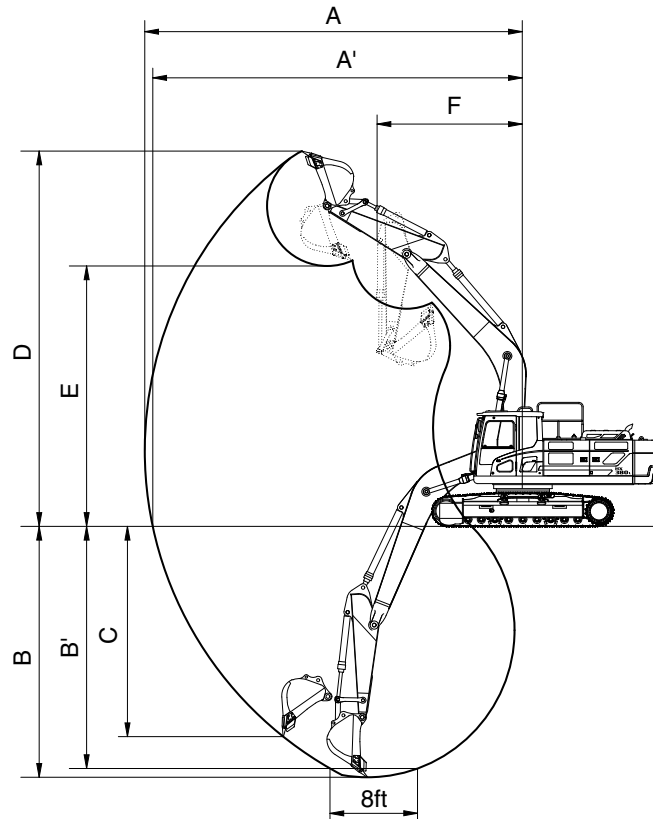

380F2SP04

Description		2.5 m (8' 2") Arm	3.2 m (10' 6") Arm	3.9 m (12' 10") Arm
Max digging reach	A	10650 mm (31' 11")	11160 mm (36' 7")	11820 mm (38' 9")
Max digging reach on ground	A'	10410 mm (34' 2")	10930 mm (35' 10")	11620 mm (38' 1")
Max digging depth	B	6820 mm (22' 5")	7520 mm (24' 8")	8220 mm (27' 0")
Max digging depth (8ft level)	B'	6640 mm (21' 9")	7360 mm (24' 2")	8080 mm (26' 6")
Max vertical wall digging depth	C	5030 mm (16' 6")	5480 mm (18' 0")	6300 mm (20' 8")
Max digging height	D	10330 mm (33' 11")	10270 mm (33' 8")	10610 mm (34' 10")
Max dumping height	E	7190 mm (23' 7")	7190 mm (23' 7")	7500 mm (24' 7")
Min swing radius	F	4490 mm (14' 9")	4490 mm (14' 9")	4350 mm (14' 3")
Bucket digging force	SAE	201.0 [219.3] kN	201.0 [219.3] kN	201.0 [219.3] kN
		20500 [22360] kgf	20500 [22360] kgf	20500 [22360] kgf
		45190 [49300] lbf	45190 [49300] lbf	45190 [49300] lbf
	ISO	228.5 [249.3] kN	228.5 [249.3] kN	228.5 [249.3] kN
		23300 [25420] kgf	23300 [25420] kgf	23300 [25420] kgf
		51370 [56040] lbf	51370 [56040] lbf	51370 [56040] lbf
Arm crowd force	SAE	192.2 [209.7] kN	160.8 [175.4] kN	137.3 [149.7] kN
		19600 [21380] kgf	16400 [17890] kgf	14000 [15270] kgf
		43210 [47130] lbf	36160 [39440] lbf	30860 [33660] lbf
	ISO	200.1 [218.2] kN	165.7 [180.8] kN	141.2 [154.1] kN
		20400 [22250] kgf	16900 [18440] kgf	14400 [15710] kgf
		44970 [49050] lbf	37260 [40650] lbf	31750 [34630] lbf

[] : Power boost

2) HX380 L, HX380 NL [6.15 m (20' 2") BOOM]

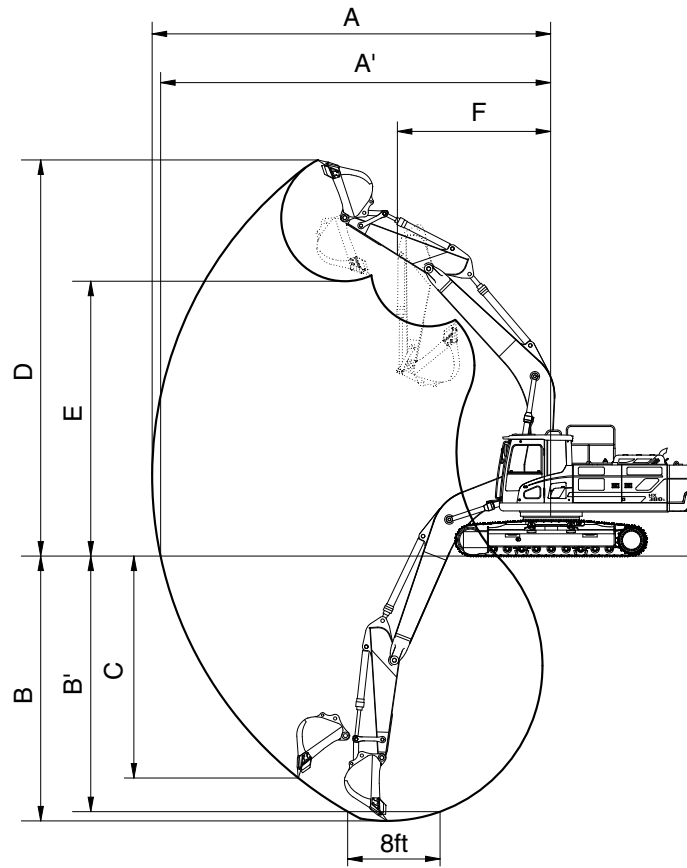

380F2SP04

Description		2.5 m (8' 2") Arm
Max digging reach	A	10300 mm (33' 10")
Max digging reach on ground	A'	10060 mm (33' 0")
Max digging depth	B	6560 mm (21' 6")
Max digging depth (8ft level)	B'	6380 mm (20' 11")
Max vertical wall digging depth	C	4780 mm (15' 8")
Max digging height	D	10000 mm (32' 10")
Max dumping height	E	6870 mm (22' 6")
Min swing radius	F	4310 mm (14' 2")
Bucket digging force	SAE	201.0 [219.3] kN
		20500 [22360] kgf
		45190 [49300] lbf
	ISO	228.5 [249.3] kN
		23300 [25420] kgf
		51370 [56040] lbf
Arm crowd force	SAE	192.2 [209.7] kN
		19600 [21380] kgf
		43210 [47130] lbf
	ISO	200.1 [218.2] kN
		20400 [22250] kgf
		44970 [49050] lbf

[] : Power boost

4. WEIGHT

Item		HX380 L		HX380 NL	
		kg	lb	kg	lb
Upperstructure assembly		16180	35670	←	←
Main frame weld assembly		3045	6710	←	←
Engine assembly		710	1565	←	←
Main pump assembly		190	420	←	←
Main control valve assembly		340	750	←	←
Swing motor assembly		360	790	←	←
Hydraulic oil tank assembly		340	750	←	←
Fuel tank assembly		260	570	←	←
Counterweight	6.5, 6.15 m boom	6500	14330	←	←
	8.6 m boom	8100	17860	-	-
Cab assembly		490	1080	←	←
Lower chassis assembly		14310	31550	13310	29340
Track frame weld assembly		5415	11940	5315	11720
Swing bearing		720	1590	←	←
Travel motor assembly	TYPE 1	380	840	←	←
	TYPE 2	425	940	←	←
Turning joint		65	140	←	←
Track recoil spring and idler		230	500	←	←
Idler		260	575	←	←
Carrier roller		40	90	←	←
Track roller		80	180	←	←
Track-chain assembly (600 mm standard triple grouser shoe)		2370	5230	←	←
Front attachment assembly (6.5 m boom, 3.2 m arm, 1.62 m ³ SAE heaped bucket)		8430	18580	←	←
6.5 m boom assembly		3180	7010	←	←
3.2 m arm assembly		1480	3260	←	←
1.62 m ³ SAE heaped bucket		1500	3310	←	←
Boom cylinder assembly		370	820	←	←
Arm cylinder assembly		480	1060	←	←
Bucket cylinder assembly		310	680	←	←
Bucket control linkage assembly		370	820	←	←
Sprocket		85	190	←	←









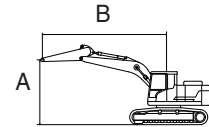





5. LIFTING CAPACITIES

Model	Type	Boom	Arm	Counterweight	Shoe	Wheel	Dozer		Outrigger	
HX380 L	MONO BOOM	Length [mm]	Length [mm]	weight [kg]	width [mm]	width [mm]	Front	Rear	Front	Rear
		6500	3200	6500	800	-	-	-	-	-

·  : Rating over-front

·  : Rating over-side or 360 degree



Lift-point height (A)	Lift-point radius (B)												At max. reach			
	1.5 m (4.9 ft)		3.0 m (9.8 ft)		4.5 m (14.8 ft)		6.0 m (19.7 ft)		7.5 m (24.6 ft)		9.0 m (29.5 ft)		Capacity		Reach	
															m (ft)	
7.5 m (24.6 ft)	kg									*7780	7750			*7050	*7050	7.80
	lb									*17150	17090			*15540	*15540	(25.6)
6.0 m (19.7 ft)	kg									*8000	7630			*6910	5940	8.64
	lb									*17640	16820			*15230	13100	(28.4)
4.5 m (14.8 ft)	kg				*12520	*12520	*9960	*9960	*8720	7350	*8150	5430	*7020	5250	9.17	
	lb				*27600	*27600	*21960	*21960	*19220	16200	*17970	11970	*15480	11570	(30.1)	
3.0 m (9.8 ft)	kg				*16270	14880	*11740	9760	*9660	7010	*8570	5270	*7360	4880	9.42	
	lb				*35870	32800	*25880	21520	*21300	15450	*18890	11620	*16230	10760	(30.9)	
1.5 m (4.9 ft)	kg				*17950	13850	*13310	9190	*10570	6690	8630	5110	*7970	4760	9.43	
	lb				*39570	30530	*29340	20260	*23300	14750	19030	11270	*17570	10490	(30.9)	
0.0 m (0.0 ft)	kg				*18930	13450	*14280	8840	11150	6460	8500	5000	8250	4850	9.19	
	lb				*41730	29650	*31480	19490	24580	14240	18740	11020	18190	10690	(30.1)	
-1.5 m (-4.9 ft)	kg			*12410	*12410	*19660	13390	*14520	8700	11040	6370			8930	5230	8.68
	lb			*27360	*27360	*43340	29520	*32010	19180	24340	14040			19690	11530	(28.5)
-3.0 m (-9.8 ft)	kg	*15020	*15020	*20150	*20150	*18480	13540	*13910	8760	*10750	6430			*10070	6070	7.85
	lb	*33110	*33110	*44420	*44420	*40740	29850	*30670	19310	*23700	14180			*22200	13380	(25.7)
-4.5 m (-14.8 ft)	kg			*21800	*21800	*15940	13930	*11940	9040					*10520	7990	6.57
	lb			*48060	*48060	*35140	30710	*26320	19930					*23190	17610	(21.6)

Note 1. Lifting capacity are based on ISO 10567.

2. Lifting capacity of the HX series does not exceed 75% of tipping load with the machine on firm, level ground or 87% of full hydraulic capacity.

3. The Lift-point is bucket pivot mounting pin on the arm (without bucket mass).

4. *Indicates load limited by hydraulic capacity.

※ Lifting capacities are based upon a standard machine conditions.

Lifting capacities will vary with different work tools, ground conditions and attachments.

The difference between the weight of a work tool attachment must be subtracted.

Consult your Hyundai dealer regarding the lifting capacities for specific work tools and attachments.

▲ Failure to comply to the rated load can cause possible personal injury or property damage.









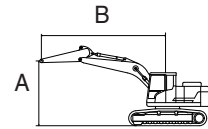





Make adjustments to the rated load as necessary for non-standard configurations.

Model	Type	Boom	Arm	Counterweight	Shoe	Wheel	Dozer		Outrigger	
HX380 L	MONO BOOM	Length [mm]	Length [mm]	weight [kg]	width [mm]	width [mm]	Front	Rear	Front	Rear
		6500	3200	6500	600	-	-	-	-	-

•  : Rating over-front

•  : Rating over-side or 360 degree











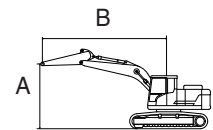

Lift-point height (A)		Lift-point radius (B)												At max. reach		
		1.5 m (4.9 ft)		3.0 m (9.8 ft)		4.5 m (14.8 ft)		6.0 m (19.7 ft)		7.5 m (24.6 ft)		9.0 m (29.5 ft)		Capacity		Reach
																m (ft)
7.5 m (24.6 ft)	kg									*7780	7580			*7050	*7050	7.80
	lb									*17150	16710			*15540	*15540	(25.6)
6.0 m (19.7 ft)	kg									*8000	7470			*6910	5800	8.64
	lb									*17640	16470			*15230	12790	(28.4)
4.5 m (14.8 ft)	kg					*12520	*12520	*9960	*9960	*8720	7190	*8150	5300	*7020	5120	9.17
	lb					*27600	*27600	*21960	*21960	*19220	15850	*17970	11680	*15480	11290	(30.1)
3.0 m (9.8 ft)	kg					*16270	14560	*11740	9540	*9660	6840	*8570	5140	*7360	4760	9.42
	lb					*35870	32100	*25880	21030	*21300	15080	*18890	11330	*16230	10490	(30.9)
1.5 m (4.9 ft)	kg					*17950	13530	*13310	8970	*10570	6520	8410	4980	7830	4630	9.43
	lb					*39570	29830	*29340	19780	*23300	14370	18540	10980	17260	10210	(30.9)
0.0 m (0.0 ft)	kg					*18930	13120	*14280	8620	10880	6300	8290	4860	8040	4720	9.19
	lb					*41730	28920	*31480	19000	23990	13890	18280	10710	17730	10410	(30.1)
-1.5 m (-4.9 ft)	kg			*12410	*12410	*19660	13060	*14520	8480	10770	6200			8710	5090	8.68
	lb			*27360	*27360	*43340	28790	*32010	18700	23740	13670			19200	11220	(28.5)
-3.0 m (-9.8 ft)	kg	*15020	*15020	*20150	*20150	*18480	13220	*13910	8540	*10750	6260			*10070	5910	7.85
	lb	*33110	*33110	*44420	*44420	*40740	29150	*30670	18830	*23700	13800			*22200	13030	(25.7)
-4.5 m (-14.8 ft)	kg			*21800	*21800	*15940	13600	*11940	8820					*10520	7790	6.57
	lb			*48060	*48060	*35140	29980	*26320	19440					*23190	17170	(21.6)

Model	Type	Boom	Arm	Counterweight	Shoe	Wheel	Dozer		Outrigger	
HX380 L	MONO BOOM	Length [mm]	Length [mm]	weight [kg]	width [mm]	width [mm]	Front	Rear	Front	Rear
		6500	2500	6500	600	-	-	-	-	-

·  : Rating over-front

·  : Rating over-side or 360 degree



Lift-point height (A)	Lift-point radius (B)								At max. reach			
	3.0 m (9.8 ft)		4.5 m (14.8 ft)		6.0 m (19.7 ft)		7.5 m (24.6 ft)		Capacity		Reach	
											m (ft)	
7.5 m (24.6 ft)	kg									*8970	7990	7.16
	lb									*19780	17610	(23.5)
6.0 m (19.7 ft)	kg				*9570	*9570	*8910	7330	*8920	6420	8.08	
	lb				*21100	*21100	*19640	16160	*19670	14150	(26.5)	
4.5 m (14.8 ft)	kg			*14450	*14450	*11020	10010	*9500	7100	*9030	5620	8.64
	lb			*31860	*31860	*24290	22070	*20940	15650	*19910	12390	(28.3)
3.0 m (9.8 ft)	kg				*12690	9390	*10330	6800	8710	5210	8.91	
	lb				*27980	20700	*22770	14990	19200	11490	(29.2)	
1.5 m (4.9 ft)	kg				*14020	8920	*11090	6530	8570	5090	8.91	
	lb				*30910	19670	*24450	14400	18890	11220	(29.2)	
0.0 m (0.0 ft)	kg			*14720	13240	*14660	8670	10940	6370	8870	5240	8.66
	lb			*32450	29190	*32320	19110	24120	14040	19550	11550	(28.4)
-1.5 m (-4.9 ft)	kg			*19240	13310	*14510	8630	10910	6340	9750	5730	8.12
	lb			*42420	29340	*31990	19030	24050	13980	21500	12630	(26.6)
-3.0 m (-9.8 ft)	kg	*22860	*22860	*17520	13550	*13390	8770			*10540	6850	7.22
	lb	*50400	*50400	*38620	29870	*29520	19330			*23240	15100	(23.7)
-4.5 m (-14.8 ft)	kg			*14070	14050					*10490	9670	5.80
	lb			*31020	30970					*23130	21320	(19.0)

Model	Type	Boom	Arm	Counterweight	Shoe	Wheel	Dozer		Outrigger	
HX380 L	MONO BOOM	Length [mm]	Length [mm]	weight [kg]	width [mm]	width [mm]	Front	Rear	Front	Rear
		6500	3900	6500	600	-	-	-	-	-



: Rating over-front



: Rating over-side or 360 degree

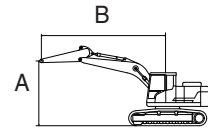









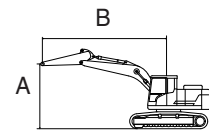

Lift-point height (A)	Lift-point radius (B)												At max. reach			
	1.5 m (4.9 ft)		3.0 m (9.8 ft)		4.5 m (14.8 ft)		6.0 m (19.7 ft)		7.5 m (24.6 ft)		9.0 m (29.5 ft)		Capacity		Reach	
															m (ft)	
9.0 m (29.5 ft)	kg													*5580	*5580	7.43
	lb													*12300	*12300	(24.4)
7.5 m (24.6 ft)	kg							*6800	*6800					*5230	*5230	8.59
	lb							*14990	*14990					*11530	*11530	(28.2)
6.0 m (19.7 ft)	kg							*7180	*7180	*6490	5560	*5130	*5130	9.36		
	lb							*15830	*15830	*14310	12260	*11310	*11310	(30.7)		
4.5 m (14.8 ft)	kg						*8930	*8930	*7990	7370	*7510	5430	*5200	4610	9.85	
	lb						*19690	*19690	*17610	16250	*16560	11970	*11460	10160	(32.3)	
3.0 m (9.8 ft)	kg			*14530	*14530	*10820	9840	*9040	7000	*8060	5240	*5410	4310	10.08		
	lb			*32030	*32030	*23850	21690	*19930	15430	*17770	11550	*11930	9500	(33.1)		
1.5 m (4.9 ft)	kg			*17770	13980	*12620	9200	*10080	6640	8480	5040	*5810	4190	10.09		
	lb			*39180	30820	*27820	20280	*22220	14640	18700	11110	*12810	9240	(33.1)		
0.0 m (0.0 ft)	kg			*7060	*7060	*19500	13320	*13900	8750	*10910	6370	8310	4880	*6450	4260	9.87
	lb			*15560	*15560	*42990	29370	*30640	19290	*24050	14040	18320	10760	*14220	9390	(32.4)
-1.5 m (-4.9 ft)	kg	*7760	*7760	*11450	*11450	*19910	13080	*14490	8520	10770	6210	8220	4800	*7490	4530	9.39
	lb	*17110	*17110	*25240	*25240	*43890	28840	*31940	18780	23740	13690	18120	10580	*16510	9990	(30.8)
-3.0 m (-9.8 ft)	kg	*12390	*12390	*16990	*16990	*19280	13120	*14310	8480	10750	6180			8760	5120	8.63
	lb	*27320	*27320	*37460	*37460	*42510	28920	*31550	18700	23700	13620			19310	11290	(28.3)
-4.5 m (-14.8 ft)	kg	*17960	*17960	*24770	*24770	*17460	13390	*13090	8640					*9810	6360	7.50
	lb	*39590	*39590	*54610	*54610	*38490	29520	*28860	19050					*21630	14020	(24.6)
-6.0 m (-19.7 ft)	kg			*18940	*18940	*13630	*13630							*10220	9650	5.76
	lb			*41760	*41760	*30050	*30050							*22530	21270	(18.9)

Model	Type	Boom	Arm	Counterweight	Shoe	Wheel	Dozer		Outrigger	
HX380 L	MONO BOOM	Length [mm]	Length [mm]	weight [kg]	width [mm]	width [mm]	Front	Rear	Front	Rear
		6150	2500	6500	600	-	-	-	-	-

·  : Rating over-front

·  : Rating over-side or 360 degree











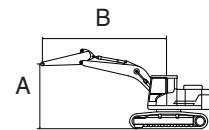





Lift-point height (A)		Lift-point radius (B)								At max. reach		
		3.0 m (9.8 ft)		4.5 m (14.8 ft)		6.0 m (19.7 ft)		7.5 m (24.6 ft)		Capacity		Reach
												m (ft)
7.5 m (24.6 ft)	kg					*9230	*9230			*9460	8940	6.71
	lb					*20350	*20350			*20860	19710	(22.0)
6.0 m (19.7 ft)	kg					*9720	*9720	*9350	7360	*9400	7030	7.69
	lb					*21430	*21430	*20610	16230	*20720	15500	(25.2)
4.5 m (14.8 ft)	kg			*14000	*14000	*11060	10180	*9770	7180	*9530	6100	8.27
	lb			*30860	*30860	*24380	22440	*21540	15830	*21010	13450	(27.1)
3.0 m (9.8 ft)	kg					*12720	9610	*10540	6910	9360	5640	8.55
	lb					*28040	21190	*23240	15230	20640	12430	(28.1)
1.5 m (4.9 ft)	kg					*14120	9140	11260	6670	9210	5510	8.56
	lb					*31130	20150	24820	14700	20300	12150	(28.1)
0.0 m (0.0 ft)	kg			*20360	13530	*14840	8880	11090	6510	9570	5680	8.29
	lb			*44890	29830	*32720	19580	24450	14350	21100	12520	(27.2)
-1.5 m (-4.9 ft)	kg	*14530	*14530	*19660	13560	*14700	8820	11080	6510	10630	6270	7.72
	lb	*32030	*32030	*43340	29890	*32410	19440	24430	14350	23440	13820	(25.3)
-3.0 m (-9.8 ft)	kg	*24010	*24010	*17760	13800	*13350	8980			*11280	7650	6.77
	lb	*52930	*52930	*39150	30420	*29430	19800			*24870	16870	(22.2)
-4.5 m (-14.8 ft)	kg			*13520	*13520					*11150	*11150	5.23
	lb			*29810	*29810					*24580	*24580	(17.2)

Model	Type	Boom	Arm	Counterweight	Shoe	Wheel	Dozer		Outrigger	
HX380 NL	MONO BOOM	Length [mm]	Length [mm]	weight [kg]	width [mm]	width [mm]	Front	Rear	Front	Rear
		6500	3200	6500	600	-	-	-	-	-

•  : Rating over-front

•  : Rating over-side or 360 degree



Lift-point height (A)	Lift-point radius (B)												At max. reach		
	1.5 m (4.9 ft)		3.0 m (9.8 ft)		4.5 m (14.8 ft)		6.0 m (19.7 ft)		7.5 m (24.6 ft)		9.0 m (29.5 ft)		Capacity		Reach
															m (ft)
7.5 m (24.6 ft)	kg								*7780	6560			*7050	6100	7.80
	lb								*17150	14460			*15540	13450	(25.6)
6.0 m (19.7 ft)	kg								*8000	6450			*6910	4980	8.64
	lb								*17640	14220			*15230	10980	(28.4)
4.5 m (14.8 ft)	kg			*12520	*12520	*9960	8780	*8720	6180	*8150	4530	*7020	4370	9.17	
	lb			*27600	*27600	*21960	19360	*19220	13620	*17970	9990	*15480	9630	(30.1)	
3.0 m (9.8 ft)	kg			*16270	12200	*11740	8130	*9660	5840	8570	4370	*7360	4040	9.42	
	lb			*35870	26900	*25880	17920	*21300	12870	18890	9630	*16230	8910	(30.9)	
1.5 m (4.9 ft)	kg			*17950	11230	*13310	7580	*10570	5530	8390	4210	7810	3920	9.43	
	lb			*39570	24760	*29340	16710	*23300	12190	18500	9280	17220	8640	(30.9)	
0.0 m (0.0 ft)	kg			*18930	10840	*14280	7240	10850	5320	8260	4100	8020	3990	9.19	
	lb			*41730	23900	*31480	15960	23920	11730	18210	9040	17680	8800	(30.1)	
-1.5 m (-4.9 ft)	kg		*12410	*12410	*19660	10790	*14520	7100	10730	5220		8680	4290	8.68	
	lb		*27360	*27360	*43340	23790	*32010	15650	23660	11510		19140	9460	(28.5)	
-3.0 m (-9.8 ft)	kg	*15020	*15020	*20150	*20150	*18480	10930	*13910	7160	*10750	5280	*10070	4990	7.85	
	lb	*33110	*33110	*44420	*44420	*40740	24100	*30670	15790	*23700	11640	*22200	11000	(25.7)	
-4.5 m (-14.8 ft)	kg		*21800	*21800	*15940	11300	*11940	7430				*10520	6590	6.57	
	lb		*48060	*48060	*35140	24910	*26320	16380				*23190	14530	(21.6)	

Note 1. Lifting capacity are based on ISO 10567.

2. Lifting capacity of the HX series does not exceed 75% of tipping load with the machine on firm, level ground or 87% of full hydraulic capacity.

3. The Lift-point is bucket pivot mounting pin on the arm (without bucket mass).

4. *Indicates load limited by hydraulic capacity.

※ Lifting capacities are based upon a standard machine conditions.

Lifting capacities will vary with different work tools, ground conditions and attachments.

The difference between the weight of a work tool attachment must be subtracted.

Consult your Hyundai dealer regarding the lifting capacities for specific work tools and attachments.

▲ Failure to comply to the rated load can cause possible personal injury or property damage.









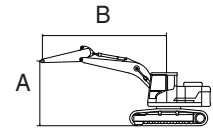

Make adjustments to the rated load as necessary for non-standard configurations.

Model	Type	Boom	Arm	Counterweight	Shoe	Wheel	Dozer		Outrigger	
HX380 NL	MONO BOOM	Length [mm]	Length [mm]	weight [kg]	width [mm]	width [mm]	Front	Rear	Front	Rear
		6500	2500	6500	600	-	-	-	-	-

·  : Rating over-front

·  : Rating over-side or 360 degree











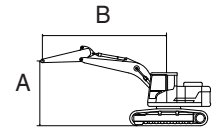

Lift-point height (A)		Lift-point radius (B)								At max. reach		
		3.0 m (9.8 ft)		4.5 m (14.8 ft)		6.0 m (19.7 ft)		7.5 m (24.6 ft)		Capacity		Reach
												m (ft)
7.5 m (24.6 ft)	kg									*8970	6910	7.16
	lb									*19780	15230	(23.5)
6.0 m (19.7 ft)	kg				*9570	9120	*8910	6320	*8920	5520	8.08	
	lb				*21100	20110	*19640	13930	*19670	12170	(26.5)	
4.5 m (14.8 ft)	kg			*14450	13090	*11020	8580	*9500	6090	*9030	4810	8.64
	lb			*31860	28860	*24290	18920	*20940	13430	*19910	10600	(28.3)
3.0 m (9.8 ft)	kg				*12690	7980	*10330	5800	8680	4440	8.91	
	lb				*27980	17590	*22770	12790	19140	9790	(29.2)	
1.5 m (4.9 ft)	kg				*14020	7530	*11090	5540	8540	4320	8.91	
	lb				*30910	16600	*24450	12210	18830	9520	(29.2)	
0.0 m (0.0 ft)	kg			*14720	10970	*14660	7290	10910	5390	8840	4440	8.66
	lb			*32450	24180	*32320	16070	24050	11880	19490	9790	(28.4)
-1.5 m (-4.9 ft)	kg			*19240	11030	*14510	7250	10880	5360	9720	4860	8.12
	lb			*42420	24320	*31990	15980	23990	11820	21430	10710	(26.6)
-3.0 m (-9.8 ft)	kg	*22860	22530	*17520	11260	*13390	7380			*10540	5810	7.22
	lb	*50400	49670	*38620	24820	*29520	16270			*23240	12810	(23.7)
-4.5 m (-14.8 ft)	kg			*14070	11730					*10490	8190	5.80
	lb			*31020	25860					*23130	18060	(19.0)

Model	Type	Boom	Arm	Counterweight	Shoe	Wheel	Dozer		Outrigger	
HX380 NL	MONO BOOM	Length [mm]	Length [mm]	weight [kg]	width [mm]	width [mm]	Front	Rear	Front	Rear
		6150	2500	6500	600	-	-	-	-	-

·  : Rating over-front

·  : Rating over-side or 360 degree



Lift-point height (A)		Lift-point radius (B)								At max. reach		
		3.0 m (9.8 ft)		4.5 m (14.8 ft)		6.0 m (19.7 ft)		7.5 m (24.6 ft)		Capacity		Reach
												m (ft)
7.5 m (24.6 ft)	kg					*9230	*9230			*9460	7740	6.71
	lb					*20350	*20350			*20860	17060	(22.0)
6.0 m (19.7 ft)	kg					*9720	9230	*9350	6350	*9400	6070	7.69
	lb					*21430	20350	*20610	14000	*20720	13380	(25.2)
4.5 m (14.8 ft)	kg			*14000	13500	*11060	8750	*9770	6180	*9530	5230	8.27
	lb			*30860	29760	*24380	19290	*21540	13620	*21010	11530	(27.1)
3.0 m (9.8 ft)	kg					*12720	8190	*10540	5920	9340	4820	8.55
	lb					*28040	18060	*23240	13050	20590	10630	(28.1)
1.5 m (4.9 ft)	kg					*14120	7740	11230	5680	9190	4690	8.56
	lb					*31130	17060	24760	12520	20260	10340	(28.1)
0.0 m (0.0 ft)	kg			*20360	11240	*14840	7490	11060	5530	9540	4830	8.29
	lb			*44890	24780	*32720	16510	24380	12190	21030	10650	(27.2)
-1.5 m (-4.9 ft)	kg	*14530	*14530	*19660	11270	*14700	7440	11050	5520	10600	5330	7.72
	lb	*32030	*32030	*43340	24850	*32410	16400	24360	12170	23370	11750	(25.3)
-3.0 m (-9.8 ft)	kg	*24010	22810	*17760	11500	*13350	7590			*11280	6500	6.77
	lb	*52930	50290	*39150	25350	*29430	16730			*24870	14330	(22.2)
-4.5 m (-14.8 ft)	kg			*13520	12040					*11150	9730	5.23
	lb			*29810	26540					*24580	21450	(17.2)

6. BUCKET SELECTION GUIDE

1) GENERAL BUCKET

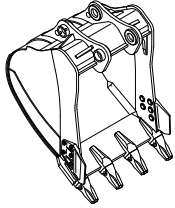
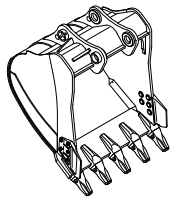
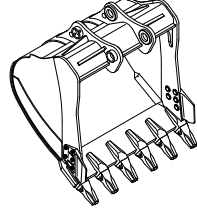
		
1.46 m ³ SAE heaped bucket	※ 1.62 m ³ , 1.90 m ³ , 2.10 m ³ SAE heaped bucket	2.32 m ³ SAE heaped bucket

Capacity		Width	Weight	Recommendation			
				6.5 m (21' 4") boom			6.15 m (20' 2") boom
SAE heaped	CECE heaped			2.5 m arm (8' 2")	3.2 m arm (10' 6")	3.9 m arm (12' 10")	2.5 m arm (8' 2")
1.46 m ³ (1.91 yd ³)	1.28 m ³ (1.67 yd ³)	1370 mm (54")	1400 kg (3090 lb)	○	○	⊙	○
※ 1.62 m ³ (2.12 yd ³)	1.42 m ³ (1.86 yd ³)	1480 mm (58")	1500 kg (3310 lb)	○	⊙	⊙	○
1.90 m ³ (2.49 yd ³)	1.65 m ³ (2.16 yd ³)	1665 mm (66")	1610 kg (2450 lb)	⊙	●	●	⊙
2.10 m ³ (2.75 yd ³)	1.84 m ³ (2.41 yd ³)	1800 mm (71")	1690 kg (3730 lb)	●	●	●	⊙
2.32 m ³ (3.03 yd ³)	2.02 m ³ (2.64 yd ³)	1950 mm (77")	1800 kg (3970 lb)	●	●		●

※ : Standard bucket

○ Applicable for materials with density of 2000 kg/m³ (3370 lb/yd³) or less

⊙ Applicable for materials with density of 1600 kg/m³ (2700 lb/yd³) or less

● Applicable for materials with density of 1100 kg/m³ (1850 lb/yd³) or less

※ These recommendations are for general conditions and average use.

Work tools and ground conditions have effects on machine performance.

Select an optimum combination according to the working conditions and the type of work that is being done.

Consult your Hyundai dealer for information on selecting the correct boom-arm-bucket combination.

2) HEAVY DUTY AND ROCK-HEAVY DUTY BUCKET

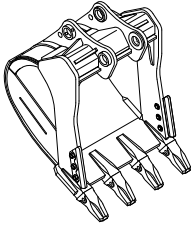
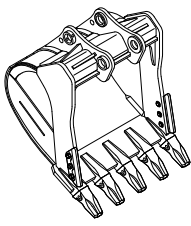
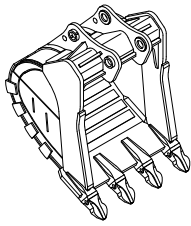
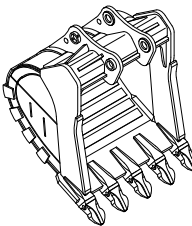
			
◆ 1.46 m ³ SAE heaped bucket	◆ 1.62 m ³ , 1.90 m ³ , 2.10 m ³ SAE heaped bucket	◆ 1.46 m ³ SAE heaped bucket	◆ 1.62 m ³ , 1.90 m ³ SAE heaped bucket

Capacity		Width	Weight	Recommendation			
				6.5 m (21' 4") boom			6.15 m (20' 2") boom
SAE heaped	CECE heaped			2.5 m arm (8' 2")	3.2 m arm (10' 6")	3.9 m arm (12' 10")	2.5 m arm (8' 2")
◆ 1.46 m ³ (1.91 yd ³)	1.28 m ³ (1.67 yd ³)	1370 mm (54")	1560 kg (3440 lb)	○	○	⊙	○
◆ 1.62 m ³ (2.12 yd ³)	1.42 m ³ (1.86 yd ³)	1480 mm (58")	1660 kg (3660 lb)	○	⊙	●	○
◆ 1.90 m ³ (2.49 yd ³)	1.65 m ³ (2.16 yd ³)	1665 mm (66")	1790 kg (3950 lb)	⊙	●	●	⊙
◆ 2.10 m ³ (2.75 yd ³)	1.84 m ³ (2.41 yd ³)	1800 mm (71")	1880 kg (4140 lb)	●	●		⊙
◆ 1.46 m ³ (1.91 yd ³)	1.28 m ³ (1.67 yd ³)	1370 mm (54")	1750 kg (3860 lb)	○	○	⊙	○
◆ 1.62 m ³ (2.12 yd ³)	1.42 m ³ (1.86 yd ³)	1480 mm (58")	1850 kg (4080 lb)	⊙	⊙	●	○
◆ 1.90 m ³ (2.49 yd ³)	1.65 m ³ (2.16 yd ³)	1665 mm (66")	1990 kg (4390 lb)	●	●	●	⊙

◆ : Heavy duty bucket

◆ : Rock-heavy duty bucket

○ Applicable for materials with density of 2000 kg/m³ (3370 lb/yd³) or less

⊙ Applicable for materials with density of 1600 kg/m³ (2700 lb/yd³) or less

● Applicable for materials with density of 1100 kg/m³ (1850 lb/yd³) or less

7. UNDERCARRIAGE

1) TRACKS

X-leg type center frame is integrally welded with reinforced box-section track frames. The design includes dry tracks, lubricated rollers, idlers, sprockets, hydraulic track adjusters with shock absorbing springs and assembled track-type tractor shoes with triple grousers.

2) TYPES OF SHOES

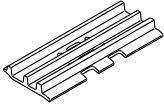
Model	Shapes		Triple grouser				
							
HX380 L	Shoe width	mm (in)	600 (24)	700 (28)	750 (30)	800 (32)	900 (36)
	Operating weight	kg (lb)	38920 (85800)	39370 (86800)	39595 (87290)	39820 (87790)	40270 (88780)
	Ground pressure	kgf/cm ² (psi)	0.70 (9.95)	0.61 (8.67)	0.57 (8.11)	0.54 (7.68)	0.48 (6.83)
	Overall width	mm (ft-in)	3340 (10' 11")	3440 (11' 3")	3490 (11' 5")	3540 (11' 7")	3640 (11' 11")
HX380 NL	Shoe width	mm (in)	600 (24)	-	-	-	-
	Operating weight	kg (lb)	38820 (85580)	-	-	-	-
	Ground pressure	kgf/cm ² (psi)	0.70 (9.95)	-	-	-	-
	Overall width	mm (ft-in)	2990 (9' 10")	-	-	-	-

3) NUMBER OF ROLLERS AND SHOES ON EACH SIDE

Item	Quantity
Carrier rollers	2 EA
Track rollers	9 EA
Track shoes	51 EA

4) SELECTION OF TRACK SHOE

Suitable track shoes should be selected according to operating conditions.

Method of selecting shoes

Confirm the category from the list of applications in **table 2**, then use **table 1** to select the shoe. Wide shoes (categories B and C) have limitations on applications. Before using wide shoes, check the precautions, then investigate and study the operating conditions to confirm if these shoes are suitable.

Select the narrowest shoe possible to meet the required flotation and ground pressure. Application of wider shoes than recommendations will cause unexpected problem such as bending of shoes, crack of link, breakage of pin, loosening of shoe bolts and the other various problems.

※ **Table 1**

Track shoe	Specification	Category
600 mm triple grouser	Standard	A
700 mm triple grouser	Option	B
750 mm triple grouser	Option	B
800 mm triple grouser	Option	C
900 mm triple grouser	Option	C

※ **Table 2**

Category	Applications	Applications
A	Rocky ground, river beds, normal soil	<ul style="list-style-type: none"> Travel at low speed on rough ground with large obstacles such as boulders or fallen trees
B	Normal soil, soft ground	<ul style="list-style-type: none"> These shoes cannot be used on rough ground with large obstacles such as boulders or fallen trees Travel at high speed only on flat ground Travel slowly at low speed if it is impossible to avoid going over obstacles
C	Extremely soft ground (swampy ground)	<ul style="list-style-type: none"> Use the shoes only in the conditions that the machine sinks and it is impossible to use the shoes of category A or B These shoes cannot be used on rough ground with large obstacles such as boulders or fallen trees Travel at high speed only on flat ground Travel slowly at low speed if it is impossible to avoid going over obstacles

8. SPECIFICATIONS FOR MAJOR COMPONENTS

1) ENGINE

Item	Specification
Model	Cummins QSL9
Type	4-cycle turbocharged charger air cooled diesel engine
Cooling method	Water cooling
Number of cylinders and arrangement	6 cylinders, in-line
Firing order	1-5-3-6-2-4
Combustion chamber type	Direct injection type
Cylinder bore × stroke	114 × 145 mm (4.49" × 5.69")
Piston displacement	8900 cc (543 cu in)
Compression ratio	16.7 : 1
Rated net horse power (SAE J1349)	344 Hp at 1650 rpm (257 kW at 1650 rpm)
Rated gross horse power (SAE J1995)	359 Hp at 1650 rpm (267 kW at 1650 rpm)
Maximum torque	166 kgf · m (1186 lbf · ft) at 1500 rpm
Engine oil quantity	30 ℓ (7.9 U.S. gal)
Wet weight	708 kg (1560 lb)
Low idling speed	900 ± 100 rpm
High idling speed	1700 + 50 rpm
Rated fuel consumption	155 g/Hp · hr at 1650 rpm
Starting motor	Denso (24V-7.8 kW)
Alternator	Denso 24V-95A
Battery	2 × 12V × 160Ah

2) MAIN PUMP

Item	Specification
Type	Variable displacement tandem axis piston pumps
Capacity	2 × 175 cc/rev
Maximum pressure	330 kgf/cm ² (4690 psi) [360 kgf/cm ² (5120 psi)]
Rated oil flow	2 × 288.8 ℓ /min (76.3 U.S. gpm / 63.5 U.K. gpm)
Rated speed	1650 rpm

[]: Power boost

3) GEAR PUMP

Item	Specification
Type	Fixed displacement gear pump single stage
Capacity	15cc/rev
Maximum pressure	40 kgf/cm ² (570 psi)
Rated oil flow	24.75 ℓ /min (6.5 U.S. gpm/5.4 U.K. gpm)

4) MAIN CONTROL VALVE

Item	Specification
Type	9 spools
Operating method	Hydraulic pilot system
Main relief valve pressure	330 kgf/cm ² (4690 psi) [360 kgf/cm ² (5120 psi)]
Overload relief valve pressure	390 kgf/cm ² (5550 psi)

[]: Power boost

5) SWING MOTOR

Item	Specification	
Machine serial No.	-#0465	#0466-
Type	Axial piston motor	
Capacity	233 cc/rev	240 cc/rev
Relief pressure	290 kgf/cm ² (4120 psi)	
Braking system	Automatic, spring applied hydraulic released	
Braking torque	107 kgf · m (773 lbf · ft)	134 kgf · m (969 lbf · ft)
Brake release pressure	30~50 kgf/cm ² (427~711 psi)	26 kgf/cm ² (370 psi)
Reduction gear type	2 - stage planetary	

6) TRAVEL MOTOR

Item	Specification	
Type	Variable displacement axial piston motor	
Relief pressure	370 kgf/cm ² (5260 psi)	*360 kgf/cm ² (5120 psi)
Capacity (max / min)	185/114 cc/rev	
Reduction gear type	3-stage planetary	
Braking system	Automatic, spring applied hydraulic released	
Brake release pressure	10.6 kgf/cm ² (151 psi)	*8.9 kgf/cm ² (127 psi)
Braking torque	57.1 kgf · m (413 lbf · ft)	*49.0 kgf · m (354 lbf · ft)

* : TRAVEL MOTOR (TYPE 2)

7) CYLINDER

Item		Specification
Boom cylinder	Bore dia × Rod dia × Stroke	∅ 160 × ∅ 110 × 1500 mm
	Cushion	Extend only
Arm cylinder	Bore dia × Rod dia × Stroke	∅ 170 × ∅ 120 × 1760 mm
	Cushion	Extend and retract
Bucket cylinder	Bore dia × Rod dia × Stroke	∅ 150 × ∅ 105 × 1295 mm
	Cushion	Extend only

※ Discoloration of cylinder rod can occur when the friction reduction additive of lubrication oil spreads on the rod surface.

※ Discoloration does not cause any harmful effect on the cylinder performance.

8) SHOE

Item		Width	Ground pressure	Link quantity	Overall width
HX380 L	Standard	600 mm (24")	0.70 kgf/cm ² (9.95 psi)	51	3340 mm (10' 11")
	Option	700 mm (28")	0.61 kgf/cm ² (8.67 psi)	51	3440 mm (11' 3")
		750 mm (30")	0.57 kgf/cm ² (8.11 psi)	51	3490 mm (11' 5")
		800 mm (32")	0.54 kgf/cm ² (7.68 psi)	51	3540 mm (11' 7")
		900 mm (36")	0.48 kgf/cm ² (6.83 psi)	51	3640 mm (11' 11")
HX380 NL	Standard	600 mm (24")	0.70 kgf/cm ² (9.95 psi)	51	2990 mm (9' 10")

9) BUCKET

Item		Capacity		Tooth quantity	Width	
		SAE heaped	CECE heaped			
HX380L HX380NL	Standard	1.62 m ³ (2.12 yd ³)	1.42 m ³ (1.86 yd ³)	5	1480 mm (58")	
			1.46 m ³ (1.91 yd ³)	1.28 m ³ (1.67 yd ³)	4	1370 mm (54")
			1.90 m ³ (2.49 yd ³)	1.65 m ³ (2.16 yd ³)	5	1665 mm (66")
			2.10 m ³ (2.75 yd ³)	1.84 m ³ (2.41 yd ³)	5	1800 mm (71")
			2.32 m ³ (3.03 yd ³)	2.02 m ³ (2.64 yd ³)	6	1950 mm (77")
			◆1.46 m ³ (1.91 yd ³)	1.28 m ³ (1.67 yd ³)	4	1370 mm (54")
			◆1.62 m ³ (2.12 yd ³)	1.42 m ³ (1.86 yd ³)	5	1480 mm (58")
			◆1.90 m ³ (2.49 yd ³)	1.65 m ³ (2.16 yd ³)	5	1665 mm (66")
			◆2.10 m ³ (2.75 yd ³)	1.84 m ³ (2.41 yd ³)	5	1800 mm (71")
			◆1.46 m ³ (1.91 yd ³)	1.28 m ³ (1.67 yd ³)	4	1370 mm (54")
			◆1.62 m ³ (2.12 yd ³)	1.42 m ³ (1.86 yd ³)	5	1480 mm (58")
			◆1.90 m ³ (2.49 yd ³)	1.65 m ³ (2.16 yd ³)	5	1665 mm (66")

◆ : Heavy duty bucket

◆ : Rock-heavy duty bucket

9. RECOMMENDED OILS

HYUNDAI genuine lubricating oils have been developed to offer the best performance and service life for your equipment. These oils have been tested according to the specifications of HYUNDAI and, therefore, will meet the highest safety and quality requirements.

We recommend that you use only HYUNDAI genuine lubricating oils and grease officially approved by HYUNDAI.

Service point	Kind of fluid	Capacity ℓ (U.S. gal)	Ambient temperature °C (°F)						
			-50 (-58)	-30 (-22)	-20 (-4)	-10 (14)	0 (32)	10 (50)	20 (68)
Engine oil pan	Engine oil	31.7 (8.4)	★SAE 5W-40						
			SAE 30						
			SAE 10W						
			SAE 10W-30						
			SAE 15W-40						
DEF/ AdBlue® tank	Mixture of urea and deionized water	42.5 (11.2)	ISO 22241, High-purity urea + deionized water (32.5:67.5)						
Swing drive	Gear oil	8.0 (2.1)	★SAE 75W-90						
Final drive		TYPE 1 : 4.3 (1.1) × 2 TYPE 2 : 5.5 (1.5) × 2	SAE 80W-90						
Hydraulic tank	Hydraulic oil	Tank : 210 (55.5) System : 414 (109)	★ISO VG 15						
			ISO VG 32						
			ISO VG 46, HBHO VG 46★ ³						
			ISO VG 68						
Fuel tank	Diesel fuel★ ¹	600 (159)	★ASTM D975 NO.1						
			ASTM D975 NO.2						
Fitting (grease nipple)	Grease	As required	★NLGI NO.1						
			NLGI NO.2						
Radiator (reservoir tank)	Mixture of antifreeze and soft water★ ²	55 (14.5)	Ethylene glycol base permanent type (50 : 50)						
			★Ethylene glycol base permanent type (60 : 40)						

SAE : Society of Automotive Engineers

API : American Petroleum Institute

ISO : International Organization for Standardization

NLGI : National Lubricating Grease Institute

ASTM : American Society of Testing and Material

UTTO : Universal Tractor Transmission Oil

DEF : Diesel Exhaust Fluid, DEF compatible with AdBlue®

★ : Cold region

Russia, CIS, Mongolia

★¹ : Ultra low sulfur diesel
- sulfur content ≤ 15 ppm

★² : Soft water

City water or distilled water

★³ : Hyundai Bio Hydraulic Oil

- For more information, contact HYUNDAI dealers.

※ Using any lubricating oils other than HYUNDAI genuine products may lead to a deterioration of performance and cause damage to major components.

※ Do not mix HYUNDAI genuine oil with any other lubricating oil as it may result in damage to the systems of major components.

※ Do not use any engine oil other than that specified above, as it may clog the diesel particulate filter(DPF).

※ For HYUNDAI genuine lubricating oils and grease for use in regions with extremely low temperatures, please contact HYUNDAI dealers.