

SECTION 2 STRUCTURE AND FUNCTION

Group 1 Pump Device	2-1
Group 2 Main Control Valve	2-22
Group 3 Swing Device (machine serial no. : -#0025)	2-56
Swing Device (machine serial no. : #0026-)	2-67-1
Group 4 Travel Device (type 1)	2-68
Travel Device (type 2, machine serial no. : #0190-)	2-80-1
Group 5 RCV Lever	2-81
Group 6 RCV Pedal	2-88

SECTION 2 STRUCTURE AND FUNCTION

GROUP 1 PUMP DEVICE

1. STRUCTURE

The pump device consists of main pump, regulator and gear pump.

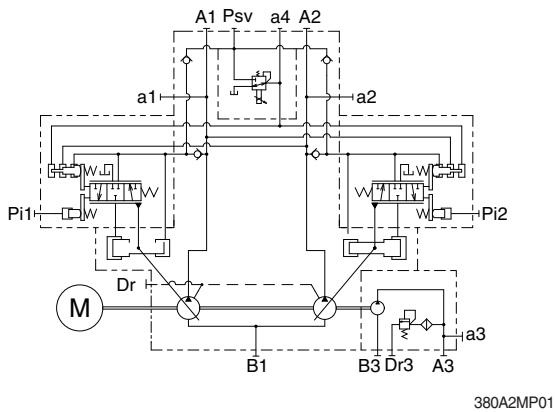
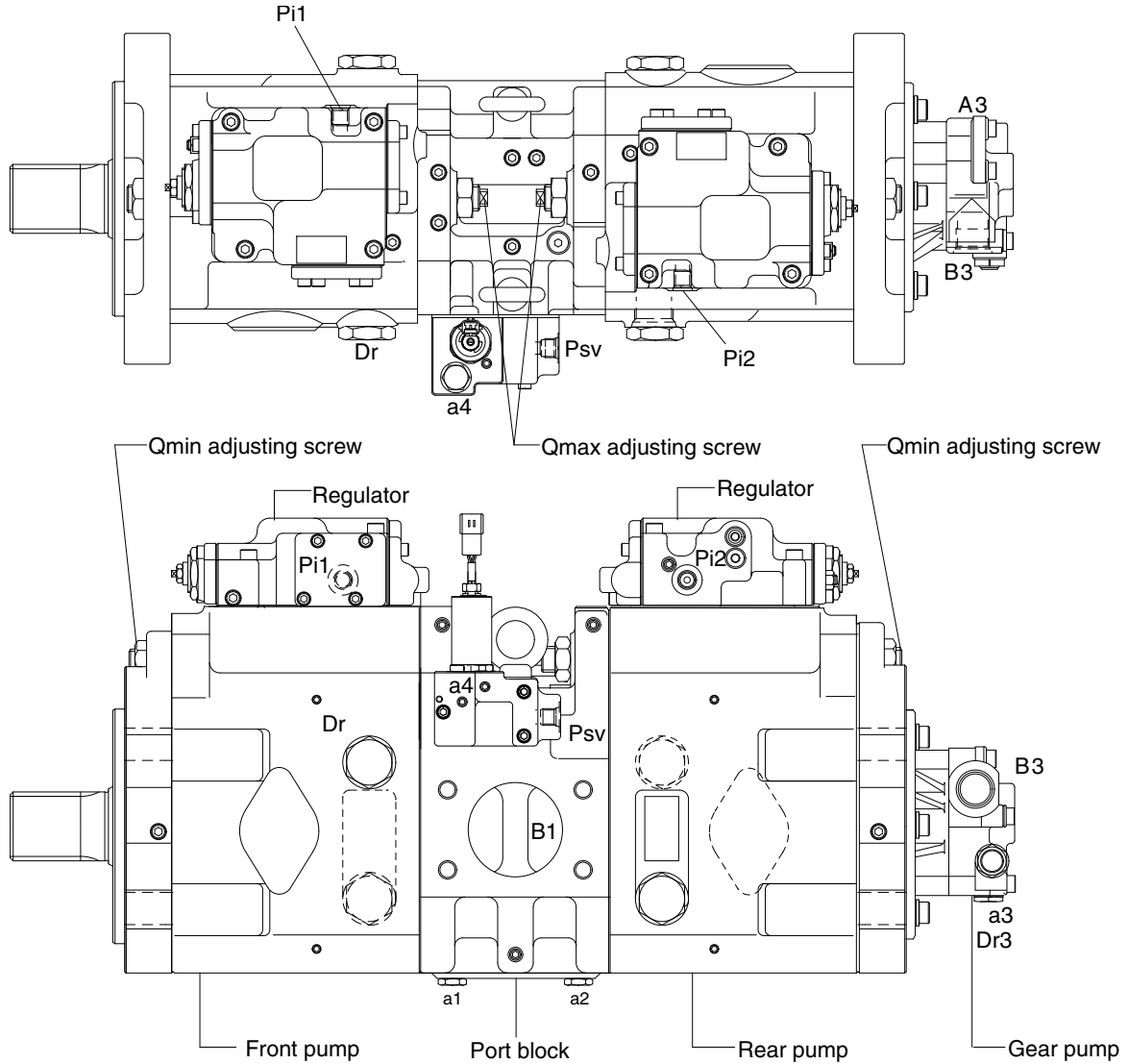

Port	Port name	Port size
A1, 2	Delivery port	SAE6000 psi 1"
B1	Suction port	SAE2000 psi 3"
Dr	Drain port	PF 3/4 - 23
Pi1, i2	Pilot port	PF 1/4 - 15
Psv	Servo assist port	PF 1/4 - 15
a1, 2, 4	Gauge port	PF 1/4 - 15
a3	Gauge port	PF 1/4 - 14
A3	Gear pump delivery port	PF 1/2 - 19
B3	Gear pump suction port	PF 3/4 - 20.5
Dr3	Gear pump drain port	PF 3/8 - 15

1) MAIN PUMP (1/2)

The main pump consists of two piston pumps (front & rear) and valve block.

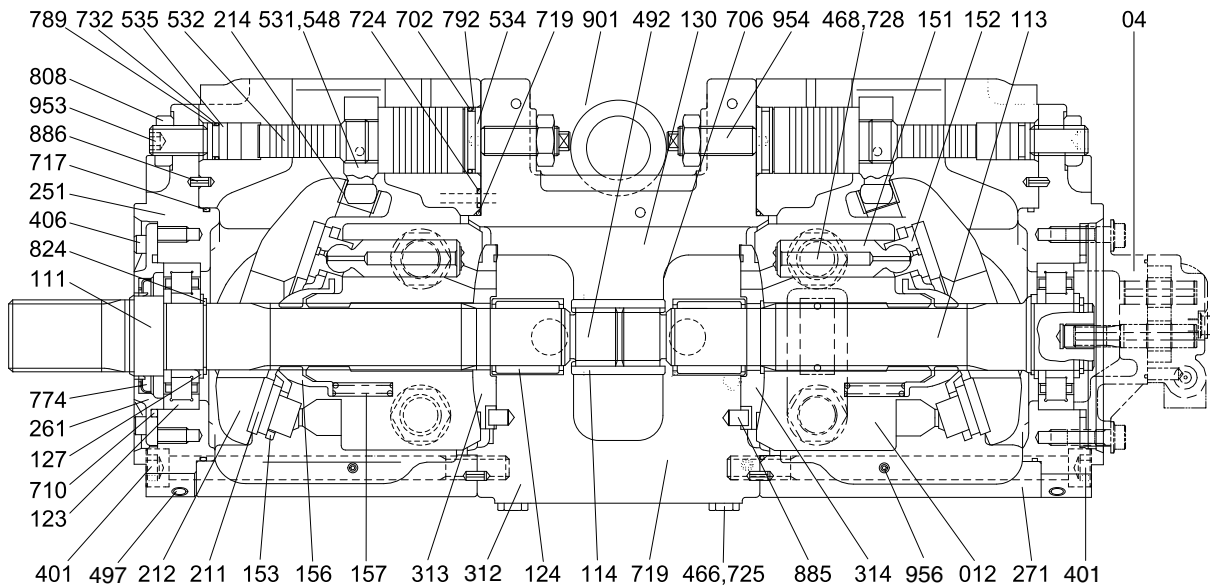

380A2MP02

04	Gear pump	261	Seal cover (F)	717	O-ring
111	Drive shaft (F)	271	Pump casing	719	O-ring
113	Drive shaft (R)	312	Valve block	724	Square ring
114	Spline coupling	313	Valve plate (R)	725	O-ring
123	Roller bearing	314	Valve plate (L)	728	O-ring
124	Needle bearing	401	Hexagon socket screw	732	O-ring
127	Bearing spacer	406	Hexagon socket screw	774	Oil seal
012	Cylinder block	466	VP Plug	789	Back up ring
151	Piston	468	VP Plug	792	Back up ring
152	Shoe	497	Plug	808	Hexagon head nut
153	Set plate	531	Tilting pin	824	Snap ring
156	Bushing	532	Servo piston	885	Pin
157	Cylinder spring	534	Stopper (L)	886	Spring pin
211	Shoe plate	535	Stopper (S)	901	Eye bolt
212	Swash plate	548	Feedback pin	953	Set screw
214	Bushing	702	O-ring	954	Adjust screw
251	Support plate	710	O-ring	956	Set screw

MAIN PUMP (2/2)

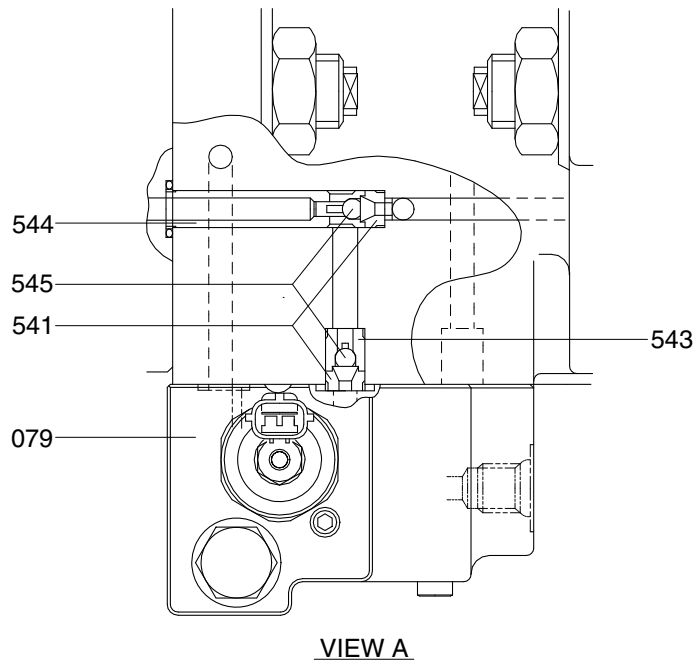

380A2MP03

- | | | | | | |
|-----|-----------------------------|-----|----------|-----|------------|
| 079 | Proportional reducing valve | 543 | Stoper 1 | 545 | Steel ball |
| 541 | Seat | 544 | Stoper 1 | | |

2) REGULATOR (1/2)

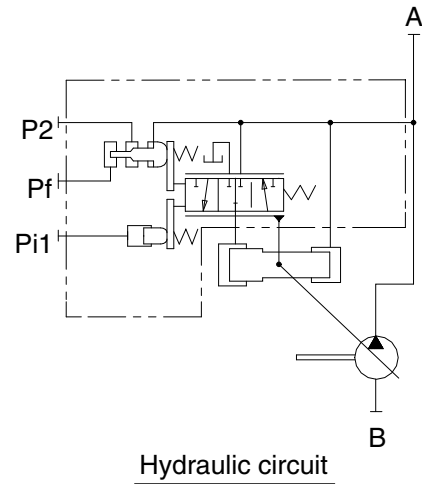
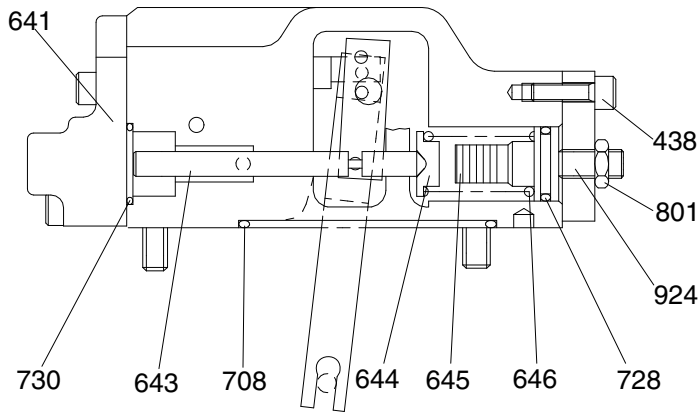
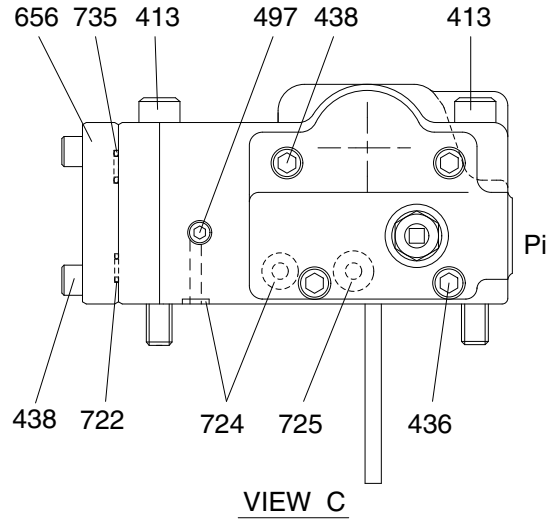
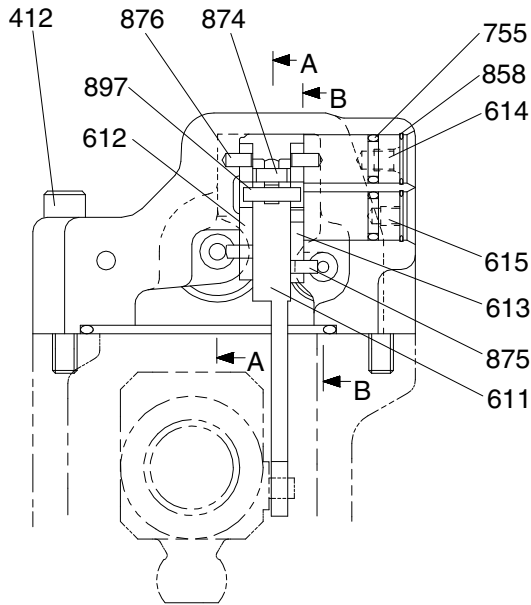

380A2MP04

412 Hexagon socket screw	708 O-ring
413 Hexagon socket screw	722 O-ring
436 Hexagon socket screw	724 O-ring
438 Hexagon socket screw	725 O-ring
497 Plug	728 O-ring
611 Feed back lever	730 O-ring
612 Lever (1)	735 O-ring
613 Lever (2)	755 O-ring
614 Fulcrum plug	801 Nut
615 Adjust plug	858 Snap ring
643 Pilot piston	874 Pin
644 Spring seat (Q)	875 Pin
645 Adjust stem (Q)	876 Pin
646 Pilot spring	897 Pin
656 Block cover	924 Set screw

Port	Port name	Port size
Pi	Pilot port	PF 1/4-15
Pf	Power shift port	-
P2	Companion delivery port	-

REGULATOR (2/2)

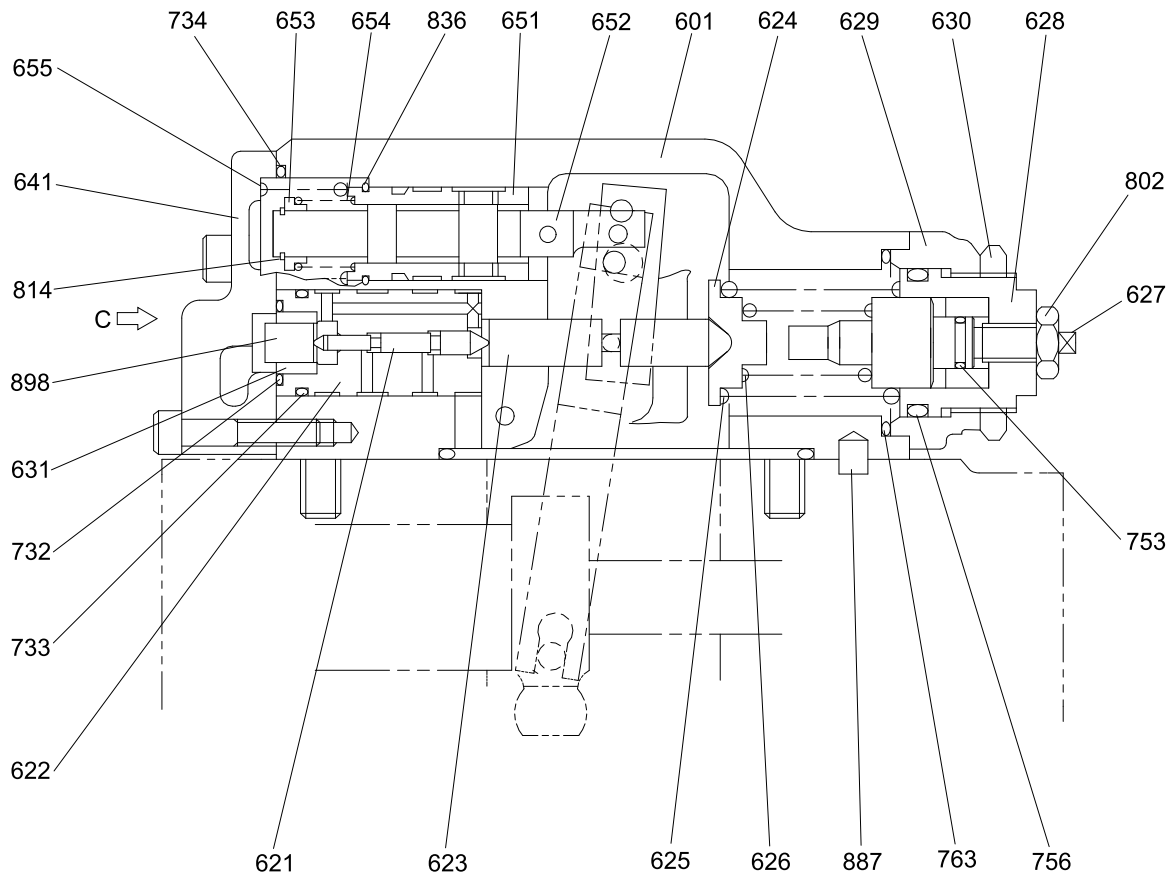

SECTION A-A

380A2MP05

601	Casing	630	Lock nut	734	O-ring
621	Compensator piston	631	Sleeve, pf	753	O-ring
622	Piston case	641	Pilot cover	756	O-ring
623	Compensator rod	651	Sleeve	763	O-ring
624	Spring seat (C)	652	Spool	802	Nut
625	Outer spring	653	Spring seat	814	Snap ring
626	Inner spring	654	Return spring	836	Stop ring
627	Adjust stem (C)	655	Set spring	887	Pin
628	Adjust screw (C)	732	O-ring	898	Pin
629	Cover (C)	733	O-ring		

3) GEAR PUMP

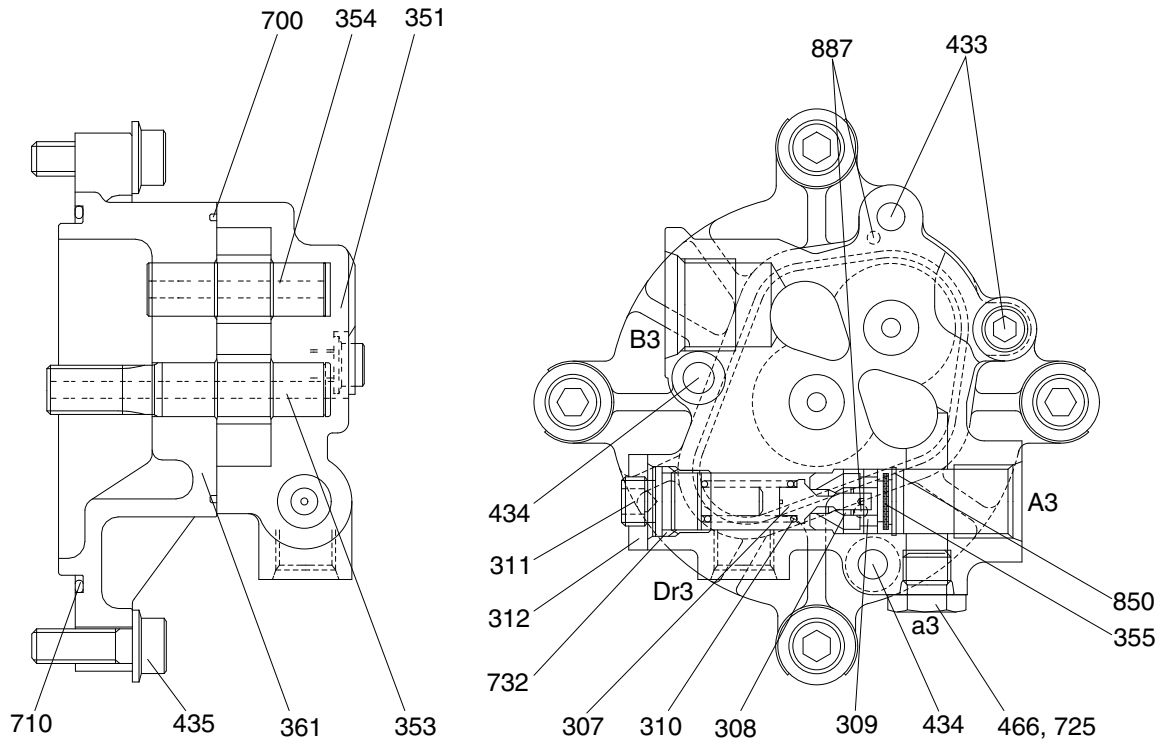

380A2MP06

307 Poppet	353 Drive gear	466 Plug
308 Seat	354 Driven gear	700 Ring
309 Ring	355 Filter	710 O-ring
310 Spring	361 Front case	725 O-ring
311 Adjusting screw	433 Flange socket	732 O-ring
312 Nut	434 Flange socket	850 Snap ring
351 Gear case	435 Flange socket	887 Pin

4) EPPR VALVE AND CASING SUB

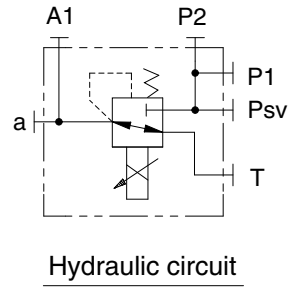
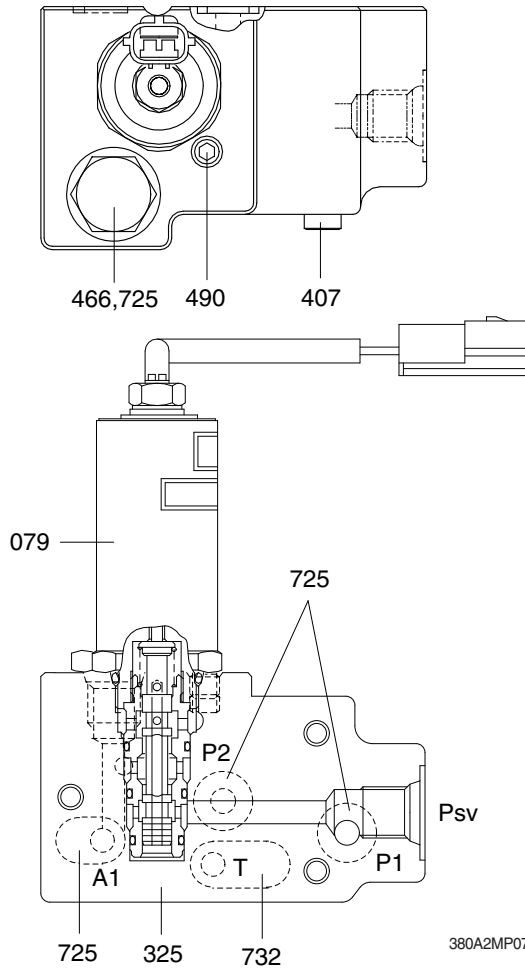

- 079 EPPR valve assy
- 325 Valve casing
- 407 Hexagon socket head screw
- 466 VP plug
- 490 Plug
- 725 O-ring
- 732 O-ring

Port	Port name	Port size
Psv	Servo assist port	PF 1/4-15
P1, P2	Internal assist port	-
A1	Power shift port	-
a	Gauge port	PF 1/4-15

5) EPPR VALVE ASSY

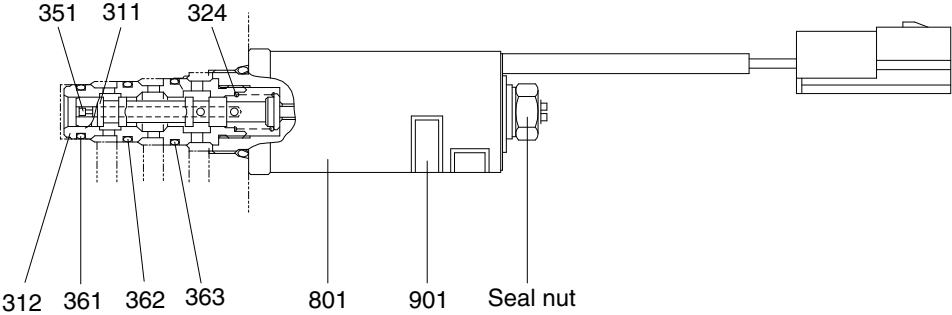

380A2MP08

311 Spool
 312 Sleeve
 324 Spring

351 Orifice
 361 O-ring
 362 O-ring

363 O-ring
 801 Solenoid
 901 Name plate

2. FUNCTION

1) MAIN PUMP

The pumps may be classified roughly into the rotary group performing a rotary motion and working as the major part of the whole pump function: the swash plate group that varies the delivery rates: and the valve cover group that changes over oil suction and discharge.

(1) Rotary group

The rotary group consists of drive shaft (F)(111), cylinder block (012), piston shoes set (151,152), set plate (153), spherical bush (156) and cylinder spring (157). The drive shaft is supported by bearing (123,124) at its both ends.

The shoe is caulked to the piston to form a spherical coupling. It has a pocket to relieve thrust force generated by loading pressure and the take hydraulic balance so that it slides lightly over the shoe plate (211). The sub group composed by a piston and a shoe is pressed against the shoe plate by the action of the cylinder spring via a retainer and a spherical bush. Similarly, the cylinder block is pressed against valve plate (313) by the action of the cylinder spring.

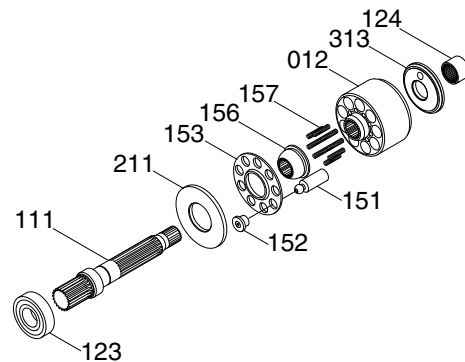

32092MP03

(2) Swash plate group

The swash plate group consists of swash plate (212), shoe plate (211), swash plate support (251), tilting bush (214), tilting pin (531) and servo piston (532).

The swash plate is a cylindrical part formed on the opposite side of the sliding surface of the shoe and is supported by the swash support.

If the servo piston moves to the right and left as hydraulic force controlled by the regulator is admitted to hydraulic chamber located on both sides of the servo piston, the swash plate slides over the swash plate support via the spherical part of the tilting pin to change the tilting angle (α)

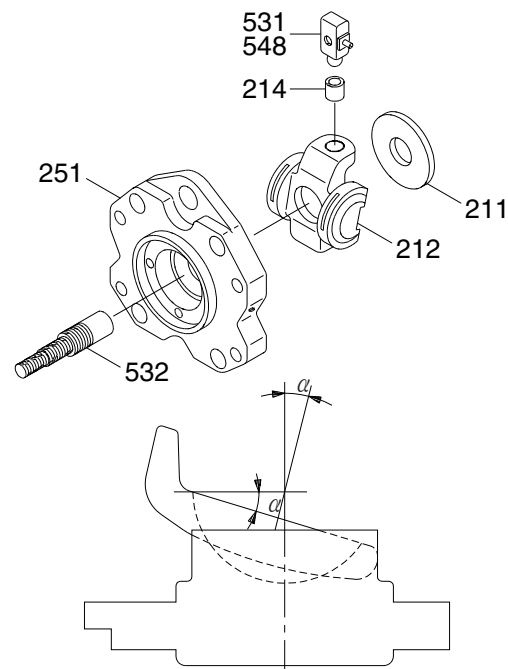

3607A2MP10

(3) Valve block group

The valve block group consists of valve block (312), valve plate (313) and valve plate pin (885).

The valve plate having two melon-shaped ports is fixed to the valve block and feeds and collects oil to and from the cylinder block.

The oil changed over by the valve plate is connected to an external pipeline by way of the valve block.

Now, if the drive shaft is driven by a prime mover (electric motor, engine, etc), it rotates the cylinder block via a spline linkage at the same time. If the swash plate is tilted as in Fig (previous page) the pistons arranged in the cylinder block make a reciprocating motion with respect to the cylinder block, while they revolve with the cylinder block.

If you pay attention to a single piston, it performs a motion away from the valve plate (oil sucking process) within 180 degrees, and makes a motion towards the valve plate (or oil discharging process) in the rest of 180 degrees. When the swash plate has a tilting angle of zero, the piston makes no stroke and discharges no oil.

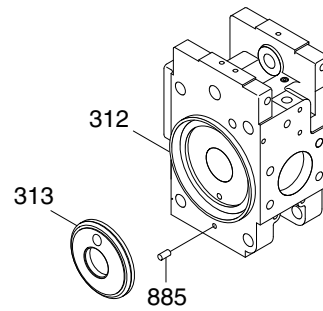

380A2MP09

2) REGULATOR

Regulator consists of the negative flow control, total horse power control and power shift control function.

(1) Negative flow control

By changing the pilot pressure P_i , the pump tilting angle (delivery flow) is regulated arbitrarily, as shown in the figure.

This regulator is of the negative flow control in which the delivery flow Q decreases as the pilot pressure P_i rises.

With this mechanism, when the pilot pressure corresponding to the flow required for the work is commanded, the pump discharges the required flow only, and so it does not consume the power uselessly.

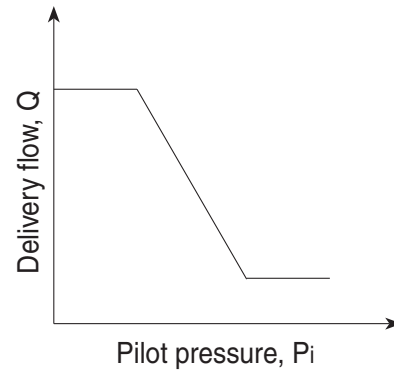

① Flow reducing function

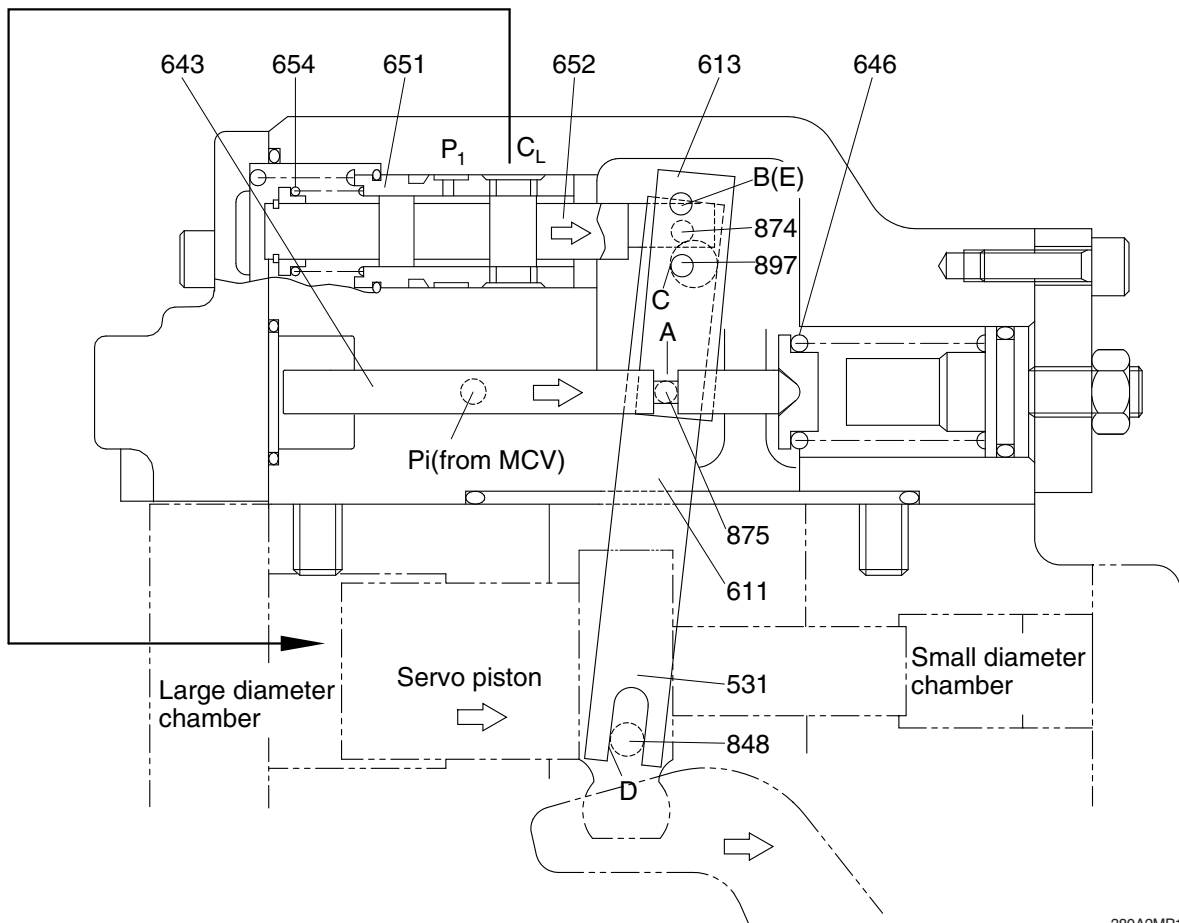

380A2MP10

As the pilot pressure P_i rises, the pilot piston (643) moves to the right to a position where the force of the pilot spring (646) balances with the hydraulic force.

The groove (A) in the pilot piston is fitted with the pin (875) that is fixed to lever 2 (613). Therefore, when the pilot piston moves, lever 2 rotates around the fulcrum of point B [Fixed by the fulcrum plug (614) and pin (875)]. Since the large hole section (C) of lever 2 contains a protruding pin (897) fixed to the feedback lever (611), the pin (897) moves to the right as lever 2 rotates. Since the opposing-flat section (D) of the feedback lever is fitted with the pin (548) fixed by the tilting pin (531) that swings the swash plate, the feedback lever rotates around the fulcrum of point D, as the pin (897) moves.

Since the feedback lever is connected with the spool (652) via the pin (874), the spool moves to the right.

The movement of the spool causes the delivery pressure P_1 to connect to port CL through the spool and to be admitted to the large diameter section of the servo piston. The delivery pressure P_1 that is constantly admitted to the small diameter section of the servo piston moves the servo piston to the right due to the area difference, resulting in decrease of the tilting angle.

When the servo piston moves to the right, point D also moves to the right. The spool is fitted with the return spring (654) and is tensioned to the left at all times, and so the pin (897) is pressed against the large hole section (C) of lever 2.

Therefore, as point D moves, the feedback lever rotates around the fulcrum of point C, and the spool is shifted to the left. This causes the opening between the sleeve (651) and spool (652) to close slowly, and the servo piston comes to a complete stop when it closes completely.

② Flow increasing function

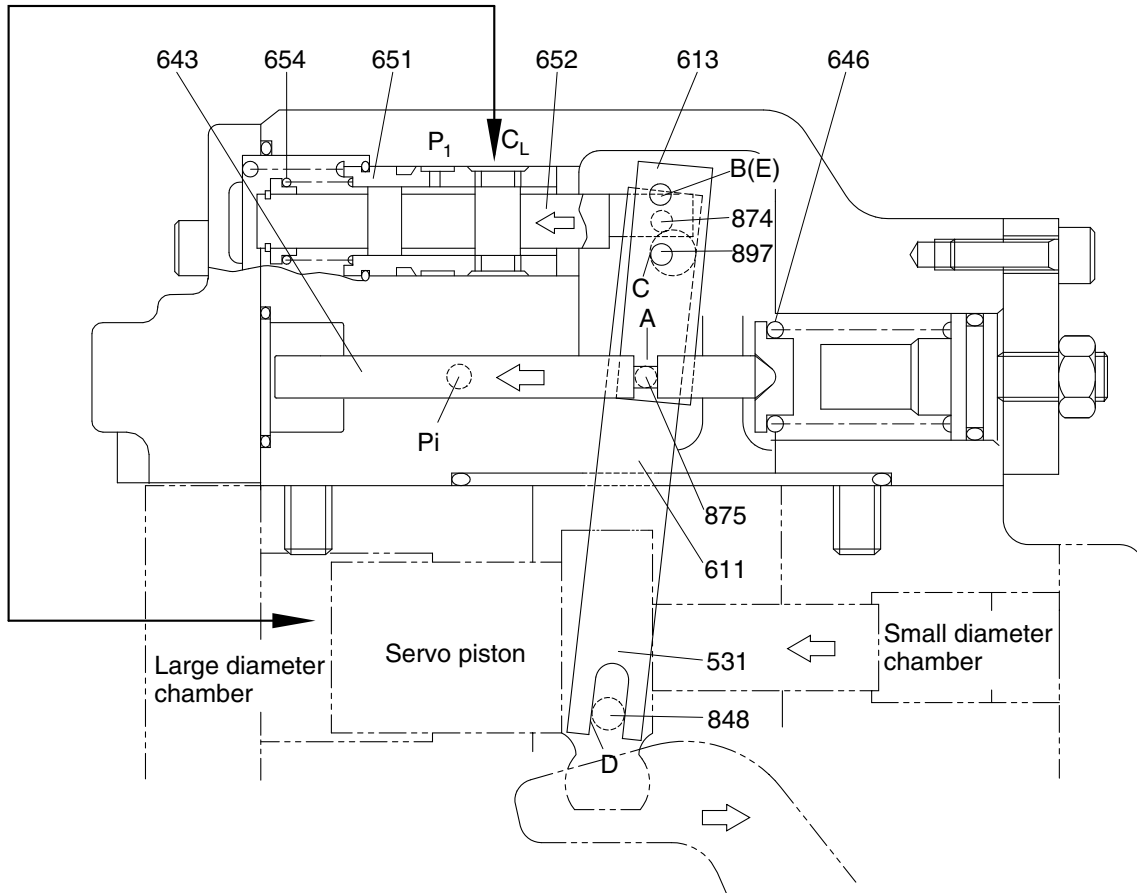

380A2MP11

As the pilot pressure P_i decreases, the pilot piston (643) moves to the left by the action of the pilot spring (646) and causes lever 2 (613) to rotate around the fulcrum of point B. Since the pin (897) is pressed against the large hole section (C) of lever 2 by the action of the return spring (654) via the spool (652), pin (874), and feedback lever (611), the feedback lever rotates around the fulcrum of point D as lever 2 rotates, and shifts the spool to the left. Port CL opens a way to the tank port as the spool moves. This deprives the large diameter section of the servo piston of pressure, and shifts the servo piston to the left by the discharge pressure P_1 in the small diameter section, resulting in an increase in the flow rate.

As the servo piston moves, point D also moves to the left, the feedback lever rotates around the fulcrum of point C, and the spool moves to the right till the opening between the spool and sleeve is closed.

③ Adjustment of flow control characteristic

The flow control characteristic can be adjusted with the adjusting screw.

Adjust it by loosening the hexagon nut (801) and by tightening (or loosening) the hexagonal socket head screw (924).

Tightening the screw shifts the control chart to the right as shown in the figure.

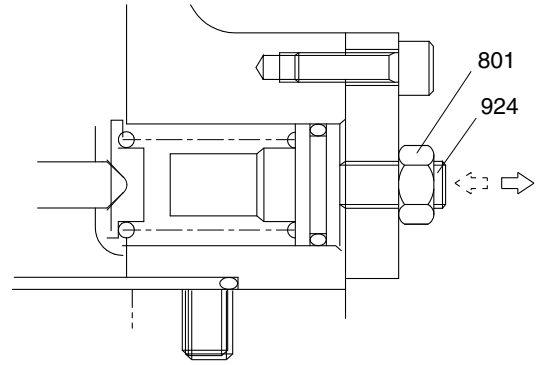

※ Adjusting values are shown in table.

Speed (min ⁻¹)	Adjustment of flow control characteristic		
	Tightening amount of adjusting screw (924) (Turn)	Flow control starting pressure change amount (kgf/cm ²)	Flow change amount (l/min)
1800	+1/4	+1.0	+18.9

380A2MP12

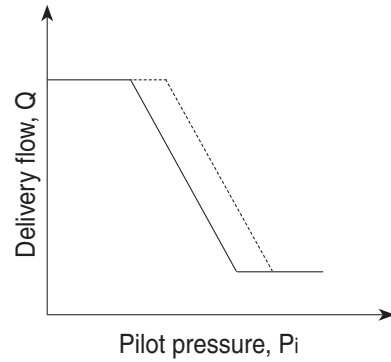

(2) Total horsepower control

The regulator decreases the pump tilting angle (delivery flow) automatically to limit the input torque within a certain value with a rise in the delivery pressure P1 of the self pump and the delivery pressure P2 of the companion pump.

(The input horsepower is constant when the speed is constant.)

Since the regulator is of the simultaneous total horsepower type that operates by the sum of load pressures of the two pumps in the tandem double-pump system, the prime mover is automatically prevented from being overloaded, irrespective of the load condition of the two pumps, when horsepower control is under way.

Since this regulator is of the simultaneous total horsepower type, it controls the tilting angles (displacement volumes) of the two pumps to the same value as represented by the following equation :

$$\begin{aligned} T_{in} &= P1 \times q / 2 \pi + P2 \times q / 2 \pi \\ &= (P1+P2) \times q / 2 \pi \end{aligned}$$

The horsepower control function is the same as the flow control function and is summarized in the following. (for detailed behaviors of respective parts, refer to the section of flow control).

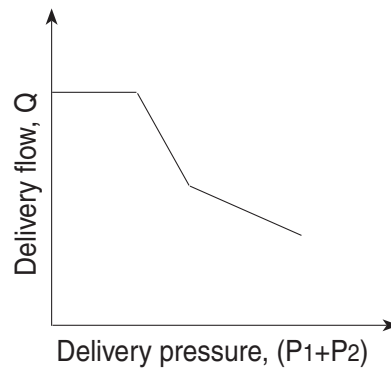

① Overload preventive function

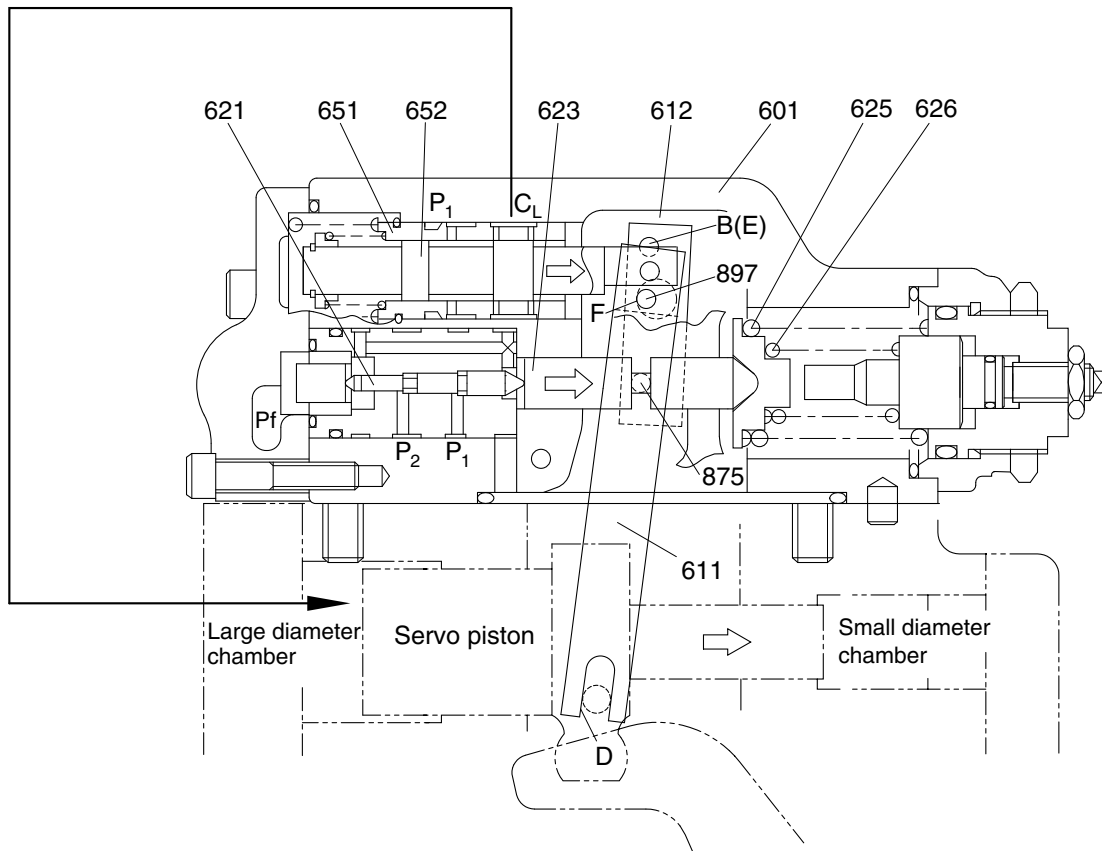

380A2MP13

When the self pump delivery pressure P1 or the companion pump delivery pressure P2 rises, it acts on the stepped part of the compensating piston (621). It presses the compensating rod (623) to the right till the force of the outer spring (625) and inner spring (626) balances with the hydraulic force. The movement of the compensating rod is transmitted to lever 1 via pin (875).

Lever 1 rotates around the pin (875) (E) fixed to the casing (601).

Since the large hole section (F) of lever 1 contains a protruding pin (897) fixed to the feedback lever (611), the feedback lever rotates around the fulcrum of point D as lever 1 rotates, and then the spool (652) is shifted to the right. As the spool moves, the delivery pressure P1 is admitted to the large diameter section of the servo piston via port CL, causes the servo piston move to the right, reduces the pump delivery flow rate, and prevents the prime mover from being overloaded.

The movement of the servo piston is transmitted to the feedback lever via point D. Then the feedback lever rotates around the fulcrum of point F and the spool is shifted to the left. The spool moves till the opening between the spool (652) and sleeve (651) is closed.

② Flow reset function

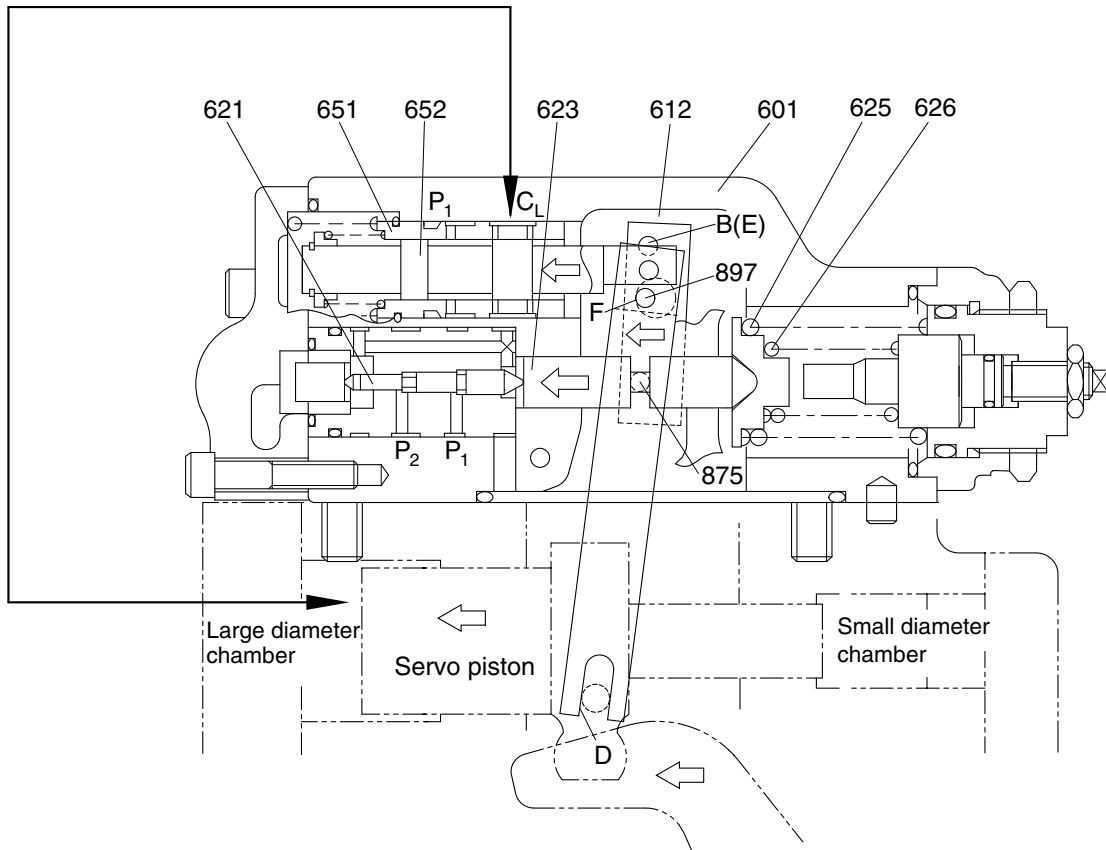

380A2MP14

As the self pump delivery pressure P_1 or the companion pump delivery pressure P_2 decreases, the compensating rod (623) is pushed back by the action of the springs (625 & 626) to rotate lever 1 (612) around point E. Rotating of lever 1 (612) causes the feedback lever (611) to rotate around the fulcrum of point D and then the spool (652) to move to the left. As a result, port CL opens a way to the tank port.

This causes the servo piston to move to the left and the pump's delivery rate to increase.

The movement of the servo piston is transmitted to the spool by the action of the feedback mechanism to move it till the opening between the spool and sleeve is closed.

③ Low tilting angle (low flow) command preferential function

As mentioned above, flow control and horsepower control tilting angle commands are transmitted to the feedback lever and spool via the large-hole sections (C & F) of levers 1 and 2. However, since sections C and F have the pins (Ø4) protruding from the large hole (Ø8), only the lever lessening the tilting angle contacts the pin (897); the hole (Ø8) in the lever of a larger tilting angle command is freed without contacting the pin (897). Such a mechanical selection method permits preference of the lower tilting angle command of the flow control and horsepower control.

④ Adjustment of input horsepower

Since the regulator is of total cumulative horsepower type, adjust the adjusting screws of both the front and rear pumps, when changing the horsepower set values. The pressure change values by adjustment are based on two pumps pressurized at the same time, and the values will be doubled when only one pump is loaded.

a. Adjustment of outer spring

Adjust it by loosening the hexagon nut (630) and by tightening (or loosening) the adjusting screw C (628). Tightening the screw shifts the control chart to the right and increases the input horsepower as shown in the figure. Since turning the adjusting screw C by N turns changes the setting of the inner spring (626), return the adjusting screw QI (627) by $N \times A$ turns at first. ($A=1.85$)

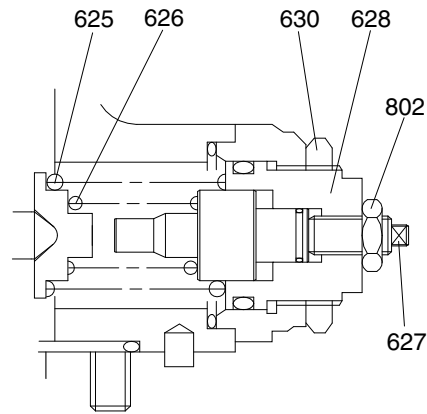

※ Adjusting values are shown in table.

Speed	Adjustment of outer spring		
	Tightening amount of adjusting screw (C) (628)	Compensating control starting pressure change amount	Input torque change amount
(min ⁻¹)	(Turn)	(kgf/cm ²)	(kgf · m)
1800	+1/4	+17.8	+6.7

380A2MP15

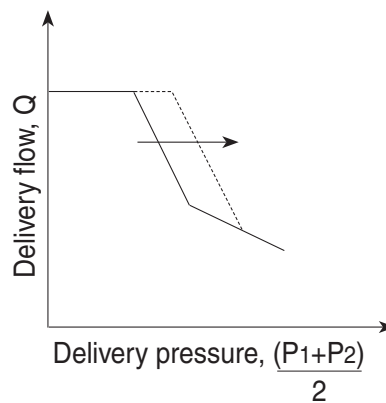

b. Adjustment of inner spring

Adjust it by loosening the hexagon nut (802) and by tightening (or loosening) the adjusting screw QI (627).

Tightening the screw increases the flow and then the input horsepower as shown in the figure.

※ Adjusting valves are shown in table.

Speed	Adjustment of inner spring		
	Tightening amount of adjusting screw (QI) (627)	Flow change amount	Input torque change amount
(min ⁻¹)	(Turn)	(lpm)	(kgf · m)
1800	+1/4	+16.7	+7.2

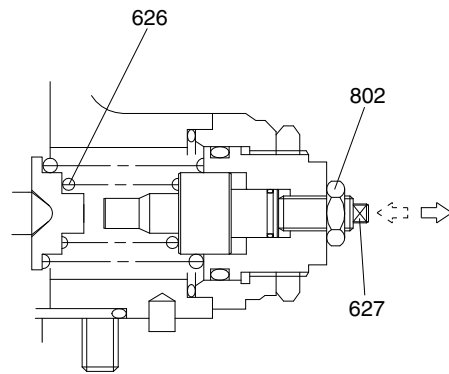

380A2MP16

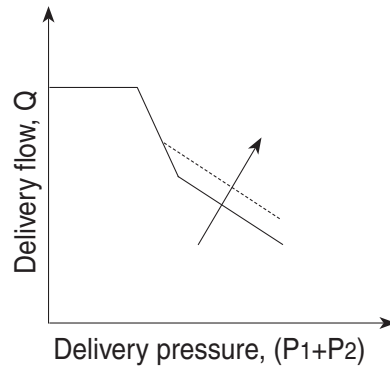

(3) Power shift control

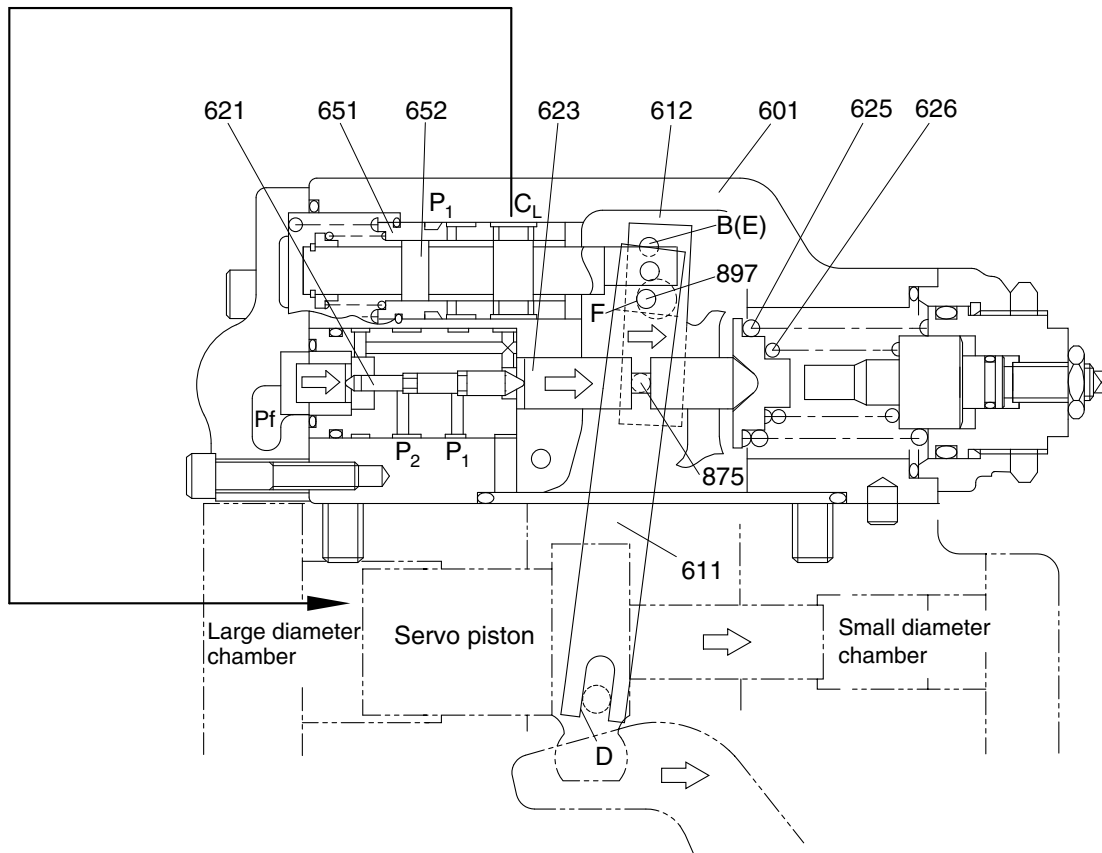

380A2MP17

The set horsepower valve is shifted by varying the command current level of the proportional pressure reducing valve attached to the pump. Only one proportional pressure reducing valve is provided.

However, the secondary pressure P_f (power shift pressure) is admitted to the horsepower control section of each pump regulator through the pump's internal path to shift it to the same set horsepower level.

This function permits arbitrary setting of the pump output power, thereby providing the optimum power level according to the operating condition.

The power shift pressure P_f controls the set horsepower of the pump to a desired level, as shown in the figure.

As the power shift pressure P_f rises, the compensating rod (623) moves to the right via the pin (898) and compensating piston (621).

This decreases the pump tilting angle and then the set horsepower in the same way as explained in the overload preventive function of the horsepower control. On the contrary, the set horsepower rises as the power shift pressure P_f falls.

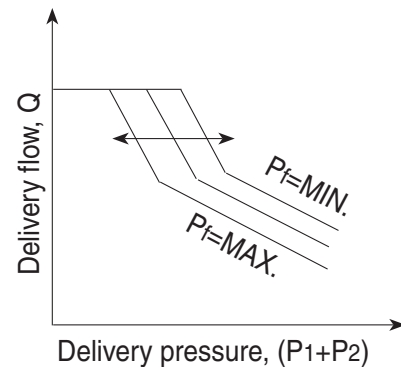

(4) Adjustment of maximum and minimum flows

① Adjustment of maximum flow

Adjust it by loosening the hexagon nut (808) and by tightening (or loosening) the set screw (954).

The maximum flow only is adjusted without changing other control characteristics.

Speed	Adjustment of max flow spring	
	Tightening amount of adjusting screw (954)	Flow change amount
(min ⁻¹)	(Turn)	(ℓ/min)
1800	+1/4	-6.9

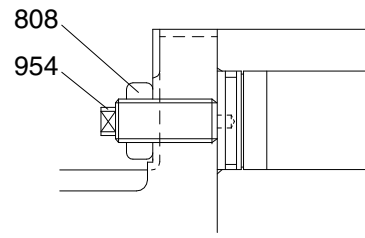

R290RE08(5)

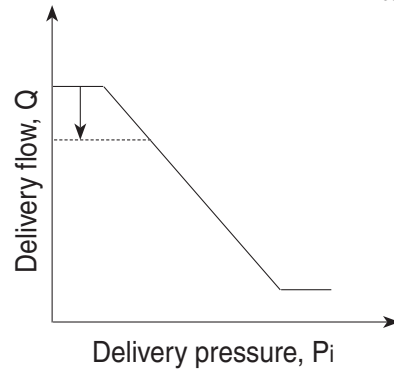

② Adjustment of minimum flow

Adjust it by loosening the hexagon nut (808) and by tightening (or loosening) the hexagonal socket head set screw (953). Similarly to the adjustment of the maximum flow, other characteristics are not changed.

However, remember that, if tightened too much, the required horsepower during the maximum delivery pressure (or during relieving) may increase.

Speed	Adjustment of min flow spring	
	Tightening amount of adjusting screw (953)	Flow change amount
(min ⁻¹)	(Turn)	(ℓ/min)
1800	+1/4	+6.9

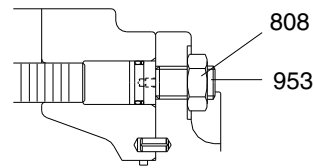

380A2MP18

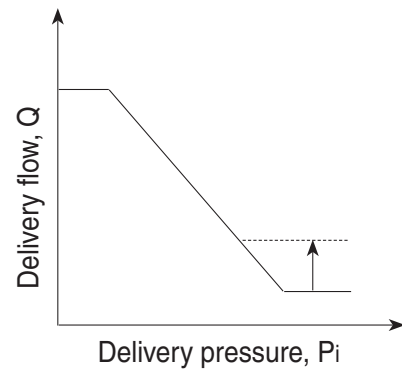

GROUP 2 MAIN CONTROL VALVE

1. STRUCTURE (1/2)

VIEW A

VIEW B

VIEW C

VIEW D

Mark	Port name	Port size	Tightening torque
(P3)	-	PF1	20.4~25.5 kgf · m (148~184 lbf · ft)
(P4)	-		
(R4)	-		
Rs1	Make up port		
Rs2	Make up port	PF3/4	7.8~8.0 kgf · m (50.1~57.9 lbf · ft)
XAtr	Travel left (forward) pilot port		
XBtr	Travel left (reverse) pilot port		
(XAo)	Optional pilot port		
(XB0)	Optional pilot port		
XAc	Bucket out pilot port		
XBc	Bucket in pilot port		
XAb1	Boom up pilot port		
XBb1	Boom down pilot port		
XAb2	Boom up pilot port		
XBb2	Boom down pilot port		
XAa2	Arm out confluence pilot port		
XBa2	Arm in confluence pilot port		
XAtL	Travel right (forward) pilot port		
XBtL	Travel right (reverse) pilot port		
XAs	Swing right pilot port		
XBs	Swing left pilot port		
XAa1	Arm out pilot port		
XBa1	Arm in pilot port		
Dr1	Drain port		
Dr2	Drain port		
(PTa)	-		
(PTb)	-		
PACs	Bucket in stroke limit pilot port		
N1	Nega-con pressure pilot port (boom 1 side)		
N2	Nega-con pressure pilot port (arm 1 side)		
PG	Pilot port		
PH	Pilot port		
Px	Pressure port for attachment		
Py	Pressure port for travel		

380F2MC02

1) RELIEF VALVE SIDE VIEW

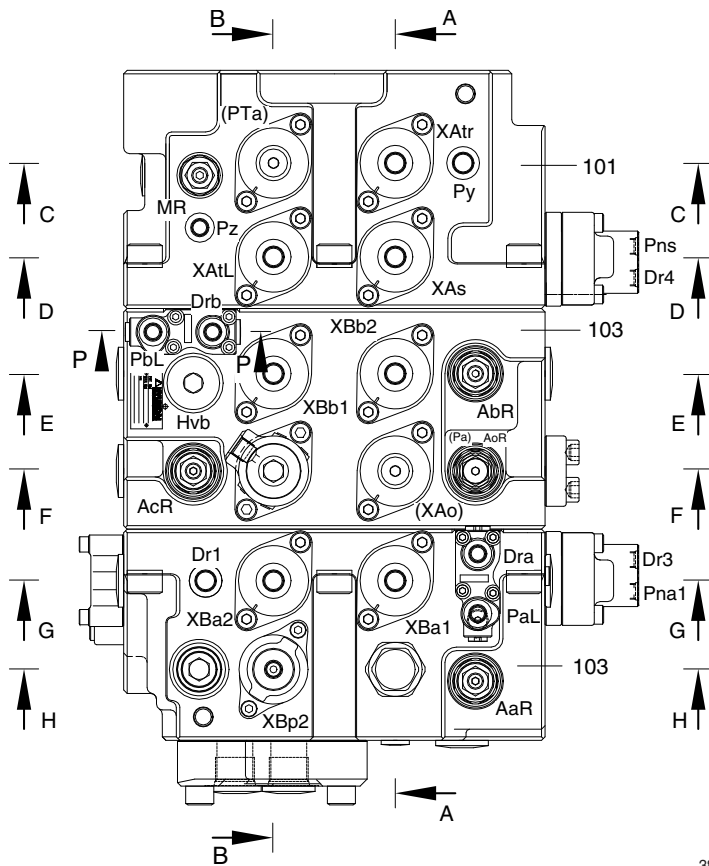

- 101 Casing A
- 102 Casing B
- 103 Casing C
- 252 Lock valve selector sub assy
- 991 Name plate
- 992 Pin

380A2MC03

2) BACK SIDE VIEW

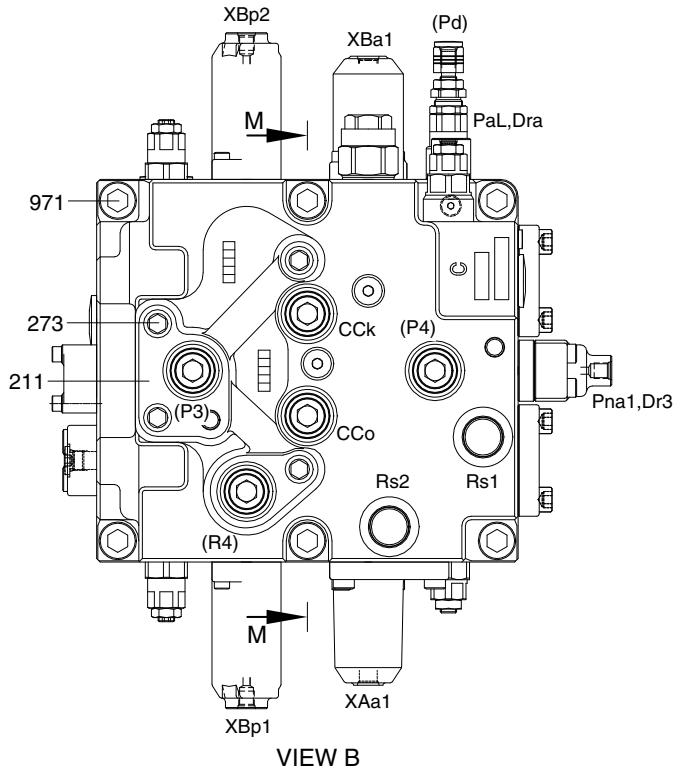

- 211 Plate
- 273 Hexagon socket screw
- 971 Hexagon socket screw

VIEW B

380A2MC04

3) P2 SPOOL SECTION

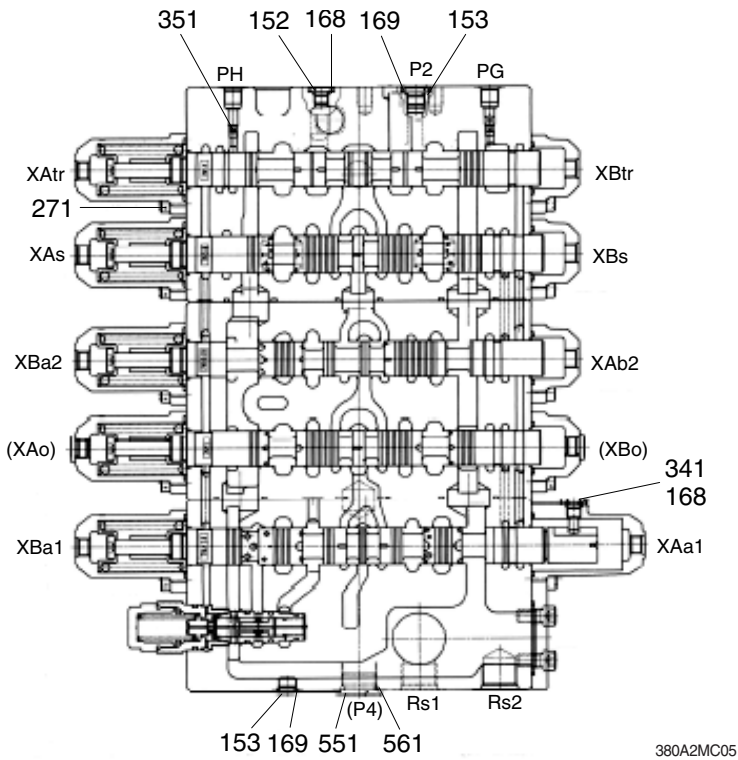

- 152 ROH plug
- 153 ROH plug
- 168 O-ring
- 169 O-ring
- 271 Hexagon socket screw
- 341 Plug
- 351 Orifice
- 551 Plug
- 561 O-ring

4) P1 SPOOL SECTION

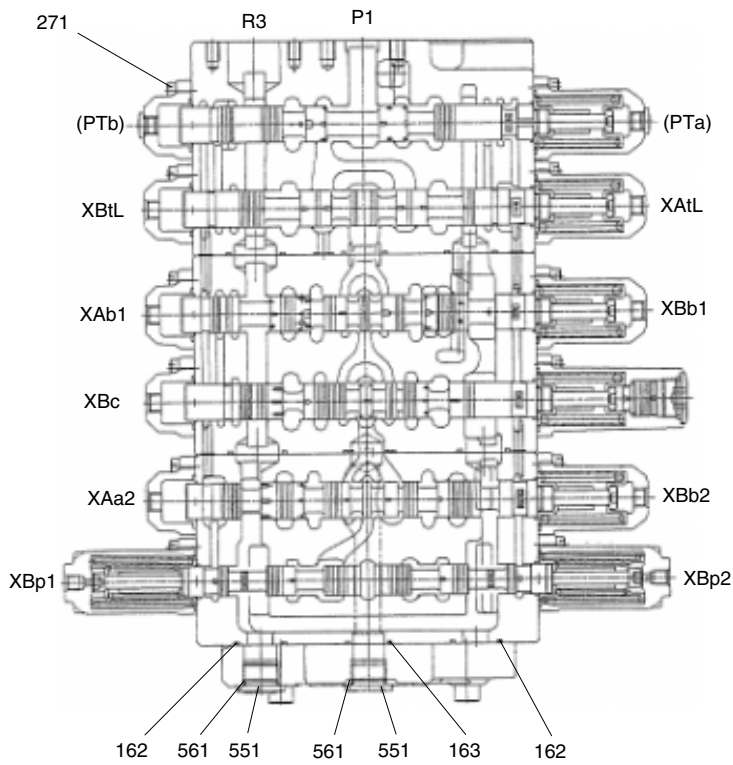

- 162 O-ring
- 163 O-ring
- 271 Hexagon socket screw
- 272 Hexagon socket screw
- 551 Plug
- 561 O-ring

5) TRAVEL RIGHT AND TRAVEL STRAIGHT SECTION

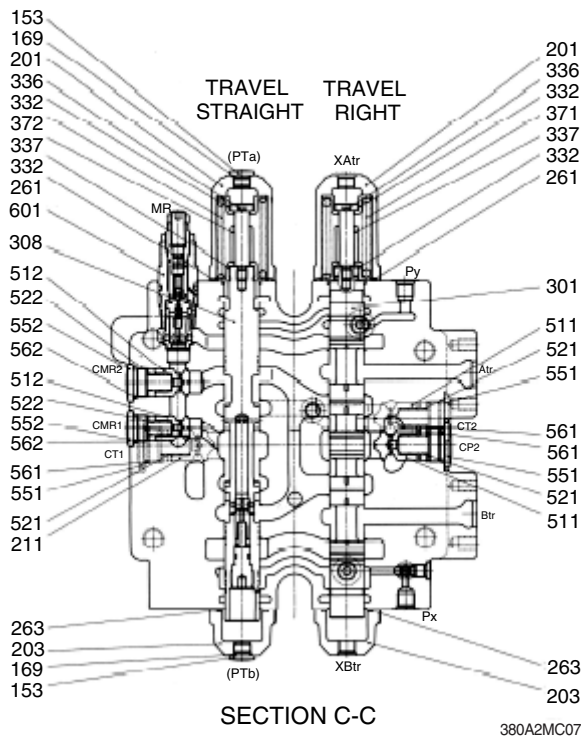

- 153 ROH plug
- 169 O-ring
- 201 Spring cover
- 203 Spool cover
- 261 O-ring
- 263 O-ring
- 301 Travel spool
- 308 Straight travel spool sub assy
- 332 Spring seat
- 336 Spacer bolt
- 337 Stopper
- 371 Spring
- 372 Spring
- 511 Poppet
- 512 Poppet
- 521 Spring
- 522 Spring
- 551 Plug
- 552 Plug
- 561 O-ring
- 562 O-ring
- 601 Main relief valve assy

6) TRAVEL LEFT AND SWING SECTION

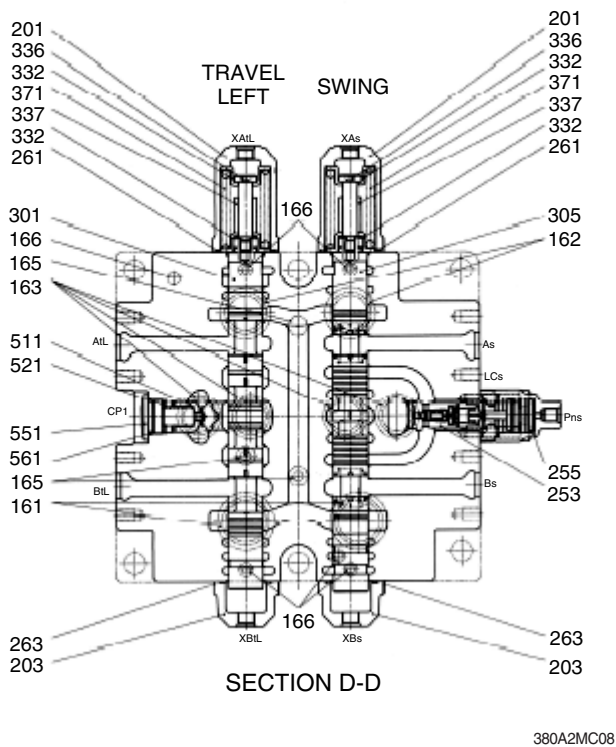

- 153 ROH plug
- 161 O-ring
- 165 O-ring
- 169 O-ring
- 170 O-ring
- 171 O-ring
- 172 O-ring
- 201 Spring cover
- 203 Spool cover
- 253 Logic poppet assy
- 255 Logic control valve assy
- 261 O-ring
- 263 O-ring
- 305 Swing spool
- 332 Spring seat
- 336 Spacer bolt
- 337 Stopper
- 371 Spring
- 511 Poppet
- 521 Spring
- 551 Plug

7) BOOM 1 AND BOOM 2 SECTION

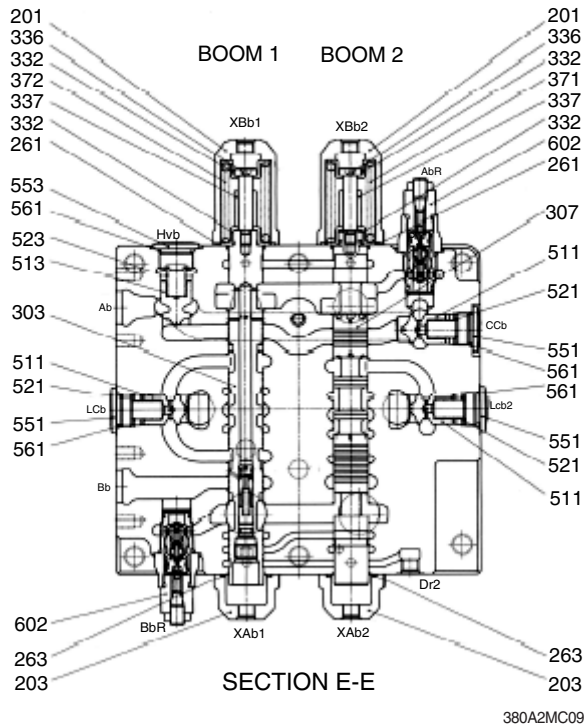

- 201 Spring cover
- 336 Spool cover
- 203 Spool cover
- 332 Spring seat
- 371 Stopper
- 337 Spring
- 332 Spacer bolt
- 602 Port relief valve assy
- 261 O-ring
- 263 O-ring
- 303 Boom 1 spool sub assy
- 307 Boom 2 spool
- 511 Poppet
- 521 Spring
- 551 Plug
- 561 O-ring
- 513 Poppet
- 521 Spring
- 523 Spring
- 551 Plug
- 553 Plug
- 561 O-ring
- 602 Port relief valve assy

8) BUCKET AND OPTION SECTION

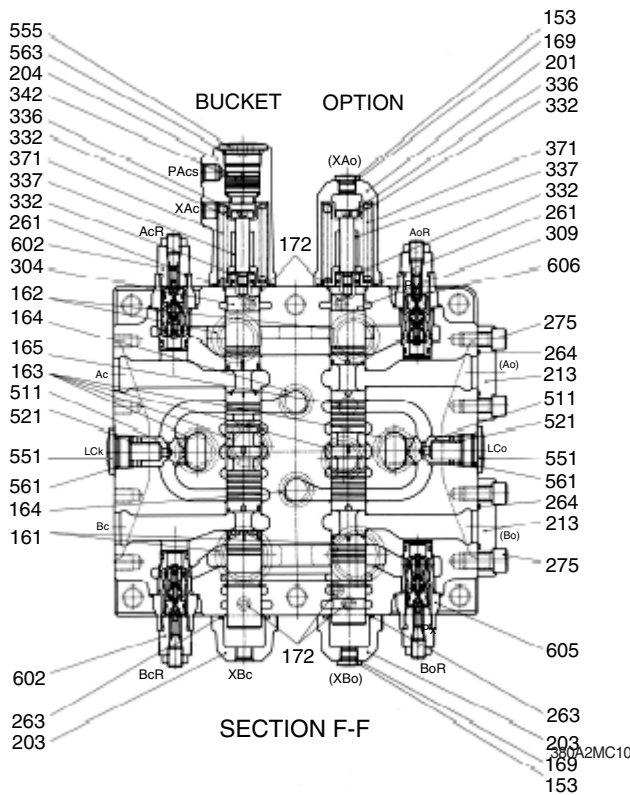

- 153 ROH plug
- 161 O-ring
- 164 O-ring
- 165 O-ring
- 170 O-ring
- 171 O-ring
- 172 O-ring
- 169 O-ring
- 201 Spring cover
- 203 Spool cover
- 204 Spring cover
- 213 Flange
- 261 O-ring
- 263 O-ring
- 264 Square ring
- 275 Hexagon socket screw
- 304 Bucket spool
- 309 Option spool
- 332 Spring seat
- 336 Spacer bolt
- 337 Stopper
- 371 Spring
- 511 Poppet
- 521 Spring
- 551 Plug
- 552 Plug
- 555 Plug
- 561 O-ring
- 562 O-ring
- 563 O-ring
- 602 Port relief valve assy
- 605 Port relief valve assy

9) ARM 1 AND ARM 2 SECTION

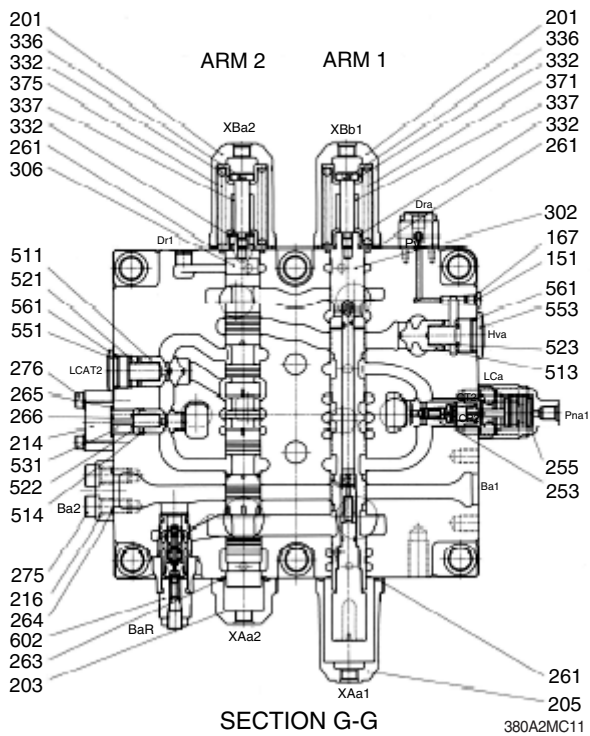

- 151 ROH plug
- 167 O-ring
- 201 Spring cover
- 203 Spool cover
- 261 O-ring
- 263 O-ring
- 205 Spool cover
- 213 Flange
- 214 Load check cover
- 253 Logic poppet assy
- 255 Logic control valve assy
- 264 Square ring
- 265 O-ring
- 266 Square ring
- 275 Hexagon socket screw
- 276 Hexagon socket screw
- 302 Arm 1 spool sub assy
- 306 Arm 2 spool
- 332 Spring seat
- 336 Spacer bolt
- 337 Stopper
- 371 Spring
- 375 Spring
- 511 Poppet
- 513 Poppet
- 514 Poppet
- 521 Spring
- 522 Spring
- 523 Spring
- 531 Spring seat
- 551 Plug
- 553 Plug
- 561 O-ring
- 562 O-ring
- 602 Port relief valve assy

10) TRAVEL LEFT AND SWING SECTION

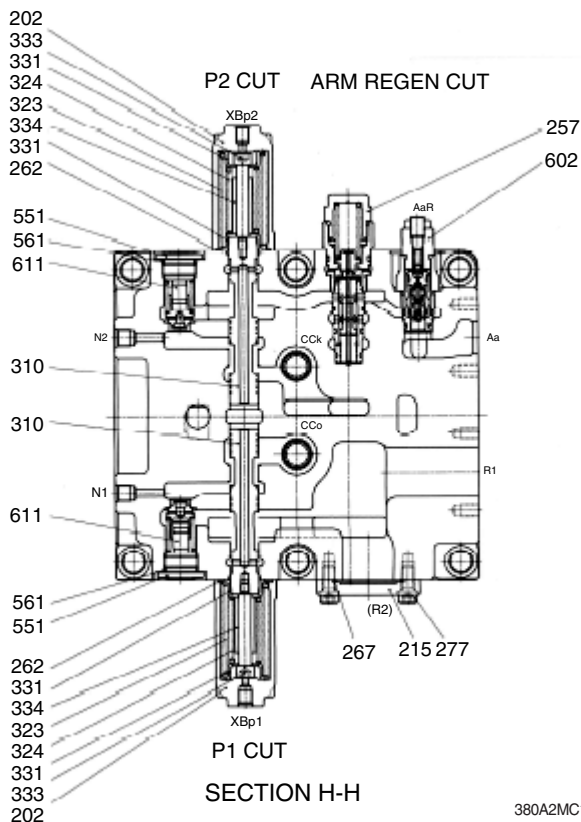

- 202 Spring cover
- 215 Blank flange
- 257 Arm regen cut sub assy
- 262 O-ring
- 267 O-ring
- 277 Hexagon socket screw
- 310 Bypass-cut assy
- 311 Bypass-cut assy
- 323 Spring
- 324 Spring
- 331 Spring seat
- 333 Spacer bolt
- 334 Stopper
- 551 Plug
- 561 O-ring
- 602 Hexagon socket screw
- 611 Nega-con relief valve assy

11) OTHER SECTION

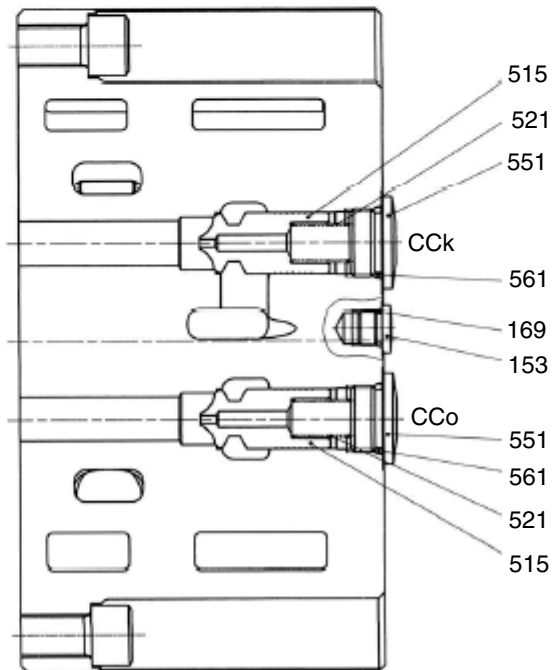
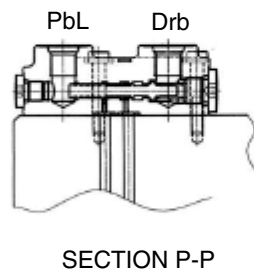
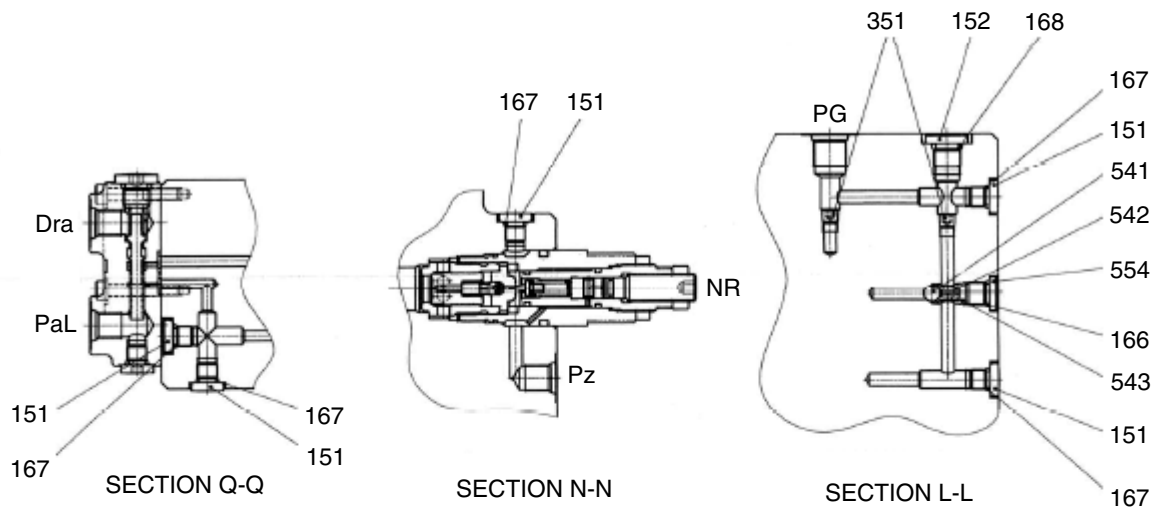

380A2MC13

151 ROH plug	169 O-ring	543 Spring
152 ROH plug	351 Orifice	551 Plug
153 ROH plug	515 Poppet	554 Plug
166 O-ring	521 Spring	561 O-ring
167 O-ring	541 Steel ball	
168 O-ring	542 Spring seat	

2. HYDRAULIC CIRCUIT

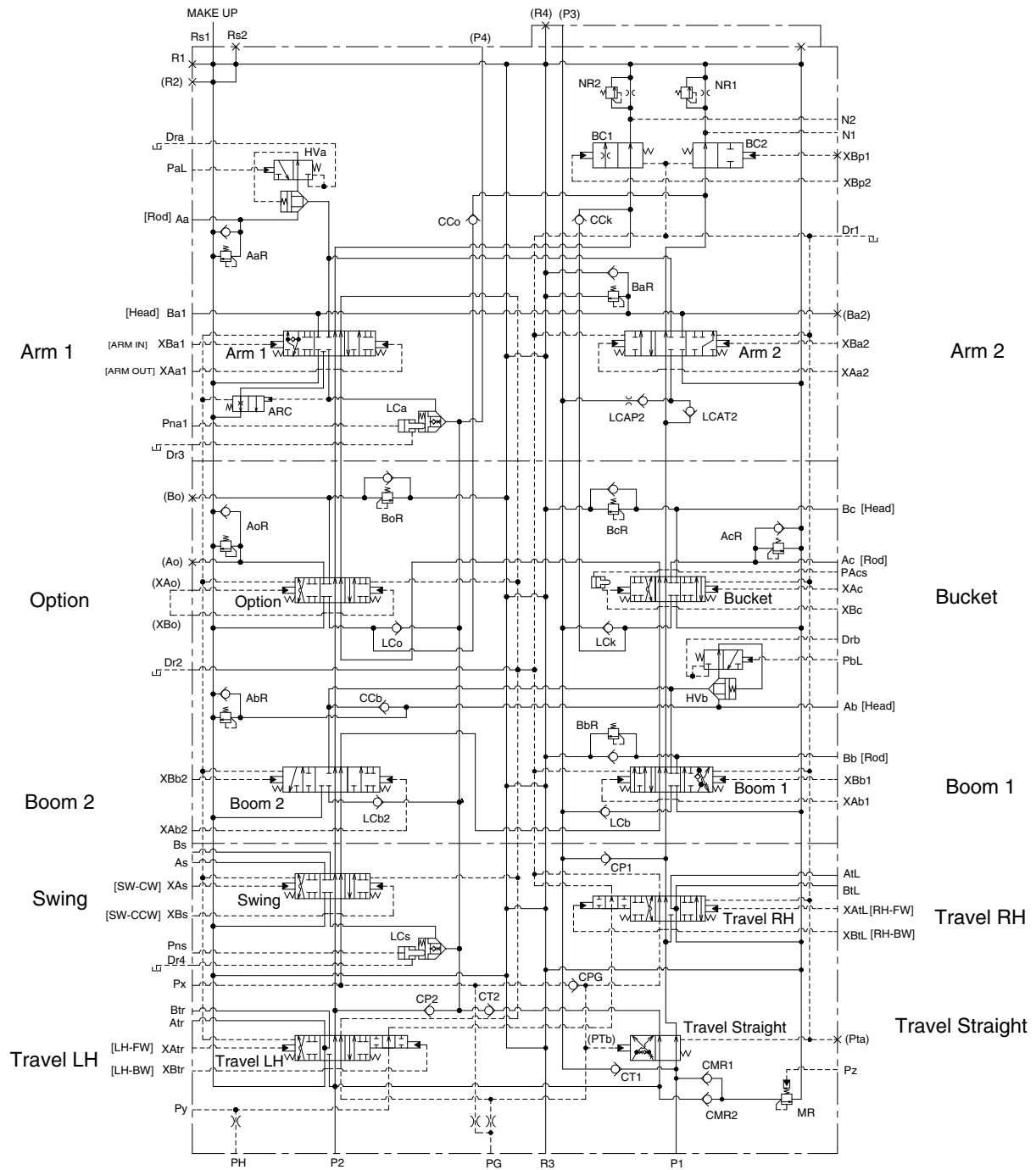

380A2MC14

3. OPERATION

1) NEUTRAL POSITIONS OF SPOOLS

(1) P1 HOUSING SIDE

When all spools are in the neutral positions, the pressurized oil discharged from the hydraulic pump (A1) passes through port P1, the main path (1), the bypass circuit (2) passing the spools for travel straight (308), travel left (301), boom 1 (303), bucket (304), arm 2 (306) and boom 1 side negative control orifice, and returns to the hydraulic oil tank through the return port (R1), (R3).

The negative control signal pressure of the boom 1 side negative control relief valve (611) is led from port N1 to the regulator on the hydraulic pump (A1) side, and controls the pump discharge flow rate to its minimum value.

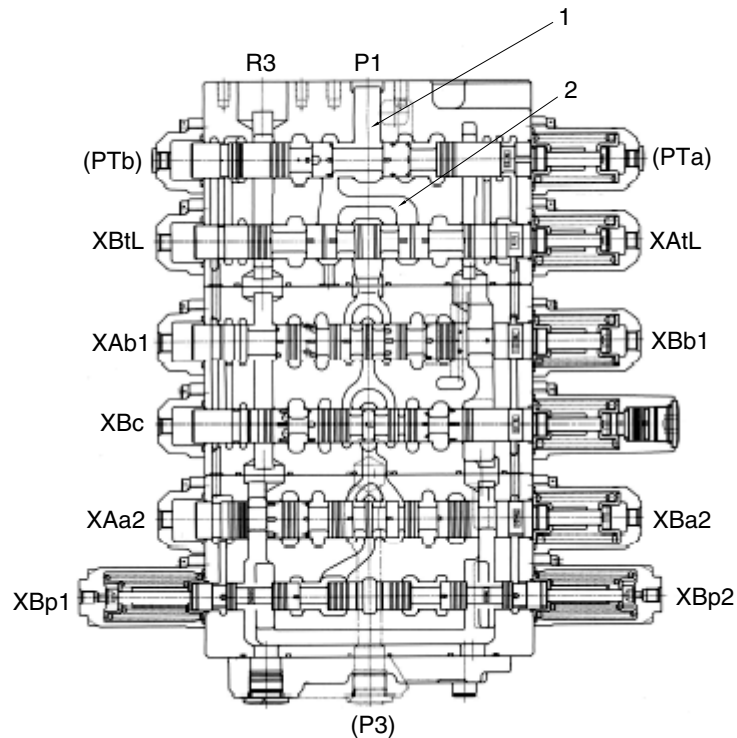

380A2MC15

(2) P2 housing side

The oil discharged from the hydraulic pump (A2) passes through port P2, the main path (3), the bypass circuit (4) passing the spools for travel right (301), swing (305), boom 2 (307), option (309), arm 1 (302) and arm 1 side negative control orifice, and returns to the hydraulic oil tank through the return port (R1), (R3).

The negative control signal pressure of the arm 1 side negative control relief valve (611) is led from port N2 to the regulator on the hydraulic pump (A2) side, and controls the pump discharge flow rate to its minimum value.

When any of nine main spools is changed over, the bypass circuit (2) or (4) is cut off and the control signal pressure at port N1 or N2 in the negative control circuit is changed tank pressure, and controls the pump discharge flow rate to its maximum value.

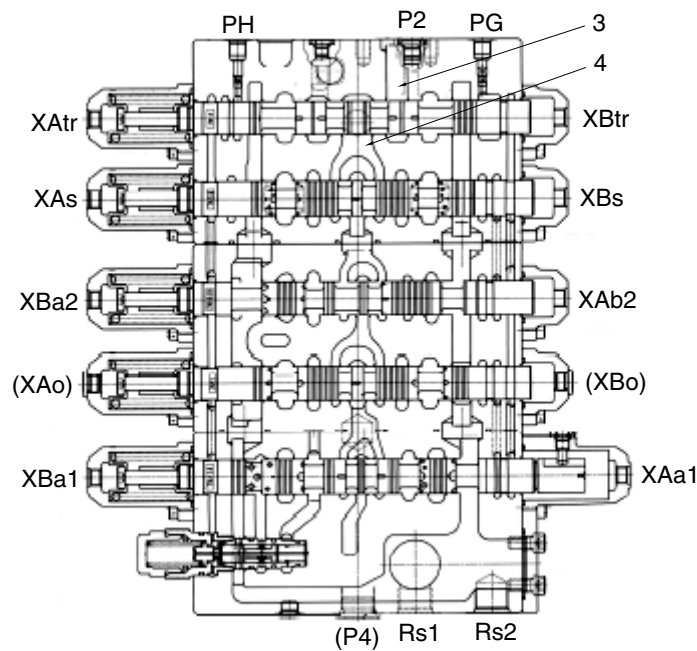

380A2MC16

2) TRAVEL OPERATION

(1) Pilot circuit

Since any of the travel spools (301) on the left or right transfers and shuts off the side-bypass path, the pressure at port Py (pressure port for travel) increases.

(2) Main circuit

When pilot port XBtL of the travel left spool (301) is pressurized, the bypass circuit (2) in the boom 1 side is shut off and pressurized oil from port P1 passes through port BtL and flows to the travel left motor.

When pilot port XBtr of the travel right spool (301) is pressurized, the bypass circuit (4) in the arm 1 side is shut off and pressurized oil from port P2 passes through port Btr and flows to the travel right motor.

On the other hand, the return oil from the travel left(right) motor passes through port AtL(AtR) and travel left (right) spool , and returns to the hydraulic oil tank through the tank port (R1), (R3).

In the case of the opposite operation (when the pilot pressure is applied to ports XAtL and XAtr of the control valve), the operation is similar.

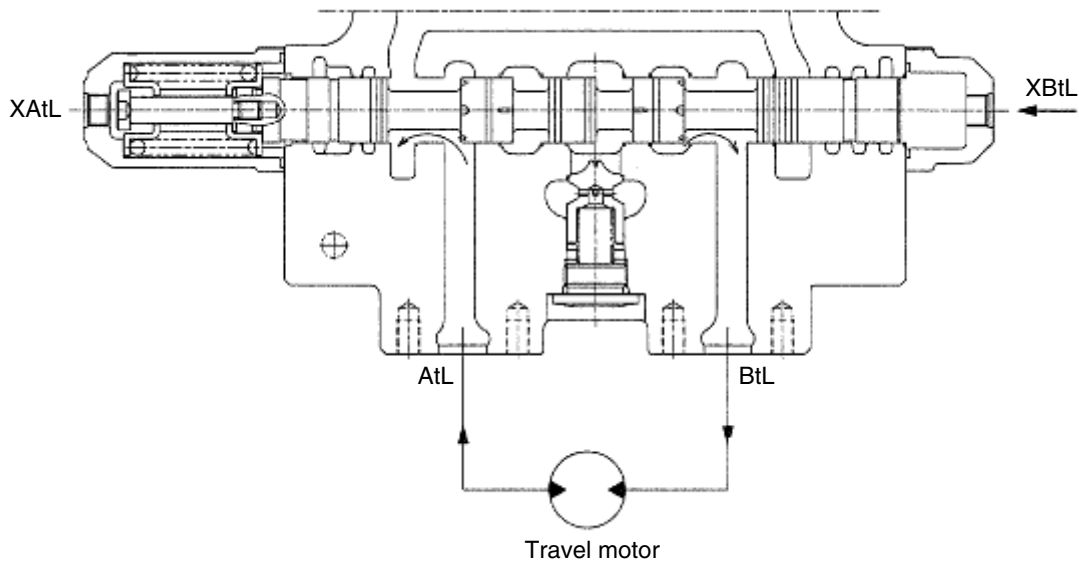

380A2MC17

3) ARM OPERATION

(1) Arm stretching operation

① Pilot circuit

Since the arm 1 spool (302) transfers and shuts off the side-bypass path, the pressure at port Px increases.

② Main circuit

During the arm stretching operation, the pilot pressure enters through ports XAa1 and XAa2. When the pressure enters through ports XAa1 and XAa2, the arm 1 and arm 2 spools transfer in the left direction in figure. The hydraulic oil entering through port P2 passes through the main path (3) and flows to the bypass circuit (4), but the bypass circuit is shut off due to transfer of the arm 1 spool (302). Therefore, the hydraulic oil from the parallel circuit pushes open the logic poppet (253) and flows through the U-shaped path to the arm 1 spool (302). Then, it flows around the periphery of the arm 1 spool (302) to port Aa, and is supplied to the arm cylinder rod side (R).

On the other hand, the oil entering through port P1 passes in the main path (1), and flows into the bypass circuit (2), and the bypass circuit is shut off due to transfer of the arm 2 spool (306). The hydraulic oil from the parallel circuit pushes open the check valve (514) and oil from the bypass circuit pushes open the check valve (511) and flows through the U-shaped path to the arm 2 spool (306). Then, it flows around the periphery of arm 2 spool (306) and joins into port Aa through the inside path.

Besides, the return oil from the arm cylinder head side (H) passes through port Ba1, flows into tank line in arm 1 side and in arm 2 side and returns to the hydraulic oil tank through the tank ports (R1), (R3).

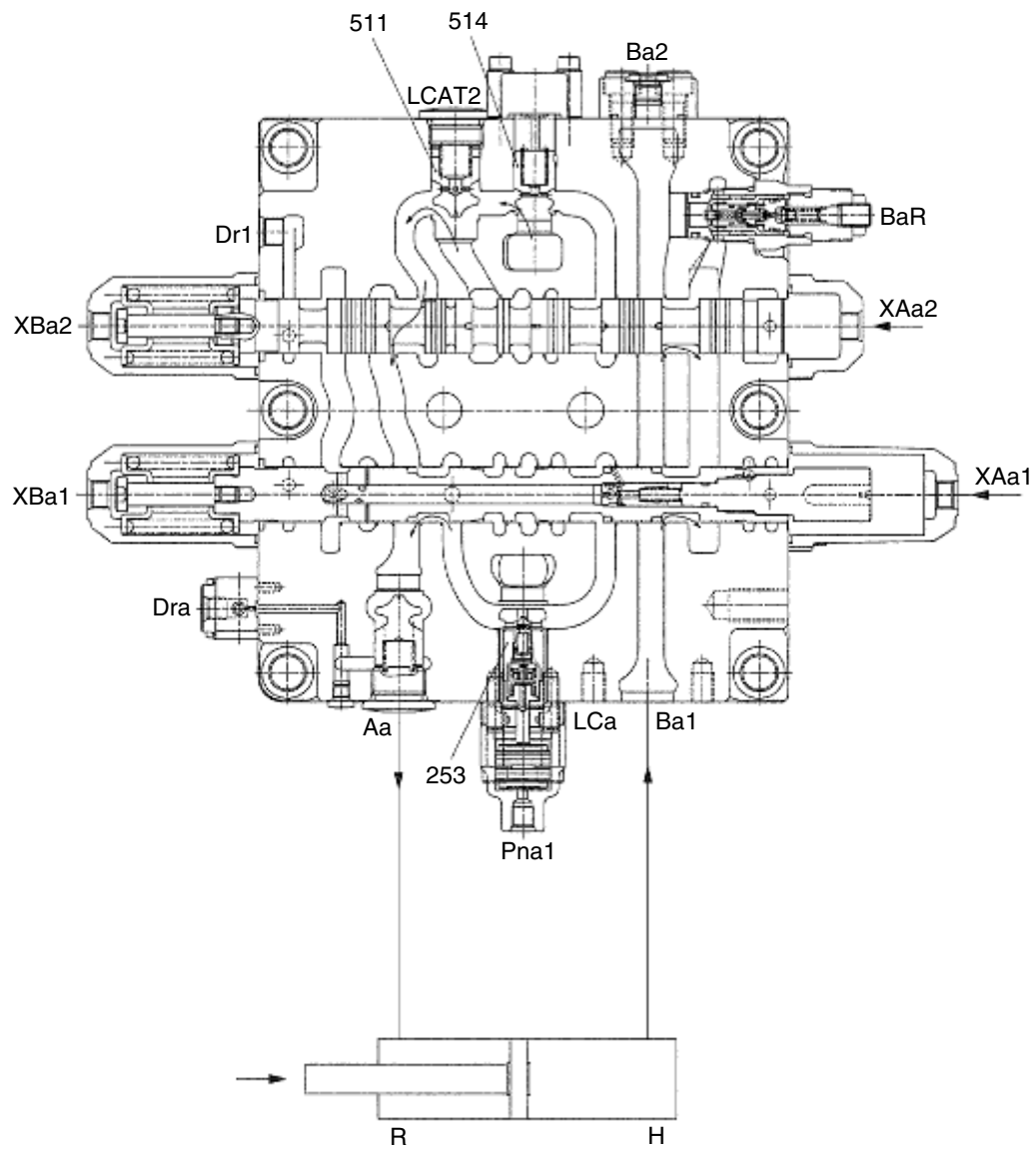

380A2MC18

(2) Arm excavating operation

① Pilot circuit

Since the arm 1 spool (302) transfers and shuts off the side-bypass path, the pressure at port Px (pressure port for attachment) increases. Then, the pressure enters also through port PaL and the release signal is sent to the lock valve selector (252).

② Main circuit

During the arm excavating operation, the pilot pressure enters through ports XBa1 and XBa2. When the pressure enters through ports XBa1 and XBa2, the arm 1 and arm 2 spools transfer in the right direction in figure. The hydraulic oil entering through port P2 passes through the main path (3) and flows to the bypass circuit (4), but the bypass circuit is shut off due to transfer of the arm 1 (302) spool. Therefore, the hydraulic oil from the parallel circuit pushes open the logic poppet (253) and flows through the U-shaped path to the arm 1 spool (302). Then, it flows around the periphery of the arm 1 spool (302) to port Ba1, and is supplied to the arm cylinder head side (H).

On the other hand, the hydraulic oil entering through port P1 passes in the main path (1), and flows into the bypass circuit (2), and the bypass circuit is shut off due to transfer of the arm 2 spool (306). The hydraulic oil from the parallel circuit pushes open the check valve (514) and oil from the bypass circuit pushes open the check valve (511) and flows through the U-shaped path to the arm 2 spool (306). Then, it flows around the periphery of arm 2 spool (306) and joins into port Ba1 through the inside path.

On the other hand, the return oil from the arm cylinder rod side (R) is pressurized by self-weight of the arms and so on, and returns to port Aa. The pressurized oil returning to port Aa enters into the spool through the outside hole (a) of the arm 1 spool (302). During a light load only, it pushes open the sleeve check valve (302-317) and joins into port Ba from the spool hole (b). This is called the arm regeneration function.

When the pressure in the arm cylinder head side (H) and the U-shaped path increases, the arm regeneration cut spool (257-103) is transferred in the left direction in Fig. ***, and at the same time the check valve (302-317) is closed by its backpressure.

This shuts off the arm regeneration function, and the return oil from the arm cylinder rod side (R) enters from port Aa through the periphery hole (a) of the arm 1 spool (302) into the spool, flows to the arm regeneration cut valve (257) through the periphery hole (c) of the arm 1 spool (302), and returns through the tank port (R1), (R3) to the hydraulic oil tank.

· During light load only

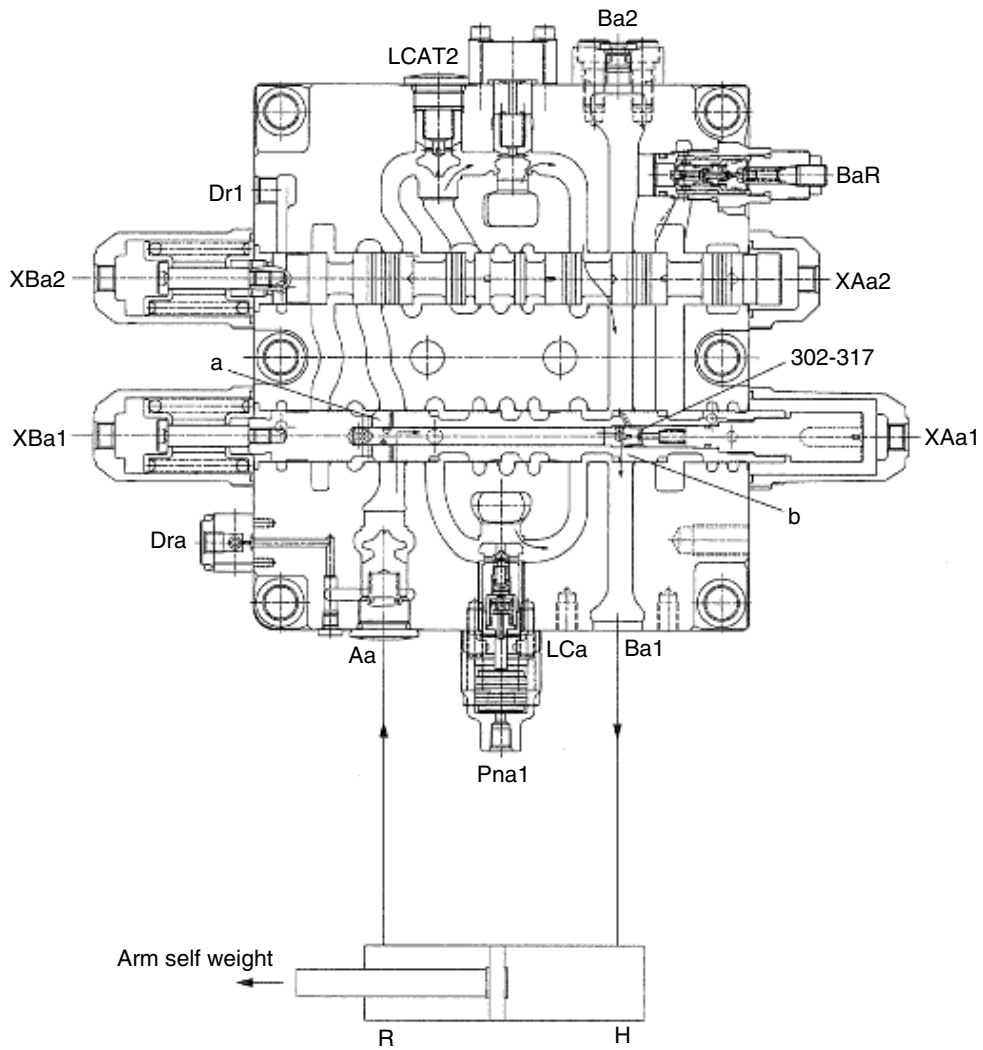

380A2MC19

- In case the pressure in the arm cylinder head side (H) increases.

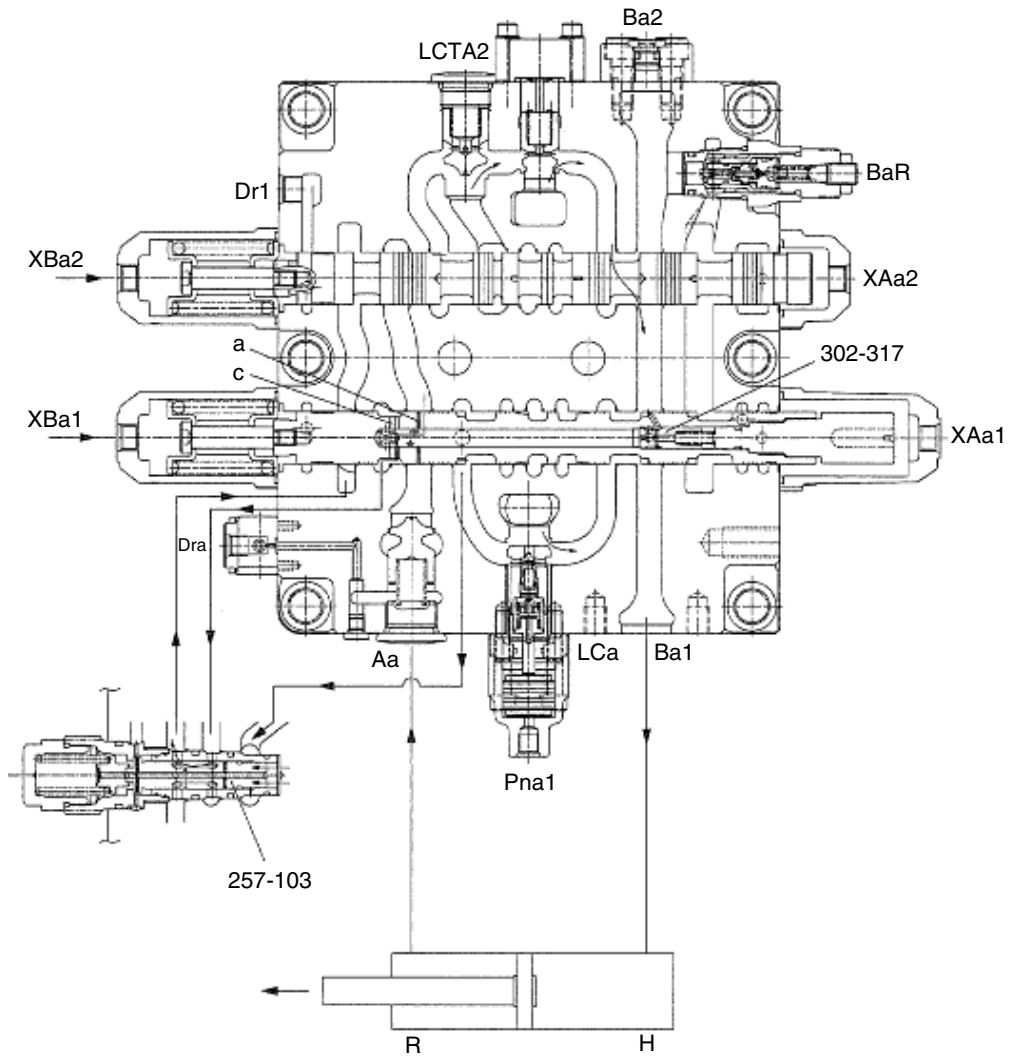

380A2MC20

4) BOOM OPERATION

(1) Boom hoisting operation

① Pilot circuit

Since the boom 2 spool (307) transfers and shuts off the side-bypass path, the pressure at port Px (Pressure port for attachment) increases.

② Main circuit

During the boom hoisting operation, the pilot pressure enters through port XAb1 and transfers the boom 1 spool (303) in the left direction in figure. The pressurized oil entering through port P1 passes through the main path (1) and flows to the bypass circuit (2), but the bypass circuit is shut off due to transfer of the boom 1 spool (303). Therefore, the pressurized oil flows into the parallel circuit, pushes open the check valve (511), and flows through U-shaped path to the boom 1 spool (303). Then, it flows around the periphery of the boom 1 spool (303) to port Ab, and is supplied to the boom cylinder head side (H).

At the same time, the pilot pressure enters also through port XAb2 to transfer the boom 2 spool (307) in the left direction in figure. Though the pressurized oil enters into port P2, the bypass circuit is shut off due to transfer of the boom 2 spool (307). Therefore, the oil flows in the parallel circuit and flows through the U-shaped path to the boom 2 spool (307). Then, the oil passes through the periphery of the boom 2 spool, pushes open the check valve (511), joins into port Ab through the inside path, and is supplied to the boom cylinder head side (H). (boom confluent flow)

On the other hand, the return oil from the boom cylinder rod side (R) enters through port Bb, passes around the periphery of the boom 1 spool (303), and returns to the hydraulic oil tank through the tank ports (R1), (R3).

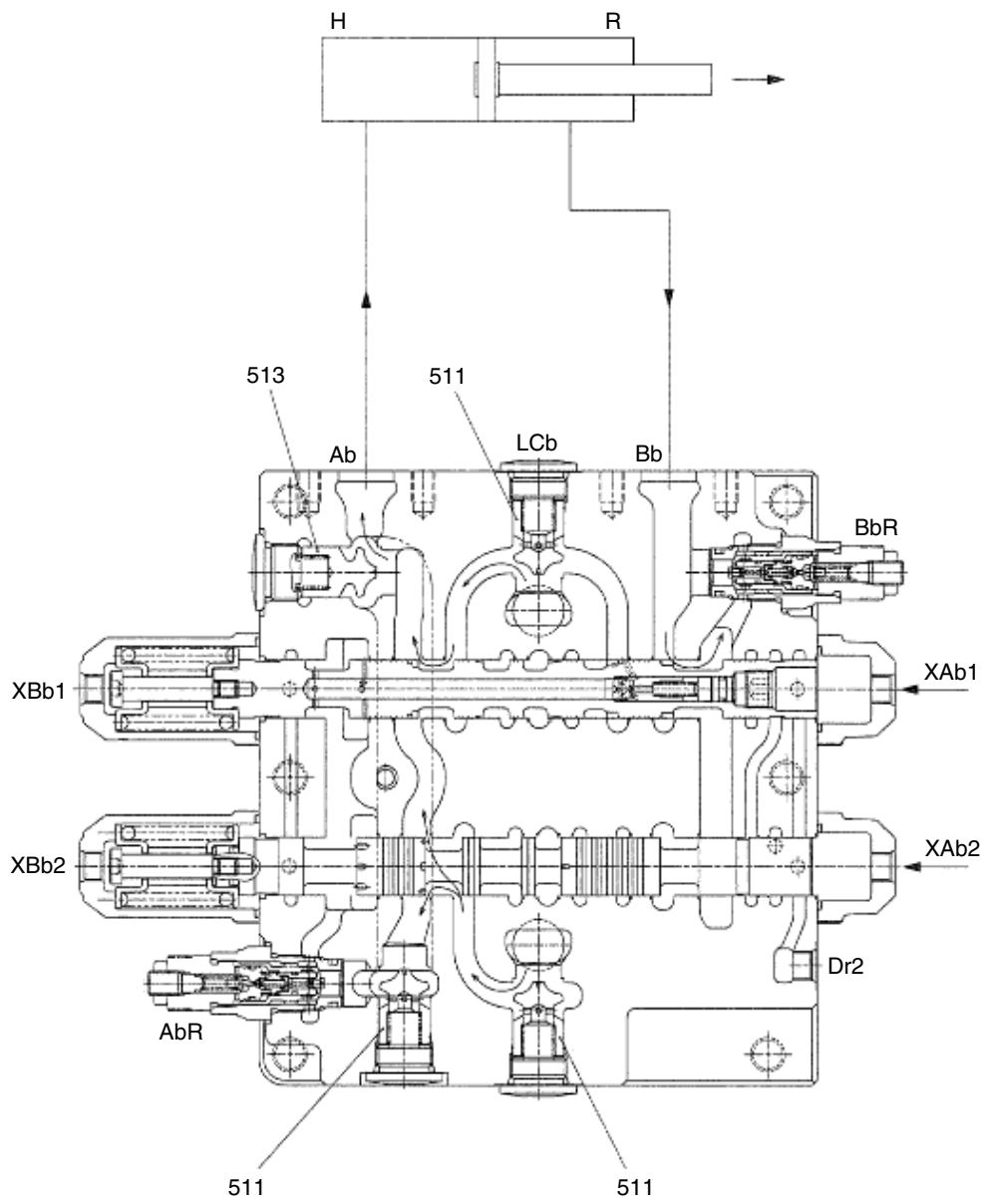

380A2MC21

(2) Boom lowering operation

① Pilot circuit

Since the boom 2 spool (307) transfers and shuts off the side-bypass path, the pressure at port Px increases. Then, the pressure enters also through port PbL and the release signal is sent to the lock valve selector (252).

② Main circuit

During the boom lowering operation, the pilot pressure enters through port XBb1 and transfers the boom 1 spool (303) in the right direction in figure. The pressurized oil entering through port P1 passes through the main path (1) and flows to the bypass circuit (2), but the bypass circuit is shut off due to transfer of the boom 1 spool (303). Therefore, the pressurized oil flows into the parallel circuit, pushes open the check valve (511), and flows through the U-shaped path to the boom 1 spool (303). Then, it flows around the periphery of the boom 1 spool (303) to port Bb and is supplied to the boom cylinder rod side (R).

On the other hand, the return oil from the boom cylinder head side (H) passes through the periphery hole (a) and the periphery of the boom 1 spool (303).

Since this return oil has a sufficient pressure caused by the weight of the boom, it passes through the path inside the spool, pushes the poppet (303-317) in the spool in the right direction shown in the figure. flows around the outside of the spool. Then, it is supplied again to the boom cylinder rod side (R) as hydraulic oil to lower the boom. (boom regeneration function)

Besides, a part of the return oil from the boom cylinder flows from the hole (b) into the tank.

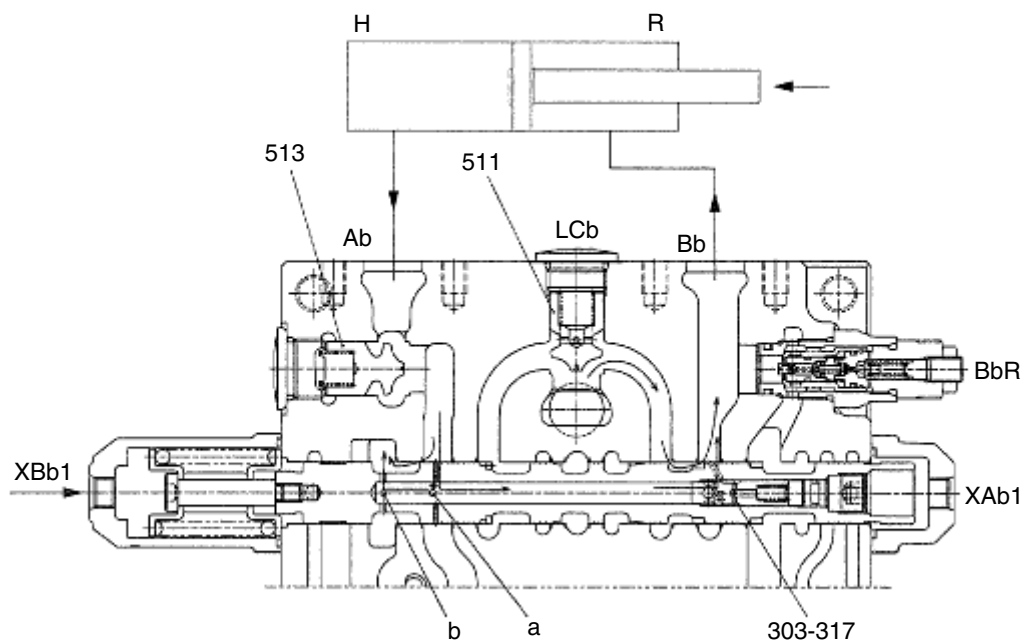

380A2MC22

5) BUCKET OPERATION

(1) Bucket excavating operation

① Pilot circuit

Since the bucket spool (304) transfers and shuts off the side-bypass path, the pressure at port Px increases. Then, the pressure enters also through port XBp2.

② Main circuit

During the bucket excavating operation, the pilot pressure enters through port XBc and transfers the bucket spool (304) in the left direction in figure. The pressurized oil entering through port P1 passes through the main path (1) and flows through the bypass circuit (2), but the bypass circuit is shut off due to transfer of the bucket spool (304). Therefore, the pressurized oil flows into the parallel circuit, pushes open the check valve (511), and flows through the U-shaped path to the bucket spool (304). Then, it flows through the periphery of the bucket spool (304) to port Bc and is supplied to the bucket cylinder head side (H).

On the other hand, the return oil from the bucket cylinder rod side (R) enters through port Ac, passes around the periphery of the spool, and returns to the hydraulic oil tank through the tank ports (R1) and (R3).

During both the boom hoisting operation and bucket excavating operation, the pilot pressure enters through port PAcs and the bucket spool transfers in the half stroke not full stroke. Therefore, the pressurized oil entering through port P1 flows to the boom 1 spool (303) preferentially to the bucket spool (304) to make the boom hoisting operation most preferential.

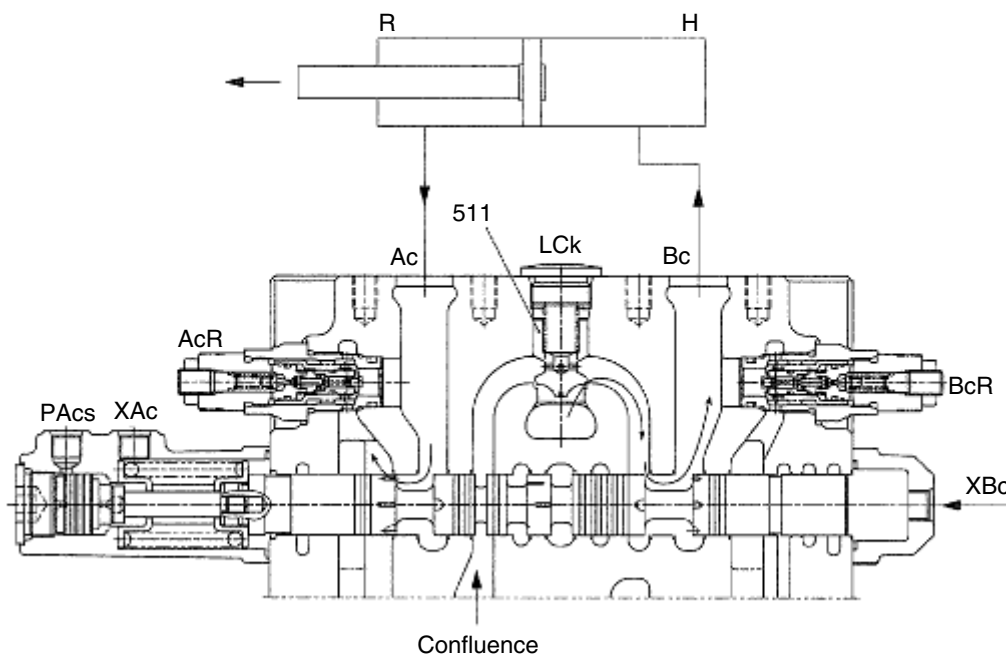

(2) Bucket releasing operation

① Pilot circuit

Since the bucket spool (304) transfers and shuts off the side-bypass path, the pressure at port Px increases. Then, the pressure enters also through port XBp2.

② Main circuit

During the bucket releasing operation, the pilot pressure enters through port XAc and transfers the bucket spool (304) in the right direction in figure. The pressurized oil entering through port P1 passes through the main path (1) and flows through the bypass circuit (2), but the bypass circuit is shut off due to transfer of the bucket spool (304). Therefore, the pressurized oil flows into the parallel circuit, pushes open the check valve (511), and flows through the U-shaped path to the bucket spool (304). Then, it flows through the periphery of the bucket spool (304) to port Ac and is supplied to the bucket cylinder rod side (R).

On the other hand, the return oil from the bucket cylinder head side (H) enters through port Bc, passes around the periphery of the spool, and returns to the hydraulic oil tank through the tank ports (R1), (R3).

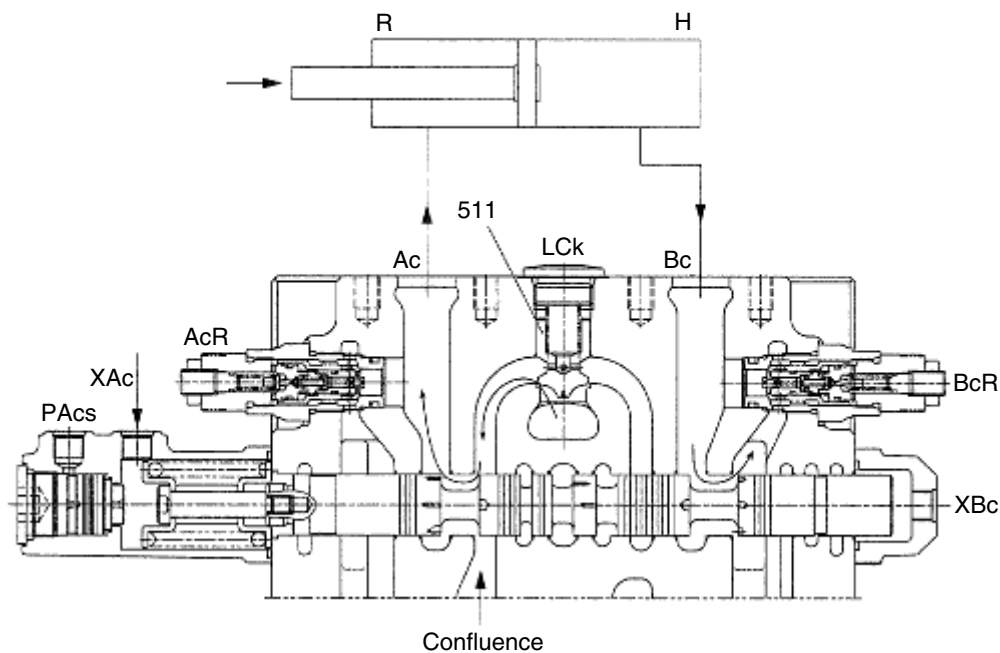

380A2MC24

③ Bucket confluence

During the bucket excavating or releasing operation, the pilot pressure enters also through port XBp2 and transfers the bypass-cut spool (310). The pressurized oil entering through port P2 passes through the main path (3) and flows through the bypass circuit (4), but the bypass circuit is shut off due to transfer of the bypass-cut spool (310). Therefore, the pressurized oil pushes open the check valve (515), and flows through inside path and the U-shaped path to the bucket spool (304).

6) SWING OPERATION

(1) Independent swing operation

① Pilot circuit

Since the swing spool (305) transfers and shuts off the side-bypass path, the pressure at port Px increases.

② Main circuit

During the swing operation, the pilot pressure enters through port XAs (or XBs) and transfers the swing spool (305). The pressurized oil entering through port P2 passes through the main path (3) and flows through the bypass circuit (4), but the bypass circuit (4) is shut off due to transfer of the swing spool (305). Therefore, the pressurized oil flows into the parallel circuit, pushes open the logic poppet (254-101), and flows through the U-shaped path to the swing spool (305). Then, it flows through the periphery of the spool to port As (or Bs) and is supplied to the swing motor.

On the other hand, the return oil from the swing motor enters port Bs (or As) and returns to the hydraulic oil tank through the tank ports (R1), (R3).

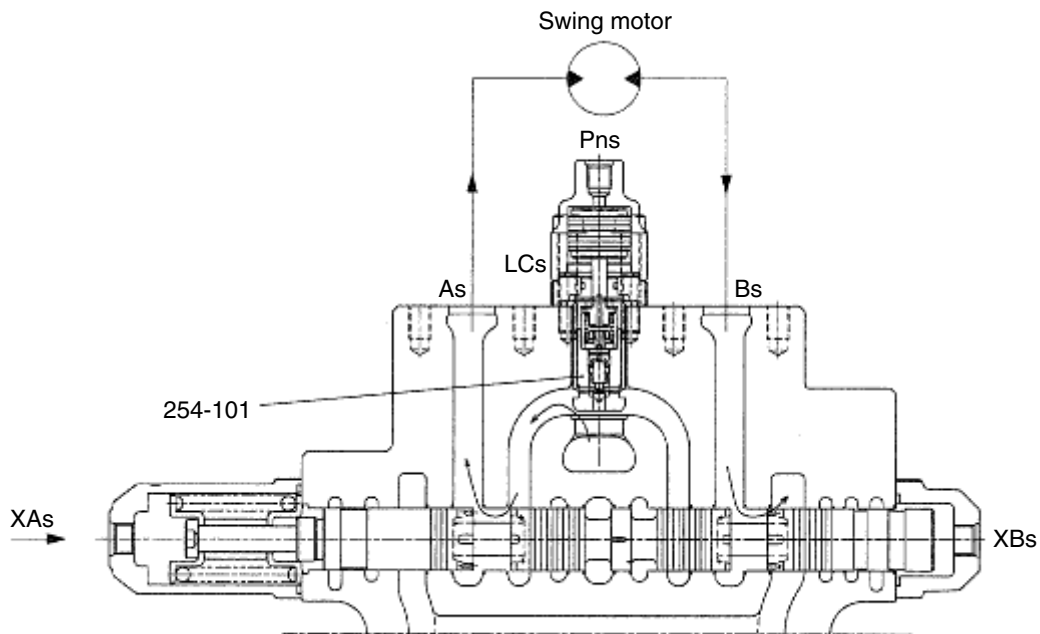

380A2MC25

(2) Swing priority function

The following is the case of making the swing operation prior to the arm excavating operation.

① Main circuit

During both the arm excavating operation and the swing operation, the swing pilot pressure enters through ports Pna1 of the logic poppet (255), and transfers the piston (255-356) and the spool (253-107) upward in figure. Therefore, the lift of the poppet (253-101) is limited, and the passage from the parallel circuit to the U-shaped path is restricted. As a result, the pressurized oil flows to the swing spool preferentially to the arm 1 spool to make the swing operation prior.

Similarly, in case the pilot pressure is applied to port Pns of the logic poppet (255), the lift of the poppet (254-101) is limited, and the boom hoisting operation is made prior to the swing operation.

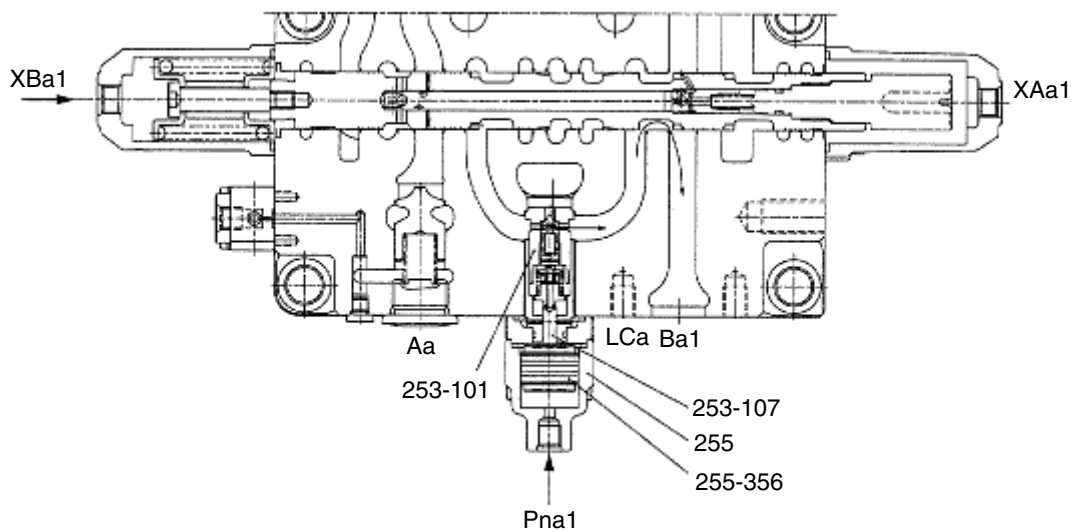

380A2MC26

7) OPTION OPERATION

This spool is used for controlling the optional attachments like a nibbler.

(1) Option operation

① Pilot circuit

Since the side bypass sections of both travel spools (301) shut off and the side bypass section of the downstream-side of swing spool shuts off, the pilot pressure from the port PG enters through the port PTb to transfer the travel straight spool (308).

② Main circuit

During the swing operation, the pilot pressure enters through port XAs (or XBs) and transfers the swing spool (305). The pressurized oil entering through port P2 passes through the main path (3) and flows through the bypass circuit (4), but the bypass circuit (4) is shut off due to transfer of the swing spool (305). Therefore, the pressurized oil flows into the parallel circuit, pushes open the logic poppet (254-101), and flows through the U-shaped path to the swing spool (305). Then, it flows through the periphery of the spool to port As (or Bs) and is supplied to the swing motor.

On the other hand, the return oil from the swing motor enters port Bs (or As) and returns to the hydraulic oil tank through the tank ports (R1), (R3).

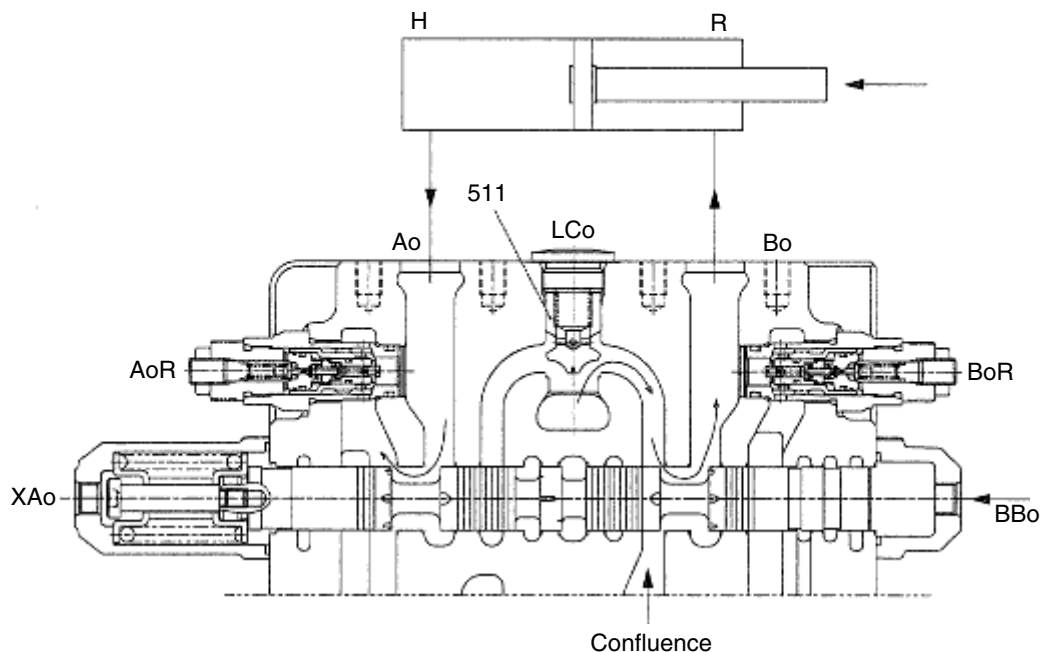

380A2MC27

(2) Option confluence

In order to use the option confluence, the pilot pressure enters through port XBp1 and transfers the bypass-cut spool (310). The pressurized oil entering through port P1 passes through the main path (1) and flows through the bypass circuit (2), but the bypass circuit (2) is shut off due to transfer of the bypass-cut spool (310). Therefore the pressurized oil pushes open the check valve (515), and flows through the inside path and the U-shaped path to the option spool (309).

8) TRAVEL STRAIGHT OPERATION

Simultaneous operating of both travel spools (301) and other spool makes the operation useful. The following is the case where both travel spools (301) and swing spool (305) are changed over. (the pilot ports XAtL, XAtR and XAs are pressurized.)

① Pilot circuit

Since the side bypass sections of both travel spools (301) shut off and the side bypass section of the downstream-side of swing spool shuts off, the pilot pressure from the port PG enters through the port PTb to transfer the travel straight spool (308).

② Main circuit

After changeover of the travel straight spool (308), the port P2 and both travel spools (301) are connected preferentially and the port P1 and the parallel paths of swing, boom 2, option and arm 1 / boom 1, bucket and arm 2 are connected preferentially. Therefore, the pressurized oil entering through port P2 passes through mainly ports AtL and Atr, and flows to both travel motors separately.

On the other hand, the pressurized oil entering through port P1 flows to port As and is supplied to the swing motor.

When the pressure of port P2 is lower than the pressure of port P1, the part of oil entering through port P1 flows into Port P2 side. Therefore, it prevents the rapid slowdown of travel.

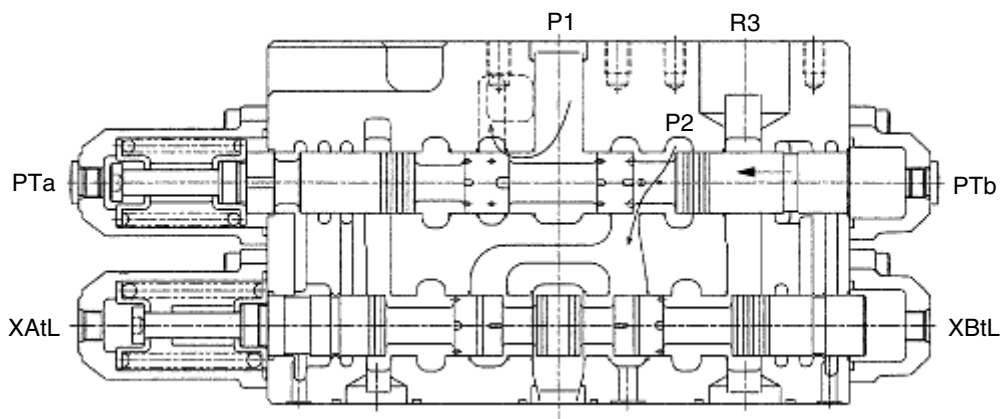

380A2MC28

9) FUNCTION OF LOCK VALVE

The lock valve (252) is installed between the arm cylinder rod side (R) and the arm 1 spool (302). It decreases the leakage by the pressure of the cylinder.

Similarly, another lock valve (252) is installed between the boom cylinder head side (H) and the boom 1 spool (303) and decreases the leakage by the pressure of the cylinder.

The following is the case of the boom cylinder head side (H).

(the case of the arm cylinder rod side (R) is in the same way.)

(1) Neutral positions of spools

During the boom 1 spool (303), boom 2 spool (307) are in the neutral position, the spool (252-511) in the lock valve is kept in the position shown in figure by the force of the spring (252-512). The spool (252-511) is pushed to the seat of the lock valve (252-101).

In this position, pressurized oil from the boom cylinder head side (H) enters through hole (a), the periphery of the spool (252-511) in the lock valve and hole (b), and it pushes the poppet (513) to the casing seat, and the leakage is decreased.

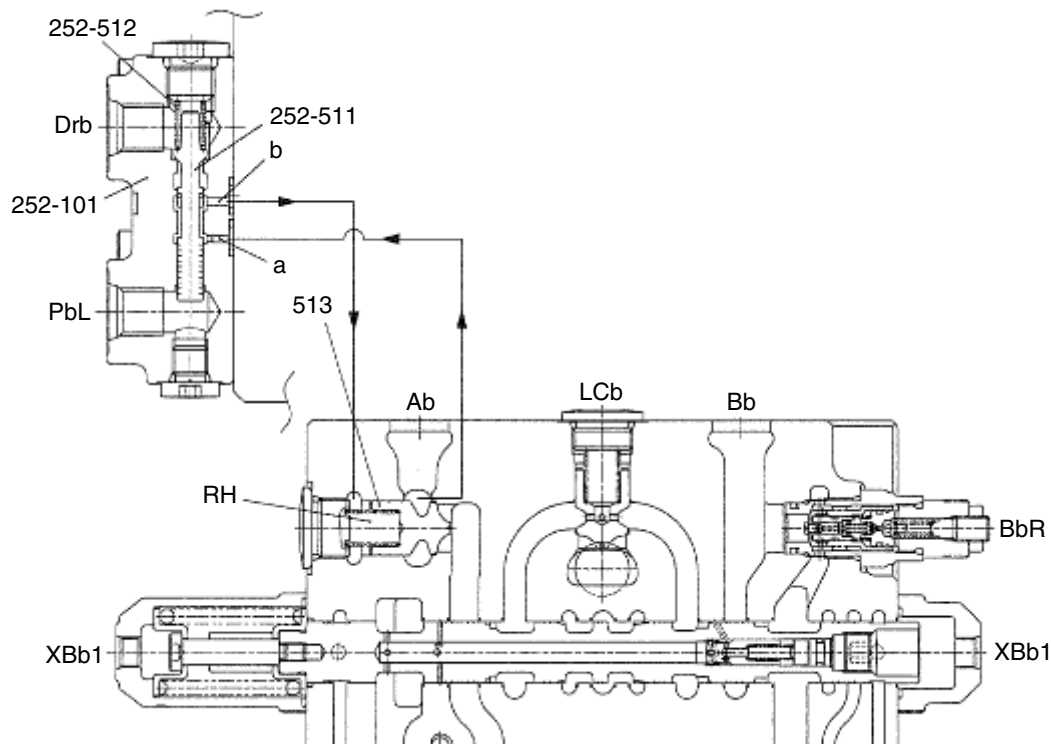

380A2MC29

(2) Boom lowering operation

During the boom lowering operation, pilot pressure enters through port PbL, XBb1 and XBb2. Pilot pressure transfers the spool (252-511) in the lock valve in the top direction in figure. By the transfer of the spool (252-511), firstly the hole (a) is blocked and pressurized oil from the boom cylinder head side (H) does not enter to spring chamber (RH). Secondly, the oil in spring chamber (RH) enters through hole (b) and flows to drain circuit. Therefore, the poppet (513) is lifted by the pressure of the boom cylinder head side (H) and the function of the lock valve (252) is released.

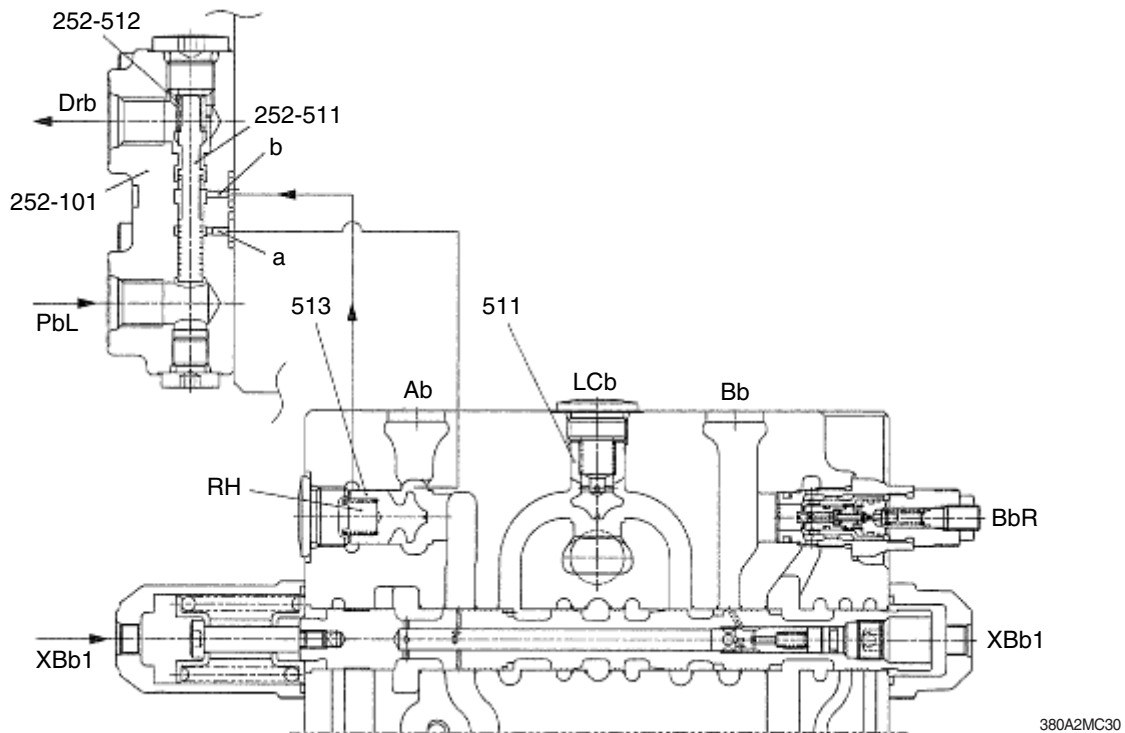

(3) Boom hoisting operation

During the boom hoisting operation, the pilot pressure enters through ports XAb1, XAb2. The oil flowing from the boom 1 spool (303) and the boom 2 spool (307) pushes open the poppet (513) and flows to port Ab.

10) FUNCTION OF MAIN RELIEF VALVEN

The main relief valve (601) is fitted in the casing A (101) and functions as follows.

- (1) The hydraulic oil is filled up in the inside space chamber (a) from the path (P) through a hole of the body (601-101) and a restriction of the plunger (601-511), and seats the plunger (601-511) against body (601-101) securely.
- (2) When the pressure in the path (P) becomes equal to the set load of the spring (601-512), the poppet (601-401) opens to make the hydraulic oil flow through a hole of the seat (601-641), around the poppet (601-401) and into the low pressure path (R).
- (3) Opening of the poppet (601-401) causes the pressure in the chamber (a) to fall and the plunger (601-511) to open. As the result the pressurized oil in the path (P) runs into the low pressure path (R) directly.
- (4) When the pressurized oil higher than pressure 3MPa enters through the port Pz, it pushes the piston (601-302) to change the relief set pressure of the spring (601-512) to the high pressure.

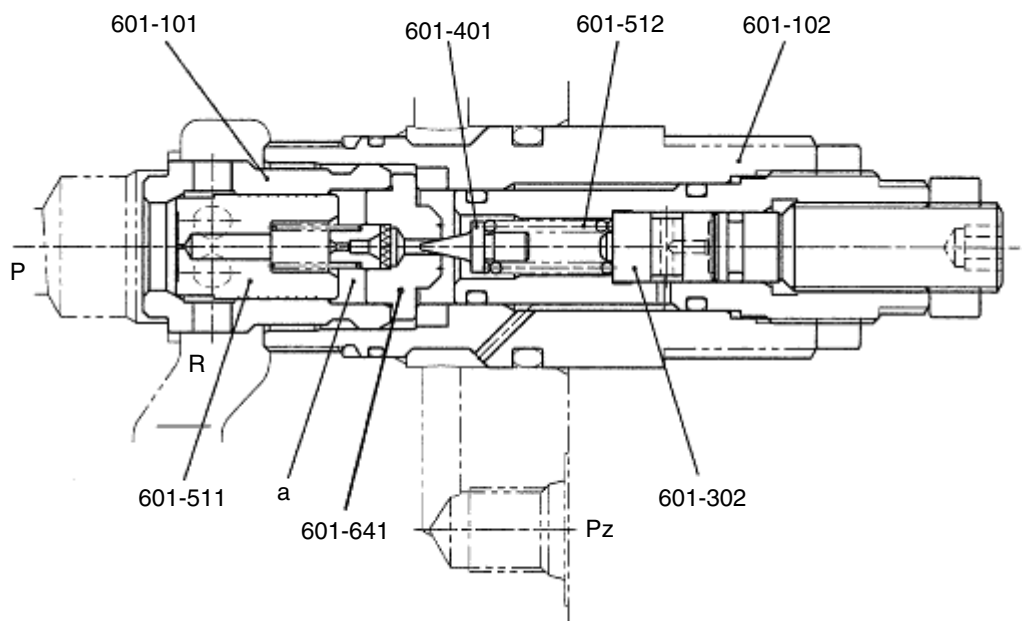

380A2MC31

11) FUNCTION OF PORT RELIEF VALVE

The port relief valve is fitted between the cylinder port and low-pressure path. In addition to the relief valve, this serves also as an anti-cavitation check valve, and functions as follows:

(1) Function as relief valve

- ① The pressurized oil passes through Hole A of the piston (301), is filled up in chamber B of the inside space, and seat the plunger (511) against the seat (541) securely.

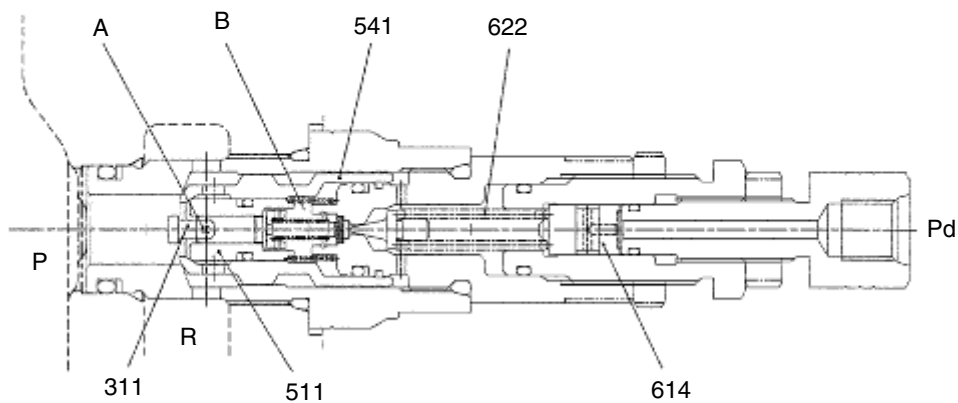
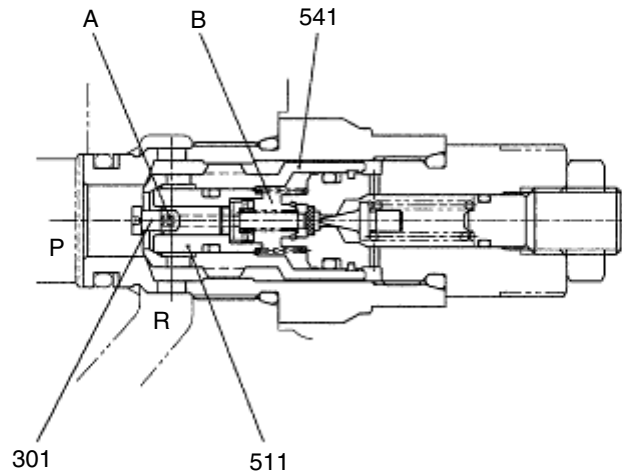

380A2MC32

- ② When the pressure in the path (P) becomes equal to the set pressure of the spring (621), the pressurized oil pushes open the poppet (611), flows around it, and flows to the low pressure path (R) through hole C.

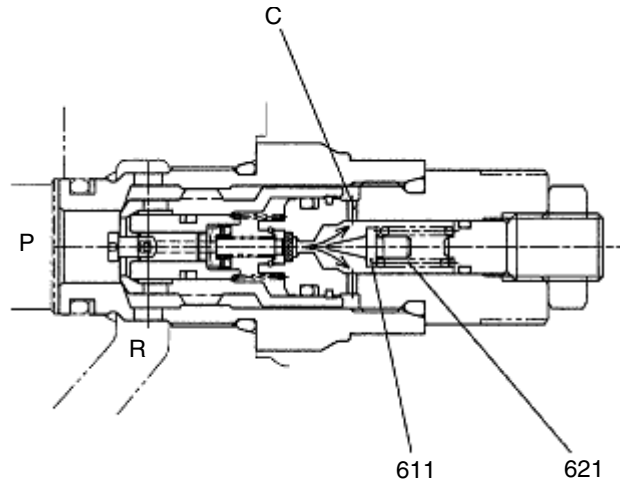

380A2MC33

- ③ Opening of the poppet (611) causes the pressure in chamber B to fall and the plunger (511) to open. As the result the pressurized oil in the path (P) runs into the low pressure path (R) directly.

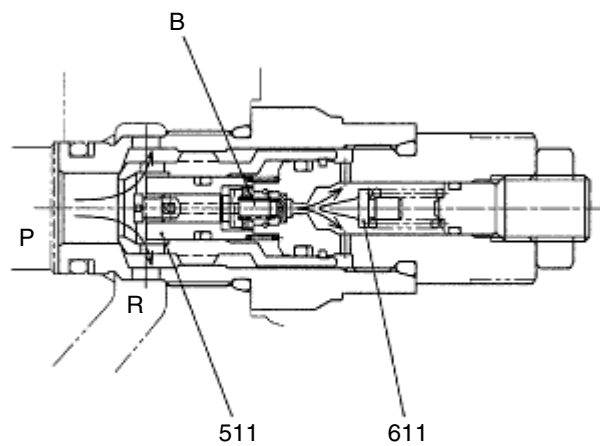

380A2MC34

(2) Function as anti-cavitation check valve

When any negative pressure exists in the path (P), the oil is supplied through the path (R). When the pressure at (R) becomes higher than that in the path (P), the seat (541) moves in the right direction.

Then, sufficient oil passes around the seat (541) from the path (R) to the path (P) and prevents cavitation.

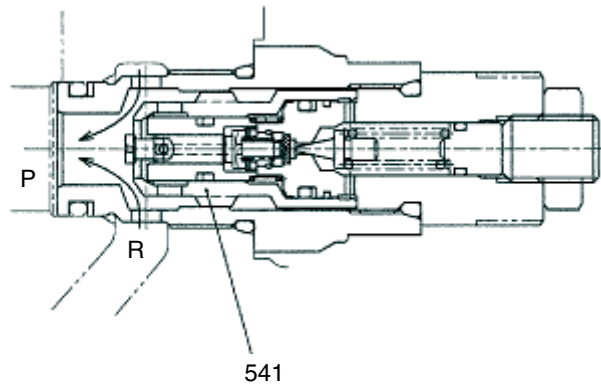

380A2MC35

(12) FUNCTION OF NEGATIVE CONTROL RELIEF VALVE

The negative control relief valve is fitted between the downstream of the center bypass path and low-pressure path, and functions as follows:

- ① When the pressure in the path (P) falls below the set level of the spring (621), the poppet (611) is in the condition shown in the figure.

The pressure acting area of the poppet (611) is reduced to $(\phi B - \phi A)$, as the area ϕB is cancelled by the area ϕA of the damping rod (631).

In this condition, the pressurized oil in the path (P) runs out to the path (R) through the orifice (C).

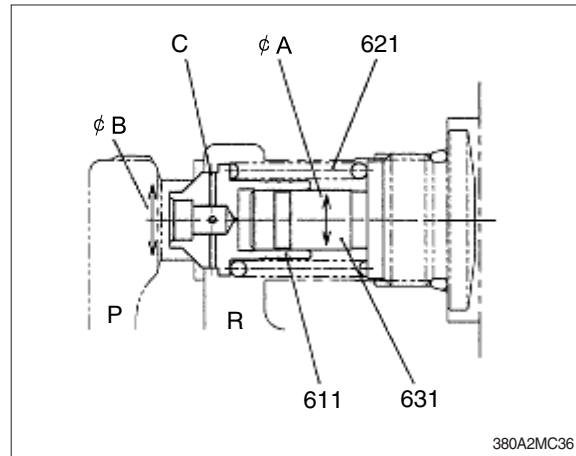

- ② When the pressure in the path (P) goes over the set pressure of the spring (621), the poppet (611) opens as shown in the figure. Then, the pressurized oil in the port P passes around the outside of the poppet (611) and flows to the low-pressure path (R).

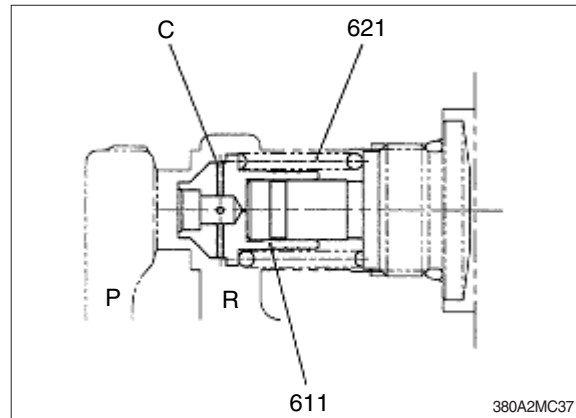

The relation between the flow rate Q and pressure P of the hydraulic oil that flows from the path (P) to the low-pressure path (R) is as shown in figure.

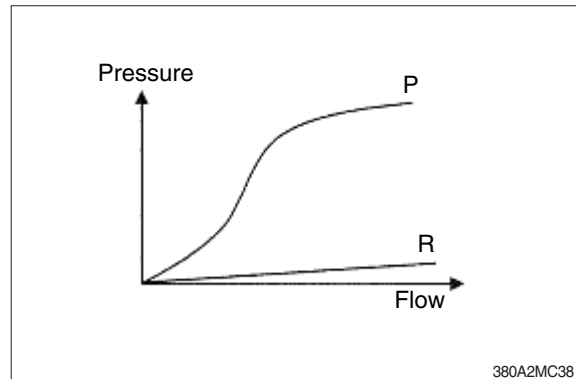

GROUP 3 SWING DEVICE (MACHINE SERIAL NO. : -#0025)

1. STRUCTURE

Swing device consists swing motor, swing reduction gear.

Swing motor include mechanical parking valve, relief valve, make up valve and time delay valve.

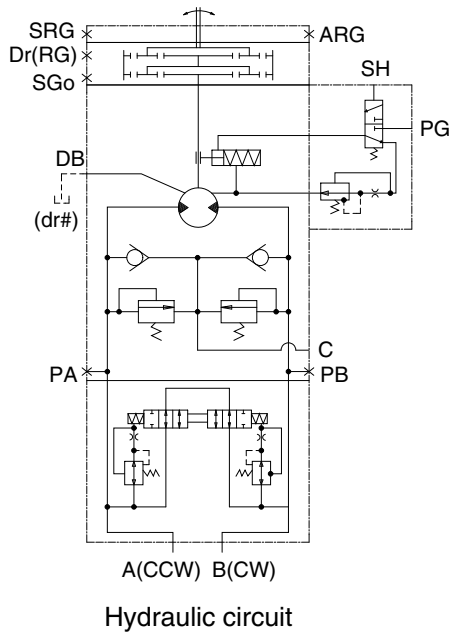
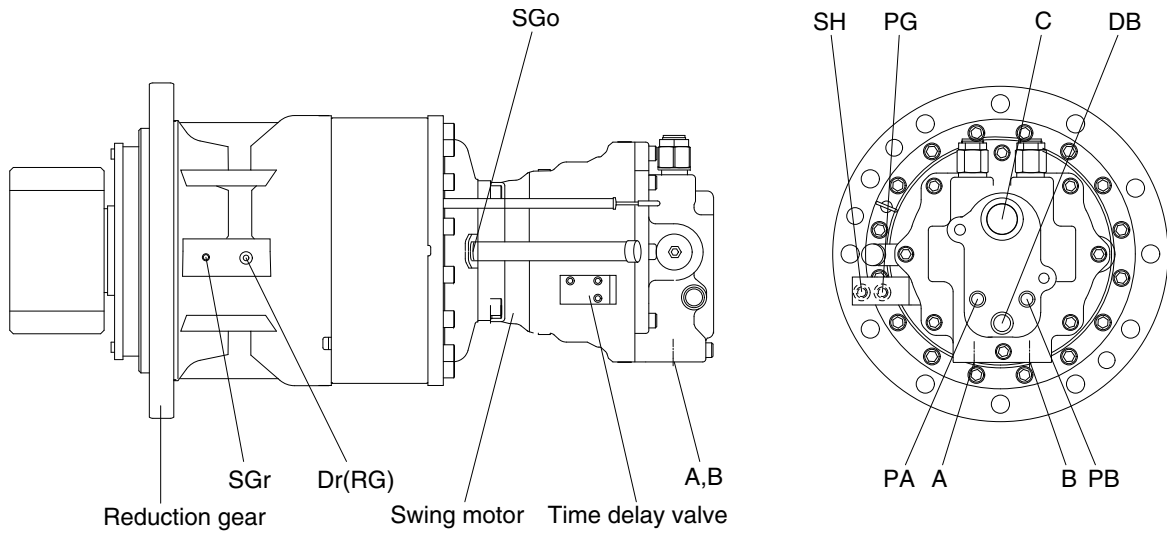

Port	Port name	Port size
A	Main port	SAE 1"
B	Main port	SAE 1"
DB	Drain port	PF 1/2
C	Make up port	PF 1 1/4
SH	Brake release pilot port	PF 1/4
PG	Brake release stand by port	PF 1/4
PA, PB	Gauge port	PF 1/4
SGr	Grease filling port	PT 1/8
Dr (R/G)	Gear oil drain port	PT 1/2
SGo	Gear oil filling port	PT 3/4

1) SWING MOTOR

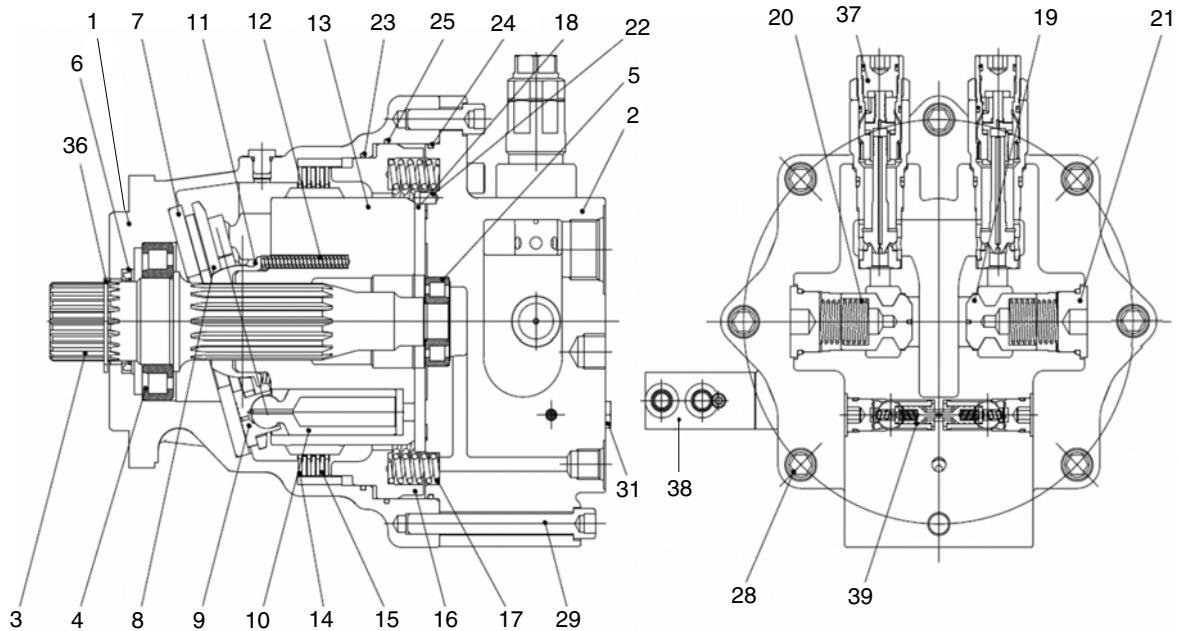

380A8SM05

- | | | | | | |
|----|----------------|----|----------------|----|--------------------|
| 1 | Casing | 13 | Separate plate | 25 | Check spring |
| 2 | Oil seal | 14 | O-ring | 26 | RO plug |
| 3 | Roller bearing | 15 | O-ring | 27 | VP plug |
| 4 | Drive shaft | 16 | Brake piston | 28 | Socket bolt |
| 5 | Swash plate | 17 | Brake spring | 29 | Socket bolt |
| 6 | Cylinder block | 18 | Plug | 30 | Relief valve |
| 7 | Spring | 19 | Valve casing | 31 | Reactionless valve |
| 8 | Thrust ball | 20 | Parallel pin | 32 | Brake valve |
| 9 | Retainer plate | 21 | Roller bearing | 33 | Socket bolt |
| 10 | Piston assy | 22 | Valve plate | 34 | Plug |
| 11 | Shoe | 23 | O-ring | | |
| 12 | Friction plate | 24 | Plunger | | |

2) REDUCTION GEAR

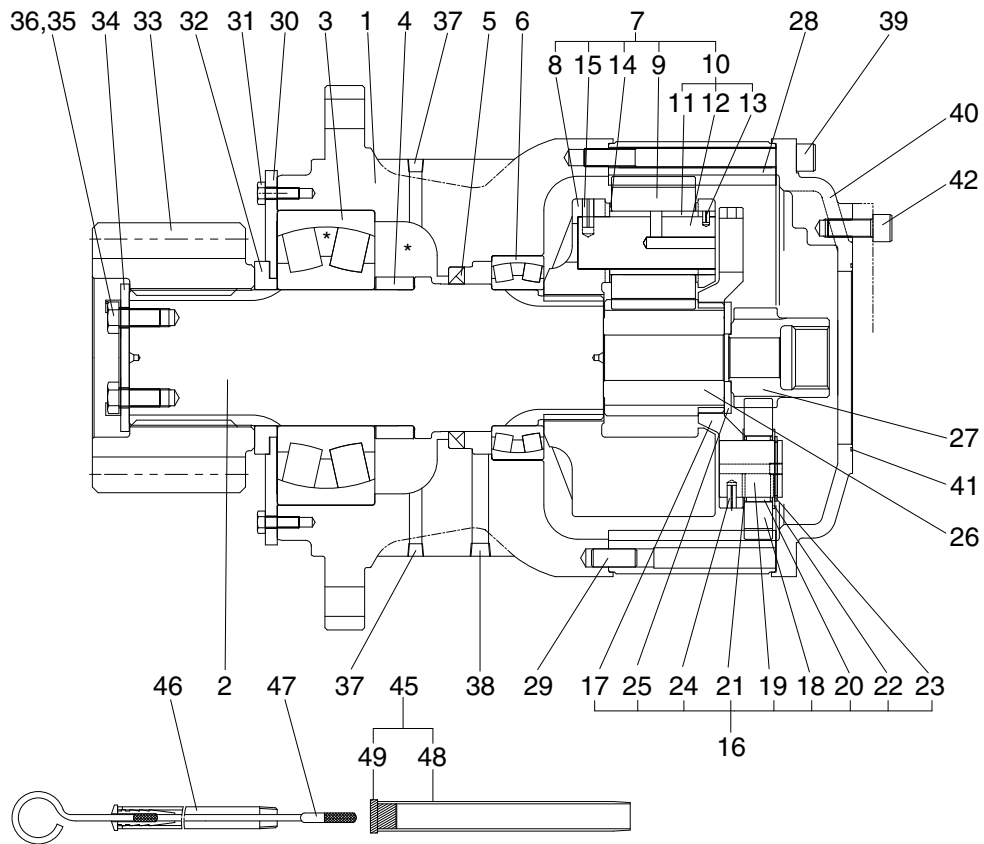

380A2SM03

1	Casing	17	Carrier 1	33	Pinion gear
2	Drive shaft	18	Planetary gear 1	34	Lock plate
3	Taper roller bearing	19	Pin 1	35	Hexagon bolt
4	Spacer ring	20	Needle cage	36	Lock washer
5	Oil seal	21	Side plate 1	37	Plug
6	Taper roller bearing	22	Side plate 2	38	Plug
7	Carrier assy 2	23	Stop ring	39	Socket bolt
8	Carrier 2 assy	24	Spring pin	40	Cover
9	Planetary gear 2	25	Thrust ring	41	O-ring
10	Pin assy 2	26	Sun gear 2	42	Hexagon socket bolt
11	Pin 2 assy	27	Sun gear 1	45	Air breather assy
12	Bushing 2	28	Ring gear	46	Gauge pipe
13	Spring pin	29	Knock pin	47	Gauge bar
14	Thrust washer	30	Cover plate	48	Air breather post
15	Spring pin	31	Hexagon bolt	49	Air breather cap
16	Carrier assy 1	32	Spacer		

2. FUNCTION

1) ROTARY PART

When high pressurized oil enters a cylinder through port (a), which is the inlet of valve plate (1), hydraulic pressure acting on the piston causes axial force F . The pressure force F works via the piston (2) upon the retainer plate (3) which acts upon the shoe plate (4) via an hydrostatic bearing. Force F_1 perpendicular to shoe plate (4) and force F_2 perpendicular to cylinder center.

Being transferred to the cylinder block (5) through piston, force F_2 causes rotational moment at surroundings of cylinder.

Since cylinder block has 9 equidistantly arrayed pistons, rotational torque is transmitted to cylinder shaft in order by several pistons connected to the inlet port of high pressurized oil. When the direction of oil flow is reversed, rotational direction of cylinder is also reversed. Output torque is given by the equation.

$$T = \frac{p \times q}{2\pi} , \quad q = Z \cdot A \cdot \text{PCD} \cdot \tan \theta , \quad F_1 = \frac{F}{\cos \theta} , \quad F_2 = F \tan \theta , \quad S = \text{PCD} \times \tan \theta$$

Where p : Effective difference of pressure (kgf/cm²)

q : Displacement (cc/rev)

T : Output torque (kgf · cm)

Z : Piston number

A : Piston area (cm²)

θ : Tilting angle of shoe plate (degree)

S : Piston stroke (cm)

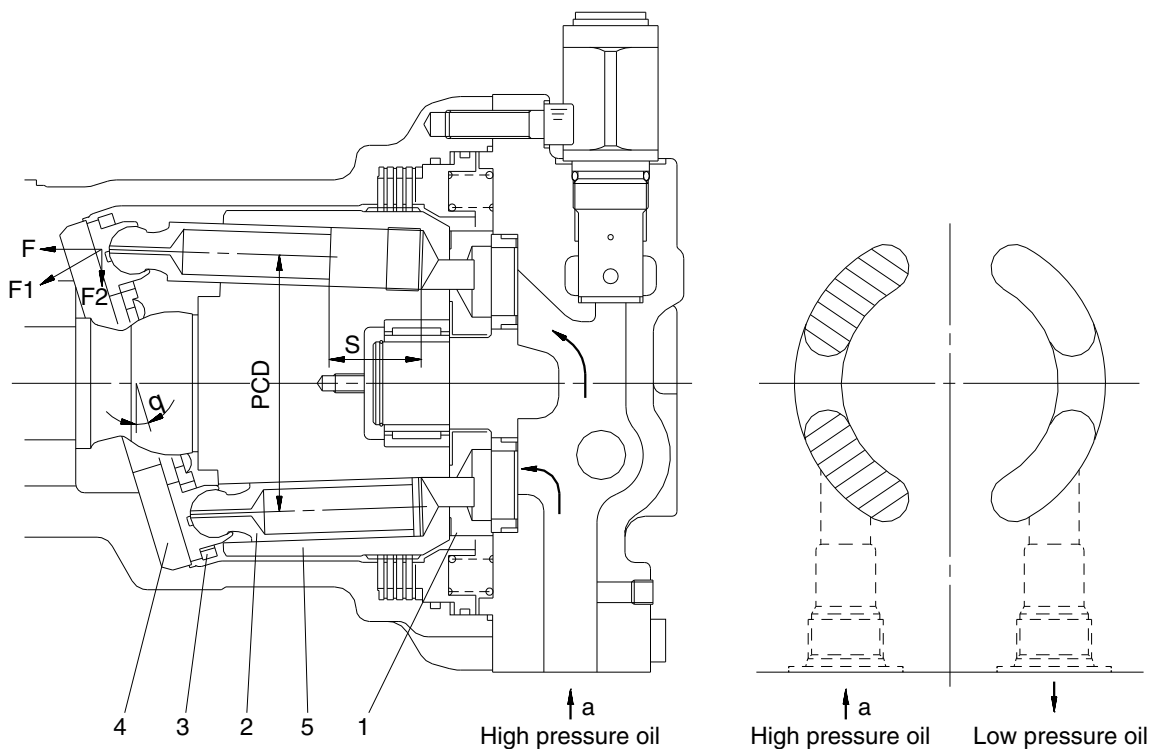

36072SM04A

2) MAKE UP VALVE

In the system using this type of motor, there is no counter balance functioning valve and there happens the case of revolution exceeding hydraulic supply of motor. To prevent the cavitation caused by insufficient oil flow there is a make up valve to fill up the oil insufficiency.

A make up valve is provided immediately before the port leading to the hydraulic oil tank to secure feed pressure required when the hydraulic motor makes a pumping action. The boost pressure acts on the hydraulic motor's feed port via the make up valve.

Pressurized oil into the port B, the motor rotate counterclockwise.

If the plunger of MCV moves neutral position, the drain oil from Mu port run into motor via right make up valve, which prevent the cavitation of motor.

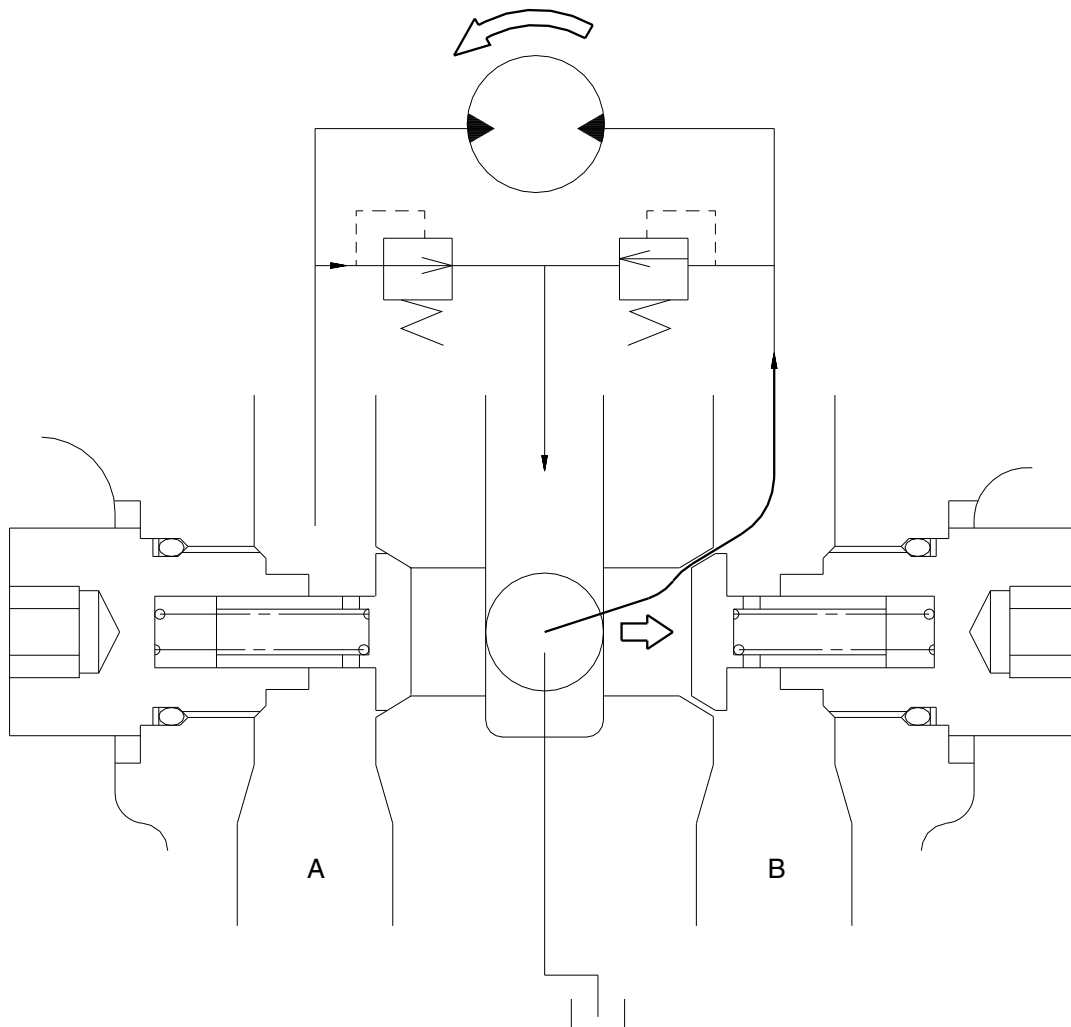

36072SM05

3) RELIEF VALVE

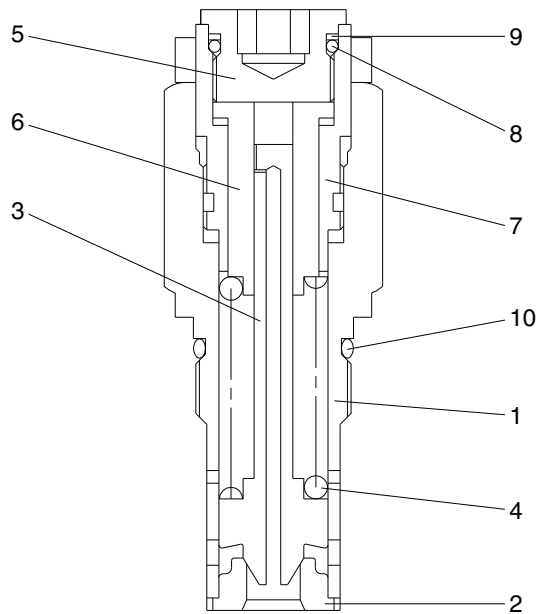

- 1 Body
- 2 Seat
- 3 Plunger
- 4 Spring
- 5 Adjusting screw
- 6 Piston
- 7 Sleeve
- 8 O-ring
- 9 Back up ring
- 10 O-ring

36072SM06

(1) Construction of relief valve

The valve casing contains two cartridge type relief valves that stop the regular and reverse rotations of the hydraulic motor. The relief valves relieve high pressure at start or at stop of swing motion and can control the relief pressure in two steps, high and low, in order to insure smooth operation.

(2) Function of relief valve

Figure illustrates how the pressure acting on the relief valve is related to its rising process. Here is given the function, referring to the figure following page.

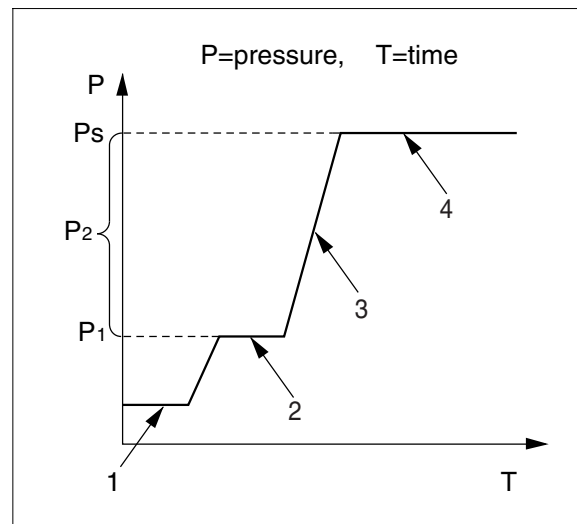

2-51(2) [360-7]

① Ports (P, R) at tank pressure.

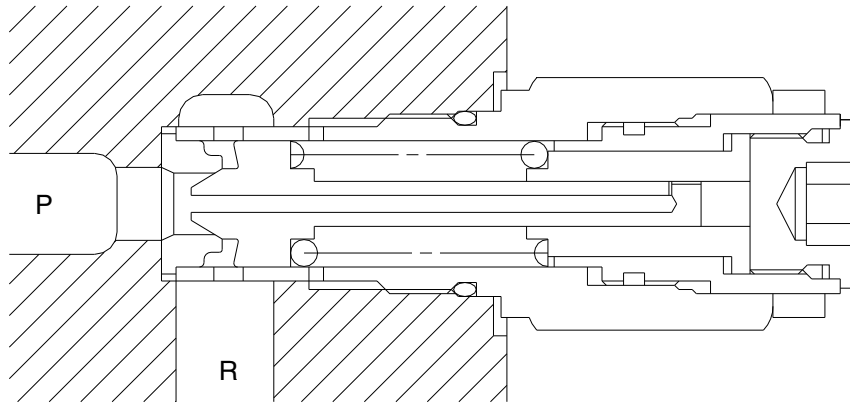

36072SM07

② When hydraulic oil pressure ($P \times A_1$) reaches the preset force (F_{SP}) of spring (4), the plunger (3) moves to the right as shown.

$$P_1 \times A_1 = F_{SP} + P_g \times A_2$$

$$P_1 = \frac{F_{SP} + P_g \times A_2}{A_1}$$

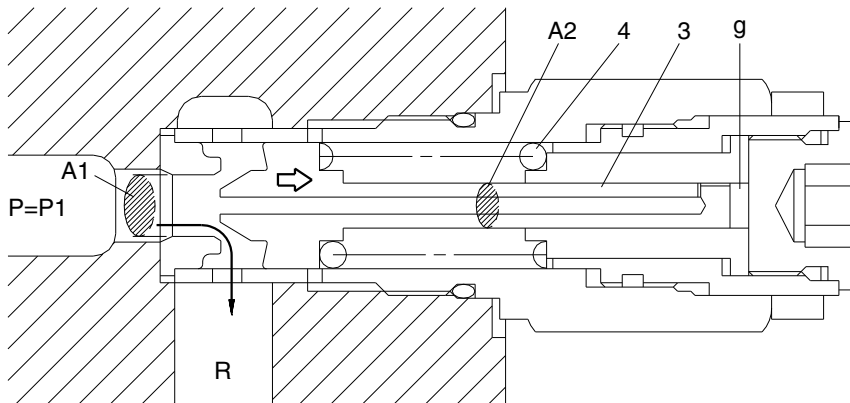

36072SM08

- ③ The oil flow chamber g via orifice m and n. When the pressure chamber g reaches the preset force (F_{sp}) of spring (4), the piston (6) moves left and stop the piston (6) hits the bottom of sleeve (7).

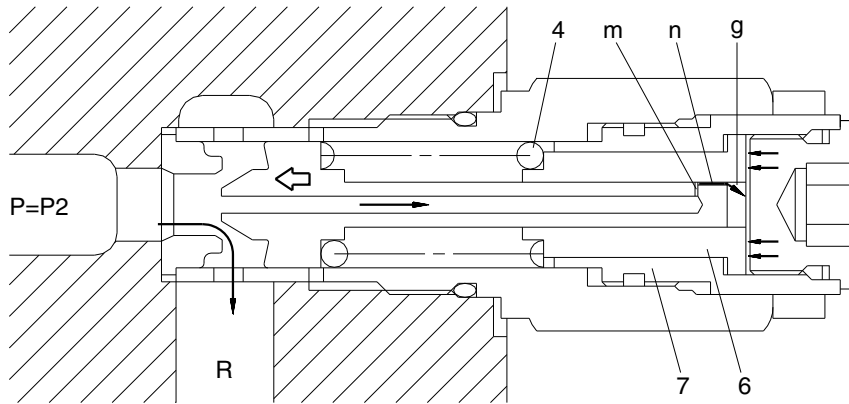

36072SM09

- ④ When piston (6) hits the end of sleeve (7), it stops moving to the left any further. As the result, the pressure in chamber (g) equals (P_s).

$$P_s \times A_1 = F_{sp} + P_s \times A_2$$

$$P_s = \frac{F_{sp}}{A_1 - A_2}$$

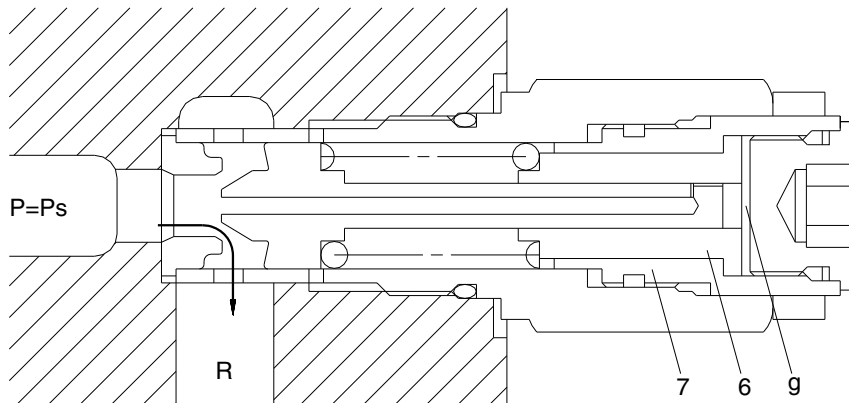

36072SM10

4) BRAKE SYSTEM

(1) Control valve swing brake system

This is the brake system to stop the swing motion of the excavator for during operation. In this system, the hydraulic circuit is throttled by the swing control valve, and the resistance created by this throttling works as a brake force to slow down the swing motion.

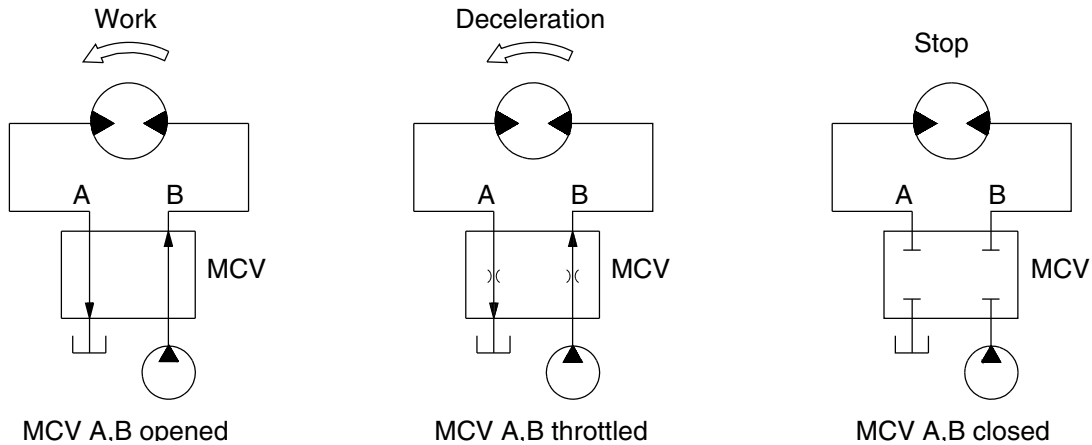

R130SM05

(2) Mechanical swing parking brake system

The mechanical swing parking brake system is installed to prevent the upper structure from swinging downhill because of its own weight when the excavator is parked on a slope since it completely eliminates the hydraulic drift of swing motion while the excavator is on a slope, work can be done more easily and safely.

① Brake assembly

Circumferential rotation of separate plate (13) is constrained by the groove located at casing (1). When housing is pressed down by brake spring (17) through friction plate (12), separate plate (13) and brake piston (16), friction force occurs there.

Cylinder block (6) is constrained by this friction force and brake acts, while brake releases when hydraulic force exceeds spring force.

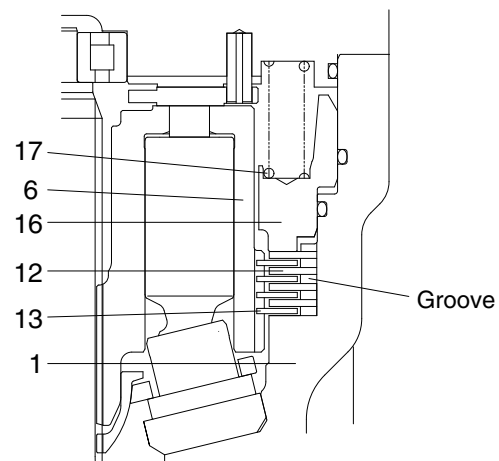

400A2SM11

1	Casing	13	Separate plate
6	Cylinder block	16	Brake piston
12	Friction plate	17	Brake spring

② Operating principle

- a. When one of the RCV lever (1) is set to the operation position, the each spool is shifted to left or right and the pilot oil flow is blocked. Then the pilot oil go to SH of the brake valve (3). This pressure moves spool (5) to the leftward against the force of the spring(8), so pilot pump charged oil (P3) goes to the chamber G through port PG. This pressure is applied to move the piston (6) to the upward against the force of the spring (9). Thus, it releases the brake force.

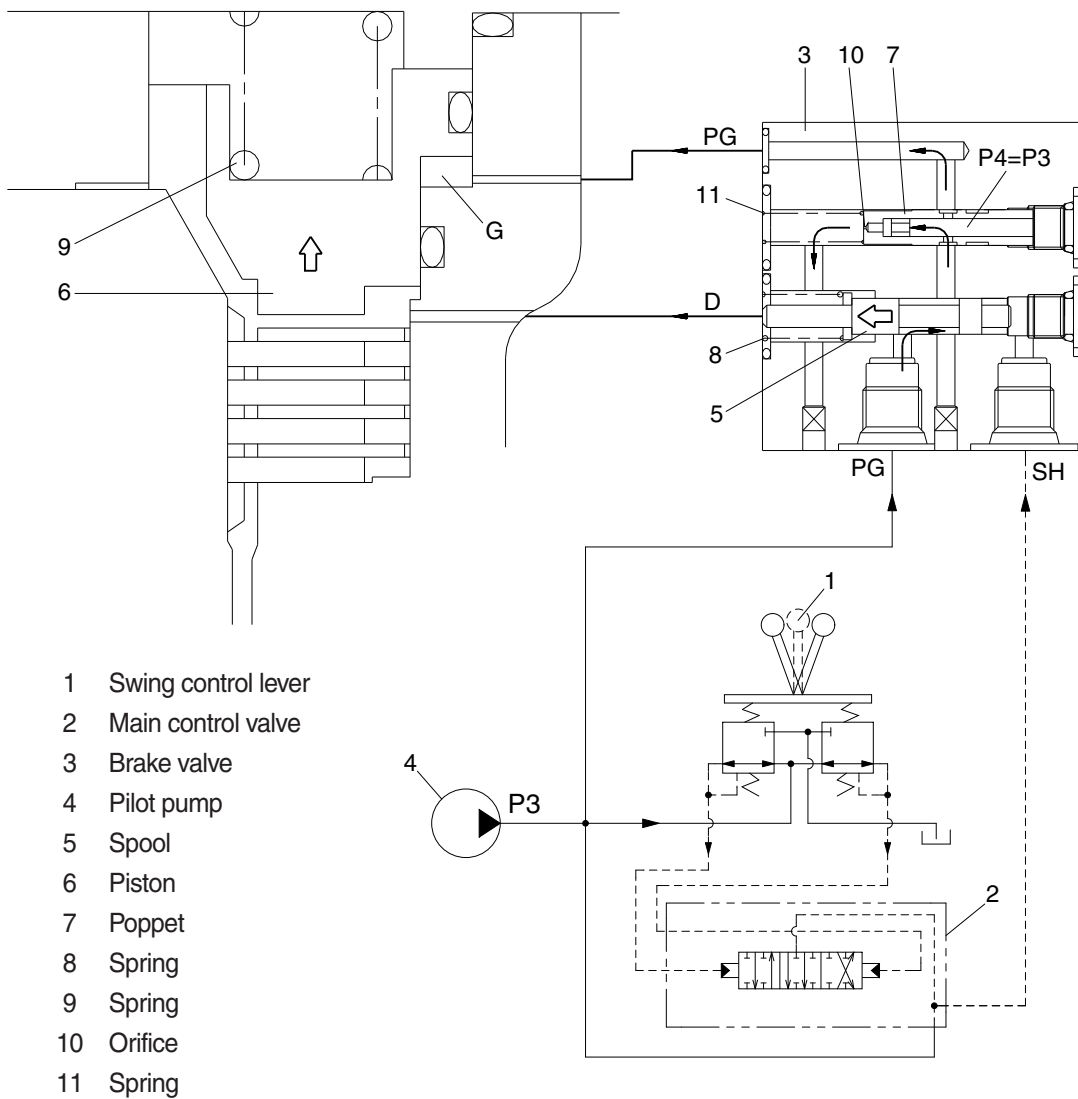

36072SM12

- b. When all of the RCV lever (1) are set the neutral position, the spool (5) returns to right. Then, the piston (6) is moved lower by spring force and the return oil from the chamber G flows back to tank port. At this time, the brake works.

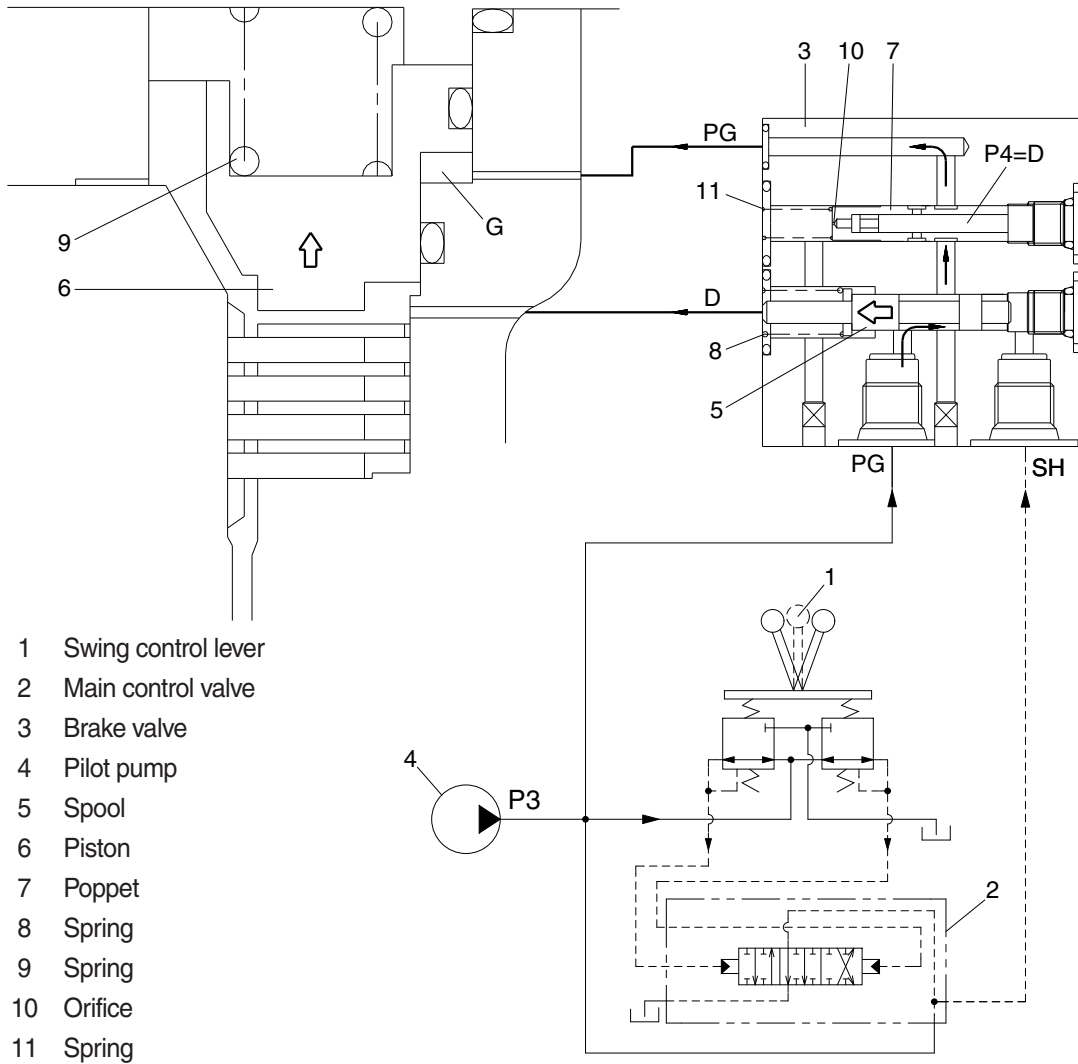

36072SM13A

- c. When the swing control (1) lever is set the neutral position the spool (5) returns right in the brake valve (3).
 Then, the piston (6) is moved lower by spring force and the return and the return oil from the chamber G flows back to D-port through orifice (10) of the poppet (7).
 At this time, the poppet (7) works to make a time lag for 5 seconds.

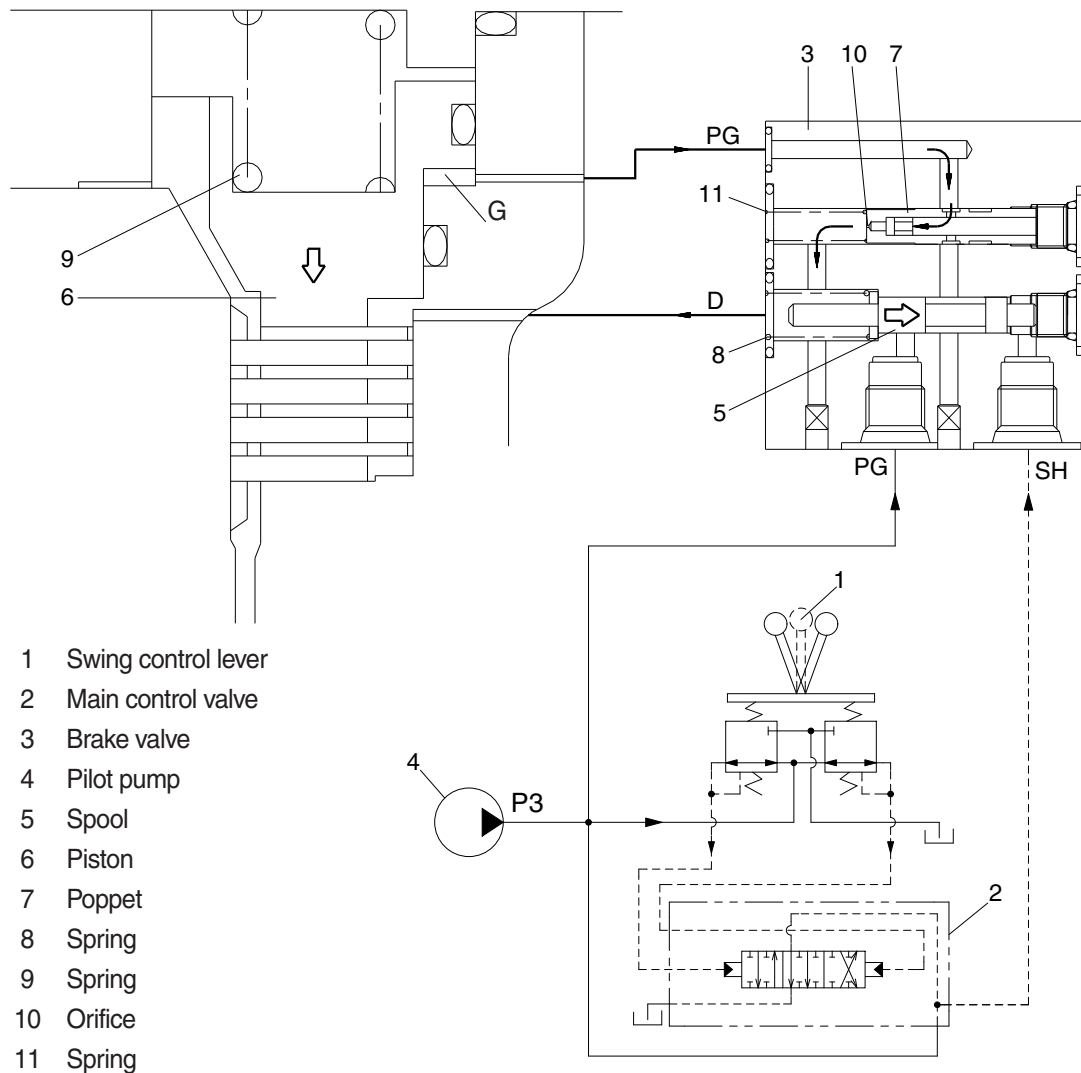

38092SM04

SWING DEVICE (MACHINE SERIAL NO. : #0026-)

1. STRUCTURE

Swing device consists swing motor, swing reduction gear.

Swing motor include mechanical parking valve, relief valve, make up valve and brake valve.

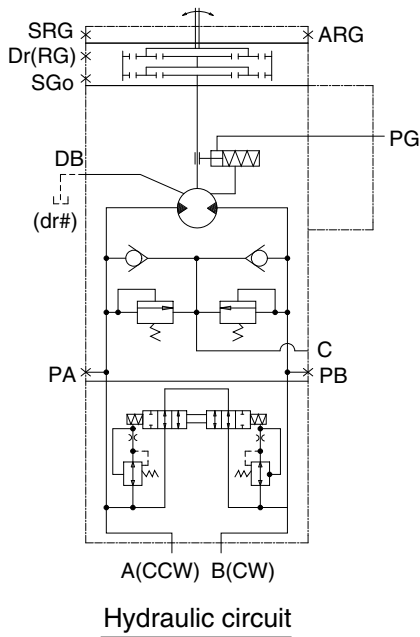
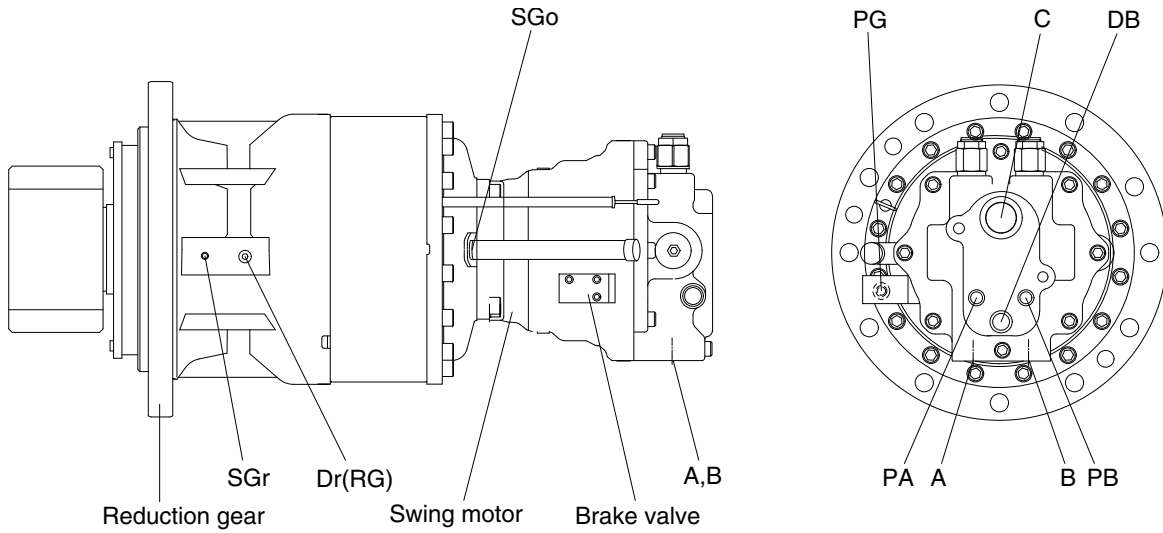

Port	Port name	Port size
A	Main port	SAE 1"
B	Main port	SAE 1"
DB	Drain port	PF 1/2
C	Make up port	PF 1 1/4
PG	Brake release port	PF 1/4
PA, PB	Gauge port	PF 1/4
SGr	Grease filling port	PT 1/8
Dr (R/G)	Gear oil drain port	PT 1/2
SGo	Gear oil filling port	PT 3/4

1) SWING MOTOR

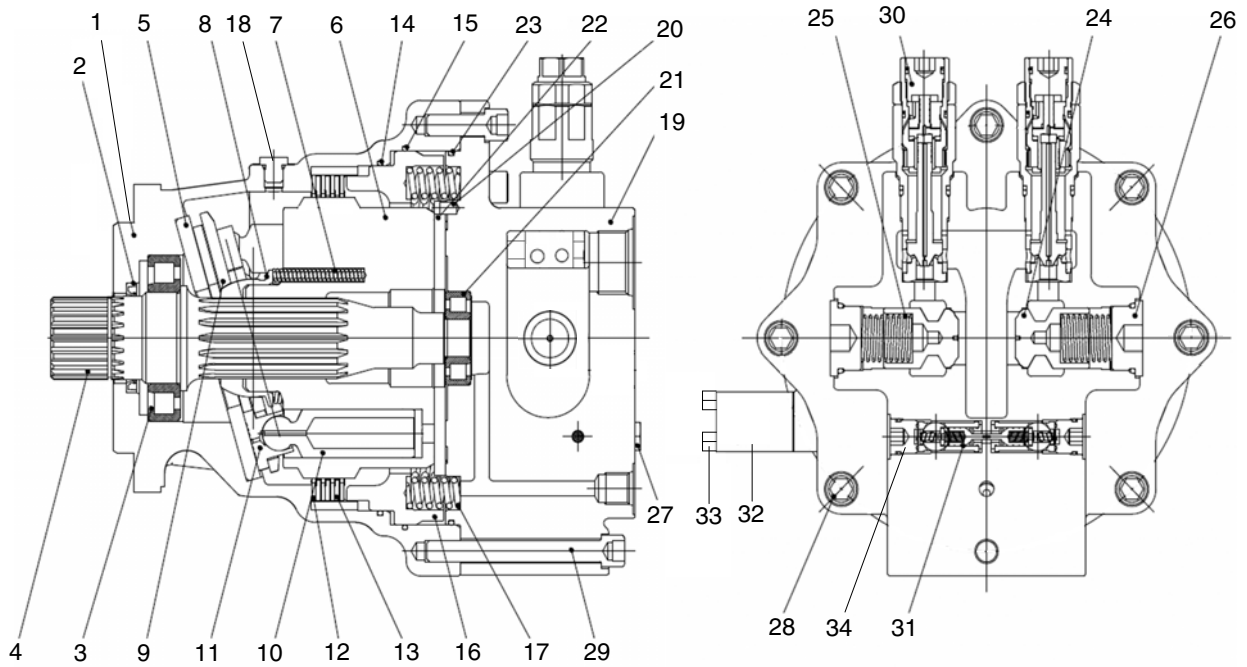

400A2SM05

- | | | | | | |
|----|----------------|----|----------------|----|--------------------|
| 1 | Casing | 13 | Separate plate | 25 | Check spring |
| 2 | Oil seal | 14 | O-ring | 26 | HS plug |
| 3 | Roller bearing | 15 | O-ring | 27 | HH plug |
| 4 | Drive shaft | 16 | Brake piston | 28 | Socket bolt |
| 5 | Swash plate | 17 | Brake spring | 29 | Socket bolt |
| 6 | Cylinder block | 18 | Plug | 30 | Relief valve |
| 7 | Spring | 19 | Valve casing | 31 | Reactionless valve |
| 8 | Thrust ball | 20 | Parallel pin | 32 | Brake valve |
| 9 | Retainer plate | 21 | Roller bearing | 33 | Hex bolt |
| 10 | Piston assy | 22 | Valve plate | 34 | Plug |
| 11 | Shoe | 23 | O-ring | | |
| 12 | Friction plate | 24 | Plunger | | |

2) REDUCTION GEAR

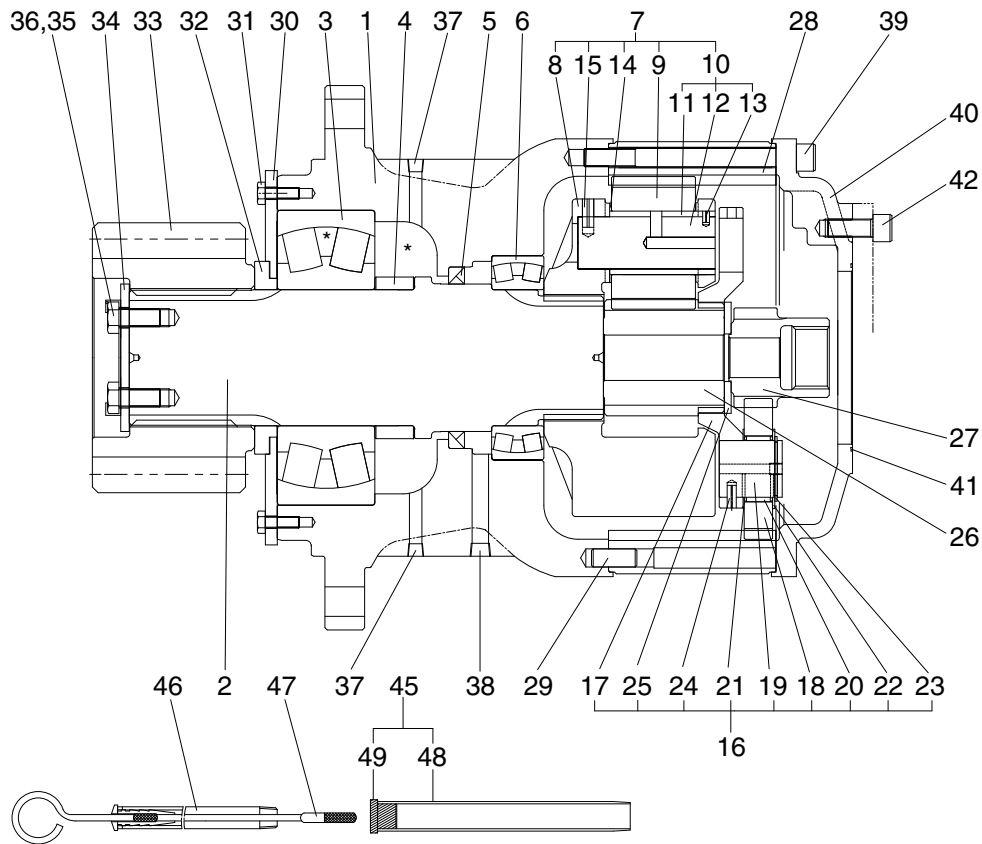

380A2SM03

1	Casing	17	Carrier 1	33	Pinion gear
2	Drive shaft	18	Planetary gear 1	34	Lock plate
3	Taper roller bearing	19	Pin 1	35	Hexagon bolt
4	Spacer ring	20	Needle cage	36	Lock washer
5	Oil seal	21	Side plate 1	37	Plug
6	Taper roller bearing	22	Side plate 2	38	Plug
7	Carrier assy 2	23	Stop ring	39	Socket bolt
8	Carrier 2 assy	24	Spring pin	40	Cover
9	Planetary gear 2	25	Thrust ring	41	O-ring
10	Pin assy 2	26	Sun gear 2	42	Hexagon socket bolt
11	Pin 2 assy	27	Sun gear 1	45	Air breather assy
12	Bushing 2	28	Ring gear	46	Gauge pipe
13	Spring pin	29	Knock pin	47	Gauge bar
14	Thrust washer	30	Cover plate	48	Air breather post
15	Spring pin	31	Hexagon bolt	49	Air breather cap
16	Carrier assy 1	32	Spacer		

2. FUNCTION

1) ROTARY PART

When high pressurized oil enters a cylinder through port (a), which is the inlet of valve plate (1), hydraulic pressure acting on the piston causes axial force F . The pressure force F works via the piston (2) upon the retainer plate (3) which acts upon the shoe plate (4) via an hydrostatic bearing. Force F_1 perpendicular to shoe plate (4) and force F_2 perpendicular to cylinder center.

Being transferred to the cylinder block (5) through piston, force F_2 causes rotational moment at surroundings of cylinder.

Since cylinder block has 9 equidistantly arrayed pistons, rotational torque is transmitted to cylinder shaft in order by several pistons connected to the inlet port of high pressurized oil. When the direction of oil flow is reversed, rotational direction of cylinder is also reversed. Output torque is given by the equation.

$$T = \frac{p \times q}{2\pi} , q = Z \cdot A \cdot \text{PCD} \cdot \tan \theta , F_1 = \frac{F}{\cos \theta} , F_2 = F \tan \theta , S = \text{PCD} \times \tan \theta$$

Where p : Effective difference of pressure (kgf/cm²)

q : Displacement (cc/rev)

T : Output torque (kgf · cm)

Z : Piston number

A : Piston area (cm²)

θ : Tilting angle of shoe plate (degree)

S : Piston stroke (cm)

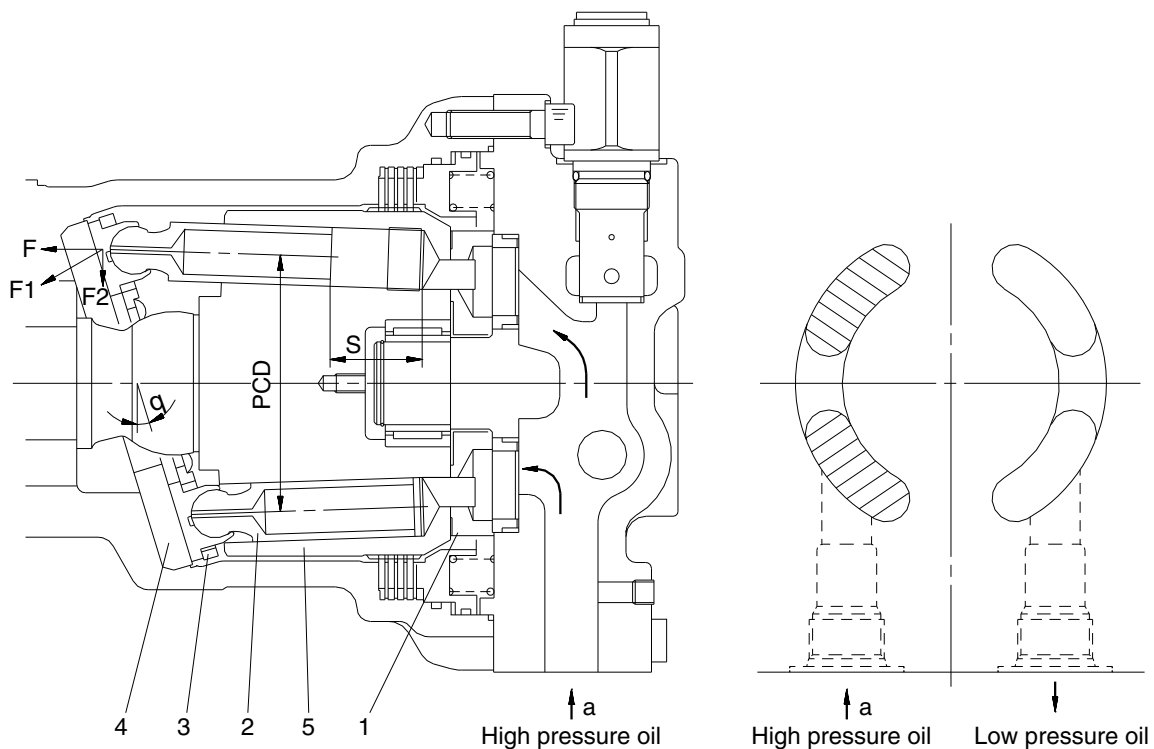

36072SM04A

2) MAKE UP VALVE

In the system using this type of motor, there is no counter balance functioning valve and there happens the case of revolution exceeding hydraulic supply of motor. To prevent the cavitation caused by insufficient oil flow there is a make up valve to fill up the oil insufficiency.

A make up valve is provided immediately before the port leading to the hydraulic oil tank to secure feed pressure required when the hydraulic motor makes a pumping action. The boost pressure acts on the hydraulic motor's feed port via the make up valve.

Pressurized oil into the port B, the motor rotate counterclockwise.

If the plunger of MCV moves neutral position, the drain oil from Mu port run into motor via right make up valve, which prevent the cavitation of motor.

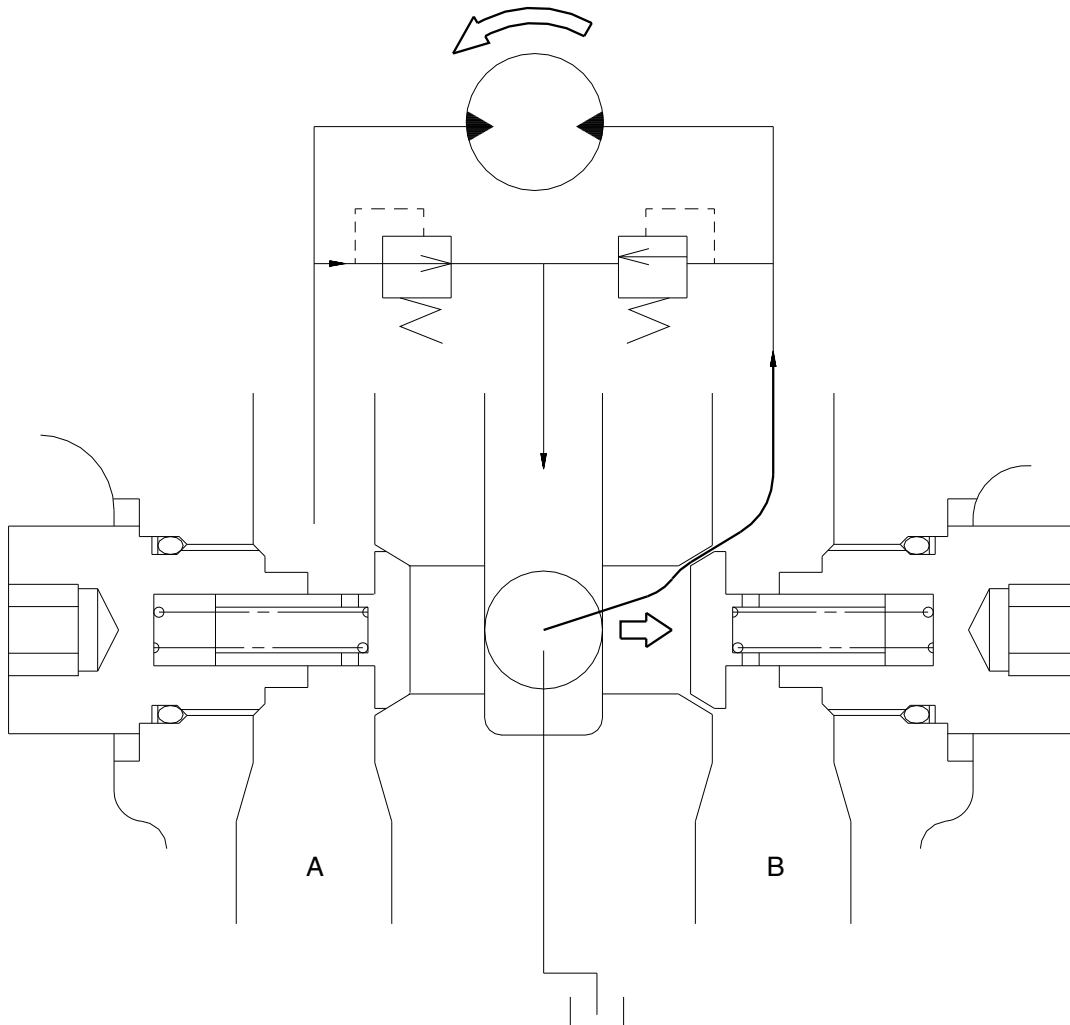

36072SM05

3) RELIEF VALVE

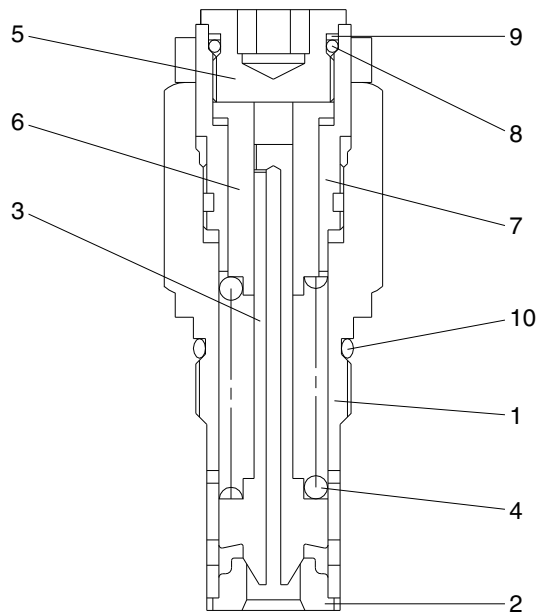

- 1 Body
- 2 Seat
- 3 Plunger
- 4 Spring
- 5 Adjusting screw
- 6 Piston
- 7 Sleeve
- 8 O-ring
- 9 Back up ring
- 10 O-ring

36072SM06

(1) Construction of relief valve

The valve casing contains two cartridge type relief valves that stop the regular and reverse rotations of the hydraulic motor. The relief valves relieve high pressure at start or at stop of swing motion and can control the relief pressure in two steps, high and low, in order to insure smooth operation.

(2) Function of relief valve

Figure illustrates how the pressure acting on the relief valve is related to its rising process. Here is given the function, referring to the figure following page.

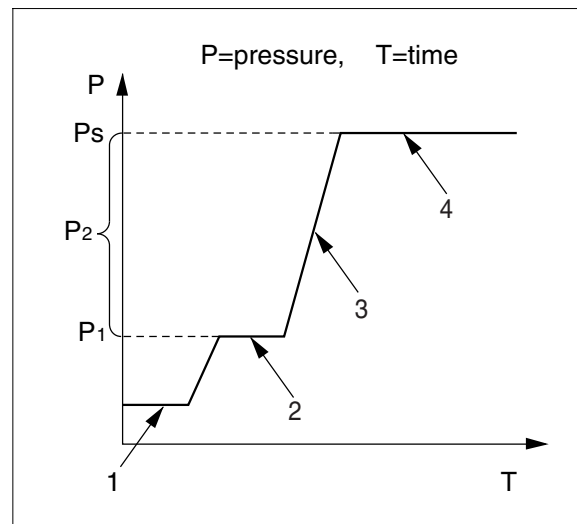

2-51(2) [360-7]

① Ports (P, R) at tank pressure.

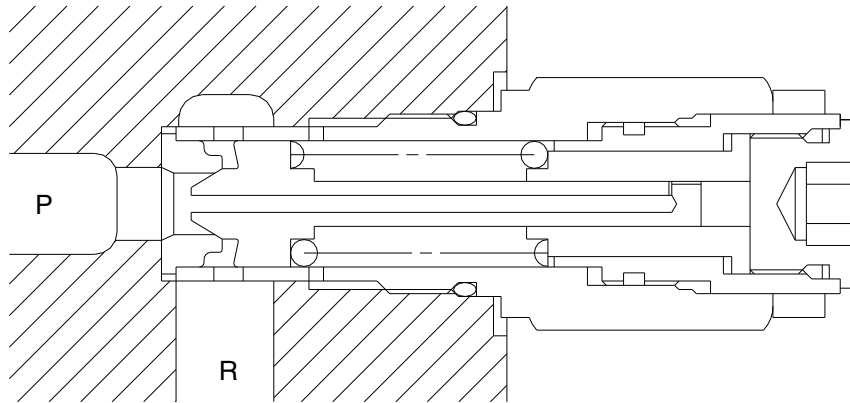

36072SM07

② When hydraulic oil pressure ($P \times A_1$) reaches the preset force (F_{SP}) of spring (4), the plunger (3) moves to the right as shown.

$$P_1 \times A_1 = F_{SP} + P_g \times A_2$$

$$P_1 = \frac{F_{SP} + P_g \times A_2}{A_1}$$

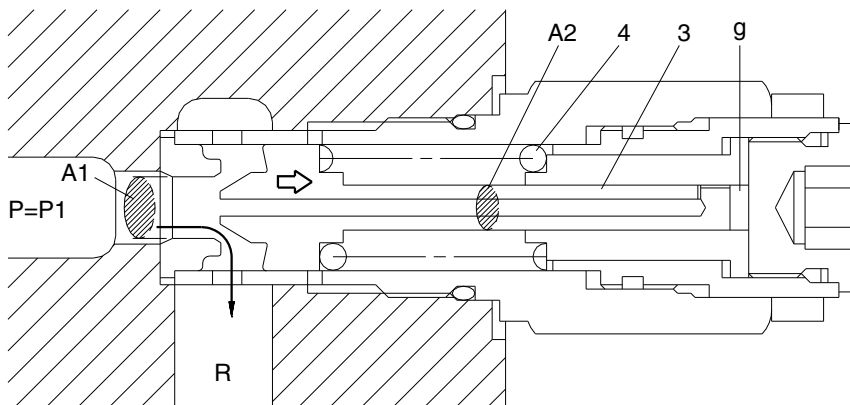

36072SM08

- ③ The oil flow chamber g via orifice m and n. When the pressure chamber g reaches the preset force (F_{sp}) of spring (4), the piston (6) moves left and stop the piston (6) hits the bottom of sleeve (7).

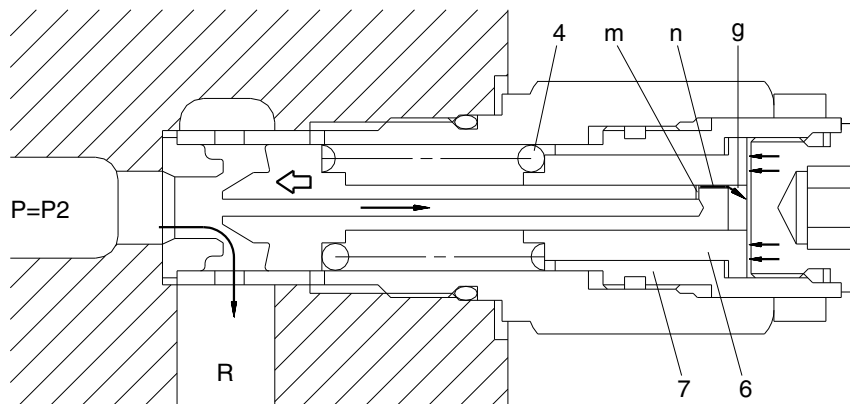

36072SM09

- ④ When piston (6) hits the end of sleeve (7), it stops moving to the left any further. As the result, the pressure in chamber (g) equals (P_s).

$$P_s \times A_1 = F_{sp} + P_s \times A_2$$

$$P_s = \frac{F_{sp}}{A_1 - A_2}$$

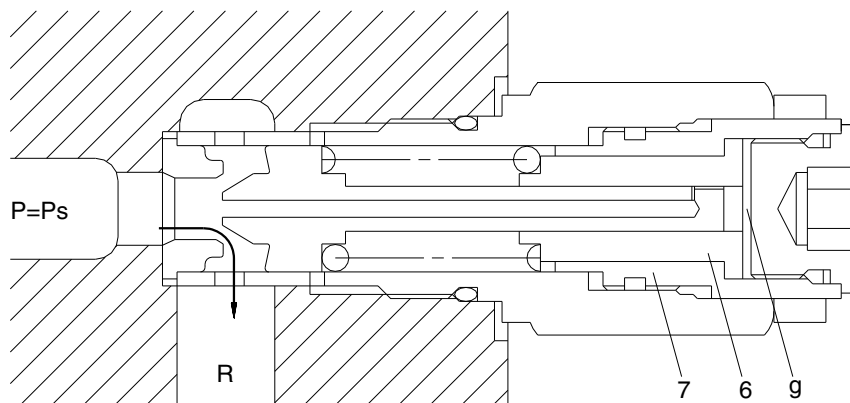

36072SM10

4) BRAKE SYSTEM

(1) Control valve swing brake system

This is the brake system to stop the swing motion of the excavator for during operation. In this system, the hydraulic circuit is throttled by the swing control valve, and the resistance created by this throttling works as a brake force to slow down the swing motion.

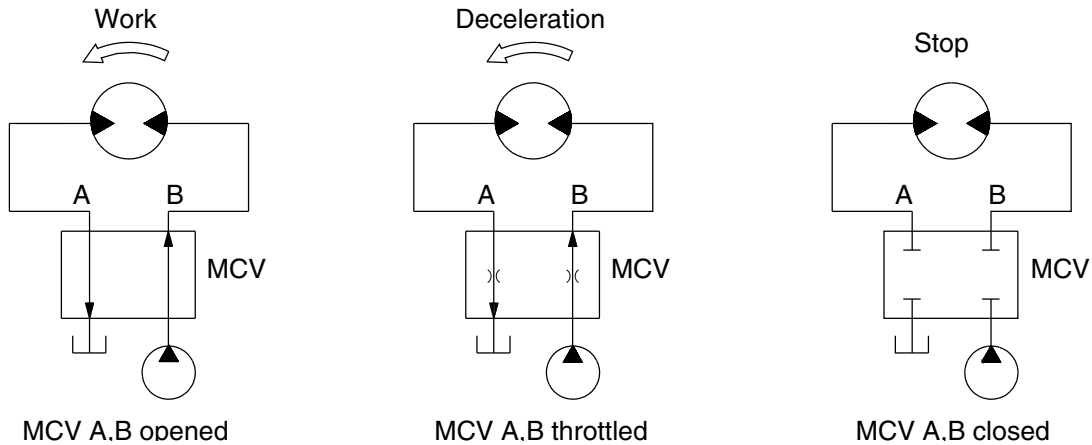

R130SM05

(2) Mechanical swing parking brake system

The mechanical swing parking brake system is installed to prevent the upper structure from swinging downhill because of its own weight when the excavator is parked on a slope since it completely eliminates the hydraulic drift of swing motion while the excavator is on a slope, work can be done more easily and safely.

① Brake assembly

Circumferential rotation of separate plate (13) is constrained by the groove located at casing (1). When housing is pressed down by brake spring (17) through friction plate (12), separate plate (13) and brake piston (16), friction force occurs there.

Cylinder block (6) is constrained by this friction force and brake acts, while brake releases when hydraulic force exceeds spring force.

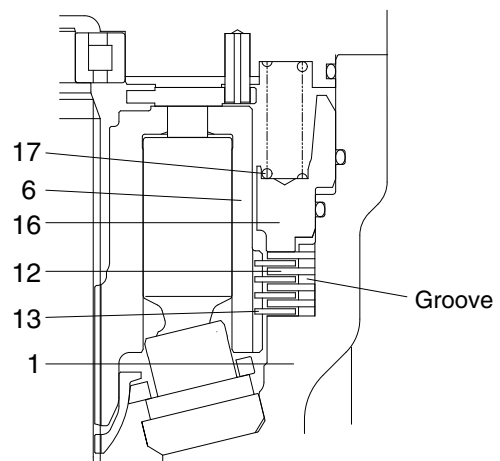

400A2SM11

1	Casing	13	Separate plate
6	Cylinder block	16	Brake piston
12	Friction plate	17	Brake spring

② **Operating principle**

a. When any of the swing, arm in, travel and boom up function is operated, the swing parking solenoid valve (5) is shifted to the swing position, so pilot pump charged oil (P3) goes to the chamber G through port PG.

This pressure is applied to move the brake piston (16) to the upward against the force of the brake spring (17). Thus, it releases the brake force.

b. Stop operation and a few second has been elapsed, the swing parking solenoid valve (5) is shifted to the swing parking position and swing brake works.

c. The swing brake works after RCV lever or pedal returns to the neutral position as below.

Fine swing switch	RCV single operation			
	Swing	Arm in	Boom up	Travel
OFF	5 sec	1 sec	N.A	N.A
ON	5 sec	1 sec	2 sec	3 sec

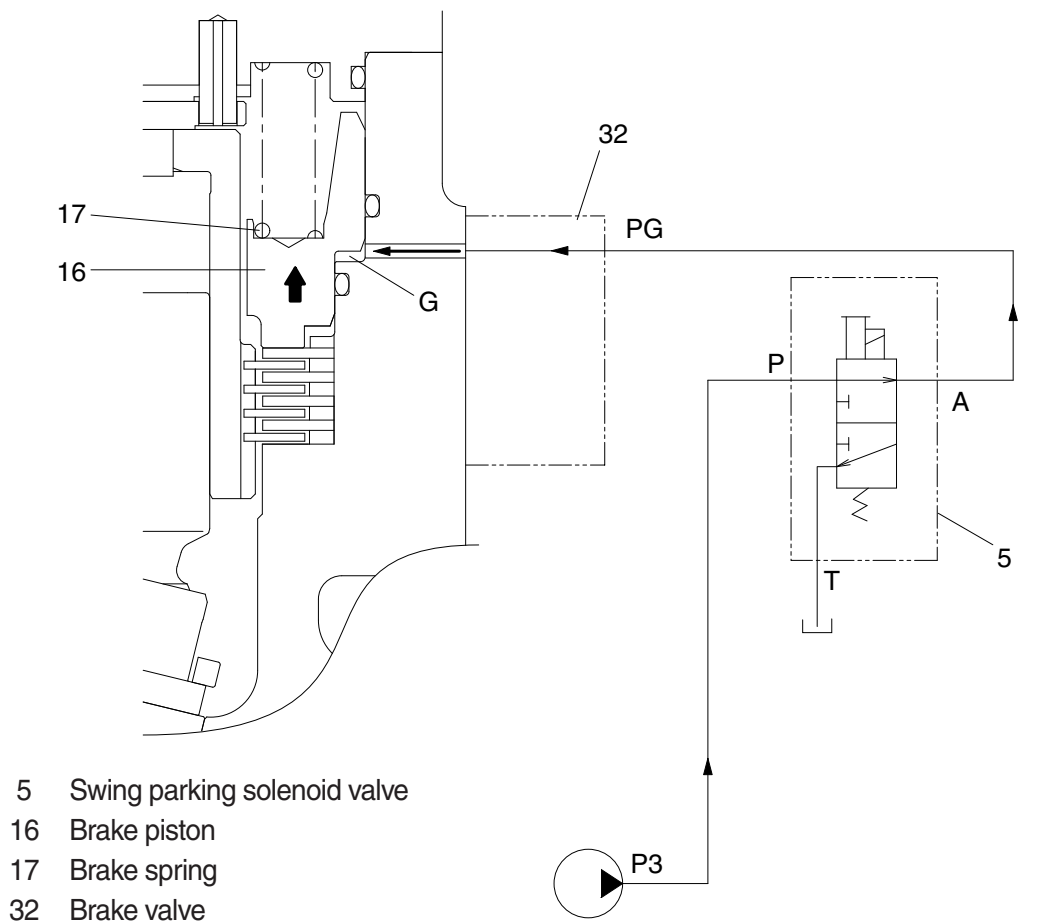

③ Manual override function

When the swing parking solenoid valve or related electric system is malfunction, the swing parking brake is not released even if the swing lever is operated.

To release the swing parking brake, the manual override function is needed.

※ Manual override solenoid valve

a. Use hand only to turn the control knob (do not use a tool).

b. Parking brake release

Turn the control knob to counterclockwise fully (about 2.5 mm)

c. Parking brake work

Turn the control knob to clockwise fully.

※ Be careful not damage the control knob by using a tool or tightening forcibly.

It can cause malfunction of the solenoid valve.

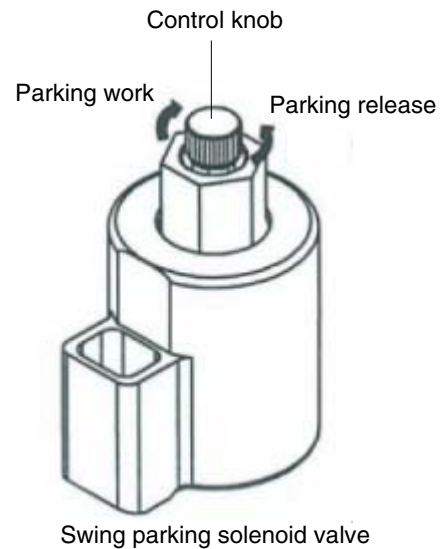

160A2SM11

GROUP 4 TRAVEL DEVICE (TYPE 1)

1. CONSTRUCTION

Travel device consists travel motor and reduction gear.

Travel motor include counterbalance valve, cross over relief valve.

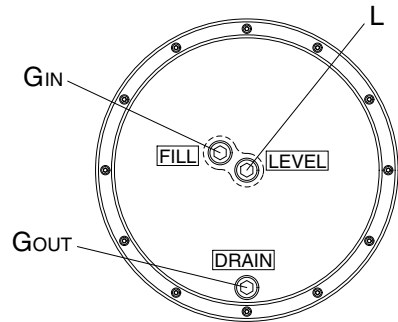
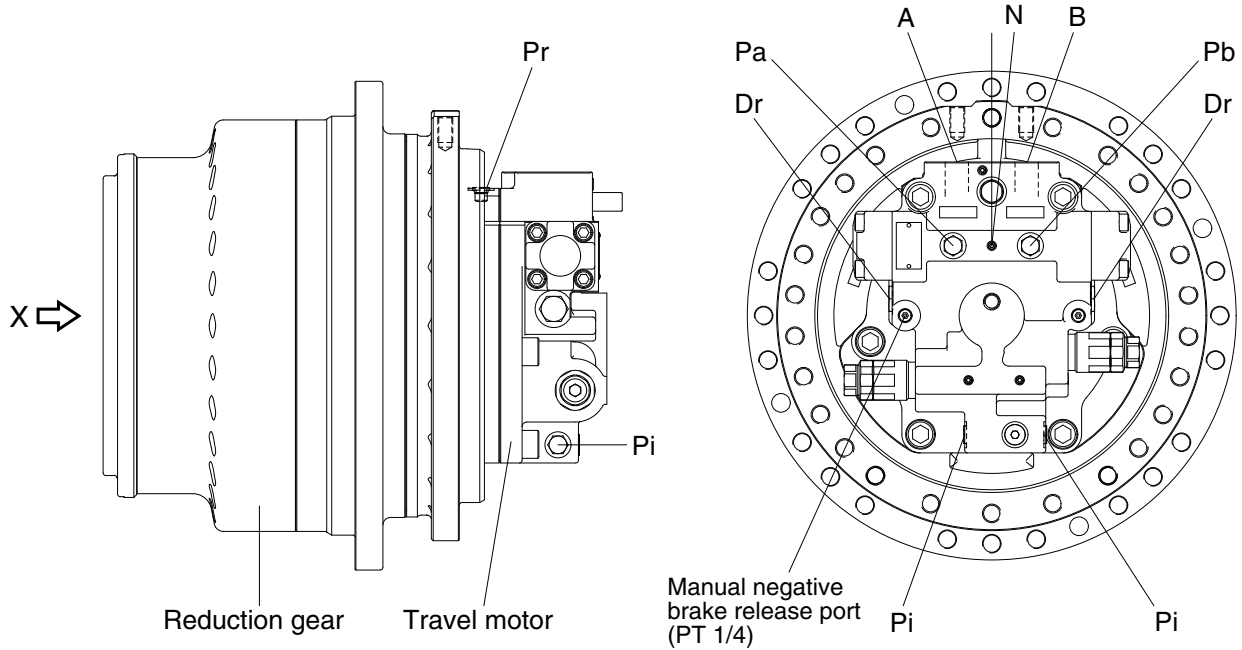

VIEW X

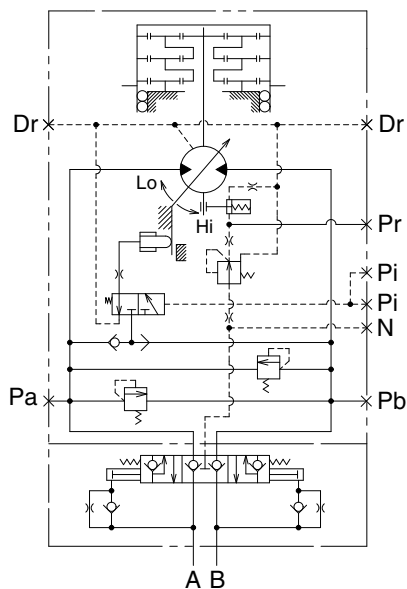

Hydraulic circuit

3809A2TM01

Port	Port name	Port size
A	Main port	SAE 6000 psi 1"
B	Main port	SAE 6000 psi 1"
Pi	Pilot port	PF 1/4
Dr	Drain port	PF 1/2
N	Negative brake release port	NPTF 1/16
Pa, Pb	Pressure gauge port	PF 1/4
Pr	Brake release pressure gauge port	PF 1/4
L	Level gauge	PF 1/2
GIN	Gear oil inlet port	PF 1/2
GOUT	Gear oil outlet port	PF 1/2

1) TRAVEL MOTOR (1/2)

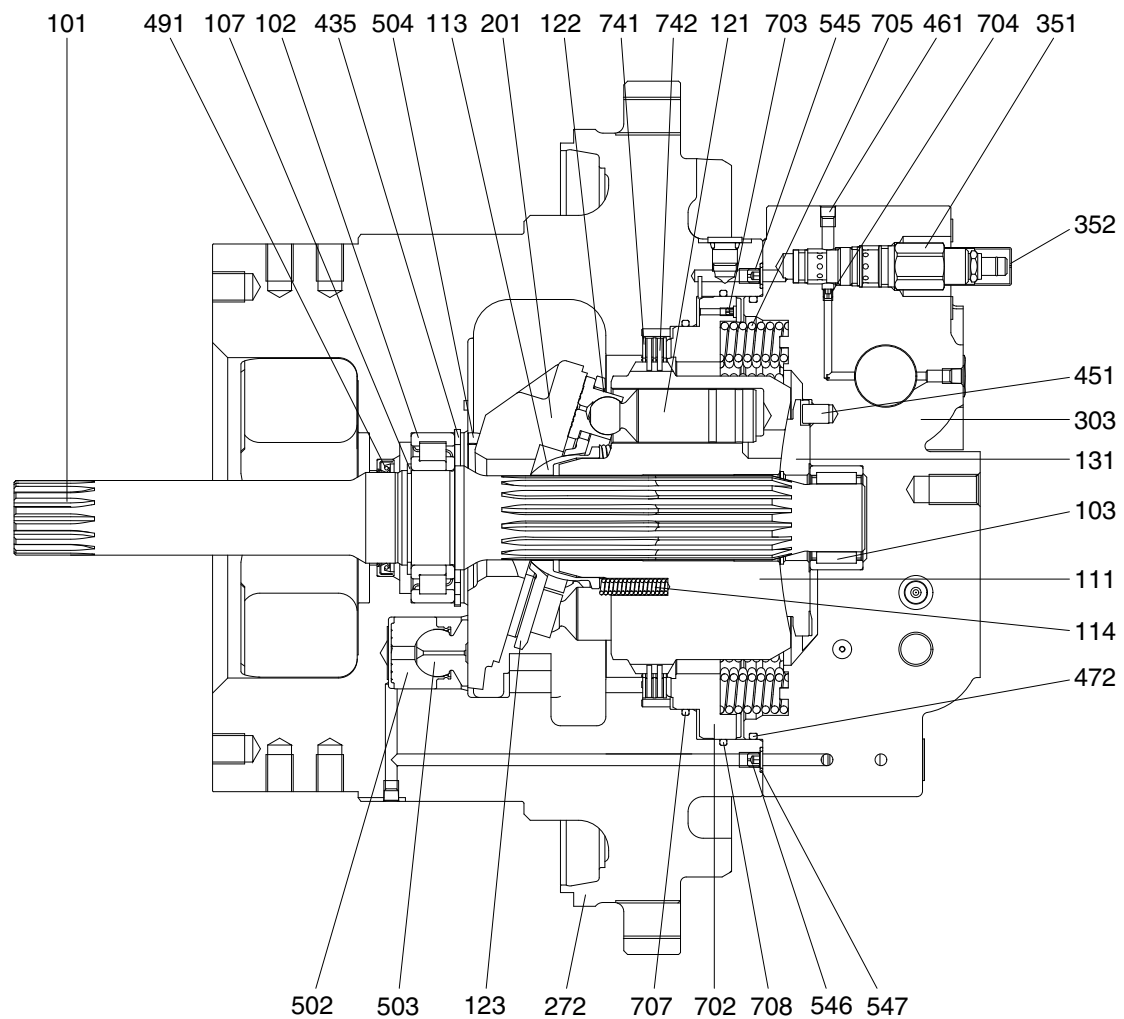

3809A2TM02

101 Drive shaft	272 Shaft casing	545 Orifice
102 Roller bearing	303 Valve casing	546 Orifice
103 Needle bearing	351 Reducing valve	547 O-ring
107 Snap ring	352 Cover	702 Brake piston
111 Cylinder block	435 Snap ring	703 Orifice
113 Spherical bushing	451 Pin	704 Orifice
114 Cylinder spring	461 Plug	705 Brake spring
121 Piston	472 O-ring	707 O-ring
122 Shoe	491 Oil seal	708 O-ring
123 Set plate	502 Piston	741 Separation plate
131 Valve plate	503 Shoe	742 Friction plate
201 Swash plate	504 Pivot ball	

TRAVEL MOTOR (2/2)

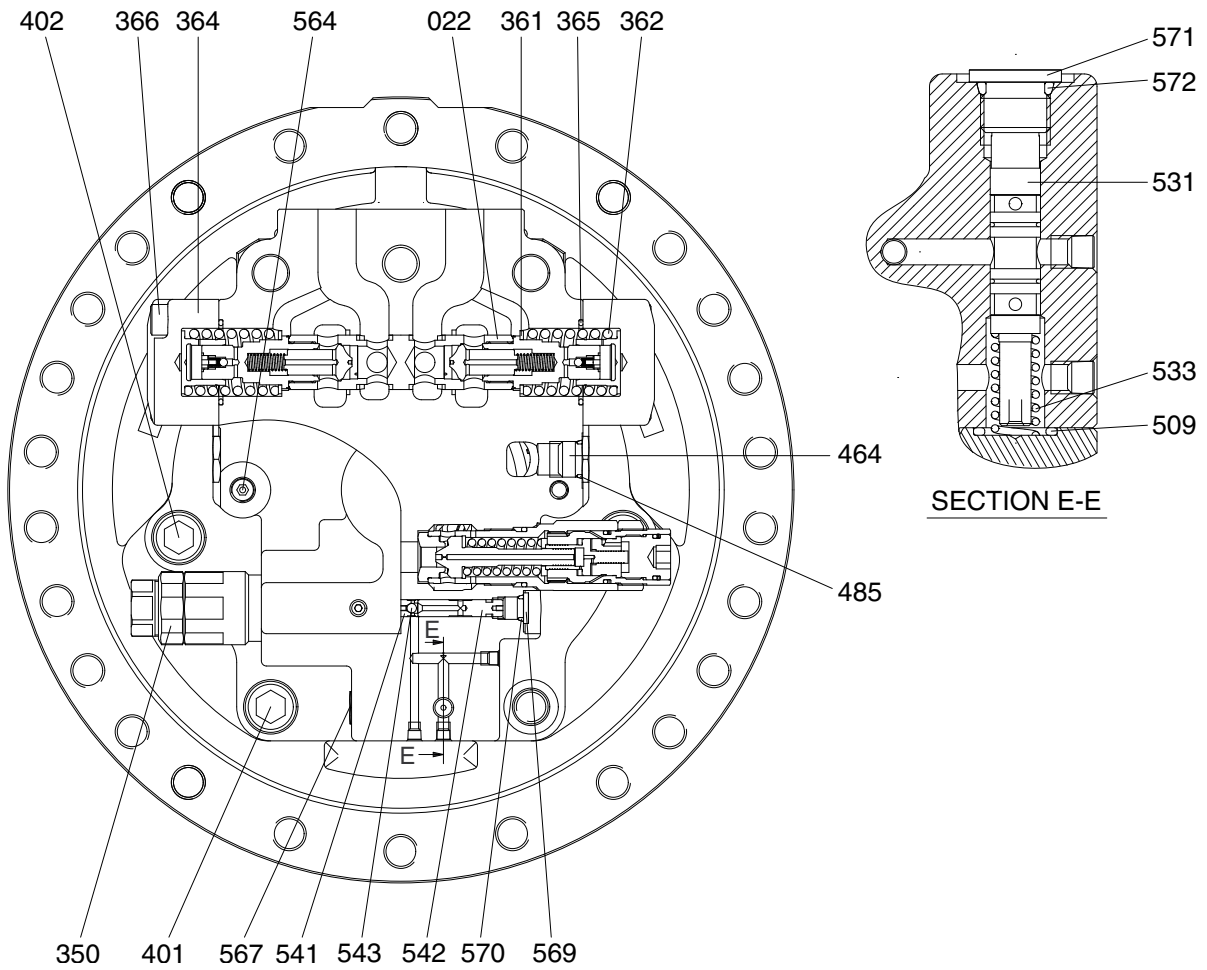

022 Counterbalance spool	402 Hex socket bolt	543 Steel ball
350 Relief valve	464 VP plug	564 Plug
361 Washer	485 O-ring	567 VP plug
362 Counterbalance spring	509 O-ring	569 RO plug
364 Counterbalance cover	531 Tilting spool	570 O-ring
365 O-ring	533 Tilting spring	571 RO plug
366 Hex socket bolt	541 Seat	572 O-ring
401 Hex socket bolt	542 Stopper	

3607A2TM03

2) REDUCTION GEAR

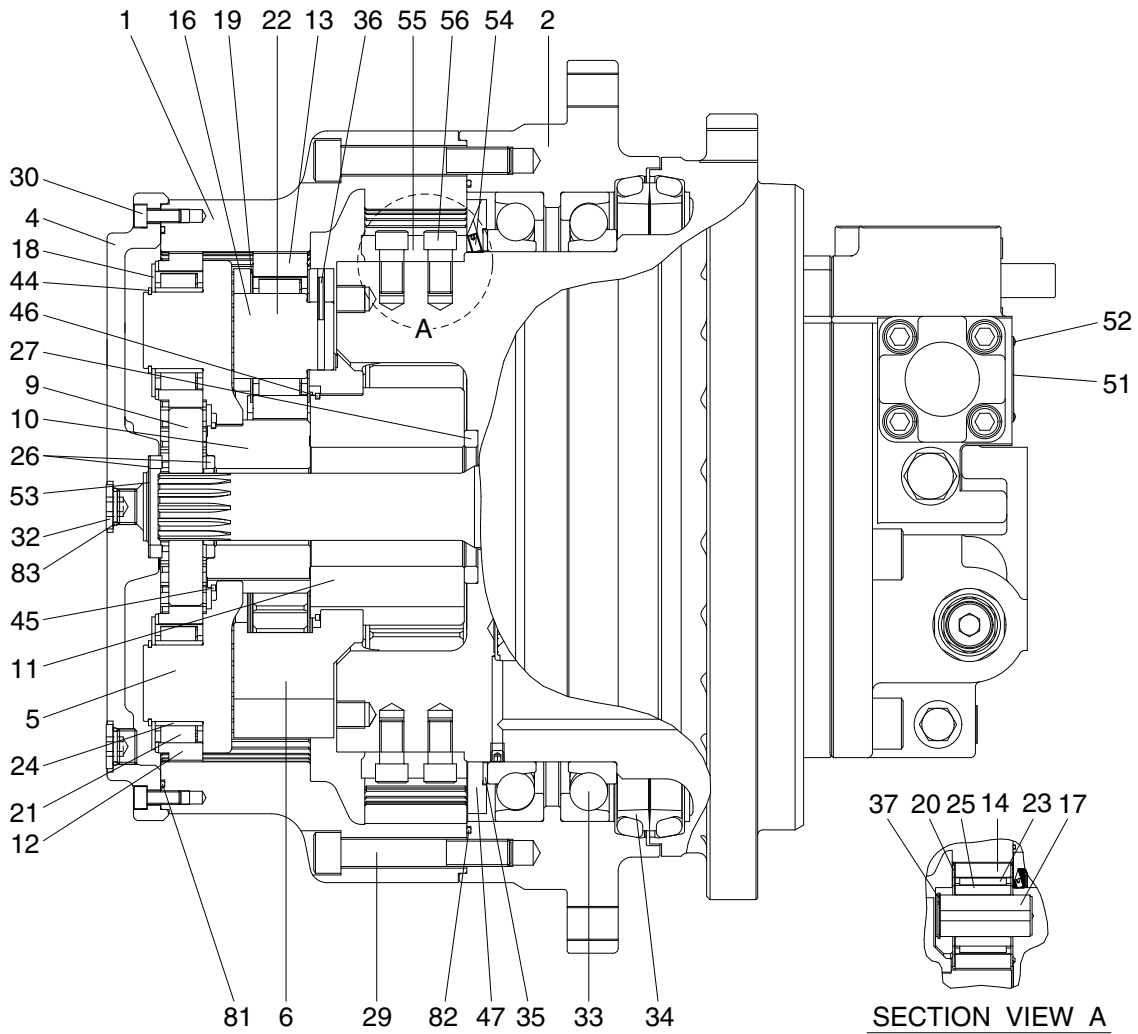

1	Ring gear	20	Side plate	37	Snap ring
2	Housing	21	Needle cage	44	Snap ring
4	Side cover	22	Needle cage	45	Clip
5	Carrier 1	23	Needle cage	46	W clip
6	Carrier 2	24	Inner ring	47	Nutring
9	Sun gear 1	25	Floating bushing	51	Name plate
10	Sun gear 2	26	Thrust ring	52	Rivet
11	Sun gear 3	27	Thrust ring	53	Washer
12	Planetary gear 1	29	Socket bolt	54	Set screw
13	Planetary gear 2	30	Socket bolt	55	Nutring stopper
14	Planetary gear 3	32	RO plug	56	Hex socket bolt
16	Pin 2	33	Angular bearing	81	O-ring
17	Pin 3	34	Floating seal	82	O-ring
18	Side plate	35	Shim	83	O-ring
19	Side plate	36	Spring pin		

2. FUNCTION

1) GENERATION OF TORQUE

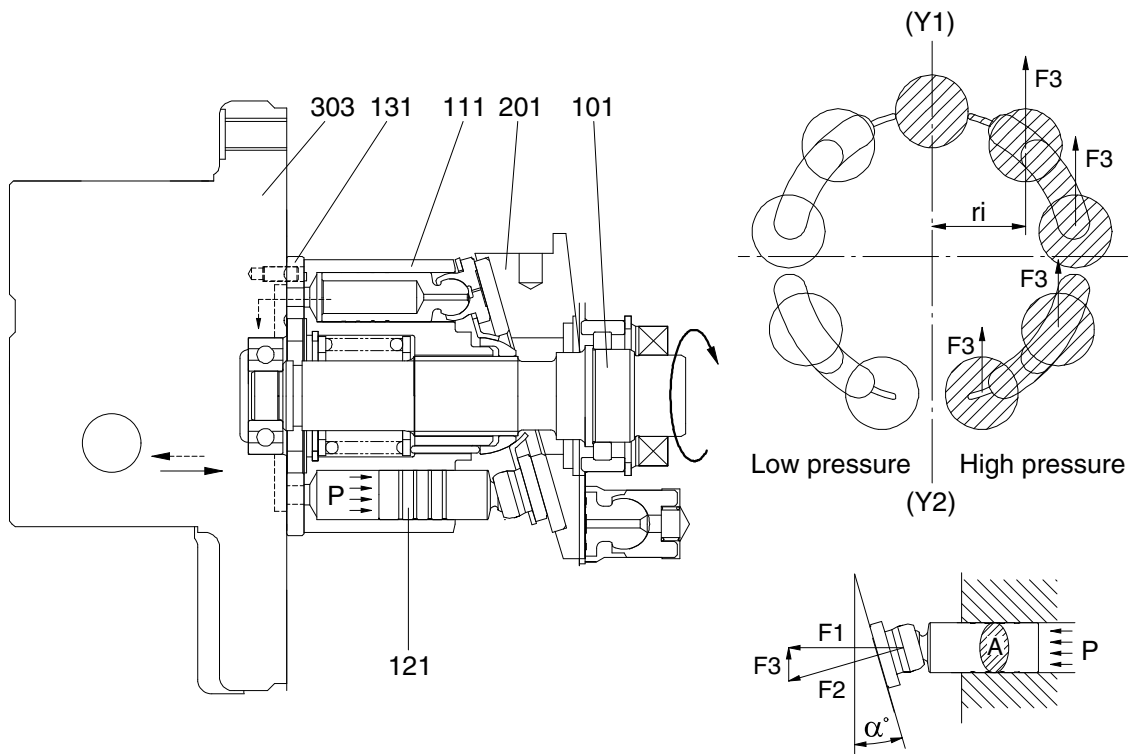

3607A2TRG02

The pressurized oil delivered from the hydraulic pump flows to valve casing (303) of the motor, passes through the brake valve mechanism, and is introduced into cylinder block (111) via valve plate (131). This oil constructively introduced only to one side of (Y1)- (Y2) connecting the upper and lower dead points of stroke of piston (121). The pressurized oil led to one side in cylinder block (111) pushes each piston (121) four or five and generates a forec [F (kgf) = P (kgf/cm²) × A (cm²)].

This force acts on swash plate (201), and is resolves into components (F2 and F3) because swash plate (201) is fixed at an angle (α) with the axis of drive shaft (101).

Radial component (F3) generates respective torques ($T = F3 \times ri$) for (Y1)- (Y2). This residual of torque [$T = S (F3 \times ri)$] rotates cylinder block (111) via piston (121).

Since the cylinder block (111) is spline coupled with drive shaft (101).

So the drive shaft (101) rotates and the torque is transmitted.

2) RELIEF VALVE

The relief valve mainly has the following two functions :

- (1) To keep the starting pressure of the hydraulic motor at a constant value and bypass to the return line excessive oil generated at the motor inlet depending upon the acceleration speed of the driven inertia.
- (2) To generate a brake pressure at the outlet during stopping of the driven inertia, and stop it forcedly.

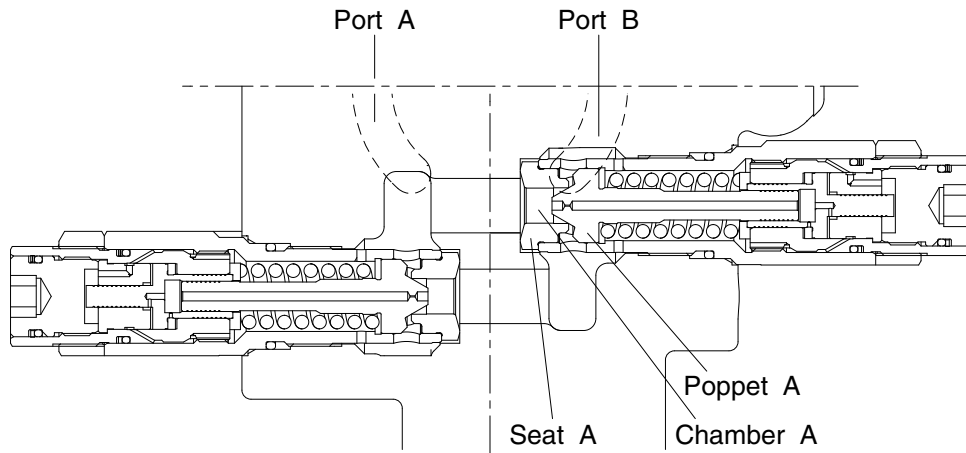

3607A2TM06

The chamber A is always connected to the port A of the motor.

When the pressure at port A increases and the force pushing poppet A is higher than the set pressure of the spring, then poppet A is pushed up from the contact surface of seat A, and oil flows from chamber A to port B.

3) NEGATIVE BRAKE

The negative brake is released applying to the brake piston (702) the pressure led through the built-in counterbalance spool sub-assembly (022).

With no pressure working, the brake force is always ensured.

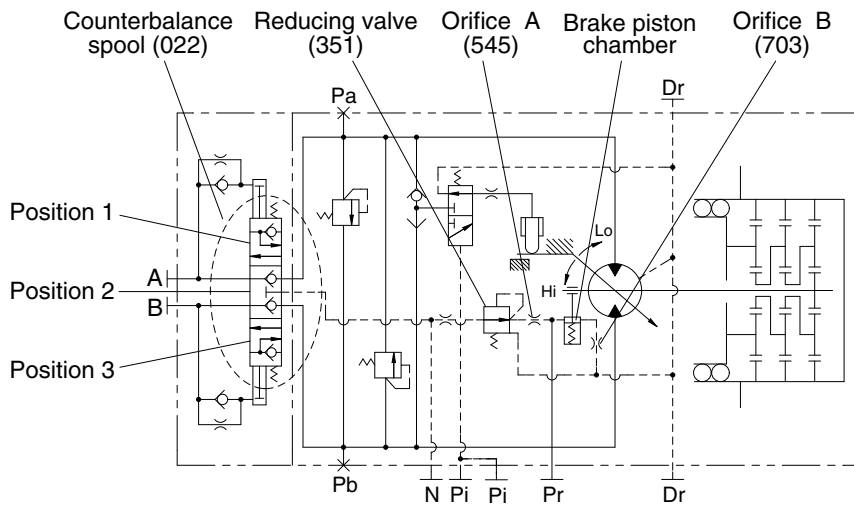
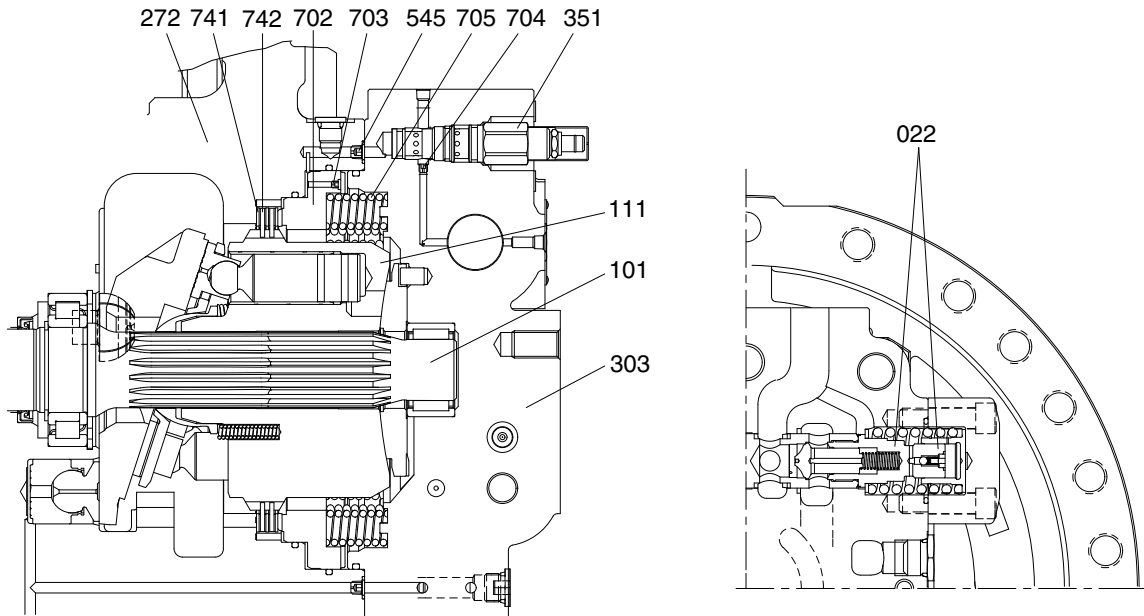

3607A2TM07

The brake force is the friction force generated on the surfaces of the friction plates (742) spline-coupled with the cylinder block (111), when their rotation is restricted by the shaft casing (272), separation plate (741), and brake piston (702).

Without pressure being applied to the brake piston, the brake piston is pushed by fourteen brake springs (705), and the friction plate and separation plate are held between the brake and shaft casing. This holding force functions as the friction force. This friction force restrains the shaft (101) spline-coupled with the cylinder block, and this function is the brake.

4) PRESSURE RELEASE VALVE (Flow control valve)

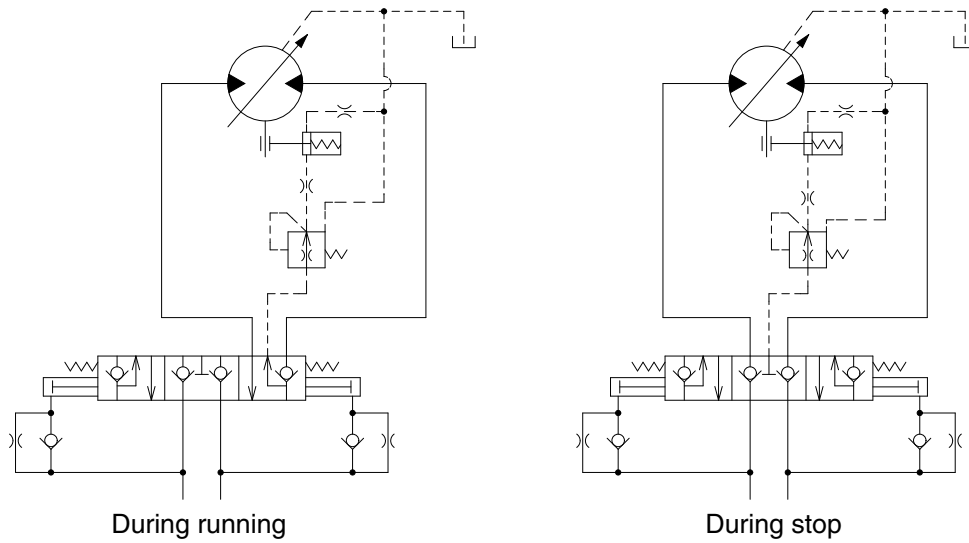

3607A2TM08A

This brake is of a backpressure-insensitive type. In other words, since the counterbalance spool used be overlapped at the neutral position, the pressure release valve prevents the circuit backpressure from working into the brake chamber when the machine stops traveling and works, and so the specified brake torque is available even on a slope.

During normal traveling, the pressure coming through the counterbalance valve is applied to the brake chamber to release the break, and is also applied to the pressure release valve section.

This pressure release valve is of a constant differential pressure type, and irrespective of the working pressure, the passing flow is constant and approximately 1 to 2 ℓ / min .

When the condition changes from traveling to stop, the counterbalance spool returns to its neutral position. The brake piston is pushed by the brake spring, and the oil in the brake chamber flow to the motor drain line via the pressure release valve. Then the brake torque is generated.

5) RELEASING METHOD OF NEGATIVE BRAKE

In releasing the negative brake without applying the brake releasing pressure, follow the procedures shown below.

Details of work	Tools
Remove two plugs (564) from the valve casing (303). (For their position, see the attached installation dimension) Tighten an M10 screw of 135 mm in length into a tapped hole of the brake piston (702). Then the condition having the brake release pressure is attained and the brake is released.	Socket wrench 6 mm 8 mm

Note : Even with the negative brake released, the hydraulic motor will not turn. When it is difficult to generate the working pressure due to failure of the pump or so, and the whole machine is to be pulled for transportation without removing the hydraulic motor, connect pressure measurement ports P_a and P_b with a short hose or something. Then the machine can be pulled slowly.

6) COUNTERBALANCE VALVE

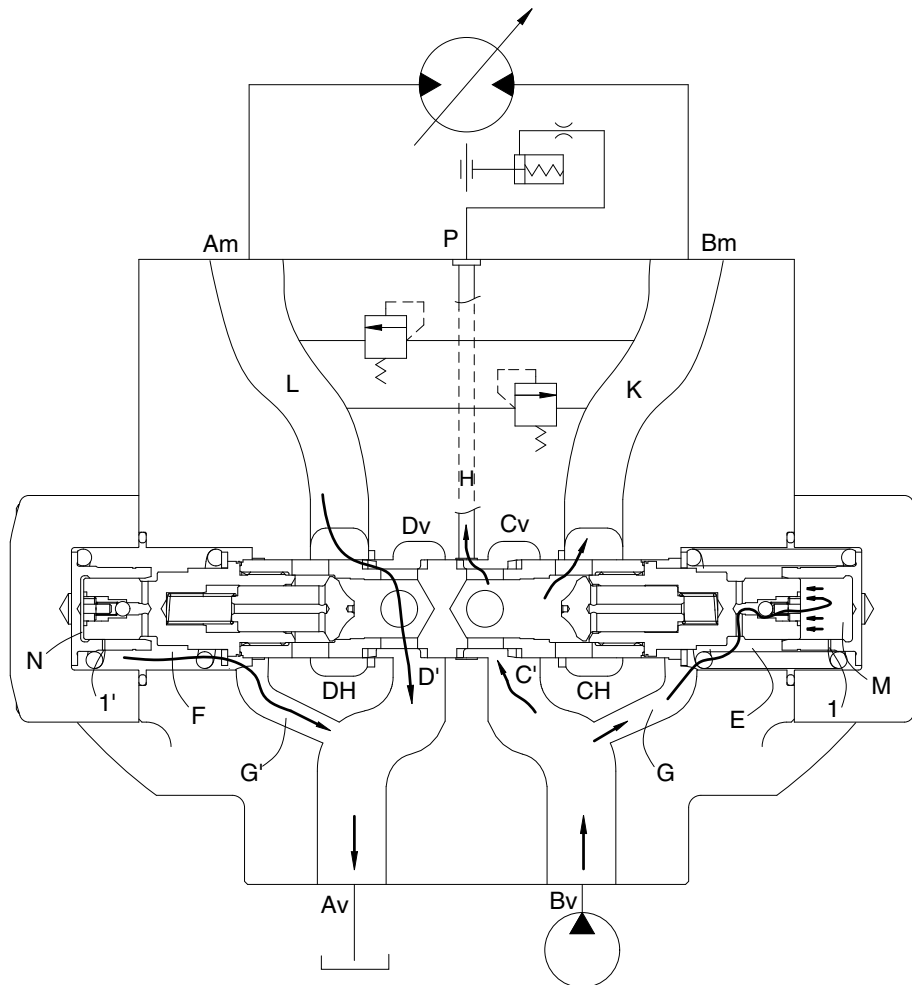

3607A2TRG03

Suppose port Bv is connected to the hydraulic pump and Port Av, to the tank. The oil supplied from the hydraulic pump passes through Bv, Cv and C' in sequence, pushes up the poppet of the check valve, passes through K to Port Bm, and is supplied to the hydraulic motor to turn it.

Therefore, the pump discharge oil pressure increases, and the pressure is led via passage G to spring room E and via the ball check valve to dumping room M. When the pressure in rooms E and M exceeds the value equivalent to the force of the spring which holds the spool at its neutral position, the spool begins to move left. Since the working oil in room N flows into room F via throttle 1' and that in room F is discharged via passage G' through port Av to the tank, the spool moves left to have passage L-DH-D'-Dv composed. In addition, passage Cv-H-P is also composed, and the pump discharge pressure in port Bv is led to port P.

Because of the throttle or clearance provided for the working oil flow from room N, this changeover motion of the spool is comparatively slow.

When the pump discharge pressure is higher, the spool movement is larger and the above opening area of the spool is larger.

When the pump discharge pressure falls, pressures in rooms E and M fall and the spool will move right due to the spring on the room F side.

Since working oil in room M flows to room E via throttle 1 and that in room E, to port Bv via passage G, the spool moves right.

When the pressure at port Bv falls down to the tank pressure, the pressure in room E also falls to the tank pressure and becomes equal to that in room F, and so the spool returns to its neutral position.

7) DISPLACEMENT CHANGEOVER SECTION

As a supporting mechanism for the swash plate (201) on which the shoes (122) slide, the pillar system is adopted to support the load with semi-cylindrical sliding bearings provided at both ends of the mechanism.

The capacity is changed by changing the tilting angle of this swash plate.

This is a mechanism that swash plate was pushed by tilting position, and the tilting angle of the swash plate is decided in two positions (large and small) by controlling the flows to and from these piston rooms with the displacement changeover valve section.

(1) External pilot pressure : $P_i = 0$ Large displacement

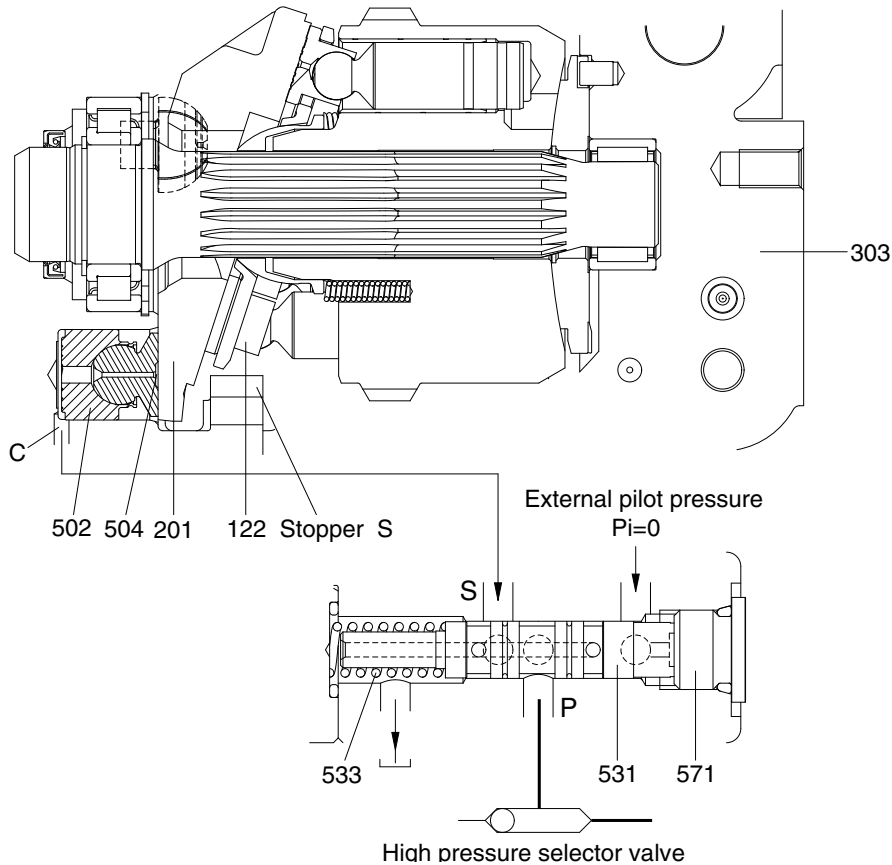

3607A2TM04

By means of the built-in high pressure selector mechanism in the valve casing (303), the high pressure oil working on the motor functions to port P of the displacement-changeover valve. This pressure becomes the servo pressure. Since the spool (531) assembled in the displacement changeover valve is pressed to plug (571) by thy spring (533), the high pressure oil at port P is enclosed.

(2) External pilot pressure : $P_i \geq 20 \text{ kgf/cm}^2$ ——— small displacement

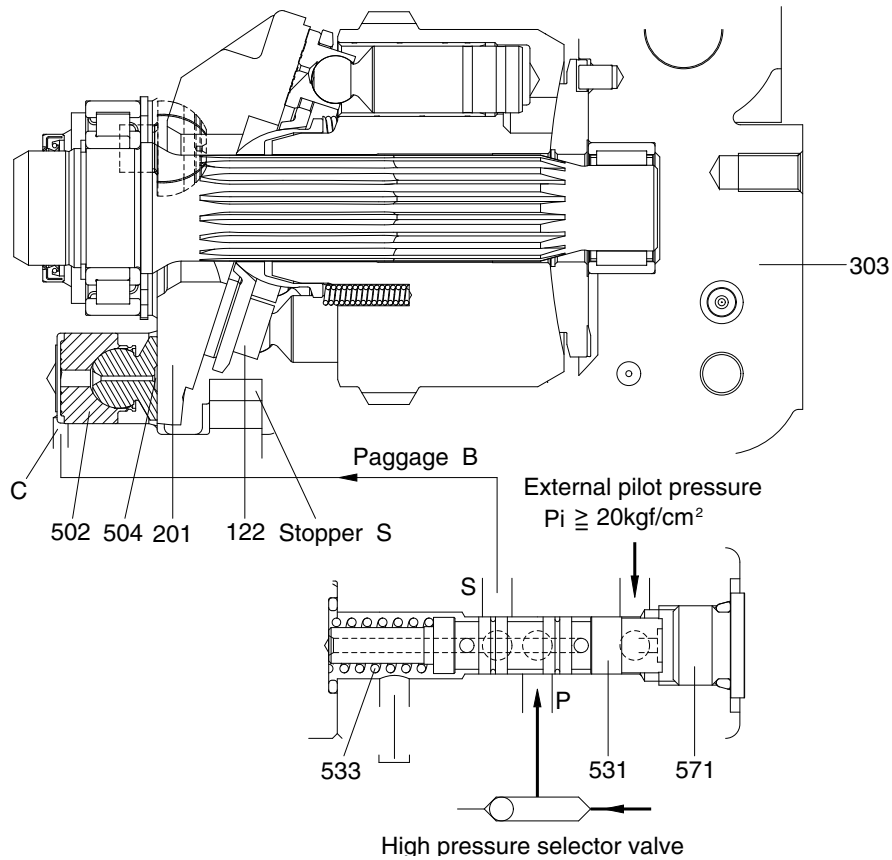

3607A2TM05

The force working on the spool (531) of the displacement-changeover valve becomes higher than that of the spring (533), and the spool moves left. The high pressure oil flows from port P of the displacement-changeover valve through port S and passage B to room C where it works. The displacement changeover piston (502) is pushed light by the high pressure oil and the swash plate moves in the arrowed direction. The swash plate moves until it touched stopper S, and then is fixed there.

8) REDUCTION GEAR

The reduction gear is composed of a three-stage planetary gear mechanism shown in the following figure. Since the sun gear is designed to have a floating mechanism, errors of the gears and carrier pin hole pitches will not affect the gears' lives heavily.

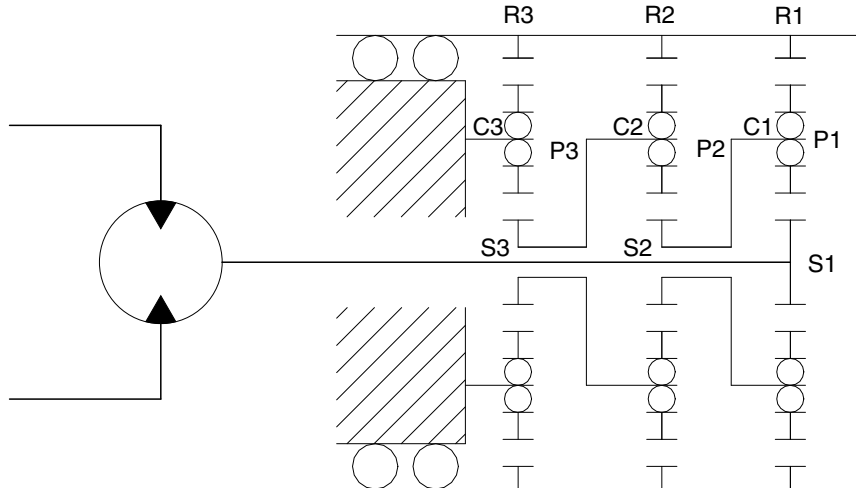

3607A2TRG04

The input rotation of the hydraulic motor is transmitted to No. 1 sun gear (S1) and this drives No. 1 planetary gears (P1). This No. 1 planetary gears (P1) drive No.1 ring gear (R1) with the same force as the meshing tangential force with No. 1 sun gear (S1), and also No. 1 carrier (C1) with the same force as the meshing reaction force. In other words, No. 1 planetary gears (P1) revolve rotating. This rotation of No. 1 carrier (C1) becomes the output of the 1st stage, and is transmitted directly to No. 2 sun gear (S2).

(No. 1 carrier is spline-coupled with No. 2 sun gear.) Similarly the revolution of No. 2 planetary gear (P2) are transmitted via No.2 carrier (C2) to No. 3 sun gear (S3). Since No. 3 carrier (C3) supporting No. 3 planetary gears (P3) are fixed, No. 3 planetary gears (P3) do not revolve, but rotates to drive No. 3 ring gear (R3).

Therefore, the rotating case is driven by the overall driving torque of No1, 2 and 3 ring gears.

This reduction ratio is expressed as shown below:

$$i = \frac{(Z_{S1} + Z_{R1}) (Z_{S2} + Z_{R2}) (Z_{S3} + Z_{R3})}{Z_{S1} \cdot Z_{S2} \cdot Z_{S3}} - 1$$

where Z : Number of teeth of each gear

The direction of rotation is reverse to that of the input shaft.

TRAVEL DEVICE (TYPE 2, MACHINE SERIAL NO. : #0190-)

1. CONSTRUCTION

Travel device consists travel motor and gear box.

Travel motor includes brake valve, parking brake and high/low speed changeover mechanism.

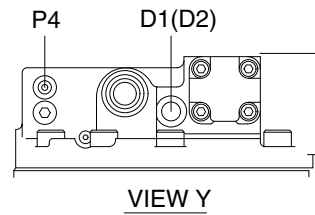
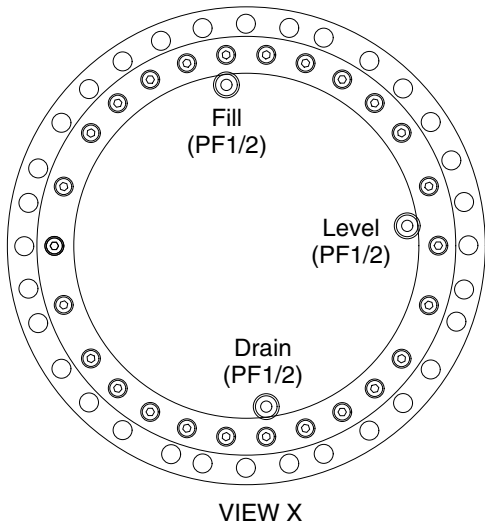
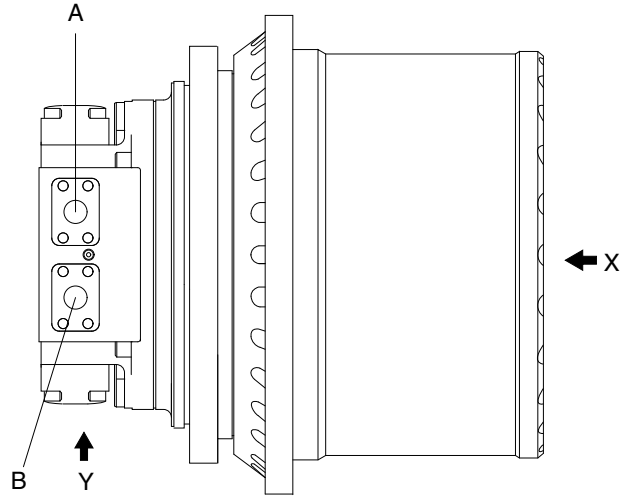
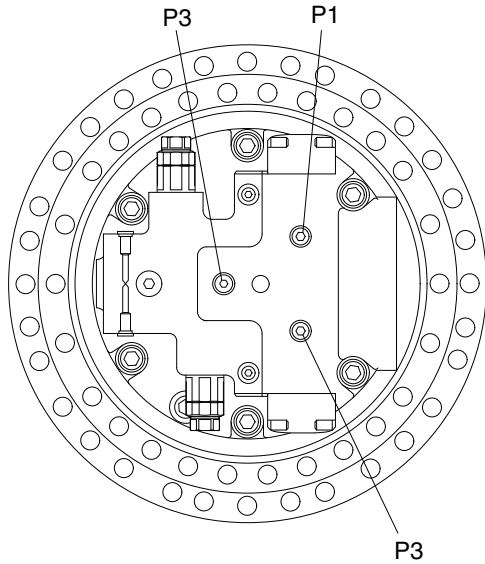

VIEW X

VIEW Y

Port	Port name	Port size
A, B	Main port	SAE 6000 psi 1"
P1, P2	Pressure gauge port	PF 1/4-15
P3	Brake release port	PF 1/4-15
P4	Speed shift port	PF 1/4-15
D1, D2	Drain port	PF 1/2-19

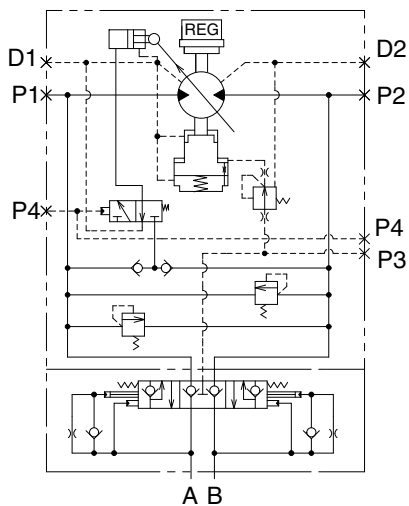

Hydraulic circuit

320A2TM01E

2. STRUCTURE

1) TRAVEL MOTOR (1/2)

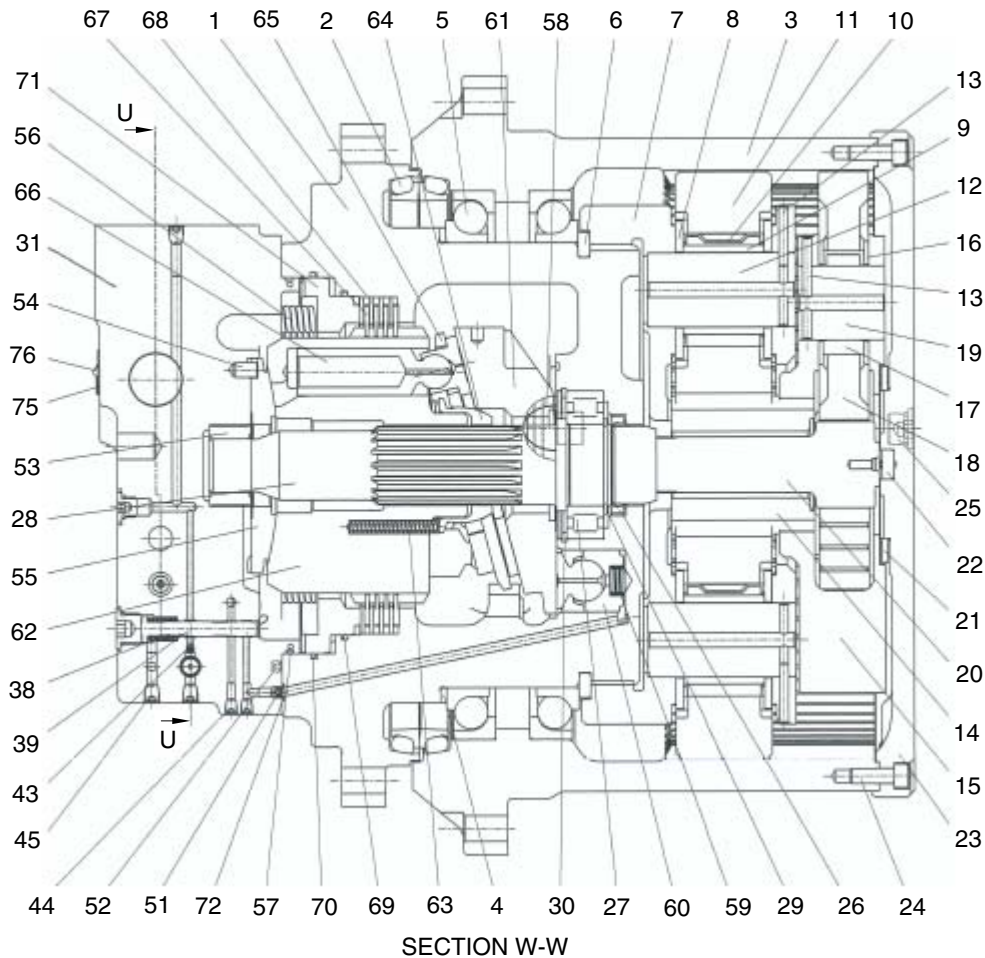

320A2TM02

1	Casing	21	Thrust plate	55	Timing plate
2	Floating seal	22	Thrust washer	56	Spring
3	Hub	23	Cover	57	O-ring
4	Distance piece	24	Socket bolt	58	Pivot
5	Ball bearing	25	Plug	59	2 speed piston spring
6	Shim plate	26	Shaft seal	60	1 speed spring
7	Carrier no.2	27	Roller bearing	61	Swash plate
8	Thrust washer	28	Drive shaft	62	Cylinder block
9	Floating bushing	29	Snap ring	63	Cylinder block spring
10	Needle roller bearing	30	Snap ring	64	Spherical bus
11	Planetary gear	31	Valve casing	65	Retainer plate
12	Shaft	38	2 speed spring	66	Piston
13	Spring pin	39	Spool	67	Friction plate
14	Sun gear	43	Orifice	68	Separation plate
15	Carrier no.1	44	Plug	69	O-ring
16	Thrust washer	45	Plug	70	O-ring
17	Needle bearing	51	Orifice	71	Brake piston
18	Planetary gear	52	Orifice	72	O-ring
19	Shaft	53	Needle bearing	75	Name plate
20	Drive gear	54	Parallel pin	76	Screw

TRAVEL MOTOR (2/2)

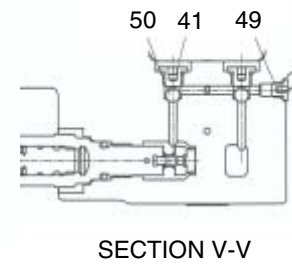
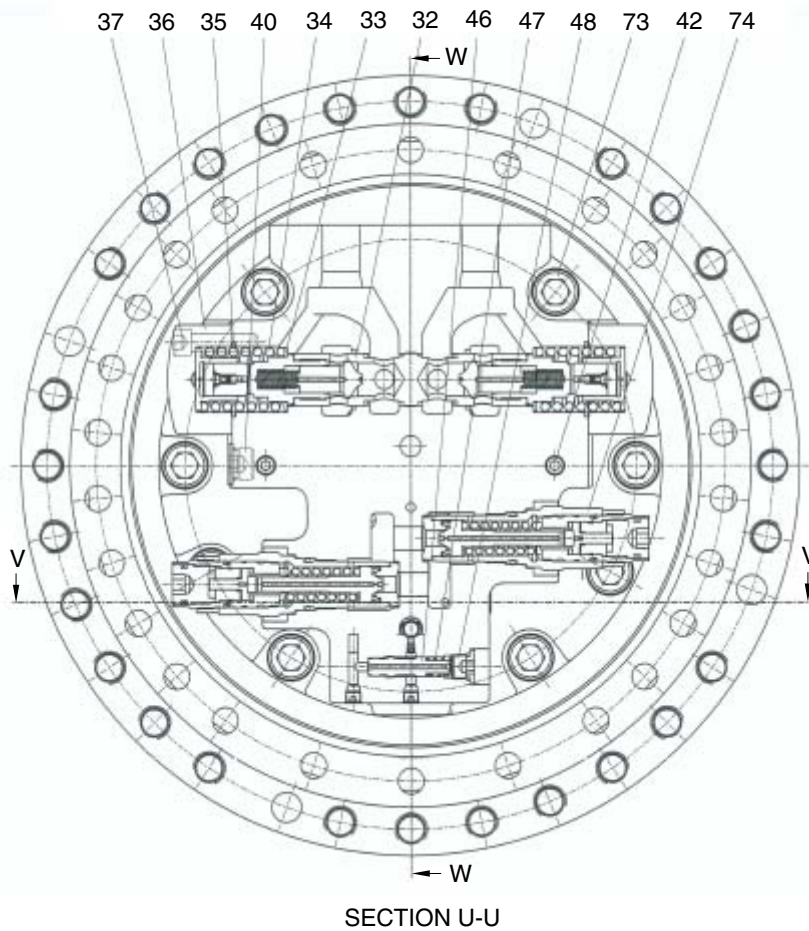

32	Counterbalance spool	40	Plug	49	Plug
33	Counterbalance washer	41	Plug	50	Steel ball
34	Counterbalance main spring	42	Plug	73	Socket bolt
35	O-ring	46	Reducing valve	74	Relief valve
36	Cover	47	Reducing spring		
37	Socket bolt	48	Plug		

320A2TM03

3. OPERATION

1) HYDRAULIC MOTOR

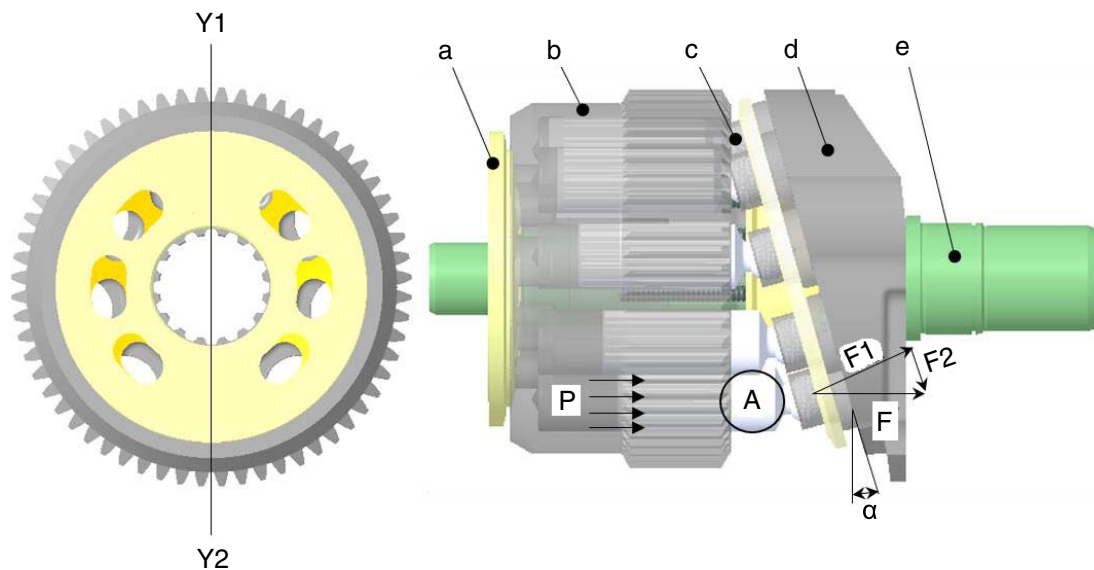

300L2TM04

- (1) The fluid supplied from the main control valve flows into the cylinder block (b) through the valve plate (a) of the hydraulic motor. This time, half of the fluid will flow in and half will flow out based on Y1-Y2 connecting the top dead center (TDC) and the bottom dead center (BDC) of the piston (c) stroke.
- (2) Then, the fluid will act on the piston (c) and push the swash plate (d) with the force of P (supply pressure) \times A (piston area) to generate reaction force F .
- (3) F is divided into the forces $F1$ and $F2$ by the swash plate (d) tilted at an angle α and the rotational force is generated by $F2$.
- (4) The rotational force is applied with the resultant force generated by each piston in the direction in which the fluid flows to rotate the cylinder block (b) and the rotational force is transmitted to the drive shaft (e) connected with a spline.

2) COUNTERBALANCE VALVE

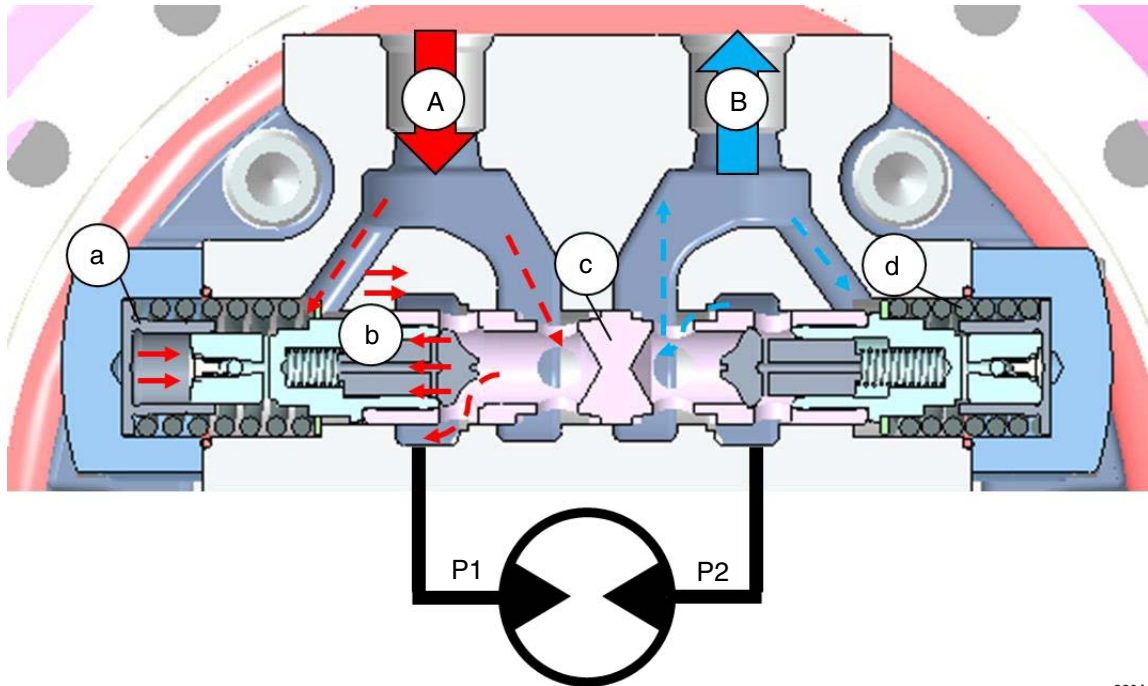

320A2TM06

- (1) If a fluid is supplied to port A through the main control valve, the check valve (b) is pushed to the left to feed the inlet flow path (P1) and rotate the hydraulic motor.
- (2) At the same time, the fluid passing through the orifice (a) pushes the counterbalance spool (c) in the right direction. If the pushing force is greater than the opposite spring (d) force, the counterbalance spool (c) will move.
- (3) The fluid discharged by the rotation of the hydraulic motor will pass through the outlet flow path (P2) and the notch of the counterbalance spool (c) and emitted to the port B. This time, a decrease in the pressure of the fluid supplied to port A results in a decrease in the force pushing the counterbalance spool (c) will return to the neutral direction by the spring (d) force on the opposite side.
- (4) Repeat this process to control the fluid emitting from the hydraulic motor and avoid overruns.

3) 2-SPEED SHIFT

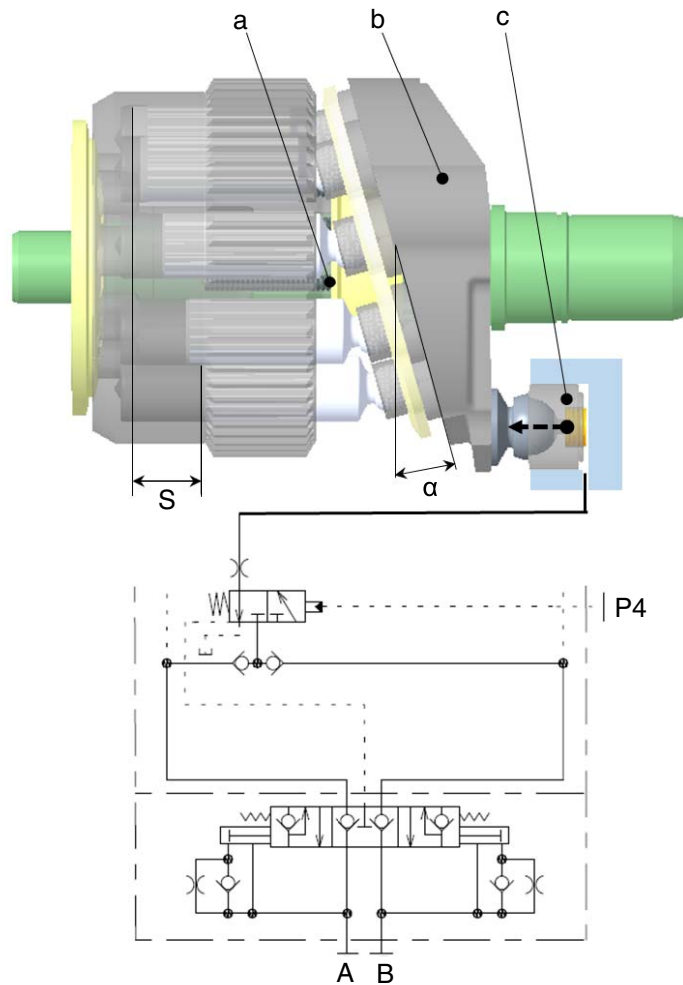

320A2TM07

- (1) If the pilot pressure (P4) is supplied at the specified pressure to shift the rotating hydraulic motor to a higher gear, the shifting piston (c) pushed the swash plate (b), resulting a reduction of the swivel angle α . The smaller the swivel angle α , the shorter the stroke length s of the piston (a) and the smaller the stroke volume.
- (2) This results in a faster rotational speed and a lower torque of the hydraulic motor.
 If the pilot pressure (P4) is less than the specified pressure, the force pushing the swash plate (b) of the shifting piston (c) will weaken and return to the original state. As the swivel angle α increase, the stroke length of the piston (a) becomes longer, which results in a slower rotational speed and higher torque of the hydraulic motor.

4) PARKING BRAKE

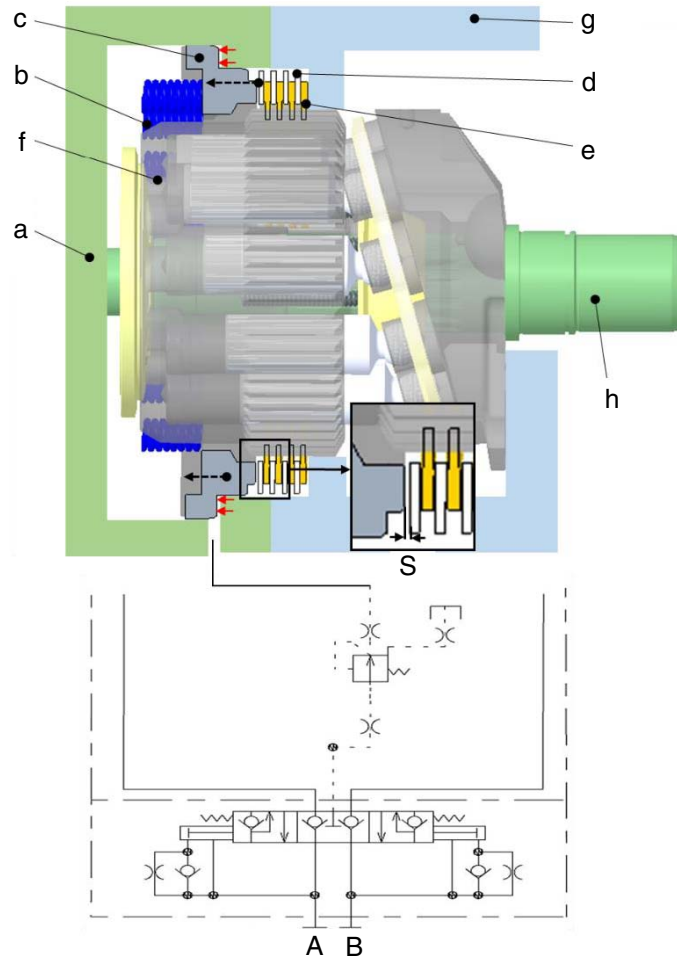

320A2TM08

- (1) If no fluid is supplied to the hydraulic motor, the parking brake will engage automatically. The parking brake pressed the separation plate (d) fixed to the motor casing (g) and the friction plate (e) grooved to the cylinder block (f) into the brake piston (c) by the force of the brake spring (b) assembled between the valve casing (a) and the brake piston (c). This prevents the rotation of the cylinder block (f) and the drive shaft (h) connected with the spline.
- (2) If a fluid is supplied to the hydraulic motor, the fluid passing through the counterbalance spool will pass through the flow path of the motor casing (g) and force will be applied to the brake piston (c) in the opposite direction to the brake spring (b). If a fluid is supplied exceeding the specified level, the brake spring (b) is compressed as far as the displacement s . This will release the compression between the friction plate (e) and the separation plate (d) and allow the drive shaft (h) to rotate.

5) RELIEF VALVE

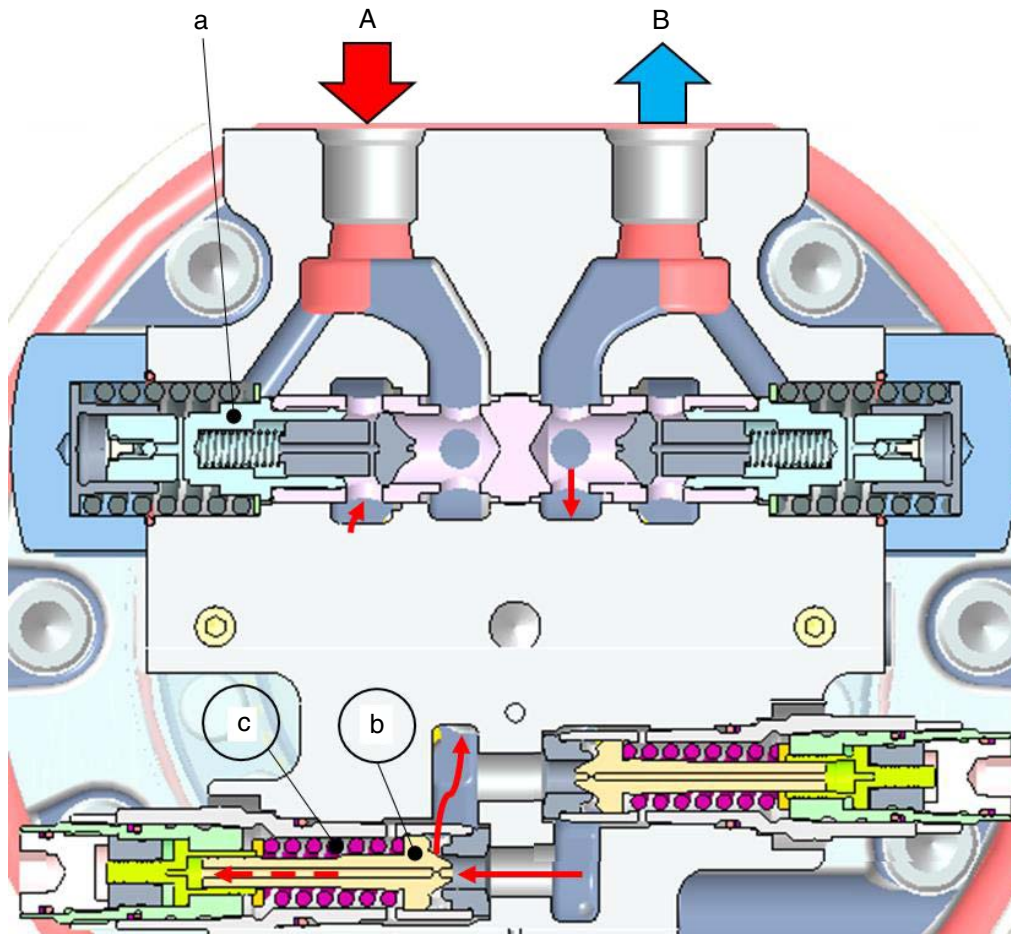

320A2TM09

- (1) The counterbalance valve (a) slides to the neutral position and blocks the flow path between the inlet (A) and outlet (B) when the motor stops while rotating.
- (2) The internal pressure on the outlet (B) increases due to the motor inertia. The force what applied on the poppet (b) opens the poppet (b) when the force applied on the poppet is greater than the spring (c) setting force.
- (3) At this time, some of fluid flows to the drain and the fluid slows toward the inlet (A) to prevent cavitation.
- (4) The spring (c) on the poppet (b) returns to the original position and block the flow path due to decreased internal pressure on the outlet (B) by drained fluid.

GROUP 5 RCV LEVER

1. STRUCTURE

The casing has the oil inlet port P (primary pressure) and the oil outlet port T (tank). In addition the secondary pressure is taken out through ports 1, 2, 3 and 4 provided at the bottom face.

※ Refer to the parts manual for the types of the RCV lever.

1) TYPE M1, M10

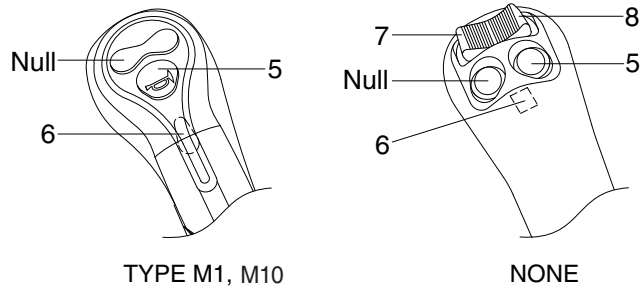
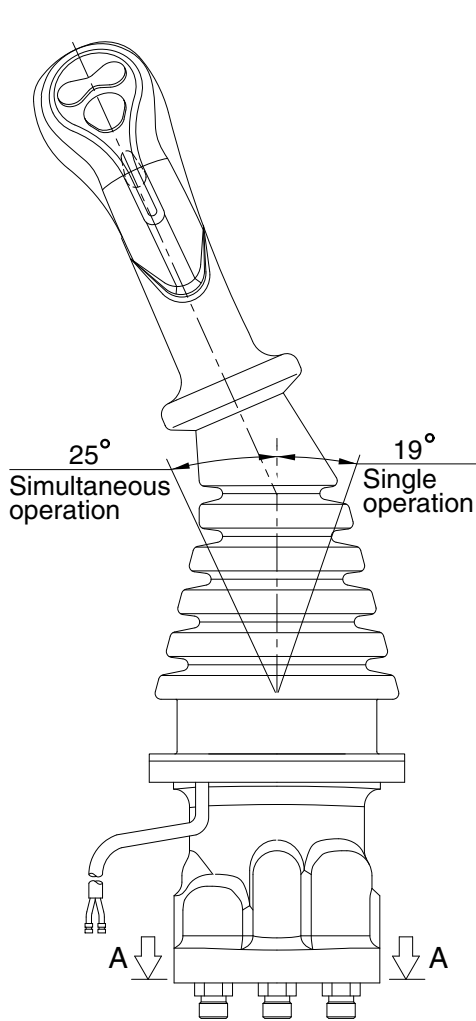

Switches

Type	No.	LH	RH
M1, M10	5	One touch decel	Horn
	6	Power boost	Breaker
None	5	One touch decel	Horn
	6	Power boost	Null
	7	CCW rotation	Close
	8	CW rotation	Open

※ Number 7 and 8 : Option attachment

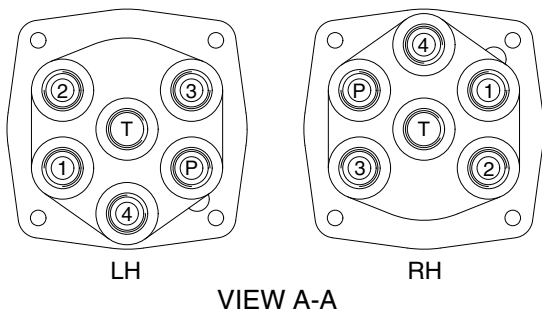
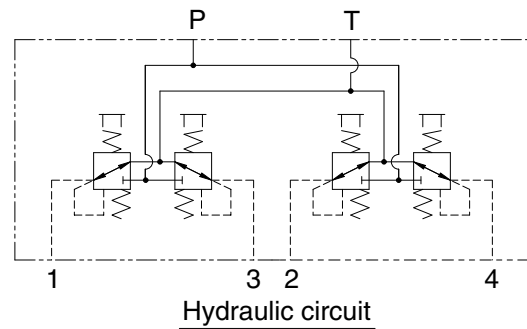

Pilot ports

Port	LH	RH	Port size
P	Pilot oil inlet port	Pilot oil inlet port	PF 3/8
T	Pilot oil return port	Pilot oil return port	
1	Left swing port	Bucket out port	
2	Arm out port	Boom up port	
3	Right swing port	Bucket in port	
4	Arm in port	Boom down port	

480A2RL01

2) TYPE M11, M12

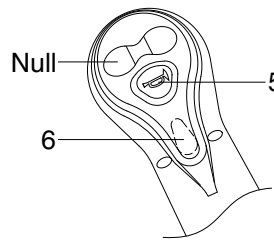
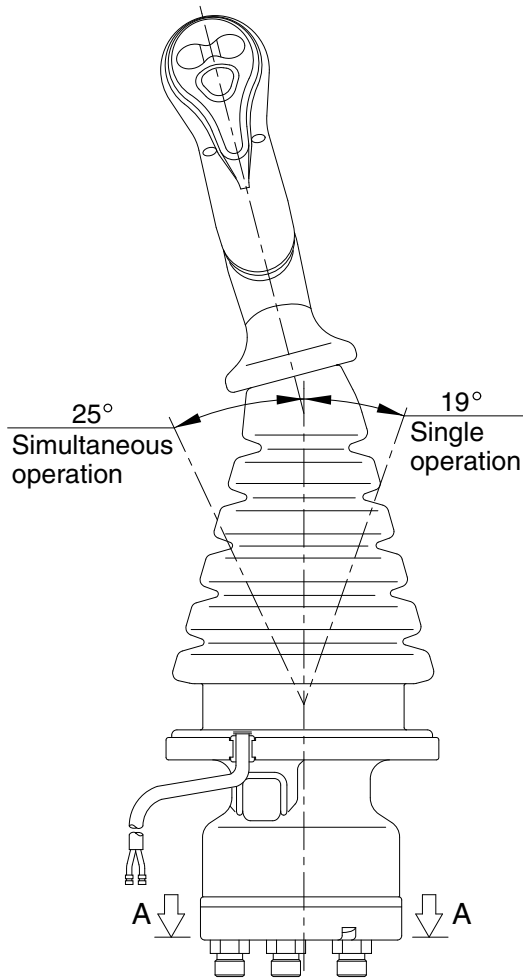

TYPE M12

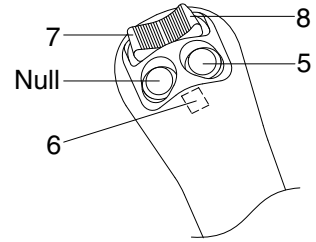

TYPE M11

Switches

Type	No.	LH	RH
M12	5	One touch decel	Horn
	6	Power boost	Breaker
M11	5	One touch decel	Horn
	6	Power boost	Null
	7	CCW rotation	Close
	8	CW rotation	Open

※ Number 7 and 8 : Option attachment

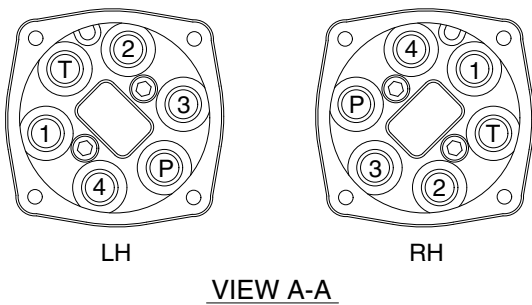
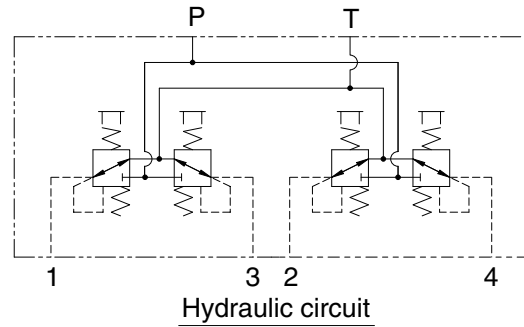

Pilot ports

Port	LH	RH	Port size
P	Pilot oil inlet port	Pilot oil inlet port	PF 3/8
T	Pilot oil return port	Pilot oil return port	
1	Left swing port	Bucket out port	
2	Arm out port	Boom up port	
3	Right swing port	Bucket in port	
4	Arm in port	Boom down port	

480A2RL05

3) CROSS SECTION

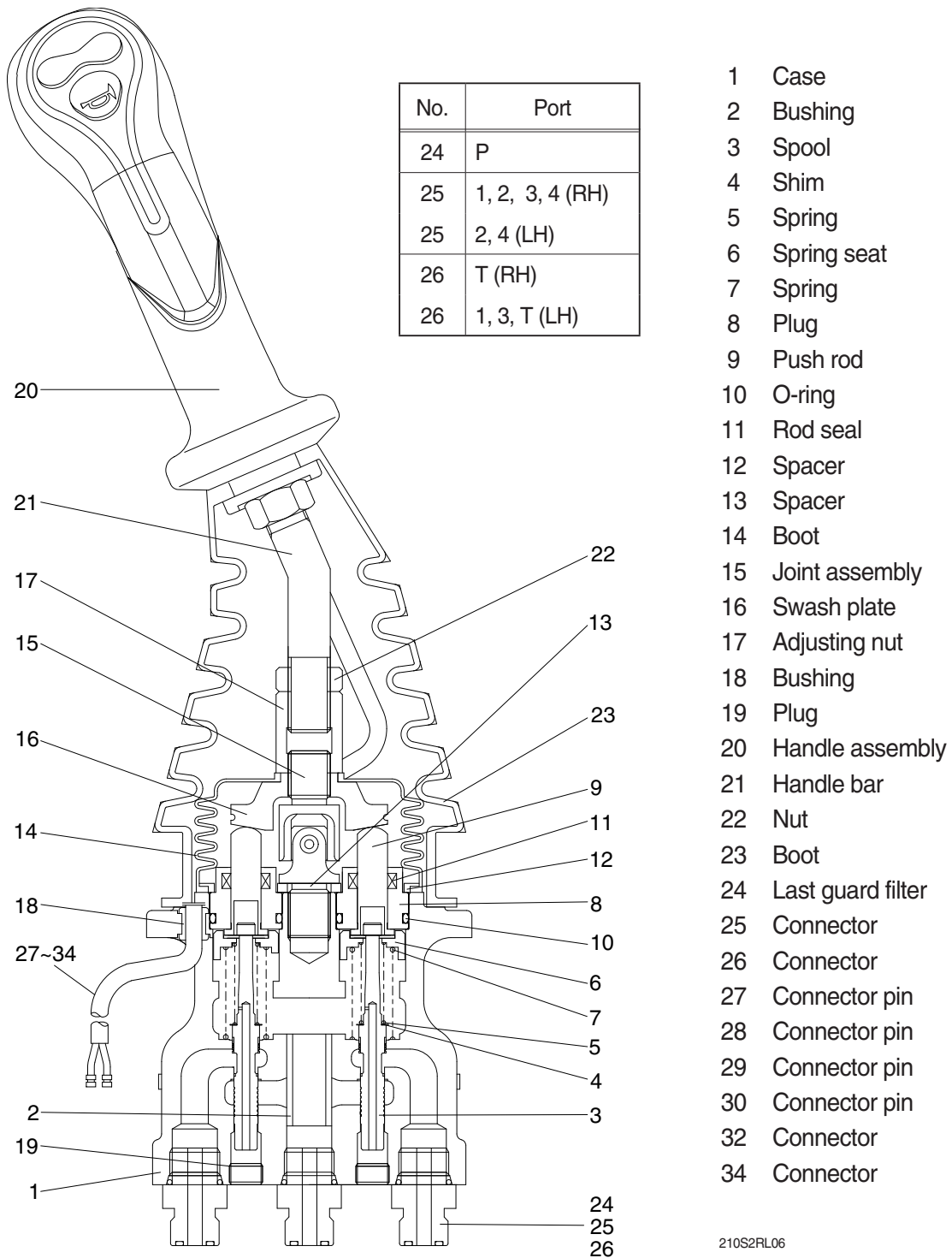

- 1 Case
- 2 Bushing
- 3 Spool
- 4 Shim
- 5 Spring
- 6 Spring seat
- 7 Spring
- 8 Plug
- 9 Push rod
- 10 O-ring
- 11 Rod seal
- 12 Spacer
- 13 Spacer
- 14 Boot
- 15 Joint assembly
- 16 Swash plate
- 17 Adjusting nut
- 18 Bushing
- 19 Plug
- 20 Handle assembly
- 21 Handle bar
- 22 Nut
- 23 Boot
- 24 Last guard filter
- 25 Connector
- 26 Connector
- 27 Connector pin
- 28 Connector pin
- 29 Connector pin
- 30 Connector pin
- 32 Connector
- 34 Connector

210S2RL06

Item numbers are based on the type M1.

The construction of the pilot valve is shown in the attached cross section drawing. The casing has vertical holes in which reducing valves are assembled.

The pressure reducing section is composed of the spool (3), spring (5) for setting secondary pressure, return spring (7), spring seat (6) and shim (4). The spring for setting the secondary pressure has been generally so preset that the secondary pressure is 5 to 20.5 kgf/cm² (depending on the type). The spool is pushed against the push rod (9) by the return spring.

When the push rod is pushed down by tilting the handle, the spring seat comes down simultaneously and changes setting of the secondary pressure spring.

2. FUNCTIONS

1) FUNDAMENTAL FUNCTIONS

The pilot valve is a valve that controls the spool stroke, direction, etc of a main control valve. This function is carried out by providing the spring at one end of the main control valve spool and applying the output pressure (secondary pressure) of the pilot valve to the other end.

For this function to be carried out satisfactorily, the pilot valve is composed of the following elements.

- (1) Inlet port (P) where oil is supplied from hydraulic pump.
- (2) Output ports (1, 2, 3 & 4) to apply pressure supplied from inlet port to ends of control valve spools.
- (3) Tank port (T) necessary to control the above output pressure.
- (4) Spool to connect output port to inlet port or tank port.
- (5) Mechanical means to control output pressure, including springs that work on the above spools.

2) FUNCTIONS OF MAJOR SECTIONS

Item numbers are based on the type M1.

The functions of the spool (3) are to receive the supply oil pressure from the hydraulic pump at its port P, and to change over oil paths to determine whether the pressure oil of port P is led to output ports 1, 2, 3 & 4 or the output port pressure oil to tank port T.

The spring (5) works on this spool to determine the output pressure.

The change the deflection of this spring, the push rod (9) is inserted and can slide in the plug (8).

For the purpose of changing the displacement of the push rod through the swash plate (16) and adjusting nut (17) are provided the handle assy (20) that can be tilted in any direction around the fulcrum of the universal joint (15) center.

The spring (7) works on the case (1) and spring seat (6) and tries to return the push rod (9) to the zero-displacement position irrespective of the output pressure, securing its resetting to the center position.

This also has the effect of a reaction spring to give appropriate control feeling to the operator.

3) OPERATION

The operation of the pilot valve will be described on the basis of the hydraulic circuit diagram shown below and the attached operation explanation drawing.

The diagram shown below is the typical application example of the pilot valve.

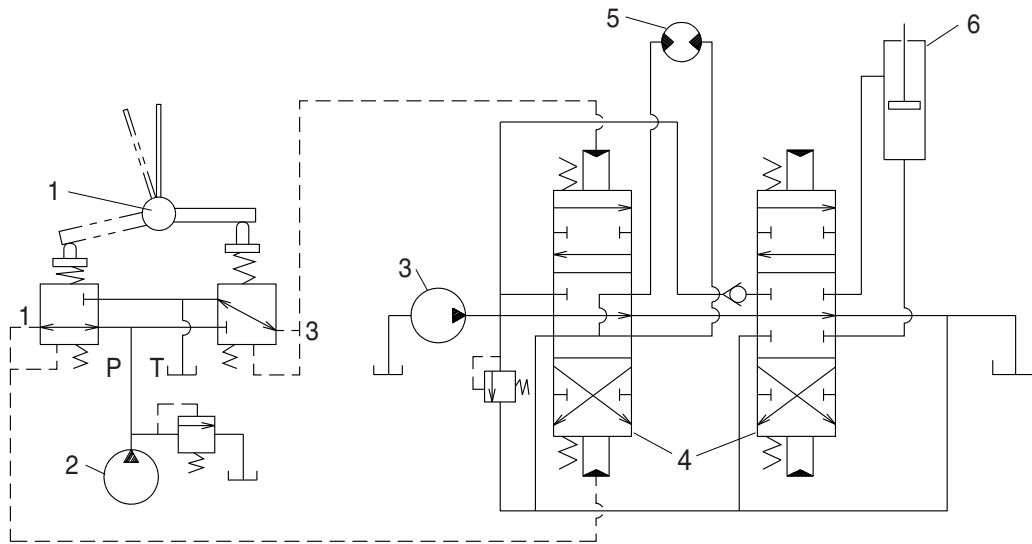

2-70

- 1 Pilot valve
- 2 Pilot pump

- 3 Main pump
- 4 Main control valve

- 5 Hydraulic motor
- 6 Hydraulic cylinder

(1) Case where handle is in neutral position

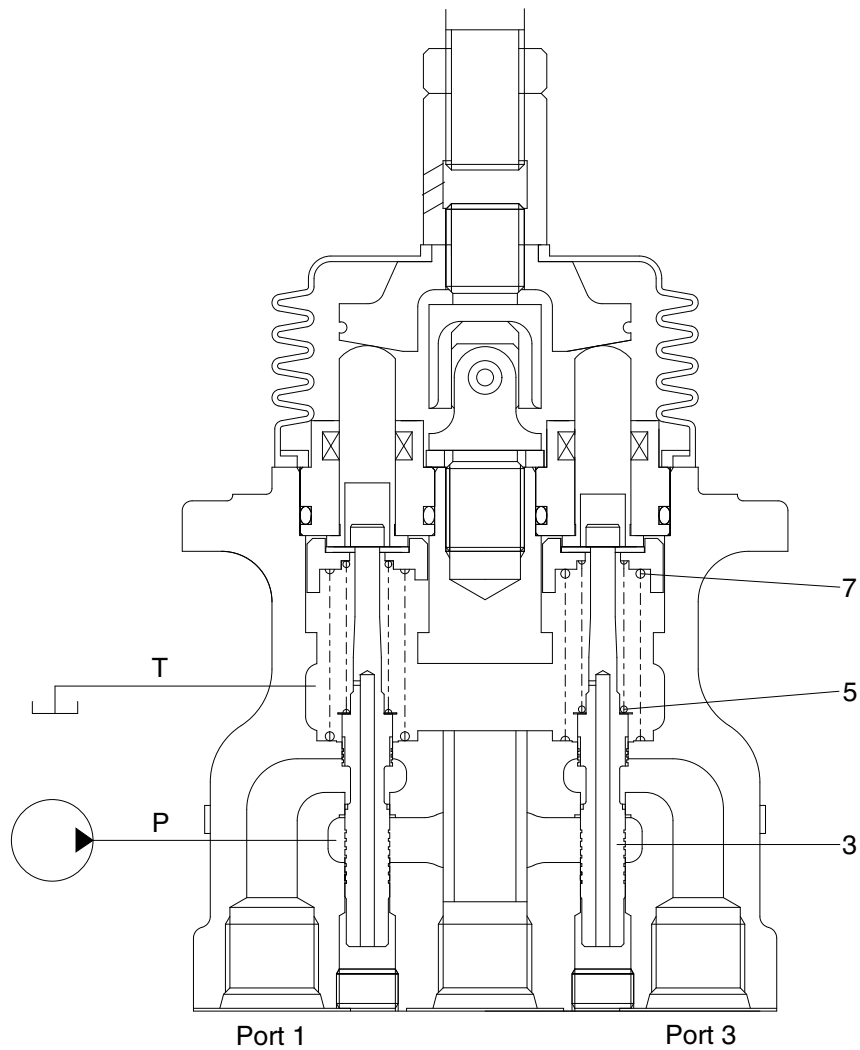

300L2RL03

The force of the spring (5) that determines the output pressure of the pilot valve is not applied to the spool (3). Therefore, the spool is pushed up by the spring (7) to the position of port (1, 3) in the operation explanation drawing. Then, since the output port is connected to tank port T only, the output port pressure becomes equal to tank pressure.

(2) Case where handle is tilted

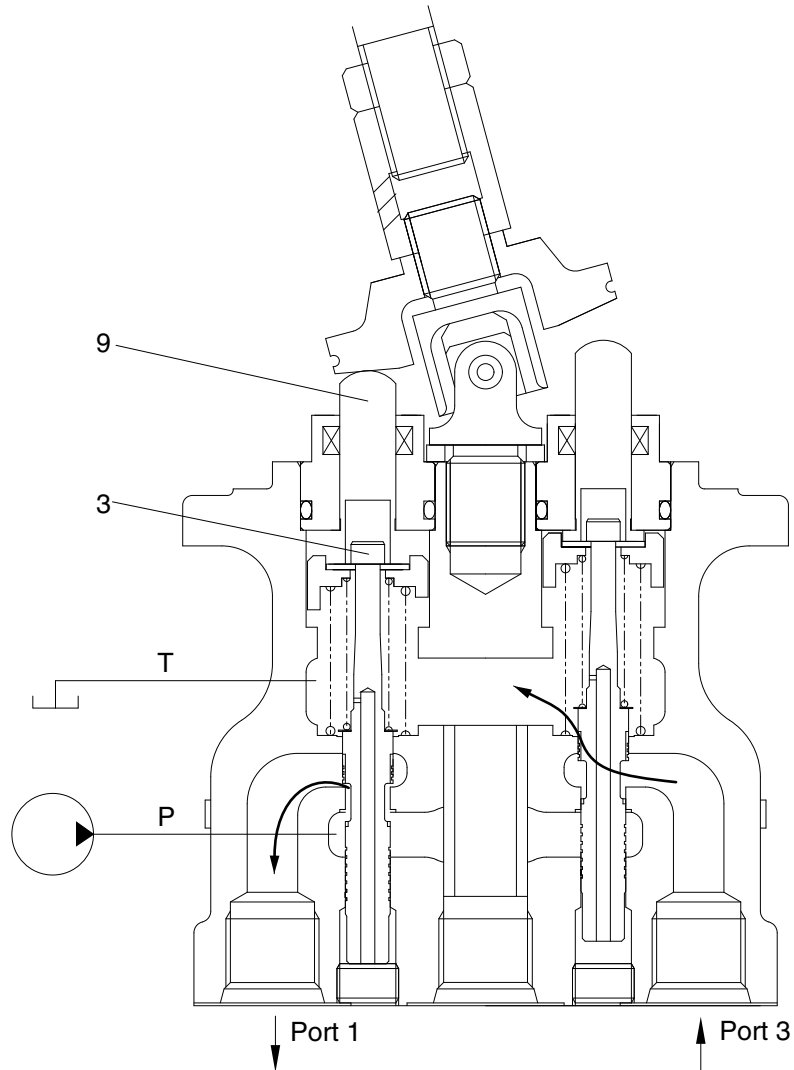

300L2RL04

When the push rod (9) is stroked, the spool (3) moves downwards.

Then port P is connected with port (1) and the oil supplied from the pilot pump flows through port (1) to generate the pressure.

When the pressure at port (1) increases to the value corresponding to the spring force set by tilting the handle, the hydraulic pressure force balances with the spring force. If the pressure at port (1) increases higher than the set pressure, port P is disconnected from port (1) and port T is connected with port (1). If it decreases lower than the set pressure, port P is connected with port (1) and port T is disconnected from port 1.

In this manner the secondary pressure is kept at the constant value.

Besides, in some type, when the handle is tilted more than a certain angle, the upper end of the spool contacts with the inside bottom of the push rod and the output pressure is left to be connected with port P.

GROUP 6 RCV PEDAL

1. STRUCTURE

The casing (spacer) has the oil inlet port P (primary pressure), and the oil outlet port T (tank). In addition the secondary pressure is taken out through ports 1, 2, 3 and 4 provided at the bottom face.

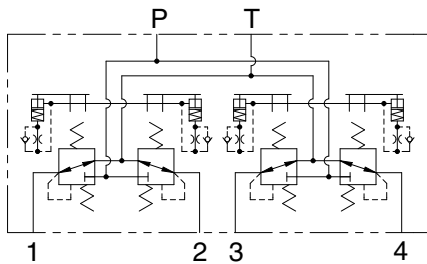
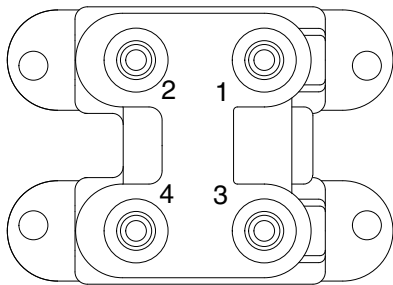
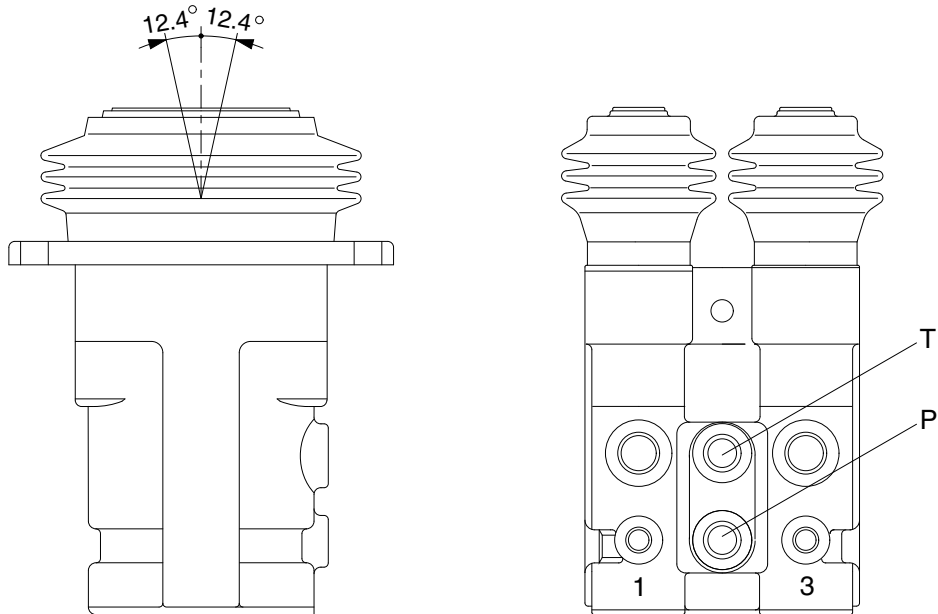

Hydraulic circuit

Port	Port	Port size
P	Pilot oil inlet port	PF 1/4
T	Pilot oil return port	
1	Travel (LH, Forward)	
2	Travel (LH, Backward)	
3	Travel (RH, Forward)	
4	Travel (RH, Backward)	

130ZF2RP01

CROSS SECTION

The construction of the RCV pedal is shown in the below drawing. The casing has vertical holes in which reducing valves are assembled.

The pressure reducing section is composed of the spool (7), spring (5) for setting secondary pressure, return spring (9), stopper (8), and spring seat (6). The spring for setting the secondary pressure has been generally so preset that the secondary pressure is 6.3 ± 1 to 24.9 ± 1.5 kgf/cm² (depending on the type). The spool is pushed against the push rod (13) by the return spring.

When the push rod is pushed down by tilting pedal, the spring seat comes down simultaneously and changes setting of the secondary pressure spring.

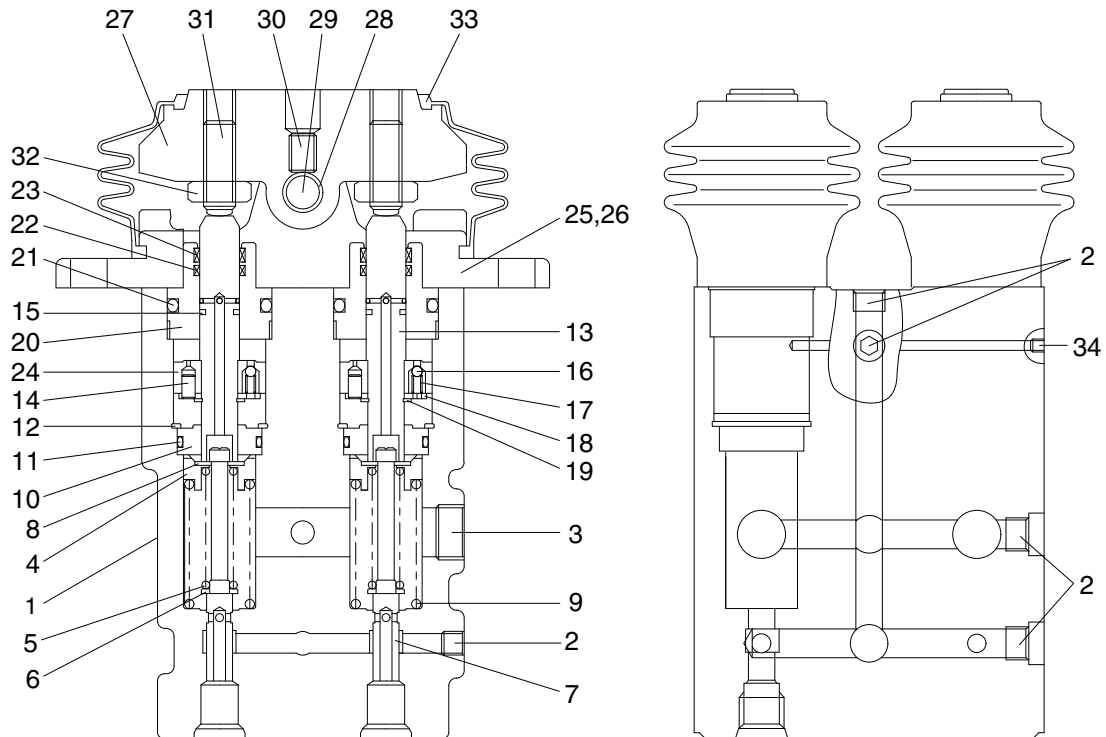

130ZF2RP02

1	Body	13	Push rod	25	Cover
2	Plug	14	Spring pin	26	Wrench bolt
3	Plug	15	Seal	27	Cam
4	Spring seat	16	Steel ball	28	Bushing
5	Spring	17	Spring	29	Cam shaft
6	Spring seat	18	Plate	30	Set screw
7	Spool	19	Snap ring	31	Set screw
8	Stopper	20	Plug	32	Hex nut
9	Spring	21	O-ring	33	Bellows
10	Rod guide	22	Rod seal	34	Expand
11	O-ring	23	Dust seal	35	Name plate
12	Snap ring	24	Piston		

2. FUNCTION

1) FUNDAMENTAL FUNCTIONS

The pilot valve is a valve controls the spool stroke, direction, etc of a main control valve. This function is carried out by providing the spring at one end of the main control valve spool and applying the output pressure (secondary pressure) of the pilot valve to the other end.

For this function to be carried out satisfactorily, the pilot valve is composed of the following elements.

- (1) Inlet port (P) where oil is supplied from hydraulic pump.
- (2) Output port (1, 2, 3 & 4) to apply pressure supplied from inlet port to ends of control valve spools.
- (3) Tank port (T) necessary to control the above output pressure.
- (4) Spool to connect output port to inlet port tank port.
- (5) Mechanical means to control output pressure, including springs that work on the above spools.

2) FUNCTIONS OF MAJOR SECTIONS

The functions of the spool (7) are to receive the supply oil pressure from the hydraulic pump at its port P, and to change over oil paths to determine whether the pressure oil of port P is led to output ports 1, 2, 3 & 4 or the output spool to determine the output pressure.

The spring (5) works on this spool to determine the output pressure.

The change the deflection of this spring, the push rod (13) is inserted and can slide in the plug (20). For the purpose of changing th displacement of the push rod through the cam (27) and adjusting nut (32) are provided the pedal that can be tilted in any direction around the fulcrum of the cam (27) center.

The spring (9) works on the body (1) and spring seat (6) and tries to return the push rod (13) to the zero-displacement position irrespective of the output pressure, securing its resetting to the center position.

This also has the effect of a reaction spring to give appropriate control feeling to the operator.

3) OPERATION

The operation of the pilot valve will be described on the basis of the hydraulic circuit diagram shown below and the attached operation explanation drawing.

The diagram shown below is the typical application example of the pilot valve.

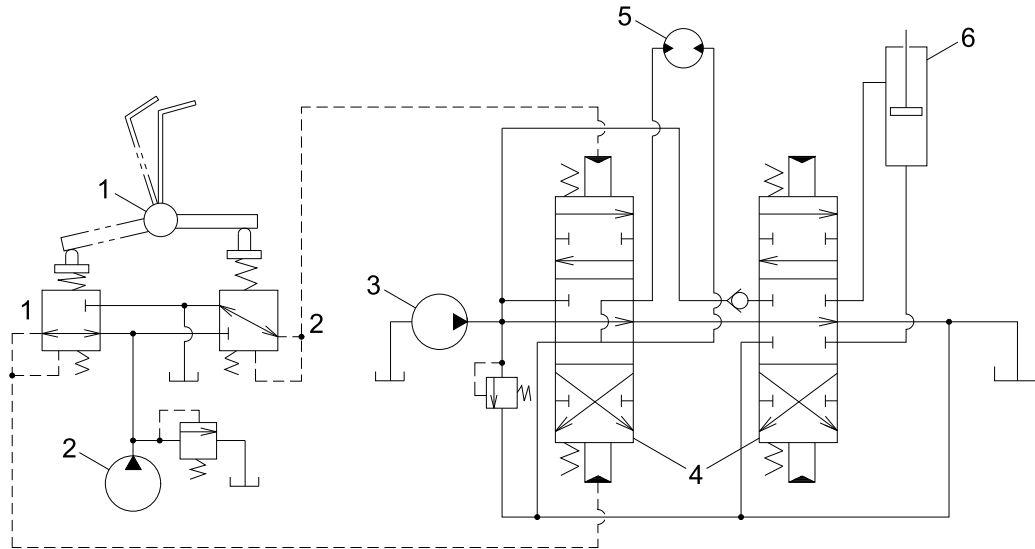

36072SF01

1 Pilot valve
2 Pilot pump

3 Main pump
4 Main control valve

5 Hydraulic motor
6 Hydraulic cylinder

(1) Case where pedal is in neutral position

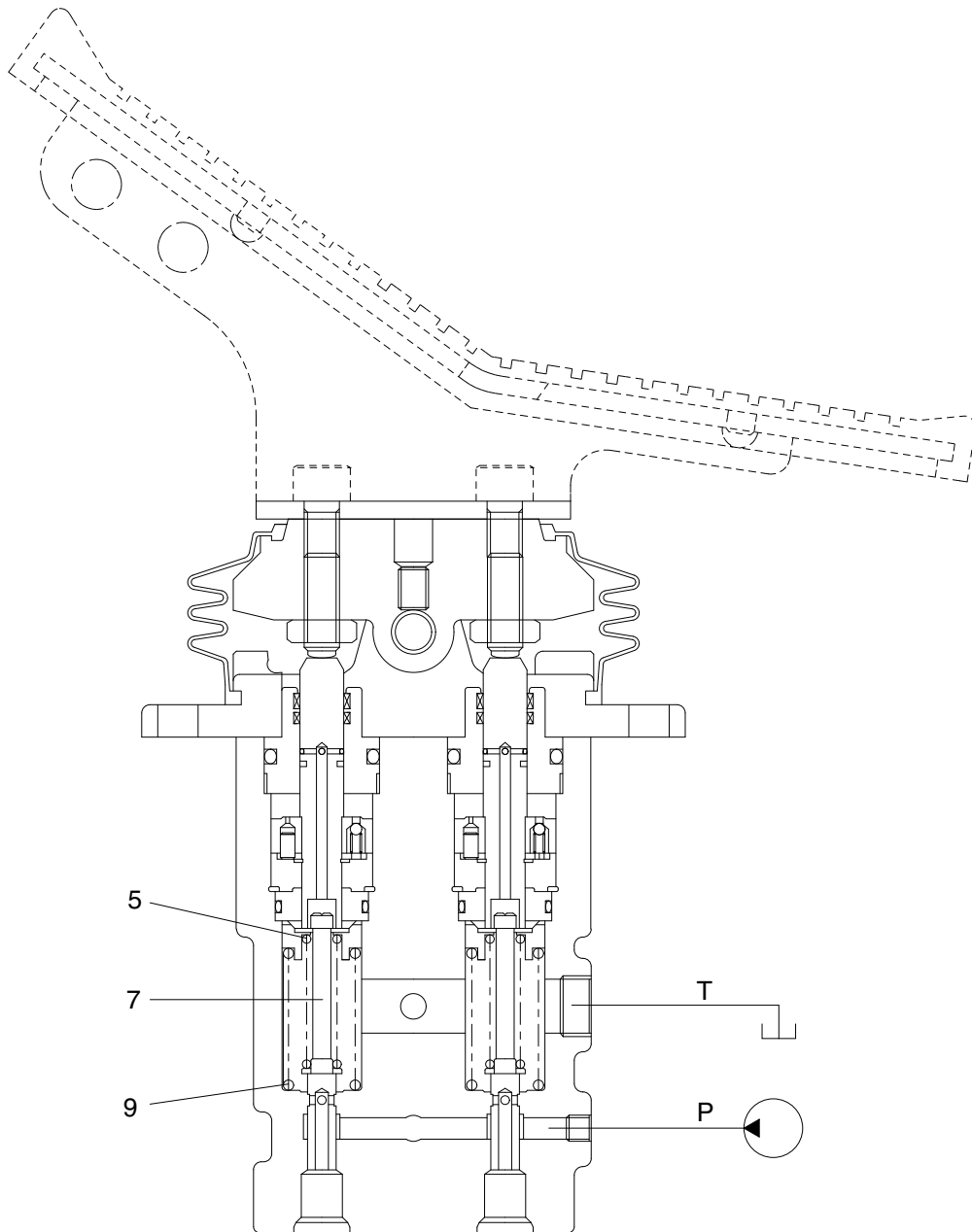

130ZF2RP03

The force of the spring (5) that determines the output pressure of the pilot valve is not applied to the spool (7). Therefore, the spool is pushed up by the spring (9) to the position of 1 and port 2. Then, since the output port is connected to tank port T only, the output port pressure becomes equal to tank pressure.

(2) Case where pedal is tilted

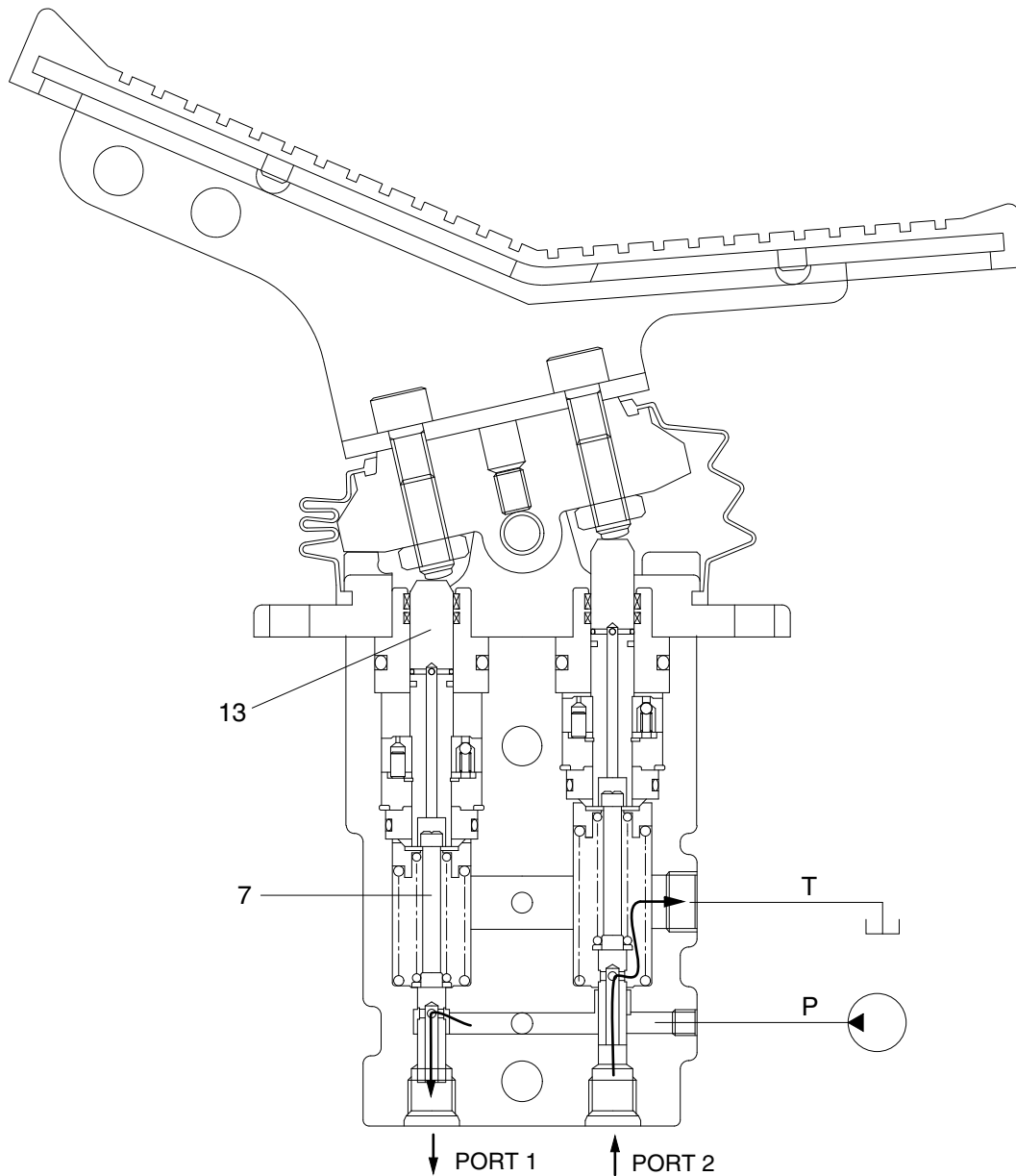

220F2RP04

When the push rod (13) is stroked, the spool (7) moves downwards.

Then port P is connected with port 1, and the oil supplied from the pilot pump flows through port 1 to generate the pressure.

When the pressure at port 1 increases to the value corresponding to the spring force set by tilting the handle, the hydraulic pressure force balances with the spring force. If the pressure at port 1 increases higher than the set pressure, port P is disconnected from port 1 and port T is connected with port 1. If it decreases lower than the set pressure, port P is connected with port 1 and port T is disconnected from port 1.

In this manner the secondary pressure is kept at the constant value.

Besides, in some type, when the handle is tilted more than a certain angle, the upper end of the spool contacts with inside bottom of the push rod and the output pressure is left to be connected with port P.