

SECTION 6 TROUBLESHOOTING

| | |
|---|------|
| Group 1 Before Troubleshooting | 6-1 |
| Group 2 Hydraulic and Mechanical System | 6-4 |
| Group 3 Electrical System | 6-24 |
| Group 4 Mechatronics System | 6-40 |

SECTION 6 TROUBLESHOOTING

GROUP 1 BEFORE TROUBLESHOOTING

1. INTRODUCTION

When a trouble is occurred in the machine, this section will help a service man to repair to maintain the machine with easy.

The trouble of machine is parted Hydraulic & Mechanical system, Electrical system and Mechatronics system. (fault codes displayed on monitor display) At each system part, a service man can check the machine according to the troubleshooting process diagram.

※ Before carrying out troubleshooting procedure, check monitoring menu in the cluster.

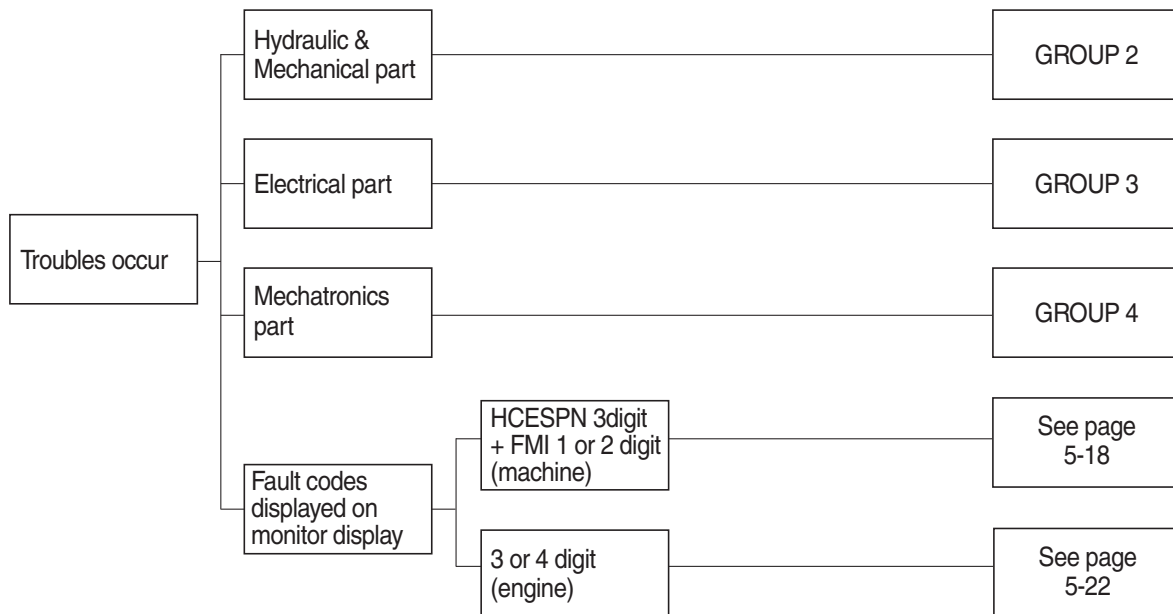

2. DIAGNOSING PROCEDURE

To carry out troubleshooting efficiently, the following steps must be observed.

STEP 1. Study the machine system

Study and know how the machine is operating, how the system is composing, what kinds of function are installed in the machine and what are specifications of the system components by the machine service manual.

Especially, deepen the knowledge for the related parts of the trouble.

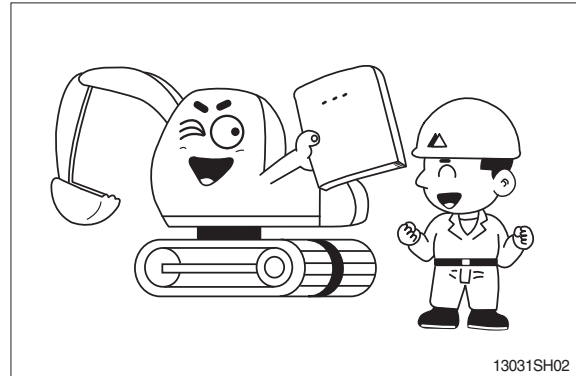

STEP 2. Ask the operator

Before inspecting, get the full story of malfunctions from a witness --- the operator.

- 1) How the machine is used and when it is serviced?
- 2) When the trouble was noticed and what work the machine was doing at that time?
- 3) What is the phenomenon of the trouble?
Was the trouble getting worse, or did it come out suddenly for the first time?
- 4) Did the machine have any troubles previously? If so, which parts were repaired before.

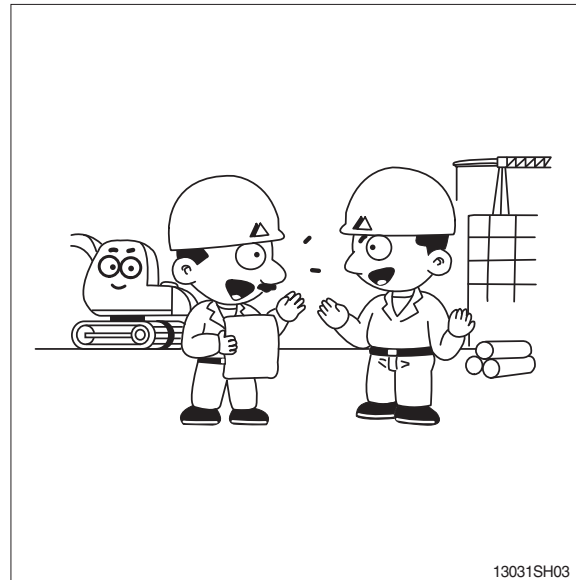

STEP 3. Inspect the machine

Before starting troubleshooting, check the machine for the daily maintenance points as shown in the operator's manual.

And also check the electrical system including batteries, as the troubles in the electrical system such as low battery voltage, loose connections and blown out fuses will result in malfunction of the controllers causing total operational failures of the machine.

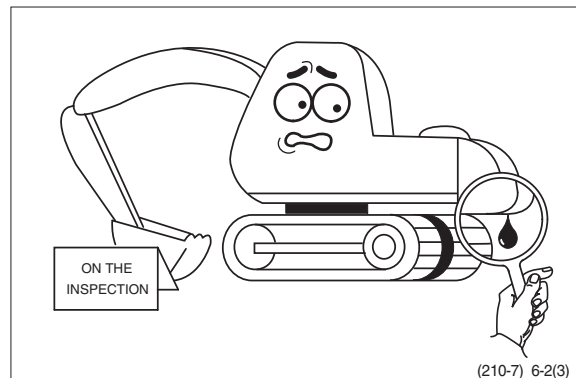

STEP 4. Inspect the trouble actually on the machine

In case that some trouble cannot be confirmed, obtain the details of the malfunction from the operator.

Also, check if there are any incomplete connections of the wire harnesses or not.

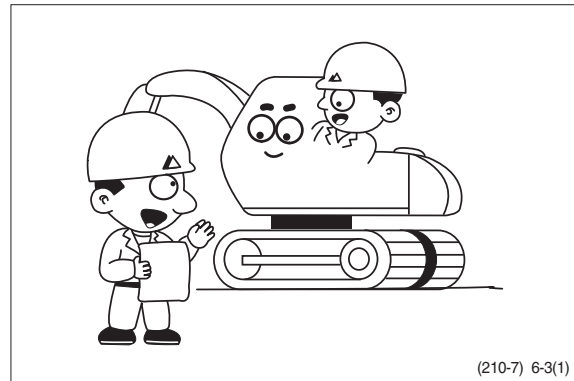

STEP 5. Perform troubleshooting

According to where the trouble parts are located, hydraulic & mechanical system part or electrical system part or mechatronics system part, perform troubleshooting the machine refer to the each system part's troubleshooting process diagram.

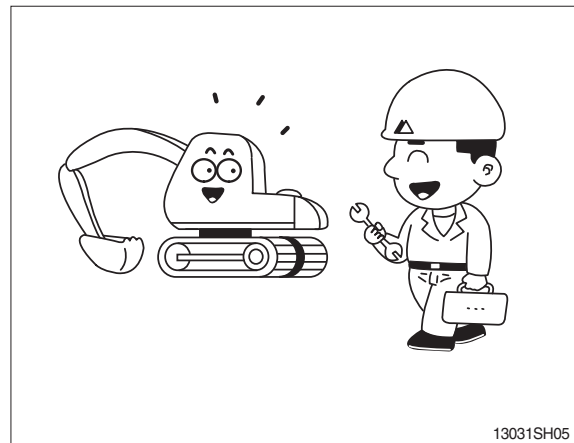

STEP 6. Trace a cause

Before reaching a conclusion, check the most susceptible causes again. Try to trace what the real cause of the trouble is.

Make a plan of the appropriate repairing procedure to avoid consequential malfunctions.

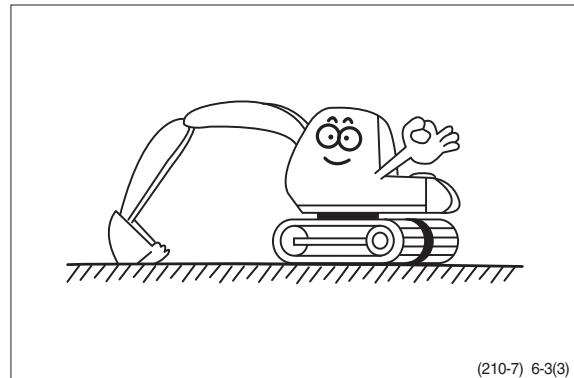

GROUP 2 HYDRAULIC AND MECHANICAL SYSTEM

1. INTRODUCTION

1) MACHINE IN GENERAL

(1) If even a minor fault is left intact and operation is continued, a fatal failure may be caused, entailing a large sum of expenses and long hours of restoration.

Therefore when even a small trouble occurs, do not rely on your intuition and experience, but look for the cause based on the troubleshooting principle and perform maintenance and adjustment to prevent major failure from occurring. Keep in mind that a fault results from a combination of different causes.

(2) The following lists up commonly occurring faults and possible causes with this machine. For the troubleshooting of the engine, refer to the coming troubleshooting and repair.

(3) When carrying out troubleshooting, do not hurry to disassemble the components. It will become impossible to find the cause of the problem.

(4) Ask user or operator the following.

- ① Was there any strange thing about machine before failure occurred?
- ② Under what conditions did the failure occur?
- ③ Have any repairs been carried out before the failure?

(5) Check before troubleshooting.

- ① Check oil and fuel level.
- ② Check for any external leakage of oil from components.
- ③ Check for loose or damage of wiring and connections.

2) MACHINE STATUS MONITORING ON THE CLUSTER

(1) The machine status such as the engine rpm, oil temperature, voltage and pressure etc. can be checked by this menu.

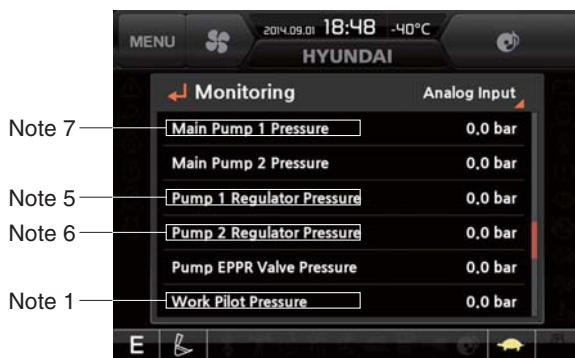

Analog 1



Analog 2

300L6HS01

(2) Specification

| No. | Description | Specification |
|--------|---------------------------|-----------------------------------|
| Note 1 | Work pilot pressure | 40 ⁺² ₀ bar |
| Note 2 | Swing pilot pressure | 0~40 bar |
| Note 3 | Boom up pilot pressure | 0~40 bar |
| Note 4 | Arm/bucket pilot pressure | 0~40 bar |
| Note 5 | Pump 1 regulator pressure | 0~50 bar |
| Note 6 | Pump 2 regulator pressure | 0~50 bar |
| Note 7 | Pump 1 pressure | 350 bar |

2) ENGINE STARTS BUT MACHINE DOES NOT OPERATE AT ALL

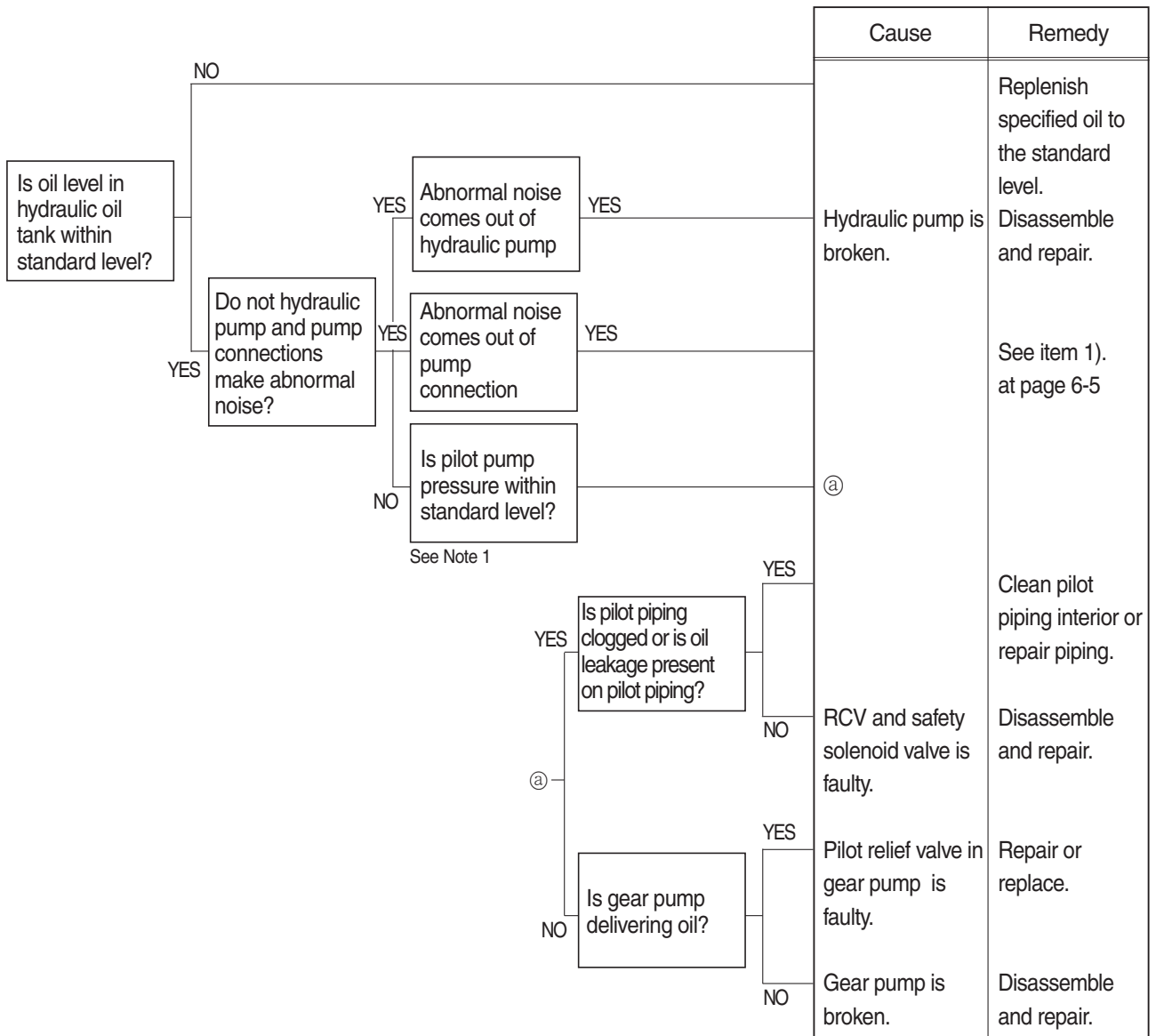

3. HYDRAULIC SYSTEM

1) HYDRAULIC OIL IS CLOUDY

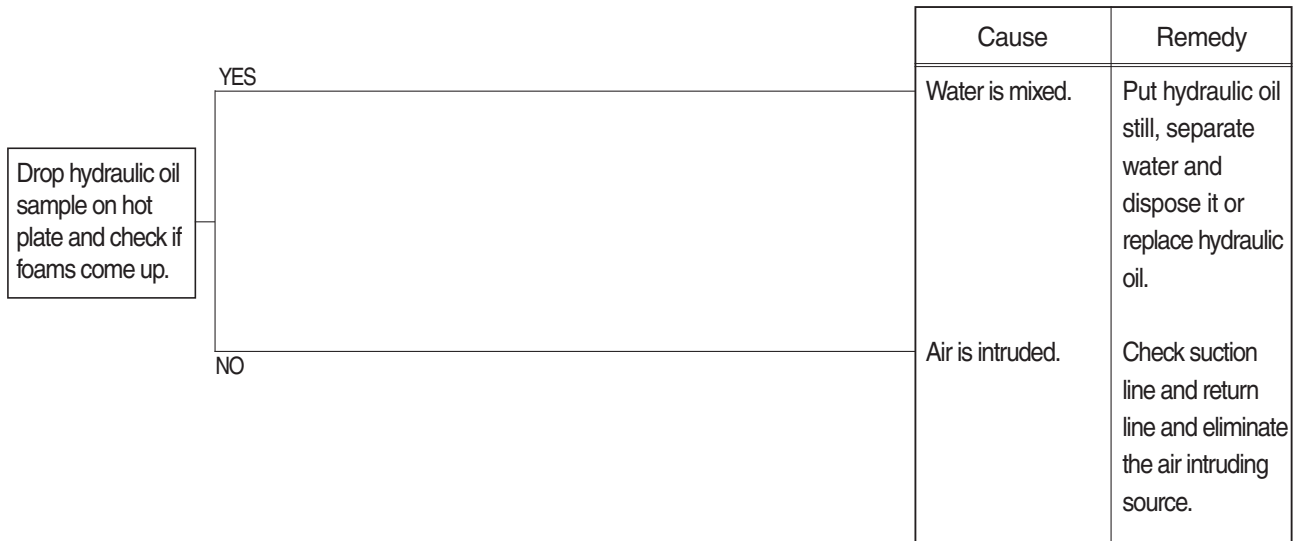

2) HYDRAULIC OIL TEMPERATURE HAS RISEN ABNORMALLY

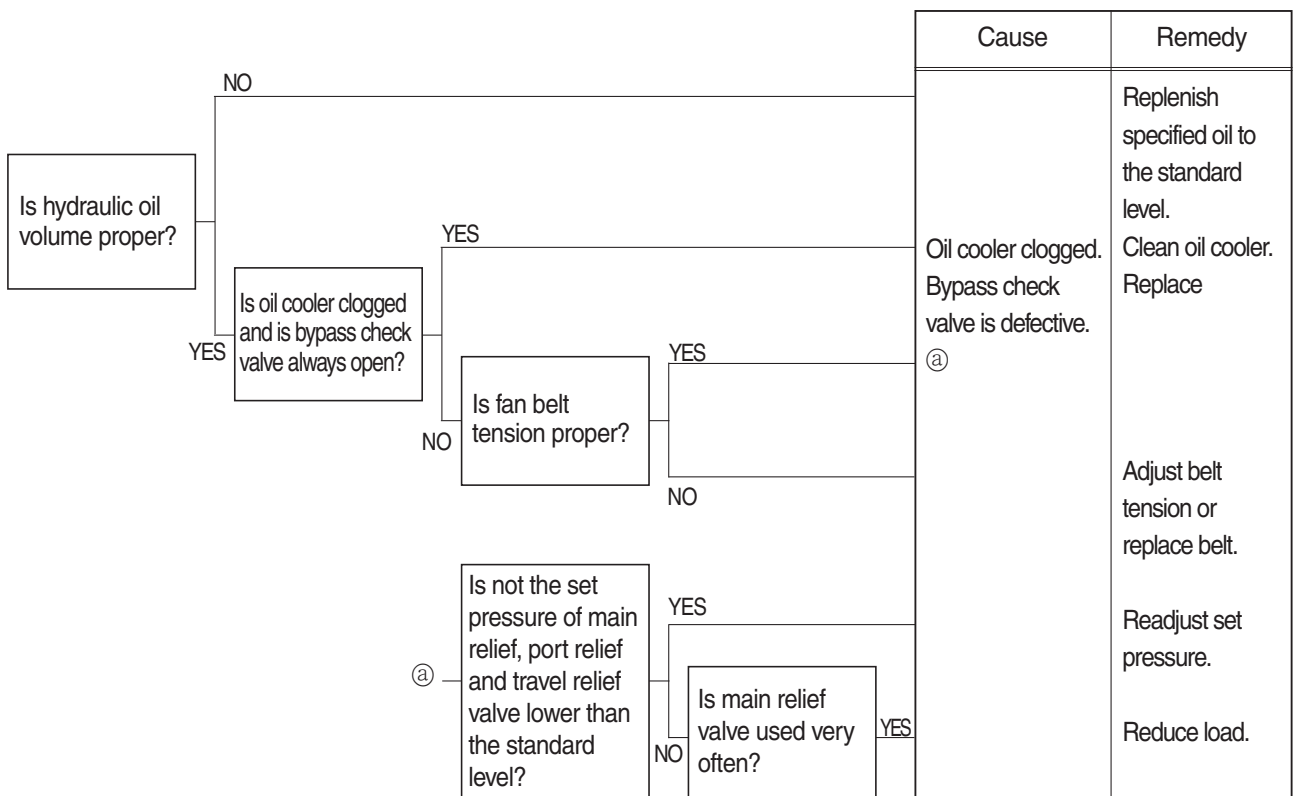

3) CAVITATION OCCURS WITH PUMP

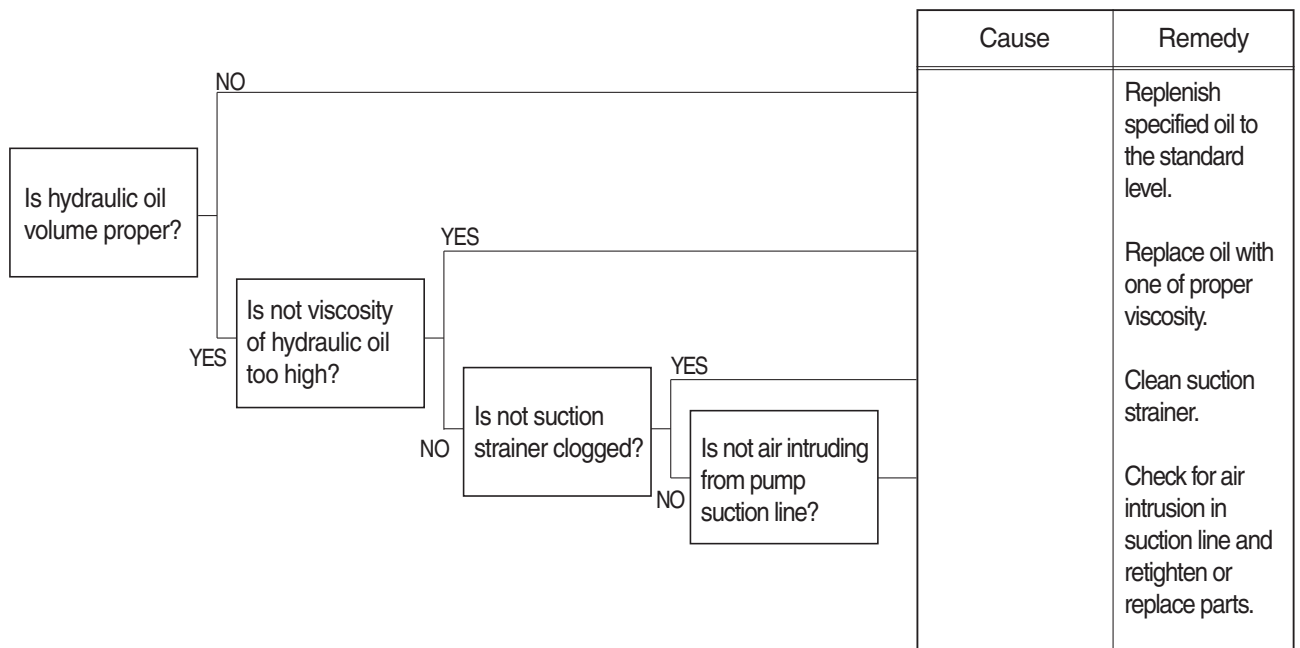

4) HYDRAULIC OIL IS CONTAMINATED

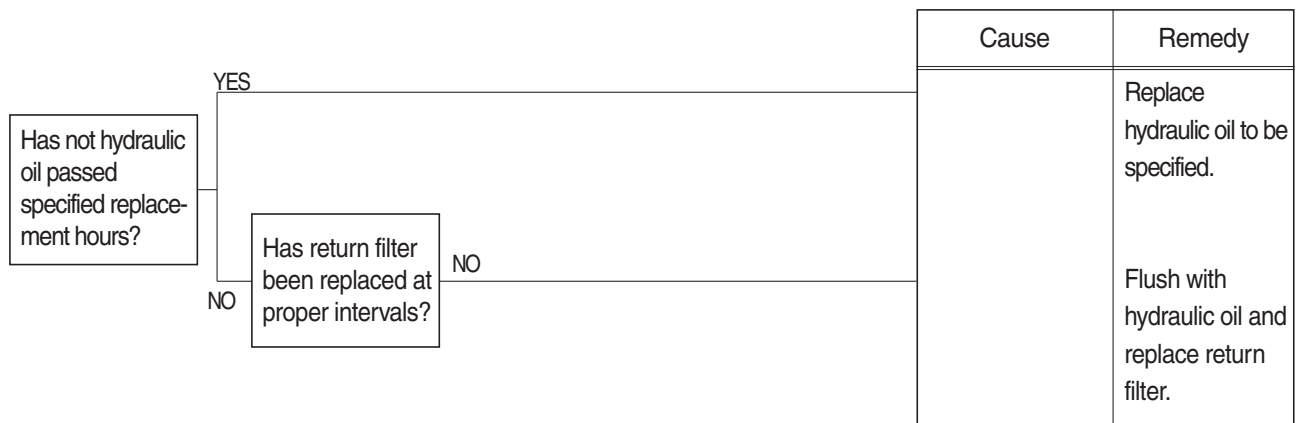

4. SWING SYSTEM

1) BOTH LH AND RH SWING ACTIONS ARE IMPOSSIBLE

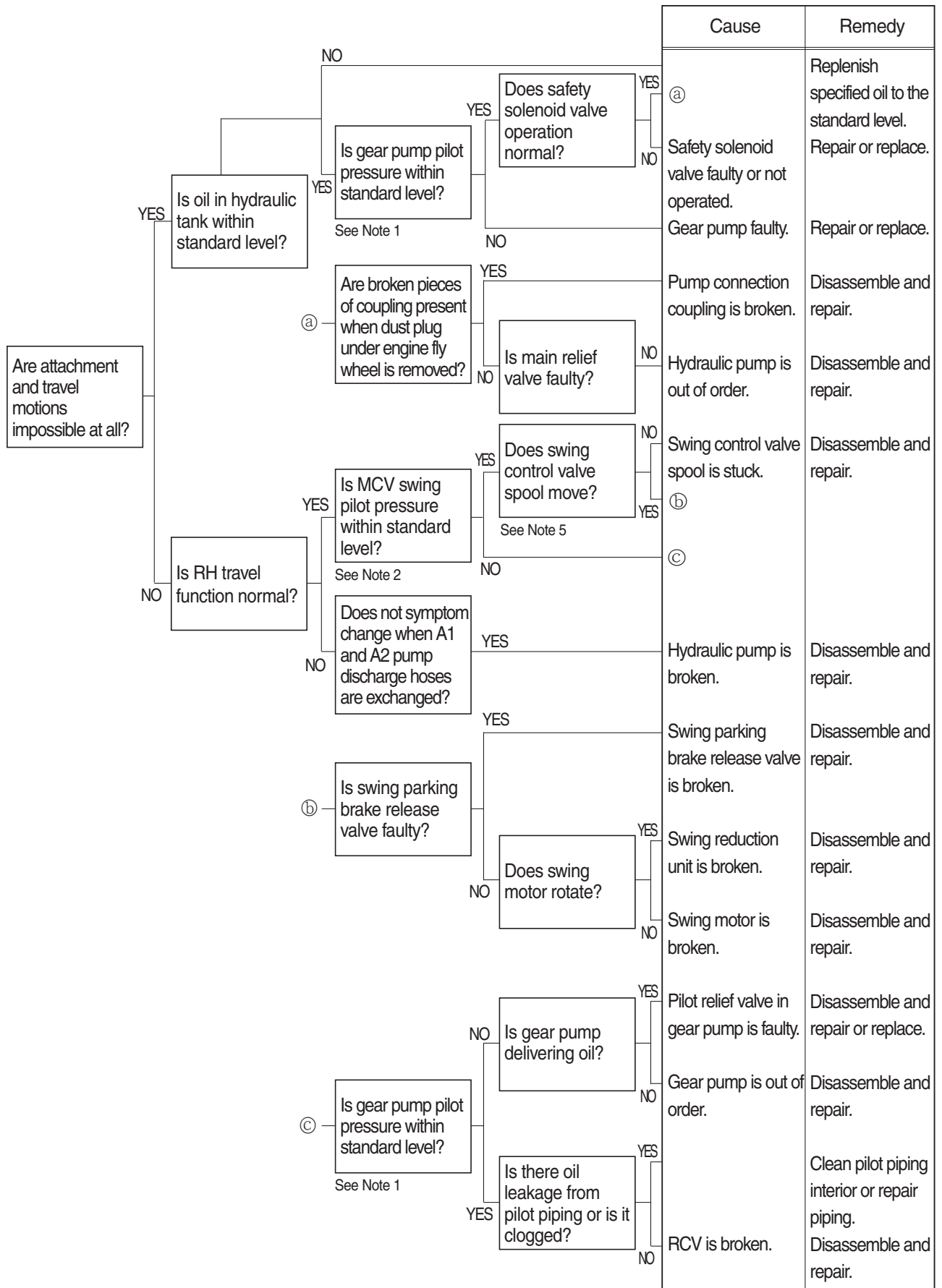

2) SWING SPEED IS LOW

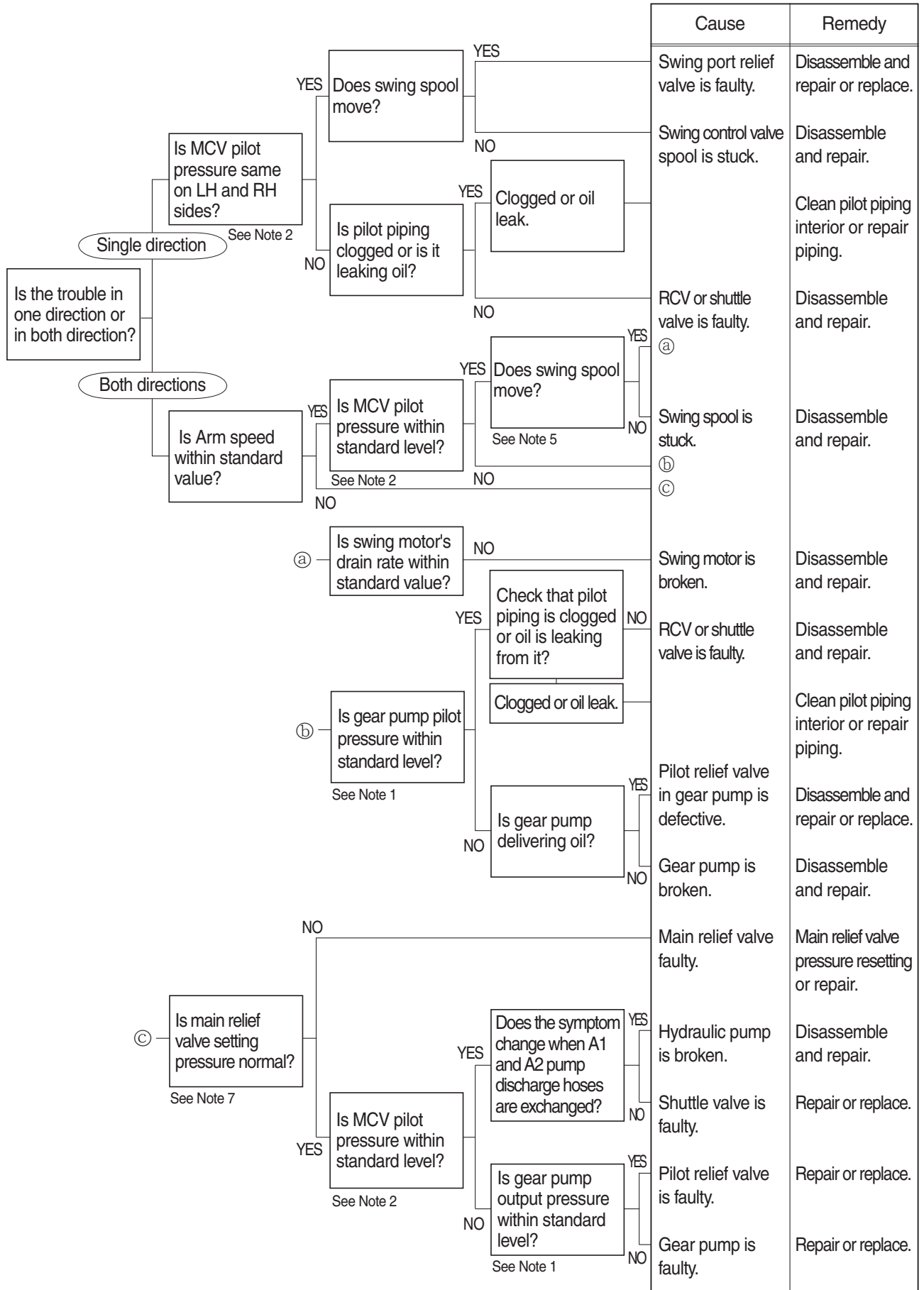

3) SWING MOTION IS IMPOSSIBLE IN ONE DIRECTION

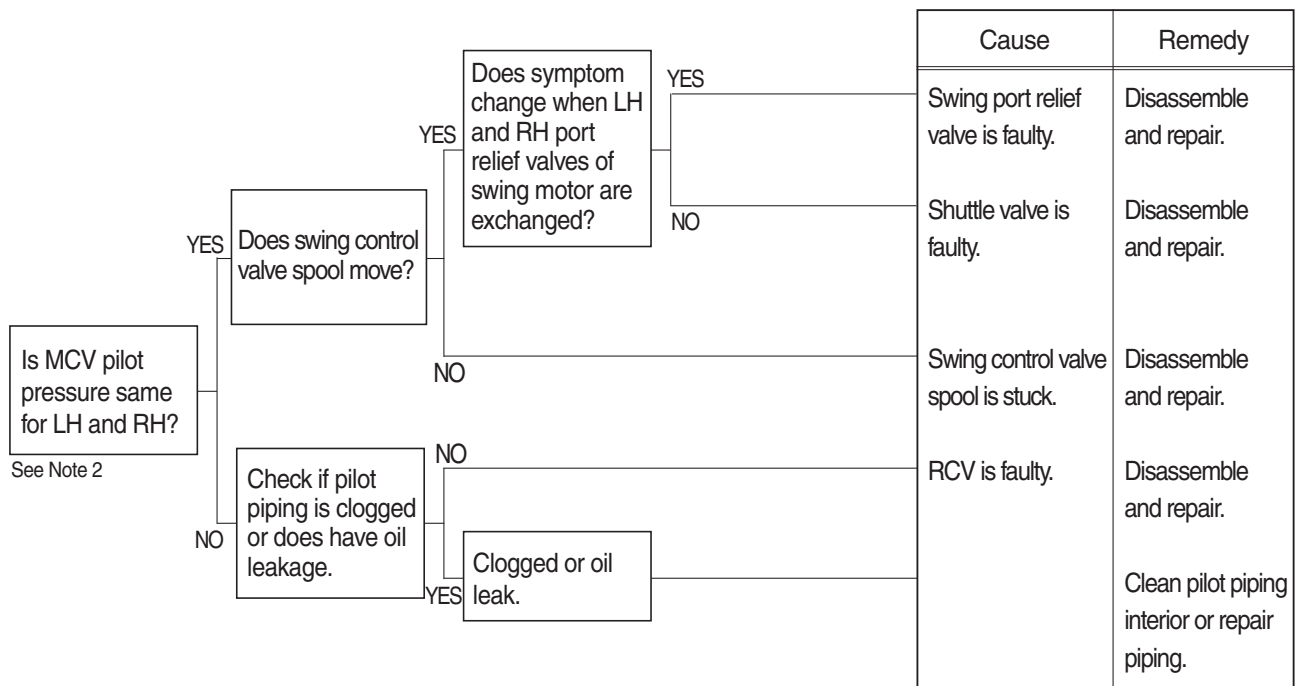

4) MACHINE SWINGS BUT DOES NOT STOP

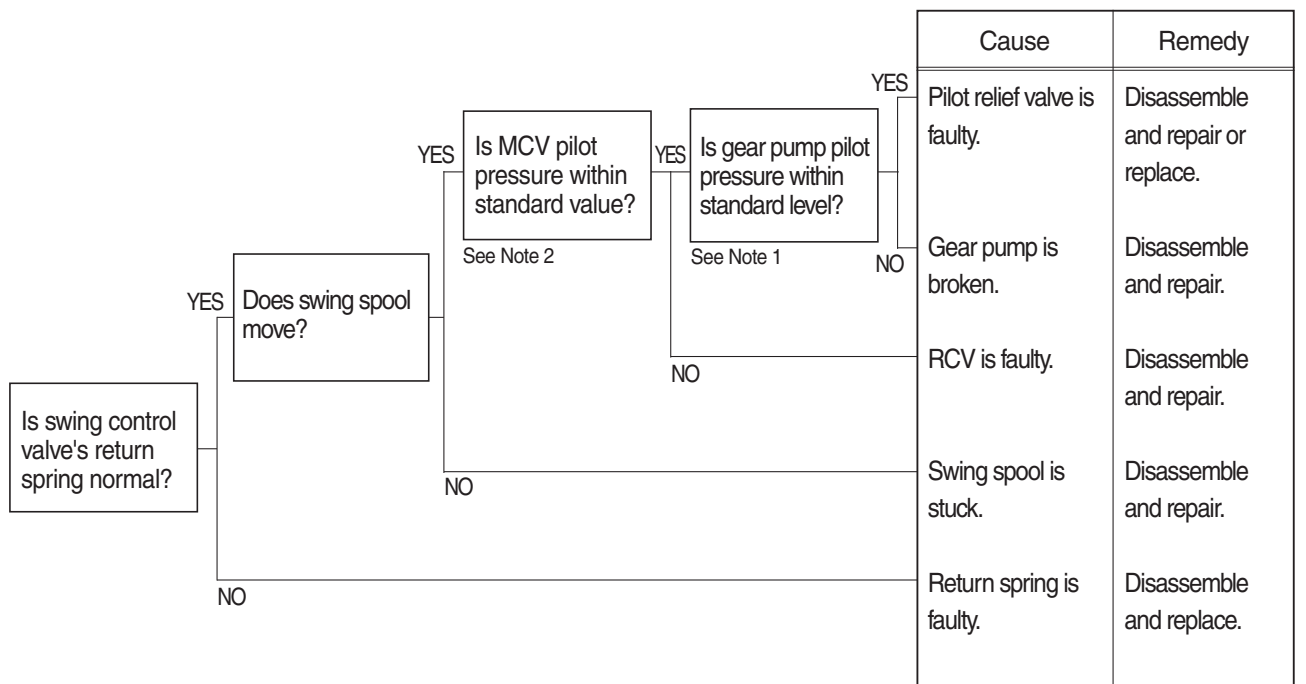

5) THE SWING UNIT DRIFTS WHEN THE MACHINE IS AT REST ON A SLOPE

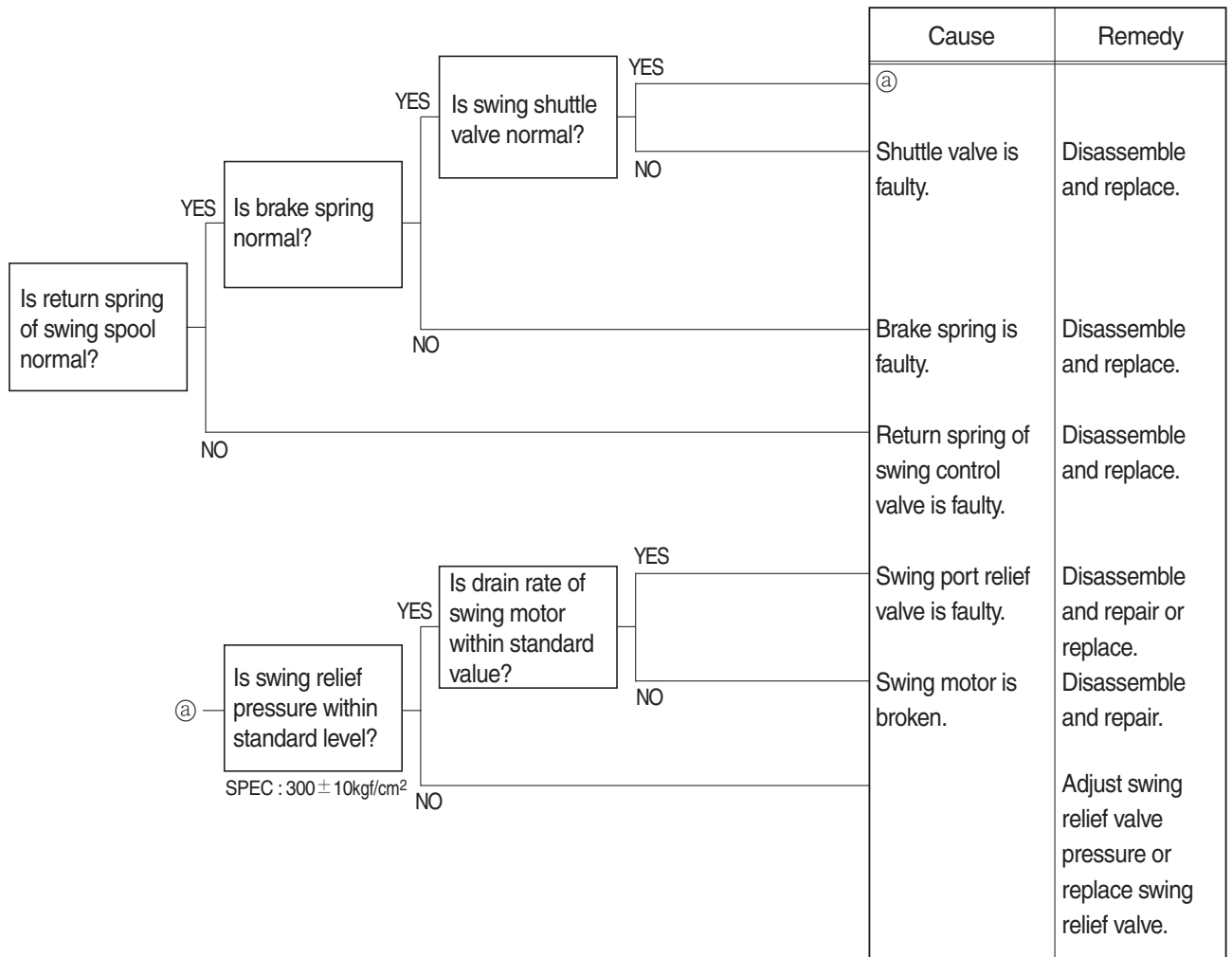

5. TRAVEL SYSTEM

1) TRAVEL DOES NOT FUNCTION AT ALL ON ONE SIDE

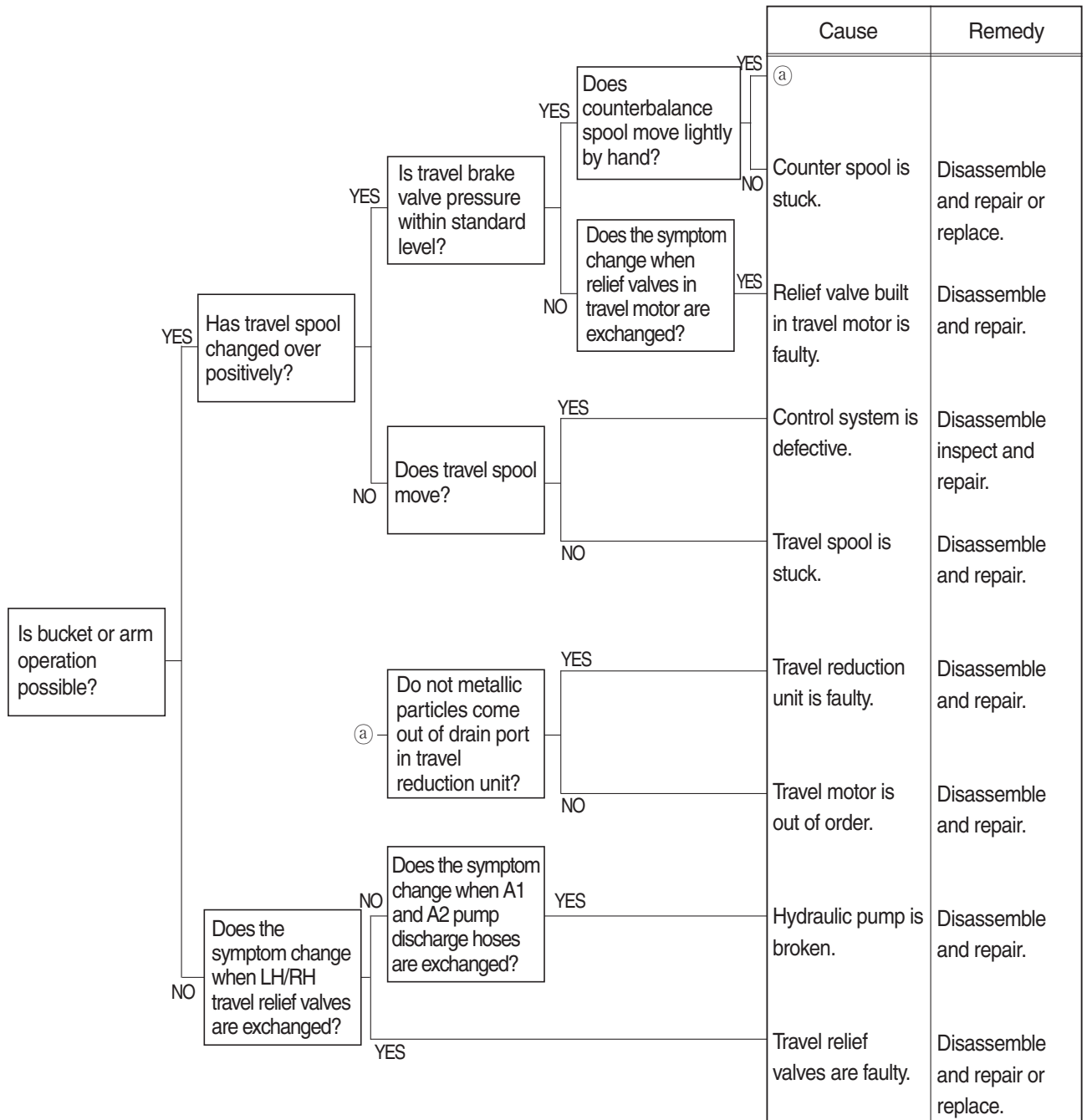

2) SPEED ON ONE SIDE FALLS AND THE MACHINE CURVES

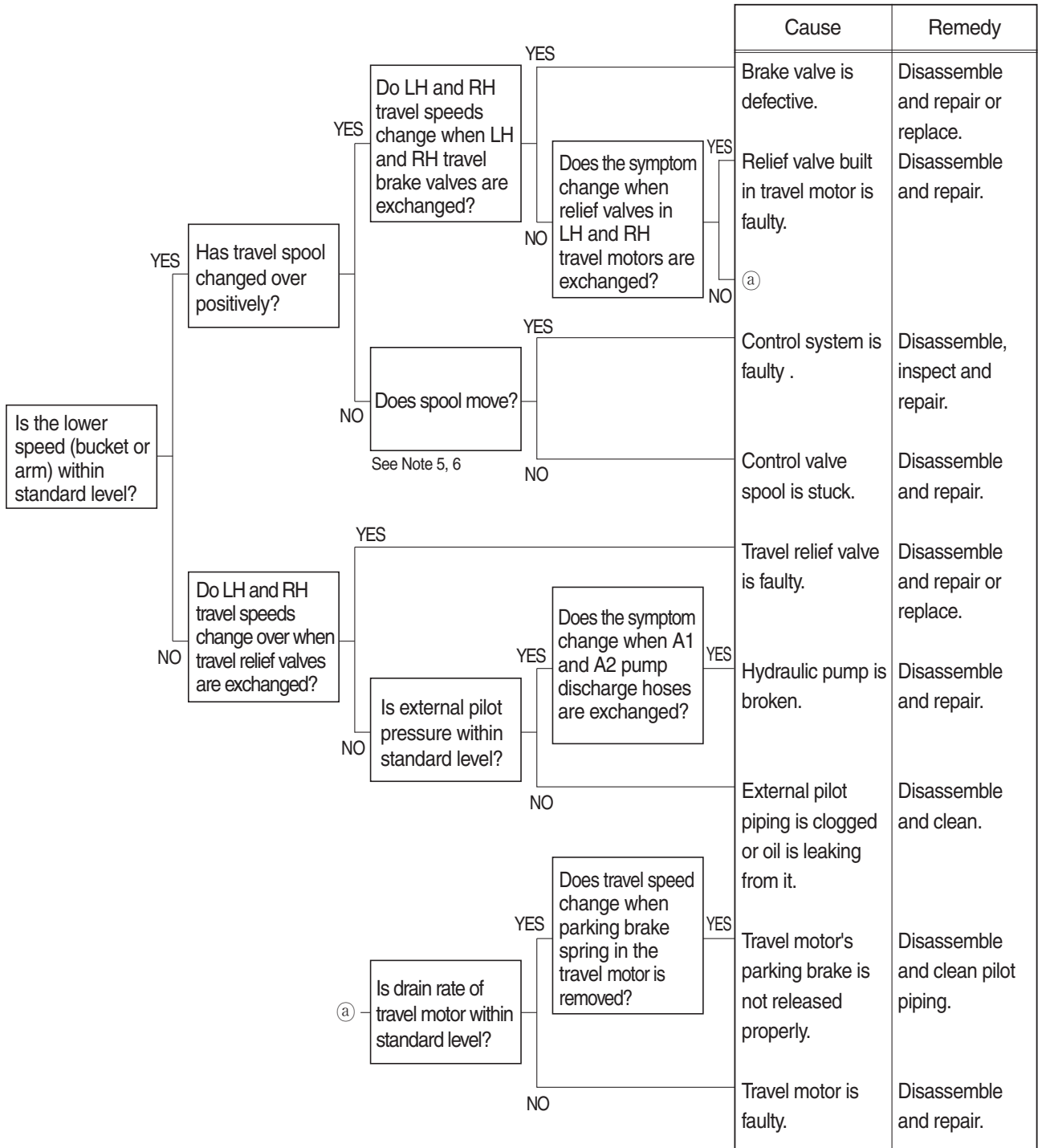

3) MACHINE DOES NOT STOP ON A SLOPE

Machine is pulled forward as sprocket rotates during digging operation.

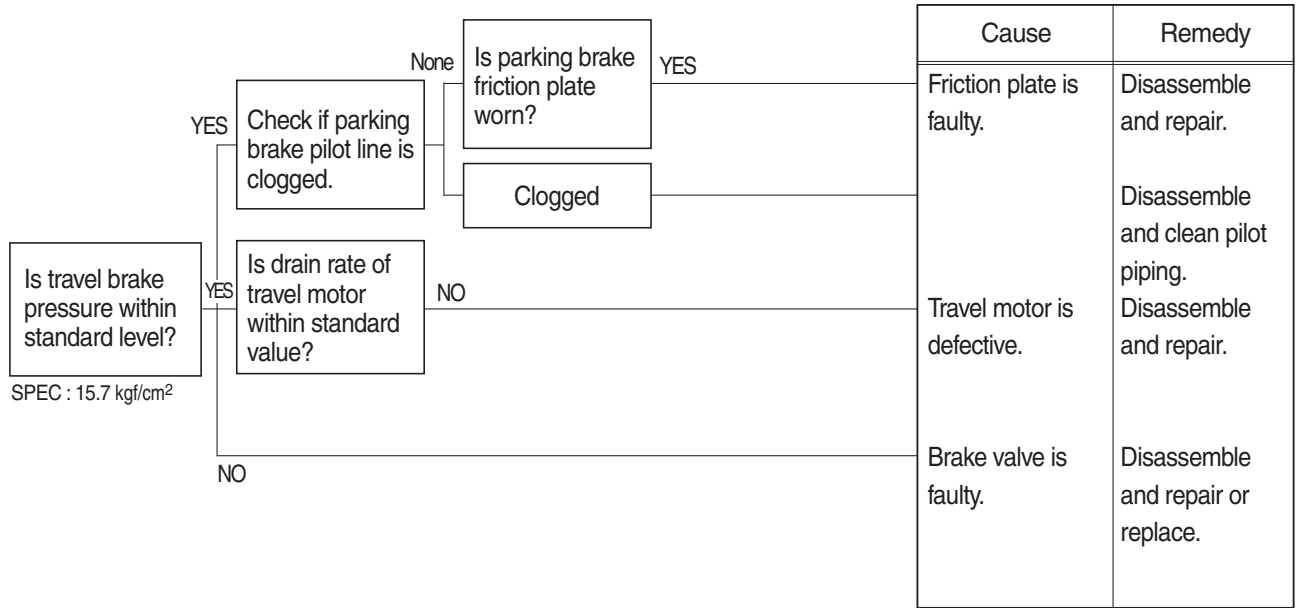

4) LH AND RH TRAVEL MOTIONS ARE IMPOSSIBLE

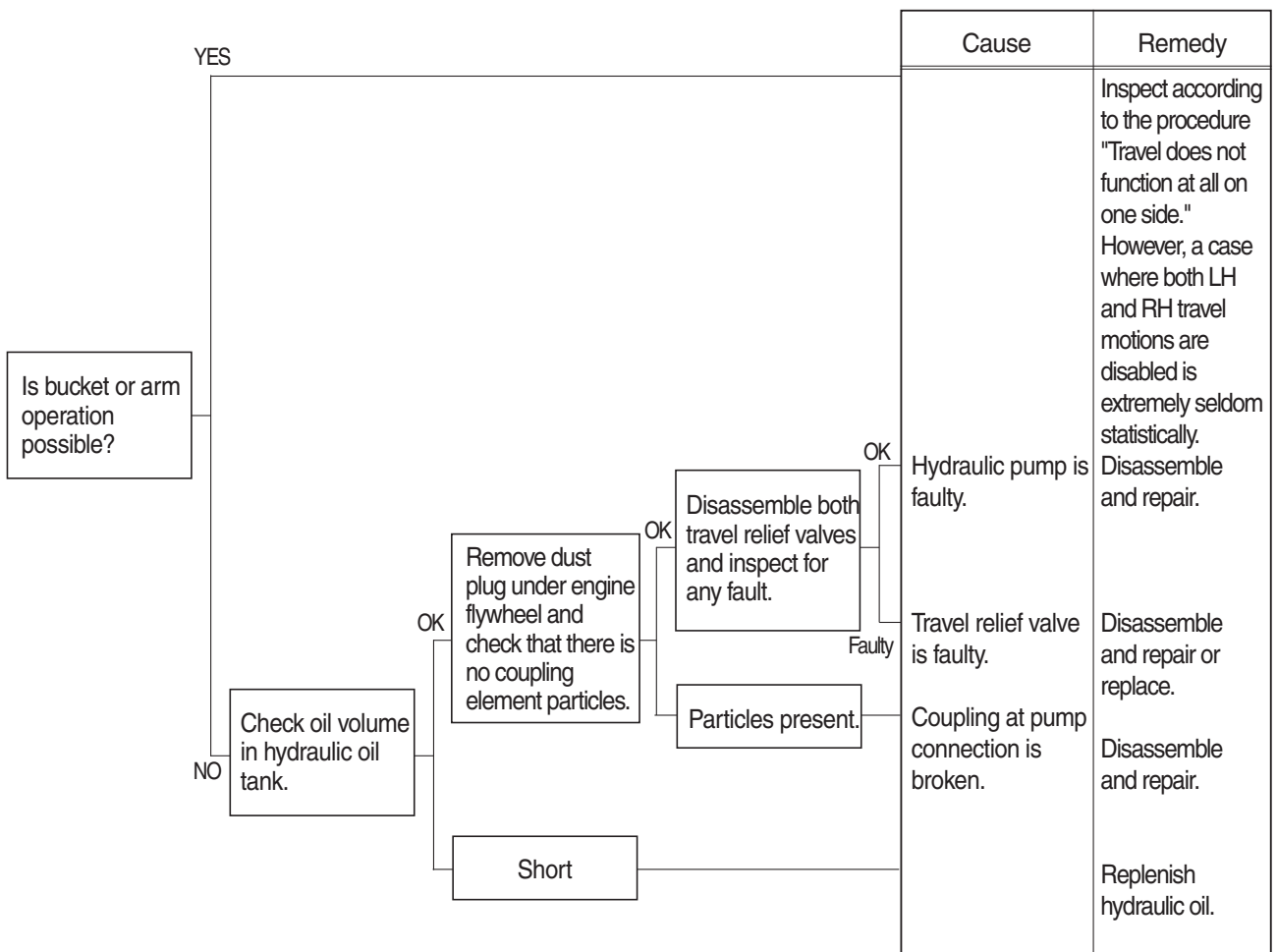

5) TRAVEL ACTION IS POWERLESS (travel only)

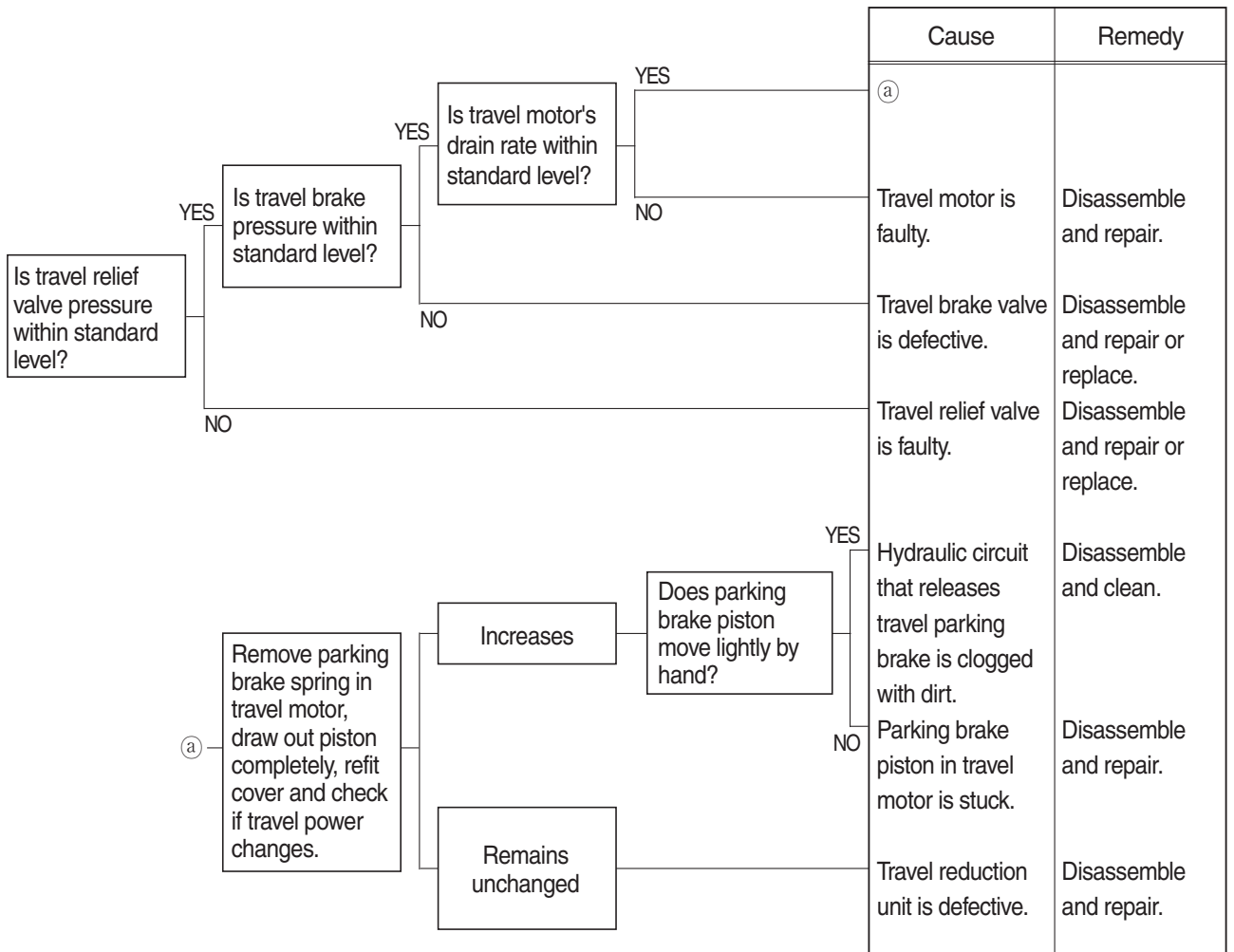

6) MACHINE RUNS RECKLESSLY ON A SLOPE



7) MACHINE MAKES A CURVED TRAVEL OR DOES NOT TRAVEL AT ALL WHEN TRAVEL AND ATTACHMENT OPERATIONS ARE EXECUTED AT THE SAME TIME

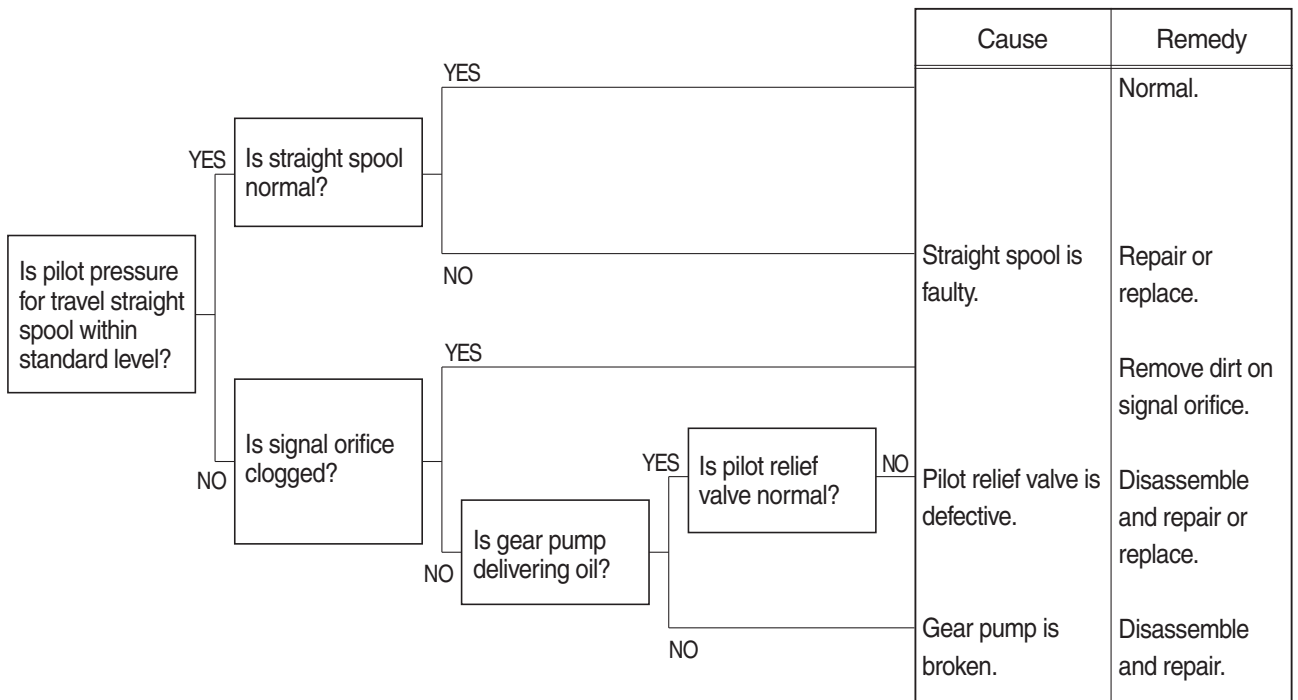

6. ATTACHMENT SYSTEM

1) BOOM OR ARM ACTION IS IMPOSSIBLE AT ALL

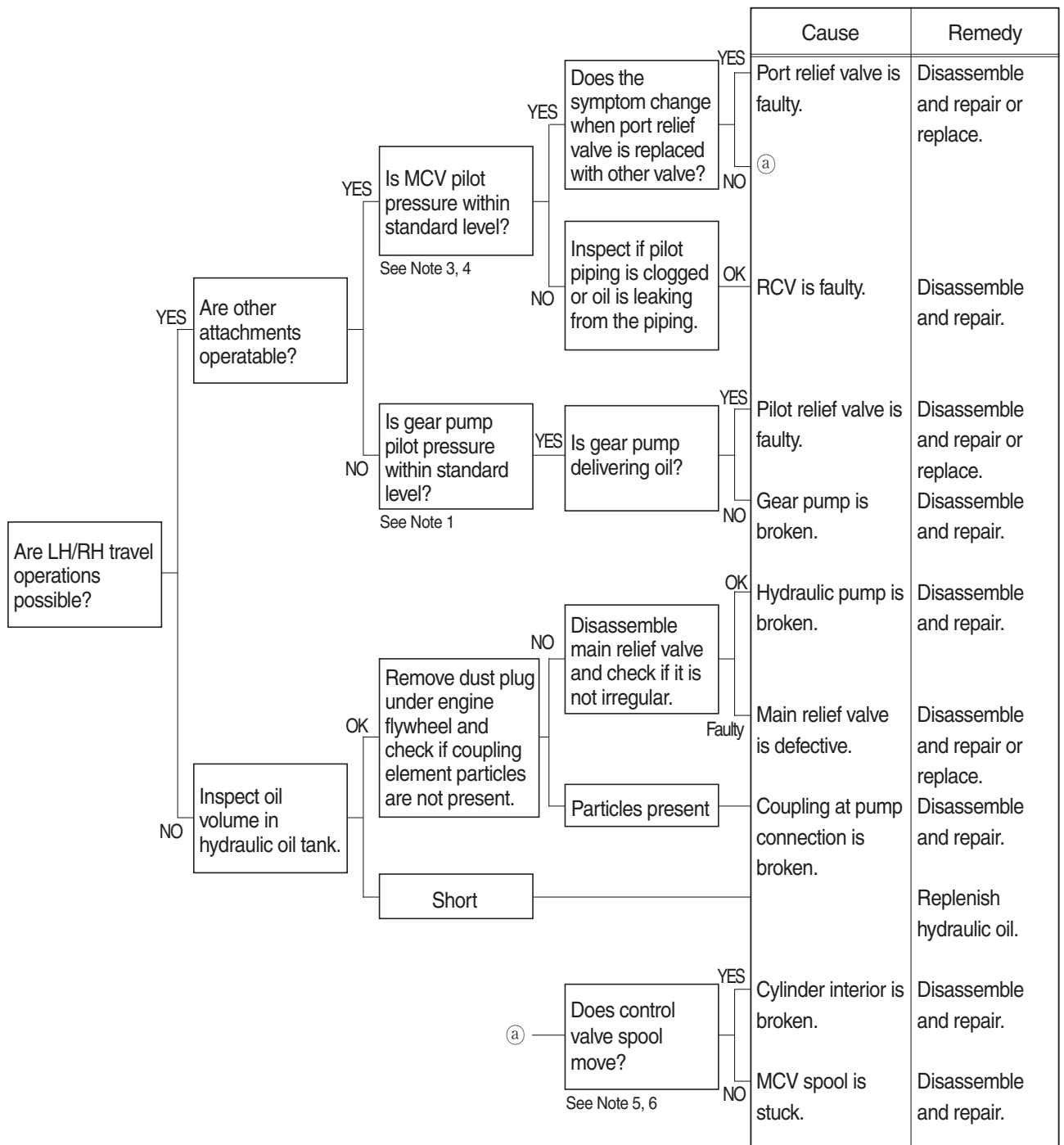

2) BOOM, ARM OR BUCKET SPEED IS LOW

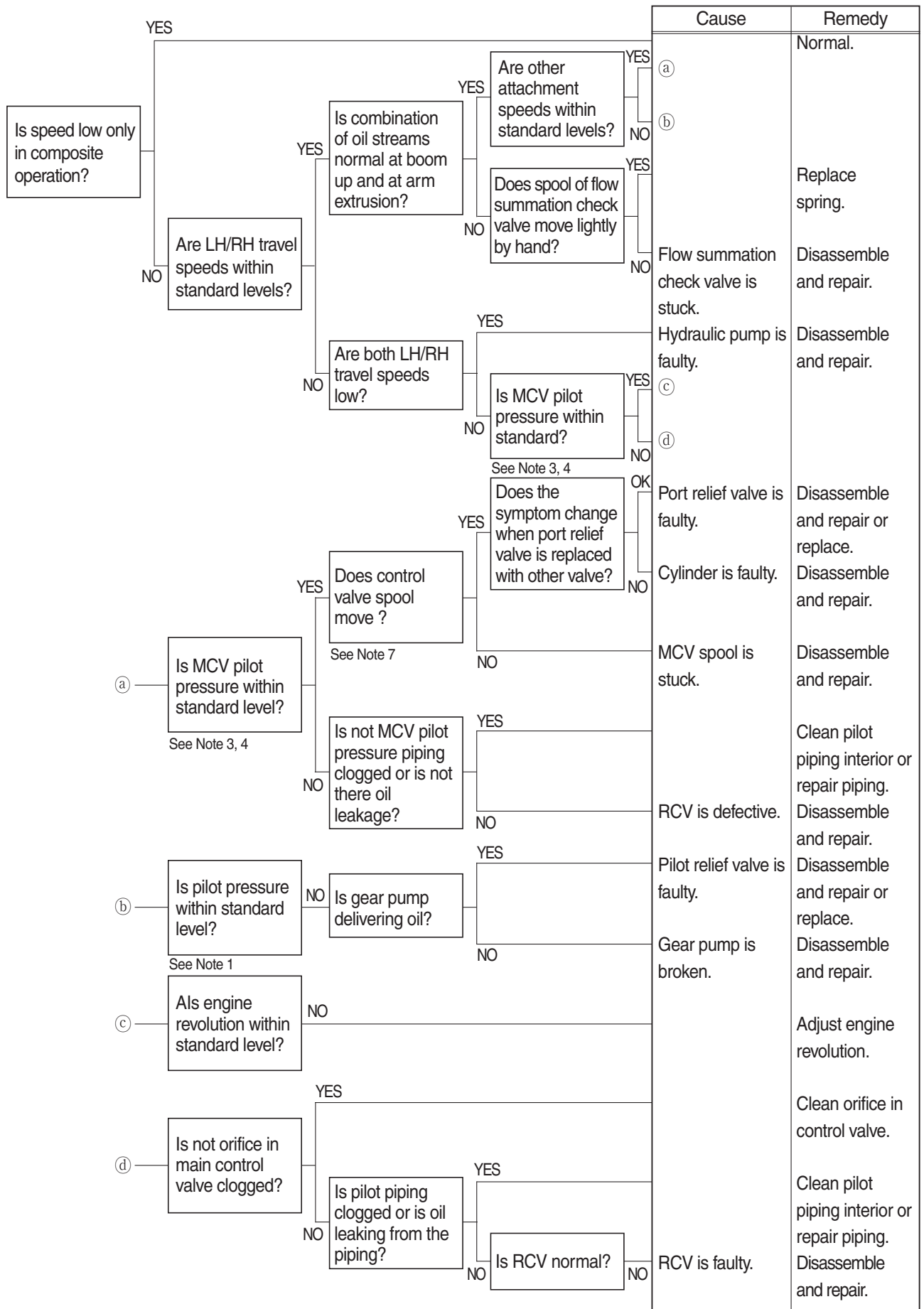

3) BOOM, ARM OR BUCKET CYLINDER EXTENDS OR CONTRACTS ITSELF AND ATTACHMENT FALLS

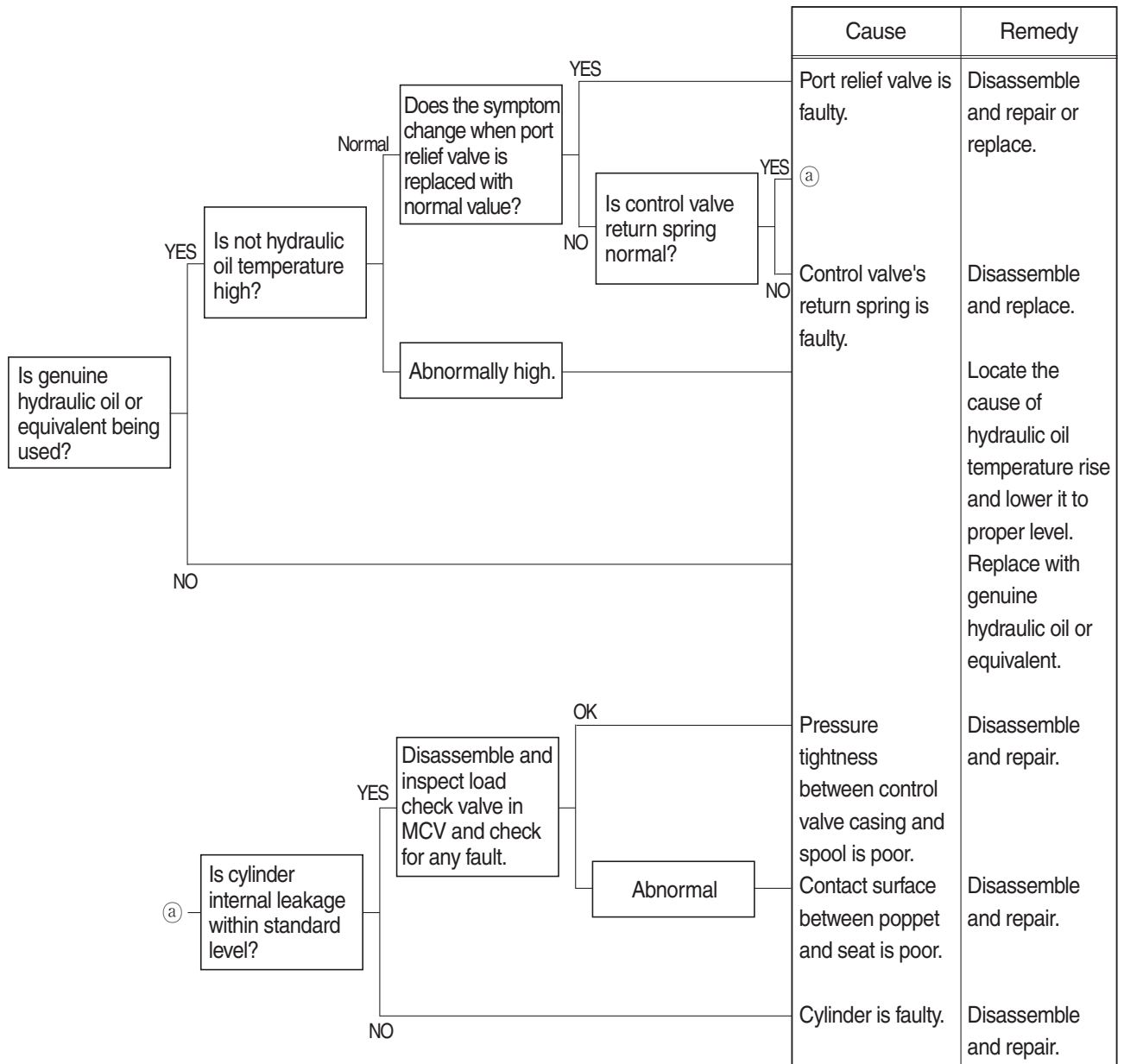

4) BOOM, ARM OR BUCKET POWER IS WEAK

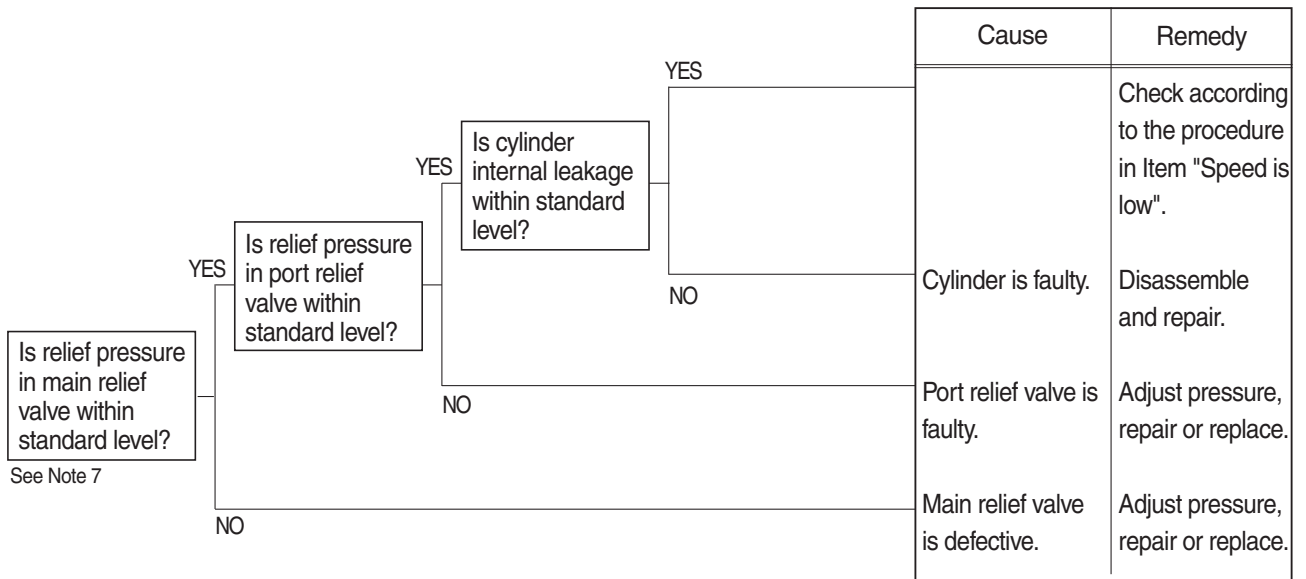

5) ONLY BUCKET OPERATION IS TOTALLY IMPOSSIBLE

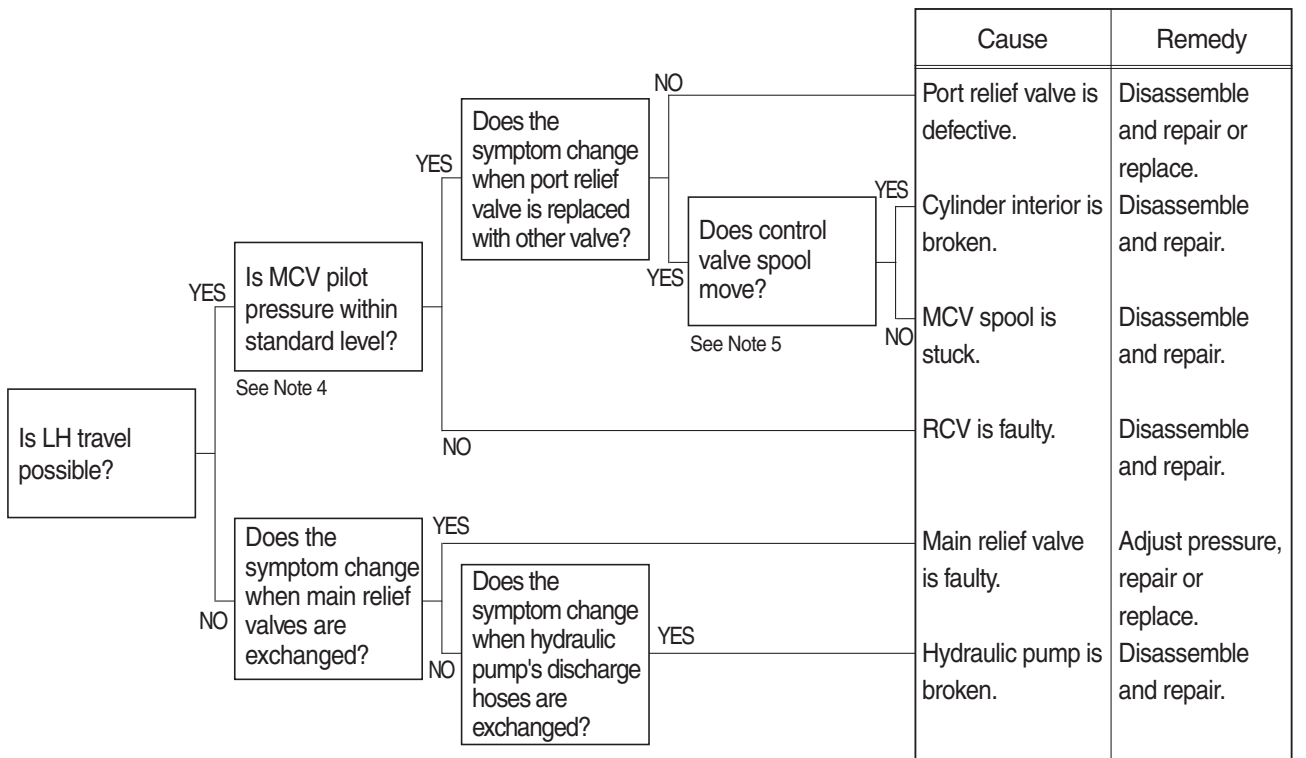

6) BOOM MAKES A SQUEAKING NOISE WHEN BOOM IS OPERATED

| | | Cause | Remedy |
|--|-----|--------------------------------------|--|
| <div style="border: 1px solid black; padding: 5px; width: fit-content;"> Is boom foot pin greased sufficiently? </div> | YES | | Frictional noise occurs between the sliding faces of boom cylinder's oil seal and boom proper. ※ Frictional noise will disappear if they are kept used. |
| | NO | Boom foot pin has run out of grease. | Supply grease to it. ※ If seizure is in an initial stage, supply sufficient grease. If seizure is in a grown state, correct it by paper lapping or with an oil stone. |

※ HOW TO CHECK INTERNAL BOOM CYLINDER LEAKAGE

1. Lower the bucket teeth to the ground with bucket cylinder fully retracted and arm cylinder rod retracted almost in full.

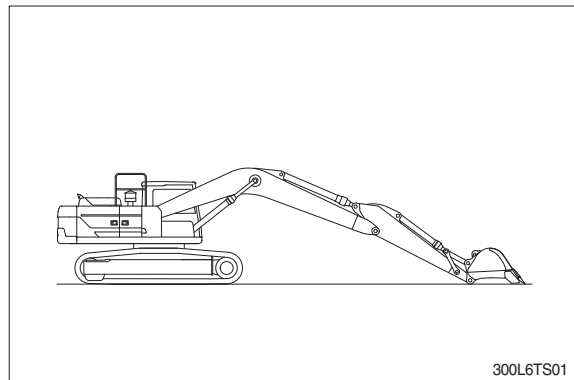

2. Disconnect hose (A) from rod side of boom cylinder and drain oil from cylinders and hose. (put cups on piping and hose ends)

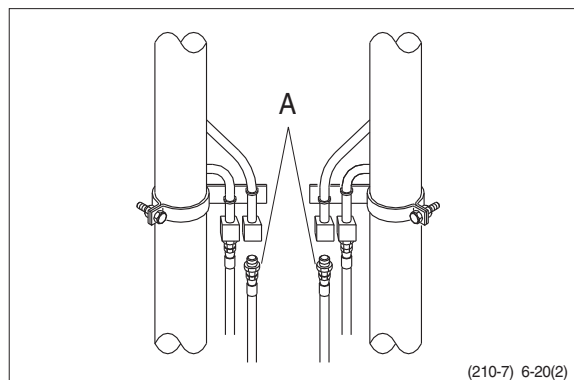

3. Raise bucket OFF the ground by retracting the arm cylinder rod.

If oil leaks from piping side and boom cylinder rod is retracted there is an internal leak in the cylinder.

If no oil leaks from piping side and boom cylinder rod is retracted, there is an internal leak in the control valve.

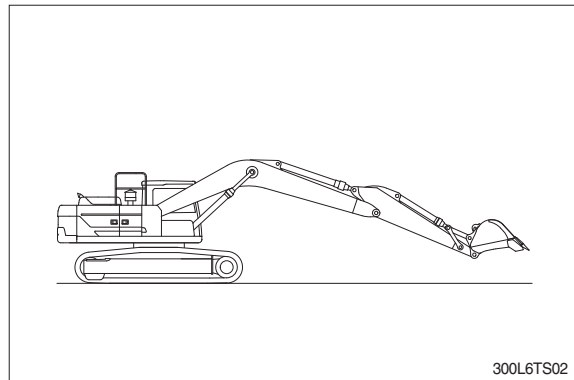

GROUP 3 ELECTRICAL SYSTEM

1. WHEN STARTING SWITCH IS TURNED ON, MONITOR PANEL DISPLAY DOES NOT APPEAR

- Before disconnecting the connector, always turn the starting switch OFF.
- Before carrying out below procedure, check all the related connectors are properly inserted and short of fuse No. 8, 14.
- After checking, insert the disconnected connectors again immediately unless otherwise specified.

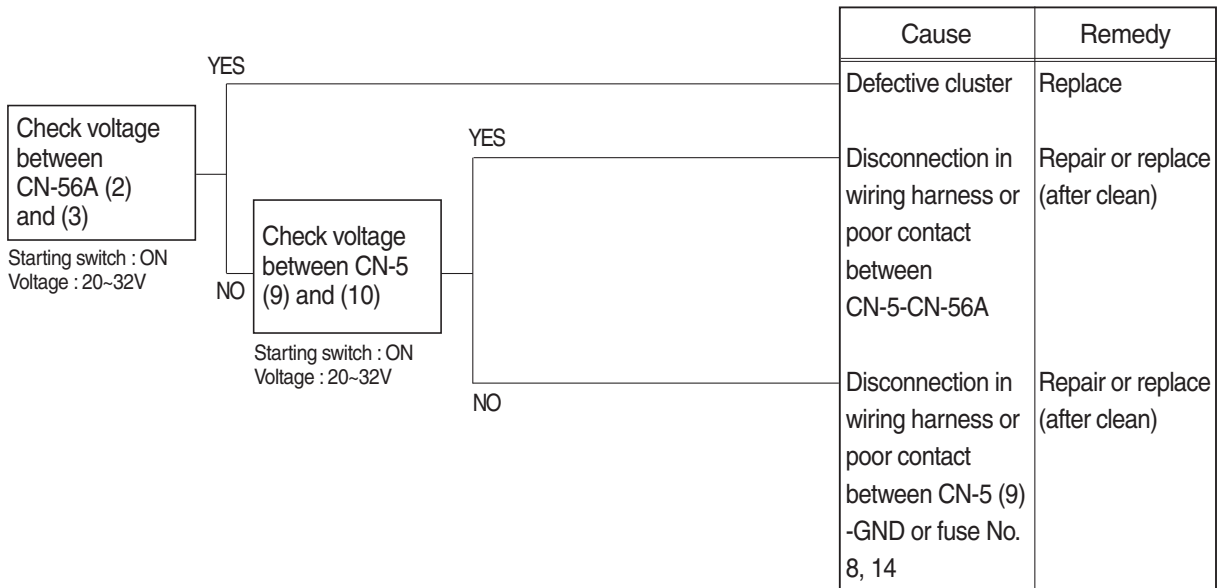

Check voltage

| | |
|-----|--------|
| YES | 20~32V |
| NO | 0V |

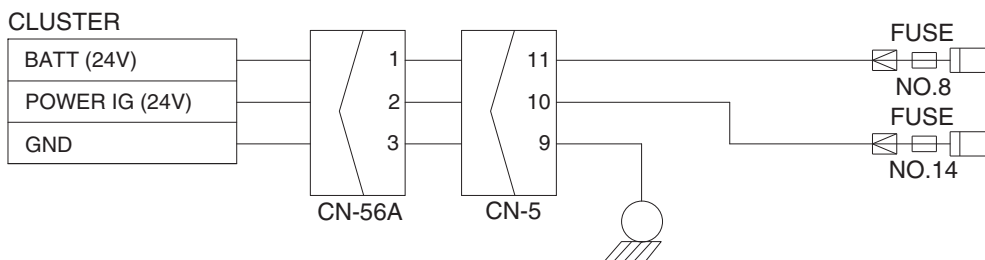

380L6ES01

2. COMMUNICATION ERROR FLASHES ON THE CLUSTER (HCESPN 840, FMI 2)

- Before disconnecting the connector, always turn the starting switch OFF.
- Before carrying out below procedure, check all the related connectors are properly inserted.
- After checking, insert the disconnected connectors again immediately unless otherwise specified.

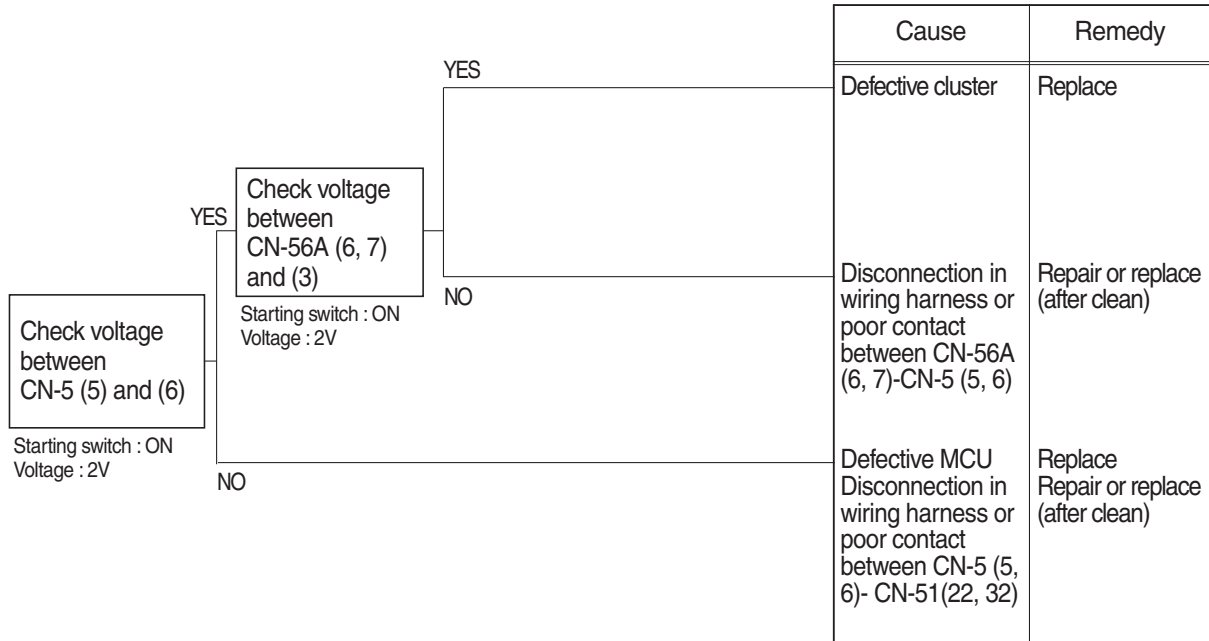

Check voltage

| | |
|-----|----|
| YES | 2V |
| NO | 0V |

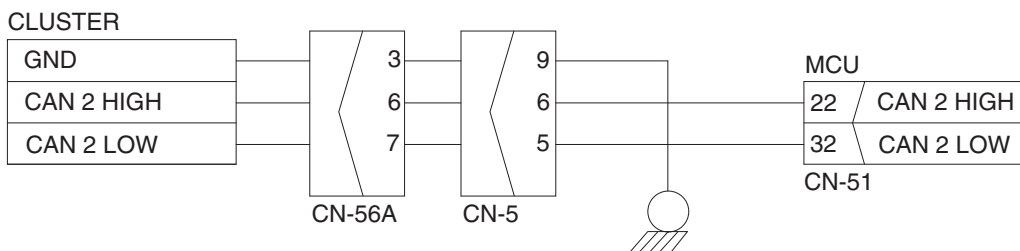

300L6ES02

3. BATTERY CHARGING WARNING LAMP LIGHTS UP (Starting switch : ON)

- Before disconnecting the connector, always turn the starting switch OFF.
- Before carrying out below procedure, check all the related connectors are properly inserted.
- After checking, insert the disconnected connectors again immediately unless otherwise specified.

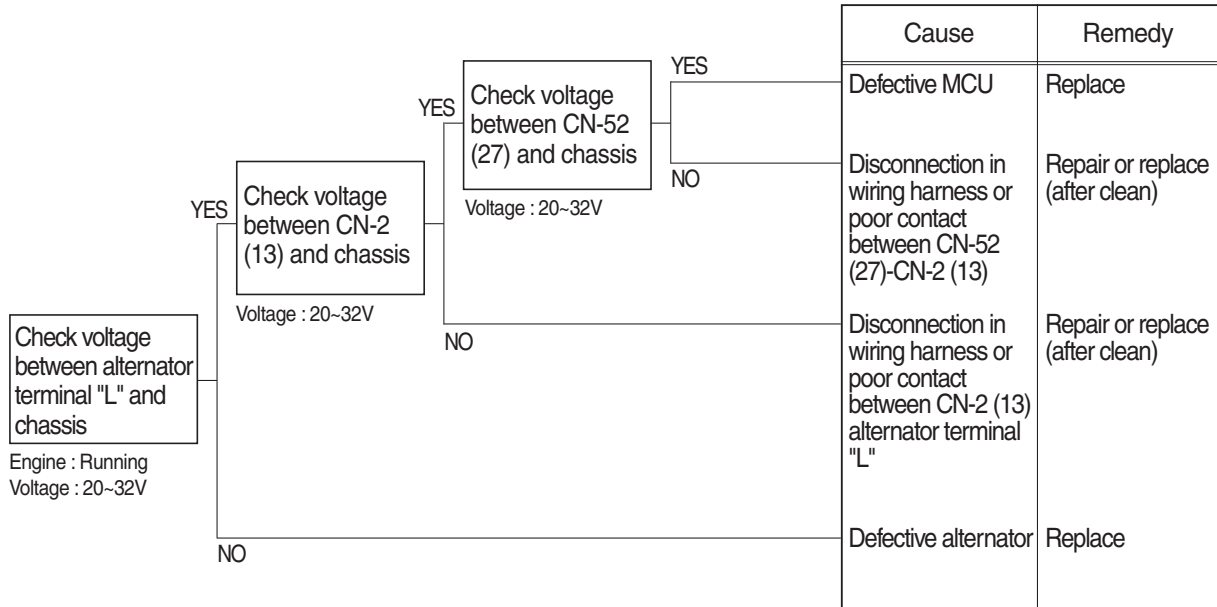

Check voltage

| | |
|-----|--------|
| YES | 20~32V |
| NO | 0V |

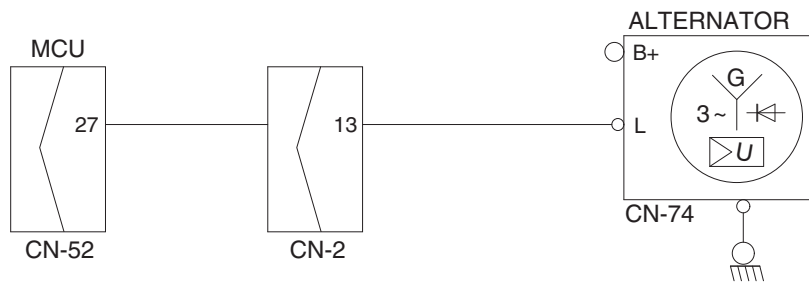

300L6ES03

4. WHEN COOLANT OVERHEAT WARNING LAMP LIGHTS UP (engine is started)

- Before disconnecting the connector, always turn the starting switch OFF.
- Before carrying out below procedure, check all the related connectors are properly inserted.
- After checking, insert the disconnected connectors again immediately unless otherwise specified.

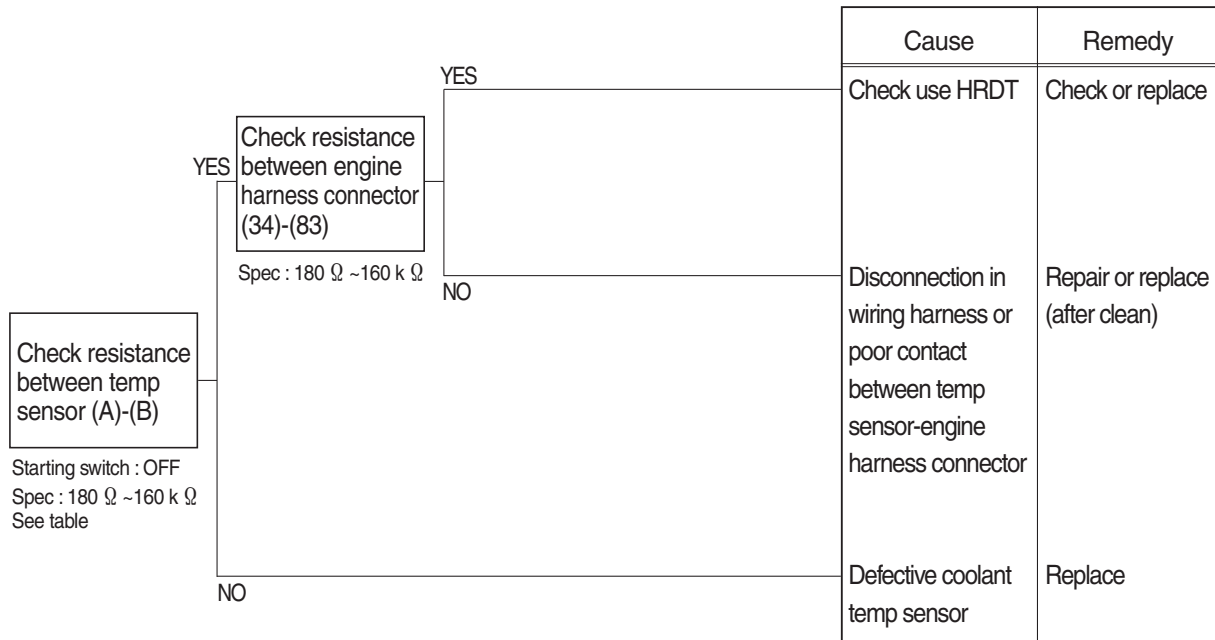

Check Table

| Temperature (°C) | 0 | 25 | 50 | 80 | 95 |
|------------------|-------|----------|---------|---------|---------|
| Resistance (k Ω) | 30~37 | 9.3~10.7 | 3.2~3.8 | 1.0~1.3 | 0.7~0.8 |

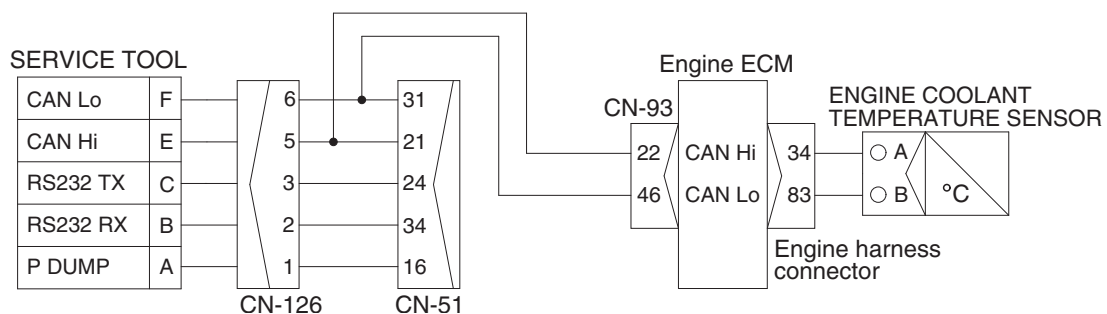

300L6ES04

5.  **WHEN AIR CLEANER WARNING LAMP LIGHTS UP (engine is started)**

- Before disconnecting the connector, always turn the starting switch OFF.
- Before carrying out below procedure, check all the related connectors are properly inserted.
- After checking, insert the disconnected connectors again immediately unless otherwise specified.

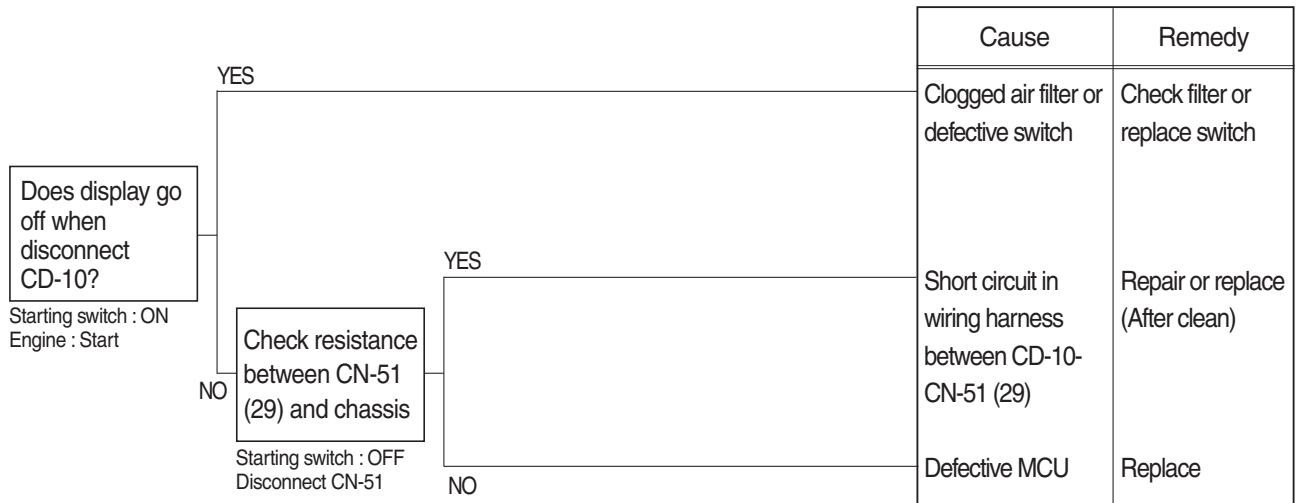

Check resistance

| | |
|-----|---------|
| YES | MAX 1Ω |
| NO | MIN 1MΩ |

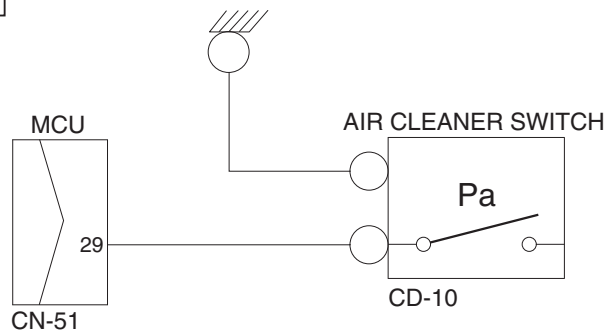

300L6ES06

6. WHEN ENGINE OIL PRESSURE WARNING LAMP LIGHTS UP (engine is started)

- Before disconnecting the connector, always turn the starting switch OFF.
- Before carrying out below procedure, check all the related connectors are properly inserted.
- After checking, insert the disconnected connectors again immediately unless otherwise specified.

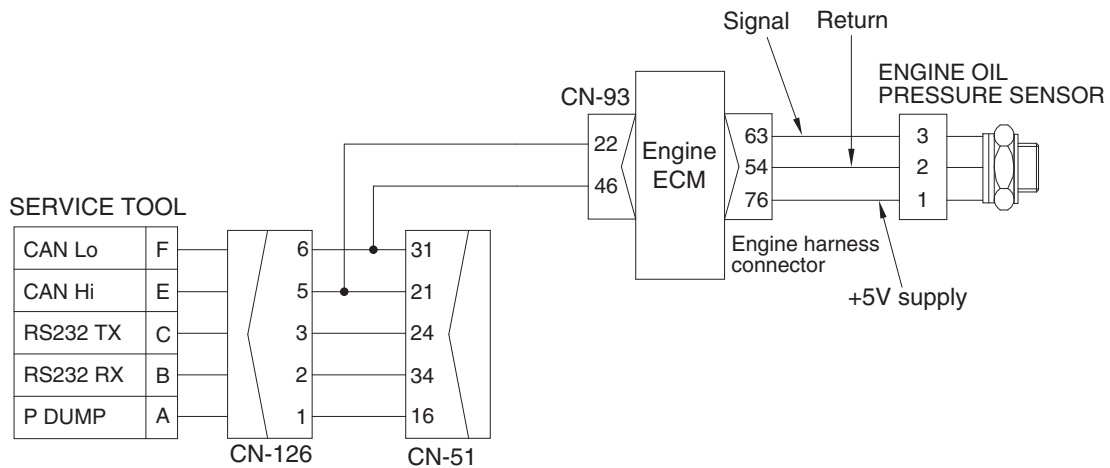
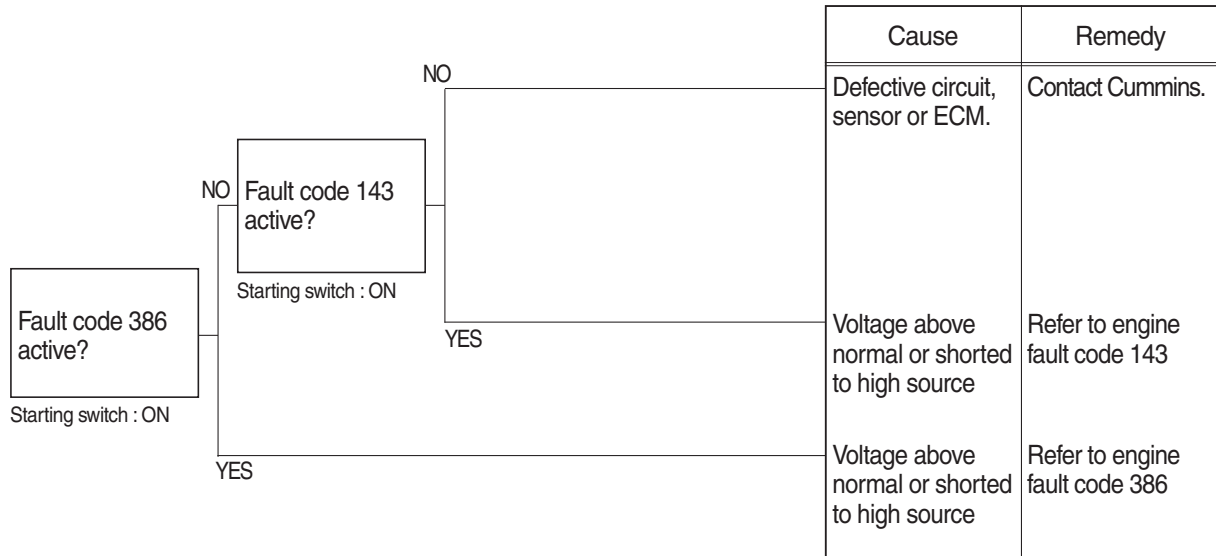

300L6ES07

7. WHEN HYDRAULIC OIL TEMPERATURE WARNING LAMP LIGHTS UP (engine is started)

- Before disconnecting the connector, always turn the starting switch OFF.
- Before carrying out below procedure, check all the related connectors are properly inserted.
- After checking, insert the disconnected connectors again immediately unless otherwise specified.

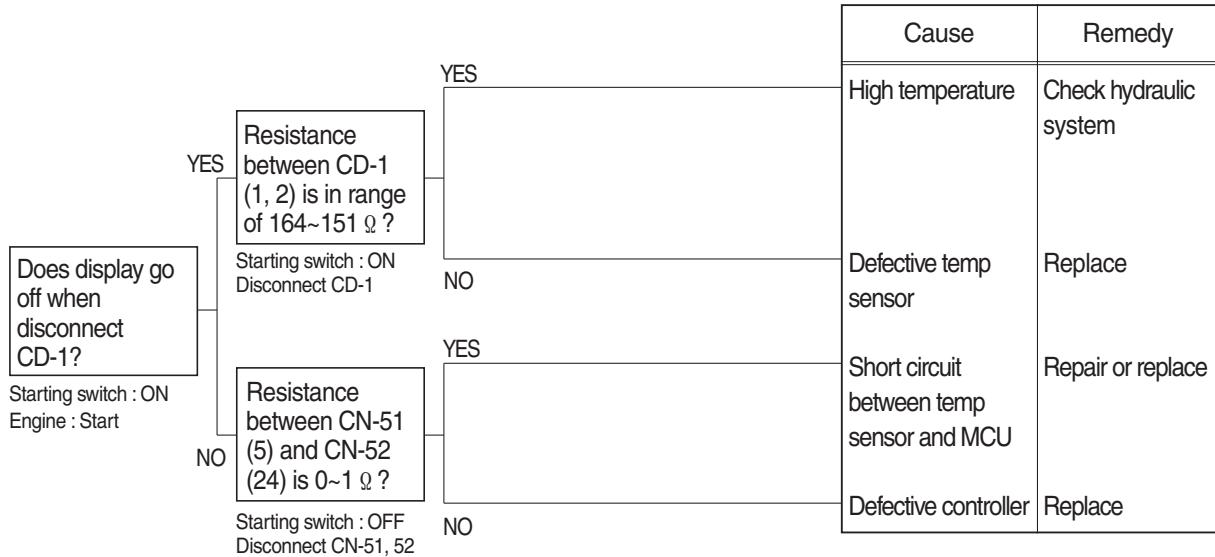

Check Table

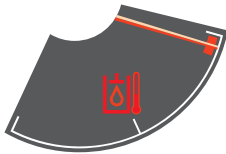

| Temperature (°C) | ~ -30 | ~ -10 | ~ 0 | ~ 40 | ~ 70 | ~ 80 | ~ 90 | ~ 100 | 105~ |
|------------------|-----------------|----------------|---------------|---------------|----------------|-----------------|-----------------|-----------------|----------------|
| Resistance (k Ω) | 22.22 ~31.78 | 8.16 ~10.74 | 5.18 ~ 6.6 | 1.06 ~1.28 | 0.39 ~0.476 | 0.322 ~0.298 | 0.243 ~0.219 | 0.185 ~0.167 | 0.164 0.151 |

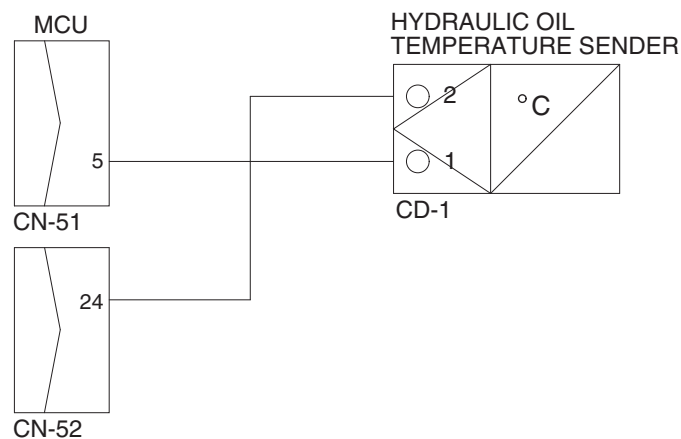

300L6ES08

8. WHEN COOLANT TEMPERATURE GAUGE DOES NOT OPERATE

- Before disconnecting the connector, always turn the starting switch OFF.
- Before carrying out below procedure, check all the related connectors are properly inserted.
- After checking, insert the disconnected connectors again immediately unless otherwise specified.

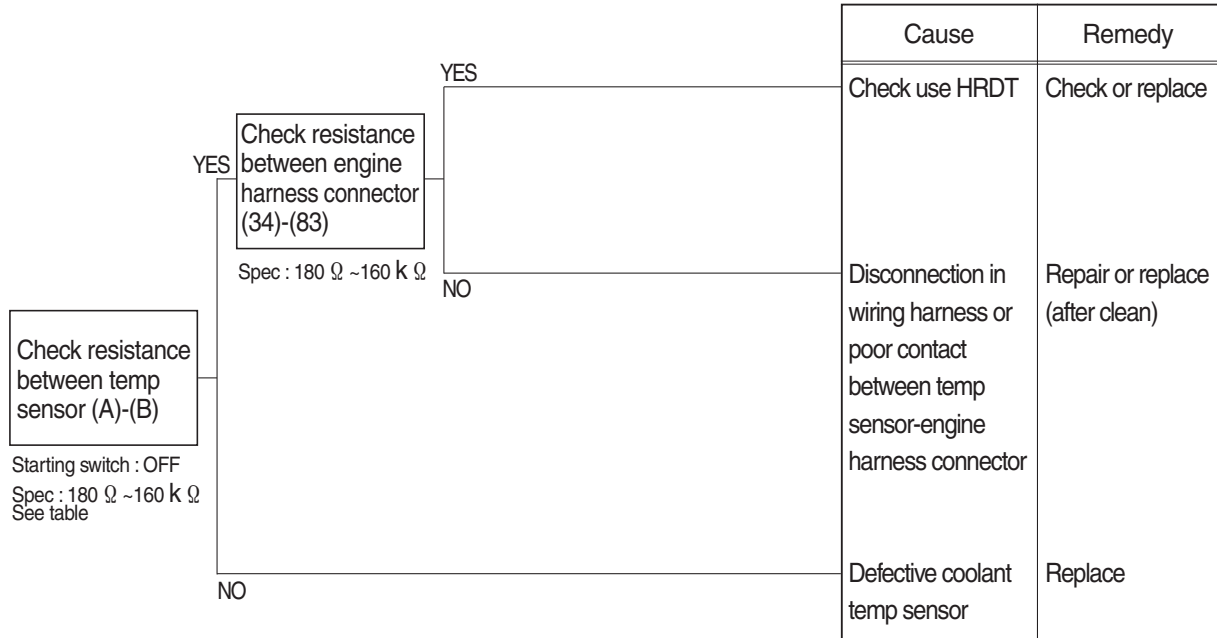

Check Table

| Temperature (°C) | 0 | 25 | 50 | 80 | 95 |
|------------------|-------|----------|---------|---------|---------|
| Resistance (k Ω) | 30~37 | 9.3~10.7 | 3.2~3.8 | 1.0~1.3 | 0.7~0.8 |

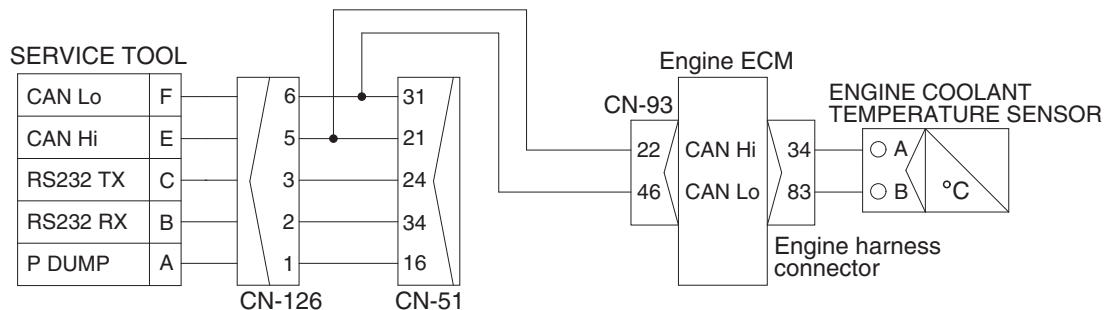

300L6ES04

9. WHEN FUEL GAUGE DOES NOT OPERATE (HCESPN 301, FMI 3 or 4)

- Before disconnecting the connector, always turn the starting switch OFF.
- Before carrying out below procedure, check all the related connectors are properly inserted.
- After checking, insert the disconnected connectors again immediately unless otherwise specified.

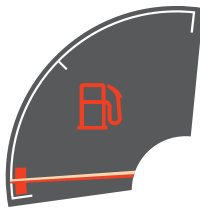
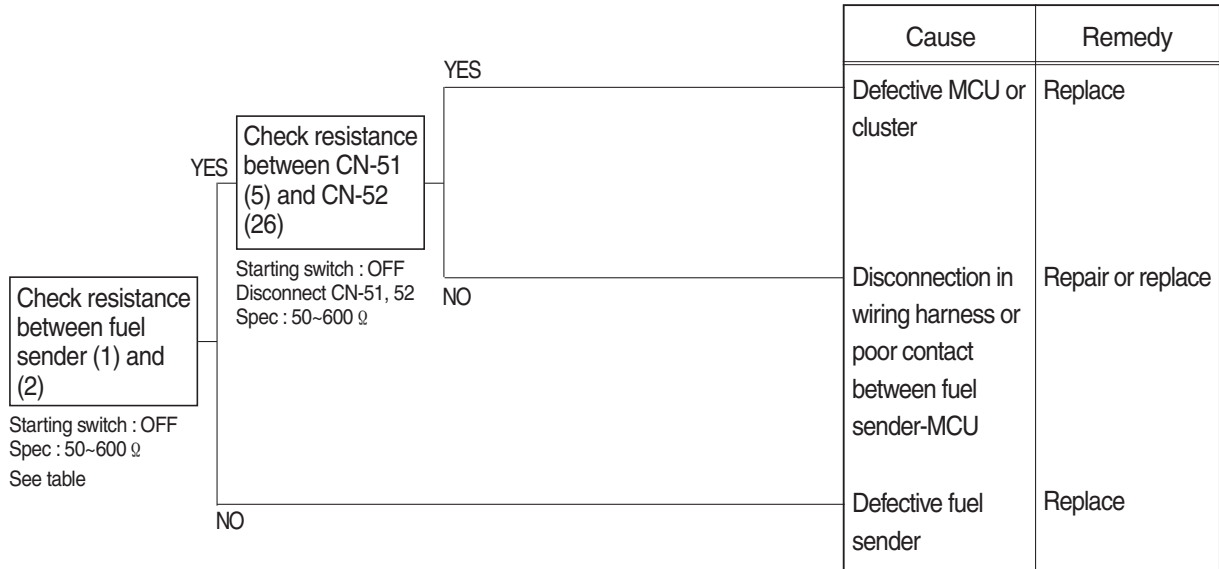

Check Table

| Range | Resistance (Ω) | Range | Resistance (Ω) |
|-------|------------------|---------------|------------------|
| Full | 50 | 5/12 | 400 |
| 11/12 | 100 | 4/12 | 450 |
| 10/12 | 150 | 3/12 | 500 |
| 9/12 | 200 | 2/12 | 550 |
| 8/12 | 250 | 1/12 | 600 |
| 7/12 | 300 | Empty warning | 700 |
| 6/12 | 350 | - | - |

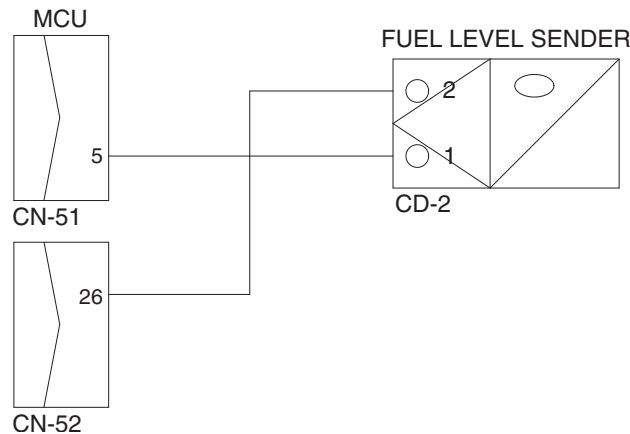

300L6ES10

10. WHEN SAFETY SOLENOID DOES NOT OPERATE

- Before disconnecting the connector, always turn the starting switch OFF.
- Before carrying out below procedure, check all the related connectors are properly inserted and short of fuse No. 24.
- After checking, insert the disconnected connectors again immediately unless otherwise specified.

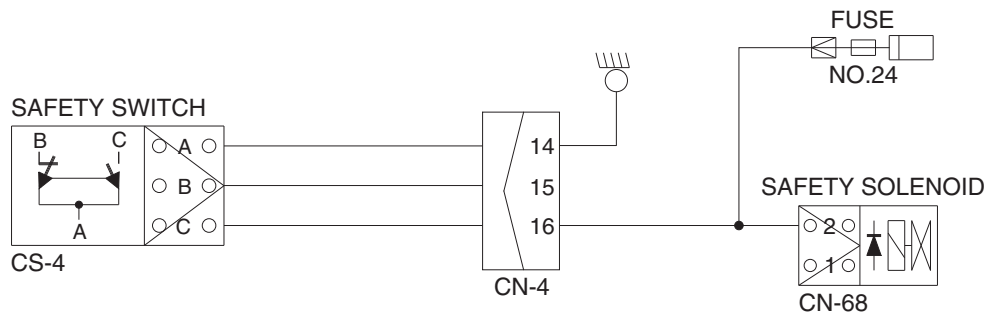
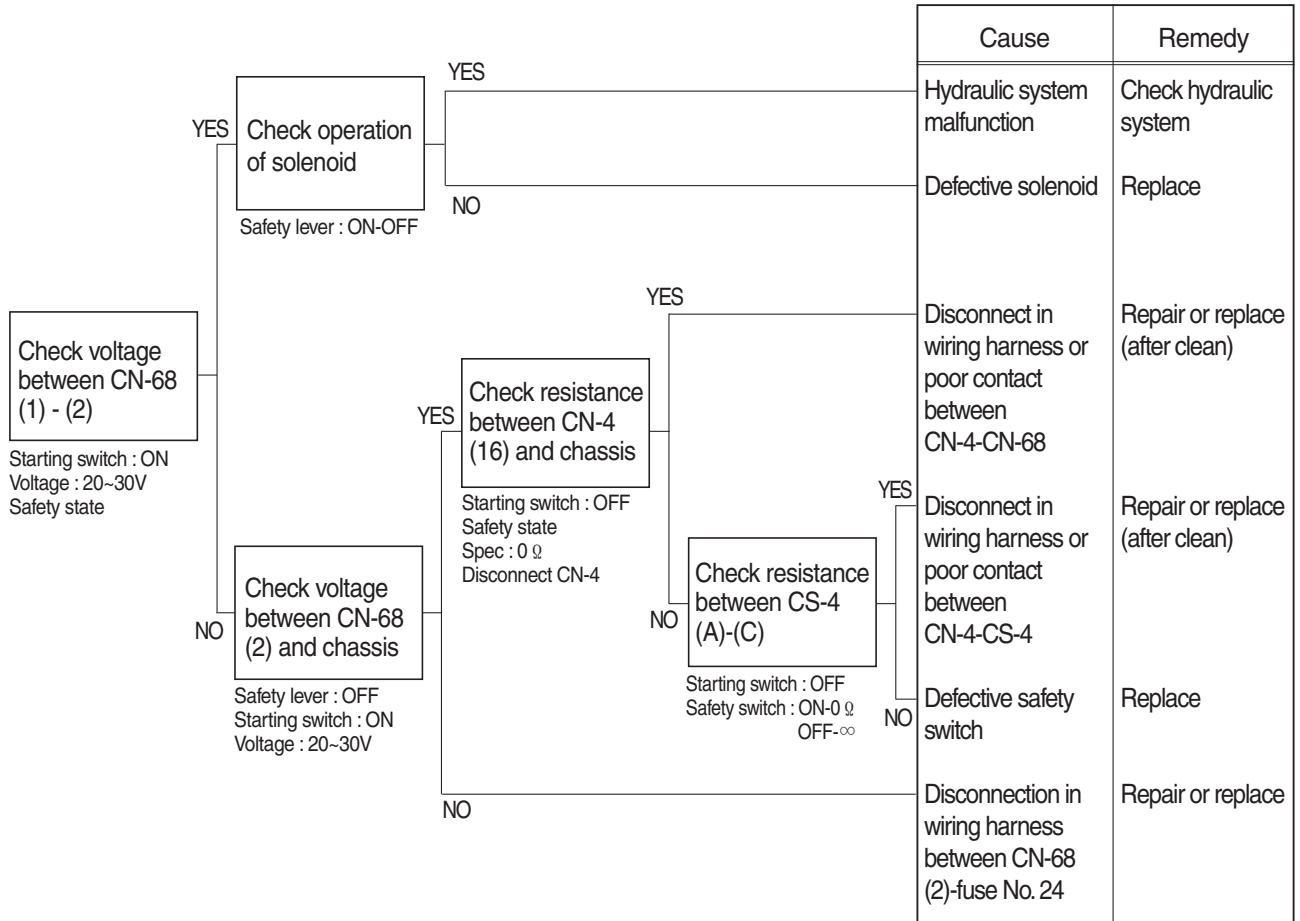

380L6ES02

11. WHEN TRAVEL SPEED 1, 2 DOES NOT OPERATE (HCESPN 167, FMI 4 or 6)

- Before disconnecting the connector, always turn the starting switch OFF.
- Before carrying out below procedure, check all the related connectors are properly inserted and short of fuse No. 26.
- After checking, insert the disconnected connectors again immediately unless otherwise specified.

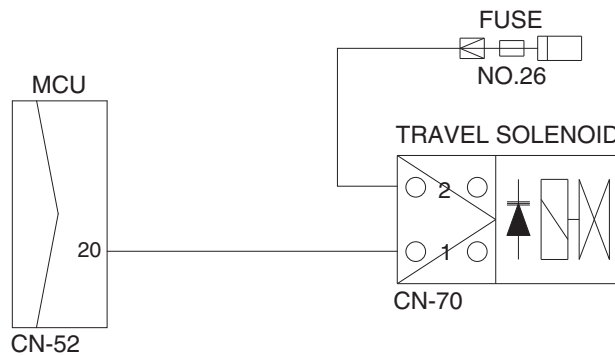
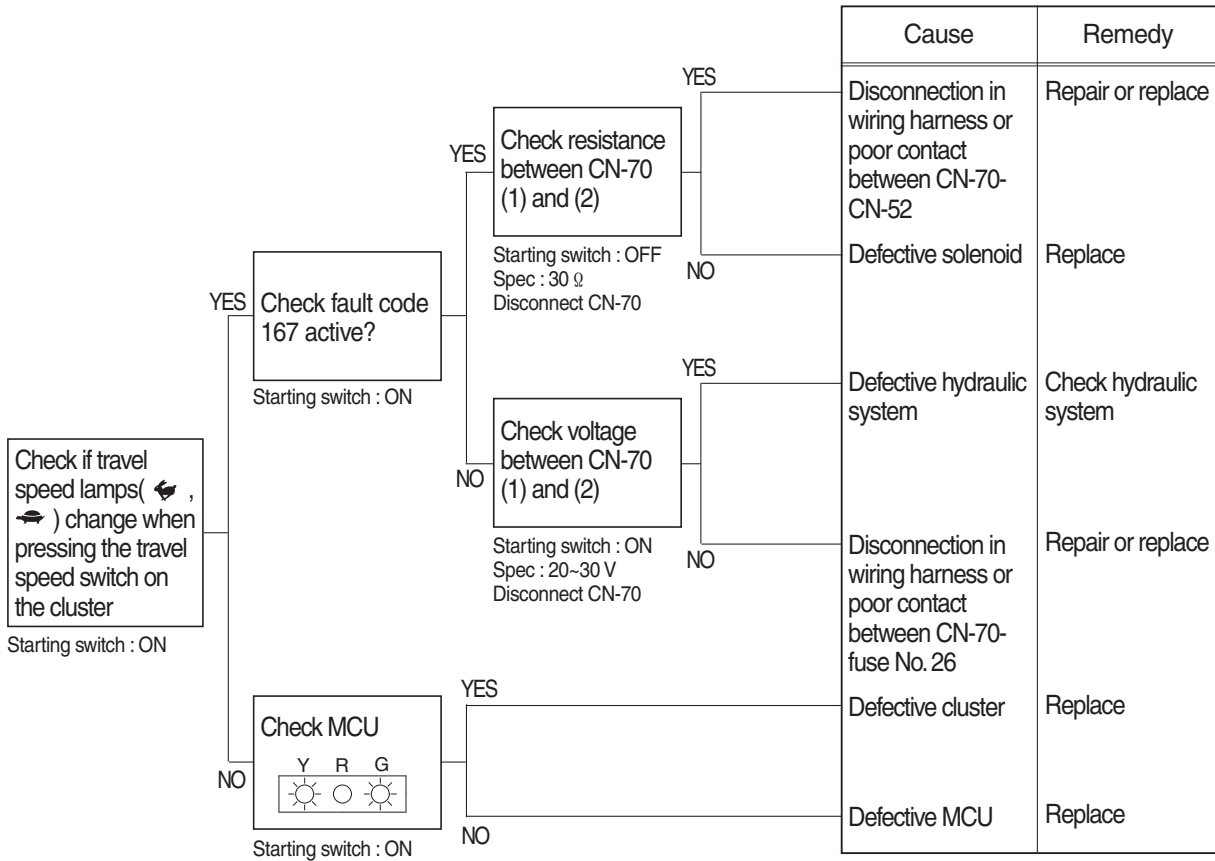

380L6ES03

12. WHEN ENGINE DOES NOT START (lights up condition)

- Before disconnecting the connector, always turn the starting switch OFF.
- Before carrying out below procedure, check all the related connectors are properly inserted and short of fuse No. 1, 5, 9, 21.
- After checking, insert the disconnected connectors again immediately unless otherwise specified.

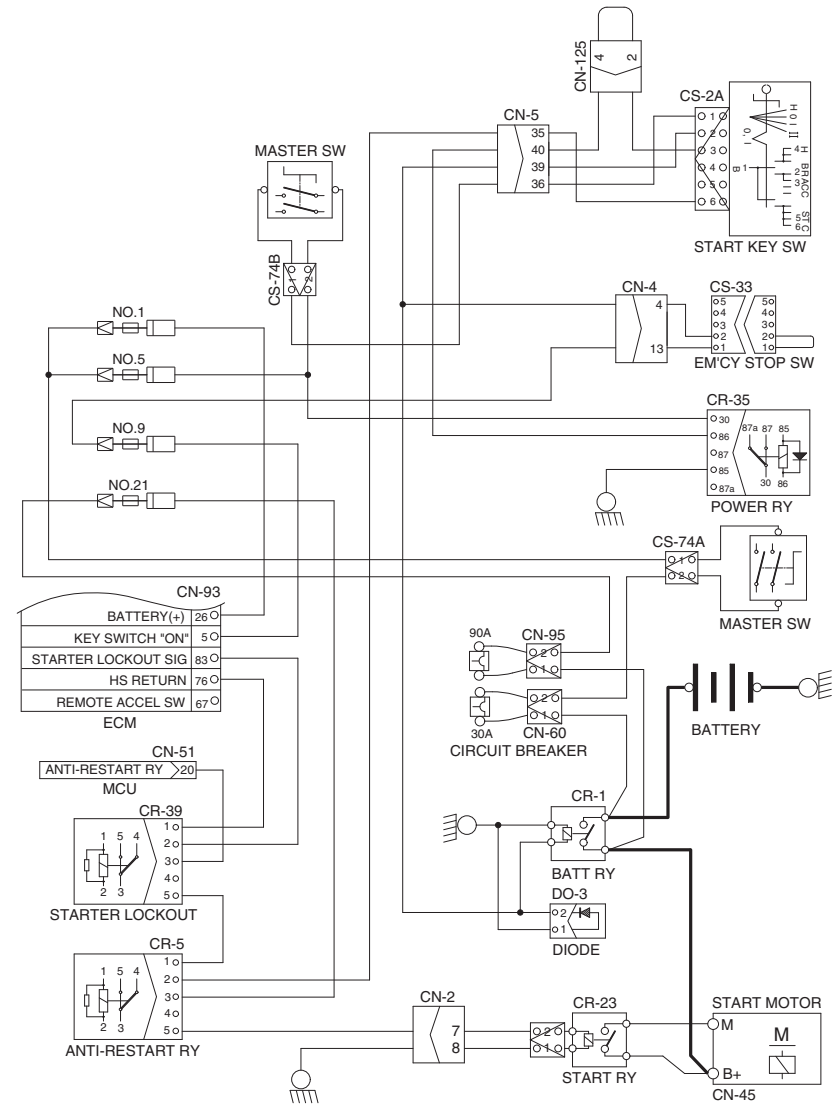
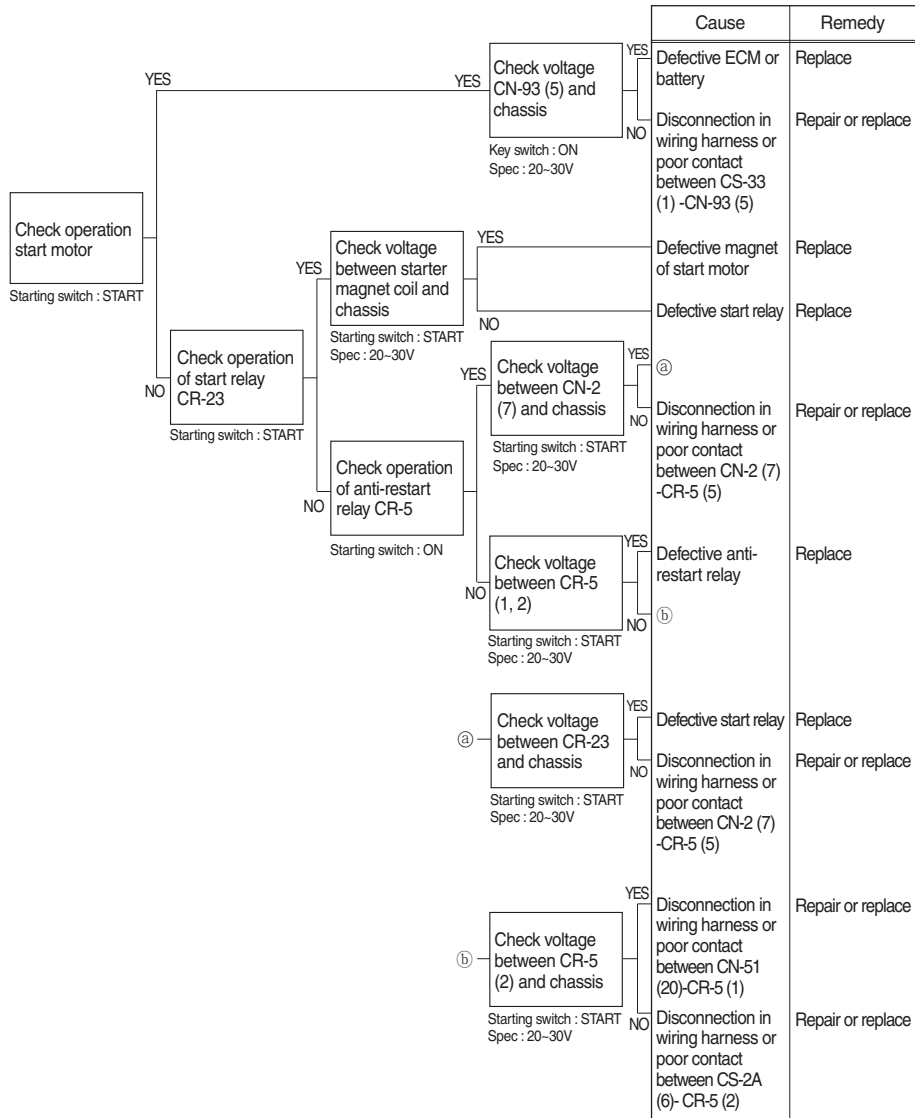

13. WHEN STARTING SWITCH ON DOES NOT OPERATE

- Before disconnecting the connector, always turn the starting switch OFF.
- Before carrying out below procedure, check all the related connectors are properly inserted, master switch ON and check open circuit of circuit breaker (CN-60).
- After checking, insert the disconnected connectors again immediately unless otherwise specified.

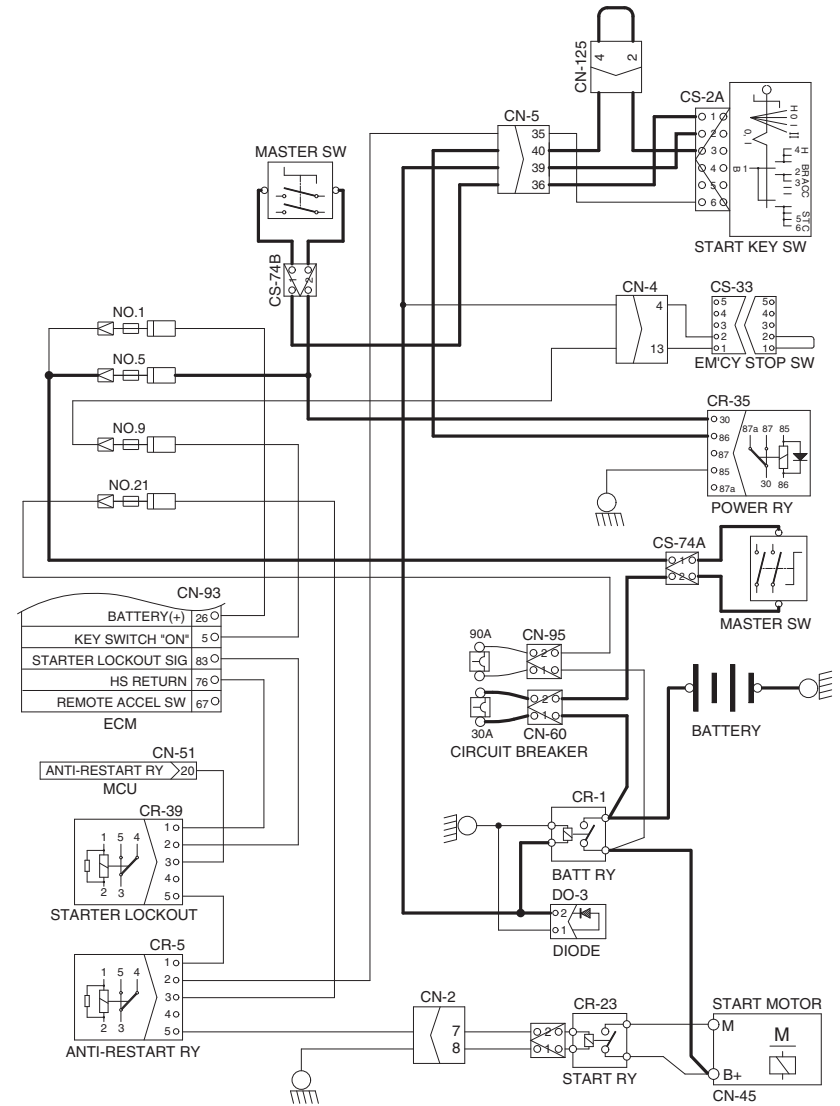
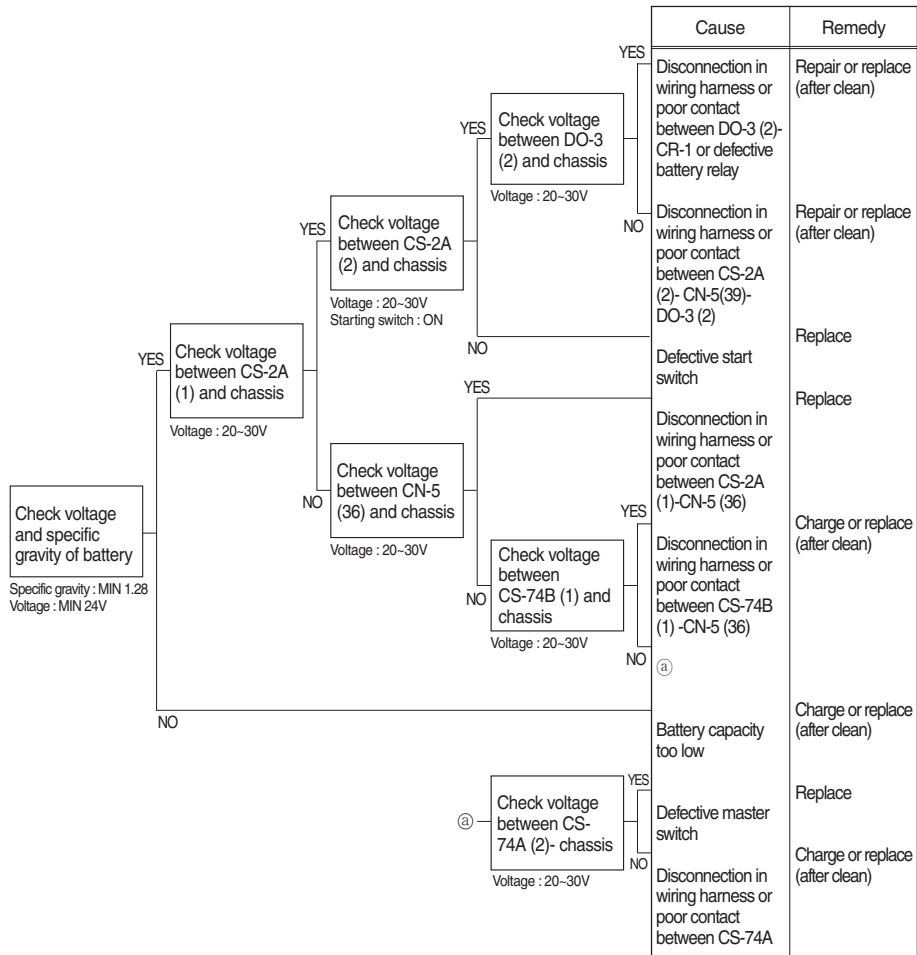

14. WHEN STARTING SWITCH IS TURNED ON, WIPER MOTOR DOES NOT OPERATE

- Before disconnecting the connector, always turn the starting switch OFF.
- Before carrying out below procedure, check all the related connectors are properly inserted and the fuse No. 7, 12 and 18 are not blown out.
- After checking, insert the disconnected connectors again immediately unless otherwise specified.

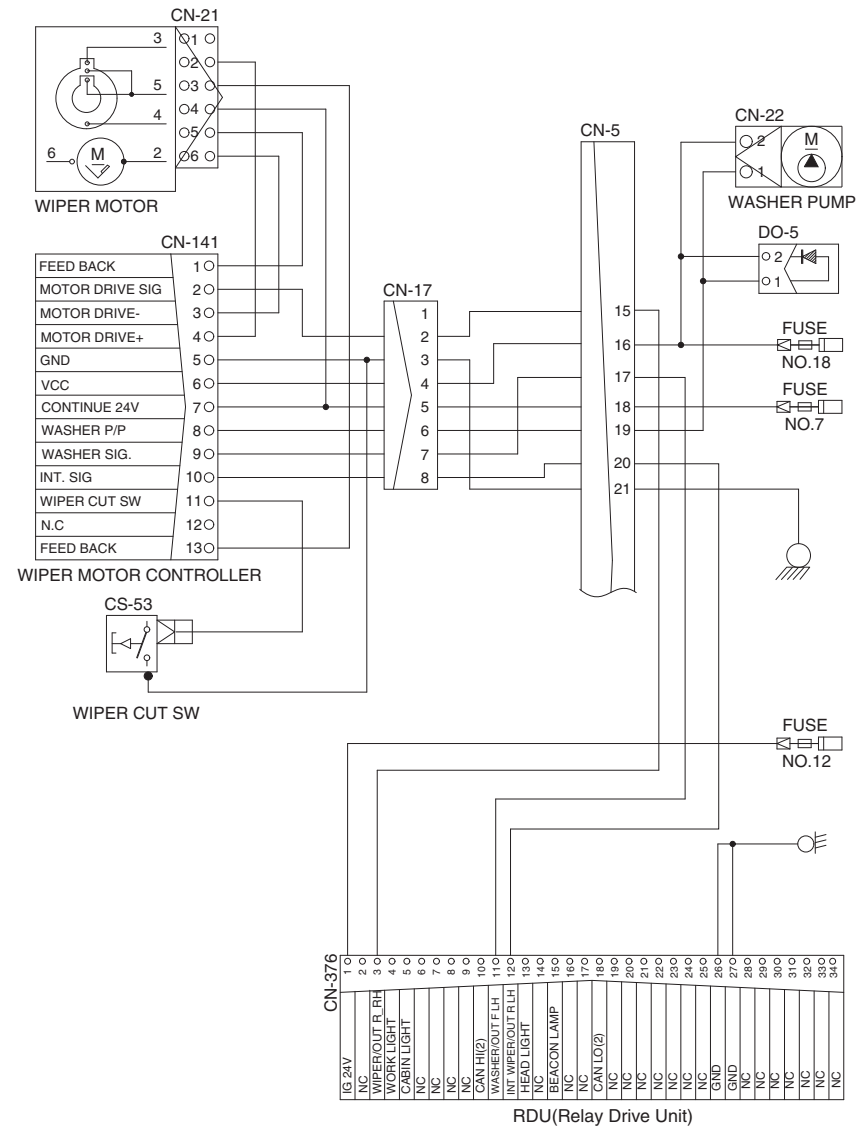
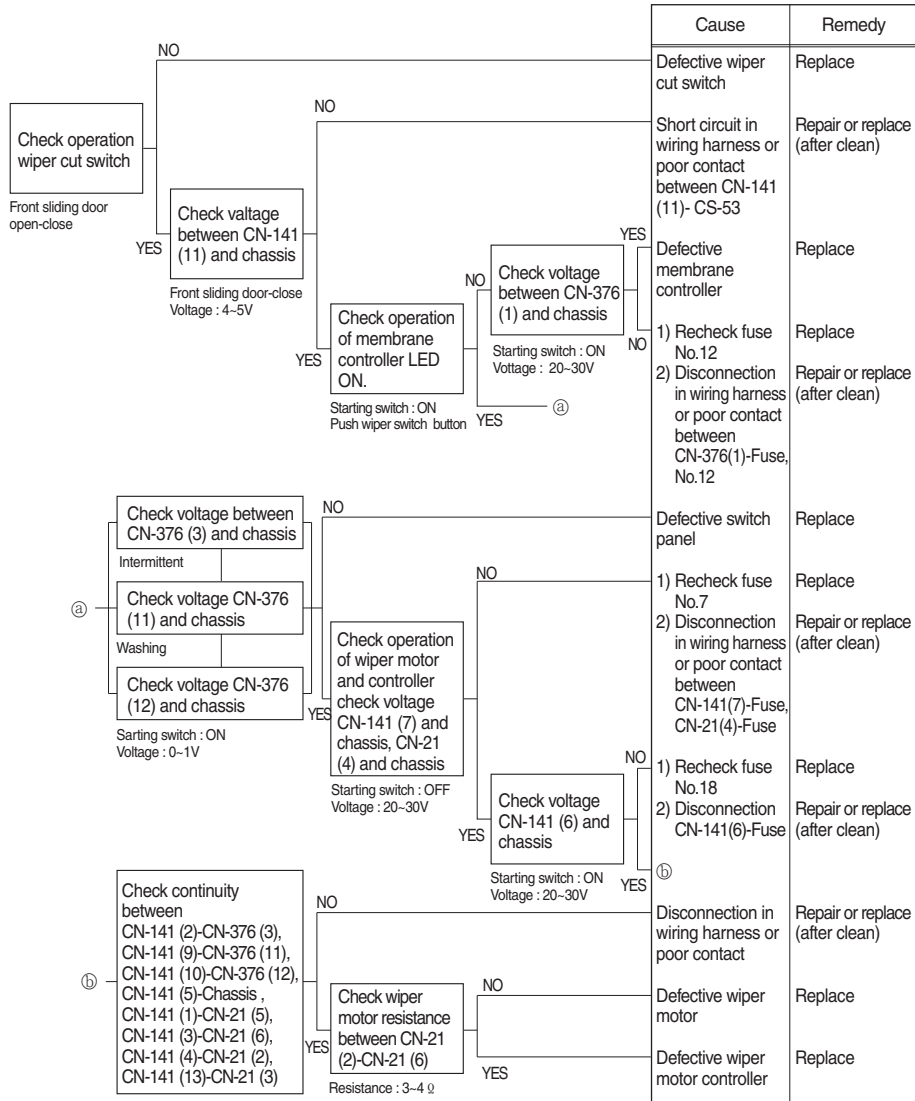

15. WHEN STARTING SWITCH IS TURNED ON, HEAD LAMP DOES NOT LIGHTS UP

- Before disconnecting the connector, always turn the starting switch OFF.
- Before carrying out below procedure, check all the related connectors are properly inserted and short of fuse No. 19.
- After checking, insert the disconnected connectors again immediately unless otherwise specified.

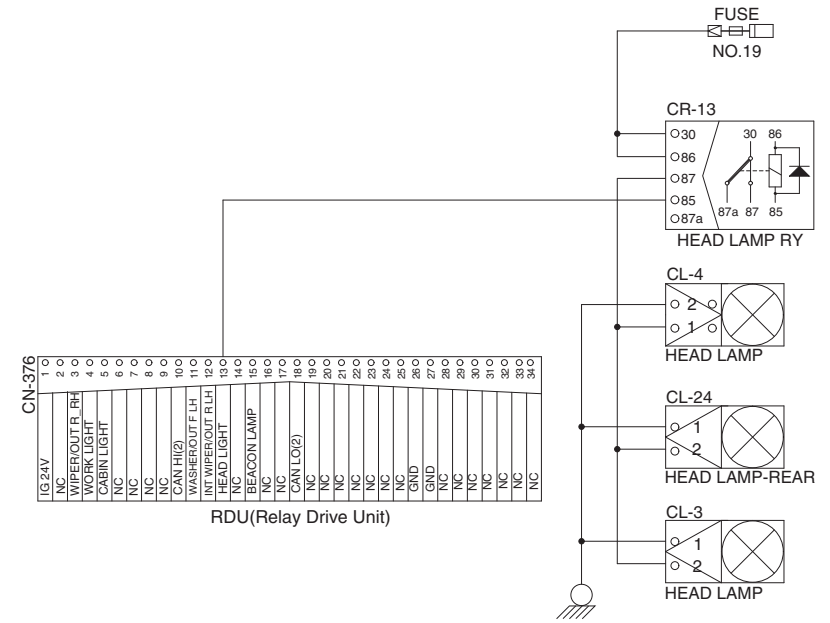
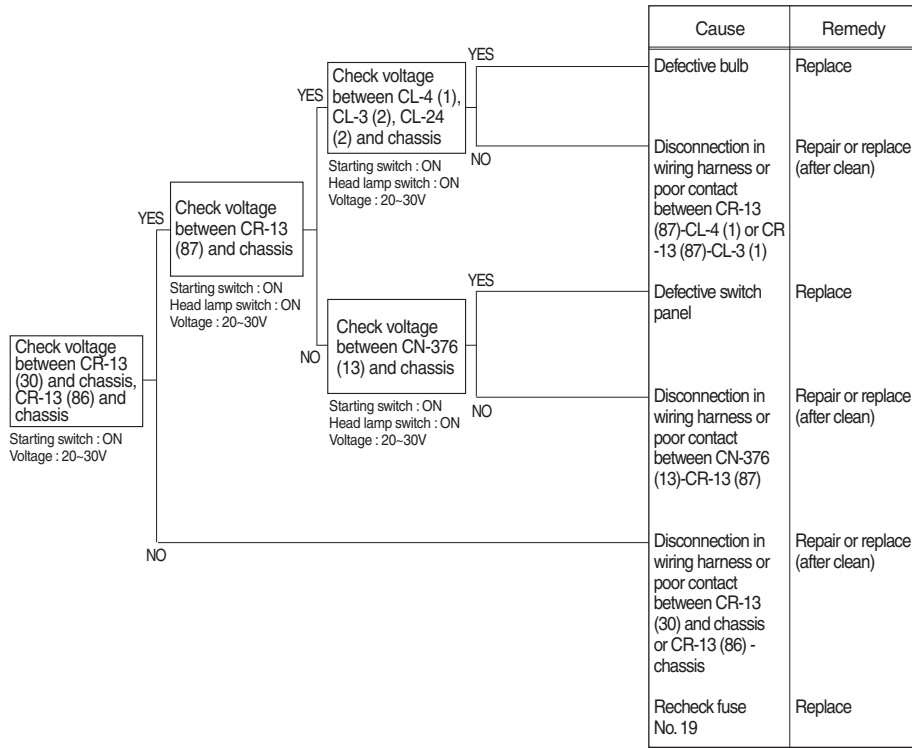

16. WHEN STARTING SWITCH IS TURNED ON, WORK LAMP DOES NOT LIGHTS UP

- Before disconnecting the connector, always turn the starting switch OFF.
- Before carrying out below procedure, check all the related connectors are properly inserted and short of fuse No.16.
- After checking, insert the disconnected connectors again immediately unless otherwise specified.

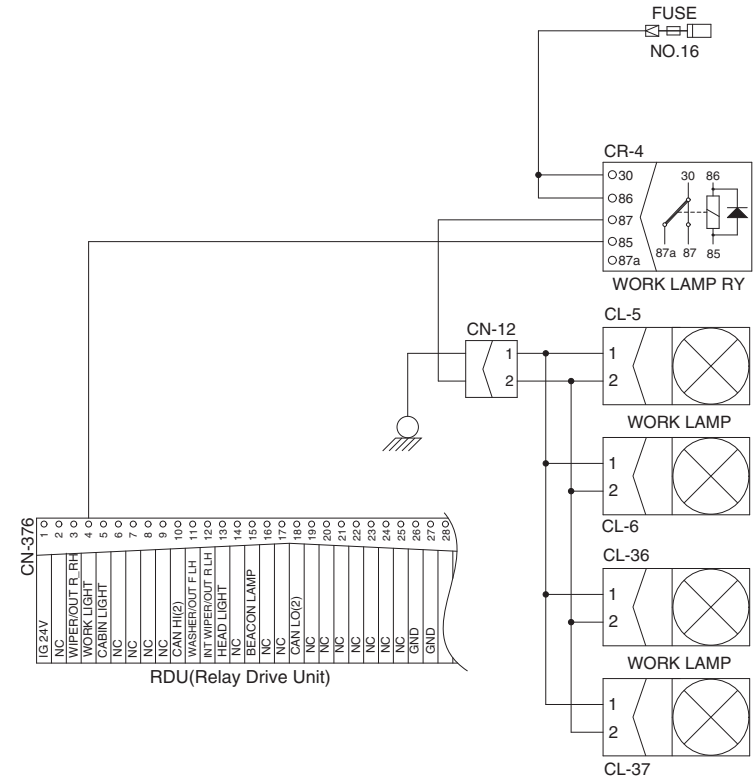
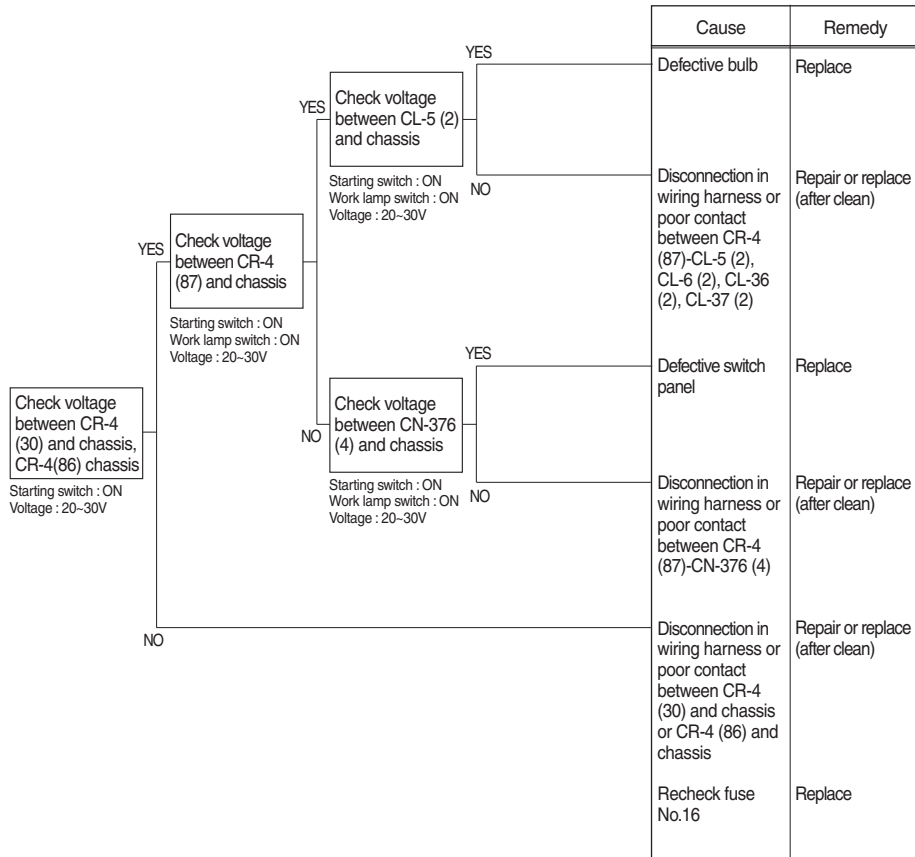

GROUP 4 MECHATRONICS SYSTEM

1. ALL ACTUATORS SPEED ARE SLOW

- ※ Boom, Arm, Bucket, Swing and travel speed are slow, but engine speed is good.
- ※ Spec : P-mode 1700 ± 50 rpm S-mode 1600 ± 50 rpm E-mode 1500 ± 50 rpm
- ※ Before carrying out below procedure, check all the related connectors are properly inserted and fault code on the cluster.

1) INSPECTION PROCEDURE

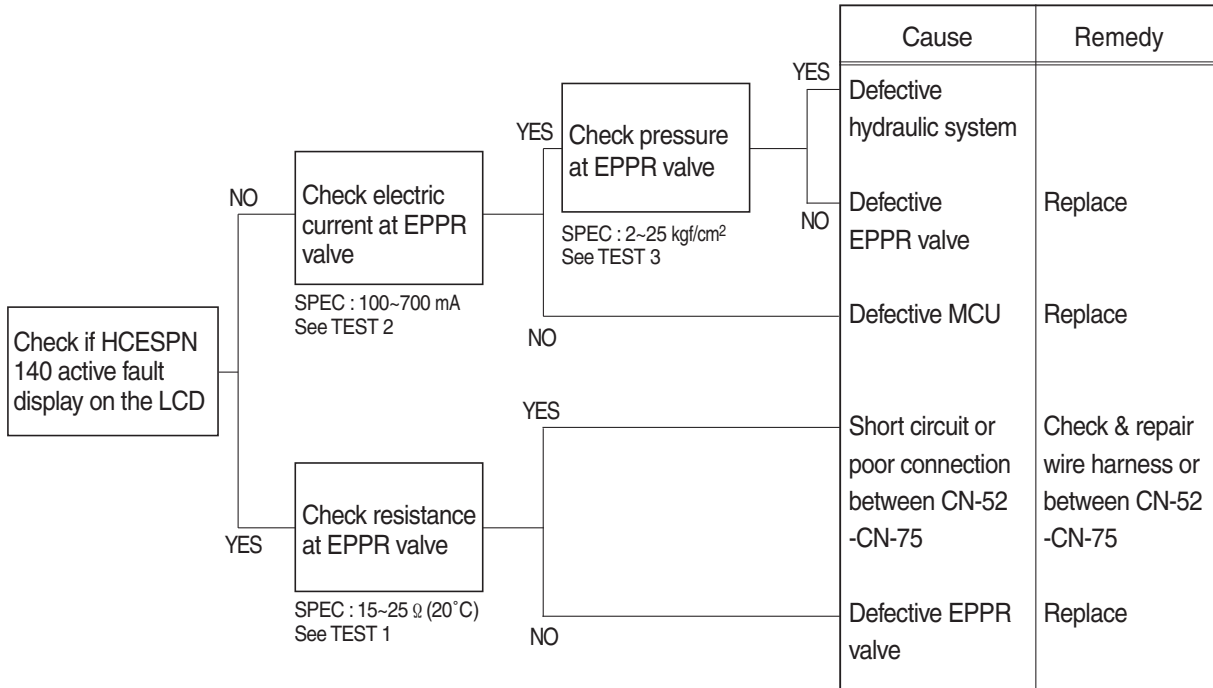

Wiring diagram

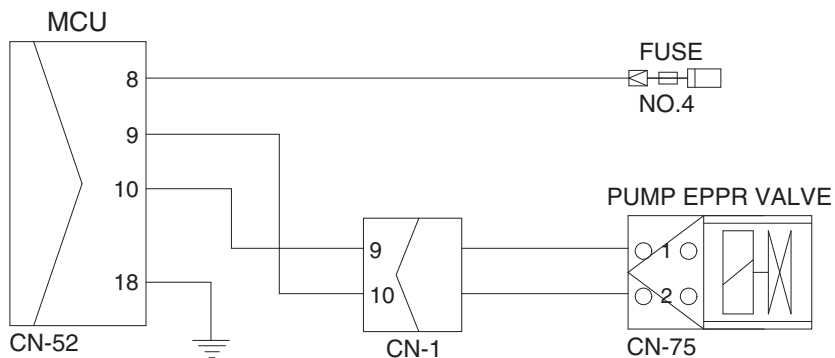

380L6MS01

2) TEST PROCEDURE

(1) **Test 1** : Check resistance at connector CN-75.

- ① Starting key OFF.
- ② Disconnect connector CN-75 from EPPR valve at main hydraulic pump.
- ③ Check resistance between 2 lines as figure.

SPEC : 15~25 Ω (20°C)

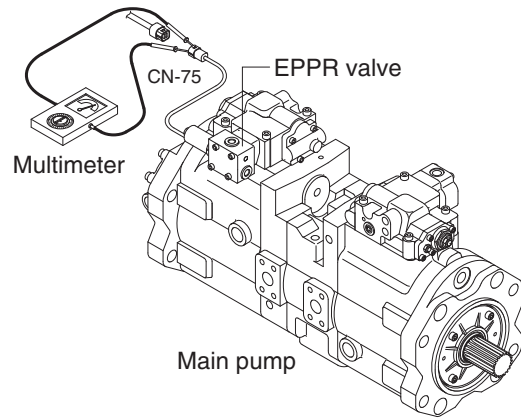

480L6MS02

(2) **Test 2** : Check electric current at EPPR valve.

- ① Disconnect connector CN-75 from EPPR valve.
- ② Insert the adapter to CN-75 and install multimeter as figure.
- ③ Start engine.
- ④ Set S-mode and cancel auto decel mode.
- ⑤ Position the multimodal dial at 10.
- ⑥ If tachometer show approx 1600 ± 50 rpm disconnect one wire harness from EPPR valve.
- ⑦ Check electric current at bucket circuit relief position.

Spec : 100~700 mA

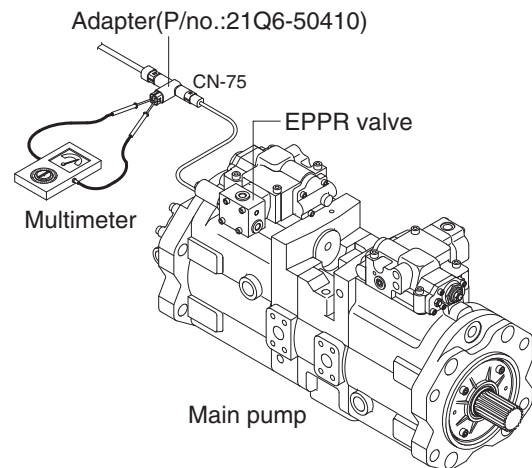

480F5MS11

(3) **Test 3** : Check pressure at EPPR valve.

- ① Remove plug and connect pressure gauge as figure.
 - Gauge capacity : 0 to 50 kgf/cm^2 (0 to 725 psi)
- ② Start engine.
- ③ Set S-mode and cancel auto decel mode.
- ④ Position the multimodal dial at 10.
- ⑤ If tachometer show approx 1600 ± 50 rpm check pressure at relief position of bucket circuit by operating bucket control lever.
- ⑥ If pressure is not correct, adjust it.
- ⑦ After adjust, test the machine.

Spec : 2~25 kgf/cm^2 (30~350 psi)

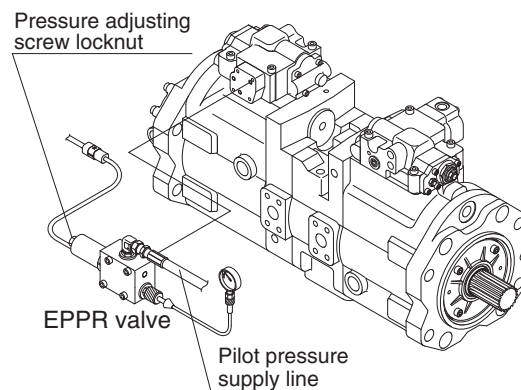

480F5MS12

2. ENGINE STALL

※ Before carrying out below procedure, check all the related connectors are properly inserted.

1) INSPECTION PROCEDURE

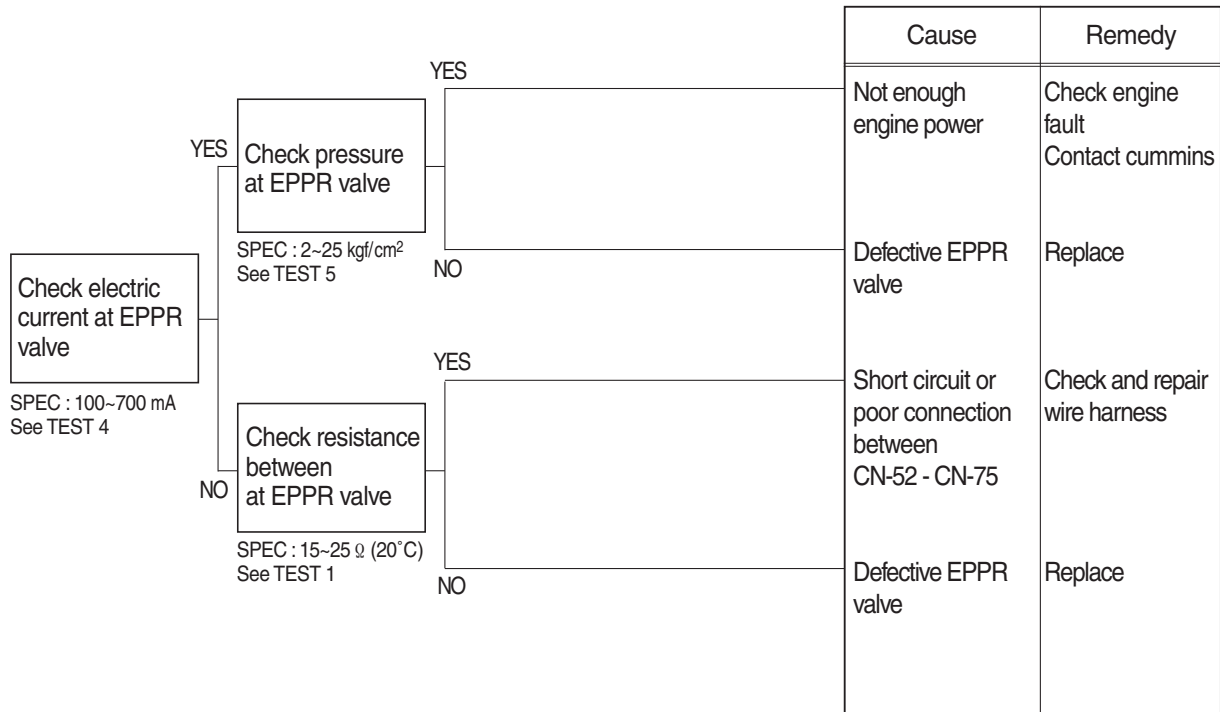

Wiring diagram

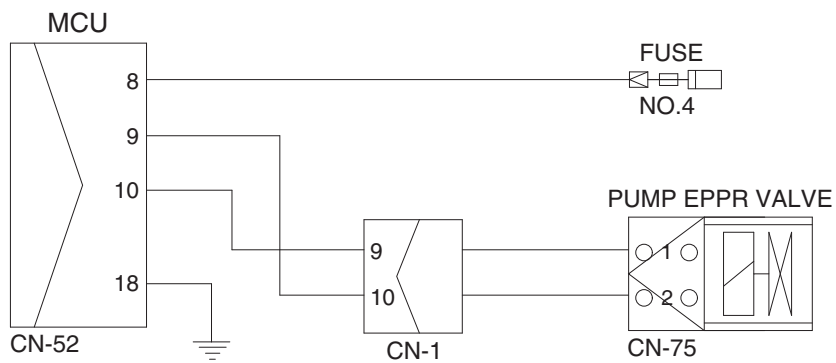

380L6MS01

2) TEST PROCEDURE

(1) Test 4 : Check electric current at EPPR valve.

- ① Disconnect connector CN-75 from EPPR valve.
- ② Insert the adapter to CN-75 and install multimeter as figure.
- ③ Start engine.
- ④ Set S-mode and cancel auto decel mode.
- ⑤ Position the multimodal dial at 10.
- ⑥ If rpm show approx 1600 ± 50 rpm disconnect one wire harness from EPPR valve.
- ⑦ Check electric current at bucket circuit relief position.

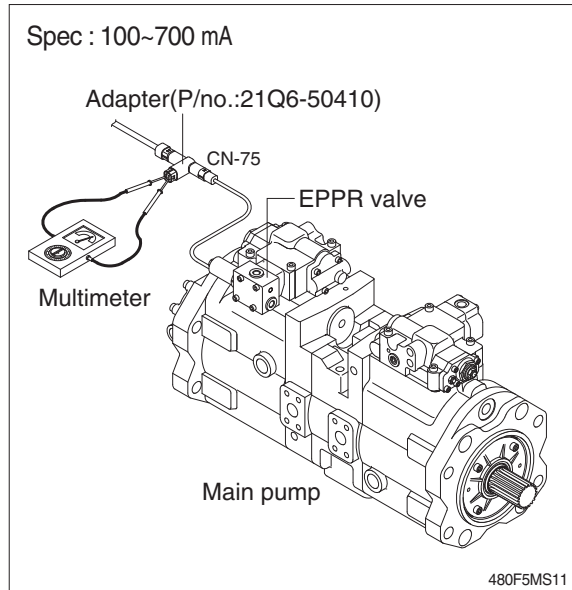

(2) Test 5 : Check pressure at EPPR valve.

- ① Remove plug and connect pressure gauge as figure.
 - Gauge capacity : 0 to 50 kgf/cm²
(0 to 725 psi)
- ② Start engine.
- ③ Set S-mode and cancel auto decel mode.
- ④ Position the multimodal dial at 10.
- ⑤ If rpm show approx 1600 ± 50 rpm check pressure at relief position of bucket circuit by operating bucket control lever.
- ⑥ If pressure is not correct, adjust it.
- ⑦ After adjust, test the machine.

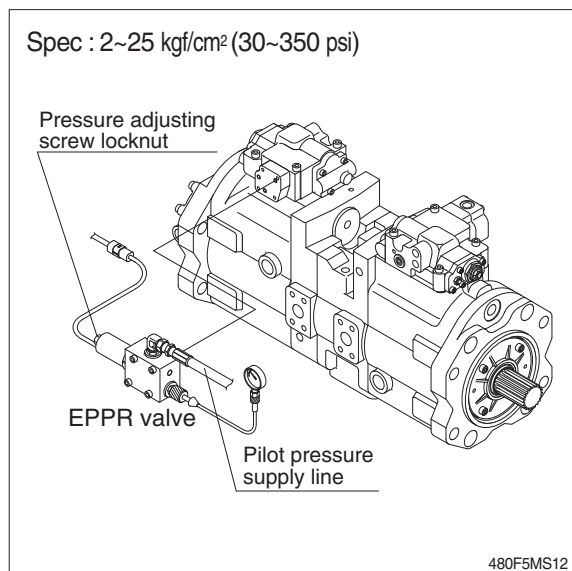

3. MALFUNCTION OF CLUSTER OR MODE SELECTION SYSTEM

※ Before carrying out below procedure, check all the related connectors are properly inserted.

1) INSPECTION PROCEDURE

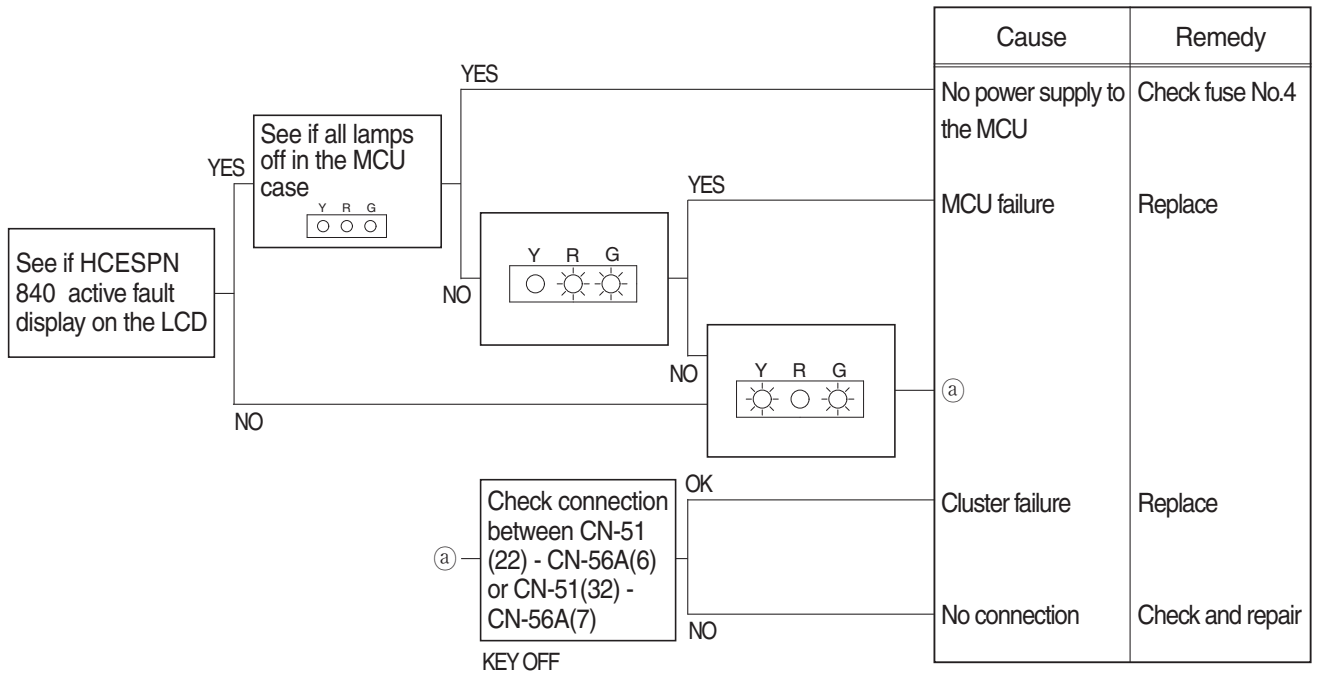

Wiring diagram

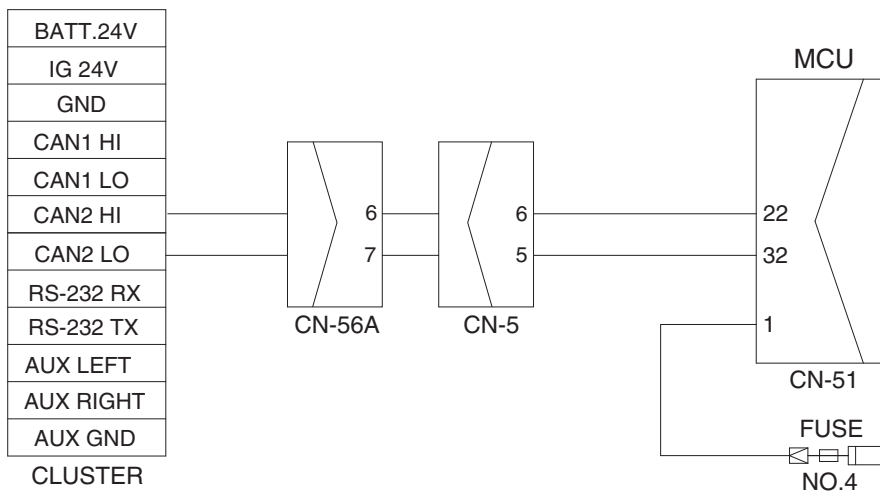

380L6MS03

4. AUTO DECEL SYSTEM DOES NOT WORK

- Fault code : HCESPN 105, FMI 0~4 (work pressure sensor)
HCESPN 108, FMI 0~4 (travel oil pressure sensor)

※ Before carrying out below procedure, check all the related connectors are properly inserted.

1) INSPECTION PROCEDURE

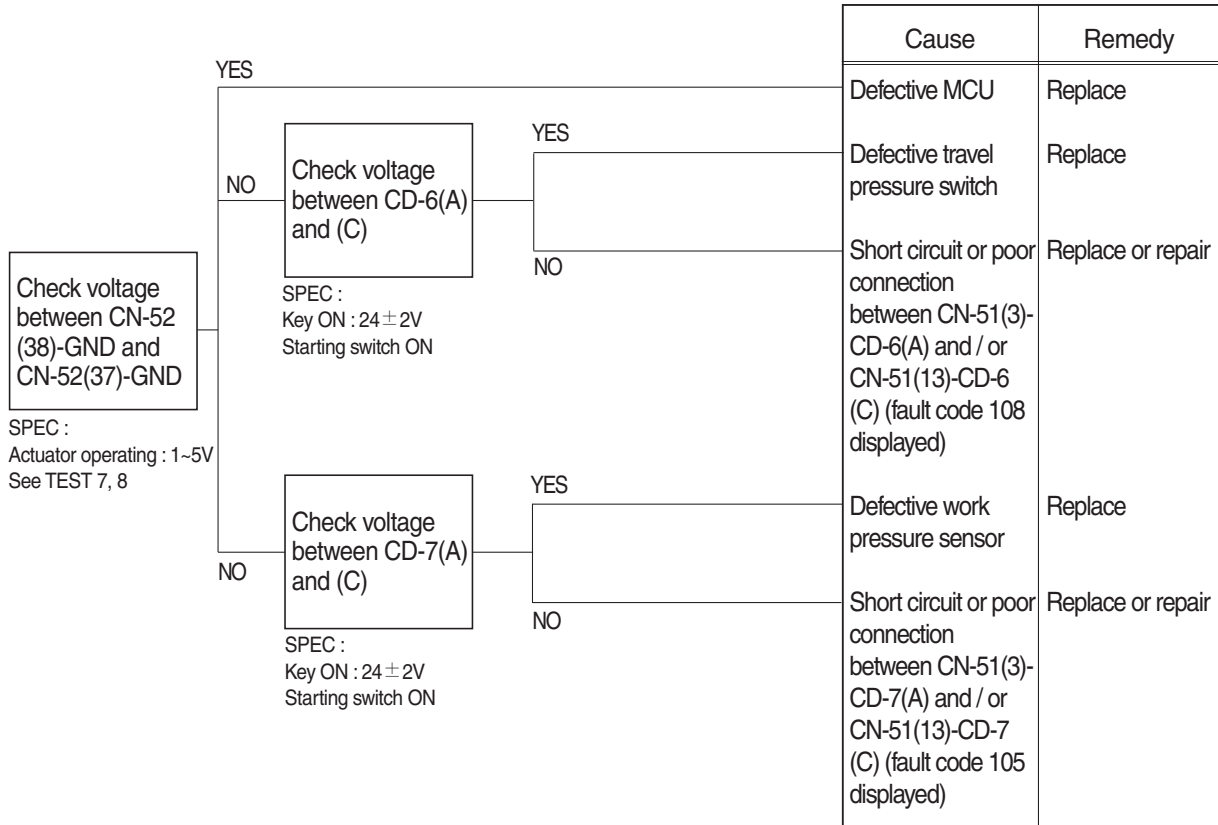

Wiring diagram

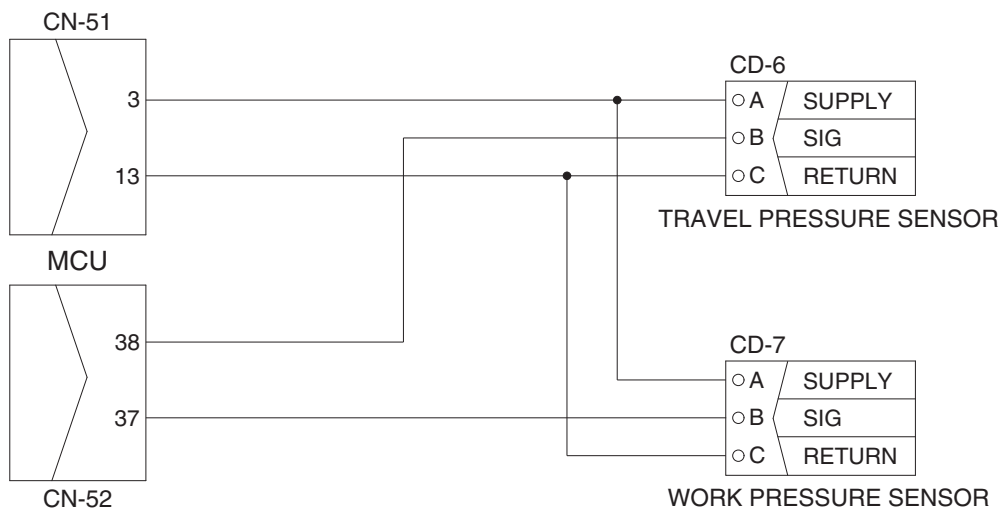

300L6MS03

2) TEST PROCEDURE

(1) **Test 7** : Check voltage at CN-52 (38) and ground.

- ① Prepare 1 piece of thin sharp pin, steel or copper.
- ② Insert prepared pin to rear side of connectors : One pin to (38) of CN-52.
- ③ Starting switch ON.
- ④ Check voltage as figure.

(2) **Test 8** : Check voltage at CN-52 (37) and ground.

- ① Prepare 1 piece of thin sharp pin, steel or copper
- ② Insert prepared pin to rear side of connectors : One pin to (37) of CN-52.
- ③ Starting switch ON.
- ④ Check voltage as figure.

SPEC : Actuator operating : 1~5 V

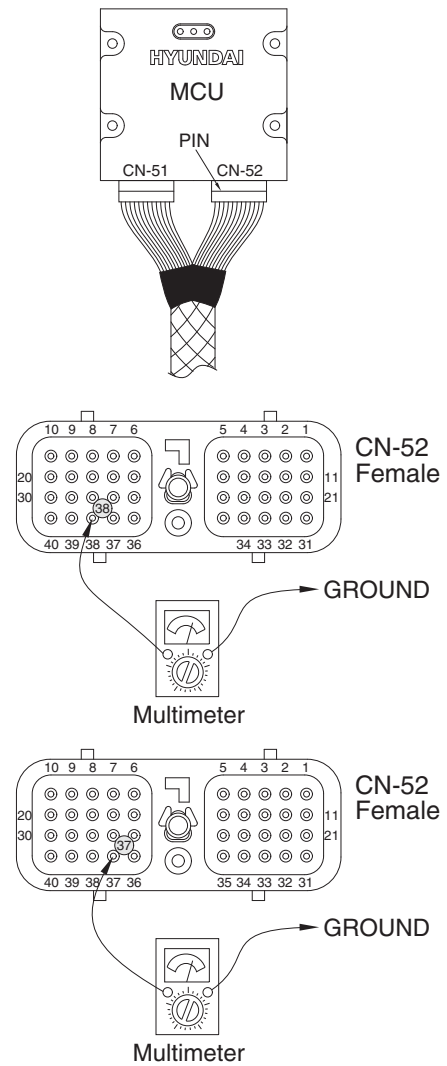

300L6MS04

5. MALFUNCTION OF PUMP 1 PRESSURE SENSOR

· Fault code : HCESPN 121, FMI 0~4

※ Before carrying out below procedure, check all the related connectors are properly inserted.

1) INSPECTION PROCEDURE

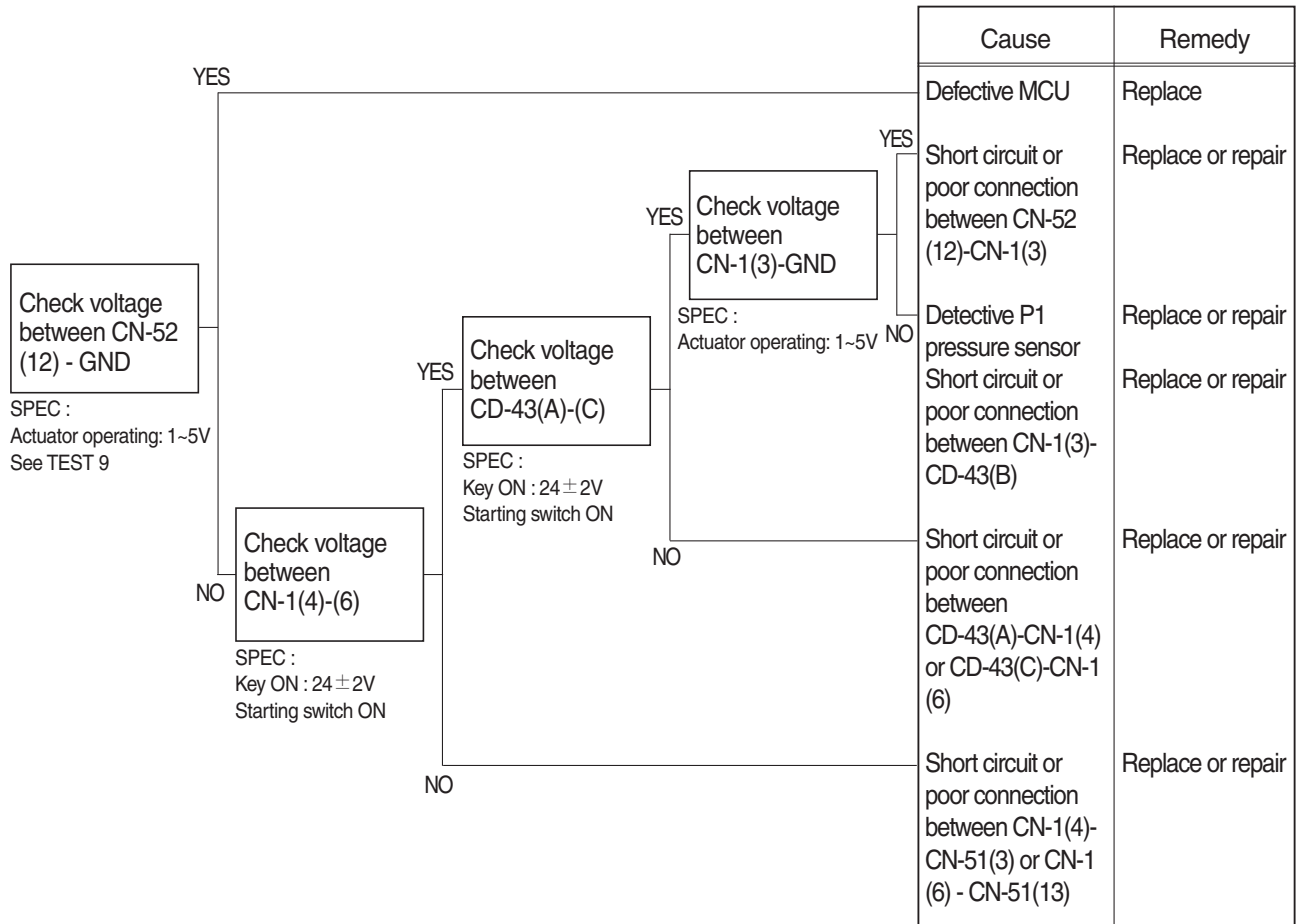

Wiring diagram

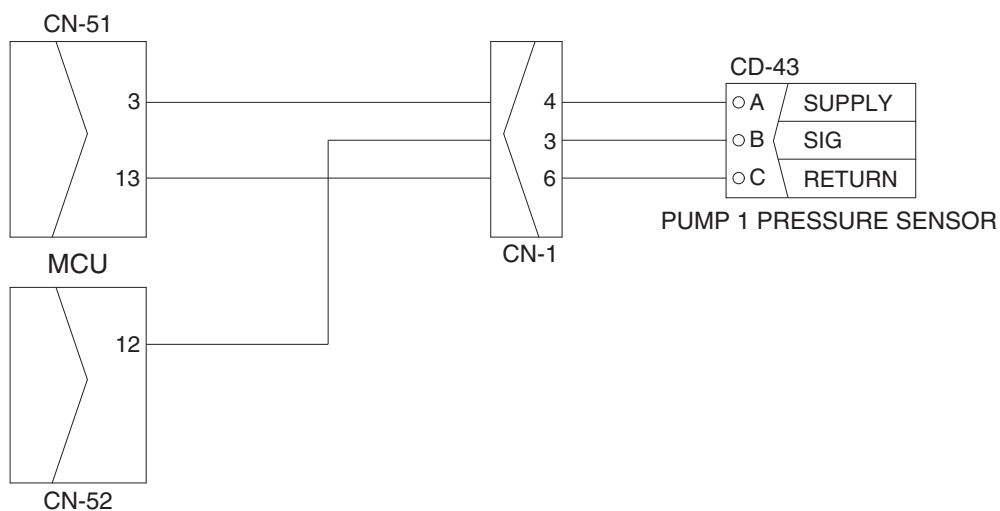

2) TEST PROCEDURE

(1) Test 9 : Check voltage at CN-52 (12) and ground.

- ① Prepare 1 piece of thin sharp pin, steel or copper.
- ② Insert prepared pin to rear side of connectors : One pin to (12) of CN-52.
- ③ Starting switch ON.
- ④ Check voltage as figure.

SPEC : Actuator operating : 1~5 V

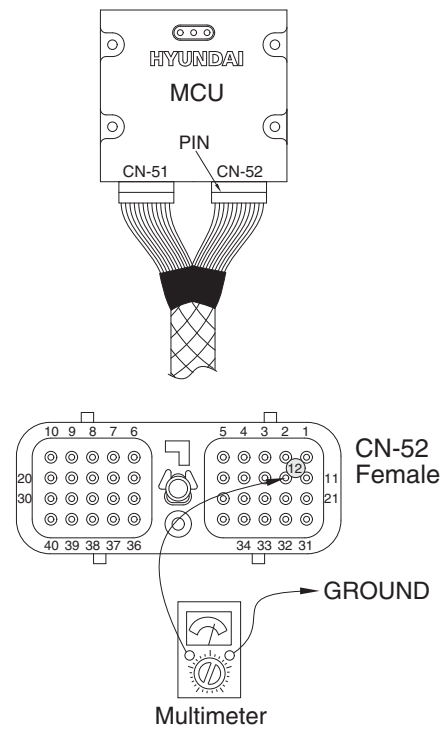

300L6MS08

6. MALFUNCTION OF PUMP 2 PRESSURE SENSOR

· Fault code : HCESPN 120, FMI 0~4

※ Before carrying out below procedure, check all the related connectors are properly inserted.

1) INSPECTION PROCEDURE

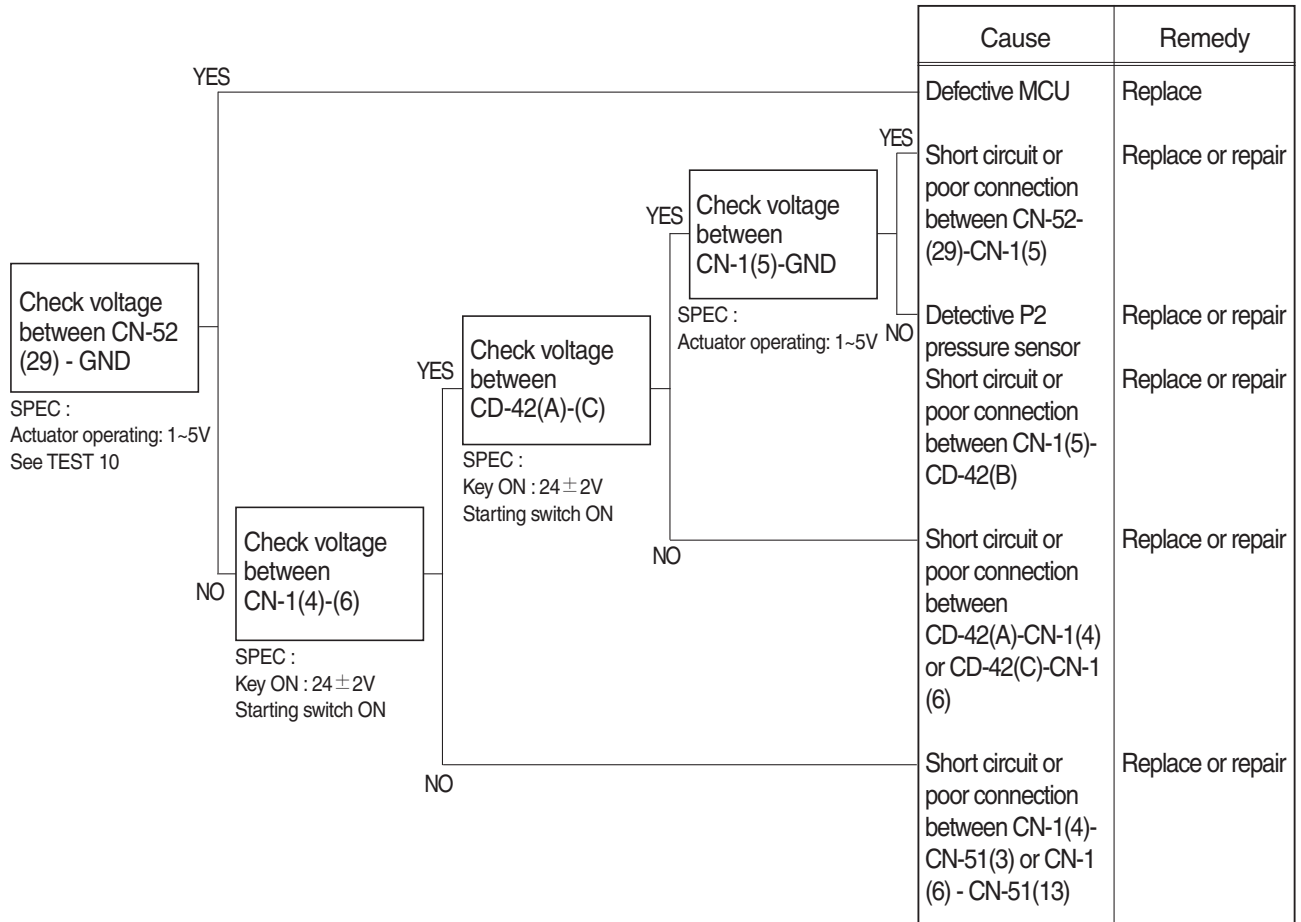

Wiring diagram

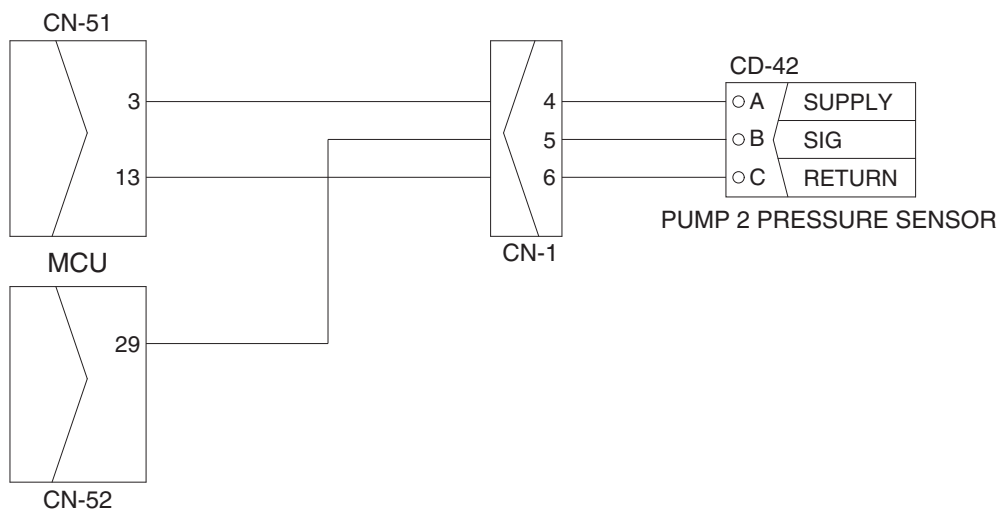

2) TEST PROCEDURE

(1) **Test 10** : Check voltage at CN-52 (29) and ground.

- ① Prepare 1 piece of thin sharp pin, steel or copper.
- ② Insert prepared pin to rear side of connectors : One pin to (29) of CN-52.
- ③ Starting switch ON.
- ④ Check voltage as figure.

SPEC : Actuator operating : 1~5 V

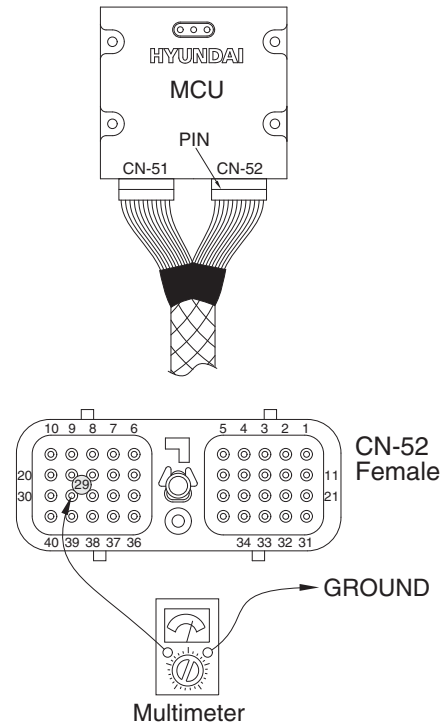

300L6MS06

7. MALFUNCTION OF PUMP 3 PRESSURE SENSOR

※ Before carrying out below procedure, check all the related connectors are properly inserted.

1) INSPECTION PROCEDURE

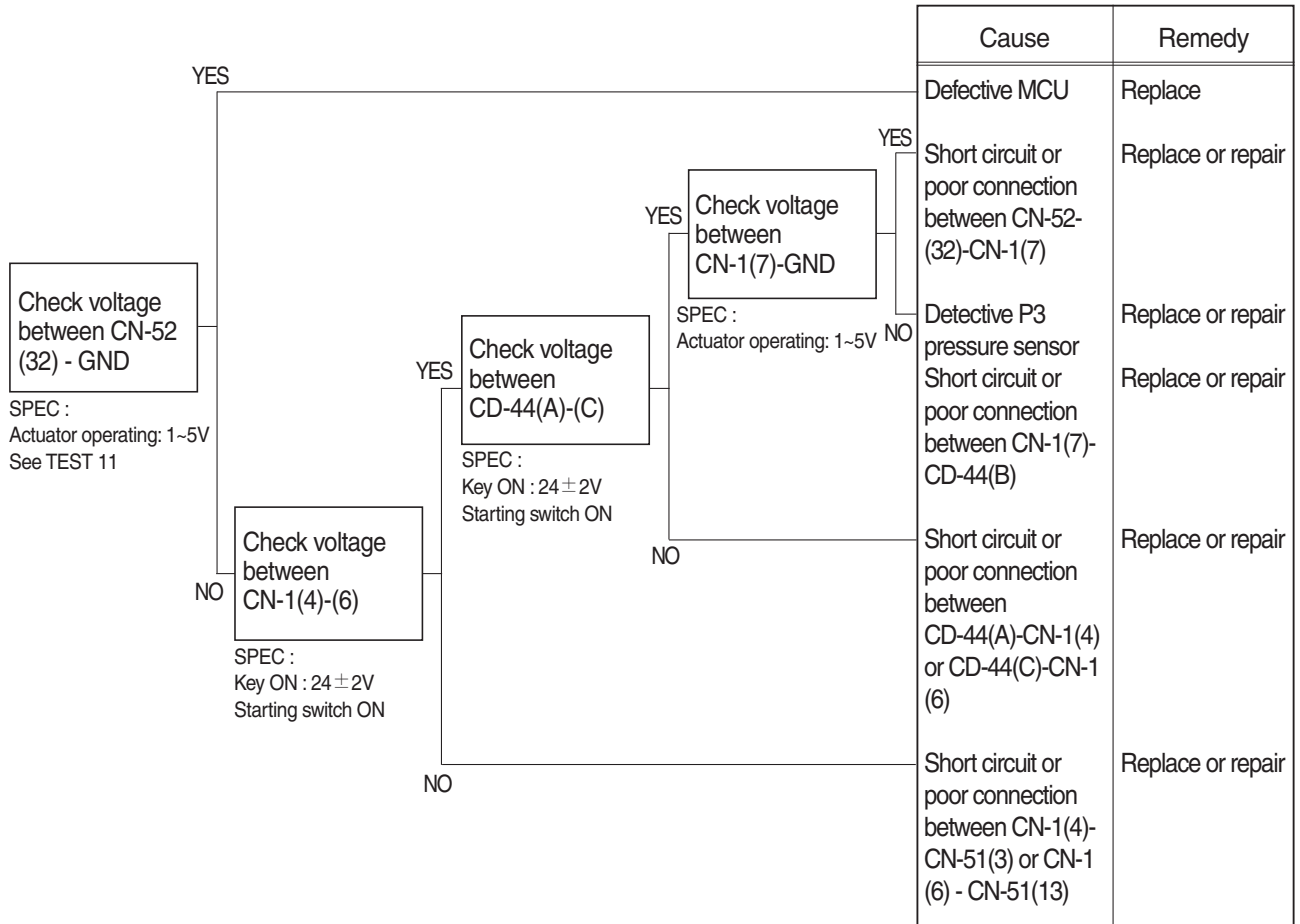

Wiring diagram

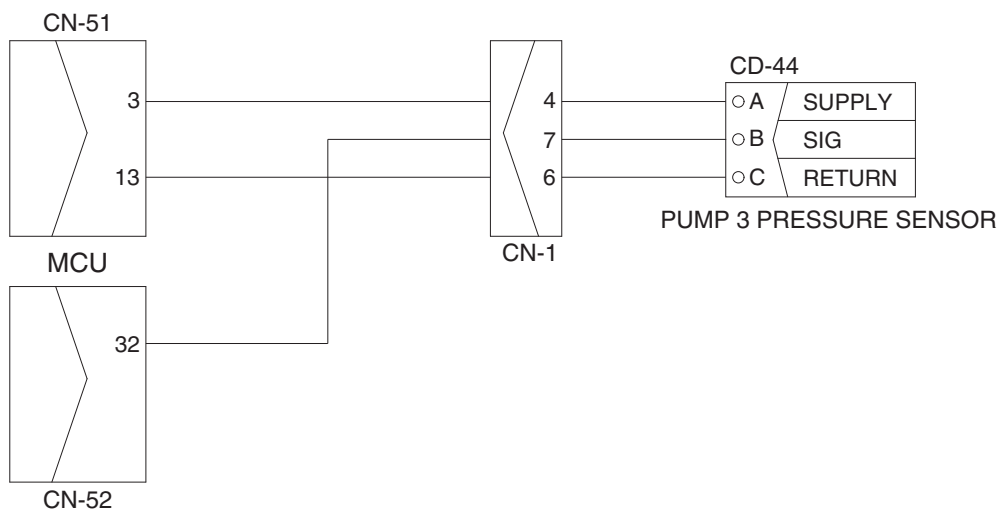

2) TEST PROCEDURE

(1) **Test 11** : Check voltage at CN-52 (32) and ground.

- ① Prepare 1 piece of thin sharp pin, steel or copper.
- ② Insert prepared pin to rear side of connectors : One pin to (32) of CN-52.
- ③ Starting switch ON.
- ④ Check voltage as figure.

SPEC : Actuator operating : 1~5 V

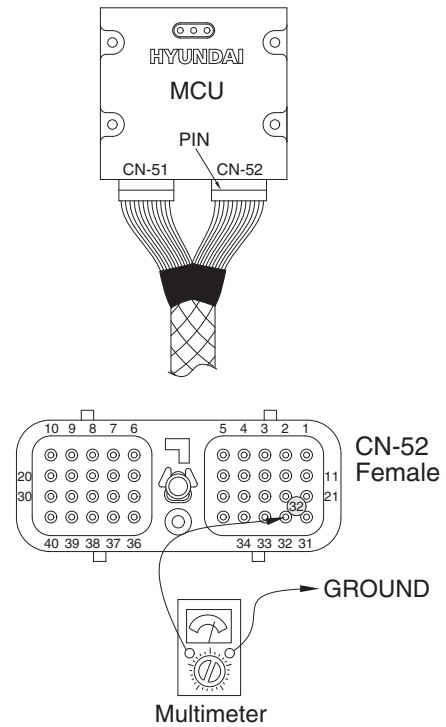

300L6MS10

8. MALFUNCTION OF NEGATIVE 1 PRESSURE SENSOR

· Fault code : HCESPN 123, FMI 0~4

※ Before carrying out below procedure, check all the related connectors are properly inserted.

1) INSPECTION PROCEDURE

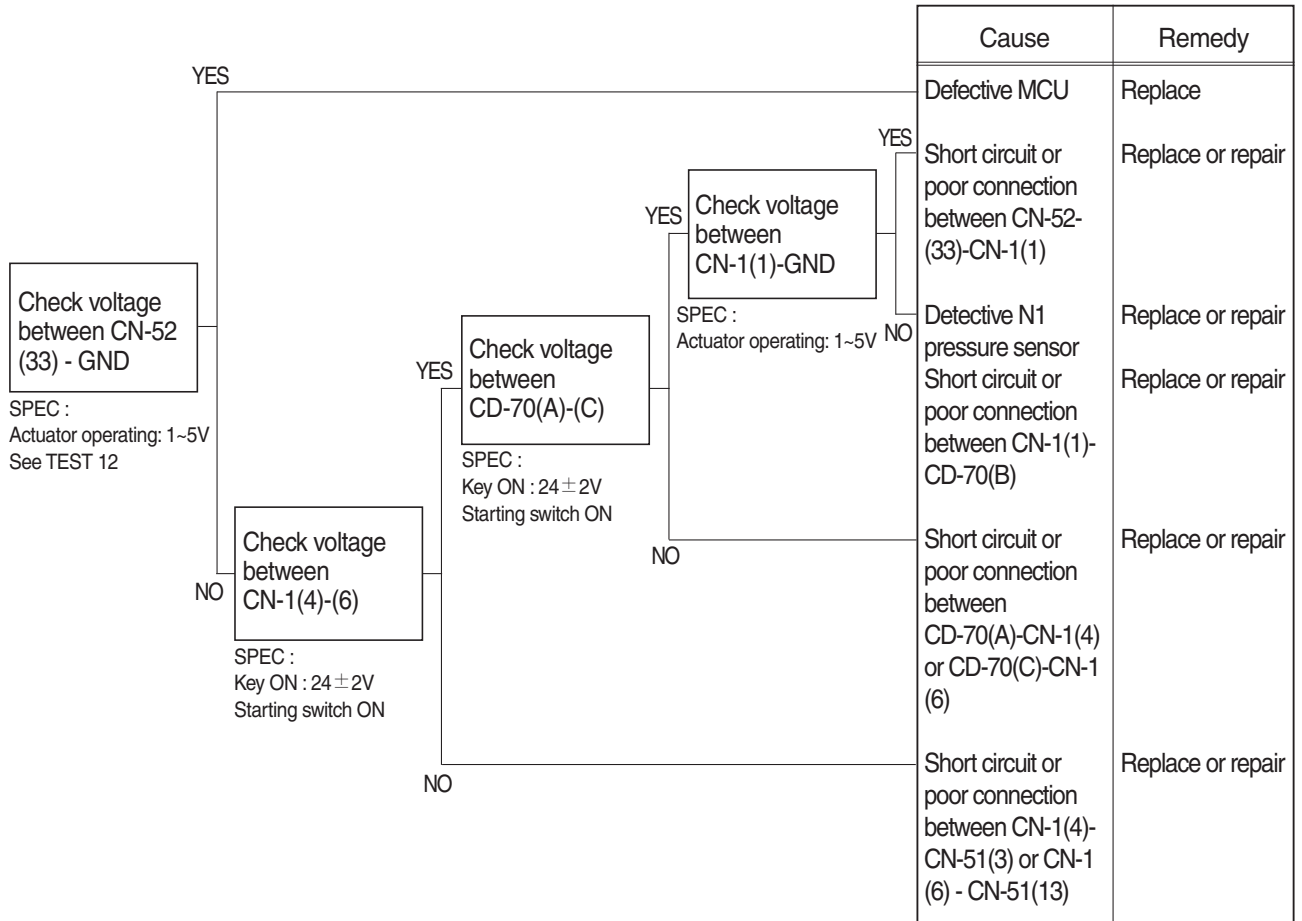

Wiring diagram

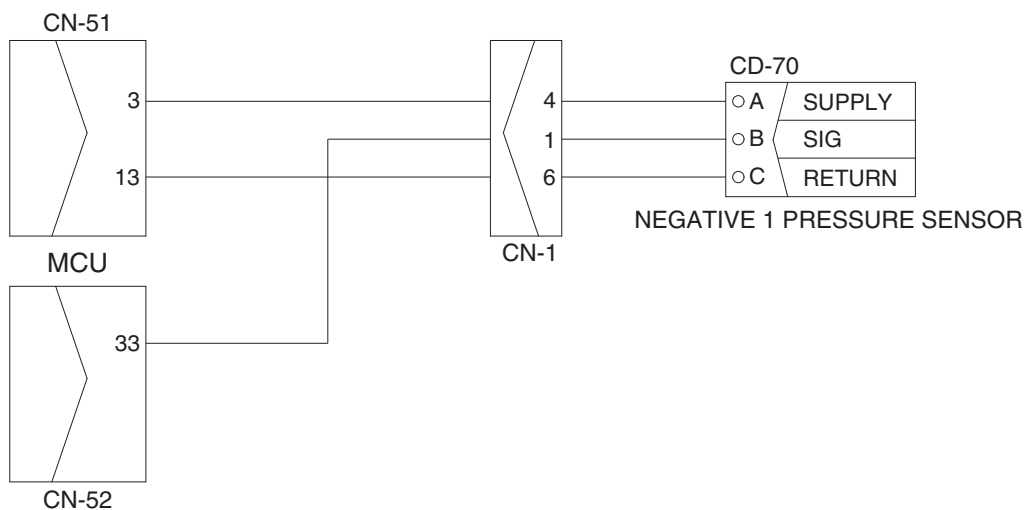

2) TEST PROCEDURE

(1) **Test 12** : Check voltage at CN-52 (33) and ground.

- ① Prepare 1 piece of thin sharp pin, steel or copper.
- ② Insert prepared pin to rear side of connectors : One pin to (33) of CN-52.
- ③ Starting switch ON.
- ④ Check voltage as figure.

SPEC : Actuator operating : 1~5 V

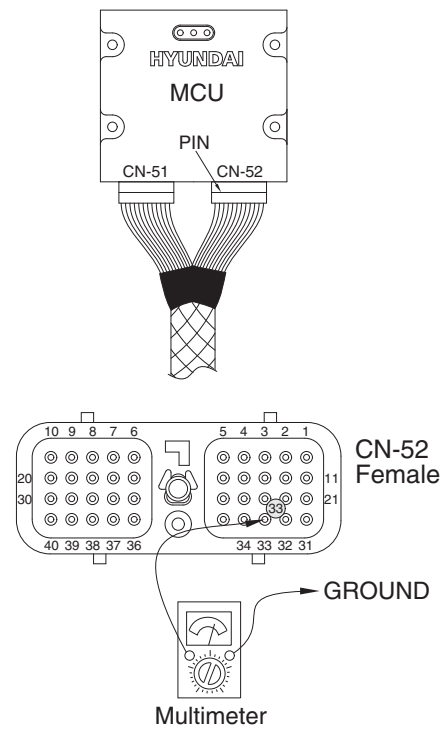

300L6MS12

9. MALFUNCTION OF NEGATIVE 2 PRESSURE SENSOR

· Fault code : HCESPN 124, FMI 0~4

※ Before carrying out below procedure, check all the related connectors are properly inserted.

1) INSPECTION PROCEDURE

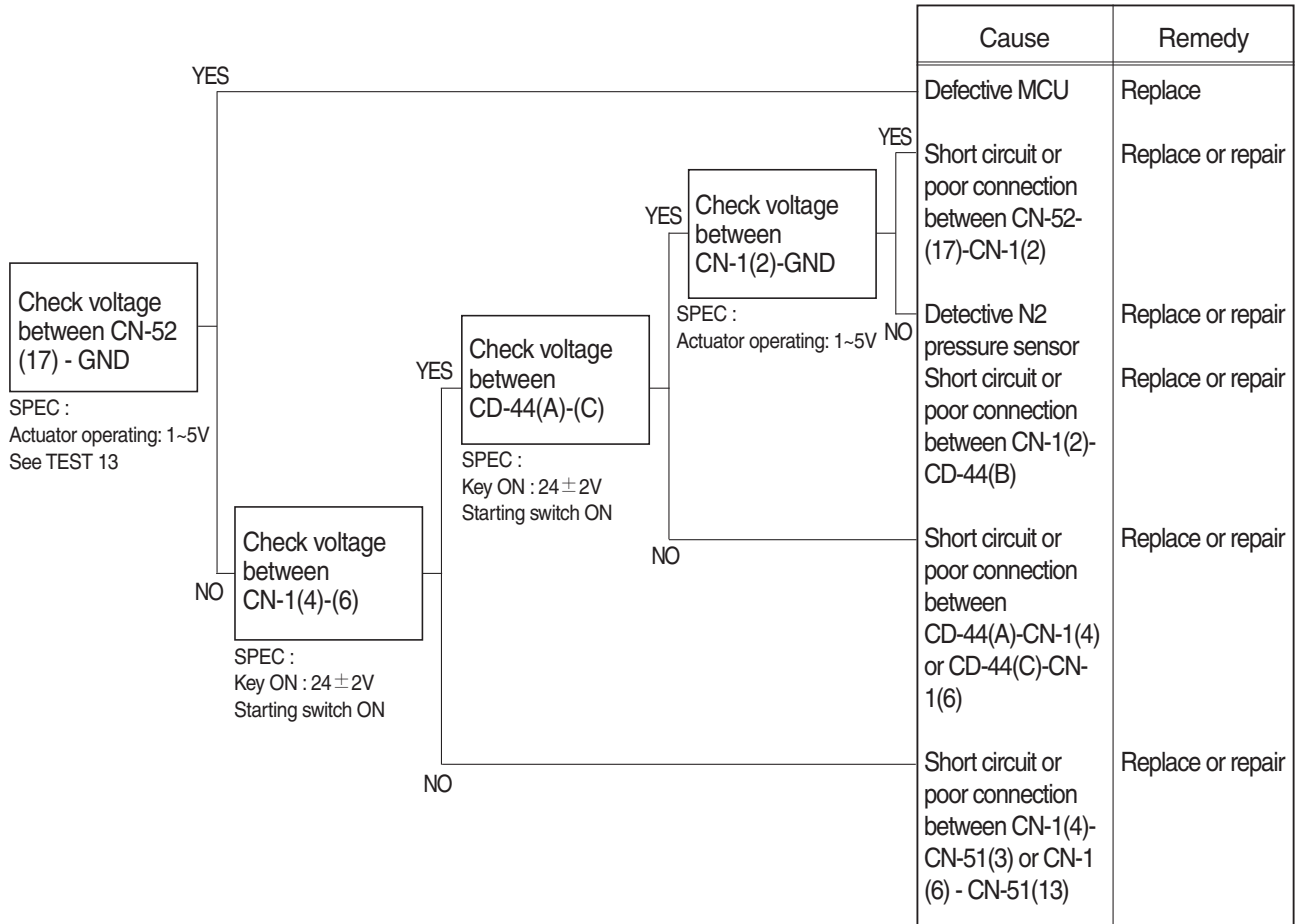

Wiring diagram

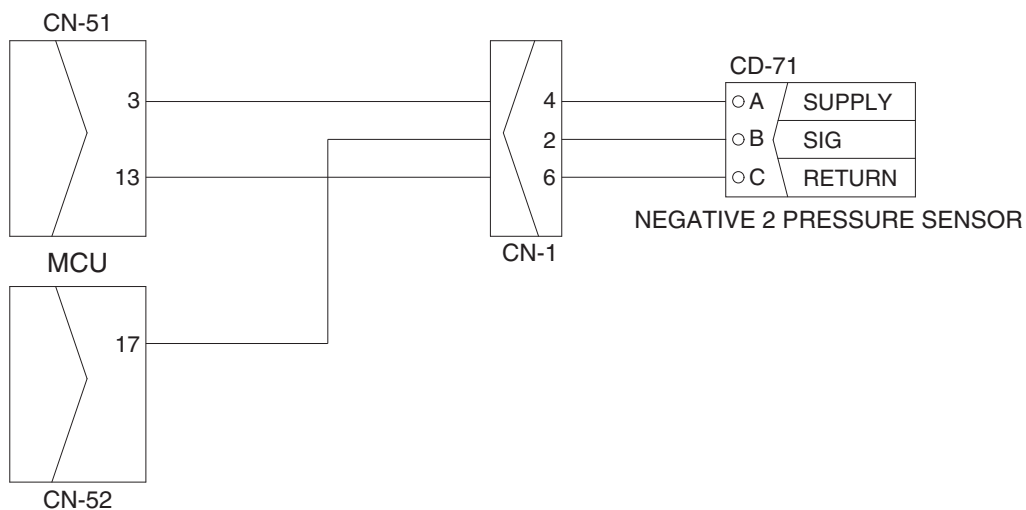

2) TEST PROCEDURE

(1) **Test 13** : Check voltage at CN-52 (17) and ground.

- ① Prepare 1 piece of thin sharp pin, steel or copper.
- ② Insert prepared pin to rear side of connectors : One pin to (17) of CN-52.
- ③ Starting switch ON.
- ④ Check voltage as figure.

SPEC : Actuator operating : 1~5 V

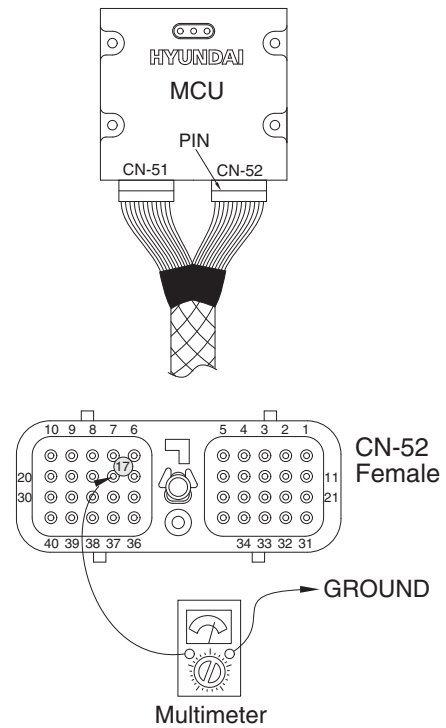

300L6MS14

10. MALFUNCTION OF SWING PRESSURE SENSOR

· Fault code : HCESPN 135, FMI 0~4

※ Before carrying out below procedure, check all the related connectors are properly inserted.

1) INSPECTION PROCEDURE

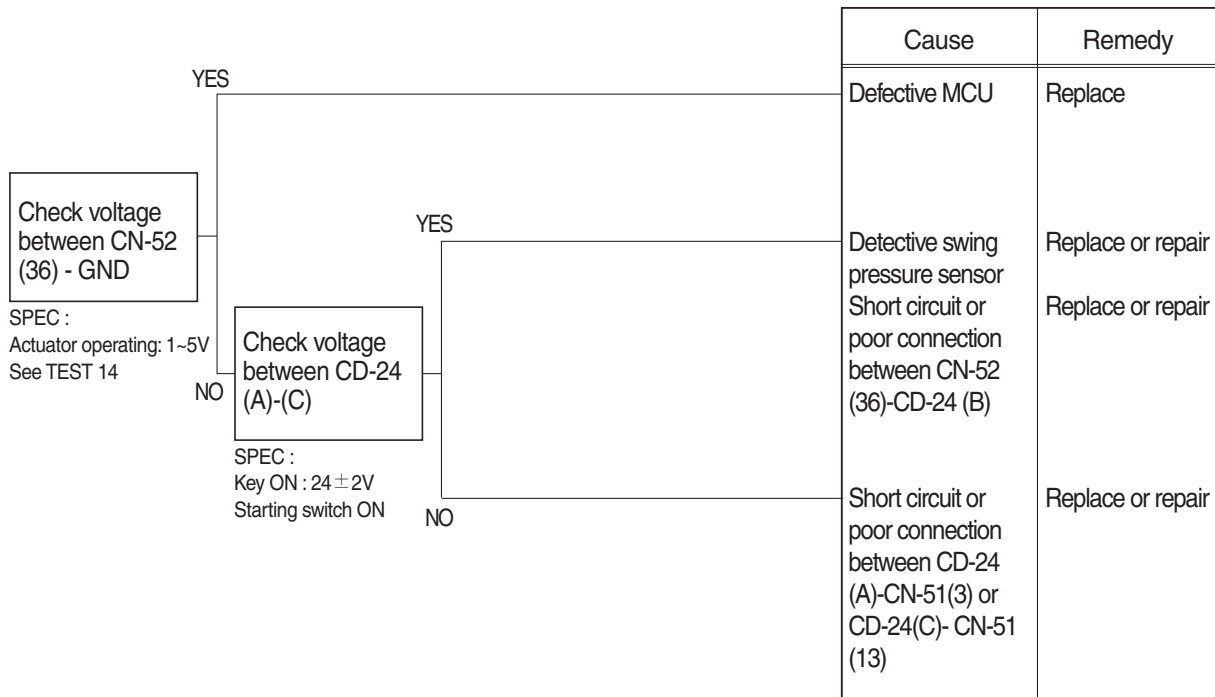

Wiring diagram

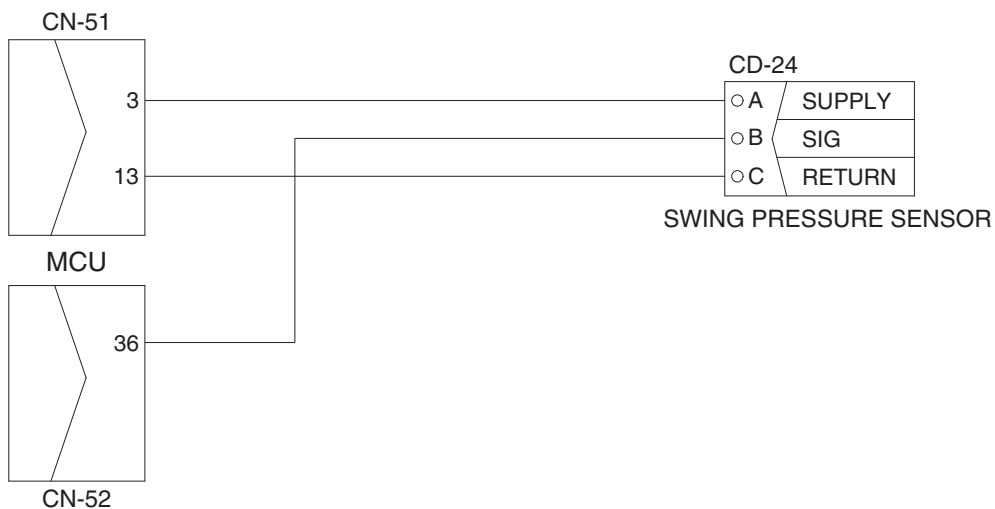

300L6MS15

2) TEST PROCEDURE

(1) Test 14 : Check voltage at CN-52 (36) and ground.

- ① Prepare 1 piece of thin sharp pin, steel or copper.
- ② Insert prepared pin to rear side of connectors : One pin to (36) of CN-52.
- ③ Starting switch ON.
- ④ Check voltage as figure.

SPEC : Actuator operating : 1~5 V

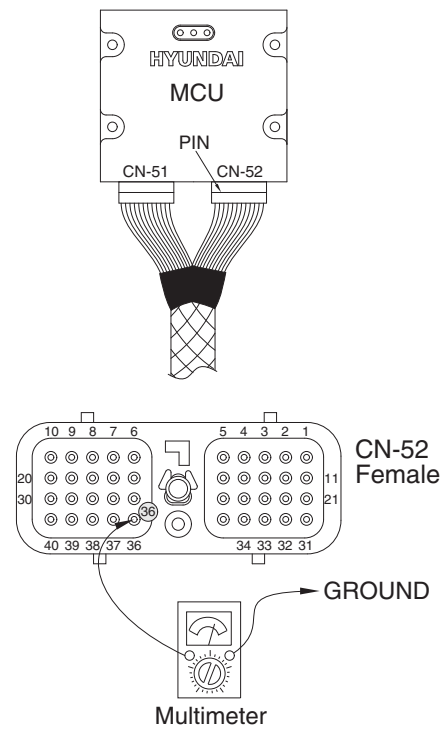

300L6MS16

11. MALFUNCTION OF ARM IN/OUT & BUCKET IN PRESSURE SENSOR

· Fault code : HCESPN 133, FMI 0~4

※ Before carrying out below procedure, check all the related connectors are properly inserted.

1) INSPECTION PROCEDURE

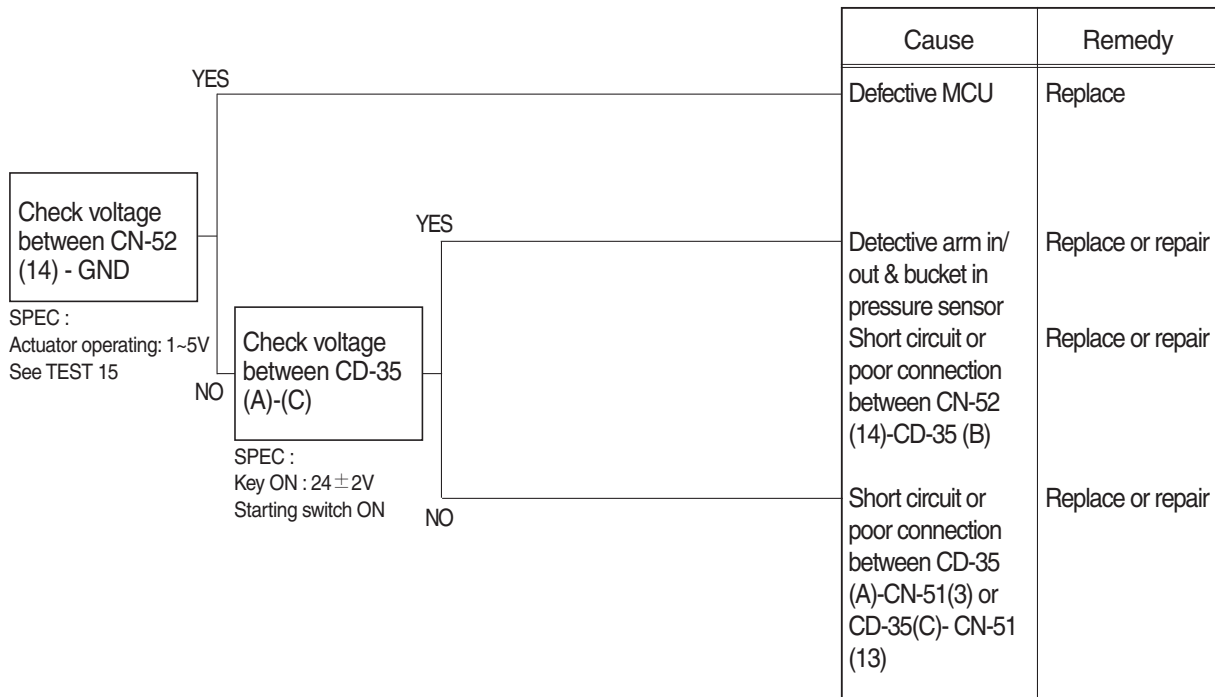

Wiring diagram

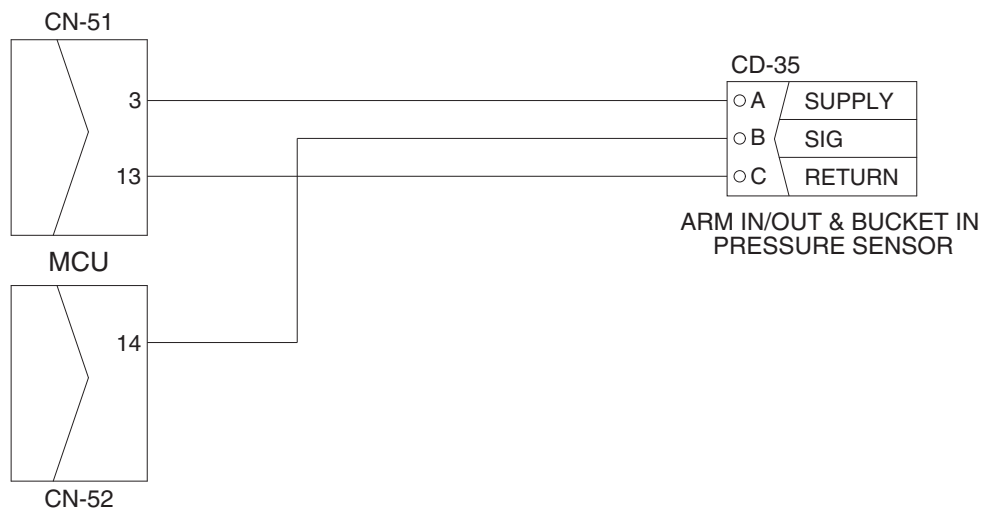

300L6MS17

2) TEST PROCEDURE

(1) **Test 15** : Check voltage at CN-52 (14) and ground.

- ① Prepare 1 piece of thin sharp pin, steel or copper.
- ② Insert prepared pin to rear side of connectors : One pin to (14) of CN-52.
- ③ Starting switch ON.
- ④ Check voltage as figure.

SPEC : Actuator operating : 1~5 V

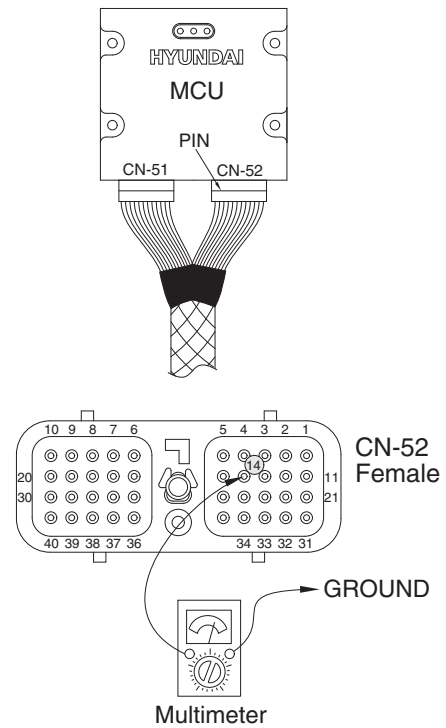

300L6MS18

12. MALFUNCTION OF BOOM UP PRESSURE SENSOR

· Fault code : HCESPN 127, FMI 0~4

※ Before carrying out below procedure, check all the related connectors are properly inserted.

1) INSPECTION PROCEDURE

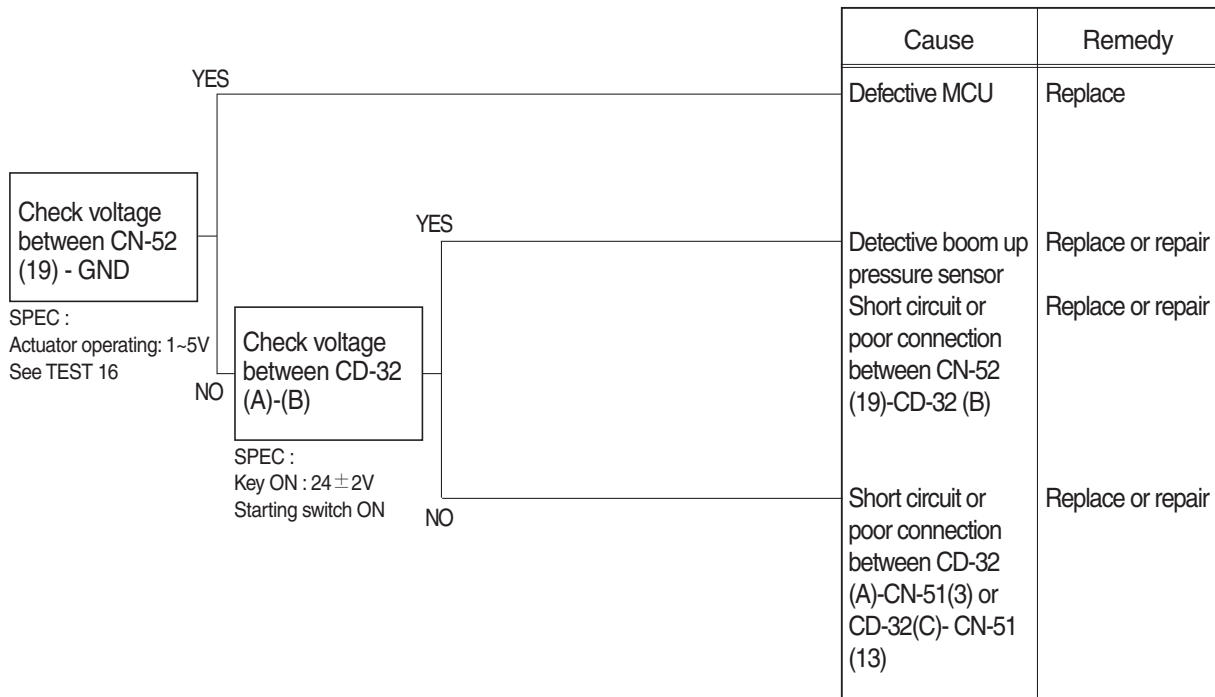

Wiring diagram

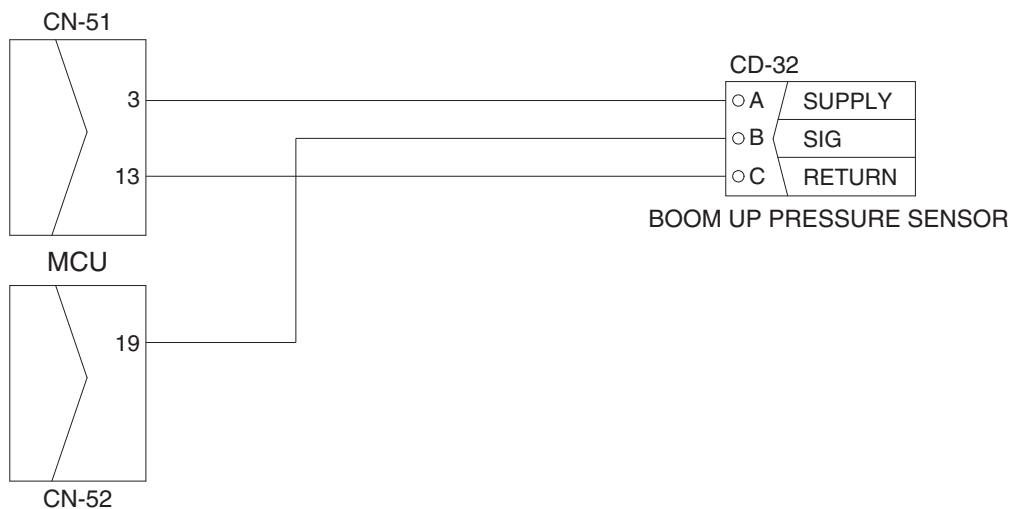

300L6MS19

2) TEST PROCEDURE

(1) **Test 16** : Check voltage at CN-52 (19) and ground.

- ① Prepare 1 piece of thin sharp pin, steel or copper.
- ② Insert prepared pin to rear side of connectors : One pin to (19) of CN-52.
- ③ Starting switch ON.
- ④ Check voltage as figure.

SPEC : Actuator operating : 1~5 V

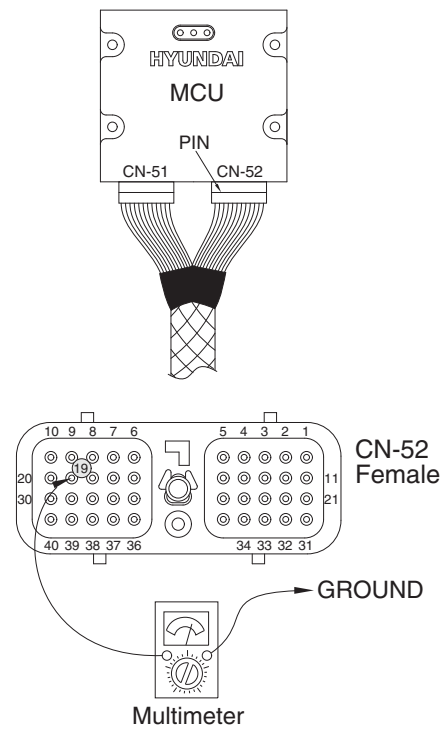

300L6MS20

13. MALFUNCTION OF BOOM DOWN PRESSURE SENSOR

· Fault code : HCESPN 128, FMI 0~4

※ Before carrying out below procedure, check all the related connectors are properly inserted.

1) INSPECTION PROCEDURE

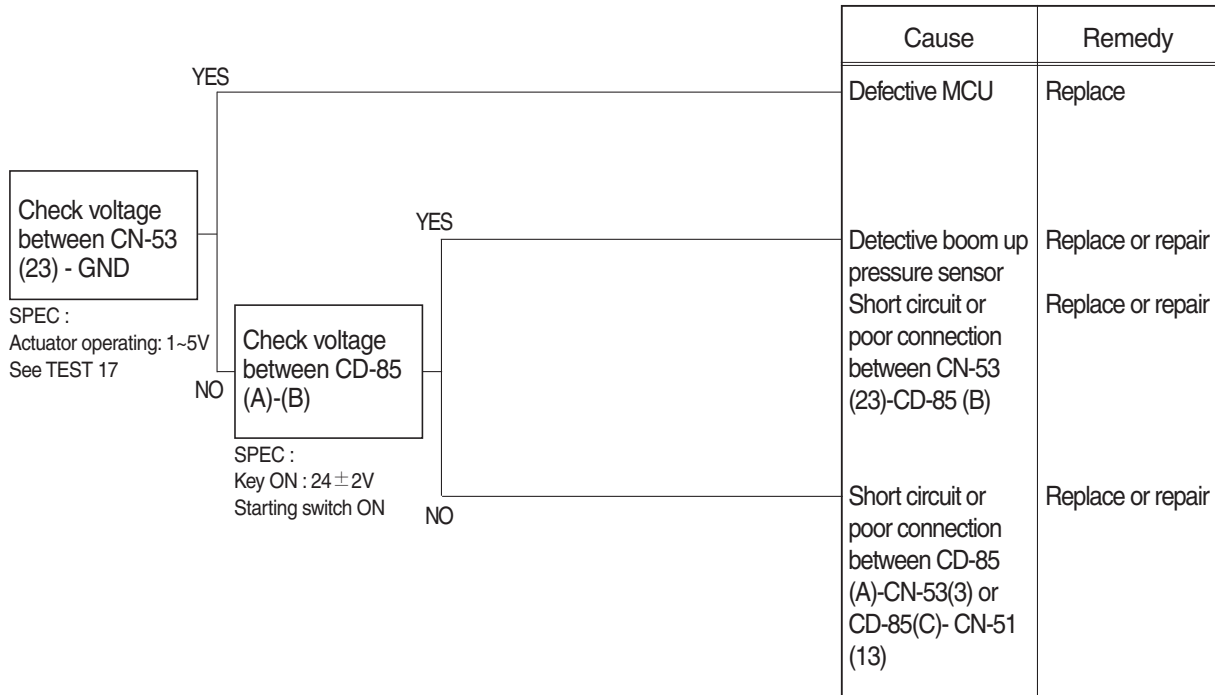

Wiring diagram

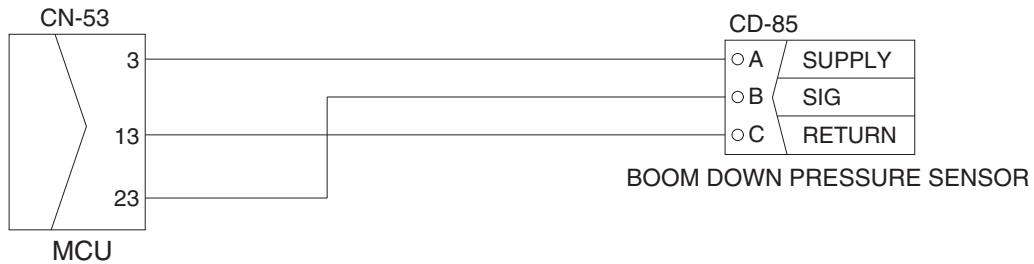

300L6MS25

2) TEST PROCEDURE

(1) **Test 17** : Check voltage at CN-53 (23) and ground.

- ① Prepare 1 piece of thin sharp pin, steel or copper.
- ② Insert prepared pin to rear side of connectors : One pin to (23) of CN-53.
- ③ Starting switch ON.
- ④ Check voltage as figure.

SPEC : Actuator operating : 1~5 V

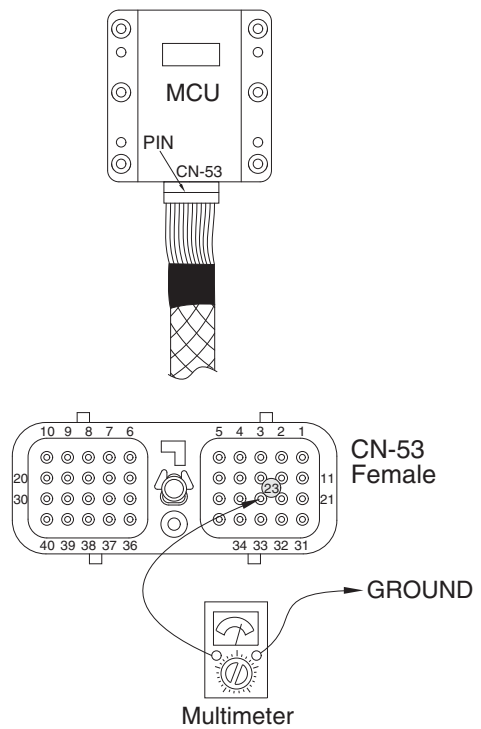

300L6MS26

14. MALFUNCTION OF POWER MAX

· Fault code : HCESPN 166, FMI 4 or 6

※ Before carrying out below procedure, check all the related connectors are properly inserted.

1) INSPECTION PROCEDURE

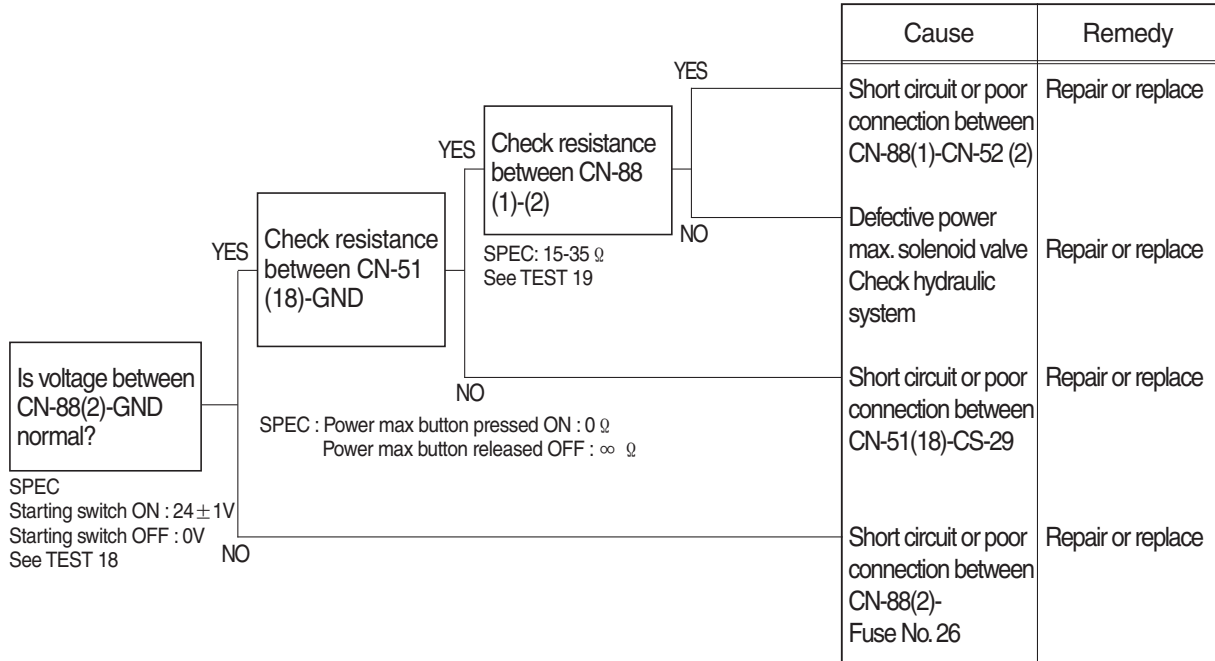

Wiring diagram

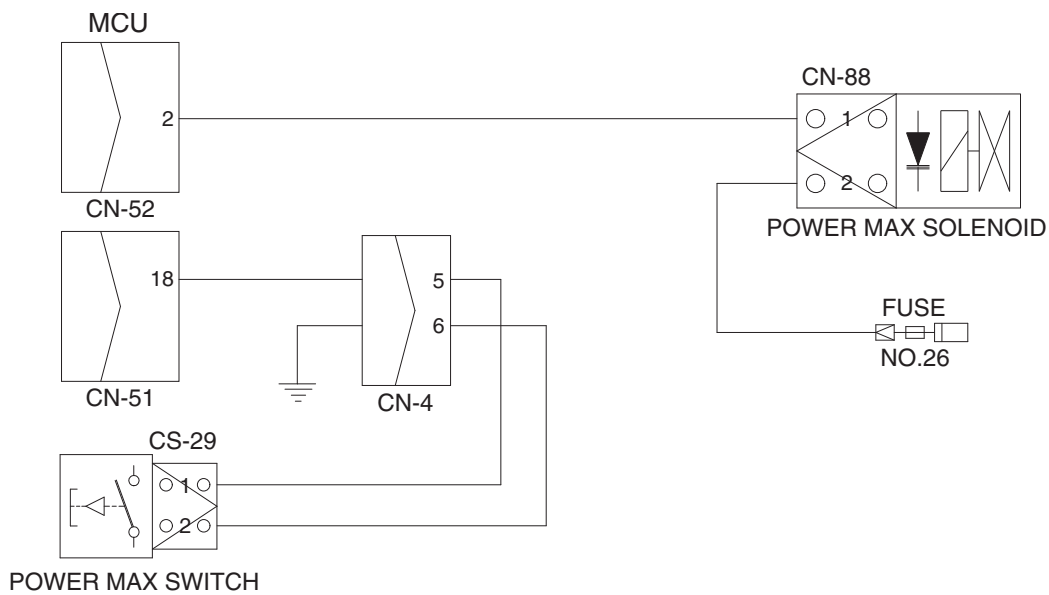

380L6MS04

2) TEST PROCEDURE

(1) **Test 18:** Check voltage between connector CN-88 (2) - GND.

- ① Disconnect connector CN-88 from power max solenoid valve.
- ② Starting switch ON.
- ③ Check voltage as figure.

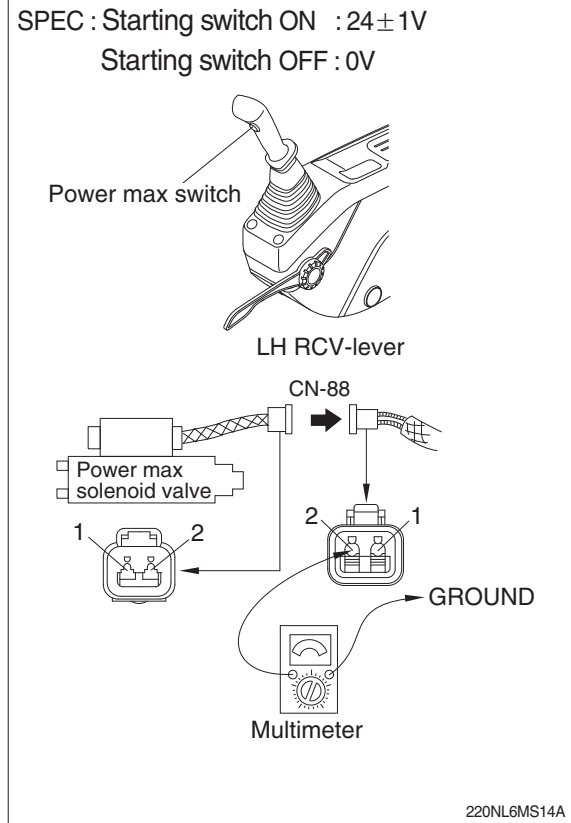

(2) **Test 19:** Check resistance of the solenoid valve between CN-88 (1)-(2).

- ① Starting switch OFF.
- ② Disconnect connector CN-88 from power max solenoid valve.
- ③ Check resistance as figure.

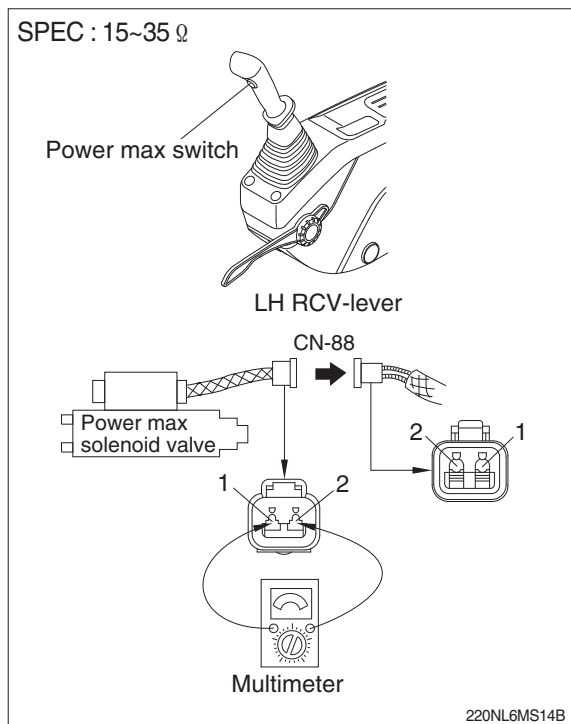

15. MALFUNCTION OF BOOM PRIORITY EPPR VALVE

· Fault code : HCESPN 141, FMI 5 or 6

※ Before carrying out below procedure, check all the related connectors are properly inserted.

1) INSPECTION PROCEDURE

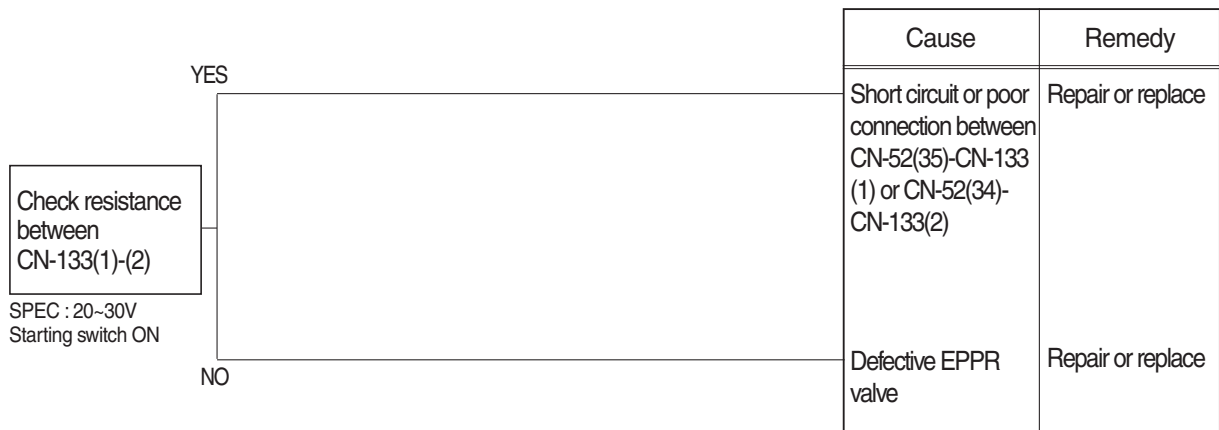

Wiring diagram

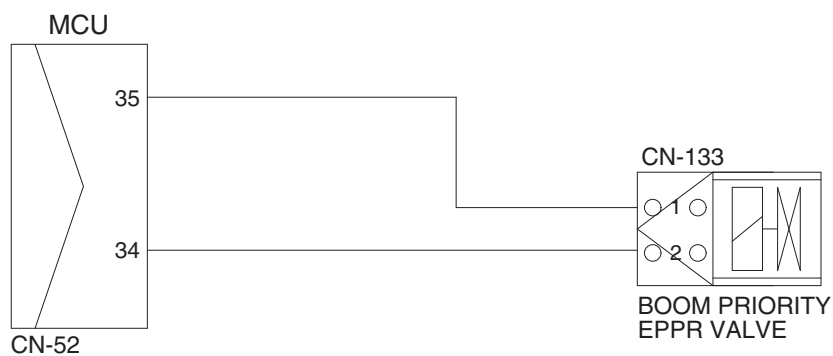

300L6MS23

16. MALFUNCTION OF ARM REGENERATION SOLENOID

· Fault code : HCESPN 170, FMI 4 or 6

※ Before carrying out below procedure, check all the related connectors are properly inserted.

1) INSPECTION PROCEDURE

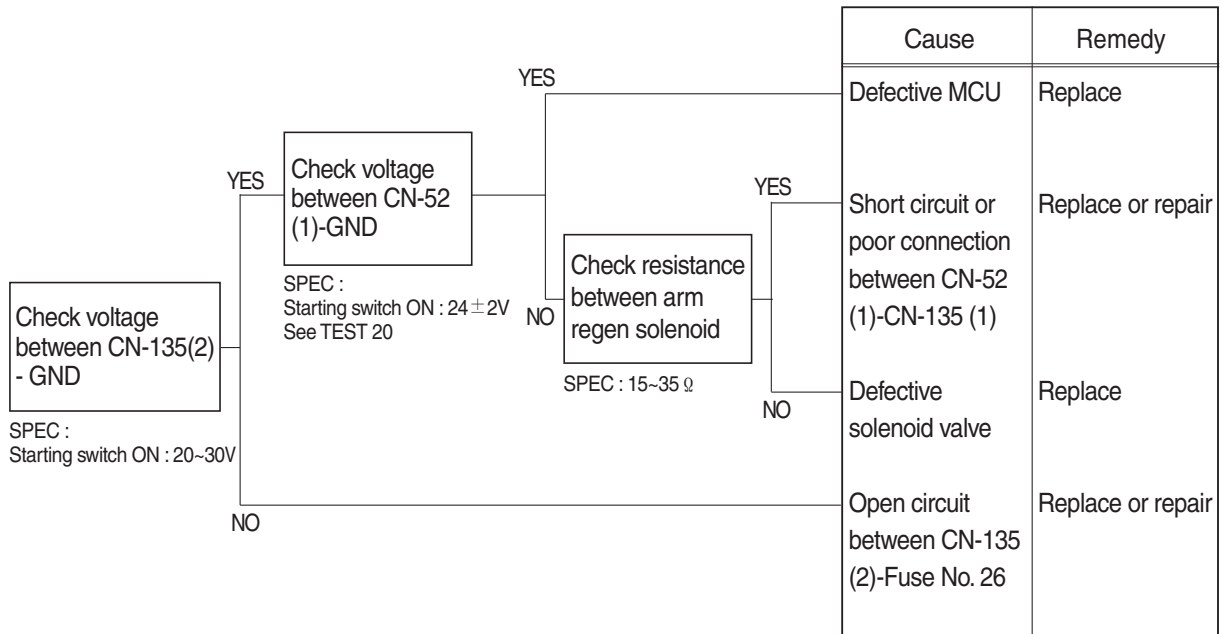

Wiring diagram

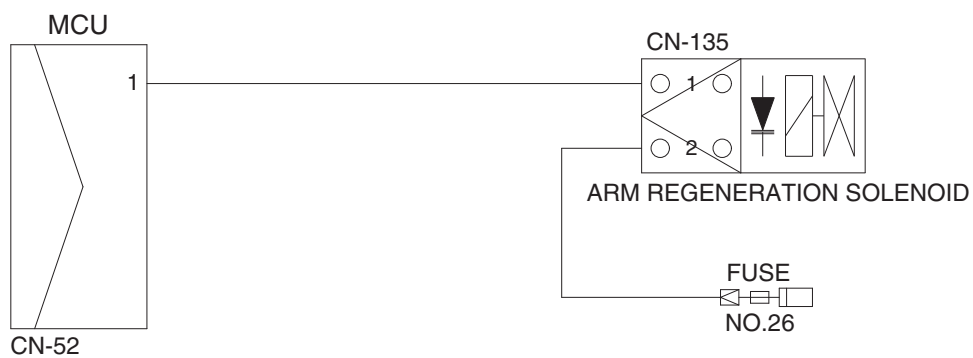

380L6MS05

2) TEST PROCEDURE

(1) **Test 20** : Check voltage at CN-52 (1) and ground.

- ① Prepare 1 piece of thin sharp pin, steel or copper.
- ② Insert prepared pin to rear side of connectors : One pin to (1) of CN-52.
- ③ Starting switch ON.
- ④ Check voltage as figure.

SPEC : Starting switch ON : 24 ± 2 V

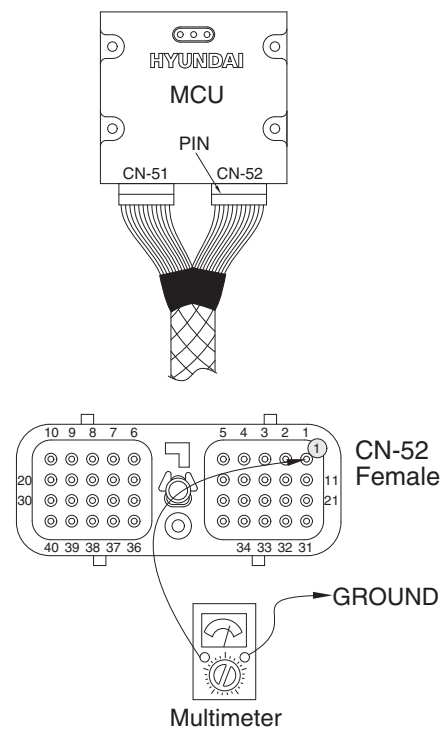

300L6MS22