

SECTION 4 ELECTRICAL SYSTEM

Group 1 Component Location	4-1
Group 2 Electrical Circuit	4-3
Group 3 Electrical Component Specification	4-23
Group 4 Connectors	4-34

SECTION 4 ELECTRICAL SYSTEM

GROUP 1 COMPONENT LOCATION

1. LOCATION 1

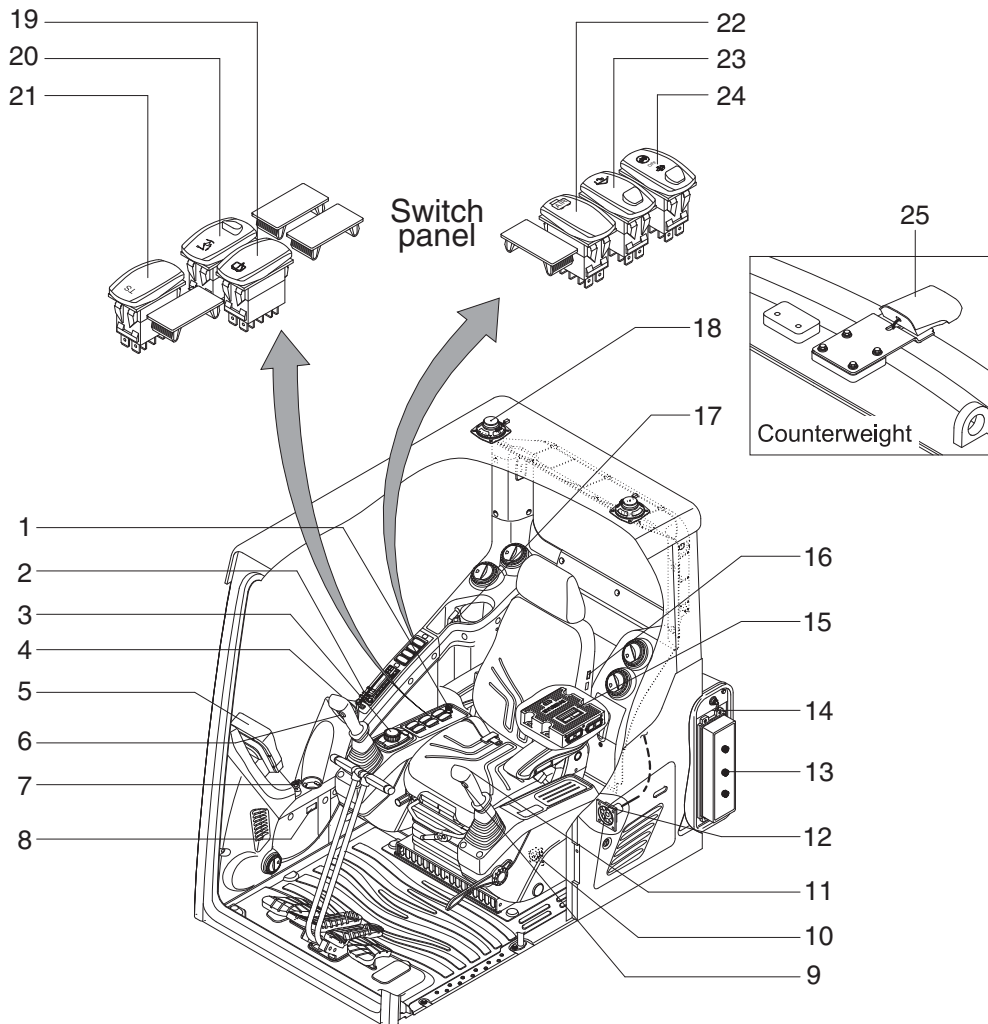

380L4EL15

- | | | |
|----------------------------|---------------------------------|--------------------------------|
| 1 Cigar lighter | 10 Emergency engine stop switch | 19 Lower wiper & washer switch |
| 2 Radio & USB player | 11 One touch decel switch | 20 Boom floating switch |
| 3 Haptic controller | 12 RS232 & J1939 service socket | 21 Travel straight switch |
| 4 Horn switch | 13 Fuse & relay box | 22 Air compressor switch |
| 5 Cluster | 14 Master switch | 23 Quick clamp switch |
| 6 Breaker operation switch | 15 Machine control unit | 24 DPF switch |
| 7 Starting switch | 16 Seat heater switch | 25 Rear view camera |
| 8 Service meter | 17 Service socket | |
| 9 Power max switch | 18 Speaker | |

2. LOCATION 2

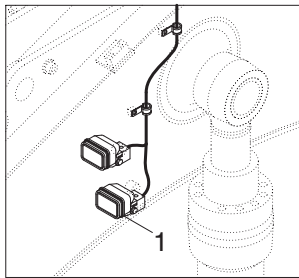

BOOM

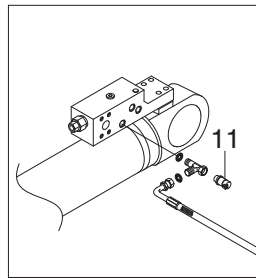

BOOM SAFETY VALVE

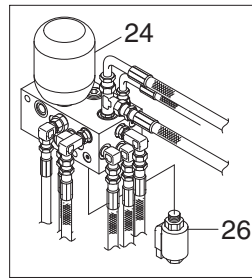

SOLENOID VALVE

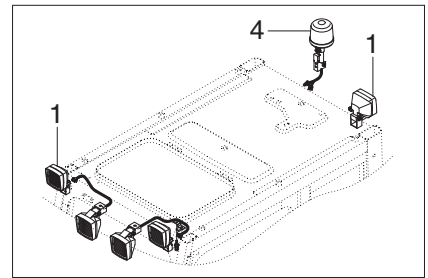

CAB

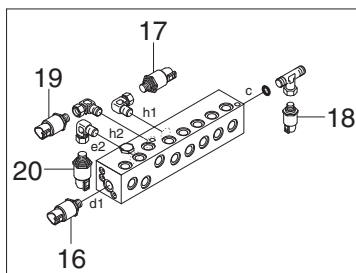
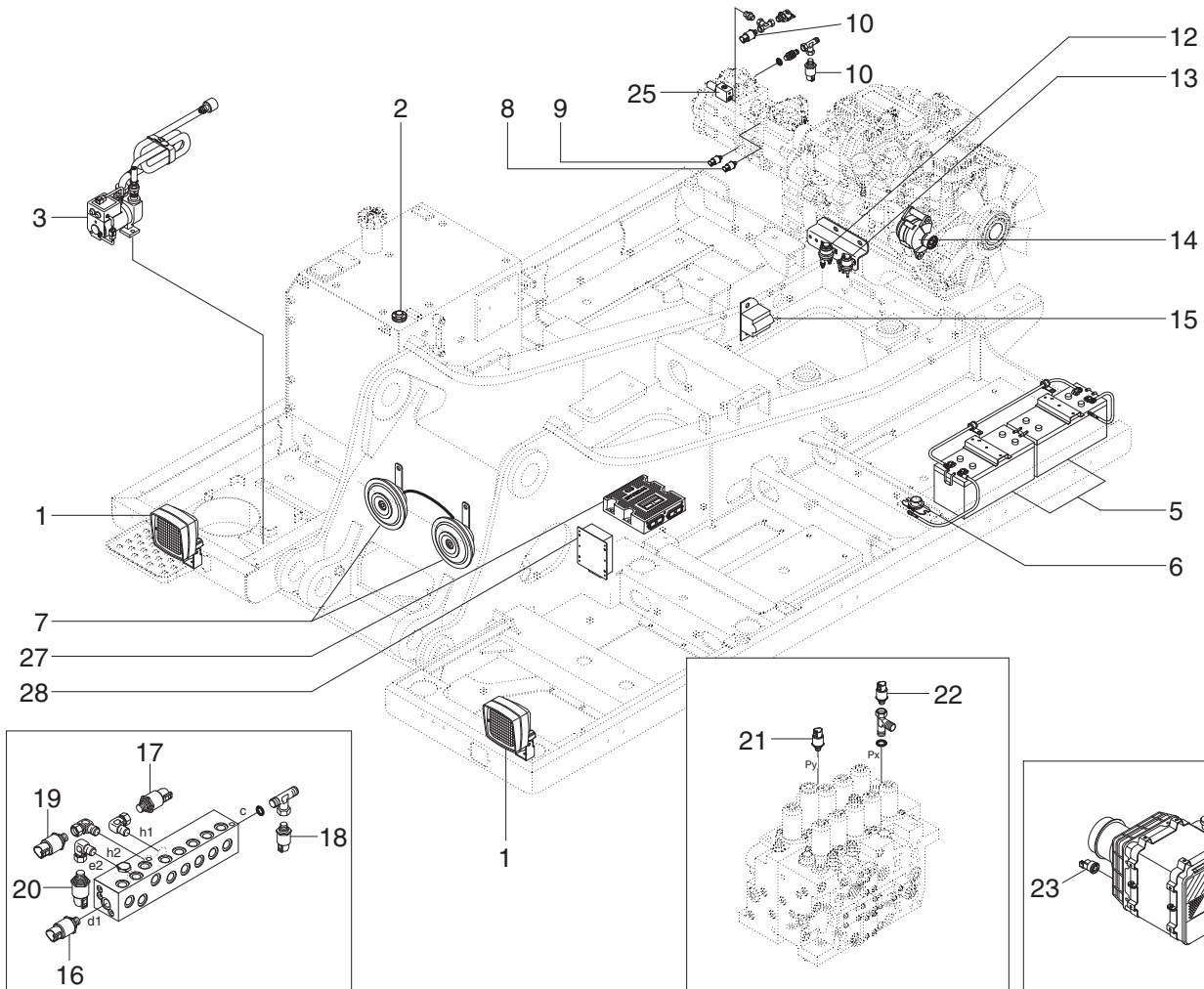

SHUTTLE BLOCK

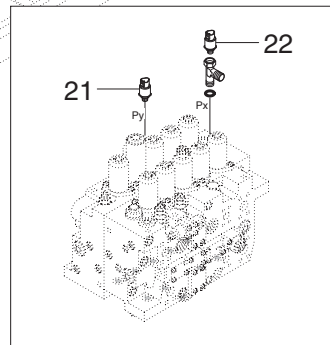

MAIN CONTROL VALVE

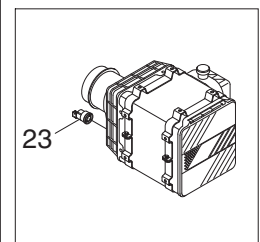

AIR CLEANER

380L4EL16

- | | | |
|-------------------------|----------------------------------|-----------------------------|
| 1 Lamp | 11 Overload pressure sensor | 21 Attach pressure sensor |
| 2 Fuel sender | 12 Start relay | 22 Travel pressure sensor |
| 3 Fuel filler pump | 13 Heater relay | 23 Air cleaner sensor |
| 4 Beacon lamp | 14 Alternator | 24 4 cartridge valve |
| 5 Battery | 15 Travel alarm buzzer | 25 Pump EPPR valve |
| 6 Battery relay | 16 Arm/Bucket in pressure sensor | 26 Boom priority EPPR valve |
| 7 Horn | 17 Boom up pressure sensor | 27 MCU 1 |
| 8 P1 pressure sensor | 18 Swing pressure sensor | 28 MCU 2 |
| 9 P2 pressure sensor | 19 Boom down pressure sensor | |
| 10 EPPR pressure sensor | 20 Arm in/swing pressure sensor | |

GROUP 2 ELECTRICAL CIRCUIT

ELECTRICAL CIRCUIT (1/6, SERIAL NO. : #0261)

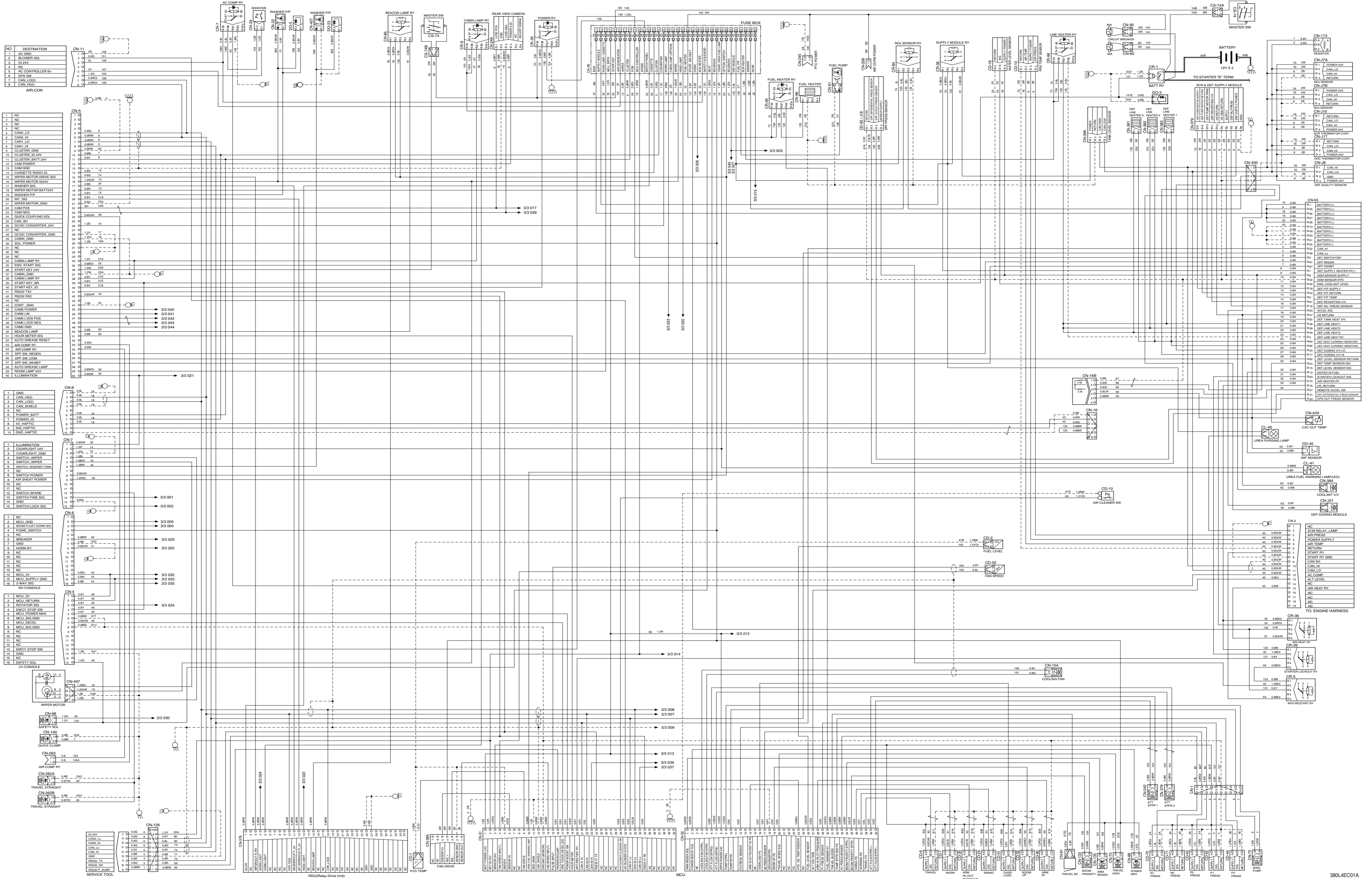

ELECTRICAL CIRCUIT (2/6, SERIAL NO. : -#0261)

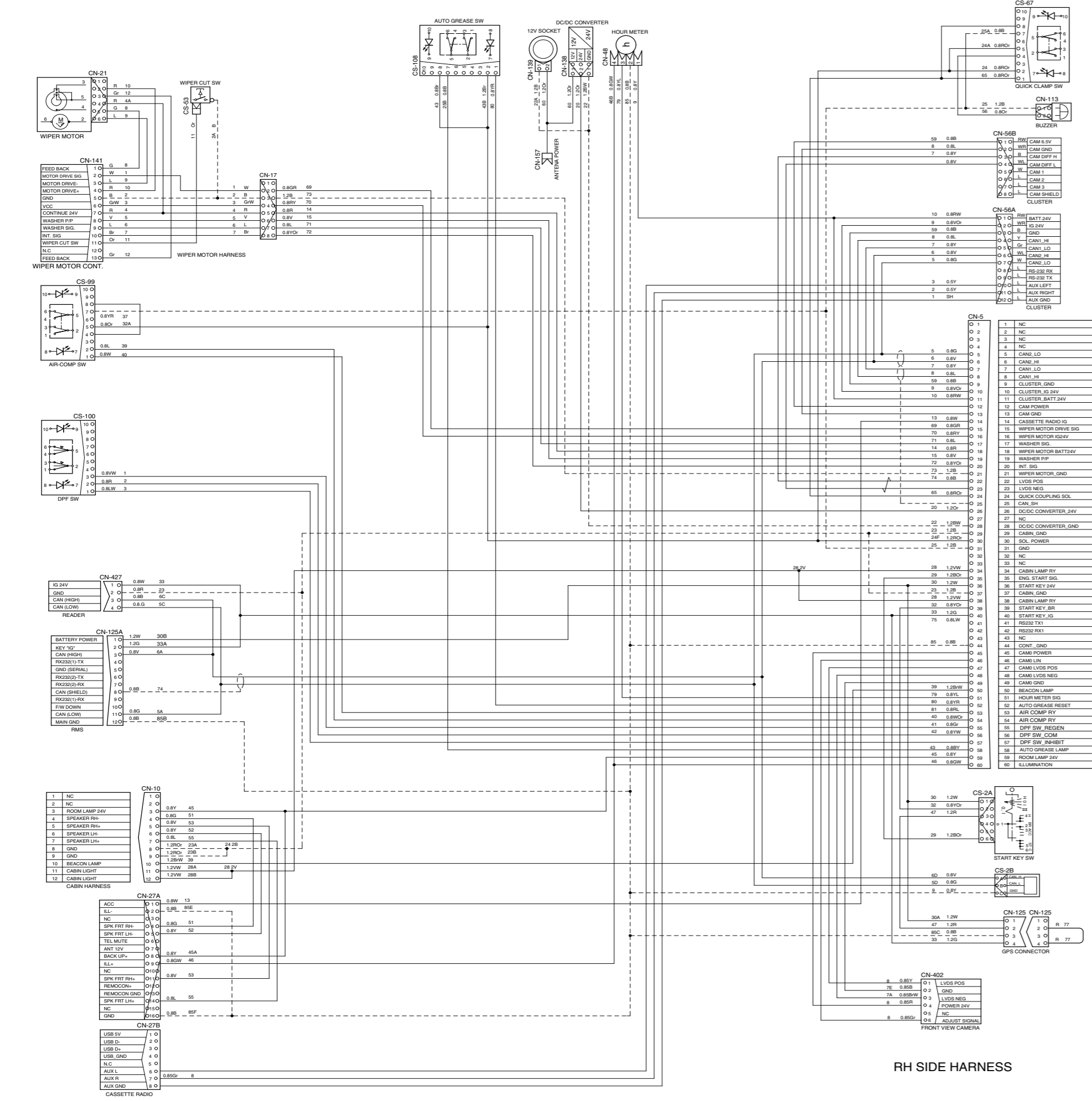

RH SIDE HARNESS

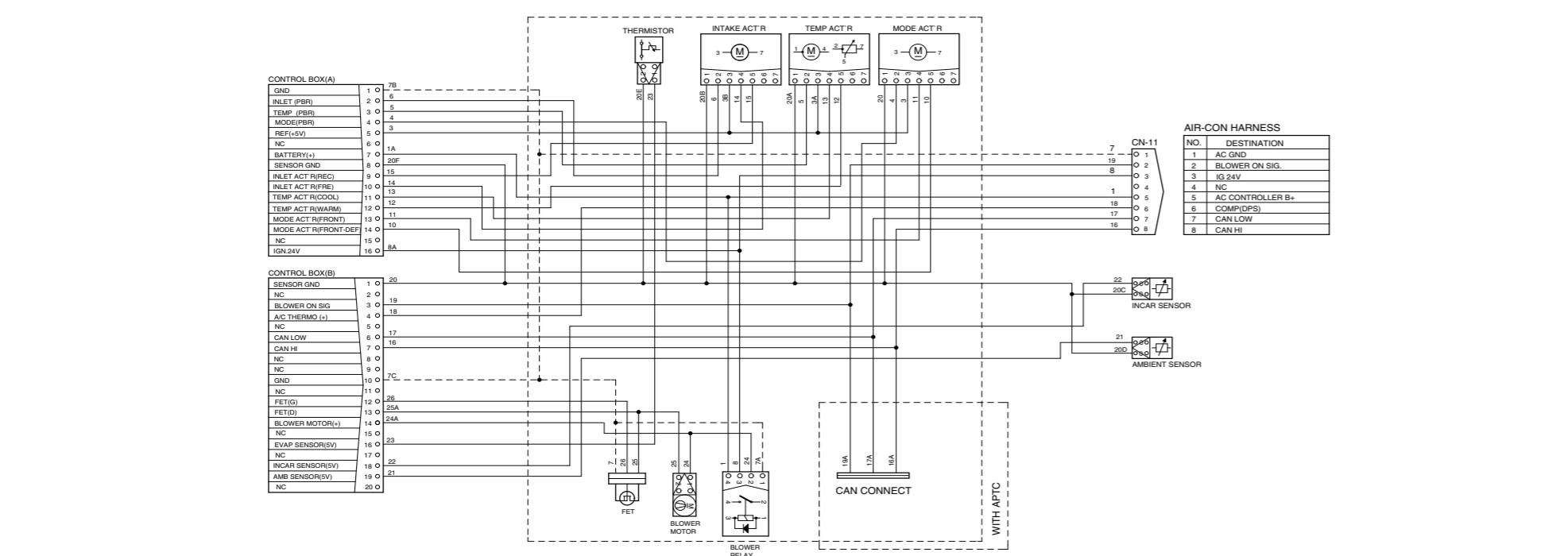

AIR-CON HARNESS

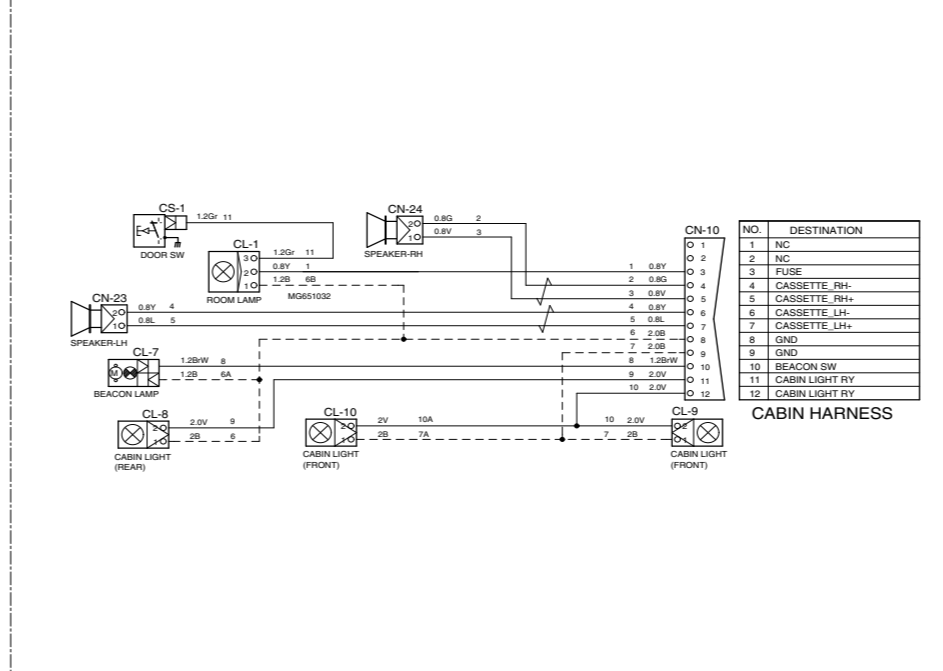

CABIN HARNESS

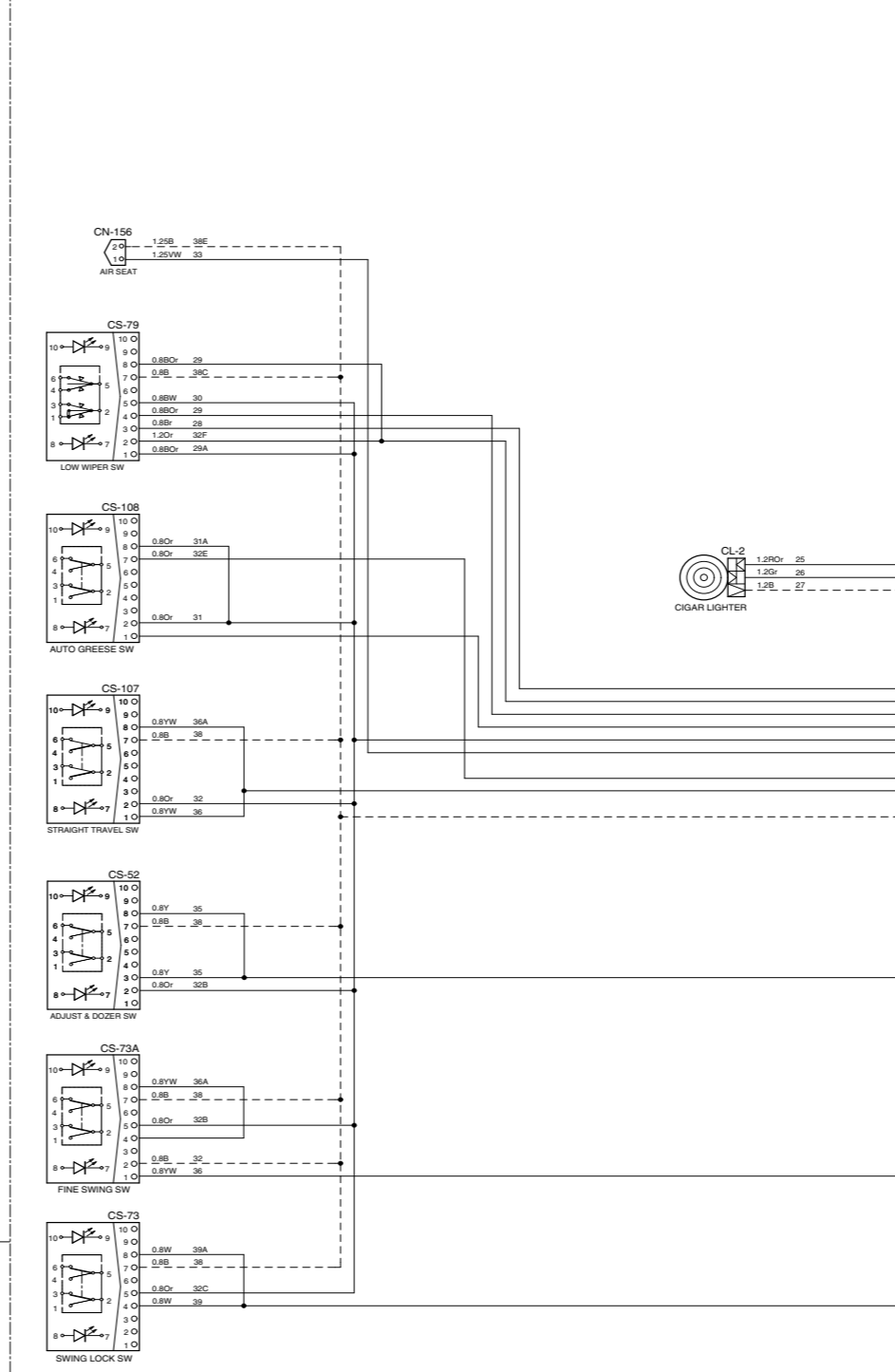

RH CONSOLE HARNESS

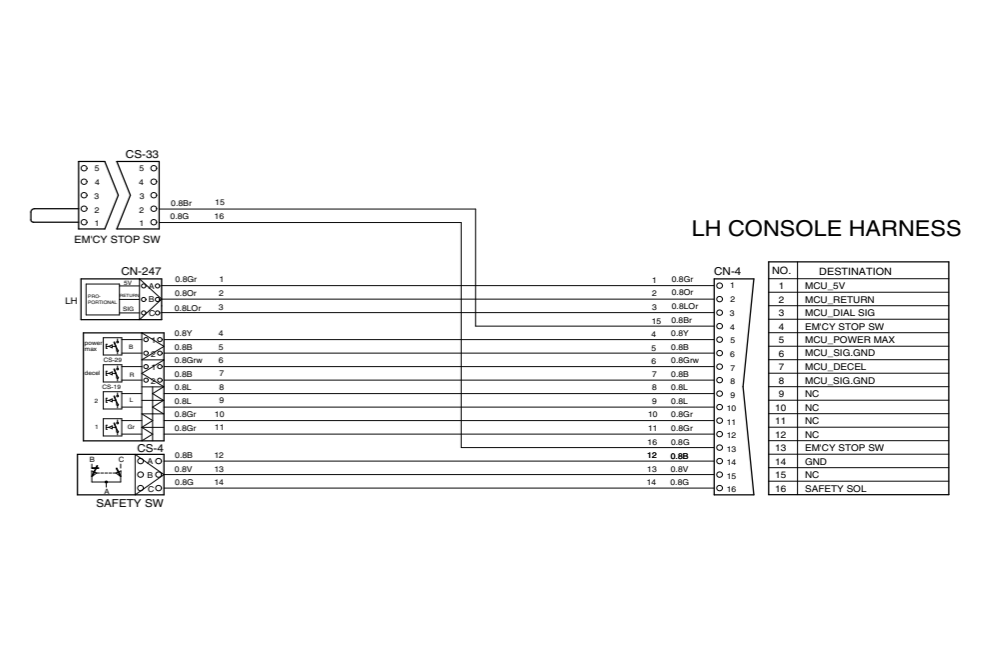

LH CONSOLE HARNESS

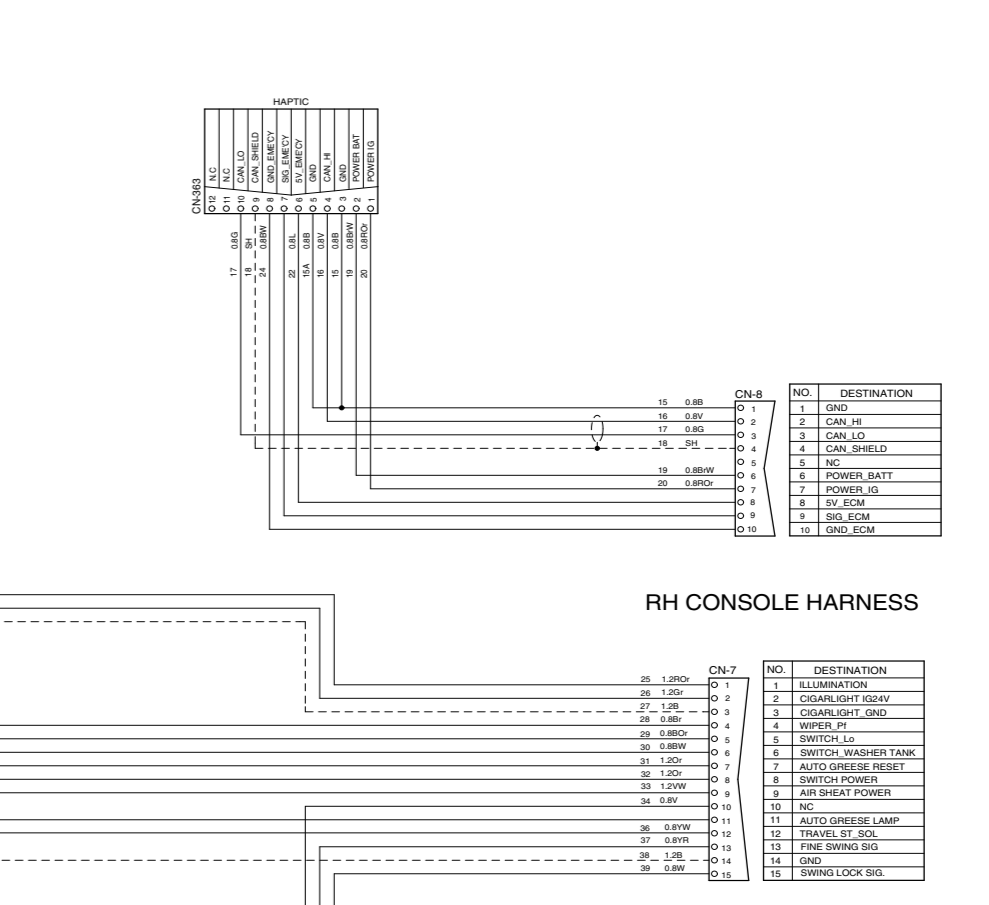

RH CONSOLE HARNESS

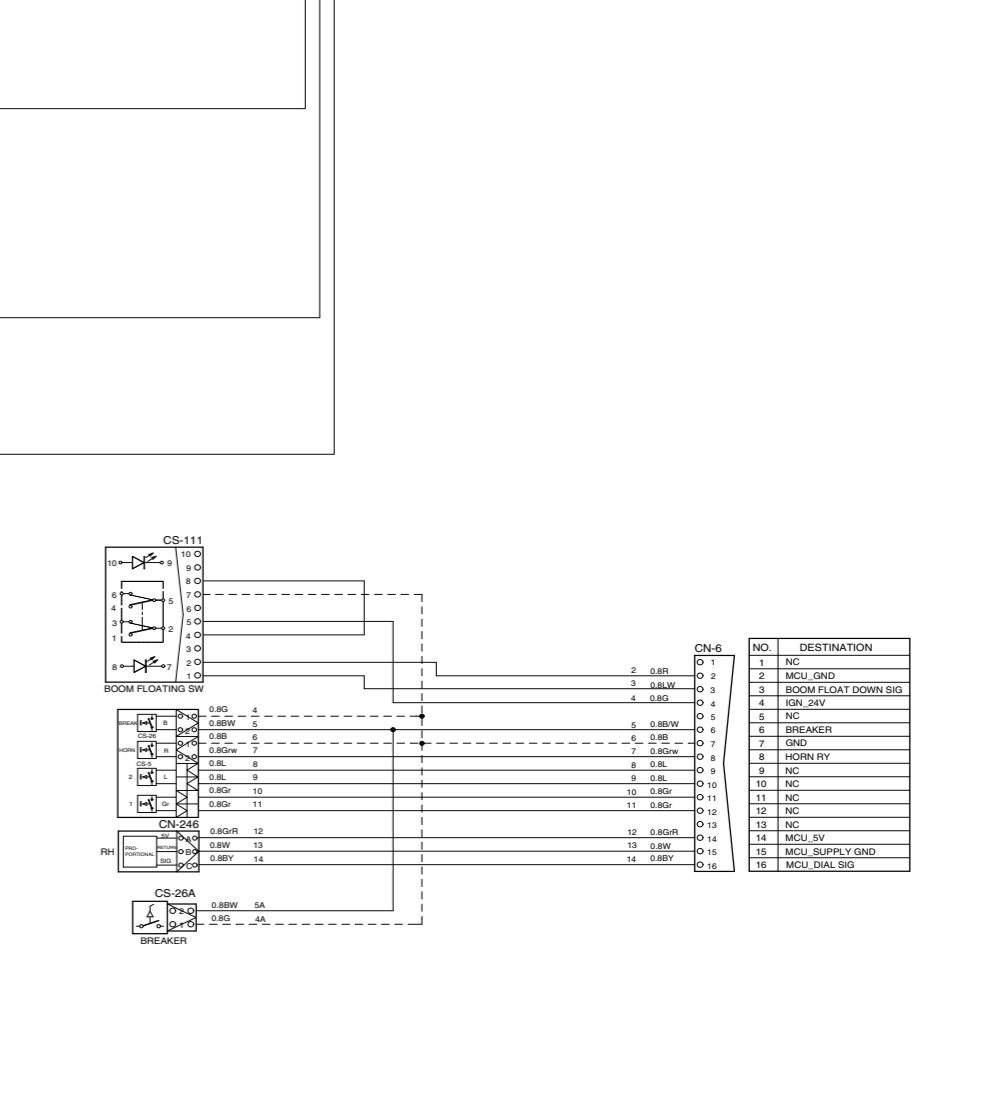

ROOM FLOATING SW

ELECTRICAL CIRCUIT (3/6, SERIAL NO. : -#0261)

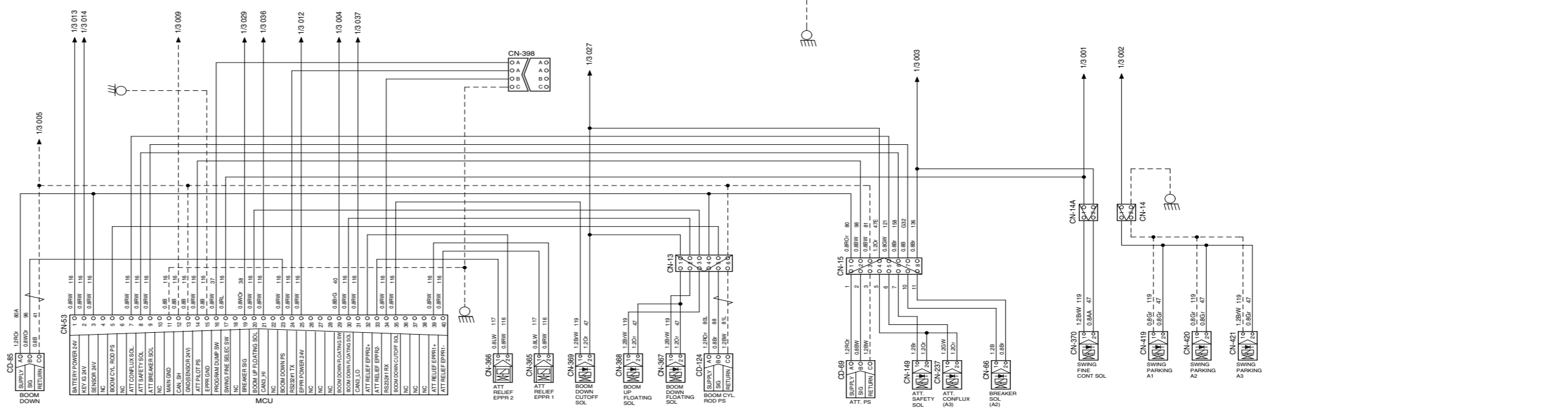
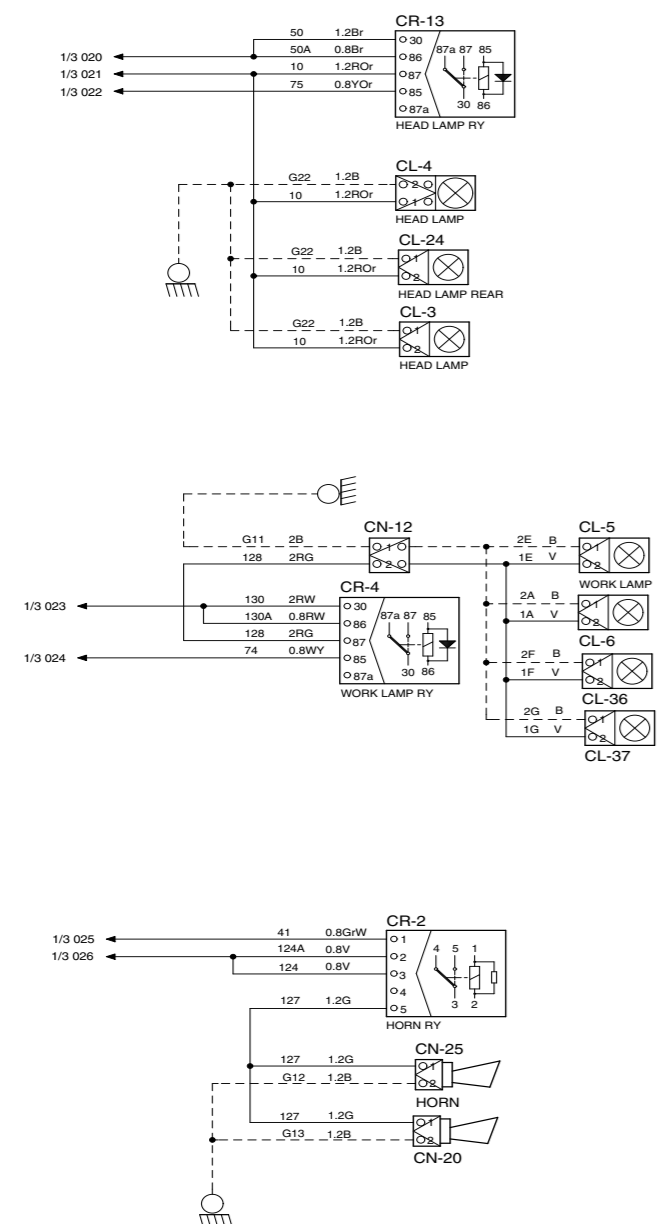
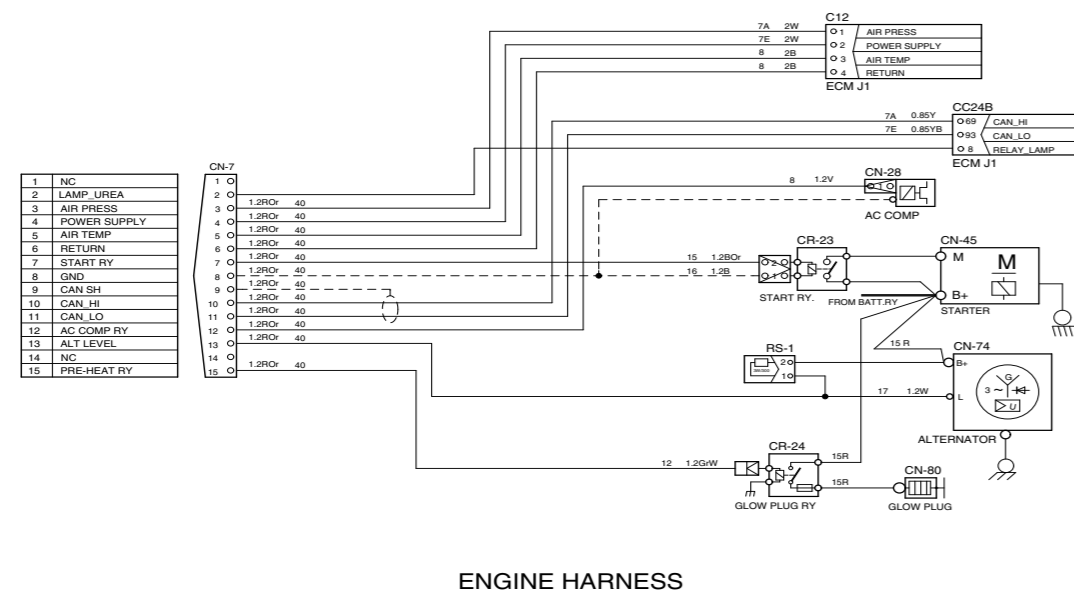

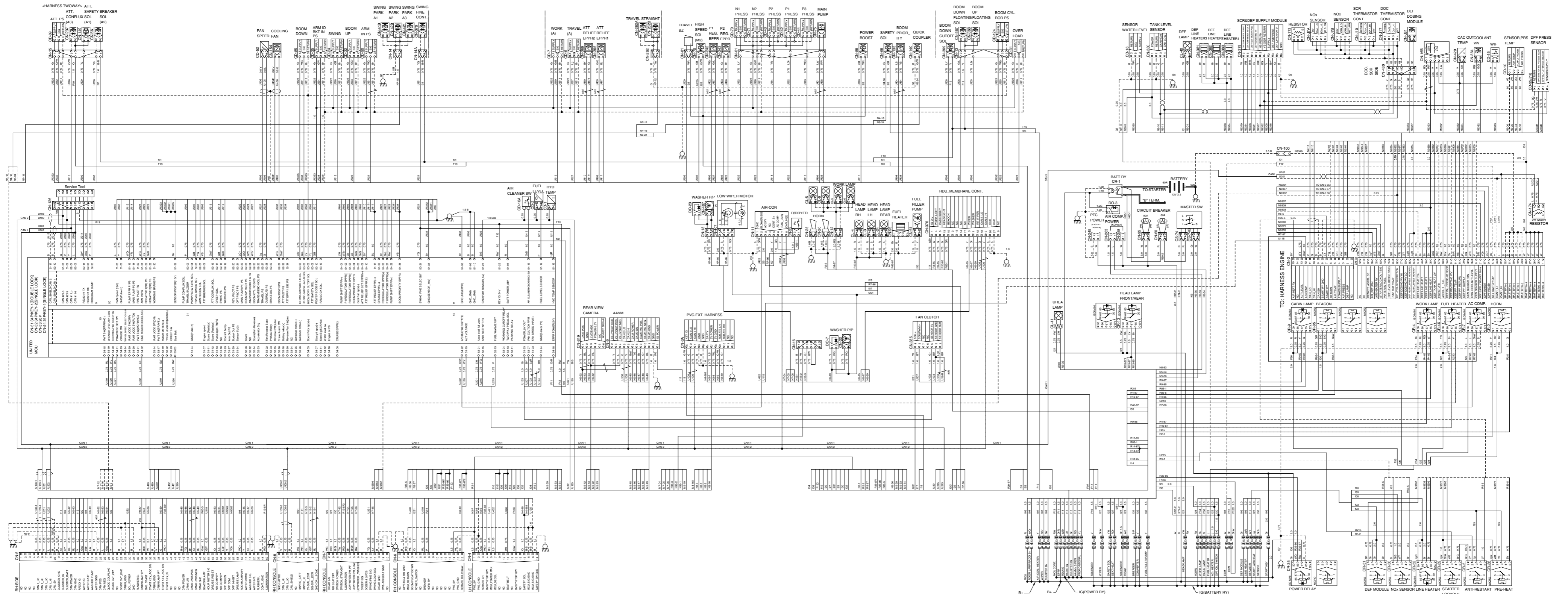

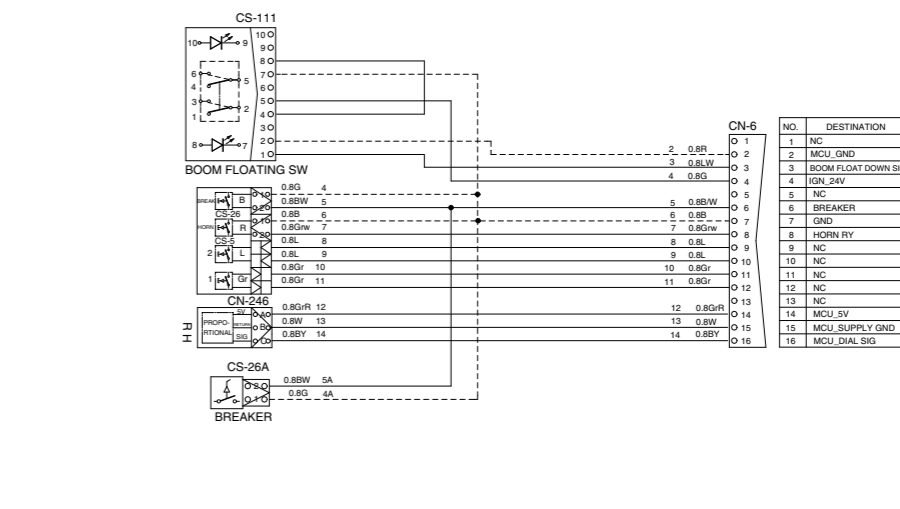
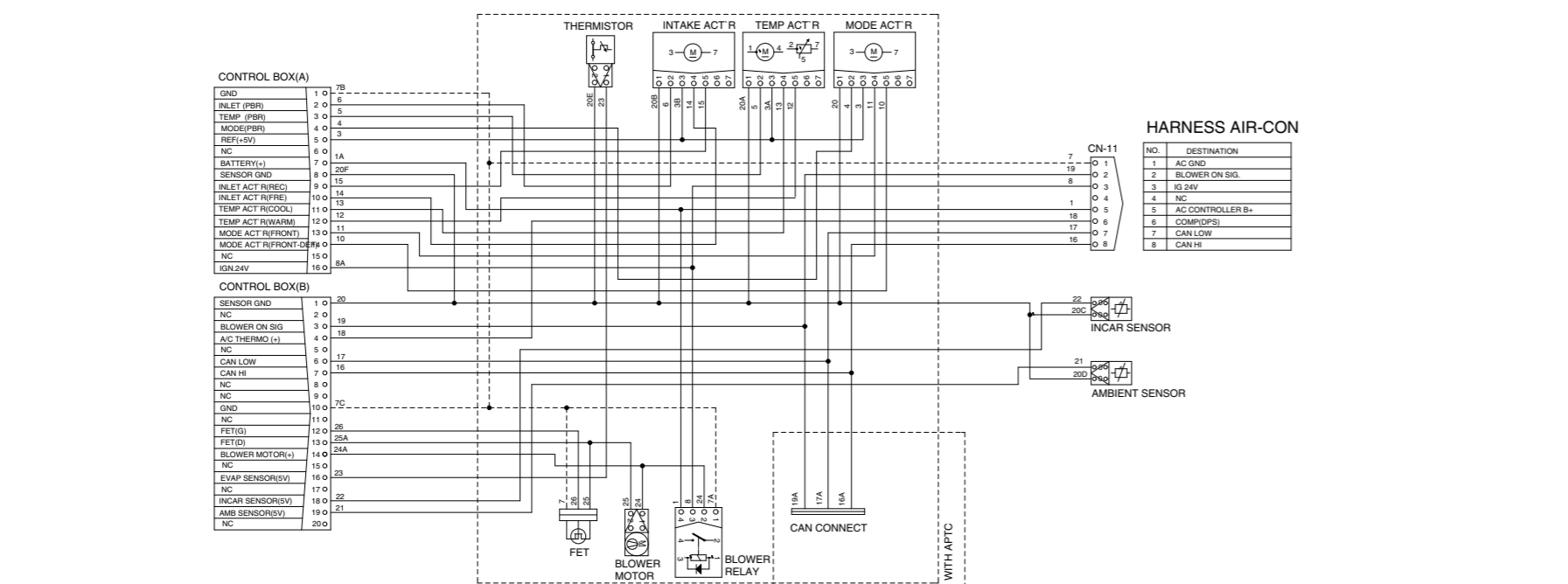
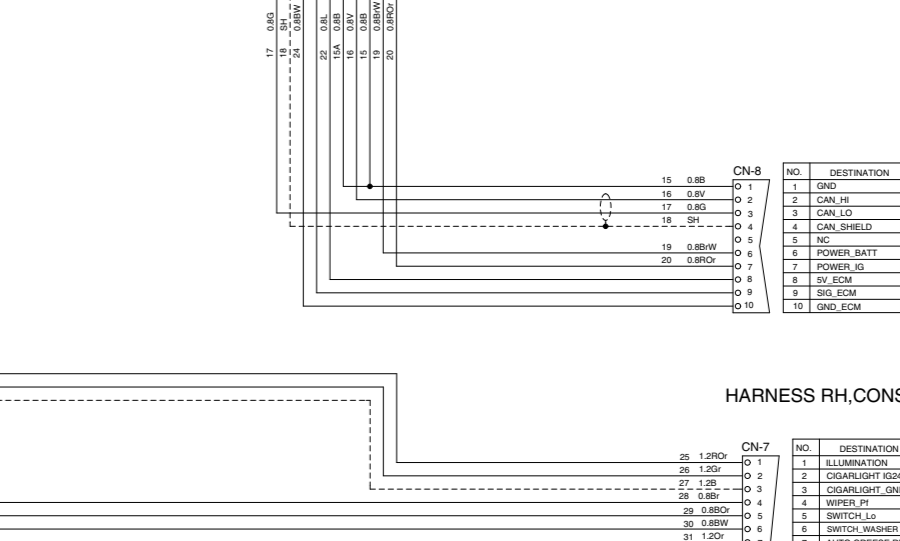
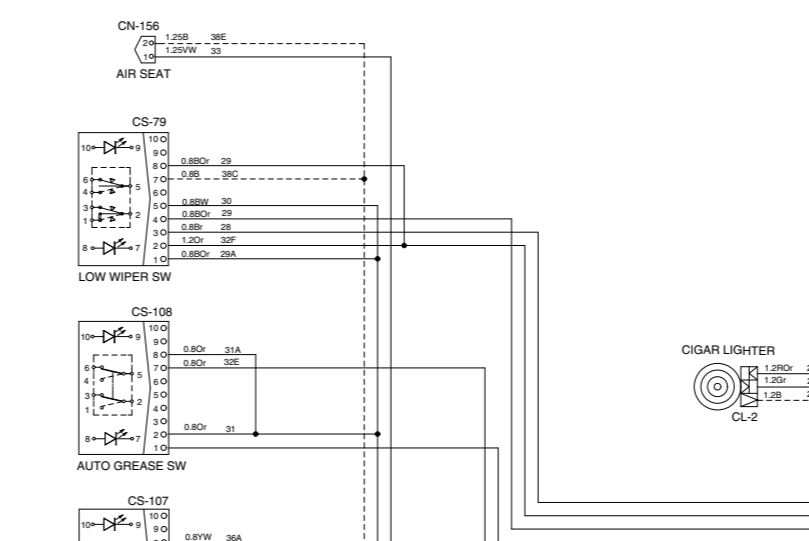
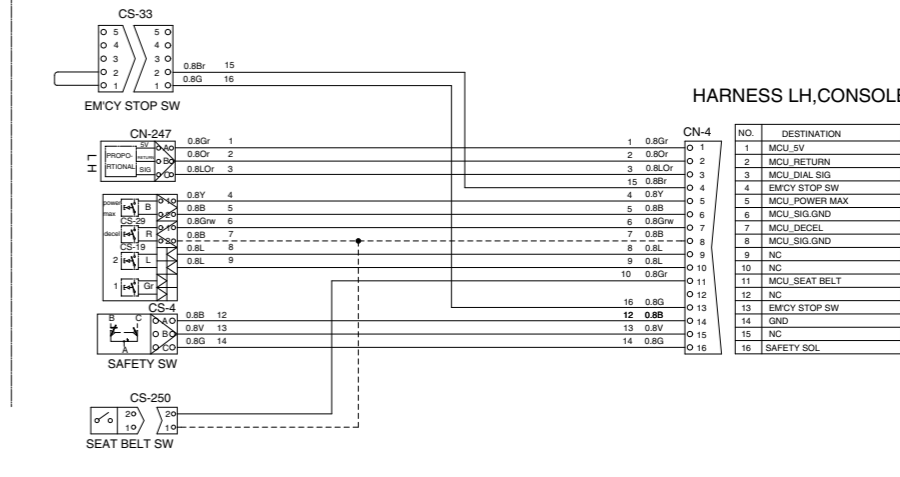
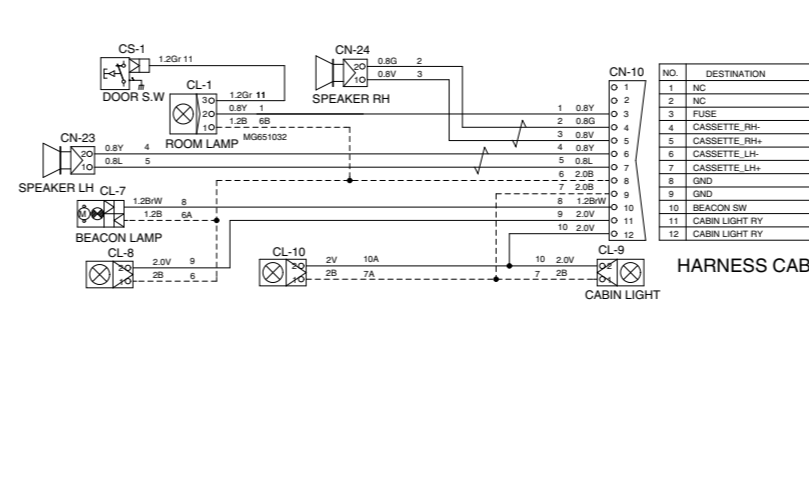
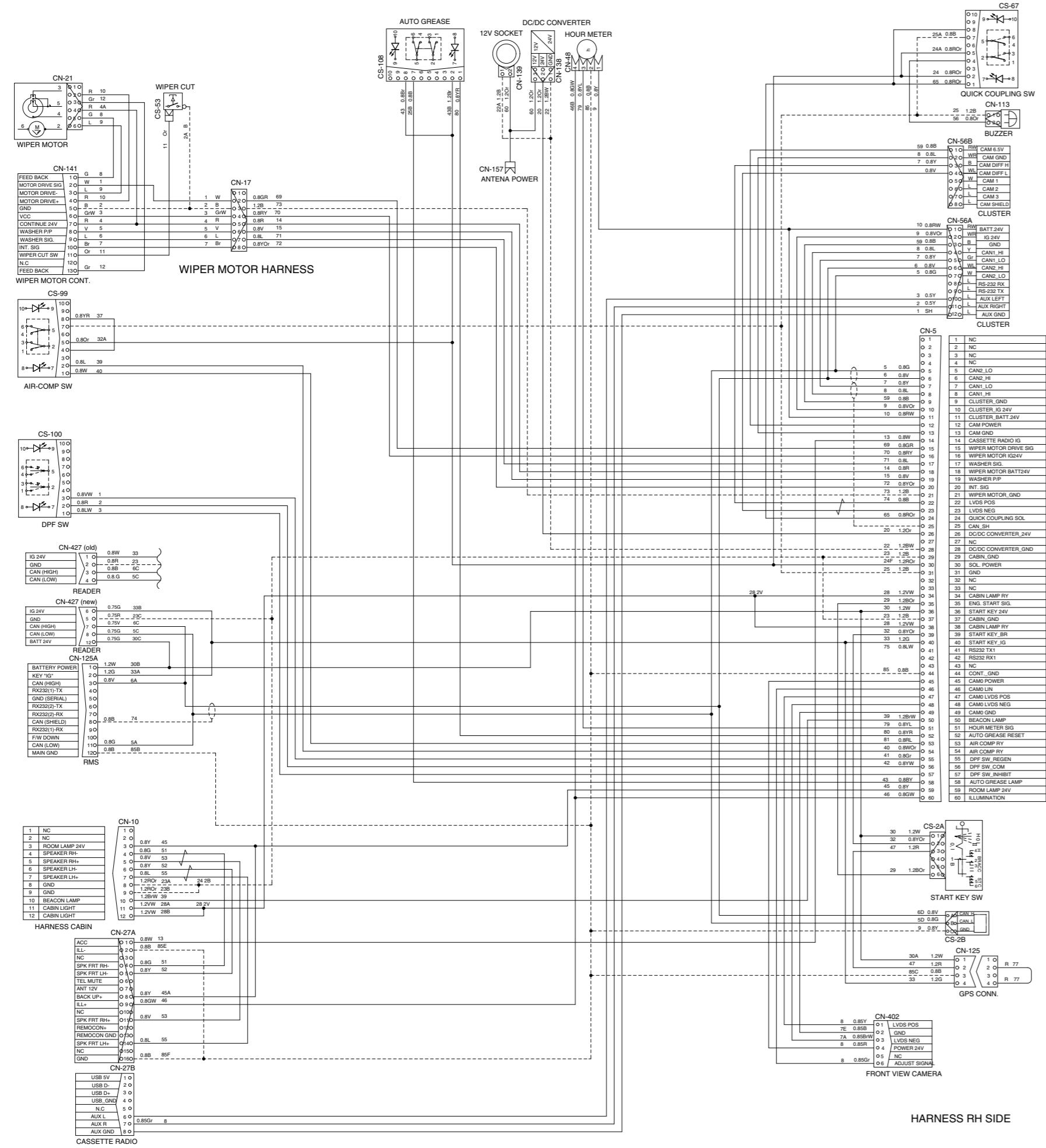

ELECTRICAL CIRCUIT (6/6, SERIAL NO. : #0262-)

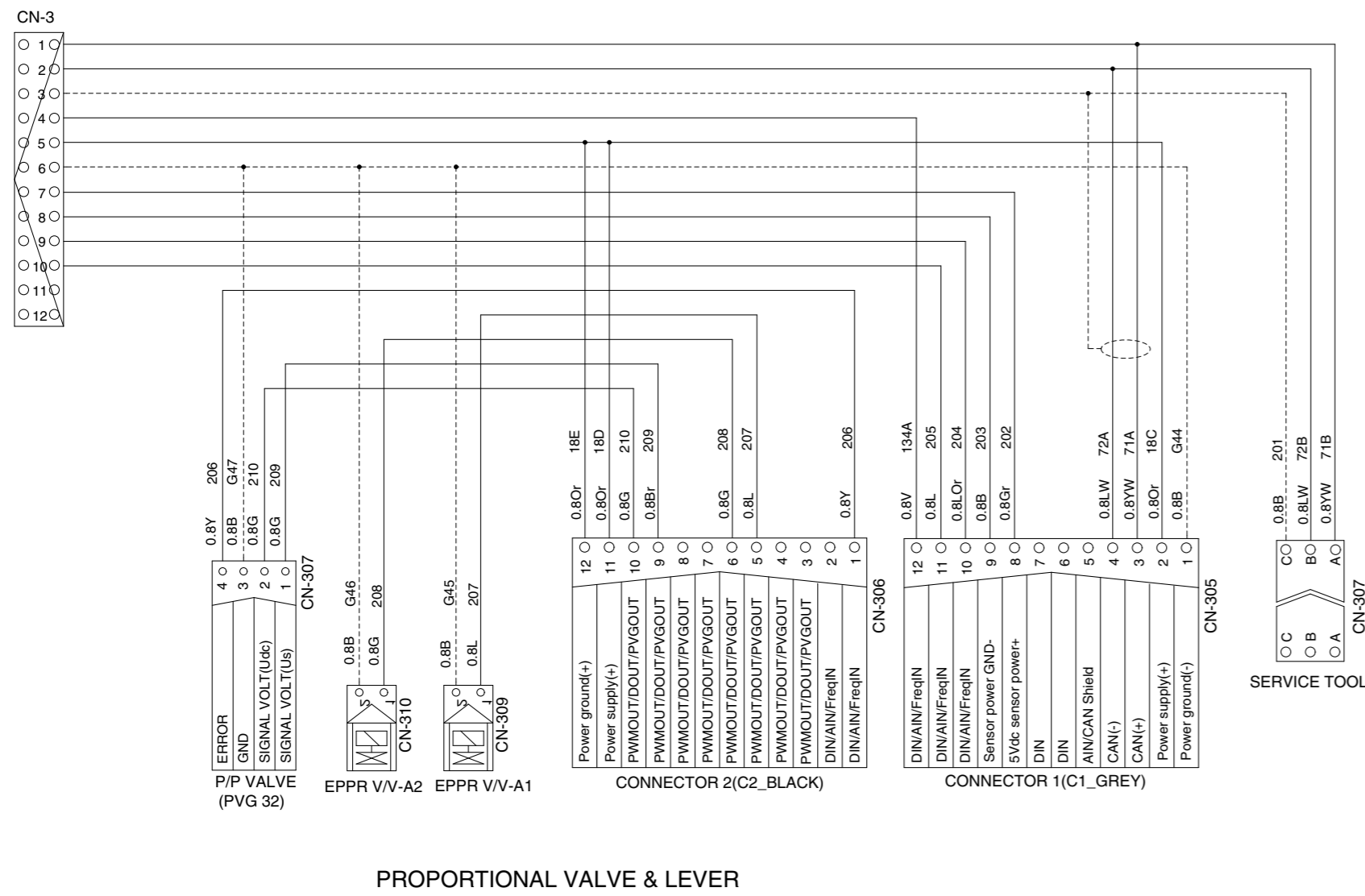
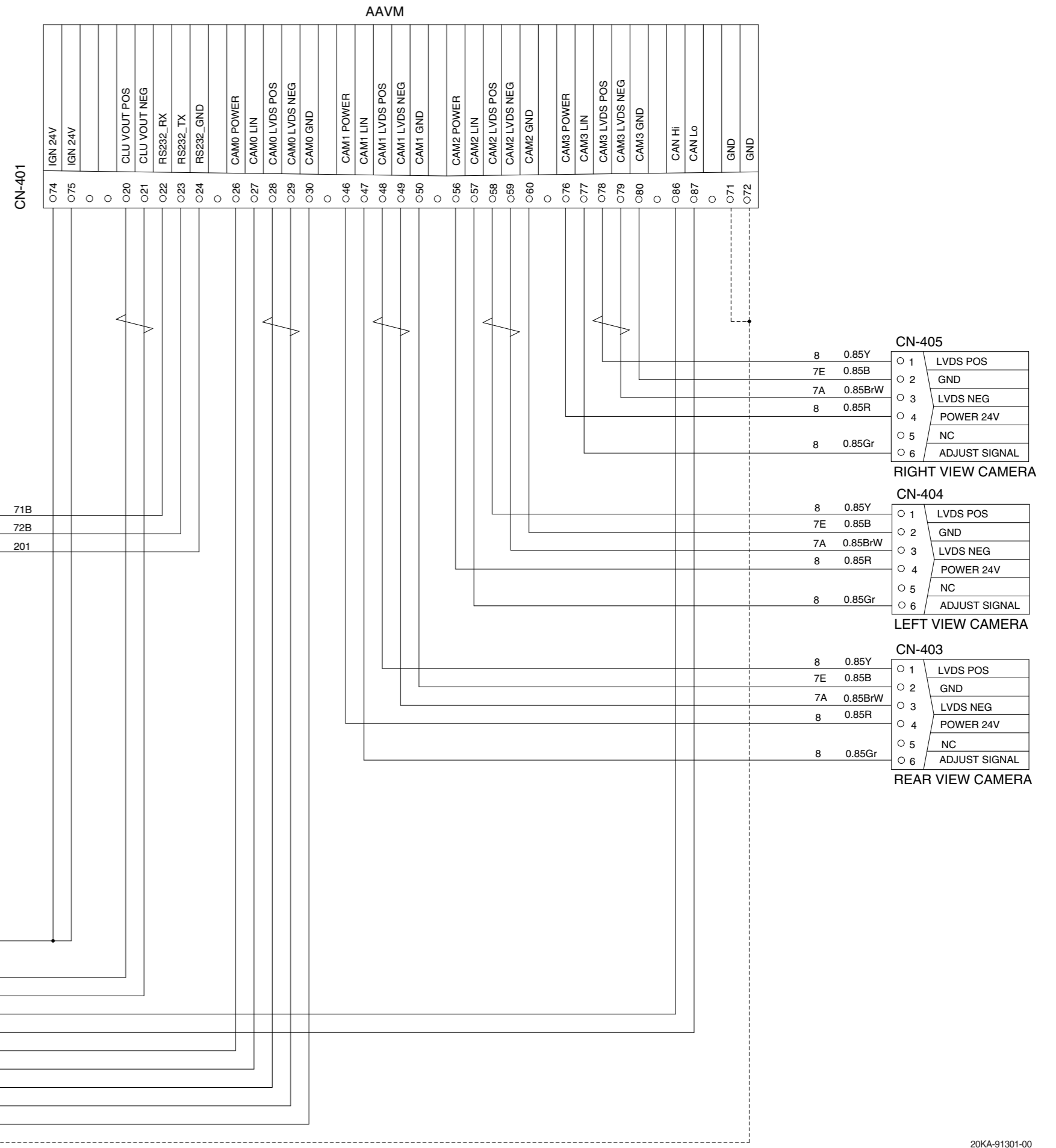
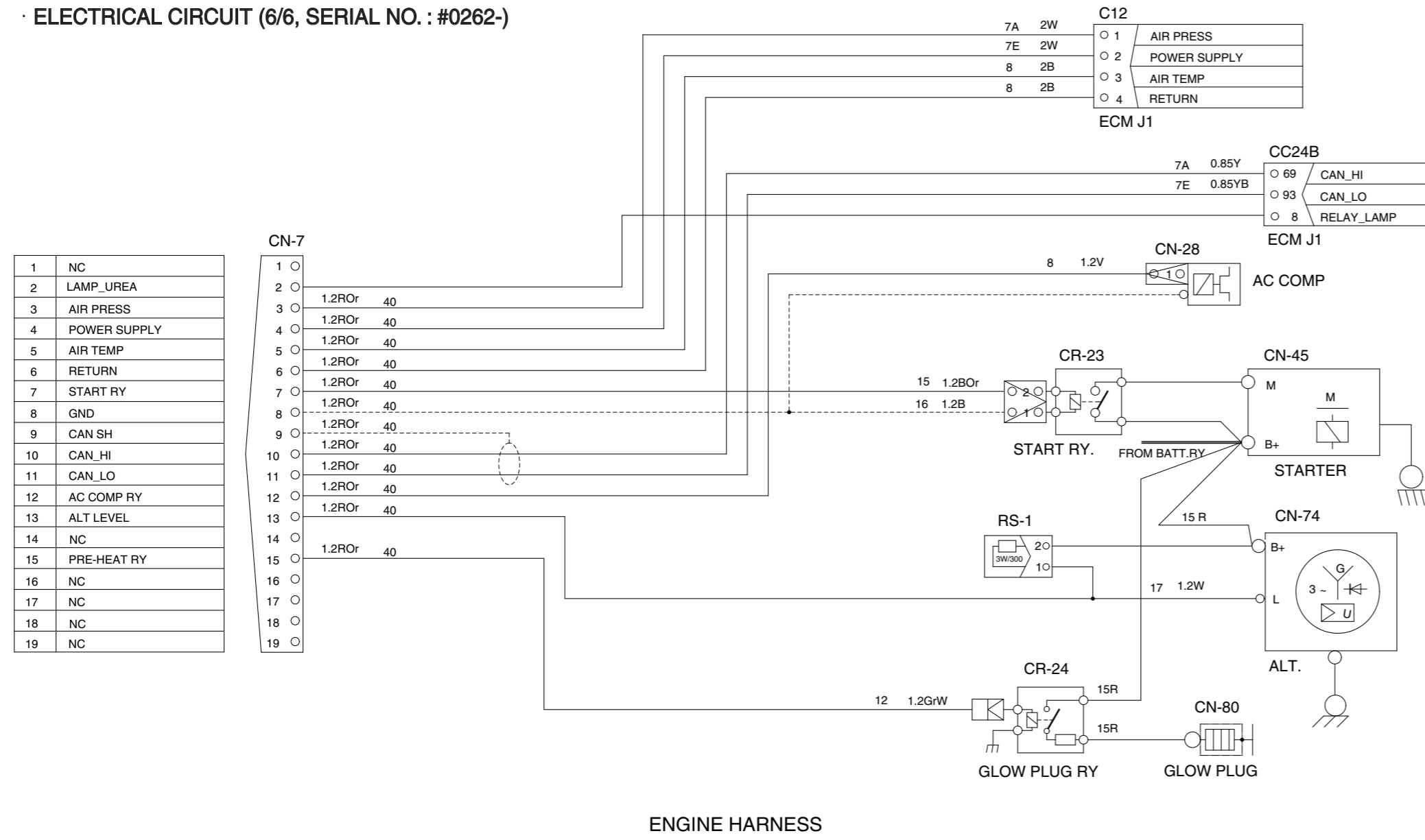

MEMORANDUM

1. POWER CIRCUIT

The negative terminal of battery is grounded to the machine chassis.

When the start switch is in the OFF position, the current flows from the positive battery terminal as shown below.

1) OPERATING FLOW

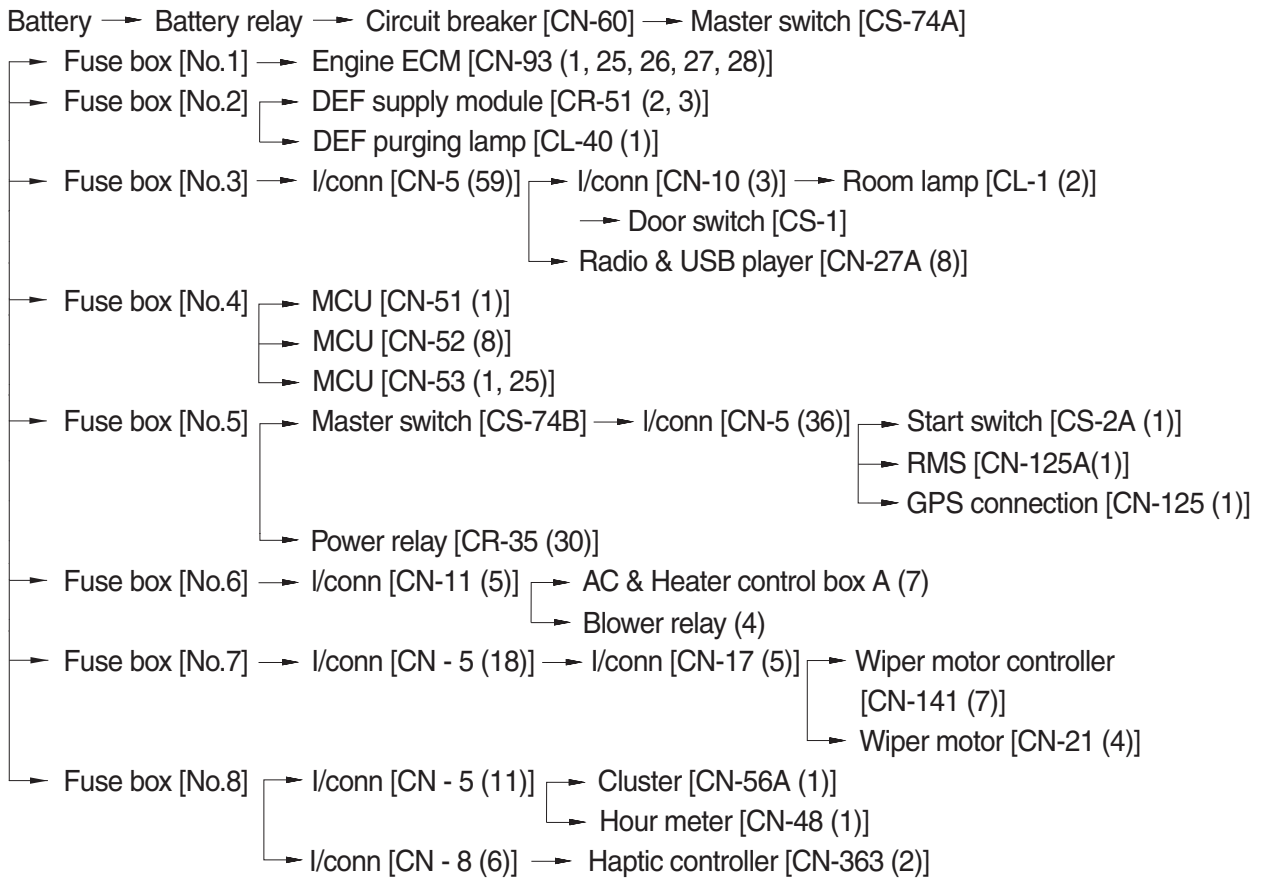

※ I/conn : Intermediate connector

2) CHECK POINT

Engine	Start switch	Check point	Voltage
OFF	OFF	① - GND (battery 1EA)	10~12.5V
		② - GND (battery 2EA)	20~25V
		③ - GND (battery relay 2EA)	20~25V
		④ - GND (circuit breaker)	20~25V

※ GND : Ground

POWER CIRCUIT

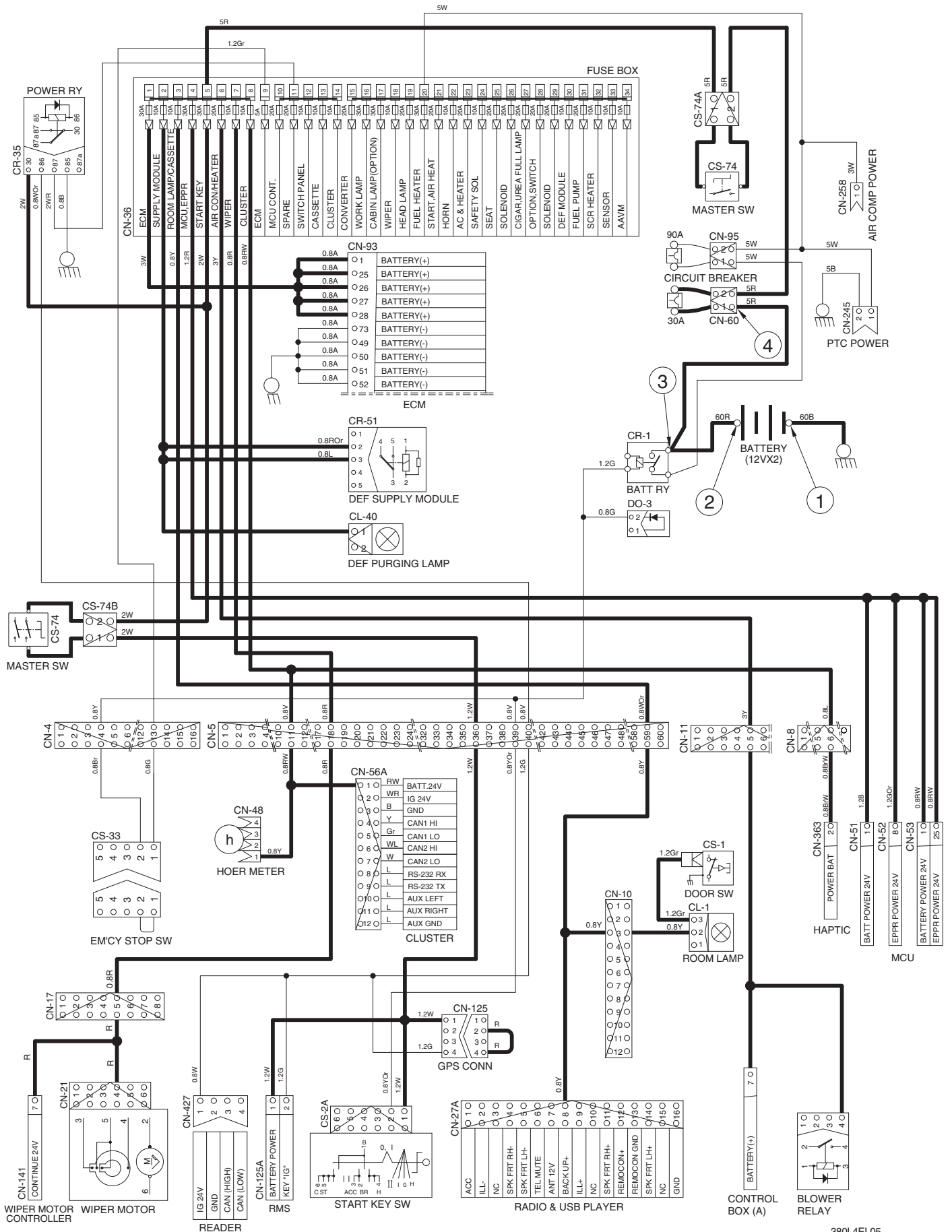

380L4EL05

2. STARTING CIRCUIT

1) OPERATING FLOW

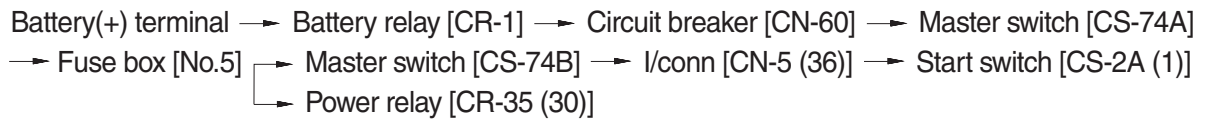

(1) When start key switch is in ON position

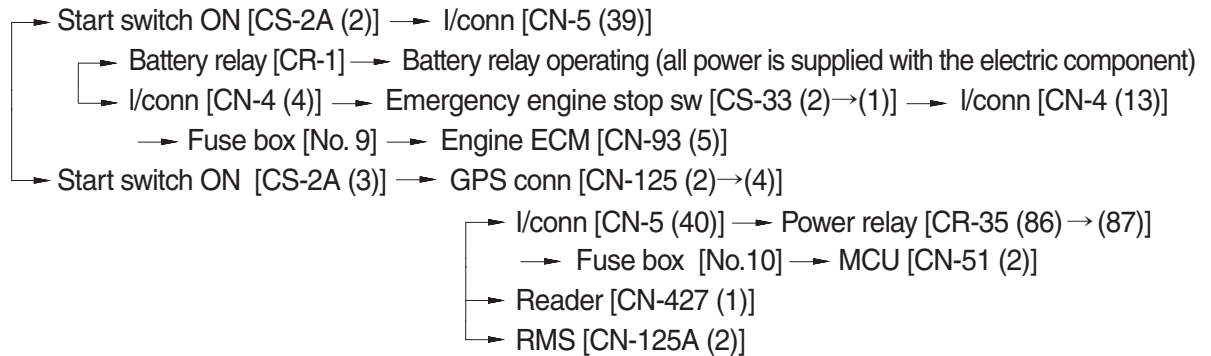

(2) When start key switch is in START position

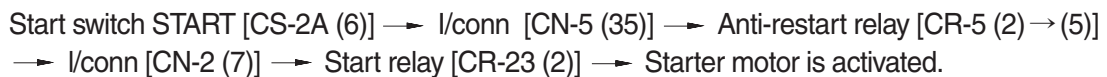

2) CHECK POINT

Engine	Start switch	Check point	Voltage
OPERATING	START	① - GND (battery) ② - GND (start key) ③ - GND (battery relay M4) ④ - GND (starter B ⁺) ⑤ - GND (starter M) ⑥ - GND (start relay) ⑦ - GND (battery relay M8)	20~25V

STARTING CIRCUIT

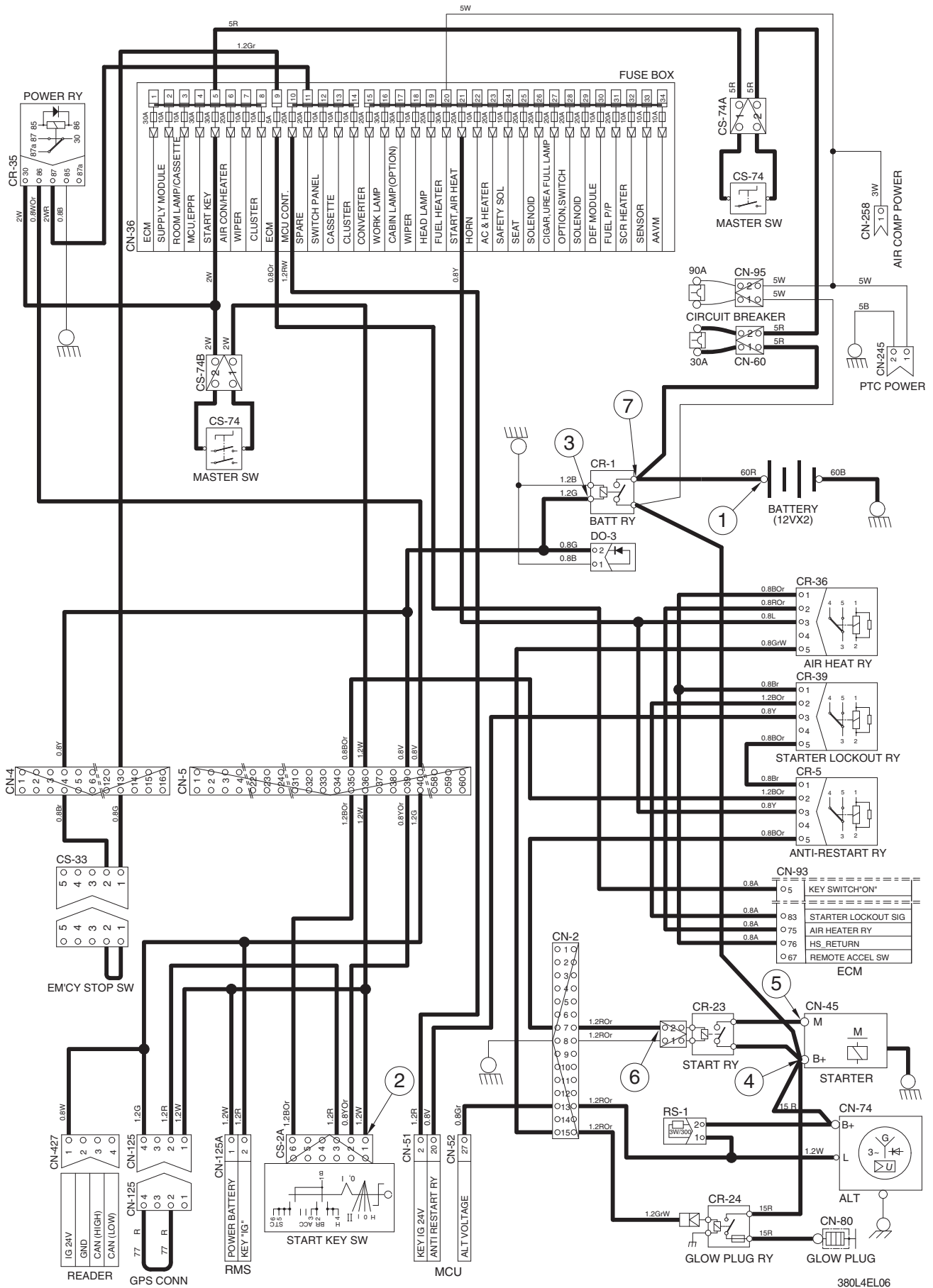

3. CHARGING CIRCUIT

When the starter is activated and the engine is started, the operator releases the key switch to the ON position.

Charging current generated by operating alternator flows into the battery through the battery relay [CR-1].

The current also flows from alternator to each electrical component and controller through the fuse box.

1) OPERATING FLOW

(1) Warning flow

Alternator "L" terminal → I/conn [CN-2 (13)] → MCU alternator voltage [CN-52 (27)]
 → Cluster charging warning lamp (via CAN interface)

(2) Charging flow

Alternator "B+" terminal → Starter [CN-45 (B+)] → Battery relay
 → Battery (+) terminal
 → Circuit breaker [CN-60] → Master switch [CS-74A]
 → Fuse box [No. 1~8]
 → Circuit breaker [CN-95] → Fuse box [No. 15~34]

2) CHECK POINT

Engine	Start switch	Check point	Voltage
Run	ON	① - GND (battery voltage) ② - GND (battery relay) ③ - GND (alternator B ⁺ terminal) ④ - GND (alternator L terminal) ⑤ - GND (MCU)	20~25V

※ GND : Ground

CHARGING CIRCUIT

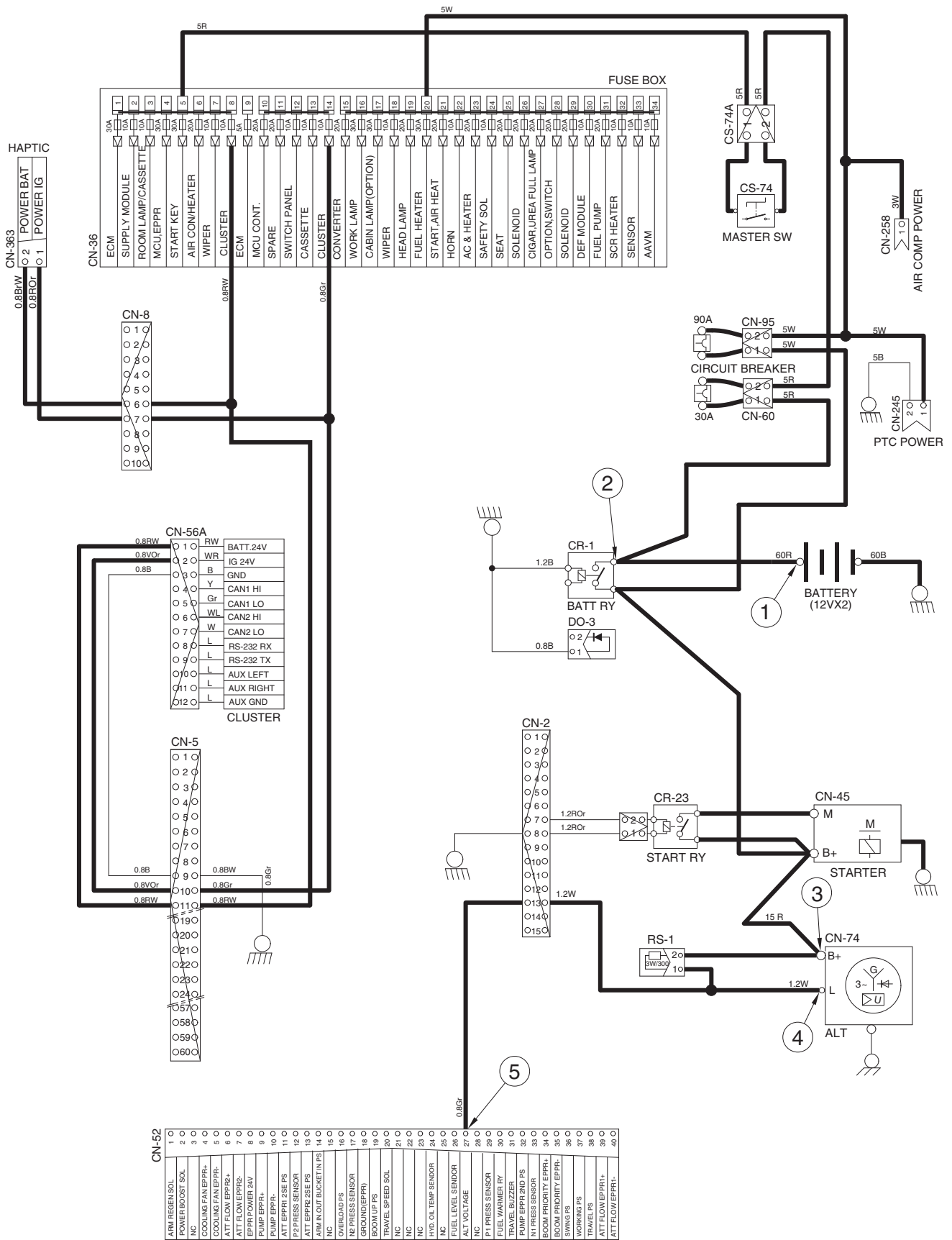

4. HEAD AND WORK LIGHT CIRCUIT

1) OPERATING FLOW

Fuse box (No.19) → Head light relay [CR-13 (30, 86)]

Fuse box (No.16) → Work light relay [CR-4 (30, 86)]

(1) Head light switch ON

Head light switch ON [CN-376 (13)] → Head light relay [CR-13 (85) → (87)]

→ Head light ON [CL-3 (2), CL-4 (1), CL-24 (2)]

→ I/conn [CN-7 (1)] → Cigar light [CL-2]

→ I/conn [CN-5 (60)] → Radio & USB player illumination ON [CN-27A (9)]
 → Hour meter [CN-48 (4)]

(2) Work light switch ON

Work light switch ON [CN-376 (4)] → Work light relay [CR-4 (85) → (87)]

→ I/conn [CN-12 (2)] → Work light ON [CL-5 (2), CL-6 (2), CL-36 (2), CL-37 (2)]

2) CHECK POINT

Engine	Start switch	Check point	Voltage
STOP	ON	① - GND (fuse box) ② - GND (head light switch power output) ③ - GND (head light relay) ④ - GND (head light) ⑤ - GND (fuse box) ⑥ - GND (work light switch power output) ⑦ - GND (work light relay) ⑧ - GND (work light)	20~25V

※ GND : Ground

HEAD AND WORK LIGHT CIRCUIT

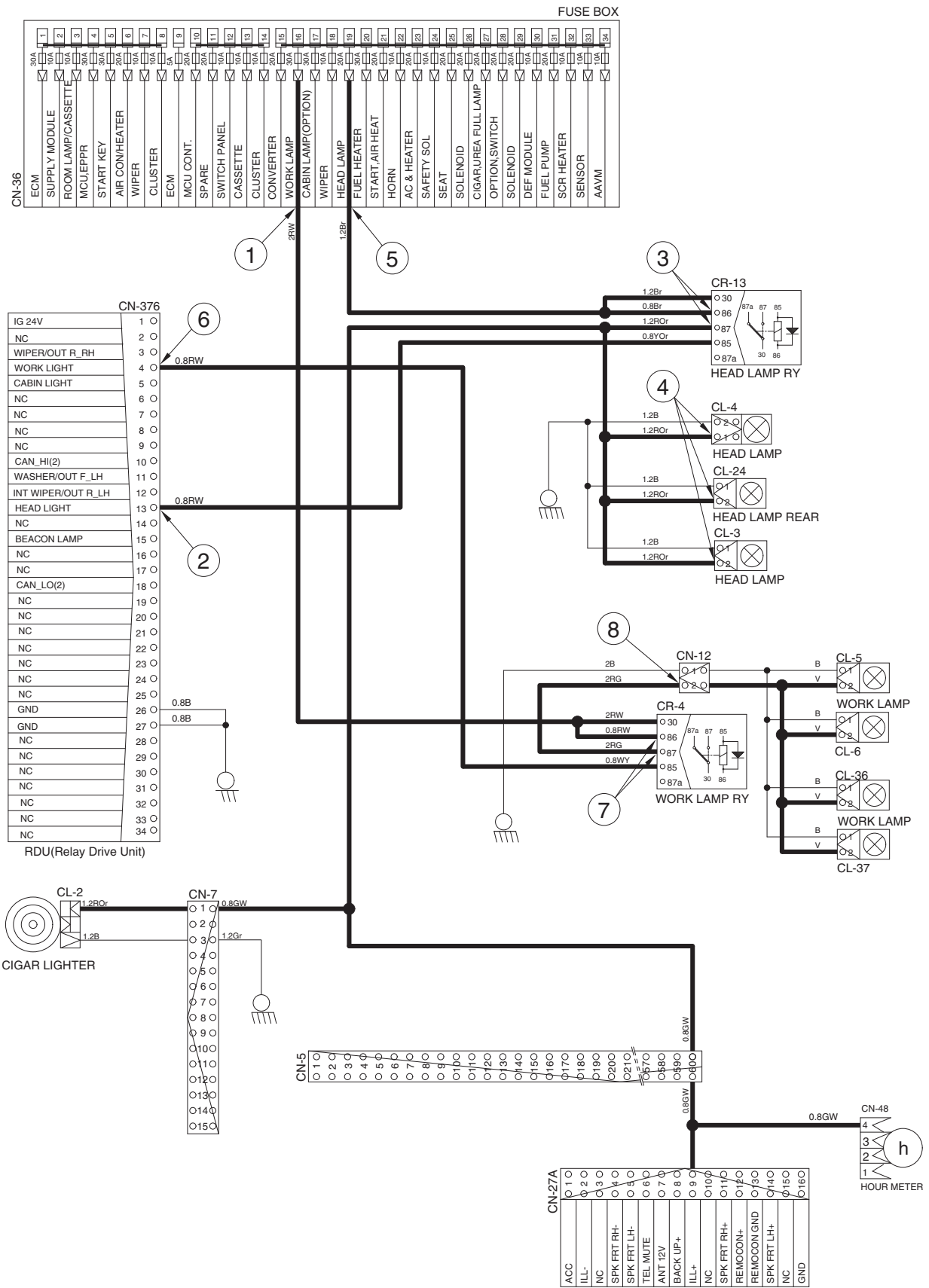

5. BEACON LAMP AND CAB LIGHT CIRCUIT

1) OPERATING FLOW

Fuse box (No.28) → Beacon lamp relay [CR-45 (2, 3)]

Fuse box (No.17) → Cab light relay [CR-9 (30, 86)]

(1) Beacon lamp switch ON

Beacon lamp switch ON [CN-376 (15)] → Beacon lamp relay [CR-45 (1)→ (5)]

→ I/conn [CN-5 (50)] → I/conn [CN-10 (10)] → Beacon lamp ON [CL-7]

(2) Cab light switch ON

Cab light switch ON [CN-376 (5)] → Cab lamp relay [CR-9 (85) → (87)]

→ I/conn [CN-5 (34, 38)] → I/conn [CN-10 (11)] → Cab light ON [CL-8 (2)]

→ I/conn [CN-10 (12)] → Cab light ON [CL-9 (2), CL-10 (2)]

2) CHECK POINT

Engine	Start switch	Check point	Voltage
STOP	ON	① - GND (fuse box) ② - GND (beacon lamp relay) ③ - GND (beacon lamp switch power output) ④ - GND (beacon lamp) ⑤ - GND (fuse box) ⑥ - GND (cab light relay) ⑦ - GND (cab lamp switch power output) ⑧ - GND (cab light)	20~25V

※ GND : Ground

BEACON LAMP AND CAB LIGHT CIRCUIT

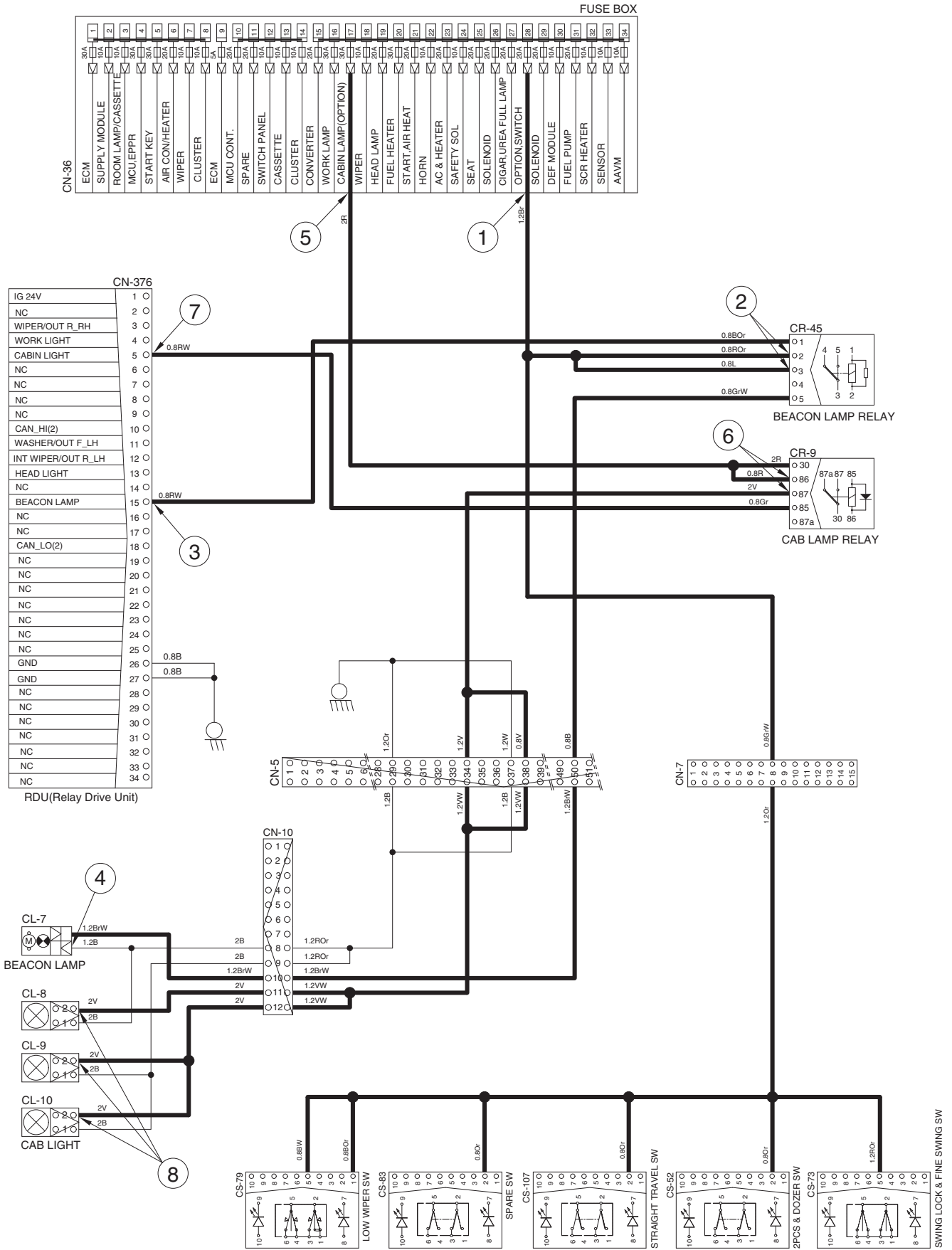

6. WIPER AND WASHER CIRCUIT

1) OPERATING FLOW

(1) Key switch ON

Fuse box (No.12) → Relay drive unit [CN-376 (1)]

Fuse box (No.7) → I/conn [CN-5 (18)] → I/conn [CN-17 (5)] → Wiper motor controller [CN-141(7)]
 → Wiper motor [CN-21(4)]

Fuse box (No.18) → I/conn [CN-5 (16)] → I/conn [CN-17 (4)] → Wiper motor controller [CN-141 (6)]
 → Low wiper motor [CN-407 (3)]
 → Washer pump [CN-22 (2)]

(2) Wiper switch ON (Intermittent)

Wiper switch ON [CN-376 (12)] → I/conn [CN-5 (20)] → I/conn [CN-17 (8)]

→ Wiper motor controller [CN-141 (10)→(3)] → Wiper motor [CN-21 (6)] → Intermittently operating

(3) Wiper switch ON (continual)

Wiper switch ON [CN-376 (3)] → I/conn[CN-5 (15)] → I/conn[CN-17 (2)]

→ Wiper motor controller [CN-141 (2) → (4)] → Wiper motor [CN-21 (2)] → Continual operating

(4) Washer switch ON

Washer switch ON [CN-376 (11)] → I/conn [CN-5 (17)] → I/conn [CN-17 (7)]

→ Wiper motor controller [CN-141 (9) → (8)] → I/conn [CN-17 (6)] → I/conn [CN-5 (19)]

→ Washer pump [CN-22 (1)] → Washer operating

Wiper switch ON [CN-376 (3)] → I/conn[CN-5 (15)] → I/conn[CN-17 (2)]

→ Wiper motor controller [CN-141 (2) → (4)] → Wiper motor [CN-21 (2)] → Continual operating

(5) Auto parking (when switch OFF)

Switch OFF [CN-376 (3, 12)] → Wiper motor parking position by wiper motor controller

2) OPERATING FLOW (LOW WIPER)

(1) Key switch ON

Fuse box (No. 28) → I/conn [CN-7 (8)] → Low wiper switch [CS-79 (1, 5)]

(2) Wiper switch ON (1st)

Wiper switch ON [CS-79 (2 → 3)] → I/conn [CN-7 (4)] → Wiper motor [CN-407 (1)] → Wiper operating

(3) Wiper switch ON (2nd)

Wiper switch ON [CS-79 (5 → 4)] → I/conn [CN-7 (6)] → Washer pump [CN-407 (2)] → Washer operating

Wiper switch ON [CS-79 (2 → 3)] → I/conn [CN-7 (4)] → Wiper motor [CN-407 (1)] → Wiper operating

3) CHECK POINT

Engine	Start switch	Check point	Voltage
STOP	ON	① - GND (fuse box)	20~25V
		② - GND (switch power input)	
		③ - GND (wiper power input)	
		④ - GND (switch power output)	
		⑤ - GND (switch power output)	0 ~ 5V
		⑥ - GND (wiper power input)	
		⑦ - GND (wiper power output)	24V
		⑧ - GND (low wiper motor)	

※ GND : Ground

WIPER AND WASHER CIRCUIT

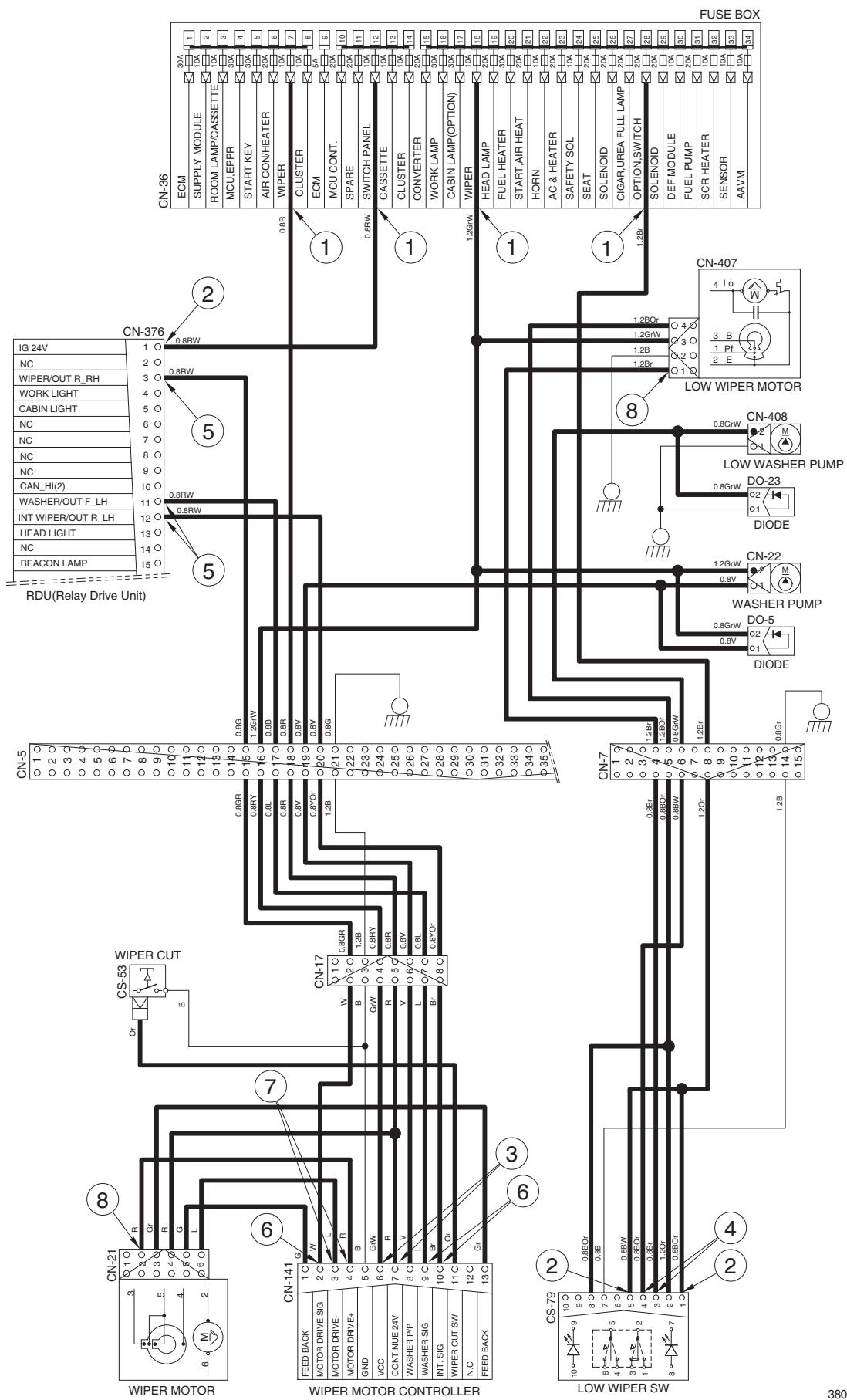

FUSE BOX

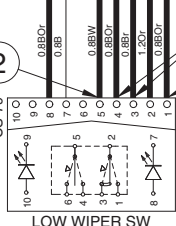
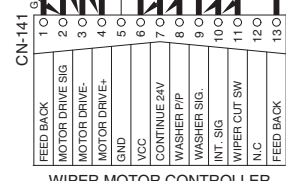
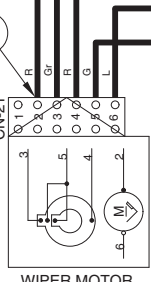
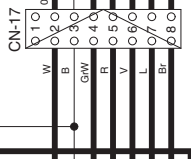
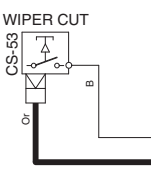
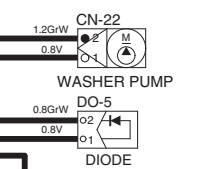
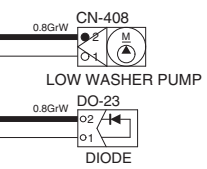
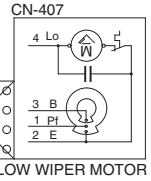
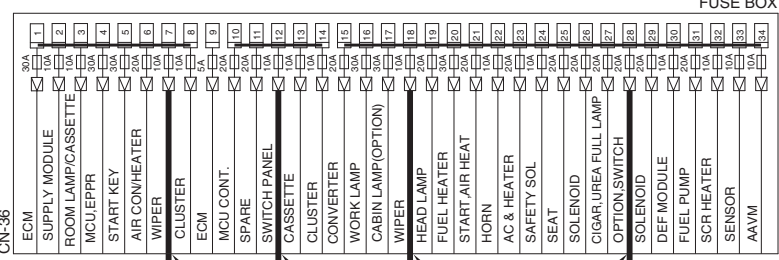
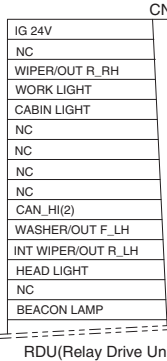

CONTROLLER CIRCUIT

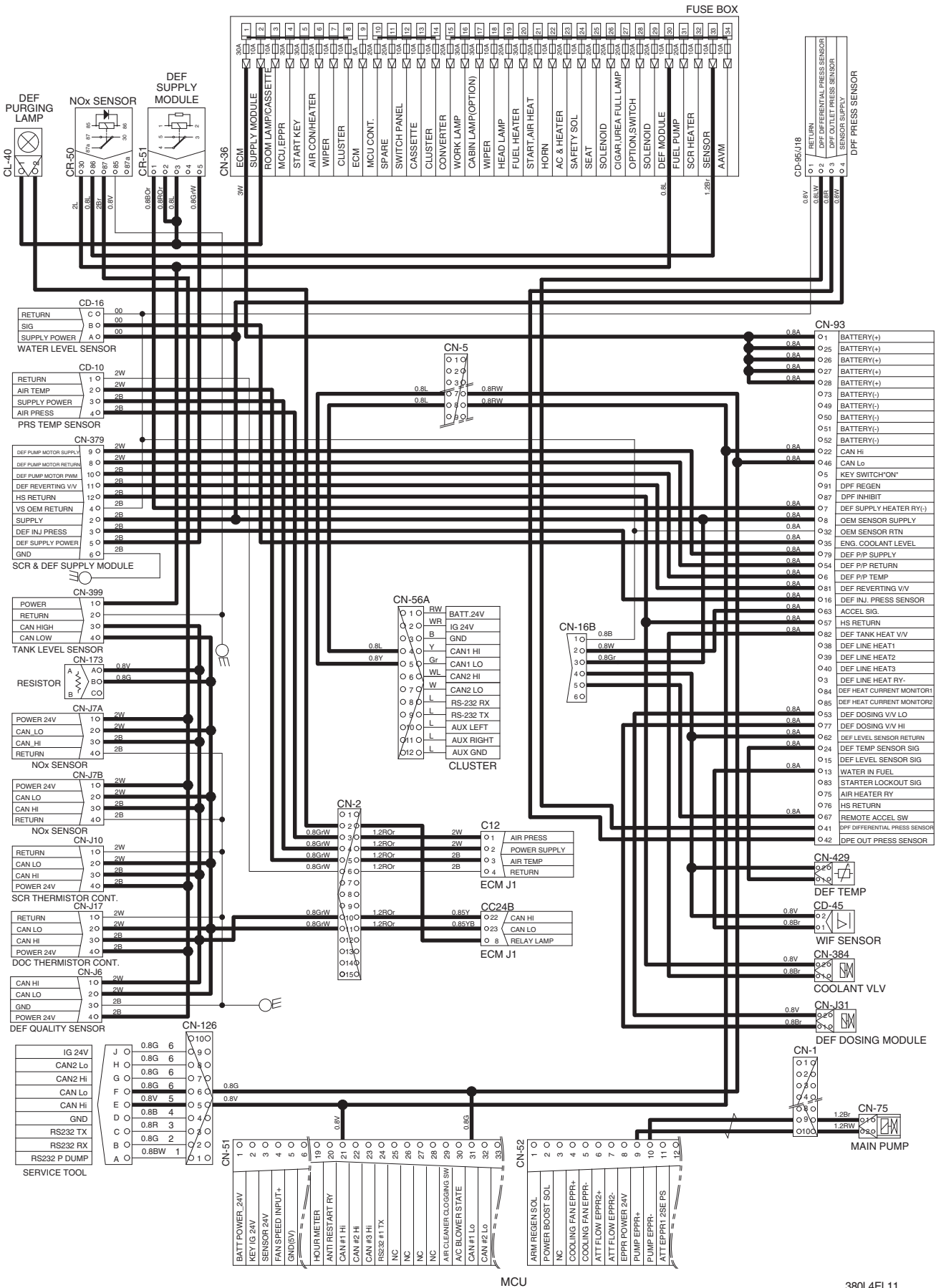

MONITORING CIRCUIT

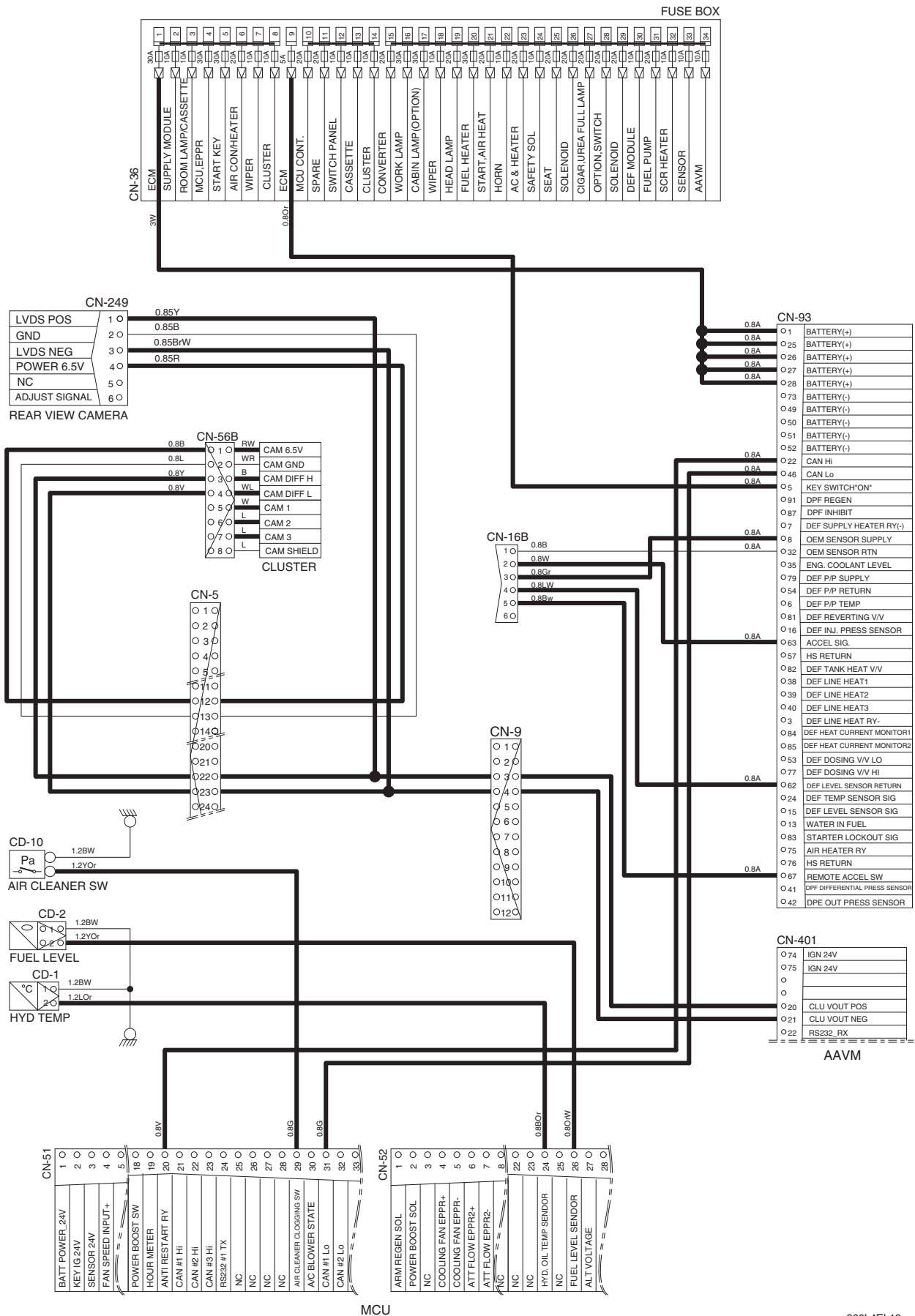

ELECTRIC CIRCUIT FOR HYDRAULIC (1/2)

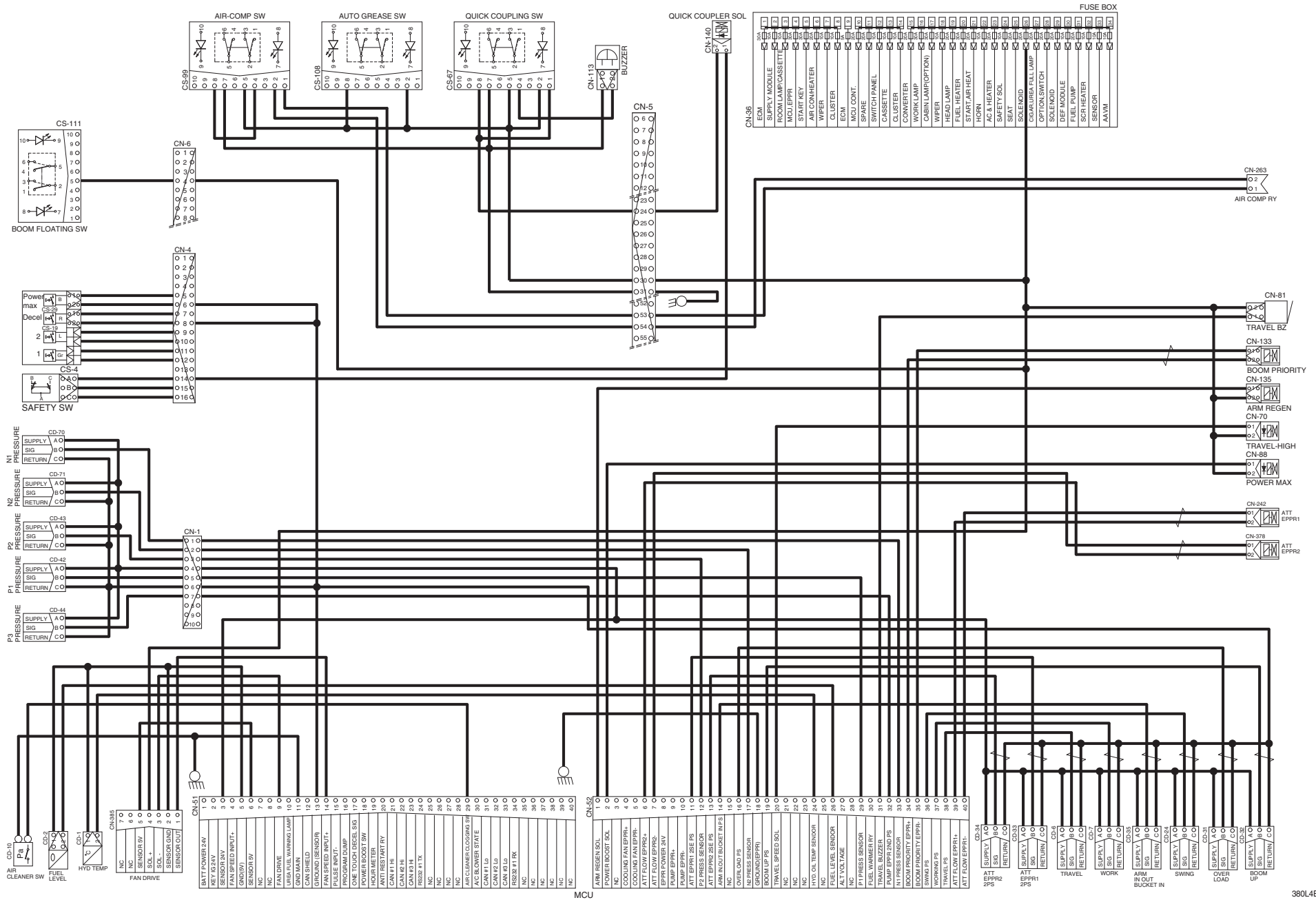

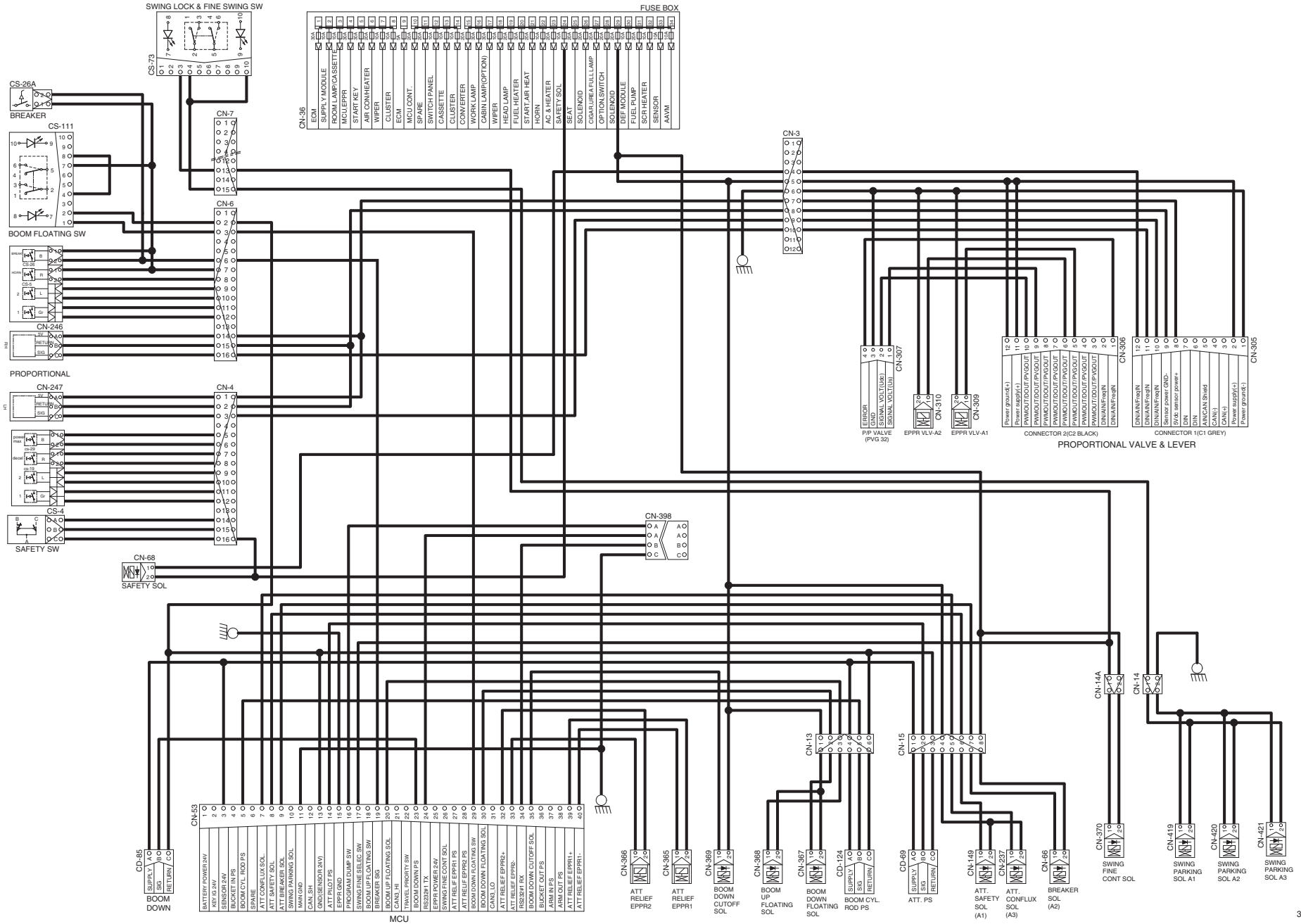

ELECTRIC CIRCUIT FOR HYDRAULIC (2/2)

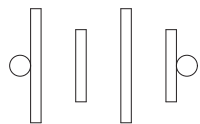
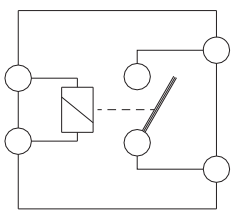
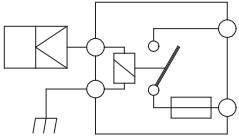
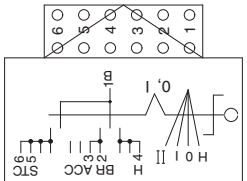
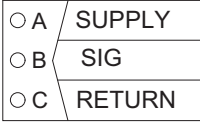
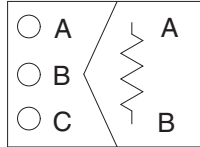

GROUP 3 ELECTRICAL COMPONENT SPECIFICATION

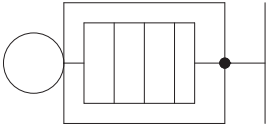
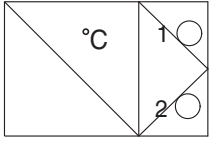
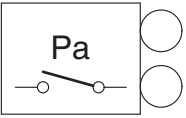
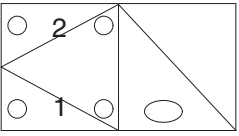
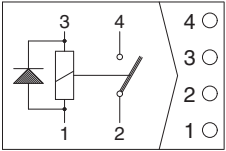
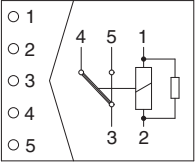
Part name	Symbol	Specifications	Check
Battery		12V × 160Ah (2EA)	※ Check specific gravity 1.280 over : Over charged 1.280 ~ 1.250 : Normal 1.250 below : Recharging
Battery relay	 <p style="text-align: center;">CR-1</p>	Rated load : 24V 100A (continuity) 1000A (30seconds)	※ Check coil resistance(M4 to M4) Normal : About 50 Ω ※ Check contact Normal : ∞ Ω
Glow plug relay	 <p style="text-align: center;">CR-24</p>	24V 200A	※ Check contact Normal : 0.942 Ω (For terminal 1-GND)
Start key	 <p style="text-align: center;">CS-2A</p>	B-BR : 24V 1A B-ACC : 24V 10A B-ST : 24V 40A	※ Check contact OFF : ∞ Ω (for each terminal) ON : 0 Ω (for terminal 1-3 and 1-2) START : 0 Ω (for terminal 1-6)
Pressure sensor	 <p style="text-align: center;"> ○ A SUPPLY ○ B SIG ○ C RETURN </p> <p> CD-6 CD-7 CD-24 CD-31 CD-32 CD-33 CD-34 CD-35 CD-42 CD-43 CD-44 CD-69 CD-70 CD-71 CD-85 CD-90 CD-124 </p>	8~30V	※ Check contact Normal : 0.1 Ω
Resistor	 <p style="text-align: center;"> ○ A ○ B ○ C </p> <p style="text-align: center;"> A A B B </p> <p style="text-align: center;">CN-173 CN-174</p>	4W	※ Check resistance A-B : 120 Ω

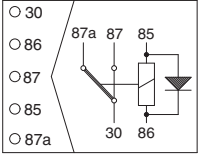
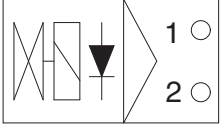
Part name	Symbol	Specifications	Check
Glow plug	 CN-80	24V 200A	※ Check resistance 0.25~0.12 Ω
Temperature sensor (hydraulic)	 CD-1	-	※ Check resistance 50°C : 804 Ω 80°C : 310 Ω 100°C : 180 Ω
Air cleaner pressure switch	 CD-10	N.O TYPE	※ Check contact High level : ∞ Ω Low level : 0 Ω
Fuel sender	 CD-2	-	※ Check resistance Full : 50 Ω 6/12 : 350 Ω 11/12 : 100 Ω 5/12 : 400 Ω 10/12 : 150 Ω 4/12 : 450 Ω 9/12 : 200 Ω 3/12 : 500 Ω 8/12 : 250 Ω 2/12 : 550 Ω 7/12 : 300 Ω 1/12 : 600 Ω Empty warning : 700 Ω
Relay (A/C blower)		24V 20A	※ Check resistance Normal : About 200 Ω (for terminal 1-3) 0 Ω (for terminal 2-4)
Relay	 CR-2 CR-5 CR-36 CR-39 CR-45 CR-51	24V 16A	※ Check resistance Normal : About 160 Ω (for terminal 1-2) 0 Ω (for terminal 3-4) ∞ Ω (for terminal 3-5)

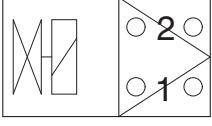
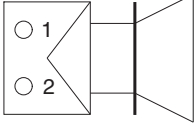
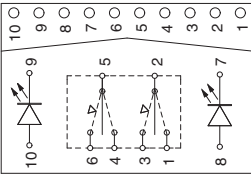
Part name	Symbol	Specifications	Check
Relay	 <p>CR-4 CR-7 CR-9 CR-13 CR-35 CR-46 CR-50 CR-52</p>	24V 16A	※ Check resistance Normal : About 160 Ω (for terminal 85-86) 0 Ω (for terminal 30-87a) ∞ Ω (for terminal 30-87)
Solenoid valve	 <p>CN-66 CN-68 CN-70 CN-88 CN-135 CN-140 CN-149 CN-237 CN-262A CN-262B CN-367 CN-368 CN-369 CN-370 CN-419 CN-420 CN-421</p>	24V 1A	※ Check resistance Normal : 15~25 Ω (for terminal 1-2)
EPPR valve	 <p>CN-75 CN-133 CN-154 CN-242 CN-309 CN-310 CN-365 CN-366 CN-378</p>	700mA	※ Check resistance Normal : 15~25 Ω (for terminal 1-2)
EPPR valve	 <p>CN-384 CN-J31</p>	700mA	※ Check resistance Normal : 15~25 Ω (for terminal 1-2)
Speaker	 <p>CN-23(LH) CN-24(RH)</p>	20W	※ Check resistance Normal : A few Ω
Switch (locking type)	 <p>CS-52 CS-67 CS-83 CS-99 CS-107 CS-108 CS-111</p>	24V 1.5A	※ Check contact Normal ON : 0 Ω (for terminal 3-7, 4-8) ∞ Ω (for terminal 7-9, 8-10) OFF : ∞ Ω (for terminal 3-7, 4-8) 0 Ω (for terminal 7-9, 8-10)

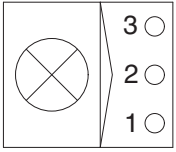
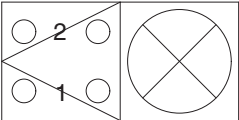
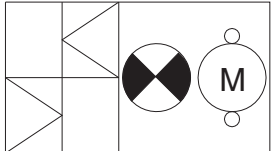
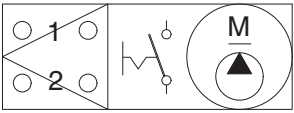
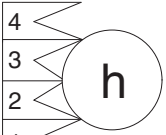
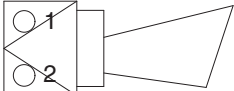
Part name	Symbol	Specifications	Check
Room lamp	 <p>CL-1</p>	24V 10W	※ Check disconnection Normal : 1.0 Ω ON : 0 Ω (For terminal 1-2) ∞ Ω (For terminal 1-3) OFF : ∞ Ω (For terminal 1-2) 0 Ω (For terminal 1-3)
Head lamp, Work lamp, Cab lamp	 <p>CL-3 CL-4 CL-5 CL-6 CL-8 CL-9 CL-10 CL-24 CL-36 CL-37</p>	24V 65W (H3 Type)	※ Check disconnection Normal : 1.2 Ω
Beacon lamp	 <p>CL</p>	21V 70W (H1 Type)	※ Check disconnection Normal : A few Ω
Fuel filler pump	 <p>CN-61</p>	24V 10A 35 l /min	※ Check resistance Normal : 1.0 Ω
Hour meter	 <p>CN-48</p>	16~32V	※ Check operation Supply power(24V) to terminal No.2 and connect terminal No.1 and ground
Horn	 <p>CN-20 CN-25</p>	DC22~28V 2A	※ Check operation Supply power(24V) to each terminal and connect ground.

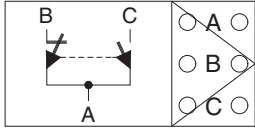
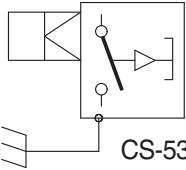
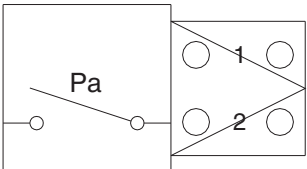
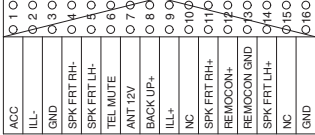
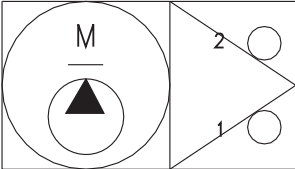
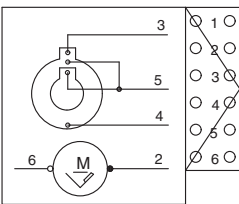
Part name	Symbol	Specifications	Check
Safety switch	 <p>CS-20</p>	24V 15A (N.C TYPE)	※ Check contact Normal : 1.0 Ω ON : 0 Ω (for terminal A-B) ∞ Ω (for terminal A-C) OFF : ∞ Ω (for terminal A-B) 0 Ω (for terminal A-C)
Wiper cut switch	 <p>CS-53</p>	24V (N.O TYPE)	※ Check contact Normal : 0 Ω (one pin to ground)
Receiver dryer	 <p>CN-29</p>	24V 2.5A	※ Check contact Normal : ∞ Ω
Radio & USB player	 <p>CN-27A</p>	24V 2A	※ Check voltage 20~25V (for terminal 1-3, 3-8)
Washer pump	 <p>CN-22 CN-408</p>	24V 3.8A	※ Check contact Normal : 10.7 Ω (for terminal 1-2)
Wiper motor	 <p>CN-21</p>	24V 2A	※ Check disconnection Normal : 7 Ω (for terminal 2-6)

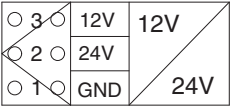
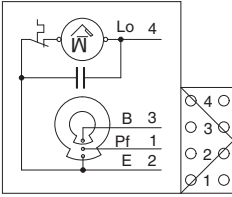
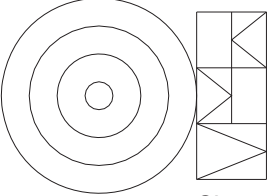
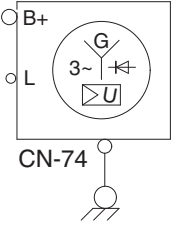
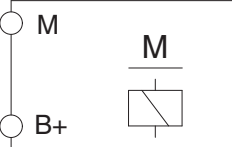
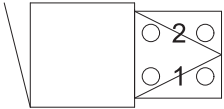
Part name	Symbol	Specifications	Check
DC/DC Converter	 <p>CN-138</p>	12V 3A	※ Check voltage 24V (for terminal 1-2) 12V (for terminal 1-3)
Low wiper motor	 <p>CN-407</p>	24V	-
Cigar lighter	 <p>CL-2</p>	24V 5A 1.4W	※ Check coil resistance Normal : About 1M Ω ※ Check contact Normal : ∞ Ω Operating time : 5~15sec
Alternator	 <p>CN-74</p>	Denso 24V 95A	※ Check contact Normal : 0 Ω (for terminal B ⁺ -L) Normal : 24~27.5V
Starter	 <p>CN-45</p>	Denso 24V 7.8kW	※ Check contact Normal : 0.1 Ω
Travel alarm	 <p>CN-81</p>	24V 0.5A	※ Check contact Normal : 5.2 Ω

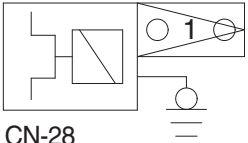
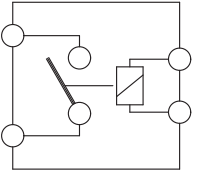
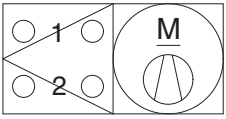
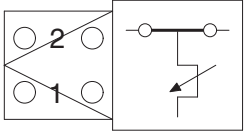
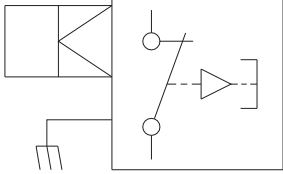
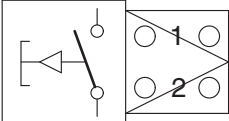
Part name	Symbol	Specifications	Check
Air conditioner compressor	 CN-28	24V 79W	※ Check contact Normal : 13.4 Ω
Start relay	 CR-23	24V 300A	※ Check contact Normal : 0.94 Ω (for terminal 1-2)
Blower motor		24V 9.5A	※ Check resistance Normal : 2.5 Ω (for terminal 1-2)
Duct sensor (switch)		1°C OFF 4°C ON	※ Check resistance Normal : 0 Ω (for terminal 1-2), the atmosphere temp : Over 4°C
Door switch	 CS-1	24V 2W	※ Check resistance Normal : About 5M Ω
Switch (power max, one touch decel, horn, breaker)	 CS-5 CS-19 CS-26 CS-29	24V 6A	※ Check resistance Normal : ∞ Ω

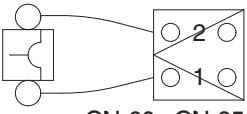
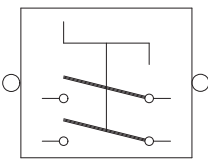
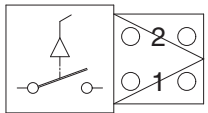
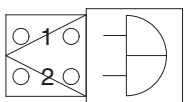
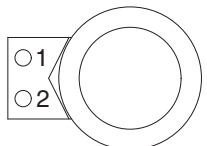
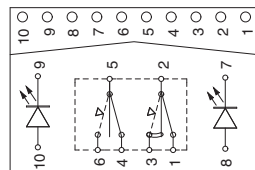
Part name	Symbol	Specifications	Check
Circuit breaker	 <p>CN-60 CN-95</p>	CN-60 : 30A CN-95 : 90A	※ Check disconnection Normal : 0 Ω (connect ring terminal and check resist between terminal 1 and 2)
Master switch	 <p>CS-74A, CS-74B</p>	6-36V	※ Check disconnection Normal : 0.1 Ω
Breaker switch	 <p>CS-26A</p>	24V	※ Check resistance Normal : ∞ Ω
Quick clamp buzzer	 <p>CN-113</p>	24V 200mA 107 ± 4dB	-
Socket	 <p>CN-139</p>	12V 10A	-
Switch	 <p>CS-79</p>	24V 8A	※ Check contact Normal ON : 0 Ω (for terminal 1-2, 4-5) ∞ Ω (for terminal 2-3, 5-6) OFF : ∞ Ω (for terminal 1-2, 4-5) 0 Ω (for terminal 2-3, 5-6)

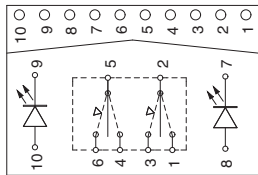
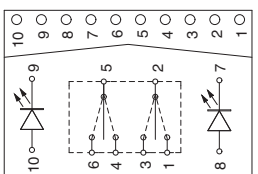
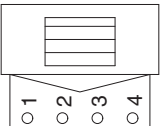
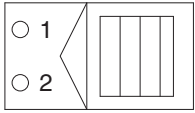
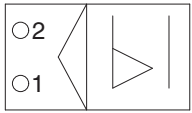
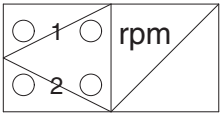
Part name	Symbol	Specifications	Check
Switch	 <p>CS-100</p>	24V 8A	※ Check contact Normal OFF : $\infty \Omega$ (for terminal 1-2, 1-3, 4-5, 5-6)
Switch	 <p>CS-73</p>	24V 8A	※ Check contact Normal OFF : $\infty \Omega$ (for terminal 1-2, 1-3, 4-5, 5-6)
Fuel heater	 <p>CN-96</p>	-	-
DEF/AdBlue® line heater	 <p>CN-381 CN-382 CN-383</p>	-	-
WIF sensor	 <p>CD-45</p>	-	-
Fan speed sensor	 <p>CD-52</p>	-	-

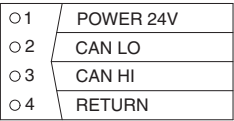
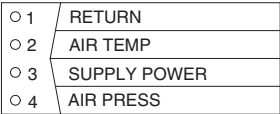
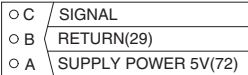
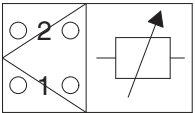
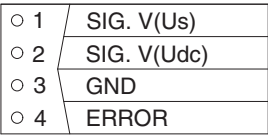
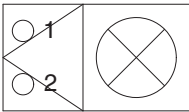
Part name	Symbol	Specifications	Check
DEF/AdBlue® sensor	 <p>CN-399 CN-J6 CN-J7A CN-J7B CN-J10 CN-J17</p>	-	
PRS temp sensor	 <p>CD-10</p>	-	-
Water level sensor	 <p>CD-16</p>	-	-
Temperature sensor (A/C incar, A/C ambient, DEF/AdBlue®)	 <p>CN-429</p>	-	
Proportional valve sensor	 <p>CN-307</p>	-	-
DEF/AdBlue® fill up warning lamp	 <p>CL-40</p>	-	

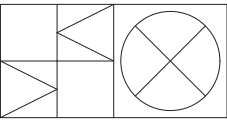
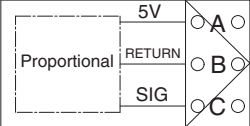
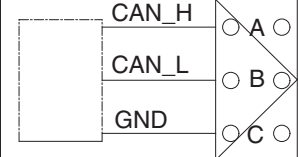
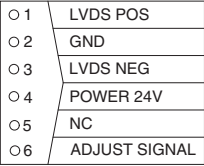
Part name	Symbol	Specifications	Check
DEF/AdBlue® fill up warning lamp (LED)	 <p>CL-41</p>	-	-
Proportional valve sensor	 <p>CN-246 CN-247</p>	-	-
Start button	 <p>CS-2B</p>	-	-
Camera	 <p>CN-249 CN-402 CN-403 CN-404 CN-405</p>	-	-

GROUP 4 CONNECTORS

1. CONNECTOR DESTINATION

Connector number	Type	No. of pin	Destination	Connector part No.	
				Female	Male
CN-1	AMP	10	l/conn (Frame harness-Pump PS harness)	S816-010002	S816-110002
CN-2	-	15	l/conn (Frame harness-Engine harness)	121583-0135	368301-1
CN-3	TYCO	12	l/conn (Frame harness-Pro vlv harness)	174661-2	368537-1
CN-4	AMP	16	l/conn (Console harness LH-Frame harness)	368047-1	368050-1
CN-5	DEUTSCH	60	l/conn (Side harness RH-Frame harness)	DRB16-60SAE-L018	DRB12-60P-L018
CN-6	AMP	16	l/conn (Console harness RH-Frame harness)	368050-1	368047-1
CN-7	AMP	15	l/conn (Console harness RH-Frame harness)	2-85262-1	368301-1
CN-8	AMP	10	l/conn (Console harness RH-Frame harness)	S816-010002	174655-2
CN-9	DEUTSCH	12	l/conn (AAVM harness-Frame harness)	DT06-12SA-P021	DT04-12PA-P021
CN-10	DEUTSCH	12	l/conn (Side harness RH-Cab harness)	DT06-12S-EP06	DT04-12PA-P021
CN-11	DEUTSCH	8	l/conn (Frame harness-Aircon harness)	DT06-8S-EP06	-
CN-12	DEUTSCH	2	l/conn (Frame harness-Boom wire harness)	DT06-2S-EP06	DT04-2P-E004
CN-13	AMP	8	Boom floating	174262-2	174264-2
CN-15	AMP	8	l/conn (Frame harness-2 way harness)	174982-2	174984-2
CN-16	AMP	6	Emergency engine start & speed control	S816-006002	S816-106002
CN-17	AMP	8	l/conn (Side harness RH-Wiper harness)	S816-008002	S816-108002
CN-18	AMP	2	Washer tank 2	174352-2	174354-2
CN-20	MOLEX	2	Horn	36825-0211	-
CN-21	AMP	6	Wiper motor	S810-006202	-
CN-22	KET	2	Washer tank 1	MG640605	-
CN-23	KET	2	Speaker-LH	MG610070	-
CN-24	KET	2	Speaker-RH	MG610070	-
CN-25	MOLEX	2	Horn	36825-0211	-
CN-27A	KUM	16	Radio & USB player	PK145-16017	-
CN-27B	AMP	8	Radio & USB player	-	174984-2
CN-28	KUM	1	Aircon compressor	NMWP01F-B	-
CN-29	KET	2	Receiver dryer	MG640795	-
CN-36	-	-	Fuse & relay box	21Q7-10910	-
CN-45	RING-TERM	-	Starter motor B+	S820-108000	-
CN-48	KET	1	Hour meter	2-520193-2	-
CN-51	DEUTSCH	40	MCU	DRC26-40SA	-
CN-52	DEUTSCH	40	MCU	DRC26-40SB	-
CN-53	DEUTSCH	40	MCU	DRC26-40SC	-
CN-56A	AMP	12	Cluster	-	174663-2
CN-56B	AMP	8	Cluster	-	174984-2
CN-60	YAZAKI	2	Circuit breaker	-	7222-4220-30
CN-61	DEUTSCH	2	Fuel filler pump	DT06-2S-EP06	-

Connector number	Type	No. of pin	Destination	Connector part No.	
				Female	Male
CN-66	DEUTSCH	2	Breaker solenoid	DT06-2S-EP06	-
CN-68	DEUTSCH	2	Safety solenoid	DT06-2S-EP06	-
CN-70	DEUTSCH	2	Travel high solenoid	DT06-2S-EP06	-
CN-74	RING-TERM	1	Alternator "L" terminal	S820-105000	-
CN-74	RING-TERM	1	Alternator "B" terminal	S820-108000	-
CN-75	AMP	2	Pump EPPR valve	S816-002002	-
CN-80	RING-TERM	-	Glow plug	S820-306000	-
CN-81	DEUTSCH	2	Travel buzzer solenoid	DT06-2S-EP06	-
CN-88	DEUTSCH	2	Power max solenoid	DT06-2S-EP06	-
CN-93	DELPHI	60	ECM	13964577	-
CN-95	YAZAKI	2	Circuit breaker	-	7222-4220-30
CN-100	KET	1	ECM ground	MG640944-5	-
CN-113	KET	2	Buzzer	MG651205-5	-
CN-125	Econoseal J	4	GPS connector	S816-004002	S816-104002
CN-125A	DEUTSCH	12	GPS	DT06-12S-P021	DT04-12PA-P021
CN-126	AMP	10	I/conn (Frame harness-Service tool)	2-1418390-1	S816-110002
CN-126	DEUTSCH	4	RS232	DT06-4S	DT06-4P
CN-133	DEUTSCH	2	Boom priority solenoid	DT06-2S-EP06	-
CN-135	DEUTSCH	2	Arm regeneration solenoid	DT06-2S-EP06	-
CN-138	FASTEN	3	DC/DC Converter	S810-003202	-
CN-139	FASTEN	2	12V socket	172434-2	-
CN-140	DEUTSCH	2	Quick clamp solenoid	DT06-2S-EP06	DT04-2P-E005
CN-141	AMP	13	Wiper motor controller	172498-1	-
CN-147	AMP	4	Fuel heater	2-967325-3	-
CN-149	DEUTSCH	2	Attach safety solenoid	DT06-2S-EP06	-
CN-154	DEUTSCH	2	Cooling fan	DT06-2S-EP06	-
CN-156	DEUTSCH	2	Air seat heat	DT06-2S-EP06	DT04-2P
CN-157	AMP	1	Antena power	S822-014002	-
CN-173	DEUTSCH	3	Resistor	DT06-3S-EP06	-
CN-174	DEUTSCH	3	Resistor	DT06-3S-EP06	DT04-3P-EP10
CN-237	DEUTSCH	2	Attach conflux solenoid	DT06-2S-EP06	-
CN-242	DEUTSCH	2	Attach EPPR 1	DT06-2S-EP06	-
CN-245	FCI	4	PTC power	180900-0	-
CN-246	DEUTSCH	3	Proportional valve-RH	DT06-3S	DT04-3P
CN-247	DEUTSCH	3	Proportional valve-LH	DT06-3S	DT04-3P
CN-249	DEUTSCH	4	Rear view camera	DT06-4S-E005	DT04-4P-E005
CN-258	KET	1	Air compressor power	MG640944-5	MG650943-5
CN-262	DEUTSCH	2	Straight travel solenoid	DT06-2S-EP06	DT04-2P-E005
CN-262A	DEUTSCH	2	Straight travel solenoid 1	DT06-2S-EP06	-

Connector number	Type	No. of pin	Destination	Connector part No.	
				Female	Male
CN-262B	DEUTSCH	2	Straight travel solenoid 2	DT06-2S-EP06	-
CN-263	DEUTSCH	2	Air compressor relay	DT06-2S-EP06	DT04-2P-E005
CN-305	DEUTSCH	12	Proportional-Connector-1	DTM06-12SA	-
CN-306	DEUTSCH	12	Proportional-Connector-2	DTM06-12SB	-
CN-307	DEUTSCH	3	Proportional-Service tool	DT06-3S-EP06	DT04-3P-E005
CN-308	AMP	4	Proportional-PVG32	2-967059-1	-
CN-309	DEUTSCH	2	Proportional-EPPR valve A1	DT06-2S-EP06	-
CN-310	DEUTSCH	2	Proportional-EPPR valve A2	DT06-2S-EP06	-
CN-363	AMP	12	Haptic controller	174045-2	-
CN-365	DEUTSCH	2	Attach relief EPPR valve 1	DT06-2S-EP06	DT04-2P-E005
CN-366	DEUTSCH	2	Attach relief EPPR valve 2	DT06-2S-EP06	DT04-2P-E005
CN-367	AMP	2	Boom down floating solenoid	85202-1	-
CN-368	DEUTSCH	2	Boom up floating solenoid	DT06-2S-EP06	-
CN-369	DEUTSCH	2	Boom down cut off solenoid	DT06-2S-EP06	-
CN-376	TYCO	34	Relay drive unit	4-1437290-1	-
CN-378	DEUTSCH	2	Attach EPPR 2	DT06-2S-EP06	-
CN-379	TYCO	12	SCR supply module	1-1703639-1	-
CN-381	DELPHI	2	DEF/AdBlue® line heater 1	12162194	-
CN-382	DELPHI	2	DEF/AdBlue® line heater 2	12162194	-
CN-383	DELPHI	2	DEF/AdBlue® line heater 3	12162194	-
CN-384	AMP	2	Coolant valve	174352-2	-
CN-385	-	7	Fan clutch	965570	-
CN-398	DEUTSCH	4	RS232	DT06-4S-E005	DT04-4P-E005
CN-399	TYCO	4	DEF/AdBlue® tank level sensor	1-967325-1	-
CN-402	DEUTSCH	6	Front view camera	DT06-6S-P021	DT04-6P-P021
CN-403	DEUTSCH	6	Rear view camera	DT06-6S-EP06	DT04-6P-EP14
CN-404	DEUTSCH	6	LH view camera	DT06-6S-EP06	DT04-6P-EP14
CN-405	DEUTSCH	6	RH view camera	DT06-6S-EP06	DT04-6P-EP14
CN-406	DEUTSCH	3	RS-232 (AAVM)	DT06-3S-EP06	DT04-3P-E005
CN-407	FCI	4	Low wiper motor	180900-0	-
CN-408	KET	2	Washer tank 2	MG640605	-
CN-419	DEUTSCH	2	Swing parking-A1	DT06-2S-EP06	-
CN-420	DEUTSCH	2	Swing parking-A2	DT06-2S-EP06	-
CN-421	DEUTSCH	2	Swing parking-A3	DT06-2S-EP06	-
CN-427	MOLEX	4	Reader-RMS	039012040	026013096
		12		5557-12R	5559-12P
CN-429	DELPHI	4	CAC Out temp	12162197	-
CN-J6	DEUTSCH	12	DEF/AdBlue® quality sensor	-	DT04-12PA-P021
CN-J7A	TYCO	4	DOC NOx sensor	4-1418390-1	-
CN-J7B	TYCO	4	SCR NOx sensor	1-1418390-1	-

Connector number	Type	No. of pin	Destination	Connector part No.	
				Female	Male
CN-J10	TYCO	4	SCR Thermistor	3-1418390-1	-
CN-J17	TYCO	4	DOC Thermistor	2-1418390-1	-
CN-J31	BOSCH	2	DEF/AdBlue® dosing module	1_928_403_874	-
· Relay					
CR-1	RING-TERM	-	Battery relay	ST710289-2	-
CR-2	-	5	Horn relay	-	-
CR-4	-	5	Working lamp relay	-	-
CR-5	-	5	Anti restart relay	-	-
CR-7	-	5	Aircon compressor relay	-	-
CR-9	-	5	Cabin lamp relay	-	-
CR-12	FCI	4	Air cleaner relay	-	54200419
CR-13	-	5	Head lamp relay	-	-
CR-23	KET	2	Start relay	-	S814-102001
CR-24	RING TERM	1	Preheat relay	S822-014000	-
CR-35	-	5	Power relay	-	-
CR-36	-	5	Air preheat relay	-	-
CR-39	-	5	Starter lock out relay	-	-
CR-45	-	5	Beacon lamp relay	-	-
CR-46	-	5	Fuel warmer relay	-	-
CR-50	-	5	NOx sensor relay	-	-
CR-51	-	5	DEF/AdBlue® module relay	-	-
CR-52	-	5	Line heater relay	-	-
· Switch					
CS-1	SHUR	1	Door switch	S822-014002	-
CS-2A	WP	6	Start key switch	S814-006100	-
CS-2B	DEUTSCH	3	Reader	DT06-3S-EP06	DT04-3P-E005
CS-4	DEUTSCH	3	Safety switch	DT06-3S	-
CS-5	DEUTSCH	2	Horn switch	-	DT04-2P
CS-19	DEUTSCH	2	One touch decel switch	-	DT04-2P
CS-26	DEUTSCH	2	Breaker switch	DT06-2S	-
CS-26A	AMP	2	Breaker pedal switch	S816-002002	S816-102002
CS-29	DEUTSCH	2	Power max switch	DT06-2S	-
CS-33	AMP	6	Emergency engine stop switch	S816-006002	S816-106002
CS-52	CARLING	10	Dozer & 2PCS boom switch	VC2-01	-
CS-53	AMP	1	Wiper cut switch	S822-014002	-
CS-67	CARLING	10	Quick clamp switch	VC2-01	-
CS-73	CARLING	10	Swing lock & fine switch	VC2-01	-
CS-74A	-	2	Master switch	4-1437290-1	S813-130201
CS-74B	DEUTSCH	2	Master switch	DT06-2S-EP06	DT04-2P-E005
CS-78	CARLING	10	Lower wiper switch	VC2-01	-

Connector number	Type	No. of pin	Destination	Connector part No.	
				Female	Male
CS-83	CARLING	10	Spare switch	VC2-01	-
CS-99	CARLING	10	Air compressor switch	VC2-01	-
CS-100	CARLING	10	SCR system cleaning switch	VC2-01	-
CS-107	CARLING	10	Travel straight switch	VC2-01	-
CS-108	CARLING	10	Auto grease switch	VC2-01	-
CS-111	CARLING	10	Boom floating switch	VC2-01	-
· Light					
CL-1	KET	3	Room lamp	MG651032	-
CL-2	AMP	1	Cigar lighter	S822-014002	S822-114002
CL-3	DEUTSCH	2	Head lamp-LH	DT06-2S-EP06	-
CL-4	DEUTSCH	2	Head lamp-RH	DT06-2S-EP06	-
CL-5	DEUTSCH	2	Work lamp-LH	DT06-2S-EP06	-
CL-6	DEUTSCH	2	Work lamp-RH	DT06-2S-EP06	-
CL-7	SHUR	1	Beacon lamp	S822-014002	S822-114002
CL-8	DEUTSCH	2	Cab light-LH	DT06-2S-EP06	DT04-2P
CL-9	DEUTSCH	2	Cab light-RH	DT06-2S-EP06	DT04-2P
CL-10	DEUTSCH	2	Cab light	DT06-2S-EP06	DT04-2P
CL-24	DEUTSCH	2	Work lamp - rear	DT06-2S-EP06	DT04-2P-E005
CL-36	DEUTSCH	2	Work lamp - LH	DT06-2S-EP06	-
CL-37	DEUTSCH	2	Work lamp - RH	DT06-2S-EP06	-
CL-40	DEUTSCH	2	DEF/AdBlue® lamp	DT06-2S-EP06	-
CL-41	AMP	2	DEF/AdBlue® fill up warning lamp	S822-01400	-
· Sensor, sender					
CD-1	AMP	2	Hydraulic oil temp sender	85202-1	-
CD-2	DEUTSCH	2	Fuel sender	DT06-2S-EP06	-
CD-6	DEUTSCH	3	Travel pressure switch	DT06-3S-EP06	-
CD-7	DEUTSCH	3	Working pressure switch	DT06-3S-EP06	-
CD-10	SUMITOMO	4	Air cleaner switch	6098-0144	-
CD-10	AMP	4	Air cleaner sensor	85202-1	-
CD-16	AMP	3	Water level sensor	12110293	-
CD-24	DEUTSCH	3	Swing sensor	DT06-3S-EP06	-
CD-31	DEUTSCH	3	Overload sensor	DT06-3S-EP06	DT04-3P-E005
CD-32	DEUTSCH	3	Boom up sensor	DT06-3S-EP06	-
CD-35	DEUTSCH	3	Arm in/out and bucket in sensor	DT06-3S-EP06	-
CD-36	DEUTSCH	3	Arm out sensor	DT06-3S-EP06	-
CD-42	DEUTSCH	3	Pump pressure 1	DT06-3S-EP06	-
CD-43	DEUTSCH	3	Pump pressure 2	DT06-3S-EP06	-
CD-44	DEUTSCH	3	Pump pressure 3	DT06-3S-EP06	-
CD-45	DEUTSCH	2	WIF sensor	DT06-2S-EP06	-

Connector number	Type	No. of pin	Destination	Connector part No.	
				Female	Male
CD-52	AMP	1	Fan rpm sensor	ST730135-2	-
CD-69	DEUTSCH	3	Attach pressure sensor	DT06-3S-EP06	-
CD-70	DEUTSCH	3	N1 pressure sensor	DT06-3S-EP06	-
CD-71	DEUTSCH	3	N2 pressure sensor	DT06-3S-EP06	-
CD-85	DEUTSCH	3	Boom down sensor	DT06-3S-EP06	-
CD-87	DEUTSCH	3	Bucket out sensor	DT06-3S-EP06	-
CD-90	DEUTSCH	3	Arm in sensor	DT06-3S-EP06	-
CD-91	DEUTSCH	3	Bucket in sensor	DT06-3S-EP06	-
CD-124	DEUTSCH	3	Boom cylinder rod pressure snensor	DT06-3S-EP06	-

2. CONNECTION TABLE FOR CONNECTORS

1) PA TYPE CONNECTOR

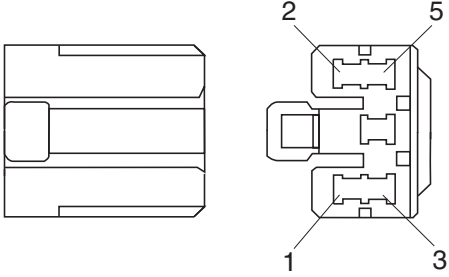
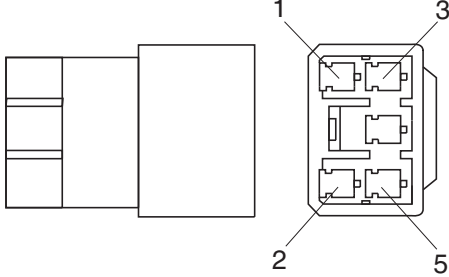
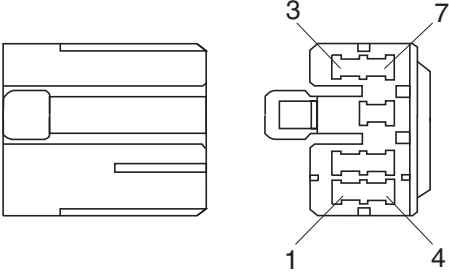
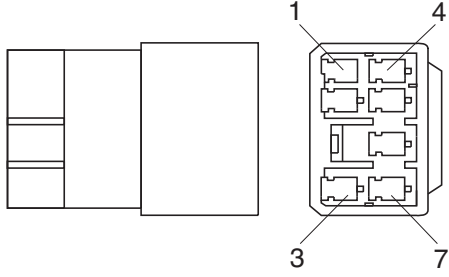
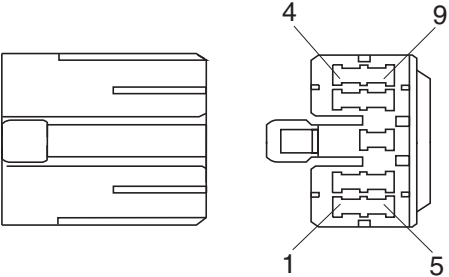
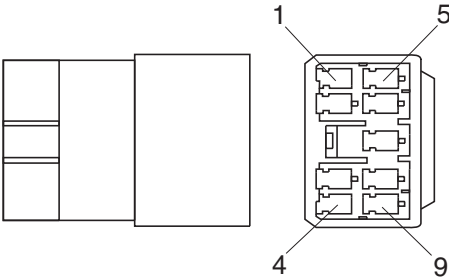
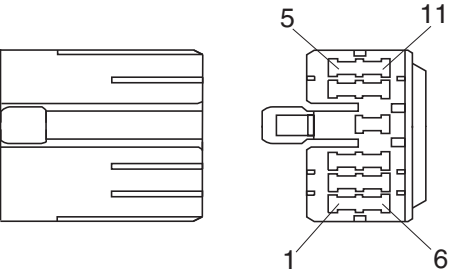
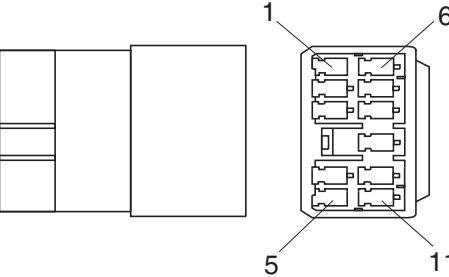
No. of pin	Receptacle connector (female)	Plug connector (male)
5	 <p style="text-align: center;">S811-005002</p>	 <p style="text-align: center;">S811-105002</p>
7	 <p style="text-align: center;">S811-007002</p>	 <p style="text-align: center;">S811-107002</p>
9	 <p style="text-align: center;">S811-009002</p>	 <p style="text-align: center;">3S811-109002</p>
11	 <p style="text-align: center;">S811-011002</p>	 <p style="text-align: center;">S811-111002</p>

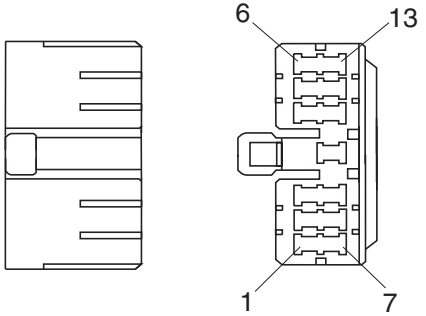
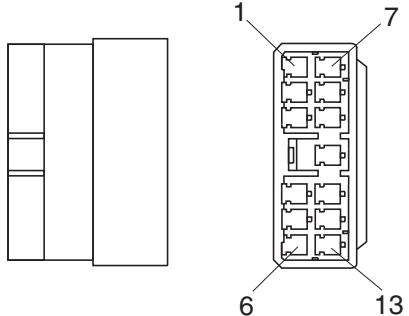
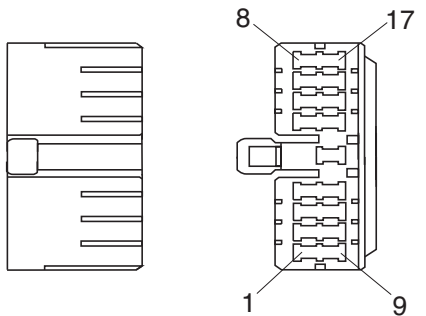
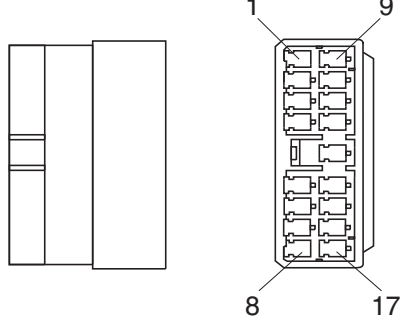
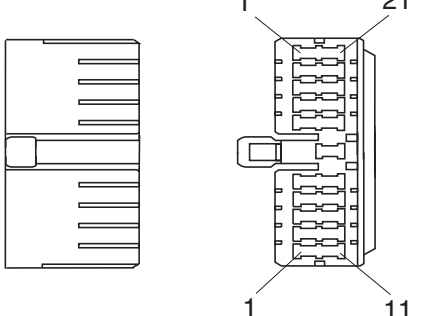
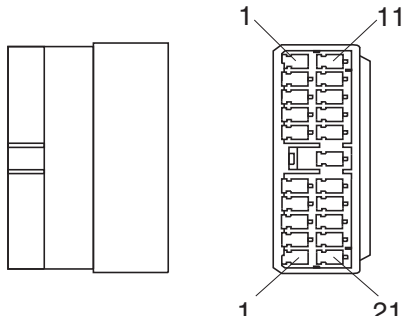
No. of pin	Receptacle connector (female)	Plug connector (male)
13	 <p style="text-align: center;">S811-013002</p>	 <p style="text-align: center;">S811-113002</p>
17	 <p style="text-align: center;">S811-017002</p>	 <p style="text-align: center;">S811-117002</p>
21	 <p style="text-align: center;">S811-021002</p>	 <p style="text-align: center;">S811-121002</p>

2) J TYPE CONNECTOR

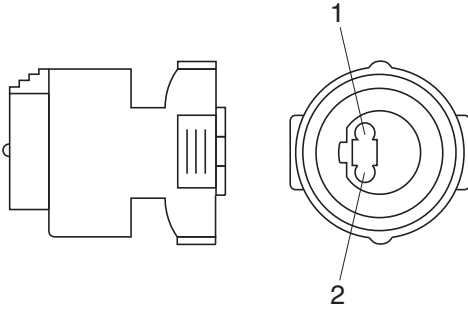
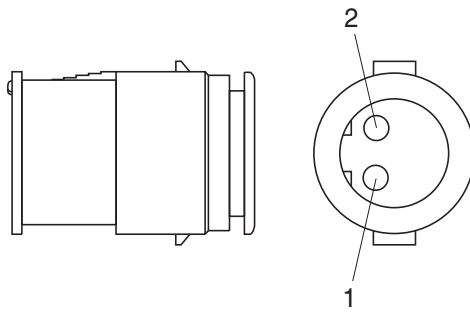
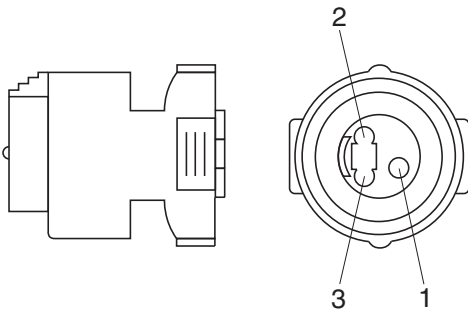
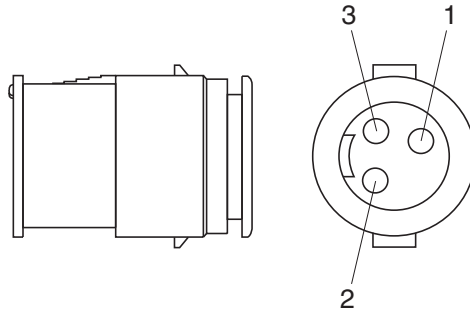
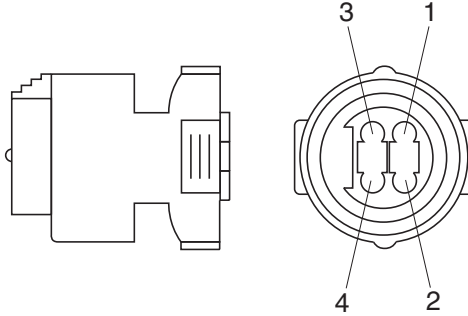
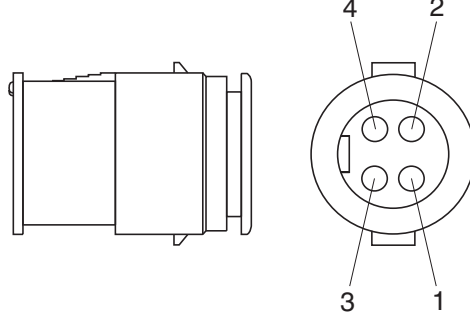
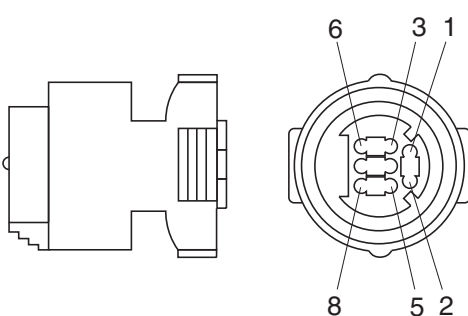
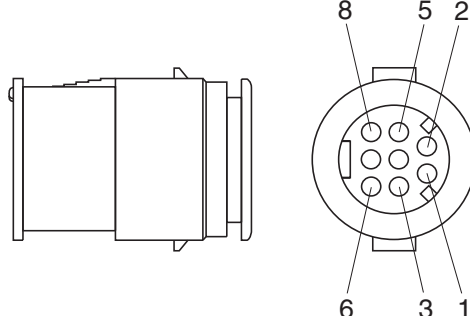
No. of pin	Receptacle connector (female)	Plug connector (male)
2	 <p style="text-align: center;">S816-002001</p>	 <p style="text-align: center;">S816-102001</p>
3	 <p style="text-align: center;">S816-003001</p>	 <p style="text-align: center;">S816-103001</p>
4	 <p style="text-align: center;">S816-004001</p>	 <p style="text-align: center;">S816-104001</p>
8	 <p style="text-align: center;">S816-008001</p>	 <p style="text-align: center;">S816-108001</p>

3) SWP TYPE CONNECTOR

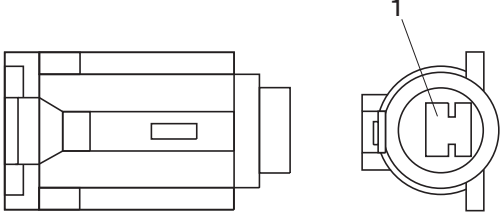
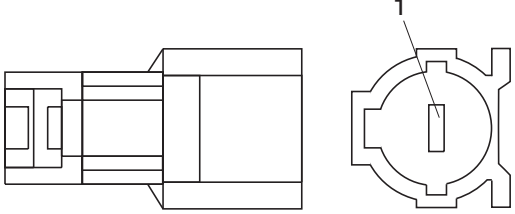
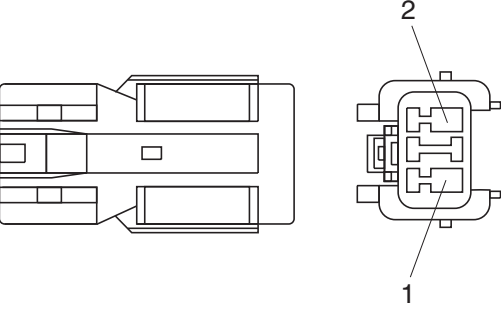
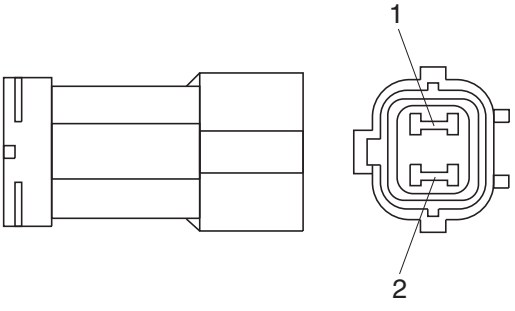
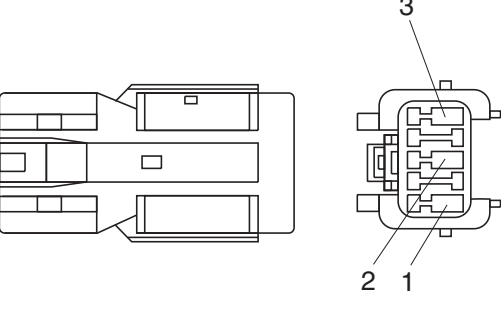
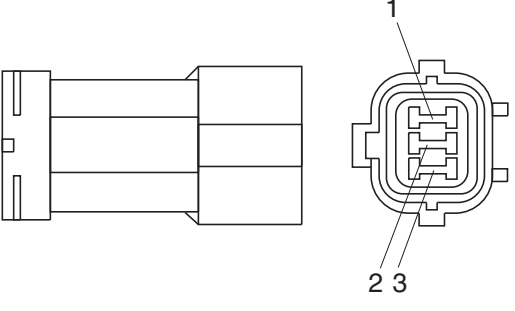
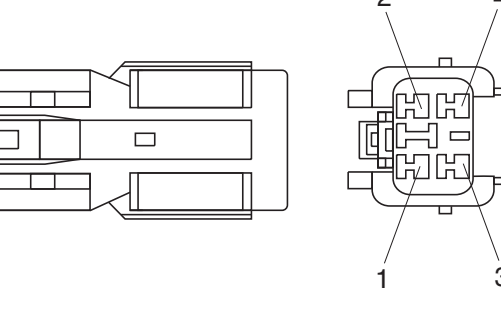
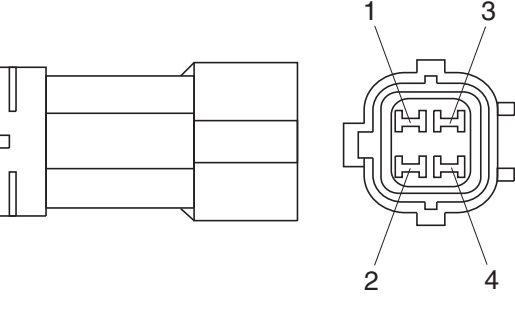
No. of pin	Receptacle connector (female)	Plug connector (male)
1	 <p data-bbox="687 680 836 707">S814-001000</p>	 <p data-bbox="1241 680 1390 707">S814-101000</p>
2	 <p data-bbox="687 1084 836 1111">S814-002000</p>	 <p data-bbox="1241 1084 1390 1111">S814-102000</p>
3	 <p data-bbox="687 1494 836 1520">S814-003000</p>	 <p data-bbox="1241 1494 1390 1520">S814-103000</p>
4	 <p data-bbox="687 1904 836 1930">S814-004000</p>	 <p data-bbox="1241 1904 1390 1930">S814-104000</p>

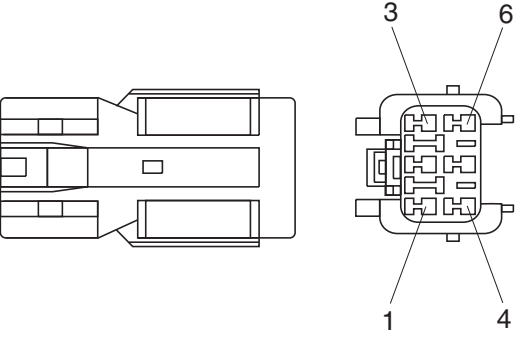
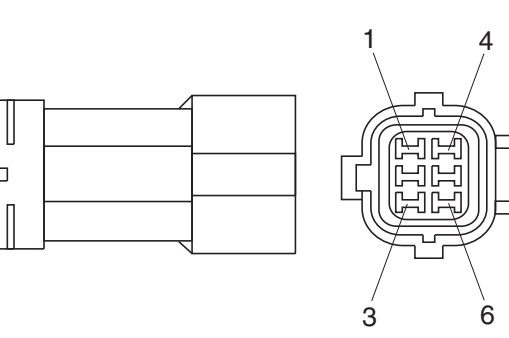
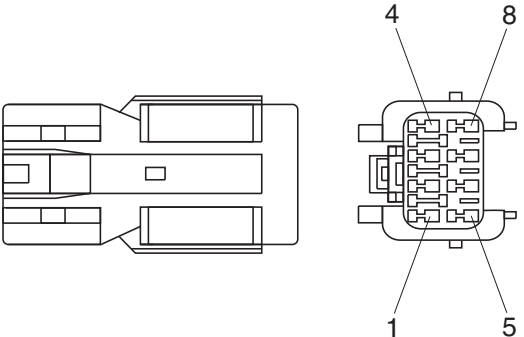
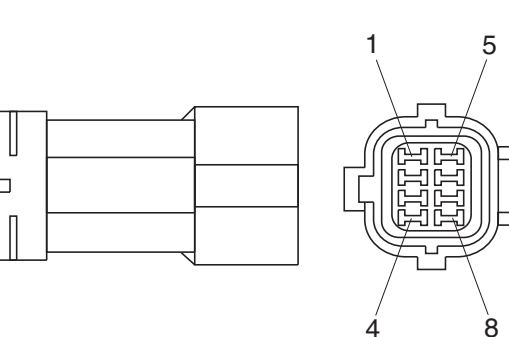
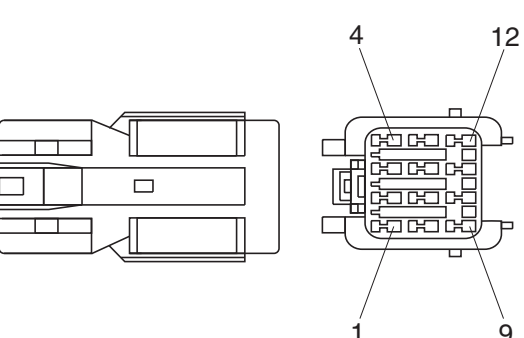
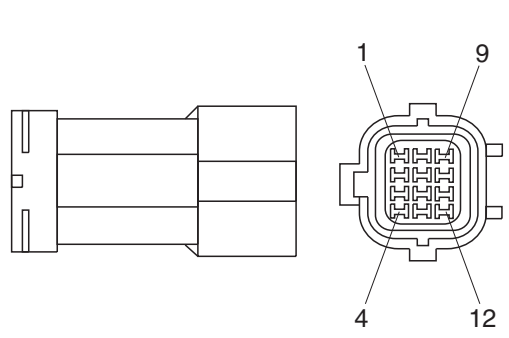
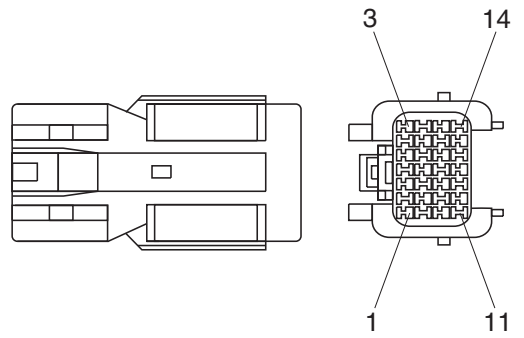
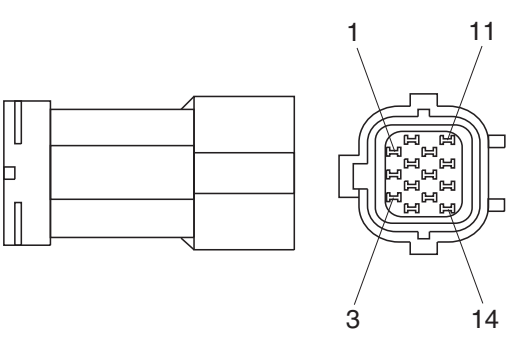
No. of pin	Receptacle connector (female)	Plug connector (male)
6	 <p data-bbox="686 638 837 672">S814-006000</p>	 <p data-bbox="1244 638 1396 672">S814-106000</p>
8	 <p data-bbox="686 1041 837 1075">S814-008000</p>	 <p data-bbox="1244 1041 1396 1075">S814-108000</p>
12	 <p data-bbox="686 1449 837 1482">S814-012000</p>	 <p data-bbox="1244 1449 1396 1482">S814-112000</p>
14	 <p data-bbox="686 1856 837 1890">S814-014000</p>	 <p data-bbox="1244 1856 1396 1890">S814-114000</p>

4) CN TYPE CONNECTOR

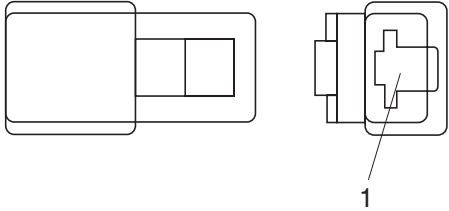
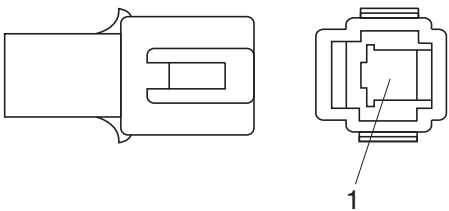
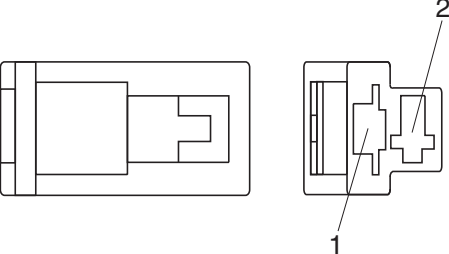
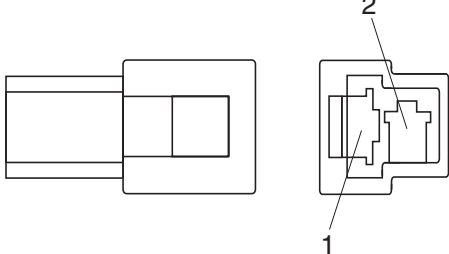
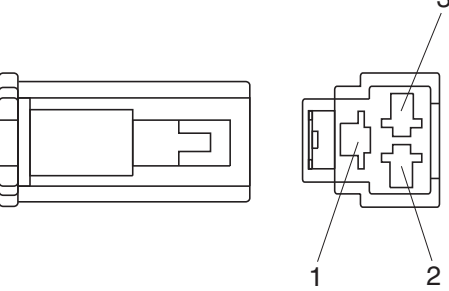
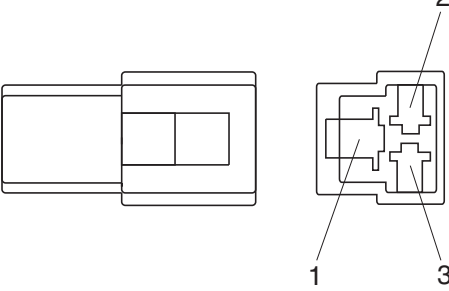
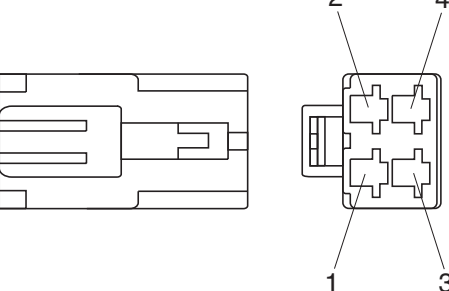
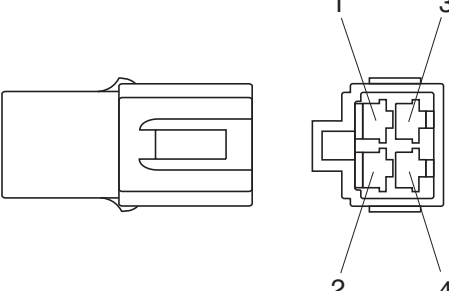
No. of pin	Receptacle connector (female)	Plug connector (male)
1	 <p style="text-align: center;">S810-001202</p>	 <p style="text-align: center;">S810-101202</p>
2	 <p style="text-align: center;">S810-002202</p>	 <p style="text-align: center;">S810-102202</p>
3	 <p style="text-align: center;">S810-003202</p>	 <p style="text-align: center;">S810-103202</p>
4	 <p style="text-align: center;">S810-004202</p>	 <p style="text-align: center;">S810-104202</p>

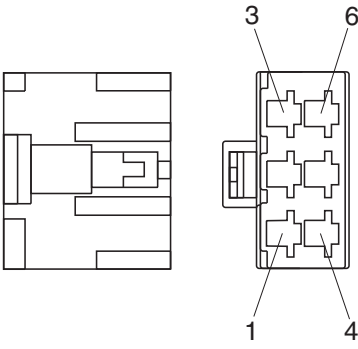
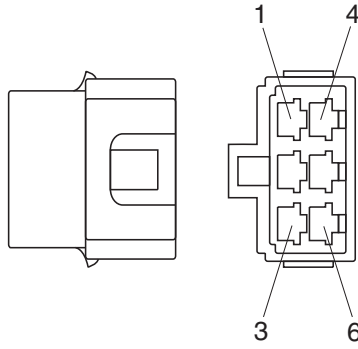
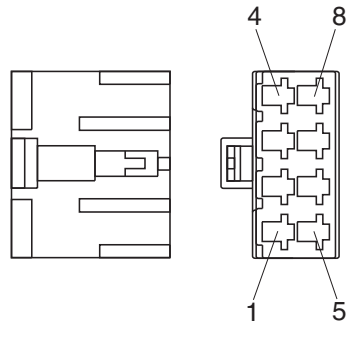
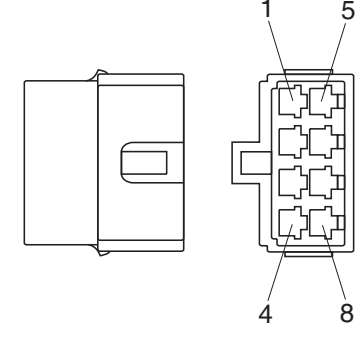
No. of pin	Receptacle connector (female)	Plug connector (male)
6	 <p data-bbox="686 638 837 672">S810-006202</p>	 <p data-bbox="1244 638 1396 672">S810-106202</p>
8	 <p data-bbox="686 1041 837 1075">S810-008202</p>	 <p data-bbox="1244 1041 1396 1075">S810-108202</p>

5) 375 FASTEN TYPE CONNECTOR

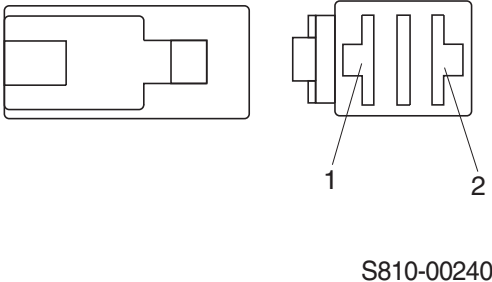
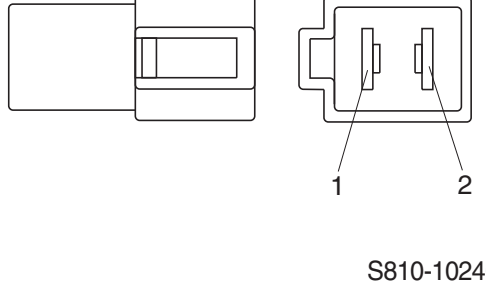
No. of pin	Receptacle connector (female)	Plug connector (male)
2	 <p style="text-align: center;">S810-002402</p>	 <p style="text-align: center;">S810-102402</p>

6) AMP ECONOSEAL CONNECTOR

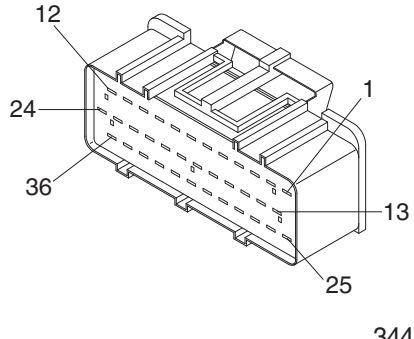
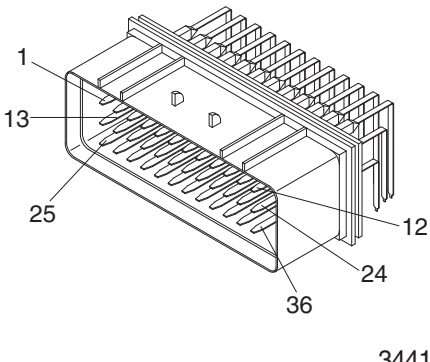
No. of pin	Receptacle connector (female)	Plug connector (male)
36	 <p style="text-align: center;">344111-1</p>	 <p style="text-align: center;">344108-1</p>

7) AMP TIMER CONNECTOR

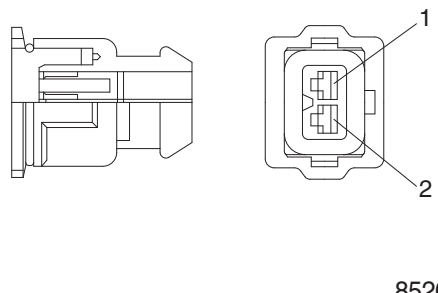
No. of pin	Receptacle connector (female)	Plug connector (male)
2	 <p style="text-align: center;">85202-1</p>	

8) AMP 040 MULTILOCK CONNECTOR

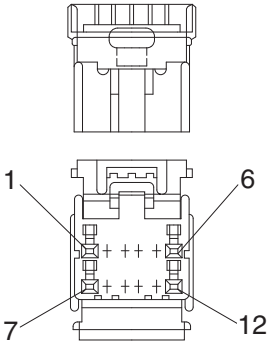
No. of pin	Receptacle connector (female)	Plug connector (male)
12		

9) AMP 070 MULTILOCK CONNECTOR

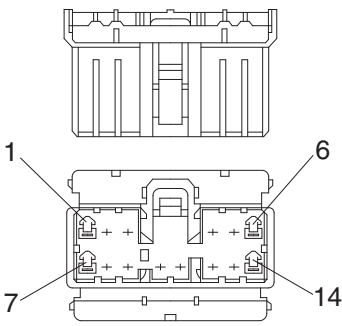
No. of pin	Receptacle connector (female)	Plug connector (male)
14		

10) AMP FASTIN - FASTON CONNECTOR

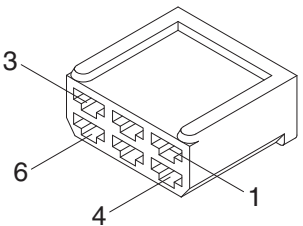
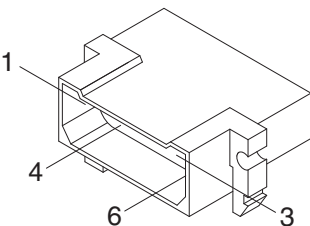
No. of pin	Receptacle connector (female)	Plug connector (male)
6		

11) KET 090 CONNECTOR

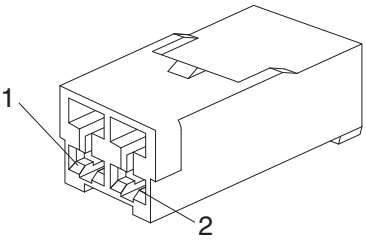
No. of pin	Receptacle connector (female)	Plug connector (male)
2	 <p style="text-align: right;">MG610070</p>	

12) KET 090 WP CONNECTORS

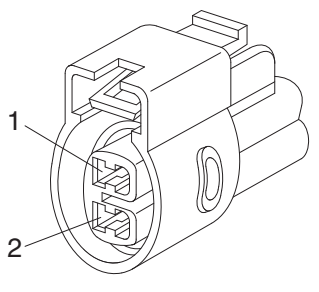
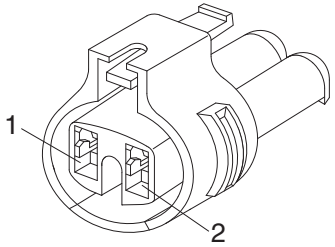
No. of pin	Receptacle connector (female)	Plug connector (male)
2	 <p style="text-align: right;">MG640605</p>	
2	 <p style="text-align: right;">MG640795</p>	

13) KET SDL CONNECTOR

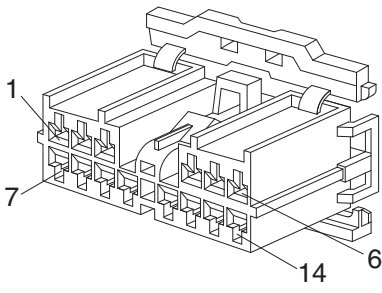
No. of pin	Receptacle connector (female)	Plug connector (male)
14	 <p>MG610406</p>	

14) DEUTSCH DT CONNECTORS

DT 06 - 3S - ★★☆☆

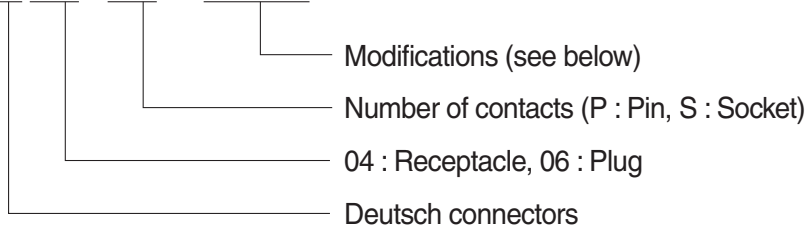

※ Modification

E003 : Standard end cap - gray

E004 : Color of connector to be black

E005 : Combination - E004 & E003

EP04 : End cap

EP06 : Combination P012 & EP04

P012 : Front seal enhancement - connectors color to black for 2, 3, 4 & 6pin

No. of pin	Receptacle connector (female)	Plug connector (male)
2	<p style="text-align: right;">DT06-2S</p>	<p style="text-align: right;">DT04-2P</p>
3	<p style="text-align: right;">DT06-3S</p>	<p style="text-align: right;">DT04-3P</p>
4	<p style="text-align: right;">DT06-4S</p>	<p style="text-align: right;">DT04-4P</p>

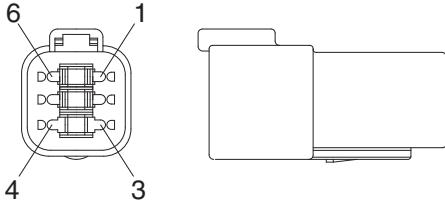
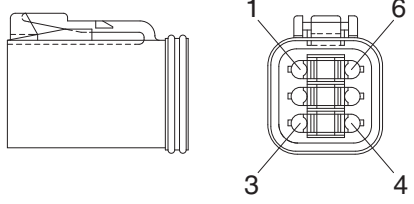
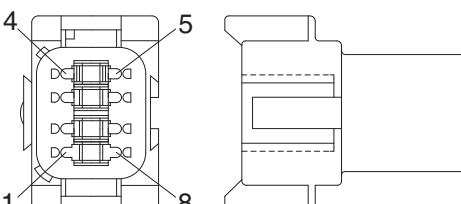
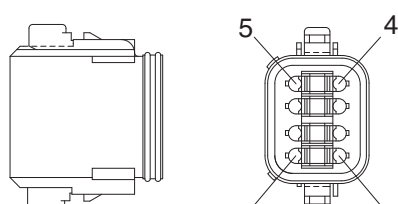
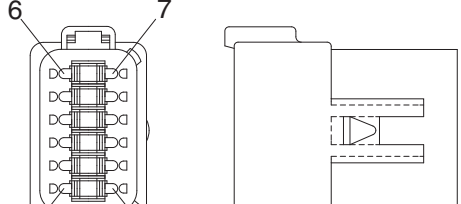
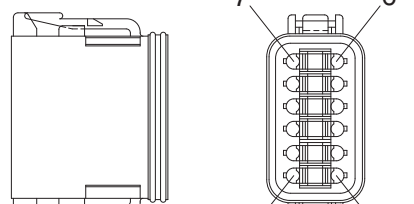
No. of pin	Receptacle connector (female)	Plug connector (male)
6	 <p style="text-align: right;">DT06-6S</p>	 <p style="text-align: right;">DT04-6P</p>
8	 <p style="text-align: right;">DT06-8S</p>	 <p style="text-align: right;">DT04-8P</p>
12	 <p style="text-align: right;">DT06-12S</p>	 <p style="text-align: right;">DT04-12P</p>

15) MOLEX 2CKTS CONNECTOR

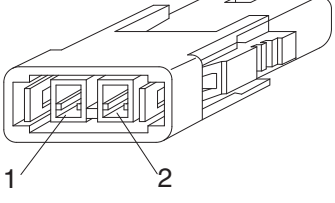
No. of pin	Receptacle connector (female)	Plug connector (male)
2	 <p data-bbox="702 683 837 705">35215-0200</p>	

16) ITT SWF CONNECTOR

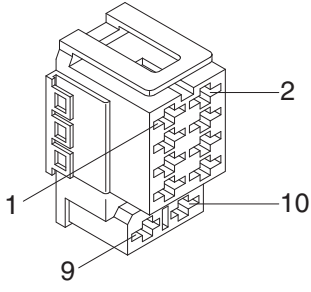
No. of pin	Receptacle connector (female)	Plug connector (male)
10	 <p data-bbox="694 1288 837 1310">SWF593757</p>	

17) MWP NMWP CONNECTOR

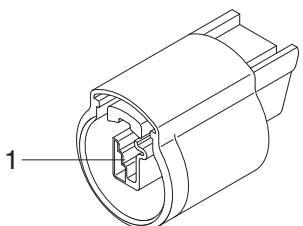
No. of pin	Receptacle connector (female)	Plug connector (male)
1	 <p data-bbox="686 1892 837 1915">NMWP01F-B</p>	

18) ECONOSEAL J TYPE CONNECTORS

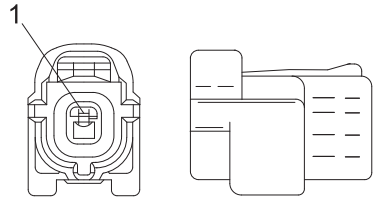
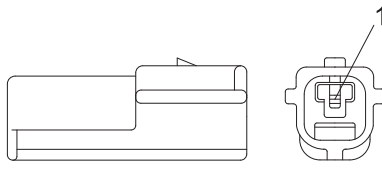
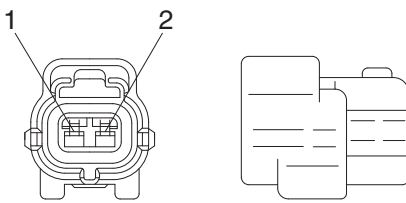
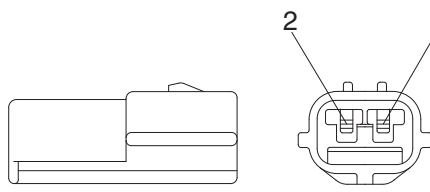
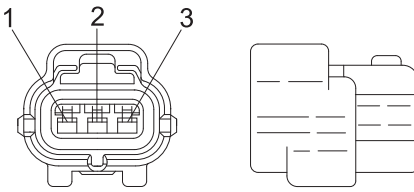
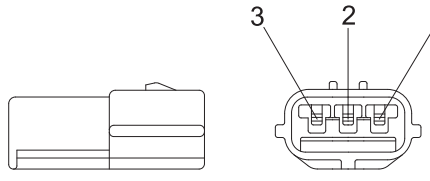
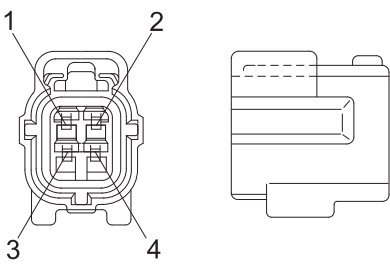
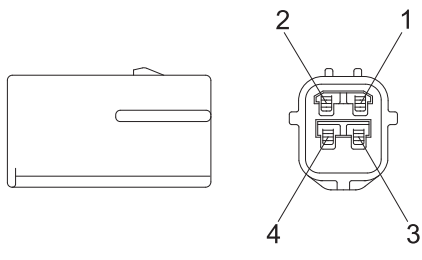
No. of pin	Receptacle connector (female)	Plug connector (male)
1	 <p style="text-align: center;">S816-001002</p>	 <p style="text-align: center;">S816-101002</p>
2	 <p style="text-align: center;">S816-002002</p>	 <p style="text-align: center;">S816-102002</p>
3	 <p style="text-align: center;">S816-003002</p>	 <p style="text-align: center;">S816-103002</p>
4	 <p style="text-align: center;">S816-004002</p>	 <p style="text-align: center;">S816-104002</p>

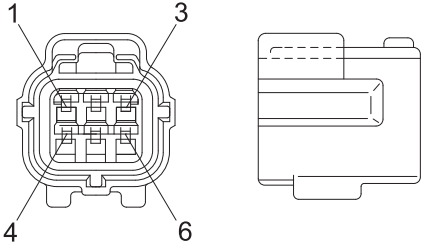
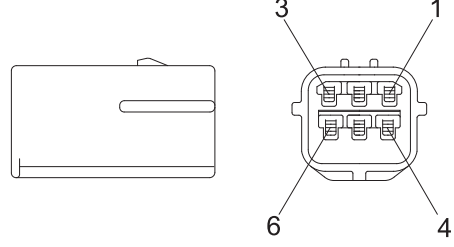
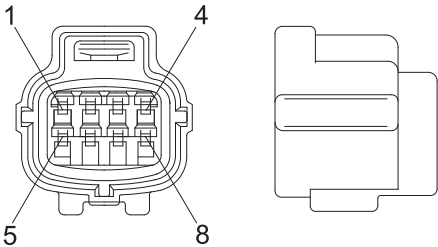
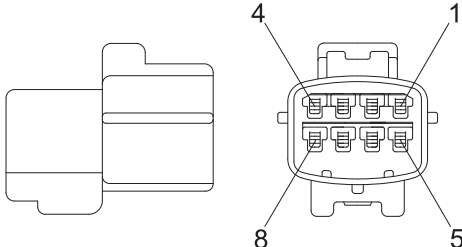
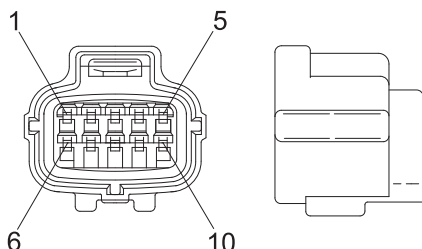
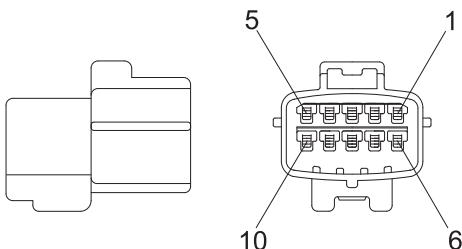
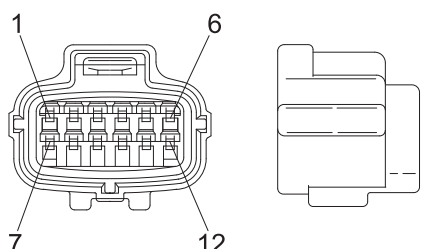
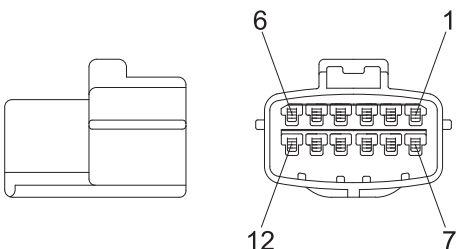
No. of pin	Receptacle connector (female)	Plug connector (male)
6	 <p data-bbox="686 638 837 672">S816-006002</p>	 <p data-bbox="1236 638 1388 672">S816-106002</p>
8	 <p data-bbox="686 1041 837 1075">S816-008002</p>	 <p data-bbox="1236 1041 1388 1075">S816-108002</p>
10	 <p data-bbox="686 1444 837 1478">S816-010002</p>	 <p data-bbox="1236 1444 1388 1478">S816-110002</p>
12	 <p data-bbox="686 1848 837 1881">S816-012002</p>	 <p data-bbox="1236 1848 1388 1881">S816-112002</p>

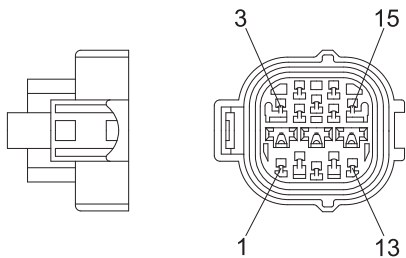
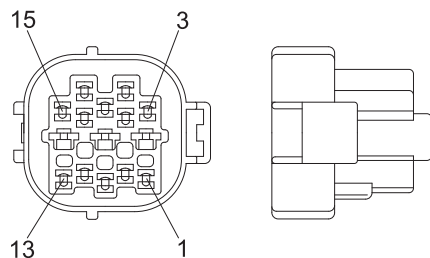
No. of pin	Receptacle connector (female)	Plug connector (male)
15	 <p style="text-align: right;">368301-1</p>	 <p style="text-align: right;">2-85262-1</p>

19) METRI-PACK TYPE CONNECTOR

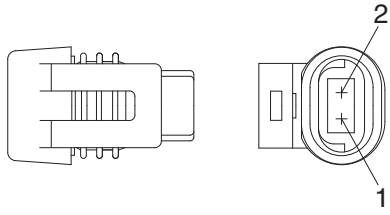
No. of pin	Receptacle connector (female)	Plug connector (male)
2	 <p style="text-align: right;">12040753</p>	

20) DEUTSCH HD30 CONNECTOR

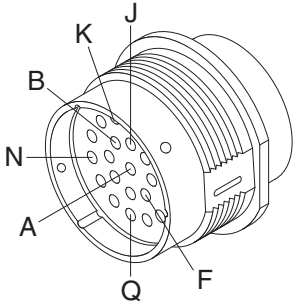
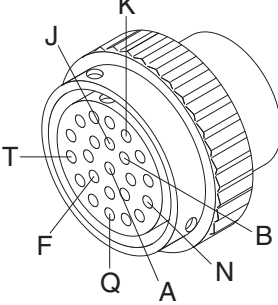
No. of pin	Receptacle connector (female)	Plug connector (male)
23	 <p style="text-align: right;">HD36-24-23SN</p>	 <p style="text-align: right;">HD34-24-23PN</p>

21) DEUTSCH MCU CONNECTOR

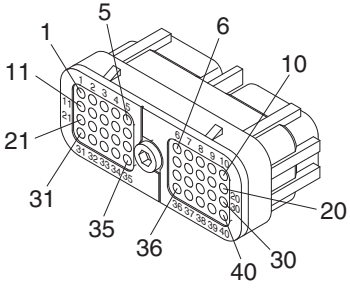
No. of pin	Receptacle connector (Female)	Plug connector (Male)
40	 <p style="text-align: right;">DRC26-40SA/B</p>	

22) DEUTSCH SERVICE TOOL CONNECTOR

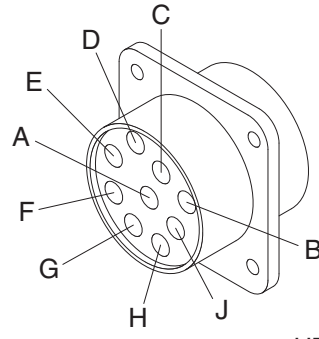
No. of pin	Receptacle connector (Female)	Plug connector (Male)
9	 <p style="text-align: right;">HD10-9-96P</p>	

23) AMP FUEL WARMER CONNECTOR

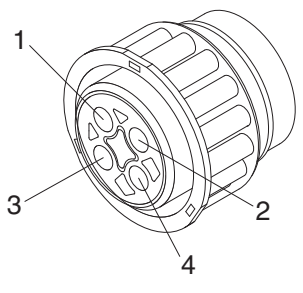
No. of pin	Receptacle connector (Female)	Plug connector (Male)
4	 <p style="text-align: right;">2-967325-3</p>	

24) DEUTSCH ENGINE ECM CONNECTOR

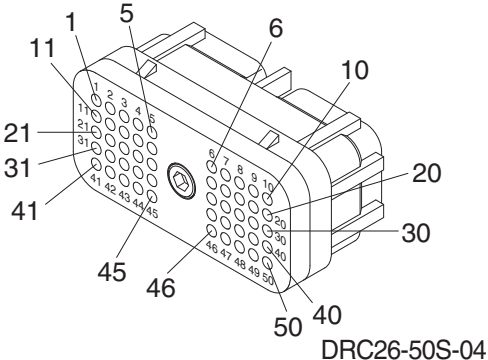
No. of pin	Receptacle connector (Female)	Plug connector (Male)
50	 <p style="text-align: right;">DRC26-50S-04</p>	

25) DEUTSCH INTERMEDIATE CONNECTOR

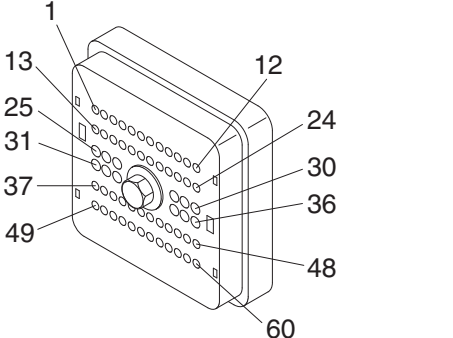
No. of pin	Receptacle connector (Female)	Plug connector (Male)
60	 <p style="text-align: right;">DRB16-60SAE-L018</p>	