

SECTION 1 GENERAL

Group 1 Safety Hints	1-1
Group 2 Specifications	1-10

SECTION 1 GENERAL

GROUP 1 SAFETY

FOLLOW SAFE PROCEDURE

Unsafe work practices are dangerous. Understand service procedure before doing work; Do not attempt shortcuts.

WEAR PROTECTIVE CLOTHING

Wear close fitting clothing and safety equipment appropriate to the job.

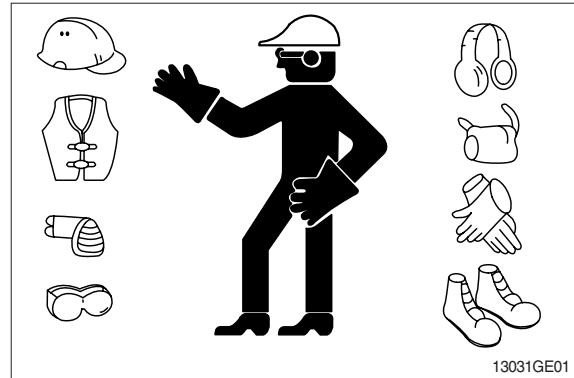

WARN OTHERS OF SERVICE WORK

Unexpected machine movement can cause serious injury.

Before performing any work on the excavator, attach a 「Do Not Operate」 tag on the right side control lever.

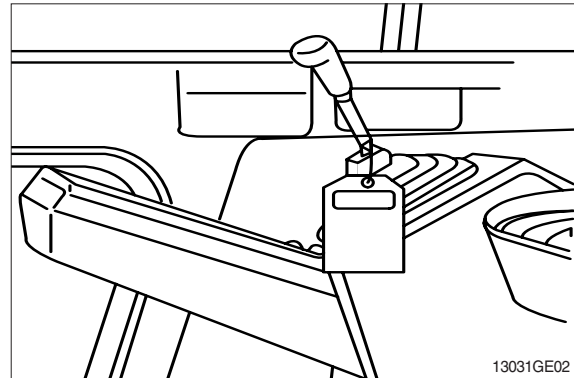

USE HANDHOLDS AND STEPS

Falling is one of the major causes of personal injury.

When you get on and off the machine, always maintain a three point contact with the steps and handrails and face the machine. Do not use any controls as handholds.

Never jump on or off the machine. Never mount or dismount a moving machine.

Be careful of slippery conditions on platforms, steps, and handrails when leaving the machine.

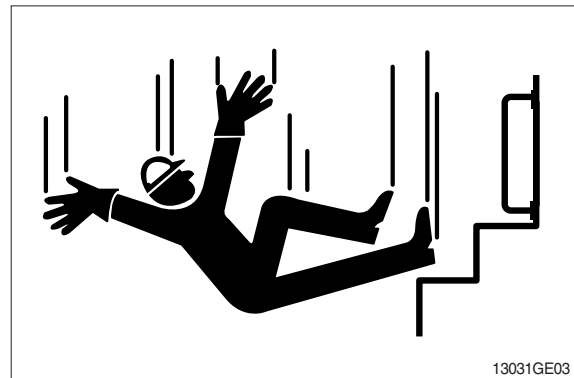

PREPARE FOR EMERGENCIES

Be prepared if a fire starts.

Keep a first aid kit and fire extinguisher handy.

Keep emergency numbers for doctors, ambulance service, hospital, and fire department near your telephone.

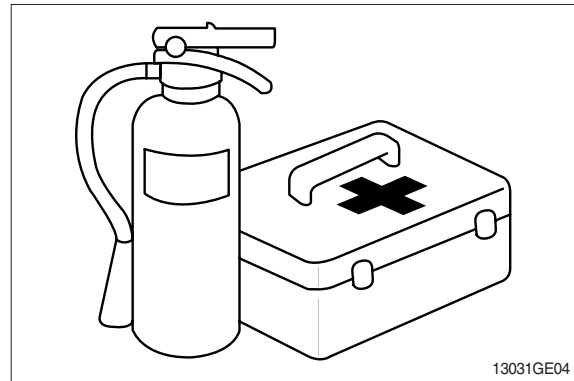

PROTECT AGAINST FLYING DEBRIS

Guard against injury from flying pieces of metal or debris; Wear goggles or safety glasses.

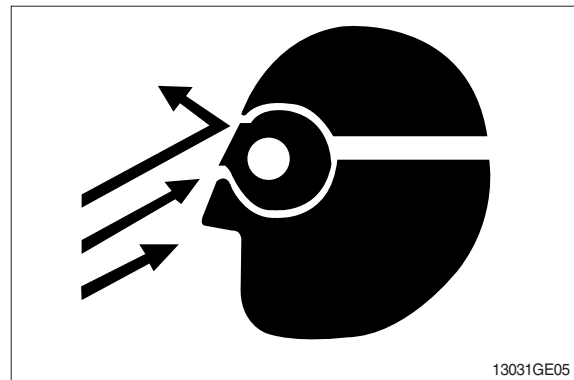

PROTECT AGAINST NOISE

Prolonged exposure to loud noise can cause impairment or loss of hearing.

Wear a suitable hearing protective device such as earmuffs or earplugs to protect against objectionable or uncomfortable loud noises.

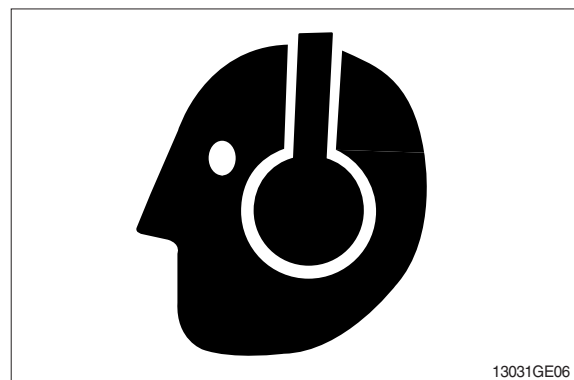

AVOID POWER LINES

Serious injury or death can result from contact with electric lines.

Never move any part of the machine or load closer to electric line than 3m(10ft) plus twice the line insulator length.

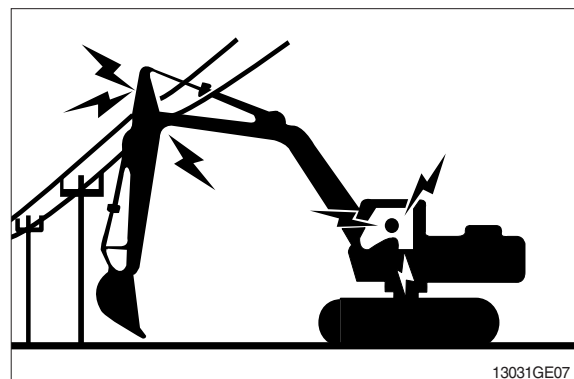

KEEP RIDERS OFF EXCAVATOR

Only allow the operator on the excavator. Keep riders off.

Riders on excavator are subject to injury such as being struck by foreign objects and being thrown off the excavator. Riders also obstruct the operator's view resulting in the excavator being operated in an unsafe manner.

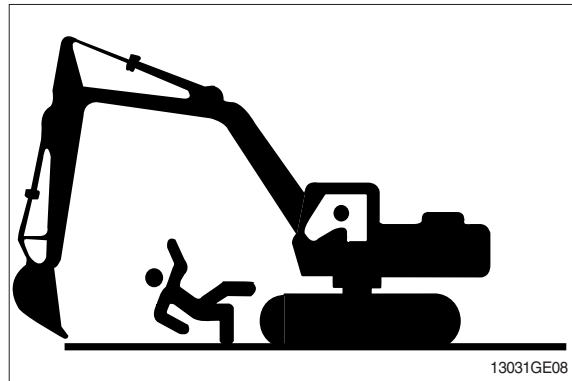

MOVE AND OPERATE MACHINE SAFELY

Bystanders can be run over. Know the location of bystanders before moving, swinging, or operating the machine.

Always keep the travel alarm in working condition. It warns people when the excavator starts to move.

Use a signal person when moving, swinging, or operating the machine in congested areas. Coordinate hand signals before starting the excavator.

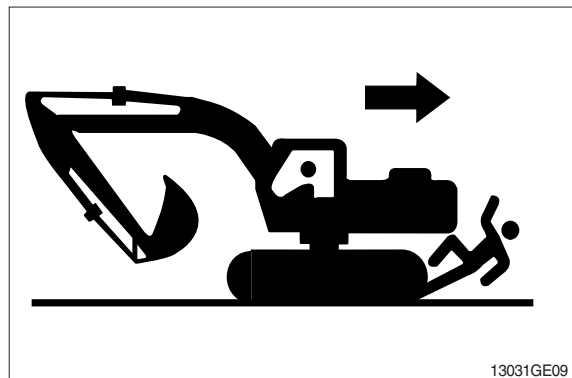

OPERATE ONLY FROM OPERATOR'S SEAT

Avoid possible injury machine damage. Do not start engine by shorting across starter terminals.

NEVER start engine while standing on ground. Start engine only from operator's seat.



PARK MACHINE SAFELY

Before working on the machine:

- Park machine on a level surface.
- Lower bucket to the ground.
- Turn auto idle switch off.
- Run engine at 1/2 speed without load for 2 minutes.
- Turn key switch to OFF to stop engine. Remove key from switch.
- Move pilot control shutoff lever to locked position.
- Allow engine to cool.

SUPPORT MACHINE PROPERLY

Always lower the attachment or implement to the ground before you work on the machine. If you must work on a lifted machine or attachment, securely support the machine or attachment.

Do not support the machine on cinder blocks, hollow tiles, or props that may crumble under continuous load.

Do not work under a machine that is supported solely by a jack. Follow recommended procedures in this manual.

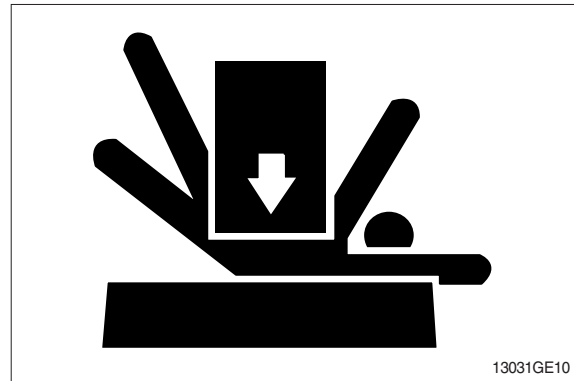

SERVICE COOLING SYSTEM SAFELY

Explosive release of fluids from pressurized cooling system can cause serious burns.

Shut off engine. Only remove filler cap when cool enough to touch with bare hands.

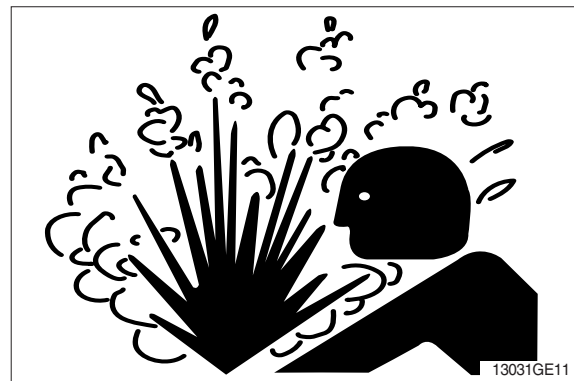

HANDLE FLUIDS SAFELY-AVOID FIRES

Handle fuel with care; It is highly flammable. Do not refuel the machine while smoking or when near open flame or sparks. Always stop engine before refueling machine. Fill fuel tank outdoors.

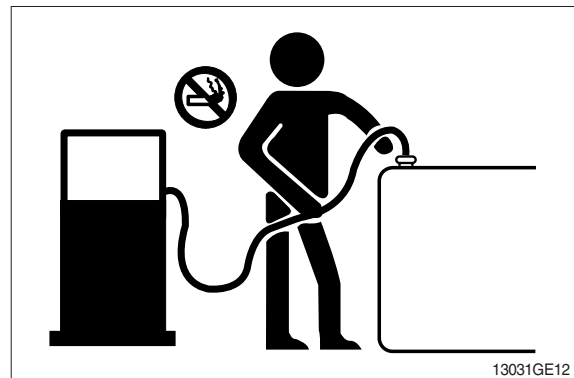

Store flammable fluids away from fire hazards. Do not incinerate or puncture pressurized containers.

Make sure machine is clean of trash, grease, and debris.

Do not store oily rags; They can ignite and burn spontaneously.

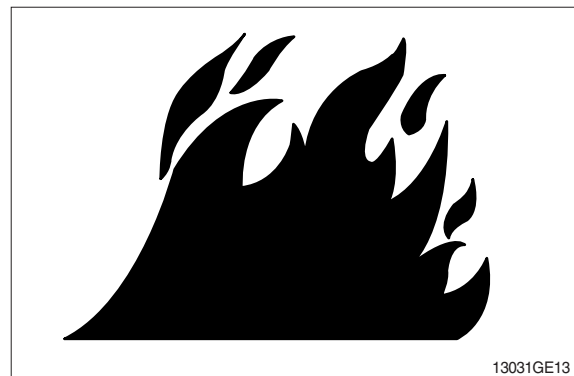

BEWARE OF EXHAUST FUMES

Prevent asphyxiation. Engine exhaust fumes can cause sickness or death.

If you must operate in a building, be positive there is adequate ventilation. Either use an exhaust pipe extension to remove the exhaust fumes or open doors and windows to bring enough outside air into the area.

REMOVE PAINT BEFORE WELDING OR HEATING

Avoid potentially toxic fumes and dust.

Hazardous fumes can be generated when paint is heated by welding, soldering, or using a torch.

Do all work outside or in a well ventilated area. Dispose of paint and solvent properly.

Remove paint before welding or heating:

- If you sand or grind paint, avoid breathing the dust.
Wear an approved respirator.
- If you use solvent or paint stripper, remove stripper with soap and water before welding. Remove solvent or paint stripper containers and other flammable material from area. Allow fumes to disperse at least 15 minutes before welding or heating.

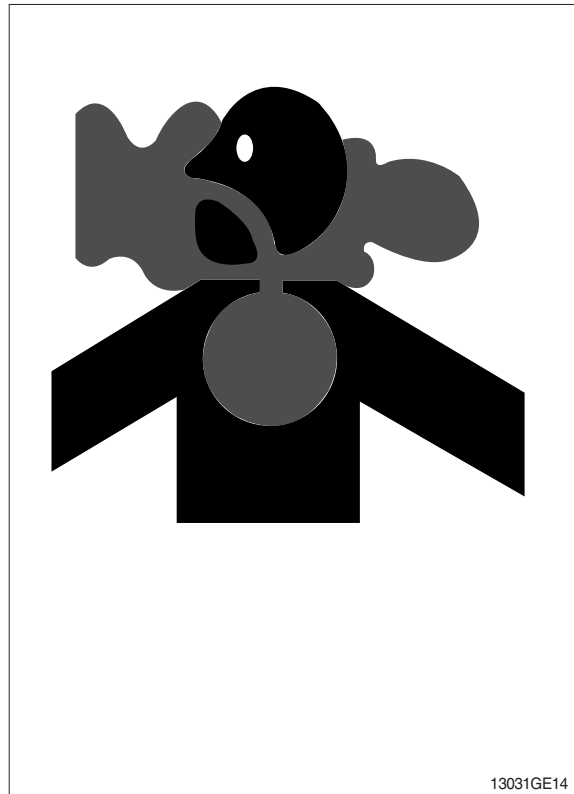

ILLUMINATE WORK AREA SAFELY

Illuminate your work area adequately but safely. Use a portable safety light for working inside or under the machine. Make sure the bulb is enclosed by a wire cage. The hot filament of an accidentally broken bulb can ignite spilled fuel or oil.



SERVICE MACHINE SAFELY

Tie long hair behind your head. Do not wear a necktie, scarf, loose clothing or necklace when you work near machine tools or moving parts. If these items were to get caught, severe injury could result.

Remove rings and other jewelry to prevent electrical shorts and entanglement in moving parts.

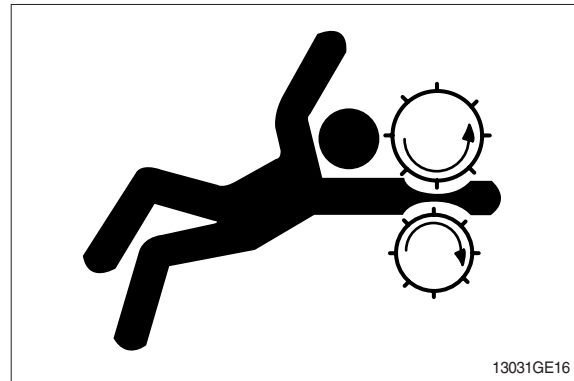

STAY CLEAR OF MOVING PARTS

Entanglements in moving parts can cause serious injury.

To prevent accidents, use care when working around rotating parts.

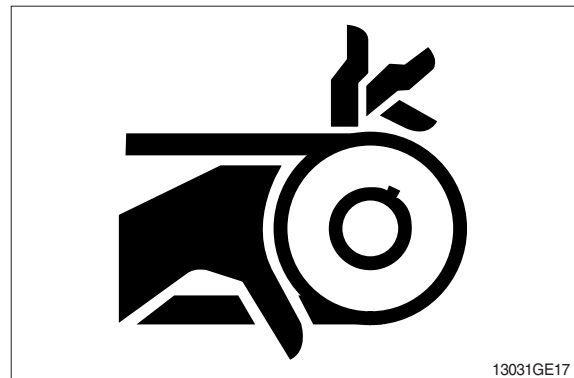

AVOID HIGH PRESSURE FLUIDS

Escaping fluid under pressure can penetrate the skin causing serious injury.

Avoid the hazard by relieving pressure before disconnecting hydraulic or other lines. Tighten all connections before applying pressure.

Search for leaks with a piece of cardboard. Protect hands and body from high pressure fluids.

If an accident occurs, see a doctor immediately. Any fluid injected into the skin must be surgically removed within a few hours or gangrene may result.

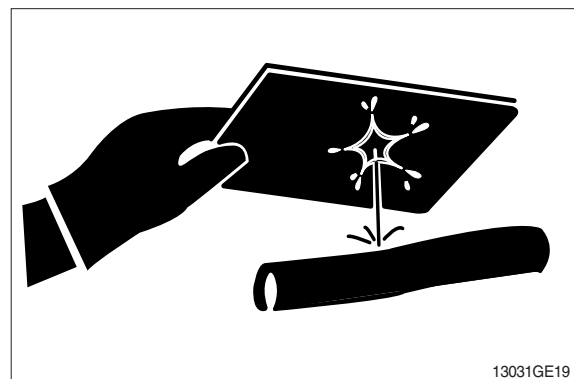

AVOID HEATING NEAR PRESSURIZED FLUID LINES

Flammable spray can be generated by heating near pressurized fluid lines, resulting in severe burns to yourself and bystanders. Do not heat by welding, soldering, or using a torch near pressurized fluid lines or other flammable materials.

Pressurized lines can be accidentally cut when heat goes beyond the immediate flame area. Install fire resisting guards to protect hoses or other materials.



PREVENT BATTERY EXPLOSIONS

Keep sparks, lighted matches, and flame away from the top of battery. Battery gas can explode.

Never check battery charge by placing a metal object across the posts. Use a volt-meter or hydrometer.

Do not charge a frozen battery; It may explode. Warm battery to 16°C (60°F).



PREVENT ACID BURNS

Sulfuric acid in battery electrolyte is poisonous. It is strong enough to burn skin, eat holes in clothing, and cause blindness if splashed into eyes.

Avoid the hazard by:

1. Filling batteries in a well-ventilated area.
2. Wearing eye protection and rubber gloves.
3. Avoiding breathing fumes when electrolyte is added.
4. Avoiding spilling or dripping electrolyte.
5. Use proper jump start procedure.

If you spill acid on yourself:

1. Flush your skin with water.
2. Apply baking soda or lime to help neutralize the acid.
3. Flush your eyes with water for 10-15 minutes. Get medical attention immediately.

If acid is swallowed:

1. Drink large amounts of water or milk.
2. Then drink milk of magnesia, beaten eggs, or vegetable oil.
3. Get medical attention immediately.

USE TOOLS PROPERLY

Use tools appropriate to the work. Makeshift tools, parts, and procedures can create safety hazards.

Use power tools only to loosen threaded tools and fasteners.

For loosening and tightening hardware, use the correct size tools. **DO NOT** use U.S. measurement tools on metric fasteners. Avoid bodily injury caused by slipping wrenches.

Use only recommended replacement parts. (See Parts catalogue.)

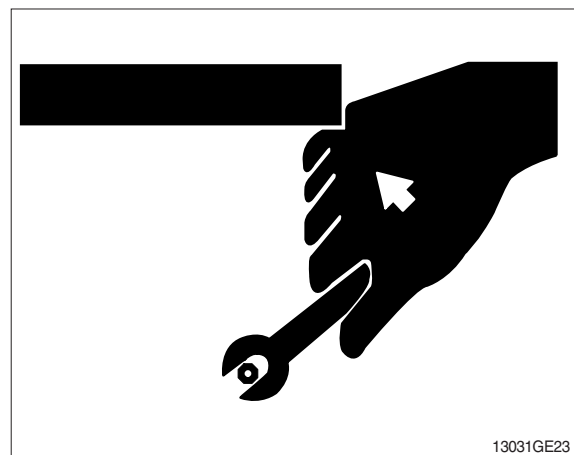
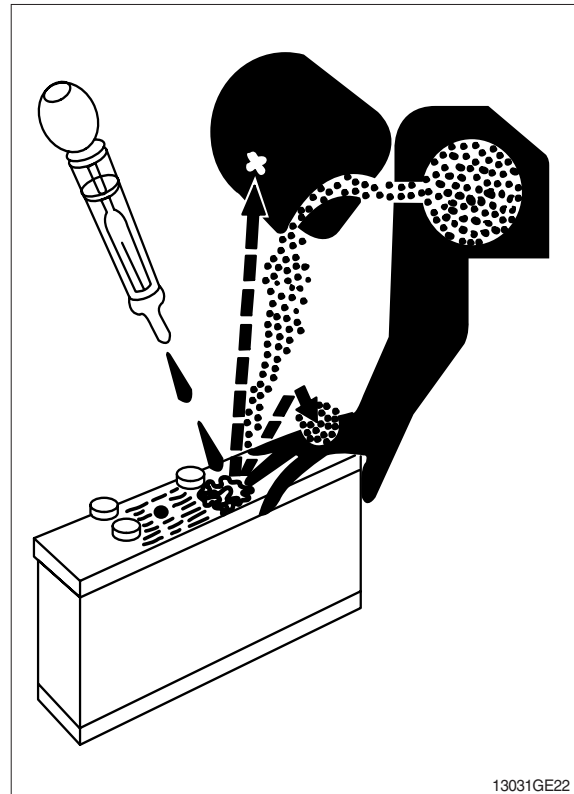

DISPOSE OF FLUIDS PROPERLY

Improperly disposing of fluids can harm the environment and ecology. Before draining any fluids, find out the proper way to dispose of waste from your local environmental agency.

Use proper containers when draining fluids. Do not use food or beverage containers that may mislead someone into drinking from them.

DO NOT pour oil into the ground, down a drain, or into a stream, pond, or lake. Observe relevant environmental protection regulations when disposing of oil, fuel, coolant, brake fluid, filters, batteries, and other harmful waste.

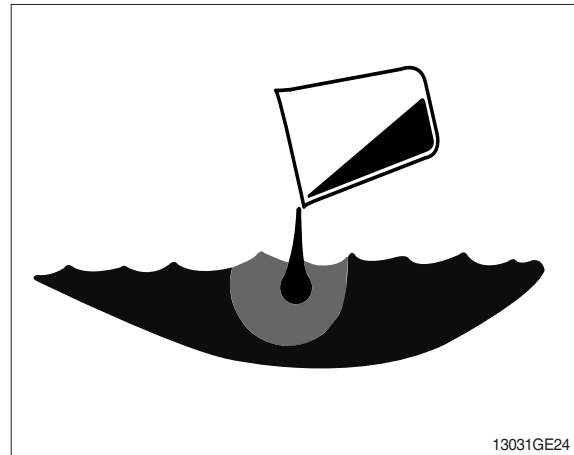

REPLACE SAFETY SIGNS

Replace missing or damaged safety signs. See the machine operator's manual for correct safety sign placement.

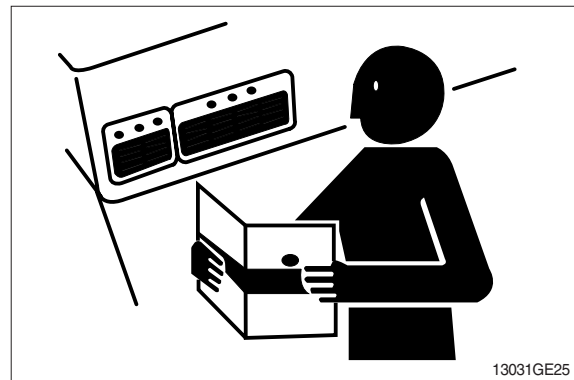

LIVE WITH SAFETY

Before returning machine to customer, make sure machine is functioning properly, especially the safety systems. Install all guards and shields.

GROUP 2 SPECIFICATIONS

1. MAJOR COMPONENT

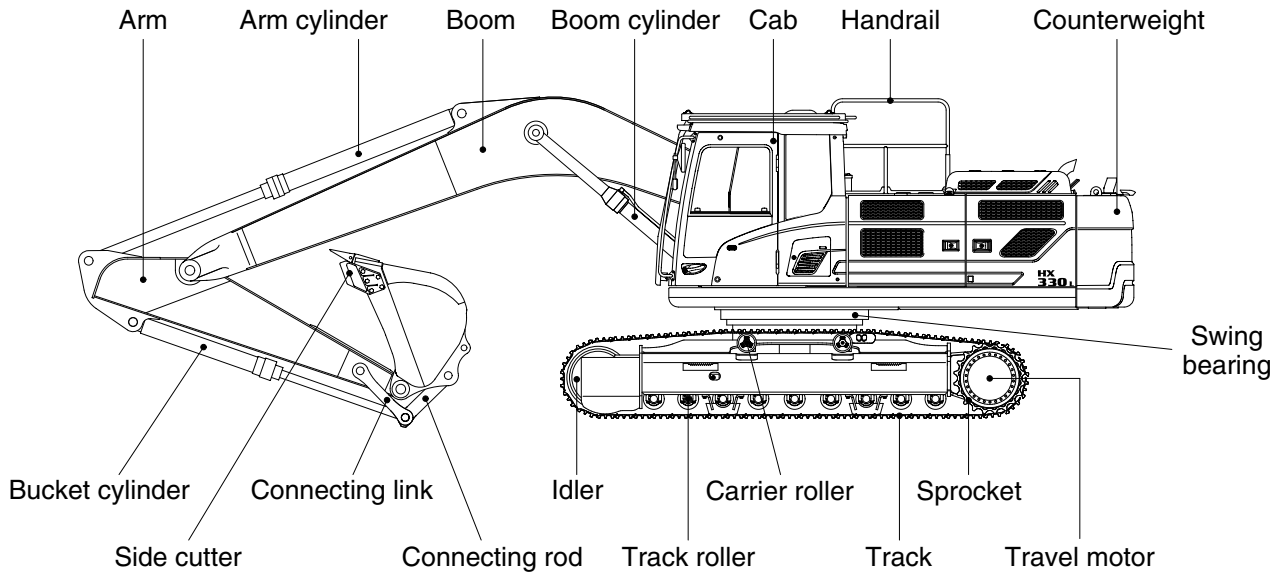
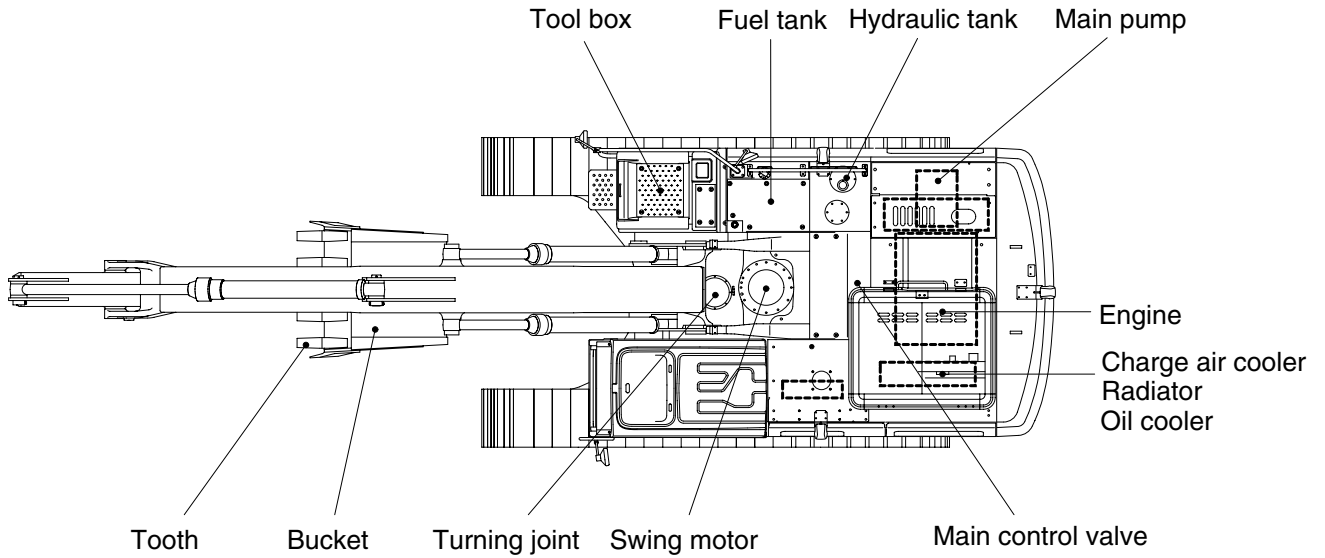

330S2SP01

2. SPECIFICATIONS

1)HX330S L

(1) 6.45 m (21' 2") boom and 3.20 m (10' 6") arm

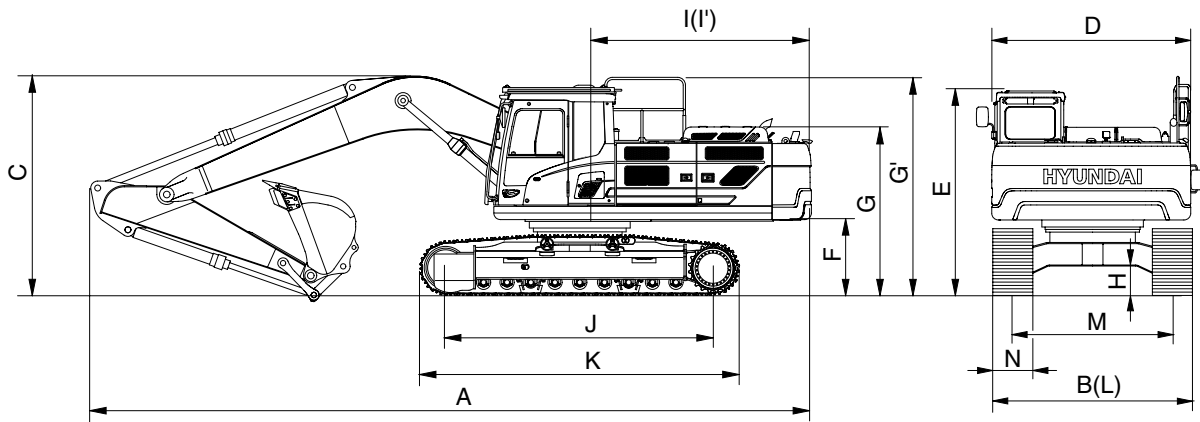

330S2SP02

Description		Unit	Specification
Operating weight		kg (lb)	33000 (72750)
Bucket capacity (SAE heaped), standard		m ³ (yd ³)	1.44 (1.88)
Overall length	A	mm (ft-in)	11220 (36' 10")
Overall width, with 600 mm shoe	B		3280 (10' 9")
Overall height of boom	C		3360 (11' 0")
Superstructure width	D		2980 (9' 9")
Overall height of cab	E		3145 (10' 4")
Ground clearance of counterweight	F		1200 (3' 11")
Overall height of engine hood	G		2672 (8' 9")
Overall height of handrail	G'		3350 (11' 0")
Minimum ground clearance	H		500 (1' 8")
Rear-end distance	I		3510 (11' 6")
Rear-end swing radius	I'		3570 (11' 9")
Distance between tumblers	J		4030 (13' 3")
Undercarriage length	K		4940 (16' 2")
Undercarriage width	L		3280 (10' 9")
Track gauge	M		2680 (8' 10")
Track shoe width, standard	N		600 (24")
Travel speed (low/high)		km/hr (mph)	3.6/6.4 (2.11/3.98)
Swing speed		rpm	11.2
Gradeability		Degree (%)	35 (70)
Ground pressure (600 mm shoe)		kgf/cm ² (psi)	0.64 (9.03)
Max traction force		kg (lb)	29500 (65030)

(2) 6.15 m (20' 2") boom and 2.2 m (7' 3") arm

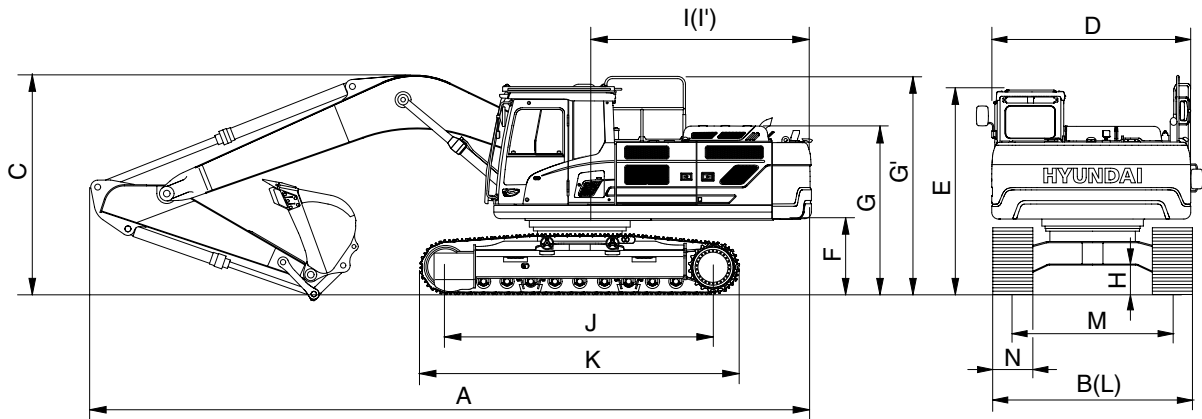

330S2SP02

Description	Unit	Specification
Operating weight	kg (lb)	32806 (72325)
Bucket capacity (SAE heaped), standard	m ³ (yd ³)	1.44 (1.88)
Overall length	A	11170 (36' 8")
Overall width, with 600 mm shoe	B	3280 (10' 9")
Overall height of boom	C	3680 (12' 1")
Superstructure width	D	2980 (9' 9")
Overall height of cab	E	3145 (10' 4")
Ground clearance of counterweight	F	1200 (3' 11")
Overall height of engine hood	G	2672 (8' 9")
Overall height of handrail	G'	3350 (11' 0")
Minimum ground clearance	H	500 (1' 8")
Rear-end distance	I	3510 (11' 6")
Rear-end swing radius	I'	3570 (11' 9")
Distance between tumblers	J	4030 (13' 3")
Undercarriage length	K	4940 (16' 2")
Undercarriage width	L	3280 (10' 9")
Track gauge	M	2680 (8' 10")
Track shoe width, standard	N	600 (24")
Travel speed (low/high)	km/hr (mph)	3.6/6.4 (2.11/3.98)
Swing speed	rpm	11.2
Gradeability	Degree (%)	35 (70)
Ground pressure (600 mm shoe)	kgf/cm ² (psi)	0.63 (8.98)
Max traction force	kg (lb)	29500 (65030)

3. WORKING RANGE

1)HX330S L

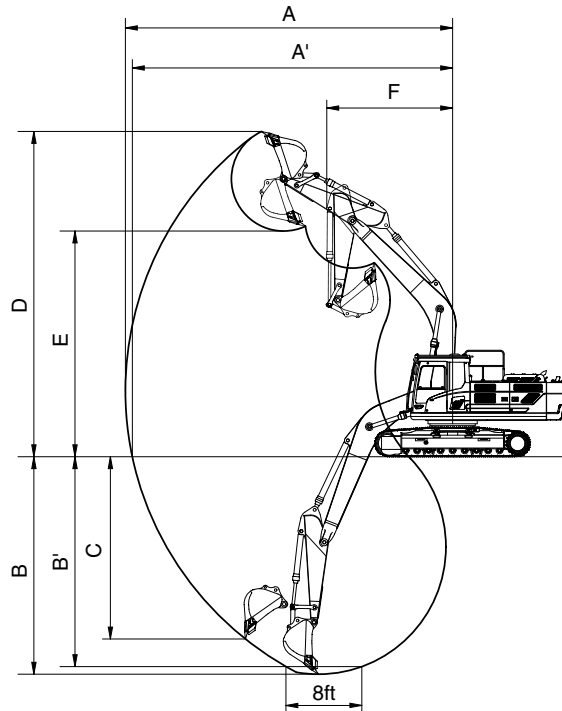

330S2SP05

Description	6.45 m (21' 2") Arm				6.15 m (20' 2") Boom	
		2.2 m (7' 3") Arm	2.5 m (8' 2") Arm	3.2 m (10' 6") Arm	4.05 m (13' 3") Arm	2.2 m (7' 3") Arm
Max digging reach	A	10330 mm (33'11")	10500 mm (34' 5")	11150 mm (36' 7")	11950 mm (39' 2")	10020 mm (32'10")
Max digging reach on ground	A'	10120 mm (33' 2")	10290 mm (33' 9")	10950 mm (35'11")	11770 mm (38' 7")	9810 mm (32' 2")
Max digging depth	B	6360 mm (20'10")	6660 mm (21'10")	7360 mm (24' 2")	8210 mm (26'11")	6150 mm (20' 2")
Max digging depth (8ft level)	B'	6170 mm (20' 3")	6450 mm (21' 2")	7200 mm (23' 7")	8080 mm (26' 6")	5950 mm (19' 6")
Max vertical wall digging depth	C	5970 mm (19' 7")	5660 mm (18' 7")	6330 mm (20' 9")	7240 mm (23' 9")	5700 mm (18' 8")
Max digging height	D	10260 mm (33' 8")	10050 mm (33' 0")	10360 mm (34' 0")	10780 mm (35' 4")	9980 mm (32' 9")
Max dumping height	E	7060 mm (23' 2")	6950 mm (22'10")	7260 mm (23'10")	7670 mm (25' 2")	6790 mm (22' 3")
Min swing radius	F	4630 mm (15' 2")	4440 mm (14' 7")	4360 mm (14' 4")	4290 mm (14' 1")	4450 mm (14' 7")
Bucket digging force	SAE	186.3 [203.3] kN	187.3 [204.4] kN	188.3 [205.5] kN	189.3 [206.4] kN	186.3 [203.3] kN
		19000 [20730] kgf	19100 [20840] kgf	19200 [20950] kgf	19300 [21050] kgf	19000 [20730] kgf
		41890 [45700] lbf	42110 [45940] lbf	42330 [46190] lbf	42550 [46410] lbf	41890 [45700] lbf
	ISO	214.8 [234.3] kN	215.7 [235.4] kN	216.7 [236.4] kN	217.7 [237.5] kN	214.8 [234.3] kN
		21900 [23890] kgf	22000 [24000] kgf	22100 [24110] kgf	22200 [24220] kgf	21900 [23890] kgf
		48280 [52670] lbf	48500 [52910] lbf	48720 [53150] lbf	48940 [53400] lbf	48280 [52670] lbf
Arm crowd force	SAE	195.2 [212.9] kN	175.5 [191.5] kN	140.2 [153.0] kN	118.7 [129.4] kN	195.2 [212.9] kN
		19900 [21710] kgf	17900 [19530] kgf	14300 [15600] kgf	12100 [13200] kgf	19900 [21710] kgf
		43870 [47860] lbf	39460 [43060] lbf	31530 [34390] lbf	26680 [29100] lbf	43870 [47860] lbf
	ISO	205.0 [223.6] kN	184.4 [201.1] kN	145.1 [158.4] kN	123.6 [134.8] kN	205.0 [223.6] kN
		20900 [22800] kgf	18800 [20510] kgf	14800 [16150] kgf	12600 [13750] kgf	20900 [22800] kgf
		46080 [50270] lbf	41450 [45220] lbf	32630 [35600] lbf	27780 [30310] lbf	46080 [50270] lbf

[] : Power boost

4. WEIGHT

1)HX330S L

Item	HX330S L	
	kg	lb
Upperstructure assembly	15420	33995
Main frame weld assembly	3910	8620
Engine assembly	617	1360
Main pump assembly	201	443
Main control valve assembly	220	485
Swing motor assembly	370	820
Hydraulic oil tank assembly	300	661
Fuel tank assembly	350	772
Counterweight	6000	13230
Cab assembly	422	930
Radiator assy	230	510
Oil cooler assy	80	180
Lower chassis assembly	11500	25350
Track frame weld assembly	3970	8750
Swing bearing	470	1040
Travel motor assembly	440	970
Turning joint	54	119
Tension cylinder	225	496
Idler	250	551
Sprocket	83	183
Carrier roller	35	77
Track roller	56	123
Track-chain assembly (600 mm standard triple grouser shoe)	1880	4145
Front attachment assembly (6.45 m boom, 3.2 m arm, 1.44 m ³ SAE heaped bucket)	6580	14510
6.45 m boom assembly	2560	5640
3.2 m arm assembly	1170	2580
1.44 m ³ SAE heaped bucket	1230	2710
Boom cylinder assembly	305	670
Arm cylinder assembly	380	840
Bucket cylinder assembly	265	580
Bucket control linkage assembly	370	820

5. LIFTING CAPACITIES

1) HX330S L

Unit : mm

Model	Boom	Boom	Arm	Counterweight	Shoe	Dozer		Outrigger	
	Type	Length	Length	Weight (kg)	Width	Front	Rear	Front	Rear
HX330S L	Mono	6150	2200	6000	600	-	-	-	-



: Rating over-front



: Rating over-side or 360 degree

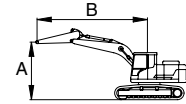

Load point height	Load radius												At max. reach			
	1.5 m (4.9 ft)		3.0 m (9.8 ft)		4.5 m (14.8 ft)		6.0 m (19.7 ft)		7.5 m (24.6 ft)		9.0 m (29.5 ft)		Capacity	Reach		
															m (ft)	
7.5m 24.6ft	kg lb							*9740 *21470	9610 21190					*9890 *21800	8800 19400	6.31 (20.7)
6.0m 19.7ft	kg lb							*9940 *21910	9490 20920					*9660 *21300	6770 14930	7.36 (24.2)
4.5m 14.8ft	kg lb							*11120 *24520	9120 20110	9690 21360	6480 14290			8710 19200	5830 12850	8.00 (26.2)
3.0m 9.8ft	kg lb							*12620 *27820	8680 19140	9480 20900	6290 13870			8080 17810	5380 11860	8.31 (27.3)
1.5m 4.9ft	kg lb							13020 28700	8330 18360	9280 20460	6110 13470			7930 17480	5260 11600	8.34 (27.4)
0.0m 0.0ft	kg lb							12810 28240	8150 17970	9170 20220	6010 13250			8230 18140	5440 11990	8.10 (26.6)
-1.5m -4.9ft	kg lb				*18500 *40790	12460 27470	12800 28220	8140 17950	9220 20330	6050 13340			9150 20170	6010 13250	7.54 (24.7)	
-3.0m -9.8ft	kg lb		*21230 *46800	*21230 *46800	*16370 *36090	12690 27980	*12350 *27230	8310 18320					*10680 *23550	7360 16230	6.60 (21.6)	

※ Note

- Lifting capacity are based on SAE J1097 and ISO 10567.
- Lifting capacity of the ROBEX series does not exceed 75% of tipping load with the machine on firm, level ground or 87% of full hydraulic capacity.
- The lift-point is bucket mounting pin on the arm (without bucket).
- *indicates load limited by hydraulic capacity.

※ Lifting capacities are based upon a standard machine conditions.

Lifting capacities will vary with different work tools, ground conditions and attachments.

The difference between the weight of a work tool attachment must be subtracted.

Consult your Hyundai dealer regarding the lifting capacities for specific work tools and attachments.

▲ Failure to comply to the rated load can cause possible personal injury or property damage.

Make adjustments to the rated load as necessary for non-standard configurations.









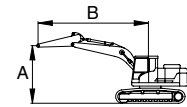





Unit : mm

Model	Boom	Boom	Arm	Counterweight	Shoe	Dozer		Outrigger	
	Type	Length	Length	Weight (kg)	Width	Front	Rear	Front	Rear
HX330S L	Mono	6450	2200	6000	600	-	-	-	-

·  : Rating over-front

·  : Rating over-side or 360 degree



Load point height		Load radius												At max. reach				
		1.5 m (4.9 ft)		3.0 m (9.8 ft)		4.5 m (14.8 ft)		6.0 m (19.7 ft)		7.5 m (24.6 ft)		9.0 m (29.5 ft)		Capacity		Reach		
																m (ft)		
7.5m	kg							*9270	*9270							*9420	7920	6.71
24.6ft	lb							*20440	*20440							*20770	17460	(22.0)
6.0m	kg							*9780	9400	*9190	6550					*9230	6240	7.71
19.7ft	lb							*21560	20720	*20260	14440					*20350	13760	(25.3)
4.5m	kg							*11070	8980	*9570	6410					8120	5420	8.32
14.8ft	lb							*24410	19800	*21100	14130					17900	11950	(27.3)
3.0m	kg							*12590	8510	9370	6190					7570	5030	8.62
9.8ft	lb							*27760	18760	20660	13650					16690	11090	(28.3)
1.5m	kg							12820	8160	9160	6000					7440	4920	8.65
4.9ft	lb							28260	17990	20190	13230					16400	10850	(28.4)
0.0m	kg							12630	7990	9050	5900					7700	5070	8.41
0.0ft	lb							27840	17610	19950	13010					16980	11180	(27.6)
-1.5m	kg				*18120	12280	12630	7990	9060	5910					8480	5560	7.88	
-4.9ft	lb				*39950	27070	27840	17610	19970	13030					18700	12260	(25.8)	
-3.0m	kg			*20410	*20410	*16200	12500	*12490	8140						*10120	6680	6.98	
-9.8ft	lb			*45000	*45000	*35710	27560	*27540	17950						*22310	14730	(22.9)	
-4.5m	kg				*12370	*12370									*9550	*9550	5.54	
-14.8ft	lb				*27270	*27270									*21050	*21050	(18.2)	

Unit : mm

Model	Boom	Boom	Arm	Counterweight	Shoe	Dozer		Outrigger	
	Type	Length	Length	Weight (kg)	Width	Front	Rear	Front	Rear
HX330S L	Mono	6450	2500	6000	600	-	-	-	-



: Rating over-front



: Rating over-side or 360 degree

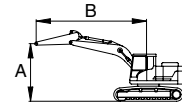

Load point height	Load radius												At max. reach			
	1.5 m (4.9 ft)		3.0 m (9.8 ft)		4.5 m (14.8 ft)		6.0 m (19.7 ft)		7.5 m (24.6 ft)		9.0 m (29.5 ft)		Capacity		Reach	
															m (ft)	
7.5m 24.6ft	kg lb													*8820 *19440	7570 16690	6.93 (22.7)
6.0m 19.7ft	kg lb						*9310 *20530	*9310 *20530	*8740 *19270	6590 14530				*8740 *19270	6020 13270	7.90 (25.9)
4.5m 14.8ft	kg lb				*13730 *30270	*13730 *30270	*10630 *23440	9020 19890	*9230 *20350	6410 14130				7860 17330	5240 11550	8.49 (27.9)
3.0m 9.8ft	kg lb						*12200 *26900	8520 18780	9360 20640	6180 13620				7330 16160	4860 10710	8.79 (28.8)
1.5m 4.9ft	kg lb						12800 28220	8130 17920	9130 20130	5960 13140				7190 15850	4740 10450	8.82 (28.9)
0.0m 0.0ft	kg lb				*15200 *33510	12060 26590	12570 27710	7930 17480	8990 19820	5830 12850				7410 16340	4860 10710	8.58 (28.2)
-1.5m -4.9ft	kg lb				*18400 *40570	12120 26720	12530 27620	7890 17390	8970 19780	5820 12830				8110 17880	5300 11680	8.06 (26.4)
-3.0m -9.8ft	kg lb		*21480 *47360	*21480 *47360	*16690 *36800	12330 27180	12670 27930	8020 17680					9700 21380	6300 13890	7.19 (23.6)	
-4.5m -14.8ft	kg lb				*13340 *29410	12750 28110							*10060 *22180	8800 19400	5.80 (19.0)	









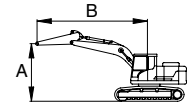





Unit : mm

Model	Boom	Boom	Arm	Counterweight	Shoe	Dozer		Outrigger	
	Type	Length	Length	Weight (kg)	Width	Front	Rear	Front	Rear
HX330S L	Mono	6450	3200	6000	600	-	-	-	-

•  : Rating over-front

•  : Rating over-side or 360 degree



Load point height		Load radius												At max. reach		
		1.5 m (4.9 ft)		3.0 m (9.8 ft)		4.5 m (14.8 ft)		6.0 m (19.7 ft)		7.5 m (24.6 ft)		9.0 m (29.5 ft)		Capacity		Reach
																m (ft)
7.5m	kg									*6830	6770			*5610	*5610	7.74
24.6ft	lb									*15060	14930			*12370	*12370	(25.4)
6.0m	kg									*7870	6710			*5430	5270	8.62
19.7ft	lb									*17350	14790			*11970	11620	(28.3)
4.5m	kg				*11980	*11980	*9660	9210	*8520	6500	*6670	4820	*5450	4660	9.17	
14.8ft	lb				*26410	*26410	*21300	20300	*18780	14330	*14700	10630	*12020	10270	(30.1)	
3.0m	kg				*15550	13250	*11360	8680	*9400	6240	7090	4700	*5650	4350	9.44	
9.8ft	lb				*34280	29210	*25040	19140	*20720	13760	15630	10360	*12460	9590	(31.0)	
1.5m	kg				*17440	12390	*12870	8220	9160	5990	6960	4580	*6050	4240	9.47	
4.9ft	lb				*38450	27320	*28370	18120	20190	13210	15340	10100	*13340	9350	(31.1)	
0.0m	kg				*17250	12040	12590	7940	8970	5810	6870	4500	6600	4320	9.25	
0.0ft	lb				*38030	26540	27760	17500	19780	12810	15150	9920	14550	9520	(30.4)	
-1.5m	kg			*10800	*10800	*18950	11990	12460	7820	8880	5730			7110	4650	8.77
-4.9ft	lb			*23810	*23810	*41780	26430	27470	17240	19580	12630			15670	10250	(28.8)
-3.0m	kg			*17460	*17460	*17750	12120	12510	7870	8940	5790			8210	5350	7.98
-9.8ft	lb			*38490	*38490	*39130	26720	27580	17350	19710	12760			18100	11790	(26.2)
-4.5m	kg			*20680	*20680	*15250	12440	*11460	8100					*9640	6910	6.76
-14.8ft	lb			*45590	*45590	*33620	27430	*25260	17860					*21250	15230	(22.2)









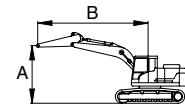





Unit : mm

Model	Boom	Boom	Arm	Counterweight	Shoe	Dozer		Outrigger	
	Type	Length	Length	Weight (kg)	Width	Front	Rear	Front	Rear
HX330S L	Mono	6450	4050	6000	600	-	-	-	-

•  : Rating over-front

•  : Rating over-side or 360 degree



Load point height	Load radius												At max. reach				
	1.5 m (4.9 ft)		3.0 m (9.8 ft)		4.5 m (14.8 ft)		6.0 m (19.7 ft)		7.5 m (24.6 ft)		9.0 m (29.5 ft)		Capacity		Reach		
															m (ft)		
7.5m 24.6ft	kg														*4200	*4200	8.72
	lb														*9260	*9260	(28.6)
6.0m 19.7ft	kg							*6810	*6810	*5820	4970	*4070	*4070	9.50			
	lb							*15010	*15010	*12830	10960	*8970	*8970	(31.2)			
4.5m 14.8ft	kg							*7560	6600	*7140	4860	*4080	4020	10.00			
	lb							*16670	14550	*15740	10710	*8990	8860	(32.8)			
3.0m 9.8ft	kg				*13330	*13330	*10120	8860	*8540	6290	7110	4710	*4210	3760	10.25		
	lb				*29390	*29390	*22310	19530	*18830	13870	15670	10380	*9280	8290	(33.6)		
1.5m 4.9ft	kg				*16570	12650	*11870	8300	9180	5990	6930	4540	*4460	3670	10.28		
	lb				*36530	27890	*26170	18300	20240	13210	15280	10010	*9830	8090	(33.7)		
0.0m 0.0ft	kg			*6350	*6350	*18440	12020	12580	7910	8920	5750	6780	4400	*4880	3720	10.08	
	lb			*14000	*14000	*40650	26500	27730	17440	19670	12680	14950	9700	*10760	8200	(33.1)	
-1.5m -4.9ft	kg	*6460	*6460	*9880	*9880	*18970	11790	12340	7690	8760	5600	6700	4330	*5560	3940	9.64	
	lb	*14240	*14240	*21780	*21780	*41820	25990	27210	16950	19310	12350	14770	9550	*12260	8690	(31.6)	
-3.0m -9.8ft	kg	*10380	*10380	*14460	*14460	*18440	11810	12290	7650	8730	5580			*6730	4420	8.92	
	lb	*22880	*22880	*31880	*31880	*40650	26040	27090	16870	19250	12300			*14840	9740	(29.3)	
-4.5m -14.8ft	kg	*15030	*15030	*20820	*20820	*16780	12020	12430	7770	8870	5700			8320	5380	7.86	
	lb	*33140	*33140	*45900	*45900	*36990	26500	27400	17130	19550	12570			18340	11860	(25.8)	
-6.0m -19.7ft	kg			*18490	*18490	*13330	12470	*9580	8140					*8920	7700	6.26	
	lb			*40760	*40760	*29390	27490	*21120	17950					*19670	16980	(20.5)	

6. BUCKET SELECTION GUIDE

1) GENERAL BUCKET

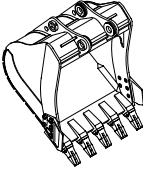
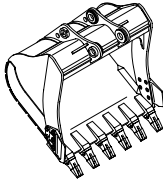
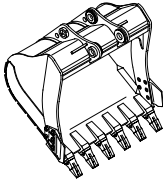
		
1.44 m ³ SAE heaped bucket	1.74 m ³ SAE heaped bucket	2.10 m ³ SAE heaped bucket

Capacity		Width		Weight	Recommendation				
					6.45 m (21' 2") boom				6.15 m (20' 2") boom
SAE heaped	CECE heaped	Without side cutter	With side cutter		2.2 m arm (7' 3")	2.5 m arm (8' 2")	3.2 m arm (10' 6")	4.05 m arm (13' 3")	2.2 m arm (7' 3")
1.44 m ³ (1.88 yd ³)	1.25 m ³ (1.63 yd ³)	1380 mm (54")	1500 mm (59")	1150 kg (2540 lb)	●	●	●	■	●
1.74 m ³ (2.28 yd ³)	1.50 m ³ (1.96 yd ³)	1620 mm (64")	1740 mm (69")	1260 kg (2780 lb)	◐	◐	■	▲	●
2.10 m ³ (2.75 yd ³)	1.80 m ³ (2.35 yd ³)	1910 mm (75")	2030 mm (80")	1650 kg (3640 lb)	■	■	▲	X	■

●	Applicable for materials with density of 2100 kg/m ³ (3500 lb/yd ³) or less
◐	Applicable for materials with density of 1800 kg/m ³ (3000 lb/yd ³) or less
■	Applicable for materials with density of 1500 kg/m ³ (2500 lb/yd ³) or less
▲	Applicable for materials with density of 1200 kg/m ³ (2000 lb/yd ³) or less
X	Not recommended

※ These recommendations are for general conditions and average use.

Work tools and ground conditions have effects on machine performance.

Select an optimum combination according to the working conditions and the type of work that is being done.

Consult your Hyundai dealer for information on selecting the correct boom–arm–bucket combination.

2) HEAVY DUTY AND ROCK-HEAVY DUTY BUCKET

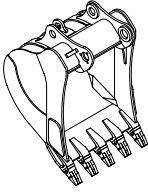
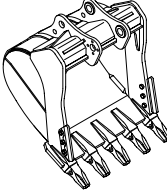
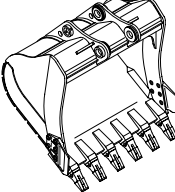
		
◆ 1.44 m ³ SAE heaped bucket	◆ 1.44 m ³ SAE ◆ 1.60 m ³ SAE ◆ 1.73 m ³ SAE heaped bucket	◆ 1.83 m ³ SAE heaped bucket

Capacity		Width		Weight	Recommendation				
					6.45 m (21' 2") boom				6.15 m (20' 2") boom
SAE heaped	CECE heaped	Without side cutter	With side cutter		2.2 m arm (7' 3")	2.5 m arm (8' 2")	3.2 m arm (10' 6")	4.05 m arm (13' 3")	2.2 m arm (7' 3")
◆ 1.44 m ³ (1.88 yd ³)	1.25 m ³ (1.63 yd ³)	1470 mm (58")	-	1410 kg (3110 lb)	●	●	◐	■	●
◆ 1.44 m ³ (1.88 yd ³)	1.25 m ³ (1.63 yd ³)	1470 mm (58")	-	1485 kg (3270 lb)	●	●	◐	X	●
◆ 1.60 m ³ (2.09 yd ³)	1.39 m ³ (1.82 yd ³)	1585 mm (62")	-	1650 kg (3640 lb)	●	◐	■	X	●
◆ 1.73 m ³ (2.26 yd ³)	1.5 m ³ (1.96 yd ³)	1710 mm (67")	-	1675 kg (3690 lb)	◐	◐	■	X	●
◆ 1.83 m ³ (2.39 yd ³)	1.59 m ³ (2.08 yd ³)	1765 mm (69")	-	1850 kg (4080 lb)	■	■	▲	X	◐

◆ : Heavy duty bucket

◆ : Rock-Heavy duty bucket

●	Applicable for materials with density of 2100 kg/m ³ (3500 lb/yd ³) or less
◐	Applicable for materials with density of 1800 kg/m ³ (3000 lb/yd ³) or less
■	Applicable for materials with density of 1500 kg/m ³ (2500 lb/yd ³) or less
▲	Applicable for materials with density of 1200 kg/m ³ (2000 lb/yd ³) or less
X	Not recommended

7. UNDERCARRIAGE

1) TRACKS

X-leg type center frame is integrally welded with reinforced box-section track frames. The design includes dry tracks, lubricated rollers, idlers, sprockets, hydraulic track adjusters with shock absorbing springs and assembled track-type tractor shoes with triple grousers.

2) TYPES OF SHOES

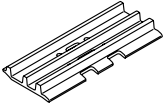
Model	Shapes		Triple grouser		
					
HX330S L	Shoe width	mm (in)	600 (24)	700 (28)	800 (32)
	Operating weight	kg (lb)	33000 (72750)	33570 (74010)	33950 (74850)
	Ground pressure	kgf/cm ² (psi)	0.64 (9.03)	0.55 (7.88)	0.49 (6.97)
	Overall width	mm (ft-in)	3280 (10' 9")	3380 (11' 1")	3480 (11' 5")

3) NUMBER OF ROLLERS AND SHOES ON EACH SIDE

Item	Quantity
Carrier rollers	2EA
Track rollers	9EA
Track shoes	48EA

4) SELECTION OF TRACK SHOE

Suitable track shoes should be selected according to operating conditions.

Method of selecting shoes

Confirm the category from the list of applications in **table 2**, then use **table 1** to select the shoe. Wide shoes (categories B and C) have limitations on applications. Before using wide shoes, check the precautions, then investigate and study the operating conditions to confirm if these shoes are suitable.

Select the narrowest shoe possible to meet the required flotation and ground pressure. Application of wider shoes than recommendations will cause unexpected problem such as bending of shoes, crack of link, breakage of pin, loosening of shoe bolts and the other various problems.

※ **Table 1**

Track shoe	Specification	Category
600 mm triple grouser	Standard	A
700 mm triple grouser	Option	B
800 mm triple grouser	Option	C

※ **Table 2**

Category	Applications	Applications
A	Rocky ground, river beds, normal soil	<ul style="list-style-type: none"> Travel at low speed on rough ground with large obstacles such as boulders or fallen trees or a wide range of general civil engineering work
B	Normal soil, soft ground	<ul style="list-style-type: none"> These shoes cannot be used on rough ground with large obstacles such as boulders or fallen trees Travel at high speed only on flat ground Travel slowly at low speed if it is impossible to avoid going over obstacles
C	Extremely soft ground (swampy ground)	<ul style="list-style-type: none"> Use the shoes only in the conditions that the machine sinks and it is impossible to use the shoes of category A or B These shoes cannot be used on rough ground with large obstacles such as boulders or fallen trees Travel at high speed only on flat ground Travel slowly at low speed if it is impossible to avoid going over obstacles

8. SPECIFICATIONS FOR MAJOR COMPONENTS

1) ENGINE

Item	Specification
Model	Hyundai HM8.3
Type	4-cycle turbocharged charger air cooled diesel engine
Cooling method	Water cooling
Number of cylinders and arrangement	6 cylinders, in-line
Firing order	1-5-3-6-2-4
Combustion chamber type	Direct injection type
Cylinder bore × stroke	114 × 134.9 mm (4.49" × 5.31")
Piston displacement	8290 cc (506 cu in)
Compression ratio	18 : 1
Rated net horse power (SAE J1349)	245 Hp (183 kW) at 2200 rpm
Rated gross horse power (SAE J1995)	250 Hp (186 kW) at 2200 rpm
Maximum torque	124 kgf · m (899 lbf · ft) at 1300 rpm
Engine oil quantity	26.5 ℓ (7.0 U.S. gal)
Wet weight	617 kg (1360 lb)
High idling speed	2457+ 50 rpm
Low idling speed	850 ± 100 rpm
Rated fuel consumption	151 g/Hp · hr at 1400 rpm
Starting motor	24V-7.2 kW
Alternator	24V 90A
Battery	2 × 12V × 150Ah

2) MAIN PUMP

Item	Specification
Type	Variable displacement tandem axis piston pumps
Capacity	2 × 175 cc/rev
Rated oil flow	2 × 306 ℓ/min (80.8 U.S. gpm / 67.3 U.K. gpm)
Rated speed	1750 rpm

3) GEAR PUMP

Item	Specification
Type	Fixed displacement gear pump single stage
Capacity	15cc/rev
Maximum pressure	40 kgf/cm ² (570 psi)
Rated oil flow	26.3 ℓ /min (6.9 U.S. gpm/5.8 U.K. gpm)

4) MAIN CONTROL VALVE

Item	Specification
Type	10 spools
Operating method	Hydraulic pilot system
Main relief valve pressure	350 kgf/cm ² (4980 psi) [380 kgf/cm ² (5400 psi)]
Overload relief valve pressure	400 kgf/cm ² (5690 psi)

[]: Power boost

5) SWING MOTOR

Item	Specification
Type	Axial piston motor
Capacity	156.9 cc/rev
Relief pressure	300 kgf/cm ² (4270 psi)
Braking system	Automatic, spring applied hydraulic released
Braking torque	84.4 kgf · m (610 lbf · ft)
Brake release pressure	36.5 kgf/cm ² (519 psi)
Reduction gear type	2 - stage planetary

6) TRAVEL MOTOR

Item	Specification
Type	Variable displacement axial piston motor
Relief pressure	350 kgf/cm ² (4980 psi)
Capacity (max / min)	282.6/156.9 cc/rev
Reduction gear type	2-stage planetary
Braking system	Automatic, spring applied hydraulic released
Brake release pressure	17 kgf/cm ² (242 psi)
Braking torque	134 kgf · m (969 lbf · ft)

7) CYLINDER

Item		Specification
Boom cylinder	Bore dia × Rod dia × Stroke	∅ 150 × ∅ 105 × 1480 mm
	Cushion	Extend only
Arm cylinder	Bore dia × Rod dia × Stroke	∅ 160 × ∅ 110 × 1685 mm
	Cushion	Extend and retract
Bucket cylinder	Bore dia × Rod dia × Stroke	∅ 140 × ∅ 100 × 1285 mm
	Cushion	Extend only

※ Discoloration of cylinder rod can occur when the friction reduction additive of lubrication oil spreads on the rod surface.

※ Discoloration does not cause any harmful effect on the cylinder performance.

8) SHOE

Item		Width	Ground pressure	Link quantity	Overall width
HX330S L	Standard	☆ 600 mm (24")	0.64 kgf/cm ² (9.03 psi)	48	3280 mm (10' 9")
	Option	☆ 700 mm (28")	0.55 kgf/cm ² (7.88 psi)	48	3380 mm (11' 1")
		☆ 800 mm (32")	0.49 kgf/cm ² (6.97 psi)	48	3480 mm (11' 5")

☆ : Triple grouser

9. RECOMMENDED OILS

HYUNDAI genuine lubricating oils have been developed to offer the best performance and service life for your equipment. These oils have been tested according to the specifications of HYUNDAI and, therefore, will meet the highest safety and quality requirements.

We recommend that you use only HYUNDAI genuine lubricating oils and grease officially approved by HYUNDAI.

Service point	Kind of fluid	Capacity ℓ (U.S. gal)	Ambient temperature °C (°F)						
			-50 (-58)	-30 (-22)	-20 (-4)	-10 (14)	0 (32)	10 (50)	20 (68)
Engine oil pan	Engine oil★ ¹	26.5 (7.0)	★SAE 0W-40						
			★SAE 0W-30						
			SAE 5W-30						
			SAE 10W-30						
			SAE 15W-40						
Swing drive	Gear oil	11 (2.91)	★SAE 75W-90						
Final drive		7.8×2 (2.1×2)	SAE 80W-90						
Hydraulic tank	Hydraulic oil	Tank : 210 (55.5)	★ISO VG 15						
		System : 414 (109.4)	ISO VG 32						
			ISO VG 46, HBHO VG 46★ ³						
			ISO VG 68						
Fuel tank	Diesel fuel	600 (158.5)	★ASTM D975 NO.1						
			ASTM D975 NO.2						
Fitting (grease nipple)	Grease	As required	★NLGI NO.1						
			NLGI NO.2						
Radiator (reservoir tank)	Mixture of antifreeze and soft water★ ²	27 (7.1)	Ethylene glycol base permanent type (50 : 50)						
			★Ethylene glycol base permanent type (60 : 40)						

SAE : Society of Automotive Engineers

API : American Petroleum Institute

ISO : International Organization for Standardization

NLGI : National Lubricating Grease Institute

ASTM : American Society of Testing and Material

★ : Cold region

Russia, CIS, Mongolia

★¹ : Meet or exceeds API CH-4 grade

★² : Soft water

City water or distilled water

★³ : Hyundai Bio Hydraulic Oil

※ Using any lubricating oils other than HYUNDAI genuine products may lead to a deterioration of performance and cause damage to major components.

※ Do not mix HYUNDAI genuine oil with any other lubricating oil as it may result in damage to the systems of major components.

※ Do not use any engine oil other than that specified above.

※ For HYUNDAI genuine lubricating oils and grease for use in regions with extremely low temperatures, please contact HYUNDAI dealers.