

## SECTION 2 STRUCTURE AND FUNCTION

Group 1 Pump Device .....	2-1
Group 2 Main Control Valve .....	2-20
Group 3 Swing Device .....	2-46
Group 4 Travel Device .....	2-57
Group 5 RCV Lever .....	2-71
Group 6 RCV Pedal .....	2-78

# SECTION 2 STRUCTURE AND FUNCTION

## GROUP 1 PUMP DEVICE

### 1. STRUCTURE

The pump device consists of main pump, regulator and gear pump.

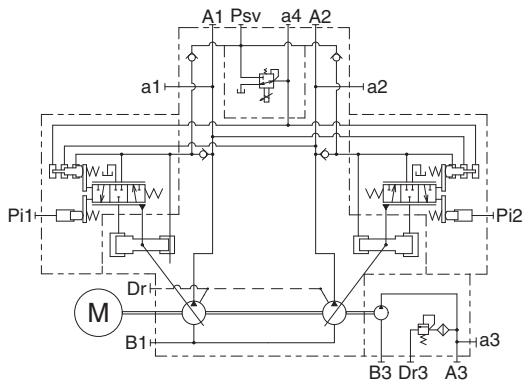
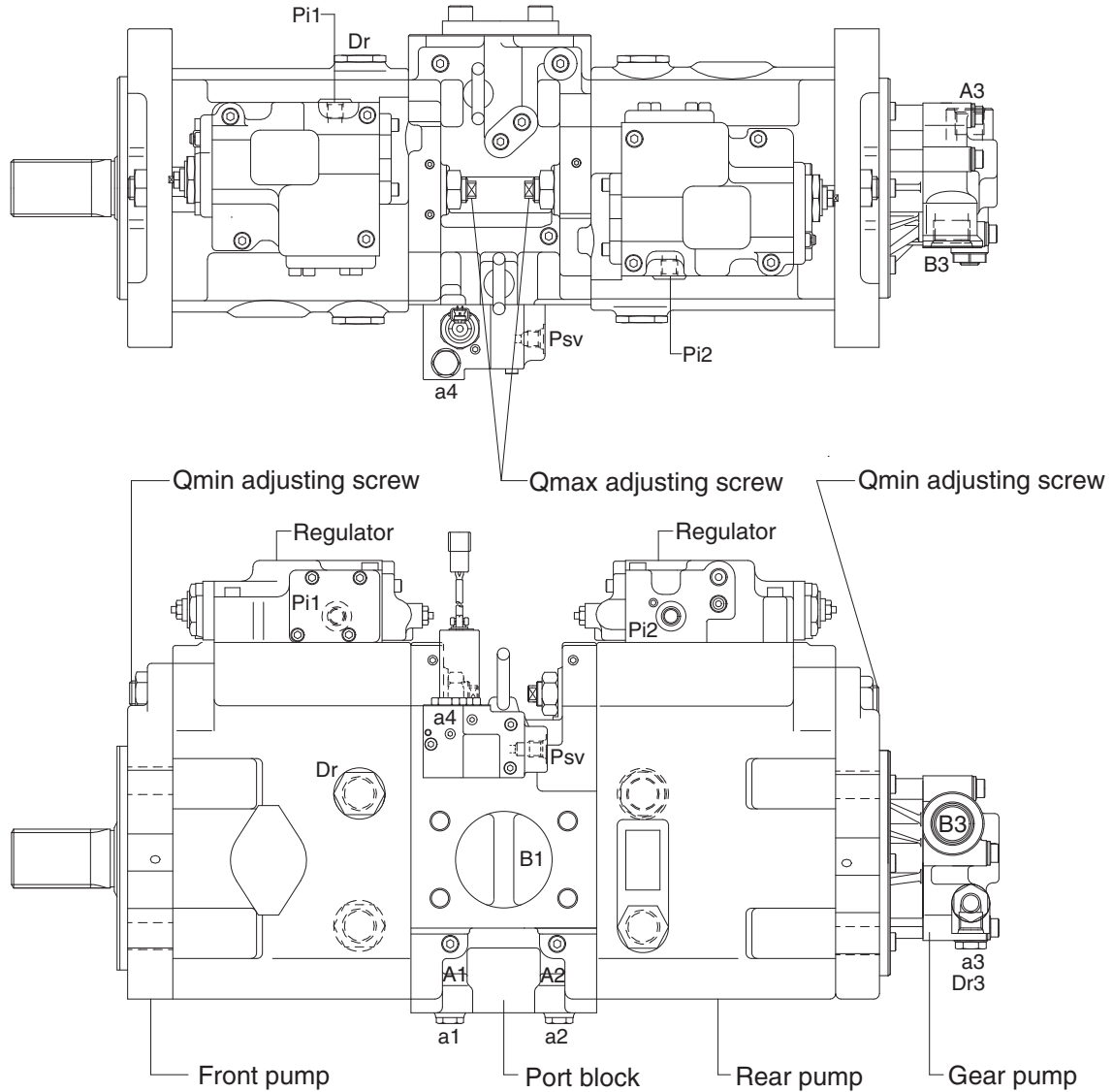

32092MP01

Port	Port name	Port size
A1, 2	Delivery port	SAE6000psi 1"
B1	Suction port	SAE2000psi 3"
Dr	Drain port	PF 3/4 - 23
Pi1, i2	Pilot port	PF 1/4 - 15
Psv	Servo assist port	PF 1/4 - 15
a1, 2, 4	Gauge port	PF 1/4 - 15
a3	Gauge port	PF 1/4 - 14
A3	Gear pump delivery port	PF 1/2 - 19
B3	Gear pump suction port	PF 3/4 - 20.5
Dr3	Gear pump drain port	PF 3/8 - 15

## 1) MAIN PUMP(1/2)

The main pump consists of two piston pumps (front & rear) and valve block.

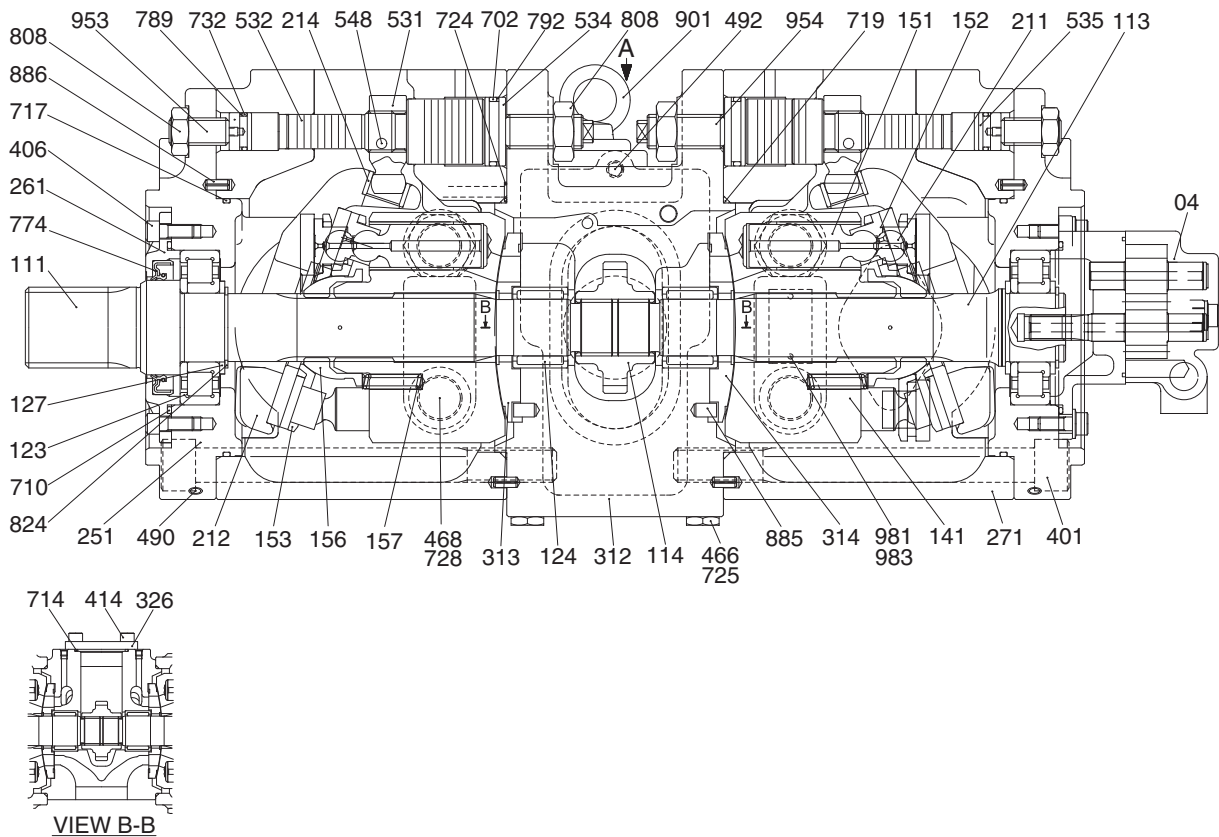

330F2MP01

04	Gear pump	312	Valve block	717	O-ring
111	Drive shaft (F)	313	Valve plate (R)	719	O-ring
113	Drive shaft (R)	314	Valve plate (L)	724	Square ring
114	Gear	326	Cover	725	O-ring
123	Roller bearing	401	Hexagon socket bolt	728	O-ring
124	Needle bearing	406	Hexagon socket bolt	732	O-ring
127	Bearing spacer	414	Hexagon socket bolt	774	Oil seal
141	Cylinder block	466	VP plug	789	Back up ring
151	Piston	468	VP plug	792	Back up ring
152	Shoe	490	VP plug	808	Hexagon head nut
153	Set plate	492	VP plug	824	Snap ring
156	Bushing	531	Tilting pin	885	Pin
157	Cylinder spring	532	Servo piston	886	Spring pin
211	Shoe plate	534	Stopper (L)	901	Eye bolt
212	Swash plate	535	Stopper (S)	953	Set screw
214	Bushing	548	Pin	954	Set screw
251	Swash plate support	702	O-ring	981	Name plate
261	Seal cover (F)	710	O-ring	983	Pin
271	Pump casing	714	O-ring		

MAIN PUMP (2/2)

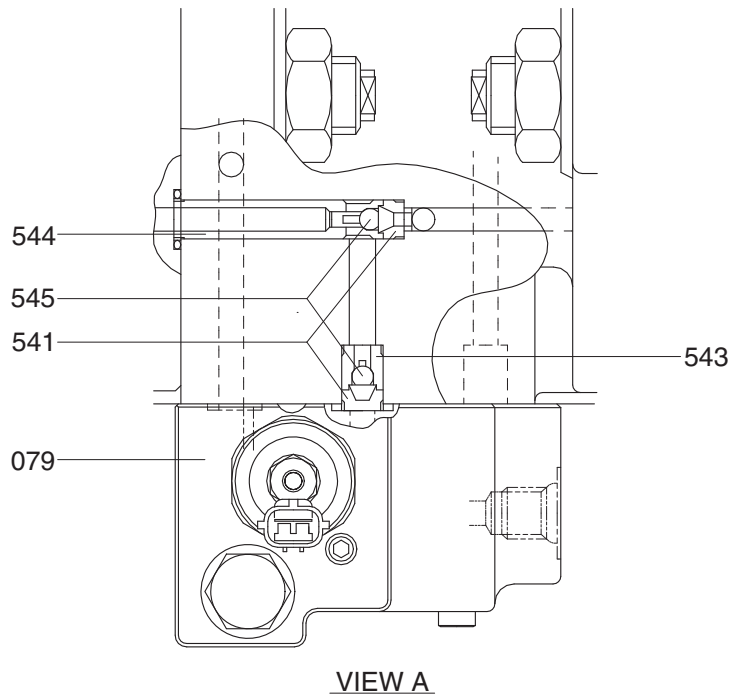

32092MP03

- |     |                             |     |           |     |            |
|-----|-----------------------------|-----|-----------|-----|------------|
| 079 | Proportional reducing valve | 543 | Stopper 1 | 545 | Steel ball |
| 541 | Seat                        | 544 | Stopper 2 |     |            |

## 2) REGULATOR (1/2)

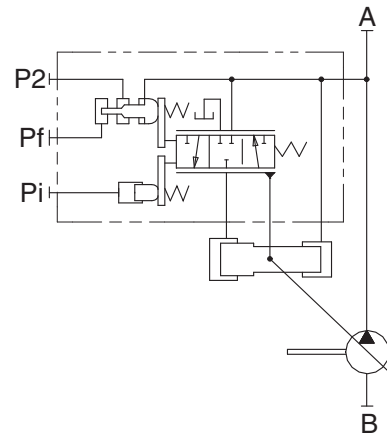
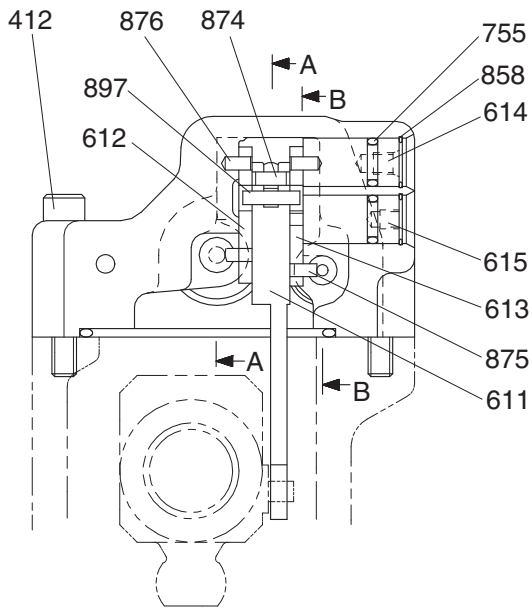

Port	Port name	Port size
A	Delivery port	1"
B	Suction port	3"
Pi	Pilot port	PF 1/4-15
Pf	Power shift pressure	-
P2	Companion delivery pressure	-

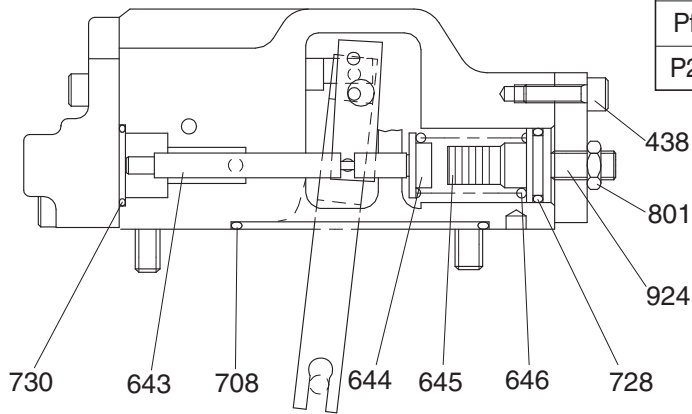

SECTION B-B

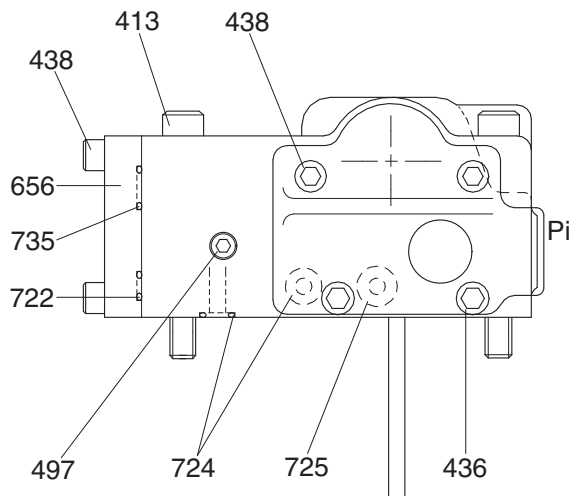

VIEW C

330F2MP02

## REGULATOR (2/2)

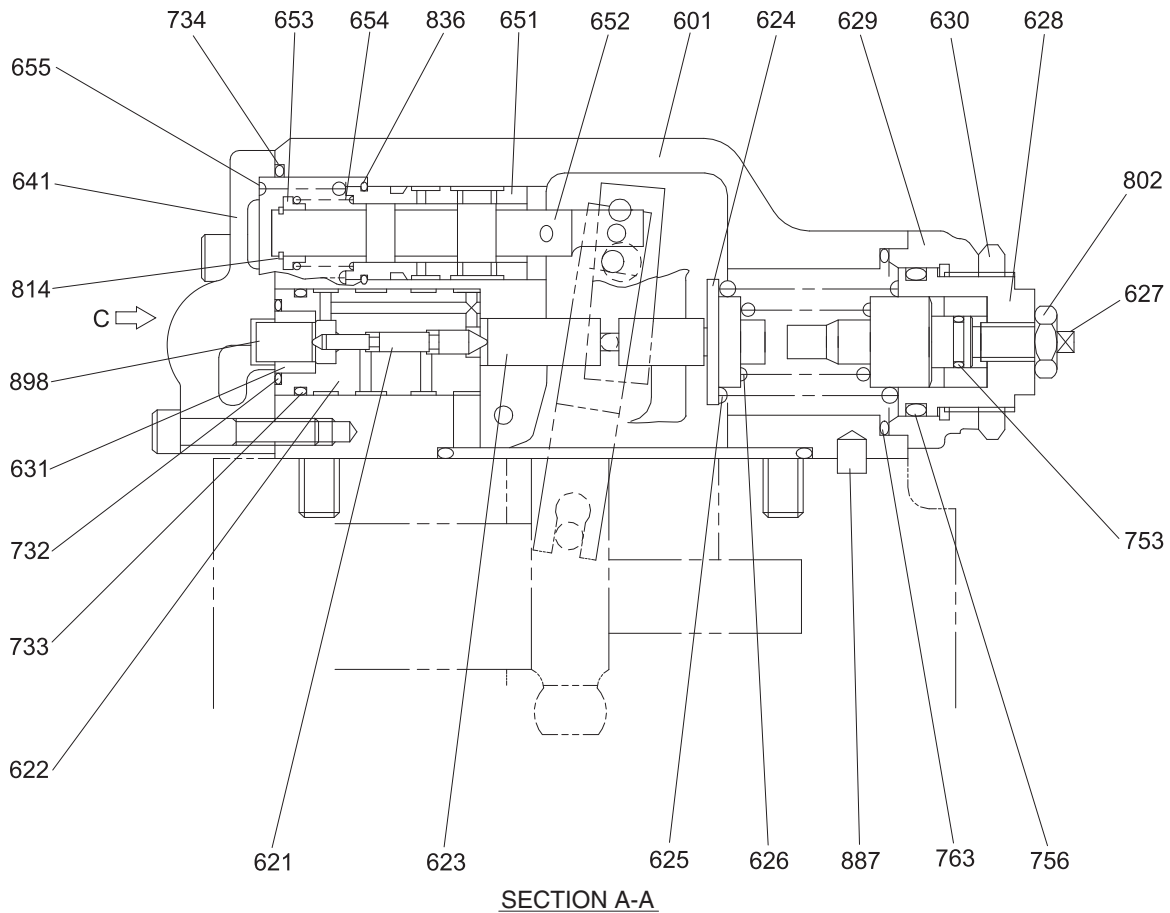

29092MP04A

412 Hexagon socket screw	630 Lock nut	733 O-ring
413 Hexagon socket screw	631 Sleeve, pf	734 O-ring
436 Hexagon socket screw	641 Pilot cover	735 O-ring
438 Hexagon socket screw	643 Pilot piston	753 O-ring
497 Plug	644 Spring seat (Q)	755 O-ring
601 Casing	645 Adjust stem (Q)	756 O-ring
611 Feed back lever	646 Pilot spring	763 O-ring
612 Lever (1)	651 Sleeve	801 Nut
613 Lever (2)	652 Spool	802 Nut
614 Center plug	653 Spring seat	814 Snap ring
615 Adjust plug	654 Return spring	836 Snap ring
621 Compensator piston	655 Set spring	858 Snap ring
622 Piston case	656 Block cover	874 Pin
623 Compensator rod	708 O-ring	875 Pin
624 Spring seat (C)	722 O-ring	876 Pin
625 Outer spring	724 Square ring	887 Pin
626 Inner spring	725 O-ring	897 Pin
627 Adjust stem (C)	728 O-ring	898 Pin
628 Adjust screw (C)	730 O-ring	924 Set screw
629 Cover (C)	732 O-ring	

### 3) GEAR PUMP

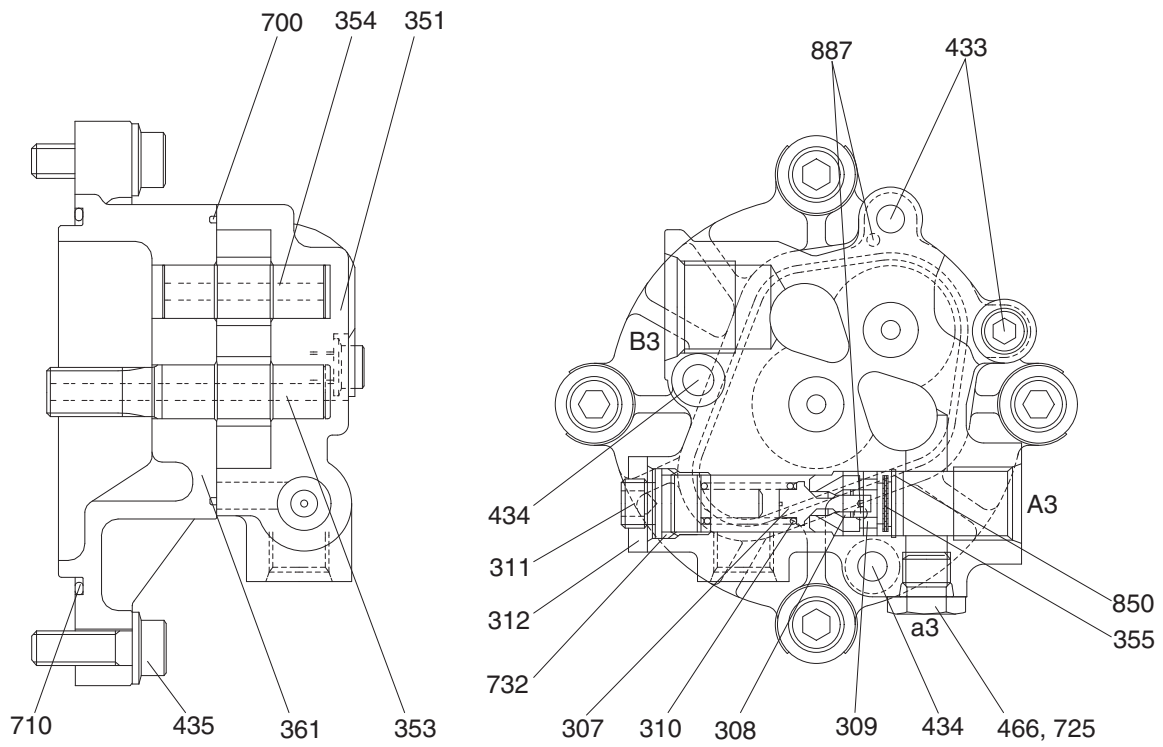

29092MP05

- 307 Poppet
- 308 Seat
- 309 Ring
- 310 Spring
- 311 Screw
- 312 Nut
- 351 Gear case

- 353 Drive gear
- 354 Driven gear
- 355 Filter
- 361 Front case
- 433 Flange socket
- 434 Flange socket
- 435 Flange socket

- 466 Plug
- 700 Ring
- 710 O-ring
- 725 O-ring
- 732 O-ring
- 850 Snap ring
- 887 Pin

## 2. FUNCTION

### 1) MAIN PUMP

The pumps may be classified roughly into the rotary group performing a rotary motion and working as the major part of the whole pump function: the swash plate group that varies the delivery rates: and the valve cover group that changes over oil suction and discharge.

#### (1) Rotary group

The rotary group consists of drive shaft (F)(111), cylinder block (141), piston shoes (151,152), set plate (153), spherical bush (156), and cylinder spring (157). The drive shaft is supported by bearing (123,124) at its both ends.

The shoe is caulked to the piston to form a spherical coupling. It has a pocket to relieve thrust force generated by loading pressure and to take hydraulic balance so that it slides lightly over the shoe plate (211). The sub group composed by a piston and a shoe is pressed against the shoe plate by the action of the cylinder spring via a retainer and a spherical bush. Similarly, the cylinder block is pressed against valve plate (313) by the action of the cylinder spring.

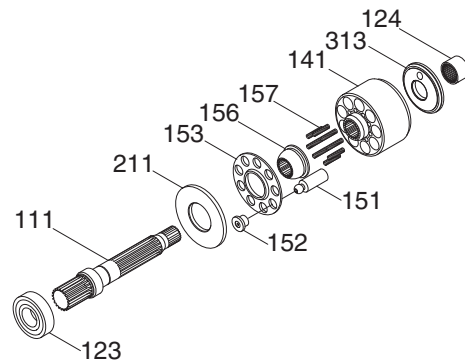

29092MP06

#### (2) Swash plate group

The swash plate group consists of swash plate (212), shoe plate (211), swash plate support (251), tilting bush (214), tilting pin (531) and servo piston (532).

The swash plate is a cylindrical part formed on the opposite side of the sliding surface of the shoe and is supported by the swash support.

If the servo piston moves to the right and left as hydraulic force controlled by the regulator is admitted to hydraulic chamber located on both sides of the servo piston, the swash plate slides over the swash plate support via the spherical part of the tilting pin to change the tilting angle ( $\alpha$ )

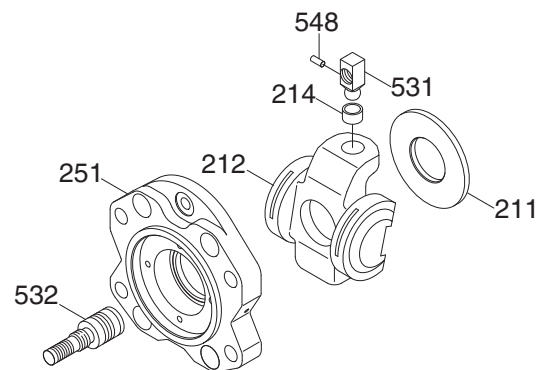

29092MP07

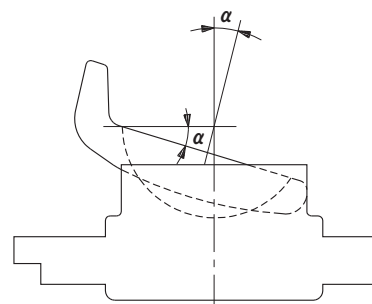

2-7



### (3) Valve block group

The valve block group consists of valve block (312), valve plate (313) and valve plate pin (885).

The valve plate having two melon-shaped ports is fixed to the valve block and feeds and collects oil to and from the cylinder block.

The oil changed over by the valve plate is connected to an external pipeline by way of the valve block.

Now, if the drive shaft is driven by a prime mover (electric motor, engine, etc), it rotates the cylinder block via a spline linkage at the same time. If the swash plate is tilted as in Fig (previous page) the pistons arranged in the cylinder block make a reciprocating motion with respect to the cylinder block, while they revolve with the cylinder block.

If you pay attention to a single piston, it performs a motion away from the valve plate (oil sucking process) within 180 degrees, and makes a motion towards the valve plate (or oil discharging process) in the rest of 180 degrees. When the swash plate has a tilting angle of zero, the piston makes no stroke and discharges no oil.

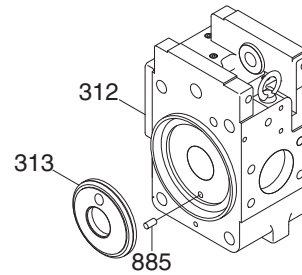

29092MP08

## 2) REGULATOR

Regulator consists of the negative flow control, total horse power control and power shift control function.

### (1) Negative flow control

By changing the pilot pressure  $P_i$ , the pump tilting angle (delivery flow) is regulated arbitrarily, as shown in the figure.

This regulator is of the negative flow control in which the delivery flow  $Q$  decreases as the pilot pressure  $P_i$  rises.

With this mechanism, when the pilot pressure corresponding to the flow required for the work is commanded, the pump discharges the required flow only, and so it does not consume the power uselessly.

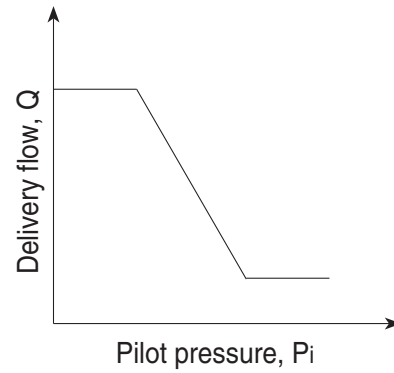

## ① Flow reducing function

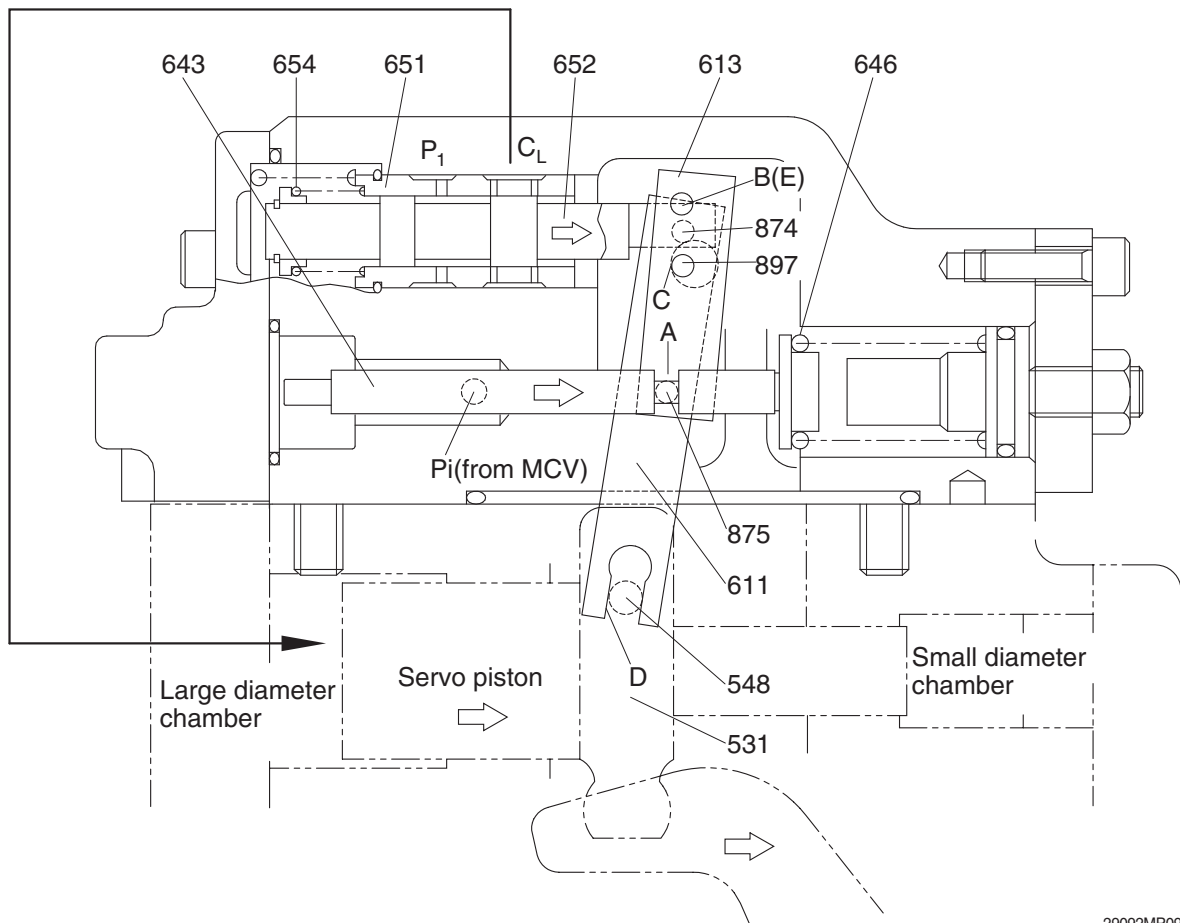

29092MP09A

As the pilot pressure  $P_i$  rises, the pilot piston (643) moves to the right to a position where the force of the pilot spring (646) balances with the hydraulic force.

The groove (A) in the pilot piston is fitted with the pin (875) that is fixed to lever 2 (613). Therefore, when the pilot piston moves, lever 2 rotates around the fulcrum of point B [Fixed by the fulcrum plug (614) and pin (875)]. Since the large hole section (C) of lever 2 contains a protruding pin (897) fixed to the feedback lever (611), the pin (897) moves to the right as lever 2 rotates. Since the opposing-flat section (D) of the feedback lever is fitted with the pin (548) fixed by the tilting pin (531) that swings the swash plate, the feedback lever rotates around the fulcrum of point D, as the pin (897) moves.

Since the feedback lever is connected with the spool (652) via the pin (874), the spool moves to the right.

The movement of the spool causes the delivery pressure  $P_1$  to connect to port CL through the spool and to be admitted to the large diameter section of the servo piston. The delivery pressure  $P_1$  that is constantly admitted to the small diameter section of the servo piston moves the servo piston to the right due to the area difference, resulting in decrease of the tilting angle.

When the servo piston moves to the right, point D also moves to the right. The spool is fitted with the return spring (654) and is tensioned to the left at all times, and so the pin (897) is pressed against the large hole section (C) of lever 2.

Therefore, as point D moves, the feedback lever rotates around the fulcrum of point C, and the spool is shifted to the left. This causes the opening between the sleeve (651) and spool (652) to close slowly, and the servo piston comes to a complete stop when it closes completely.

② Flow increasing function

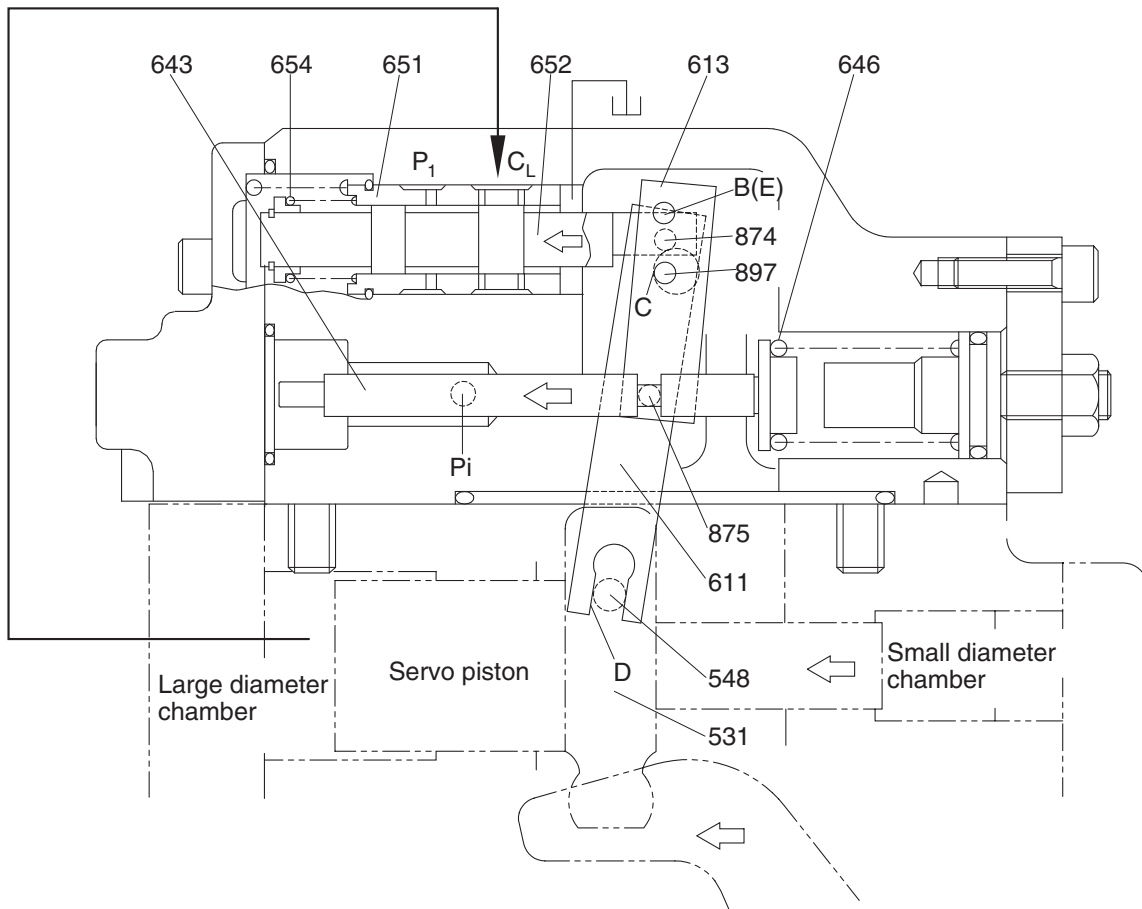

29092MP10

As the pilot pressure  $P_i$  decreases, the pilot piston (643) moves to the left by the action of the pilot spring (646) and causes lever 2 (613) to rotate around the fulcrum of point B. Since the pin (897) is pressed against the large hole section (C) of lever 2 by the action of the return spring (654) via the spool (652), pin (874), and feedback lever (611), the feedback lever rotates around the fulcrum of point D as lever 2 rotates, and shifts the spool to the left. Port CL opens a way to the tank port as the spool moves. This deprives the large diameter section of the servo piston of pressure, and shifts the servo piston to the left by the discharge pressure  $P_1$  in the small diameter section, resulting in an increase in the flow rate.

As the servo piston moves, point D also moves to the left, the feedback lever rotates around the fulcrum of point C, and the spool moves to the right till the opening between the spool and sleeve is closed.

③ **Adjustment of flow control characteristic**

The flow control characteristic can be adjusted with the adjusting screw.

Adjust it by loosening the hexagon nut (801) and by tightening (or loosening) the hexagonal socket head screw (924).

Tightening the screw shifts the control chart to the right as shown in the figure.

※ **Adjusting values are shown in table.**

Speed	Adjustment of flow control characteristic		
	Tightening amount of adjusting screw (924)	Flow control starting pressure change amount	Flow change amount
(min <sup>-1</sup> )	(Turn)	(kgf/cm <sup>2</sup> )	( l /min)
1750	+1/4	+1.0	+18.4

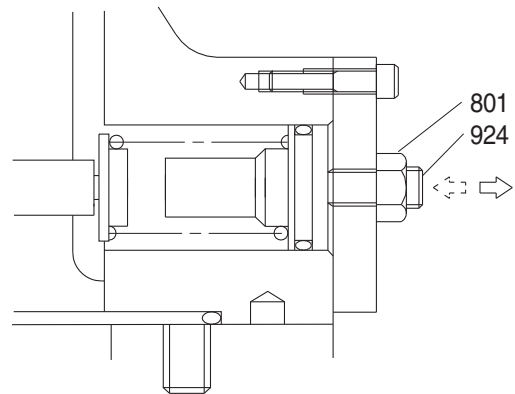

2-12

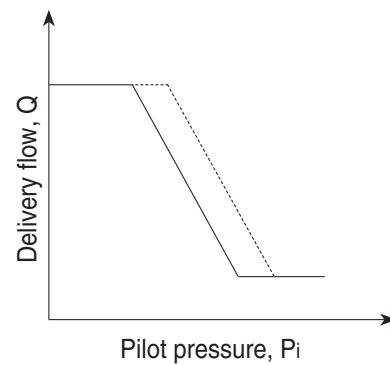

## (2) Total horsepower control

The regulator decreases the pump tilting angle (delivery flow) automatically to limit the input torque within a certain value with a rise in the delivery pressure  $P_1$  of the self pump and the delivery pressure  $P_2$  of the companion pump.

(The input horsepower is constant when the speed is constant.)

Since the regulator is of the simultaneous total horsepower type that operates by the sum of load pressures of the two pumps in the tandem double-pump system, the prime mover is automatically prevented from being overloaded, irrespective of the load condition of the two pumps, when horsepower control is under way.

Since this regulator is of the simultaneous total horsepower type, it controls the tilting angles (displacement volumes) of the two pumps to the same value as represented by the following equation :

$$\begin{aligned} T_{in} &= P_1 \times q / 2 \pi + P_2 \times q / 2 \pi \\ &= (P_1 + P_2) \times q / 2 \pi \end{aligned}$$

The horsepower control function is the same as the flow control function and is summarized in the following. (for detailed behaviors of respective parts, refer to the section of flow control).

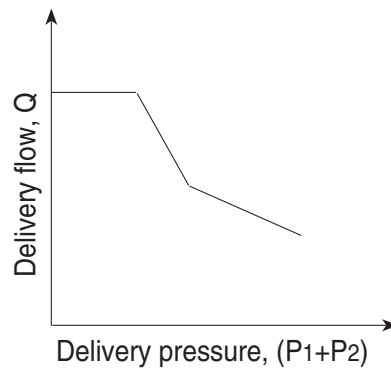

## ① Overload preventive function

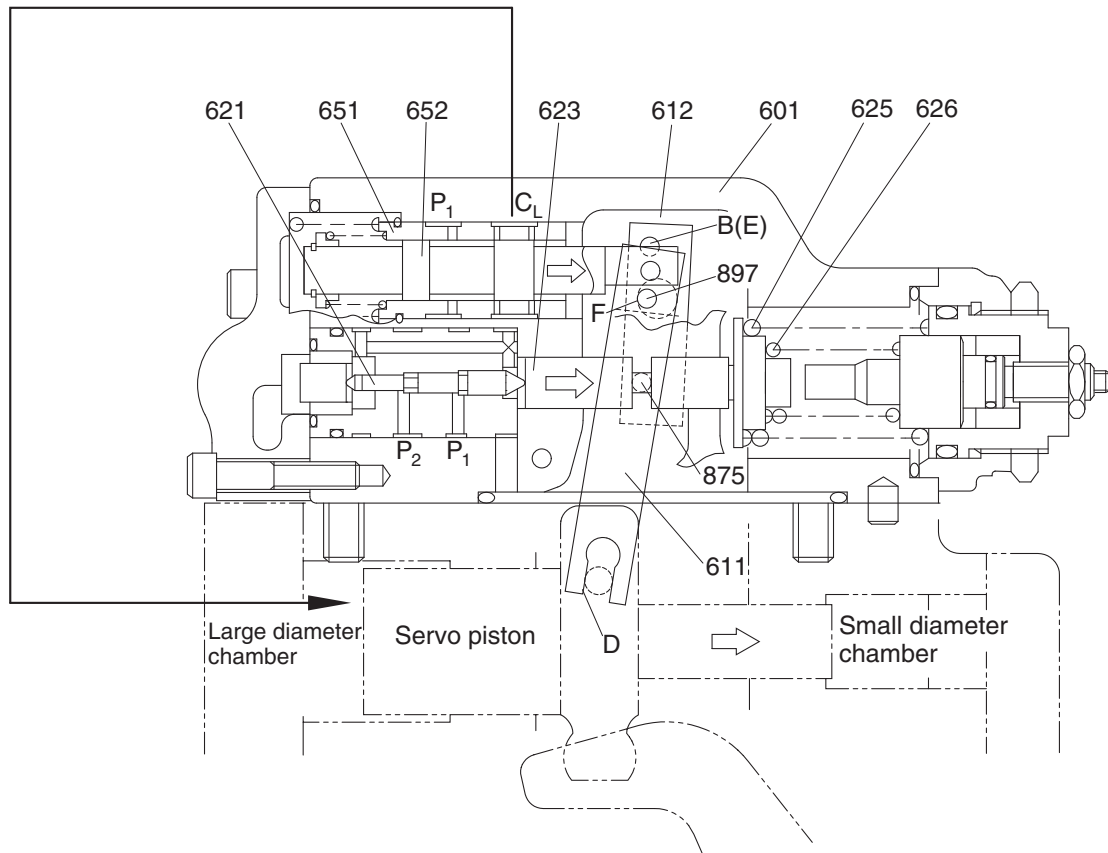

29092MP11

When the self pump delivery pressure  $P_1$  or the companion pump delivery pressure  $P_2$  rises, it acts on the stepped part of the compensating piston (621). It presses the compensating rod (623) to the right till the force of the outer spring (625) and inner spring (626) balances with the hydraulic force. The movement of the compensating rod is transmitted to lever 1 (612) via pin (875).

Lever 1 rotates around the pin (875) (E) fixed to the casing (601).

Since the large hole section (F) of lever 1 contains a protruding pin (897) fixed to the feedback lever (611), the feedback lever rotates around the fulcrum of point D as lever 1 rotates, and then the spool (652) is shifted to the right. As the spool moves, the delivery pressure  $P_1$  is admitted to the large diameter section of the servo piston via port CL, causes the servo piston move to the right, reduces the pump delivery, flow rate, and prevents the prime mover from being overloaded. The movement of the servo piston is transmitted to the feedback lever via point D. Then the feedback lever rotates around the fulcrum of point F and the spool is shifted to the left. The spool moves till the opening between the spool (652) and sleeve (651) is closed.

## ② Flow reset function

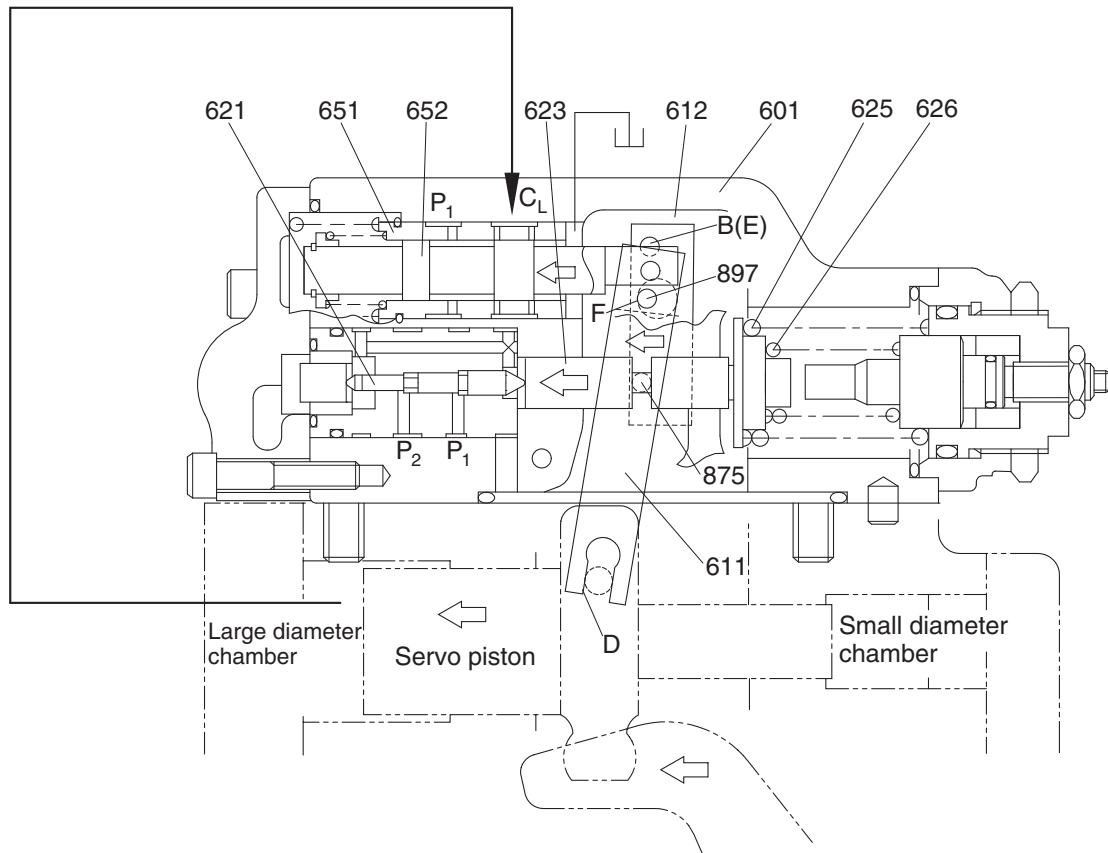

29092MP12

As the self pump delivery pressure  $P_1$  or the companion pump delivery pressure  $P_2$  decreases, the compensating rod (623) is pushed back by the action of the springs (625 & 626) to rotate lever 1 (612) around point E. Rotating of lever 1 (612) causes the feedback lever (611) to rotate around the fulcrum of point D and then the spool (652) to move to the left. As a result, port CL opens a way to the tank port.

This causes the servo piston to move to the left and the pump's delivery rate to increase.

The movement of the servo piston is transmitted to the spool by the action of the feedback mechanism to move it till the opening between the spool and sleeve is closed.



③ **Low tilting angle (low flow) command preferential function**

As mentioned above, flow control and horsepower control tilting angle commands are transmitted to the feedback lever and spool via the large-hole sections (C & F) of levers 1 and 2. However, since sections C and F have the pins ( $\varnothing 4$ ) protruding from the large hole ( $\varnothing 8$ ), only the lever lessening the tilting angle contacts the pin (897); the hole ( $\varnothing 8$ ) in the lever of a larger tilting angle command is freed without contacting the pin (897). Such a mechanical selection method permits preference of the lower tilting angle command of the flow control and horsepower control.

④ **Adjustment of input horsepower**

Since the regulator is of total cumulative horsepower type, adjust the adjusting screws of both the front and rear pumps, when changing the horsepower set values. The pressure change values by adjustment are based on two pumps pressurized at the same time, and the values will be doubled when only one pump is loaded.

a. **Adjustment of outer spring**

Adjust it by loosening the hexagon nut (630) and by tightening (or loosening) the adjusting screw C (628). Tightening the screw shifts the control chart to the right and increases the input horsepower as shown in the figure. Since turning the adjusting screw C by N turns changes the setting of the inner spring (626), return the adjusting screw Q1 (627) by  $N \times A$  turns at first. ( $A=1.9$ )

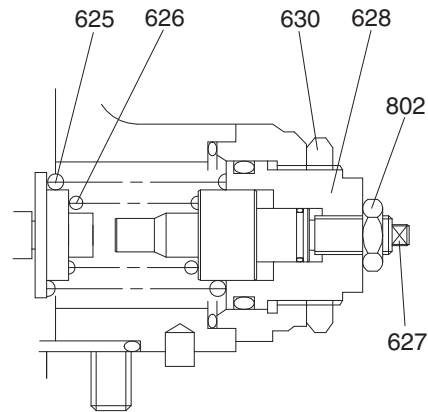

※ **Adjusting values are shown in table.**

8007A2MP03

Speed	Adjustment of outer spring		
	Tightening amount of adjusting screw (C) (628)	Compensating control starting pressure change amount	Input torque change amount
(min <sup>-1</sup> )	(Turn)	(kgf/cm <sup>2</sup> )	(kgf · m)
1750	+1/4	+19.2	+8.5

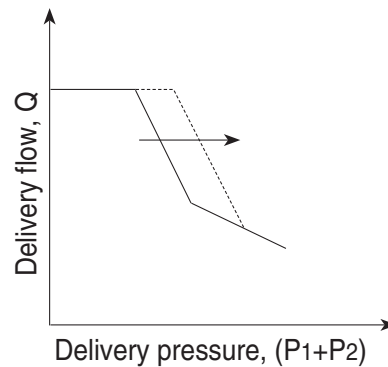

**b. Adjustment of inner spring**

Adjust it by loosening the hexagon nut (802) and by tightening (or loosening) the adjusting screw QI (627).

Tightening the screw increases the flow and then the input horsepower as shown in the figure.

※ Adjusting valves are shown in table.

Speed	Adjustment of inner spring		
	Tightening amount of adjusting screw (QI) (627)	Flow change amount (rpm)	Input torque change amount
(min <sup>-1</sup> )	(Turn)	( l /min)	(kgf · m)
1750	+1/4	+15.9	+8.7

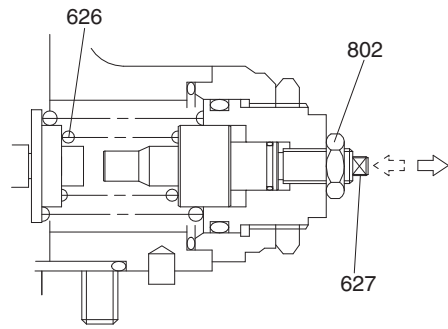

8007A2MP04

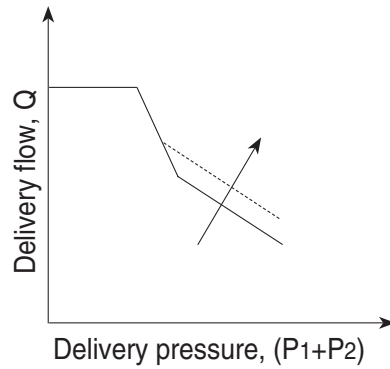

### (3) Power shift control

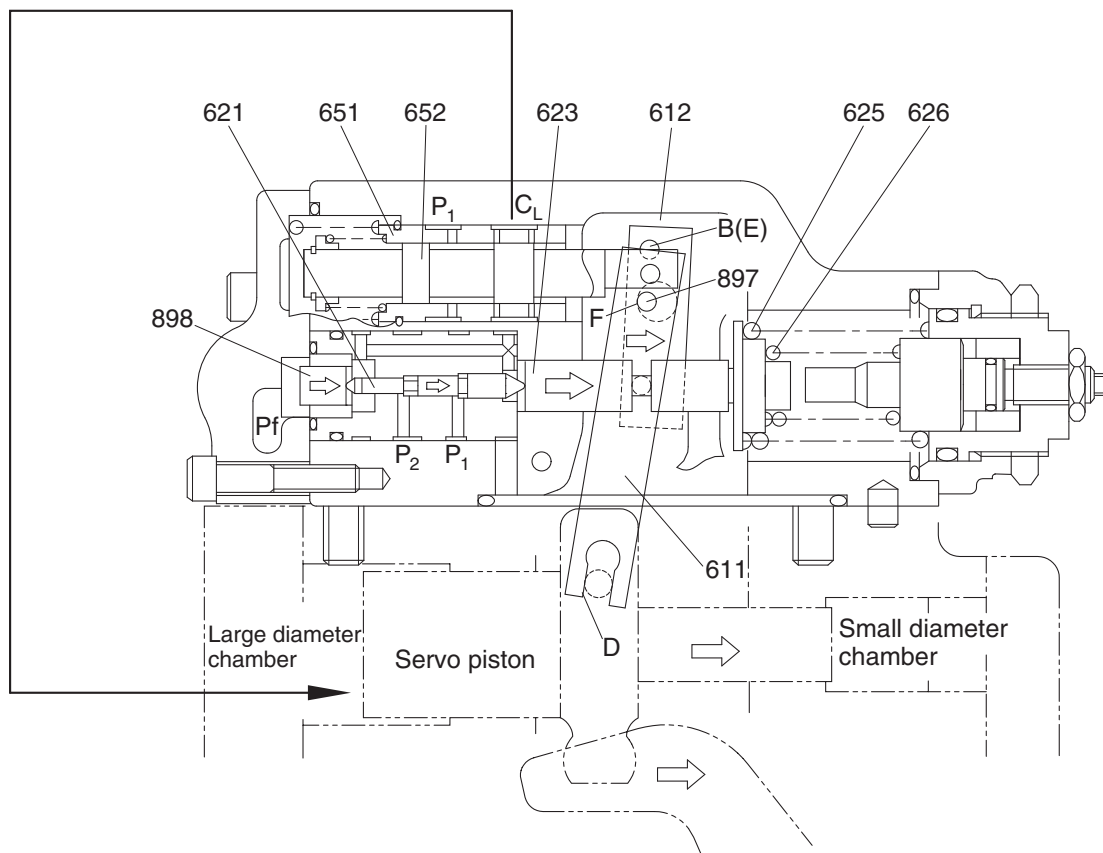

29092MP13

The set horsepower valve is shifted by varying the command current level of the proportional pressure reducing valve attached to the pump. Only one proportional pressure reducing valve is provided.

However, the secondary pressure  $P_f$  (power shift pressure) is admitted to the horsepower control section of each pump regulator through the pump's internal path to shift it to the same set horsepower level.

This function permits arbitrary setting of the pump output power, thereby providing the optimum power level according to the operating condition.

The power shift pressure  $P_f$  controls the set horsepower of the pump to a desired level, as shown in the figure.

As the power shift pressure  $P_f$  rises, the compensating rod (623) moves to the right via the pin (898) and compensating piston (621).

This decreases the pump tilting angle and then the set horsepower in the same way as explained in the overload preventive function of the horsepower control. On the contrary, the set horsepower rises as the power shift pressure  $P_f$  falls.

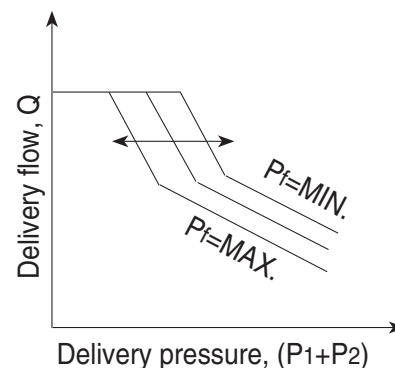

#### (4) Adjustment of maximum and minimum flows

##### ① Adjustment of maximum flow

Adjust it by loosening the hexagon nut (808) and by tightening (or loosening) the set screw (954).

The maximum flow only is adjusted without changing other control characteristics.

Speed	Adjustment of max flow	
	Tightening amount of adjusting screw (954)	Flow change amount
(min <sup>-1</sup> )	(Turn)	( l /min)
1750	+1/4	-6.7

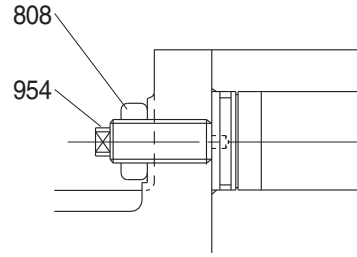

2-19(1)

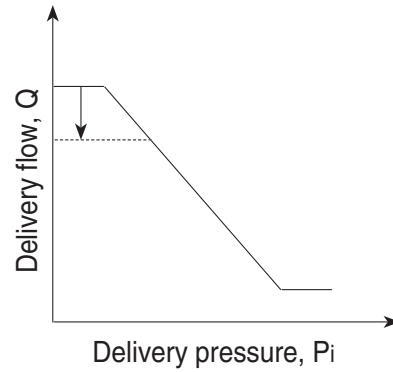

##### ② Adjustment of minimum flow

Adjust it by loosening the hexagon nut (808) and by tightening (or loosening) the hexagonal socket head set screw (953). Similarly to the adjustment of the maximum flow, other characteristics are not changed.

However, remember that, if tightened too much, the required horsepower during the maximum delivery pressure (or during relieving) may increase.

Speed	Adjustment of min flow	
	Tightening amount of adjusting screw (953)	Flow change amount
(min <sup>-1</sup> )	(Turn)	( l /min)
1750	+1/4	+6.7

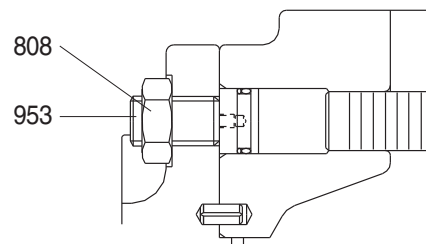

2-19(2)

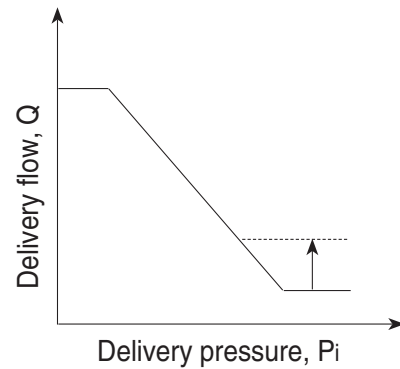

# GROUP 2 MAIN CONTROL VALVE

## 1. STRUCTURE

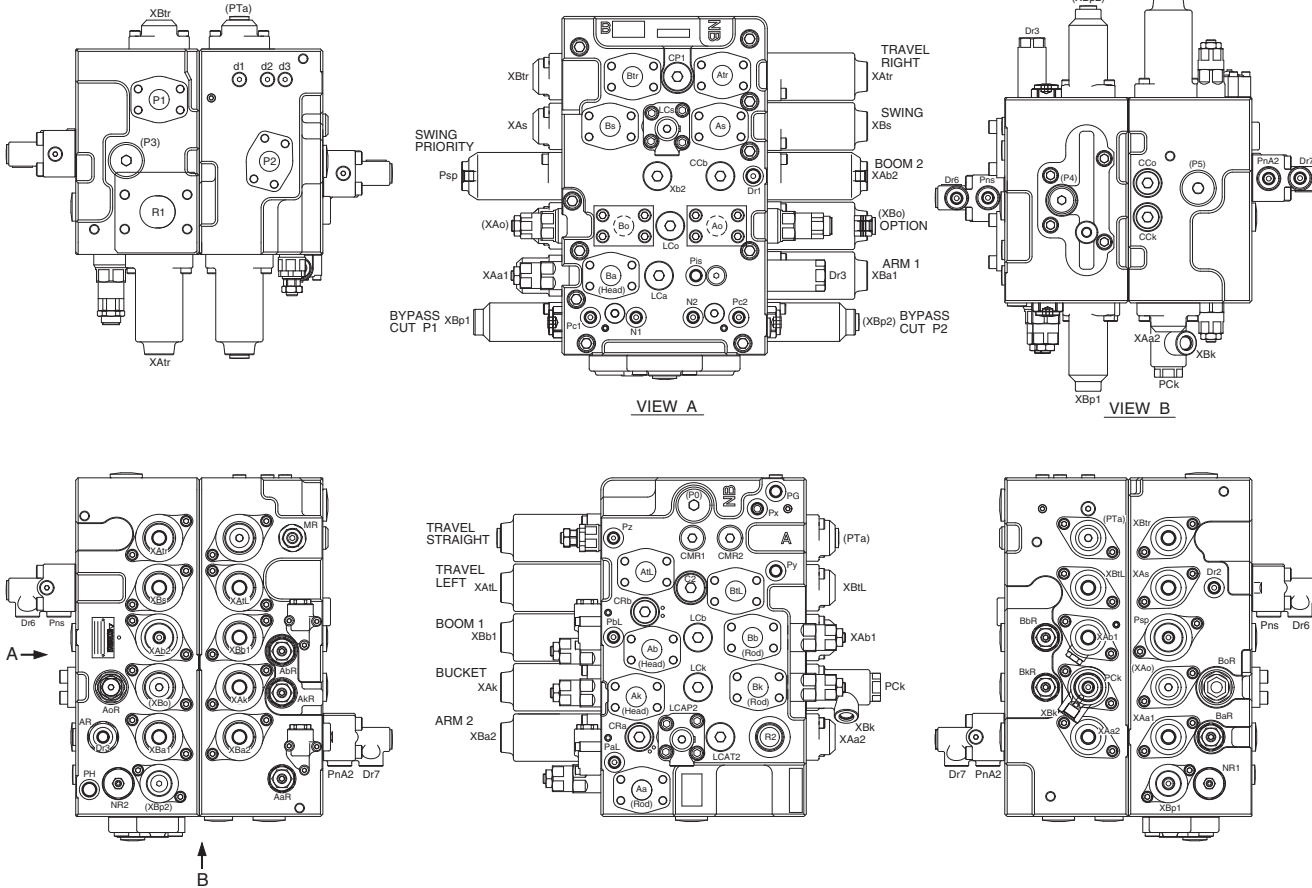

Mark	Port name	Port size	Tightening torque
R2	Make up port for swing	PF 1	20~25 kgf · m (115~180 lbf · ft)
XAtr XBtr (XAo) (XB0) XAk XBk XAb1 XBb1 XAa2 XBa2 XAiL XBIL XAs XBs XAa1 XBa1 (PH) Dr1	Travel right (reverse) pilot port Travel right (forward) pilot port Optional pilot port Optional pilot port Bucket in pilot port Bucket out pilot port Boom up pilot port Boom down pilot port Arm out confluence pilot port Arm in confluence pilot port Travel left (reverse) pilot port Travel left (forward) pilot port Swing left pilot port Swing right pilot port Arm out pilot port Arm in pilot port Pilot pressure port Drain port	PF 3/8	7~8 kgf · m (50.6~57.8 lbf · ft)
Px Py Pz PG Dr2 Dr3 Dr6 Dr7 Pns PaL PbL XAb2 Psp XBp1 (XBp2) (Pc1) (Pc2) Pck Pis N1 N2 PnA2	Pressure port for attachment Pressure port for travel Main relief pilot pressure port Pilot pressure port Drain port Drain port Drain port Drain port Swing logic valve pilot port Lock valve pilot port (arm rod side) Lock valve pilot port (boom head side) Boom up confluence pilot port Swing priority pilot port Bypass cut spool pilot port (P1 side) Bypass cut spool pilot port (P2 side) Posi-nega pressure port (P1 side) Posi-nega pressure port (P2 side) Bucket in stroke limiter pilot port Arm regeneration cut pilot port Arm1 Nega-con pressure port Boom1 Nega-con pressure port Arm2 logic valve pilot port	PF 1/4	3.5~3.9 kgf · m (25.3~28.2 lbf · ft)
Atr Btr (Ao) (Bo) Ak Bk Ab Bb ATL BTL As Bs Aa Ba P1 P2	Travel motor right side (reverse) port Travel motor right side (forward) port Optional port Optional port Bucket cylinder head side port Bucket cylinder rod side port Boom cylinder head side port Boom cylinder rod side port Travel motor left side (reverse) port Travel motor left side (forward) port Swing motor left port Swing motor right port Arm cylinder rod side port Arm cylinder head side port Pump port (P1 side) Pump port (P2 side)	M10	5~6.6 kgf · m (36.1~47.7 lbf · ft)
R1	Return port	M12	8.5~11.2 kgf · m (61.5~81.1 lbf · ft)

330F2MC01

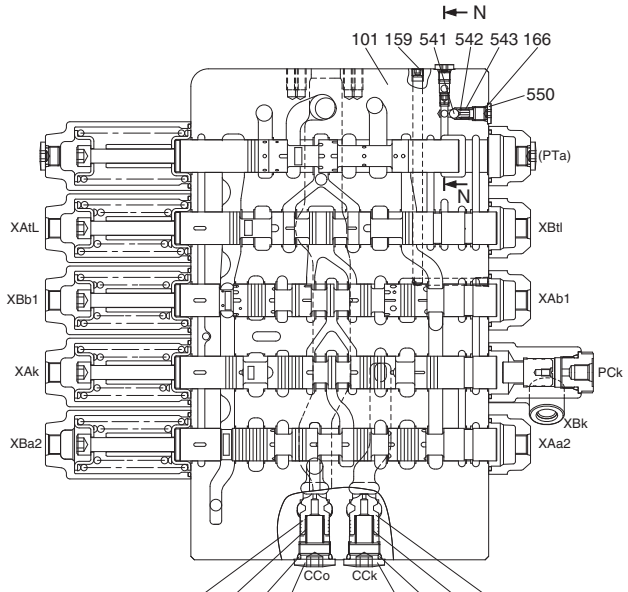

SECTION A-A

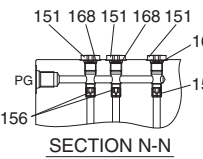
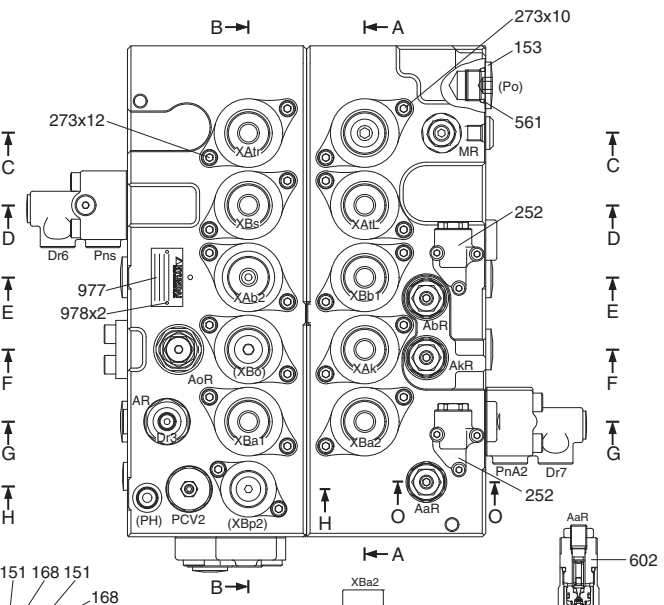

SECTION N-N

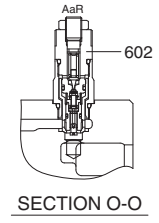

SECTION O-O

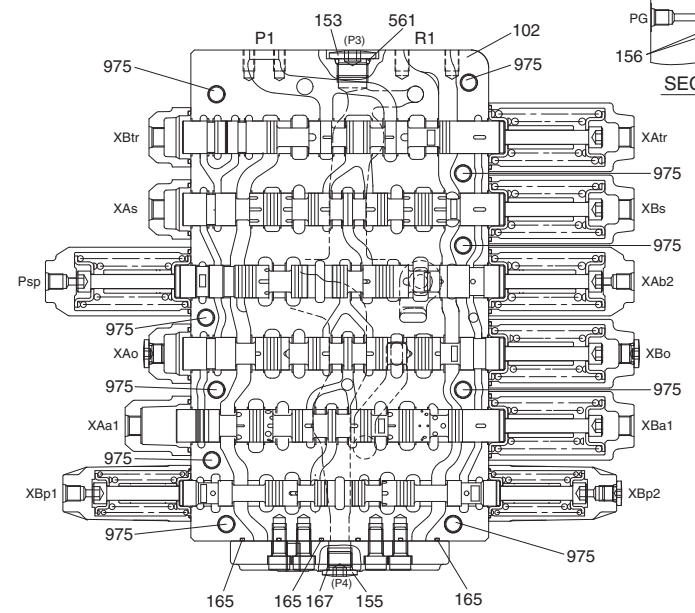

SECTION B-B

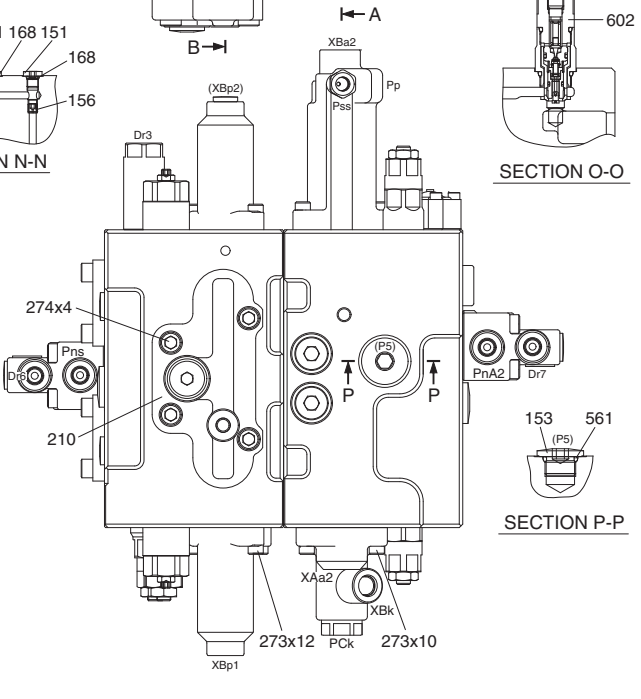

SECTION P-P

- |     |                               |     |                                |
|-----|-------------------------------|-----|--------------------------------|
| 101 | Casing A (P2 housing)         | 308 | Straight travel spool sub assy |
| 102 | Casing B (P1 housing)         | 309 | Spool (option)                 |
| 151 | Plug                          | 310 | Bypass cut spool               |
| 152 | Plug                          | 311 | Swing priority spool           |
| 153 | Plug                          | 313 | Bypass cut spool               |
| 154 | Plug                          | 314 | Travel spool sub assy          |
| 155 | Plug                          | 320 | Spring                         |
| 156 | Orifice                       | 321 | Spring                         |
| 158 | Plug                          | 322 | Spring                         |
| 159 | Plug                          | 323 | Spring                         |
| 161 | O-ring                        | 326 | Spring                         |
| 162 | O-ring                        | 327 | Spring                         |
| 163 | O-ring                        | 329 | Spring                         |
| 164 | O-ring                        | 331 | Spring seat                    |
| 165 | O-ring                        | 332 | Spring seat                    |
| 166 | O-ring                        | 333 | Bolt-spacer                    |
| 167 | O-ring                        | 335 | Stopper                        |
| 168 | O-ring                        | 336 | Bolt-spacer                    |
| 201 | Cover                         | 337 | Stopper                        |
| 202 | Cover                         | 339 | Stopper                        |
| 203 | Cover                         | 370 | Spring                         |
| 204 | Cover                         | 371 | Spring                         |
| 205 | Cover                         | 372 | Spring                         |
| 206 | Cover                         | 373 | Spring                         |
| 208 | Cover                         | 511 | Poppet                         |
| 209 | Flange                        | 512 | Poppet                         |
| 210 | Plate                         | 513 | Poppet                         |
| 211 | Piston                        | 514 | Poppet                         |
| 250 | Logic control valve assy      | 521 | Spring                         |
| 251 | Logic control valve assy      | 522 | Spring                         |
| 252 | Lock valve selector sub assy  | 523 | Spring                         |
| 254 | Logic poppet assy             | 541 | Steel ball                     |
| 256 | Logic poppet assy             | 542 | Spring seat                    |
| 257 | Arm regeneration cut sub assy | 543 | Spring                         |
| 258 | Plug                          | 550 | Plug                           |
| 259 | Plug                          | 551 | Plug                           |
| 260 | Plug                          | 552 | Plug                           |
| 261 | O-ring                        | 553 | Plug                           |
| 262 | O-ring                        | 561 | O-ring                         |
| 264 | O-ring                        | 562 | O-ring                         |
| 273 | Socket bolt                   | 601 | Main relief valve assy         |
| 274 | Socket bolt                   | 602 | Port relief valve assy         |
| 301 | Travel spool                  | 603 | Port relief valve assy         |
| 302 | Arm 1 spool sub assy          | 610 | Nega-con relief valve          |
| 303 | Boom 1 spool sub assy         | 971 | Bolt                           |
| 304 | Bucket spool                  | 975 | Bolt                           |
| 305 | Swing spool                   | 977 | Name plate                     |
| 306 | Arm 2 spool                   | 978 | Pin                            |
| 307 | Boom 2 spool                  |     |                                |

330F2MC02

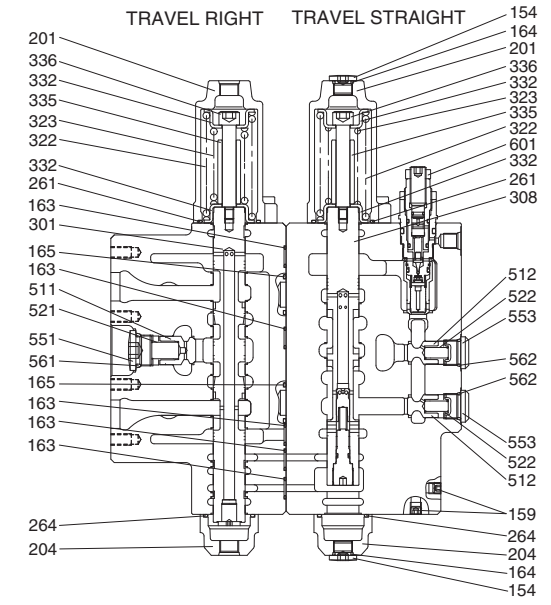

SECTION C-C

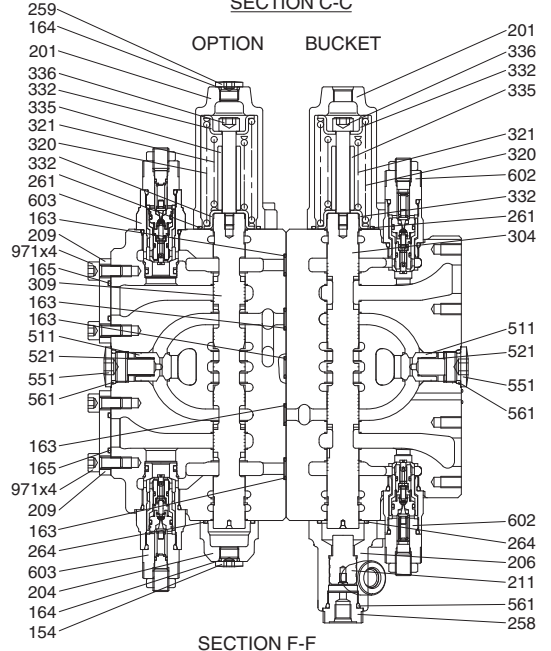

SECTION F-F

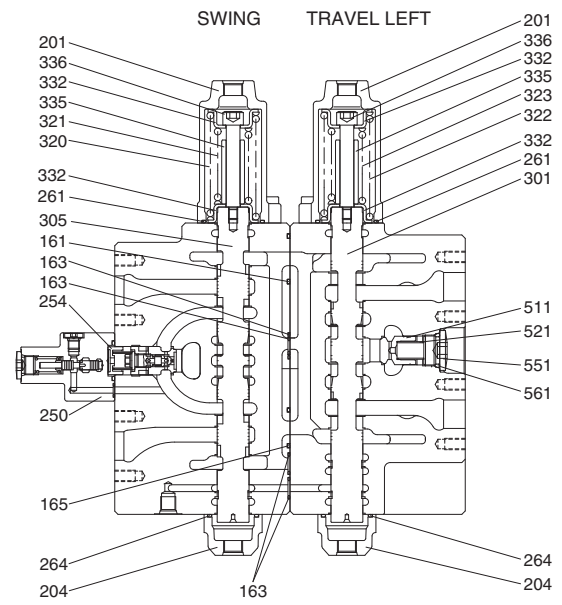

SECTION D-D

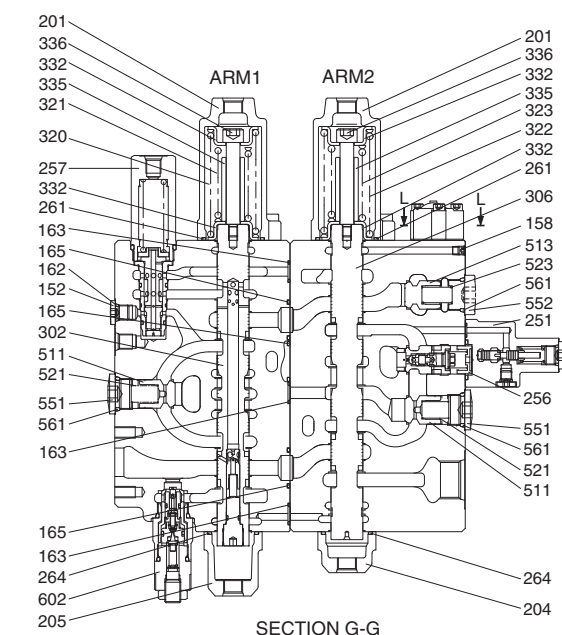

SECTION G-G

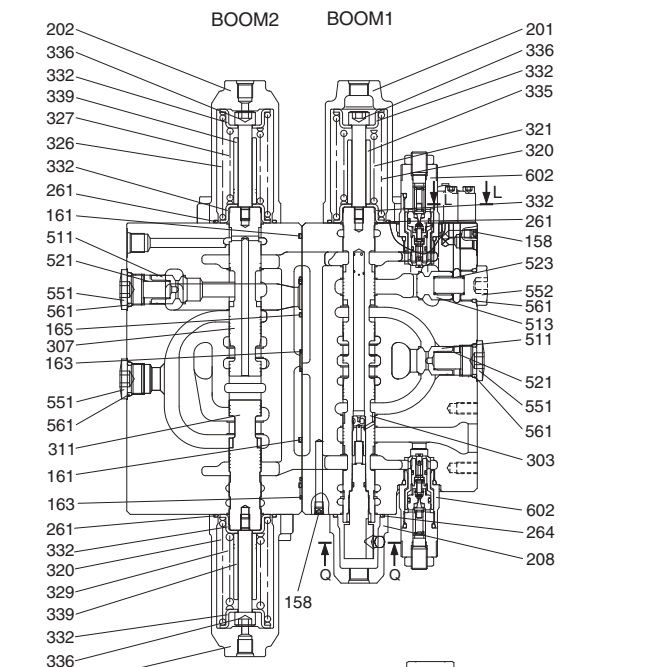

SECTION E-E

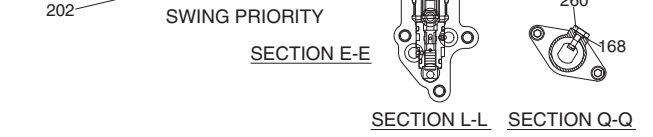

SECTION L-L SECTION Q-Q

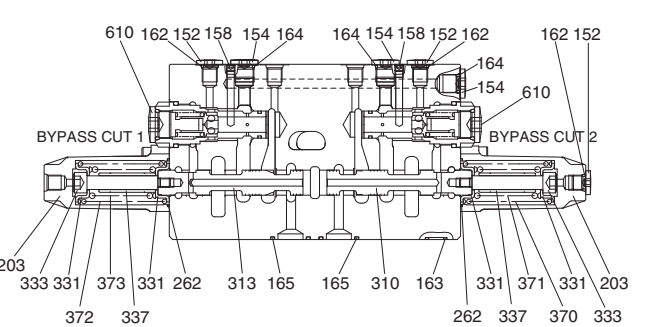

SECTION H-H

## 2. HYDRAULIC CIRCUIT

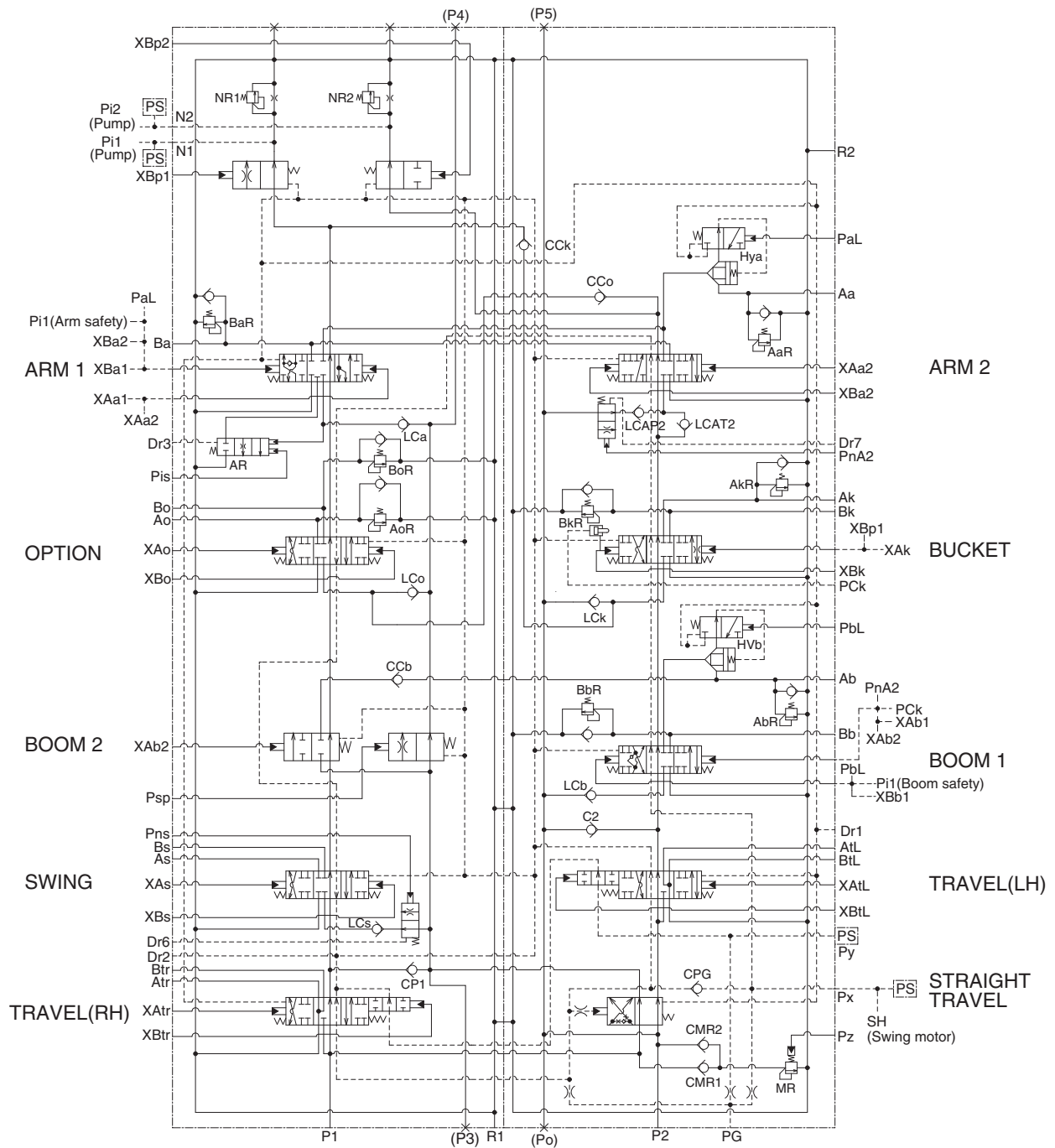

330F2MC04



### 3. FUNCTION

#### 1) CONTROL IN NEUTRAL POSITION

##### **Main circuit**

When all spools are in the neutral positions, the pressurized oil discharged from the hydraulic pump (A1) passes through Port P1, the main path (1), the bypass circuit (2) passing the spools for travel right (314), swing (305), boom confluence (boom 2; 307), option (309) and arm 1 (302), and the arm 1 side negative control relief valve (610), and returns to the hydraulic oil tank through the tank port (R1).

The negative control signal pressure of the arm 1 side negative control relief valve (610) is led from Port N1 to the regulator on the hydraulic pump (A1) side, and controls the pump discharge flow rate to its minimum value.

The oil discharged from the hydraulic pump (A2) passes through Port P2, the main path (3), the bypass circuit (2) passing the spools for travel left (301), boom 1 (303), bucket (304) and arm 2 (306), and the boom1 side negative control relief valve (610), and returns to the hydraulic oil tank through the tank port (R1).

The negative control signal pressure of the boom 1 side negative control relief valve (610) is led from Port N2 to the regulator on the hydraulic pump (A2) side, and controls the pump discharge flow rate to its minimum value.

When any of nine main spools is changed over, the bypass circuit (2) is cut off and the hydraulic oil at Port N1 or N2 in the negative control circuit is shut off.

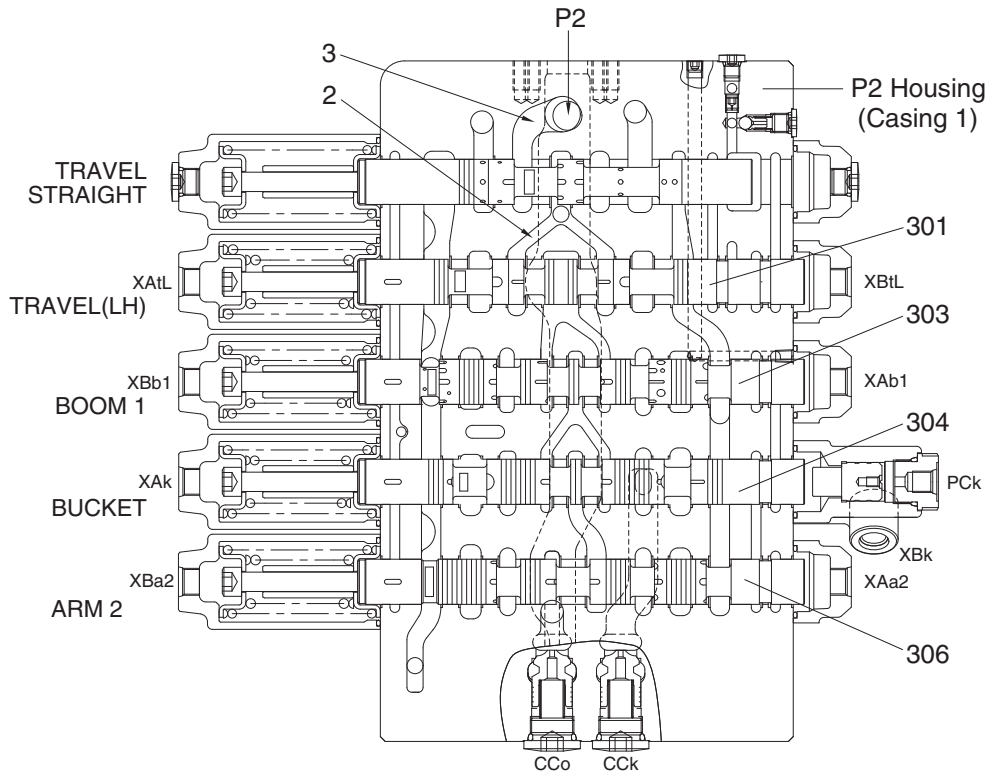

SPOOL SECTION(P2)

32092MC05

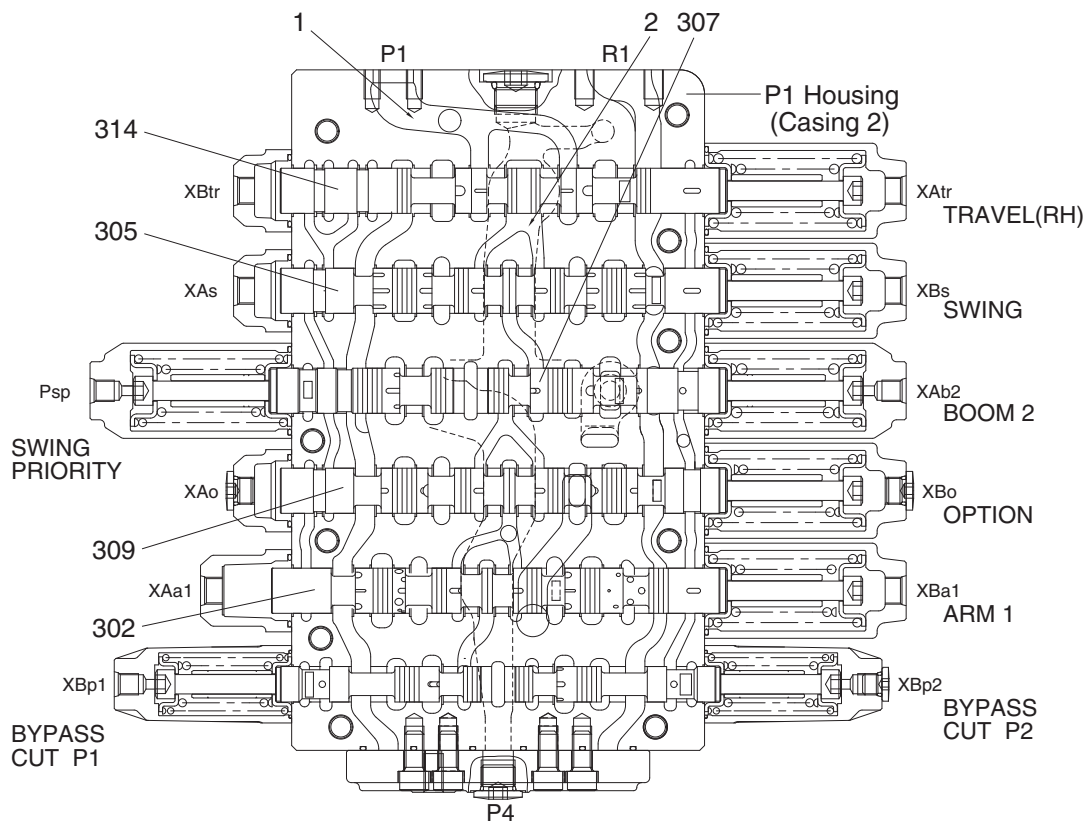

SPOOL SECTION(P1)

330F2MC05

## 2) EACH SPOOL OPERATION

### (1) Travel control

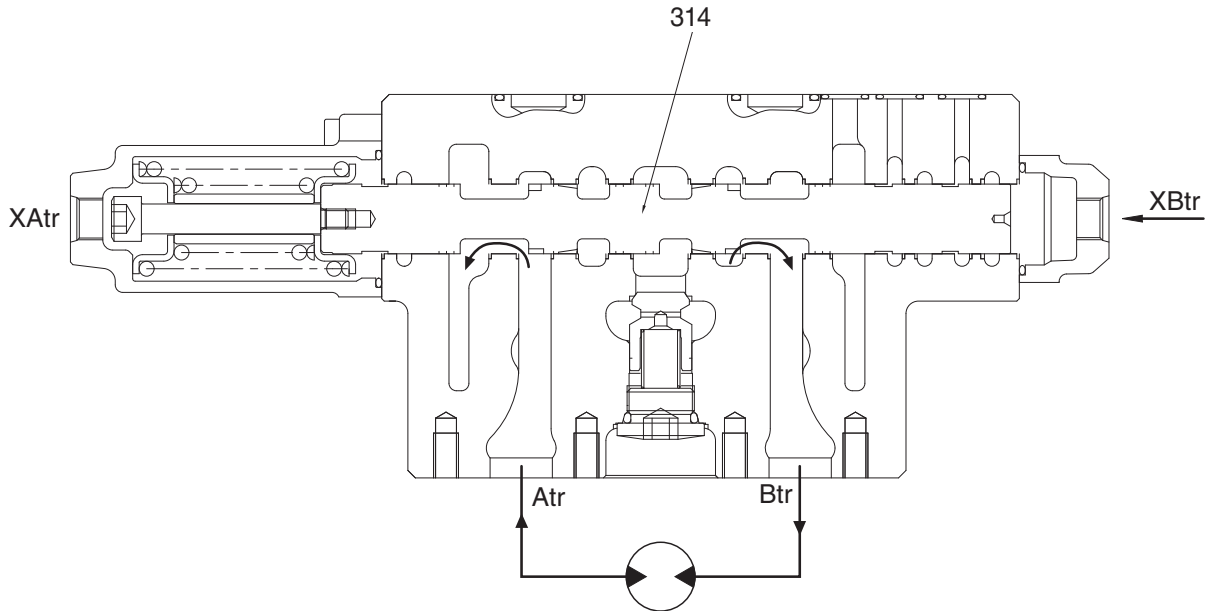

21092MC21

#### **Pilot circuit**

Since any of the travel spools (314, 301) on the left or right transfers and shuts off the side-bypass path, the pressure at Port Py increases.

#### **Main circuit**

When Pilot Port XBtr of the travel right spool (314) is pressurized, the bypass circuit (2) in the arm 1 side is shut off and the working fluid discharged from the hydraulic pump (A1) through Port Btr and flows to the travel right motor.

When Pilot Port XBtL of the travel left spool (301) is pressurized, the bypass circuit (2) in the boom 1 side is shut off and the working fluid discharged from the hydraulic pump (A2), similarly to that from the hydraulic pump (A1), through Port BtL and flows to the travel left motor.

On the other hand, the return oil from the right and left travel motor passes flows from Port Atr (AtL) to the travel right (left) spools (314, 301) and returns to the hydraulic oil tank through the tank port (R1).

In the case of the opposite operation (when the pilot pressure is applied to Ports XAtr and XAtL of the control valve), the operation is similar.

## (2) Arm control

### ① Arm out operation

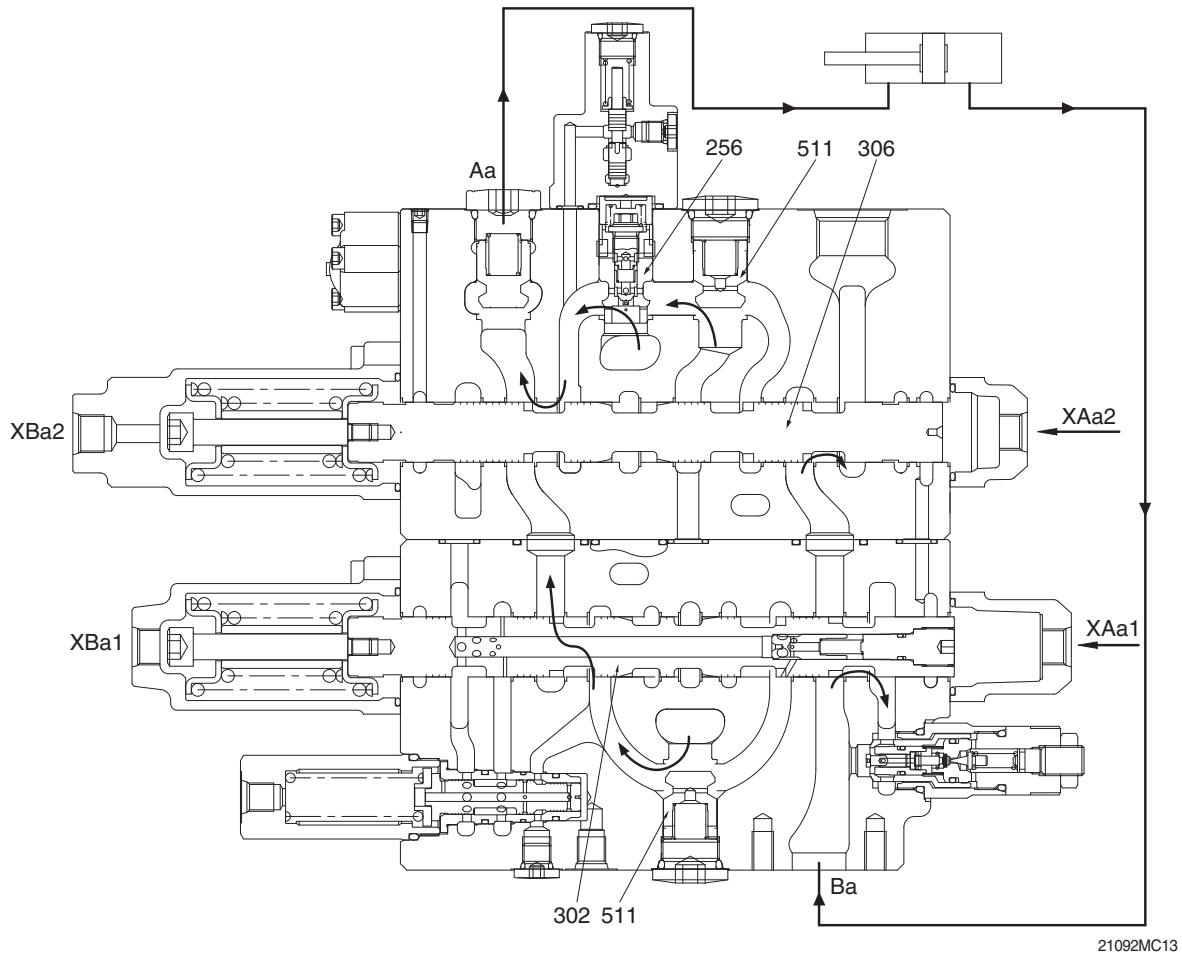

#### Pilot circuit

Since the arm 2 spool (306) transfers and shuts off the side-bypass path, the pressure at Port Px increases.

#### Main circuit

During the arm out operation, the pilot pressure enters through Ports XAa1 and XAa2. When the pressure enters through Port XAa1 and XAa2, the spools transfer in the left direction. The hydraulic oil entering through Port P1 passes through the main path (1) and flows to the bypass circuit (2), but the bypass circuit is shut off due to transfer of the arm 1 spool (302).

Therefore, the hydraulic oil from the parallel circuit pushes open the check valve (511) and flows through the U-shaped path to the arm 1 spool (302). Then, it flows around the periphery of the arm 1 spool (302) and the arm 2 spool (306) to Port Aa, and is supplied to the arm cylinder rod side.

On the other hand, the hydraulic oil entering through Port P2 passes in the main path (3), and flows into the bypass circuit (2), and the bypass circuit is shut off due to transfer of the arm 2 spool (306). The hydraulic oil from the parallel circuit pushes open the logic poppet (256) and the hydraulic oil from the bypass circuit (2) pushes open the check valve (511) and flows through the U-shaped path to the arm 2 spool (306). Then, it flows around the periphery of the arm 2 spool (306) in the inside path and joins into Port Aa.

Besides, the return oil from the arm cylinder head side passes through Port Ba, flows into tank line in arm 1 side and in arm 2 side, and returns to the hydraulic oil tank through the tank port (R1).

- ② Arm in operation
  - During light load only

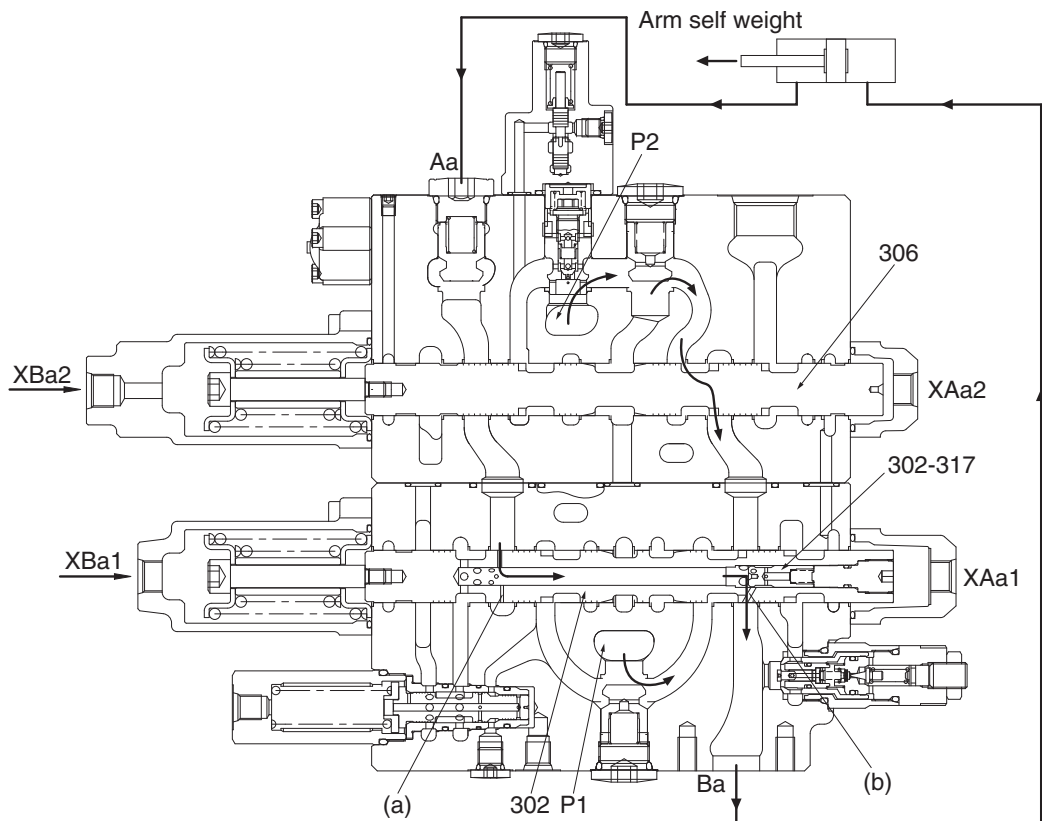

21092MC14

### Pilot circuit

Since the arm 2 spool (306) transfers and shuts off the side-bypass path, the pressure at Port Px increases. Then, the pressure enters also through Port PaL and the release signal is sent to the lock valve (252).

### Main circuit

During the arm in operation, the pilot pressure enters through Ports XBa1 and XBa2. When the pressure enters through Port XBa1 and Port XBa2, the spools transfer in the right direction Fig. MC14. The hydraulic oil entering through Port P1 passes through the main path (1) and flows to the bypass circuit (2), but the bypass circuit is shut off due to transfer of the arm 1 spool (302). Therefore, the hydraulic oil from the parallel circuit pushes open the check valve (511) and flows through the U-shaped path to the arm 1 spool (302). Then, it flows around the periphery of the arm 1 spool (302) to Port Ba, and is supplied to the arm cylinder head side.

On the other hand, the hydraulic oil entering through Port P2 passes in the main path (3), and flows into the bypass circuit (2), and the bypass circuit is shut off due to transfer of the arm 2 spool (306). The hydraulic oil from the parallel circuit pushes open the logic poppet (256) and the hydraulic oil from the bypass circuit (2) pushes open the check valve (511) and flows through the U-shaped path to the arm 2 spool (306). Then, it flows around the periphery of the arm 2 spool (306) and the arm 1 spool (302) in the inside path and joins into Port Ba.

Besides, the return oil from the arm cylinder rod side is pressurized by self-weight of the arms and so on, and returns to Port Aa. The pressurized oil returning to Port Aa enters into the spool through the periphery hole (a) of the arm 1 spool (302). During a light load only, it pushes open the check valve (302-317) and joins into Port Ba from the spool hole (b). The rest of oil returns to the hydraulic oil tank through the tank port (R1). This is called the arm regeneration function.

- The pressure in the arm cylinder head side increases

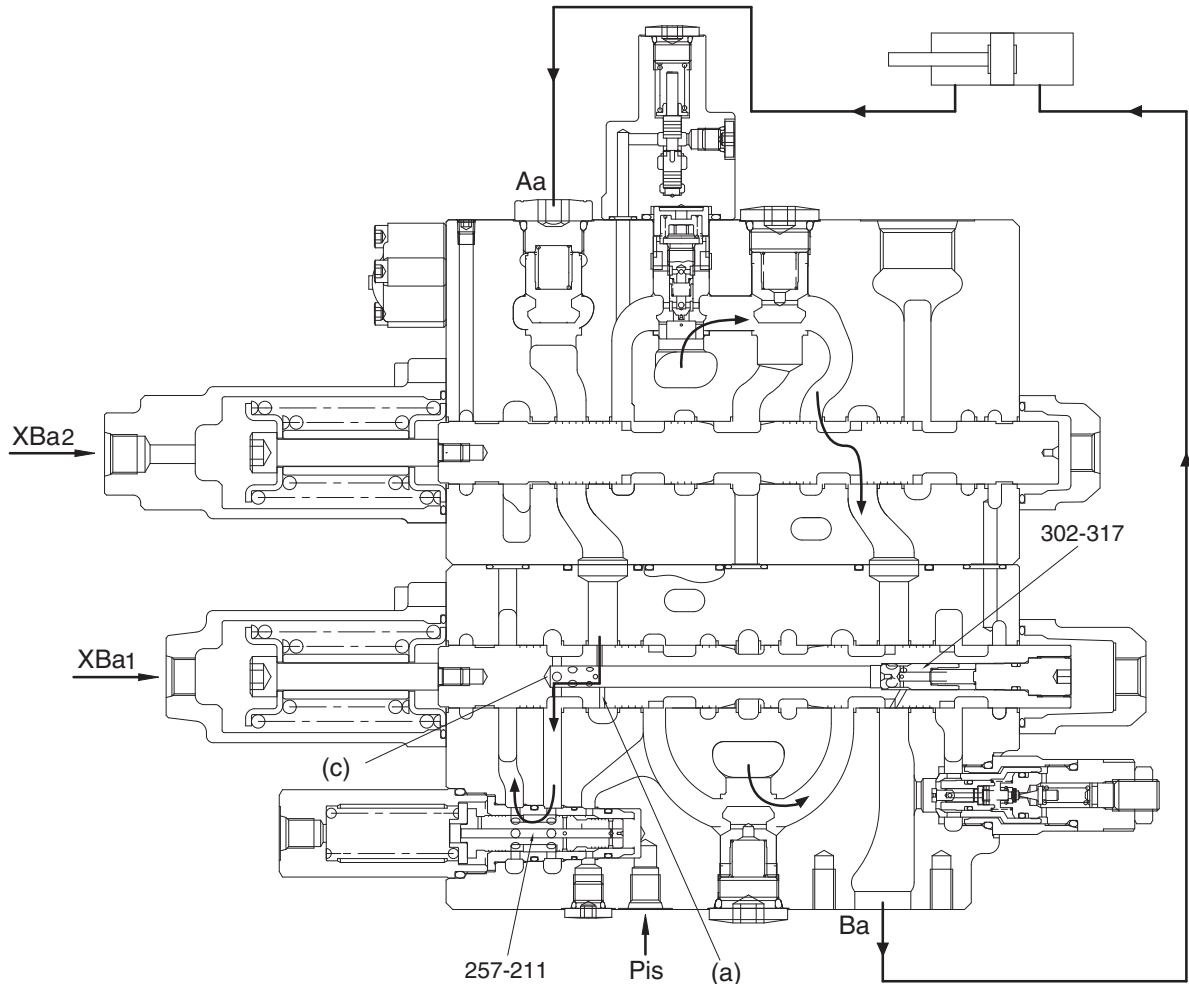

21092MC15

When the pressure in the arm cylinder head side and the U-shaped path increases, the arm regeneration cut spool (257-211) is transferred in the left direction, and at the same time the check valve (302-317) is closed by its backpressure. This shuts off the arm regeneration function, and the return oil from the arm cylinder rod side enters from Port Aa through the periphery hole (a) of the arm 1 spool (302) into the spool, flows to the arm regeneration cut valve (257) through the periphery hole (c) of the arm 1 spool (302), and returns through the tank port (R1) to the hydraulic oil tank.

When the Pilot Port Pis of the arm regeneration cut spool (257-211) is pressurized, a part of the return oil from the arm cylinder rod side flows to the arm regeneration cut valve (257) and returns through the tank port (R1) to the hydraulic oil tank. (Variable arm regeneration)

### ③ Arm 2 logic control valve operation

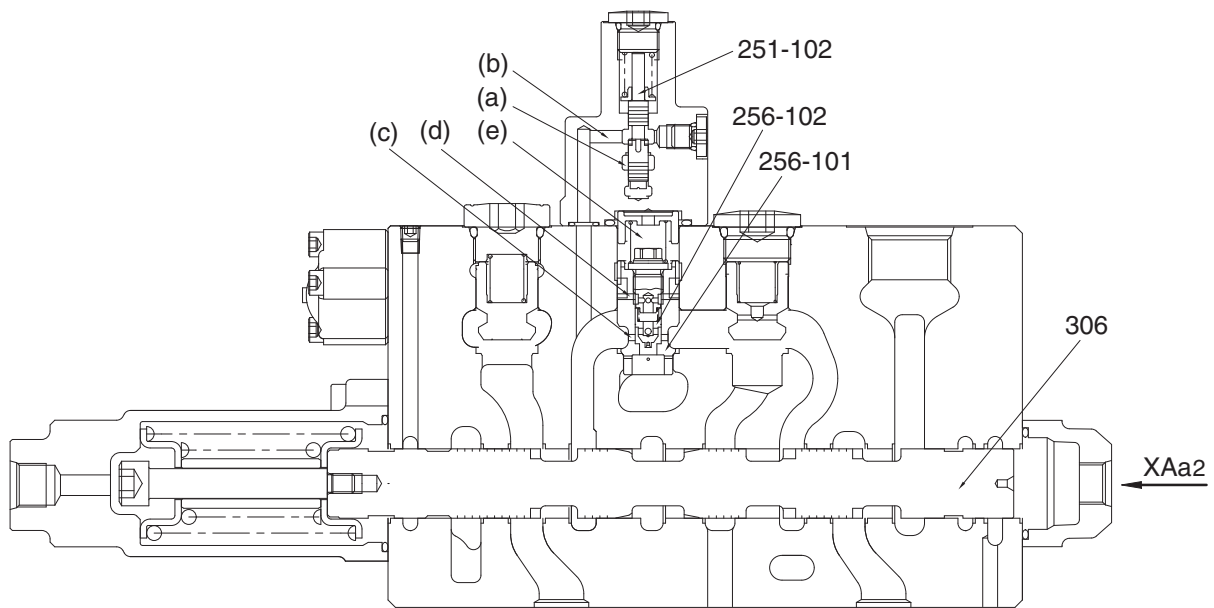

21092MC16

During both the arm in operation and the boom up operation, the pilot pressure enters through Ports XBa1, XBa2, XAb1, XAb2, PaL and PnA2. The pressure PnA2 transfers the spool (251-102) in the arm 2 logic control valve to the top direction, and the path from (a) to (b) is closed. Hereby, the pressurized oil pushes open the poppet (256-102), passes in the path (c) and (d), enters into the chamber (e), and the poppet (256-101) is pushed to the casing seat. Therefore, the most of pressurized oil entering through Port P2 flows to the boom 1 spool (303) than the arm 2 spool (306) to make the boom hoisting operation most preferential.

On the other hand, in the independent arm in operation, the pilot pressure does not enter through Ports PnA2, and the path from (a) to (b) is not closed, and the hydraulic oil of the chamber (e) flows to the path (a) and (b). The pressurized oil entering through Port P2 pushes open the poppet (256-101) and flows to the arm 2 spool (306).

### (3) Boom control

#### ① Boom up operation

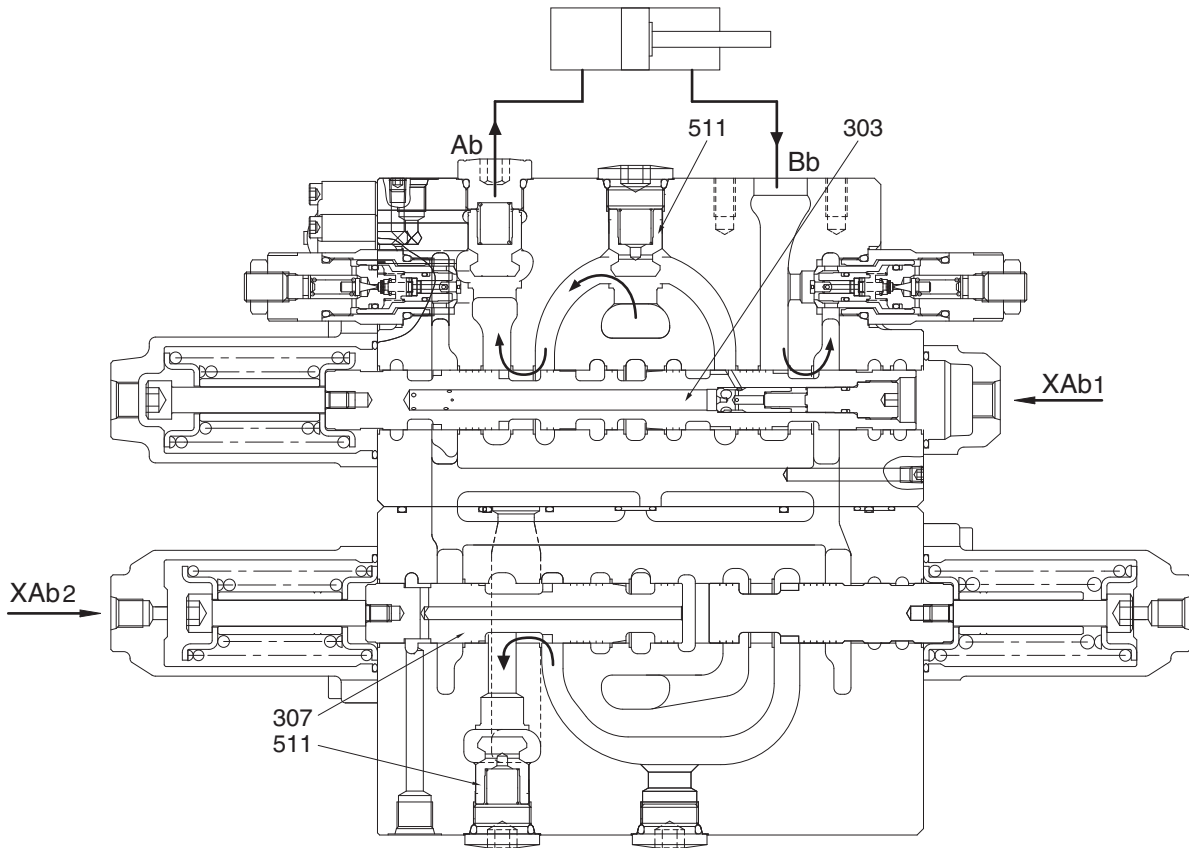

21092MC11

#### **Pilot circuit**

Since the boom 1 spool (303) transfers and shuts off the side-bypass path, the pressure at Port Px increases.

#### **Main circuit**

During the boom up operation, the pilot pressure enters through Port XAb1 and moves the boom 1 spool (303) in the left direction. The pressurized oil entering through Port P2 passes through the main path (3) and flows to the bypass circuit (2), but the bypass circuit (2) is shut off due to transfer of the boom 1 spool (303). Therefore, the pressurized oil flows into the parallel circuit, pushes open the check valve (511), and flows through the U-shaped path to the boom 1 spool (303). Then, it flows around the periphery of the boom 1 spool (303) to Port Ab, and is supplied to the boom cylinder head side.

At the same time, the pilot pressure enters also through Port XAb2 to transfer the boom 2 spool (307) in the right direction. Though the pressurized oil enters into Port P1, the bypass circuit (2) is shut off due to transfer of the boom 2 spool (307). Therefore, the hydraulic oil flows in the parallel circuit and flows through the U-shaped path to the boom 2 spool (307). Then, the hydraulic oil passes through the periphery of the boom 2 spool (307), pushes open the check valve (511), joins into Port Ab in the inside path, and is supplied to the boom cylinder head side. (Boom confluent flow)

On the other hand, the return oil from the boom cylinder rod side enters through Port Bb and returns to the hydraulic oil tank through the tank port (R1).



## ② Boom down operation

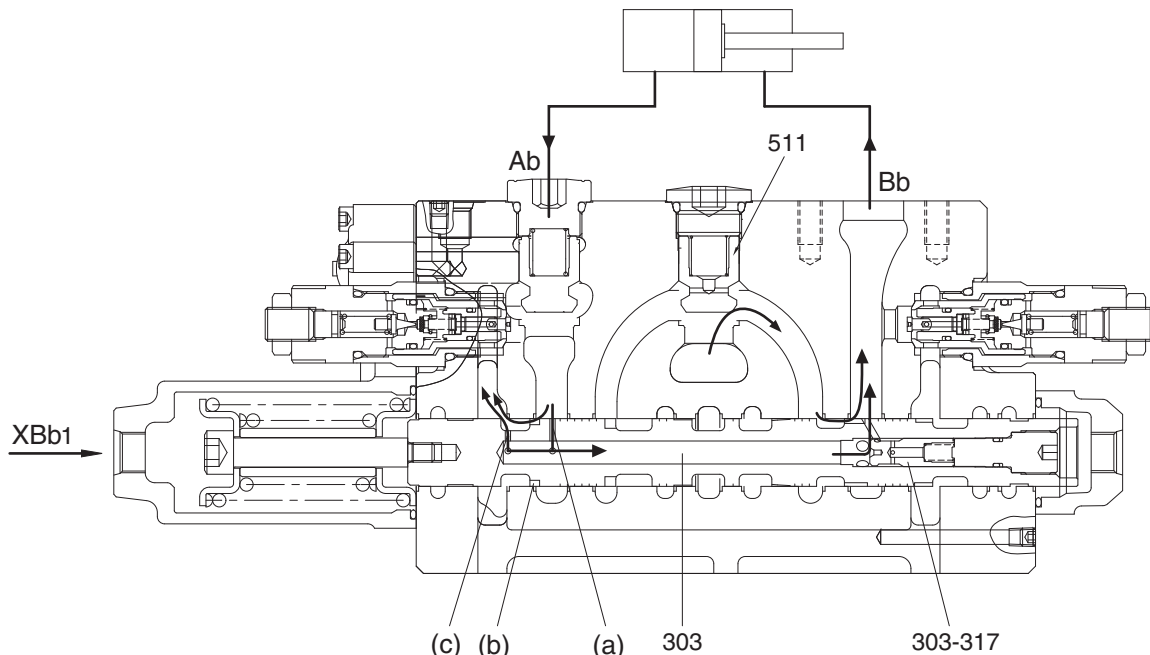

21092MC12

### Pilot circuit

Since the boom 1 spool (303) transfers and shuts off the side-bypass path, the pressure at Port Px increases. Then, the pressure enters also through Port PbL and the release signal is sent to the lock valve (252).

### Main circuit

During the boom down operation, the pilot pressure enters through Port XBb1 and transfers the boom 1 spool (303) in the right direction. The pressurized oil entering through Port P2 passes through the main path (3) and flows to the bypass circuit (2), but the bypass circuit (2) is shut off due to transfer of the boom 1 spool (303). Therefore, the pressurized oil flows into the parallel circuit, pushes open the check valve (511), and flows through the U-shaped path to the boom 1 spool (303). Then, it flows around the periphery of the boom 1 spool (303) to Port Bb and is supplied to the boom cylinder rod side.

On the other hand, the return oil from the boom cylinder head side passes to the holes (a) and the notches (b) of the boom 1 spool (303).

Since this return oil has a sufficient pressure caused by the weight of the boom, it passes through the path inside the spool, pushes the poppet (303-317) in the spool in the right direction, flows around the outside of the spool. Then, it is supplied again to the boom cylinder rod side as hydraulic oil to lower the boom. (Boom regeneration)

Besides, a part of the return oil from the boom cylinder flows from the hole (c) into the tank.

#### (4) Bucket control

##### ① Bucket in operation

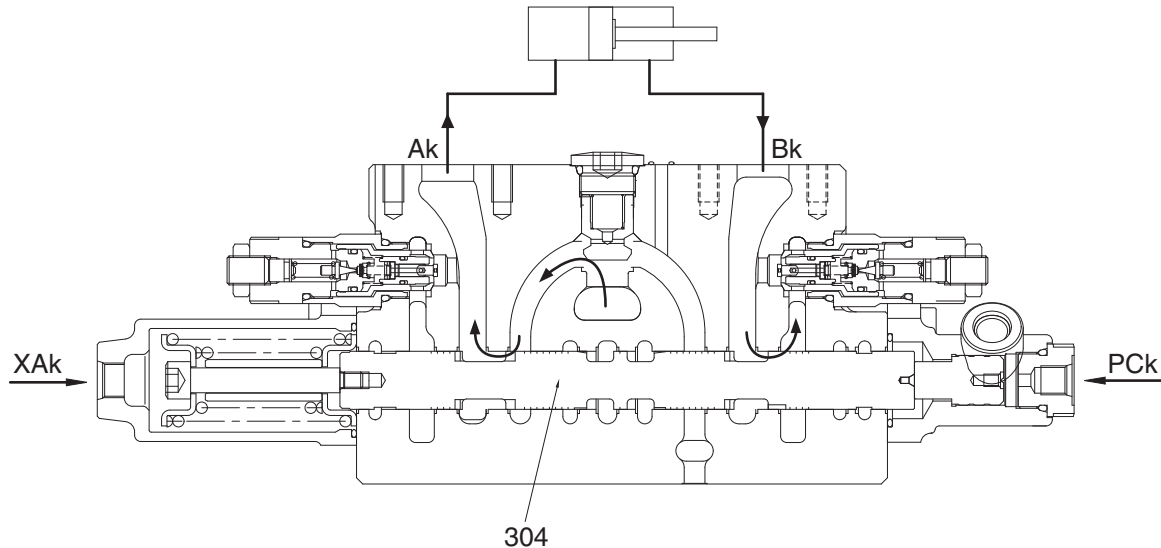

21092MC17

#### **Pilot circuit**

Since the bucket spool (304) transfers and shuts off the side-bypass path, the pressure at Port Px increases. Then, the pressure enters also through Port XBp1.

#### **Main circuit**

During the bucket in operation, the pilot pressure enters through Port XAk and transfers the bucket spool (304) in the right direction. The pressurized oil entering through Port P2 passes through the main path (3) and flows through the bypass circuit (2), but the bypass circuit (2) is shut off due to transfer of the bucket spool (304). Therefore, the pressurized oil flows into the parallel circuit, pushes open the check valve (511), and flows through the U-shaped path to the bucket spool (304). Then, it flows through the periphery of the spool to Port Ak and is supplied to the bucket cylinder head side.

On the other hand, the return oil from the bucket cylinder rod side enters through Port Bk, passes around the periphery of the spool, and returns to the hydraulic oil tank through the tank port (R1).

During both the boom up operation and bucket in operation, the pilot pressure enters through Port PCk and the bucket spool transfers in the half stroke not full stroke. Therefore, the most of pressurized oil entering through Port P2 flows to the boom 1 spool (303) than the bucket spool (304) to make the boom up operation most preferential.

## ② Bucket out operation

### Pilot circuit

Since the bucket spool (304) transfers and shuts off the side-bypass path, the pressure at Port Px increases.

### Main circuit

During the bucket out operation, the pilot pressure enters through Port XBk and transfers the bucket spool (304) in the left direction. The pressurized oil entering through Port P2 passes through the main path (3) and flows through the bypass circuit (2), but the bypass circuit (2) is shut off due to transfer of the bucket spool (304). Therefore, the pressurized oil flows into the parallel circuit, pushes open the check valve (511), and flows through the U-shaped path to the bucket spool (304). Then, it flows through the periphery of the spool to Port Bk and is supplied to the bucket cylinder rod side.

On the other hand, the return oil from the bucket cylinder head side enters through Port Ak, passes around the periphery of the spool, and returns to the hydraulic oil tank through the tank port (R1).

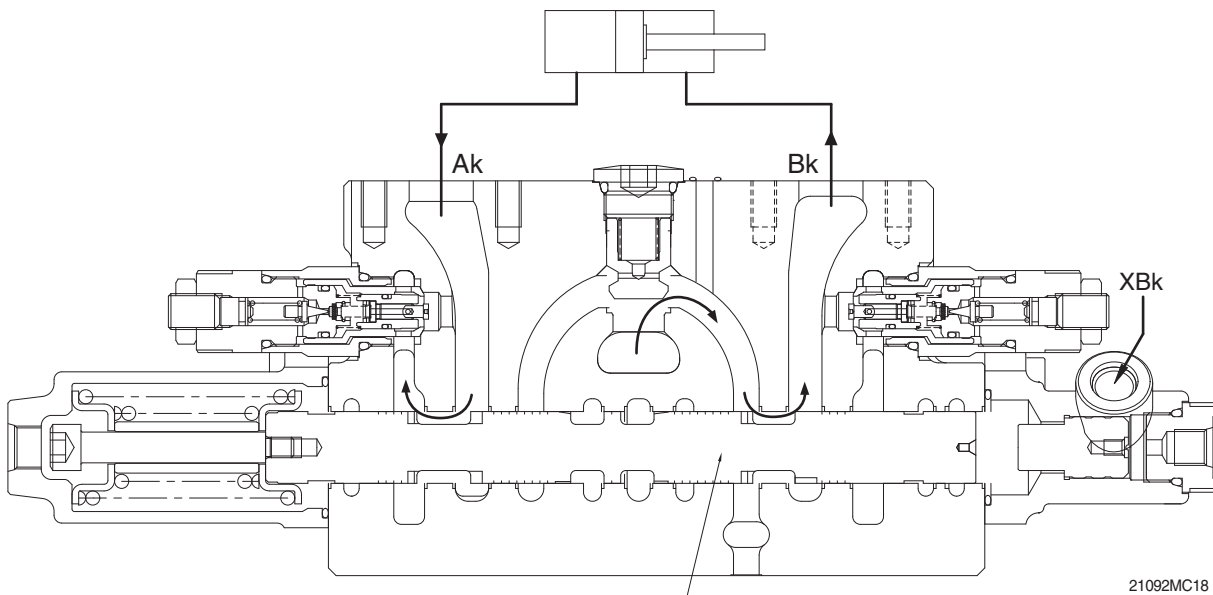

## ③ Bucket in confluence

During the bucket in operation, the pilot pressure enters also through Port XBp1 and transfers the bypass-cut spool (313). The pressurized oil entering through Port P1 passes through the main path (1) and flows through the bypass circuit (2), but the bypass circuit (2) is shut off due to transfer of the bypass-cut spool (313). Therefore, the pressurized oil pushes open the check valve CCK (514), and flows through inside path and the U-shaped path to the bucket spool (304).

## (5) Swing control

### ① Swing operation

#### Pilot circuit

Since the swing spool (305) transfers and shuts off the side-bypass path, the pressure at Port Px increases.

#### Main circuit

During the swing operation, the pilot pressure enters through Port XAs (or XBs) and transfers the swing spool (305). The pressurized oil entering through Port P1 passes through the main path (1) and flows through the bypass circuit (2), but the bypass circuit (2) is shut off due to transfer of the swing spool (305). Therefore, the pressurized oil flows into the parallel circuit, pushes open the check valve (511), and flows through the U-shaped path to the swing spool (305). Then, it flows through the periphery of the spool to Port As (or Bs) and is supplied to the swing motor.

On the other hand, the return oil from the swing motor enters Port Bs (or As) and returns to the hydraulic oil tank through the tank port (R1).

### ② Swing logic control valve operation

During both the swing operation and the boom up operation, the pilot pressure enters through Ports XBs (or XAs), XAb1, XAb2 and Pns. The pressure Pns transfers the spool (250-102) in swing logic control valve. Hereby, the pressurized oil pushes open the poppet (254-102), and the poppet (254-101) is pushed to the casing seat. Therefore, the most of pressurized oil entering through Port P1 flows to the boom 2 spool (307) than the swing spool (305) to make the boom up operation most preferential.

On the other hand, in the independent swing operation, the pilot pressure does not enter through Ports Pns. The pressurized oil entering through Port P1 pushes open the poppet (254-101) and flows to the swing spool (305).

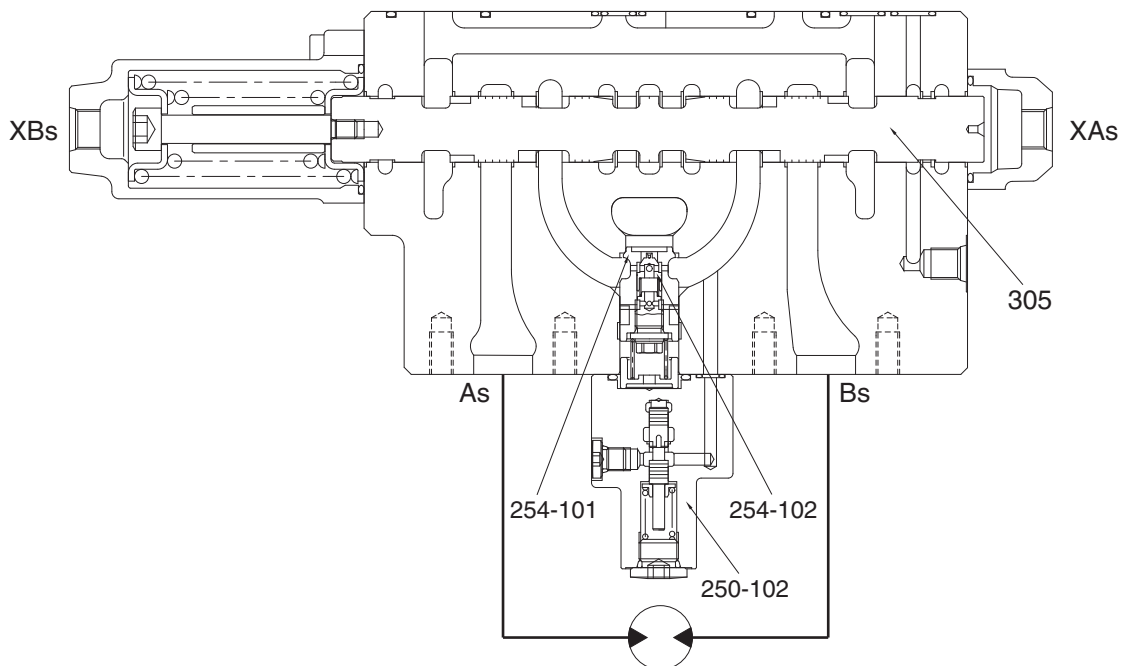

21092MC19

### ③ Swing operation preference function

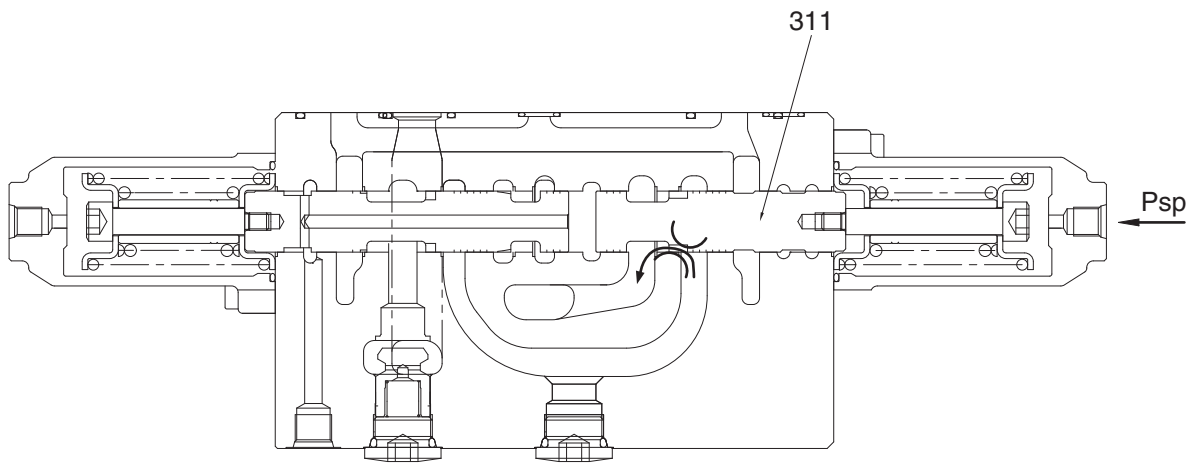

21092MC20

#### **Pilot circuit**

The pilot pressure enters through Port Psp to transfer the swing priority spool (311).

#### **Main circuit**

Due to transfer of the swing priority spool (311), the open area of the swing priority spool decreases, and the most of the pressurized oil entering through Port P1 flows to the swing side to make the swing operation most preferential.

### (6) Travel straight operation

Simultaneous operating of both travel spools (301, 314) and other spool.

A case where both travel spools (301, 314) and swing spool (305) are changed over will be considered.

(The pilot Ports XAtL, XAtR and XAs are pressurized.)

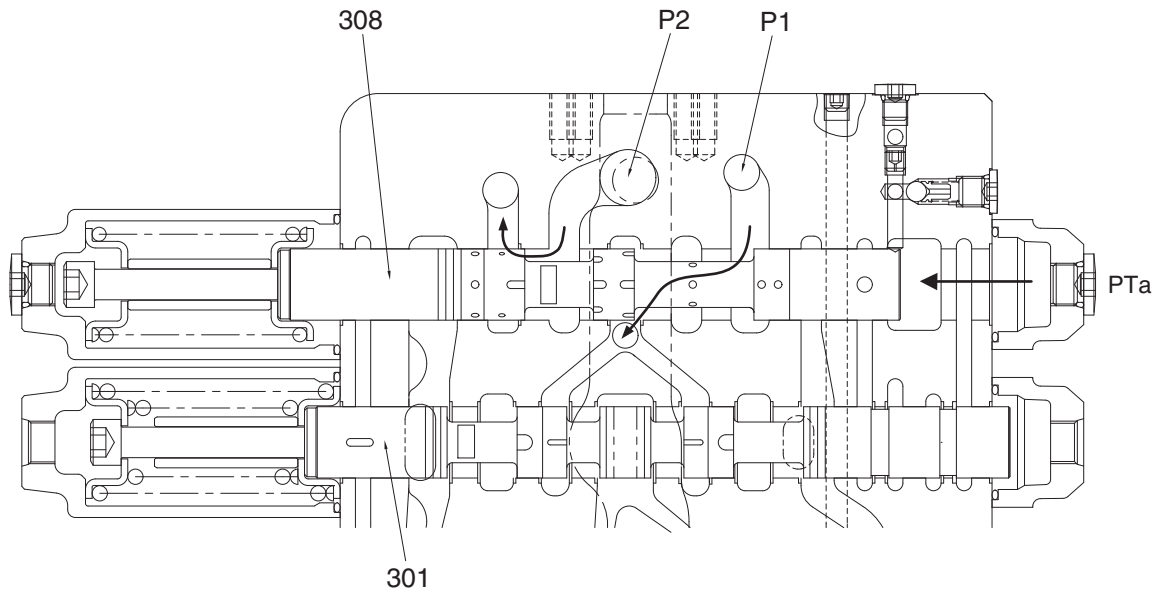

21092MC22

#### Pilot circuit

Since the side bypass sections of both travel spools (301, 314) close and the side bypass section of the downstream-side swing closes, the pilot pressure from the port PG enters through the port PTa to transfer the travel straight spool (308).

#### Main circuit

After changeover of the travel straight spool (308), the port P1 and both travel spools (301, 314) are connected preferentially and the port P2 and the parallel paths of swing, boom 2, option and arm 1 / boom 1, bucket and arm 2 are connected preferentially. Therefore, the pressurized oil entering through Port P1 passes through mainly ports AtL and Atr, and flows to both travel motors separately.

On the other hand, the pressurized oil entering through Port P2 flows to Port As and is supplied to the swing motor.

When the pressure of Port P1 is lower than the pressure of Port P2, the part of oil entering through Port P2 flows into Port P1 side. Therefore, it prevents the rapid slowdown of the travel.

### 3) FUNCTION OF LOCK VALVE

The lock valve (252) is fitted between the arm cylinder rod side and the arm 2 spool (306). It decreases the leakage by the pressure of the cylinder.

Another lock valve (252) is similarly fitted between the boom cylinder head side and the boom 1 spool (303). It decreases the leakage by the pressure of the cylinder.

#### (1) Neutral positions of spools

The following is the case of the boom 1 spool (303). (The case of the arm 2 spool (306) is in the same way.)

During the boom 1 spool (303) is in the neutral position, the lock valve (252) is kept in the position shown in figure. The spool (252-511) in the lock valve is pushed to the seat of the sleeve (252-541) by the force of the spring (252-321).

In this position, the pressurized oil from the boom cylinder head side enters through the hole (a), the periphery of the spool (252-511) in the lock valve and the hole (b), and it pushes the poppet (513) to the casing seat, and the leakage is decreased.

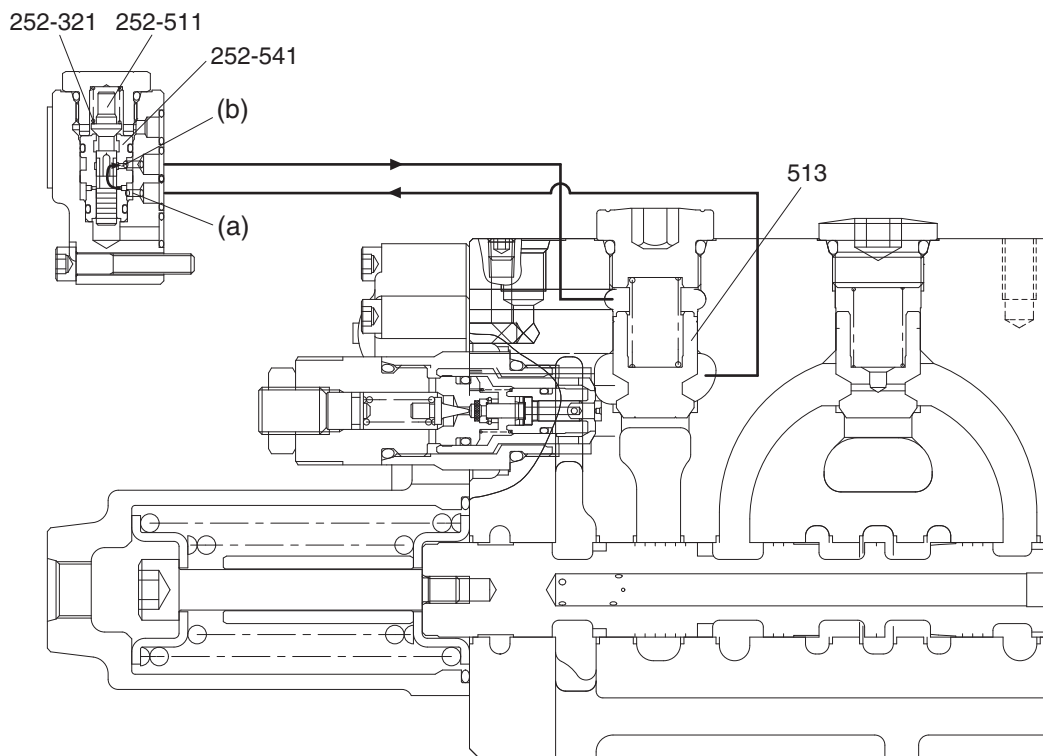

21092MC35

## (2) Boom down operation

During the boom down operation, the pilot pressure enters through Port PbL and XBb1. The pilot pressure transfers the spool (252-511) in the lock valve assy in the top direction. By the transfer of the spool (252-511), firstly the hole (a) is blocked and the pressurized oil from the boom cylinder head side does not enter to the spring chamber (RH). Secondly, the oil in the spring chamber (RH) enters through the hole (b) and flows to drain circuit. Therefore, the poppet (513) is lifted by the pressure of the boom cylinder head side and the function of the lock valve (252) is released.

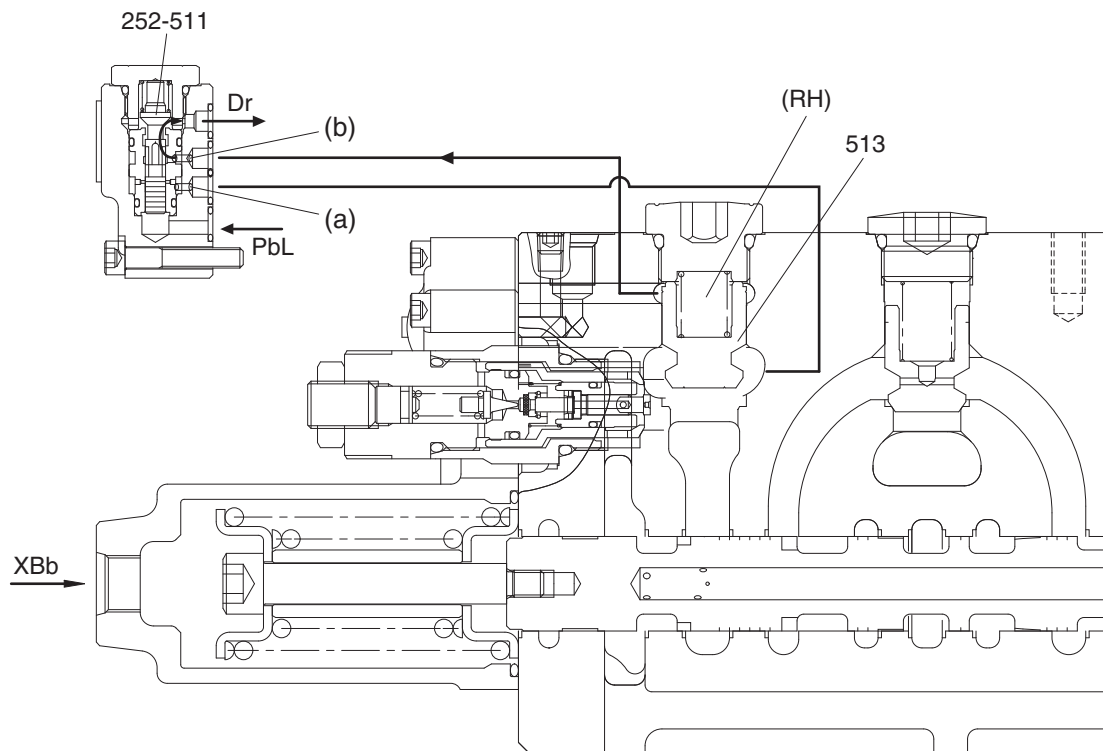

21092MC36

## (3) Boom up operation

During the boom up operation, the pilot pressure enters through Port XAb1. The oil flowing from the boom 1 spool pushes open the poppet (513) and flows to Port Ab.



## 5) CIRCUIT PRESSURE PROTECTION

The control valve has two kinds of relief valve to limit the pressure in a circuit.

### (1) Main relief valve

The main relief valve is fitted in the casing A and functions as follows.

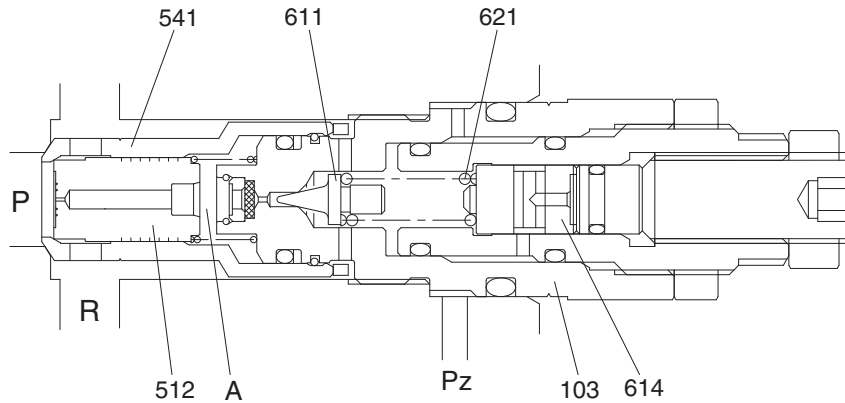

21092MC25

- ① The hydraulic oil is filled up in the inside space chamber (A) from the path (P) through a hole of the seat (541) and a restriction of the plunger (512), and seats the plunger (512) against the seat (541) securely.
- ② When the pressure in the path (P) becomes equal to the set load of the spring (621), the poppet (611) opens to make the hydraulic oil flow through a hole of the plug (103), around the poppet (611) and into the low pressure path (R).
- ③ Opening of the poppet (611) causes the pressure in the chamber (A) to fall and the plunger (512) to open. As the result the pressurized oil in the path (P) runs into the low pressure path (R) directly.
- ④ When the pressurized oil higher than pressure 30 kgf/cm<sup>2</sup> enters through the port Pz, it pushes the piston (614) to change the relief set pressure of the spring (621) to the high pressure.

## (2) Port relief valve

The port relief valve is fitted between the cylinder port and low-pressure path. In addition to the relief valve, this serves also as an anti-cavitation check valve, and functions as follows:

### ① Function as relief valve

- a. The pressurized oil passes through Hole A of the piston (301), is filled up in Chamber B of the inside space, and seat the plunger (511) against the seat (541) securely.

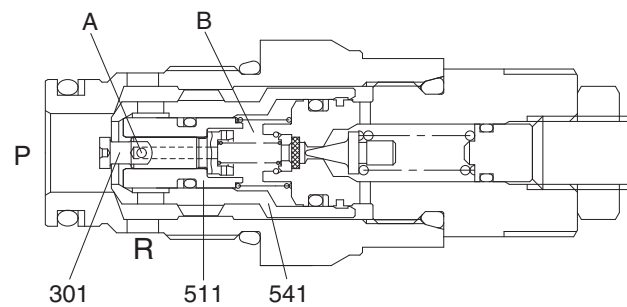
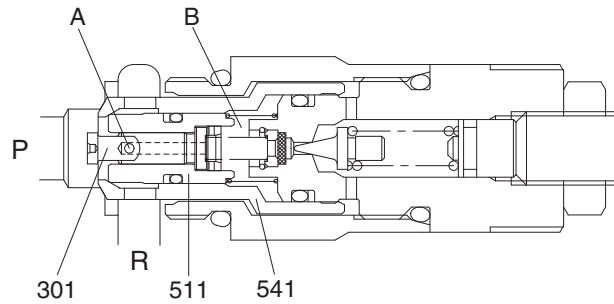

330F2MC06

- b. When the pressure in the path (P) becomes equal to the set pressure of the spring (621 or 622), the pressurized oil pushes open the poppet (611), flows around it, and flows to the low pressure path (R) through hole C.

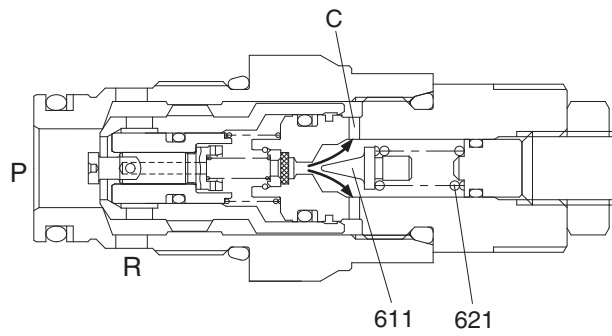
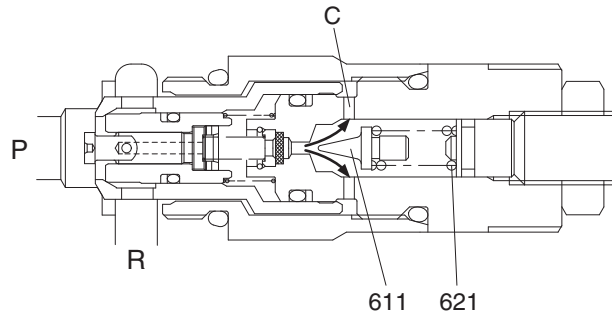

330F2MC07

- c. Opening of the poppet (611) causes the pressure in Chamber B to fall and the plunger (511) to open. As the result the pressurized oil in the path (P) runs into the low pressure path (R) directly.

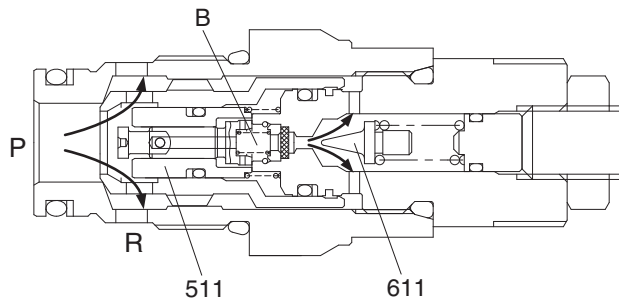
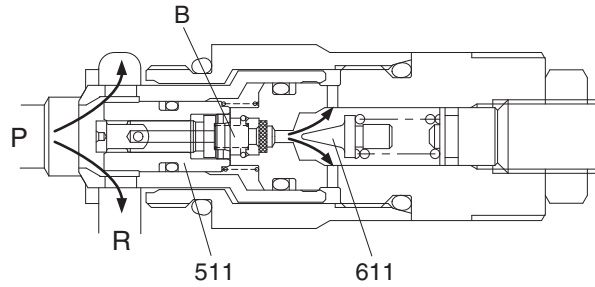

330F2MC08

② **Function as Anti-Cavitation Check Valve**

When any negative pressure exists in the path (P), the oil is supplied through the path (R). When the pressure at (R) becomes higher than that in the path (P), the seat (541) moves in the right direction. Then, sufficient oil passes around the seat (541) from the path (R) to the path (P) and prevents cavitation.

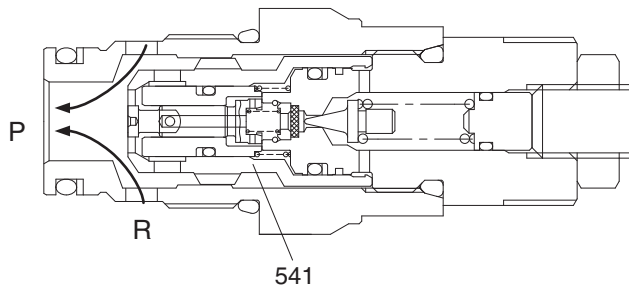
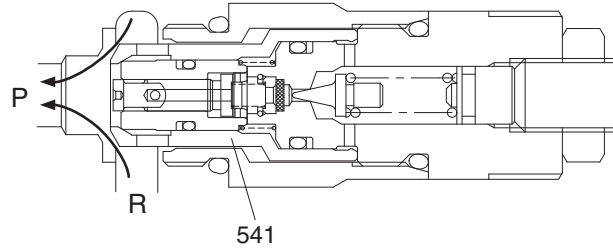

330F2MC09

### (3) Negative control relief valve

The negative control relief valve is fitted between the downstream of the center bypass path and low-pressure path, and functions as follows.

- ① When the pressure in the path (P) falls below the set level of the spring (321), the poppet (511) is in the condition shown in the figure. The pressure acting area of the poppet (511) is reduced to  $(\phi B - \phi A)$ , as the area  $\phi B$  is cancelled by the area  $\phi A$  of the damping rod (512).

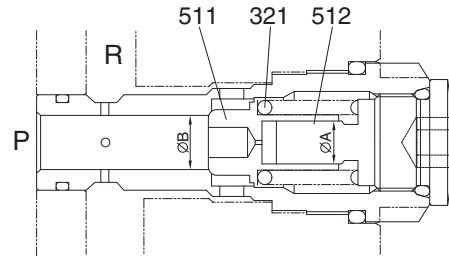

32092MC07

- ② In this condition, the pressurized oil in the path (P) runs out to the path (R) through the orifice (c).

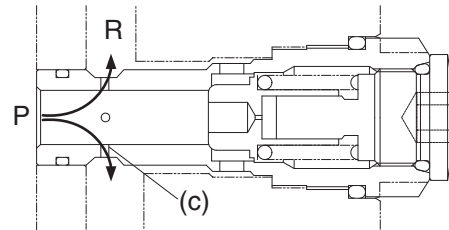

32092MC08A

- ③ When the pressure in the path (P) goes over the set P pressure of the spring (321), the poppet (511) opens. Then, the pressurized oil in the path (P) passes around the outside of the poppet (511) and flows to the low-pressure path (R).

The relation between the flow rate Q and pressure P of the hydraulic oil that flows from the path (P) to the low-pressure path (R) is as shown in the diagram.

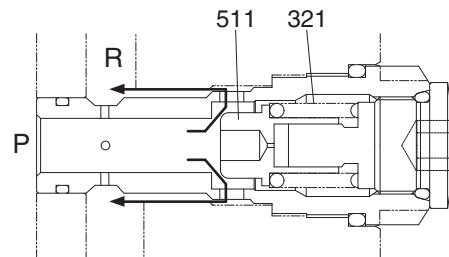

32092MC09A

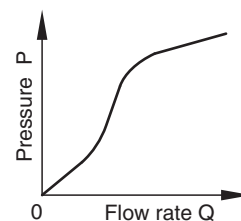

32092MC10

## GROUP 3 SWING DEVICE

### 1. STRUCTURE

Swing device consists swing motor, swing reduction gear.

Swing motor include mechanical parking valve, relief valve, make up valve and time delay valve.

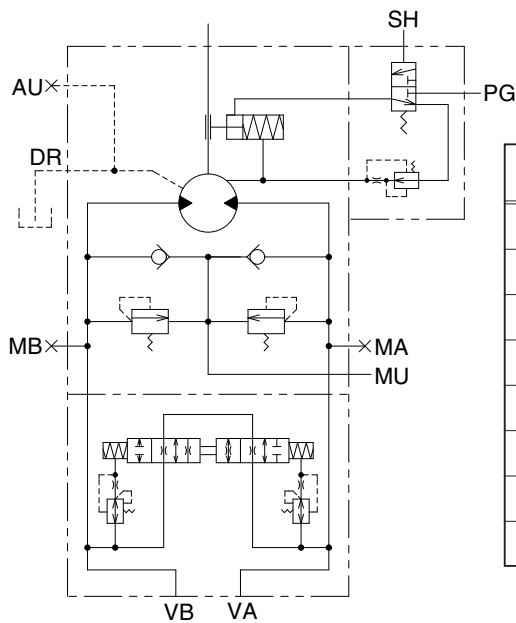
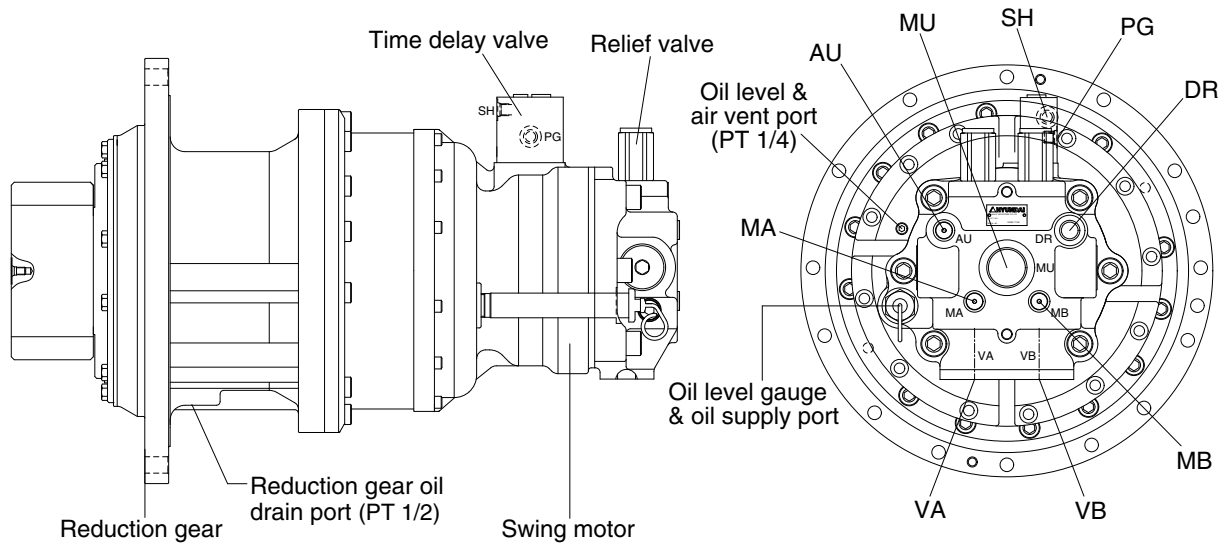

Hydraulic circuit

Port	Port name	Port size
VA	Main port	ø 20
VB	Main port	ø 20
DR	Drain port	PF 1/2
MU	Make up port	PF 1 1/4
PG	Brake release stand by port	PF 1/4
SH	Brake release port	PF 1/4
MA, MB	Gauge port	PF 1/4
AU	Air vent port	PF 1/4

300L2SM01

## 1) SWING MOTOR

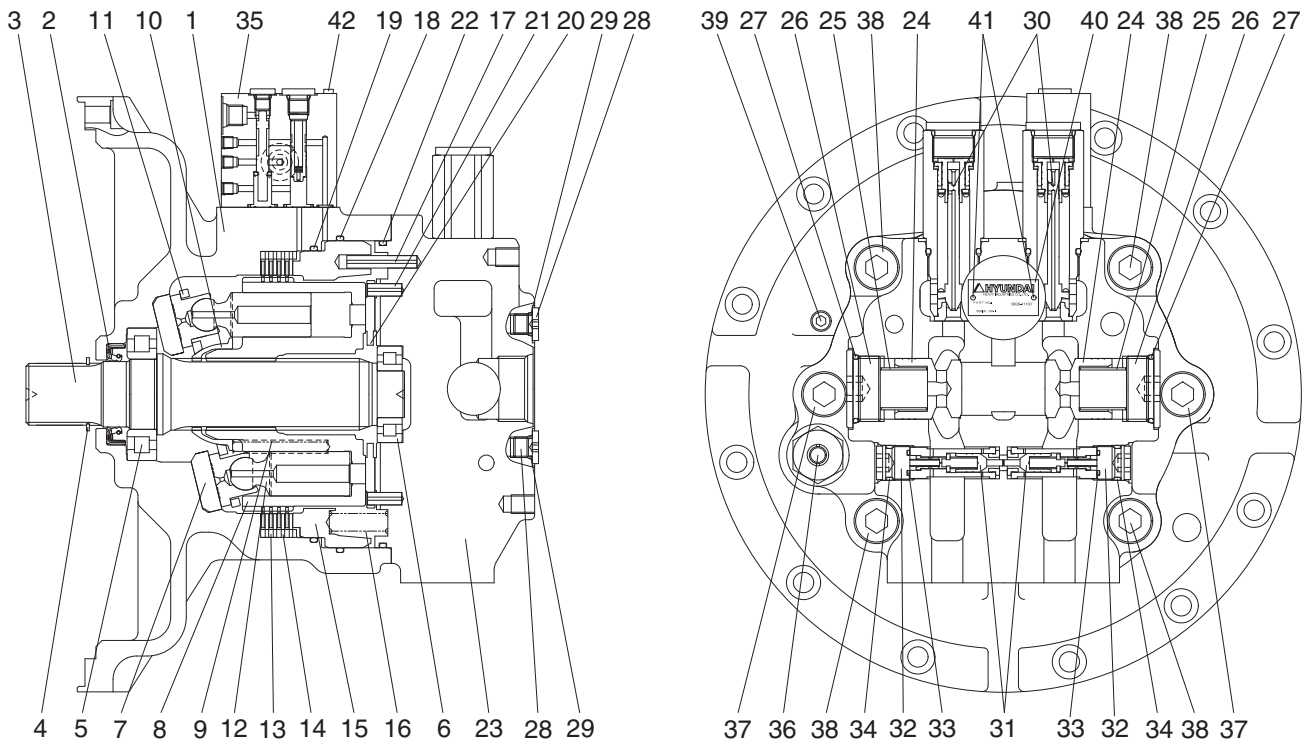

300L2SM02

1	Casing	15	Parking piston	29	O-ring
2	Oil seal	16	Brake spring	30	Relief valve assy
3	Shaft	17	Spring pin	31	Reactionless valve assy
4	Snap ring	18	O-ring	32	Plug
5	Roller bearing	19	O-ring	33	O-ring
6	Needle bearing	20	Valve plate	34	O-ring
7	Swash plate	21	Spring pin	35	Time delay valve assy
8	Cylinder block	22	O-ring	36	Level gauge
9	Spring	23	Valve casing	37	Socket bolt
10	Ball guide	24	Check valve	38	Socket bolt
11	Retainer plate	25	Spring	39	Plug
12	Piston assy	26	Plug	40	Name plate
13	Friction plate	27	O-ring	41	Rivet
14	Separate plate	28	Plug	42	Socket bolt



## 2) REDUCTION GEAR

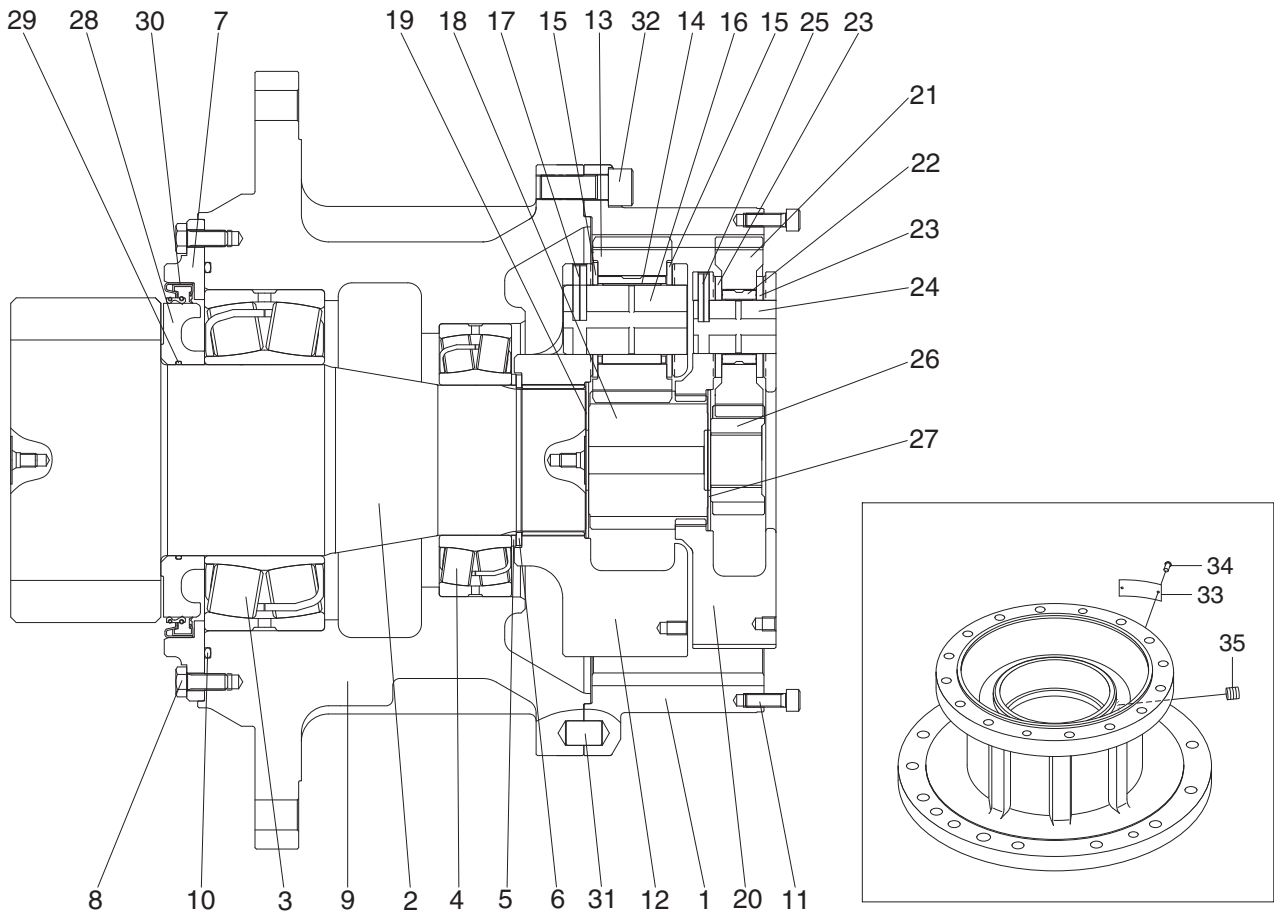

300L2SM03

- |    |                      |    |                  |    |                      |
|----|----------------------|----|------------------|----|----------------------|
| 1  | Ring gear            | 13 | Planetary gear 2 | 25 | Spring pin 1         |
| 2  | Drive shaft          | 14 | Needle bearing 2 | 26 | Sun gear 1           |
| 3  | Bearing              | 15 | Thrust washer 2  | 27 | Thrust plate 1       |
| 4  | Bearing              | 16 | Carrier pin 2    | 28 | Sleeve               |
| 5  | Thrust plate         | 17 | Spring pin 2     | 29 | O-ring               |
| 6  | Snap ring            | 18 | Sun gear 2       | 30 | Oil seal             |
| 7  | Cover                | 19 | Thrust plate 2   | 31 | Parallel pin         |
| 8  | Hex head bolt        | 20 | Carrier 1        | 32 | Hex socket head bolt |
| 9  | Casing               | 21 | Planetary gear 1 | 33 | Name plate           |
| 10 | O-ring               | 22 | Needle bearing 1 | 34 | Rivet                |
| 11 | Hex socket head bolt | 23 | Thrust washer 1  | 35 | Plug                 |
| 12 | Carrier 2            | 24 | Carrier pin 1    |    |                      |

## 2. PRINCIPLE OF DRIVING

### 2.1 Generating the turning force

The high hydraulic supplied from a hydraulic pump flows into a cylinder block (8) through valve casing of motor (1), and valve plate (20).

The high hydraulic is built as flowing on one side of Y-Y line connected by the upper and lower sides of piston (12).

The high hydraulic can generate the force,  $F1 = P \times A$  ( $P$  : supplied pressure,  $A$  : water pressure area), like following pictures, working on a piston.

This force,  $F1$ , is divided as  $N1$  thrust partial pressure and  $W1$  radial partial pressure, in case of the plate of a tilt angle,  $\alpha$ .

$W1$  generates torque,  $T = W1 \times R1$ , for Y-Y line connected by the upper and lower sides of the piston as following pictures.

The sum of torque ( $\sum W1 \times R1$ ), generated from each piston (4~5 pieces) on the side of a high hydraulic, generates the turning force.

This torque transfers the turning force to a cylinder (8) through a piston; because a cylinder is combined with a turning axis and spline, a turning axis rotates and a turning force is sent.

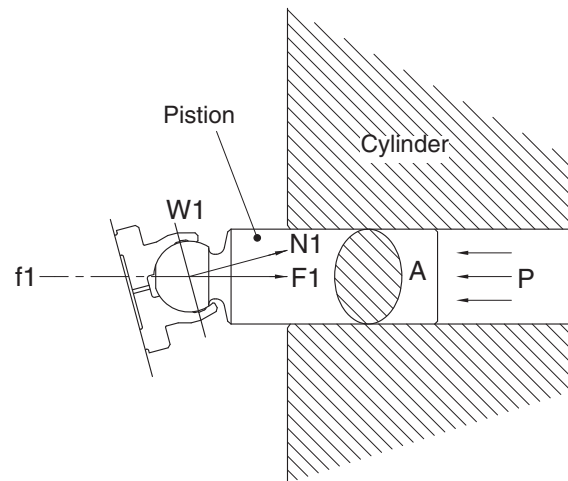
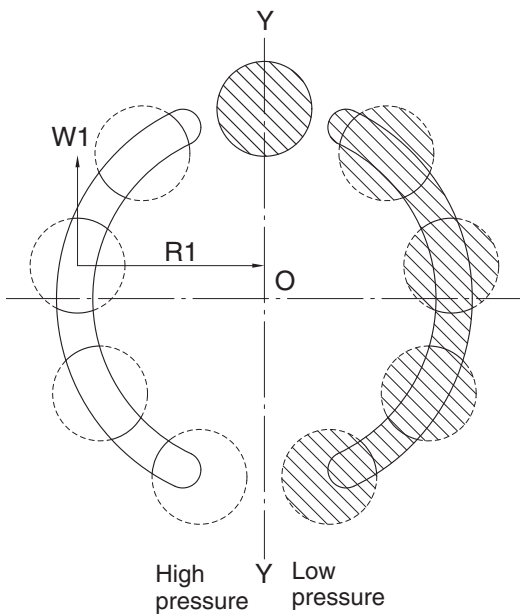

21078TM05

## 2) MAKE UP VALVE

In the system using this type of motor, there is no counter balance functioning valve and there happens the case of revolution exceeding hydraulic supply of motor. To prevent the cavitation caused by insufficient oil flow there is a make up valve to fill up the oil insufficiency.

A make up valve is provided immediately before the port leading to the hydraulic oil tank to secure feed pressure required when the hydraulic motor makes a pumping action. The boost pressure acts on the hydraulic motor's feed port via the make up valve.

Pressurized oil into the port B, the motor rotate counterclockwise.

If the plunger of MCV moves neutral position, the oil in the motor is drain via left relief valve, the drain oil run into motor via right make up valve, which prevent the cavitation of motor.

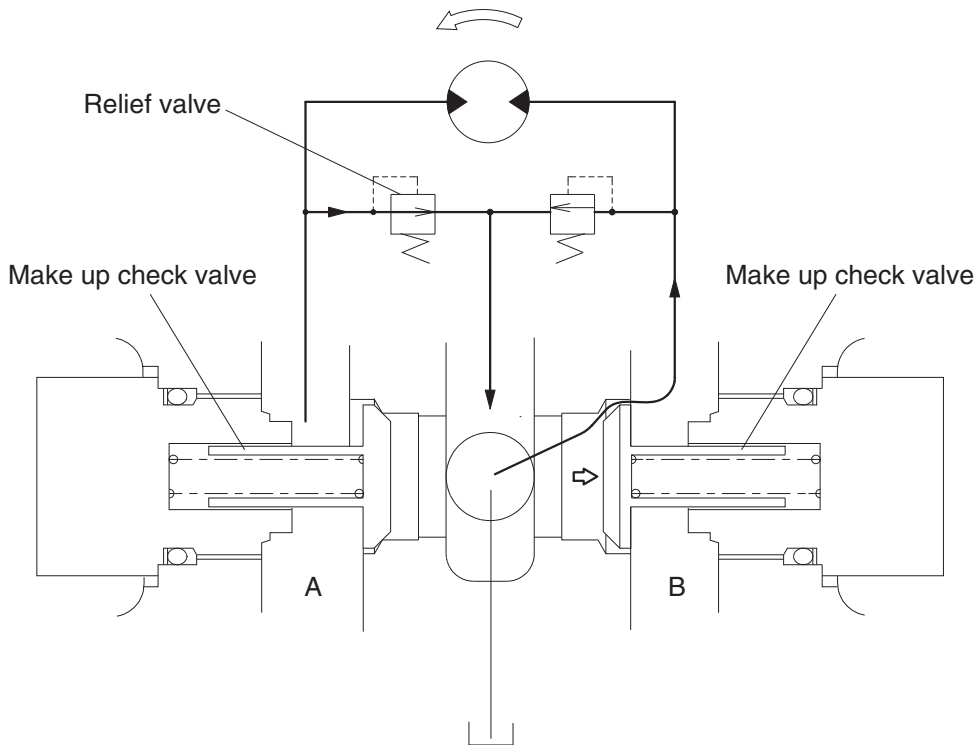

21092SM04

### 3) RELIEF VALVE

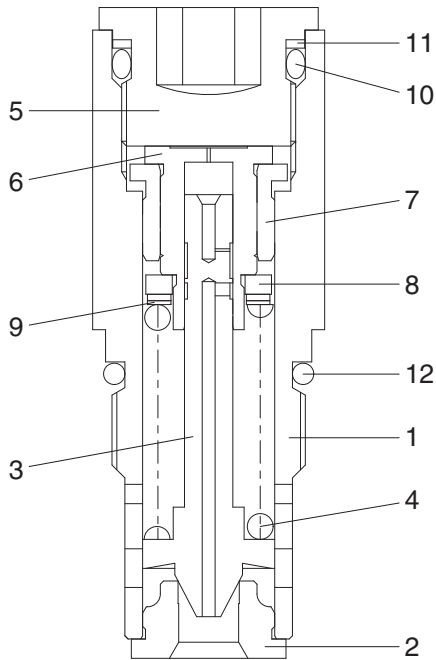

- 1 Body
- 2 Seat
- 3 Plunger
- 4 Spring
- 5 Adjusting screw
- 6 Piston
- 7 Bushing
- 8 Spring seat
- 9 Shim
- 10 O-ring
- 11 Back up ring
- 12 O-ring

14007A2SM05

#### (1) Construction of relief valve

The valve casing contains two cartridge type relief valves that stop the regular and reverse rotations of the hydraulic motor. The relief valves relieve high pressure at start or at stop of swing motion and can control the relief pressure in two steps, high and low, in order to insure smooth operation.

#### (2) Function of relief valve

Figure illustrates how the pressure acting on the relief valve is related to its rising process. Here is given the function, referring to the figure following page.

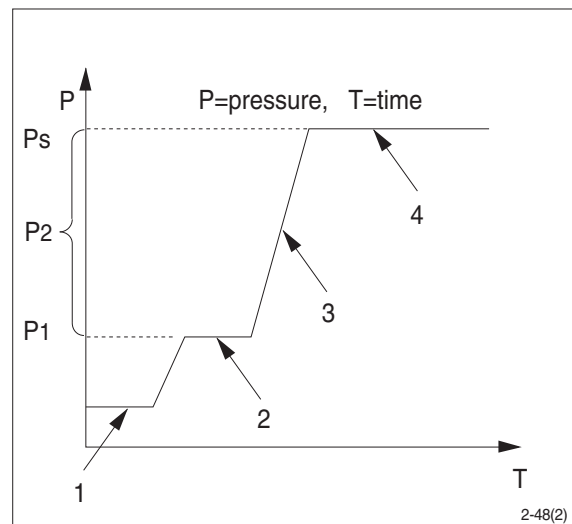

2-48(2)

① Ports (P,R) at tank pressure.

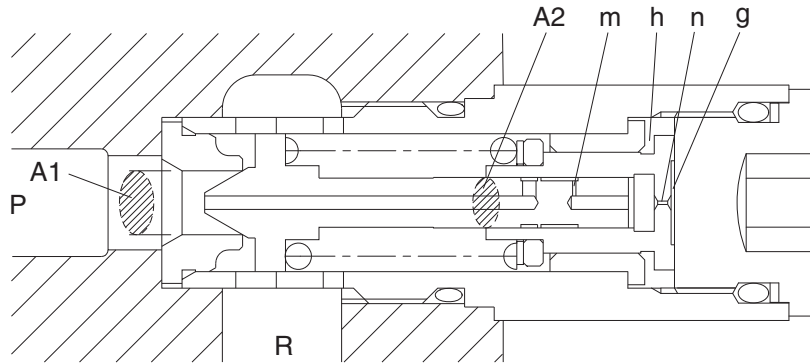

14007A2SM06

② When hydraulic oil pressure ( $P \times A_1$ ) reaches the preset force ( $F_{SP}$ ) of spring (4), the plunger (3) moves to the right as shown.

$$P_1 \times A_1 = F_{SP} + P_g \times A_2$$

$$P_1 = \frac{F_{SP} + P_g \times A_2}{A_1}$$

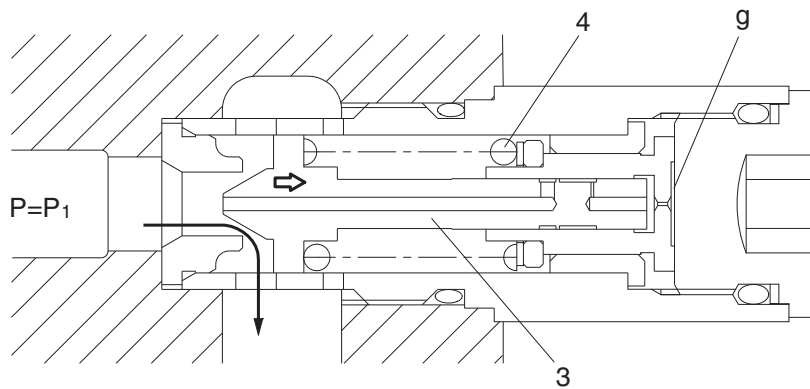

14007A2SM07

- ③ The oil flow chamber g via orifice m and n. When the pressure of chamber g reaches the preset force (F<sub>SP</sub>) of spring (4), the piston (6) moves left and stop the piston (6) hits the bottom of bushing (7).

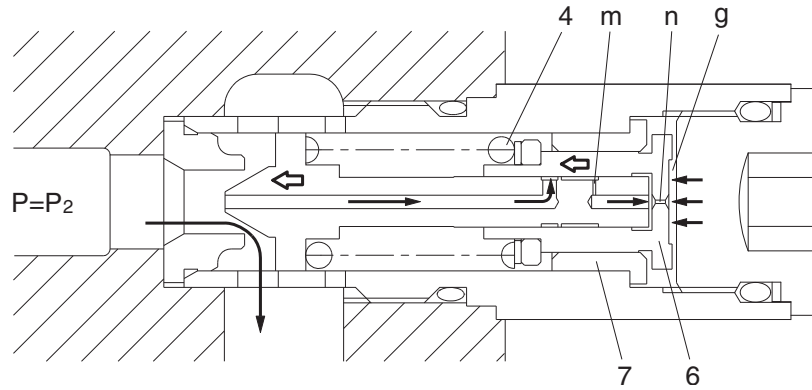

14007A2SM08

- ④ When piston (6) hits the bottom of bushing (7), it stops moving to the left any further. As the result, the pressure in chamber (g) equals (P<sub>s</sub>).

$$P_s \times A_1 = F_{sp} + P_s \times A_2$$

$$P_s = \frac{F_{sp}}{A_1 - A_2}$$

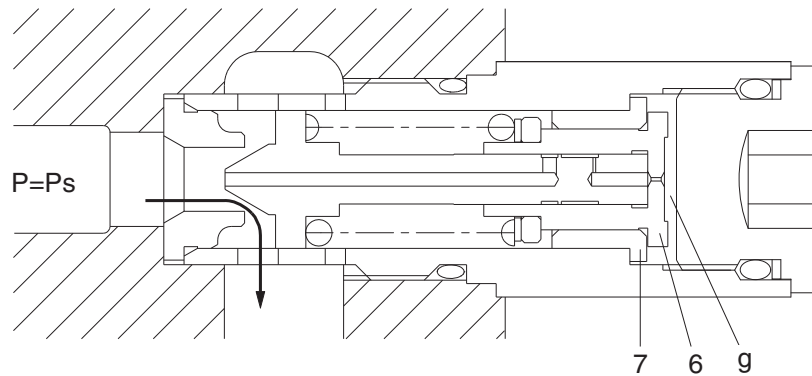

14007A2SM09

## 4) BRAKE SYSTEM

### (1) Control valve swing brake system

This is the brake system to stop the swing motion of the excavator during operation.

In this system, the hydraulic circuit is throttled by the swing control valve, and the resistance created by this throttling works as a brake force to slow down the swing motion.

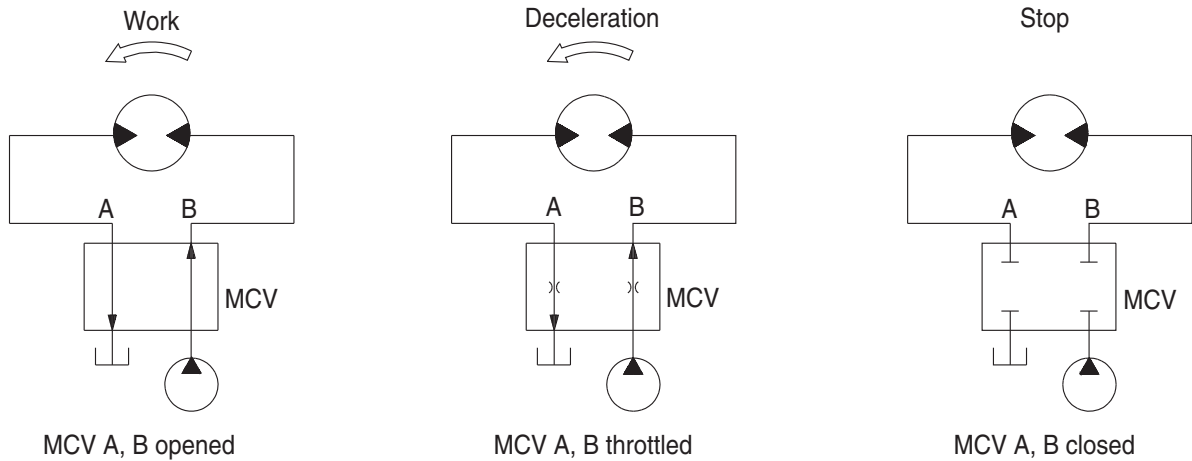

2-48(1)

### (2) Mechanical swing parking brake system

This is function as a parking brake only when all of the RCV lever (except travel pedal) are not operated.

#### ① Brake assembly

Circumferential rotation of separate plate (16) is constrained by the groove located at housing (1). When housing is pressed down by brake spring (20) through friction plate (15), separate plate (16) and brake piston (17), friction force occurs there.

Cylinder block (10) is constrained by this friction force and brake acts, while brake releases when hydraulic force exceeds spring force.

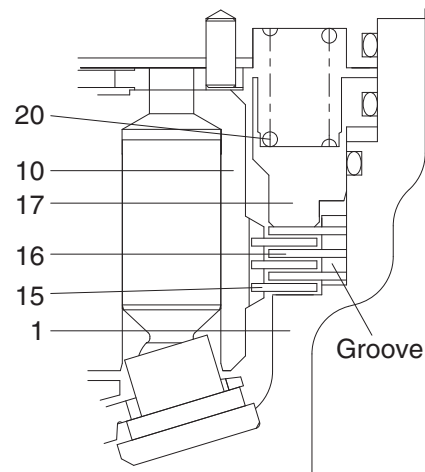

21092SM15

1	Housing	16	Separate plate
10	Cylinder block	17	Brake piston
15	Friction plate	20	Spring

② **Operating principle**

- a. When one of the RCV lever (1) is set to the operation position, the each spool is shifted to left or right and the pilot oil flow is blocked. Then the pilot oil go to SH of the time delay valve (35). This pressure moves spool (5) to the leftward against the force of the spring(8), so pilot pump charged oil (P3) goes to the chamber G through port PG. This pressure is applied to move the piston (17) to the upward against the force of the spring (20). Thus, it releases the brake force.

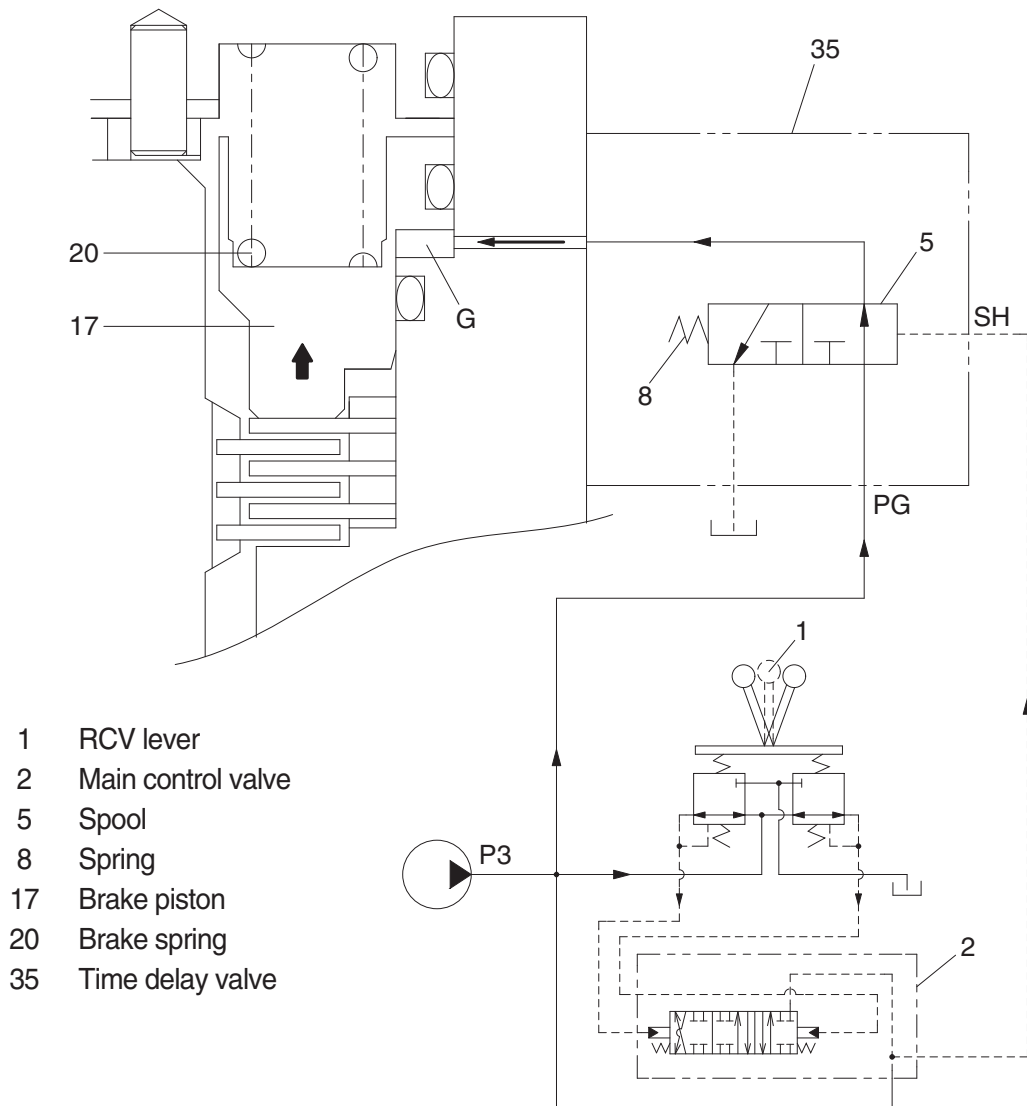

21092SM16



- b. When all of the RCV lever (1) are set the neutral position, the spool (5) returns to right. Then, the brake piston (17) is moved lower by spring force and the return oil from the chamber G flows back to tank port. At this time, the brake works.

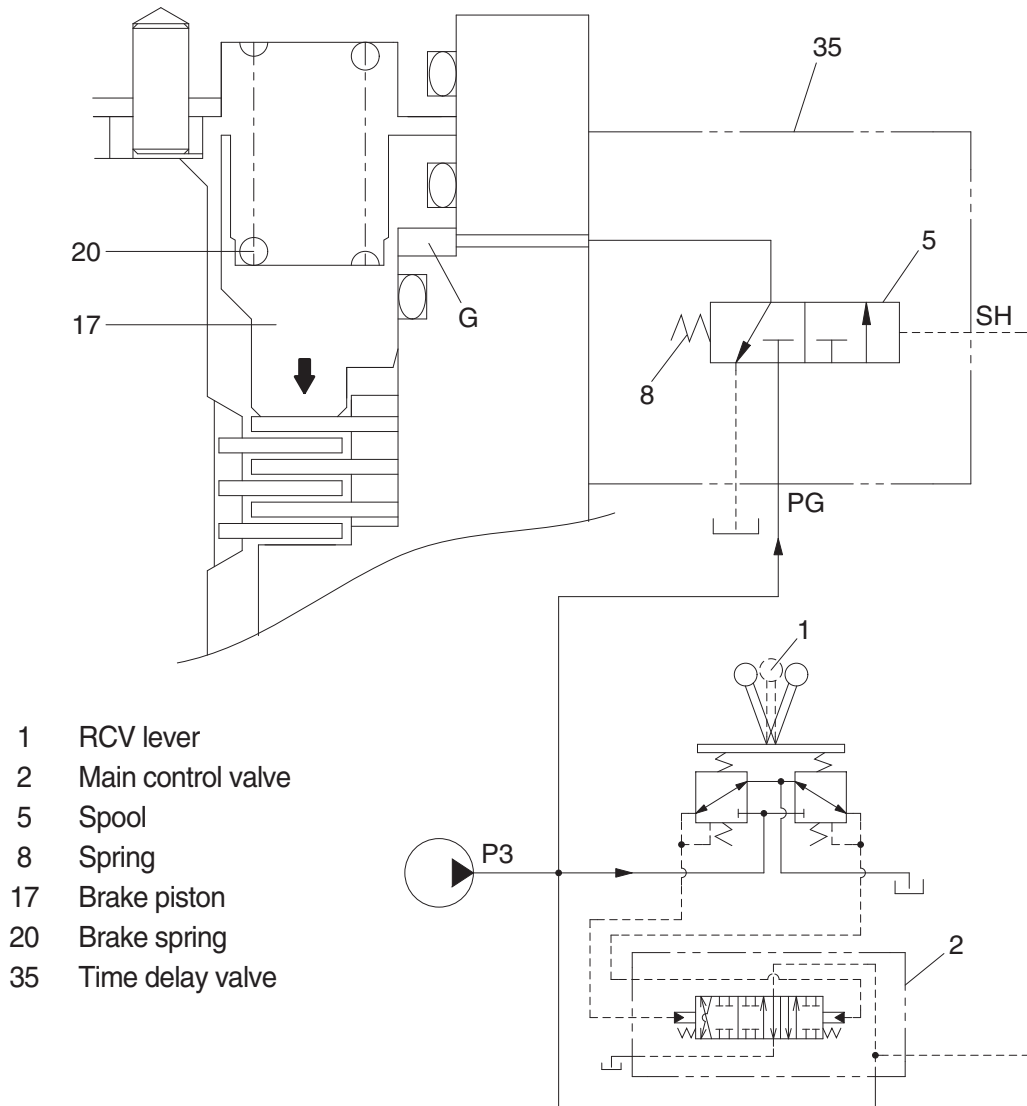

21092SM17

## GROUP 4 TRAVEL DEVICE

### 1. CONSTRUCTION

Travel device consists travel motor and gear box.

Travel motor includes brake valve, parking brake and high/low speed changeover mechanism.

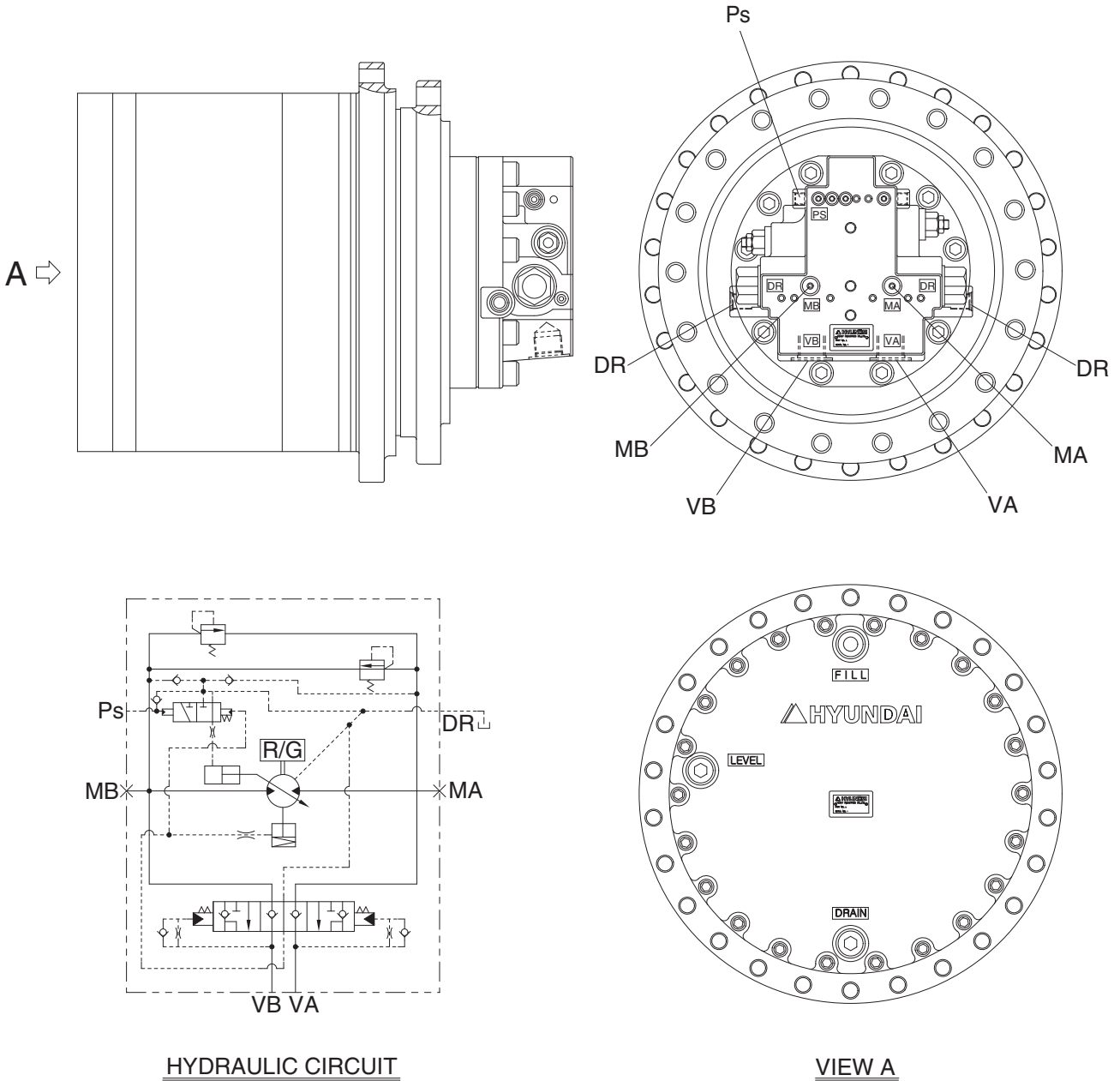

300L2TM01

Port	Port name	Port size
VA, VB	Valve port	PF 1
Ps	Pilot port	PF 1/4
DR	Drain port	PF 1/2
MA, MB	Gauge port	PF 1/4

## 2. SPECIFICATION

### 1) TRAVEL MOTOR

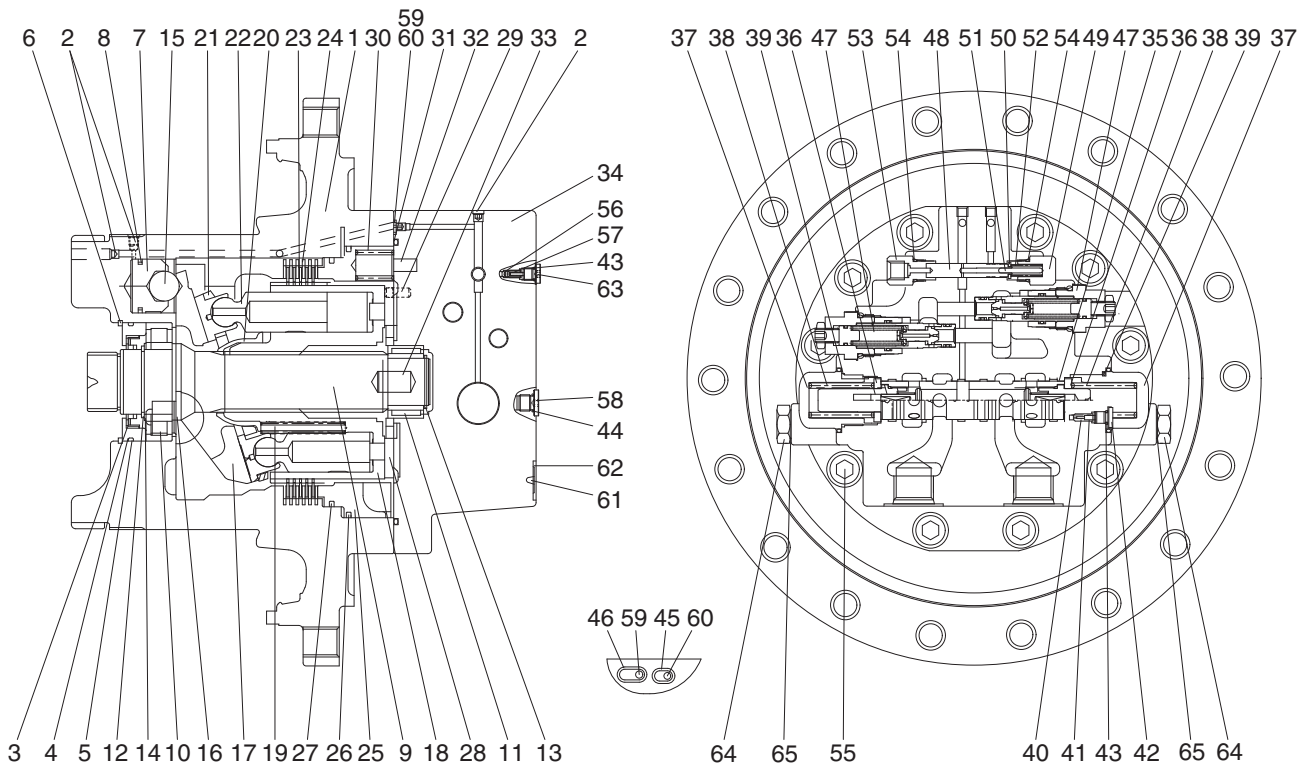

300L2TM02

1	Casing	23	Friction plate	45	O-ring
2	Plug	24	Separated plate	46	O-ring
3	Oil seal	25	Parking piston	47	Relief valve
4	Thrust block	26	D-ring	48	Spool
5	O-ring	27	D-ring	49	Plug
6	Snap ring	28	Valve plate	50	Spring seat
7	Piston	29	Parallel pin	51	Parallel pin
8	Piston seal	30	Spring	52	Spring
9	Shaft	31	O-ring	53	Connector
10	Cylinder roller bearing	32	Spring pin	54	O-ring
11	Needle bearing	33	Parallel pin	55	Hexagon socket head bolt
12	Snap ring	34	Rear cover	56	Check valve
13	Snap ring	35	Main spool assy	57	Spring
14	Thrust plate	36	Spring seat	58	Plug
15	Steel ball	37	Plug	59	Restrictor
16	Pivot	38	Spring	60	Restrictor
17	Swash plate	39	O-ring	61	Name plate
18	Cylinder block	40	Restrictor	62	Rivet
19	Spring	41	Spring	63	Plug
20	Ball guide	42	Plug	64	Plug
21	Retainer plate	43	O-ring	65	O-ring
22	Piston assy	44	O-ring		

## 2) TRAVEL REDUCTION GEAR

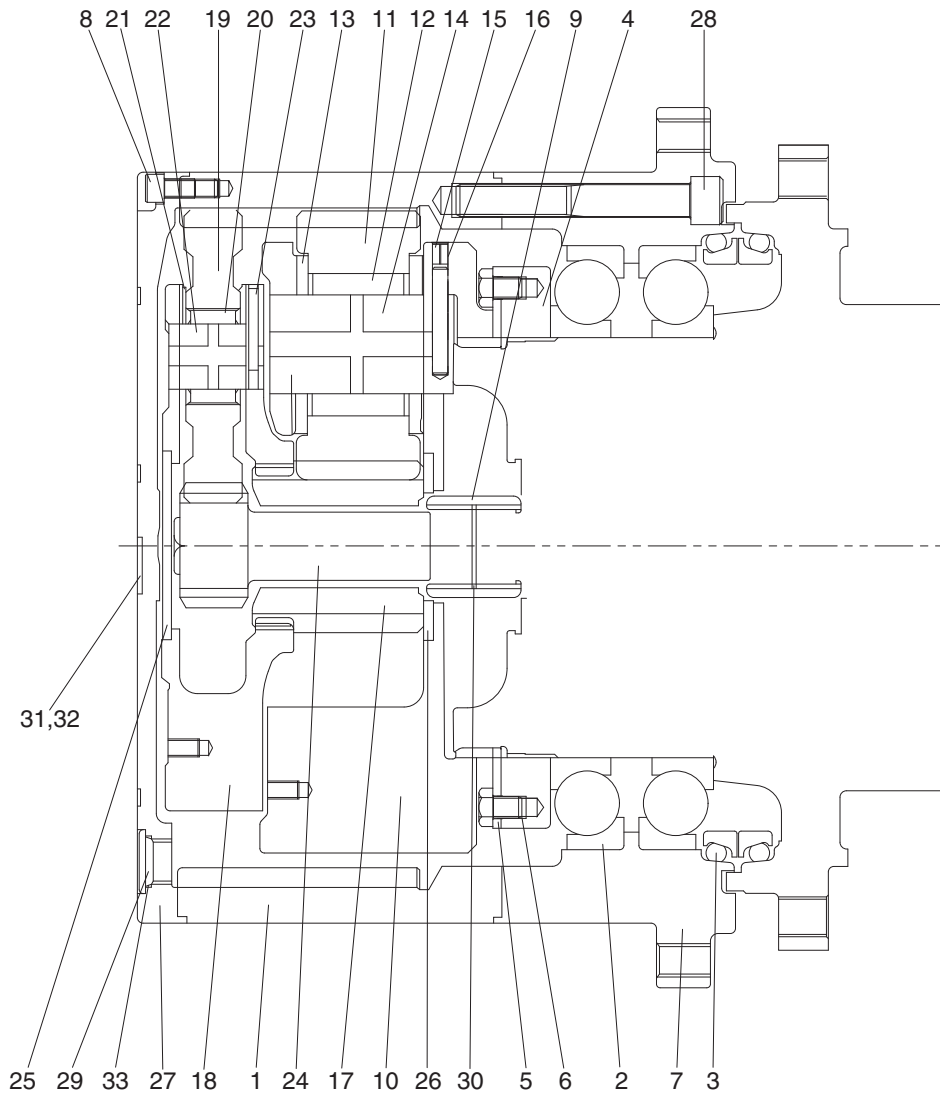

300L2TM03

1	Gear ring	12	Needle bearing 2	23	Spring pin 1
2	Ball bearing	13	Thrust washer 2	24	Sun gear 1
3	Floating seal assy	14	Carrier pin 2	25	Thrust plate
4	Nut ring	15	Spring pin 2	26	Thrust plate
5	Lock plate	16	Solid pin 2	27	Cover
6	Hexagon socket head bolt	17	Sun gear 2	28	Hexagon socket head bolt
7	Housing	18	Carrier 1	29	Plug
8	Hexagon socket head bolt	19	Planetary gear 1	30	Snap ring
9	Coupling	20	Needle bearing 1	31	Name plate
10	Carrier 2	21	Thrust washer 1	32	Rivet
11	Planetary gear 2	22	Carrier pin 1	33	O-ring

### 3. OPERATION

#### 1) MOTOR

High pressure oil delivered from hydraulic pump is led to inlet port that is provided in the brake valve portion and, through the rear cover (34) and valve plate (28), led to cylinder block (18).

The oil flow and direction of shaft rotation are indicated in table.

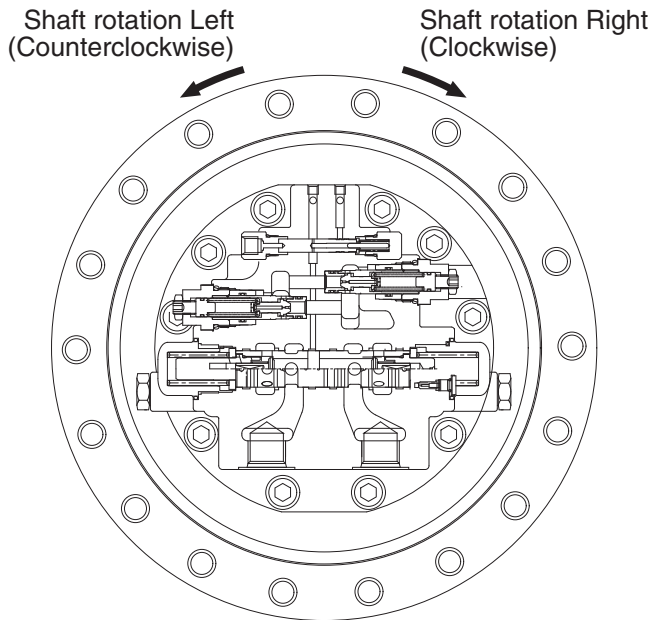

Inlet port	Outlet port	Direction of shaft rotation (viewing from rear cover)
VB	VA	Right (clockwise)
VA	VB	Left (counterclockwise)

300L2TM04

As shown in below figure, high pressure oil is supplied to the pistons which are on one side of the line Y-Y that connects upper and lower dead points and produces force F1.

$$F1 = P \times A \quad (P : \text{pressure, } A : \text{area of piston section})$$

The swash plate (17) with inclined angle of  $\alpha$  divides this force F1 into thrust force F2 and radial force F31-34.

This radial force is applied to axis Y-Y as turning force and generate drive torque of T.

$$T = r_1 \cdot F31 + r_2 \cdot F32 + r_3 \cdot F33 + r_4 \cdot F34$$

This drive torque is transmitted via cylinder block (18) to driving shaft (9).

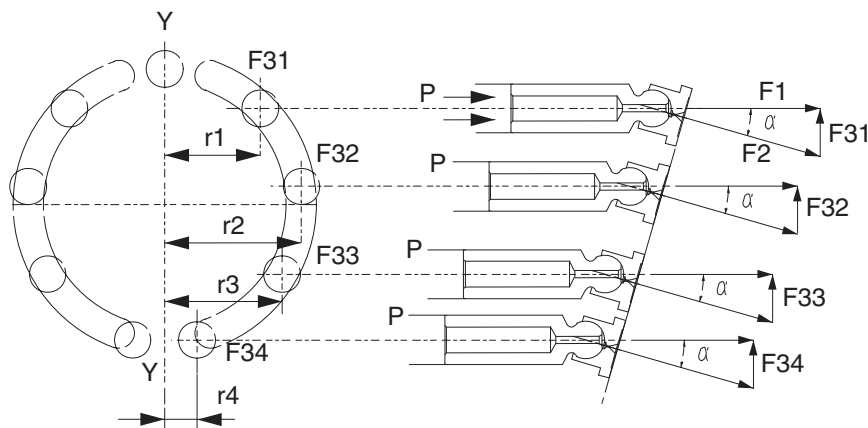

29092TM07

## 2) PARKING BRAKE

Parking brake is released when high pressure oil selected by the brake valve portion that is connected directly to the rear cover (34), is applied to the parking piston (25).

Otherwise the braking torque is always applied.

This braking torque is generated by the friction between the separated plates (24), inserted into the casing (1), and friction plates (23), coupled to cylinder block (18) by the outer splines.

When no pressure is activated on the parking piston (25), it is pushed by the brake springs (30) and it pushes friction plates (23) and separated plates (24) towards casing (1) and generates the friction force which brakes the rotation of cylinder block (18) and hence the shaft (9).

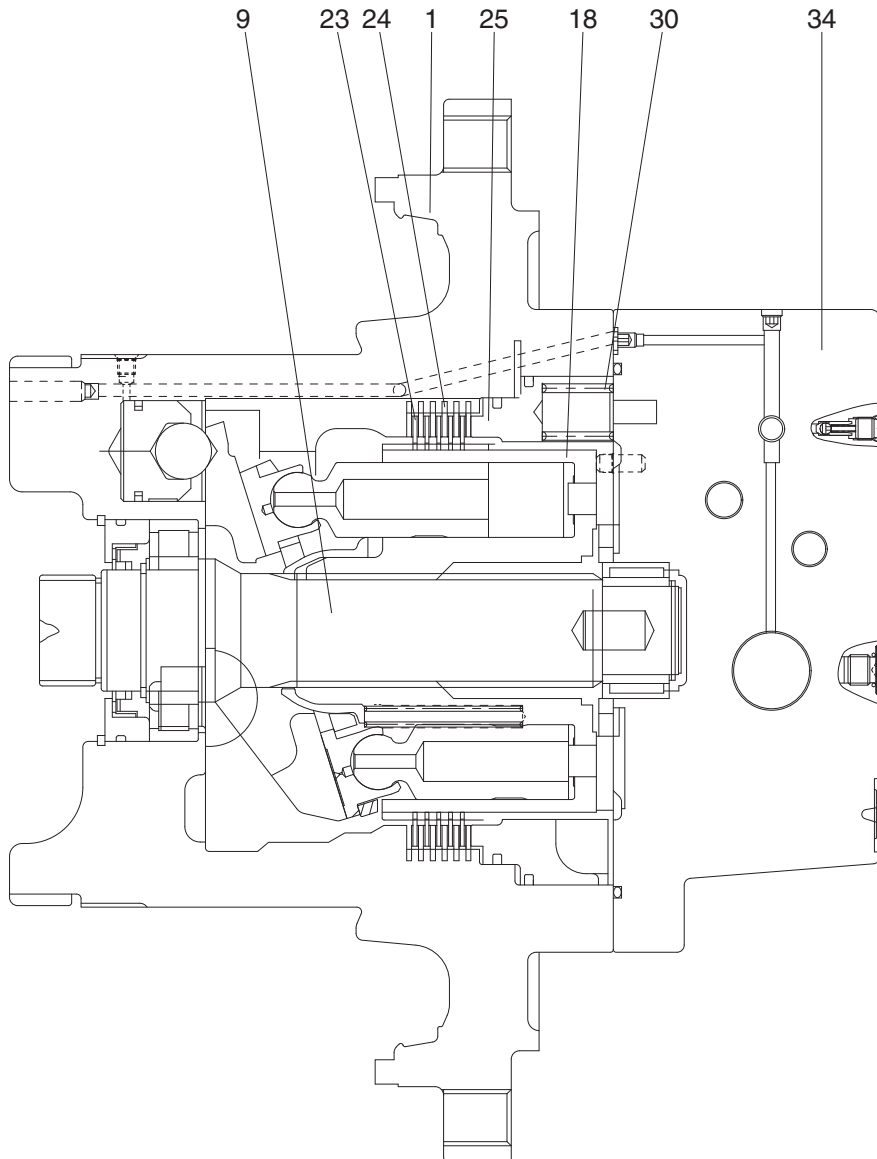

2609A2TM05

### 3) CAPACITY CONTROL MECHANISM

Figure typically shows the capacity control mechanism.

When high speed pilot line is charged with the pressure  $P_A$  that overcome the spring (52), the spring (52) is compressed and spool (48) shifts to the right to connect the port P and port C.

Then, the highest pressure is selected by the check valve (56) from inlet and outlet pressure of the motor and high speed pilot line pressure and pushes shifter piston (7). As a result, swash plate (17) turns around the line L which connect the two pivots (16) as shown by dotted lines. The turn stops at the stopper (1-1) of casing and swash plate (17) keeps the position.

In this case, the piston stroke become shorter and motor capacity become smaller and motor rotates faster, around 1.60 times, by the same volume of oil.

When no pressure is in the high speed pilot line  $P_A$ , spool (35) is pushed back by the spring (52) and pressure that pressed the shifter piston (7) is released to the hydraulic tank through restrictor (60).

Here, nine pistons are there and they equally spaced on the swash plate (17). The force that summed up those of pistons comes to almost the center of the swash plate (17) as shown. Since the pivots (16) are off-set by S from the center, the rotating force of product S and the force moves swash plate (17) to the former position and the speed returns to low.

When the power demand exceeds the engine power, such as in steep slope climbing or turning at high speed mode, the system step down to the low speed automatically. The mechanism is that: pump pressure is led to the port  $P_B$  and this pressure activate on pin (51). When the pressure at  $P_B$  exceeds predetermined value, spool (48) returns to the left by the counter-pressure against pin (51) and the pressure on the shifter piston (7) through port C is released to the tank and the motor comes to low speed.

When  $P_B$  goes down, the spool (48) moves to the right and the speed become high.

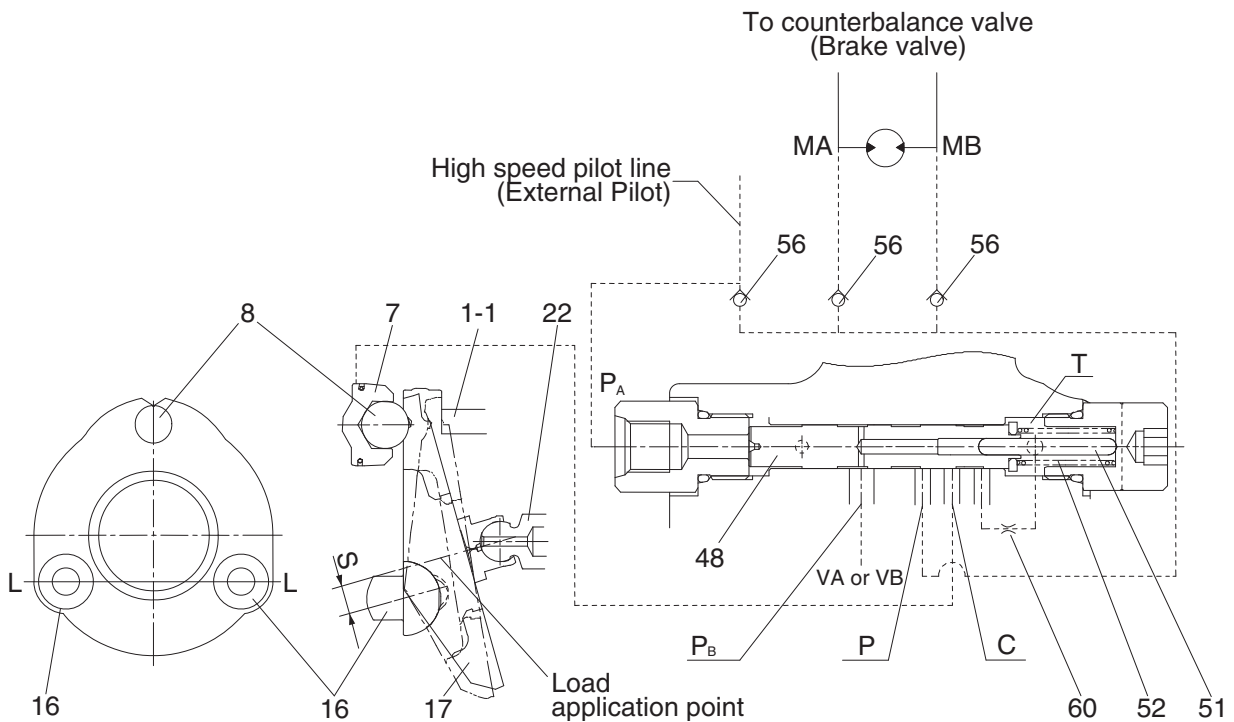

2609A2TM06

#### 4) OVERLOAD RELIEF VALVE

##### (1) Structure

This valve is screwed in the motor rear cover (34) and consists of : plug (47-1) that is screwed and fixed in the rear cover (34), poppet (47-10) and supports the poppet seat (47-11), spring (47-4) that is operating relief valve setting pressure and supports the spring seat (47-5), that is inserted in the sleeve (47-6), screw (47-14) that is adjust the spring force, nut (47-15) that fix screw (47-14), piston (47-7) that reduce the shock.

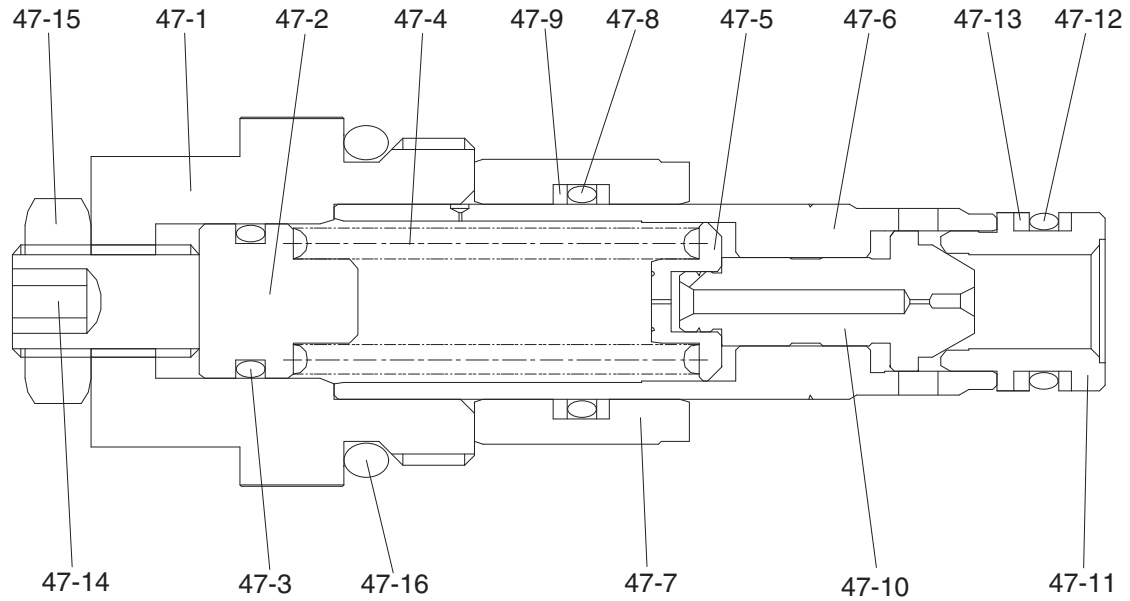

2609A2TM07

47-1 Plug	47-7 Piston	47-12 O-ring
47-2 Guide	47-8 O-ring	47-13 Back-up ring
47-3 O-ring	47-9 Back-up ring	47-14 Socket screw
47-4 Spring	47-10 Poppet	47-15 Hexagon nut
47-5 Spring seat	47-11 Poppet seat	47-16 O-ring
47-6 Sleeve		



## (2) Operation

Two pieces of overload valves are located at cross-over position in the counterbalance circuit of brake valve and have the following functions:

- ① When hydraulic motor starts, keep the driving pressure below predetermined value and while accelerating, bypasses surplus oil to return line.
- ② When stopping the motor, keep the brake pressure, that develops on the outlet side of motor, under the predetermined value to stop the inertial force.
- ③ To accelerate sharply while starting, and to mitigate the braking shock while stopping. For these purposes, the developed pressure is kept comparatively low for a short period, then keep the line pressure as normal value. While the pressure is low, meshing of reduction gears, crawler and sprocket etc. can be smoothly done and the shock are absorbed.

When starting, "A" port pressure of overload valve increases, this pressure is applied to the effective diameter of poppet (47-10) which seats on the poppet seat (47-11) and, at the same time, is delivered, via small hole, to the spring seat (47-5) located inside the sleeve (47-6) and the seat bore pressure increases up to "A" port pressure. The poppet (47-10) opposes to spring (47-4) by the force of the pressure exerted on the area difference between poppet seat's effective diameter and spring seat bore and keep the predetermined pressure.

When hydraulically braking, the piston (47-7) is at the left position by the driving pressure, and when "A" port pressure increases, the pressure is applied also to the piston (47-7) through the small hole in the poppet (47-10) and piston (47-7) moves rightward until it touches the stopper in rear cover. In this while, the poppet (47-10) maintains "A" port pressure at comparatively low against the spring (47-4) force and exhaust oil to "B" port side. After the piston reached to the plug, the valve acts the same as at starting.

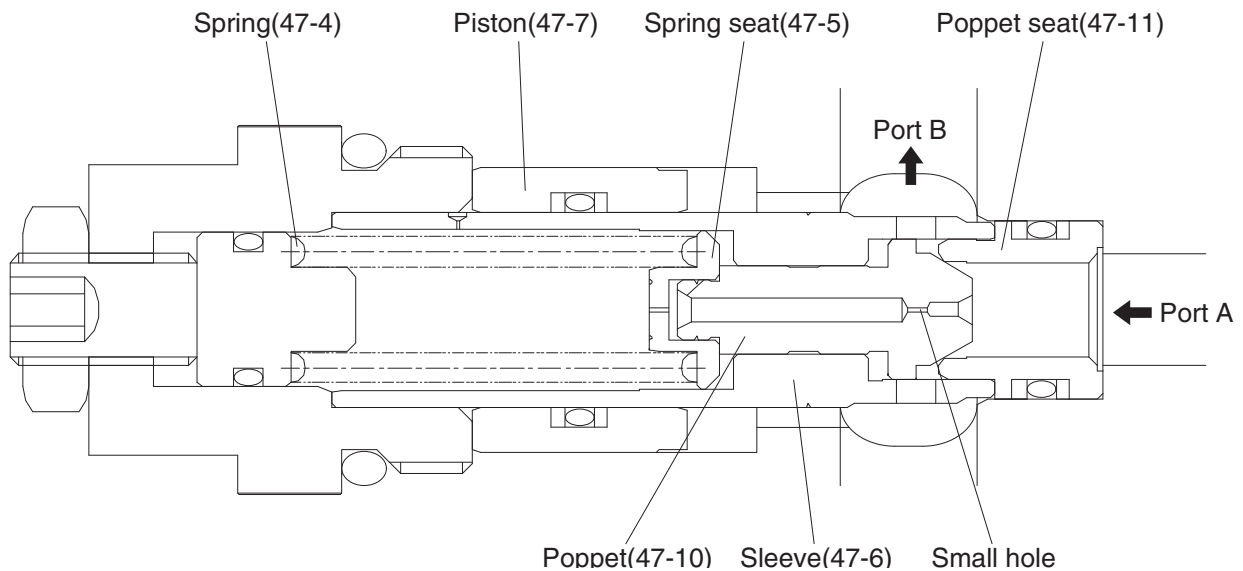

2609A2TM08

## 5) BRAKE VALVE

### (1) Structure

The brake valve portion mainly consists of the following parts:

#### ① Spool

By shifting the spool (35), the discharged oil from hydraulic motor is automatically shut off or restricted according to the condition and give the effect of holding, accelerating, stopping and counterbalance operations.

(See page 2-74, (2) Operation)

#### ② Check valve (built in the spool)

This valve is located in the oil supplying passage to hydraulic motor, and at the same time functions to lock oil displacement. Therefore, this valve serves as not only a suction valve but also a holding valve for hydraulic motor.

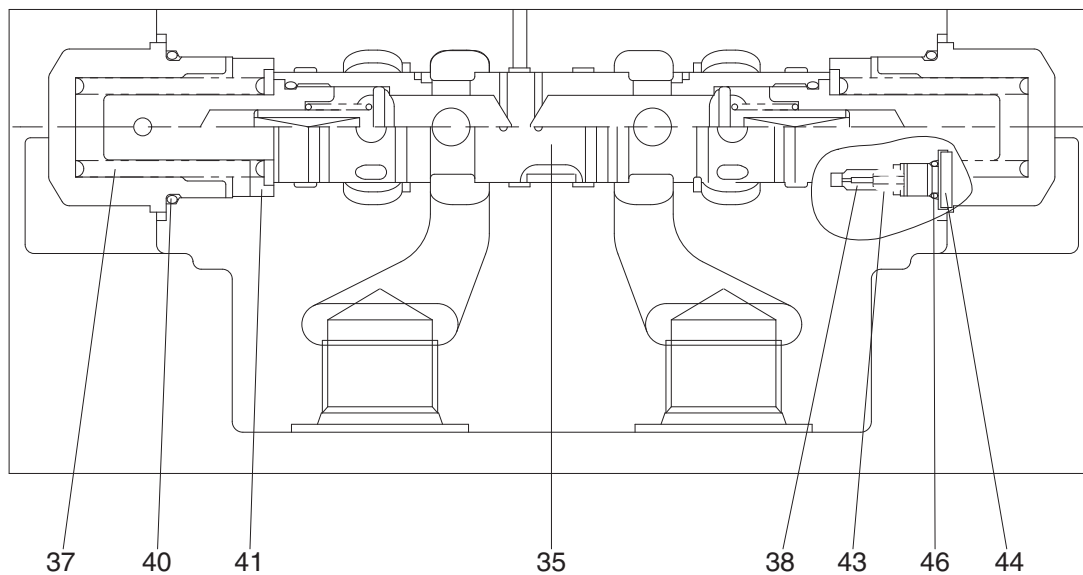

2609A2TM09

35	Main spool	40	O-ring	44	O-ring
37	Spring	41	Spring seat	46	Plug
38	Restrictor	43	Restrictor spring		

## (2) Operation

### ① Holding operation

When the control valve is at neutral position, VA and VB ports are connected to the tank, and the spring (38) located on both spool ends holds the spool (35) at central position.

Therefore, the passages from VA to MA and VB to MB are closed, which result in closing MA and MB ports connected to hydraulic motor.

Since the passage to parking brake is connected to the tank line, the brake cylinder pressure is equal to the tank pressure and the brake is applied by the springs. Thus, the rotation of the motor is mechanically prevented.

If external torque is exerted on the motor shaft, the motor would not rotate as usual by this negative parking brake.

In case the brake should be released for some reason, pressure is built on MA or MB port. But, due to oil leakage inside hydraulic motor or so, high-pressure oil escapes from the closed circuit and motor rotates a bit. So, the cavitation tends to occur in the lower pressure side of the closed circuit. Then, the check valve, built in the spool (35), operates to avoid the cavitation and opens the passage from VA to MA or from VB to MB. Then the oil equivalent to the leakage is sucked from the tank line to the closed circuit.

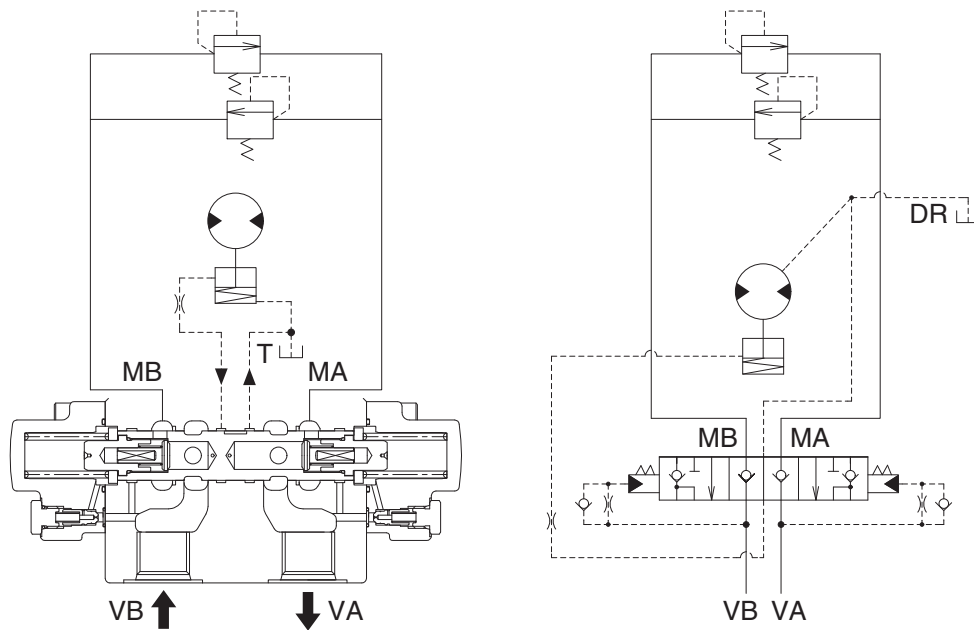

25092TM29

## ② Accelerating operation

When VA and VB ports are connected respectively to pump and tank by operating the control valve, hydraulic oil from pump is forwarded through VA port to push open the check valve provided inside spool (35), and oil flows to motor via MA port to rotate the motor.

Therefore, the pressure increases and negative brake is released by the pressure supplied from pump. At the same time, the pressure of pilot chamber increases to push and move the spool (35) leftwards, overcoming the spring (38) force. Thus, the return line from MB to VB opens to rotate the motor.

In case inertia load is too big to start rotation, accelerating pressure reaches the set pressure of relief valve and high pressure oil is being relieved while the motor gains the rotational speed.

As the rotational speed goes up, the relieved volume decreases, and finally the motor rotates at a fixed speed.

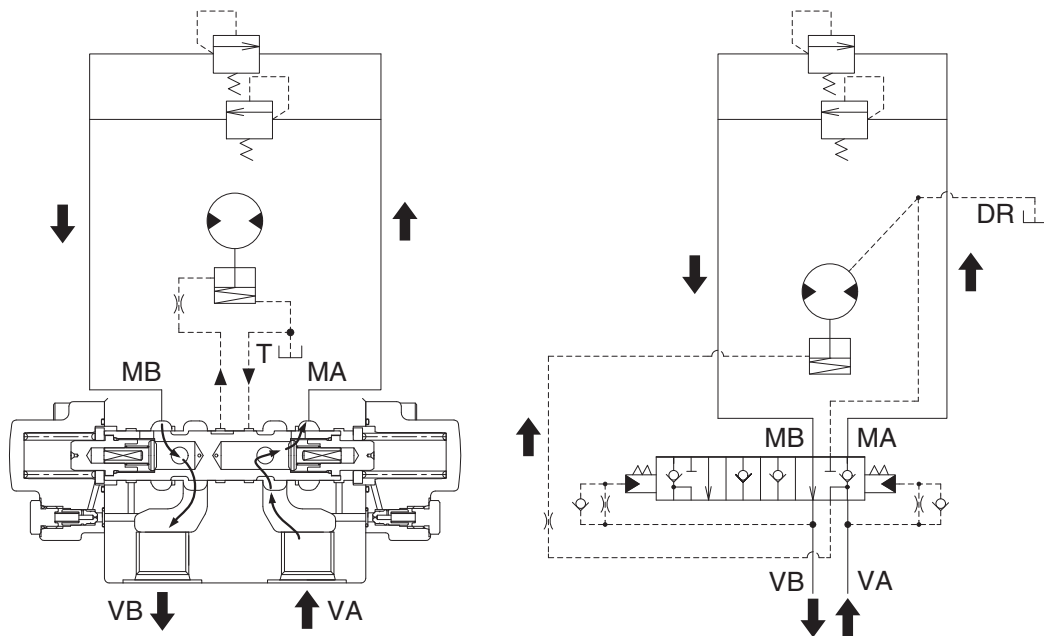

25092TM30

### ③ Stopping operation

Returning the control valve to neutral position while running the motor, the oil supply is cut off and VA and VB ports are connected to the tank line. Then the pressure of the pilot chamber located on both spool ends become equal, and the spool (35) returns to the neutral position by spring (38) force. Thus, the passage from MA to VA is closed.

Owing to the inertia force of the load, the hydraulic motor tends to continue the rotation. Here, the motor functions as a pump and forwards the oil to MB port but the passage is blocked and MB port pressure increases. Then the relief valve opens to relieve the pressure and rotational speed decelerates and at last the motor stops.

Negative brake release pressure is gradually lowered due to the restrictor and finally the brake works and the motor is mechanically stopped.

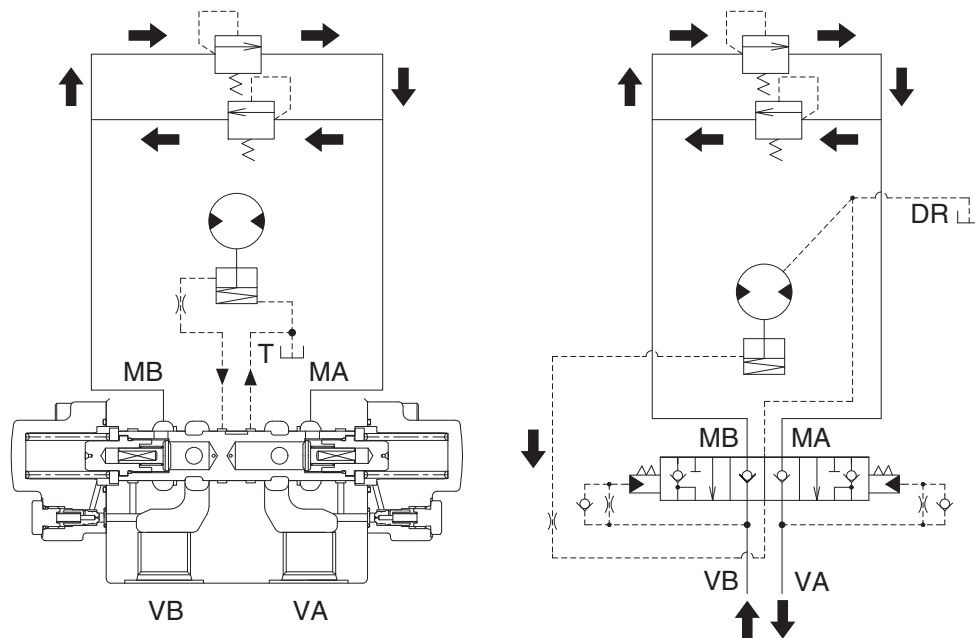

25092TM31

#### ④ Counterbalance operation

Counterbalance operation is required to decelerate slowly the hydraulic motor while absorbing inertia force.

In case the hydraulic oil is gradually decreased from pump to VB port, the drive shaft of hydraulic motor tends to rotate faster than that matched to the volume of oil supply.

Consequently, the pilot chamber pressure on MB to VB side decreases and the spring (38) force moves the spool (35) leftwards towards neutral position.

Therefore, the area of passage from MA to VA becomes smaller and the pressure on MA side rises due to increased resistance in the passage and the motor receives hydraulic braking effect.

If the motor rotates slower than that matched to the volume of supplied oil, the pilot chamber pressure on VB port increases, and spool (35) moves rightwards to enlarge the area of passage from MA to VA. Therefore the braking effect becomes smaller and the rotational speed of motor is controlled to correspond to the volume of supplied oil.

In order to give stable counterbalance operation, the restrictors (40) are set in the pilot chamber to damp the spool (35) movement.

The parking brake is released during pressure adjusting action of the spool (35).

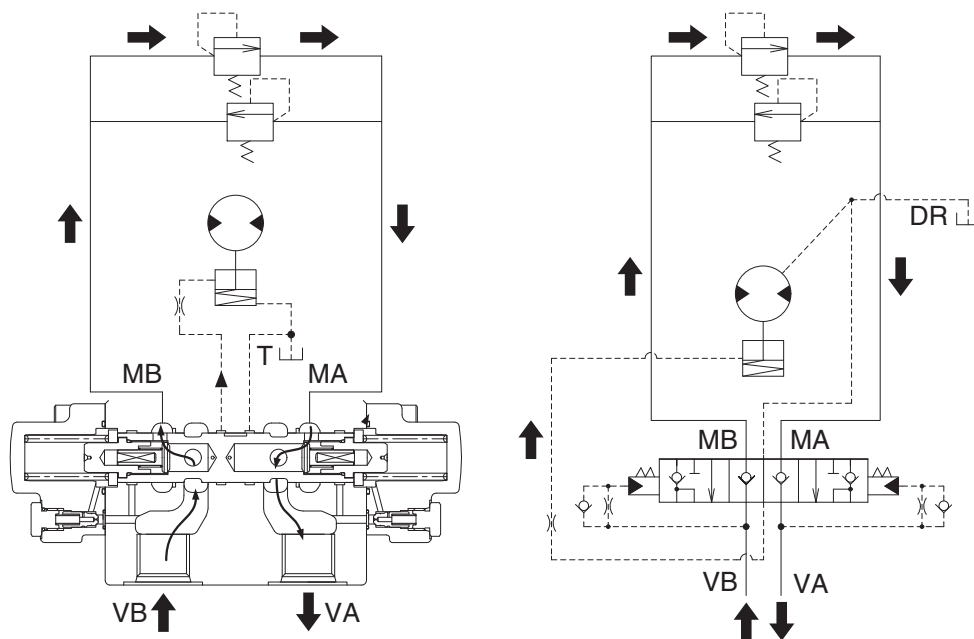

25092TM32

## 6) REDUCTION GEAR

Reduction unit slows down the rotating speed of motor and converts motor torque to strong rotating force.

This reduction unit utilizes two stages, planetary reduction system.

Planetary reduction system consists of sun gear, planetary gears, (planetary) carriers, and ring gear.

When the sun gear (s) is driven through input shaft, planetary pinions (b), rotating on their center, also move, meshing with fixed ring gear (a), around sun gear (s).

This movement is transferred to carrier (k) and deliver the torque.

This mechanism is called planetary gear mechanism.

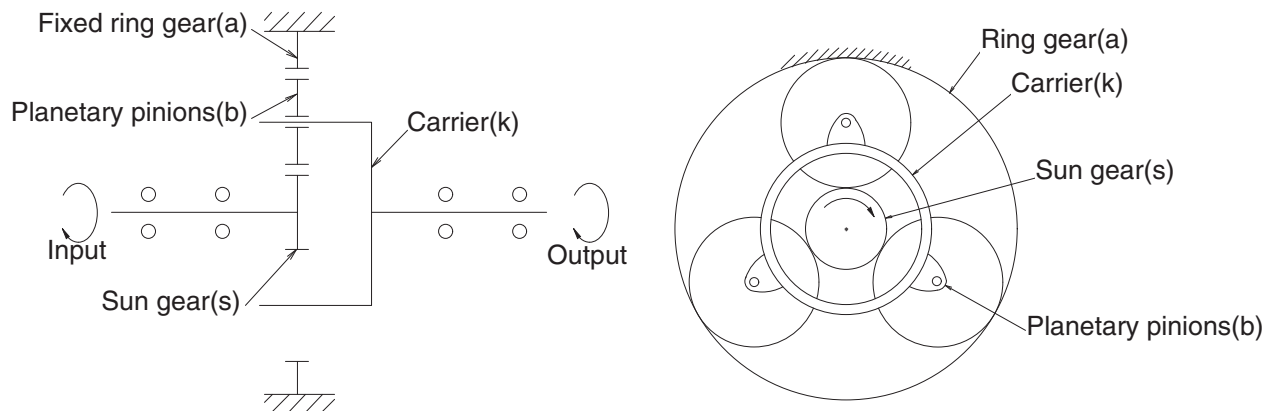

29072TM10

29072TM11

When the sun gear **S1** is driven by input shaft, planetary action occurs among gears **S1**, **a** and **b** and revolution of gear **b** transfers the rotation of carrier **K1** to second sun gear **S2**, and also evokes planetary action between gear **S2**, **a** and **d**.

This time, because carrier **K2** is fixed to frame, gear **d** drives ring gear **a** and then ring gear **a** rotates to drive sprocket.

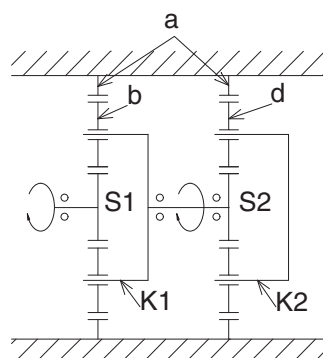

29072TM12

## GROUP 5 RCV LEVER

### 1. STRUCTURE

The casing has the oil inlet port P (primary pressure) and the oil outlet port T (tank). In addition the secondary pressure is taken out through ports 1, 2, 3 and 4 provided at the bottom face.

※ Refer to the parts manual for the types of the RCV lever.

#### 1) TYPE L1, L3, L5

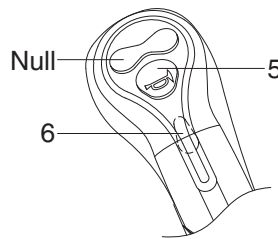
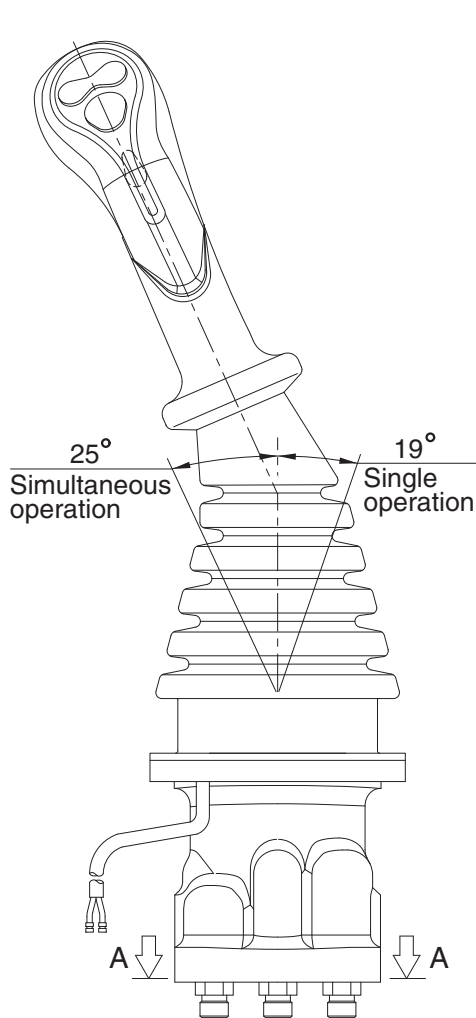

TYPE L1, L3

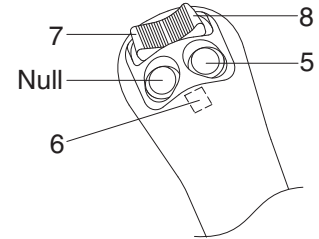

TYPE L5

#### Switches

Type	No.	LH	RH
L1, L3	5	One touch decel	Horn
	6	Power boost	Breaker
L5	5	One touch decel	Horn
	6	Power boost	Null
	7	CCW rotation	Close
	8	CW rotation	Open

※ Number 7 and 8 : Option attachment

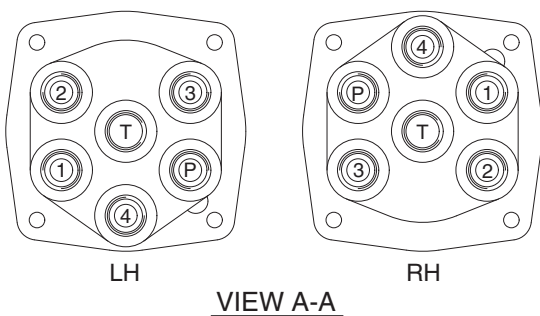
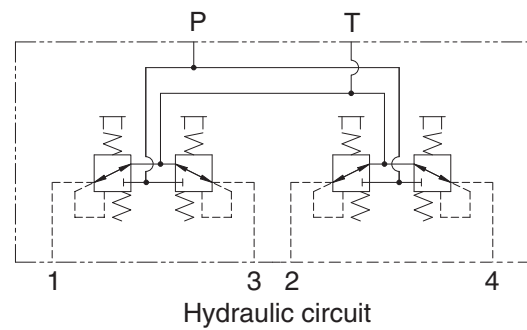

#### Pilot ports

Port	LH	RH	Port size
P	Pilot oil inlet port	Pilot oil inlet port	PF 3/8
T	Pilot oil return port	Pilot oil return port	
1	Left swing port	Bucket out port	
2	Arm out port	Boom up port	
3	Right swing port	Bucket in port	
4	Arm in port	Boom down port	

300L2RL01



## 2) TYPE L2, L4, L6

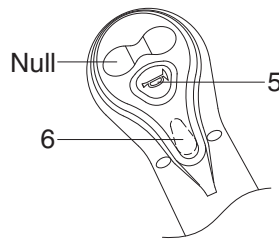
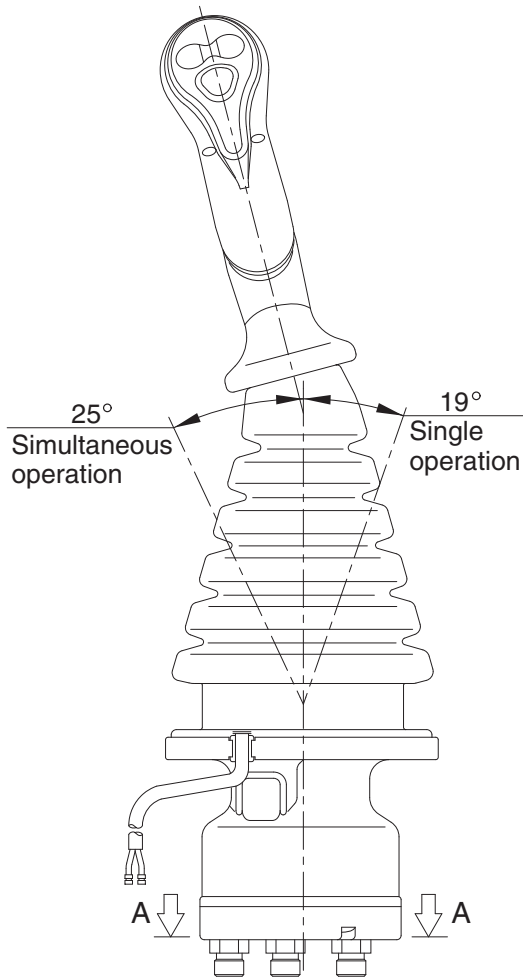

TYPE L2, L4

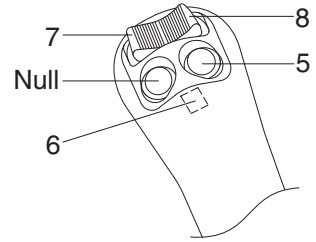

TYPE L6

### Switches

Type	No.	LH	RH
L2, L4	5	One touch decel	Horn
	6	Power boost	Breaker
L6	5	One touch decel	Horn
	6	Power boost	Null
	7	CCW rotation	Close
	8	CW rotation	Open

※ Number 7 and 8 : Option attachment

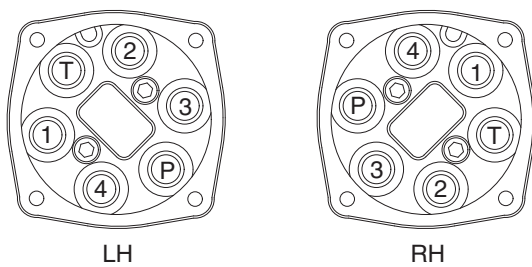
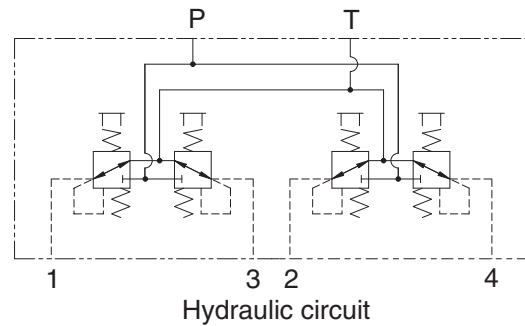

VIEW A-A

### Pilot ports

Port	LH	RH	Port size
P	Pilot oil inlet port	Pilot oil inlet port	PF 3/8
T	Pilot oil return port	Pilot oil return port	
1	Left swing port	Bucket out port	
2	Arm out port	Boom up port	
3	Right swing port	Bucket in port	
4	Arm in port	Boom down port	

300L2RL05

### 3) CROSS SECTION

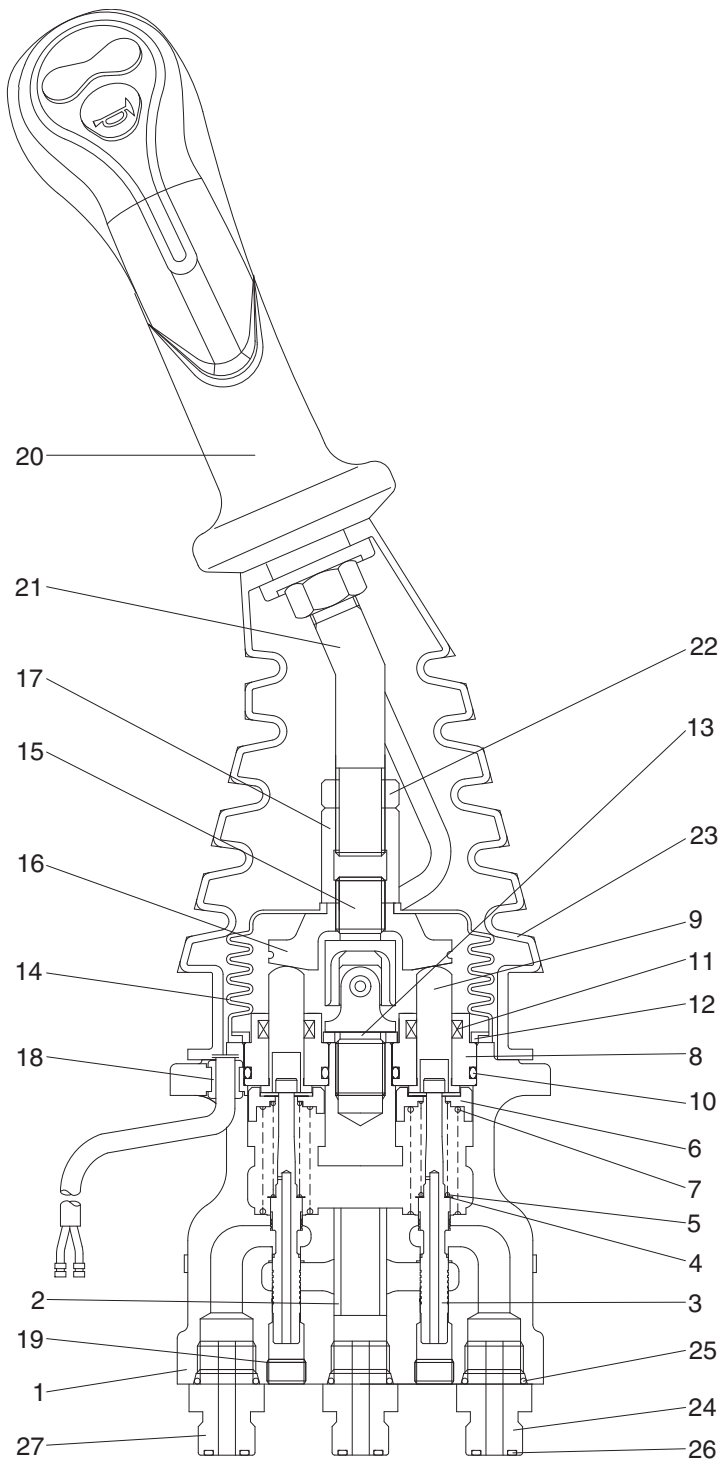

- 1 Case
- 2 Bushing
- 3 Spool
- 4 Shim
- 5 Spring
- 6 Spring seat
- 7 Spring
- 8 Plug
- 9 Push rod
- 10 O-ring
- 11 Rod seal
- 12 Plate
- 13 Spacer
- 14 Boot
- 15 Joint assembly
- 16 Swash plate
- 17 Adjusting nut
- 18 Bushing
- 19 Plug
- 20 Handle assembly
- 21 Handle bar
- 22 Nut
- 23 Boot
- 24 Last guard filter
- 25 O-ring
- 26 O-ring
- 27 Connector

300L2RL06

#### Item numbers are based on the type L1.

The construction of the pilot valve is shown in the attached cross section drawing. The casing has vertical holes in which reducing valves are assembled.

The pressure reducing section is composed of the spool (3), spring (5) for setting secondary pressure, return spring (7), spring seat (6) and shim (4). The spring for setting the secondary pressure has been generally so preset that the secondary pressure is 5 to 20.5 kgf/cm<sup>2</sup> (depending on the type). The spool is pushed against the push rod (9) by the return spring.

When the push rod is pushed down by tilting the handle, the spring seat comes down simultaneously and changes setting of the secondary pressure spring.

## 2. FUNCTIONS

### 1) FUNDAMENTAL FUNCTIONS

The pilot valve is a valve that controls the spool stroke, direction, etc of a main control valve. This function is carried out by providing the spring at one end of the main control valve spool and applying the output pressure (secondary pressure) of the pilot valve to the other end.

For this function to be carried out satisfactorily, the pilot valve is composed of the following elements.

- (1) Inlet port (P) where oil is supplied from hydraulic pump.
- (2) Output ports (1, 2, 3 & 4) to apply pressure supplied from inlet port to ends of control valve spools.
- (3) Tank port (T) necessary to control the above output pressure.
- (4) Spool to connect output port to inlet port or tank port.
- (5) Mechanical means to control output pressure, including springs that work on the above spools.

### 2) FUNCTIONS OF MAJOR SECTIONS

**Item numbers are based on the type L1.**

The functions of the spool (3) are to receive the supply oil pressure from the hydraulic pump at its port P, and to change over oil paths to determine whether the pressure oil of port P is led to output ports 1, 2, 3 & 4 or the output port pressure oil to tank port T.

The spring (5) works on this spool to determine the output pressure.

The change the deflection of this spring, the push rod (9) is inserted and can slide in the plug (8).

For the purpose of changing the displacement of the push rod through the swash plate (16) and adjusting nut (17) are provided the handle assy (20) that can be tilted in any direction around the fulcrum of the universal joint (15) center.

The spring (7) works on the case (1) and spring seat (6) and tries to return the push rod (9) to the zero-displacement position irrespective of the output pressure, securing its resetting to the center position.

This also has the effect of a reaction spring to give appropriate control feeling to the operator.

### 3) OPERATION

The operation of the pilot valve will be described on the basis of the hydraulic circuit diagram shown below and the attached operation explanation drawing.

The diagram shown below is the typical application example of the pilot valve.

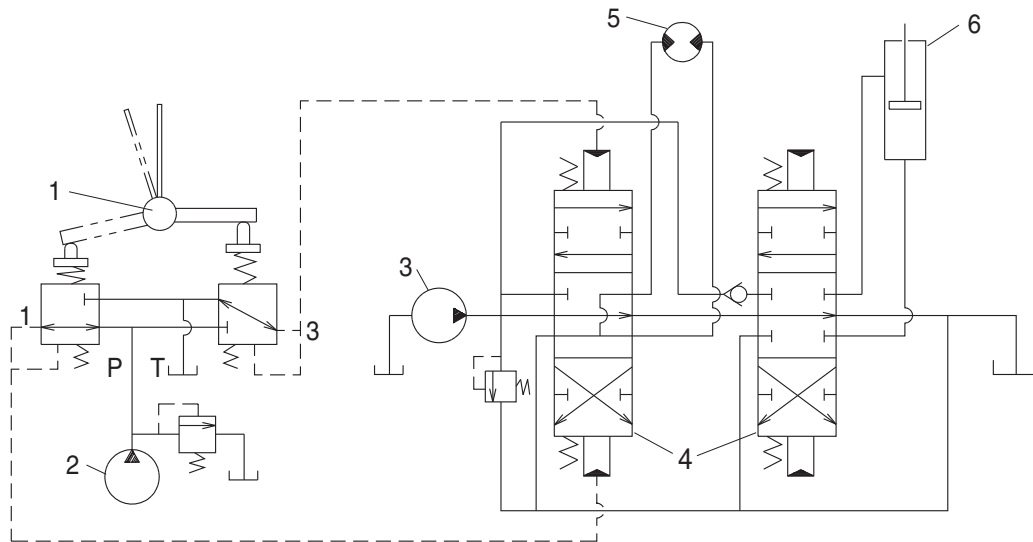

2-70

- 1 Pilot valve
- 2 Pilot pump

- 3 Main pump
- 4 Main control valve

- 5 Hydraulic motor
- 6 Hydraulic cylinder

(1) Case where handle is in neutral position

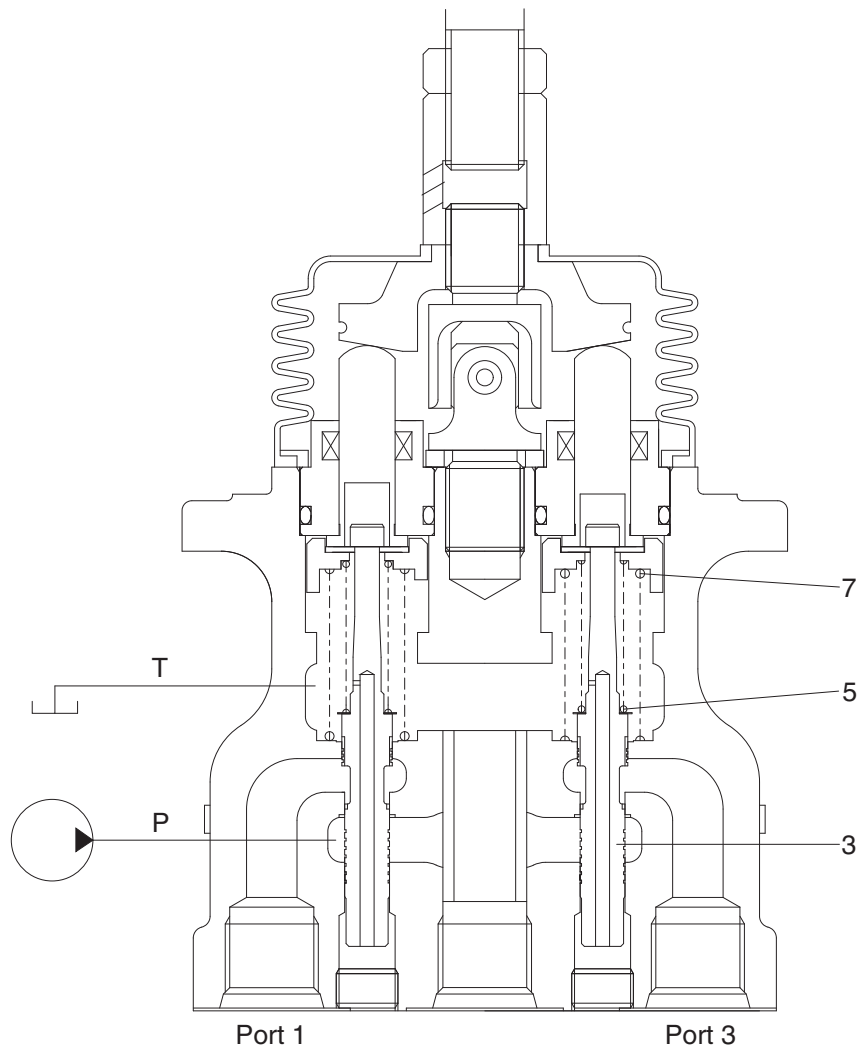

300L2RL03

The force of the spring (5) that determines the output pressure of the pilot valve is not applied to the spool (3). Therefore, the spool is pushed up by the spring (7) to the position of port (1, 3) in the operation explanation drawing. Then, since the output port is connected to tank port T only, the output port pressure becomes equal to tank pressure.

**(2) Case where handle is tilted**

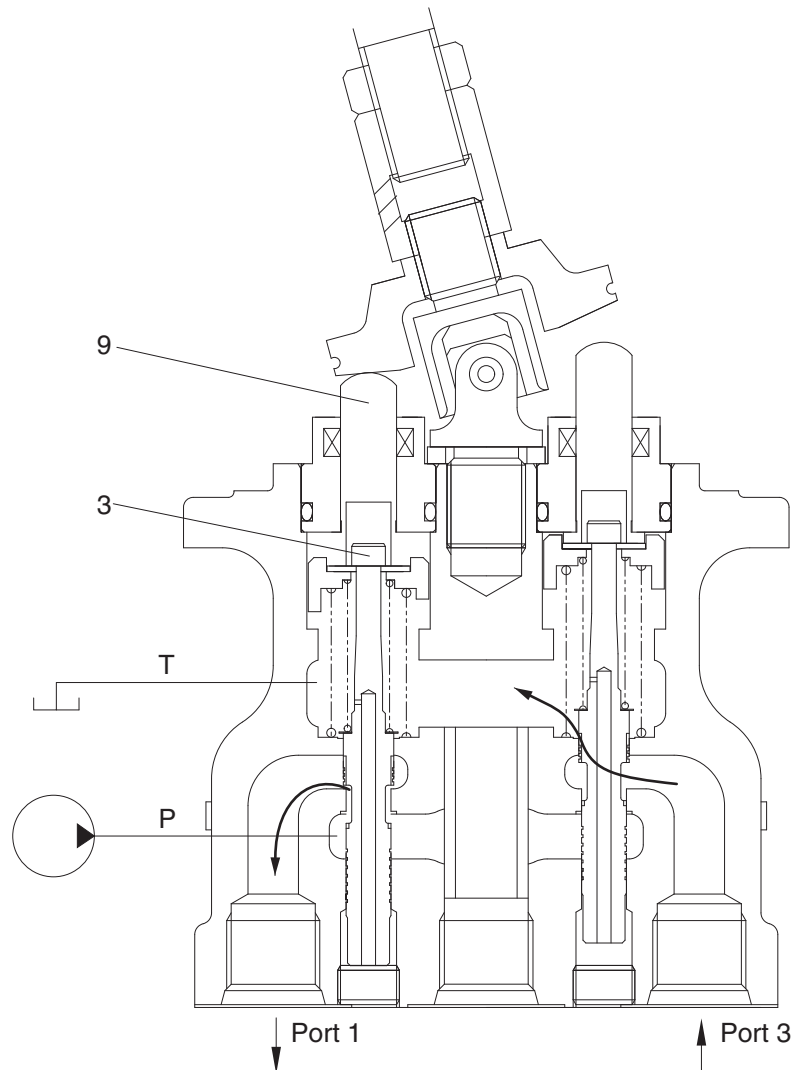

300L2RL04

When the push rod (9) is stroked, the spool (3) moves downwards.

Then port P is connected with port (1) and the oil supplied from the pilot pump flows through port (1) to generate the pressure.

When the pressure at port (1) increases to the value corresponding to the spring force set by tilting the handle, the hydraulic pressure force balances with the spring force. If the pressure at port (1) increases higher than the set pressure, port P is disconnected from port (1) and port T is connected with port (1). If it decreases lower than the set pressure, port P is connected with port (1) and port T is disconnected from port 1.

In this manner the secondary pressure is kept at the constant value.

Besides, in some type, when the handle is tilted more than a certain angle, the upper end of the spool contacts with the inside bottom of the push rod and the output pressure is left to be connected with port P.

## GROUP 6 RCV PEDAL

### 1. STRUCTURE

The casing (spacer) has the oil inlet port P (primary pressure), and the oil outlet port T (tank). In addition the secondary pressure is taken out through ports 1, 2, 3 and 4 provided at the bottom face.

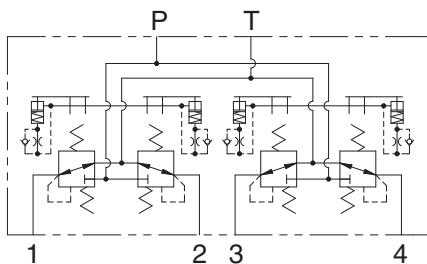
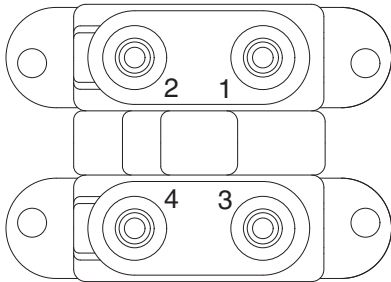
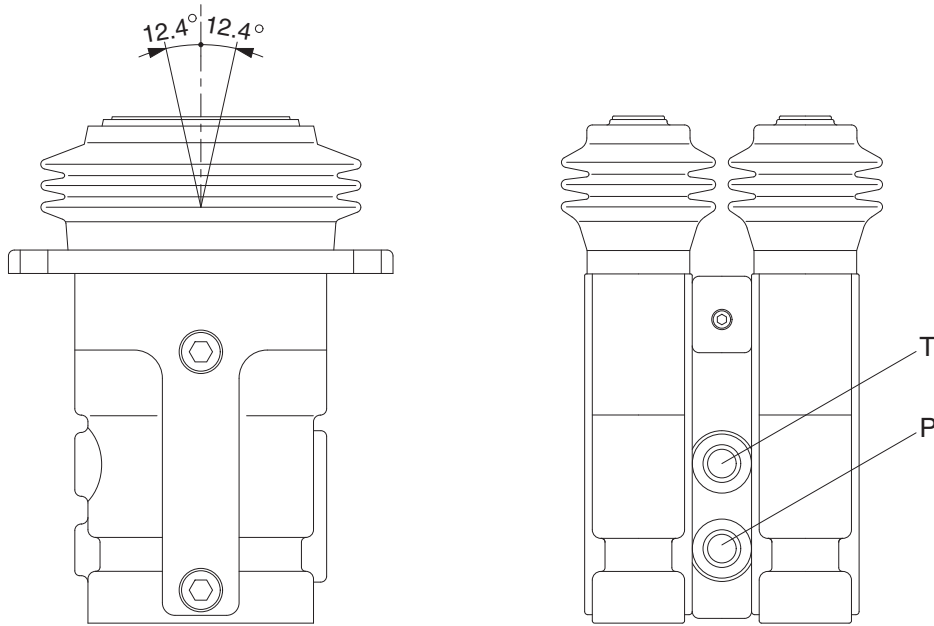

Hydraulic circuit

Port	Port	Port size
P	Pilot oil inlet port	PF 1/4
T	Pilot oil return port	
1	Travel (LH, Forward)	
2	Travel (LH, Backward)	
3	Travel (RH, Forward)	
4	Travel (RH, Backward)	

21092RP01

## CROSS SECTION

The construction of the RCV pedal is shown in the below drawing. The casing has vertical holes in which reducing valves are assembled.

The pressure reducing section is composed of the spool (8), spring (6) for setting secondary pressure, return spring (10), stopper (9), and spring seat (7). The spring for setting the secondary pressure has been generally so preset that the secondary pressure is 5 to 19 kgf/cm<sup>2</sup> (depending on the type). The spool is pushed against the push rod (14) by the return spring.

When the push rod is pushed down by tilting pedal, the spring seat comes down simultaneously and changes setting of the secondary pressure spring.

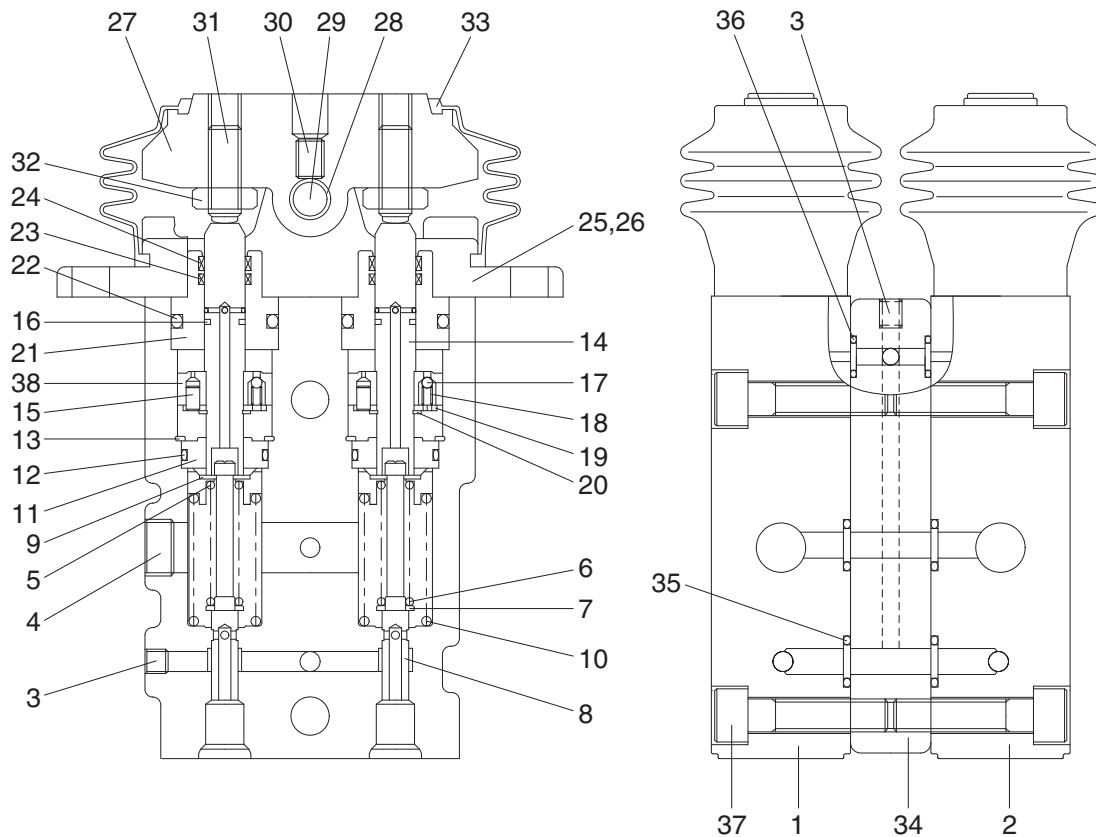

21092RP02

1	Body(1)	14	Push rod	27	Cam
2	Body(2)	15	Spring pin	28	Bushing
3	Plug	16	Seal	29	Cam shaft
4	Plug	17	Steel ball	30	Set screw
5	Spring seat	18	Spring	31	Set screw
6	Spring	19	Plate	32	Nut
7	Spring seat	20	Snap ring	33	Bellows
8	Spool	21	Plug	34	Space
9	Stopper	22	O-ring	35	O-ring
10	Spring	23	Rod seal	36	O-ring
11	Rod guide	24	Dust seal	37	Socket bolt
12	O-ring	25	Cover	38	Piston
13	Snap ring	26	Socket bolt		



## 2. FUNCTION

### 1) FUNDAMENTAL FUNCTIONS

The pilot valve is a valve controls the spool stroke, direction, etc of a main control valve. This function is carried out by providing the spring at one end of the main control valve spool and applying the output pressure (secondary pressure) of the pilot valve to the other end.

For this function to be carried out satisfactorily, the pilot valve is composed of the following elements.

- (1) Inlet port (P) where oil is supplied from hydraulic pump.
- (2) Output port (1, 2, 3 & 4) to apply pressure supplied from inlet port to ends of control valve spools.
- (3) Tank port (T) necessary to control the above output pressure.
- (4) Spool to connect output port to inlet port tank port.
- (5) Mechanical means to control output pressure, including springs that work on the above spools.

### 2) FUNCTIONS OF MAJOR SECTIONS

The functions of the spool (8) are to receive the supply oil pressure from the hydraulic pump at its port P, and to change over oil paths to determine whether the pressure oil of port P is led to output ports 1, 2, 3 & 4 or the output spool to determine the output pressure.

The spring (6) works on this spool to determine the output pressure.

The change the deflection of this spring, the push rod (14) is inserted and can slide in the plug (21). For the purpose of changing the displacement of the push rod through the cam (27) and adjusting nut (32) are provided the pedal that can be tilted in any direction around the fulcrum of the cam (27) center.

The spring (10) works on the casing (1) and spring seat (7) and tries to return the push rod (14) to the zero-displacement position irrespective of the output pressure, securing its resetting to the center position.

This also has the effect of a reaction spring to give appropriate control feeling to the operator.

### 3) OPERATION

The operation of the pilot valve will be described on the basis of the hydraulic circuit diagram shown below and the attached operation explanation drawing.

The diagram shown below is the typical application example of the pilot valve.

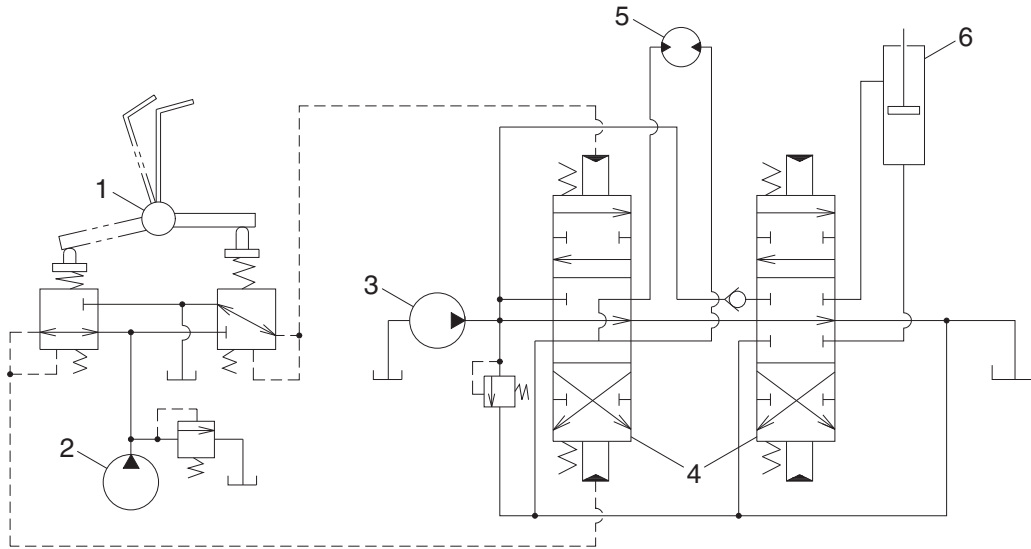

36072SF01

1 Pilot valve  
2 Pilot pump

3 Main pump  
4 Main control valve

5 Hydraulic motor  
6 Hydraulic cylinder

(1) Case where pedal is in neutral position

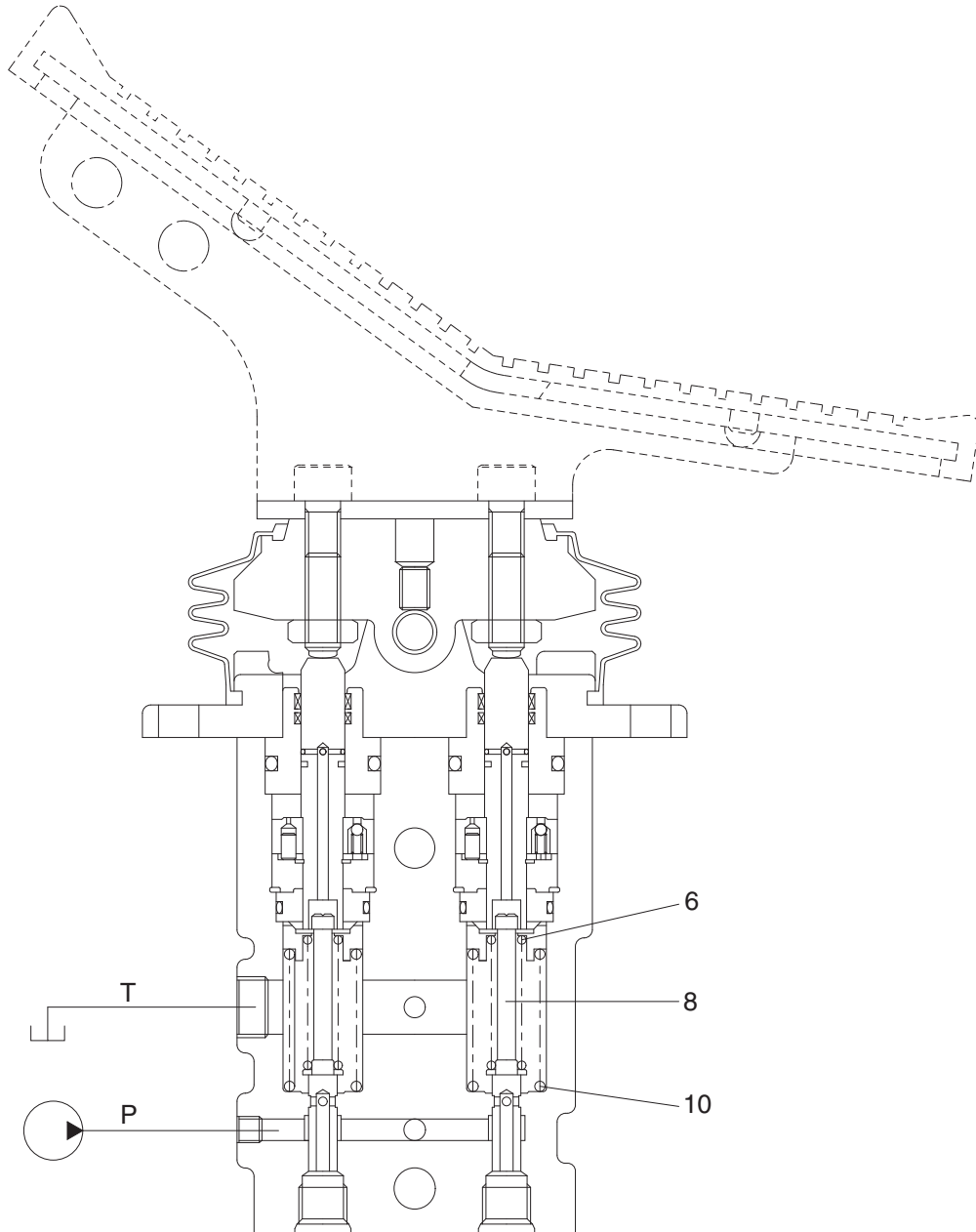

21092RP03

The force of the spring (6) that determines the output pressure of the pilot valve is not applied to the spool (8). Therefore, the spool is pushed up by the spring (10) to the position of port 2 in the operation explanation drawing. Then, since the output port is connected to tank port T only, the output port pressure becomes equal to tank pressure.

## (2) Case where pedal is tilted

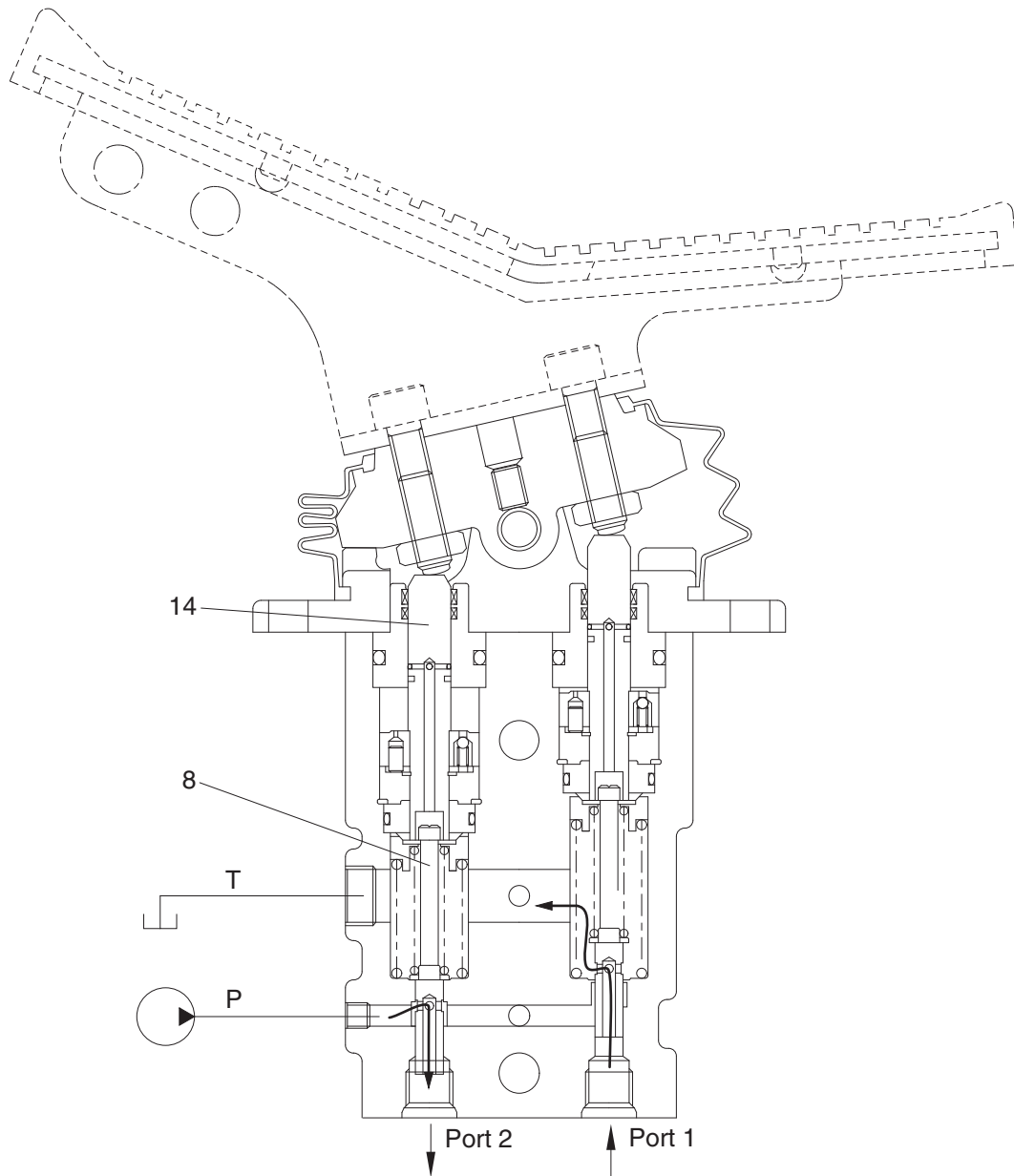

300L2RL08

When the push rod (14) is stroked, the spool (8) moves downwards.

Then port P is connected with port (2), and the oil supplied from the pilot pump flows through port 1 to generate the pressure.

When the pressure at port (2) increases to the value corresponding to the spring force set by tilting the pedal, the hydraulic pressure force balances with the spring force. If the pressure at port (1) increases higher than the set pressure, port P is disconnected from port (1) and port T is connected with port (2). If it decreases lower than the set pressure, port P is connected with port (2) and port T is disconnected from port (2).

In this manner the secondary pressure is kept at the constant value.

Besides, in some type, when the pedal is tilted more than a certain angle, the upper end of the spool contacts with inside bottom of the push rod and the output pressure is left to be connected with port P.