

# SECTION 1 GENERAL



Group 1 Safety Hints .....	1-1
Group 2 Specifications .....	1-10

# SECTION 1 GENERAL

## GROUP 1 SAFETY

### FOLLOW SAFE PROCEDURE

Unsafe work practices are dangerous. Understand service procedure before doing work; Do not attempt shortcuts.

### WEAR PROTECTIVE CLOTHING

Wear close fitting clothing and safety equipment appropriate to the job.

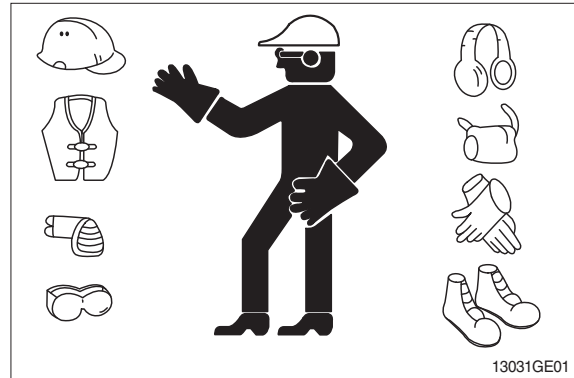

### WARN OTHERS OF SERVICE WORK

Unexpected machine movement can cause serious injury. Before performing any work on the excavator, attach a 「Do Not Operate」 tag on the right side control lever.

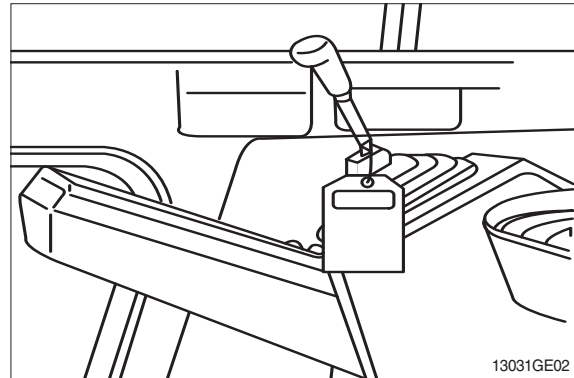

### USE HANDHOLDS AND STEPS

Falling is one of the major causes of personal injury. When you get on and off the machine, always maintain a three point contact with the steps and handrails and face the machine. Do not use any controls as handholds. Never jump on or off the machine. Never mount or dismount a moving machine. Be careful of slippery conditions on platforms, steps, and handrails when leaving the machine.

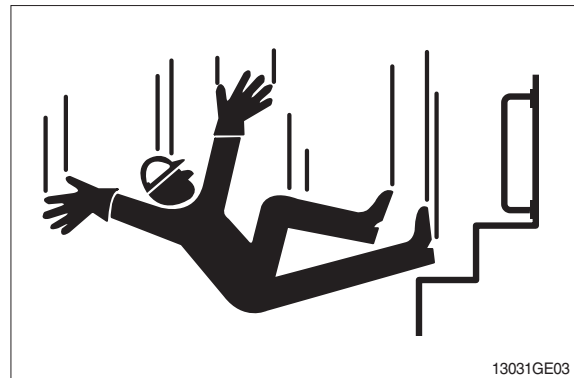

## PREPARE FOR EMERGENCIES

Be prepared if a fire starts.

Keep a first aid kit and fire extinguisher handy.

Keep emergency numbers for doctors, ambulance service, hospital, and fire department near your telephone.

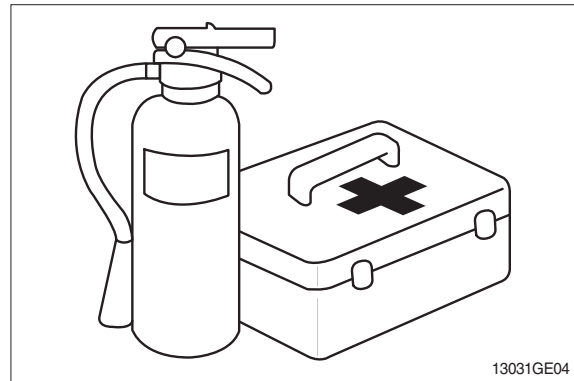

## PROTECT AGAINST FLYING DEBRIS

Guard against injury from flying pieces of metal or debris; Wear goggles or safety glasses.

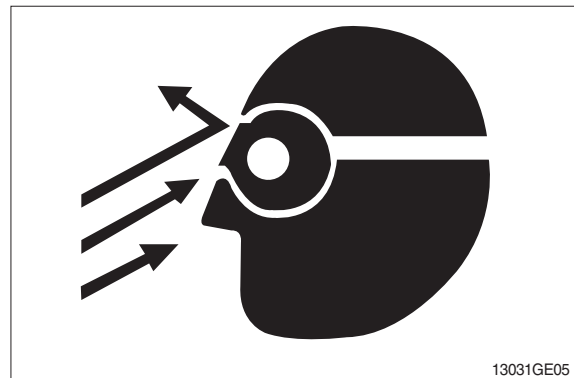

## PROTECT AGAINST NOISE

Prolonged exposure to loud noise can cause impairment or loss of hearing.

Wear a suitable hearing protective device such as earmuffs or earplugs to protect against objectionable or uncomfortable loud noises.



## AVOID POWER LINES

Serious injury or death can result from contact with electric lines.

Never move any part of the machine or load closer to electric line than 3m(10ft) plus twice the line insulator length.

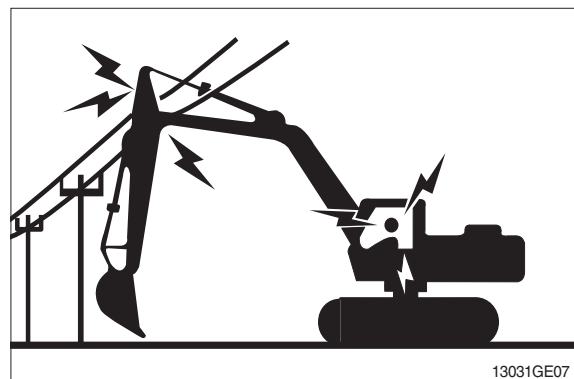

## KEEP RIDERS OFF EXCAVATOR

Only allow the operator on the excavator. Keep riders off.

Riders on excavator are subject to injury such as being struck by foreign objects and being thrown off the excavator. Riders also obstruct the operator's view resulting in the excavator being operated in an unsafe manner.

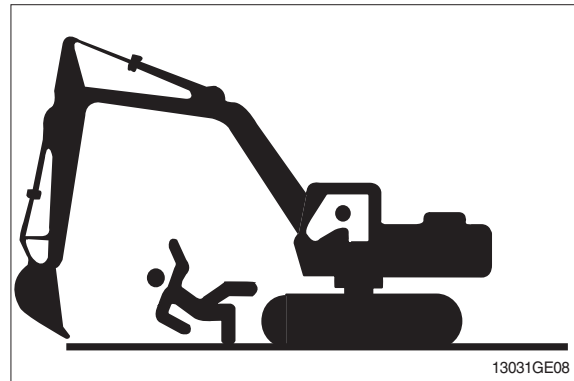

## MOVE AND OPERATE MACHINE SAFELY

Bystanders can be run over. Know the location of bystanders before moving, swinging, or operating the machine.

Always keep the travel alarm in working condition. It warns people when the excavator starts to move.

Use a signal person when moving, swinging, or operating the machine in congested areas. Coordinate hand signals before starting the excavator.

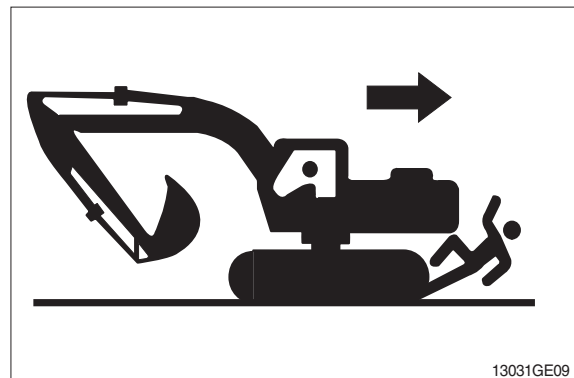

## OPERATE ONLY FROM OPERATOR'S SEAT

Avoid possible injury machine damage. Do not start engine by shorting across starter terminals.

NEVER start engine while standing on ground. Start engine only from operator's seat.



## PARK MACHINE SAFELY

Before working on the machine:

- Park machine on a level surface.
- Lower bucket to the ground.
- Turn auto idle switch off.
- Run engine at 1/2 speed without load for 2 minutes.
- Turn key switch to OFF to stop engine. Remove key from switch.
- Move pilot control shutoff lever to locked position.
- Allow engine to cool.

## SUPPORT MACHINE PROPERLY

Always lower the attachment or implement to the ground before you work on the machine. If you must work on a lifted machine or attachment, securely support the machine or attachment.

Do not support the machine on cinder blocks, hollow tiles, or props that may crumble under continuous load.

Do not work under a machine that is supported solely by a jack. Follow recommended procedures in this manual.

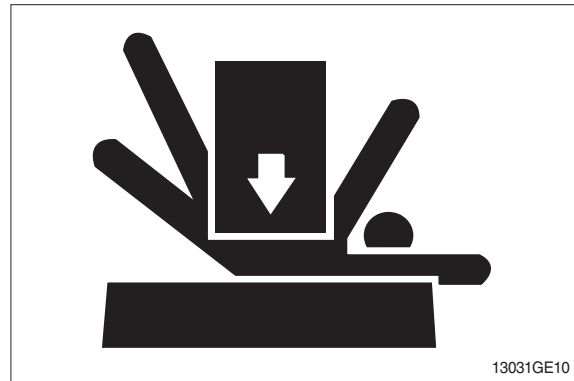

## SERVICE COOLING SYSTEM SAFELY

Explosive release of fluids from pressurized cooling system can cause serious burns.

Shut off engine. Only remove filler cap when cool enough to touch with bare hands.



## HANDLE FLUIDS SAFELY-AVOID FIRES

Handle fuel with care; It is highly flammable. Do not refuel the machine while smoking or when near open flame or sparks. Always stop engine before refueling machine. Fill fuel tank outdoors.



Store flammable fluids away from fire hazards. Do not incinerate or puncture pressurized containers.

Make sure machine is clean of trash, grease, and debris.

Do not store oily rags; They can ignite and burn spontaneously.



## BEWARE OF EXHAUST FUMES

Prevent asphyxiation. Engine exhaust fumes can cause sickness or death.

If you must operate in a building, be positive there is adequate ventilation. Either use an exhaust pipe extension to remove the exhaust fumes or open doors and windows to bring enough outside air into the area.

## REMOVE PAINT BEFORE WELDING OR HEATING

Avoid potentially toxic fumes and dust.

Hazardous fumes can be generated when paint is heated by welding, soldering, or using a torch.

Do all work outside or in a well ventilated area. Dispose of paint and solvent properly.

Remove paint before welding or heating:

- If you sand or grind paint, avoid breathing the dust.  
Wear an approved respirator.
- If you use solvent or paint stripper, remove stripper with soap and water before welding. Remove solvent or paint stripper containers and other flammable material from area. Allow fumes to disperse at least 15 minutes before welding or heating.

## ILLUMINATE WORK AREA SAFELY

Illuminate your work area adequately but safely. Use a portable safety light for working inside or under the machine. Make sure the bulb is enclosed by a wire cage. The hot filament of an accidentally broken bulb can ignite spilled fuel or oil.

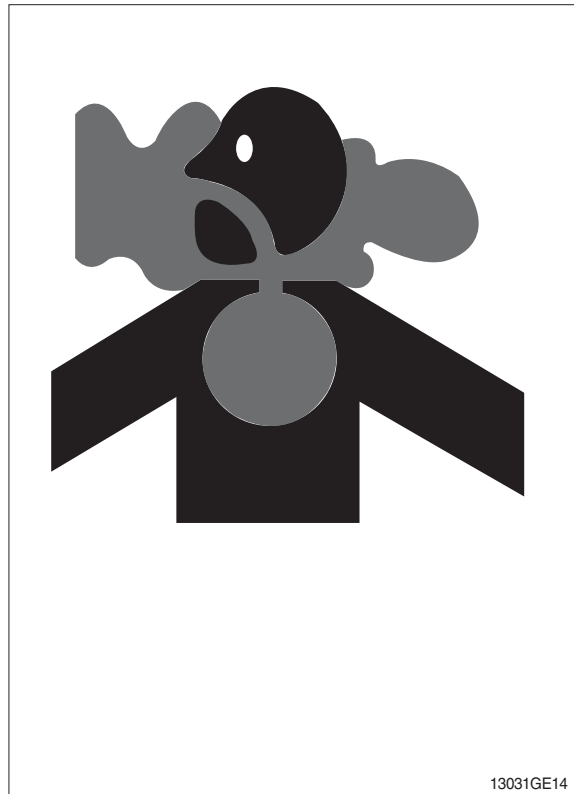

## SERVICE MACHINE SAFELY

Tie long hair behind your head. Do not wear a necktie, scarf, loose clothing or necklace when you work near machine tools or moving parts. If these items were to get caught, severe injury could result.

Remove rings and other jewelry to prevent electrical shorts and entanglement in moving parts.

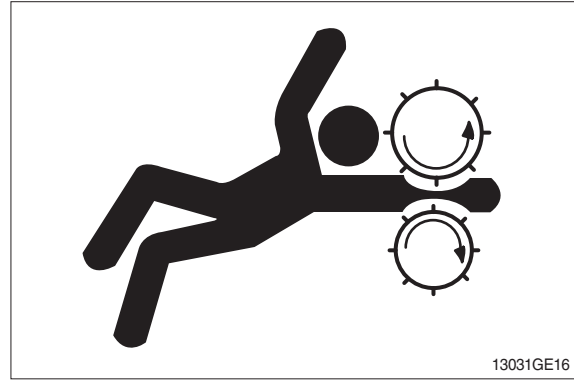

## STAY CLEAR OF MOVING PARTS

Entanglements in moving parts can cause serious injury.

To prevent accidents, use care when working around rotating parts.

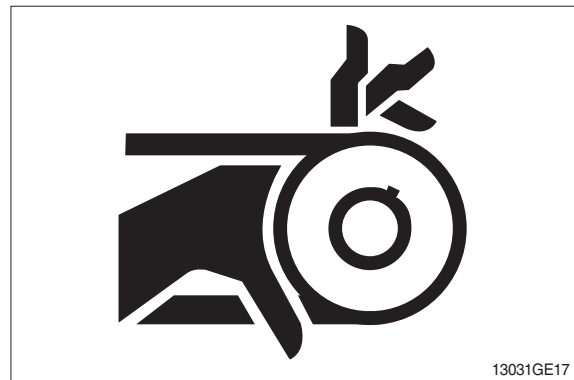

## AVOID HIGH PRESSURE FLUIDS

Escaping fluid under pressure can penetrate the skin causing serious injury.

Avoid the hazard by relieving pressure before disconnecting hydraulic or other lines. Tighten all connections before applying pressure.

Search for leaks with a piece of cardboard. Protect hands and body from high pressure fluids.

If an accident occurs, see a doctor immediately. Any fluid injected into the skin must be surgically removed within a few hours or gangrene may result.

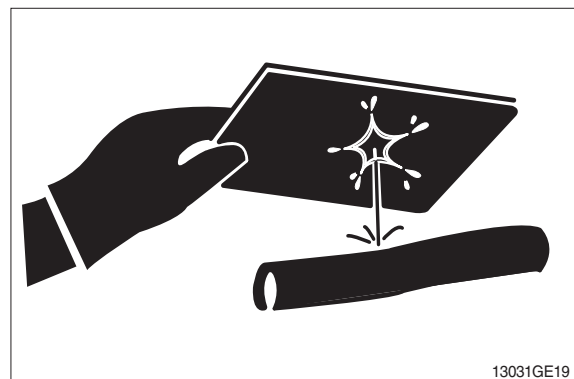

## AVOID HEATING NEAR PRESSURIZED FLUID LINES

Flammable spray can be generated by heating near pressurized fluid lines, resulting in severe burns to yourself and bystanders. Do not heat by welding, soldering, or using a torch near pressurized fluid lines or other flammable materials.

Pressurized lines can be accidentally cut when heat goes beyond the immediate flame area. Install fire resisting guards to protect hoses or other materials.



## PREVENT BATTERY EXPLOSIONS

Keep sparks, lighted matches, and flame away from the top of battery. Battery gas can explode.

Never check battery charge by placing a metal object across the posts. Use a volt-meter or hydrometer.

Do not charge a frozen battery; It may explode. Warm battery to 16°C (60°F).





## PREVENT ACID BURNS

Sulfuric acid in battery electrolyte is poisonous. It is strong enough to burn skin, eat holes in clothing, and cause blindness if splashed into eyes.

Avoid the hazard by:

1. Filling batteries in a well-ventilated area.
2. Wearing eye protection and rubber gloves.
3. Avoiding breathing fumes when electrolyte is added.
4. Avoiding spilling or dripping electrolyte.
5. Use proper jump start procedure.

If you spill acid on yourself:

1. Flush your skin with water.
2. Apply baking soda or lime to help neutralize the acid.
3. Flush your eyes with water for 10-15 minutes. Get medical attention immediately.

If acid is swallowed:

1. Drink large amounts of water or milk.
2. Then drink milk of magnesia, beaten eggs, or vegetable oil.
3. Get medical attention immediately.

## USE TOOLS PROPERLY

Use tools appropriate to the work. Makeshift tools, parts, and procedures can create safety hazards.

Use power tools only to loosen threaded tools and fasteners.

For loosening and tightening hardware, use the correct size tools. **DO NOT** use U.S. measurement tools on metric fasteners. Avoid bodily injury caused by slipping wrenches.

Use only recommended replacement parts. (See Parts catalogue.)

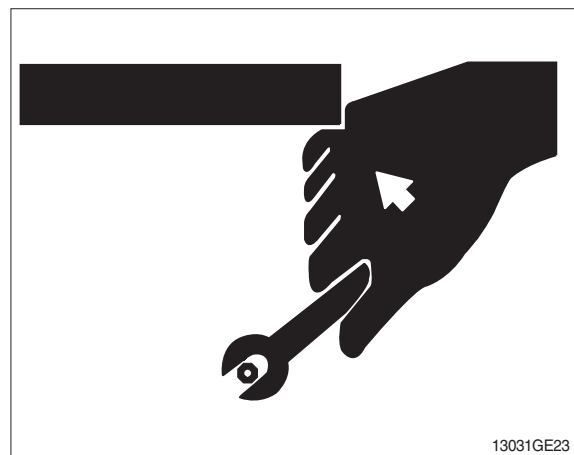
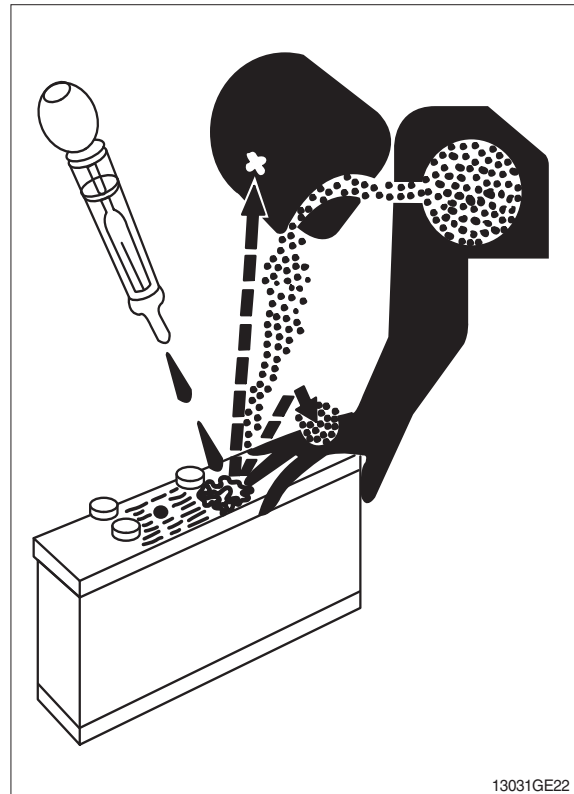

## DISPOSE OF FLUIDS PROPERLY

Improperly disposing of fluids can harm the environment and ecology. Before draining any fluids, find out the proper way to dispose of waste from your local environmental agency.

Use proper containers when draining fluids. Do not use food or beverage containers that may mislead someone into drinking from them.

DO NOT pour oil into the ground, down a drain, or into a stream, pond, or lake. Observe relevant environmental protection regulations when disposing of oil, fuel, coolant, brake fluid, filters, batteries, and other harmful waste.

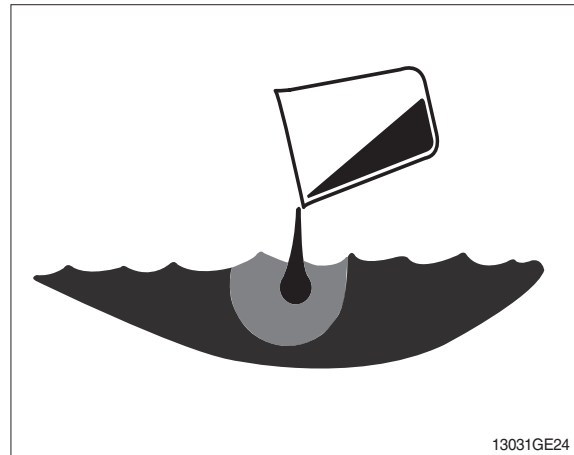

## REPLACE SAFETY SIGNS

Replace missing or damaged safety signs. See the machine operator's manual for correct safety sign placement.

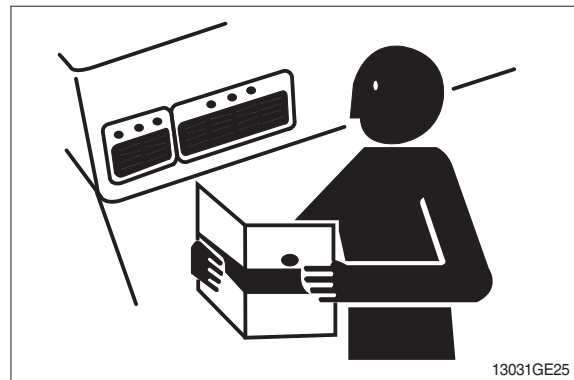

## LIVE WITH SAFETY

Before returning machine to customer, make sure machine is functioning properly, especially the safety systems. Install all guards and shields.

# GROUP 2 SPECIFICATIONS

## 1. MAJOR COMPONENT

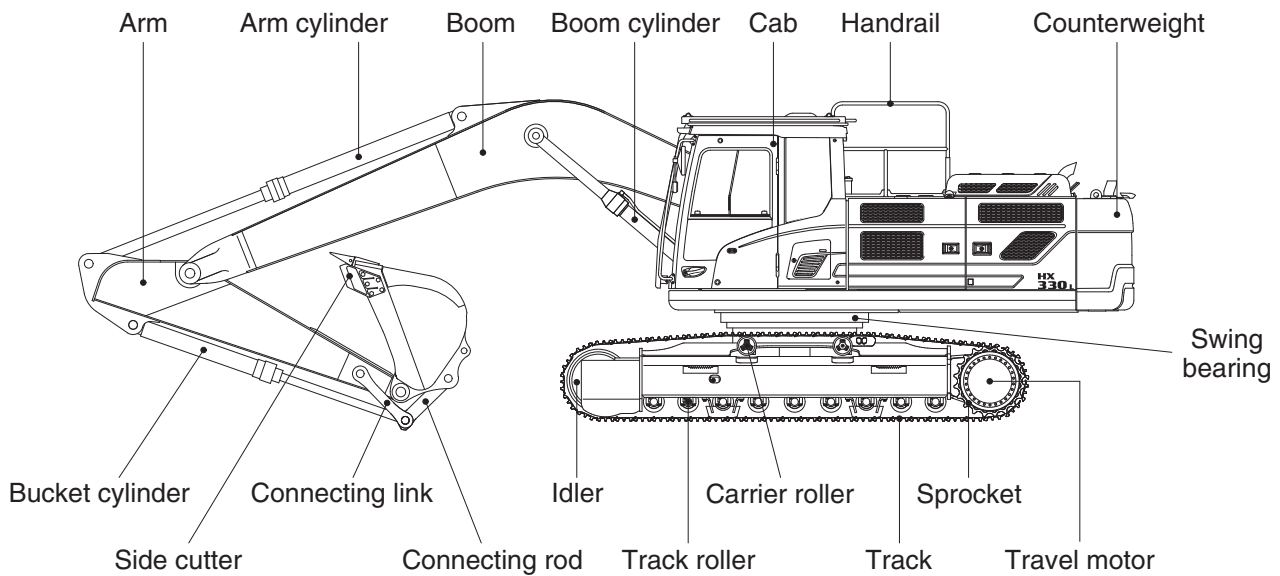
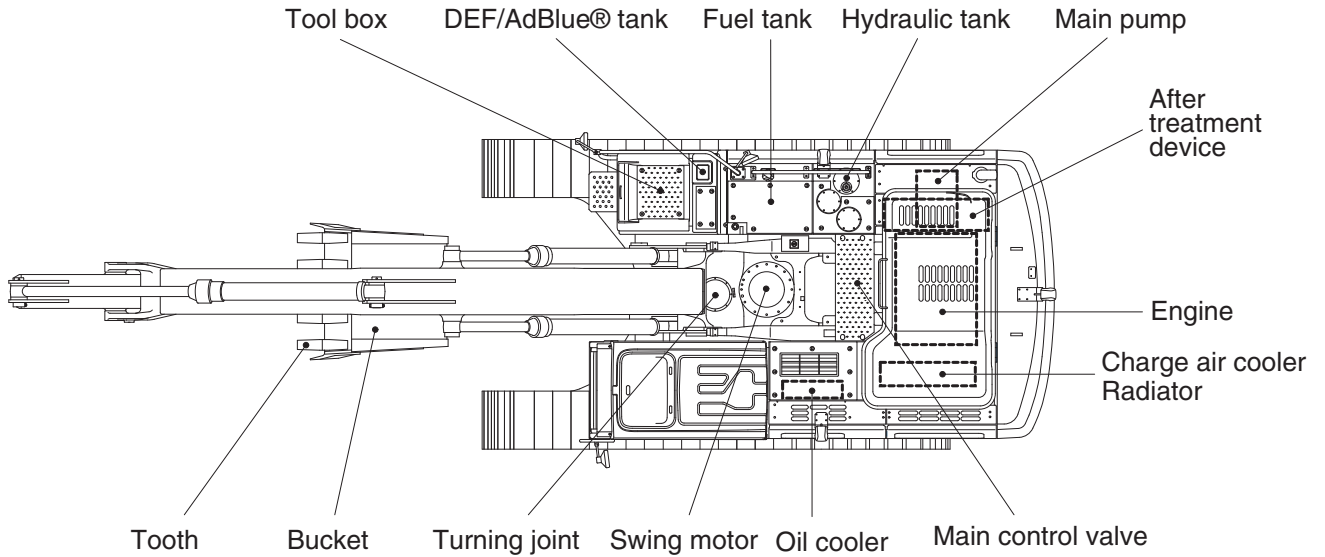

330F2SP01

## 2. SPECIFICATIONS

### 1) HX330 L

· 6.45 m (21' 2") BOOM and 3.20 m (10' 6") ARM

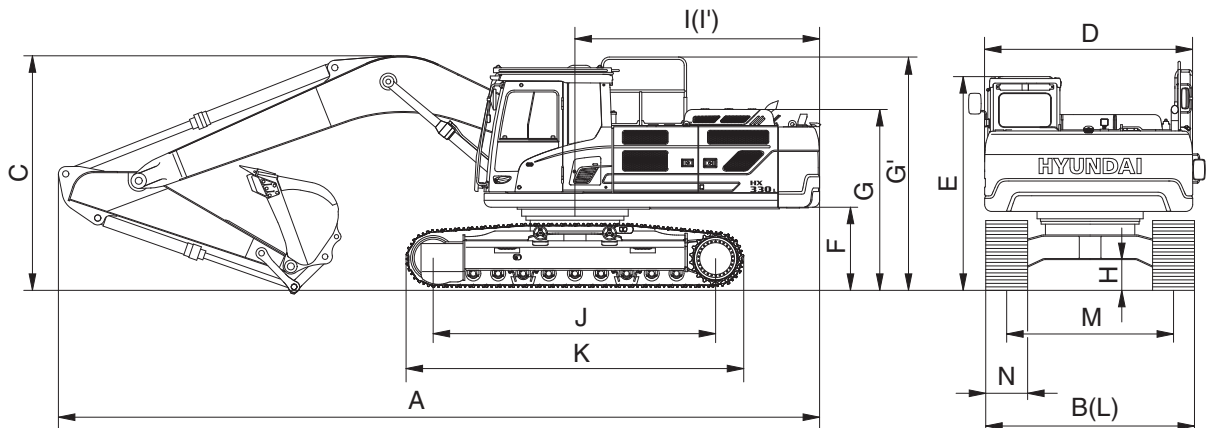

330F2SP02

Description		Unit	Specification
Operating weight		kg (lb)	33500 (73850)
Bucket capacity (SAE heaped), standard		m <sup>3</sup> (yd <sup>3</sup> )	1.44 (1.88)
Overall length	A	mm (ft-in)	11220 (36' 10")
Overall width, with 600 mm shoe	B		3280 (10' 9")
Overall height of boom	C		3380 (11' 1")
Superstructure width	D		2980 ( 9' 9")
Overall height of cab	E		3160 (10' 4")
Ground clearance of counterweight	F		1200 ( 3' 11")
Overall height of engine hood	G		2610 ( 8' 7")
Overall height of handrail	G'		3350 (11' 0")
Minimum ground clearance	H		500 ( 1' 8")
Rear-end distance	I		3505 (11' 6")
Rear-end swing radius	I'		3570 (11' 9")
Distance between tumblers	J		4030 (13' 3")
Undercarriage length	K		4940 (16' 2")
Undercarriage width	L		3280 (10' 9")
Track gauge	M		2680 ( 8' 10")
Track shoe width, standard	N		600 (24")
Travel speed (low/high)		km/hr (mph)	3.4/5.9 (2.1/3.7)
Swing speed		rpm	9.1
Gradeability		Degree (%)	35 (70)
Ground pressure (600 mm shoe)		kgf/cm <sup>2</sup> (psi)	0.65 (9.24)
Max traction force		kg (lb)	27000 (59520)

## 2) HX330 NL

· 6.45 m (21' 2") BOOM and 3.20 m (10' 6") ARM

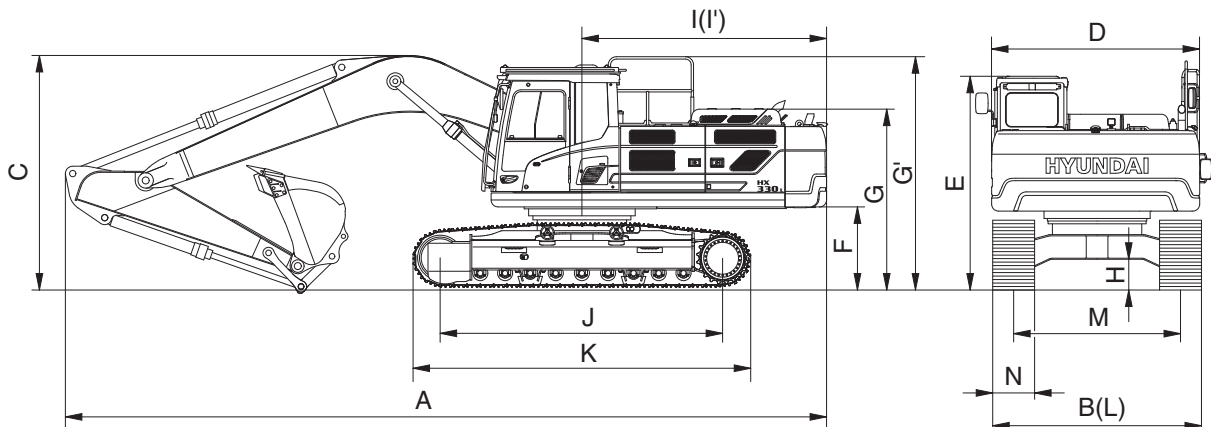

330F2SP03

Description		Unit	Specification
Operating weight		kg (lb)	33300 (73410)
Bucket capacity (SAE heaped), standard		m <sup>3</sup> (yd <sup>3</sup> )	1.44 (1.88)
Overall length	A	mm (ft-in)	11220 (36' 10")
Overall width, with 600 mm shoe	B		2990 ( 9' 10")
Overall height of boom	C		3380 (11' 1")
Superstructure width	D		2980 ( 9' 9")
Overall height of cab	E		3160 (10' 4")
Ground clearance of counterweight	F		1200 ( 3' 11")
Overall height of engine hood	G		2610 ( 8' 7")
Overall height of handrail	G'		3350 (11' 0")
Minimum ground clearance	H		500 ( 1' 8")
Rear-end distance	I		3505 (11' 6")
Rear-end swing radius	I'		3570 (11' 9")
Distance between tumblers	J		4030 (13' 3")
Undercarriage length	K		4940 (16' 2")
Undercarriage width	L		2990 ( 9' 10")
Track gauge	M		2390 ( 7' 10")
Track shoe width, standard	N		600 (24")
Travel speed (low/high)		km/hr (mph)	3.4/5.9 (2.1/3.7)
Swing speed		rpm	9.1
Gradeability		Degree (%)	35 (70)
Ground pressure (600 mm shoe)		kgf/cm <sup>2</sup> (psi)	0.64 (9.10)
Max traction force		kg (lb)	27000 (59520)

### 3) HX330 L HIGH WALKER

· 6.45 m (21' 2") BOOM and 3.20 m (10' 6") ARM

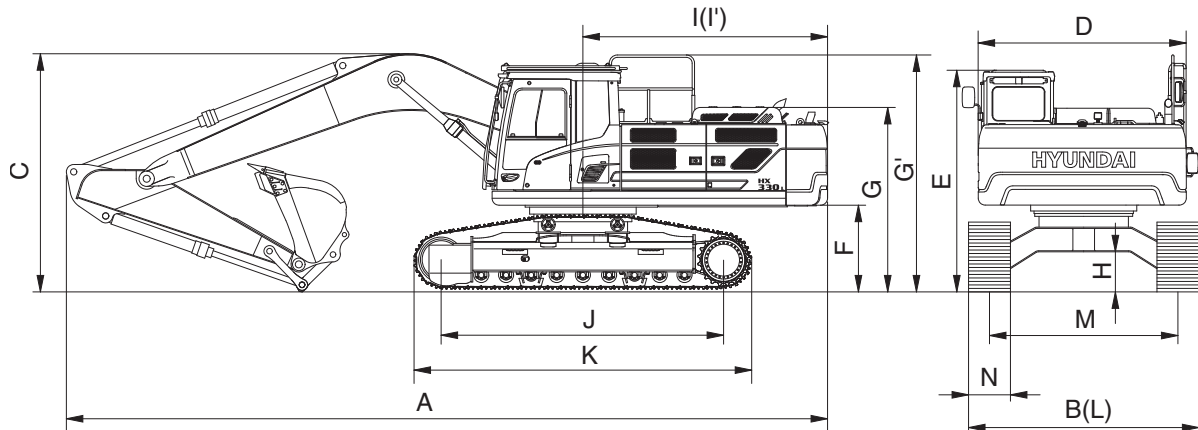

330F2SP04

Description		Unit	Specification
Operating weight		kg (lb)	36000 (79370)
Bucket capacity (SAE heaped), standard		m <sup>3</sup> (yd <sup>3</sup> )	1.44 (1.88)
Overall length	A	mm (ft-in)	11150 (36' 7")
Overall width, with 600 mm shoe	B		3470 (11' 5")
Overall height of boom	C		3360 (11' 0")
Superstructure width	D		2980 ( 9' 9")
Overall height of cab	E		3460 (11' 4")
Ground clearance of counterweight	F		1500 ( 4' 11")
Overall height of engine hood	G		2910 ( 9' 7")
Overall height of handrail	G'		3650 (12' 0")
Minimum ground clearance	H		765 ( 2' 6")
Rear-end distance	I		3505 (11' 6")
Rear-end swing radius	I'		3570 (11' 9")
Distance between tumblers	J		4030 (13' 3")
Undercarriage length	K		4940 (16' 2")
Undercarriage width	L		3470 (11' 5")
Track gauge	M		2870 ( 9' 5")
Track shoe width, standard	N		600 (24")
Travel speed (low/high)		km/hr (mph)	3.4/5.9 (2.1/3.7)
Swing speed		rpm	9.1
Gradeability		Degree (%)	35 (70)
Ground pressure (600 mm shoe)		kgf/cm <sup>2</sup> (psi)	0.69 (9.81)
Max traction force		kg (lb)	27000 (59520)

### 3. WORKING RANGE

#### 1) HX330 L/NL

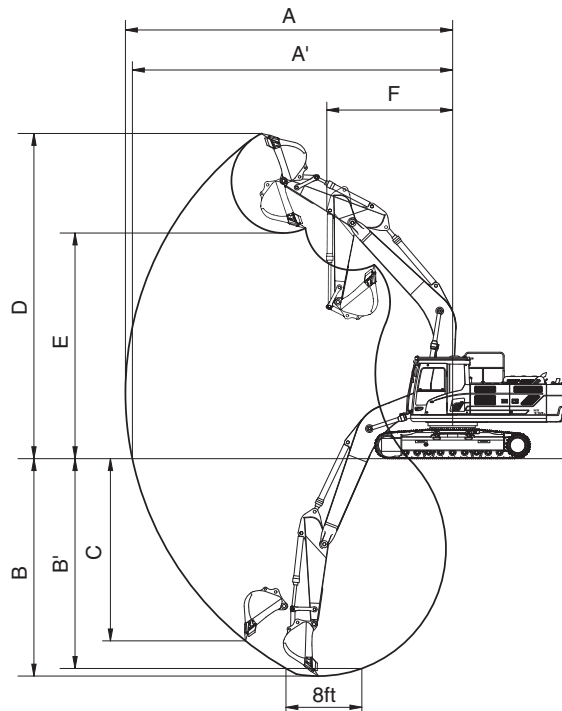

330F2SP05

Description	6.45 m (21' 2") Boom				6.15 m (20' 2") Boom	
		2.2 m (7' 3") Arm	2.5 m (8' 2") Arm	3.2 m (10' 6") Arm	4.05 m (13' 3") Arm	2.2 m (7' 3") Arm
Max digging reach	A	10330 mm (33'11")	10550 mm (34' 7")	11140 mm (36' 7")	11950 mm (39' 2")	10020 mm (32'10")
Max digging reach on ground	A'	10110 mm (33' 2")	10330 mm (33'11")	10940 mm (35'11")	11760 mm (38' 7")	9800 mm (32' 2")
Max digging depth	B	6370 mm (20'11")	6670 mm (21'11")	7370 mm (24' 2")	8220 mm (26'12")	6160 mm (20' 3")
Max digging depth (8ft level)	B'	6160 mm (20' 3")	6470 mm (21' 3")	7210 mm (23' 8")	8080 mm (26' 6")	5950 mm (19' 6")
Max vertical wall digging depth	C	5980 mm (19' 7")	5920 mm (19' 5")	6360 mm (20'10")	7260 mm (23'10")	5710 mm (18' 9")
Max digging height	D	10220 mm (33' 6")	10170 mm (33' 4")	10310 mm (33'10")	10710 mm (35' 2")	9940 mm (32' 7")
Max dumping height	E	7050 mm (23' 2")	7050 mm (23' 2")	7240 mm (23' 9")	7630 mm (25' 0")	6780 mm (22' 3")
Min swing radius	F	4700 mm (15' 5")	4550 mm (14'11")	4460 mm (14' 8")	4470 mm (14' 8")	4520 mm (14'10")
Bucket digging force	SAE	189.3 [205.5] kN	189.3 [205.5] kN	189.3 [205.5] kN	189.3 [205.5] kN	189.3 [205.5] kN
		19300 [20950] kgf	19300 [20950] kgf	19300 [20950] kgf	19300 [20950] kgf	19300 [20950] kgf
		42550 [46200] lbf	42550 [46200] lbf	42550 [46200] lbf	42550 [46200] lbf	42550 [46200] lbf
	ISO	211.8 [230.0] kN	211.8 [230.0] kN	211.8 [230.0] kN	211.8 [230.0] kN	211.8 [230.0] kN
		21600 [23450] kgf	21600 [23450] kgf	21600 [23450] kgf	21600 [23450] kgf	21600 [23450] kgf
		47620 [51700] lbf	47620 [51700] lbf	47620 [51700] lbf	47620 [51700] lbf	47620 [51700] lbf
Arm crowd force	SAE	196.6 [213.4] kN	178.9 [194.2] kN	143.2 [155.5] kN	119.6 [129.9] kN	196.6 [213.4] kN
		20000 [21760] kgf	18200 [19810] kgf	14600 [15850] kgf	12200 [13240] kgf	20000 [21760] kgf
		44190 [47980] lbf	40220 [43670] lbf	32190 [34950] lbf	26890 [29190] lbf	44190 [47980] lbf
	ISO	202.8 [220.2] kN	185.1 [201.0] kN	147.1 [159.7] kN	122.7 [133.3] kN	202.8 [220.2] kN
		20700 [22450] kgf	18900 [20500] kgf	15000 [16290] kgf	12515 [13590] kgf	20700 [22450] kgf
		45600 [49510] lbf	41620 [45190] lbf	33070 [35900] lbf	27590 [29950] lbf	45600 [49510] lbf

[ ] : Power boost

## 2) HX330 L HIGH WALKER

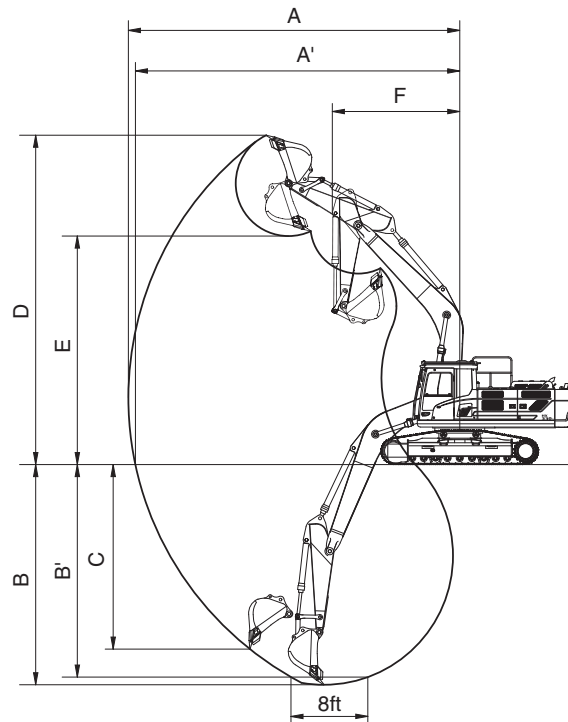

330F2SP06

Description		6.45 m (21' 2") Boom				6.15 m (20' 2") Boom
		2.2 m (7' 3") Arm	2.5 m (8' 2") Arm	3.2 m (10' 6") Arm	4.05 m (13' 3") Arm	2.2 m (7' 3") Arm
Max digging reach	A	10330 mm (33'11")	10550 mm (34' 7")	11140 mm (36' 7")	11950 mm (39' 2")	10020 mm (32'10")
Max digging reach on ground	A'	10040 mm (32'11")	10270 mm (33' 8")	10880 mm (35' 8")	11710 mm (38' 5")	9730 mm (31'11")
Max digging depth	B	6100 mm (20' 0")	6400 mm (20'12")	7100 mm (23' 4")	7950 mm (26' 1")	5880 mm (19' 3")
Max digging depth (8ft level)	B'	5890 mm (19' 4")	6200 mm (20' 4")	6940 mm (22' 9")	7800 mm (25' 7")	5680 mm (18' 8")
Max vertical wall digging depth	C	5700 mm (18' 8")	5650 mm (18' 6")	6080 mm (19'11")	6980 mm (22'11")	5440 mm (17'10")
Max digging height	D	10500 mm (34' 5")	10450 mm (34' 3")	10590 mm (34' 9")	10990 mm (36' 1")	10220 mm (33' 6")
Max dumping height	E	7330 mm (24' 1")	7330 mm (24' 1")	7520 mm (24' 8")	7910 mm (25'11")	7060 mm (23' 2")
Min swing radius	F	4700 mm (15' 5")	4550 mm (14'11")	4460 mm (14' 8")	4470 mm (14' 8")	4520 mm (14'10")
Bucket digging force	SAE	189.3 [205.5] kN	189.3 [205.5] kN	189.3 [205.5] kN	189.3 [205.5] kN	189.3 [205.5] kN
		19300 [20950] kgf	19300 [20950] kgf	19300 [20950] kgf	19300 [20950] kgf	19300 [20950] kgf
		42550 [46200] lbf	42550 [46200] lbf	42550 [46200] lbf	42550 [46200] lbf	42550 [46200] lbf
	ISO	211.8 [230.0] kN	211.8 [230.0] kN	211.8 [230.0] kN	211.8 [230.0] kN	211.8 [230.0] kN
		21600 [23450] kgf	21600 [23450] kgf	21600 [23450] kgf	21600 [23450] kgf	21600 [23450] kgf
Arm crowd force	SAE	196.6 [213.4] kN	178.9 [194.2] kN	143.2 [155.5] kN	119.6 [129.9] kN	196.6 [213.4] kN
		20000 [21760] kgf	18200 [19810] kgf	14600 [15850] kgf	12200 [13240] kgf	20000 [21760] kgf
		44190 [47980] lbf	40220 [43670] lbf	32190 [34950] lbf	26890 [29190] lbf	44190 [47980] lbf
	ISO	202.8 [220.2] kN	185.1 [201.0] kN	147.1 [159.7] kN	122.7 [133.3] kN	202.8 [220.2] kN
		20700 [22450] kgf	18900 [20500] kgf	15000 [16290] kgf	12515 [13590] kgf	20700 [22450] kgf
		45600 [49510] lbf	41620 [45190] lbf	33070 [35900] lbf	27590 [29950] lbf	45600 [49510] lbf

[ ] : Power boost



## 4. WEIGHT

### 1) HX330 L, HX330 NL

Item	HX330 L		HX330 NL	
	kg	lb	kg	lb
Upperstructure assembly				
· Main frame weld assembly	3910	8620	←	←
· Engine assembly	710	1560	←	←
· Main pump assembly	200	440	←	←
· Main control valve assembly	220	490	←	←
· Swing motor assembly	370	820	←	←
· Hydraulic oil tank assembly	250	550	←	←
· Fuel tank assembly	260	570	←	←
· Counterweight	6000	13230	←	←
· Cab assembly	500	1102	←	←
· Radiator assy	230	510	←	←
· Oil cooler assy	80	180	←	←
Lower chassis assembly				
· Track frame weld assembly	3970	8750	3835	8450
· Swing bearing	470	1040	←	←
· Travel motor assembly	440	970	←	←
· Turning joint	50	110	←	←
· Tension cylinder	225	470	←	←
· Idler	250	550	←	←
· Sprocket	80	180	←	←
· Carrier roller	40	90	←	←
· Track roller	60	130	←	←
· Track-chain assembly (600 mm standard triple grouser shoe)	1880	4145	←	←
Front attachment assembly				
· 6.45 m boom assembly	2560	5640	←	←
· 3.2 m arm assembly	1170	2580	←	←
· 1.44 m <sup>3</sup> SAE heaped bucket	1230	2710	←	←
· Boom cylinder assembly	305	670	←	←
· Arm cylinder assembly	380	840	←	←
· Bucket cylinder assembly	265	580	←	←
· Bucket control linkage assembly	370	820	←	←

※ This information is different with operating and transportation weight because it is not including harness, pipe, oil, fuel so on.

※ Refer to Transportation for actual weight information and Specifications for operating weight.

## 2) HX330 L HIGH WALKER

Item	kg	lb
Upperstructure assembly		
· Main frame weld assembly	3910	8620
· Engine assembly	710	1560
· Main pump assembly	200	440
· Main control valve assembly	220	490
· Swing motor assembly	370	820
· Hydraulic oil tank assembly	250	550
· Fuel tank assembly	260	570
· Counterweight	6000	13230
· Cab assembly	500	1100
· Radiator assy	230	510
· Oil cooler assy	80	180
Lower chassis assembly		
· Track frame weld assembly	6180	13620
· Swing bearing	470	1040
· Travel motor assembly	440	970
· Turning joint	50	110
· Tension cylinder	225	470
· Idler	250	550
· Sprocket	80	180
· Carrier roller	60	130
· Track roller	60	130
· Track-chain assembly (600 mm standard triple grouser shoe)	1880	4145
Front attachment assembly		
· 6.45 m boom assembly	2560	5640
· 3.2 m arm assembly	1170	2580
· 1.44 m <sup>3</sup> SAE heaped bucket	1230	2710
· Boom cylinder assembly	305	670
· Arm cylinder assembly	380	840
· Bucket cylinder assembly	265	580
· Bucket control linkage assembly	370	820

※ This information is different with operating and transportation weight because it is not including harness, pipe, oil, fuel so on.











※ Refer to Transportation for actual weight information and Specifications for operating weight.

## 5. LIFTING CAPACITIES

### 1) HX330 L

(1) 6.15 m (20' 2") boom, 2.2 m (7' 3") arm equipped with 1.44 m<sup>3</sup> (SAE heaped) bucket and 600 mm (24") triple grouser shoe.

-  : Rating over-front
-  : Rating over-side or 360 degree

Load point height		Load radius								At max. reach		
		3.0 m (9.8 ft)		4.5 m (14.7 ft)		6.0 m (19.6 ft)		7.5 m (24.5 ft)		Capacity		Reach
												m (ft)
7.5 m (25.0 ft)	kg lb									*7380 *16270	6080 13400	7.69 (25.2)
6.0 m (20.0 ft)	kg lb					*8280 *18250	*8280 *18250	*7970 *17570	6200 13670	*7440 *16400	4850 10690	8.61 (28.2)
4.5 m (15.0 ft)	kg lb			*11980 *26410	*11980 *26410	*9530 *21010	8850 19510	*8390 *18500	6060 13360	6600 14550	4230 9330	9.16 (30.1)
3.0 m (10.0 ft)	kg lb			*15470 *34110	13010 28680	*11120 *24520	8350 18410	9080 20020	5830 12850	6220 13710	3950 8710	9.39 (30.8)
1.5 m (5.0 ft)	kg lb			*17910 *39480	12210 26920	*12530 *27620	7920 17460	8840 19490	5600 12350	6190 13650	3910 8620	9.35 (30.7)
Ground Line	kg lb			*18640 *41090	11930 26300	12410 27360	7660 16890	8670 19110	5450 12020	6530 14400	4120 9080	9.02 (29.6)
-1.5 m (-5.0 ft)	kg lb	*16990 *37460	*16990 *37460	*18160 *40040	11930 26300	12320 27160	7580 16710	8630 19030	5420 11950	7400 16310	4690 10340	8.37 (27.5)
-3.0 m (-10.0 ft)	kg lb	*22830 *50330	*22830 *50330	*16550 *36490	12120 26720	*12300 *27120	7690 16950			*8260 *18210	5970 13160	7.29 (23.9)
-4.5 m (-15.0 ft)	kg lb	*17800 *39240	*17800 *39240	*13080 *28840	12560 27690							

- Note
1. Lifting capacity are based on SAE J1097 and ISO 10567.
  2. Lifting capacity of the ROBEX series does not exceed 75% of tipping load with the machine on firm, level ground or 87% of full hydraulic capacity.
  3. The load point is a hook located on the back of the bucket.
  4. \*indicates load limited by hydraulic capacity.

※ Lifting capacities are based upon a standard machine conditions.

Lifting capacities will vary with different work tools, ground conditions and attachments.











The difference between the weight of a work tool attachment must be subtracted.

Consult your Hyundai dealer regarding the lifting capacities for specific work tools and attachments.

▲ Failure to comply to the rated load can cause possible personal injury or property damage. Make adjustments to the rated load as necessary for non-standard configurations.













(2) 6.45 m (21' 2") boom, 2.2 m (7' 3") arm equipped with 1.44 m<sup>3</sup> (SAE heaped) bucket and 600 mm (24") triple grouser shoe.

-  : Rating over-front
-  : Rating over-side or 360 degree

Load point height		Load radius								At max. reach		
		3.0 m (9.8 ft)		4.5 m (14.7 ft)		6.0 m (19.6 ft)		7.5 m (24.5 ft)		Capacity		Reach
												m (ft)
7.5 m (25.0 ft)	kg									*7020	5490	8.07
	lb									*15480	12100	(26.5)
6.0 m (20.0 ft)	kg					*8120	*8120	*7600	6140	6900	4430	8.95
	lb					*17900	*17900	*16760	13540	15210	9770	(29.4)
4.5 m (15.0 ft)	kg			*12260	*12260	*9450	8660	*8150	5950	6140	3890	9.47
	lb			*27030	*27030	*20830	19090	*17970	13120	13540	8580	(31.1)
3.0 m (10.0 ft)	kg					*11050	8120	8930	5690	5790	3630	9.70
	lb					*24360	17900	19690	12540	12760	8000	(31.8)
1.5 m (5.0 ft)	kg					*12410	7680	8670	5450	5770	3600	9.66
	lb					*27360	16930	19110	12020	12720	7940	(31.7)
Ground Line	kg			*18350	11600	12150	7430	8500	5290	6060	3780	9.34
	lb			*40450	25570	26790	16380	18740	11660	13360	8330	(30.6)
-1.5 m (-5.0 ft)	kg	*14500	*14500	*17770	11640	12080	7370	8460	5250	6810	4280	8.72
	lb	*31970	*31970	*39180	25660	26630	16250	18650	11570	15010	9440	(28.6)
-3.0 m (-10.0 ft)	kg	*22000	*22000	*16270	11850	12210	7480			*7830	5360	7.70
	lb	*48500	*48500	*35870	26120	26920	16490			*17260	11820	(25.3)
-4.5 m (-15.0 ft)	kg	*17710	*17710	*13290	12270							
	lb	*39040	*39040	*29300	27050							















(3) 6.45 m (21' 2") boom, 2.5 m (8' 2") arm equipped with 1.44 m<sup>3</sup> (SAE heaped) bucket and 600 mm (24") triple grouser shoe.

-  : Rating over-front
-  : Rating over-side or 360 degree

Load point height		Load radius										At max. reach		
		3.0 m (9.8 ft)		4.5 m (14.7 ft)		6.0 m (19.6 ft)		7.5 m (24.5 ft)		9.0 m (29.4 ft)		Capacity		Reach
														m (ft)
7.5 m (24.5 ft)	kg											*6610	5190	8.34
	lb											*14570	11440	(27.4)
6.0 m (19.6 ft)	kg						*7220	6170				6590	4220	9.19
	lb						*15920	13600				14530	9300	(30.2)
4.5 m (14.7 ft)	kg			*11490	*11490	*9010	8710	*7820	5960			5880	3710	9.70
	lb			*25330	*25330	*19860	19200	*17240	13140			12960	8180	(31.8)
3.0 m (9.8 ft)	kg			*15000	12650	*10650	8130	*8660	5670			5560	3460	9.92
	lb			*33070	27890	*23480	17920	*19090	12500			12260	7630	(32.5)
1.5 m (4.9 ft)	kg			*17450	11780	*12090	7650	8640	5410	6410	3990	5520	3420	9.88
	lb			*38470	25970	*26650	16870	19050	11930	14130	8800	12170	7540	(32.4)
Ground Line	kg			*18220	11490	12090	7360	8440	5230			5780	3580	9.57
	lb			*40170	25330	26650	16230	18610	11530			12740	7890	(31.4)
-1.5 m (-4.9 ft)	kg	*15100	*15100	*17870	11480	11980	7270	8370	5170			6450	4020	8.97
	lb	*33290	*33290	*39400	25310	26410	16030	18450	11400			14220	8860	(29.4)
-3.0 m (-9.8 ft)	kg	*22890	*22890	*16580	11660	12070	7350					*7820	4960	7.98
	lb	*50460	*50460	*36550	25710	26610	16200					*17240	10930	(26.2)
-4.5 m (-14.7 ft)	kg	*18960	*18960	*13950	12050	*10230	7640					*7180	*7180	6.42
	lb	*41800	*41800	*30750	26570	*22550	16840					*15830	*15830	(21.1)















(4) 6.45 m (21' 2") boom, 3.2 m (10' 6") arm equipped with 1.44 m<sup>3</sup> (SAE heaped) bucket and 600 mm (24") triple grouser shoe.

·  : Rating over-front      ·  : Rating over-side or 360 degree

Load point height		Load radius												At max. reach		
		1.5 m (5.0 ft)		3.0 m (10.0 ft)		4.5 m (15.0 ft)		6.0 m (20.0 ft)		7.5 m (25.0 ft)		9.0 m (30.0 ft)		Capacity		Reach
																m (ft)
7.5 m (25.0 ft)	kg									*5160	*5160			*5870	4510	9.06
	lb									*11380	*11380			*12940	9940	(29.7)
6.0 m (20.0 ft)	kg									*6410	6300			5880	3740	9.84
	lb									*14130	13890			12960	8250	(32.3)
4.5 m (15.0 ft)	kg							*8000	*8000	*7090	6040	*5360	4290	5300	3310	10.31
	lb							*17640	*17640	*15630	13320	*11820	9460	11680	7300	(33.8)
3.0 m (10.0 ft)	kg					*13300	13080	*9720	8270	*8020	5730	6570	4140	5020	3090	10.52
	lb					*29320	28840	*21430	18230	*17680	12630	14480	9130	11070	6810	(34.5)
1.5 m (5.0 ft)	kg					*16290	11990	*11360	7720	8650	5420	6390	3970	4970	3040	10.48
	lb					*35910	26430	*25040	17020	19070	11950	14090	8750	10960	6700	(34.4)
Ground Line	kg			*10320	*10320	*17800	11460	12070	7340	8400	5190	6260	3850	5160	3150	10.19
	lb			*22750	*22750	*39240	25260	26610	16180	18520	11440	13800	8490	11380	6940	(33.4)
-1.5 m (-5.0 ft)	kg	*11460	*11460	*14560	*14560	*18040	11320	11870	7160	8260	5060			5660	3470	9.63
	lb	*25260	*25260	*32100	*32100	*39770	24960	26170	15790	18210	11160			12480	7650	(31.6)
-3.0 m (-10.0 ft)	kg	*15430	*15430	*19550	*19550	*17260	11400	11870	7160	8270	5070			6690	4160	8.74
	lb	*34020	*34020	*43100	*43100	*38050	25130	26170	15790	18230	11180			14750	9170	(28.7)
-4.5 m (-15.0 ft)	kg			*21700	*21700	*15310	11680	*11330	7350					*7380	5670	7.37
	lb			*47840	*47840	*33750	25750	*24980	16200					*16270	12500	(24.2)
-6.0 m (-20.0 ft)	kg					*11240	*11240									
	lb					*24780	*24780									

(5) 6.45 m (21' 2") boom, 4.05 m (13' 3") arm equipped with 1.44 m<sup>3</sup> (SAE heaped) bucket and 600 mm (24") triple grouser shoe.











·  : Rating over-front      ·  : Rating over-side or 360 degree

Load point height		Load radius												At max. reach		
		1.5 m (5.0 ft)		3.0 m (10.0 ft)		4.5 m (15.0 ft)		6.0 m (20.0 ft)		7.5 m (25.0 ft)		9.0 m (30.0 ft)		Capacity		Reach
																m (ft)
7.5 m (25.0 ft)	kg													*5090	3700	10.00
	lb													*11220	8160	(32.8)
6.0 m (20.0 ft)	kg											*4410	*4410	5020	3120	10.71
	lb											*9720	*9720	11070	6880	(35.1)
4.5 m (15.0 ft)	kg									*6100	*6100	*5630	4330	4570	2780	11.13
	lb									*13450	*13450	*12410	9550	10080	6130	(36.5)
3.0 m (10.0 ft)	kg			*17980	*17980	*11050	*11050	*8430	*8430	*7110	5780	*6360	4130	4340	2600	11.32
	lb			*39640	*39640	*24360	*24360	*18580	*18580	*15670	12740	*14020	9110	9570	5730	(37.1)
1.5 m (5.0 ft)	kg			*10550	*10550	*14520	12330	*10270	7820	*8170	5420	6360	3930	4290	2540	11.29
	lb			*23260	*23260	*32010	27180	*22640	17240	*18010	11950	14020	8660	9460	5600	(37.0)
Ground Line	kg			*10920	*10920	*16810	11520	*11740	7330	8350	5130	6170	3750	4420	2620	11.03
	lb			*24070	*24070	*37060	25400	*25880	16160	18410	11310	13600	8270	9740	5780	(36.2)
-1.5 m (-5.0 ft)	kg	*9970	*9970	*13500	*13500	*17770	11160	11760	7050	8140	4940	6050	3650	4780	2850	10.52
	lb	*21980	*21980	*29760	*29760	*39180	24600	25930	15540	17950	10890	13340	8050	10540	6280	(34.5)
-3.0 m (-10.0 ft)	kg	*13140	*13140	*17090	*17090	*17640	11100	11650	6950	8060	4870	6040	3640	5480	3320	9.72
	lb	*28970	*28970	*37680	*37680	*38890	24470	25680	15320	17770	10740	13320	8020	12080	7320	(31.9)
-4.5 m (-15.0 ft)	kg	*16780	*16780	*21910	*21910	*16430	11260	11730	7030	8150	4950			*6870	4260	8.53
	lb	*36990	*36990	*48300	*48300	*36220	24820	25860	15500	17970	10910			*15150	9390	(28.0)
-6.0 m (-20.0 ft)	kg			*19740	*19740	*13170	11670	*9910	7320					*6610	6600	6.71
	lb			*43520	*43520	*30230	25730	*21850	16140					*14570	14550	(22.0)

## 2) HX330 NL

(1) 6.45 m (21' 2") boom, 2.2 m (7' 3") arm equipped with 1.44 m<sup>3</sup> (SAE heaped) bucket and 600 mm (24") triple grouser shoe.

-  : Rating over-front
-  : Rating over-side or 360 degree

Load point height		Load radius								At max. reach		
		3.0 m (9.8 ft)		4.5 m (14.7 ft)		6.0 m (19.6 ft)		7.5 m (24.5 ft)		Capacity		Reach
												m (ft)
7.5 m (25.0 ft)	kg lb									*7020 *15480	4640 10230	8.07 (26.5)
6.0 m (20.0 ft)	kg lb					*8120 *17900	7760 17110	*7600 *16760	5180 11420	6850 15100	3700 8160	8.95 (29.4)
4.5 m (15.0 ft)	kg lb			*12260 *27030	11550 25460	*9450 *20830	7310 16120	*8150 *17970	5000 11020	6090 13430	3210 7080	9.47 (31.1)
3.0 m (10.0 ft)	kg lb					*11050 *24360	6790 14970	8880 19580	4750 10470	5750 12680	2980 6570	9.70 (31.8)
1.5 m (5.0 ft)	kg lb					12360 27250	6360 14020	8620 19000	4520 9960	5730 12630	2940 6480	9.66 (31.7)
Ground Line	kg lb			*18350 *40450	9450 20830	12070 26610	6130 13510	8440 18610	4370 9630	6020 13270	3100 6830	9.34 (30.6)
-1.5 m (-5.0 ft)	kg lb	*14500 *31970	*14500 *31970	*17770 *39180	9500 20940	12010 26480	6070 13380	8400 18520	4330 9550	6770 14930	3530 7780	8.72 (28.6)
-3.0 m (-10.0 ft)	kg lb	*22000 *48500	19730 43500	*16270 *35870	9690 21360	12130 26740	6170 13600			*7830 *17260	4460 9830	7.70 (25.3)
-4.5 m (-15.0 ft)	kg lb	*17710 *39040	*17710 *39040	*13290 *29300	10090 22240							

- Note
1. Lifting capacity are based on SAE J1097 and ISO 10567.
  2. Lifting capacity of the ROBEX series does not exceed 75% of tipping load with the machine on firm, level ground or 87% of full hydraulic capacity.
  3. The load point is a hook located on the back of the bucket.
  4. \*indicates load limited by hydraulic capacity.

※ Lifting capacities are based upon a standard machine conditions.

Lifting capacities will vary with different work tools, ground conditions and attachments.













The difference between the weight of a work tool attachment must be subtracted.

Consult your Hyundai dealer regarding the lifting capacities for specific work tools and attachments.

▲ Failure to comply to the rated load can cause possible personal injury or property damage. Make adjustments to the rated load as necessary for non-standard configurations.













(2) 6.45 m (21' 2") boom, 2.5 m (8' 2") arm equipped with 1.44 m<sup>3</sup> (SAE heaped) bucket and 600 mm (24") triple grouser shoe.

·  : Rating over-front      ·  : Rating over-side or 360 degree

Load point height		Load radius										At max. reach					
		3.0 m (9.8 ft)		4.5 m (14.7 ft)		6.0 m (19.6 ft)		7.5 m (24.5 ft)		9.0 m (29.4 ft)		Capacity		Reach			
														m (ft)			
7.5 m (24.5 ft)	kg																
	lb														*6610	4380	8.34
														*14570	9660	(27.4)	
6.0 m (19.6 ft)	kg							*7220	5210					6550	3510	9.19	
	lb							*15920	11490					14440	7740	(30.2)	
4.5 m (14.7 ft)	kg			*11490	*11490	*9010	7350	*7820	5010					5840	3050	9.70	
	lb			*25330	*25330	*19860	16200	*17240	11050					12870	6720	(31.8)	
3.0 m (9.8 ft)	kg			*15000	10440	*10650	6800	*8660	4730					5520	2830	9.92	
	lb			*33070	23020	*23480	14990	*19090	10430					12170	6240	(32.5)	
1.5 m (4.9 ft)	kg			*17450	9620	*12090	6340	8580	4480	6360	3270			5480	2780	9.88	
	lb			*38470	21210	*26650	13980	18920	9880	14020	7210			12080	6130	(32.4)	
Ground Line	kg			*18220	9340	12010	6060	8380	4300					5740	2920	9.57	
	lb			*40170	20590	26480	13360	18470	9480					12650	6440	(31.4)	
-1.5 m (-4.9 ft)	kg	*15100	*15100	*17870	9340	11900	5970	8310	4240					6400	3290	8.97	
	lb	*33290	*33290	*39400	20590	26230	13160	18320	9350					14110	7250	(29.4)	
-3.0 m (-9.8 ft)	kg	*22890	19360	*16580	9510	11990	6040							*7820	4110	7.98	
	lb	*50460	42680	*36550	20970	26430	13320							*17240	9060	(26.2)	
-4.5 m (-14.7 ft)	kg	*18960	*18960	*13950	9870	*10230	6330							*7180	6120	6.42	
	lb	*41800	*41800	*30750	21760	*22550	13960							*15830	13490	(21.1)	

(3) 6.45 m (21' 2") boom, 3.2 m (10' 6") arm equipped with 1.44 m<sup>3</sup> (SAE heaped) bucket and 600 mm (24") triple grouser shoe.













·  : Rating over-front      ·  : Rating over-side or 360 degree

Load point height		Load radius										At max. reach						
		1.5 m (5.0 ft)		3.0 m (10.0 ft)		4.5 m (15.0 ft)		6.0 m (20.0 ft)		7.5 m (25.0 ft)		9.0 m (30.0 ft)		Capacity		Reach		
														m (ft)				
7.5 m (25.0 ft)	kg									*5160	*5160							
	lb									*11380	*11380					*12940	8330	(29.7)
6.0 m (20.0 ft)	kg									*6410	5340					5840	3090	9.84
	lb									*14130	11770					12870	6810	(32.3)
4.5 m (15.0 ft)	kg							*8000	7520	*7090	5090	*5360	3570	5260	2700	10.31		
	lb							*17640	16580	*15630	11220	*11820	7870	11600	5950	(33.8)		
3.0 m (10.0 ft)	kg					*13300	10840	*9720	6930	*8020	4780	6530	3410	4980	2500	10.52		
	lb					*29320	23900	*21430	15280	*17680	10540	14400	7520	10980	5510	(34.5)		
1.5 m (5.0 ft)	kg					*16290	9820	*11360	6400	8600	4480	6350	3250	4930	2450	10.48		
	lb					*35910	21650	*25040	14110	18960	9880	14000	7170	10870	5400	(34.4)		
Ground Line	kg			*10320	*10320	*17800	9320	11990	6030	8340	4260	6220	3130	5120	2540	10.19		
	lb			*22750	*22750	*39240	20550	26430	13290	18390	9390	13710	6900	11290	5600	(33.4)		
-1.5 m (-5.0 ft)	kg	*11460	*11460	*14560	*14560	*18040	9180	11790	5860	8210	4140			5620	2820	9.63		
	lb	*25260	*25260	*32100	*32100	*39770	20240	25990	12920	18100	9130			12390	6220	(31.6)		
-3.0 m (-10.0 ft)	kg	*15430	*15430	*19550	18810	*17260	9260	11790	5860	8220	4150			6640	3410	8.74		
	lb	*34020	*34020	*43100	41470	*38050	20410	25990	12920	18120	9150			14640	7520	(28.7)		
-4.5 m (-15.0 ft)	kg			*21700	19340	*15310	9520	*11330	6040					*7380	4710	7.37		
	lb			*47840	42640	*33750	20990	*24980	13320					*16270	10380	(24.2)		
-6.0 m (-20.0 ft)	kg					*11240	10070											
	lb					*24780	22200											

### 3) HX330 L HIGH WALKER

(1) 6.45 m (21' 2") boom, 2.5 m (8' 2") arm equipped with 1.44 m<sup>3</sup> (SAE heaped) bucket and 600 mm (24") triple grouser shoe.

-  : Rating over-front
-  : Rating over-side or 360 degree

Load point height		Load radius										At max. reach			
		3.0 m (9.8 ft)		4.5 m (14.7 ft)		6.0 m (19.6 ft)		7.5 m (24.5 ft)		9.0 m (29.4 ft)		Capacity		Reach	
														kg	lb
7.5 m (24.5 ft)	kg												*6620	5780	8.53
	lb												*14590	12740	(28.0)
6.0 m (19.6 ft)	kg							*7300	7120				*6720	4830	9.31
	lb							*16090	15700				*14820	10650	(30.5)
4.5 m (14.7 ft)	kg			*12140	*12140	*9300	*9300	*7960	6880				6410	4330	9.76
	lb			*26760	*26760	*20500	*20500	*17550	15170				14130	9550	(32.0)
3.0 m (9.8 ft)	kg			*15590	14610	*10950	9380	*8820	6590				6130	4100	9.93
	lb			*34370	32210	*24140	20680	*19440	14530				13510	9040	(32.6)
1.5 m (4.9 ft)	kg			*17710	13840	*12300	8920	9460	6340	7200	4840		6150	4100	9.84
	lb			*39040	30510	*27120	19670	20860	13980	15870	10670		13560	9040	(32.3)
Ground Line	kg			*18220	13610	*13030	8670	9290	6180				6510	4340	9.48
	lb			*40170	30000	*28730	19110	20480	13620				14350	9570	(31.1)
-1.5 m (-4.9 ft)	kg	*16440	*16440	*17710	13640	*13030	8600	9240	6130				7340	4920	8.82
	lb	*36240	*36240	*39040	30070	*28730	18960	20370	13510				16180	10850	(28.9)
-3.0 m (-9.8 ft)	kg	*22420	*22420	*16220	13860	*12130	8720						*7780	6170	7.75
	lb	*49430	*49430	*35760	30560	*26740	19220						*17150	13600	(25.4)
-4.5 m (-14.7 ft)	kg	*17900	*17900	*13210	*13210										
	lb	*39460	*39460	*29120	*29120										

- Note
1. Lifting capacity are based on SAE J1097 and ISO 10567.
  2. Lifting capacity of the ROBEX series does not exceed 75% of tipping load with the machine on firm, level ground or 87% of full hydraulic capacity.
  3. The load point is a hook located on the back of the bucket.
  4. \*indicates load limited by hydraulic capacity.

※ **Lifting capacities are based upon a standard machine conditions.**  
**Lifting capacities will vary with different work tools, ground conditions and attachments.**  
**The difference between the weight of a work tool attachment must be subtracted.**  
**Consult your Hyundai dealer regarding the lifting capacities for specific work tools and attachments.**

▲ **Failure to comply to the rated load can cause possible personal injury or property damage.**  
**Make adjustments to the rated load as necessary for non-standard configurations.**



## 6. BUCKET SELECTION GUIDE

### 1) GENERAL BUCKET

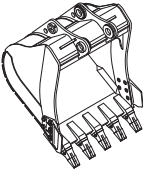
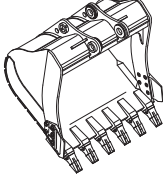
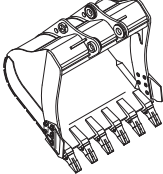
		
1.44 m <sup>3</sup> SAE heaped bucket	1.74 m <sup>3</sup> SAE heaped bucket	2.10 m <sup>3</sup> SAE heaped bucket

Capacity		Width		Weight	Recommendation				
					6.45 m (21' 2") boom				6.15 m (20' 2") boom
SAE heaped	CECE heaped	Without side cutter	With side cutter		2.2 m arm (7' 3")	2.5 m arm (8' 2")	3.2 m arm (10' 6")	4.05 m arm (13' 3")	2.2 m arm (7' 3")
1.44 m <sup>3</sup> (1.88 yd <sup>3</sup> )	1.25 m <sup>3</sup> (1.63 yd <sup>3</sup> )	1410 mm (55.5")	1505 mm (59.3")	1230 kg (2710 lb)	○	○	○	⊙	○
1.74 m <sup>3</sup> (2.28 yd <sup>3</sup> )	1.50 m <sup>3</sup> (1.96 yd <sup>3</sup> )	1640 mm (64.6")	1735 mm (68.3")	1370 kg (3020 lb)	○	○	⊙	●	○
2.10 m <sup>3</sup> (2.75 yd <sup>3</sup> )	1.83 m <sup>3</sup> (2.39 yd <sup>3</sup> )	1780 mm (70.1")	1875 mm (73.8")	1500 kg (3310 lb)	⊙	⊙	●		⊙

○ Applicable for materials with density of 2000 kgf/m<sup>3</sup> (3370 lbf/yd<sup>3</sup>) or less

⊙ Applicable for materials with density of 1600 kgf/m<sup>3</sup> (2700 lbf/yd<sup>3</sup>) or less

● Applicable for materials with density of 1100 kgf/m<sup>3</sup> (1850 lbf/yd<sup>3</sup>) or less

※ These recommendations are for general conditions and average use.

Work tools and ground conditions have effects on machine performance.

Select an optimum combination according to the working conditions and the type of work that is being done.

Consult your Hyundai dealer for information on selecting the correct boom-arm-bucket combination.

## 2) HEAVY DUTY AND ROCK-HEAVY DUTY BUCKET

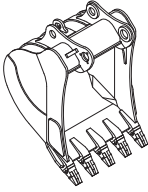
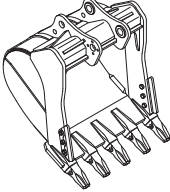
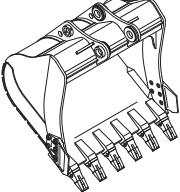
		
◆ 1.44 m <sup>3</sup> SAE heaped bucket	◆ 1.44 m <sup>3</sup> SAE ◆ 1.63 m <sup>3</sup> SAE ◆ 1.73 m <sup>3</sup> SAE heaped bucket	◆ 1.83 m <sup>3</sup> SAE heaped bucket

Capacity		Width		Weight	Recommendation				
					6.45 m (21' 2") boom				6.15 m (20' 2") boom
SAE heaped	CECE heaped	Without side cutter	With side cutter		2.2 m arm (7' 3")	2.5 m arm (8' 2")	3.2 m arm (10' 6")	4.05 m arm (13' 3")	2.2 m arm (7' 3")
◆ 1.44 m <sup>3</sup> (1.88 yd <sup>3</sup> )	1.25 m <sup>3</sup> (1.63 yd <sup>3</sup> )	1480 mm (58.3")	-	1520 kg (3350 lb)	○	○	⊙	●	○
◆ 1.44 m <sup>3</sup> (1.88 yd <sup>3</sup> )	1.25 m <sup>3</sup> (1.63 yd <sup>3</sup> )	1470 mm (57.9")	-	1610 kg (3550 lb)	○	○	⊙	●	○
◆ 1.63 m <sup>3</sup> (2.09 yd <sup>3</sup> )	1.39 m <sup>3</sup> (1.82 yd <sup>3</sup> )	1590 mm (62.6")	-	1690 kg (3730 lb)	⊙	⊙	⊙	●	○
◆ 1.73 m <sup>3</sup> (2.26 yd <sup>3</sup> )	1.5 m <sup>3</sup> (1.96 yd <sup>3</sup> )	1700 mm (66.9")	-	1760 kg (3880 lb)	⊙	⊙	●		○
◆ 1.83 m <sup>3</sup> (2.39 yd <sup>3</sup> )	1.59 m <sup>3</sup> (2.08 yd <sup>3</sup> )	1770 mm (69.7")	-	1860 kg (4100 lb)	⊙	●	●		⊙

◆ : Heavy duty bucket

◆ : Rock-Heavy duty bucket

○ Applicable for materials with density of 2000 kg/m<sup>3</sup> (3370 lb/yd<sup>3</sup>) or less

⊙ Applicable for materials with density of 1600 kg/m<sup>3</sup> (2700 lb/yd<sup>3</sup>) or less

● Applicable for materials with density of 1100 kg/m<sup>3</sup> (1850 lb/yd<sup>3</sup>) or less

## 7. UNDERCARRIAGE

### 1) TRACKS

X-leg type center frame is integrally welded with reinforced box-section track frames. The design includes dry tracks, lubricated rollers, idlers, sprockets, hydraulic track adjusters with shock absorbing springs and assembled track-type tractor shoes with triple grousers.

### 2) TYPES OF SHOES

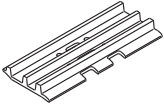
Model	Shapes		Triple grouser			
						
HX330 L	Shoe width	mm (in)	600 (24)	700 (28)	800 (32)	900 (36)
	Operating weight	kg (lb)	33500 (73850)	34070 (75110)	34450 (75950)	34830 (76790)
	Ground pressure	kgf/cm <sup>2</sup> (psi)	0.65 (9.24)	0.56 (7.96)	0.50 (7.11)	0.45 (6' 40")
	Overall width	mm (ft-in)	3280 (10' 9")	3380 (11' 1")	3480 (11' 5")	3580 (11' 9")
HX330 NL	Shoe width	mm (in)	600 (24)	-	-	-
	Operating weight	kg (lb)	33300 (73410)	-	-	-
	Ground pressure	kgf/cm <sup>2</sup> (psi)	0.64 (9.10)	-	-	-
	Overall width	mm (ft-in)	2990 (9' 10")	-	-	-
HX330 L HIGH WALKER	Shoe width	mm (in)	600 (24)	700 (28)	800 (32)	Double Grouser 710 (28)
	Operating weight	kg (lb)	36000 (79370)	36570 (80620)	36950 (81460)	37480 (82630)
	Ground pressure	kgf/cm <sup>2</sup> (psi)	0.69 (9.81)	0.60 (8.53)	0.53 (7.54)	0.61 (8.67)
	Overall width	mm (ft-in)	3470 (11' 5")	3570 (11' 9")	3670 (12' 0")	3580 (11' 9")

### 3) NUMBER OF ROLLERS AND SHOES ON EACH SIDE

Item	Quantity
Carrier rollers	2EA
Track rollers	9EA
Track shoes	48EA

#### 4) SELECTION OF TRACK SHOE

Suitable track shoes should be selected according to operating conditions.

##### Method of selecting shoes

Confirm the category from the list of applications in **table 2**, then use **table 1** to select the shoe. Wide shoes (categories B and C) have limitations on applications. Before using wide shoes, check the precautions, then investigate and study the operating conditions to confirm if these shoes are suitable.

Select the narrowest shoe possible to meet the required flotation and ground pressure. Application of wider shoes than recommendations will cause unexpected problem such as bending of shoes, crack of link, breakage of pin, loosening of shoe bolts and the other various problems.

※ **Table 1**

Track shoe	Specification	Category
600 mm triple grouser	Standard	A
700 mm triple grouser	Option	B
710 mm double grouser	Option	B
800 mm triple grouser	Option	C
900 mm triple grouser	Option	C

※ **Table 2**

Category	Applications	Applications
A	Rocky ground, river beds, normal soil	<ul style="list-style-type: none"> <li>Travel at low speed on rough ground with large obstacles such as boulders or fallen trees</li> </ul>
B	Normal soil, soft ground	<ul style="list-style-type: none"> <li>These shoes cannot be used on rough ground with large obstacles such as boulders or fallen trees</li> <li>Travel at high speed only on flat ground</li> <li>Travel slowly at low speed if it is impossible to avoid going over obstacles</li> </ul>
C	Extremely soft ground (swampy ground)	<ul style="list-style-type: none"> <li>Use the shoes only in the conditions that the machine sinks and it is impossible to use the shoes of category A or B</li> <li>These shoes cannot be used on rough ground with large obstacles such as boulders or fallen trees</li> <li>Travel at high speed only on flat ground</li> <li>Travel slowly at low speed if it is impossible to avoid going over obstacles</li> </ul>

## 8. SPECIFICATIONS FOR MAJOR COMPONENTS

### 1) ENGINE

Item	Specification
Model	Cummins QSL9
Type	4-cycle turbocharged charger air cooled diesel engine
Cooling method	Water cooling
Number of cylinders and arrangement	6 cylinders, in-line
Firing order	1-5-3-6-2-4
Combustion chamber type	Direct injection type
Cylinder bore × stroke	114 × 145 mm (4.49" × 5.69")
Piston displacement	8900 cc (543 cu in)
Compression ratio	17.8 : 1
Rated net horse power (SAE J1349)	270 Hp at 1800 rpm (202 kW at 1800 rpm)
Rated gross horse power (SAE J1995)	284 Hp at 1800 rpm (212 kW at 1800 rpm)
Maximum torque	123.7 kgf · m (895 lbf · ft) at 1500 rpm
Engine oil quantity	30 ℓ (7.9 U.S. gal)
Wet weight	708 kg (1560 lb)
High idling speed	1800+ 50 rpm
Low idling speed	800 ± 50 rpm
Rated fuel consumption	164.8 g/Hp · hr at 1800 rpm
Starting motor	Denso 24V-7.8 kW
Alternator	Denso 24V-95A
Battery	2 × 12V × 160Ah

### 2) MAIN PUMP

Item	Specification
Type	Variable displacement tandem axis piston pumps
Capacity	2 × 154 cc/rev
Rated oil flow	2 × 277 ℓ/min (73.2 U.S. gpm / 61.0 U.K. gpm)
Rated speed	1800 rpm

### 3) GEAR PUMP

Item	Specification
Type	Fixed displacement gear pump single stage
Capacity	15cc/rev
Maximum pressure	40 kgf/cm <sup>2</sup> (570 psi)
Rated oil flow	26.3 l /min (6.9 U.S. gpm/5.8 U.K. gpm)

### 4) MAIN CONTROL VALVE

Item	Specification
Type	9 spools
Operating method	Hydraulic pilot system
Main relief valve pressure	350 kgf/cm <sup>2</sup> (4980 psi) [380 kgf/cm <sup>2</sup> (5400 psi)]
Overload relief valve pressure	400 kgf/cm <sup>2</sup> (5690 psi)

[ ]: Power boost

### 5) SWING MOTOR

Item	Specification
Type	Axial piston motor
Capacity	156.9 cc/rev
Relief pressure	300 kgf/cm <sup>2</sup> (4270 psi)
Braking system	Automatic, spring applied hydraulic released
Braking torque	84.4 kgf · m (610 lbf · ft)
Brake release pressure	36.5 kgf/cm <sup>2</sup> (519 psi)
Reduction gear type	2 - stage planetary

### 6) TRAVEL MOTOR

Item	Specification
Type	Variable displacement axial piston motor
Relief pressure	350 kgf/cm <sup>2</sup> (4980 psi)
Capacity (max / min)	282.6/156.9 cc/rev
Reduction gear type	2-stage planetary
Braking system	Automatic, spring applied hydraulic released
Brake release pressure	17 kgf/cm <sup>2</sup> (242 psi)
Braking torque	134 kgf · m (969 lbf · ft)

## 7) REMOTE CONTROL VALVE

Item		Specification
Type		Pressure reducing type
Operating pressure	Minimum	6.5 kg/cm <sup>2</sup> (92 psi)
	Maximum	26 kg/cm <sup>2</sup> (370 psi)
Single operation stroke	Lever	61 mm (2.4 in)
	Pedal	123 mm (4.84 in)

## 8) CYLINDER

Item		Specification
Boom cylinder	Bore dia × Rod dia × Stroke	∅ 150 × ∅ 105 × 1480 mm
	Cushion	Extend only
Arm cylinder	Bore dia × Rod dia × Stroke	∅ 160 × ∅ 110 × 1685 mm
	Cushion	Extend and retract
Bucket cylinder	Bore dia × Rod dia × Stroke	∅ 140 × ∅ 100 × 1285 mm
	Cushion	Extend only

※ Discoloration of cylinder rod can occur when the friction reduction additive of lubrication oil spreads on the rod surface.

※ Discoloration does not cause any harmful effect on the cylinder performance.

## 9) SHOE

Item		Width	Ground pressure	Link quantity	Overall width
HX330 L	Standard	☆600 mm (24")	0.65 kgf/cm <sup>2</sup> (9.24 psi)	48	3280 mm (10' 9")
	Option	☆700 mm (28")	0.56 kgf/cm <sup>2</sup> (7.96 psi)	48	3380 mm (11' 1")
		☆800 mm (32")	0.50 kgf/cm <sup>2</sup> (7.11 psi)	48	3480 mm (11' 5")
		☆900 mm (36")	0.45 kgf/cm <sup>2</sup> (6.40 psi)	48	3580 mm (11' 9")
HX330 NL	Standard	☆600 mm (24")	0.64 kgf/cm <sup>2</sup> (9.10 psi)	48	2990 mm ( 9' 10")
HX330 L H/WALKER	Standard	☆600 mm (24")	0.69 kgf/cm <sup>2</sup> (9.81 psi)	48	3470 mm (11' 5")
	Option	☆700 mm (28")	0.60 kgf/cm <sup>2</sup> (8.53 psi)	48	3570 mm (11' 9")
		☆800 mm (32")	0.53 kgf/cm <sup>2</sup> (7.54 psi)	48	3670 mm (12' 0")
		★710 mm (28")	0.61 kgf/cm <sup>2</sup> (8.67 psi)	48	3580 mm (11' 9")

☆ : Triple grouser

★ : Double grouser

## 10) BUCKET

Item	Capacity		Tooth quantity	Width	
	SAE heaped	CECE heaped		Without side cutter	With side cutter
HX330 L HX330 NL H/WALKER	1.44 m <sup>3</sup> (1.88 yd <sup>3</sup> )	1.25 m <sup>3</sup> (1.63 yd <sup>3</sup> )	5	1410 mm (55.5")	1505 mm (59.3")
	1.74 m <sup>3</sup> (2.28 yd <sup>3</sup> )	1.50 m <sup>3</sup> (1.96 yd <sup>3</sup> )	6	1640 mm (64.5")	1735 mm (68.3")
	2.10 m <sup>3</sup> (2.75 yd <sup>3</sup> )	1.82 m <sup>3</sup> (2.39 yd <sup>3</sup> )	6	1780 mm (70.1")	1875 mm (73.8")
	◆ 1.44 m <sup>3</sup> (1.88 yd <sup>3</sup> )	1.25 m <sup>3</sup> (1.63 yd <sup>3</sup> )	5	1480 mm (58.3")	-
	◆ 1.44 m <sup>3</sup> (1.88 yd <sup>3</sup> )	1.25 m <sup>3</sup> (1.63 yd <sup>3</sup> )	5	1470 mm (57.9")	-
	◆ 1.63 m <sup>3</sup> (2.09 yd <sup>3</sup> )	1.39 m <sup>3</sup> (1.82 yd <sup>3</sup> )	5	1590 mm (62.6")	-
	◆ 1.73 m <sup>3</sup> (2.26 yd <sup>3</sup> )	1.50 m <sup>3</sup> (1.96 yd <sup>3</sup> )	5	1700 mm (66.9")	-
	◆ 1.83 m <sup>3</sup> (2.39 yd <sup>3</sup> )	1.59 m <sup>3</sup> (2.08 yd <sup>3</sup> )	6	1770 mm (69.7")	-

◆ : Heavy duty bucket

◆ : Rock-Heavy duty bucket



## 9. RECOMMENDED OILS

HYUNDAI genuine lubricating oils have been developed to offer the best performance and service life for your equipment. These oils have been tested according to the specifications of HYUNDAI and, therefore, will meet the highest safety and quality requirements.

We recommend that you use only HYUNDAI genuine lubricating oils and grease officially approved by HYUNDAI.

Service point	Kind of fluid	Capacity ℓ (U.S. gal)	Ambient temperature °C ( °F)						
			-50 (-58)	-30 (-22)	-20 (-4)	-10 (14)	0 (32)	10 (50)	20 (68)
Engine oil pan	Engine oil	30 (7.9)	★SAE 5W-40						
			SAE 30						
			SAE 10W						
			SAE 10W-30						
			SAE 15W-40						
DEF/ AdBlue® tank	Mixture of urea and deionized water	42.5 (11.2)	ISO 22241, High-purity urea + deionized water (32.5:67.5)						
Swing drive	Gear oil	11 (2.91)	★SAE 75W-90						
Final drive		7.8×2 (2.1×2)	SAE 80W-90						
Hydraulic tank	Hydraulic oil	Tank : 210 (55.5)  System : 414 (106.7)	★ISO VG 15						
			ISO VG 32						
			ISO VG 46, HBHO VG 46★ <sup>3</sup>						
			ISO VG 68						
Fuel tank	Diesel fuel★ <sup>1</sup>	600 (159)	★ASTM D975 NO.1						
			ASTM D975 NO.2						
Fitting (grease nipple)	Grease	As required	★NLGI NO.1						
			NLGI NO.2						
Radiator (reservoir tank)	Mixture of antifreeze and soft water★ <sup>2</sup>	55 (14.5)	Ethylene glycol base permanent type (50 : 50)						
			★Ethylene glycol base permanent type (60 : 40)						

**SAE** : Society of Automotive Engineers

**API** : American Petroleum Institute

**ISO** : International Organization for Standardization

**NLGI** : National Lubricating Grease Institute

**ASTM** : American Society of Testing and Material

**UTTO** : Universal Tractor Transmission Oil

**DEF** : Diesel Exhaust Fluid, DEF compatible with AdBlue®

★ : Cold region

Russia, CIS, Mongolia

★<sup>1</sup> : Ultra low sulfur diesel  
- sulfur content ≤ 15 ppm

★<sup>2</sup> : Soft water  
City water or distilled water

★<sup>3</sup> : Hyundai Bio Hydraulic Oil

- For more information, contact HYUNDAI dealers.

※ Using any lubricating oils other than HYUNDAI genuine products may lead to a deterioration of performance and cause damage to major components.

※ Do not mix HYUNDAI genuine oil with any other lubricating oil as it may result in damage to the systems of major components.

※ Do not use any engine oil other than that specified above, as it may clog the diesel particulate filter(DPF).

※ For HYUNDAI genuine lubricating oils and grease for use in regions with extremely low temperatures, please contact HYUNDAI dealers.