

SECTION 9 COMPONENT MOUNTING TORQUE

Group 1	Introduction guide	9-1
Group 2	Engine system	9-2
Group 3	Electric system	9-4
Group 4	Hydraulic system	9-6
Group 5	Undercarriage	9-9
Group 6	Structure	9-11
Group 7	Work equipment	9-15

SECTION 9 COMPONENT MOUNTING TORQUE

GROUP 1 INTRODUCTION GUIDE

1. This section shows bolt specifications and standard torque values needed when mounting components to the machine.
 2. Use genuine Hyundai spare parts.
We expressly point out that Hyundai will not accept any responsibility for defects resulted from non-genuine parts.
In such cases Hyundai cannot assume liability for any damage.
- ※ Only metric fasteners can be used and incorrect fasteners may result in machine damage or malfunction.
 - ※ Before installation, clean all the components with a non-corrosive cleaner. Bolts and threads must not be worn or damaged.

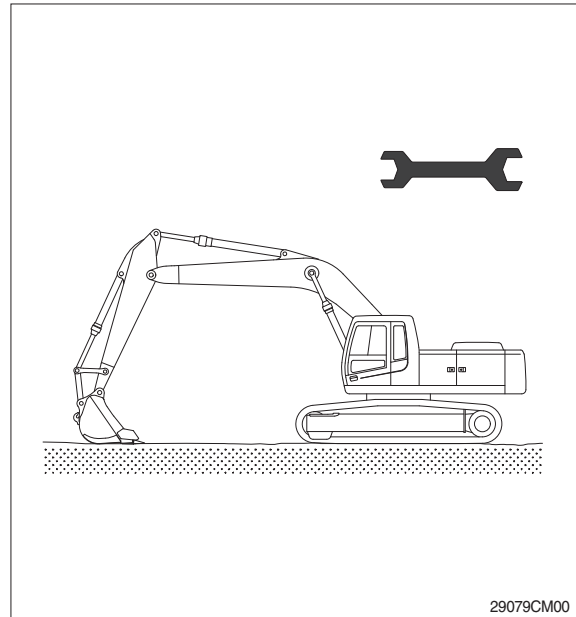

GROUP 2 ENGINE SYSTEM

ENGINE AND ACCESSORIES MOUNTING

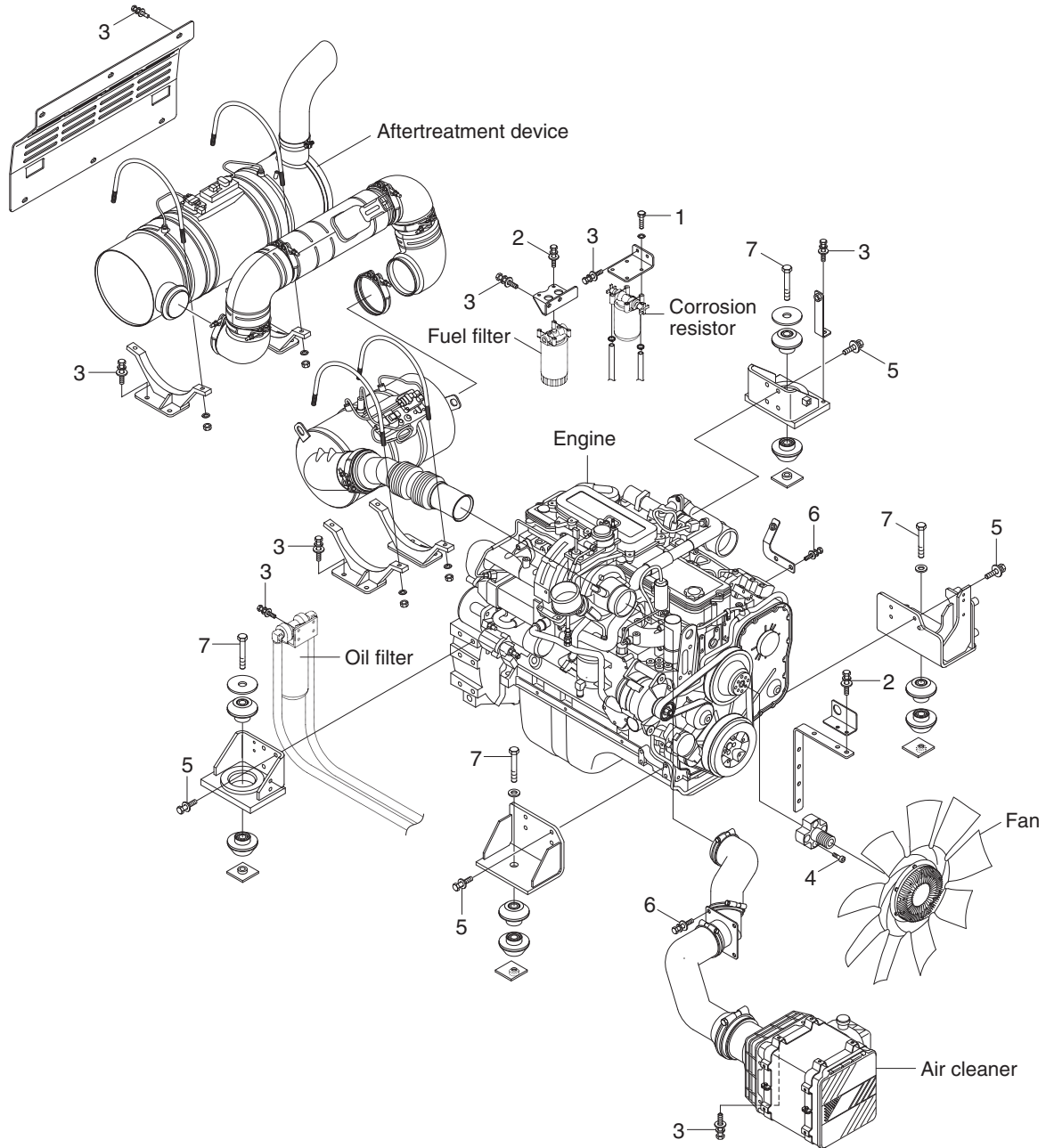

330L9CM01

· Tightening torque

Item	Size	kgf · m	lbf · ft
1	M6×1.0	1.44±0.3	10.4±2.2
2	M8×1.25	2.5±0.5	18.1±3.6
3	M10×1.5	6.9±1.4	49.9±10.1
4	M10×1.5	8.27±1.7	59.8±12.3

Item	Size	kgf · m	lbf · ft
5	M12×1.75	10±1.0	72.3±7.2
6	M12×1.75	12.8±3.0	92.6±21.7
7	M24×3.0	90±9.0	651±65
-	-	-	-

COOLING SYSTEM AND FUEL TANK MOUNTING

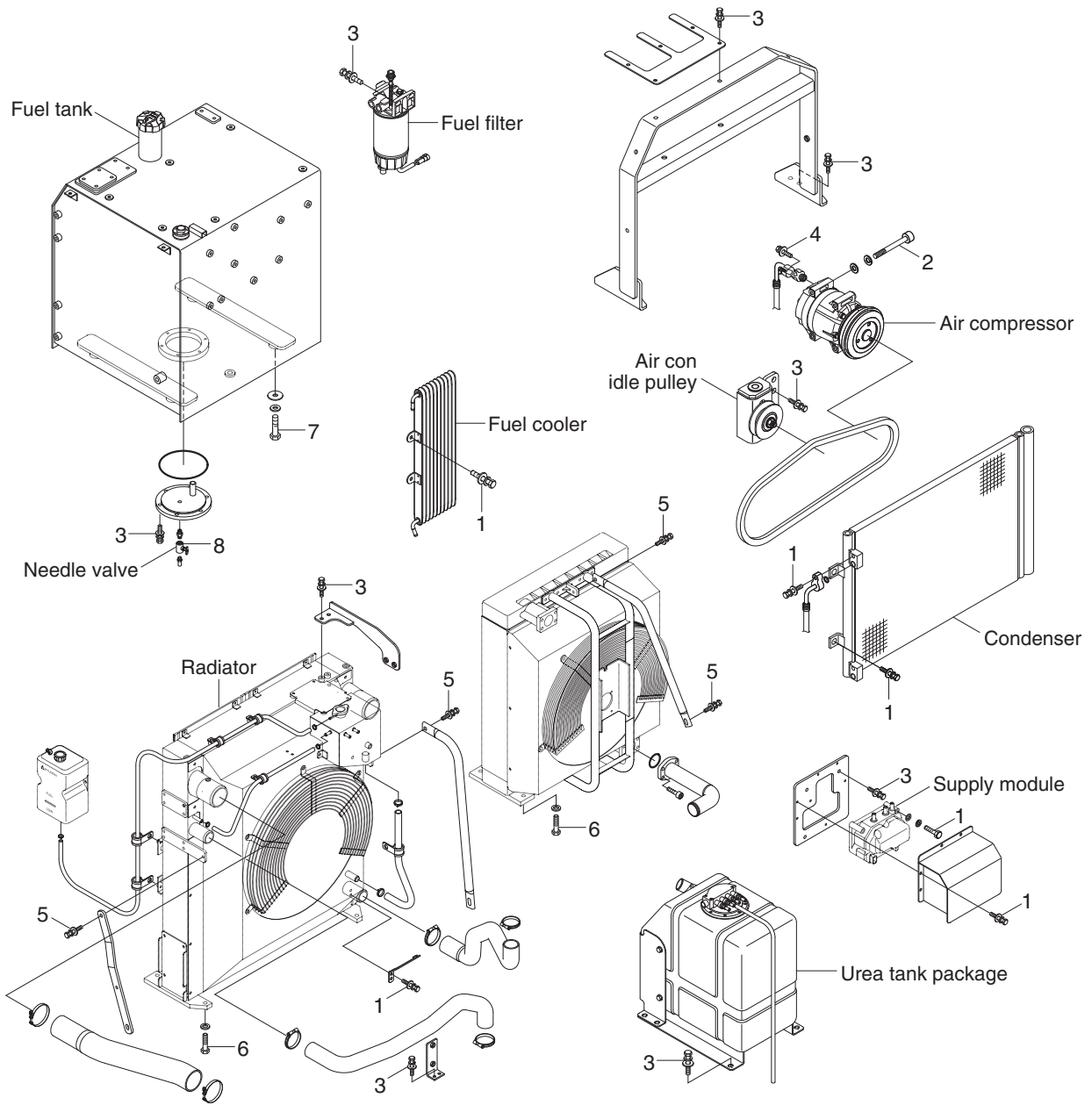

330L9CM02

· Tightening torque

Item	Size	kgf · m	lbf · ft
1	M 8×1.25	2.5±0.5	18.1±3.6
2	M 8×1.25	4.05±0.8	29.3±5.8
3	M10×1.5	6.9±1.4	49.9±10.1
4	M10×1.5	7.4±1.5	53.5±10.8

Item	Size	kgf · m	lbf · ft
5	M12×1.75	12.8±3.0	92.6±21.7
6	M16×2.0	29.7±4.5	215±32.5
7	M20×2.5	46±5.1	333±36.9
8	-	2.3±0.6	16.6±4.3

GROUP 3 ELECTRIC SYSTEM

ELECTRIC COMPONENTS MOUNTING 1

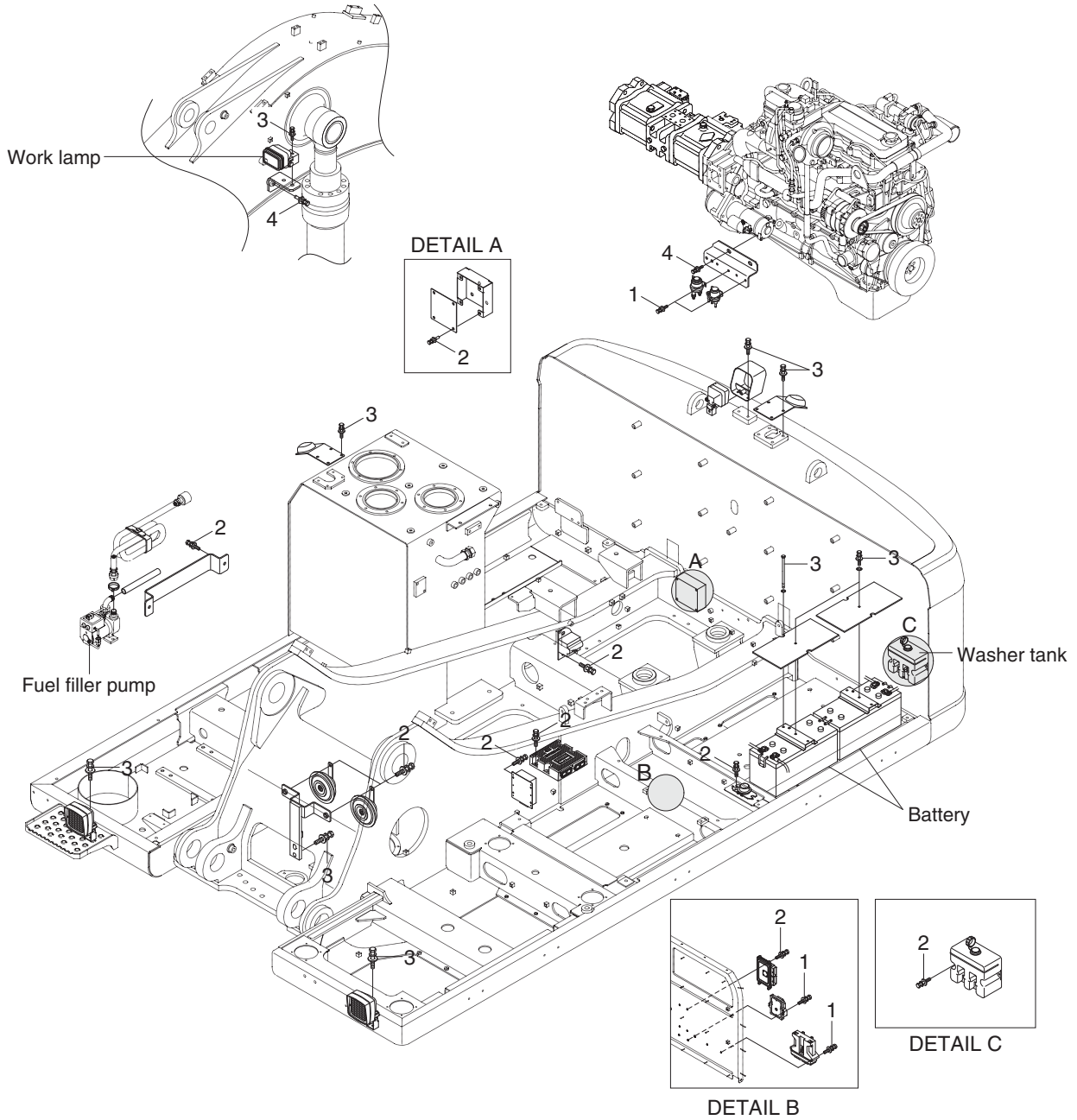

330L9CM03

· Tightening torque

Item	Size	kgf · m	lbf · ft
1	M 6×1.0	1.05±0.2	7.6±1.45
2	M 8×1.25	2.5±0.5	18.1±3.6

Item	Size	kgf · m	lbf · ft
3	M10×1.5	6.9±1.4	49.9±10.1
4	M12×1.75	12.8±3.0	92.6±21.7

ELECTRIC COMPONENTS MOUNTING 2

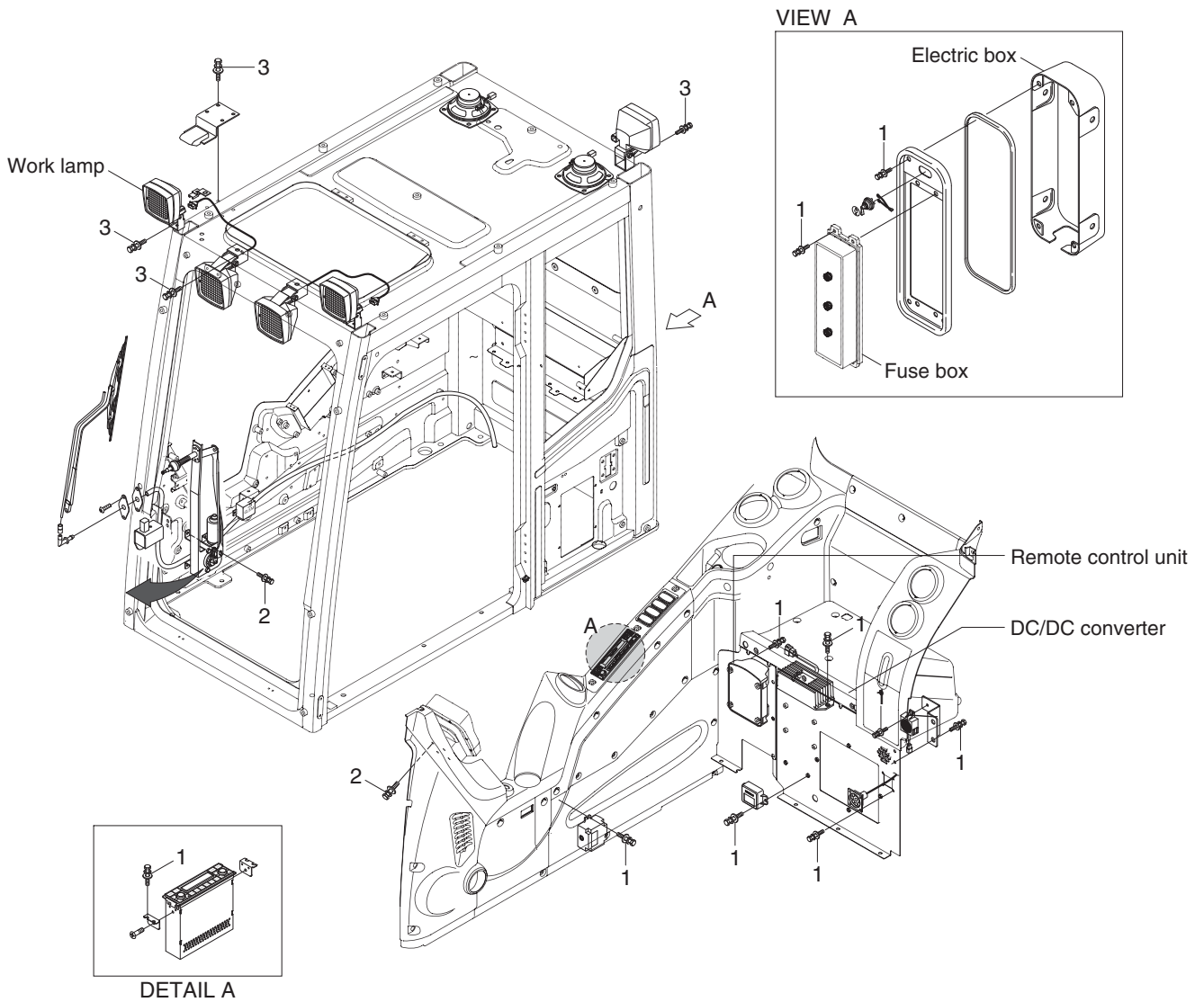

330L9CM04

· Tightening torque

Item	Size	kgf · m	lbf · ft
1	M 6×1.0	1.05±0.2	7.6±1.45
2	M 8×1.25	2.5±0.5	18.1±3.6

Item	Size	kgf · m	lbf · ft
3	M10×1.5	6.9±1.4	49.9±10.1
-	-	-	-

GROUP 4 HYDRAULIC SYSTEM

HYDRAULIC COMPONENTS MOUNTING 1

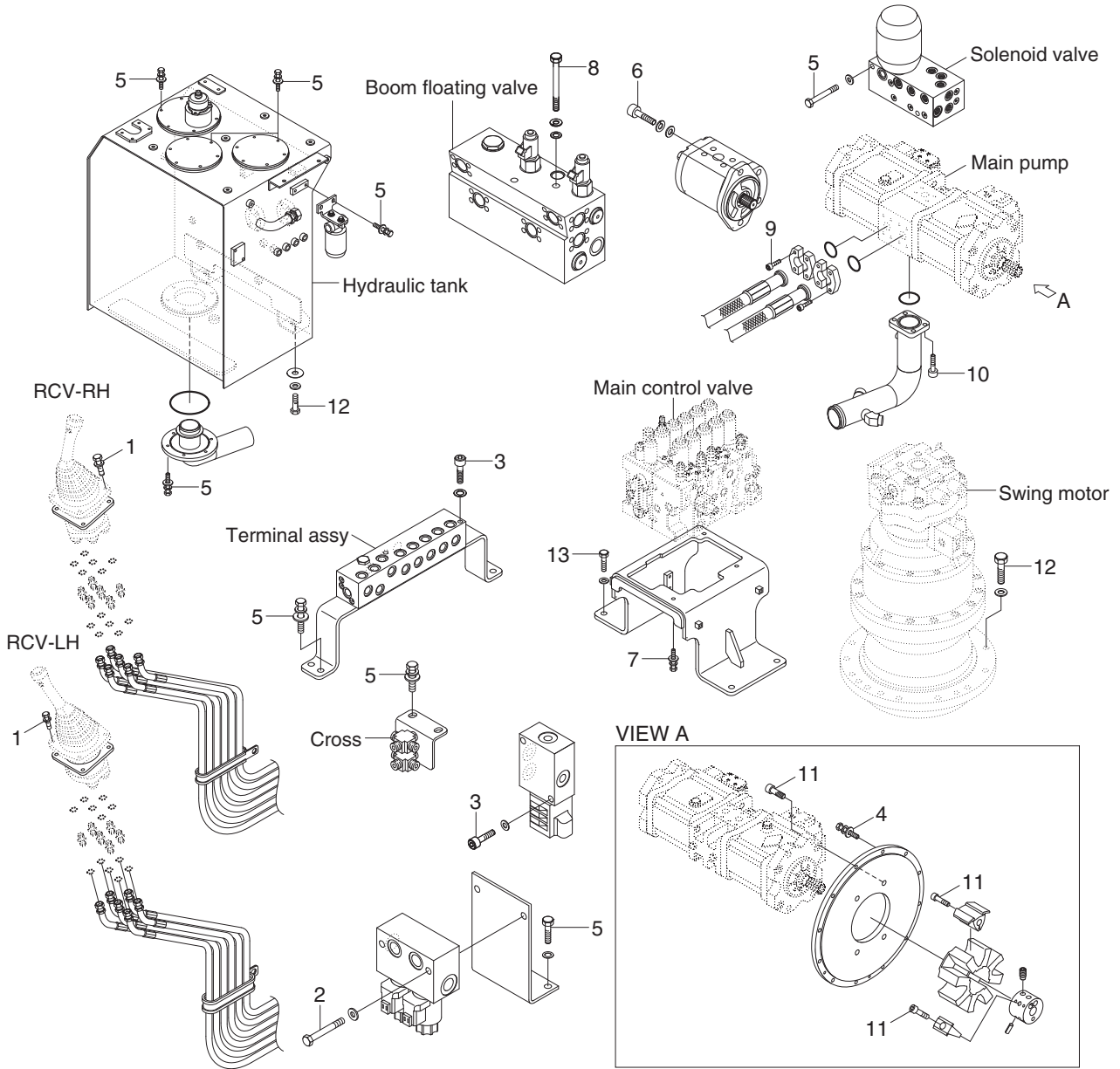

330L9CM05

· Tightening torque

Item	Size	kgf · m	lbf · ft
1	M 6×1.0	1.05±0.2	7.6±1.45
2	M 8×1.25	2.5±0.5	18.1±3.6
3	M 8×1.25	4.05±0.8	29.3±5.8
4	M10×1.5	4.8±0.3	34.7±2.2
5	M10×1.5	6.9±1.4	49.9±10.1
6	M10×1.5	8.27±1.7	59.8±12.3
7	M12×1.75	12.2±1.3	88.2±9.4

Item	Size	kgf · m	lbf · ft
8	M12×1.75	12.8±3.0	92.6±21.7
9	M12×1.75	14.7±2.2	106±15.9
10	M16×2.0	35.6±7.1	257±51
11	M20×2.5	46.5±2.5	336±18.1
12	M20×2.5	57.9±5.8	419±42
13	M20×2.5	57.9±8.7	419±62.9
-	-	-	-

HYDRAULIC COMPONENTS MOUNTING 2

ATTACH PIPING

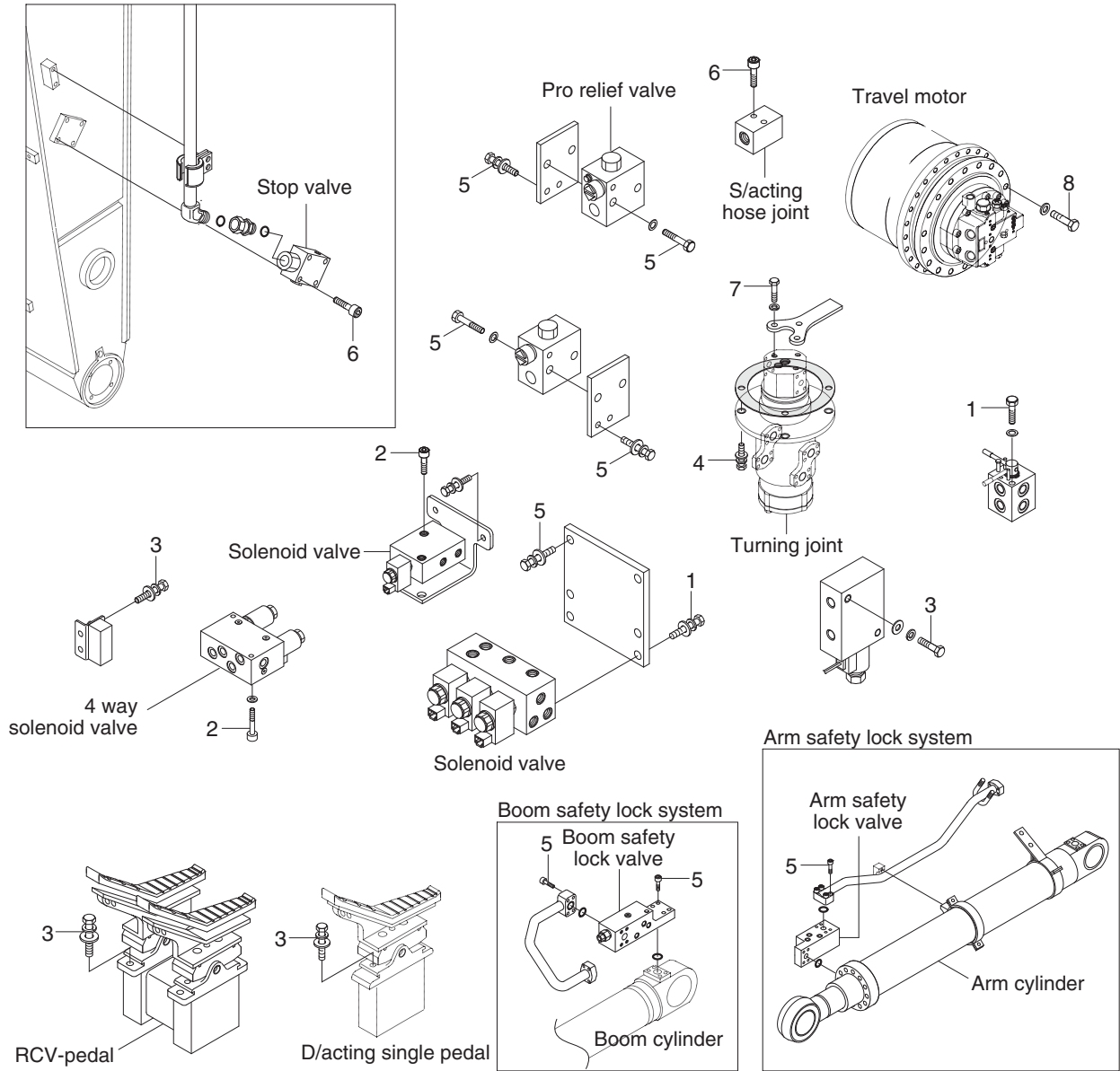

330L9CM06

· Tightening torque

Item	Size	kgf · m	lbf · ft
1	M 8×1.25	2.5±0.5	18.1±3.6
2	M 8×1.25	4.05±0.8	29.3±5.8
3	M10×1.5	6.9±1.4	49.9±10.1
4	M12×1.75	12.3±1.3	89.0±9.4

Item	Size	kgf · m	lbf · ft
5	M12×1.75	12.8±3.0	92.6±21.7
6	M12×1.75	14.7±2.2	106±15.9
7	M14×2.0	19.6±2.9	142±21.0
8	M24×3.0	84±8.0	608±57.8

HYDRAULIC COMPONENTS MOUNTING 3

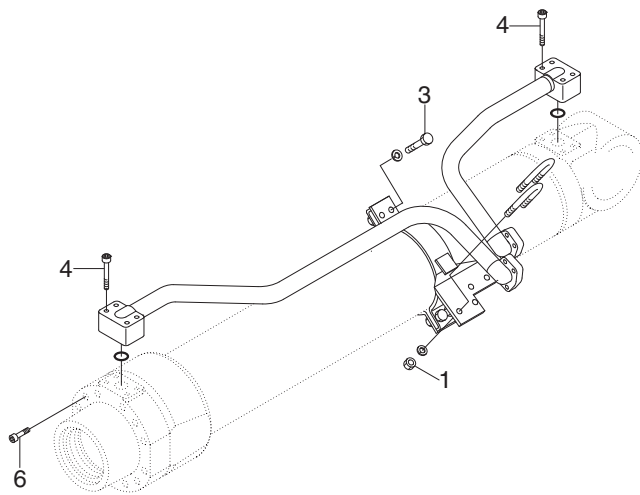

BOOM CYLINDER

Solenoid valve

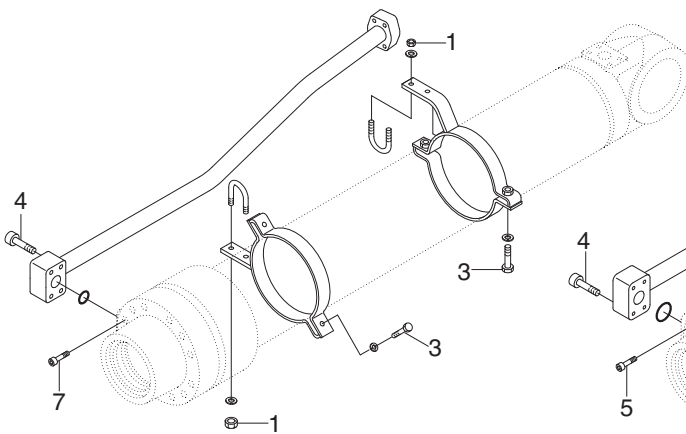
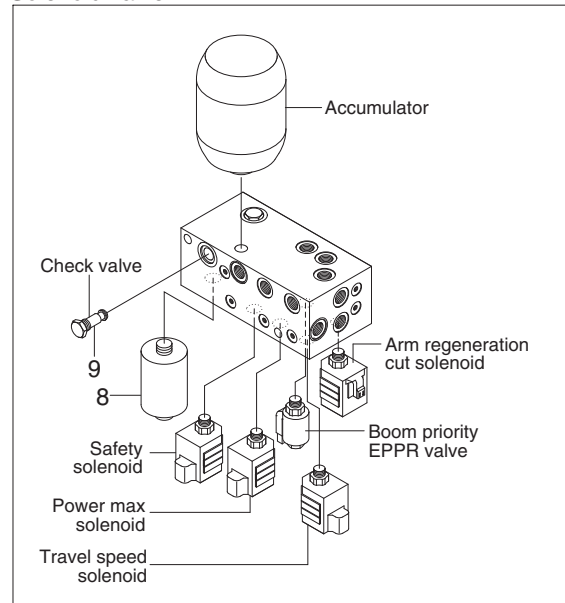

ARM CYLINDER

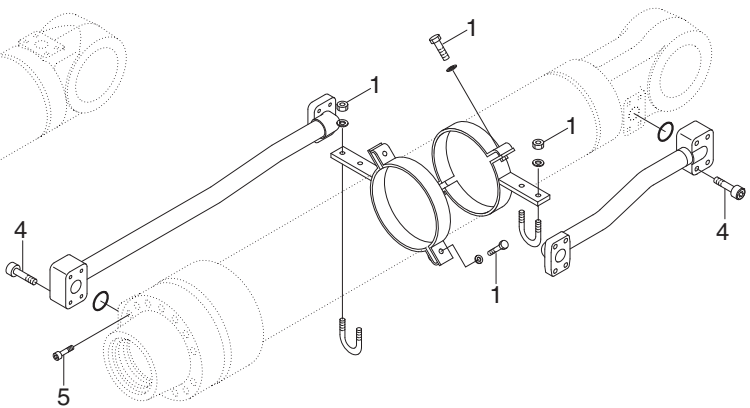

BUCKET CYLINDER

3309A9CM07

· Tightening torque

Item	Size	kgf · m	lbf · ft
1	M10×1.5	3.2±0.3	23.1±2.2
3	M12×1.75	5.5±0.6	39.8±4.3
4	M12×1.75	9.4±1.0	68.0±7.2
5	M18×2.5	32±3.0	232±21.7

Item	Size	kgf · m	lbf · ft
6	M20×2.5	46±5.0	333±36.2
7	M22×2.5	63±6.0	456±43.4
8	Line filter	2.5	18.0
9	Check valve	4.0	28.9

GROUP 5 UNDERCARRIAGE

UNDERCARRIAGE MOUNTING

ADJUST COMPONENT

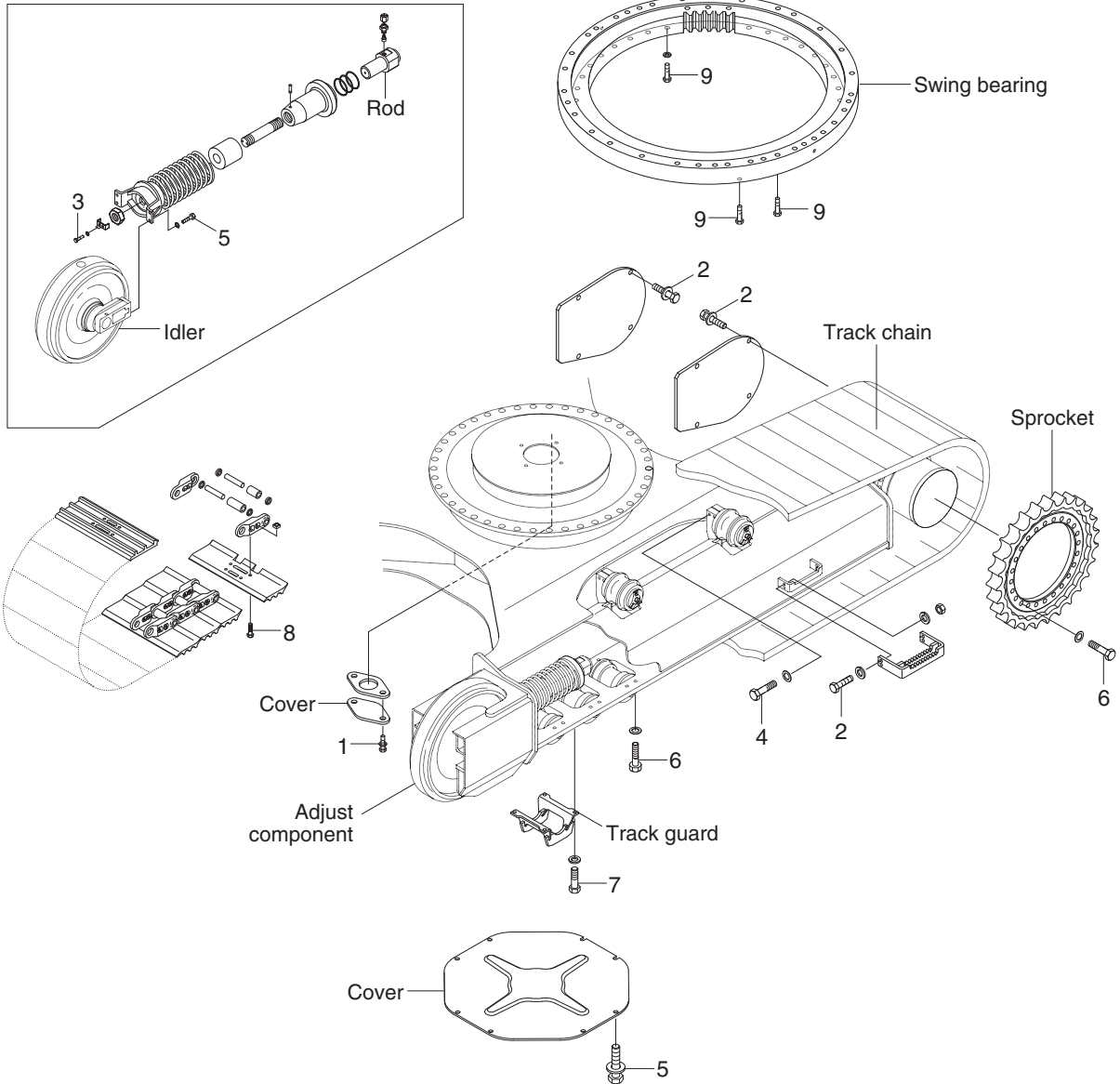

330L9CM08

· Tightening torque

Item	Size	kgf · m	lbf · ft
1	M10×1.5	6.9±1.4	49.9±10.1
2	M12×1.75	12.8±3.0	92.6±21.7
3	M12×1.25	13.3±2.7	96.2±19.5
4	M16×2.0	29.7±3.0	215±21.7
5	M16×2.0	29.7±4.5	215±32.5

Item	Size	kgf · m	lbf · ft
6	M20×2.5	57.9±6.0	419±43.4
7	M20×2.5	57.9±8.7	419±62.9
8	M22×1.5	123±6.0	890±43.4
9	M24×3.0	100±10	723±72.3
-	-	-	-

UNDERCARRIAGE MOUNTING (HIGH WALKER)

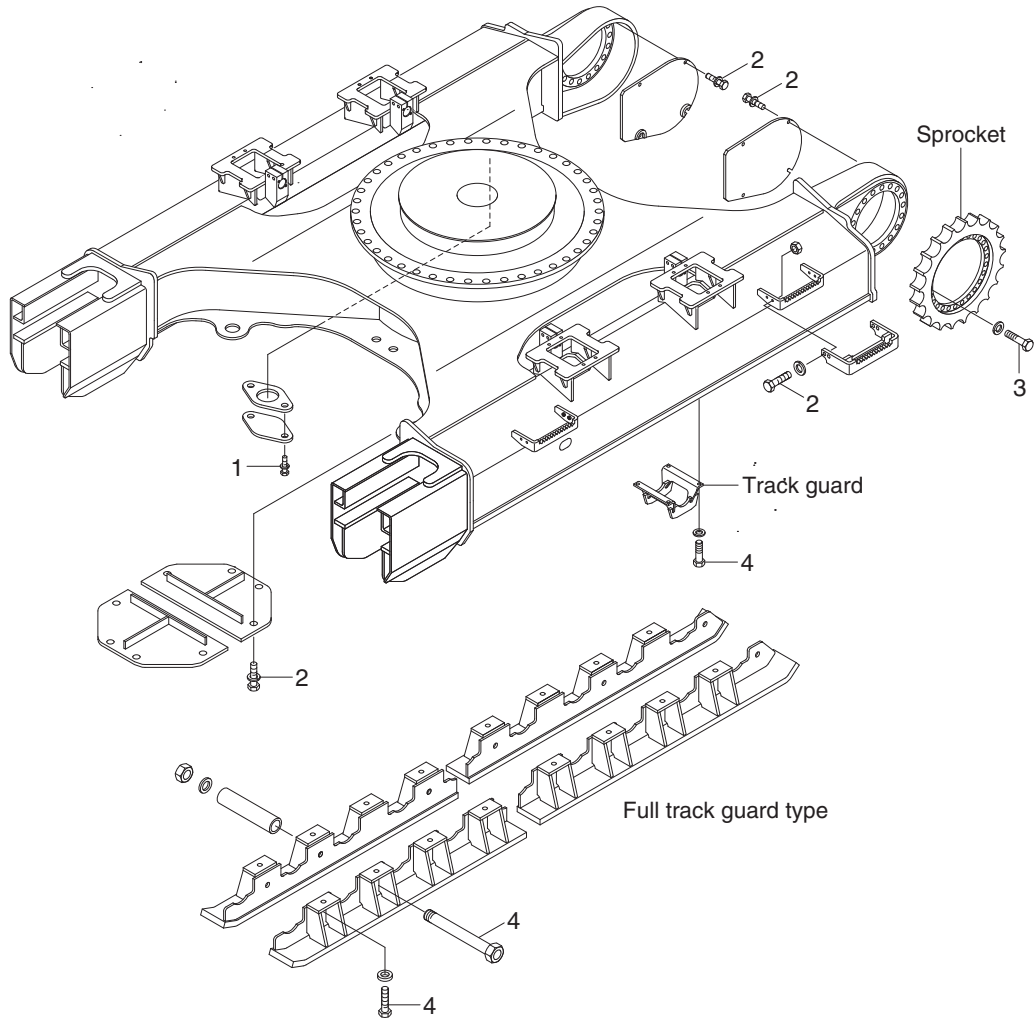

330L9CM09

· Tightening torque

Item	Size	kgf · m	lbf · ft
1	M10×1.5	6.9±1.4	49.9±10.1
2	M12×1.75	12.8±3.0	92.6±21.7

Item	Size	kgf · m	lbf · ft
3	M20×2.5	57.9±6.0	419±43.3
4	M24×3.0	100±15	723±109

GROUP 6 STRUCTURE

CAB AND ACCESSORIES MOUNTING

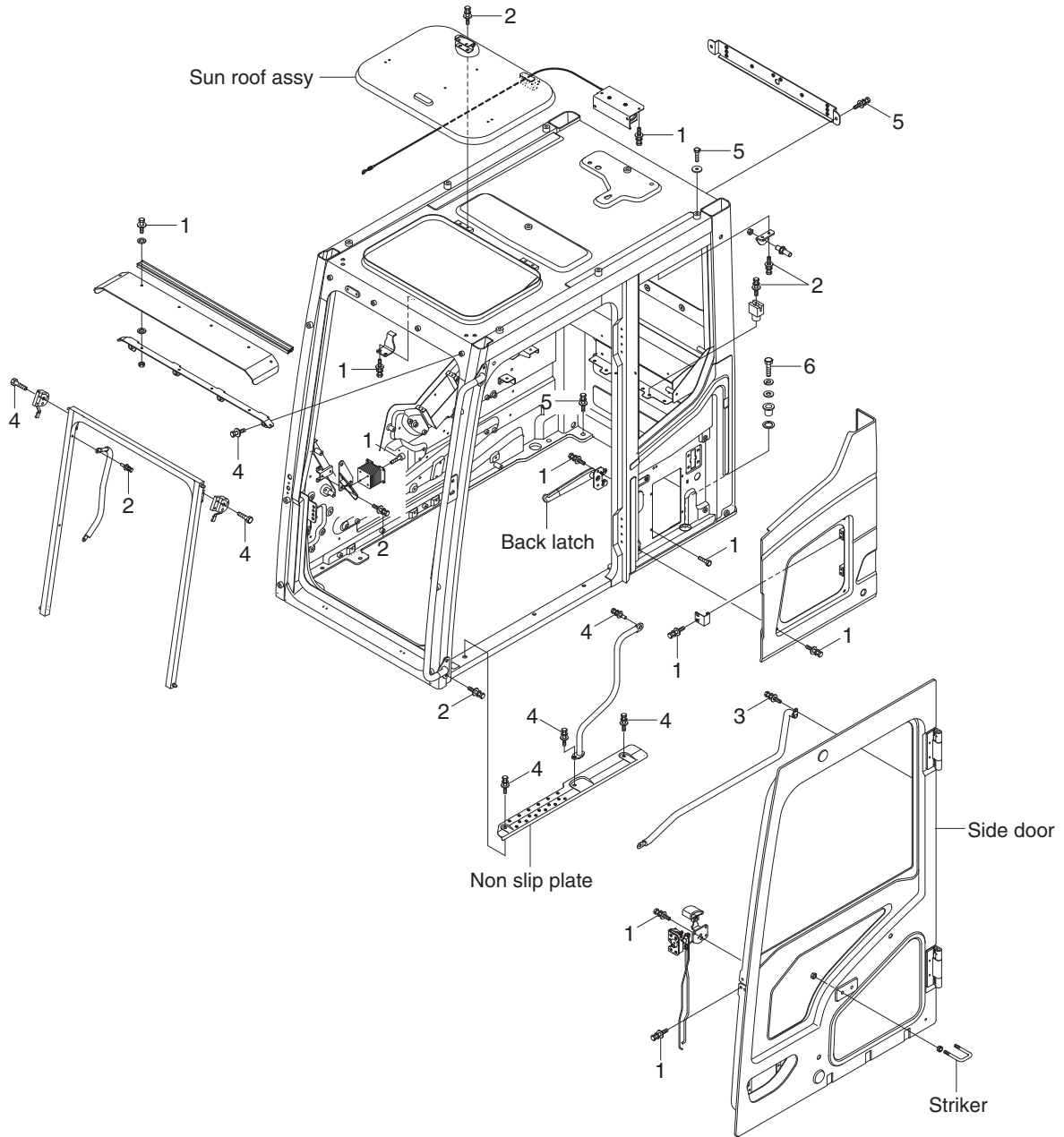

330L9CM10

· Tightening torque

Item	Size	kgf · m	lbf · ft
1	M 6×1.0	1.05±0.2	7.6±1.45
2	M 8×1.25	2.5±0.5	18.1±3.6
3	M 8×1.25	3.43±0.7	24.8±5.1

Item	Size	kgf · m	lbf · ft
4	M10×1.5	6.9±1.4	49.9±10.1
5	M12×1.75	12.8±3.0	92.6±21.7
6	M24×3.0	100±15	723±109

CAB INTERIOR MOUNTING

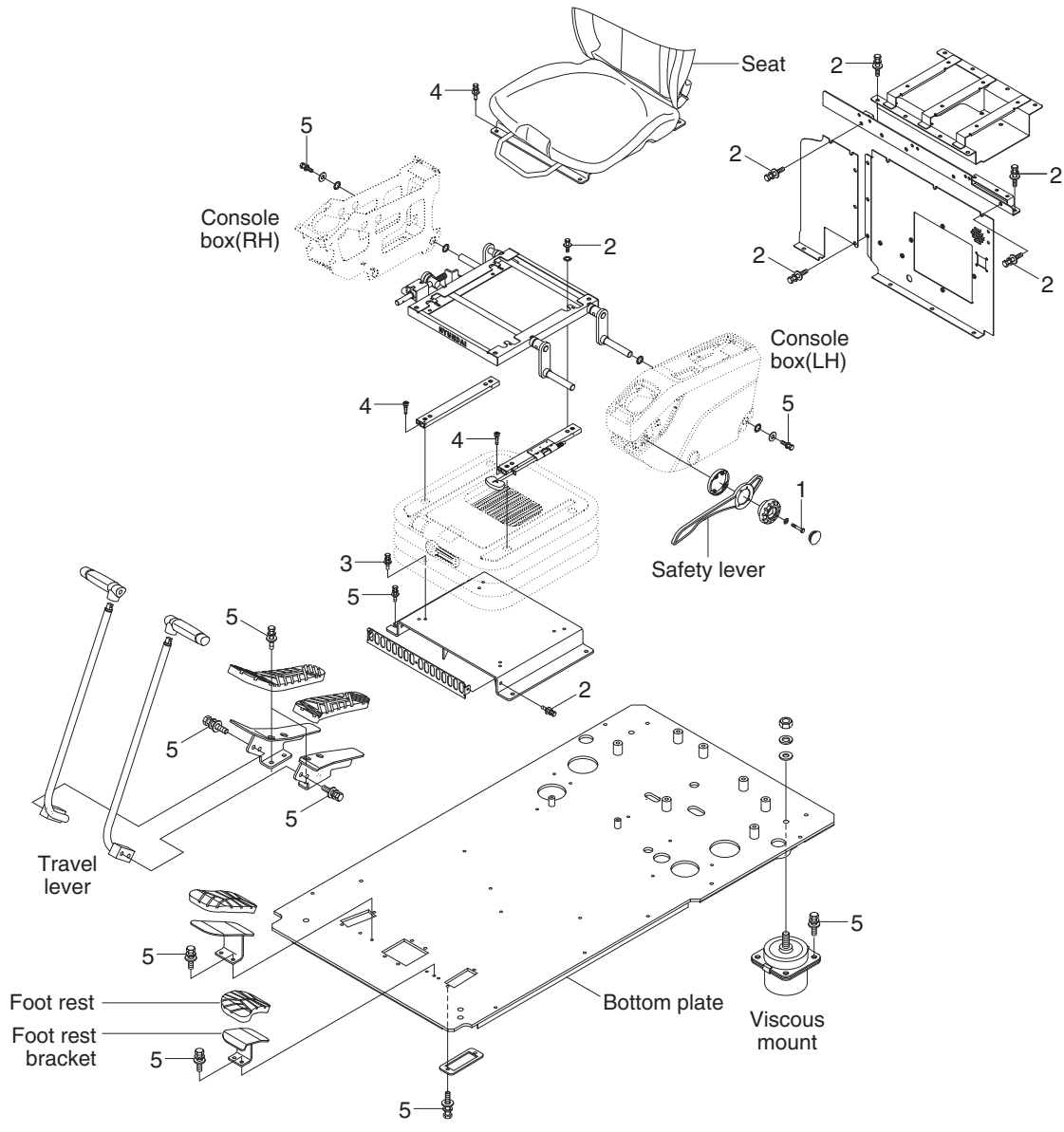

330L9CM11

· Tightening torque

Item	Size	kgf · m	lbf · ft
1	M 6×1.0	1.05±0.2	7.6±1.45
2	M 8×1.25	2.5±0.5	18.1±3.6
3	M 8×1.25	3.43±0.7	24.8±5.1

Item	Size	kgf · m	lbf · ft
4	M 8×1.25	4.05±0.8	29.3±5.8
5	M10×1.5	6.9±1.4	49.9±10.1
-	-	-	-

COWLING MOUNTING

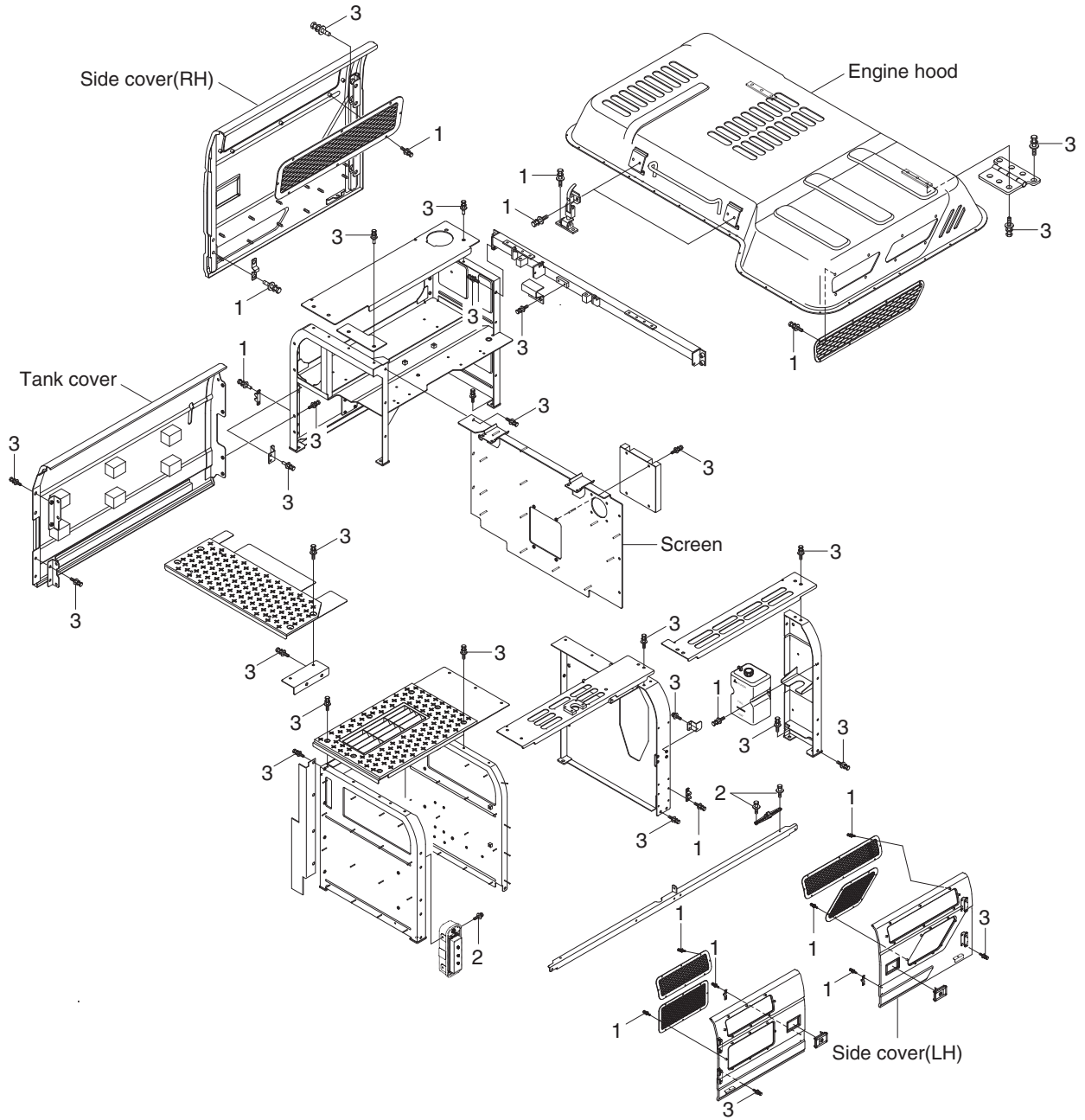

330L9CM12

· Tightening torque

Item	Size	kgf · m	lbf · ft
1	M 8×1.25	2.5±0.5	18.1±3.6
2	M10×1.5	6.9±1.4	49.9±10.1

Item	Size	kgf · m	lbf · ft
3	M12×1.75	12.8±3.0	92.6±21.7
-	-	-	-

COUNTERWEIGHT AND COVERS MOUNTING

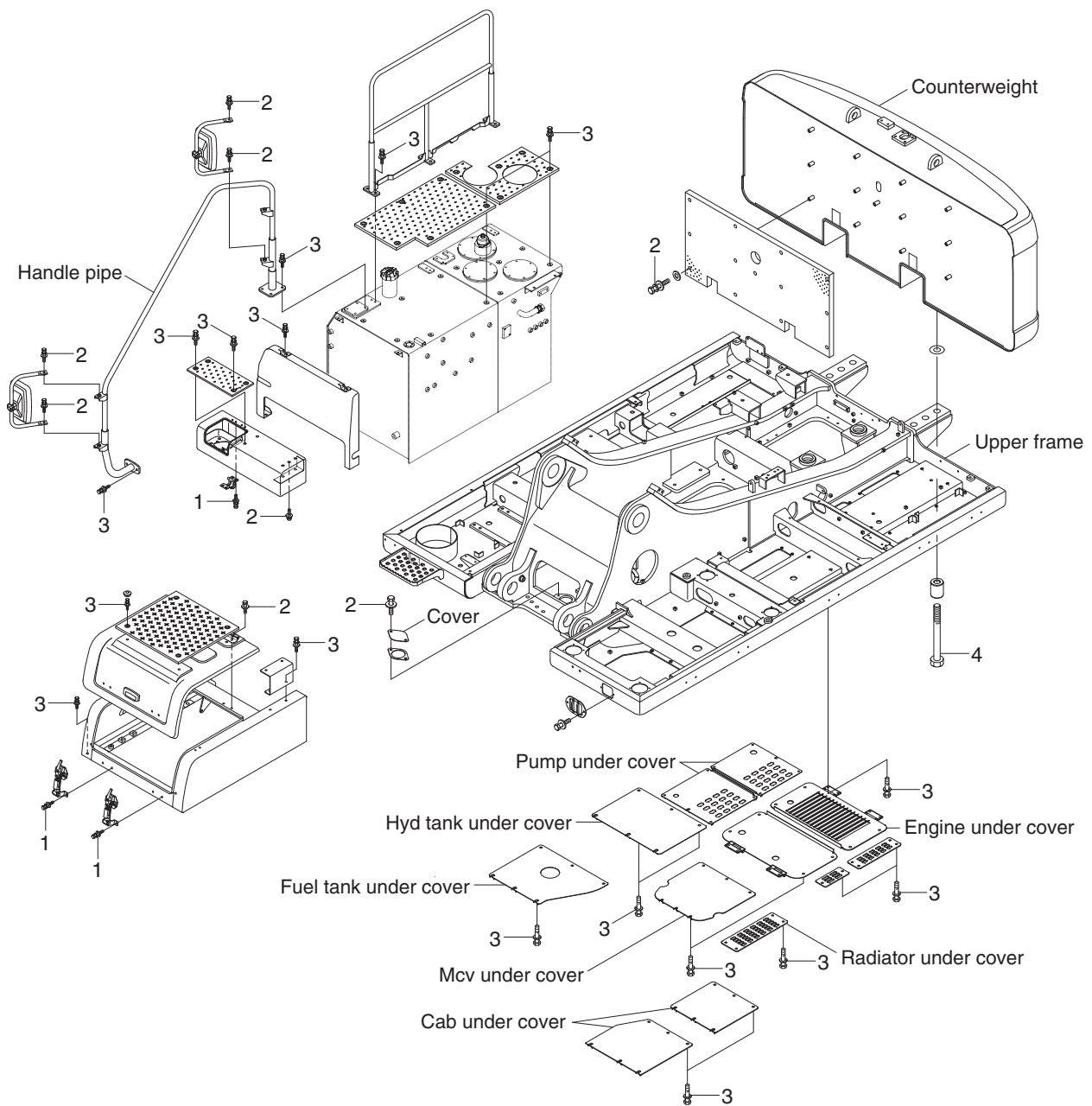

330L9CM13

· Tightening torque

Item	Size	kgf · m	lbf · ft
1	M 8×1.25	2.5±0.5	18.1±3.6
2	M10×1.5	6.9±1.4	49.9±10.1

Item	Size	kgf · m	lbf · ft
3	M12×1.75	12.8±3.0	92.6±21.7
4	M36×3.0	337±30	2440±217

GROUP 7 WORK EQUIPMENT

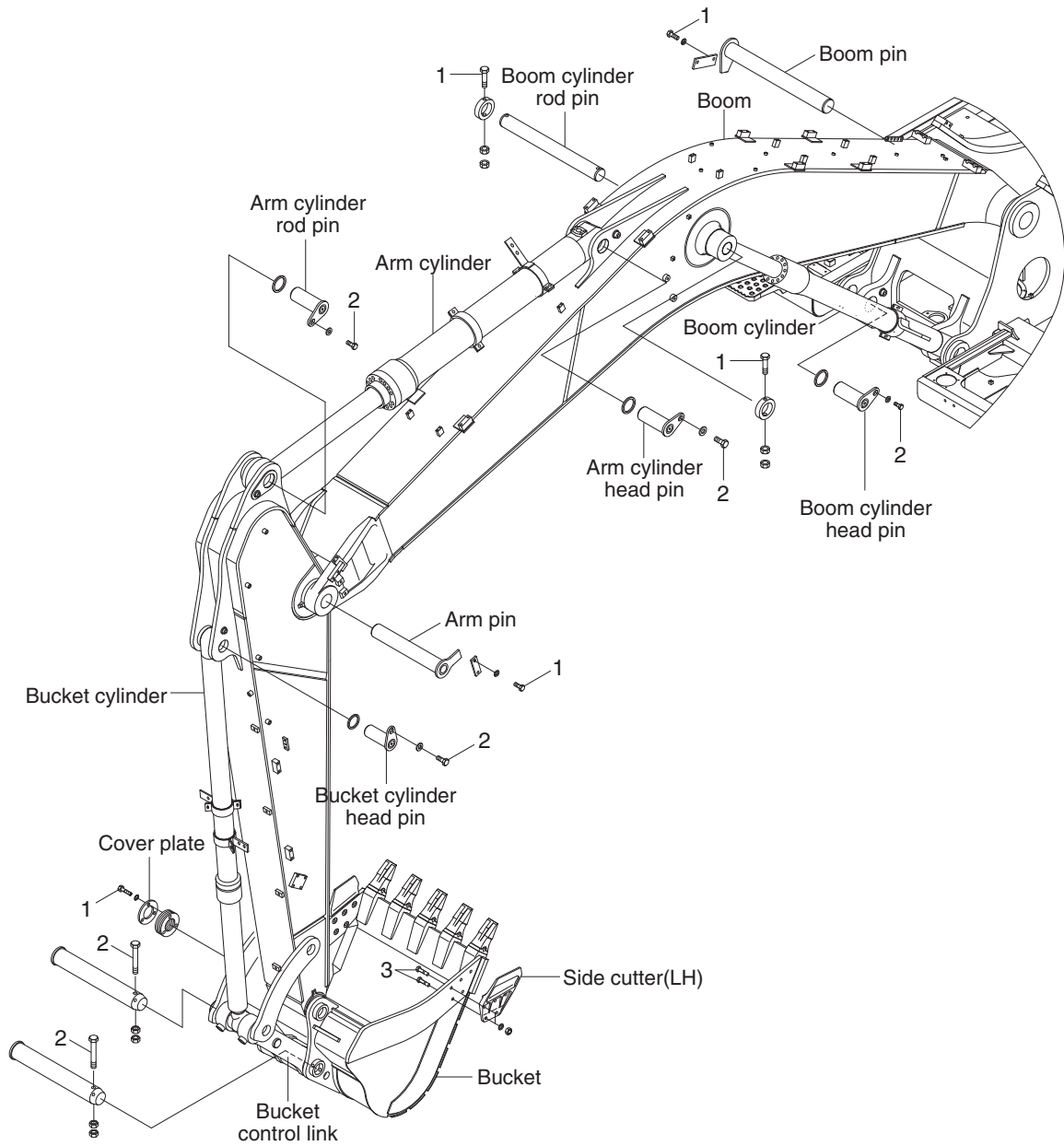

330L9CM14

· Tightening torque

Item	Size	kgf · m	lbf · ft
1	M16×2.0	29.7±4.5	215±32.5
2	M20×2.5	57.9±8.7	419±62.9

Item	Size	kgf · m	lbf · ft
3	M22×2.5	81.9±16.1	592±116
-	-	-	-