

SECTION 4 ELECTRICAL SYSTEM

Group 1 Component Location	4-1
Group 2 Electrical Circuit	4-3
Group 3 Electrical Component Specification	4-23
Group 4 Connectors	4-36

GROUP 1 COMPONENT LOCATION

1. LOCATION 1

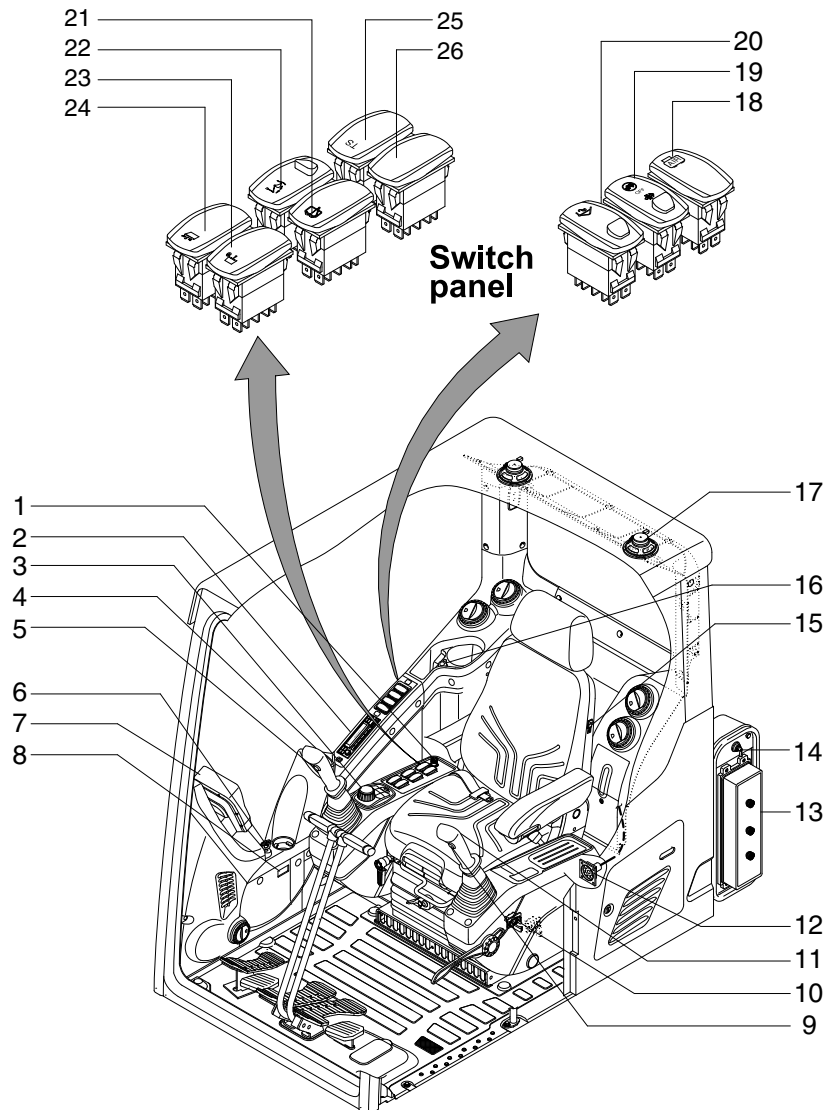

220A4EL01

- | | | |
|----------------------------|---------------------------------|--------------------------------|
| 1 Cigar lighter | 10 Emergency engine stop switch | 19 SCR system cleaning switch |
| 2 Radio & USB player | 11 One touch decel switch | 20 Quick coupler switch |
| 3 Jog dial module | 12 RS232 & J1939 service socket | 21 Lower wiper & washer switch |
| 4 Horn switch | 13 Fuse & relay box | 22 Boom floating switch |
| 5 Breaker operation switch | 14 Master switch | 23 Swing lock switch |
| 6 Starting switch | 15 Seat heater switch | 24 Free/fine swing switch |
| 7 Cluster | 16 Power socket | 25 Travel straight switch |
| 8 Service meter | 17 Speaker | 26 Option attach switch |
| 9 Power max switch | 18 Air compressor switch | |

2. LOCATION 2

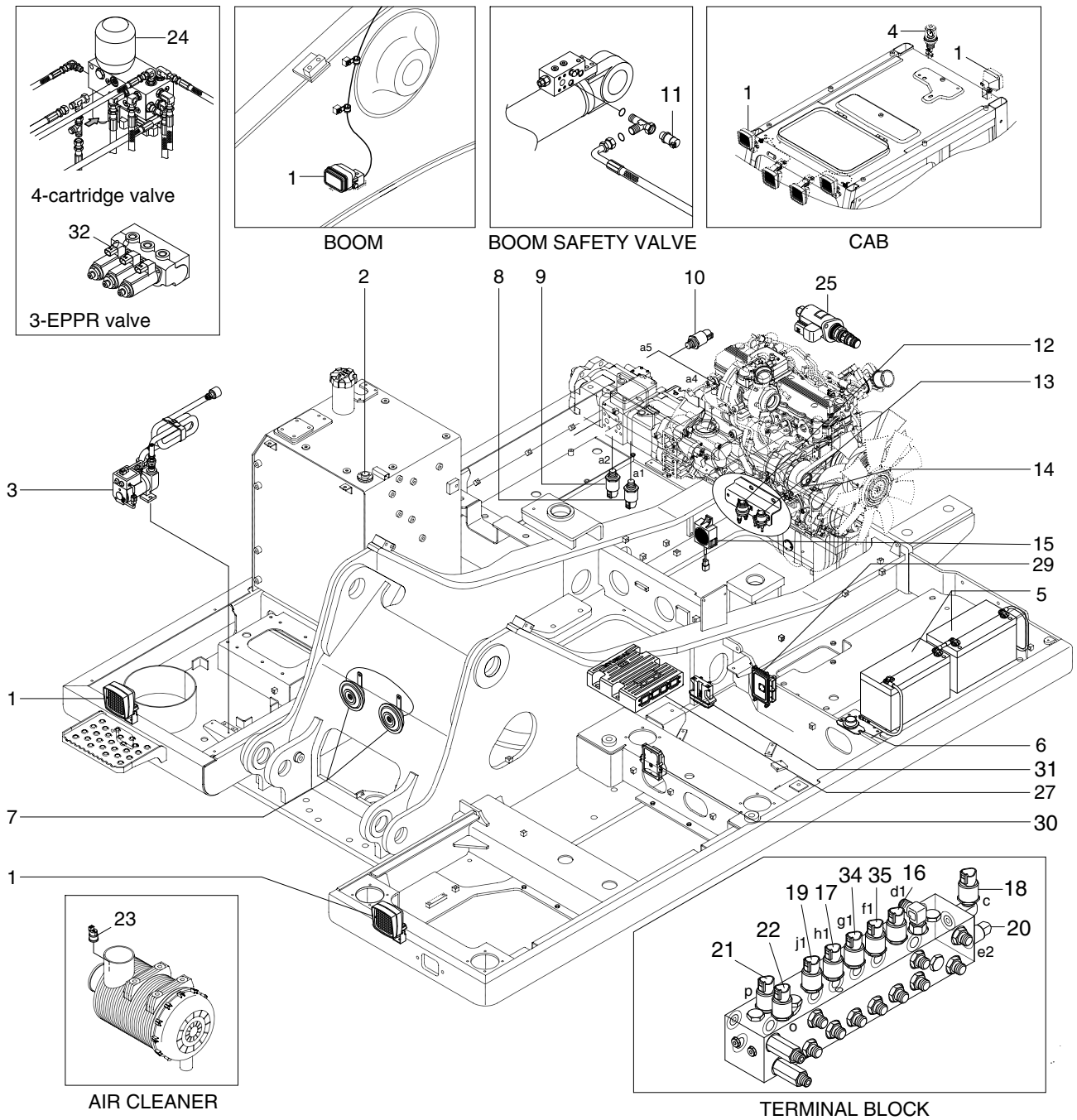

- | | | | | | |
|----|--------------------------|----|---------------------------|----|----------------------------|
| 1 | Lamp | 12 | Start relay | 23 | Air cleaner sensor |
| 2 | Fuel sender | 13 | Heater relay | 24 | 4-cartridge valve |
| 3 | Fuel filler pump | 14 | Alternator | 25 | Pump EPPR valve |
| 4 | Beacon lamp | 15 | Travel alarm buzzer | 27 | United MCU |
| 5 | Battery | 16 | Arm out pressure sensor | 29 | AAVM controller |
| 6 | Battery relay | 17 | Boom up pressure sensor | 30 | RDU assy |
| 7 | Horn | 18 | Swing pressure sensor | 31 | PVG32 controller |
| 8 | P1 pressure sensor | 19 | Boom down pressure sensor | 32 | 3-EPPR valve |
| 9 | P2 pressure sensor | 20 | Arm in pressure sensor | 34 | Bucket out pressure sensor |
| 10 | EPPR pressure sensor | 21 | RH travel pressure sensor | 35 | Bucket in pressure sensor |
| 11 | Overload pressure sensor | 22 | LH travel pressure sensor | | |

260A4EL02

GROUP 2 ELECTRICAL CIRCUIT

- ELECTRICAL CIRCUIT (1/3)
- MACHINE SERIAL NO. : #0001-

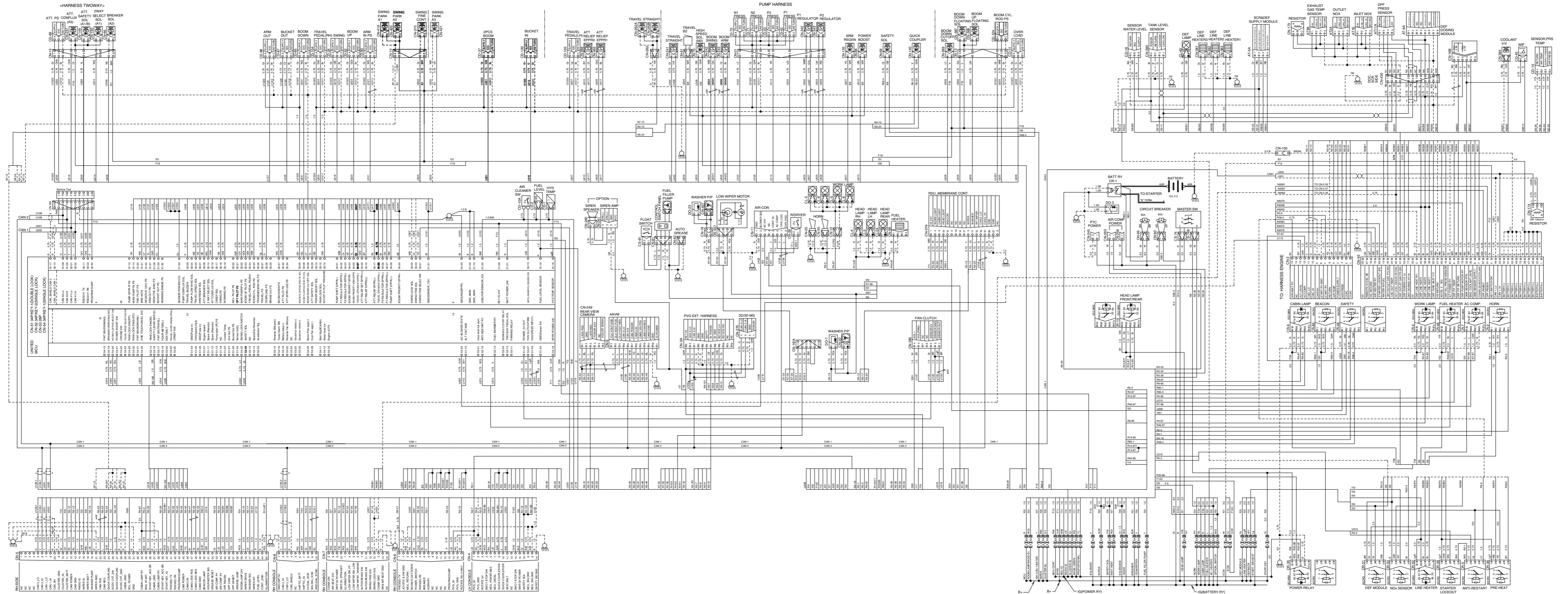

ELECTRICAL CIRCUIT (2/3)

- MACHINE SERIAL NO. : #0041

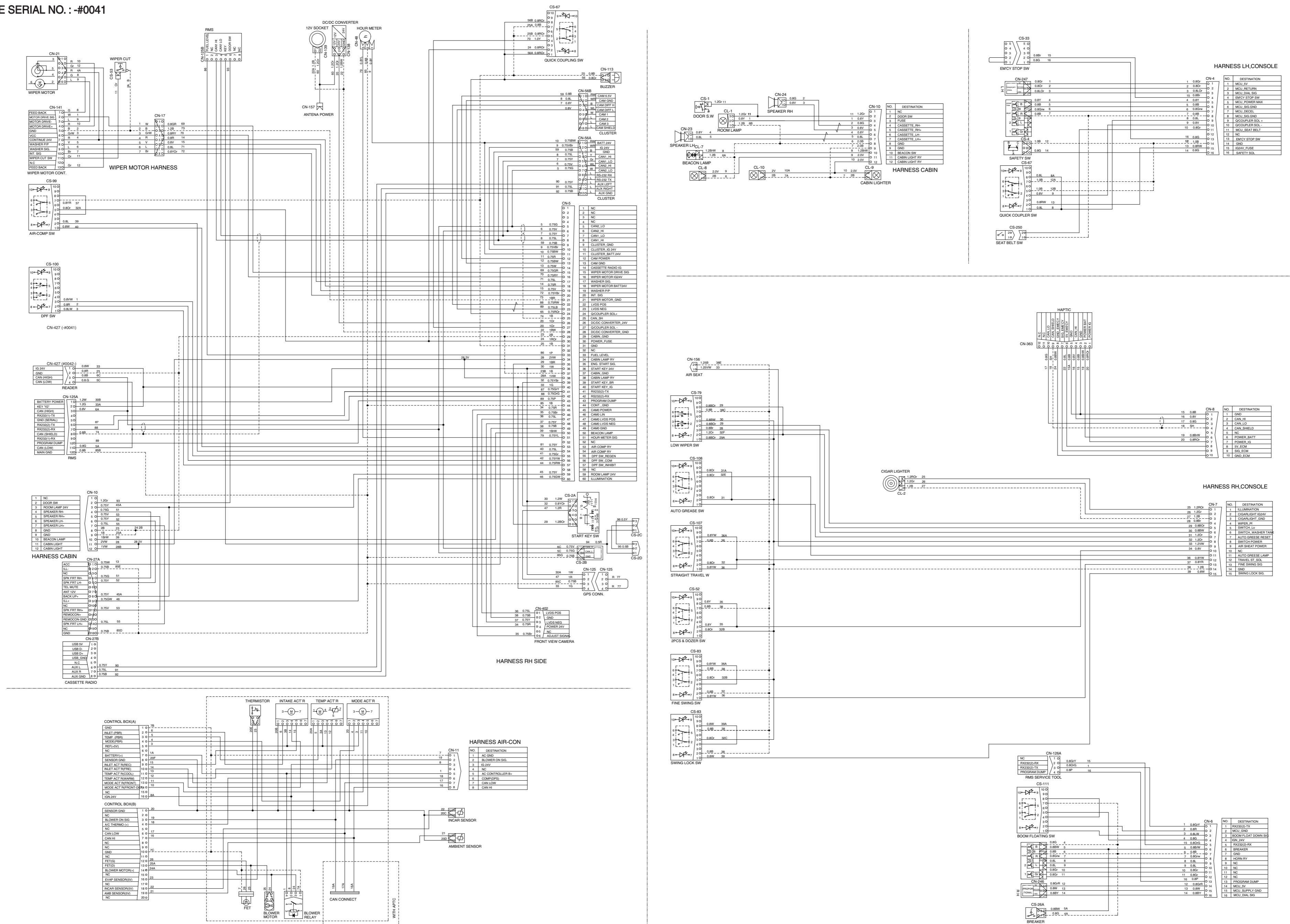

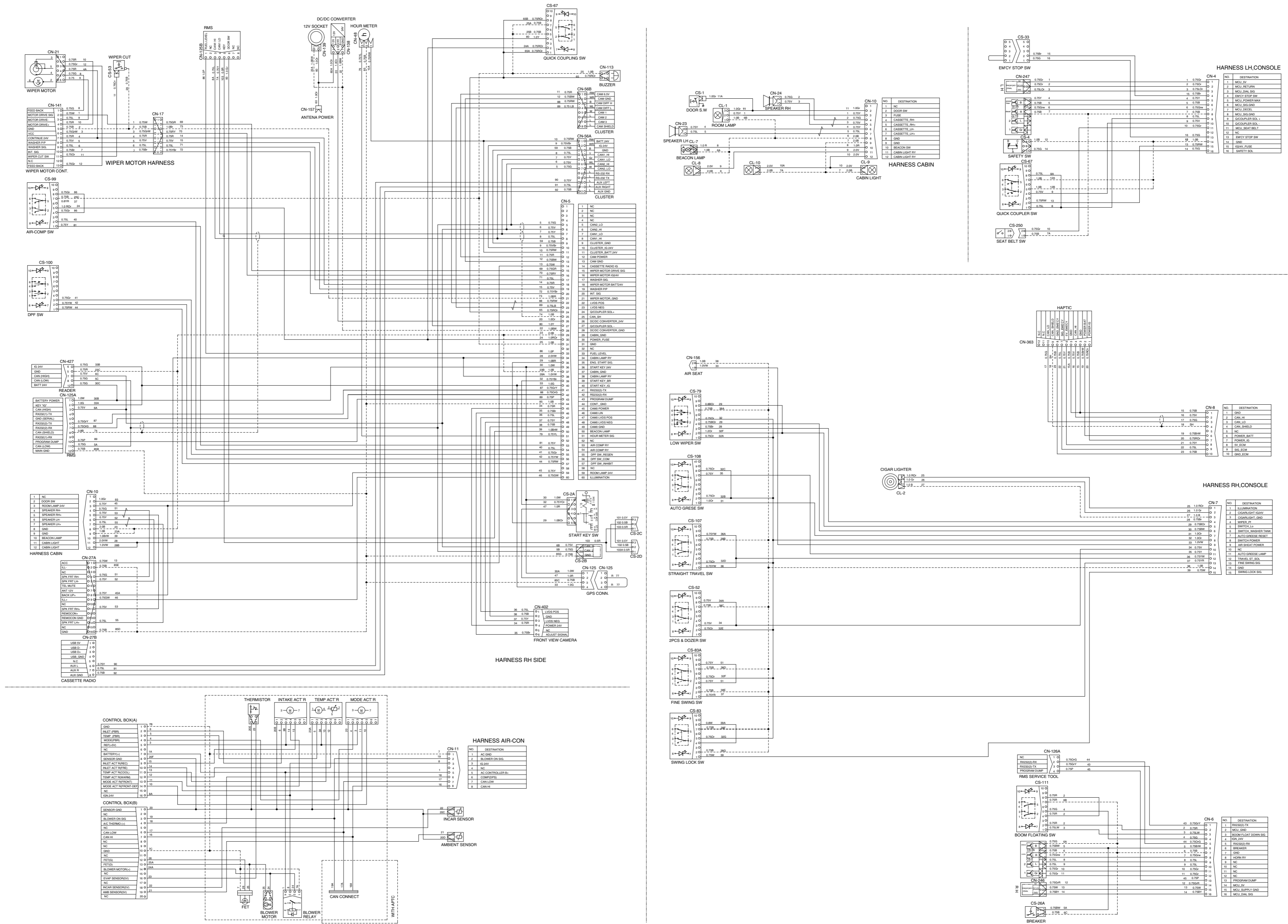

ELECTRICAL CIRCUIT (3/3)

- MACHINE SERIAL NO. : -#0002

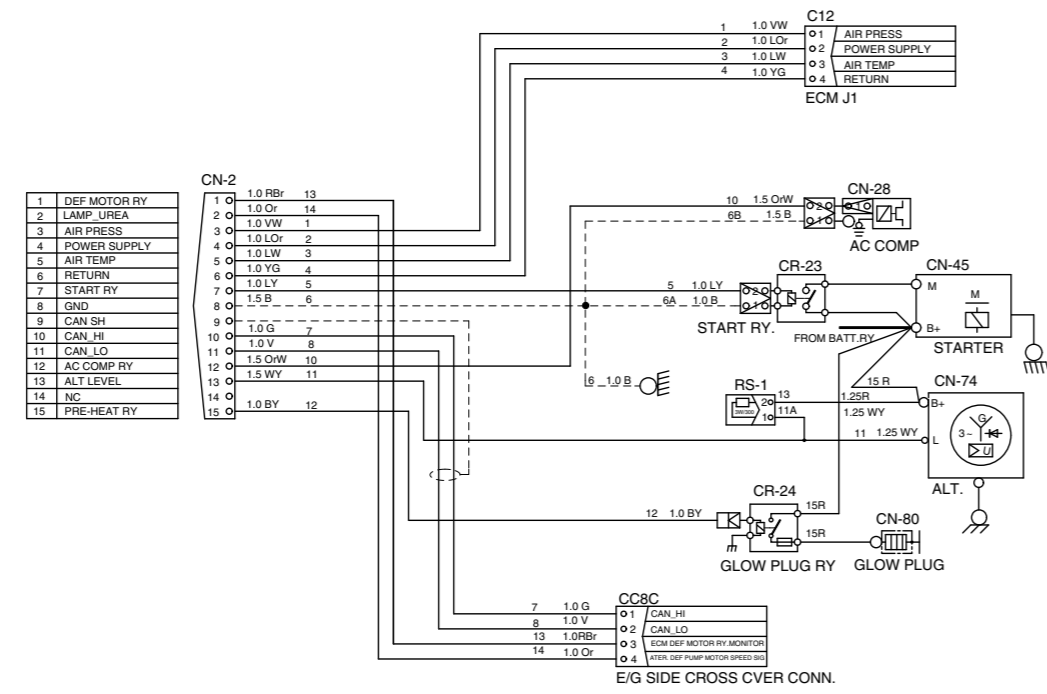

ENGINE HARNESS

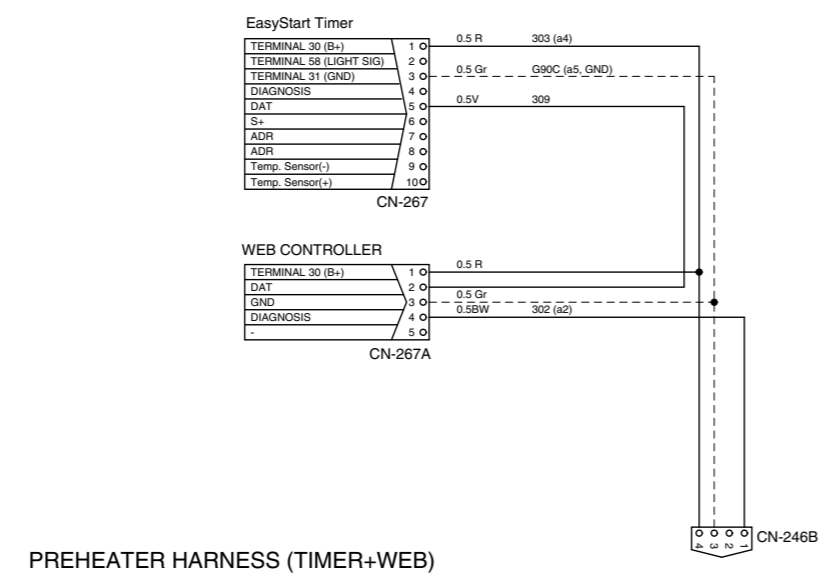

PREHEATER HARNESS (TIMER+WEB)

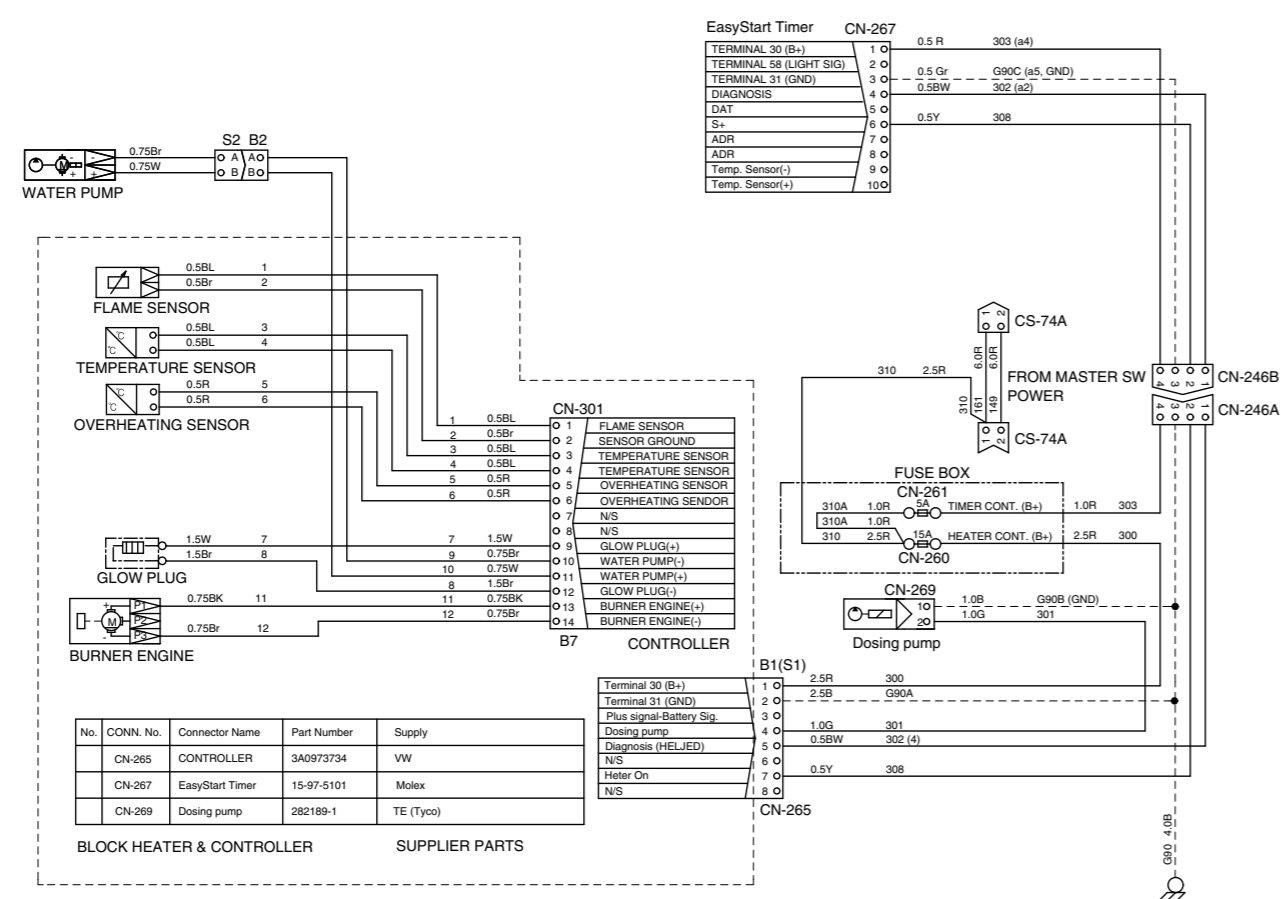

Engine Block Heater

PREHEATER HARNESS (ONLY TIMER)

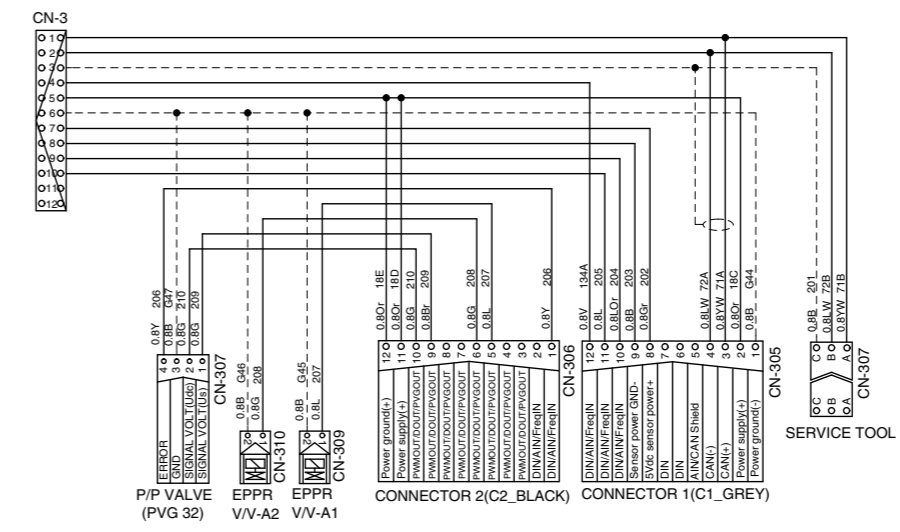

PROPORTIONAL VALVE & LEVER

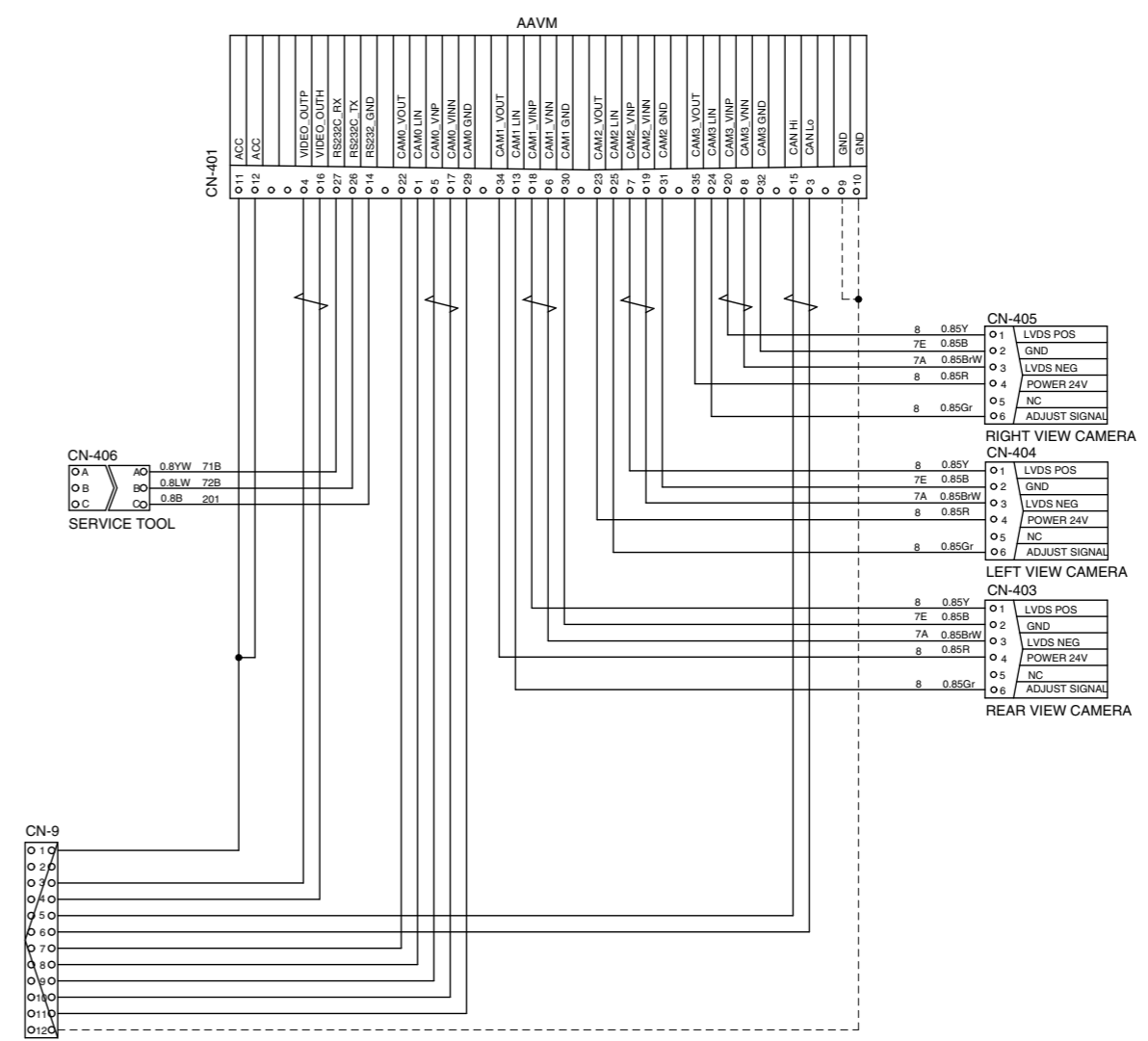

- MACHINE SERIAL NO. : #0003-

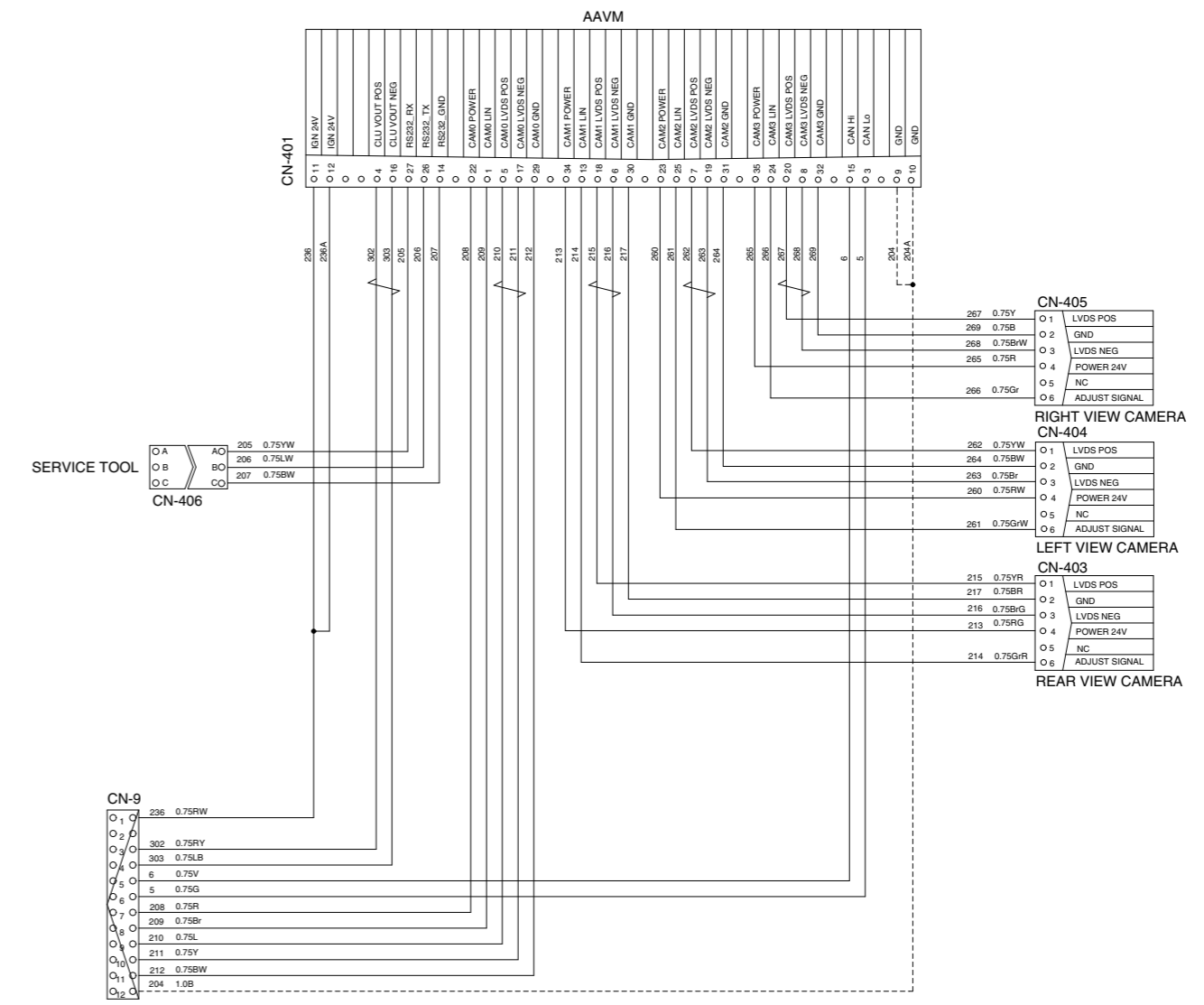
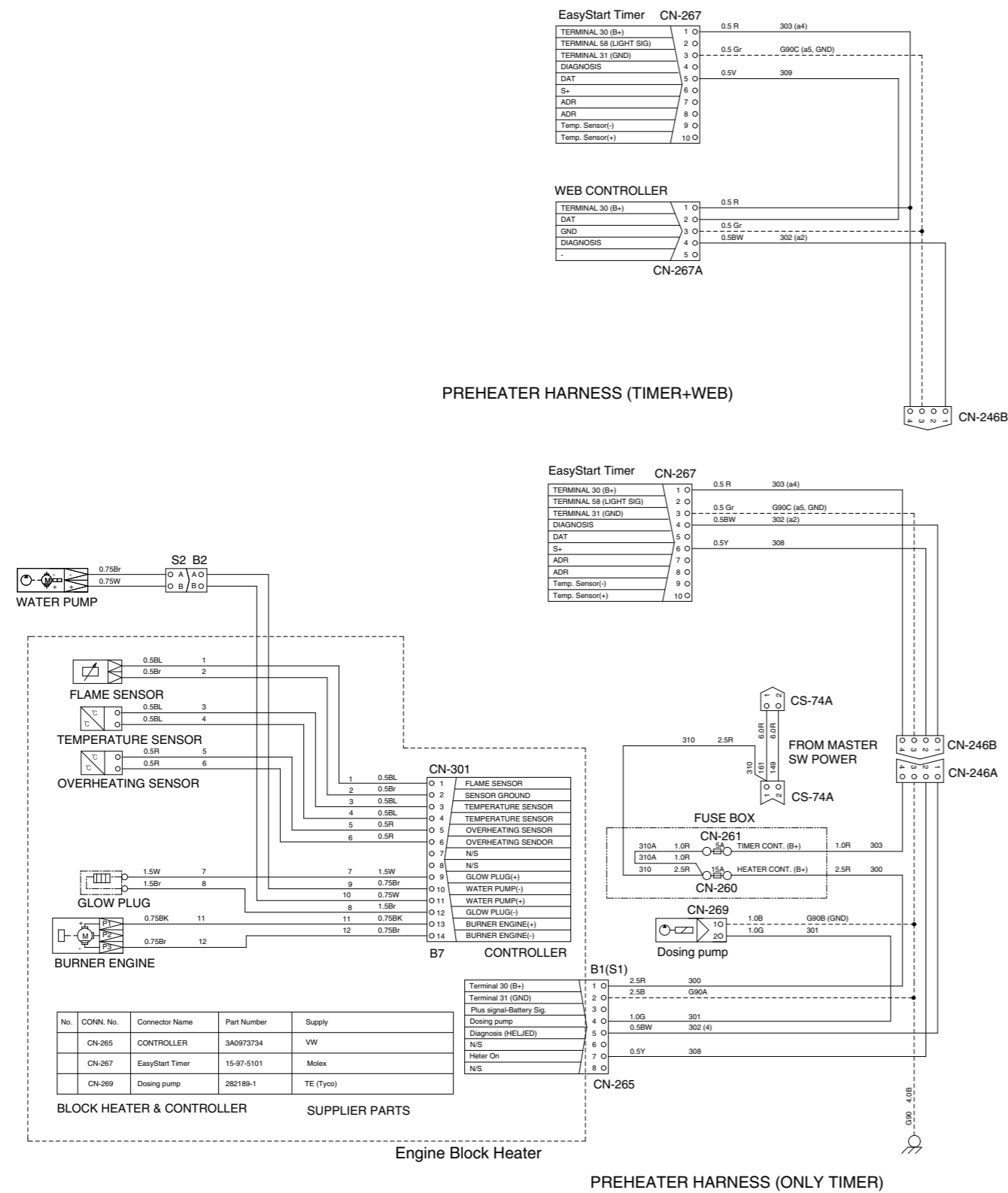
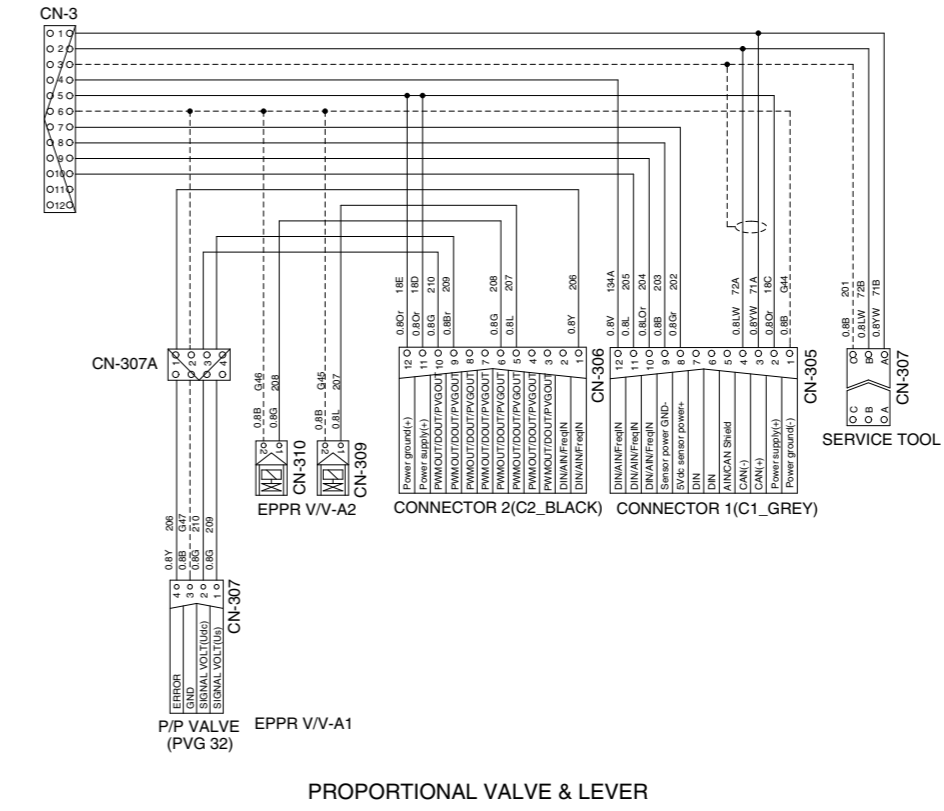
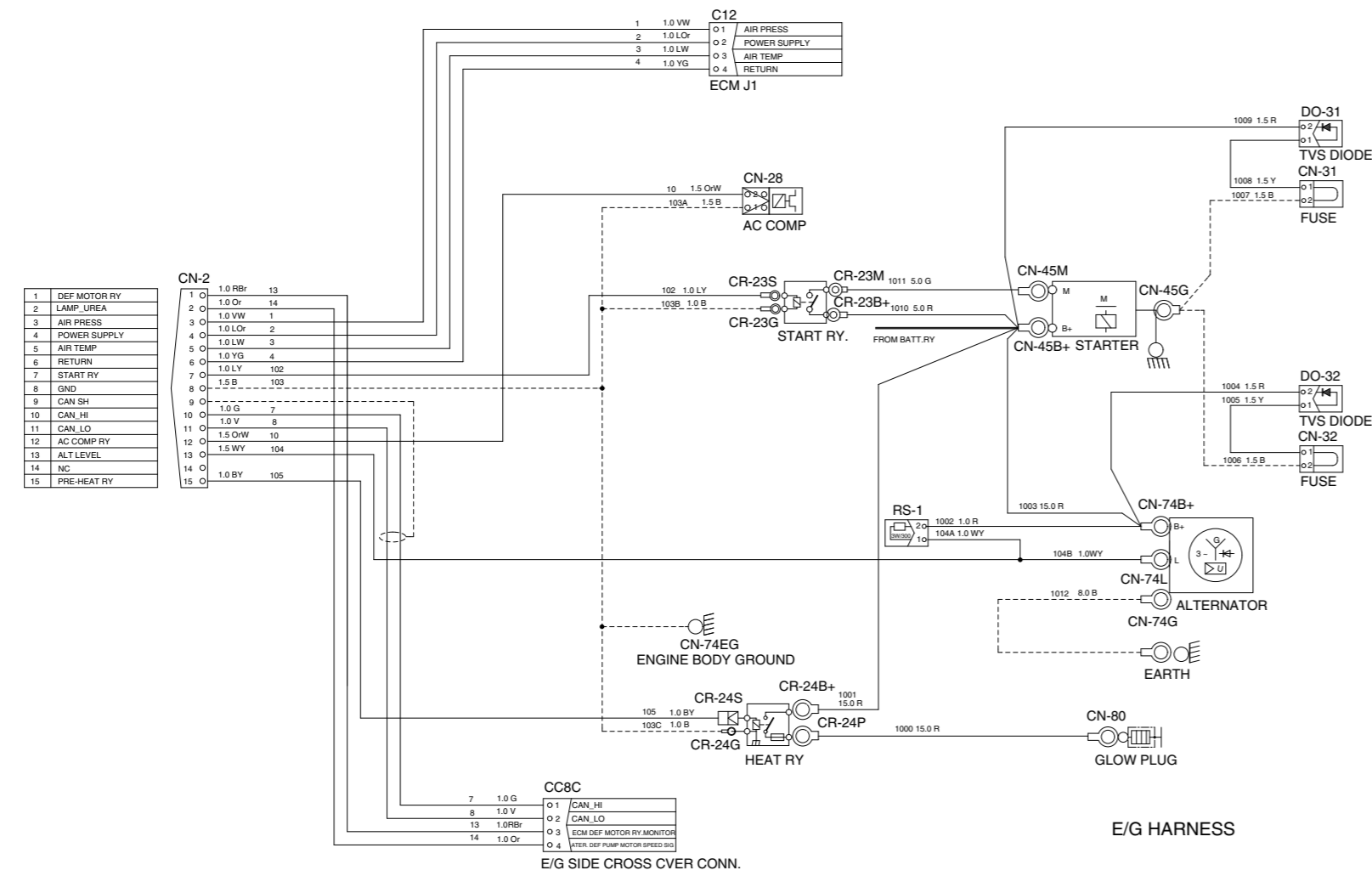

MEMORANDUM

1. POWER CIRCUIT (MACHINE SERIAL NO. : -#0041)

The negative terminal of battery is grounded to the machine chassis directly.

When the start switch is in the OFF position, the current flows from the positive battery terminal as shown below.

1) OPERATING FLOW

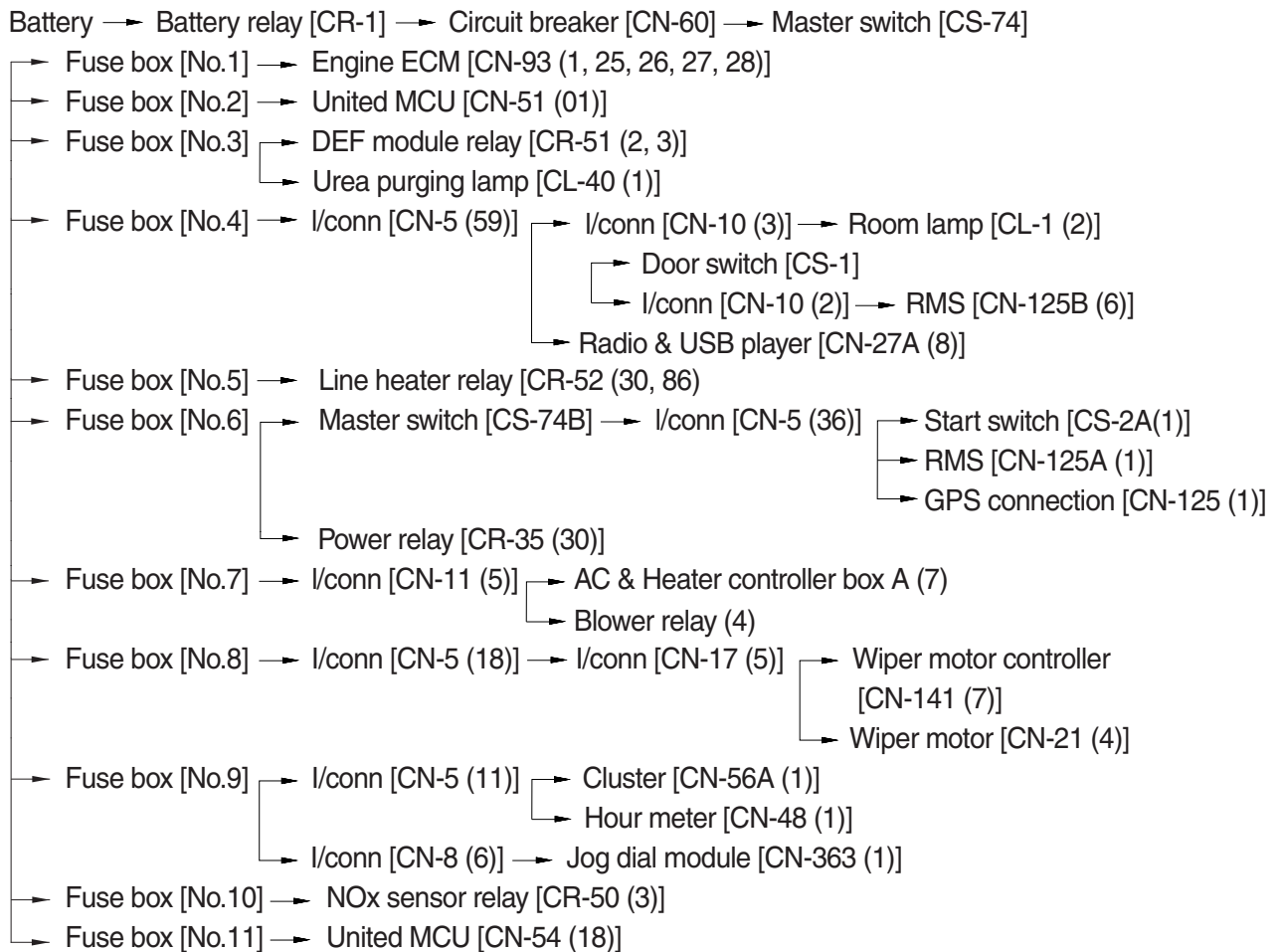

※ I/conn : Intermediate connector

2) CHECK POINT

Engine	Start switch	Check point	Voltage
STOP	OFF	① - GND (battery 1EA)	10~12.5V
		② - GND (battery 2EA)	20~25V
		③ - GND (battery relay)	20~25V
		④ - GND (circuit breaker)	20~25V

※ GND : Ground

POWER CIRCUIT (MACHINE SERIAL NO. : -#0041)

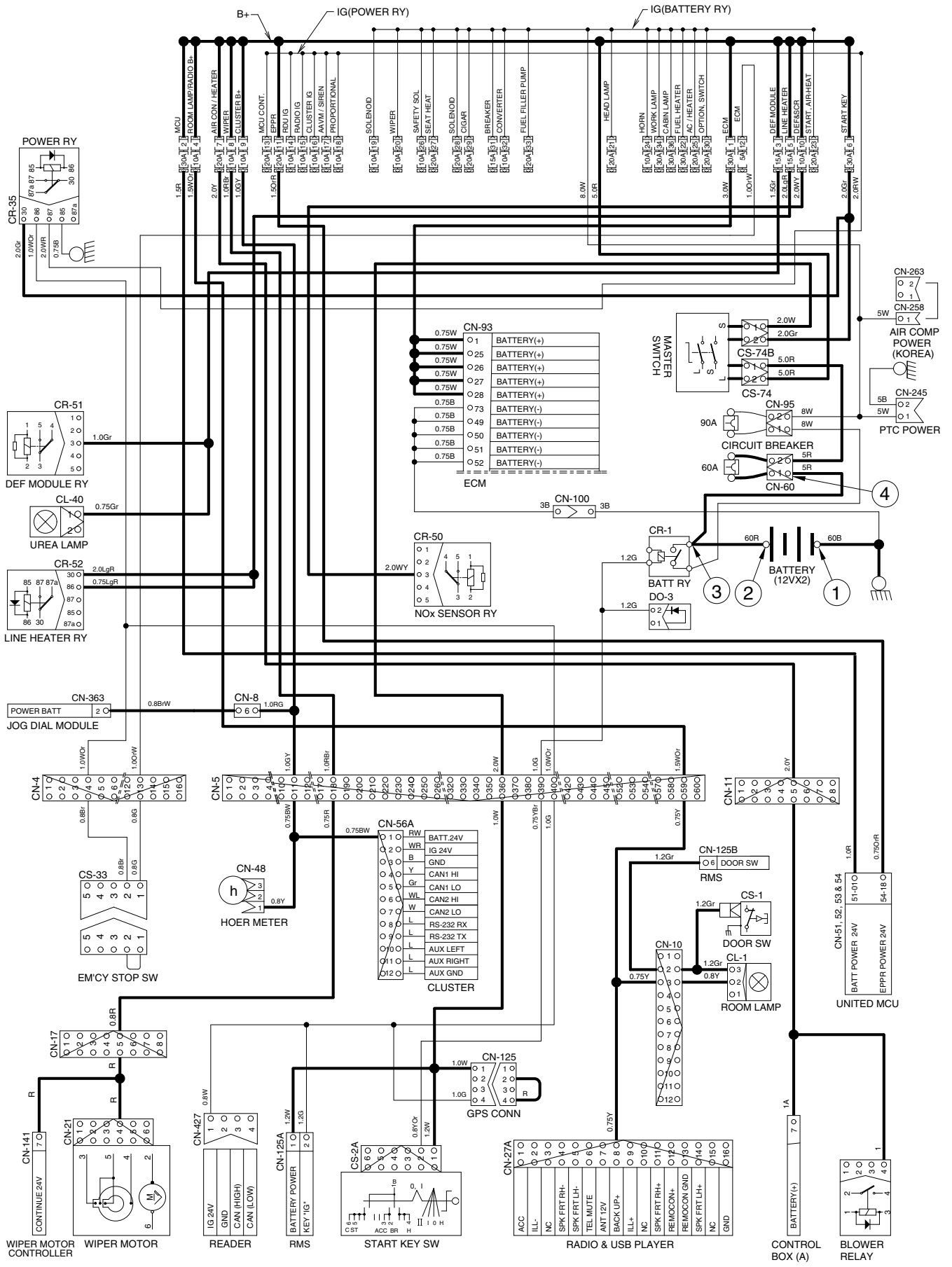

260A4EL05A

POWER CIRCUIT (MACHINE SERIAL NO. : #0042-)

The negative terminal of battery is grounded to the machine chassis directly.

When the start switch is in the OFF position, the current flows from the positive battery terminal as shown below.

1) OPERATING FLOW

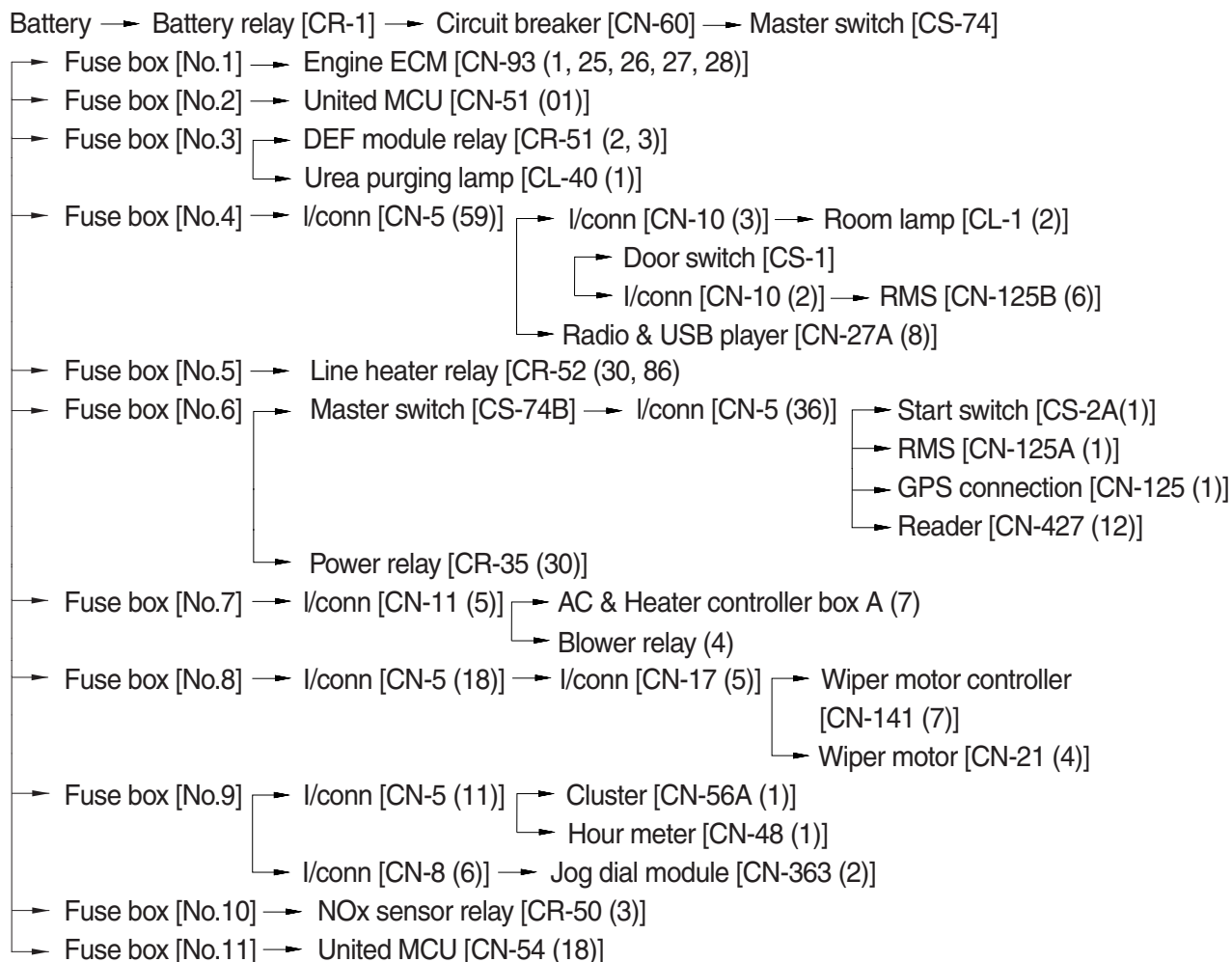

※ I/conn : Intermediate connector

2) CHECK POINT

Engine	Start switch	Check point	Voltage
STOP	OFF	① - GND (battery 1EA)	10~12.5V
		② - GND (battery 2EA)	20~25V
		③ - GND (battery relay)	20~25V
		④ - GND (circuit breaker)	20~25V

※ GND : Ground

POWER CIRCUIT (MACHINE SERIAL NO. : #0042-)

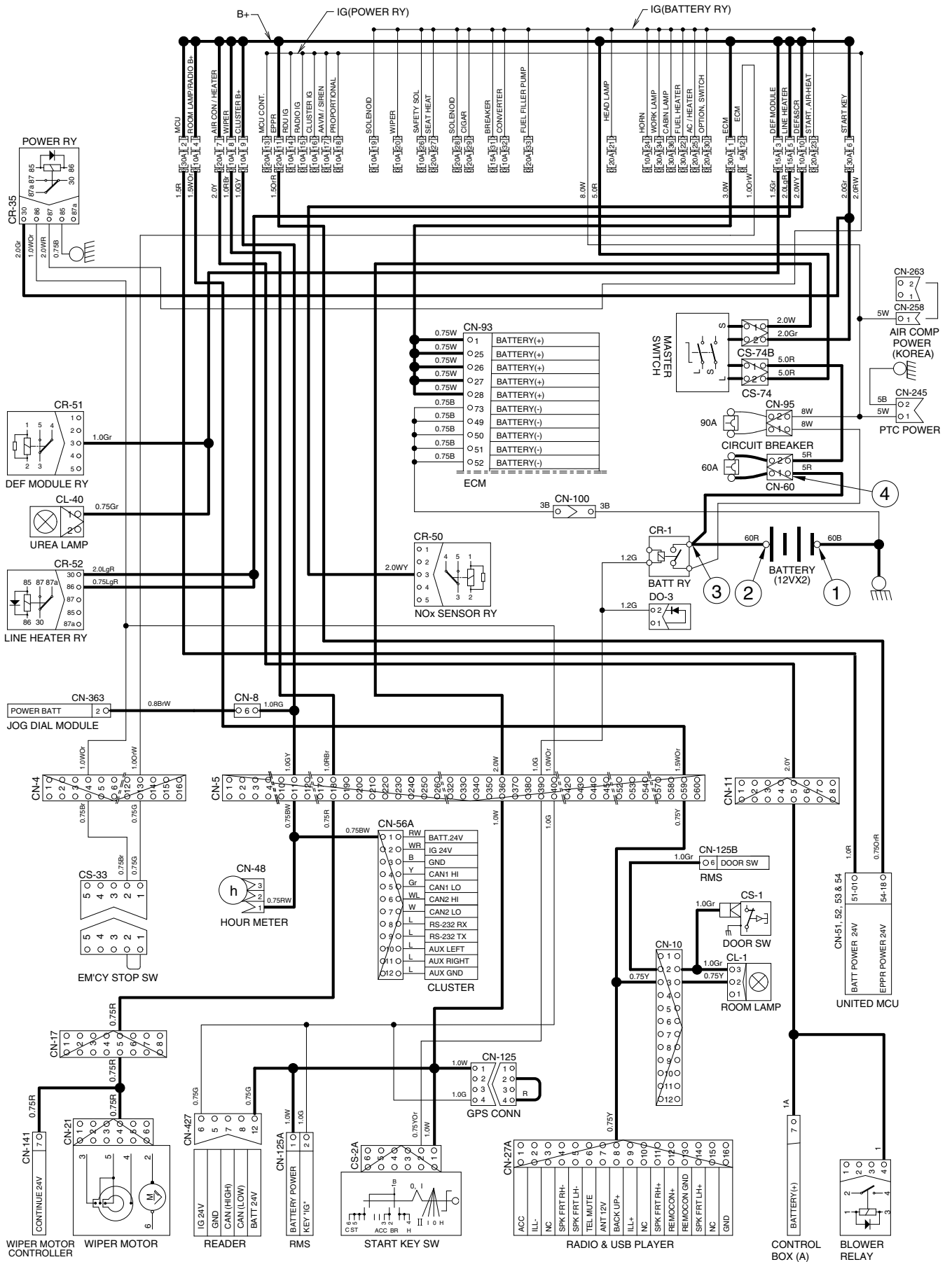

260A4EL05B

2. STARTING CIRCUIT (MACHINE SERIAL NO. : -#0002)

1) OPERATING FLOW

Battery (+) terminal → Battery relay [CR-1] → Circuit breaker [CN-60] → Master switch [CS-74]
 → Fuse box [No.6] → Master switch [CS-74B] → I/conn [CN-5 (36)] → Start switch [CS-2A (1)]
 → Power relay [CR-35 (30)]

(1) When start key switch is in ON position

→ Start switch ON [CS-2A (2)] → I/conn [CN-5 (39)]
 → Battery relay [CR-1] → Battery relay operating (all power is supplied with the electric component)
 → Start switch ON [CS-2A (3)] → GPS conn [CN-125 (2) → (4)]
 → I/conn [CN-5 (40)] → Power relay [CR-35 (86) → (87)]
 → Fuse box [IG (power)]
 → I/conn [CN-4 (4)]
 → Emergency engine stop sw [CS-33 (2) → (1)] → I/conn [CN-4 (13)]
 → Fuse box [No. 12] → Engine ECM [CN-93 (5)]
 → Reader [CN-427 (1)]
 → RMS [CN-125A (2)]

(2) When start key switch is in START position

Start switch START [CS-2A (6)] → I/conn [CN-5 (35)] → Anti-restart relay [CR-5 (2) → (5)]
 → I/conn [CN-2 (7)] → Start relay [CR-23 (2)] → Starter motor operating

2) CHECK POINT

Engine	Start switch	Check point	Voltage
OPERATING	START	① - GND (battery) ② - GND (start switch) ③ - GND (battery relay M4) ④ - GND (starter B+) ⑤ - GND (starter M) ⑥ - GND (start relay) ⑦ - GND (battery relay M8)	20~25V

STARTING CIRCUIT (MACHINE SERIAL NO. : -#0002)

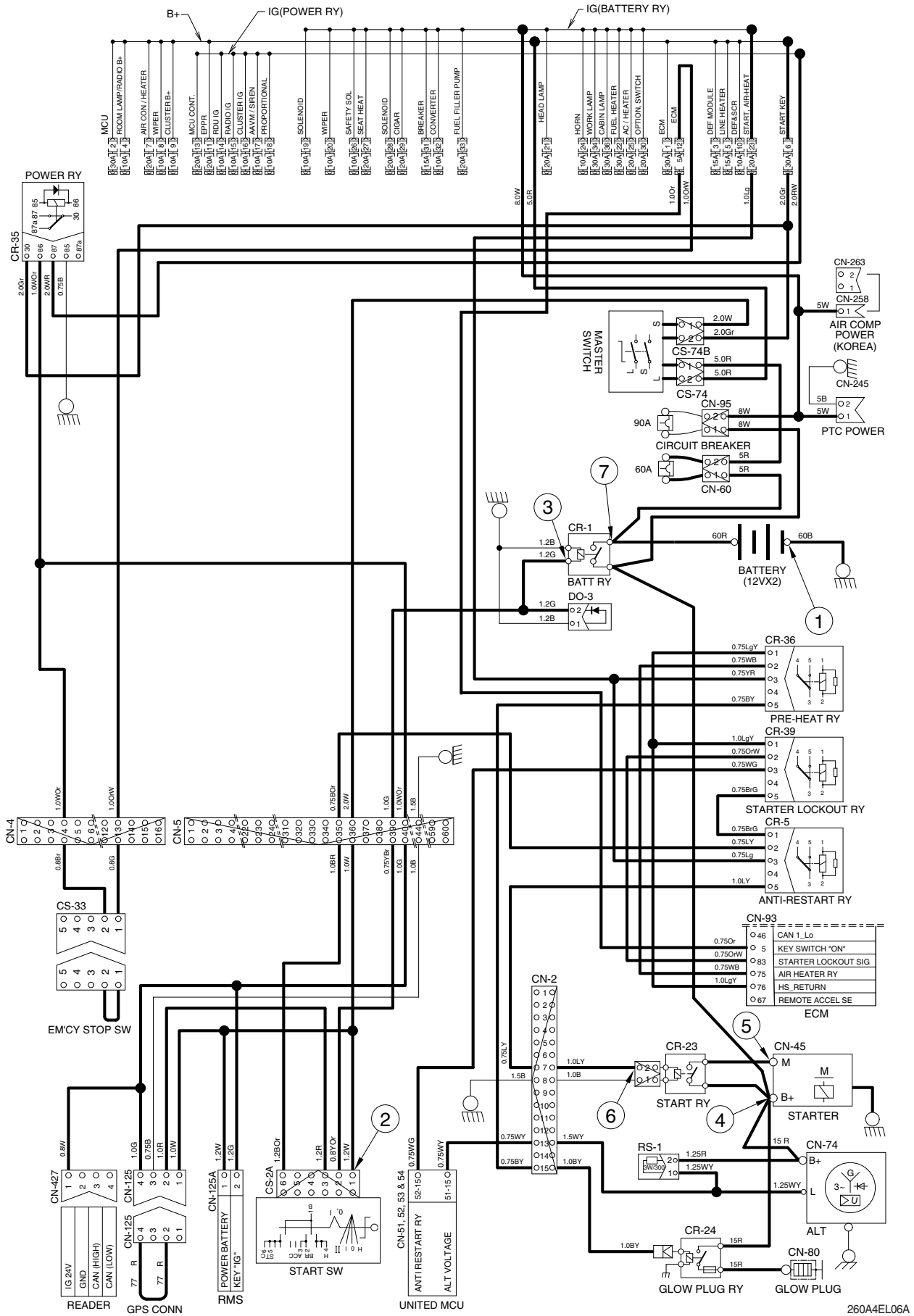

STARTING CIRCUIT (MACHINE SERIAL NO. : #0003-#0041)

1) OPERATING FLOW

Battery (+) terminal → Battery relay [CR-1] → Circuit breaker [CN-60] → Master switch [CS-74]
 → Fuse box [No.6] → Master switch [CS-74B] → I/conn [CN-5 (36)] → Start switch [CS-2A (1)]
 → Power relay [CR-35 (30)]

(1) When start key switch is in ON position

→ Start switch ON [CS-2A (2)] → I/conn [CN-5 (39)]
 → Battery relay [CR-1] → Battery relay operating (all power is supplied with the electric component)
 → Start switch ON [CS-2A (3)] → GPS conn [CN-125 (2) → (4)]
 → I/conn [CN-5 (40)] → Power relay [CR-35 (86) → (87)]
 → Fuse box [IG (power)]
 → I/conn [CN-4 (4)]
 → Emergency engine stop sw [CS-33 (2) → (1)] → I/conn [CN-4 (13)]
 → Fuse box [No. 12] → Engine ECM [CN-93 (5)]
 → Reader [CN-427 (1)]
 → RMS [CN-125A (2)]

(2) When start key switch is in START position

Start switch START [CS-2A (6)] → I/conn [CN-5 (35)] → Anti-restart relay [CR-5 (2) → (5)]
 → I/conn [CN-2 (7)] → Start relay [CR-23 (S)] → Starter motor operating

2) CHECK POINT

Engine	Start switch	Check point	Voltage
OPERATING	START	① - GND (battery) ② - GND (start switch) ③ - GND (battery relay M4) ④ - GND (starter B+) ⑤ - GND (starter M) ⑥ - GND (start relay) ⑦ - GND (battery relay M8)	20~25V

STARTING CIRCUIT (MACHINE SERIAL NO. : #0003-#0041)

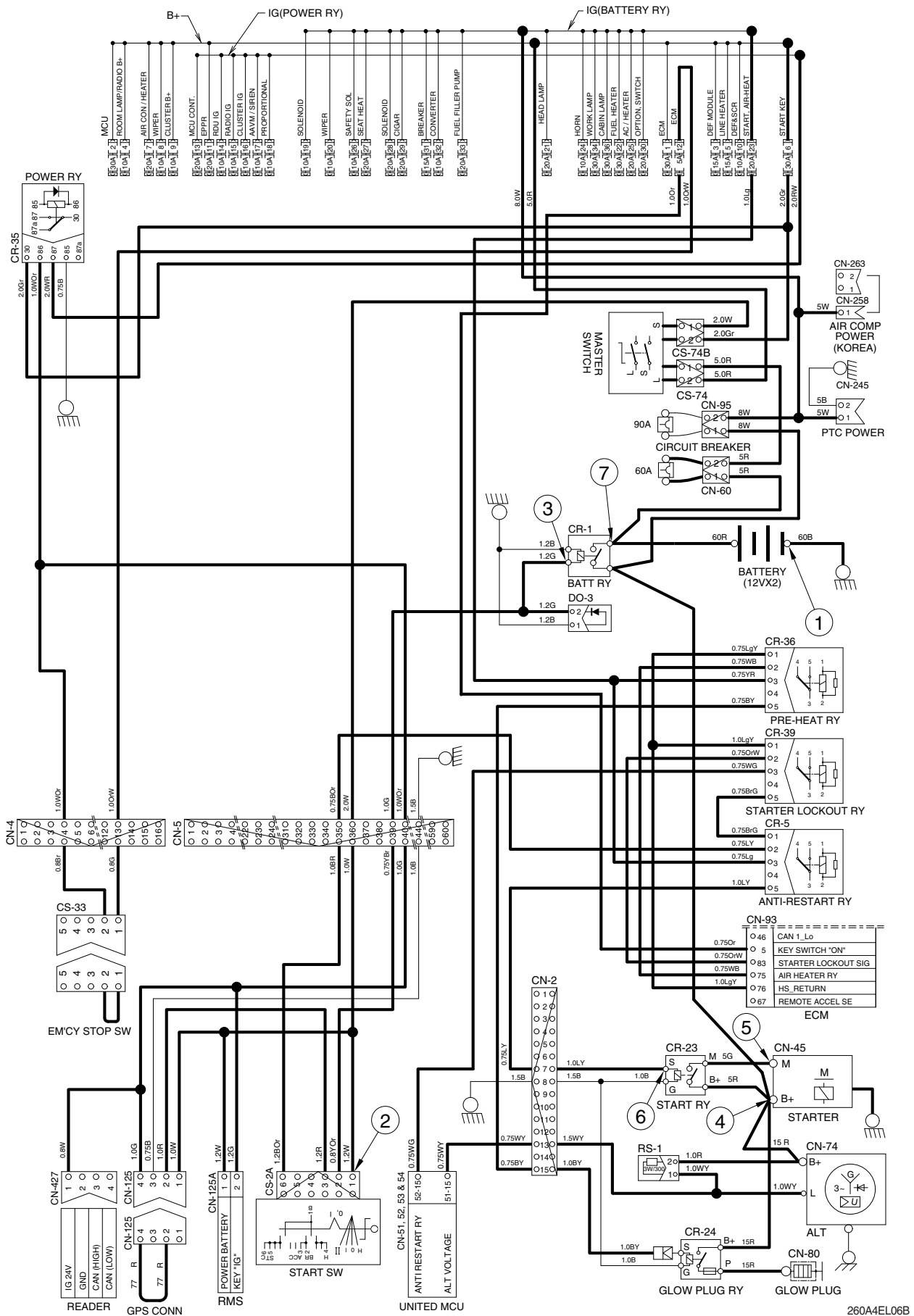

260A4EL06B

STARTING CIRCUIT (MACHINE SERIAL NO. : #0042-)

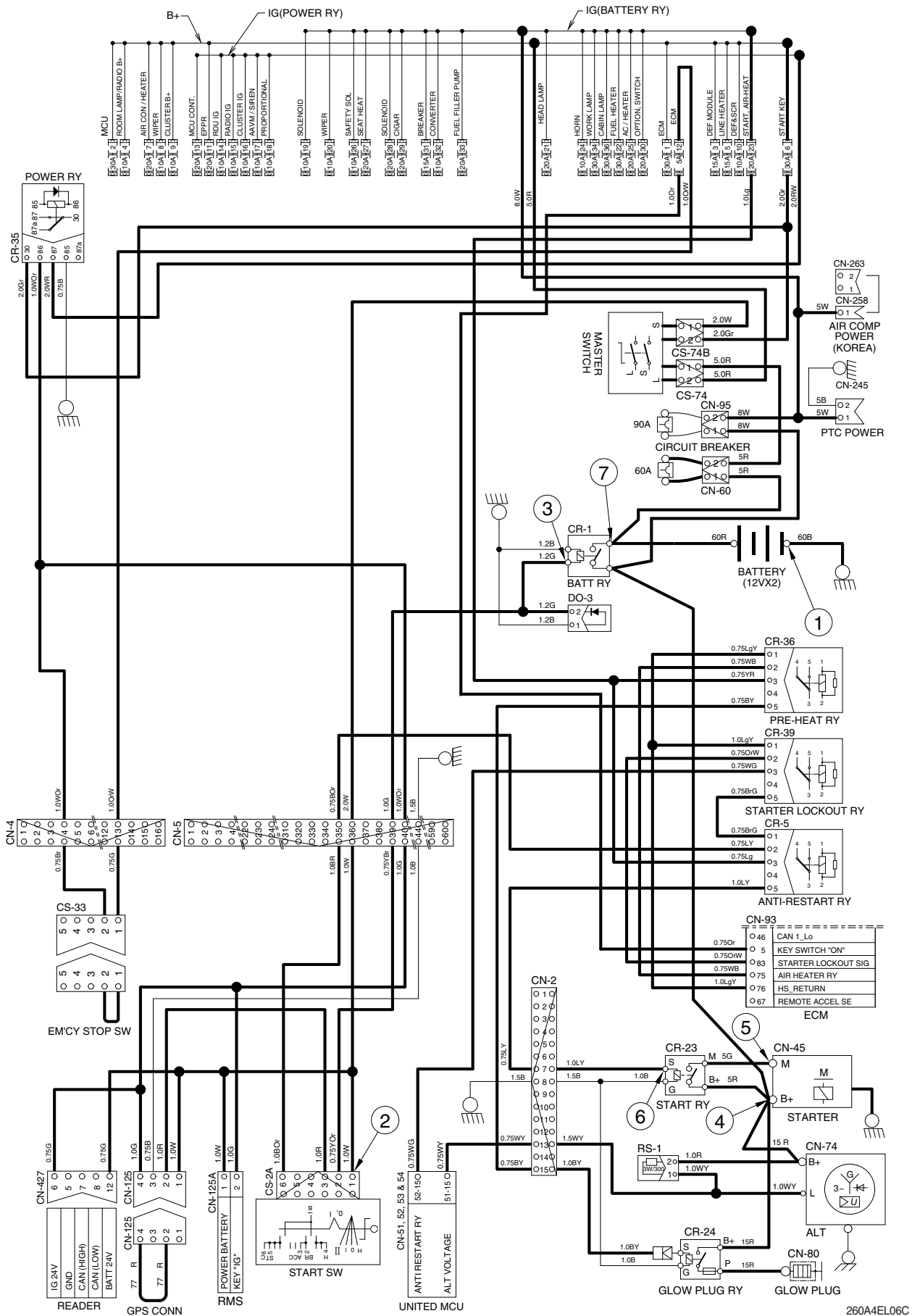

3. CHARGING CIRCUIT (MACHINE SERIAL NO. : -#0002)

When the starter is activated and the engine is started, the operator releases the start switch to the ON position.

Charging current generated by operating alternator flows into the battery through the battery relay [CR-1].

The current also flows from alternator to each electrical component and controller through the fuse box.

1) OPERATING FLOW

(1) Warning flow

Alternator "L" terminal → I/conn [CN-2 (13)] → United MCU alternator voltage [CN-51 (15)]
 → Cluster charging warning lamp (Via CAN interface)

(2) Charging flow

Alternator "B+" terminal → Starter [CN-45 (B+)] → Battery relay (CR-1)
 → Battery (+) terminal
 → Circuit breaker [CN-60] → Master switch [CS-74] → Fuse box [B+]
 → Circuit breaker [CN-95] → Fuse box [IG, battery] → Power relay [CR-35 (30→87)]
 → Fuse box [IG, power]
 → PTC power [CN-245 (1)]
 → Air comp power [CN-258 (1)]

2) CHECK POINT

Engine	Start switch	Check point	Voltage
OPERATING	ON	① - GND (battery voltage) ② - GND (battery relay) ③ - GND (alternator B ⁺ terminal) ④ - GND (alternator L terminal) ⑤ - GND (United MCU)	20~25V

※ GND : Ground

CHARGING CIRCUIT (MACHINE SERIAL NO. : -#0002)

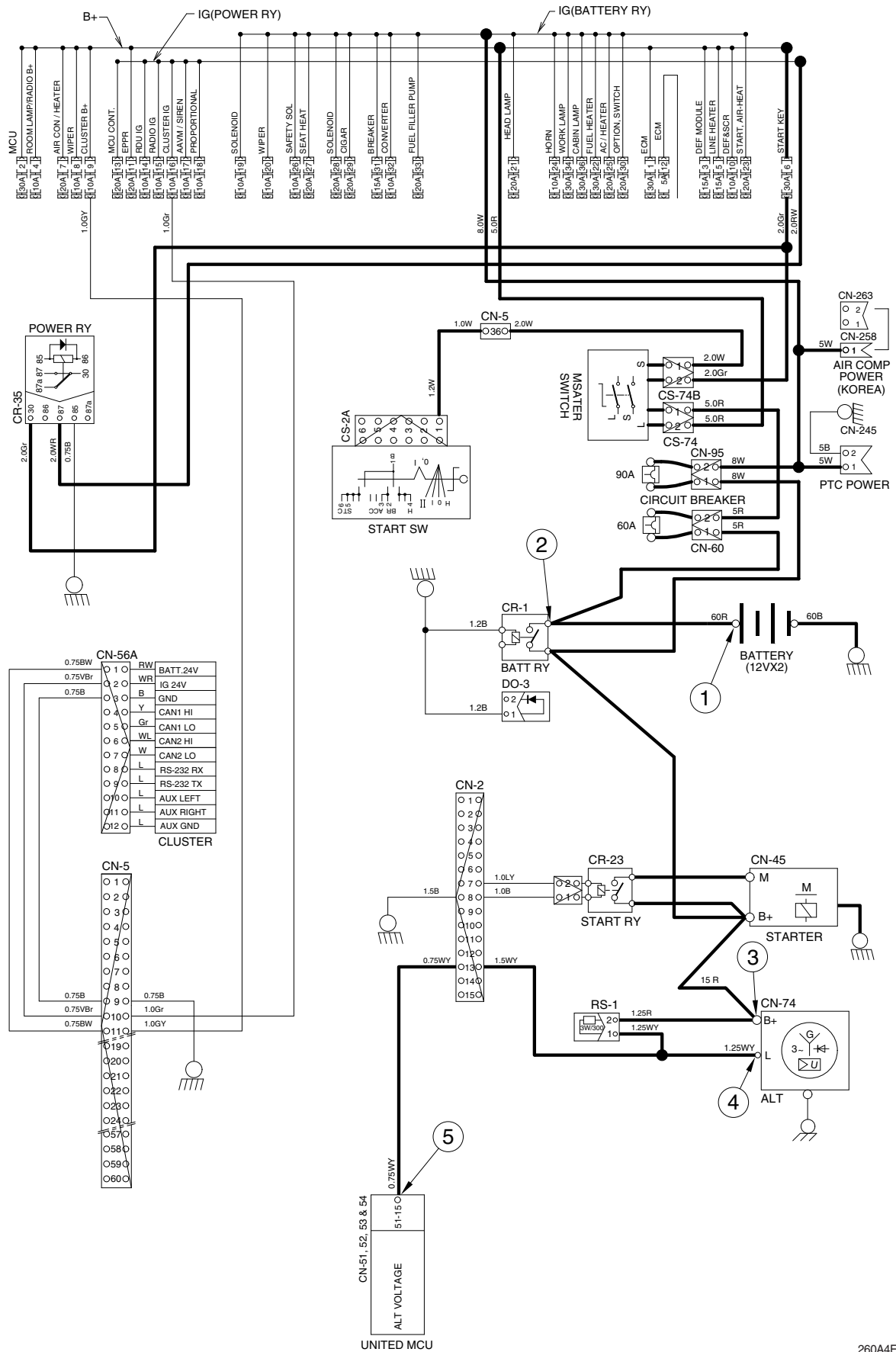

260A4EL07A

CHARGING CIRCUIT (MACHINE SERIAL NO. : #0003-)

When the starter is activated and the engine is started, the operator releases the start switch to the ON position.

Charging current generated by operating alternator flows into the battery through the battery relay [CR-1].

The current also flows from alternator to each electrical component and controller through the fuse box.

1) OPERATING FLOW

(1) Warning flow

Alternator "L" terminal → I/conn [CN-2 (13)] → United MCU alternator voltage [CN-51 (15)]
 → Cluster charging warning lamp (Via CAN interface)

(2) Charging flow

Alternator "B+" terminal → Starter [CN-45 (B⁺)] → Battery relay (CR-1)
 → Battery (+) terminal
 → Circuit breaker [CN-60] → Master switch [CS-74] → Fuse box [B⁺]
 → Circuit breaker [CN-95] → Fuse box [IG, battery] → Power relay [CR-35 (30→87)]
 → Fuse box [IG, power]
 → PTC power [CN-245 (1)]
 → Air comp power [CN-258 (1)]

2) CHECK POINT

Engine	Start switch	Check point	Voltage
OPERATING	ON	① - GND (battery voltage) ② - GND (battery relay) ③ - GND (alternator B ⁺ terminal) ④ - GND (alternator L terminal) ⑤ - GND (United MCU)	20~25V

※ GND : Ground

CHARGING CIRCUIT (MACHINE SERIAL NO. : #0003-)

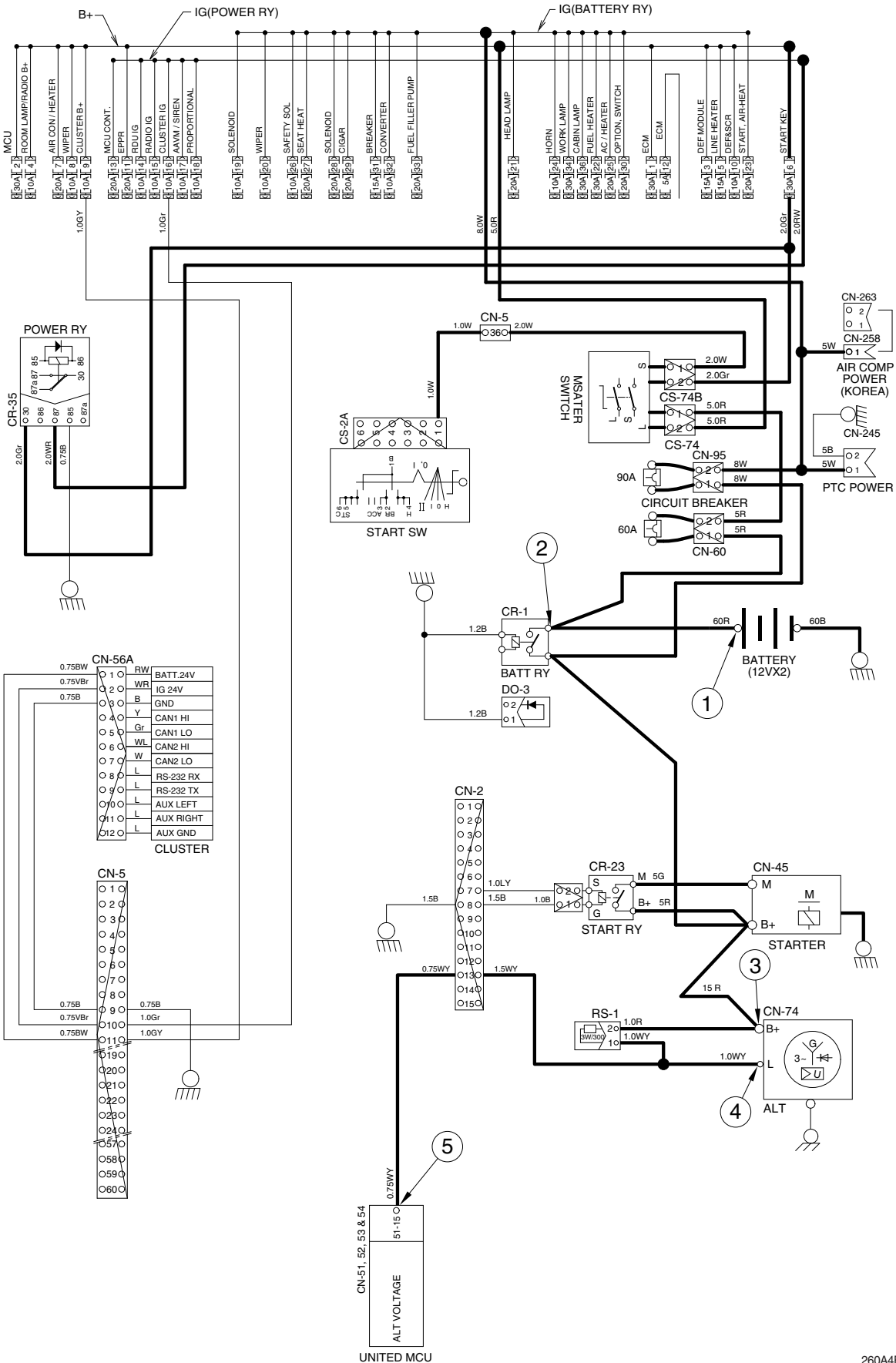

260A4EL07B

4. HEAD AND WORK LIGHT CIRCUIT (MACHINE SERIAL NO. : -#0041)

1) OPERATING FLOW

Fuse box (No.21) → Head light relay [CR-13 (30, 86)]

Fuse box (No.34) → Work light relay [CR-4 (30, 86)]

Fuse box (No.14) → RDU membrane controller [CN-376 (1)]

(1) Head light switch ON

Head light switch ON [CN-376 (13)] → Head light relay [CR-13 (85) → (87)]

→ Head light ON [CL-3 (1), CL-4 (1), CL-24 (1)]

→ I/conn [CN-7 (1)] → Cigar lighter [CL-2]

→ I/conn [CN-5 (60)] → Radio & USB player illumination ON [CN-27A (9)]

(2) Work light switch ON

Work light switch ON [CN-376 (4)] → Work light relay [CR-4 (85) → (87)]

→ I/conn [CN-12 (1)] → Work light ON [CL-5 (1), CL-6 (1)]

2) CHECK POINT

Engine	Start switch	Check point	Voltage
STOP	ON	① - GND (fuse box) ② - GND (switch power output) ③ - GND (head light relay) ④ - GND (head light) ⑤ - GND (fuse box) ⑥ - GND (switch power input) ⑦ - GND (work light relay) ⑧ - GND (work light)	20~25V

※ GND : Ground

HEAD AND WORK LIGHT CIRCUIT (MACHINE SERIAL NO. : -#0041)

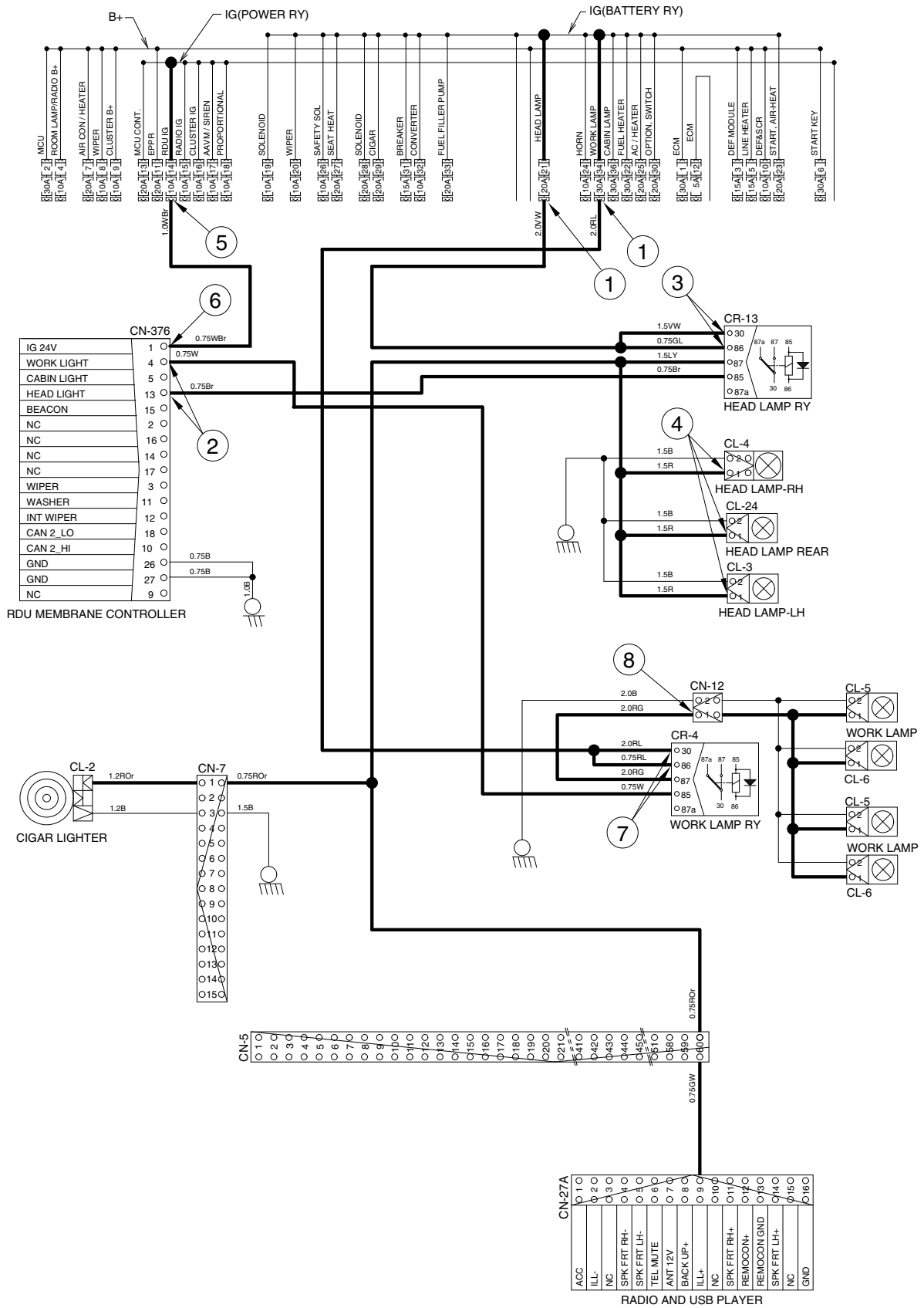

220A4EL08A

HEAD AND WORK LIGHT CIRCUIT (MACHINE SERIAL NO. : #0042-)

1) OPERATING FLOW

Fuse box (No.21) → Head light relay [CR-13 (30, 86)]

Fuse box (No.34) → Work light relay [CR-4 (30, 86)]

Fuse box (No.14) → RDU membrane controller [CN-376 (1)]

(1) Head light switch ON

Head light switch ON [CN-376 (13)] → Head light relay [CR-13 (85) → (87)]

→ Head light ON [CL-3 (1), CL-4 (1), CL-24 (1)]

→ I/conn [CN-7 (1)] → Cigar lighter [CL-2]

→ I/conn [CN-5 (60)] → Radio & USB player illumination ON [CN-27A (9)]

(2) Work light switch ON

Work light switch ON [CN-376 (4)] → Work light relay [CR-4 (85) → (87)]

→ I/conn [CN-12 (1)] → Work light ON [CL-5 (1), CL-6 (1)]

2) CHECK POINT

Engine	Start switch	Check point	Voltage
STOP	ON	① - GND (fuse box) ② - GND (switch power output) ③ - GND (head light relay) ④ - GND (head light) ⑤ - GND (fuse box) ⑥ - GND (switch power input) ⑦ - GND (work light relay) ⑧ - GND (work light)	20~25V

※ GND : Ground

HEAD AND WORK LIGHT CIRCUIT (MACHINE SERIAL NO. : #0042-)

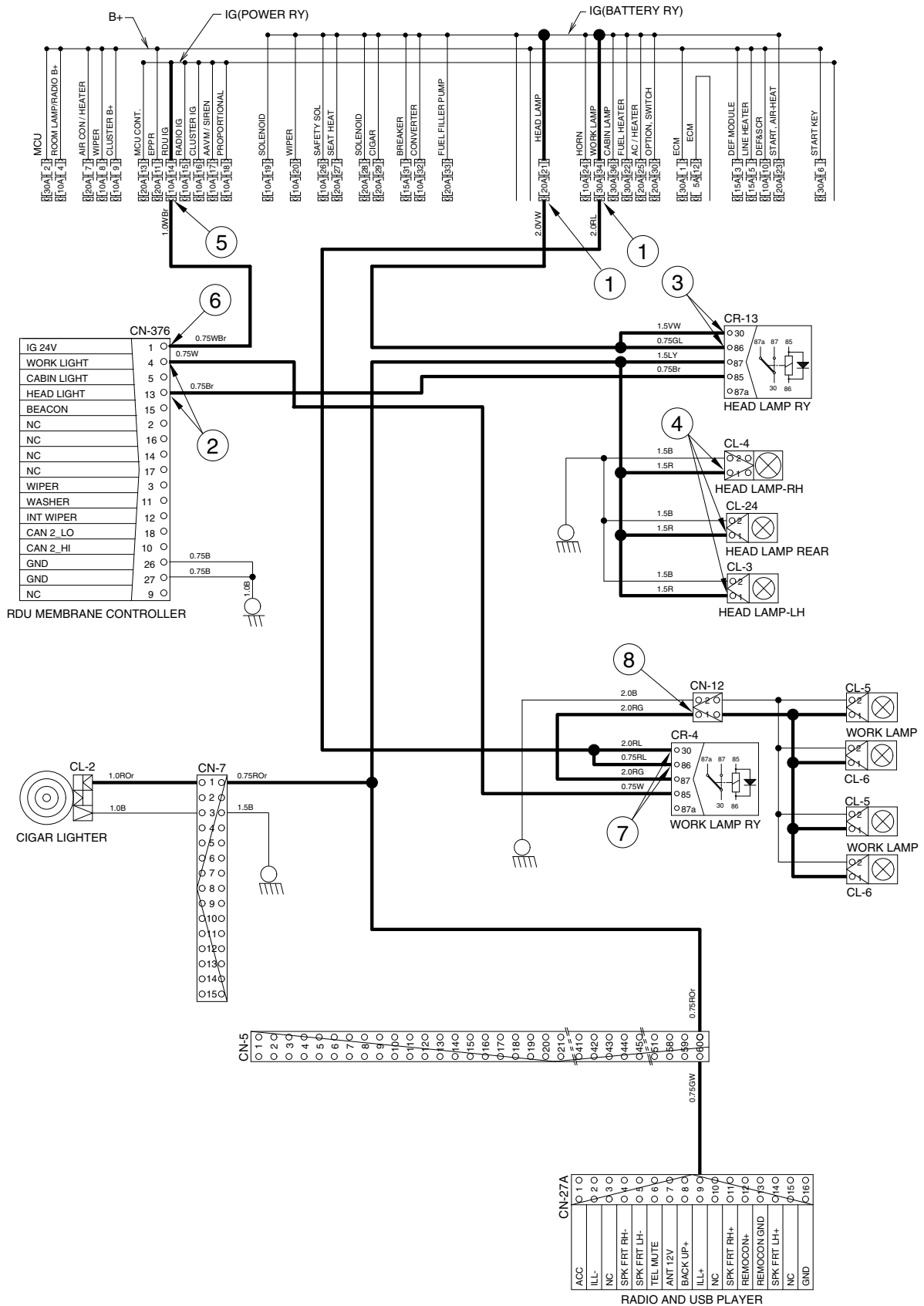

260A4EL08A

5. BEACON LAMP AND CAB LIGHT CIRCUIT (MACHINE SERIAL NO. : -#0041)

1) OPERATING FLOW

Fuse box (No.30) → Beacon lamp relay [CR-85 (2, 3)]

Fuse box (No.36) → Cab light relay [CR-9 (30, 86)]

Fuse box (No.14) → RDU membrane controller [CN-376 (1)]

(1) Beacon lamp switch ON

Beacon lamp switch ON [CN-376 (15)] → Beacon lamp relay [CR-85 (1)→ (5)]

→ I/conn [CN-5 (50)] → I/conn [CN-10 (10)] → Beacon lamp ON [CL-7]

(2) Cab light switch ON

Cab light switch ON [CN-376 (5)] → Cab lamp relay [CR-9 (85)→ (87)]

→ I/conn [CN-5 (34, 38)] → I/conn [CN-10 (11)] → Cab light ON [CL-8 (2)]

→ I/conn [CN-10 (12)] → Cab light ON [CL-9 (2), CL-10 (2)]

2) CHECK POINT

Engine	Start switch	Check point	Voltage
STOP	ON	① - GND (fuse box) ② - GND (beacon lamp relay) ③ - GND (switch power output) ④ - GND (beacon lamp) ⑤ - GND (fuse box) ⑥ - GND (cabin light relay) ⑦ - GND (switch power input) ⑧ - GND (cab light)	20~25V

※ GND : Ground

BEACON LAMP AND CAB LIGHT CIRCUIT (MACHINE SERIAL NO. : -#0041)

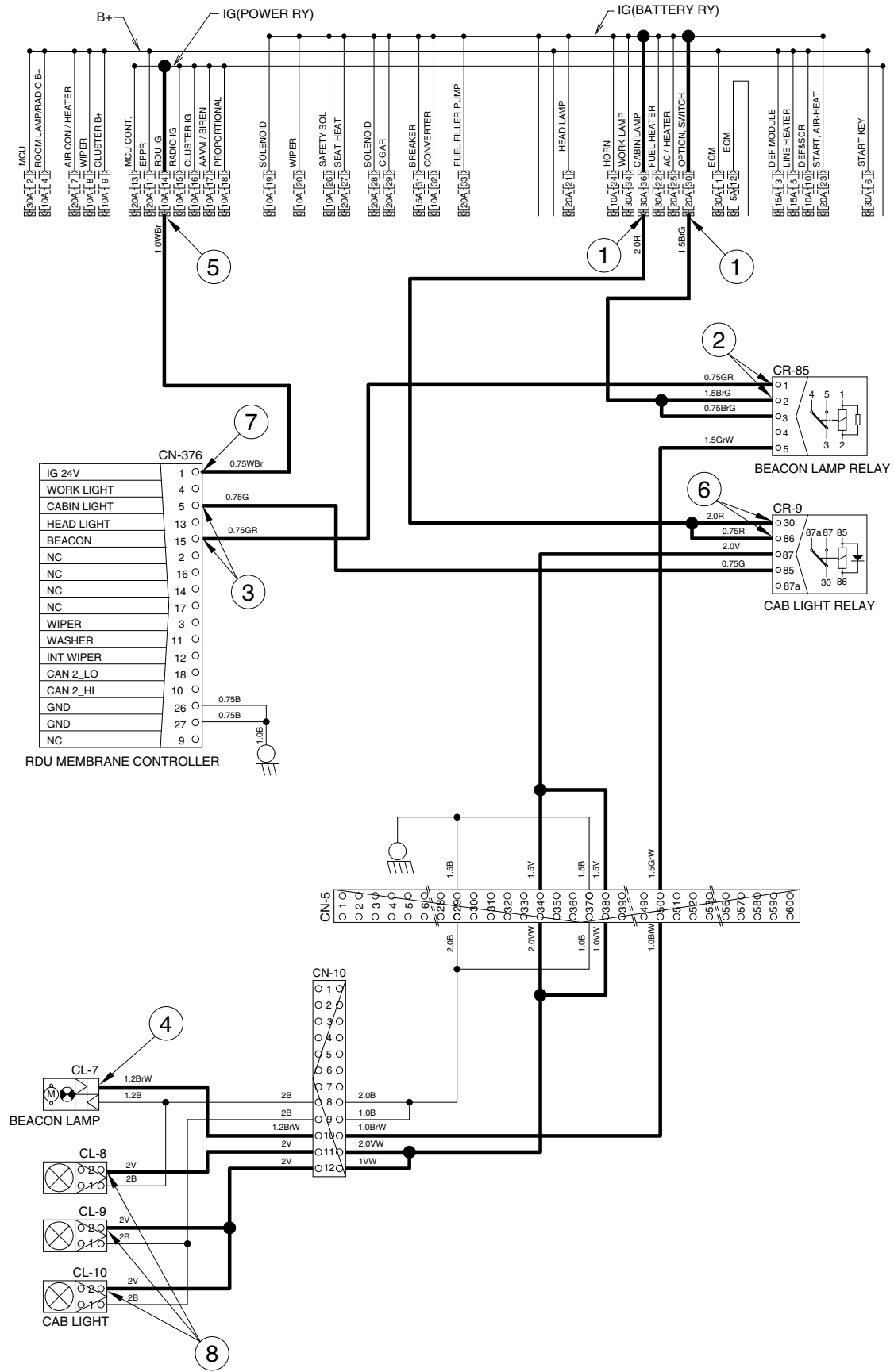

220A4EL09A

BEACON LAMP AND CAB LIGHT CIRCUIT (MACHINE SERIAL NO. : #0042-)

1) OPERATING FLOW

Fuse box (No.30) → Beacon lamp relay [CR-85 (2, 3)]

Fuse box (No.36) → Cab light relay [CR-9 (30, 86)]

Fuse box (No.14) → RDU membrane controller [CN-376 (1)]

(1) Beacon lamp switch ON

Beacon lamp switch ON [CN-376 (15)] → Beacon lamp relay [CR-85 (1)→ (5)]

→ I/conn [CN-5 (50)] → I/conn [CN-10 (10)] → Beacon lamp ON [CL-7 (2)]

(2) Cab light switch ON

Cab light switch ON [CN-376 (5)] → Cab lamp relay [CR-9 (85)→ (87)]

→ I/conn [CN-5 (34, 38)] → I/conn [CN-10 (11)] → Cab light ON [CL-8 (2)]

→ I/conn [CN-10 (12)] → Cab light ON [CL-9 (2), CL-10 (2)]

2) CHECK POINT

Engine	Start switch	Check point	Voltage
STOP	ON	① - GND (fuse box) ② - GND (beacon lamp relay) ③ - GND (switch power output) ④ - GND (beacon lamp) ⑤ - GND (fuse box) ⑥ - GND (cabin light relay) ⑦ - GND (switch power input) ⑧ - GND (cab light)	20~25V

※ GND : Ground

BEACON LAMP AND CAB LIGHT CIRCUIT (MACHINE SERIAL NO. : #0042-)

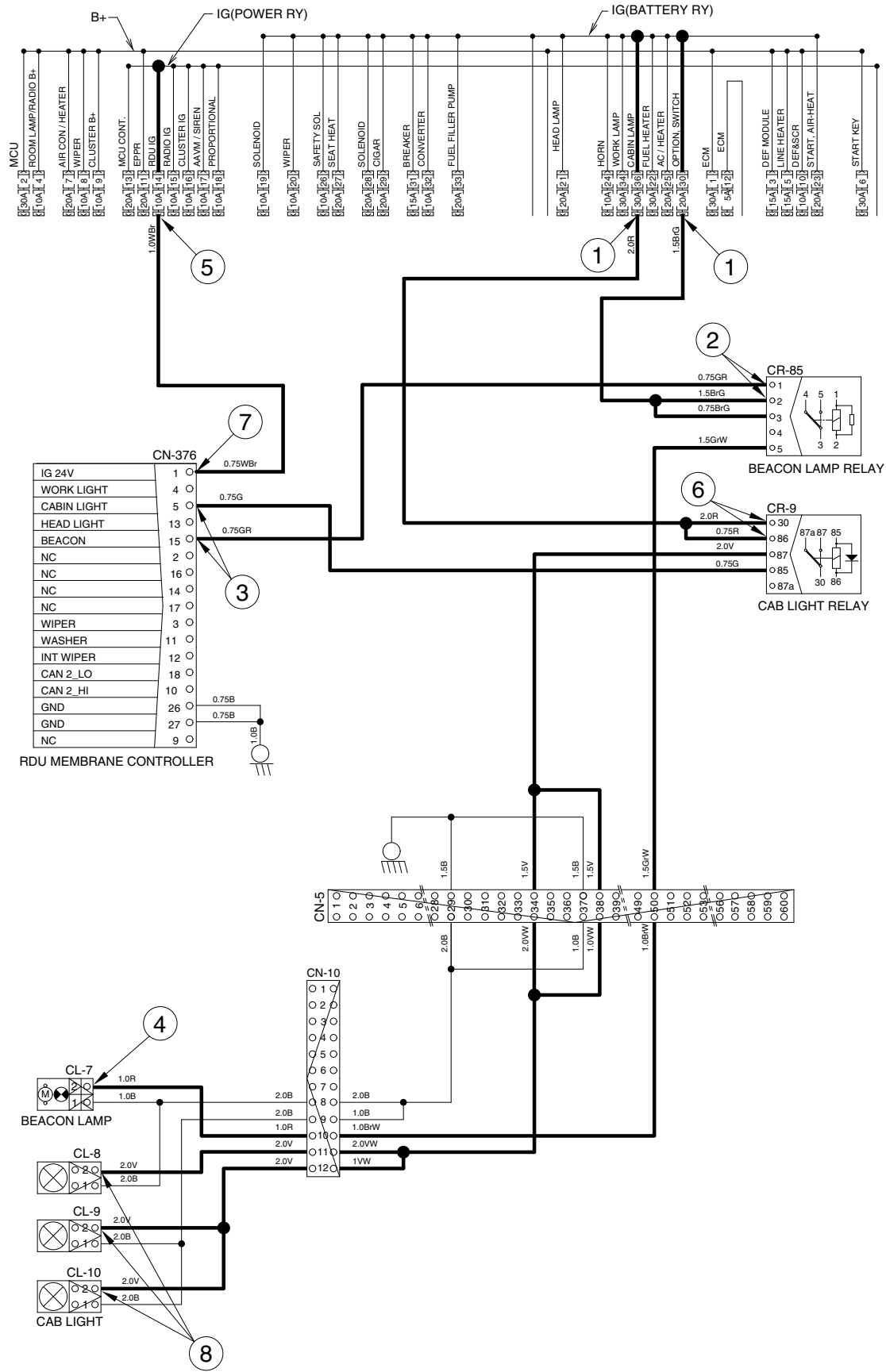

260A4EL09A

6. WIPER AND WASHER CIRCUIT (MACHINE SERIAL NO. : -#0041)

1) OPERATING FLOW

(1) Key switch ON

Fuse box (No.14) → RDU membrane controller [CN-376 (1)]

Fuse box (No.8) → I/conn [CN-5 (18)] → I/conn [CN-17 (5)] → Wiper motor controller [CN-141 (7)]
 → Wiper motor [CN-21 (4)]

Fuse box (No.20) → I/conn [CN-5 (16)] → I/conn [CN-17 (4)] → Wiper motor controller [CN-141 (6)]
 → Low wiper motor [CN-407 (3)]
 → Washer pump [CN-22 (2)]

(2) Wiper switch ON (Intermittent)

Wiper switch ON [CN-376 (12)] → I/conn [CN-5 (20)] → I/conn [CN-17 (8)]

→ Wiper motor controller [CN-141 (10)→(3)] → Wiper motor [CN-21 (6)] → Intermittently operating

(3) Wiper switch ON (continual)

Wiper switch ON [CN-376 (3)] → I/conn [CN-5 (15)] → I/conn [CN-17 (2)]

→ Wiper motor controller [CN-141 (2) → (4)] → Wiper motor [CN-21 (2)] → Continual operating

(4) Washer switch ON

Washer switch ON [CN-376 (11)] → I/conn [CN-5 (17)] → I/conn [CN-17 (7)]

→ Wiper motor controller [CN-141 (9) → (8)] → I/conn [CN-17 (6)] → I/conn [CN-5 (19)]

→ Washer pump [CN-22 (1)] → Washer operating

Wiper switch ON [CN-376 (3)] → I/conn [CN-5 (15)] → I/conn [CN-17 (2)]

→ Wiper motor controller [CN-141 (2) → (4)] → Wiper motor [CN-21 (2)] → Continual operating

(5) Auto parking (when switch OFF)

Switch OFF [CN-376 (3, 12)] → Wiper motor parking position by wiper motor controller

2) OPERATING FLOW (LOW WIPER)

(1) Key switch ON

Fuse box (No. 30) → I/conn [CN-7 (8)] → Low wiper switch [CS-79 (1, 5)]

(2) Wiper switch ON (1st)

Wiper switch ON [CS-79 (1 → 2)] → I/conn [CN-7 (5)] → Wiper motor [CN-407 (4)] → Wiper operating

(3) Wiper switch ON (2nd)

Wiper switch ON [CS-79 (5 → 4)] → I/conn [CN-7 (6)] → I/conn [CN-18 (2)] → Washer pump [CN-407 (2)]

→ Washer operating

Wiper switch ON [CS-79 (1 → 2)] → I/conn [CN-7 (5)] → Wiper motor [CN-407 (4)] → Wiper operating

3) CHECK POINT

Engine	Start switch	Check point	Voltage
STOP	ON	① - GND (fuse box)	20~25V
		② - GND (switch power input)	
		③ - GND (wiper power input)	
		④ - GND (switch power output)	
		⑤ - GND (switch power output)	0 ~ 5V
		⑥ - GND (wiper power switch input)	
		⑦ - GND (wiper power output)	
		⑧ - GND (wiper motor)	
			0 or 24V

※ GND : Ground

WIPER AND WASHER CIRCUIT (MACHINE SERIAL NO. : -#0041)

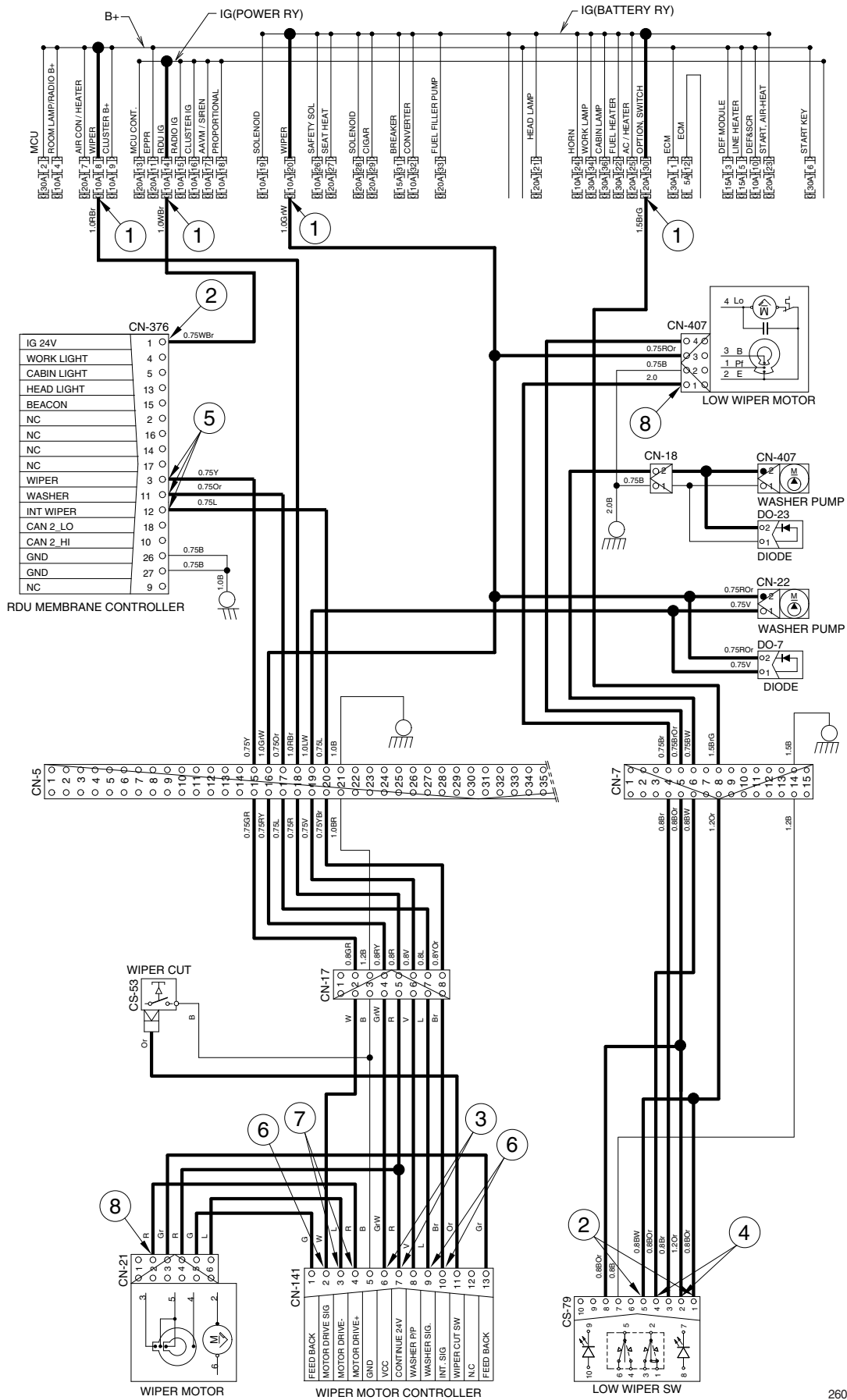

260A4EL10

WIPER AND WASHER CIRCUIT (MACHINE SERIAL NO. : #0042-)

1) OPERATING FLOW

(1) Key switch ON

Fuse box (No.14) → RDU membrane controller [CN-376 (1)]

Fuse box (No.8) → I/conn [CN-5 (18)] → I/conn [CN-17 (5)] → Wiper motor controller [CN-141 (7)]
 → Wiper motor [CN-21 (4)]

Fuse box (No.20) → I/conn [CN-5 (16)] → I/conn [CN-17 (4)] → Wiper motor controller [CN-141 (6)]
 → Low wiper motor [CN-407 (3)]
 → Washer pump [CN-22 (2)]

(2) Wiper switch ON (Intermittent)

Wiper switch ON [CN-376 (12)] → I/conn [CN-5 (20)] → I/conn [CN-17 (8)]

→ Wiper motor controller [CN-141 (10)→(3)] → Wiper motor [CN-21 (6)] → Intermittently operating

(3) Wiper switch ON (continual)

Wiper switch ON [CN-376 (3)] → I/conn [CN-5 (15)] → I/conn [CN-17 (2)]

→ Wiper motor controller [CN-141 (2) → (4)] → Wiper motor [CN-21 (2)] → Continual operating

(4) Washer switch ON

Washer switch ON [CN-376 (11)] → I/conn [CN-5 (17)] → I/conn [CN-17 (7)]

→ Wiper motor controller [CN-141 (9) → (8)] → I/conn [CN-17 (6)] → I/conn [CN-5 (19)]

→ Washer pump [CN-22 (1)] → Washer operating

Wiper switch ON [CN-376 (3)] → I/conn [CN-5 (15)] → I/conn [CN-17 (2)]

→ Wiper motor controller [CN-141 (2) → (4)] → Wiper motor [CN-21 (2)] → Continual operating

(5) Auto parking (when switch OFF)

Switch OFF [CN-376 (3, 12)] → Wiper motor parking position by wiper motor controller

2) OPERATING FLOW (LOW WIPER)

(1) Key switch ON

Fuse box (No. 30) → I/conn [CN-7 (8)] → Low wiper switch [CS-79 (1, 5)]

(2) Wiper switch ON (1st)

Wiper switch ON [CS-79 (1 → 2)] → I/conn [CN-7 (5)] → Wiper motor [CN-407 (4)] → Wiper operating

(3) Wiper switch ON (2nd)

Wiper switch ON [CS-79 (5 → 4)] → I/conn [CN-7 (6)] → I/conn [CN-18 (2)] → Washer pump [CN-407 (2)]

→ Washer operating

Wiper switch ON [CS-79 (1 → 2)] → I/conn [CN-7 (5)] → Wiper motor [CN-407 (4)] → Wiper operating

3) CHECK POINT

Engine	Start switch	Check point	Voltage
STOP	ON	① - GND (fuse box)	20~25V
		② - GND (switch power input)	
		③ - GND (wiper power input)	
		④ - GND (switch power output)	
		⑤ - GND (switch power output)	0 ~ 5V
		⑥ - GND (wiper power switch input)	
		⑦ - GND (wiper power output)	
		⑧ - GND (wiper motor)	
			0 or 24V

※ GND : Ground

WIPER AND WASHER CIRCUIT (MACHINE SERIAL NO. : #0042-)

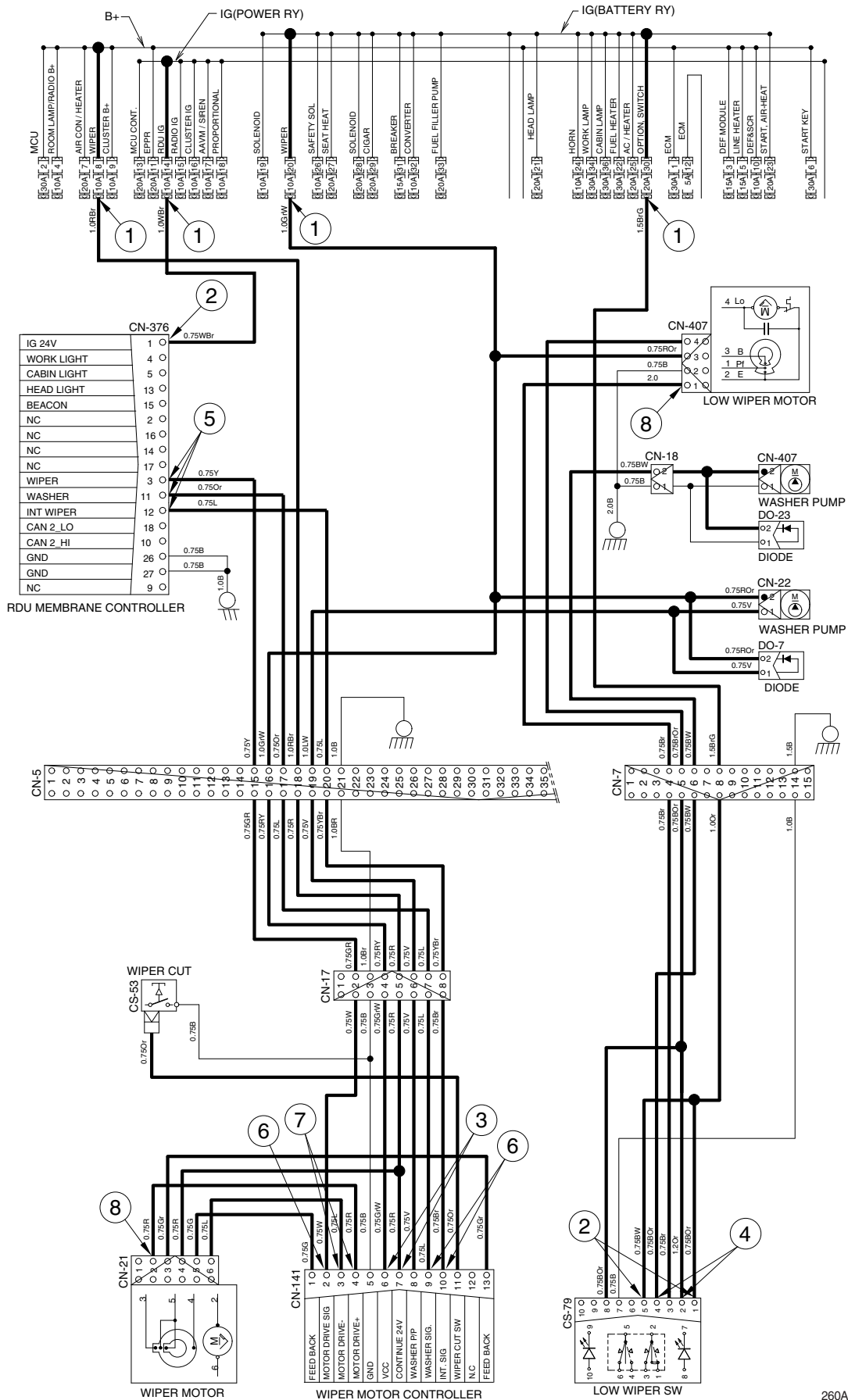

260A4EL10A

7. CONTROLLER CIRCUIT (MACHINE SERIAL NO. : #0001-)

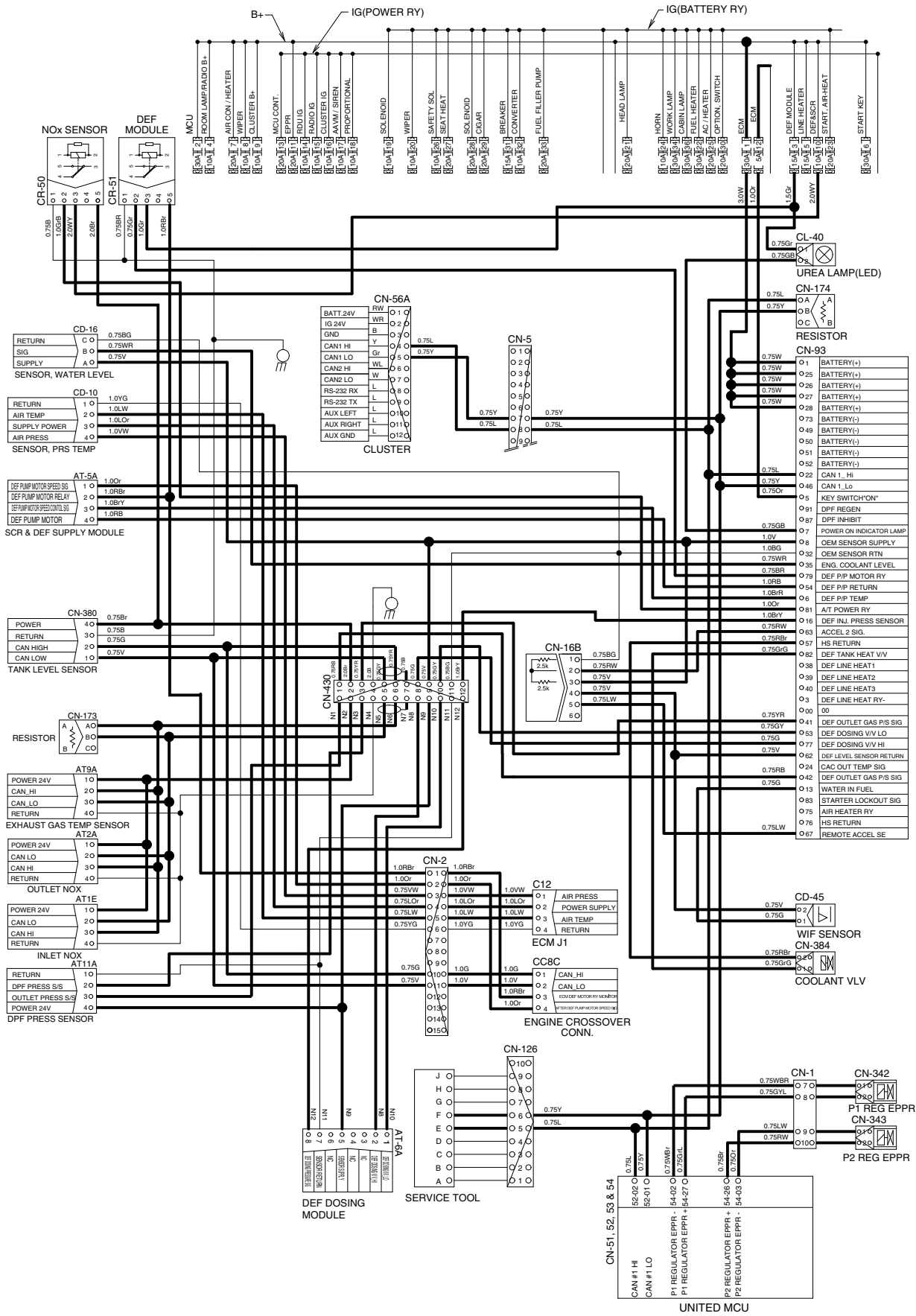

8. MONITORING CIRCUIT (MACHINE SERIAL NO. : -#0041)

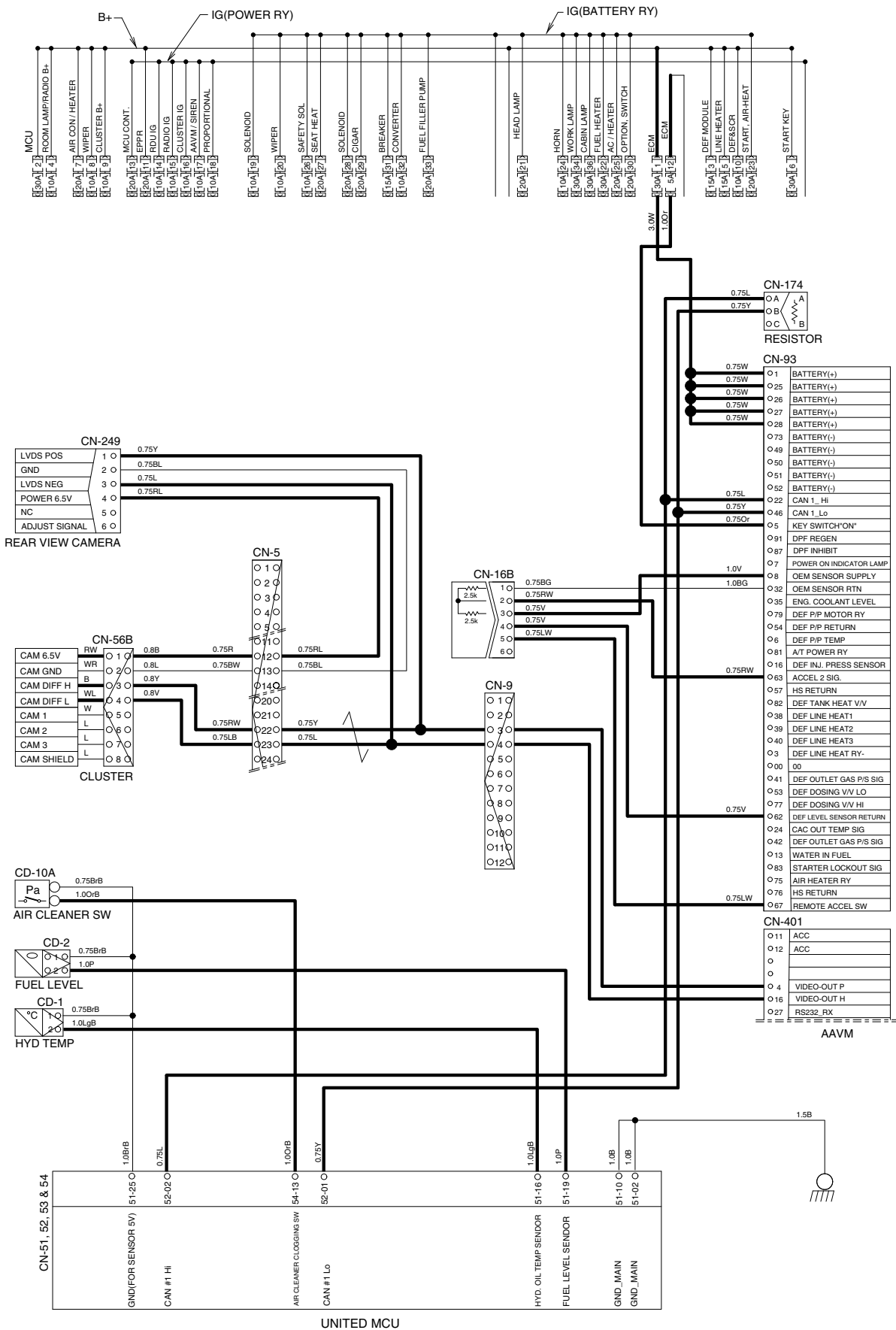

MONITORING CIRCUIT (MACHINE SERIAL NO. : #0042-)

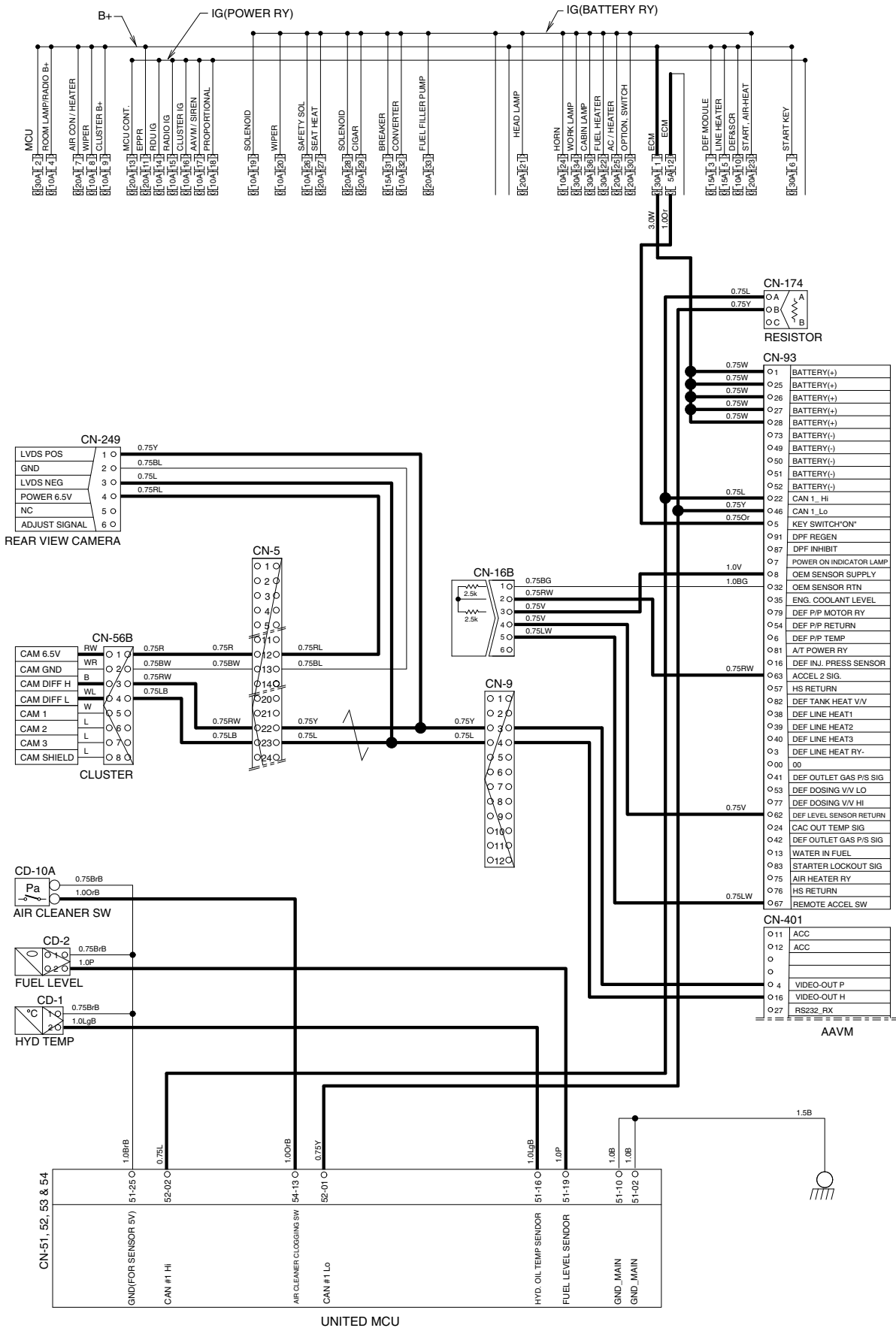

9. ELECTRIC CIRCUIT FOR HYDRAULIC (1/2, MACHINE SERIAL NO. : #0001-)

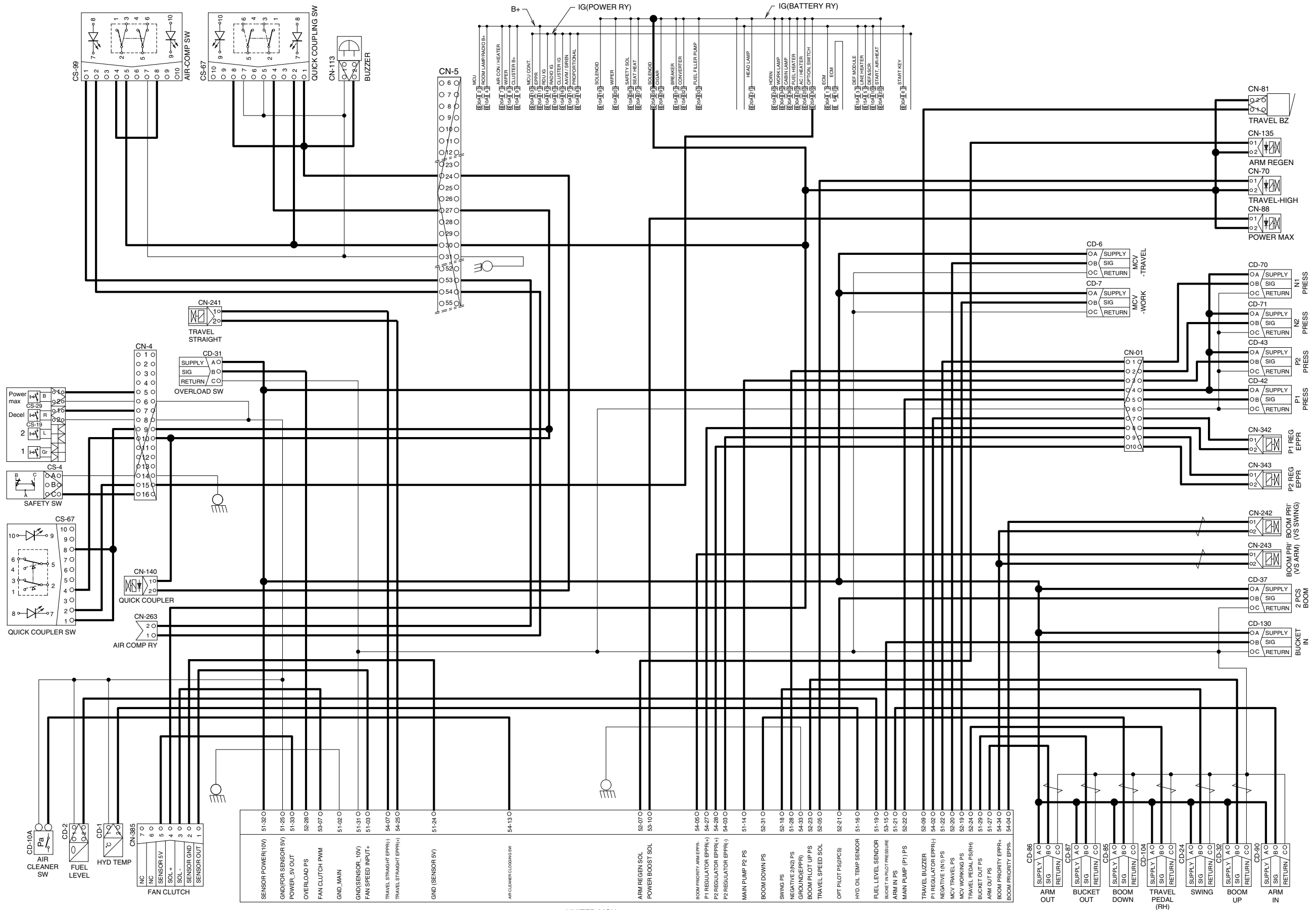

UNITED MCU

10. ELECTRIC CIRCUIT FOR HYDRAULIC (2/2, MACHINE SERIAL NO. : -#0002)

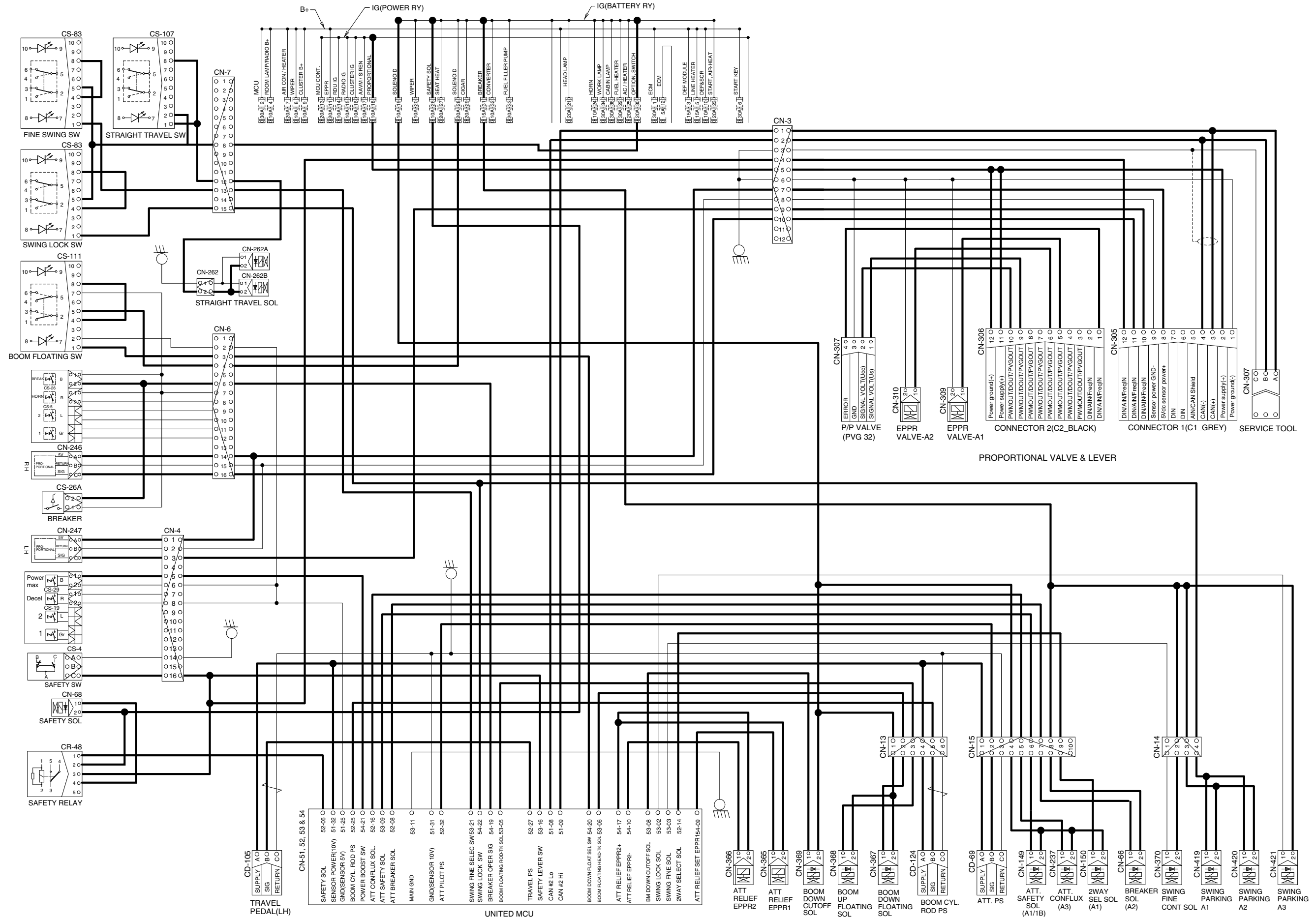

ELECTRIC CIRCUIT FOR HYDRAULIC (2/2, MACHINE SERIAL NO. : #0003-#0041)

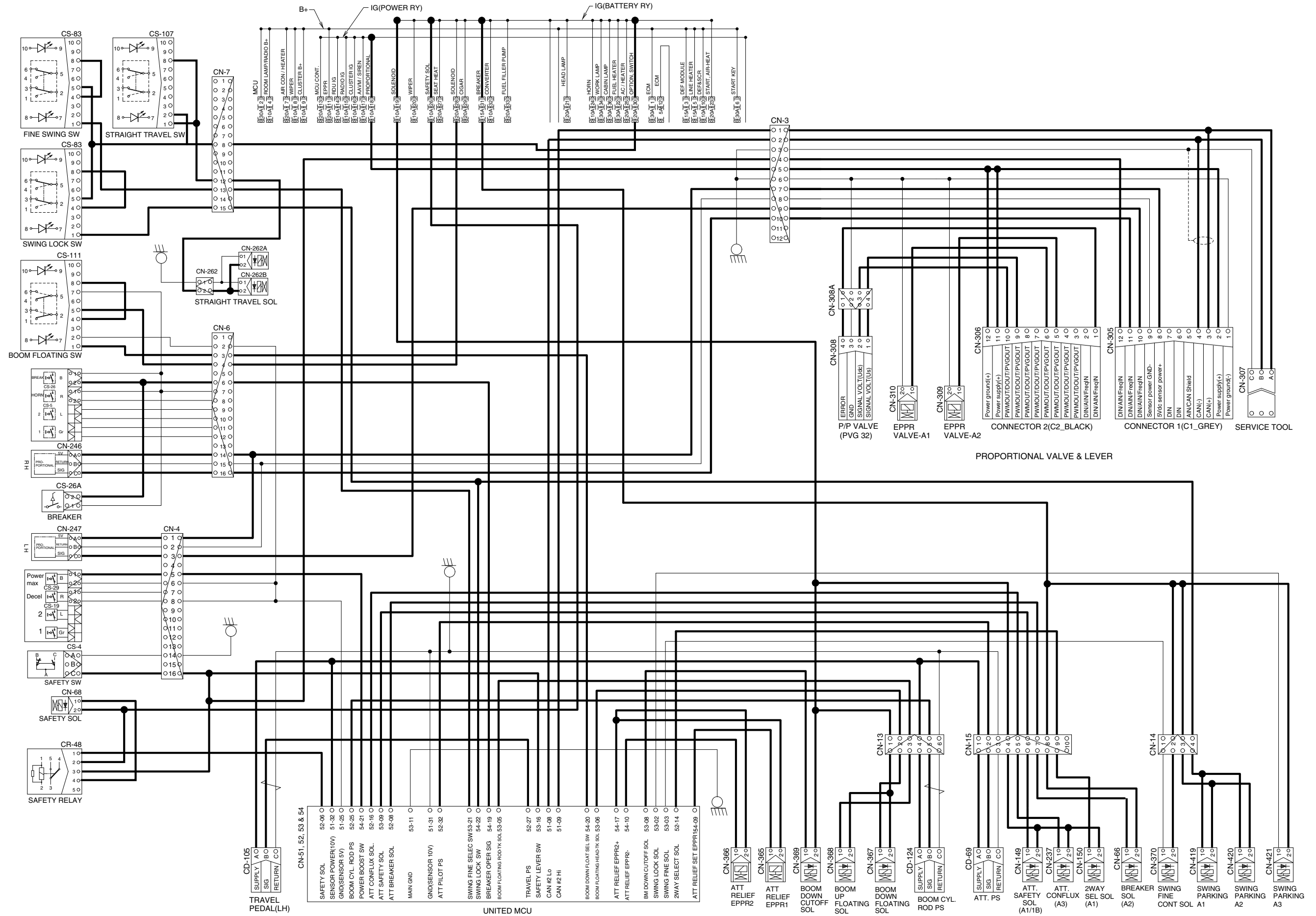

ELECTRIC CIRCUIT FOR HYDRAULIC (2/2, MACHINE SERIAL NO. : #0042-)

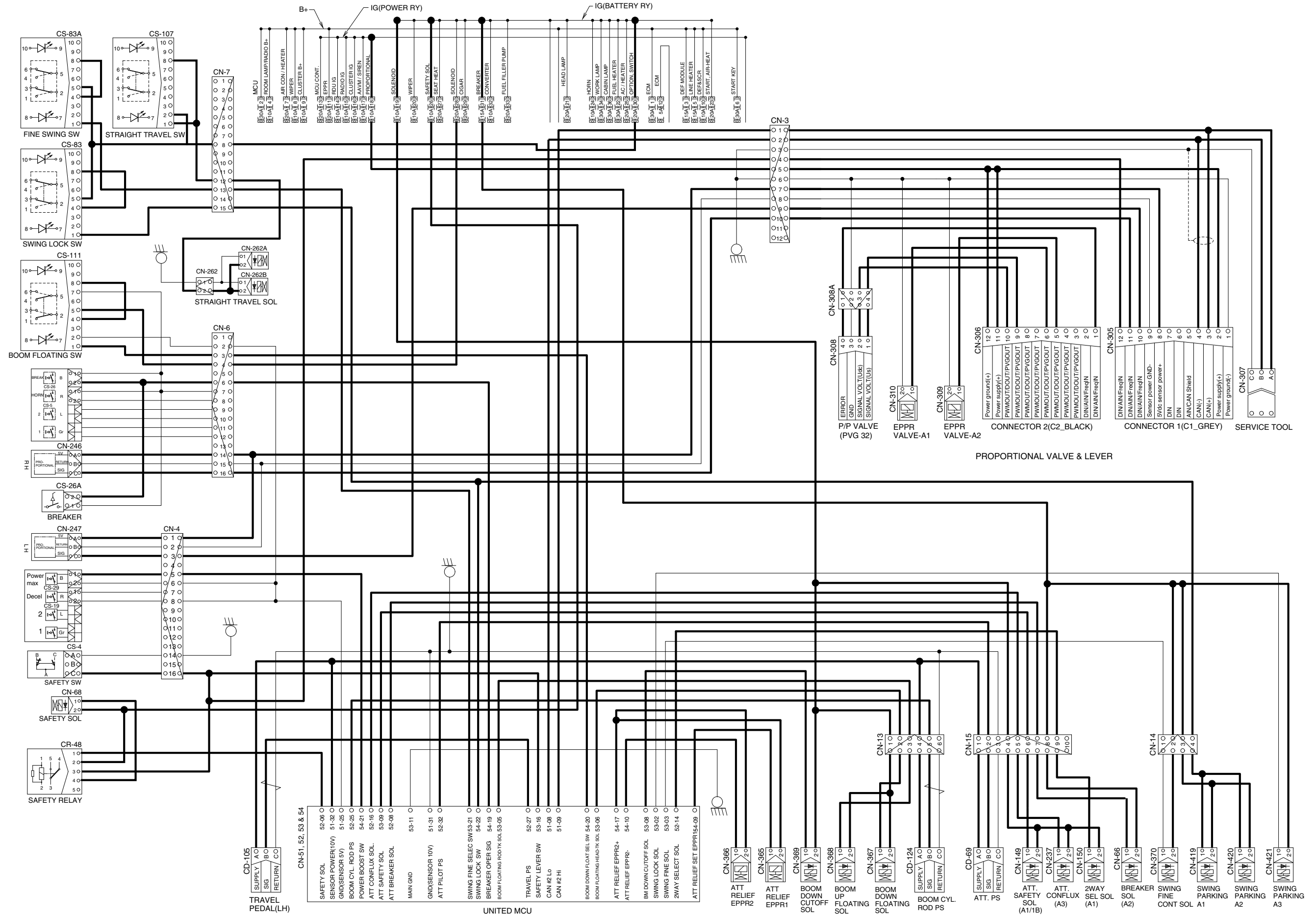

GROUP 3 ELECTRICAL COMPONENT SPECIFICATION

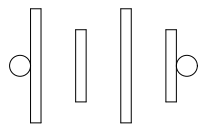
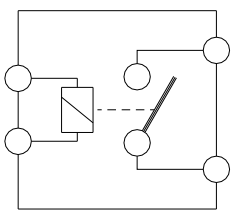
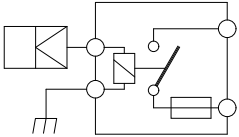
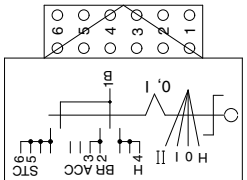
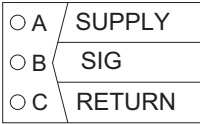
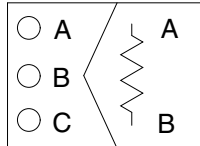
Part name	Symbol	Specifications	Check
Battery		12V × 160Ah (2EA)	※ Check specific gravity 1.280 over : Over charged 1.280 ~ 1.250 : Normal 1.250 below : Recharging
Battery relay	 <p style="text-align: center;">CR-1</p>	Rated load : 24V 100A (continuity) 1000A (30seconds)	※ Check coil resistance(M4 to M4) Normal : About 50Ω ※ Check contact Normal : ∞ Ω
Glow plug relay	 <p style="text-align: center;">CR-24</p>	24V 200A	※ Check contact Normal : 0.942Ω (for terminal 1-GND)
Start key	 <p style="text-align: center;">CS-2A</p>	B-BR : 24V 1A B-ACC : 24V 10A B-ST : 24V 40A	※ Check contact OFF : ∞ Ω (for each terminal) ON : 0Ω (for terminal 1-3 and 1-2) START : 0Ω (for terminal 1-6)
Pressure sensor	 <p> ○ A SUPPLY ○ B SIG ○ C RETURN </p> <p> CD-16 CD-24 CD-31 CD-32 CD-37 CD-42 CD-43 CD-69 CD-70 CD-71 CD-85 CD-86 CD-87 CD-90 CD-104 CD-105 CD-124 CD-130 </p>	8~30V	※ Check contact Normal : 0.1Ω
Resistor	 <p style="text-align: center;">CN-173 CN-174</p>	3W	※ Check resistance A-B : 120Ω

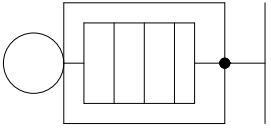
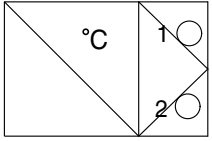
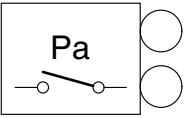
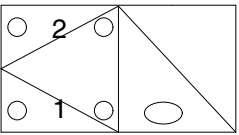
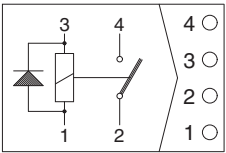
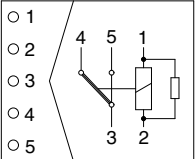
Part name	Symbol	Specifications	Check
Glow plug	 CN-80	24V 200A	※ Check resistance 0.25~0.12Ω
Temperature sensor (hydraulic)	 CD-1	-	※ Check resistance 50°C : 804Ω 80°C : 310Ω 100°C : 180Ω
Air cleaner pressure switch	 CD-10A	N.O TYPE	※ Check contact High level : ∞Ω Low level : 0Ω
Fuel level sender	 CD-2	-	※ Check resistance Full : 50Ω 6/12 : 350Ω 11/12 : 100Ω 5/12 : 400Ω 10/12 : 150Ω 4/12 : 450Ω 9/12 : 200Ω 3/12 : 500Ω 8/12 : 250Ω 2/12 : 550Ω 7/12 : 300Ω 1/12 : 600Ω Empty warning : 700Ω
Relay (air con blower)		24V 20A	※ Check resistance Normal : About 200Ω (for terminal 1-3) ∞Ω (for terminal 2-4)
Relay	 CR-2 CR-5 CR-36 CR-39 CR-48 CR-50 CR-51 CR-85	24V 16A	※ Check resistance Normal : About 160Ω (for terminal 1-2) 0Ω (for terminal 3-4) ∞Ω (for terminal 3-5)

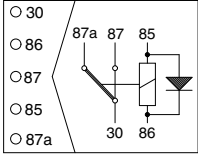
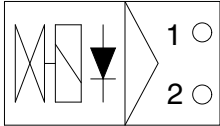
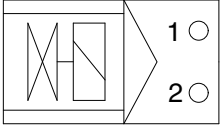
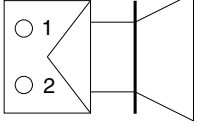
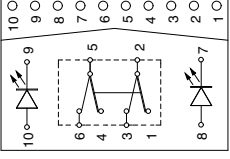
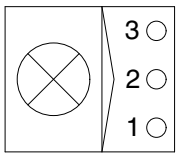
Part name	Symbol	Specifications	Check
Relay	 <p>CR-4 CR-7 CR-9 CR-13 CR-35 CR-46 CR-52</p>	24V 16A	※ Check resistance Normal : About 160 Ω (for terminal 85-86) 0 Ω (for terminal 30-87a) ∞ Ω (for terminal 30-87)
Solenoid valve	 <p>CN-66 CN-68 CN-70 CN-88 CN-135 CN-140 CN-149 CN-150 CN-237 CN-262A CN-262B CN-367 CN-368 CN-369 CN-370 CN-419 CN-420 CN-421</p>	24V 1A	※ Check resistance Normal : 15~25 Ω (for terminal 1-2)
EPPR valve	 <p>CN-81 CN-242 CN-243 CN-309 CN-310 CN-342 CN-343 CN-365 CN-366</p>	700mA	※ Check resistance Normal : 15~25 Ω (for terminal 1-2)
Speaker	 <p>CN-23(LH) CN-260 CN-24(RH)</p>	20W	※ Check resistance Normal : A few Ω
Switch (locking type)	 <p>CS-52 CS-67 CS-73 CS-83 CS-83A (#0042-) CS-99 CS-107 CS-108 CS-111</p>	24V 15A	※ Check contact Normal ON : 0 Ω (for terminal 2-3, 5-6) ∞ Ω (for terminal 2-1, 5-4) OFF : ∞ Ω (for terminal 2-3, 5-6) 0 Ω (for terminal 2-1, 5-4)
Room lamp	 <p>CL-1</p>	24V 10W	※ Check disconnection Normal : 1.0 Ω ON : 0 Ω (For terminal 1-2) ∞ Ω (For terminal 1-3) OFF : ∞ Ω (For terminal 1-2) 0 Ω (For terminal 1-3)

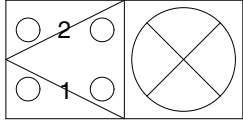
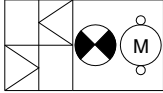
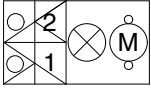
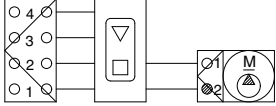
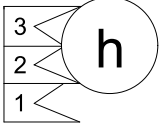
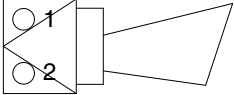
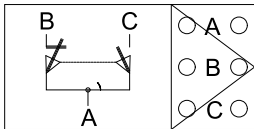
Part name	Symbol	Specifications	Check
Head lamp, Work lamp, Cab lamp	 CL-3 CL-4 CL-5 CL-6 CL-8 CL-9 CL-10 CL-24	24V 65W (H3 Type)	※ Check disconnection Normal : 1.2Ω
Beacon lamp	-#0041  #0042-  CL-7	21V 70W (H1 Type)	※ Check disconnection Normal : A few Ω
Fuel filler pump	 CN-61	24V 10A 35 l /min	※ Check resistance Normal : 1.0Ω
Hour meter	 CN-48	16~32V	※ Check operation Supply power(24V) to terminal No.1 and connect terminal No.2 and ground
Horn	 CN-20 CN-25	DC22~28V 2A	※ Check operation Supply power(24V) to each terminal and connect ground.
Safety switch	 CS-4	24V 15A (N.C TYPE)	※ Check contact Normal : 0Ω (for terminal A-B) ∞Ω (for terminal A-C) Operating : ∞Ω (for terminal A-B) 0Ω (for terminal A-C)

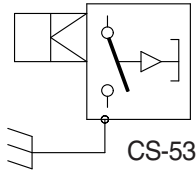
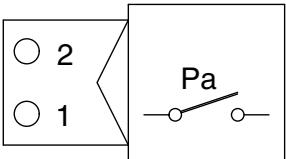
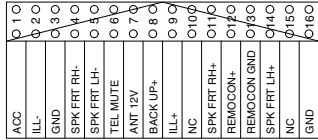
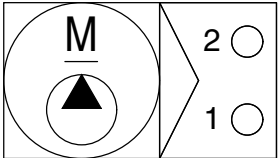
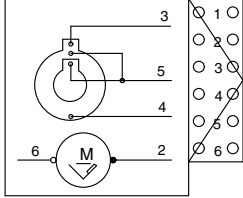
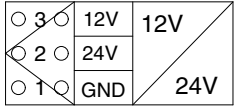
Part name	Symbol	Specifications	Check
Wiper cut switch	 <p>CS-53</p>	24V (N.O TYPE)	※ Check contact Normal : 0Ω (one pin to ground)
Receiver dryer	 <p>CN-29</p>	24V 2.5A	※ Check contact Normal : ∞Ω
Radio & USB player	 <p>CN-27A</p>	24V 2A	※ Check voltage 20~25V (for terminal 1-3, 3-8)
Washer pump	 <p>CN-22 CN-407</p>	24V 3.8A	※ Check contact Normal : 10.7Ω (for terminal 1-2)
Wiper motor	 <p>CN-21</p>	24V 2A	※ Check disconnection Normal : 7Ω (for terminal 2-6)
DC/DC Converter	 <p>CN-138</p>	12V 3A	※ Check voltage 24V (for terminal 1-2) 12V (for terminal 1-3)

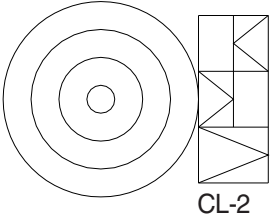
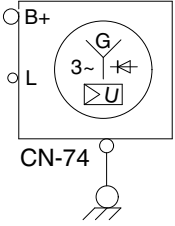
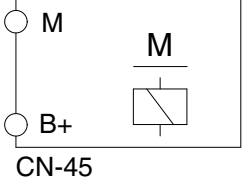
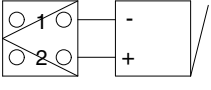
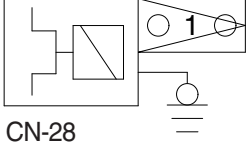
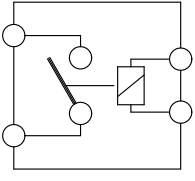

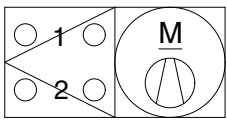
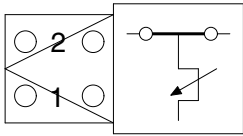
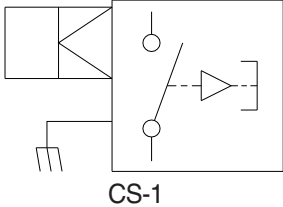
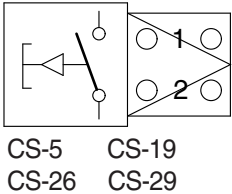
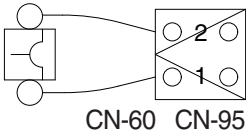
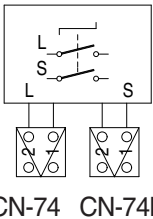
Part name	Symbol	Specifications	Check
Cigar lighter	 <p>CL-2</p>	24V 5A 1.4W	※ Check coil resistance Normal : About 1MΩ ※ Check contact Normal : ∞Ω Operating time : 5~15sec
Alternator	 <p>CN-74</p>	Denso 24V 95A	※ Check contact Normal : 0Ω (for terminal B ⁺ -L) Normal : 24~27.5V
Starter	 <p>CN-45</p>	Denso 24V 4.8kW	※ Check contact Normal : 0.1Ω
Travel alarm	 <p>CN-81</p>	24V 0.5A	※ Check contact Normal : 5.2Ω
Air conditioner compressor	 <p>CN-28</p>	24V 79W	※ Check contact Normal : 13.4Ω
Start relay	 <p>CR-23</p>	24V 300A	※ Check contact Normal : 0.94Ω (for terminal 1-2)

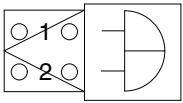
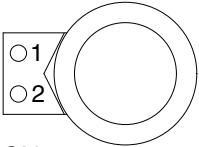
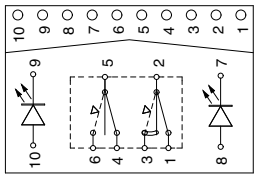
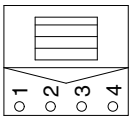
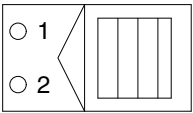
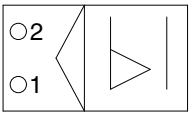
Part name	Symbol	Specifications	Check
Blower motor		24V 9.5A	※ Check resistance Normal : 2.5Ω (for terminal 1-2)
Thermistor (switch)		1°C OFF 4°C ON	※ Check resistance Normal : 0Ω (for terminal 1-2), the atmosphere temp : Over 4°C
Door switch		24V 2W	※ Check resistance Normal : About 5MΩ
Switch (power max, one touch decel, horn, breaker)		24V 6A	※ Check resistance Normal : ∞Ω
Circuit breaker		CN-60 : 60A CN-95 : 90A	※ Check disconnection Normal : 0Ω (connect ring terminal and check resist between terminal 1 and 2)
Master switch		6-36V	※ Check disconnection Normal : 0.1Ω

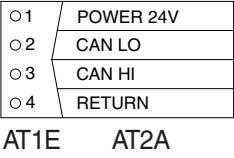
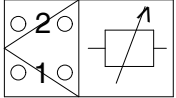
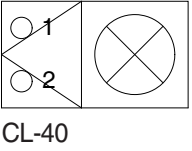
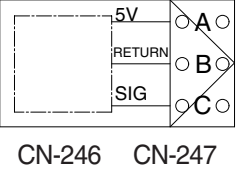
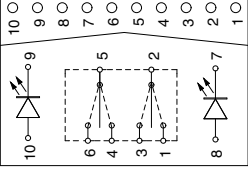
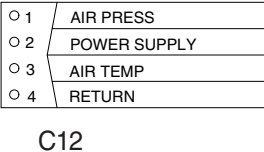
Part name	Symbol	Specifications	Check
Quick coupler buzzer	 <p>CN-113</p>	24V 200mA 107±4dB	-
Socket	 <p>CN-139</p>	12V 10A	-
Switch	 <p>CS-100</p>	24V 8A	※ Check contact Normal ON : 0Ω (for terminal 2-3, 5-6) ∞Ω (for terminal 2-1, 5-4) OFF : ∞Ω (for terminal 2-3, 5-6) 0Ω (for terminal 2-1, 5-4)
Fuel heater	 <p>CN-96</p>	-	-
DEF/AdBlue® line heater	 <p>CN-381 CN-382 CN-383</p>	-	-
WIF sensor	 <p>CD-45</p>	-	-

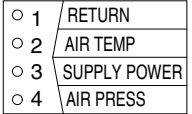
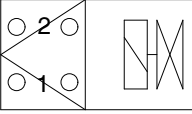
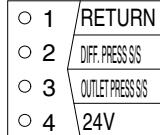
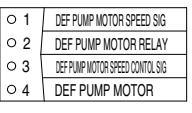
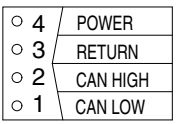
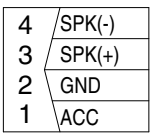
Part name	Symbol	Specifications	Check
Nox sensor		-	-
Temperature sensor (A/C)		-	-
DEF/AdBlue® lamp (LED)		-	-
Proportional valve sensor		-	-
EPPR valve		24V 8A	※ Check contact Normal OFF : ∞ Ω (for terminal 1-2, 4-5)
Sensor		-	-

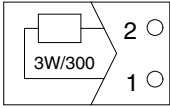
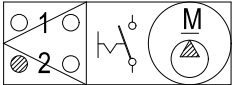
Part name	Symbol	Specifications	Check
Pressure temp sensor	 <p>CD-10</p>	-	
Coolant valve	 <p>CN-384</p>	-	
DPF pressure sensor	 <p>AT11A</p>	-	
SCR and DEF supply module	 <p>AT-5A</p>	-	
Tank level sensor	 <p>CN-380</p>	-	
Siren AMP	 <p>CN-261</p>	-	

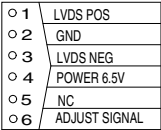
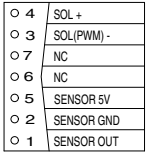
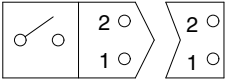
Part name	Symbol	Specifications	Check
Resistor	 <p>RS-1</p>	3W	※ Check resistance Normal : 300Ω
Fuel filler pump	 <p>CN-61</p>	-	
2D/3D MG	 <p>CN-270</p>	-	
Camera (front, rear, side)	 <p>CN-249 CN-402 CN-403 CN-404 CN-405</p>	-	
Fan clutch	 <p>CN-385</p>	-	
Seat belt sw	 <p>CS-250</p>	-	

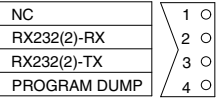
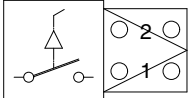
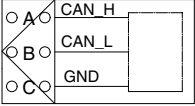
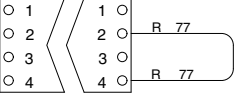
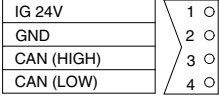
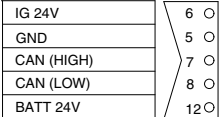
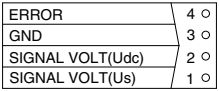
Part name	Symbol	Specifications	Check
RMS service tool	 <p>CN-126A</p>	-	
Breaker switch	 <p>CS-26A</p>	-	
Start button	 <p>CS-2B</p>	-	
GPS connector	 <p>CN-125</p>	-	
Reader	<p>#0041</p>  <p>#0042-</p>  <p>CN-427</p>	-	
Proportional valve	 <p>CN-307</p>	-	

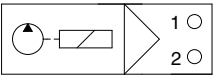
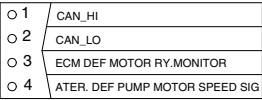
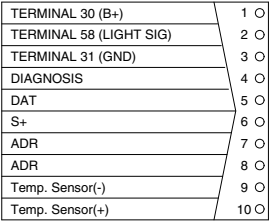
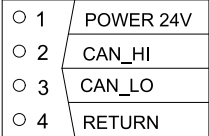
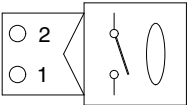
Part name	Symbol	Specifications	Check
Dosing pump	 <p>CN-269</p>	-	
Engine side cross over connector	 <p>CC8C</p>	-	
Easystart timer	 <p>CN-267</p>	-	
Exhaust gas temp sensor	 <p>AT9A</p>	-	
Float switch	 <p>CS-61</p>	-	

GROUP 4 CONNECTORS

1. CONNECTOR DESTINATION

Connector number	Type	No. of pin	Destination	Connector part No.	
				Female	Male
CN-1	AMP	10	l/conn (Frame harness-Pump PS harness)	S816-010002	S816-110002
CN-2	AMP	15	l/conn (Frame harness-Engine harness)	2-85262-1	368301-1
CN-3	TYCO	12	l/conn (Frame harness-Pro vlv harness)	174661-2	368537-1
CN-4	AMP	16	l/conn (Console harness LH-Frame harness)	368047-1	368050-1
CN-5	DEUTSCH	60	l/conn (Frame harness-Side harness RH)	DRB16-60SAE-L018	DRB14-60PAE-L018
CN-6	AMP	16	l/conn (Console harness RH-Frame harness)	368047-1	368050-1
CN-7	AMP	15	l/conn (Console harness RH-Frame harness)	2-85262-1	368301-1
CN-8	AMP	10	l/conn (Console harness RH-Frame harness)	S816-010002	174657-2
CN-9	DEUTSCH	12	l/conn (Frame harness- AAVM harness)	DT06-12SA-P021	DT04-12PA-P021
CN-10	DEUTSCH	12	l/conn (Cab harness-Side harness RH)	DT06-12S-EP06	DT04-12PA-P021
CN-11	DEUTSCH	8	l/conn (Frame harness-Aircon harness)	DT06-8S-EP06	-
CN-12	DEUTSCH	2	l/conn (Frame harness-Boom wire harness)	DT06-2S-EP06	DT04-2P-E005
CN-12	DEUTSCH	2	l/conn (Frame harness-Boom wire 2 pcs)	DT06-2S-EP06	DT04-2P-E004
CN-13	AMP	6	l/conn (Frame harness-Boom floating harness)	174262-2	174264-2
CN-14	AMP	4	l/conn (Frame harness-S/f & parking harness)	174257-2	174259-2
CN-15	AMP	10	l/conn (Frame harness-2-way harness)	174655-2	174657-2
CN-16	AMP	6	Emergency engine start & speed control	S816-006002	S816-106002
CN-17	AMP	8	l/conn (Side harness RH-Wiper harness)	S816-008002	S816-108002
CN-18	AMP	2	Washer tank 2	174352-2	174354-2
CN-20	DEUTSCH	2	Horn	DT06-2S-EP06	-
CN-21	AMP	6	Wiper motor	S810-006202	-
CN-22	KET	2	Washer tank 1	MG640605	-
CN-23	KET	2	Speaker-LH	MG610070	-
CN-24	KET	2	Speaker-RH	MG610070	-
CN-25	DEUTSCH	2	Horn	DT06-2S-EP06	-
CN-27A	KUM	16	Radio & USB player	PK145-16017	-
CN-27B	AMP	8	Radio & USB player	-	174984-2
CN-28	KUM	1	Aircon compressor	MG610320	-
CN-29	KET	2	Receiver dryer	MG640795	-
CN-36	-	-	Fuse & relay box	21Q7-10910	-
CN-45	RING-TERM	-	Starter motor	ST710246-2 S820-31000	ST710384-2 ST710246-2
CN-48	KET	1	Hour meter	2-520193-2	-
CN-51	TE	34	United MCU	2-1473285-3	-
CN-52	TE	34	United MCU	4-1437290-1	-
CN-53	TE	26	United MCU	1473416-1	-
CN-54	TE	34	United MCU	4-1437290-0	-

Connector number	Type	No. of pin	Destination	Connector part No.	
				Female	Male
CN-56A	AMP	12	Cluster	-	174663-2
CN-56B	AMP	8	Cluster	-	174984-2
CN-60	YAZAKI	2	Circuit breaker	-	7222-4220-30
CN-61	DEUTSCH	4	Fuel filler pump	DT06-4S-EP06	DT04-4P-E005
CN-66	DEUTSCH	2	Breaker (A2)	DT06-2S-EP06	-
CN-68	DEUTSCH	2	Safety solenoid (A1)	DT06-2S-EP06	-
CN-70	DEUTSCH	2	Travel high solenoid (A3)	DT06-2S-EP06	-
CN-74	RING-TERM	1	Alternator "B+" terminal	S820-108000	-
CN-74	RING-TERM	1	Alternator "L" terminal	S820-105000	-
CN-80	RING-TERM	-	Glow plug	S820-306000	-
CN-81	DEUTSCH	2	Travel buzzer solenoid	DT06-2S-EP06	-
CN-88	DEUTSCH	2	Power max solenoid (A2)	DT06-2S-EP06	-
CN-93	DELPHI	-	ECM	13964577	-
CN-95	YAZAKI	2	Circuit breaker	-	7222-4220-30
CN-96	AMP	4	Fuel heater	2-967325-3	-
CN-100	KET	1	ECM ground	MG640944-5	-
CN-113	KET	2	Buzzer	MG651205-5	-
CN-125	Econoseal J	4	RMS connector	S816-004002	S816-104002
CN-125A	DEUTSCH	12	RMS	DT06-12S-P021	DT04-12PA-P021
CN-125B	DEUTSCH	8	RMS	DT06-8S	DT04-8P
CN-126	TE/AMP	10	Service tool	1473416-1	S816-110002
CN-126A	DEUTSCH	4	RMS service tool	DT06-4S	DT04-4P
CN-135	DEUTSCH	2	Arm regeneration solenoid (A5)	DT06-2S-EP06	-
CN-138	FASTEN	3	DC/DC Converter	S810-003202	-
CN-139	FASTEN	2	12V socket	172434-2	-
CN-140	DEUTSCH	2	Quick coupler solenoid	DT06-2S-EP06	DT04-2P-E005
CN-141	AMP	13	Wiper motor controller	172498-1	-
CN-147	-	2	Fuel heater	15300027	-
CN-149	DEUTSCH	2	Attachment safety (A1)	DT06-2S-EP06	-
CN-150	DEUTSCH	2	Pedal safety (B)	DT06-2S-EP06	-
CN-156	DEUTSCH	2	Air seat	DT06-2S	DT04-2P
CN-157	AMP	1	Antena power	S822-014002	-
CN-173	DEUTSCH	3	Resistor	DT06-3S-EP06	DT04-3P-EP10
CN-174	DEUTSCH	3	Resistor	DT06-3S-EP06	DT04-3P-EP10
CN-237	DEUTSCH	2	Attachment conflux (A3)	DT06-2S-EP06	-
CN-241	DEUTSCH	2	Travel straight solenoid (A3)	DT06-2S-EP06	-
CN-242	DEUTSCH	2	Boom swing solenoid (A2)	DT06-2S-EP06	-
CN-243	DEUTSCH	2	Boom arm solenoid (A1)	DT06-2S-EP06	-
CN-245	FCI	4	PTC power	180900-0	-

Connector number	Type	No. of pin	Destination	Connector part No.	
				Female	Male
CN-246	DEUTSCH	3	Proportional valve-RH	DT06-3S	DT04-3P
CN-246A	DEUTSCH	4	Preheater harness	DT06-4S-EP06	-
CN-246B	DEUTSCH	4	Preheater harness	-	DT04-4P-EP06
CN-247	DEUTSCH	3	Proportional valve-LH	DT06-3S	DT04-3P
CN-249	DEUTSCH	6	Rear view camera	DT06-6S-EP06	DT04-6P-E005
CN-250	DEUTSCH	2	Auto grease	DT06-2S-EP06	-
CN-258	KET	1	Air compressor power	MG640944-5	MG650943-5
CN-260	MTA	4	Siren speaker	03 01315	-
CN-260	MTA	2	Heater cont (B+)	03 01305	-
CN-261	MTA	4	Siren AMP	MG610047	-
CN-261	MTA	2	Timer cont (B+)	03 01315	-
CN-262	DEUTSCH	2	l/conn (Frame harness - S/travel harness)	DT06-2S-EP06	DT04-2P-E005
CN-262A	DEUTSCH	2	Straight travel solenoid 1	DT06-2S-EP06	-
CN-262B	DEUTSCH	2	Straight travel solenoid 2	DT06-2S-EP06	-
CN-263	DEUTSCH	2	Air compressor relay	DT06-2S-EP06	DT04-2P-E005
CN-265	VW	8	Controller	3A0973734	-
CN-267	MOLEX	10	Preheater timer	15-97-5101	-
CN-269	TE	2	Dosing pump	282189-1	-
CN-270	DEUTSCH	4	2D/3D MG	DT06-4S-EP06	DT04-4P-E005
CN-305	DEUTSCH	12	Proportional-connector-1	DTM06-12SA	-
CN-306	DEUTSCH	12	Proportional-connector-2	DTM06-12SB	-
CN-307	DEUTSCH	3	Proportional-service tool	DT06-3S-EP06	DT06-3P-E005
CN-307	AMP	4	Proportional-PVG32	2-967059-1	-
CN-309	DEUTSCH	2	Proportional-EPPR valve-A1	DT06-2S-EP06	-
CN-310	DEUTSCH	2	Proportional-EPPR valve-A2	DT06-2S-EP06	-
CN-342	AMP	2	P1 pump regulator solenoid	S816-002002	-
CN-343	AMP	2	P2 pump regulator solenoid	S816-002002	-
CN-363	AMP	12	Jog dial module	174045-2	-
CN-365	DEUTSCH	2	Attach EPPR valve-LH	DT06-2S-EP06	DT04-2P-E005
CN-366	DEUTSCH	2	Attach EPPR valve-RH	DT06-2S-EP06	DT04-2P-E005
CN-367	AMP	2	Boom down floating solenoid	85202-1	DT04-2P-E005
CN-368	DEUTSCH	2	Boom up floating solenoid	DT06-2S-EP06	DT04-2P-E005
CN-369	DEUTSCH	2	Boom down cut off solenoid	DT06-2S-EP06	DT04-2P-E005
CN-370	DEUTSCH	2	Swing fine control solenoid	DT06-2S-EP06	DT04-2P-E005
CN-376	TYCO	23	Membrane controller	7706087-2	-
CN-380	DEUTSCH	4	DEF tank level sensor	DT06-4S-EP06	-
CN-381	DEUTSCH	2	DEF line heater 3	DT06-2S-EP06	-
CN-382	DEUTSCH	2	DEF line heater 2	DT06-2S-EP06	-
CN-383	DEUTSCH	2	DEF line heater 1	DT06-2S-EP06	-

Connector number	Type	No. of pin	Destination	Connector part No.	
				Female	Male
CN-384	TE	2	Coolant valve solenoid	1-967325-3	-
CN-385	-	7	Fan clutch	965570	-
CN-401	TE	35	AAVM controller	776164-1	-
CN-402	DEUTSCH	6	Front view camera	DT06-6S-P021	DT04-6P-P021
CN-403	DEUTSCH	6	Rear view camera	DT06-6S-EP06	DT04-6P-EP14
CN-404	DEUTSCH	6	LH view camera	DT06-6S-EP06	DT04-6P-EP14
CN-405	DEUTSCH	6	RH view camera	DT06-6S-EP06	DT04-6P-EP14
CN-406	DEUTSCH	3	Service tool	DT06-3S-EP05	DT04-3P-E005
CN-407	DEUTSCH	4	Low wiper motor	DT06-4S-EP06	DT04-4P-E005
CN-419	DEUTSCH	2	Swing parking-A1	DT06-2S-EP06	-
CN-420	DEUTSCH	2	Swing parking-A2	DT06-2S-EP06	-
CN-421	DEUTSCH	2	Swing parking-A3	DT06-2S-EP06	-
CN-427	MOLEX	4	Reader-RMS	039012040	026013096
		12		5557-12R	5559-12P
CN-430	AMP/Econoseal J	12	I/conn (Frame harness - DEF harness)	174661	S816-112002
AT-1E	TYCO	4	DOC NOx sensor (inlet)	2-1418390-1	-
AT-2A	TYCO	4	SCR NOx sensor (outlet)	1-1418390-1	-
AT-5A	TYCO	4	SCR supply module	2-418390-1	-
AT-6A	TYCO	8	DEF dosing module	1-1418479-1	-
AT-9A	TYCO	4	SCR temperature sensor	4-1418390-1	-
AT-11A	DELPHI	4	DEF pressure sensor	F715600	-
C12	FCI	4	Air cleaner	-	54200419
CC8C	DEUTSCH	4	Cross over connector - Engine side	DT06-4S-EP06	-
· Relay					
CR-1	RING-TERM	-	Battery relay	ST710289-2	-
CR-2	-	5	Horn relay	-	-
CR-4	-	5	Working lamp relay	-	-
CR-5	-	5	Anti restart relay	-	-
CR-7	-	5	Aircon compressor relay	-	-
CR-9	-	5	Cabin lamp relay	-	-
CR-13	-	5	Head lamp relay	-	-
CR-23	KET	2	Start relay	MG610320	S814-102001
CR-24	RING TERM	1	Preheat relay	S822-014000	-
CR-35	-	5	Power relay	-	-
CR-36	-	5	Preheat relay	-	-
CR-39	-	5	Starter lock out relay	-	-
CR-46	-	5	Fuel warmer relay	-	-
CR-48	-	5	Safety relay	-	-
CR-50	-	5	NOx sensor relay	-	-

Connector number	Type	No. of pin	Destination	Connector part No.	
				Female	Male
CR-51	-	5	DEF module relay	-	-
CR-52	-	5	Line heater relay	-	-
CR-85	-	5	Beacon lamp relay	-	-
· Switch					
CS-1	SHUR	1	Door switch	S822-014002	S822-114002
CS-2A	WP	6	Start switch	S814-006100	-
CS-2B	DEUTSCH	3	Start button	DT06-3S-EP06	DT04-3P-E005
CS-2C	KET	3	BKCU	MG651032	-
CS-2D	KET	3	Button key	-	M6641035
CS-4	DEUTSCH	3	Safety switch	DT06-3S	-
CS-5	DEUTSCH	2	Horn switch	-	DT04-2P
CS-19	DEUTSCH	2	One touch decel switch	-	DT04-2P
CS-26	DEUTSCH	2	Breaker switch	DT06-2S	-
CS-26A	AMP	2	Breaker pedal switch	S816-002002	S816-102002
CS-29	DEUTSCH	2	Power max switch	DT06-2S	-
CS-33	AMP	5	Emergency engine stop switch	S816-005002	S816-105002
CS-52	CARLING	10	Adjust & dozer switch	VC2-01	-
CS-53	AMP	1	Wiper cut switch	S822-014002	-
CS-61	AMP	2	Floating switch	174352-2	174354-2
CS-67	CARLING	10	Quick coupler switch	VC2-01	-
CS-73	CARLING	10	Swing lock switch	VC2-01	-
CS-73A	CARLING	10	Fine swing switch	VC2-01	-
CS-74	DEUTSCH	2	Master switch	DT06-2S-EP06	-
CS-74A	TYCO/KET	2	Power connector	7706087-2	MG610557
CS-74B	DEUTSCH	2	Master switch	DT06-2S-EP06	-
CS-79	CARLING	10	Lower wiper switch	VC2-01	-
CS-99	CARLING	10	Air compressor switch	VC2-01	-
CS-100	CARLING	10	SCR system cleaning switch	VC2-01	-
CS-107	CARLING	10	Travel straight switch	VC2-01	-
CS-108	CARLING	10	Auto grease switch	VC2-01	-
CS-111	CARLING	10	Boom floating switch	VC2-01	-
CS-250	DEUTSCH	2	Seat switch	DT06-2S	-
· Light					
CL-1	KET	3	Room lamp	MG651032	-
CL-2	AMP	1	Cigar lighter	S822-014002	S822-114002
CL-2	AMP	1	Cigar lighter	S810-001202	-
CL-3	DEUTSCH	2	Head lamp-LH	DT06-2S-EP06	-
CL-4	DEUTSCH	2	Head lamp-RH	DT06-2S-EP06	-
CL-5	DEUTSCH	2	Work lamp-LH	DT06-2S-EP06	-

Connector number	Type	No. of pin	Destination	Connector part No.	
				Female	Male
CL-6	DEUTSCH	2	Work lamp-RH	DT06-2S-EP06	-
CL-7	SHUR	1	Beacon lamp	S822-014002	S822-114002
CL-8	DEUTSCH	2	Cab lighter-LH	DT06-2S-EP06	DT04-2P
CL-9	DEUTSCH	2	Cab lighter-RH	DT06-2S-EP06	DT04-2P
CL-10	DEUTSCH	2	Cab lighter-RH	DT06-2S-EP06	DT04-2P
CL-24	DEUTSCH	2	Head lamp - rear	DT06-2S-EP06	DT04-2P-E005
CL-40	DEUTSCH	2	DEF/AdBlue® purging lamp	DT06-2S-EP06	DT04-2P
· Sensor, sendor					
CD-1	AMP	2	Hydraulic oil temp sender	85202-1	-
CD-2	DEUTSCH	2	Fuel sender	DT06-2S-EP06	-
CD-6	DEUTSCH	3	Travel pilot pressure sw (Py)	DT06-3S-EP06	-
CD-7	DEUTSCH	3	Travel pilot pressure sw (Px)	DT06-3S-EP06	-
CD-10	SUMITOMO	4	Air cleaner switch	6908-0144	-
CD-10A	AMP	2	Air cleaner switch	85202-1	-
CD-16	AMP	3	Water level sensor	1211 0293	-
CD-24	DEUTSCH	3	Swing pilot pressure sw	DT06-3S-EP06	-
CD-31	DEUTSCH	3	Overload pressure sensor	DT06-3S-EP06	DT04-3P-E005
CD-32	DEUTSCH	3	Boom up pilot pressure sw	DT06-3S-EP06	-
CD-37	DEUTSCH	3	2 pcs boom perssure switch	DT06-3S-EP06	DT04-3P-E005
CD-42	DEUTSCH	3	P1 pump delivery pressure sw	DT06-3S-EP06	-
CD-43	DEUTSCH	3	P2 pump delivery pressure sw	DT06-3S-EP06	-
CD-45	DEUTSCH	2	WIF sensor	DT06-2S-EP06	-
CD-69	DEUTSCH	3	Attach pressure sensor	DT06-3S-EP06	-
CD-70	DEUTSCH	3	N1 regulator pressure sensor (A4)	DT06-3S-EP06	-
CD-71	DEUTSCH	3	N2 regulator pressure sensor (A5)	DT06-3S-EP06	-
CD-85	DEUTSCH	3	Boom down pilot pressure sw	DT06-3S-EP06	-
CD-86	DEUTSCH	3	Arm out pilot pressure sw	DT06-3S-EP06	-
CD-87	DEUTSCH	3	Bucket out pilot pressure sw	DT06-3S-EP06	-
CD-90	DEUTSCH	3	Arm in pilot pressure sw	DT06-3S-EP06	-
CD-104	DEUTSCH	3	RH travel pilot pressure sw	DT06-3S-EP06	-
CD-105	DEUTSCH	3	LH travel pilot pressure sw	DT06-3S-EP06	-
CD-124	DEUTSCH	3	Boom cylinder rod pressure sensor	DT06-3S-EP06	-
CD-130	DEUTSCH	3	Bucket in pilot pressure sw	DT06-3S-EP06	-

2. CONNECTION TABLE FOR CONNECTORS

1) PA TYPE CONNECTOR

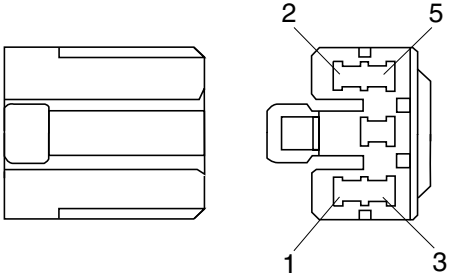
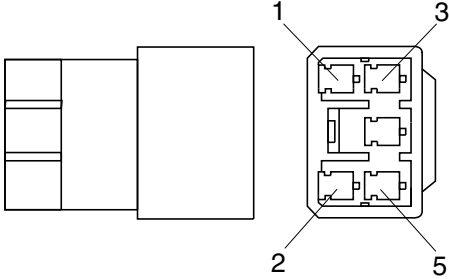
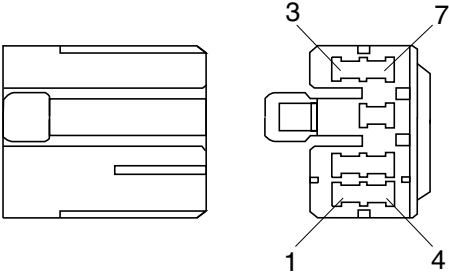
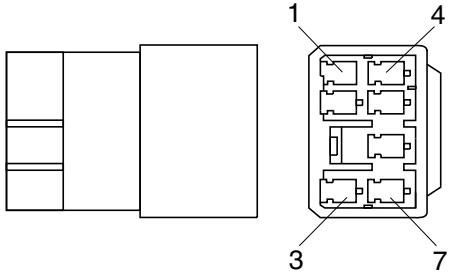
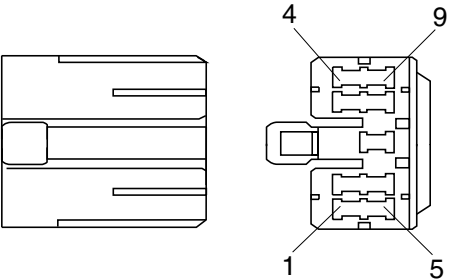
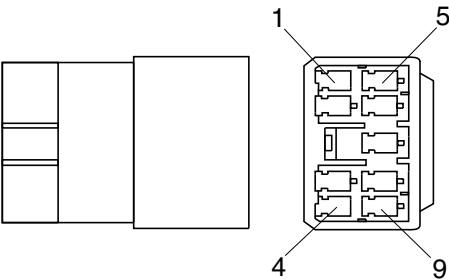
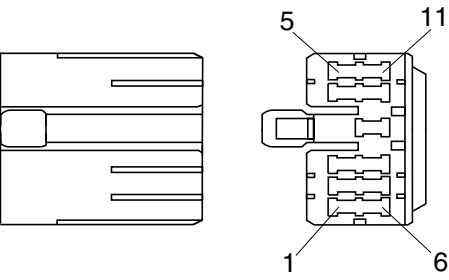
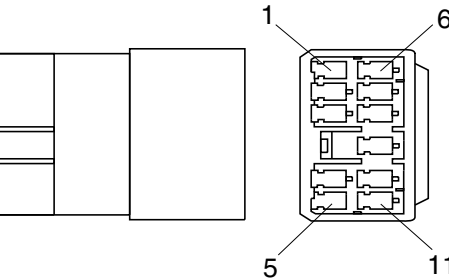
No. of pin	Receptacle connector (female)	Plug connector (male)
5	 <p style="text-align: center;">S811-005002</p>	 <p style="text-align: center;">S811-105002</p>
7	 <p style="text-align: center;">S811-007002</p>	 <p style="text-align: center;">S811-107002</p>
9	 <p style="text-align: center;">S811-009002</p>	 <p style="text-align: center;">3S811-109002</p>
11	 <p style="text-align: center;">S811-011002</p>	 <p style="text-align: center;">S811-111002</p>

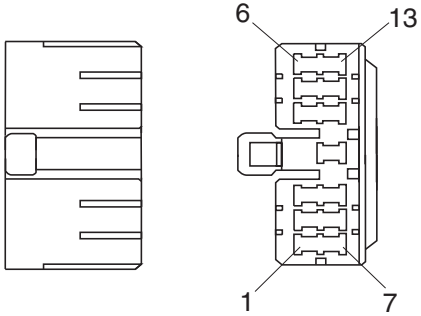
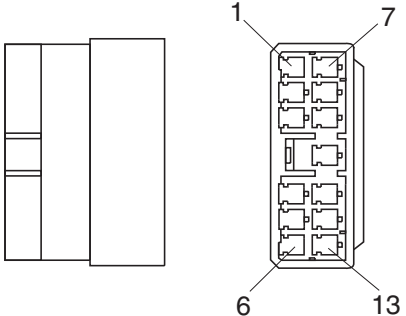
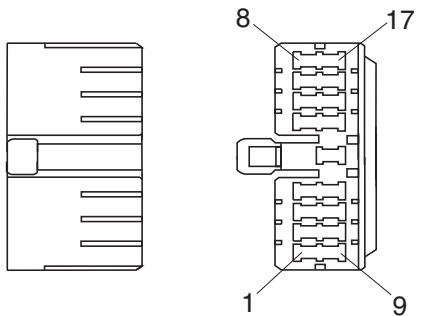
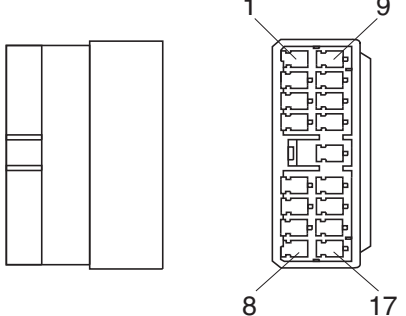
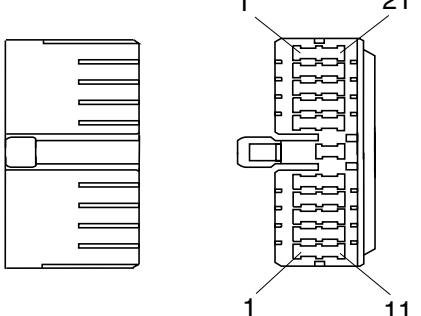
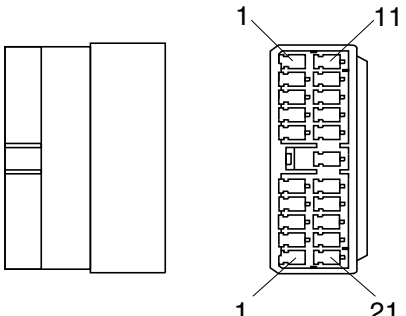
No. of pin	Receptacle connector (female)	Plug connector (male)
13	 <p data-bbox="686 638 837 672">S811-013002</p>	 <p data-bbox="1244 638 1396 672">S811-113002</p>
17	 <p data-bbox="686 1041 837 1075">S811-017002</p>	 <p data-bbox="1244 1041 1396 1075">S811-117002</p>
21	 <p data-bbox="686 1444 837 1478">S811-021002</p>	 <p data-bbox="1244 1444 1396 1478">S811-121002</p>

2) J TYPE CONNECTOR

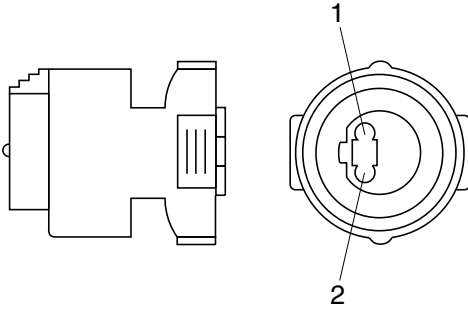
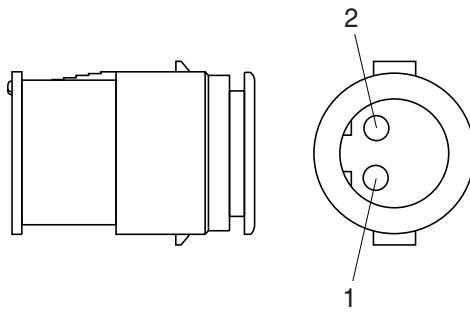
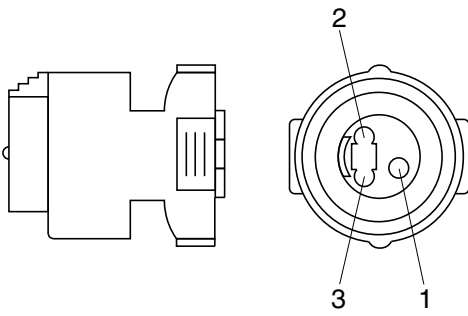
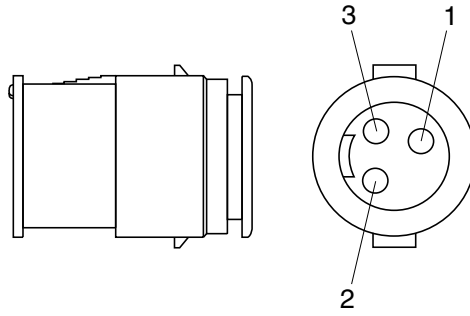
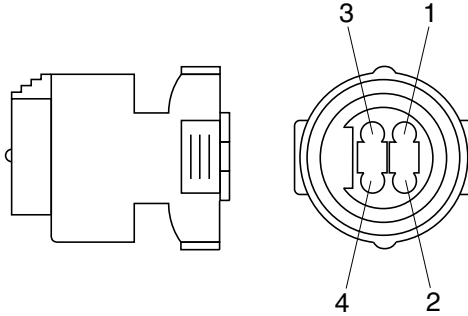
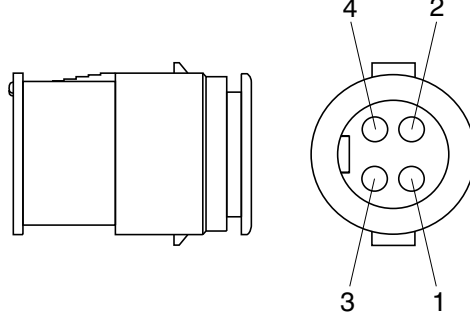
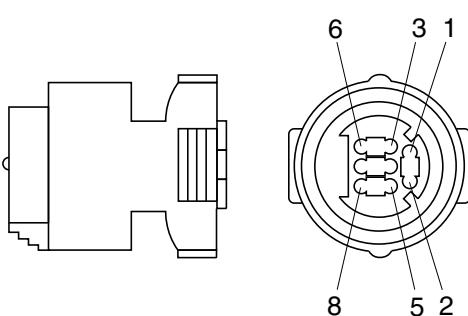
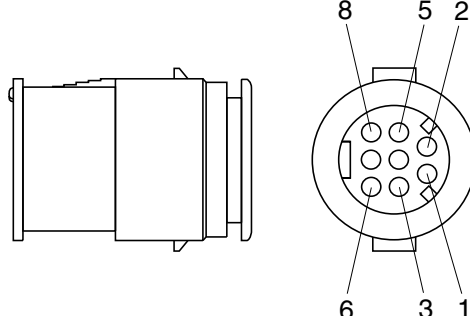
No. of pin	Receptacle connector (female)	Plug connector (male)
2	 <p style="text-align: center;">S816-002001</p>	 <p style="text-align: center;">S816-102001</p>
3	 <p style="text-align: center;">S816-003001</p>	 <p style="text-align: center;">S816-103001</p>
4	 <p style="text-align: center;">S816-004001</p>	 <p style="text-align: center;">S816-104001</p>
8	 <p style="text-align: center;">S816-008001</p>	 <p style="text-align: center;">S816-108001</p>

3) SWP TYPE CONNECTOR

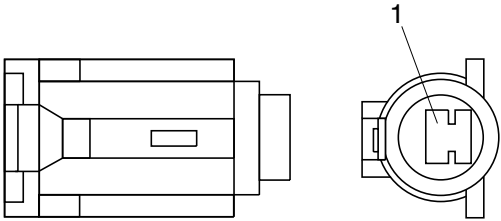
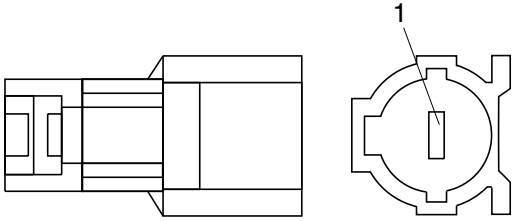
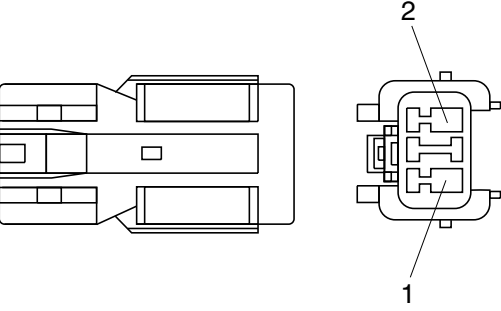
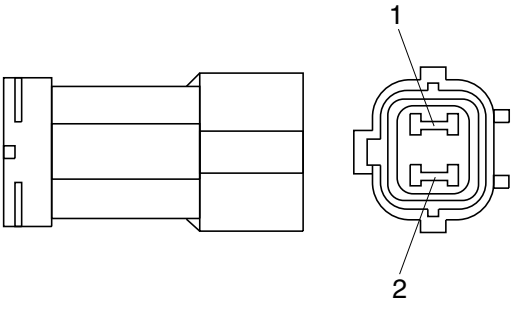
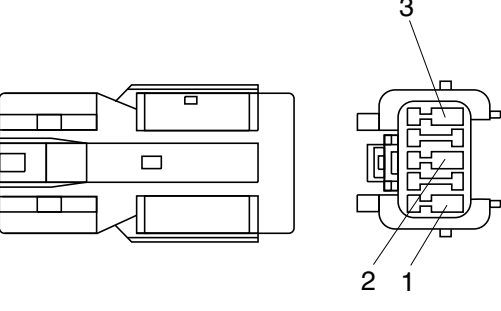
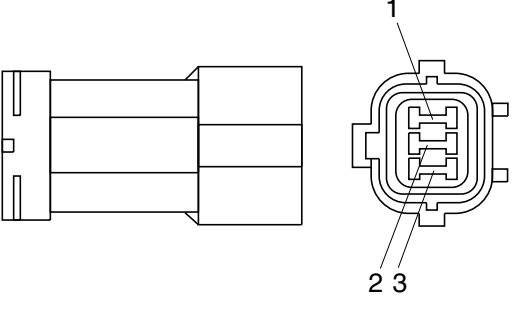
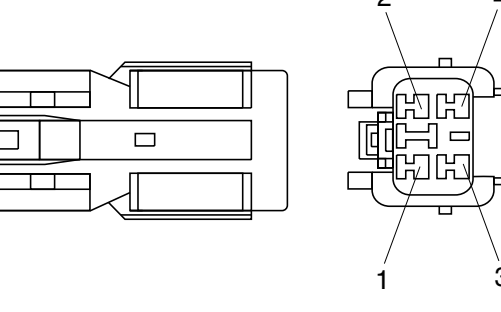
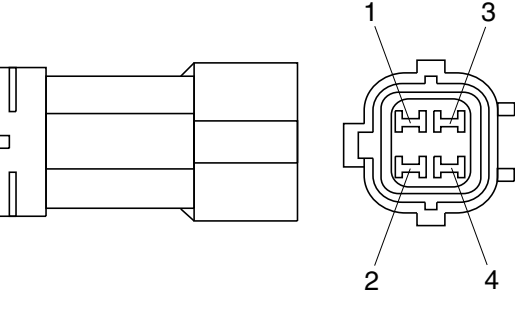
No. of pin	Receptacle connector (female)	Plug connector (male)
1	 <p data-bbox="687 680 836 707">S814-001000</p>	 <p data-bbox="1241 680 1390 707">S814-101000</p>
2	 <p data-bbox="687 1084 836 1111">S814-002000</p>	 <p data-bbox="1241 1084 1390 1111">S814-102000</p>
3	 <p data-bbox="687 1494 836 1520">S814-003000</p>	 <p data-bbox="1241 1494 1390 1520">S814-103000</p>
4	 <p data-bbox="687 1904 836 1930">S814-004000</p>	 <p data-bbox="1241 1904 1390 1930">S814-104000</p>

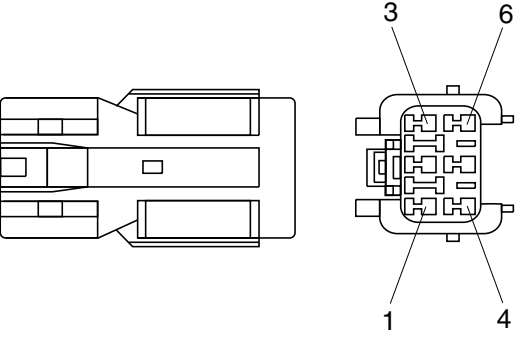
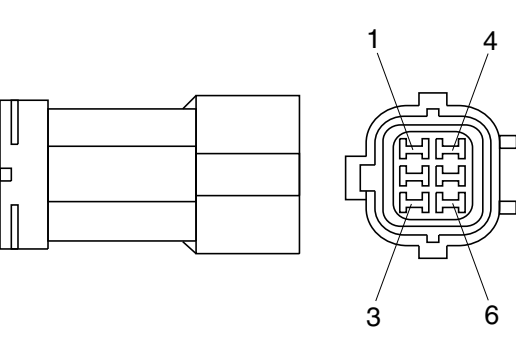
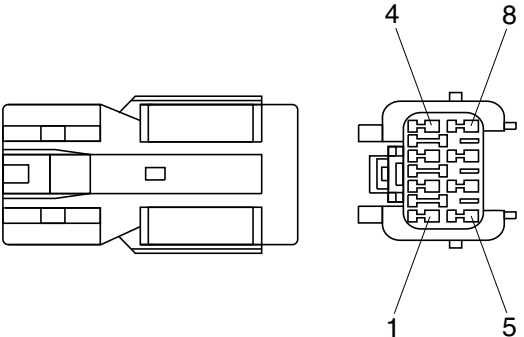
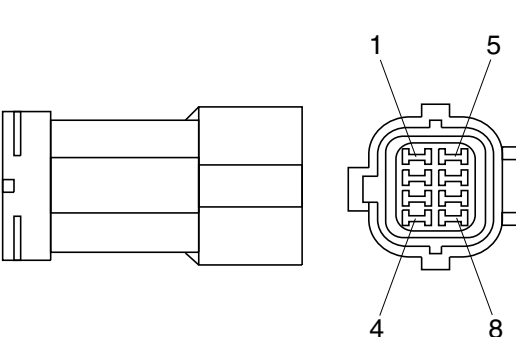
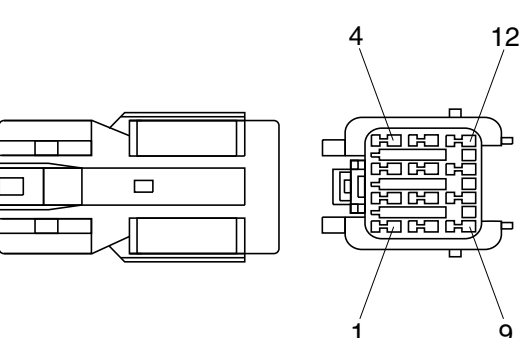
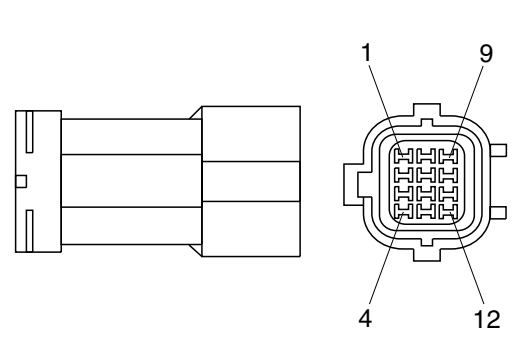
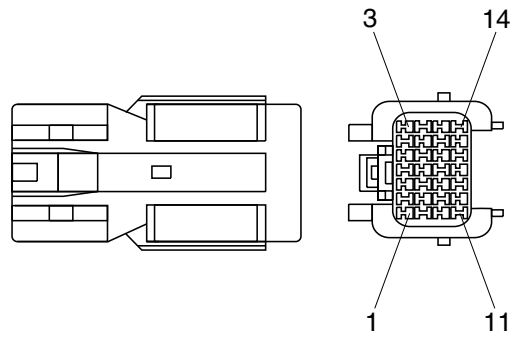
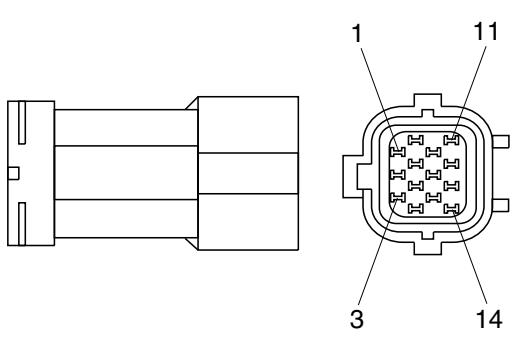
No. of pin	Receptacle connector (female)	Plug connector (male)
6	 <p data-bbox="686 638 837 672">S814-006000</p>	 <p data-bbox="1244 638 1396 672">S814-106000</p>
8	 <p data-bbox="686 1041 837 1075">S814-008000</p>	 <p data-bbox="1244 1041 1396 1075">S814-108000</p>
12	 <p data-bbox="686 1449 837 1482">S814-012000</p>	 <p data-bbox="1244 1449 1396 1482">S814-112000</p>
14	 <p data-bbox="686 1856 837 1890">S814-014000</p>	 <p data-bbox="1244 1856 1396 1890">S814-114000</p>

4) CN TYPE CONNECTOR

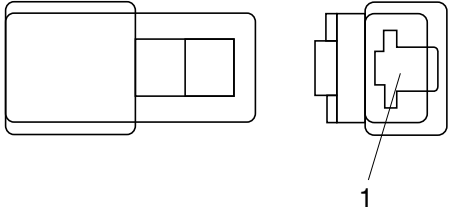
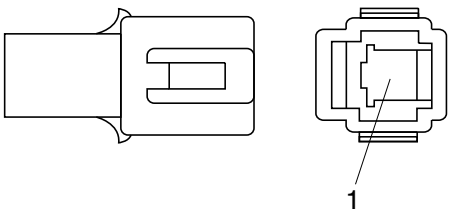
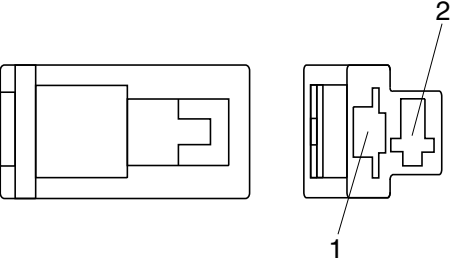
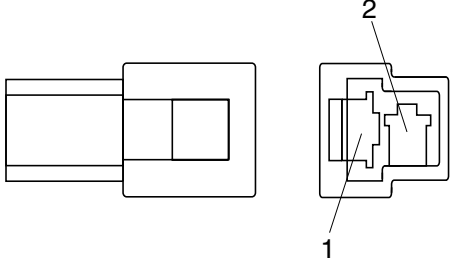
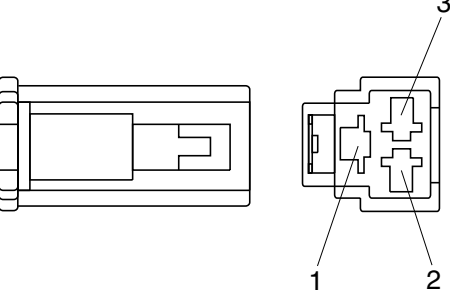
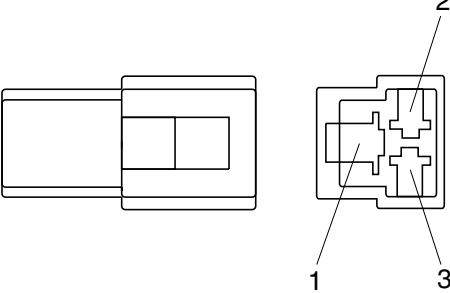
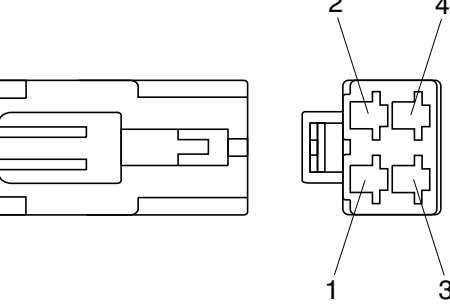
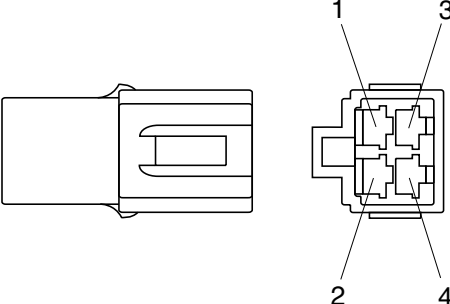
No. of pin	Receptacle connector (female)	Plug connector (male)
1	 <p style="text-align: center;">S810-001202</p>	 <p style="text-align: center;">S810-101202</p>
2	 <p style="text-align: center;">S810-002202</p>	 <p style="text-align: center;">S810-102202</p>
3	 <p style="text-align: center;">S810-003202</p>	 <p style="text-align: center;">S810-103202</p>
4	 <p style="text-align: center;">S810-004202</p>	 <p style="text-align: center;">S810-104202</p>

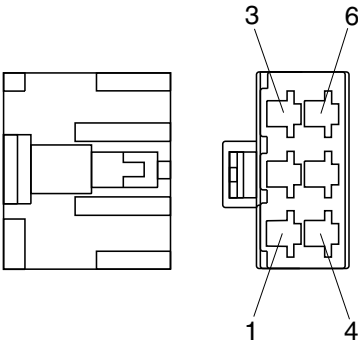
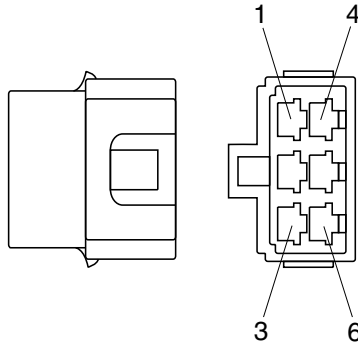
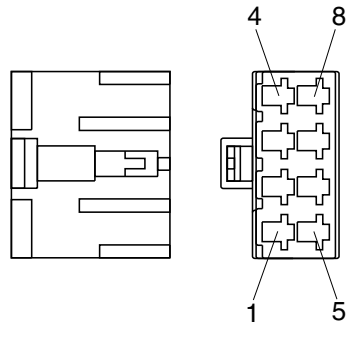
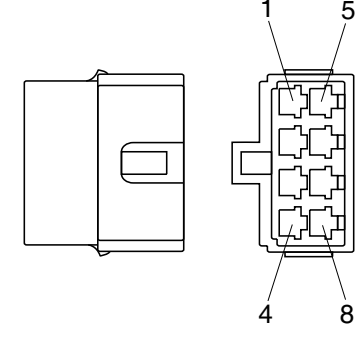
No. of pin	Receptacle connector (female)	Plug connector (male)
6	 <p data-bbox="686 638 837 672">S810-006202</p>	 <p data-bbox="1244 638 1396 672">S810-106202</p>
8	 <p data-bbox="686 1041 837 1075">S810-008202</p>	 <p data-bbox="1244 1041 1396 1075">S810-108202</p>

5) 375 FASTEN TYPE CONNECTOR

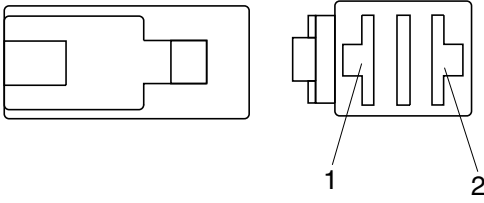
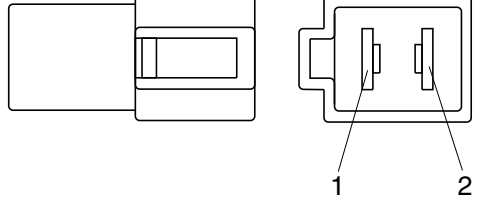
No. of pin	Receptacle connector (female)	Plug connector (male)
2	 <p style="text-align: center;">S810-002402</p>	 <p style="text-align: center;">S810-102402</p>

6) AMP ECONOSEAL CONNECTOR

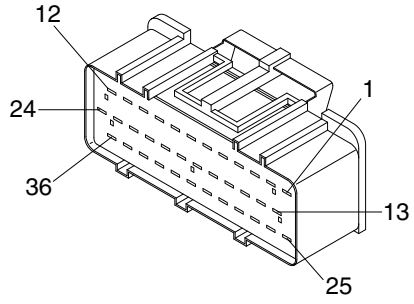
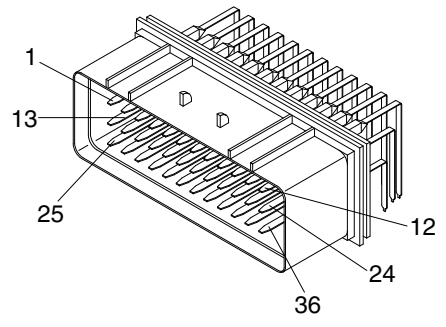
No. of pin	Receptacle connector (female)	Plug connector (male)
36	 <p style="text-align: center;">344111-1</p>	 <p style="text-align: center;">344108-1</p>

7) AMP TIMER CONNECTOR

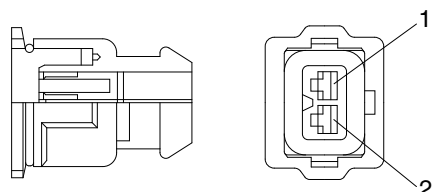
No. of pin	Receptacle connector (female)	Plug connector (male)
2	 <p style="text-align: center;">85202-1</p>	

8) AMP 040 MULTILOCK CONNECTOR

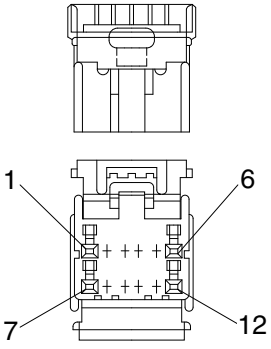
No. of pin	Receptacle connector (female)	Plug connector (male)
12	 <p style="text-align: right;">174045-2</p>	

9) AMP 070 MULTILOCK CONNECTOR

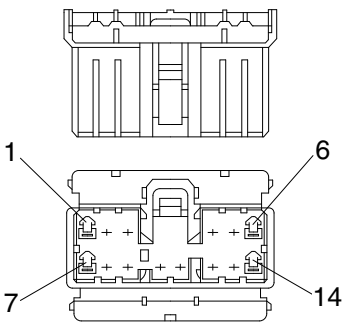
No. of pin	Receptacle connector (female)	Plug connector (male)
14	 <p style="text-align: right;">173852</p>	

10) AMP FASTIN - FASTON CONNECTOR

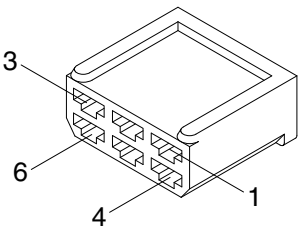
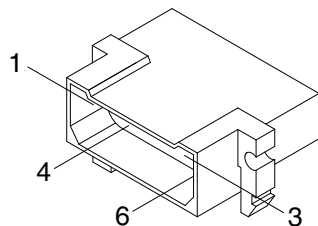
No. of pin	Receptacle connector (female)	Plug connector (male)
6	 <p style="text-align: right;">925276-0</p>	 <p style="text-align: right;">480003-9</p>

11) KET 090 CONNECTOR

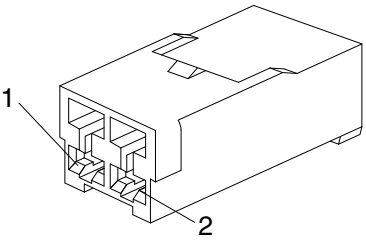
No. of pin	Receptacle connector (female)	Plug connector (male)
2	 <p style="text-align: right;">MG610070</p>	

12) KET 090 WP CONNECTORS

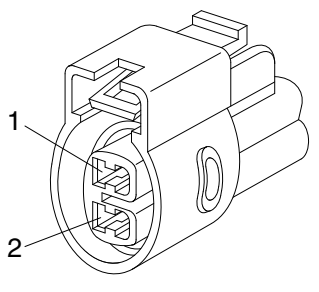
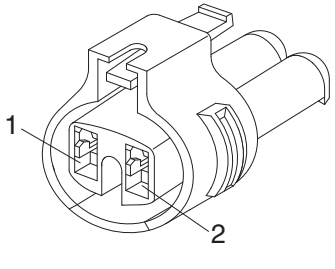
No. of pin	Receptacle connector (female)	Plug connector (male)
2	 <p style="text-align: right;">MG640605</p>	
2	 <p style="text-align: right;">MG640795</p>	

13) KET SDL CONNECTOR

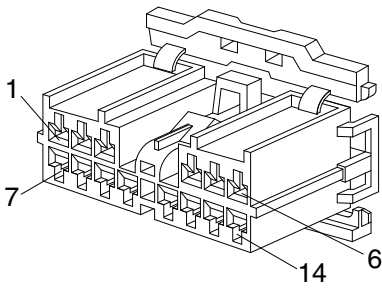
No. of pin	Receptacle connector (female)	Plug connector (male)
14	 <p data-bbox="710 672 837 705">MG610406</p>	

14) DEUTSCH DT CONNECTORS

DT 06 - 3S - ★★☆☆

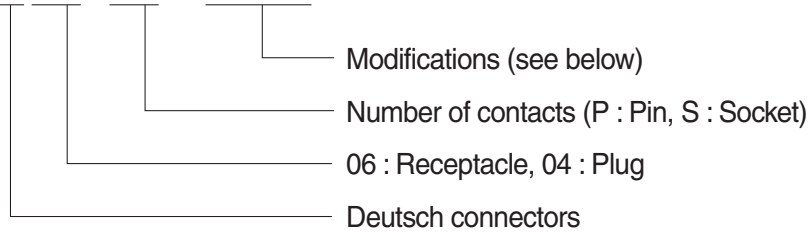

※ Modification

E003 : Standard end cap - gray

E004 : Color of connector to be black

E005 : Combination - E004 & E003

EP04 : End cap

EP06 : Combination P012 & EP04

P012 : Front seal enhancement - connectors color to black for 2, 3, 4 & 6pin

No. of pin	Receptacle connector (female)	Plug connector (male)
2	<p>DT06-2S</p>	<p>DT04-2P</p>
3	<p>DT06-3S</p>	<p>DT04-3P</p>
4	<p>DT06-4S</p>	<p>DT04-4P</p>

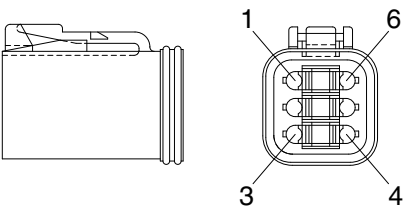
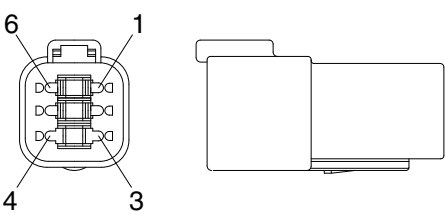
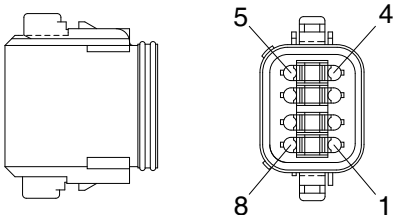
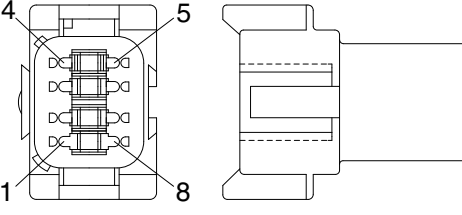
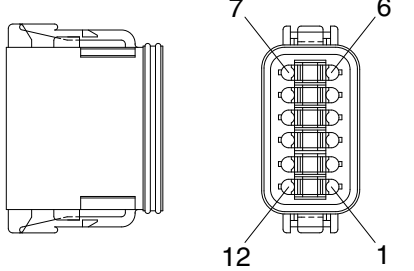
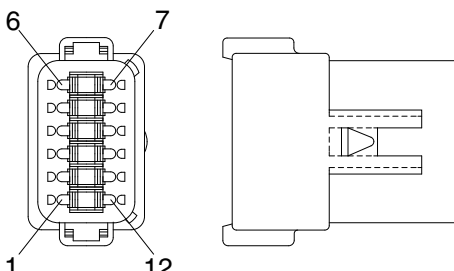
No. of pin	Receptacle connector (female)	Plug connector (male)
6	 <p style="text-align: center;">DT06-6S</p>	 <p style="text-align: center;">DT04-6P</p>
8	 <p style="text-align: center;">DT06-8S</p>	 <p style="text-align: center;">DT04-8P</p>
12	 <p style="text-align: center;">DT06-12S</p>	 <p style="text-align: center;">DT04-12P</p>

15) MOLEX 2CKTS CONNECTOR

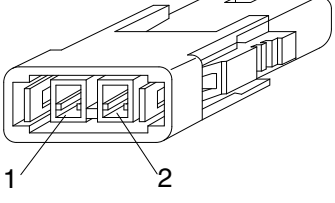
No. of pin	Receptacle connector (female)	Plug connector (male)
2	 <p data-bbox="702 683 837 705">35215-0200</p>	

16) ITT SWF CONNECTOR

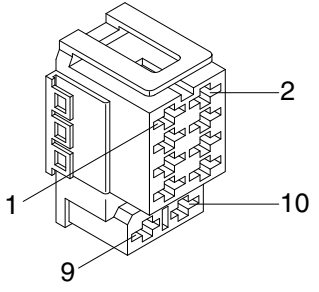
No. of pin	Receptacle connector (female)	Plug connector (male)
10	 <p data-bbox="694 1288 837 1310">SWF593757</p>	

17) MWP NMWP CONNECTOR

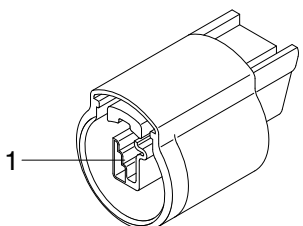
No. of pin	Receptacle connector (female)	Plug connector (male)
1	 <p data-bbox="686 1892 837 1915">NMWP01F-B</p>	

18) ECONOSEAL J TYPE CONNECTORS

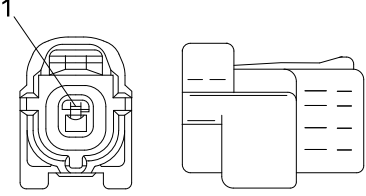
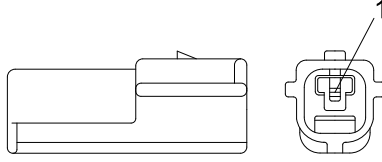
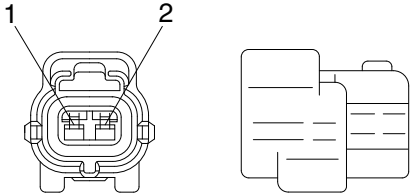
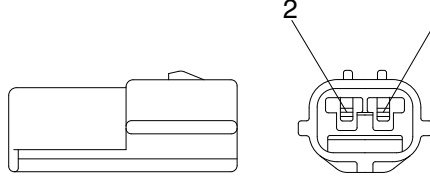
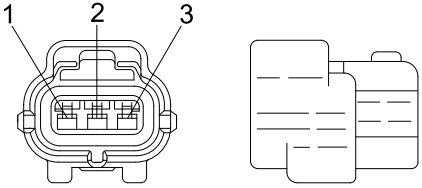
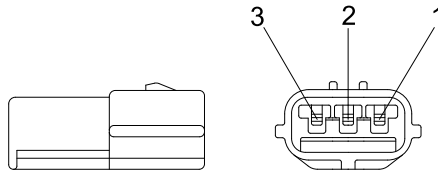
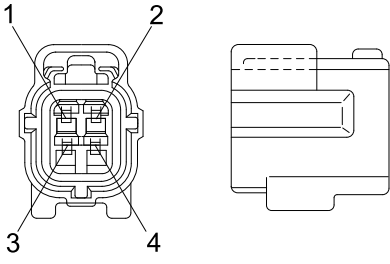
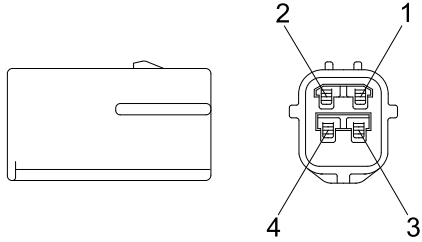
No. of pin	Receptacle connector (female)	Plug connector (male)
1	 <p style="text-align: center;">S816-001002</p>	 <p style="text-align: center;">S816-101002</p>
2	 <p style="text-align: center;">S816-002002</p>	 <p style="text-align: center;">S816-102002</p>
3	 <p style="text-align: center;">S816-003002</p>	 <p style="text-align: center;">S816-103002</p>
4	 <p style="text-align: center;">S816-004002</p>	 <p style="text-align: center;">S816-104002</p>

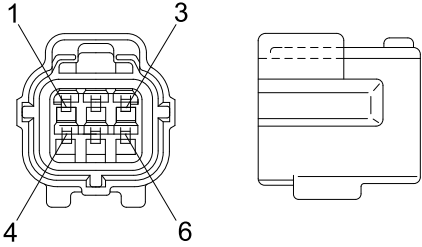
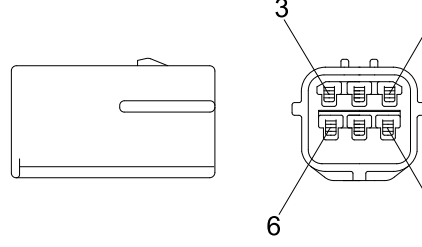
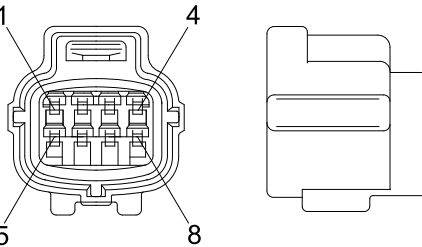
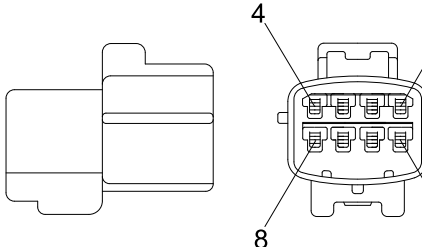
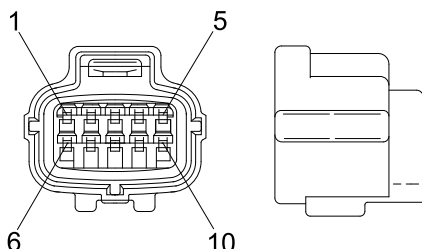
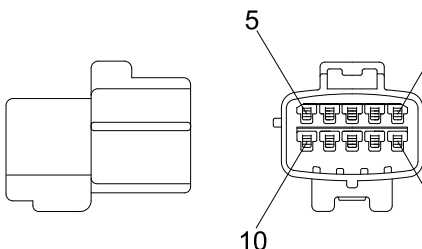
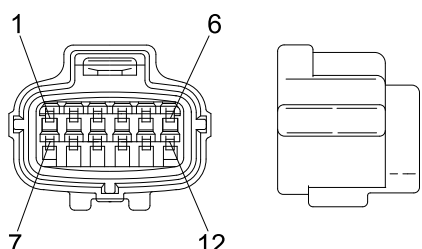
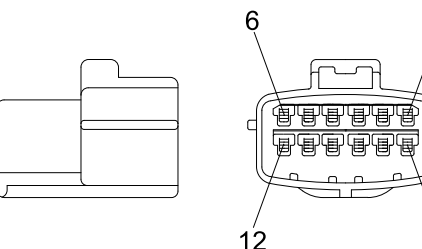
No. of pin	Receptacle connector (female)	Plug connector (male)
6	 <p style="text-align: center;">S816-006002</p>	 <p style="text-align: center;">S816-106002</p>
8	 <p style="text-align: center;">S816-008002</p>	 <p style="text-align: center;">S816-108002</p>
10	 <p style="text-align: center;">S816-010002</p>	 <p style="text-align: center;">S816-110002</p>
12	 <p style="text-align: center;">S816-012002</p>	 <p style="text-align: center;">S816-112002</p>

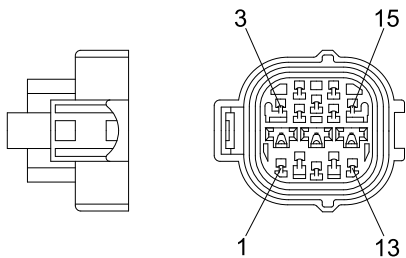
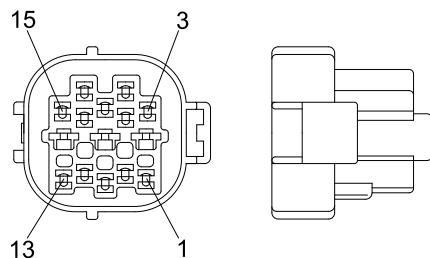
No. of pin	Receptacle connector (female)	Plug connector (male)
15	 <p data-bbox="730 633 834 663">368301-1</p>	 <p data-bbox="1278 633 1382 663">2-85262-1</p>

19) METRI-PACK TYPE CONNECTOR

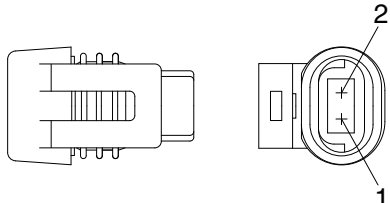
No. of pin	Receptacle connector (female)	Plug connector (male)
2	 <p data-bbox="726 1236 829 1265">12040753</p>	

20) DEUTSCH HD30 CONNECTOR

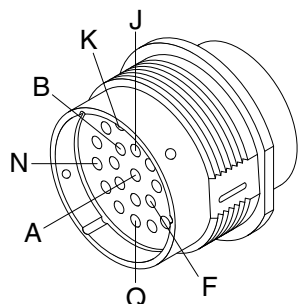
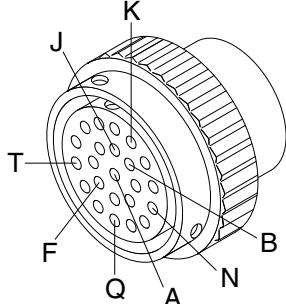
No. of pin	Receptacle connector (female)	Plug connector (male)
23	 <p data-bbox="667 1839 834 1868">HD36-24-23SN</p>	 <p data-bbox="1222 1839 1390 1868">HD34-24-23PN</p>

21) DEUTSCH SERVICE TOOL CONNECTOR

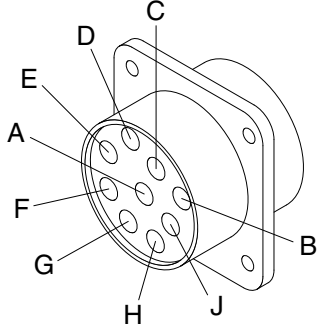
No. of pin	Receptacle connector (Female)	Plug connector (Male)
9	 <p style="text-align: right;">HD10-9-96P</p>	

22) AMP FUEL WARMER CONNECTOR

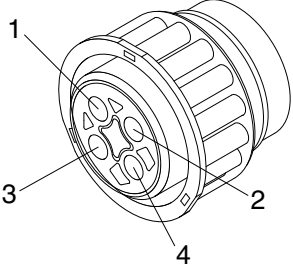
No. of pin	Receptacle connector (Female)	Plug connector (Male)
4	 <p style="text-align: right;">2-967325-3</p>	

23) DEUTSCH ENGINE ECM CONNECTOR

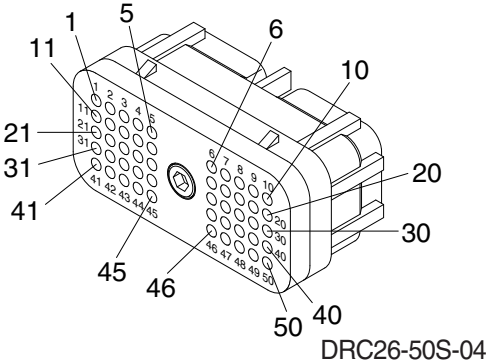
No. of pin	Receptacle connector (Female)	Plug connector (Male)
50	 <p style="text-align: right;">DRC26-50S-04</p>	

24) DEUTSCH INTERMEDIATE CONNECTOR

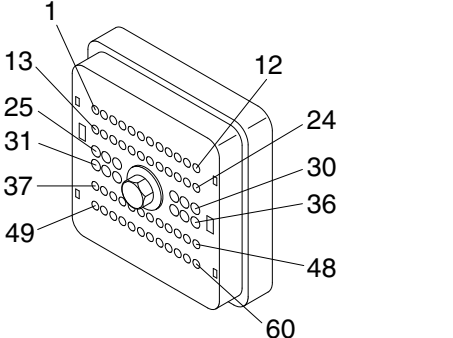
No. of pin	Receptacle connector (Female)	Plug connector (Male)
60	 <p style="text-align: right;">DRB16-60SAE-L018</p>	

25) TE MCU CONNECTOR

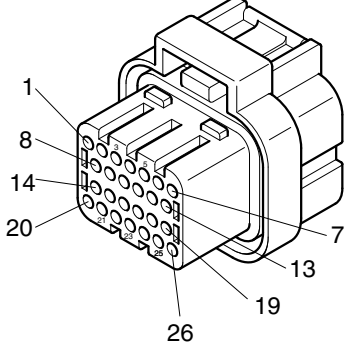
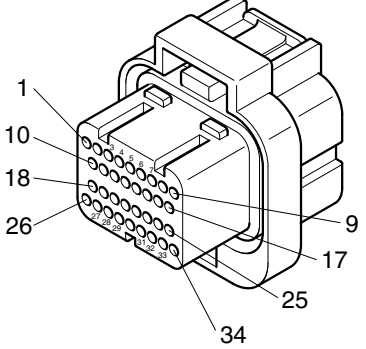
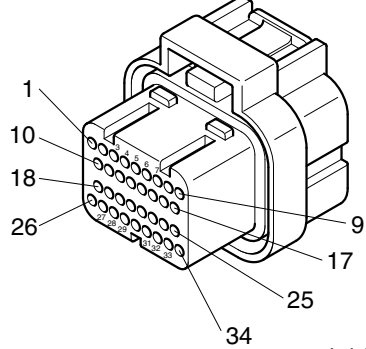
No. of pin	Receptacle connector (female)	Plug connector (male)
26	 <p style="text-align: right;">1473416-1</p>	
34	 <p style="text-align: right;">2-1437285-3 4-1437290-0</p>	
34	 <p style="text-align: right;">4-1437290-1</p>	