

SECTION 2 STRUCTURE AND FUNCTION

Group 1 Pump Device	2-1
Group 2 Main Control Valve	2-17
Group 3 Swing Device	2-51
Group 4 Travel Device	2-62
Group 5 RCV Lever	2-76
Group 6 RCV Pedal	2-83

SECTION 2 STRUCTURE AND FUNCTION

GROUP 1 PUMP DEVICE

1. STRUCTURE

The pump device consists of main pump, regulator and gear pump.

- WITHOUT PTO TYPE

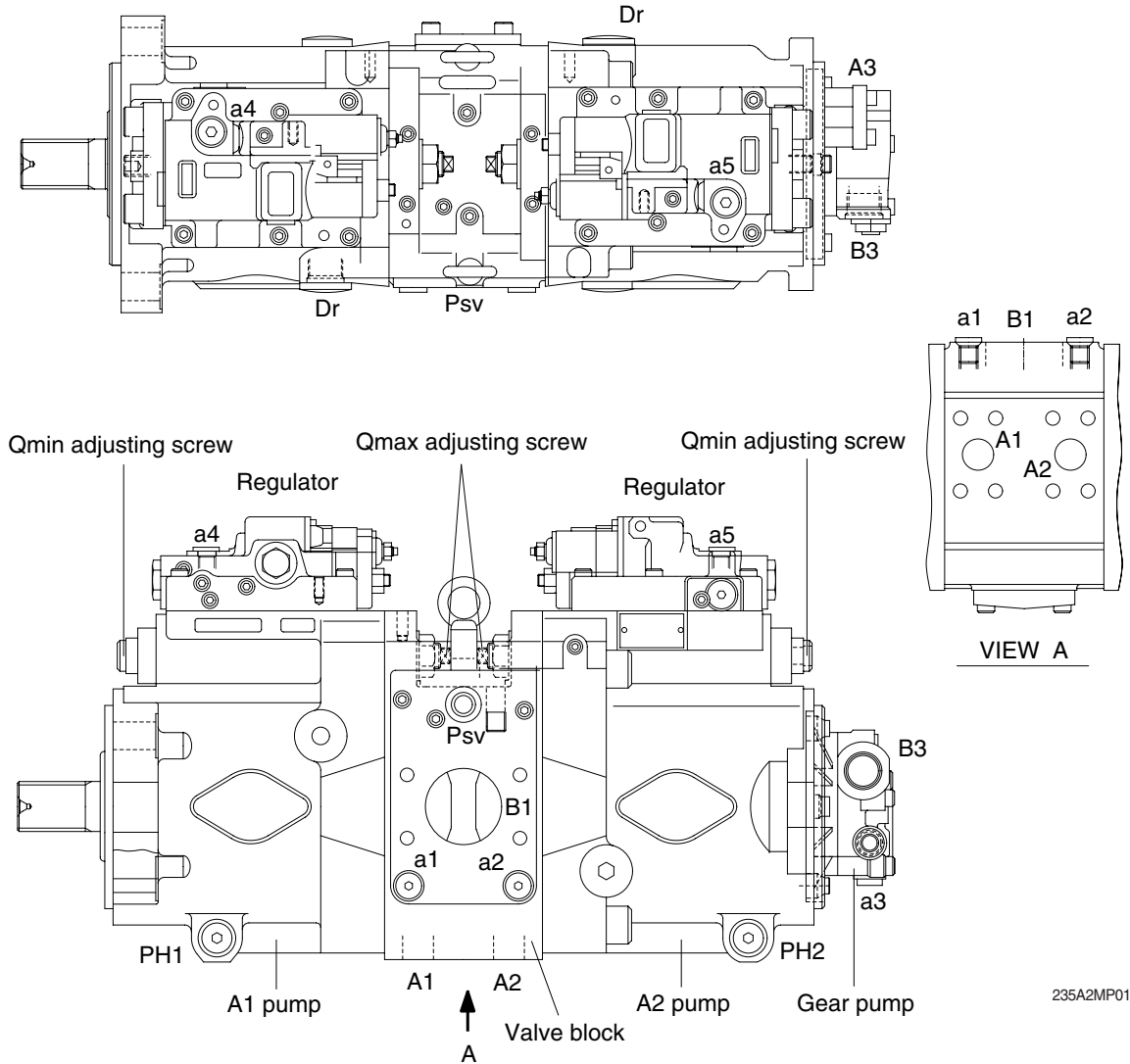

235A2MP01

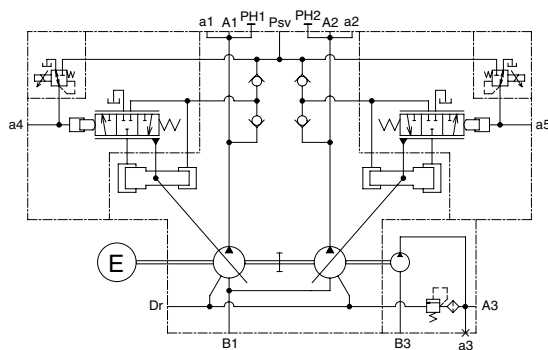

Port	Port name	Port size
A1,2	Delivery port	SAE6000psi 1"
B1	Suction port	SAE2500psi 2 1/2"
Dr	Drain port	PF 3/4 - 20
Psv	Servo assist port	PF 3/8 - 17
PH1,2	Pressure sensor port	PF 3/8-17
a1,2	Gauge port	PF 1/4 - 15
a3	Gauge port	PF 1/4-14
a4,5	Gauge port	PF 1/4 - 15
A3	Gear pump delivery port	PF 1/2 - 19
B3	Gear pump suction port	PF 3/4 - 20.5

· WITH PTO TYPE

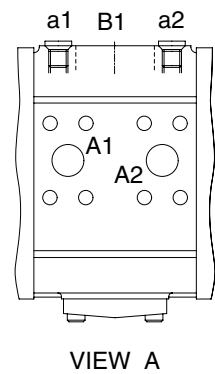
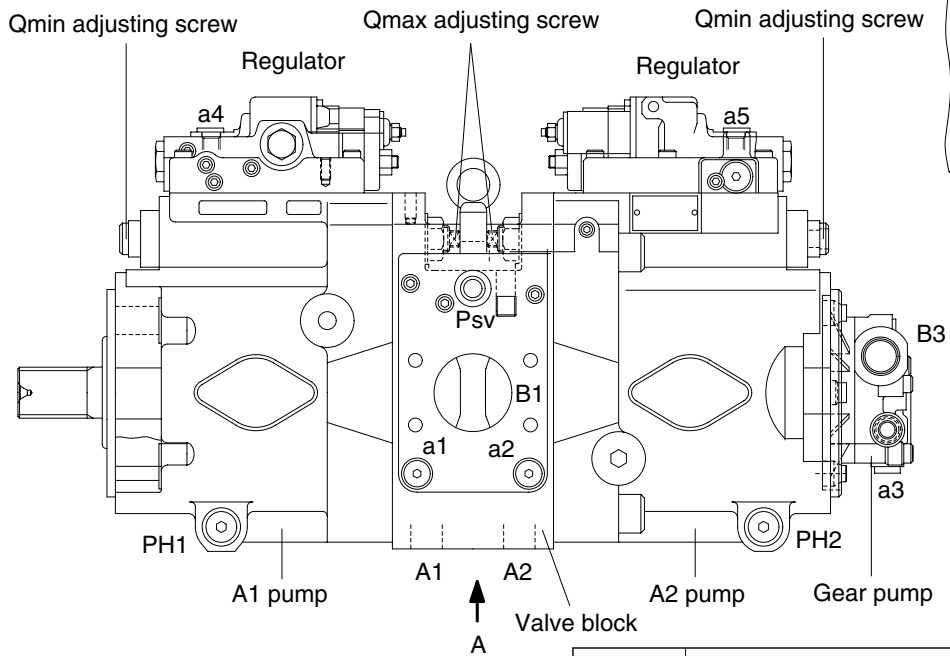
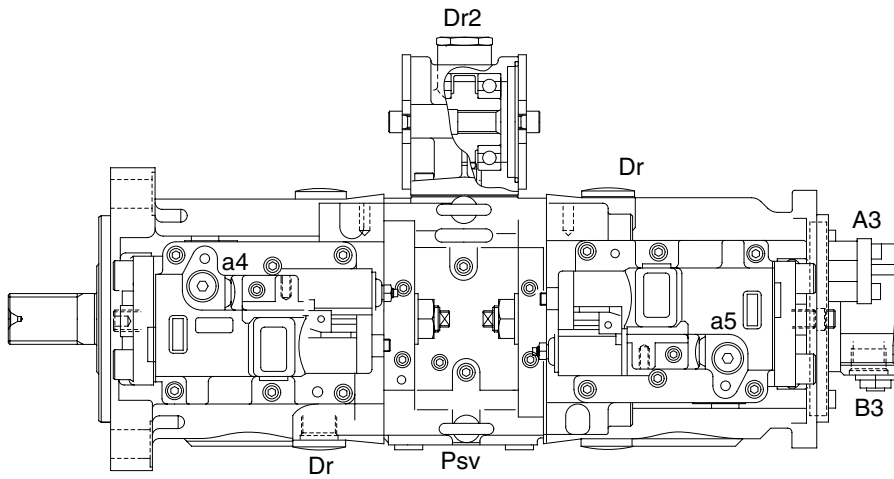

235A2MP02

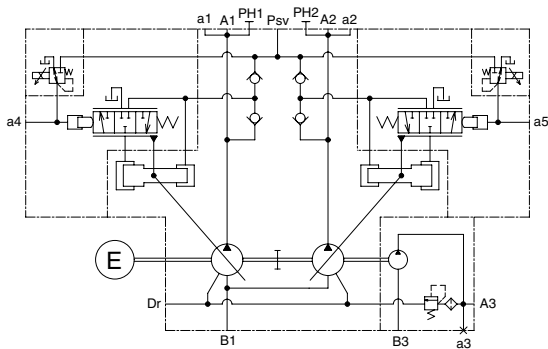

Port	Port name	Port size
A1,2	Delivery port	SAE6000psi 1"
B1	Suction port	SAE2500psi 2 1/2"
Dr,Dr2	Drain port	PF 3/4 - 20
Psv	Servo assist port	PF 3/8 - 17
PH1,2	Pressure sensor port	PF 3/8-17
a1,2	Gauge port	PF 1/4 - 15
a3	Gauge port	PF 1/4-14
a4,5	Gauge port	PF 1/4 - 15
A3	Gear pump delivery port	PF 1/2 - 19
B3	Gear pump suction port	PF 3/4 - 20.5

1) MAIN PUMP (1/3)

The main pump consists of two piston pumps (front & rear) and valve block.

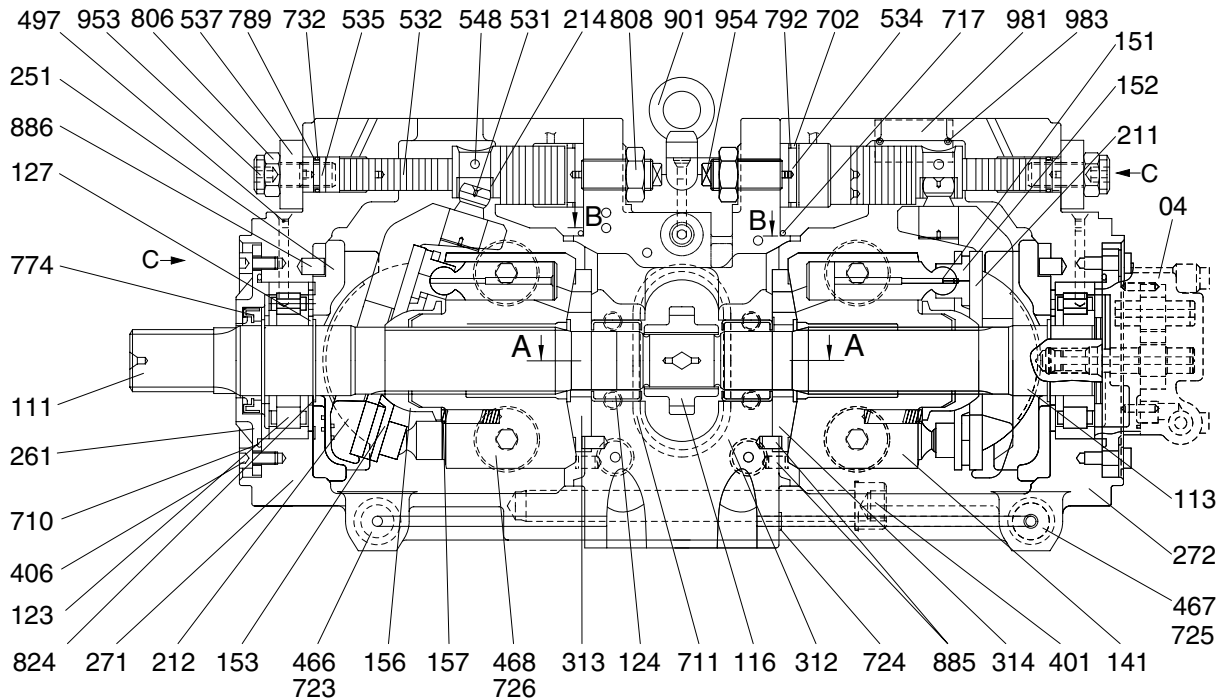

※ Section A-A, B-B, view C : see next page.

220F2MP05

04	Gear pump	272	Pump casing (R)	723	O-ring
111	Drive shaft (F)	312	Valve block B	724	Square ring
113	Drive shaft (R)	313	Valve plate (R)	725	O-ring
116	1st gear	314	Valve plate (L)	726	O-ring
123	Roller bearing	401	Hexagon socket bolt	732	O-ring
124	Needle bearing	406	Hexagon socket bolt	774	Oil seal
127	Bearing spacer	466	Plug	789	Back up ring
141	Cylinder block	467	Plug	792	Back up ring
151	Piston	468	Plug	806	Hexagon head nut
152	Shoe	497	Plug	808	Hexagon head nut
153	Set plate	531	Tilting pin	824	Snap ring
156	Spherical bushing	532	Servo piston	885	Pin
157	Cylinder spring	534	Stopper (L)	886	Pin
211	Shoe plate	535	Stopper (S)	901	Eye bolt
212	Swash plate	537	Servo cover	953	Set screw
214	Tilting bushing	548	Feedback pin	954	Set screw
251	Support	702	O-ring	981	Name plate
261	Seal cover (F)	710	O-ring	983	Pin
271	Pump casing (F)	711	O-ring		
		717	O-ring		

MAIN PUMP (2/3)

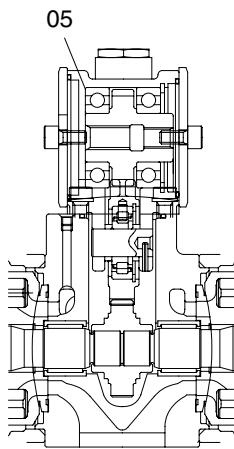

SECTION A-A
With PTO

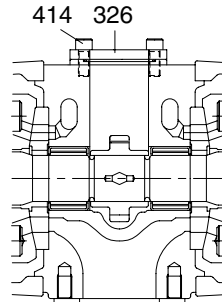

SECTION A-A
Without PTO

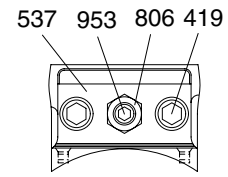

VIEW C

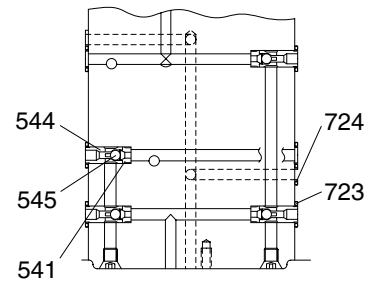

SECTION B-B

235A2MP06

05 PTO unit

326 Cover

414 Hexagon socket bolt

419 Hexagon socket bolt

537 Servo cover

541 Seat

544 Stopper 1

545 Steel ball

723 O-ring

724 Square ring

806 Hexagon head nut

953 Set screw

MAIN PUMP (3/3, WITH PTO TYPE)

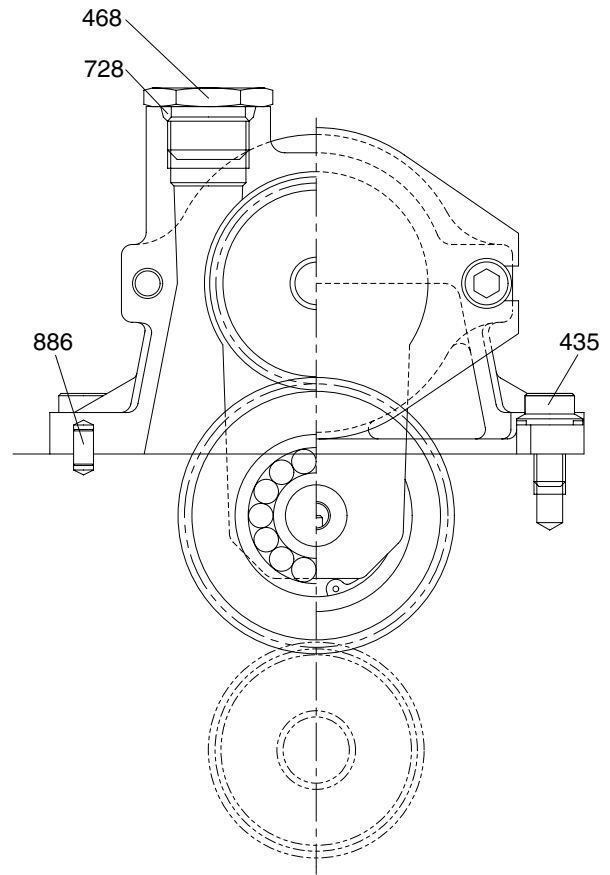
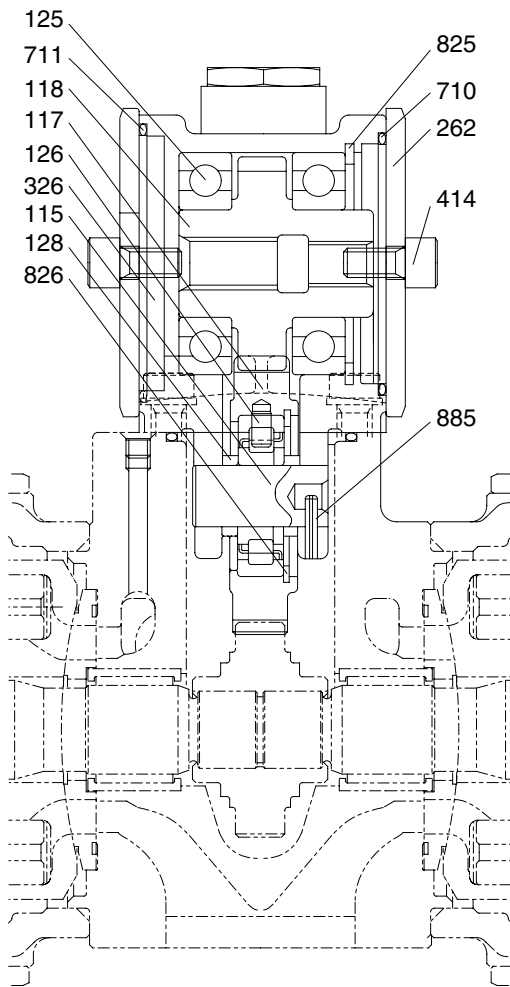

235A2MP07

115	Idler shaft	262	Cover	711	O-ring
117	Gear No. 2	326	Gear case	728	O-ring
118	Gear No. 3	414	Socket head screw	825	Retainer ring
125	Ball bearing	435	Flange head socket bolt	826	Retainer ring
126	Roller bearing	468	Plug	885	Spring pin
128	Bearing spacer	710	O-ring	886	Pin

2) REGULATOR (1/2)

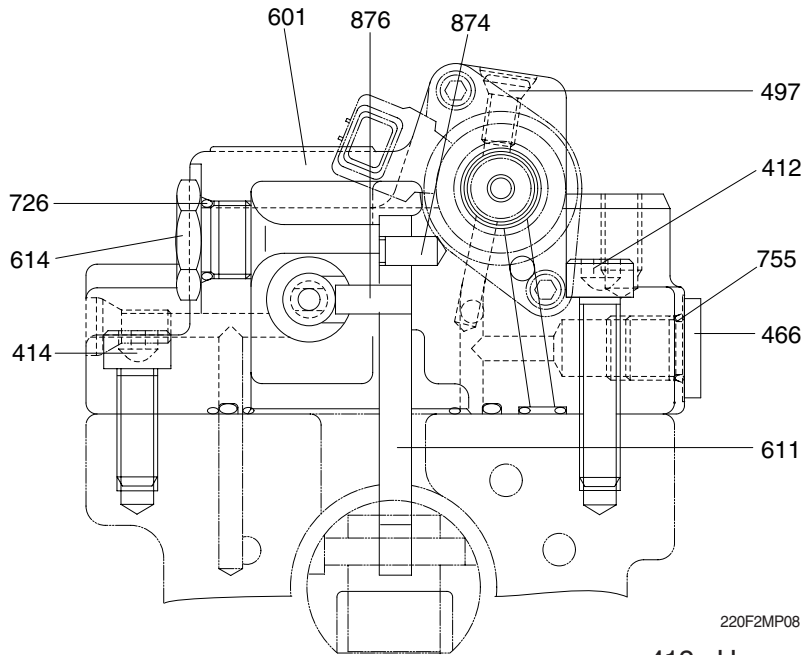

SECTION A-A

220F2MP08

- 412 Hexagon socket screw
- 414 Hexagon socket screw
- 466 Plug
- 497 Plug
- 601 Casing
- 611 Feed back lever
- 614 Adjust plug
- 726 O-ring
- 755 O-ring
- 874 Pivot pin
- 876 Pin

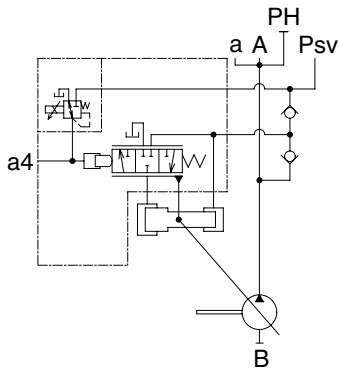

Port	Port name	Port size
A	Delivery port	SAE 6000 psi 1"
B	Suction port	SAE 2500 psi 2 1/2"
Psv	Servo assist port	PF 3/8-17
a, a4	Gauge port	PF 1/4-15
PH	Pressure sensor port	PF 3/8-17

REGULATOR (2/2)

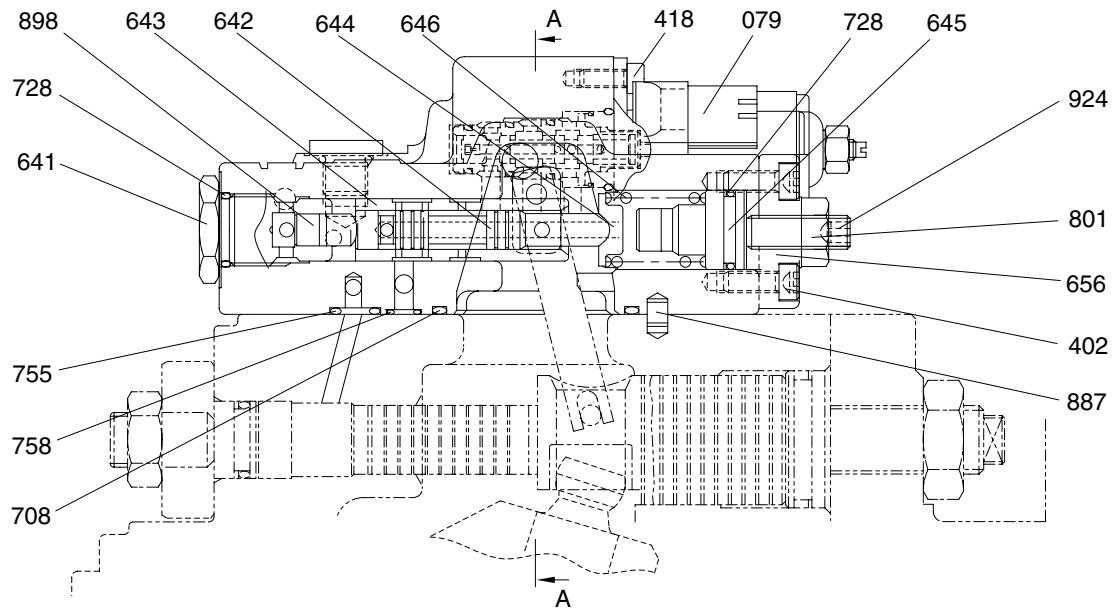

220F2MP09

079	Proportional ps reducing valve	644	Spring seat (Q)	755	O-ring
402	Hexagon socket screw	645	Adjust stem (Q)	758	Square ring
418	Hexagon socket screw	646	Pilot spring	801	Nut
641	Pilot plug	656	Cover	887	Pin
642	Pilot spool	708	O-ring	898	Piston piston
632	Pilot sleeve	728	O-ring	924	Set screw

3) GEAR PUMP

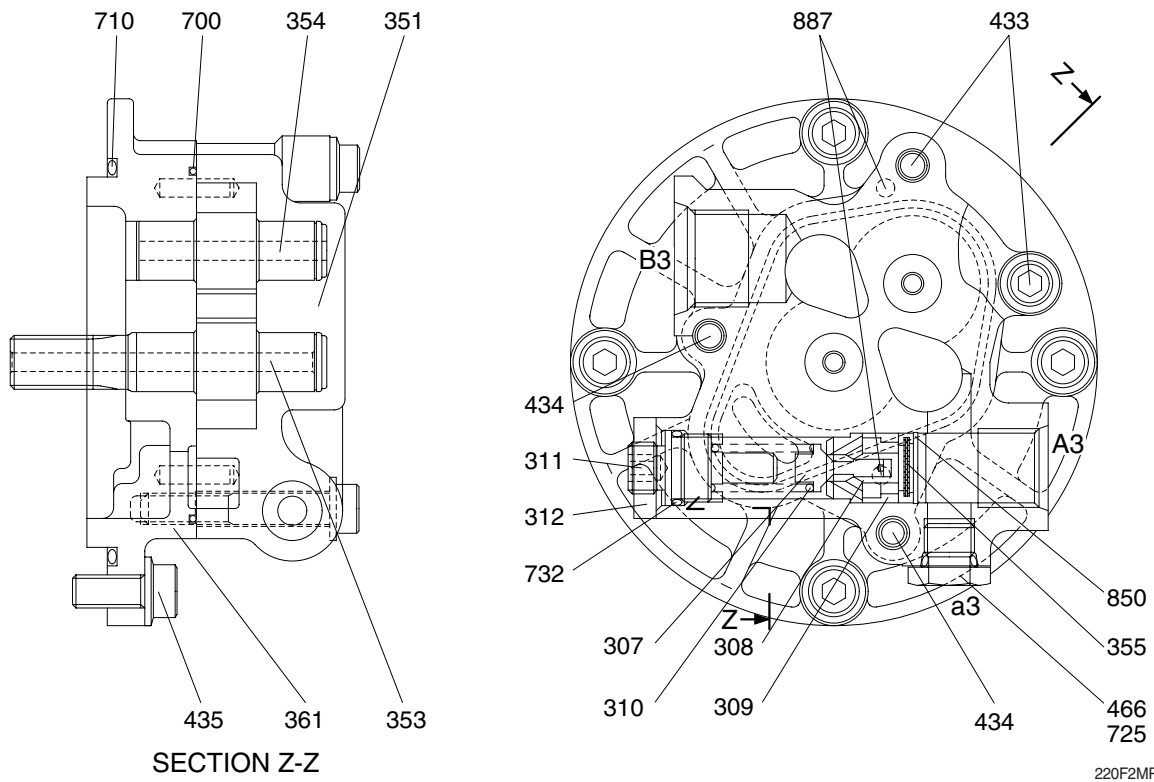

220F2MP10A

307	Poppet	353	Drive gear	466	Plug
308	Seat	354	Driven gear	700	Ring
309	Ring	355	Filter	710	O-ring
310	Spring	361	Front case	725	O-ring
311	Adjusting screw	433	Flange socket bolt	732	O-ring
312	Lock nut	434	Flange socket bolt	850	Snap ring
351	Gear case	435	Flange socket bolt	887	Pin

4) PROPORTIONAL REDUCING VALVE ASSY

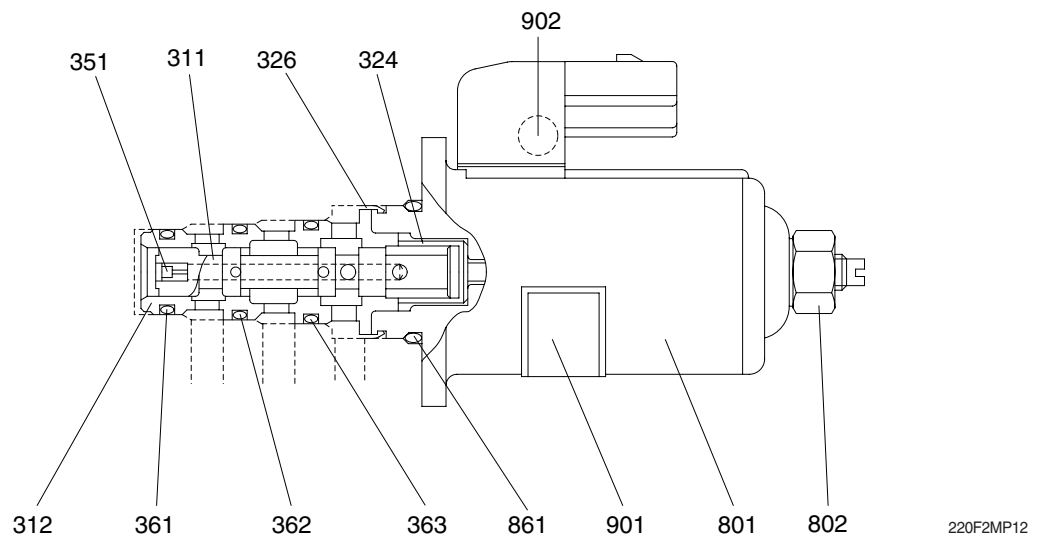

- | | | |
|--------------------|--------------|-------------------------|
| 311 Spool | 361 O-ring | 802 Seal nut |
| 312 Sleeve | 362 O-ring | 861 O-ring |
| 324 Spring | 363 O-ring | 901 Name plate |
| 326 Retaining ring | 801 Solenoid | 902 Function name plate |
| 351 Orifice | | |

2. MAIN PUMP

The pumps may be classified roughly into the rotary group performing a rotary motion and working as the major part of the whole pump function: the swash plate group that varies the delivery flow: and the valve block group that changes over oil suction and discharge: and the PTO group to attach an auxiliary gear pump.

1) ROTARY GROUP

The rotary group consists of drive shaft (F) (111), bearing spacers (127), cylinder block (141), piston shoes (151,152), set plates (153), spherical bushings (156) and cylinder springs (157). The drive shaft is supported by bearings (123,124) at its both ends.

The shoe is caulked to the piston to form a spherical joint for lessening thrust force generated by load pressure and has grooves to slide on the shoe plate (211) smoothly and hydraulically balanced. The piston-shoe sub group is pushed onto the shoe plate by the cylinder springs through the set plate and spherical bushing for enabling smooth sliding on the shoe plate. Similarly, the cylinder block is pushed onto the valve plate (313, 314) by the cylinder springs.

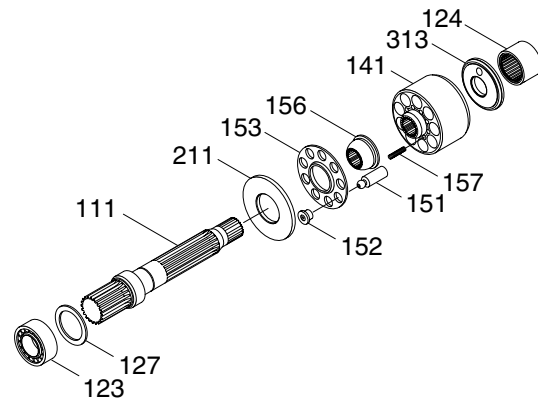

220S2MP13

2) SWASH PLATE GROUP

The swash plate group consists of swash plate (212), shoe plate (211), swash plate support (251), tilting bushing (214), tilting pin (531) and servo piston (532).

The swash plate is supported by the swash plate support at the cylindrical portion formed on the opposite side of the shoe sliding face.

When the servo piston is moved to the left or right by introducing the hydraulic force controlled by the regulator into the hydraulic chamber provided on both ends of the servo piston, the swash plate slides over the swash plate support through the spherical portion of the tilting pin and can vary the tilting angle (α).

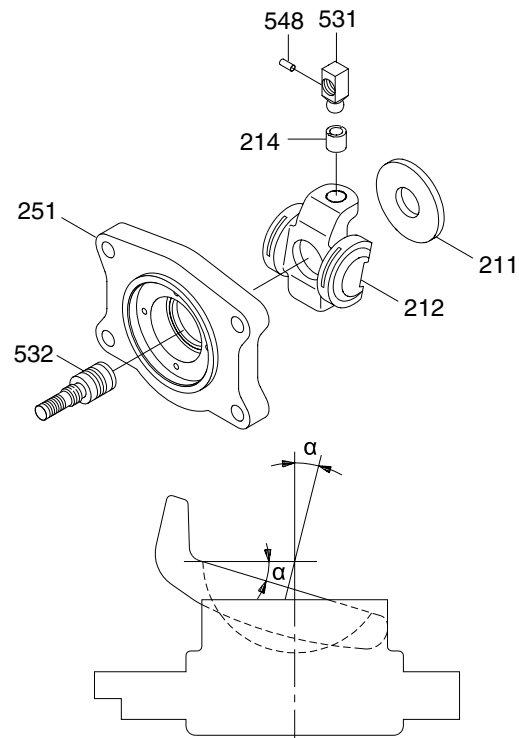

220S2MP14

3) VALVE BLOCK GROUP

The valve block group consists of the valve block (312), valve plate (313, 314) and valve plate pin (885).

The valve plate having two arc ports is attached to the valve block and feeds and collects oil to and from the cylinder block.

The oil exchanged by the valve plate is connected to an external piping through the valve block.

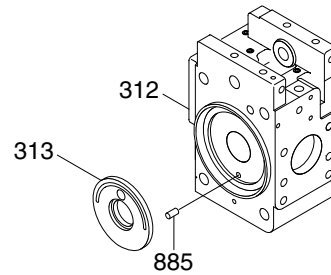

220S2MP15

4) PTO GROUP

The PTO group is composed of the 1st gear (116), 2nd gear (111) and 3rd gear (113).

The 2nd gear (111) and 3rd gear (113) are supported by the bearings, respectively and attached to the valve block.

Now, suppose the drive shaft is rotated by the motor or engine, the cylinder block is also rotated through the spline connection. If the swash plate is tilted, the pistons arranged inside the cylinder reciprocate relatively to the cylinder, rotating with the cylinder block. Accordingly, if a piston is focused on, its motion is separating from the valve plate (oil suction process) for 180 degrees, and approaching the valve plate (oil delivery process) for the remaining 180 degrees. When the swash plate has a tilting angle of zero, the piston makes no stroke and discharges no oil.

In the meantime, the rotation of the drive shaft is picked up by the 1st gear (116), transmitted to the 3rd gear (113) through the 2nd gear (111), and drives the auxiliary pump connected to the 3rd gear (113).

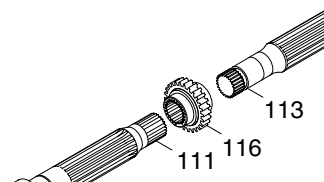

220F2MP11

3. REGULATOR

1) OUTLINE

The regulator for the K7V series axial piston pump has various models to satisfy various kinds of specifications required.

Electric flow control

By changing the pilot electric current I for proportional reducing valve, the pump tilting angle (delivery flow) is controlled arbitrarily, as shown in the figure.

This regulator has the positive flow control in which the delivery flow Q increases as the pilot electric current I increases. With this commanded, the pump discharges the required flow only, and so it does not consume the power uselessly.

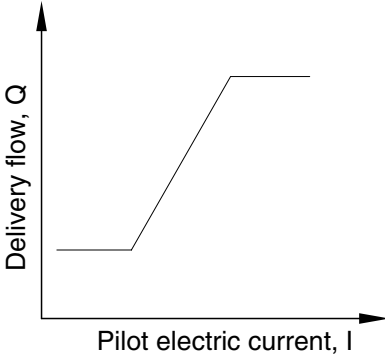

220F2MP16

2) FUNCTION

(1) Flow control

By changing the pilot electric current I , the pump tilting angle (delivery flow) is regulated arbitrarily, as shown in the figure.

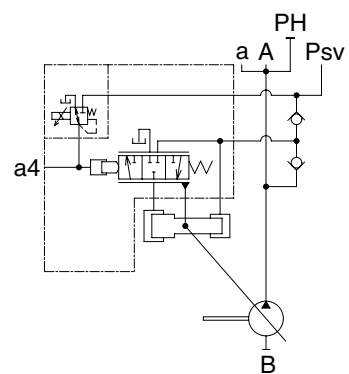
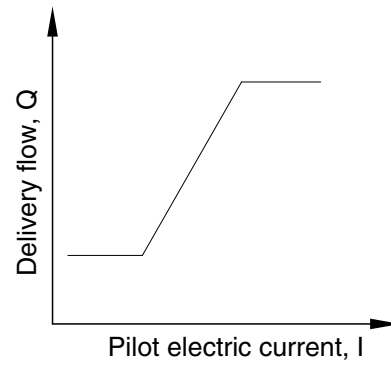

220F2MP17

① **Flow increasing function**

As the pilot electric current I increases, the secondary pressure of the proportional reducing valve (079) increases too. Then the pilot spool (642) through the pilot piston (898) moves to the right to position where the force of the pilot spring (646) balances with the hydraulic force.

The movement of the pilot spool (642) causes the port C1 connects to the tank port (T). This deprives the pressure of the large-diameter section of the servo piston (531) and moves the servo piston (532) to the right by the discharge pressure P_{d1} in the small-diameter section, resulting in the flow rate increase.

The feedback lever (611) links both the servo piston (532) and the pilot sleeve (643). When the servo piston (532) moves, the feedback lever (611) rotates around the pivot A, and the pilot sleeve (643) moves to the left. This causes the opening between the pilot sleeve (643) and the pilot spool (642) to close slowly, and the servo piston (532) comes to being stop completely when the port C1 closes completely.

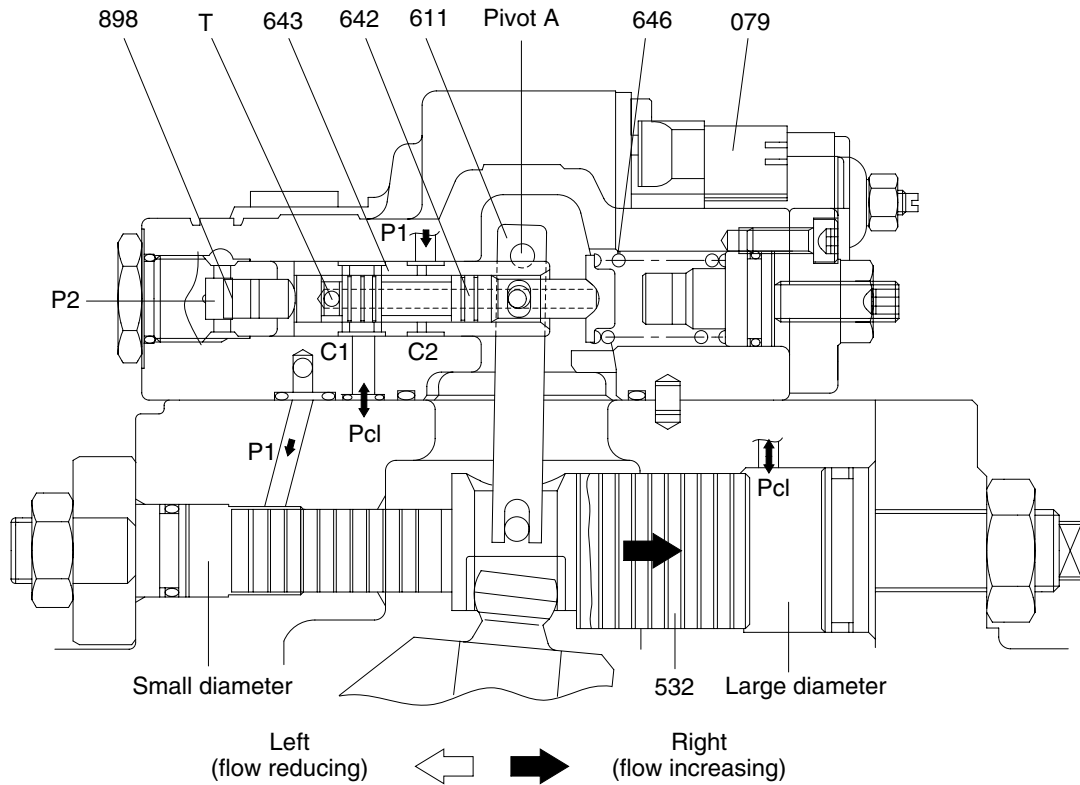

220F2MP25

② Flow reducing function

As the pilot electric current I decreases, the secondary pressure of the proportional reducing valve (079) decreases too, the pilot spool (642) moves to the left by action of the pilot spring (646).

The movement of the pilot spool (642) causes the delivery pressure $Pd1$ to connect to the port C2 through the pilot spool (642) and to be admitted to the large-diameter section of the servo piston (532). Although the delivery pressure $Pd1$ is constantly admitted to the small-diameter section of servo piston (532), the servo piston (532) moves to the left because of its difference of the area between large and small-diameter section. As a result, the tilting angle is decreased.

As the servo piston (532) moves, the feedback lever (611) rotates around the pivot A, and the pilot sleeve (643) moves to the right till the opening between the pilot spool (642) and pilot sleeve (643) being closed.

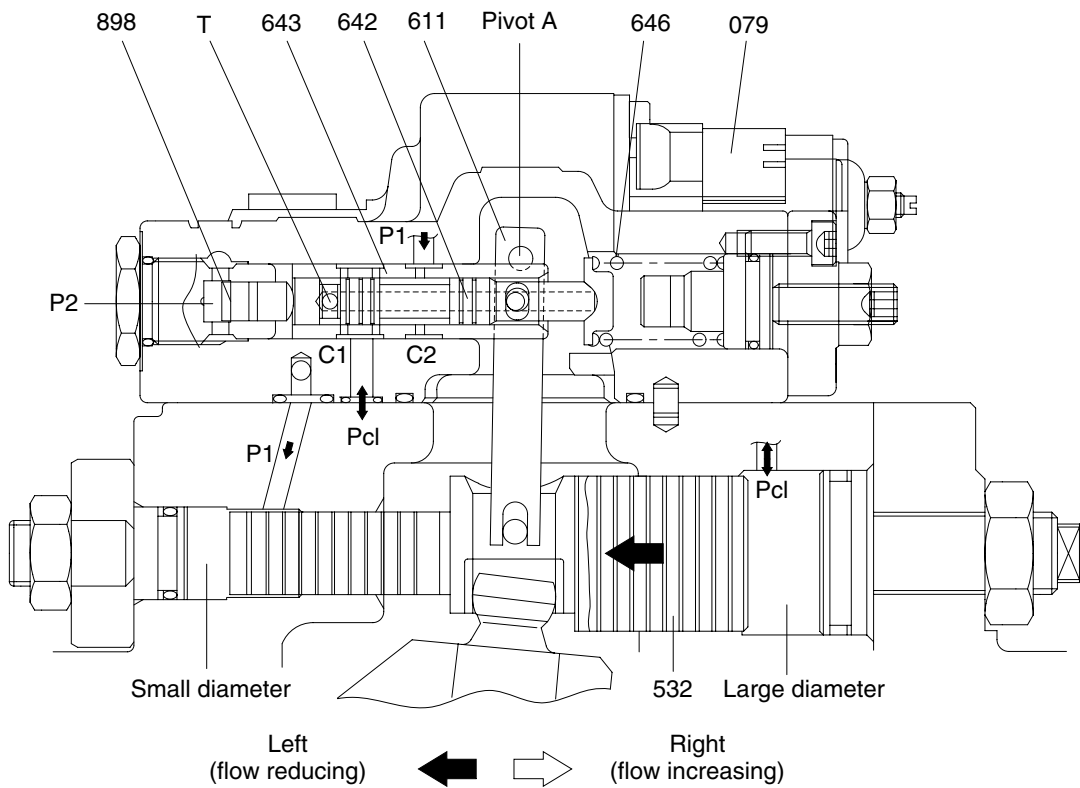

220F2MP26

4. ADJUSTMENT OF MAXIMUM AND MINIMUM FLOWS

The maximum flow and minimum flow can be adjusted with the adjusting screws (954, 953) of the pump. The flow control characteristics can be adjusted with the hexagon socket head cap (924). The horsepower control characteristics can be adjusted with the adjusting screw (C, 628) and adjusting stem (C, 627) of the regulator. The maximum flow and minimum flow can be adjusted with the adjusting screws of the pump.

1) ADJUSTMENT OF MAXIMUM FLOW (MAIN PUMP SIDE)

Adjust it by loosening the hexagon nut (808) and by tightening (or loosening) the hexagonal socket head screw (954). Only the maximum flow is adjusted without changing other control characteristics.

Speed	Adjustment of max flow	
	Tightening amount of adjusting screw (954)	Flow change amount
(min ⁻¹)	(Turn)	(ℓ/min)
1700	+1/4	-4.7

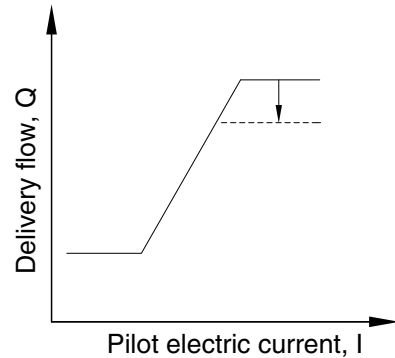
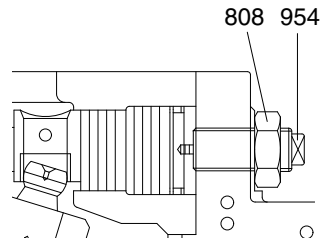

220F2MP18

2) ADJUSTMENT OF MINIMUM FLOW (MAIN PUMP SIDE)

Adjust it by loosening the hexagon nut (806) and by tightening (or loosening) the hexagon socket head set screw (953). Similarly to the adjustment of the maximum flow, other characteristics are not changed. However, remember that, if tightened too much, the required horsepower at the maximum delivery pressure (or during relieving) may increase.

Speed	Adjustment of min flow	
	Tightening amount of adjusting screw (953)	Flow change amount
(min ⁻¹)	(Turn)	(ℓ/min)
1700	+1/4	+3.3

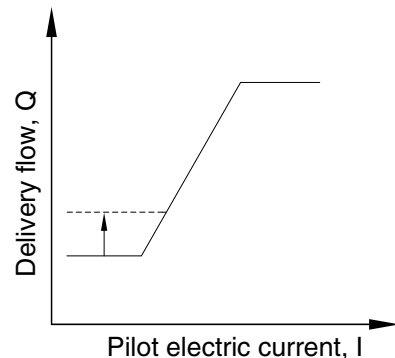
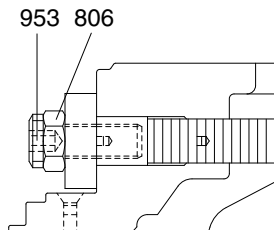

220F2MP19

3) ADJUSTMENT OF LOW CONTROL CHARACTERISTIC.

The flow control characteristic can be adjusted with the adjusting screw. Adjust it loosening the hexagon nut (801) and by tightening (or loosening) the hexagonal socket head screw (924). Tightening the screw shifts control chart to the right as shown in the figure.

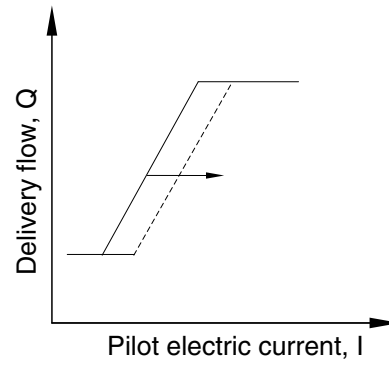

220AL2MP20

Speed	Flow control characteristics adjustment		
	Tightening amount of adjusting screw (953)	Current change in flow control initiation	Flow change amount
(min ⁻¹)	(Turn)	(mA)	(ℓ /min)
1700	+1/4	+26.8	-16.9

GROUP 2 MAIN CONTROL VALVE

1. STRUCTURE

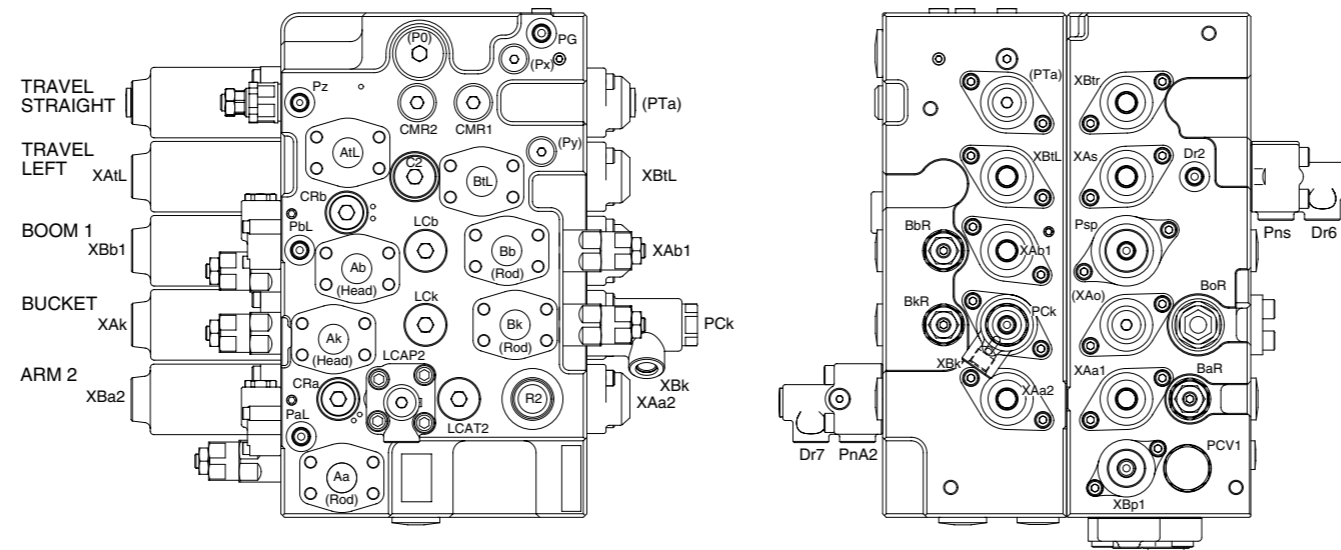
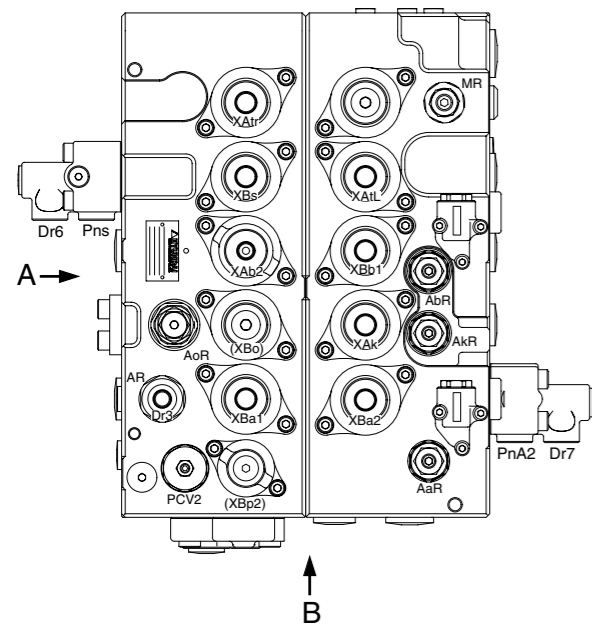
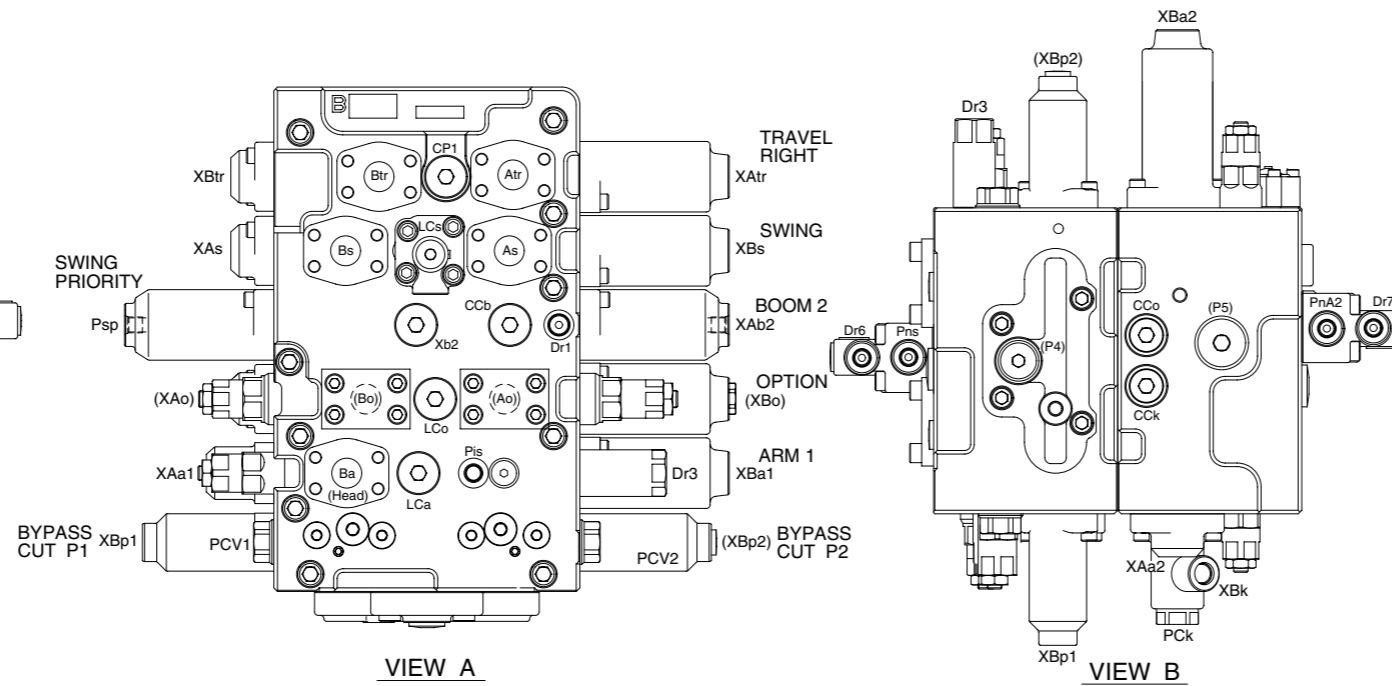
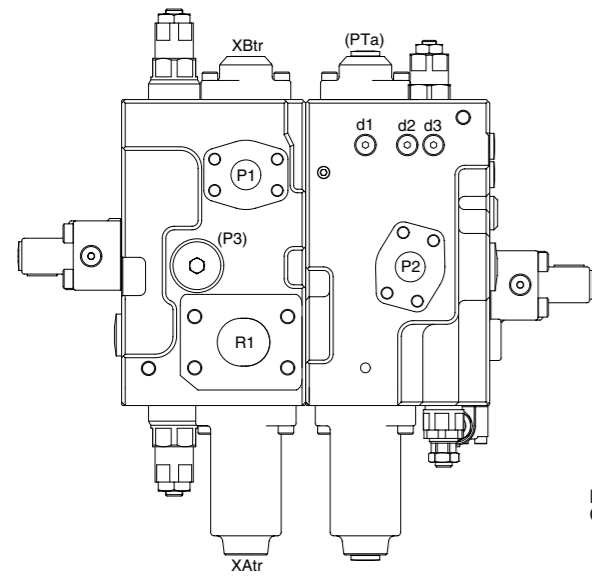

Mark	Port name	Port size	Tightening torque
R2	Make up port for swing	PF 1	20~25kgf · m (115~180lbf · ft)
XAttr XBtr (XAo) (XBo) XAk XBk XAb1 XBb1 XBa2 XAa2 XAa1 XBa1 Dr1 (PTa)	Travel right (reverse) pilot port Travel right (forward) pilot port Optional pilot port Optional pilot port Bucket in pilot port Bucket out pilot port Boom up pilot port Boom down pilot port Arm out confluence pilot port Arm in confluence pilot port Travel left (reverse) pilot port Travel left (forward) pilot port Swing left pilot port Swing right pilot port Arm out pilot port Arm in pilot port Drain port Travel straight pilot port	PF 3/8	7~8kgf · m (50.6~57.8lbf · ft)
(Px) (Py) Pz PG Dr2 Dr3 Dr6 Dr7 Pns PaL PbL XAb2 Psp XBp1 (XBp2) PCK Pis PnA2	Pressure port for attachment Pressure port for travel Main relief pilot pressure port Pilot pressure port Drain port Drain port Drain port Drain port Swing logic valve pilot port Lock valve pilot port (arm rod side) Lock valve pilot port (boom head side) Boom up confluence pilot port Swing priority pilot port Bypass cut spool pilot port (P1 side) Bypass cut spool pilot port (P2 side) Bucket in stroke limiter pilot port Arm regeneration cut pilot port Arm2 logic valve pilot port	PF 1/4	3.5~3.9kgf · m (25.3~28.2lbf · ft)
Atr Btr (Ao) (Bo) Ak Bk Ab Bb ATL BtL As Bs Aa Ba P1 P2	Travel motor right side (reverse) port Travel motor right side (forward) port Optional port Optional port Bucket cylinder head side port Bucket cylinder rod side port Boom cylinder head side port Boom cylinder rod side port Travel motor left side (reverse) port Travel motor left side (forward) port Swing motor left port Swing motor right port Arm cylinder rod side port Arm cylinder head side port Pump port (P1 side) Pump port (P2 side)	M10	5~6.6kgf · m (36.1~47.7lbf · ft)
R1	Return port	M12	8.5~11.2kgf · m (61.5~81.1lbf · ft)

1) RELIEF VALVE SIDE VIEW

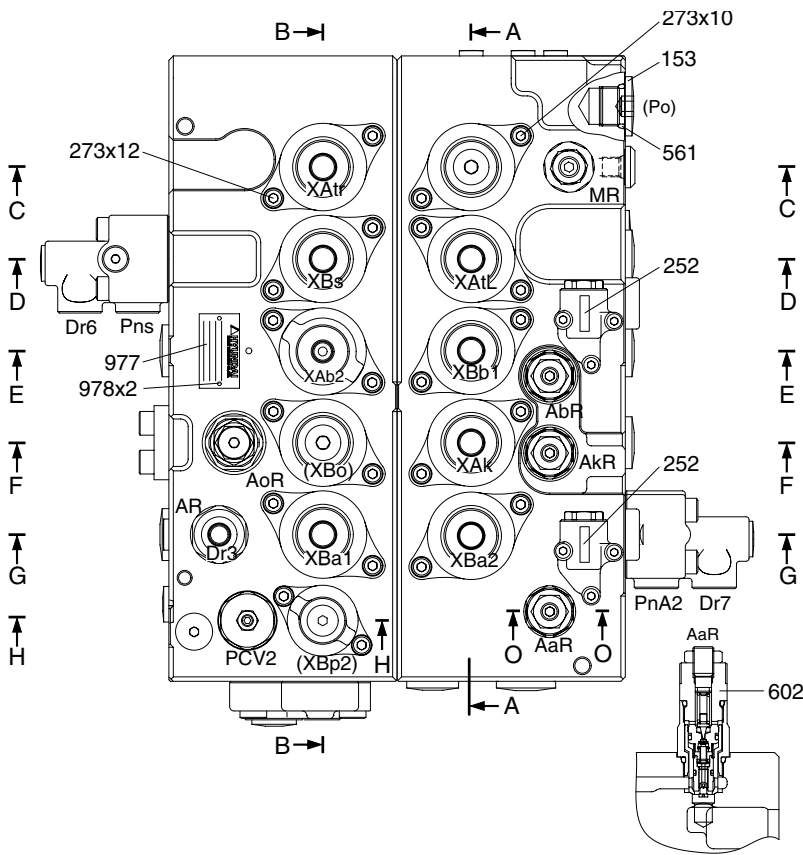

- 153 Plug
- 252 Lock valve selector sub assy
- 273 Socket screw
- 561 O-ring
- 602 Port relief valve assy
- 977 Name plate
- 978 Pin

SECTION O-O

235A2MC02

2) TANK PORT SIDE BOTTOM VIEW

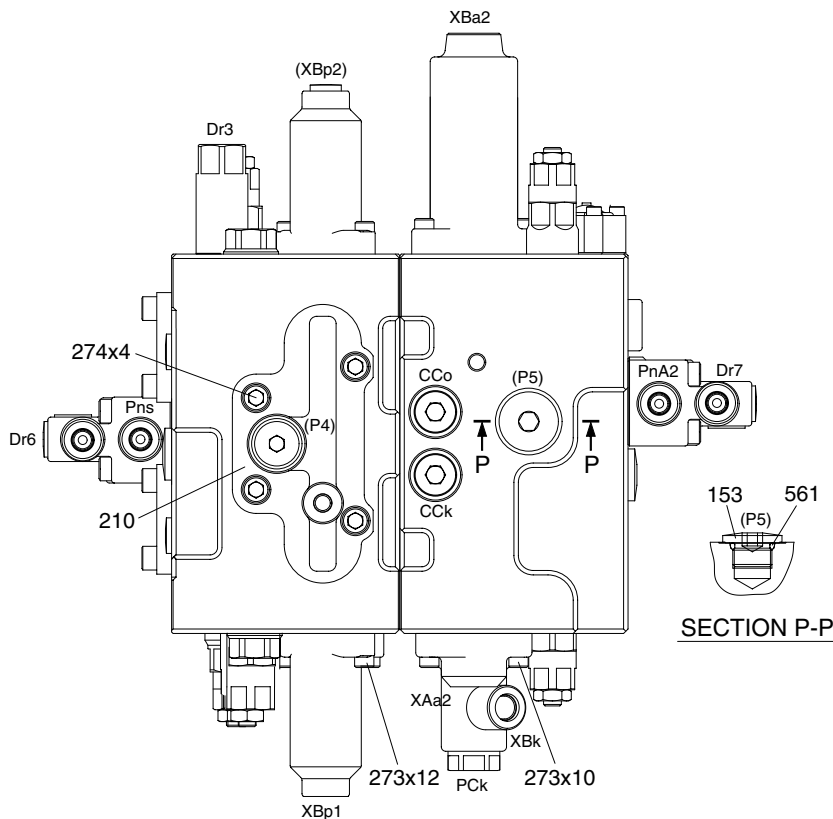

- 153 Plug
- 210 Plate
- 273 Socket screw
- 274 Socket screw
- 561 O-ring

SECTION P-P

220A2MC03

3) CASING A SPOOL SECTION

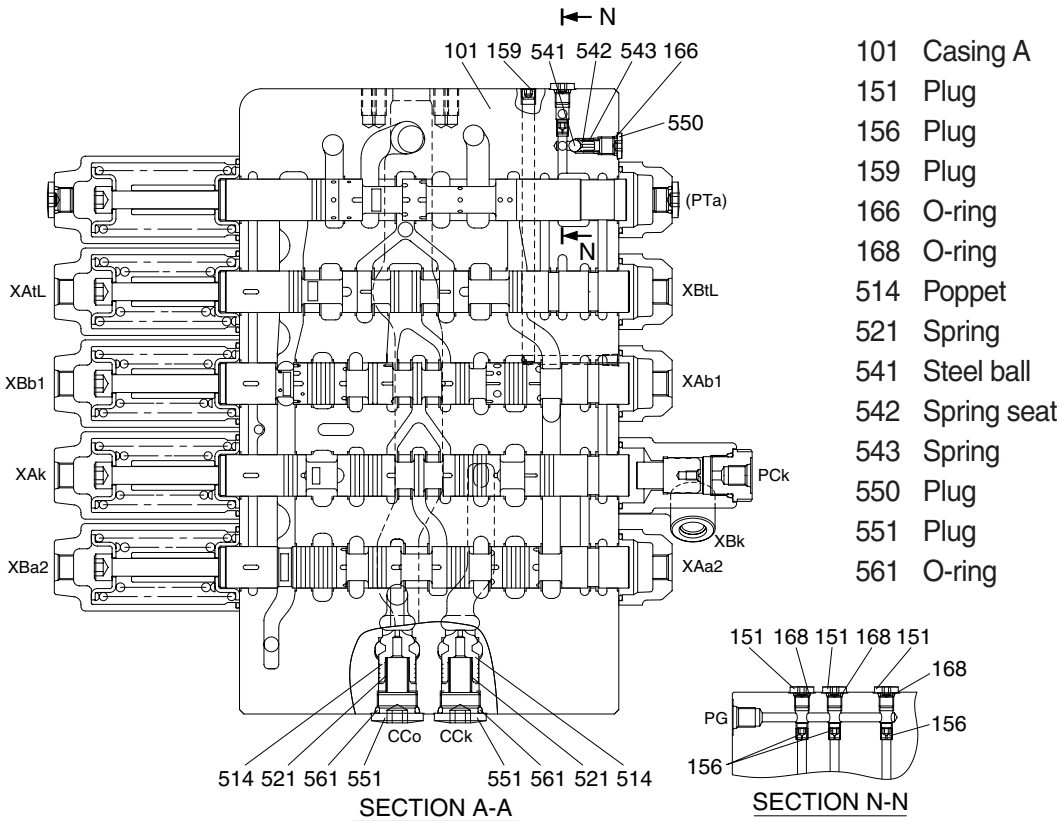

235A2MC04

4) CASING B SPOOL SECTION

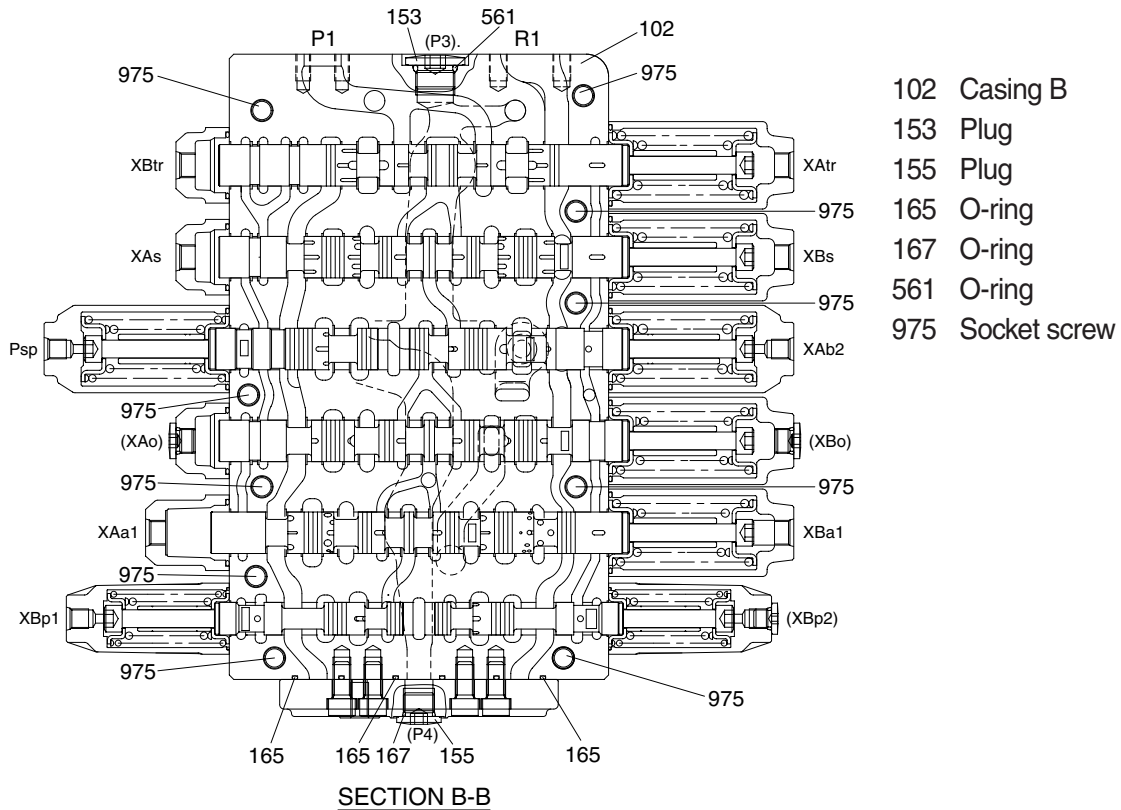

235A2MC05

5) TRAVEL RIGHT AND TRAVEL STRAIGHT SECTION

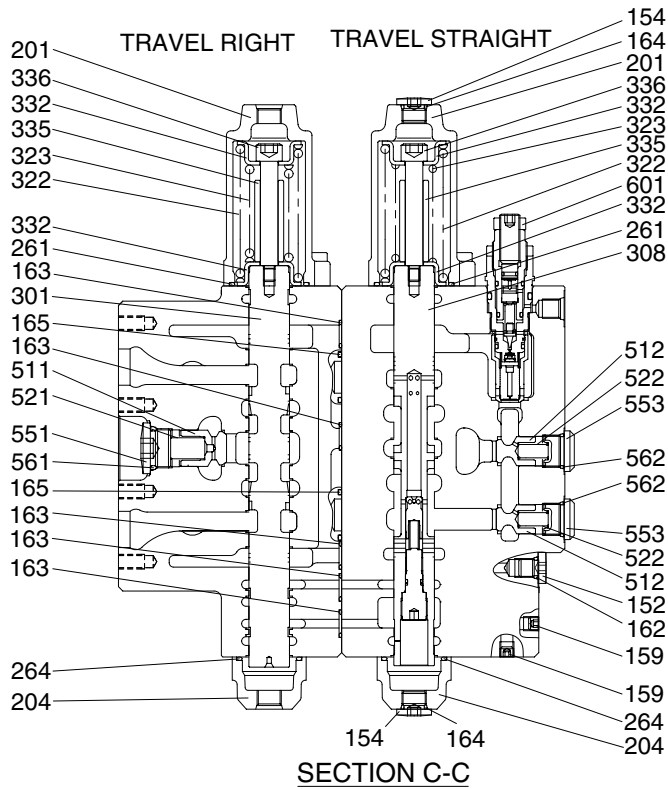

235A2MC06

- 152 Plug
- 154 Plug
- 159 Plug
- 162 O-ring
- 163 O-ring
- 164 O-ring
- 165 O-ring
- 201 Spring cover
- 204 Spool cover
- 261 O-ring
- 264 Square ring
- 301 Travel spool
- 308 Straight travel spool sub assy
- 322 Spring
- 323 Spring
- 332 Spring seat
- 335 Stopper
- 336 Spacer bolt
- 511 Poppet
- 512 Poppet
- 521 Spring
- 522 Spring
- 551 Plug
- 553 Plug
- 561 O-ring
- 562 O-ring
- 601 Main relief valve assy

6) SWING AND TRAVEL LEFT SECTION

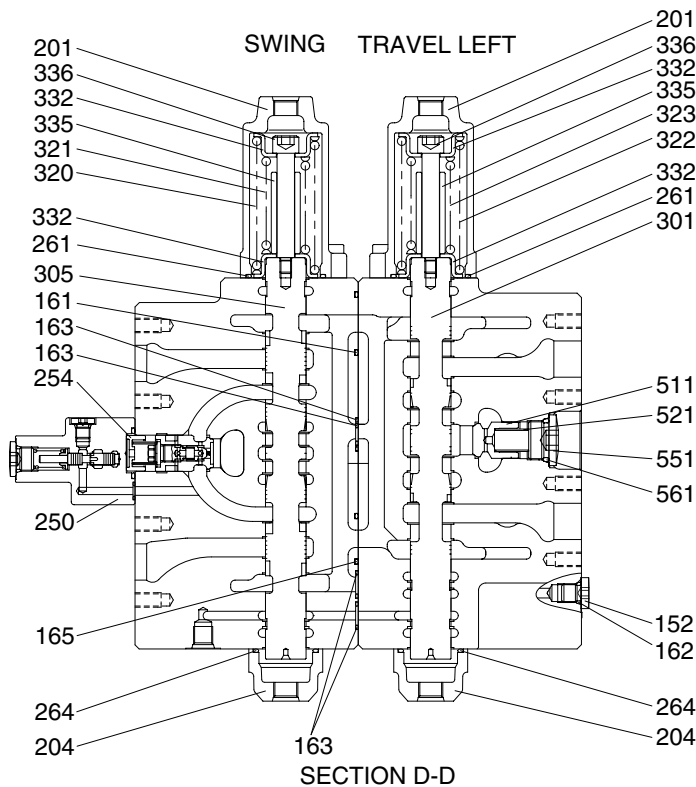

220F2MC07

- 152 Plug
- 161 O-ring
- 162 O-ring
- 163 O-ring
- 165 O-ring
- 201 Spring cover
- 204 Spool cover
- 250 Logic control valve assy
- 254 Swing Logic poppet assy
- 261 O-ring
- 264 Square ring
- 301 Travel spool
- 305 Swing spool
- 320 Spring
- 321 Spring
- 322 Spring
- 323 Spring
- 332 Spring seat
- 335 Stopper
- 336 Spacer bolt
- 511 Poppet
- 521 Spring
- 551 Plug
- 561 O-ring

7) BOOM 1 AND 2 SECTION

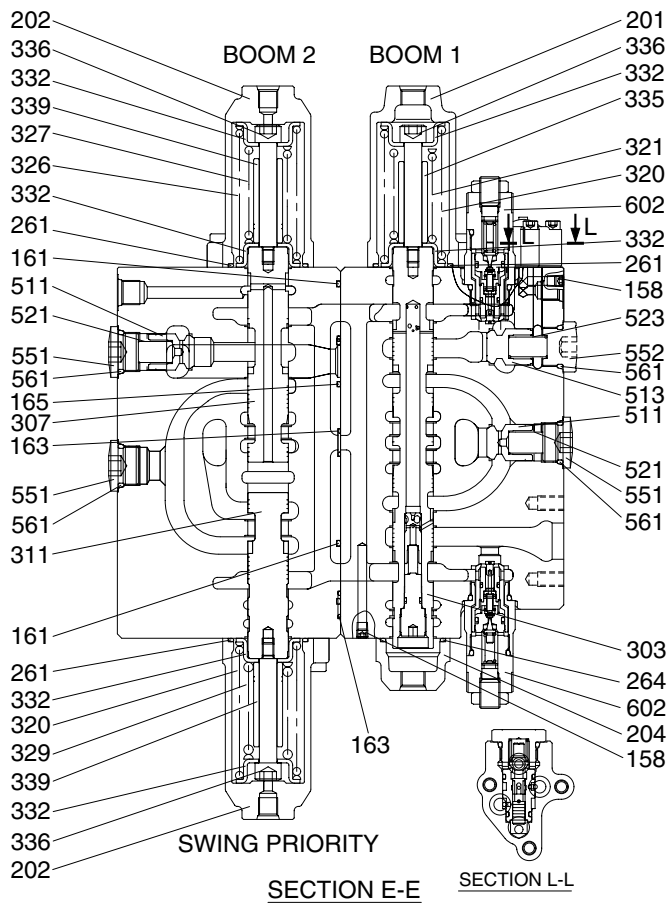

235A2MC08

- 158 Plug
- 161 O-ring
- 163 O-ring
- 165 O-ring
- 201 Spring cover
- 202 Spring cover
- 204 Spool cover
- 261 O-ring
- 264 Square ring
- 303 Boom 1 spool sub assy
- 307 Boom 2 spool
- 311 Swing priority spool
- 320 Spring
- 321 Spring
- 326 Spring
- 327 Spring
- 329 Spring
- 332 Spring seat
- 335 Stopper
- 336 Spacer bolt
- 339 Stopper
- 511 Poppet
- 513 Poppet
- 521 Spring
- 523 Spring
- 551 Plug
- 552 Plug
- 561 O-ring
- 602 Port relief valve assy

8) BUCKET AND OPTION SECTION

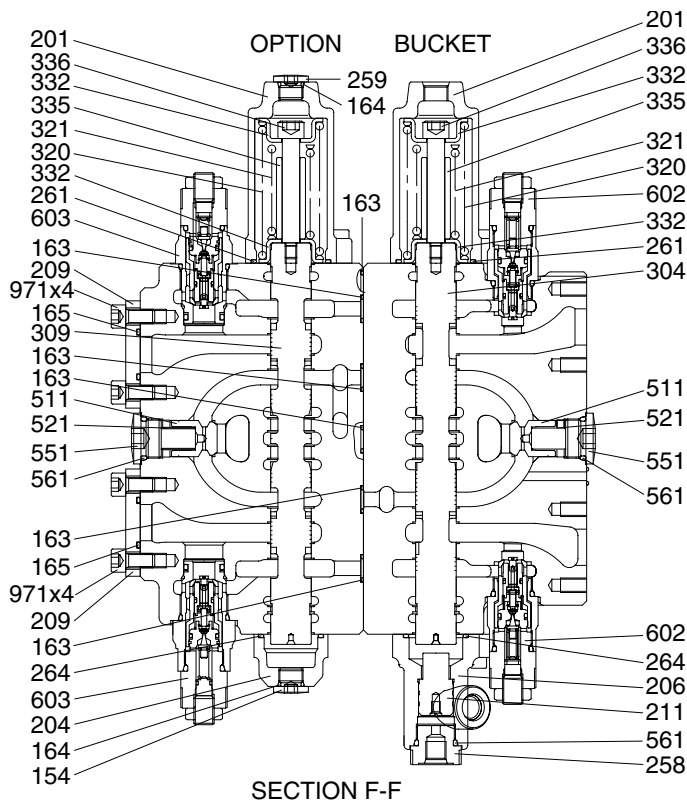

235A2MC09

- 154 Plug
- 163 O-ring
- 164 O-ring
- 165 O-ring
- 201 Spring cover
- 204 Spool cover
- 206 Spool cover
- 209 Flange
- 211 Piston
- 258 Plug
- 259 Plug
- 261 O-ring
- 264 Square ring
- 304 Bucket spool
- 309 Option spool
- 320 Spring
- 321 Spring
- 332 Spring seat
- 335 Stopper
- 336 Spacer bolt
- 511 Poppet
- 521 Spring
- 551 Plug
- 561 O-ring
- 602 Port relief valve assy
- 603 Port relief valve assy
- 971 Socket screw

9) ARM 1 AND 2 SECTION

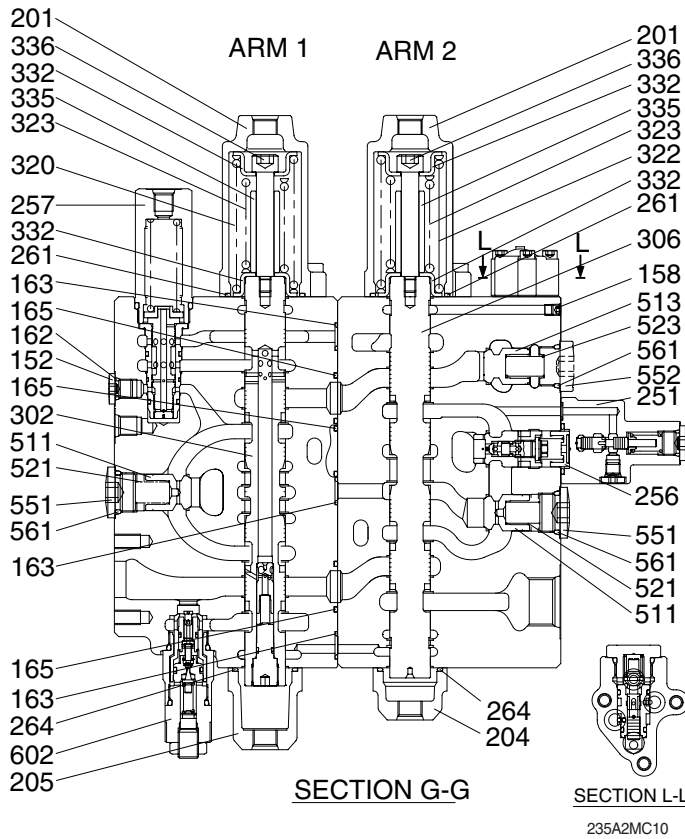

- 152 Plug
- 158 Plug
- 162 O-ring
- 163 O-ring
- 165 O-ring
- 201 Spring cover
- 204 Spool cover
- 205 Spool cover
- 251 Logic control valve assy
- 256 Arm 2 Logic poppet assy
- 257 Arm regeneration cut sub assy
- 261 O-ring
- 264 Square ring
- 302 Arm 1 spool sub assy
- 306 Arm 2 spool
- 320 Spring
- 322 Spring
- 323 Spring
- 332 Spring seat
- 335 Stopper
- 336 Spacer bolt
- 511 Poppet
- 513 Poppet
- 521 Spring
- 523 Spring
- 551 Plug
- 552 Plug
- 561 O-ring
- 602 Port relief valve assy

10) BYPASS CUT SECTION

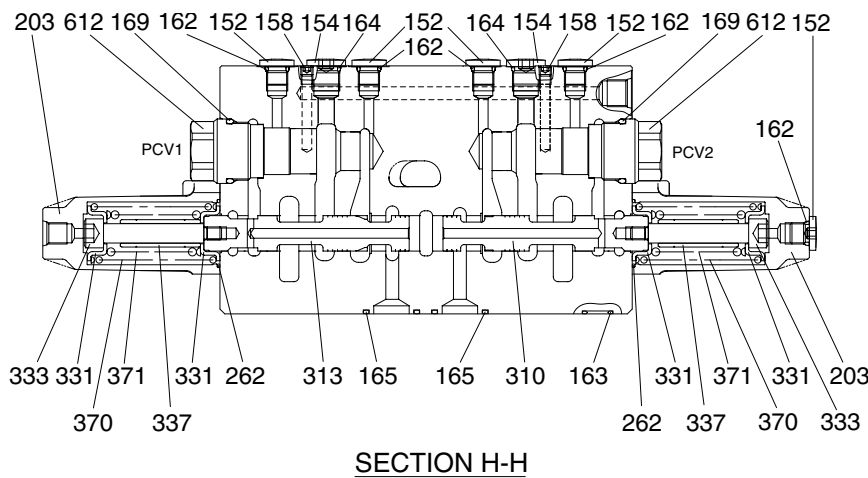

- 152 Plug
- 154 Plug
- 158 Plug
- 162 O-ring
- 163 O-ring
- 164 O-ring
- 165 O-ring
- 169 O-ring
- 203 Spring cover
- 262 O-ring
- 310 Bypass cut spool
- 313 Bypass cut spool
- 331 Spring seat
- 333 Spring seat
- 337 Stopper
- 370 Spring
- 371 Spring
- 612 Plug

11) MAIN RELIEF VALVE (601)

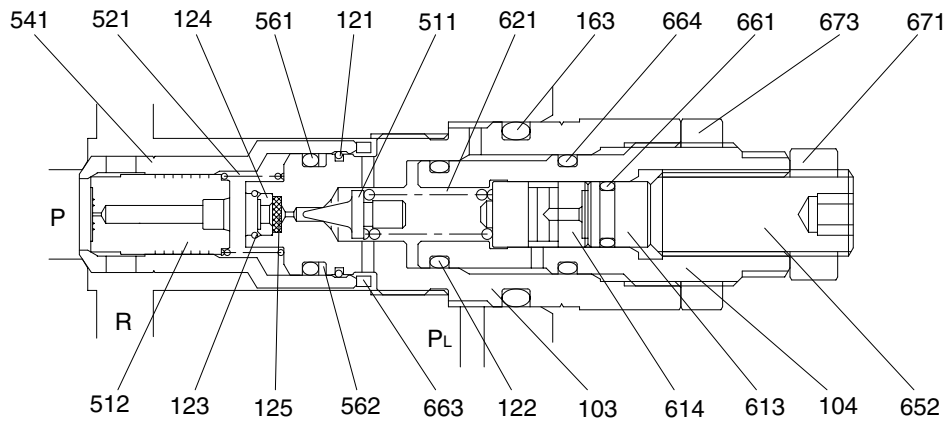

220F2MC70

103 Plug	512 Plunger	621 Spring
104 Adjust plug	521 Spring	652 Adjust screw
121 C-ring	541 Seat	661 O-ring
122 Spacer	561 O-ring	663 O-ring
124 Filler stopper	562 Back-up ring	664 O-ring
125 Filler	611 Poppet	671 Lock nut
163 O-ring	613 Stopper	673 Lock nut
	614 Piston	

12) PORT RELIEF VALVE (602)

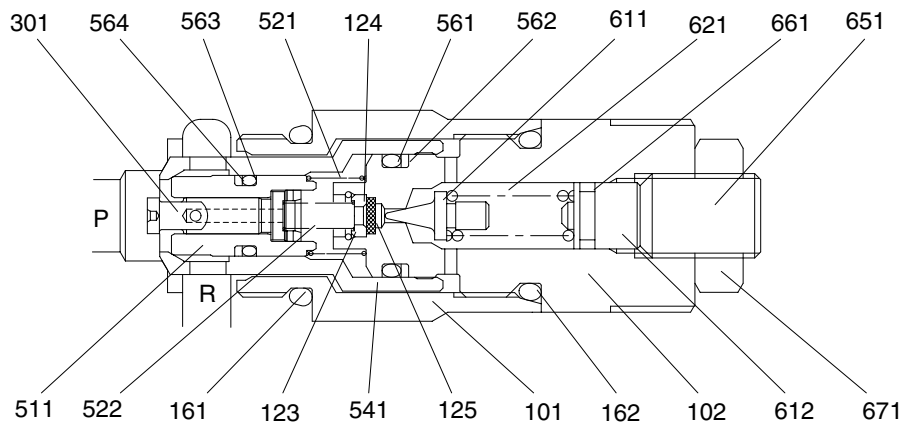

220F2MC71

101 Body	511 Plunger	564 Back-up ring
102 Plug	521 Spring	611 Poppet
161 O-ring	522 Spring	612 Spring seat
162 O-ring	541 Seat	621 Spring
123 O-ring	561 O-ring	651 Adjust screw
124 Filler stopper	562 Back-up ring	661 O-ring
125 Filler	563 O-ring	671 Lock nut

13) PORT RELIEF VALVE (603)

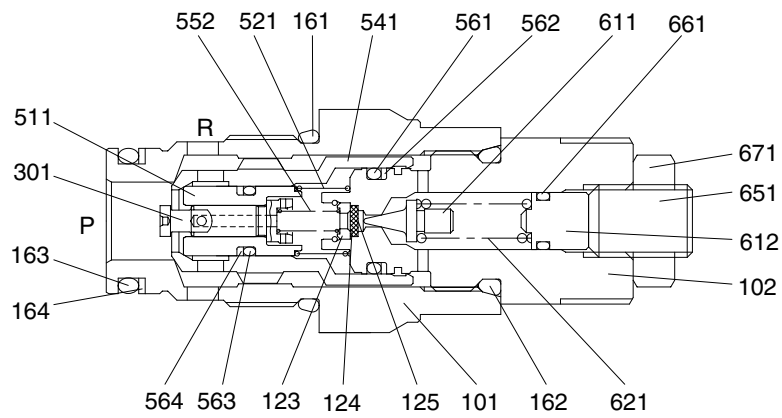

220F2MC72

- | | | |
|--------------------|------------------|------------------|
| 101 Body | 301 Piston | 564 Back-up ring |
| 102 Plug | 511 Plunger | 611 Poppet |
| 123 C-ring | 521 Spring | 612 Spring seat |
| 124 Filler stopper | 522 Spring | 621 Spring |
| 125 Filler | 541 Seat | 651 Adjust screw |
| 161 O-ring | 561 O-ring | 661 O-ring |
| 162 O-ring | 562 Back-up ring | 671 Lock nut |
| 163 O-ring | 563 O-ring | |

14) ARM 1 SPOOL ASSY (302)

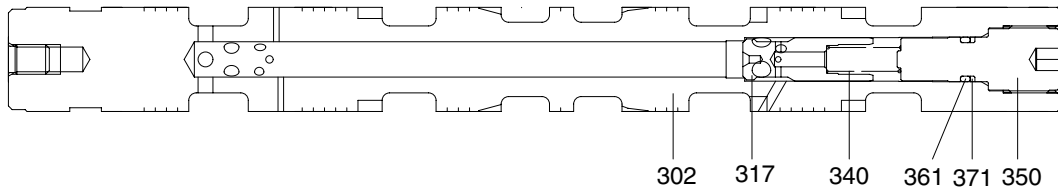

220F2MC73

302 Spool
317 Plunger

340 Spring
350 Plug

361 O-ring
371 Back-up ring

15) BOOM 1 SPOOL ASSY (303)

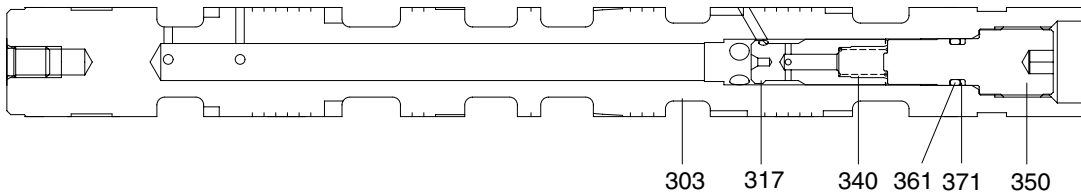

220F2MC74

303 Spool
317 Plunger

340 Spring
350 Plug

361 O-ring
371 Back-up ring

16) TRAVEL STRAIGHT SPOOL (308)

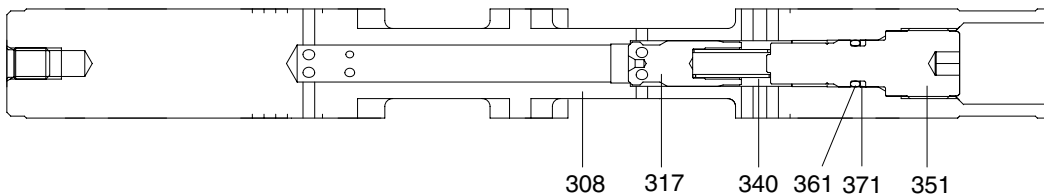

220F2MC75

308 Spool
317 Plunger

340 Spring
351 Plug

361 O-ring
371 Back-up ring

17) LOCK VALVE SELECTOR SUB ASSY (252)

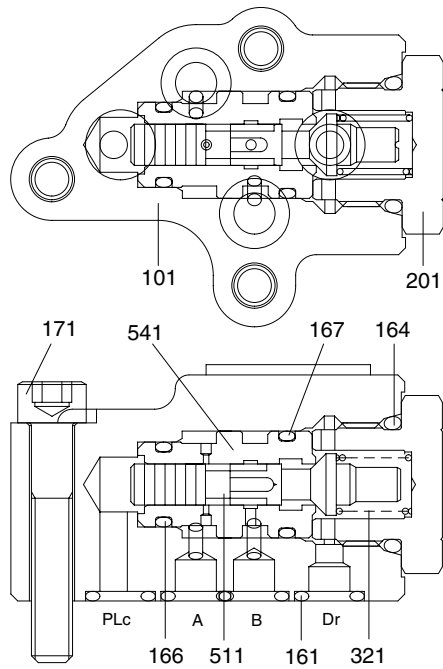

- 101 Casing
- 161 O-ring
- 164 O-ring
- 166 O-ring
- 167 O-ring
- 171 Hex socket head cap screw
- 201 Plug
- 321 Spring
- 511 Spool
- 541 Sleeve

220F2MC76

18) LOGIC CONTROL VALVE ASSY (250, 251)

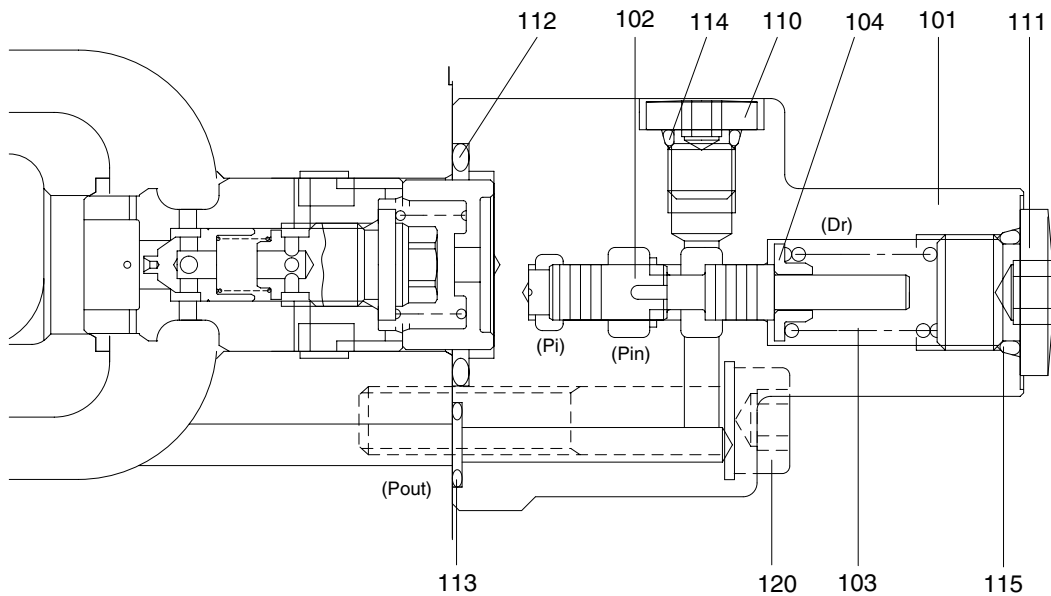

220F2MC77

- | | | |
|-----------------|------------|-------------------------------|
| 101 Casing | 110 Plug | 114 O-ring |
| 102 Spool | 111 Plug | 115 O-ring |
| 103 Spring | 112 O-ring | 120 Hex socket head cap screw |
| 104 Spring seat | 113 O-ring | |

19) SWING LOGIC POPPET ASSY (254)

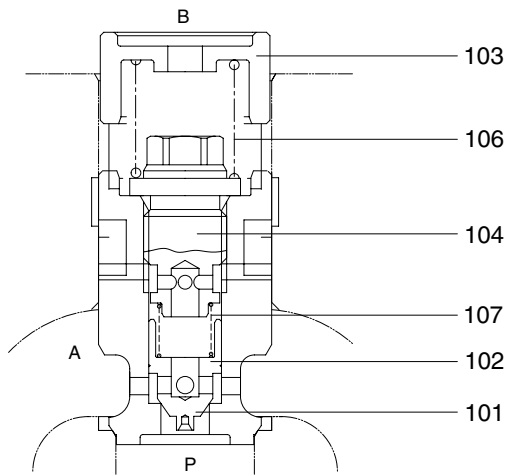

- 101 Logic poppet
- 102 Poppet
- 103 Spring seat
- 104 Plug
- 106 Spring
- 107 Spring

220F2MC78

20) ARM 2 LOGIC POPPET ASSY (256)

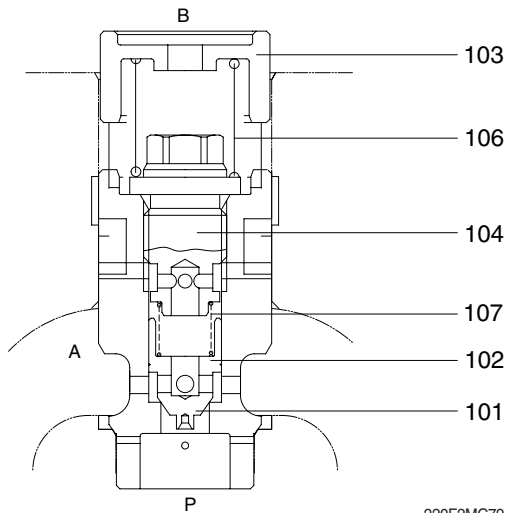

- 101 Logic poppet
- 102 Poppet
- 103 Spring seat
- 104 Plug
- 106 Spring
- 107 Spring

220F2MC79

21) ARM REGENERATION CUT SUB ASSY (257)

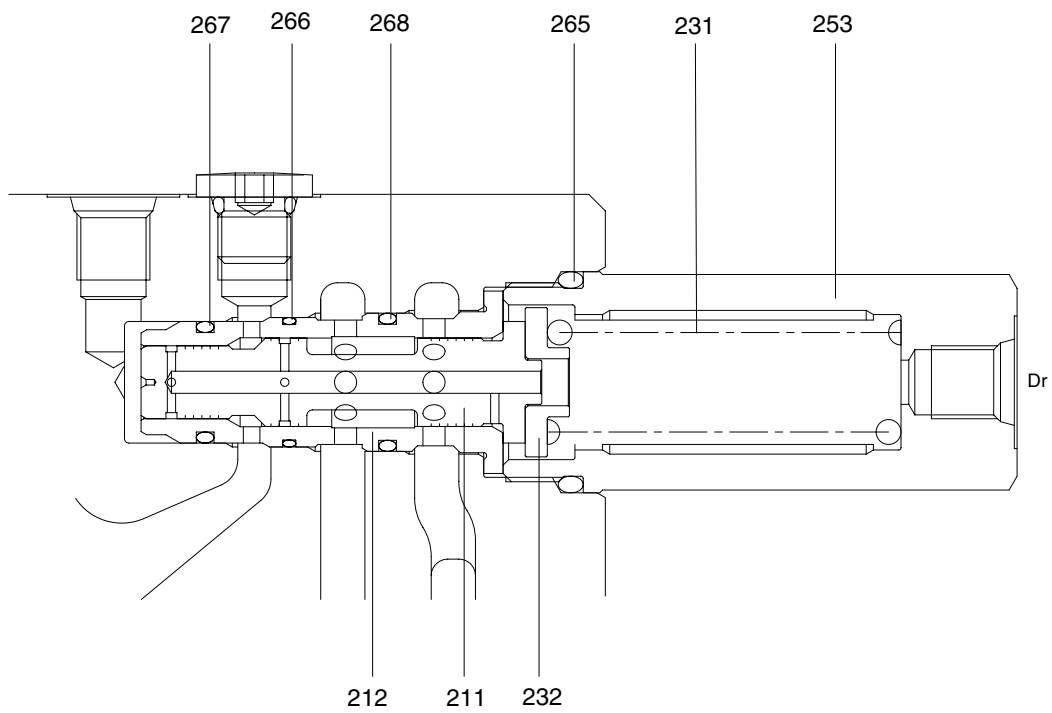

220F2MC80

- | | | |
|------------|-----------------|------------|
| 211 Spool | 232 Spring seat | 266 O-ring |
| 212 Sleeve | 253 Plug | 267 O-ring |
| 231 Spring | 265 O-ring | 268 O-ring |

2. HYDRAULIC CIRCUIT

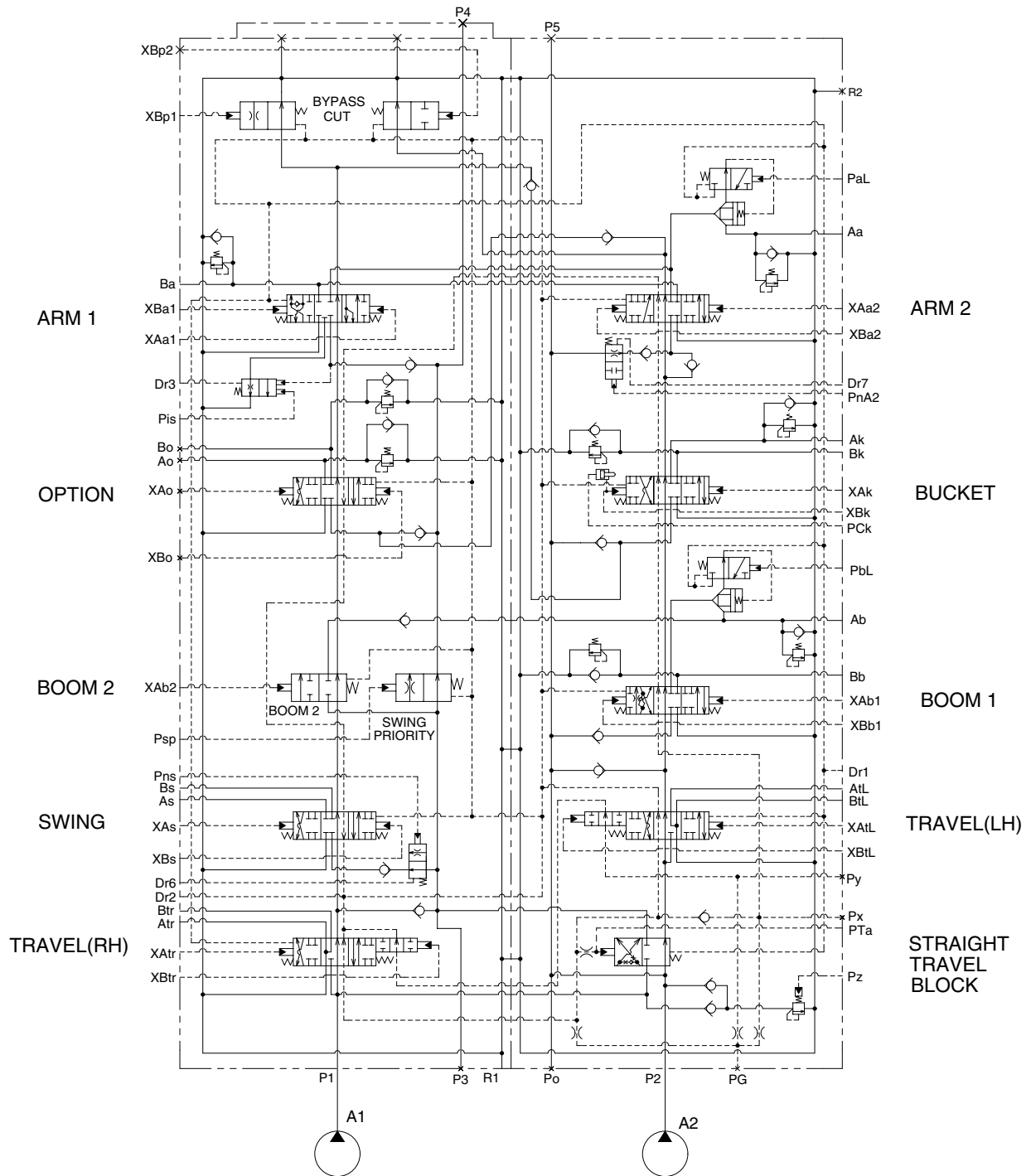

235A2MC12

3. FUNCTION

1) CONTROL IN NEUTRAL POSITION

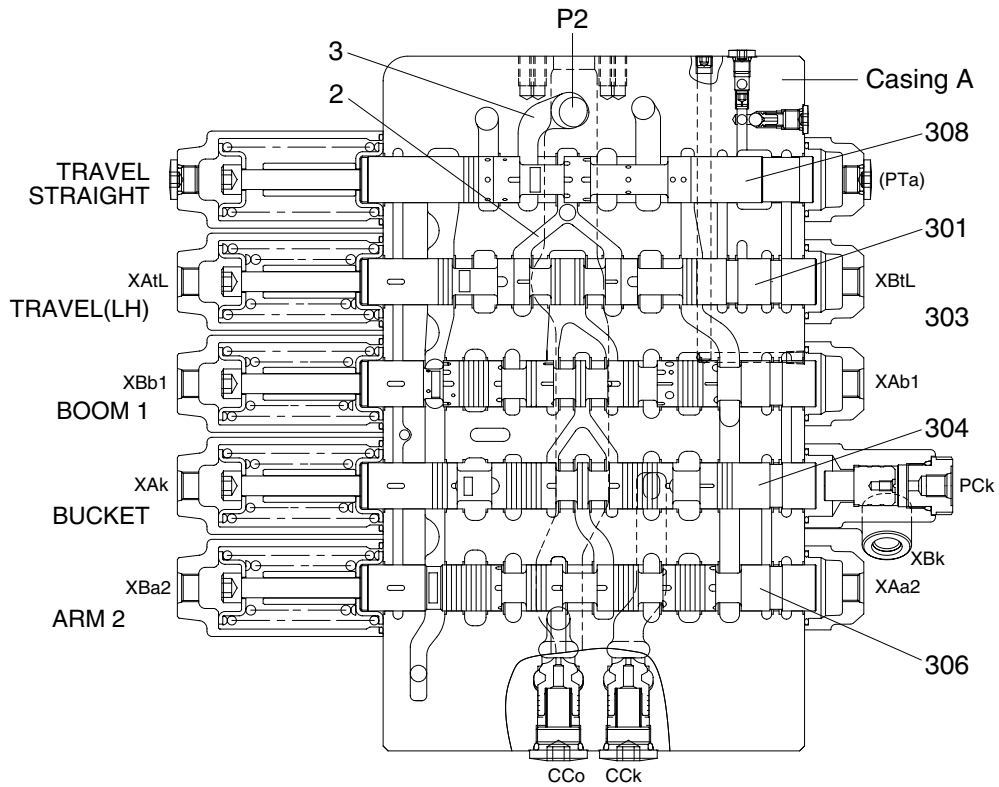

SPOOL SECTION (P2)

235A2MC15

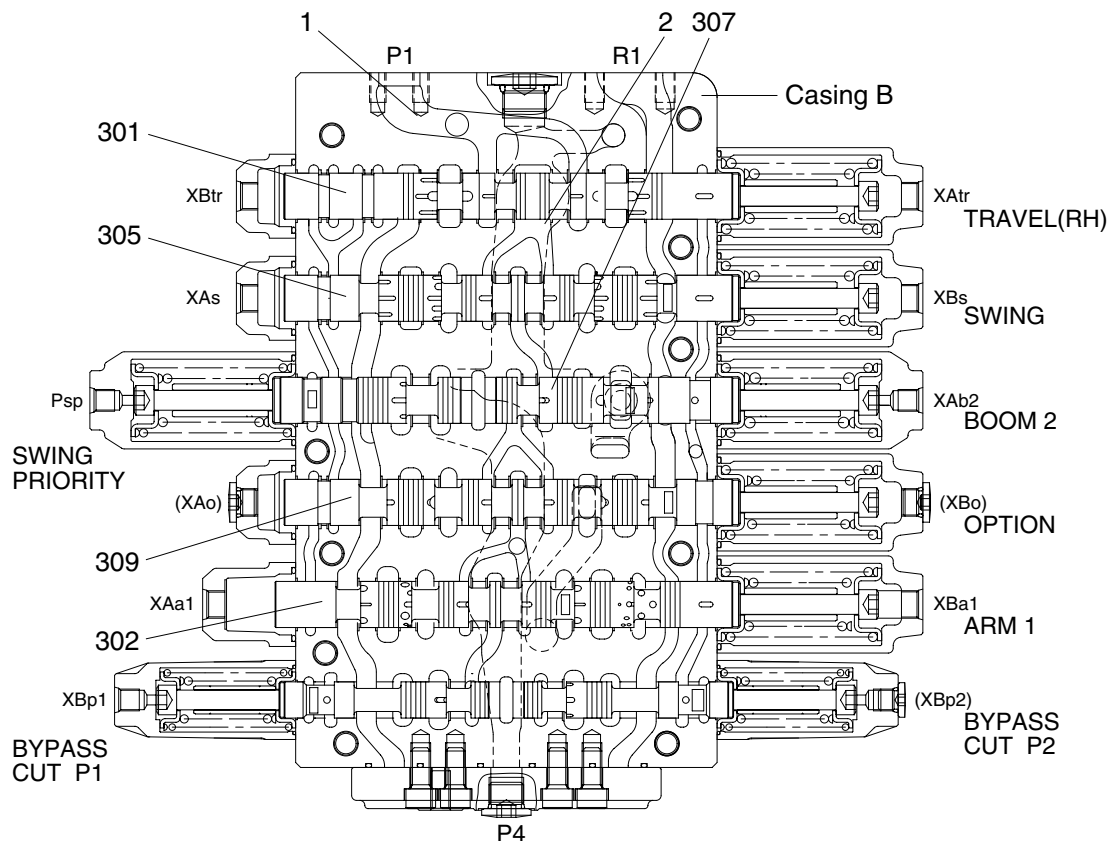

SPOOL SECTION (P1)

235A2MC16

When all spools are in the neutral positions, the pressurized oil discharged from the hydraulic pump (A1) passes through Port P1, the main path (1), the bypass circuit (2) passing the spools for travel right (301), swing (305), boom confluence (boom 2; 307), option (309) and arm 1 (302), and returns to the hydraulic oil tank through the tank port (R1).

The oil discharged from the hydraulic pump (A2) passes through Port P2, the main path (3), the bypass circuit (2) passing the spools for travel left (301), boom 1 (303), bucket (304) and arm 2 (306), and returns to the hydraulic oil tank through the tank port (R1).

RCV secondary pressure in neutral position of spool is led to electrically controlled regulator and controls the pump discharge flow rate to its minimum value.

2) EACH SPOOL OPERATION

(1) Boom operation

① Boom up operation

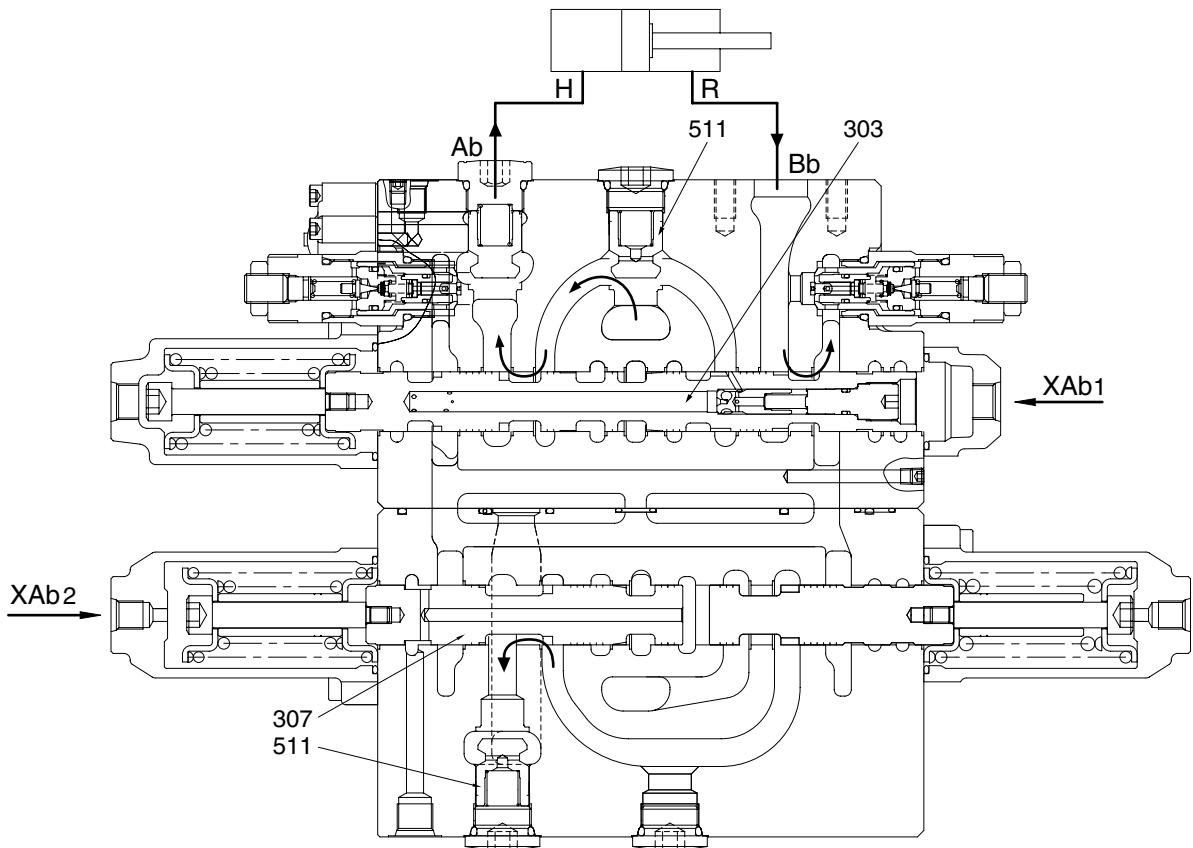

220F2MC17

Pilot circuit

Since the boom 1 spool (303) transfers and shuts off the side-bypass path, the pressure at Port XAb1, XAb2 increases.

Main circuit

During the boom up operation, the pilot pressure enters through Port XAb1 and moves the boom 1 spool (303) in the left direction. The pressurized oil entering through Port P2 passes through the main path (3) and flows to the bypass circuit (2), but the bypass circuit (2) is shut off due to transfer of the boom 1 spool (303). Therefore, the pressurized oil flows into the parallel circuit, pushes open the check valve (511), and flows through the U-shaped path to the boom 1 spool (303).

Then, it flows around the periphery of the boom 1 spool (303) to Port Ab, and is supplied to the boom cylinder head side (H).

At the same time, the pilot pressure enters also through Port XAb2 to transfer the boom 2 spool (307) in the right direction. Though the pressurized oil enters into Port P1, the bypass circuit (2) is shut off due to transfer of the boom 2 spool (307). Therefore, the hydraulic oil flows in the parallel circuit and flows through the U-shaped path to the boom 2 spool (307). Then, the hydraulic oil passes through the periphery of the boom 2 spool (307), pushes open the check valve (511), joins into Port Ab in the inside path, and is supplied to the boom cylinder head side. (Boom confluent flow)

On the other hand, the return oil from the boom cylinder rod side (R) enters through Port Bb and returns to the hydraulic oil tank through the tank port (R1).

② Boom down operation

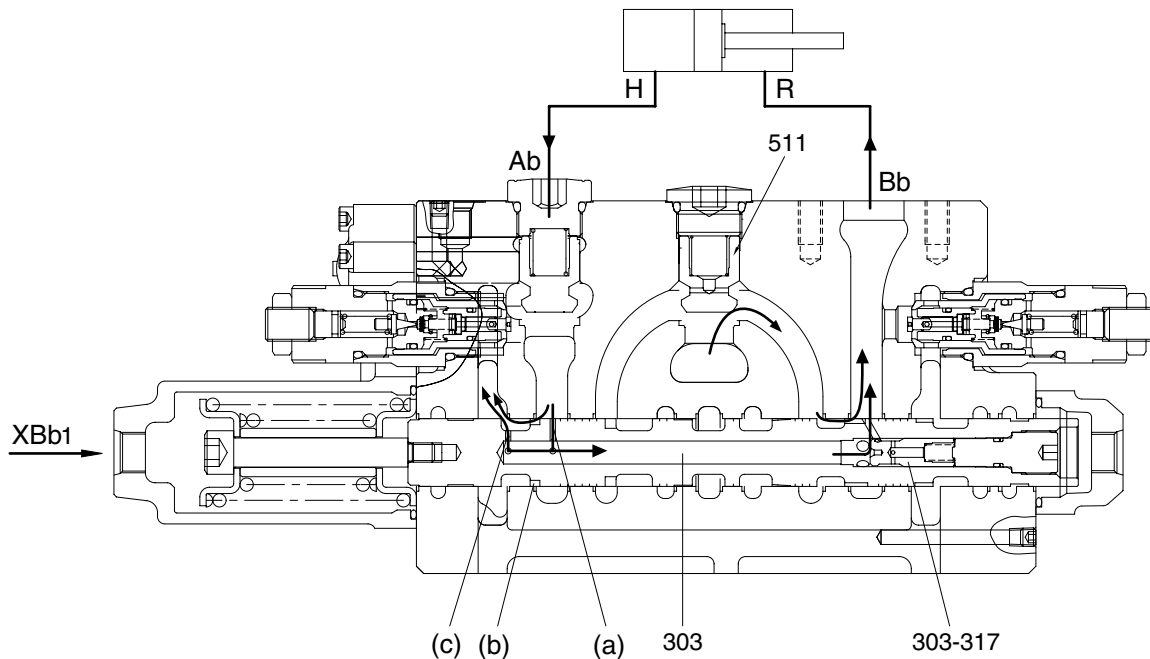

220F2MC52

Pilot circuit

Since the boom 1 spool (303) transfers and shuts off the side-bypass path, the pressure at Port XBb1 increases. Then, the pressure enters also through Port PbL and the release signal is sent to the lock valve (252).

Main circuit

During the boom down operation, the pilot pressure enters through Port XBb1 and transfers the boom 1 spool (303) in the right direction. The pressurized oil entering through Port P2 passes through the main path (3) and flows to the bypass circuit (2), but the bypass circuit (2) is shut off due to transfer of the boom 1 spool (303). Therefore, the pressurized oil flows into the parallel circuit, pushes open the check valve (511), and flows through the U-shaped path to the boom 1 spool (303). Then, it flows around the periphery of the boom 1 spool (303) to Port Bb and is supplied to the boom cylinder rod side (R).

On the other hand, the return oil from the boom cylinder head side (H) passes to the holes (a) and the notches (b) of the boom 1 spool (303).

Since this return oil has a sufficient pressure caused by the weight of the boom, it passes through the path inside the spool, pushes the poppet (303-317) in the spool in the right direction, flows around the outside of the spool. Then, it is supplied again to the boom cylinder rod side as hydraulic oil to lower the boom. (Boom regeneration)

Besides, a part of the return oil from the boom cylinder flows from the hole (c) into the tank.

(2) Arm operation

① Arm out operation

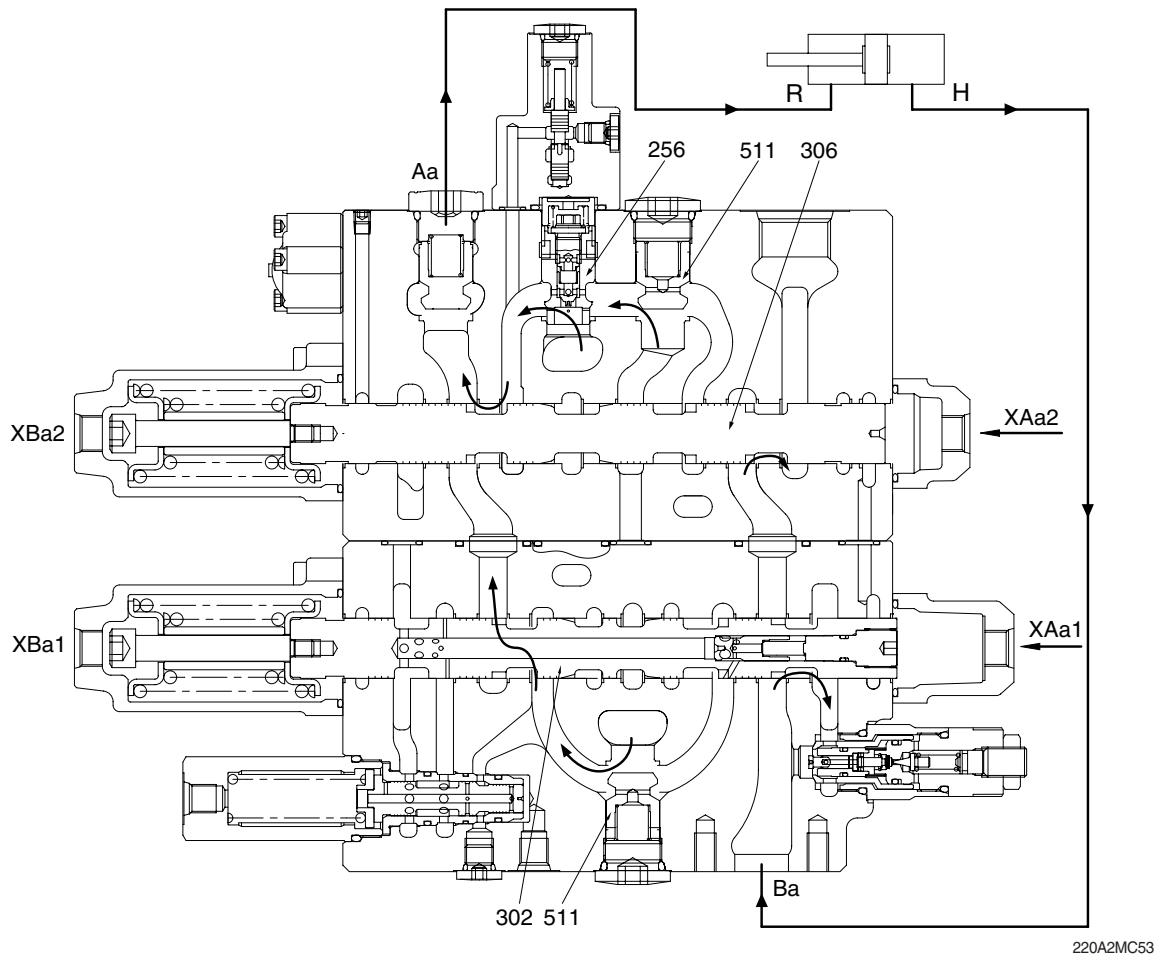

220A2MC53

Pilot circuit

Since the arm 2 spool (306) transfers and shuts off the side-bypass path, the pressure at Port XAa1, XAa2 increases.

Main circuit

During the arm out operation, the pilot pressure enters through Ports XAa1 and XAa2. When the pressure enters through Port XAa1 and XAa2, the spools transfer in the left direction. The hydraulic oil entering through Port P1 passes through the main path (1) and flows to the bypass circuit (2), but the bypass circuit is shut off due to transfer of the arm 1 spool (302).

Therefore, the hydraulic oil from the parallel circuit pushes open the check valve (511) and flows through the U-shaped path to the arm 1 spool (302). Then, it flows around the periphery of the arm 1 spool (302) and the arm 2 spool (306) to Port Aa, and is supplied to the arm cylinder rod side (R).

On the other hand, the hydraulic oil entering through Port P2 passes in the main path (3), and flows into the bypass circuit (2), and the bypass circuit is shut off due to transfer of the arm 2 spool (306). The hydraulic oil from the parallel circuit pushes open the logic poppet (256) and the hydraulic oil from the bypass circuit (2) pushes open the check valve (511) and flows through the U-shaped path to the arm 2 spool (306). Then, it flows around the periphery of the arm 2 spool (306) in the inside path and joins into Port Aa.

Besides, the return oil from the arm cylinder head side passes (H) through Port Ba, flows into tank line in arm 1 side and in arm 2 side, and returns to the hydraulic oil tank through the tank port (R1).

② Arm in operation
 · During light load only

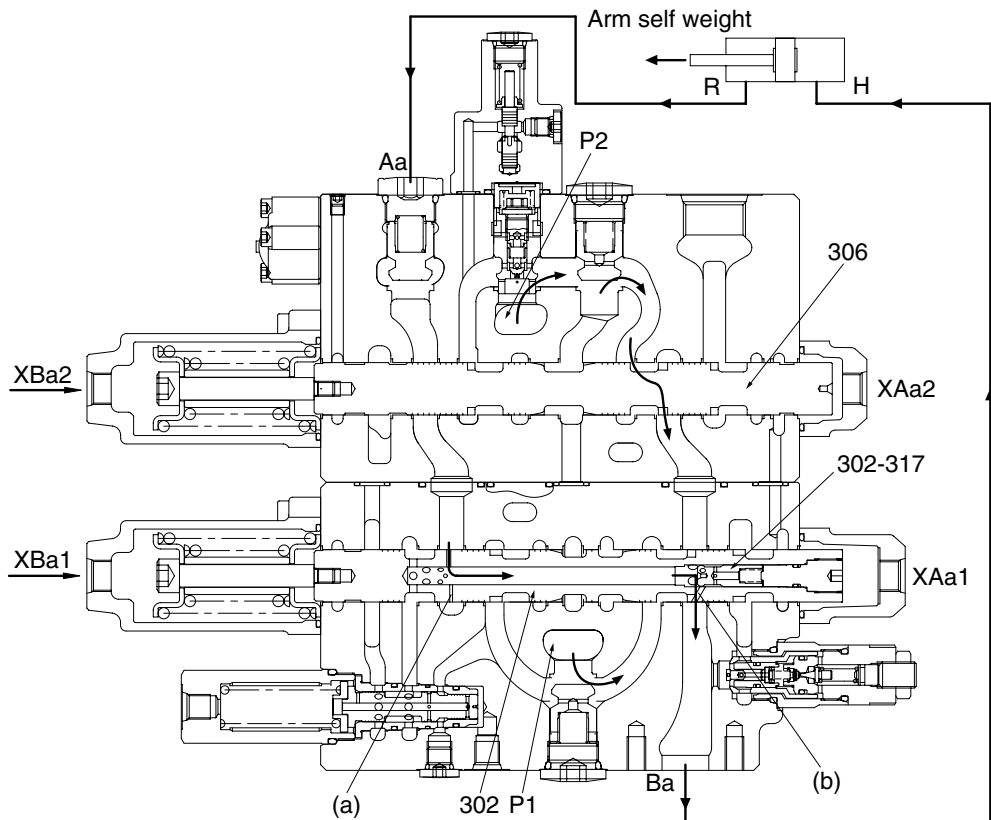

220A2MC54

Pilot circuit

Since the arm 2 spool (306) transfers and shuts off the side-bypass path, the pressure at Port XBa1, XBa2 increases. Then, the pressure enters also through Port PaL and the release signal is sent to the lock valve (252).

Main circuit

During the arm in operation, the pilot pressure enters through Ports XBa1 and XBa2. When the pressure enters through Port XBa1 and Port XBa2, the spools transfer in the right direction. The hydraulic oil entering through Port P1 passes through the main path (1) and flows to the bypass circuit (2), but the bypass circuit is shut off due to transfer of the arm 1 spool (302). Therefore, the hydraulic oil from the parallel circuit pushes open the check valve (511) and flows through the U-shaped path to the arm 1 spool (302). Then, it flows around the periphery of the arm 1 spool (302) to Port Ba, and is supplied to the arm cylinder head side (H).

On the other hand, the hydraulic oil entering through Port P2 passes in the main path (3), and flows into the bypass circuit (2), and the bypass circuit is shut off due to transfer of the arm 2 spool (306). The hydraulic oil from the parallel circuit pushes open the logic poppet (256) and the hydraulic oil from the bypass circuit (2) pushes open the check valve (511) and flows through the U-shaped path to the arm 2 spool (306). Then, it flows around the periphery of the arm 2 spool (306) and the arm 1 spool (302) in the inside path and joins into Port Ba.

Besides, the return oil from the arm cylinder rod side (R) is pressurized by self-weight of the arms and so on, and returns to Port Aa. The pressurized oil returning to Port Aa enters into the spool through the periphery hole (a) of the arm 1 spool (302). During a light load only, it pushes open the check valve (302-317) and joins into Port Ba from the spool hole (b). The rest of oil returns to the hydraulic oil tank through the tank port (R1). This is called the arm regeneration function.

· The pressure in the arm cylinder head side (H) increases

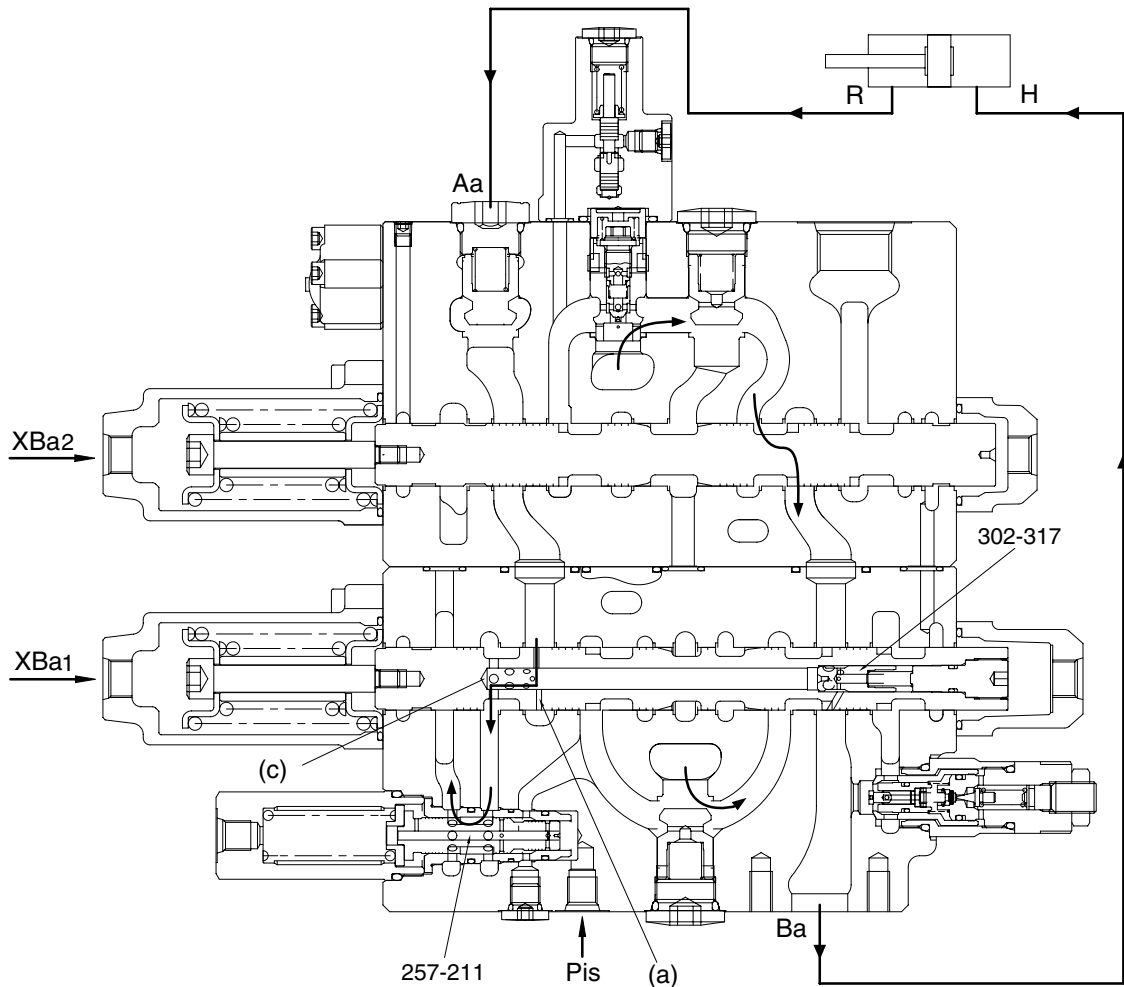

220A2MC55

When the pressure in the arm cylinder head side (H) and the U-shaped path increases, the arm regeneration cut spool (257-211) is transferred in the left direction, and at the same time the check valve (302-317) is closed by its backpressure. This shuts off the arm regeneration function, and the return oil from the arm cylinder rod side (R) enters from Port Aa through the periphery hole (a) of the arm 1 spool (302) into the spool, flows to the arm regeneration cut valve (257) through the periphery hole (c) of the arm 1 spool (302), and returns through the tank port (R1) to the hydraulic oil tank.

When the Pilot Port Pis of the arm regeneration cut spool (257-211) is pressurized, a part of the return oil from the arm cylinder rod side flows to the arm regeneration cut valve (257) and returns through the tank port (R1) to the hydraulic oil tank. (Variable arm regeneration)

③ Arm 2 logic control valve operation

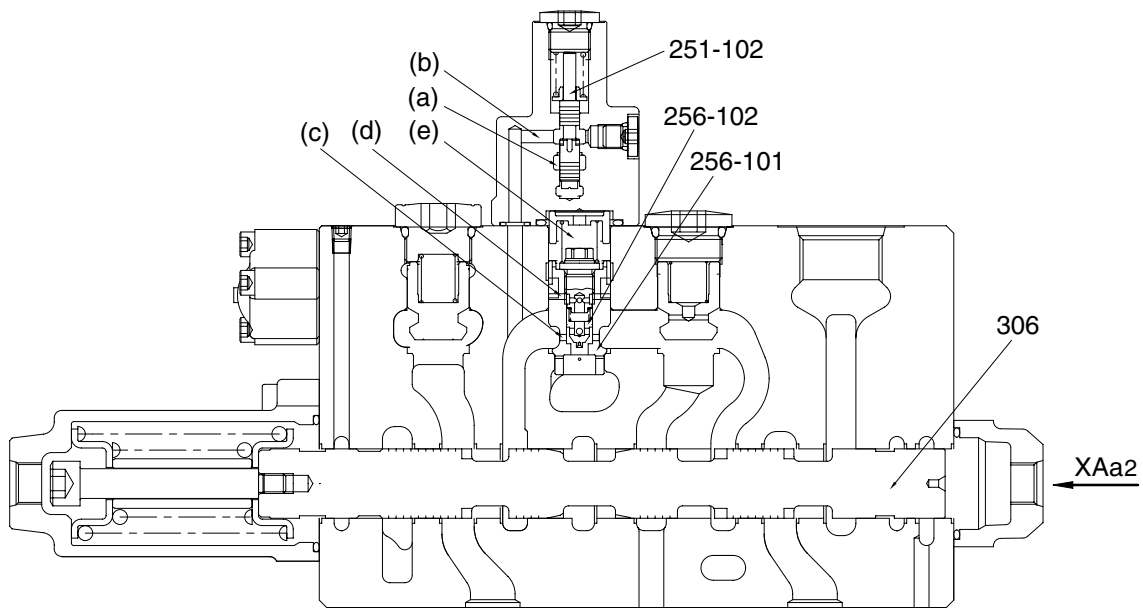

220A2MC116

During both the arm in operation and the boom up operation, the pilot pressure enters through Ports XBa1, XBa2, XAb1, XAb2, PaL and electrically controlled pilot pressure enters to PnA2. The pressure PnA2 transfers the spool (251-102) in the arm 2 logic control valve to the top direction, and the path from (a) to (b) is closed. Hereby, the pressurized oil pushes open the poppet (256-102), passes in the path (c) and (d), enters into the chamber (e), and the poppet (256-101) is pushed to the casing seat. Therefore, the most of pressurized oil entering through Port P2 flows to the boom 1 spool (303) than the arm 2 spool (306) to make the boom hoisting operation most preferential.

On the other hand, in the independent arm in operation, the pilot pressure does not enter through Ports PnA2, and the path from (a) to (b) is not closed, and the hydraulic oil of the chamber (e) flows to the path (a) and (b). The pressurized oil entering through Port P2 pushes open the poppet (256-101) and flows to the arm 2 spool (306).

(3) Bucket operation

① Bucket in operation

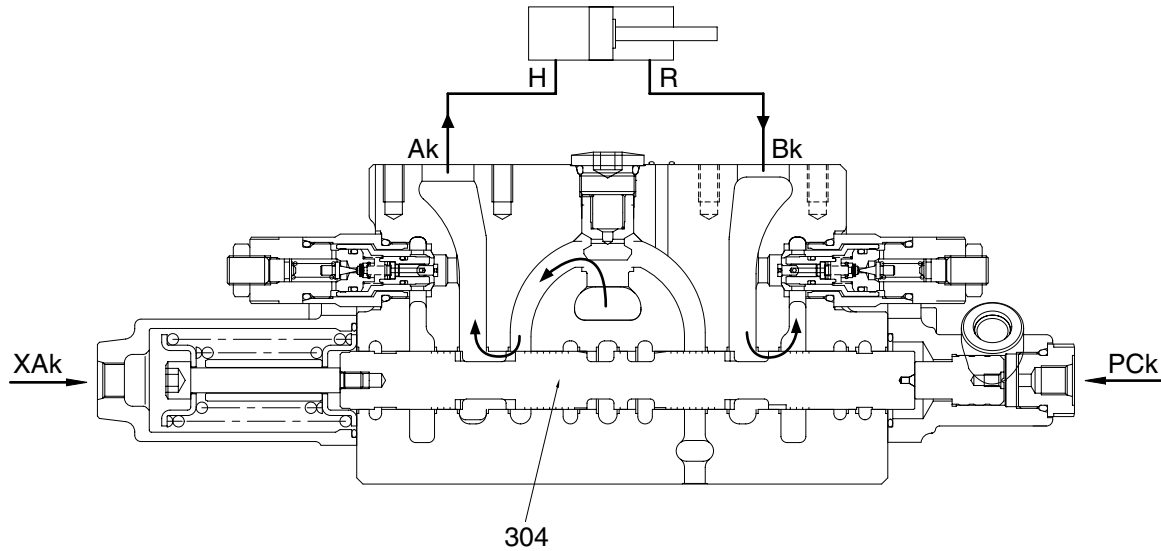

220F2MC57

Pilot circuit

Since the bucket spool (304) transfers and shuts off the side-bypass path, the pressure at Port XAk increases. Then, the pressure enters also through Port XBp1.

Main circuit

During the bucket in operation, the pilot pressure enters through Port XAk and transfers the bucket spool (304) in the right direction. The pressurized oil entering through Port P2 passes through the main path (3) and flows through the bypass circuit (2), but the bypass circuit (2) is shut off due to transfer of the bucket spool (304). Therefore, the pressurized oil flows into the parallel circuit, pushes open the check valve (511), and flows through the U-shaped path to the bucket spool (304). Then, it flows through the periphery of the spool to Port Ak and is supplied to the bucket cylinder head side (H).

On the other hand, the return oil from the bucket cylinder rod side (R) enters through Port Bk, passes around the periphery of the spool, and returns to the hydraulic oil tank through the tank port (R1).

During both the boom up operation and bucket in operation, the pilot pressure enters through Port PCk and the bucket spool transfers in the half stroke not full stroke. Therefore, the most of pressurized oil entering through Port P2 flows to the boom 1 spool (303) than the bucket spool (304) to make the boom up operation most preferential.

② Bucket out operation

Pilot circuit

Since the bucket spool (304) transfers and shuts off the side-bypass path, the pressure at Port XBk increases. Then, the pressure enters also through Port XBp1.

Main circuit

During the bucket out operation, the pilot pressure enters through Port XBk and transfers the bucket spool (304) in the left direction. The pressurized oil entering through Port P2 passes through the main path (3) and flows through the bypass circuit (2), but the bypass circuit (2) is shut off due to transfer of the bucket spool (304). Therefore, the pressurized oil flows into the parallel circuit, pushes open the check valve (511), and flows through the U-shaped path to the bucket spool (304). Then, it flows through the periphery of the spool to Port Bk and is supplied to the bucket cylinder rod side (R).

On the other hand, the return oil from the bucket cylinder head side (H) enters through Port Ak, passes around the periphery of the spool, and returns to the hydraulic oil tank through the tank port (R1).

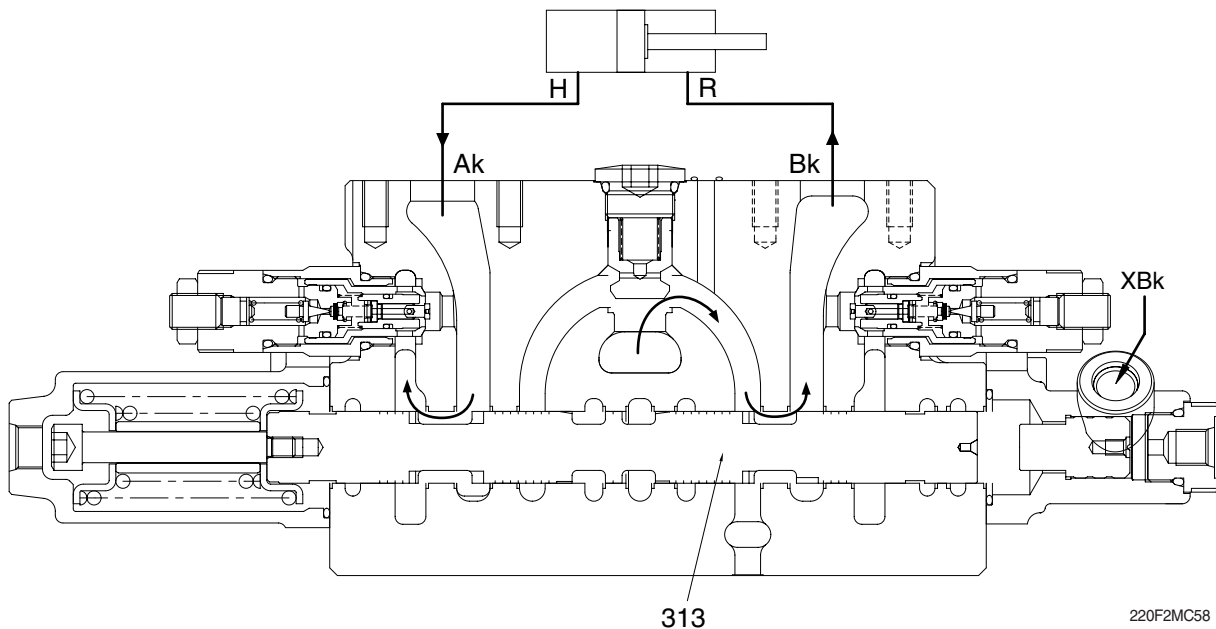

③ Bucket in/out confluence

During the bucket in/out operation, the pilot pressure enters also through Port XBp1 and transfers the bypass-cut spool (313). The pressurized oil entering through Port P1 passes through the main path (1) and flows through the bypass circuit (2), but the bypass circuit (2) is shut off due to transfer of the bypass-cut spool (313). Therefore, the pressurized oil pushes open the check valve CCK (514), and flows through inside path and the U-shaped path to the bucket spool (304).

(4) Swing operation

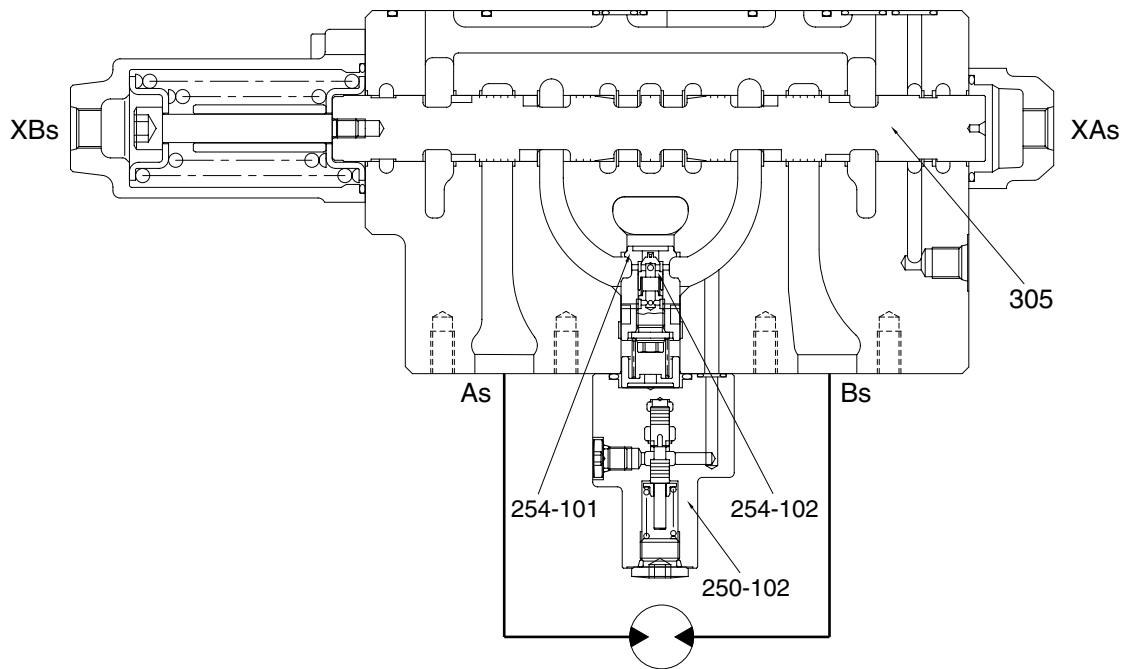

21092MC19

① Swing operation

Pilot circuit

Since the swing spool (305) transfers and shuts off the side-bypass path, the pressure at Port XAs (or XBs) increases.

Main circuit

During the swing operation, the pilot pressure enters through Port XAs (or XBs) and transfers the swing spool (305). The pressurized oil entering through Port P1 passes through the main path (1) and flows through the bypass circuit (2), but the bypass circuit (2) is shut off due to transfer of the swing spool (305). Therefore, the pressurized oil flows into the parallel circuit, pushes open the check valve (511), and flows through the U-shaped path to the swing spool (305). Then, it flows through the periphery of the spool to Port As (or Bs) and is supplied to the swing motor.

On the other hand, the return oil from the swing motor enters Port Bs (or As) and returns to the hydraulic oil tank through the tank port (R1).

② Swing logic control valve operation

During both the swing operation and the boom up operation, the pilot pressure enters through Ports XBs (or XAs), XAb1, XAb2 and electrically controlled pilot pressure enters to PnA2. The pressure Pns transfers the spool (250-102) in swing logic control valve. Hereby, the pressurized oil pushes open the poppet (254-102), and the poppet (254-101) is pushed to the casing seat. Therefore, the most of pressurized oil entering through Port P1 flows to the boom 2 spool (307) than the swing spool (305) to make the boom up operation most preferential.

On the other hand, in the independent swing operation, the pilot pressure does not enter through Ports Pns. The pressurized oil entering through Port P1 pushes open the poppet (254-101) and flows to the swing spool (305).

③ Swing operation preference function

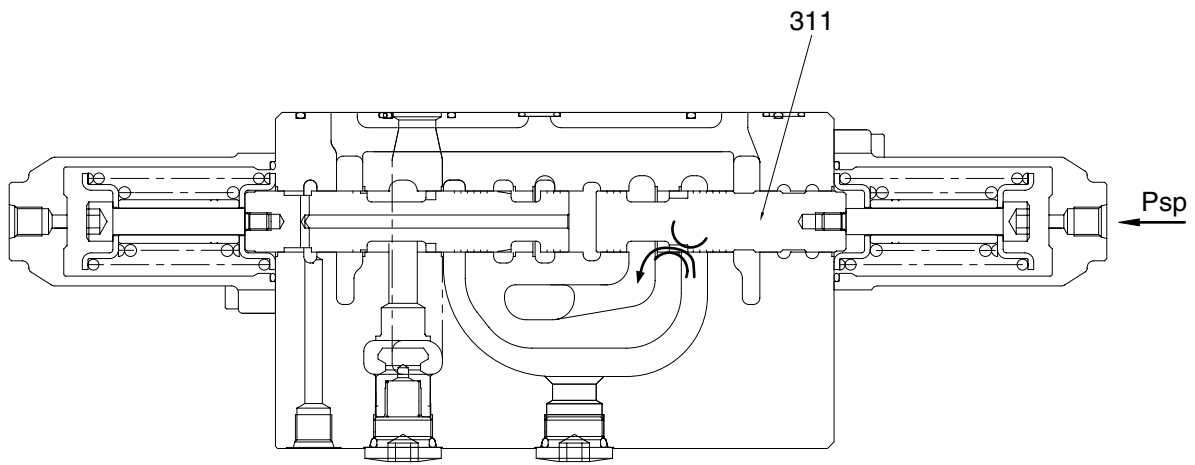

21092MC20

Pilot circuit

The pilot pressure enters through Port Psp to transfer the swing priority spool (311).

Main circuit

Due to transfer of the swing priority spool (311), the open area of the swing priority spool decreases, and the most of the pressurized oil entering through Port P1 flows to the swing side to make the swing operation most preferential.

(5) Travel operation

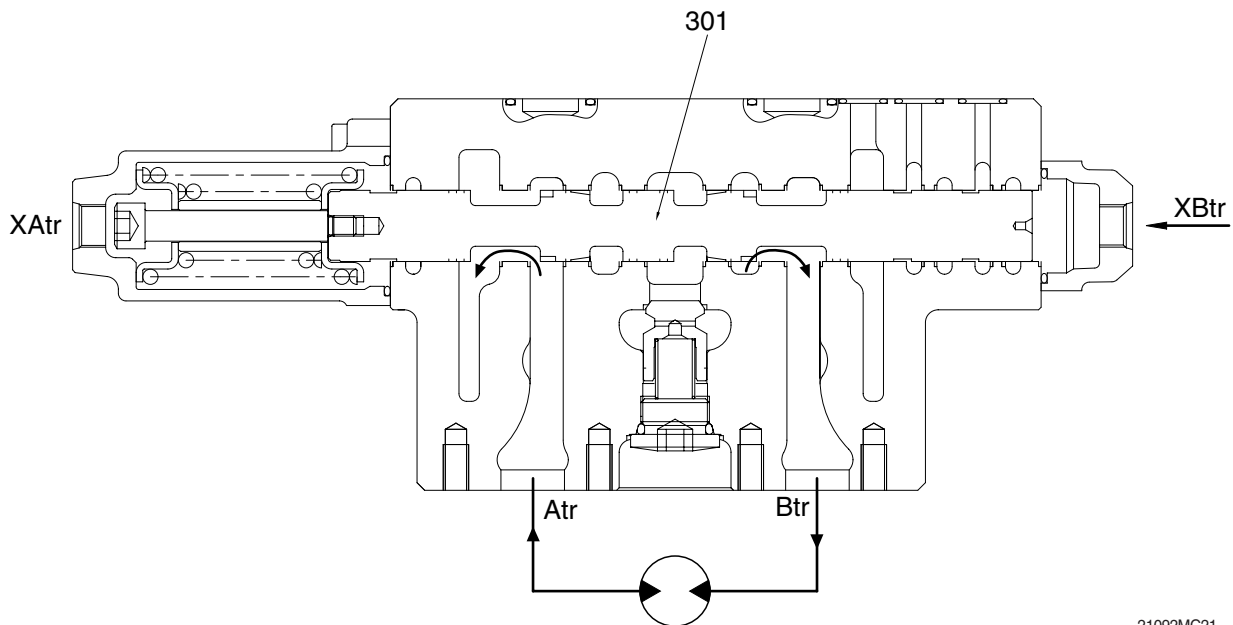

Pilot circuit

Since any of the travel spools (301) on the left or right transfers and shuts off the side-bypass path, the pressure at Port XBtr (or XAtr) increases.

Main circuit

When Pilot Port XBtr of the travel right spool (301) is pressurized, the bypass circuit (2) in the arm 1 side is shut off and the working fluid discharged from the hydraulic pump (A1) through Port Btr and flows to the travel right motor.

When Pilot Port XBtL of the travel left spool (301) is pressurized, the bypass circuit (2) in the boom 1 side is shut off and the working fluid discharged from the hydraulic pump (A2), similarly to that from the hydraulic pump (A1), through Port BtL and flows to the travel left motor.

On the other hand, the return oil from the right and left travel motor passes flows from Port Atr (AtL) to the travel right (left) spools (301) and returns to the hydraulic oil tank through the tank port (R1). In the case of the opposite operation (when the pilot pressure is applied to Ports XAtr and XAtL of the control valve), the operation is similar.

(6) Travel straight operation

Simultaneous operating of both travel spools (301) and other spool.

The following the case that both travel spools (301) and swing spool (305) are changed over.

(When the pilot Ports XAtL, XAtR and XAs are pressurized.)

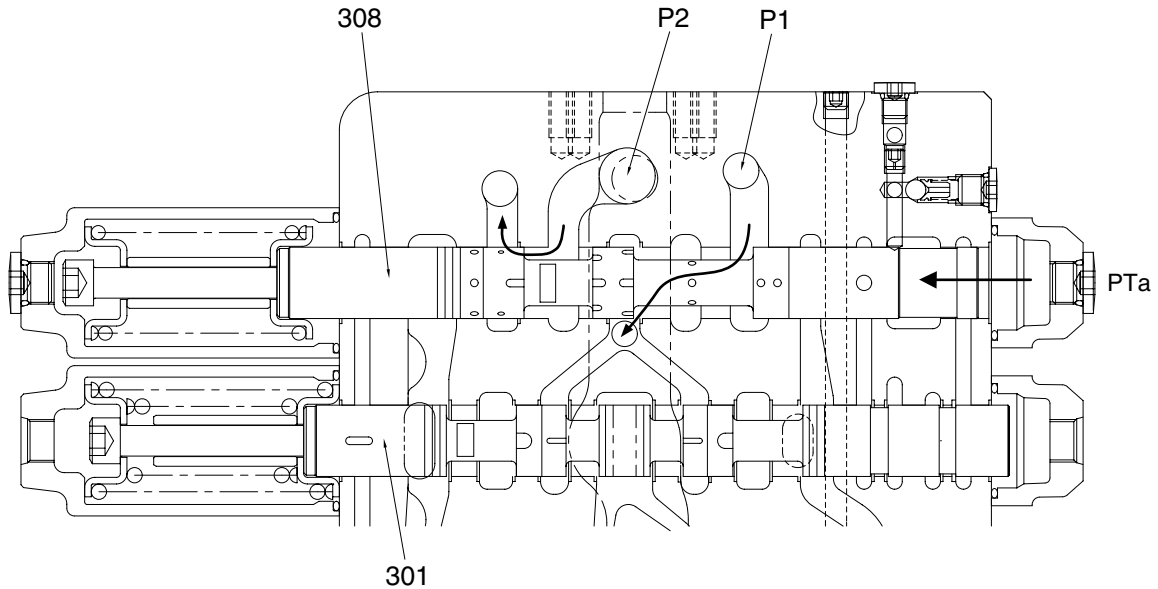

220A2MC22

Pilot circuit

Since the side bypass sections of both travel spools (301) close and the side bypass section of the downstream-side swing closes, the pilot pressure from the port PG enters through the port PTa to transfer the travel straight spool (308).

Main circuit

After changeover of the travel straight spool (308), the port P1 and both travel spools (301) are connected preferentially and the port P2 and the parallel paths of swing, boom 2, option and arm 1 / boom 1, bucket and arm 2 are connected preferentially. Therefore, the pressurized oil entering through Port P1 passes through mainly ports AtL and Atr, and flows to both travel motors separately.

On the other hand, the pressurized oil entering through Port P2 flows to Port As and is supplied to the swing motor.

When the pressure of Port P1 is lower than the pressure of Port P2, the part of oil entering through Port P2 flows into Port P1 side. Therefore, it prevents the travel velocity from slowing rapidly.

3) FUNCTION OF LOCK VALVE

The lock valve (252) is fitted between the arm cylinder rod side (R) and the arm 2 spool (306). It decreases the leakage by the pressure of the cylinder.

Another lock valve (252) is similarly fitted between the boom cylinder head side (H) and the boom 1 spool (303). It decreases the leakage by the pressure of the cylinder.

(1) Neutral positions of spools

The following is the case of the boom 1 spool (303). (The case of the arm 2 spool (306) is in the same way.)

During the boom 1 spool (303) is in the neutral position, the lock valve (252) is kept in the position shown in figure. The spool (252-511) in the lock valve is pushed to the seat of the sleeve (252-541) by the force of the spring (252-321).

In this position, the pressurized oil from the boom cylinder head side (H) enters through the hole (a), the periphery of the spool (252-511) in the lock valve and the hole (b), and it pushes the poppet (513) to the casing seat, and the leakage is decreased.

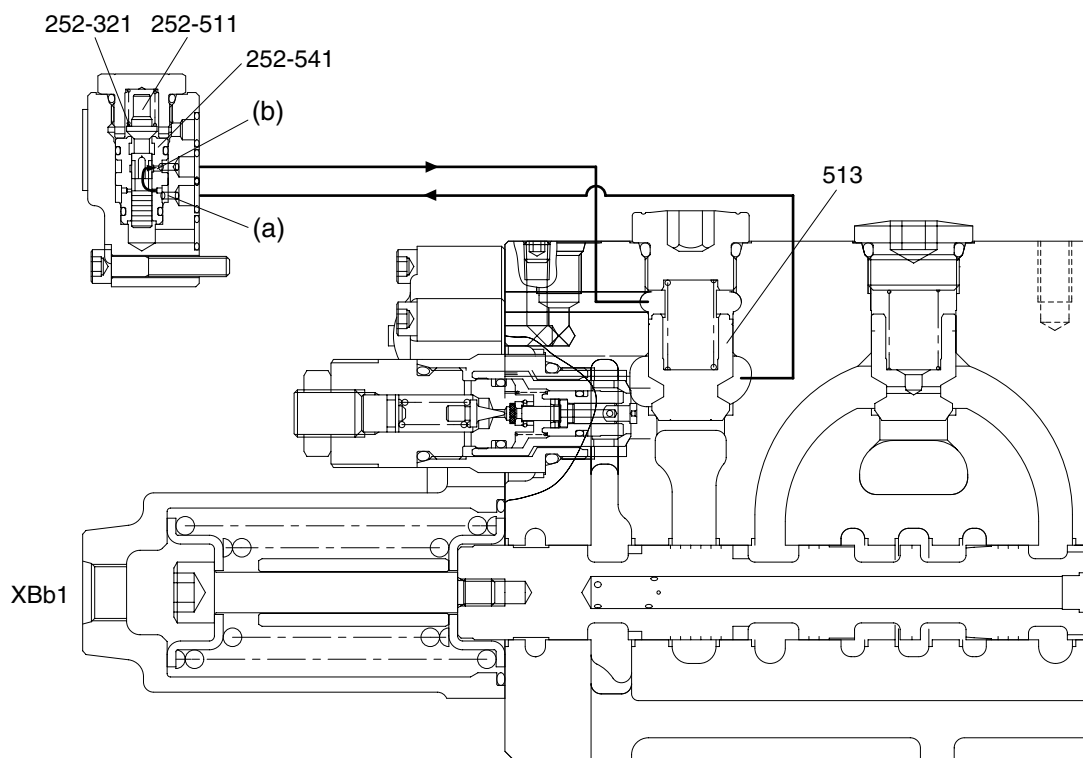

220A2MC135

(2) Boom down operation

During the boom down operation, the pilot pressure enters through Port PbL and XBb1. The pilot pressure transfers the spool (252-511) in the lock valve assy in the top direction. By the transfer of the spool (252-511), firstly the hole (a) is blocked and the flow of oil from the boom cylinder head side (H) to the spring chamber (RH) stops. Secondly, the oil in the spring chamber (RH) enters through the hole (b) and flows to drain circuit. Therefore, the poppet (513) is lifted by the pressure of the boom cylinder head side (H) and the function of the lock valve (252) is released.

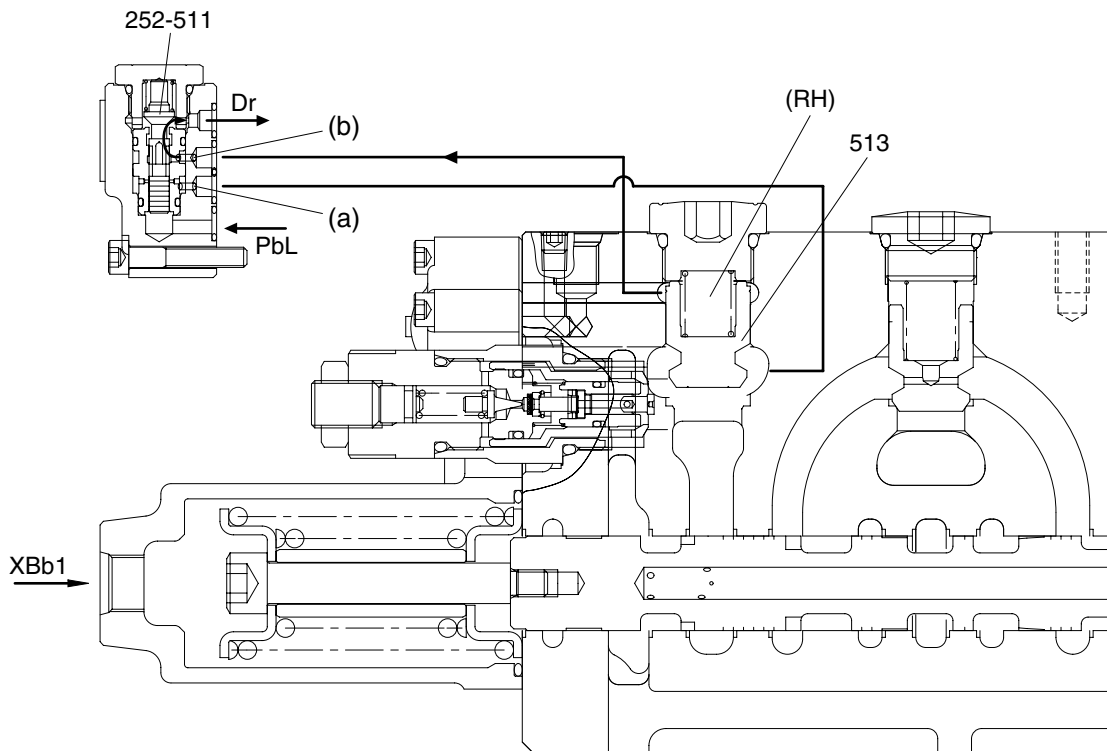

220A2MC136

(3) Boom up operation

During the boom up operation, the pilot pressure enters through Port XAb1. The oil flowing from the boom 1 spool pushes open the poppet (513) and flows to Port Ab.

4) CIRCUIT PRESSURE PROTECTION

The control valve has two kinds of relief valve to limit the pressure in a circuit.

(1) Main relief valve

The main relief valve is fitted in the P2 housing and functions as follows.

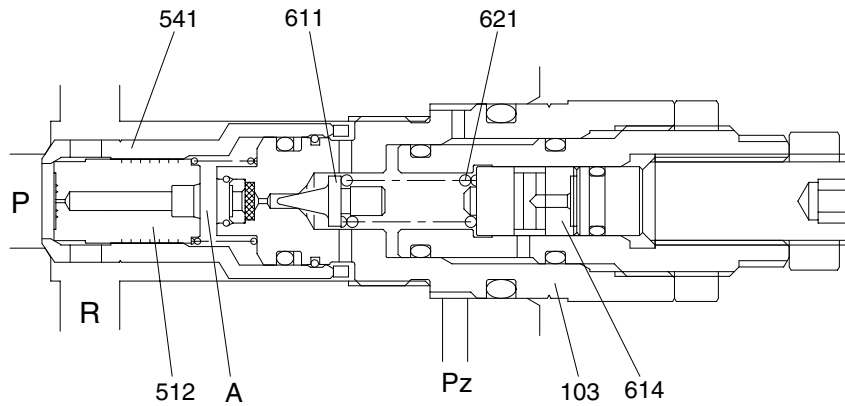

21092MC25

- ① The hydraulic oil is filled up in the inside space chamber (A) from the path (P) through a hole of the seat (541) and a restriction of the plunger (512), and seats the plunger (512) against the seat (541) securely.
- ② When the pressure in the path (P) becomes equal to the set load of the spring (621), the poppet (611) opens to make the hydraulic oil flow through a hole of the plug (103), around the poppet (611) and the hydraulic oil flow into the low pressure path (R).
- ③ Opening of the poppet (611) causes the pressure in the chamber (A) to fall and the plunger (512) to open. As the result the pressurized oil in the path (P) runs into the low pressure path (R) directly.
- ④ When the pressurized oil over 30 kgf/cm² enters through the port Pz, it pushes the piston (614), changes the relief set pressure of the spring (621) to the high pressure.

(2) Port relief valve

The port relief valve is fitted between the cylinder port and low-pressure path. In addition to the relief valve, it has the function of an anti-cavitation check valve, and functions as follows:

① Function as relief valve

- a. The pressurized oil passes through Hole A of the piston (301), fills Chamber B, and seat the plunger (511) against the seat (541) securely.

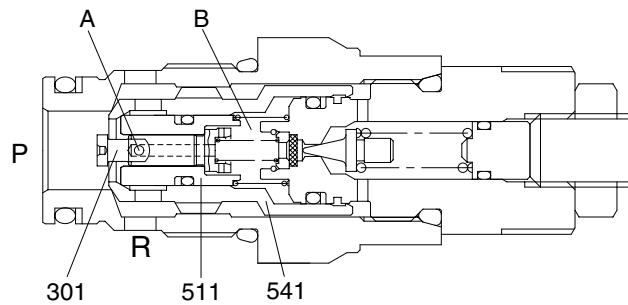
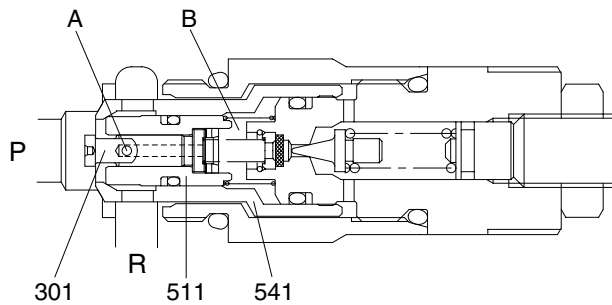

220F2MC66

- b. When the pressure in the path (P) exceeds the set pressure of the spring (621 or 622), the pressurized oil pushes open the poppet (611), flows around it, and flows to the low pressure path (R) through hole C.

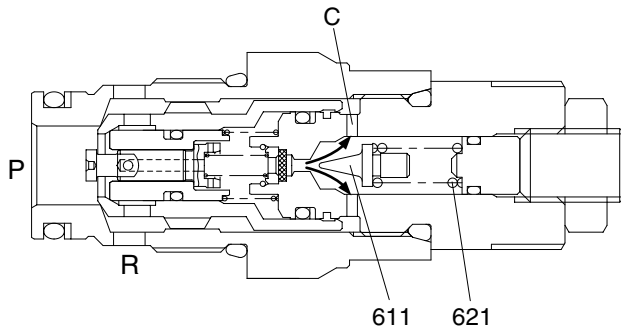
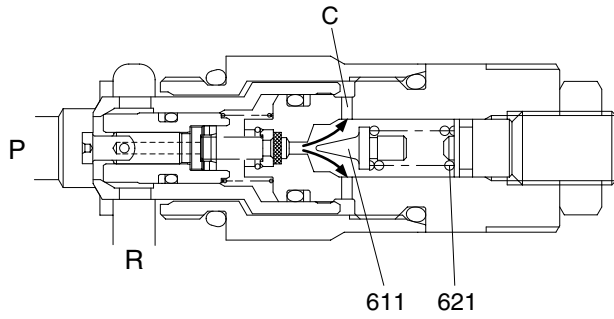

220F2MC67

- c. Opening of the poppet (611) causes the pressure in Chamber B to fall and the plunger (511) to open. As the result the pressurized oil in the path (P) runs into the low pressure path (R) directly.

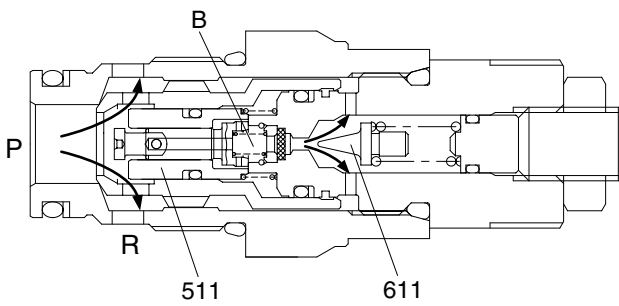
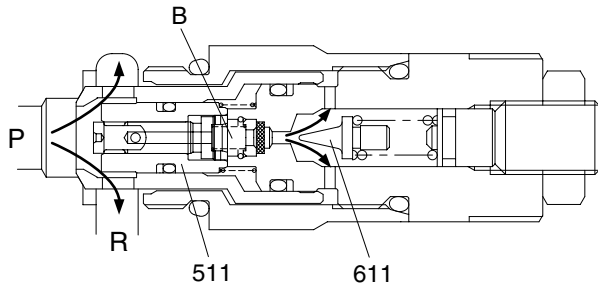

220F2MC68

② **Function as Anti-Cavitation Check Valve**

When any negative pressure exists in the path (P), the oil is supplied through the path (R). When the pressure at the path (R) exceeds it in the path (P), the seat (541) moves in the right direction. Then, sufficient oil passes from the path (R) to the path (P) around the seat (541) and prevents cavitation.

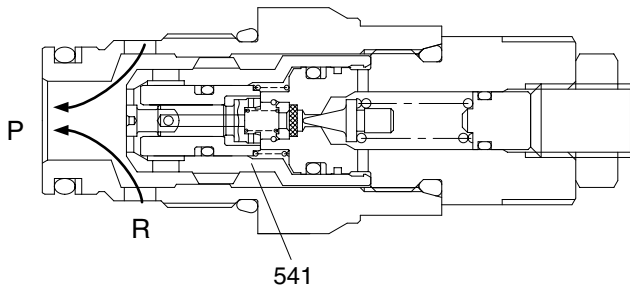
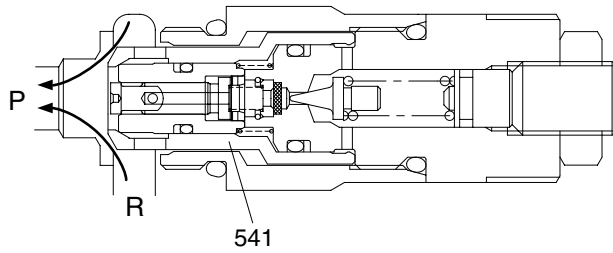

220F2MC69

GROUP 3 SWING DEVICE

1. STRUCTURE

Swing device consists swing motor and swing reduction gear.

Swing motor include mechanical parking valve, relief valve, make up valve and port block assy.

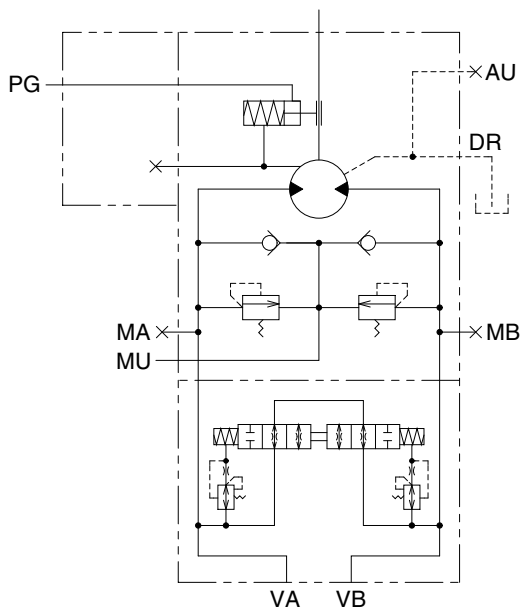
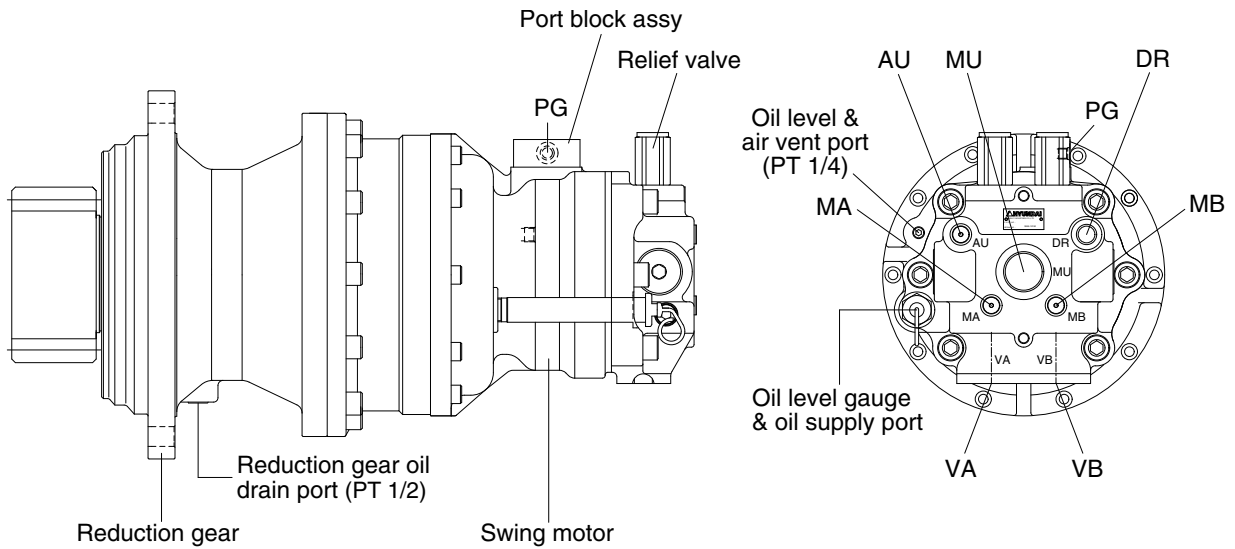

Hydraulic circuit

Port	Port name	Port size
VA	Main port	Ø20
VB	Main port	Ø20
DR	Drain port	PF 1/2
MU	Make up port	PF 1 1/4
PG	Brake release port	PF 1/4
MA, MB	Gauge port	PF 1/4
AU	Air vent port	PF 1/4

235A2SM01

1) SWING MOTOR

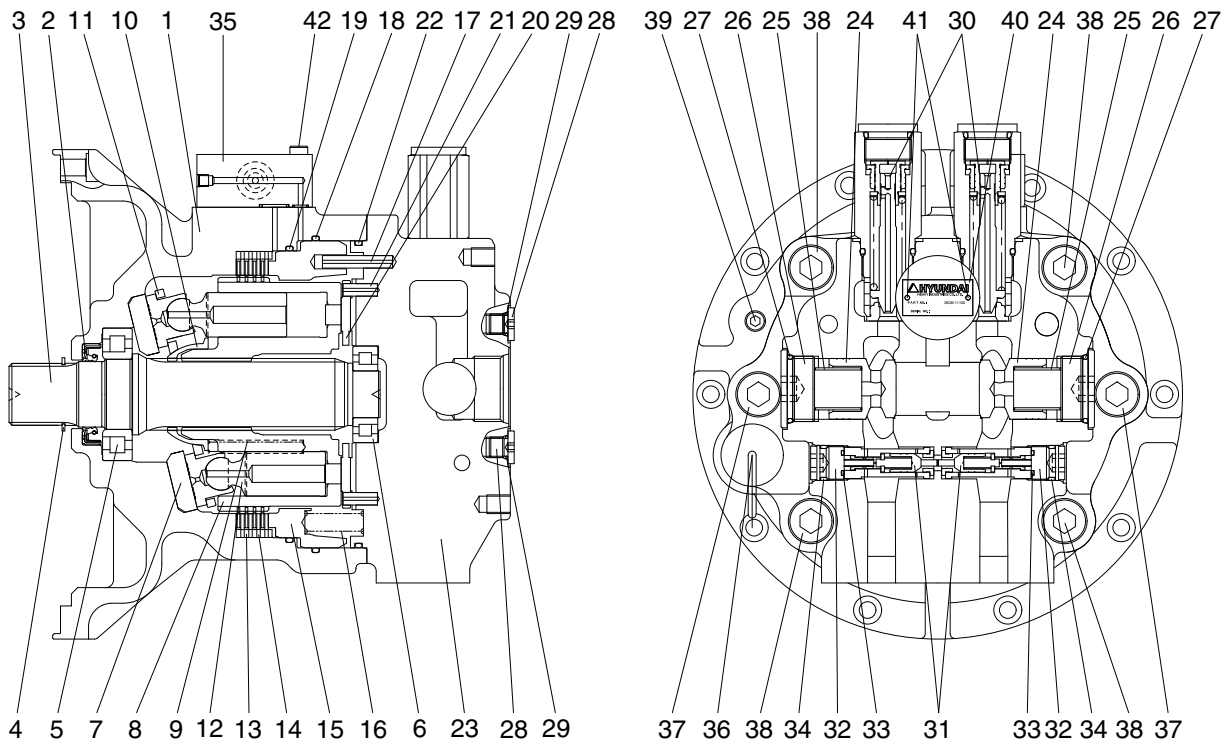

235A2SM02

1	Casing	15	Parking piston	29	O-ring
2	Oil seal	16	Brake spring	30	Relief valve assy
3	Shaft	17	Spring pin	31	Anti-rotation valve assy
4	Snap ring	18	O-ring	32	Plug
5	Roller bearing	19	O-ring	33	O-ring
6	Roller bearing	20	Valve plate	34	O-ring
7	Swash plate	21	Spring pin	35	Port block assy
8	Cylinder block	22	O-ring	36	Level gauge assy
9	Spring	23	Valve casing	37	Socket bolt
10	Ball guide	24	Check valve	38	Socket bolt
11	Retainer plate	25	Spring	39	Plug
12	Piston assy	26	Plug	40	Name plate
13	Friction plate	27	O-ring	41	Rivet
14	Separate plate	28	Plug	42	Hex socket bolt

2) REDUCTION GEAR

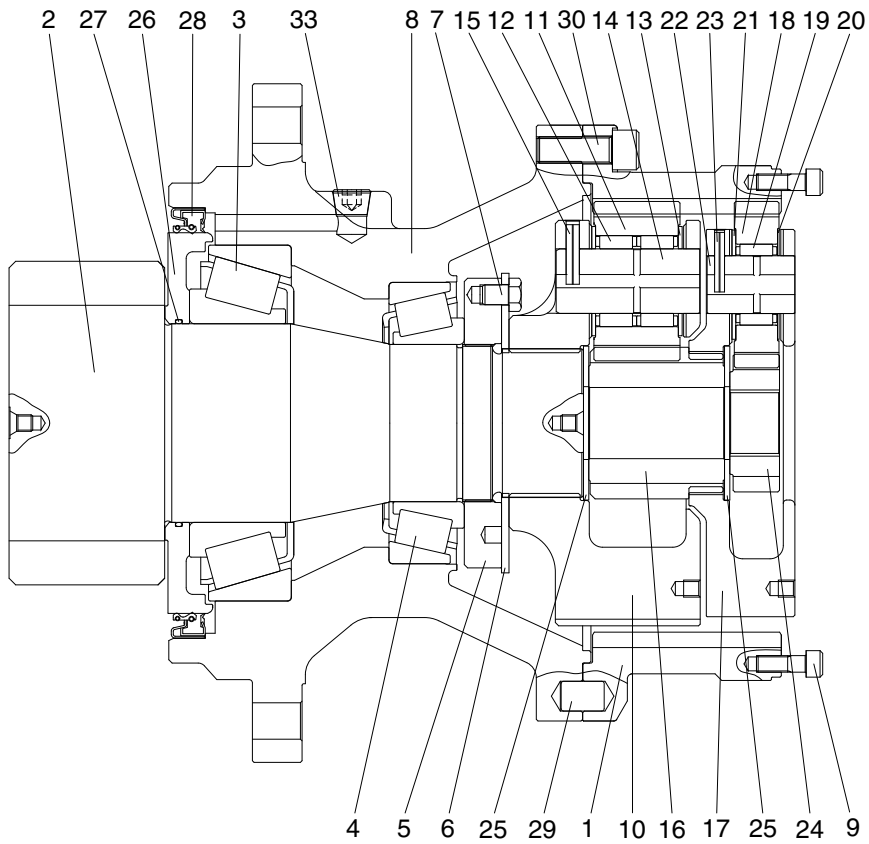

235ZF2SM03

- | | | | | | |
|----|----------------------|----|-------------------------|----|--------------|
| 1 | Ring gear | 12 | Needle bearing 2 | 23 | Spring pin 1 |
| 2 | Drive shaft | 13 | Thrust washer 2 | 24 | Sun gear 1 |
| 3 | Taper roller bearing | 14 | Carrier pin 2 | 25 | Thrust plate |
| 4 | Taper roller bearing | 15 | Spring pin 2 | 26 | Sleeve |
| 5 | Ring nut | 16 | Sun gear 2 | 27 | O-ring |
| 6 | Lock plate | 17 | Carrier 1 | 28 | Oil seal |
| 7 | Hexagon bolt | 18 | Planetary gear 1 | 29 | Parallel pin |
| 8 | Casing | 19 | Needle bearing 1 | 30 | Socket bolt |
| 9 | Socket bolt | 20 | Thrust washer 1 (upper) | 33 | Plug |
| 10 | Carrier 2 | 21 | Thrust washer 1 (lower) | | |
| 11 | Planetary gear 2 | 22 | Carrier pin 1 | | |

2. PRINCIPLE OF DRIVING

2.1 Generating the turning force

The high hydraulic supplied from a hydraulic pump flows into a cylinder block (8) through valve casing of motor (23), and valve plate (20).

The high hydraulic is built as flowing on one side of Y-Y line connected by the upper and lower sides of piston (12).

The high hydraulic can generate the force, $F1 = P \times A$ (P : supplied pressure, A : water pressure area), like following pictures, working on a piston.

This force, $F1$, is divided as $N1$ thrust partial pressure and $W1$ radial partial pressure, in case of the plate of a tilt angle, α .

$W1$ generates torque, $T = W1 \times R1$, for Y-Y line connected by the upper and lower sides of the piston as following pictures.

The sum of torque ($\sum W1 \times R1$), generated from each piston (4~5 pieces) on the side of a high hydraulic, generates the turning force.

This torque transfers the turning force to a cylinder (8) through a piston; because a cylinder is combined with a turning axis and spline, a turning axis rotates and a turning force is sent.

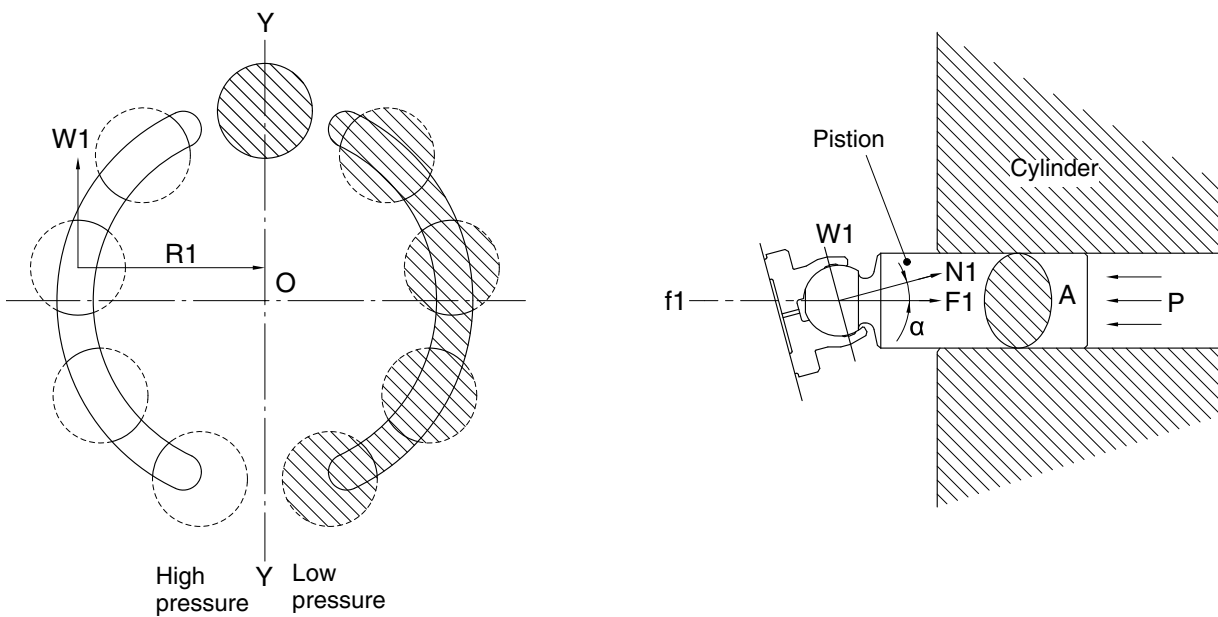

235ZF8TM05

2) MAKE UP VALVE

In the system using this type of motor, there is no counter balance functioning valve and there happens the case of revolution exceeding hydraulic supply of motor. To prevent the cavitation caused by insufficient oil flow there is a make up valve to fill up the oil insufficiency.

A make up valve is provided immediately before the port leading to the hydraulic oil tank to secure feed pressure required when the hydraulic motor makes a pumping action. The boost pressure acts on the hydraulic motor's feed port via the make up valve.

Pressurized oil into the port B, the motor rotate counterclockwise.

If the plunger of MCV moves neutral position, the oil in the motor is drain via left relief valve, the drain oil run into motor via right make up valve, which prevent the cavitation of motor.

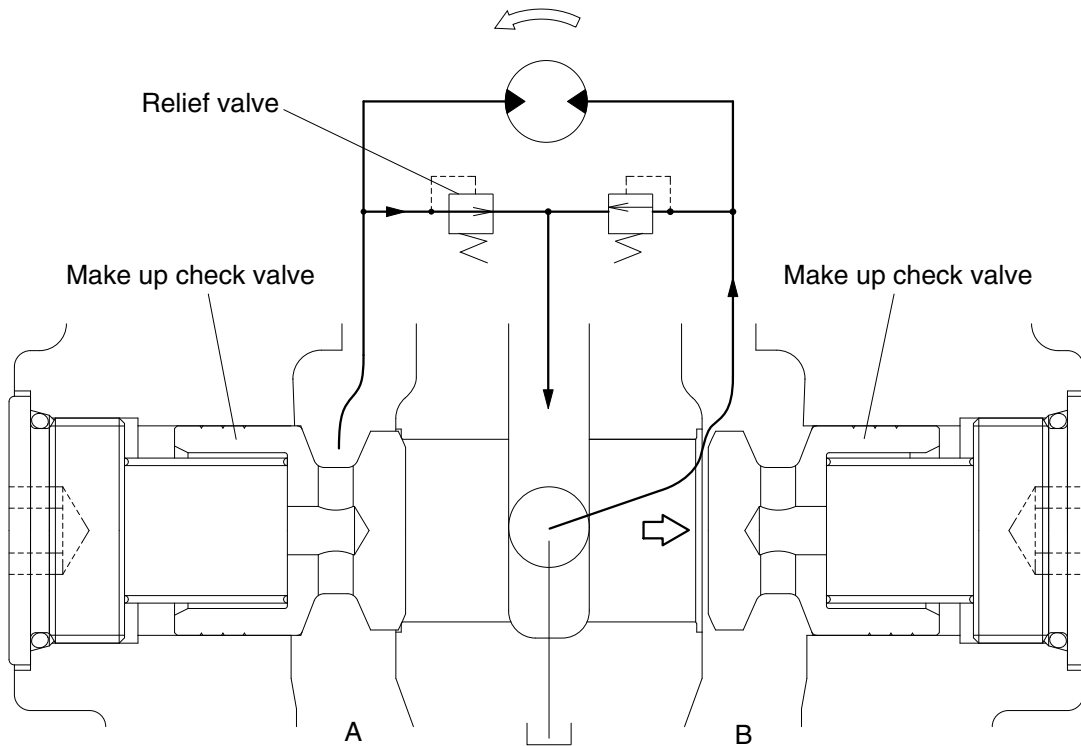

235ZF2SM04

3) RELIEF VALVE

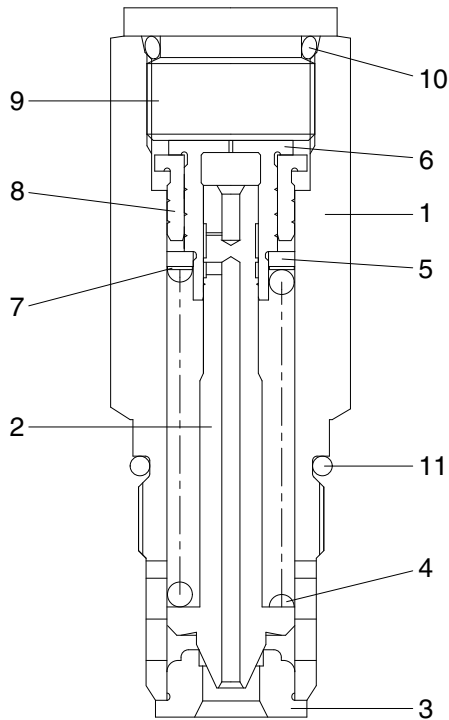

- 1 Sleeve
- 2 Poppet
- 3 Poppet seat
- 4 Spring
- 5 Spring seat
- 6 Shim
- 7 Piston
- 8 Stopper
- 9 Plug
- 10 O-ring
- 11 O-ring

235ZF2SM25

(1) Construction of relief valve

The valve casing contains two cartridge type relief valves that stop the regular and reverse rotations of the hydraulic motor. The relief valves relieve high pressure at start or at stop of swing motion and can control the relief pressure in two steps, high and low, in order to insure smooth operation.

(2) Function of relief valve

Figure illustrates how the pressure acting on the relief valve is related to its rising process. Here is given the function, referring to the figure following page.

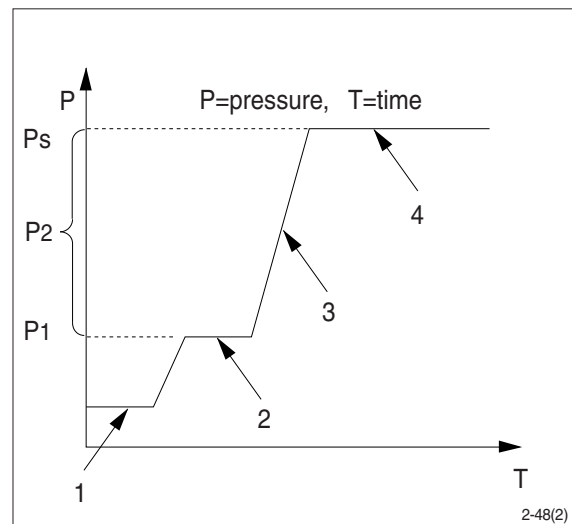

① Ports (P, R) at tank pressure.

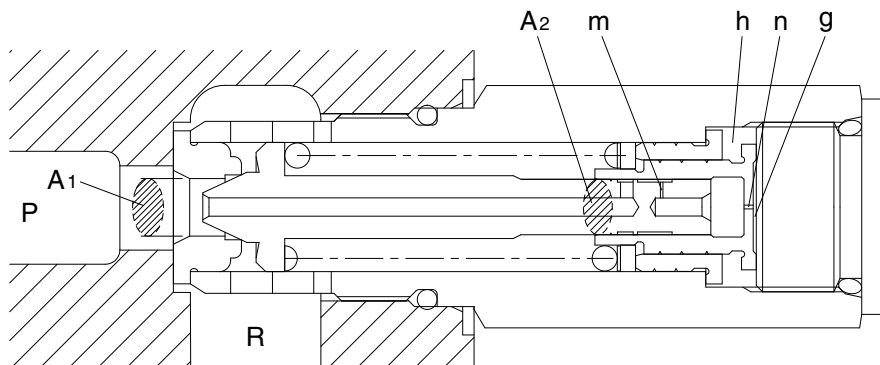

235ZF2SM26

② When hydraulic oil pressure ($P \times A_1$) reaches the preset force (F_{SP}) of spring (4), the plunger (2) moves to the right as shown.

$$P_1 \times A_1 = F_{SP} + P_g \times A_2$$

$$P_1 = \frac{F_{SP} + P_g \times A_2}{A_1}$$

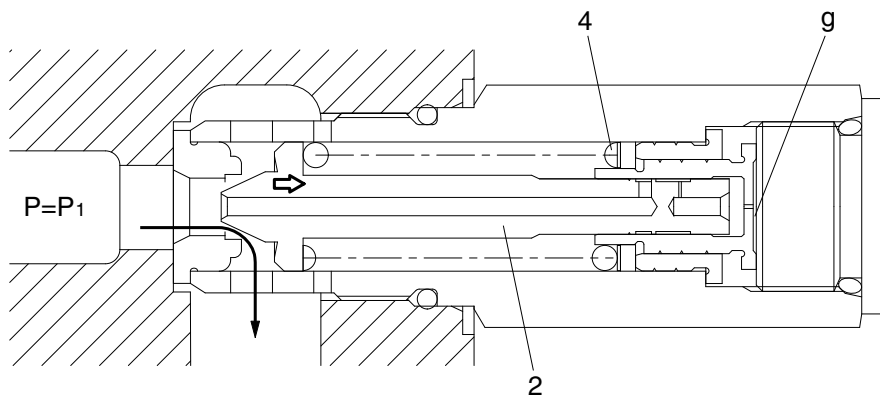

235ZF2SM27

- ③ The oil flow chamber g via orifice m and n. When the pressure of chamber g reaches the preset force (F_{sp}) of spring (4), the piston (7) moves left and stop the piston (7) hits the bottom of bushing (8).

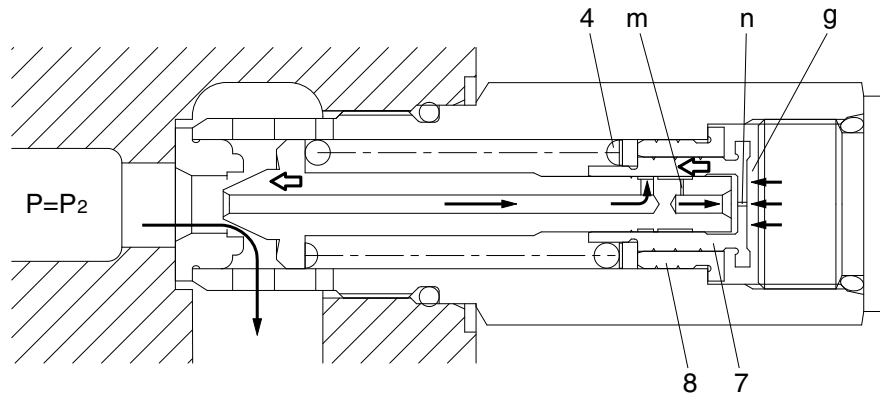

235ZF2SM28

- ④ When piston (7) hits the bottom of bushing (8), it stops moving to the left any further. As the result, the pressure in chamber (g) equals (P_s).

$$P_s \times A_1 = F_{sp} + P_s \times A_2$$

$$P_s = \frac{F_{sp}}{A_1 - A_2}$$

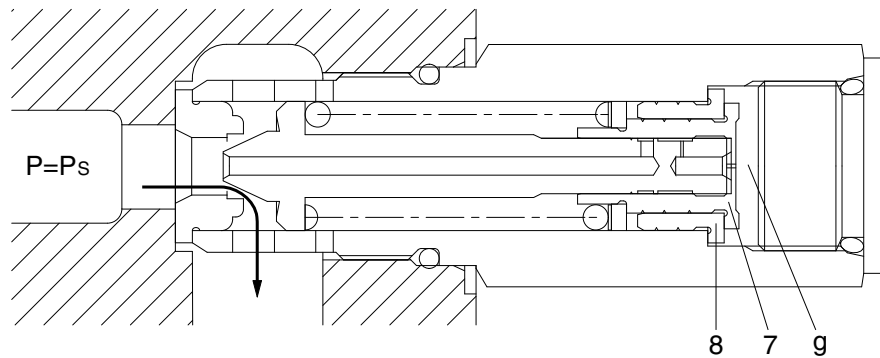

235ZF2SM29

4) BRAKE SYSTEM

(1) Control valve swing brake system

This is the brake system to stop the swing motion of the excavator during operation.

In this system, the hydraulic circuit is throttled by the swing control valve, and the resistance created by this throttling works as a brake force to slow down the swing motion.

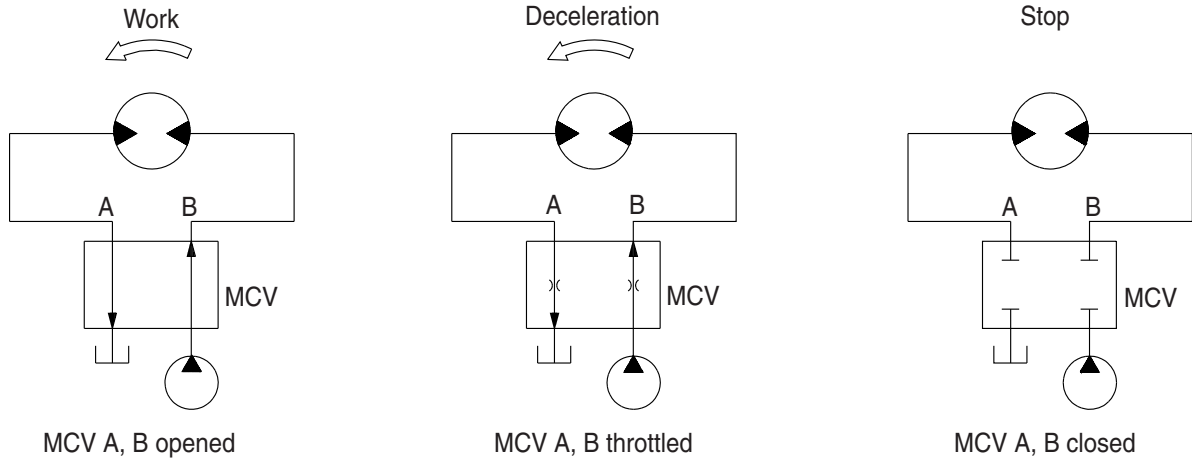

2-48(1)

(2) Mechanical swing parking brake system

This is function as a parking brake only when the swing control lever and arm in control lever are not operated.

① Brake assembly

Circumferential rotation of separate plate (14) is constrained by the groove located at casing (1). When housing is pressed down by brake spring (16) through friction plate (13), separate plate (14) and parking piston (15), friction force occurs there.

Cylinder block (8) is constrained by this friction force and brake acts, while brake releases when hydraulic force exceeds spring force.

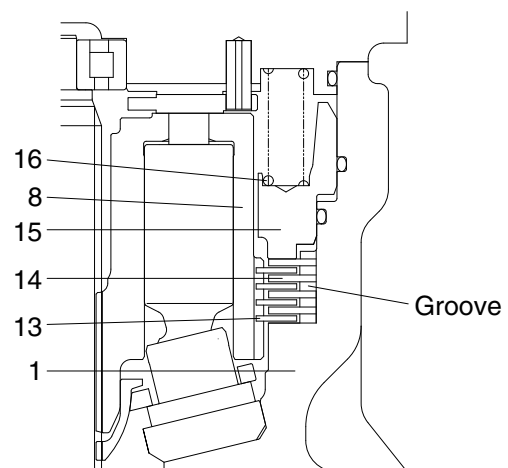

235ZF2SM35

1	Casing	14	Separate plate
8	Cylinder block	15	Parking piston
13	Friction plate	16	Brake spring

② **Operating principle**

a. When one of the RCV lever (1) is set to the operation position, the each spool is shifted to left or right and the pilot oil flow is blocked.

The solenoid valve (5) is shifted to swing position, so pilot pump charged oil (P3) goes to the chamber G through port PG.

This pressure is applied to move the parking piston (15) to the upward against the force of the brake spring (16). Thus, it releases the brake force.

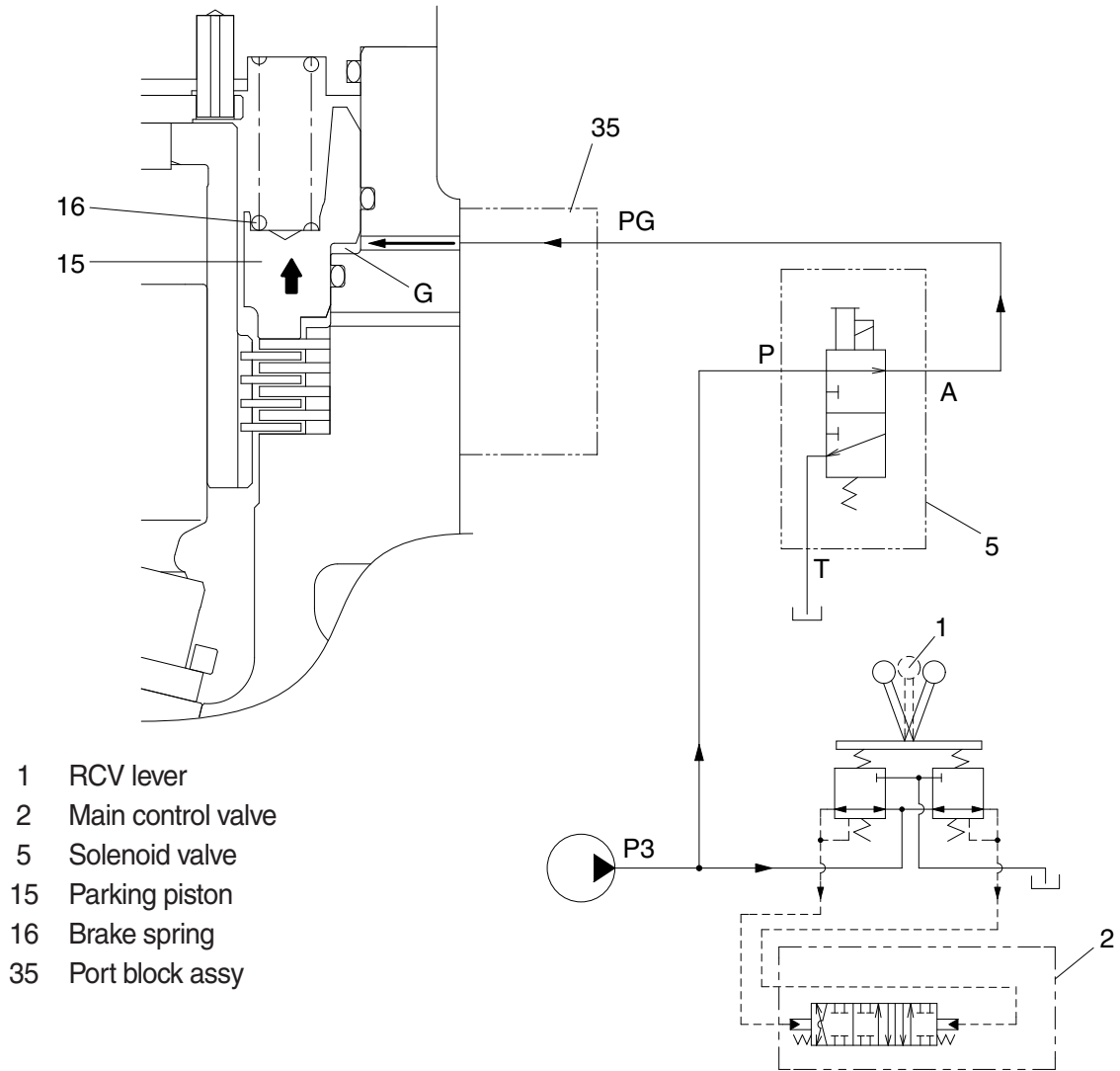

235A2SM36

- b. When all of the RCV lever (1) are set the neutral position, the solenoid valve (5) is returned to swing stop position.
 Then, the parking piston (15) is moved lower by spring force and the return oil from the chamber G flows back to tank port.
 At this time, the brake works.

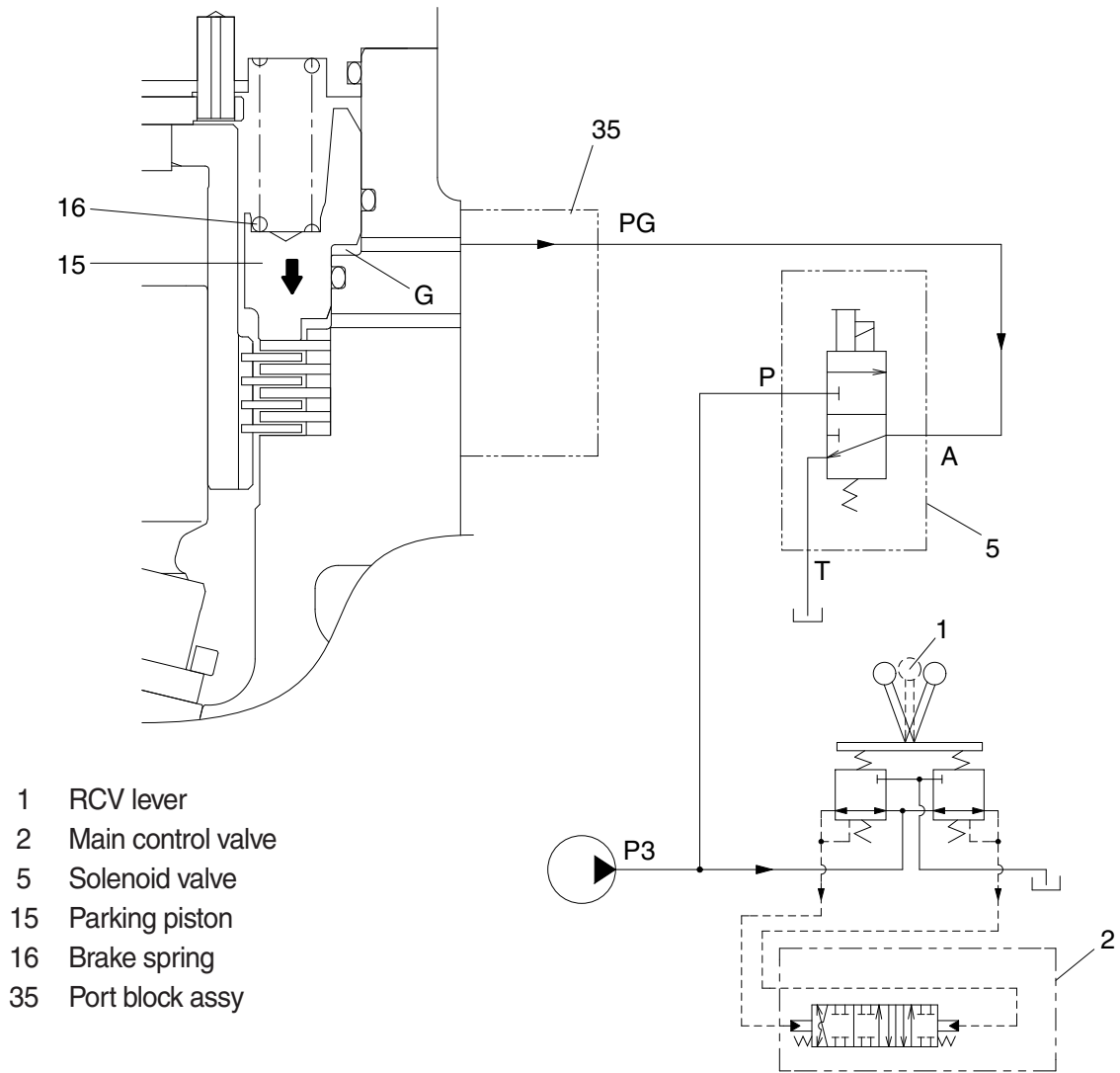

235A2SM37

GROUP 4 TRAVEL DEVICE

1. CONSTRUCTION

Travel device consists travel motor and gear box.

Travel motor includes brake valve, parking brake and high/low speed changeover mechanism.

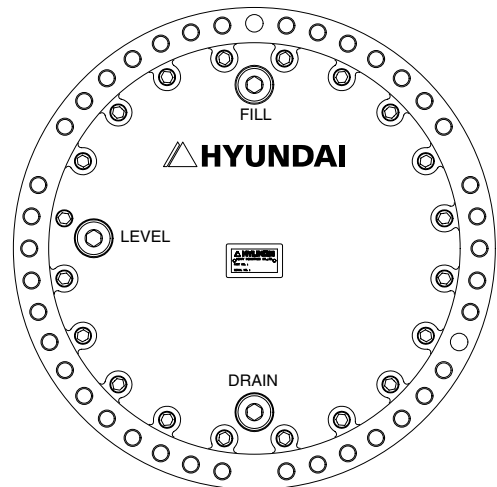
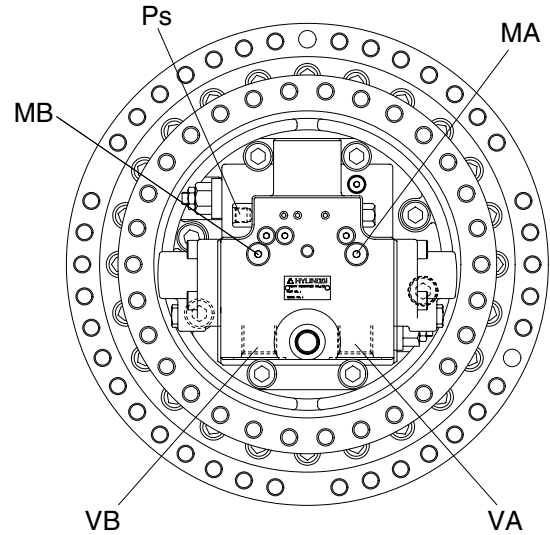
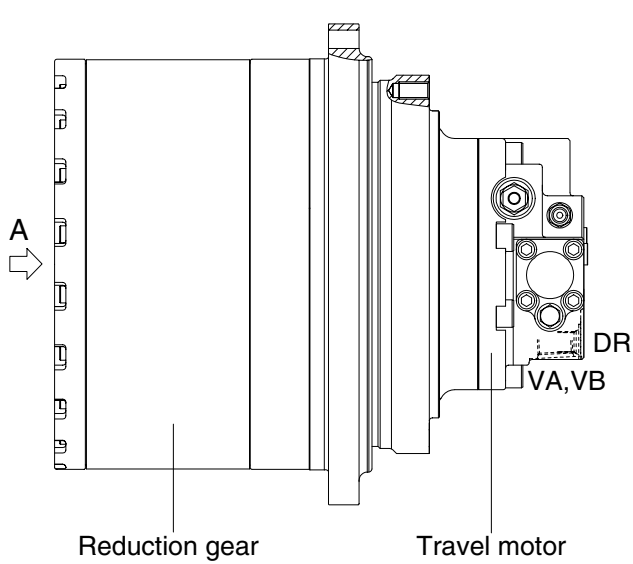

VIEW A

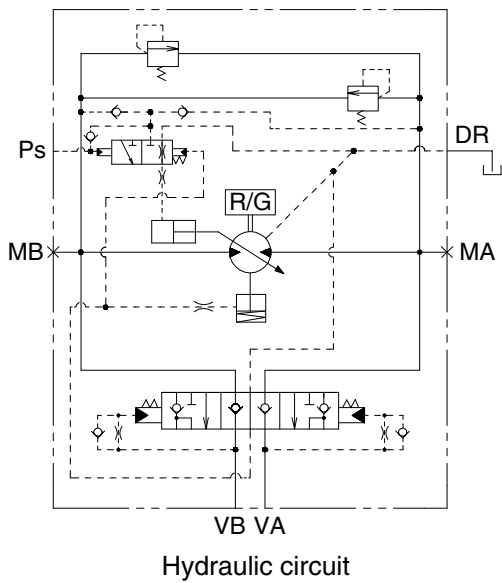

235ZF2TM01

Port	Port name	Port size
VA, VB	Valve port	PF 1
Ps	Pilot port	PF 1/4
DR	Drain port	PF 1/2
MA, MB	Gauge port	PF 1/4

2. SPECIFICATION

1) TRAVEL MOTOR

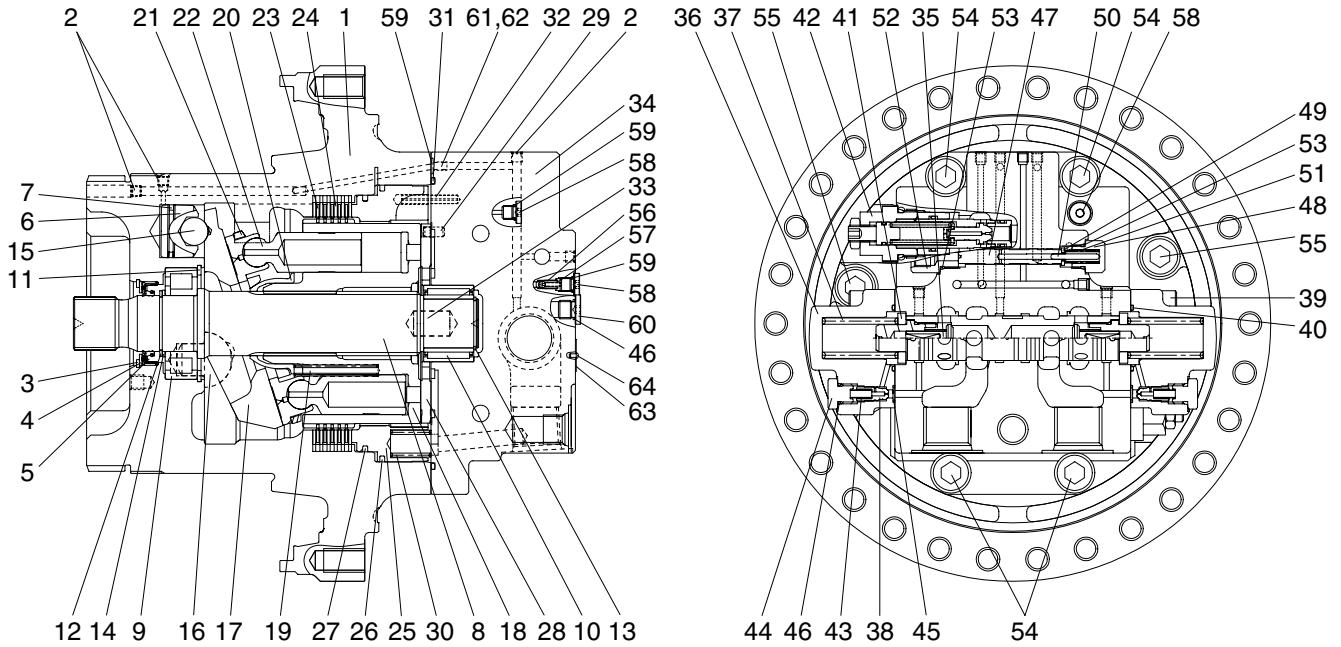

1	Casing	23	Friction plate	44	Plug
2	Plug	24	Separated plate	45	O-ring
3	Oil seal	25	Parking piston	46	O-ring
4	Thrust plate	26	D-ring	47	Spool kit
5	Retaining ring	27	D-ring	48	Plug
6	Swash piston	28	Valve plate	49	Spring seat
7	Piston seal	29	Parallel pin	50	Parallel pin
8	Shaft	30	Brake spring	51	Spring
9	Cylinder roller bearing	31	O-ring	52	Connector
10	Needle bearing	32	Spring pin	53	O-ring
11	Retaining ring	33	Parallel pin	54	Hexagon socket head bolt
12	Retaining ring	34	Rear cover	55	Hexagon socket head bolt
13	Retaining ring	35	Main spool kit	56	Check valve
14	Thrust plate	36	Spool cover	57	Spring
15	Steel ball	37	Spring	58	Plug
16	Swash pivot	38	Restrictor	59	O-ring
17	Swash plate	39	Hexagon socket head bolt	60	Plug
18	Cylinder block	40	O-ring	61	Restrictor
19	Spring	41	Spring seat	62	Restrictor
20	Ball guide	42	Relief valve assy	63	Name plate
21	Set plate	43	Spring	64	Rivet
22	Piston assy				

220L2TM02

2) TRAVEL REDUCTION GEAR

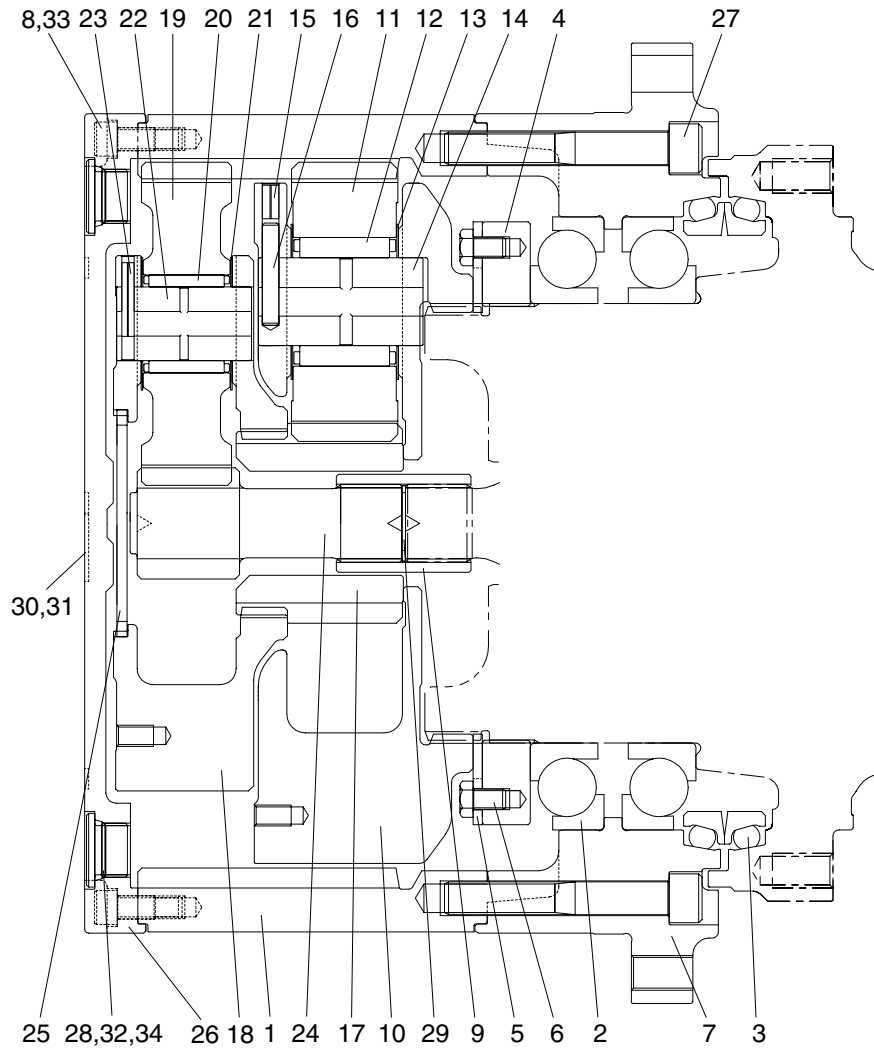

235SA2TM22

1	Ring gear	13	Thrust washer	25	Thrust plate
2	Ball bearing	14	Carrier pin 2	26	Cover
3	Floating seal assy	15	Spring pin	27	Hexagon socket head bolt
4	Nut ring	16	Solid pin 2	28	Plug
5	Lock plate	17	Sun gear 2	29	Retaining ring
6	Hexagon bolt	18	Carrier 1	30	Name plate
7	Housing	19	Planetary gear 1	31	Rivet
8	Hexagon socket head bolt	20	Needle bearing	32	O-ring
9	Coupling	21	Thrust washer	33	Rubber cap
10	Carrier 2	22	Carrier pin 1	34	Rubber cap
11	Planetary gear 2	23	Spring pin		
12	Needle bearing	24	Sun gear 1		

3. OPERATION

1) MOTOR

High pressure oil delivered from hydraulic pump is led to inlet port that is provided in the brake valve portion and, through the rear cover (34) and valve plate (28), led to cylinder block (18).

The oil flow and direction of shaft rotation are indicated in table.

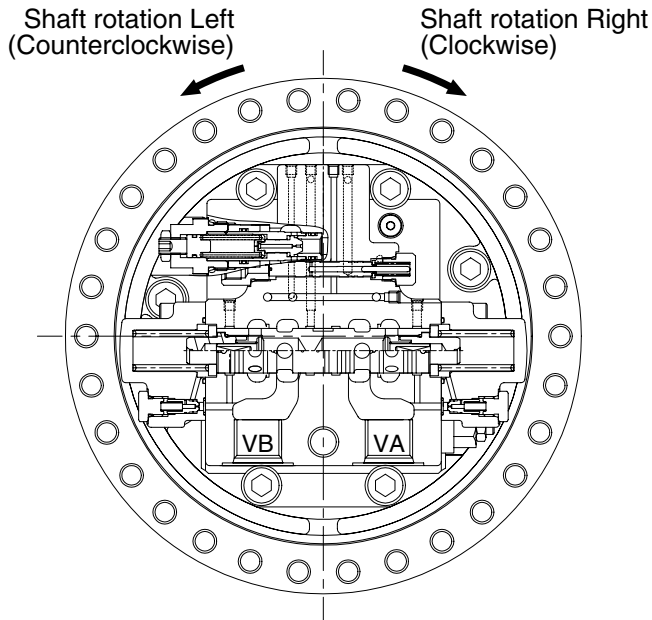

Inlet port	Outlet port	Direction of shaft rotation (viewing from rear cover)
VB	VA	Right (clockwise)
VA	VB	Left (counterclockwise)

25092TM23

As shown in below figure, high pressure oil is supplied to the pistons which are on one side of the line Y-Y that connects upper and lower dead points and produces force F1.

$$F1 = P \times A \quad (P : \text{pressure}, A : \text{area of piston section})$$

The swash plate (17) with inclined angle of α divides this force F1 into thrust force F2 and radial force F31-34.

This radial force is applied to axis Y-Y as turning force and generate drive torque of T.

$$T = r_1 \cdot F31 + r_2 \cdot F32 + r_3 \cdot F33 + r_4 \cdot F34$$

This drive torque is transmitted via cylinder block (18) to driving shaft (8).

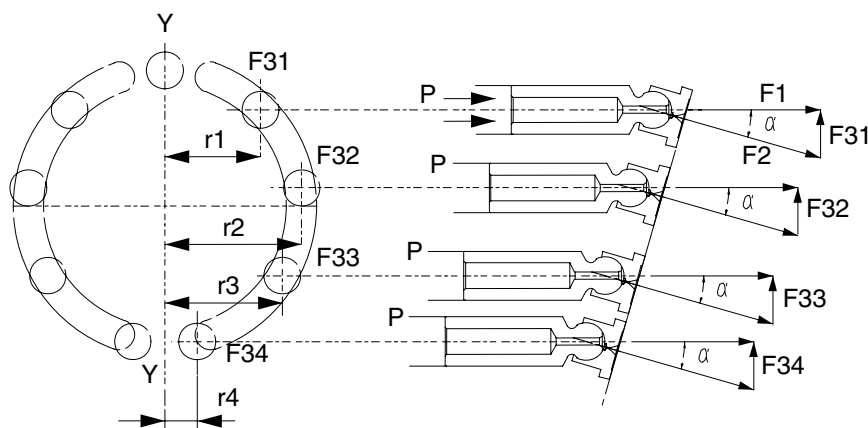

29092TM07

2) PARKING BRAKE

Parking brake is released when high pressure oil selected by the brake valve portion that is connected directly to the rear cover (34), is applied to the parking piston (25).

Otherwise the braking torque is always applied.

This braking torque is generated by the friction between the separated plates (24), inserted into the casing (1), and friction plates (23), coupled to cylinder block (18) by the outer splines.

When no pressure is activated on the parking piston (25), it is pushed by the brake springs (30) and it pushes friction plates (23) and separated plates (24) towards casing (1) and generates the friction force which brakes the rotation of cylinder block (18) and hence the shaft (8).

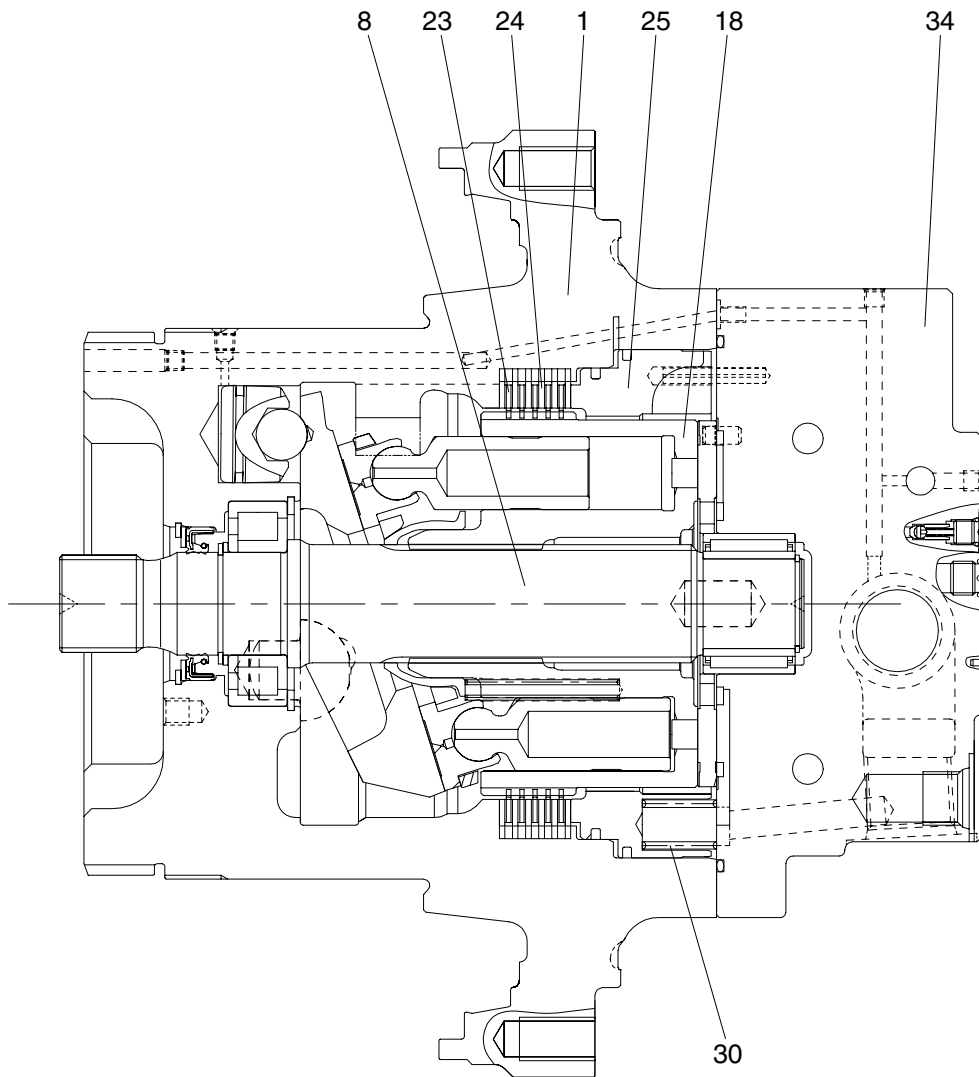

25092TM24

3) CAPACITY CONTROL MECHANISM

Figure typically shows the capacity control mechanism.

When high speed pilot line is charged with the pressure P_A that overcome the spring (51), the spring (51) is compressed and spool (47) shifts to the right to connect the port P and port C.

Then, the highest pressure is selected by the check valve (56) from inlet and outlet pressure of the motor and high speed pilot line pressure and pushes shifter piston (6). As a result, swash plate (17) turns around the line L which connect the two pivots (16) as shown by dotted lines. The turn stops at the stopper (1-1) of casing and swash plate (17) keeps the position.

In this case, the piston stroke become shorter and motor capacity become smaller and motor rotates faster, around 1.60 times, by the same volume of oil.

When no pressure is in the high speed pilot line P_A , spool (35) is pushed back by the spring (51) and pressure that pressed the shifter piston (6) is released to the hydraulic tank through restrictor (61).

Here, nine pistons are there and they equally spaced on the swash plate (17). The force that summed up those of pistons comes to almost the center of the swash plate (17) as shown. Since the pivots (16) are off-set by S from the center, the rotating force of product S and the force moves swash plate (17) to the former position and the speed returns to low.

When the power demand exceeds the engine power, such as in steep slope climbing or turning at high speed mode, the system step down to the low speed automatically. The mechanism is that: pump pressure is led to the port P_B and this pressure activate on pin (50). When the pressure at P_B exceeds predetermined value, spool (47) returns to the left by the counter-pressure against pin (50) and the pressure on the shifter piston (6) through port C is released to the tank and the motor comes to low speed.

When P_B goes down, the spool (47) moves to the right and the speed become high.

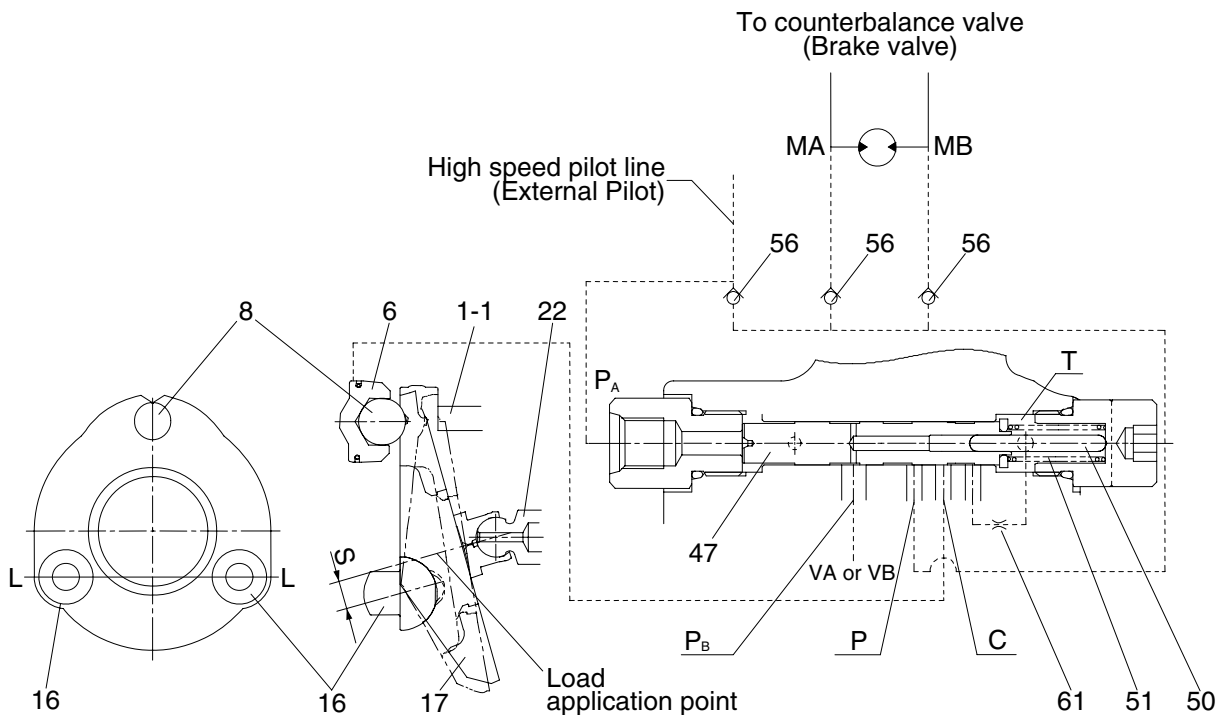

25092TM19

4) OVERLOAD RELIEF VALVE

(1) Structure

This valve is screwed in the motor rear cover (34) and consists of : plug (42-1) that is screwed and fixed in the rear cover (34), poppet (42-10) and supports the poppet seat (42-11), spring (42-4) that is operating relief valve setting pressure and supports the spring seat (42-5), that is inserted in the sleeve (42-6), screw (42-14) that is adjust the spring force, nut (42-15) that fix screw (42-14), piston (42-7) that reduce the shock.

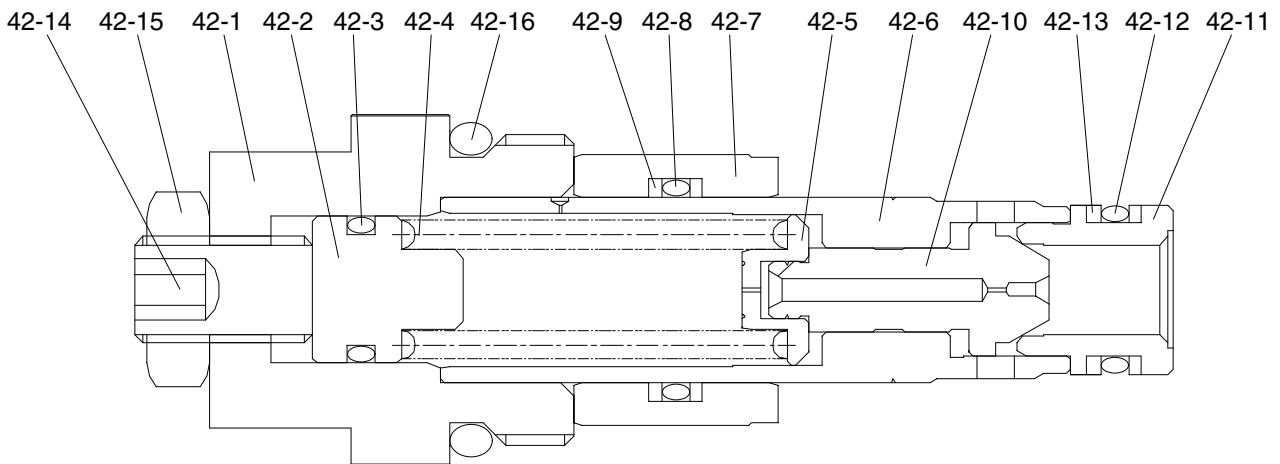

25092TM25

42-1 Plug	42-7 Piston	42-12 O-ring
42-2 Guide	42-8 O-ring	42-13 Back-up ring
42-3 O-ring	42-9 Back-up ring	42-14 Socket screw
42-4 Spring	42-10 Poppet	42-15 Hexagon nut
42-5 Spring seat	42-11 Poppet seat	42-16 O-ring
42-6 Sleeve		

(2) Operation

Two pieces of overload valves are located at cross-over position in the counterbalance circuit of brake valve and have the following functions :

- ① When hydraulic motor starts, keep the driving pressure below predetermined value and while accelerating, bypasses surplus oil to return line.
- ② When stopping the motor, keep the brake pressure, that develops on the outlet side of motor, under the predetermined value to stop the inertial force.
- ③ To accelerate sharply while starting, and to mitigate the braking shock while stopping. For these purposes, the developed pressure is kept comparatively low for a short period, then keep the line pressure as normal value. While the pressure is low, meshing of reduction gears, crawler and sprocket etc. can be smoothly done and the shock are absorbed.

When starting, "A" port pressure of overload valve increases, this pressure is applied to the effective diameter of poppet (42-10) which seats on the poppet seat (42-11) and, at the same time, is delivered, via small hole, to the spring seat (42-5) located inside the sleeve (42-6) and the seat bore pressure increases up to "A" port pressure. The poppet (42-10) opposes to spring (42-4) by the force of the pressure exerted on the area difference between poppet seat's effective diameter and spring seat bore and keep the predetermined pressure.

When hydraulically braking, the piston (42-7) is at the left position by the driving pressure, and when "A" port pressure increases, the pressure is applied also to the piston (42-7) through the small hole in the poppet (42-10) and piston (42-7) moves rightward until it touches the stopper in rear cover. In this while, the poppet (42-10) maintains "A" port pressure at comparatively low against the spring (42-4) force and exhaust oil to "B" port side. After the piston reached to the plug, the valve acts the same as at starting.

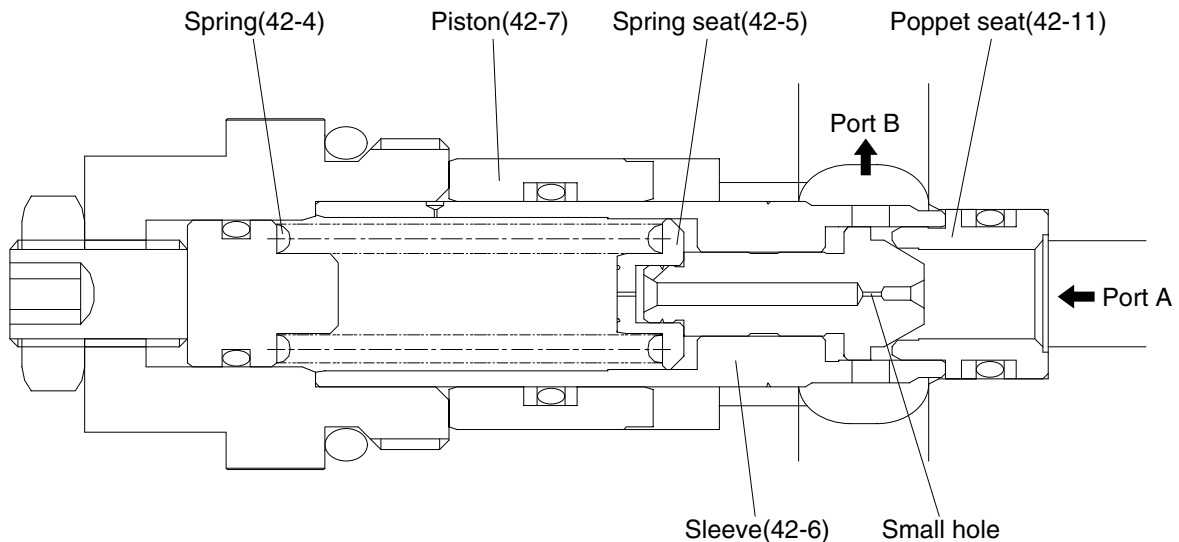

25092TM27

5) BRAKE VALVE

(1) Structure

The brake valve portion mainly consists of the following parts:

① Spool

By shifting the spool (35), the discharged oil from hydraulic motor is automatically shut off or restricted according to the condition and give the effect of holding, accelerating, stopping and counterbalance operations.

(See page 2-76, (2) Operation)

② Check valve (built in the spool)

This valve is located in the oil supplying passage to hydraulic motor, and at the same time functions to lock oil displacement. Therefore, this valve serves as not only a suction valve but also a holding valve for hydraulic motor.

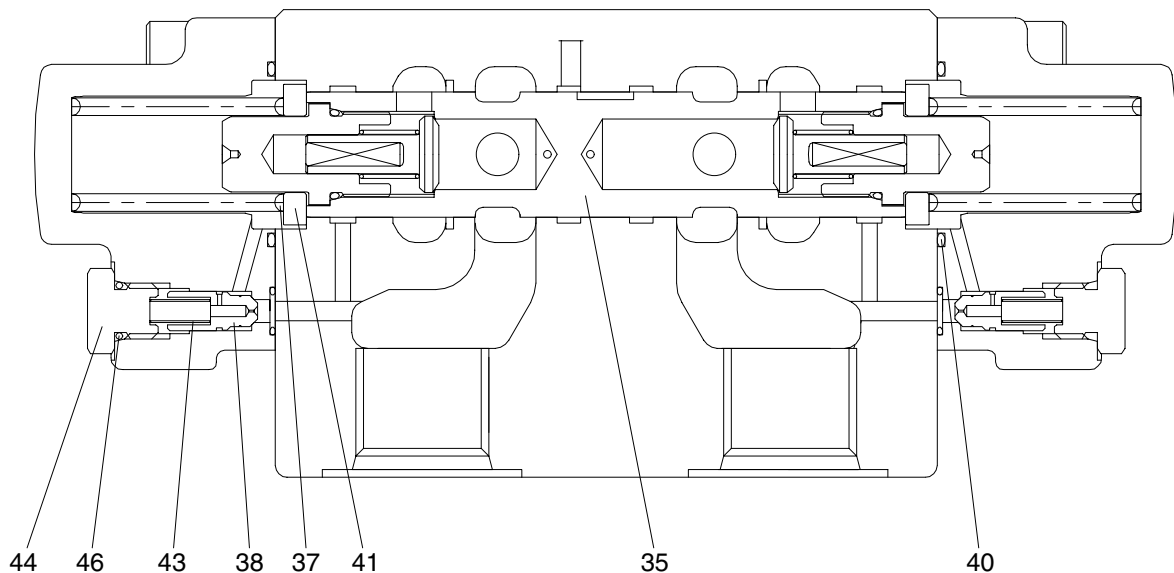

25092TM28

35 Main spool
37 Spring
38 Restrictor

40 O-ring
41 Spring seat
43 Restrictor spring

44 Plug
46 O-ring

(2) Operation

① Holding operation

When the control valve is at neutral position, VA and VB ports are connected to the tank, and the spring (37) located on both spool ends holds the spool (35) at central position.

Therefore, the passages from VA to MA and VB to MB are closed, which result in closing MA and MB ports connected to hydraulic motor.

Since the passage to parking brake is connected to the tank line, the brake cylinder pressure is equal to the tank pressure and the brake is applied by the springs. Thus, the rotation of the motor is mechanically prevented.

If external torque is exerted on the motor shaft, the motor would not rotate as usual by this negative parking brake.

In case the brake should be released for some reason, pressure is built on MA or MB port. But, due to oil leakage inside hydraulic motor or so, high-pressure oil escapes from the closed circuit and motor rotates a bit. So, the cavitation tends to occur in the lower pressure side of the closed circuit. Then, the check valve, built in the spool (35), operates to avoid the cavitation and opens the passage from VA to MA or from VB to MB. Then the oil equivalent to the leakage is sucked from the tank line to the closed circuit.

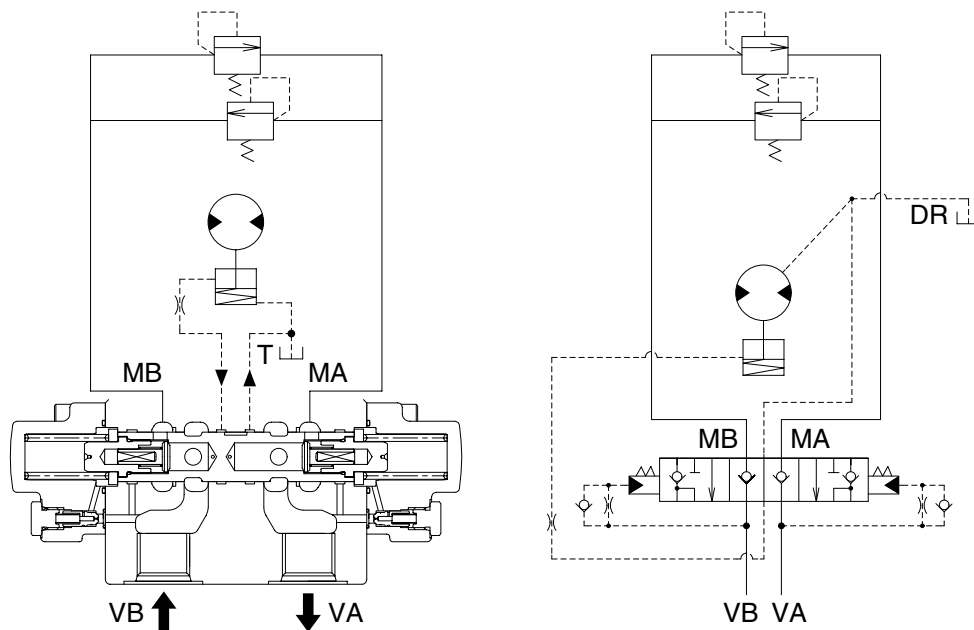

25092TM29

② Accelerating operation

When VA and VB ports are connected respectively to pump and tank by operating the control valve, hydraulic oil from pump is forwarded through VA port to push open the check valve provided inside spool (35), and oil flows to motor via MA port to rotate the motor.

Therefore, the pressure increases and negative brake is released by the pressure supplied from pump. At the same time, the pressure of pilot chamber increases to push and move the spool (35) leftwards, overcoming the spring (37) force. Thus, the return line from MB to VB opens to rotate the motor.

In case inertia load is too big to start rotation, accelerating pressure reaches the set pressure of relief valve and high pressure oil is being relieved while the motor gains the rotational speed.

As the rotational speed goes up, the relieved volume decreases, and finally the motor rotates at a fixed speed.

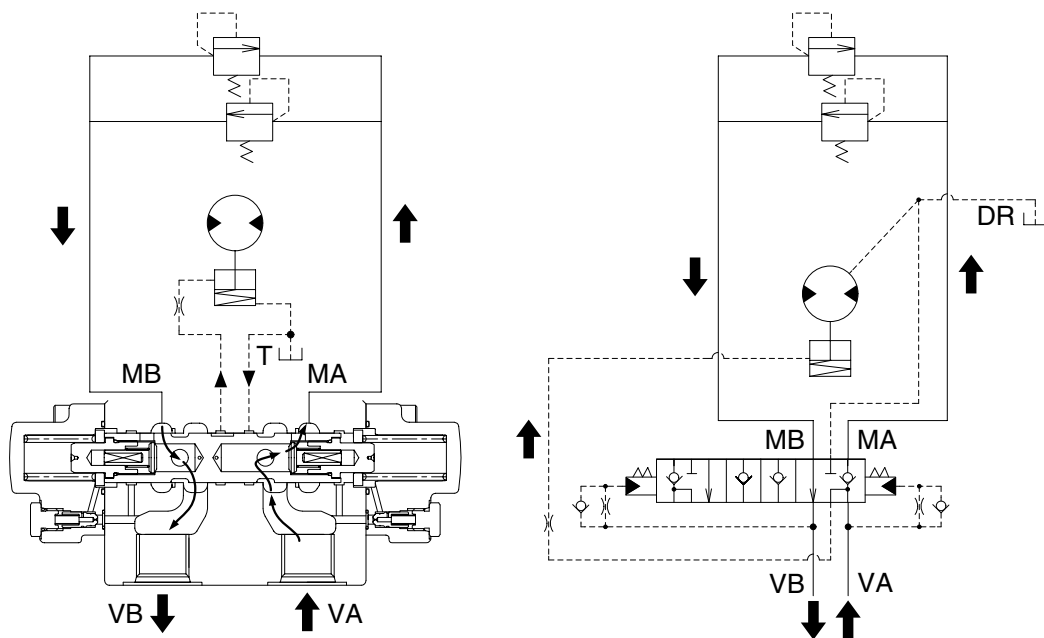

25092TM30

③ Stopping operation

Returning the control valve to neutral position while running the motor, the oil supply is cut off and VA and VB ports are connected to the tank line. Then the pressure of the pilot chamber located on both spool ends become equal, and the spool (35) returns to the neutral position by spring (37) force. Thus, the passage from MA to VA is closed.

Owing to the inertia force of the load, the hydraulic motor tends to continue the rotation. Here, the motor functions as a pump and forwards the oil to MB port but the passage is blocked and MB port pressure increases. Then the relief valve opens to relieve the pressure and rotational speed decelerates and at last the motor stops.

Negative brake release pressure is gradually lowered due to the restrictor and finally the brake works and the motor is mechanically stopped.

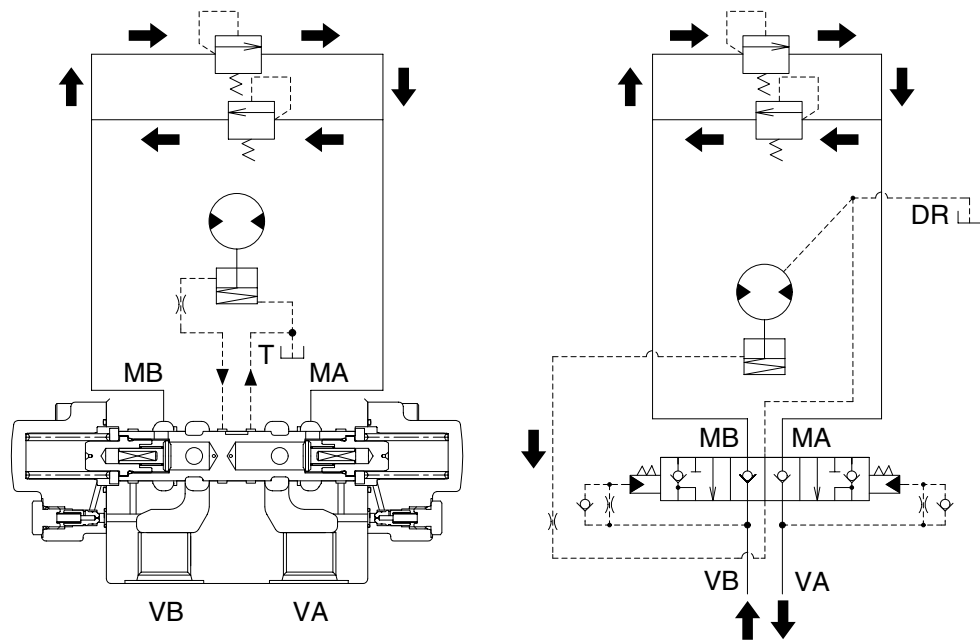

25092TM31

④ Counterbalance operation

Counterbalance operation is required to decelerate slowly the hydraulic motor while absorbing inertia force.

In case the hydraulic oil is gradually decreased from pump to VB port, the drive shaft of hydraulic motor tends to rotate faster than that matched to the volume of oil supply.

Consequently, the pilot chamber pressure on MB to VB side decreases and the spring (37) force moves the spool (35) leftwards towards neutral position.

Therefore, the area of passage from MA to VA becomes smaller and the pressure on MA side rises due to increased resistance in the passage and the motor receives hydraulic braking effect.

If the motor rotates slower than that matched to the volume of supplied oil, the pilot chamber pressure on VB port increases, and spool (35) moves rightwards to enlarge the area of passage from MA to VA. Therefore the braking effect becomes smaller and the rotational speed of motor is controlled to correspond to the volume of supplied oil.

In order to give stable counterbalance operation, the restrictors (38) are set in the pilot chamber to damp the spool (35) movement.

The parking brake is released during pressure adjusting action of the spool (35).

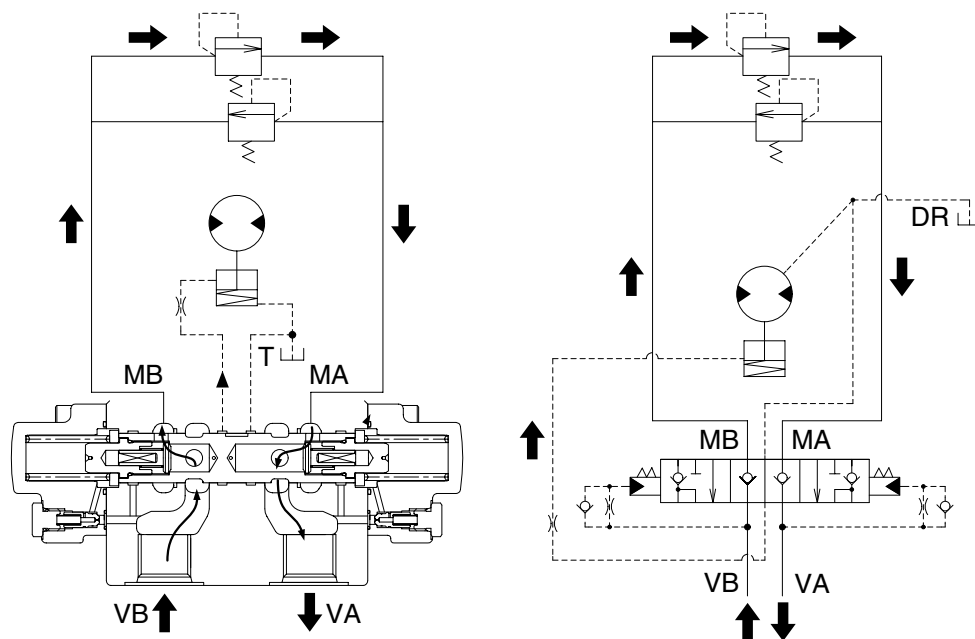

25092TM32

6) REDUCTION GEAR

Reduction unit slows down the rotating speed of motor and converts motor torque to strong rotating force.

This reduction unit utilizes two stages, planetary reduction system.

Planetary reduction system consists of sun gear, planetary gears, (planetary) carriers, and ring gear.

When the sun gear (s) is driven through input shaft, planetary pinions (b), rotating on their center, also move, meshing with fixed ring gear (a), around sun gear (s).

This movement is transferred to carrier (k) and deliver the torque.

This mechanism is called planetary gear mechanism.

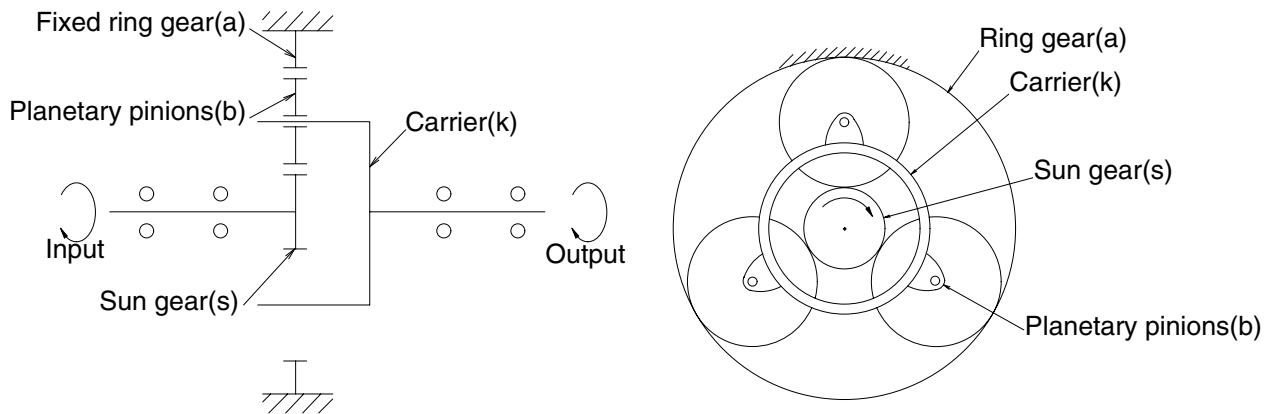

29072TM10

29072TM11

When the sun gear **S1** is driven by input shaft, planetary action occurs among gears **S1**, **a** and **b** and revolution of gear **b** transfers the rotation of carrier **K1** to second sun gear **S2**, and also evokes planetary action between gear **S2**, **a** and **d**.

This time, because carrier **K2** is fixed to frame, gear **d** drives ring gear **a** and then ring gear **a** rotates to drive sprocket.

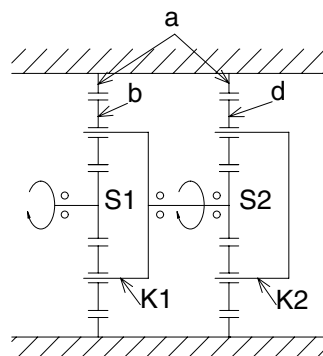

29072TM12

GROUP 5 RCV LEVER

1. STRUCTURE

The casing has the oil inlet port P (primary pressure) and the oil outlet port T (tank). In addition the secondary pressure is taken out through ports 1, 2, 3 and 4 provided at the bottom face.

※ Refer to the parts manual for the types of the RCV lever.

1) TYPE M1, M5, M10

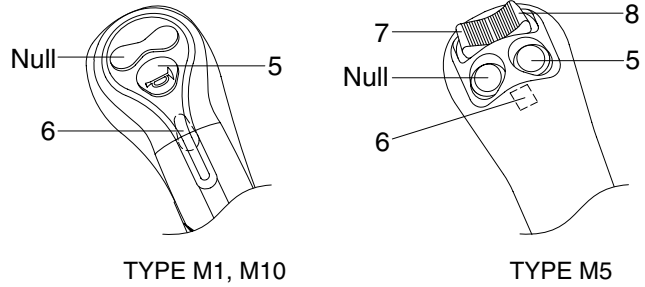
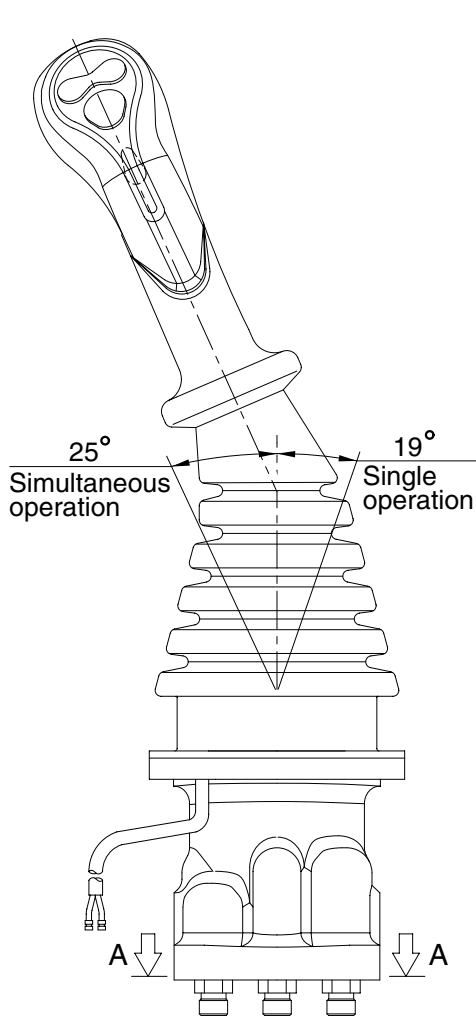

Switches

Type	No.	LH	RH
M1, M10	5	One touch decel	Horn
	6	Power boost	Breaker
M5	5	One touch decel	Horn
	6	Power boost	Null
	7	CCW rotation	Close
	8	CW rotation	Open

※ Number 7 and 8 : Option attachment

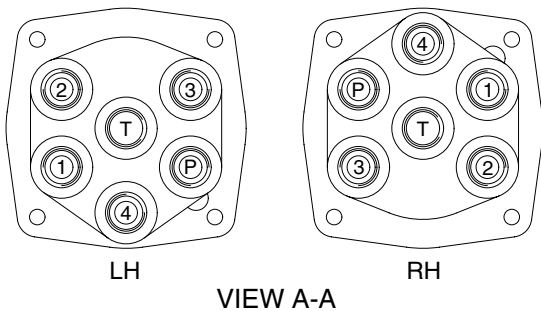
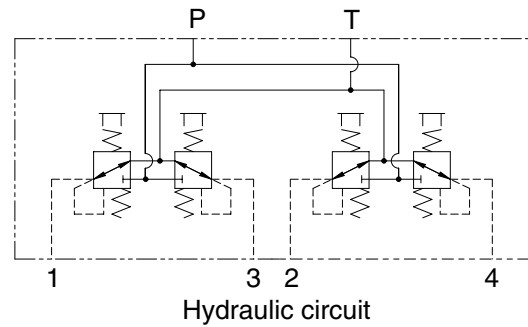

Pilot ports

Port	LH	RH	Port size
P	Pilot oil inlet port	Pilot oil inlet port	PF 3/8
T	Pilot oil return port	Pilot oil return port	
1	Left swing port	Bucket out port	
2	Arm out port	Boom up port	
3	Right swing port	Bucket in port	
4	Arm in port	Boom down port	

235SA2RL01

2) TYPE M2, M4, M9

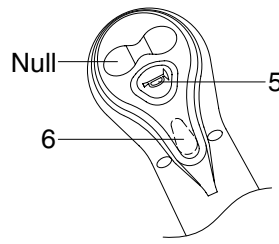
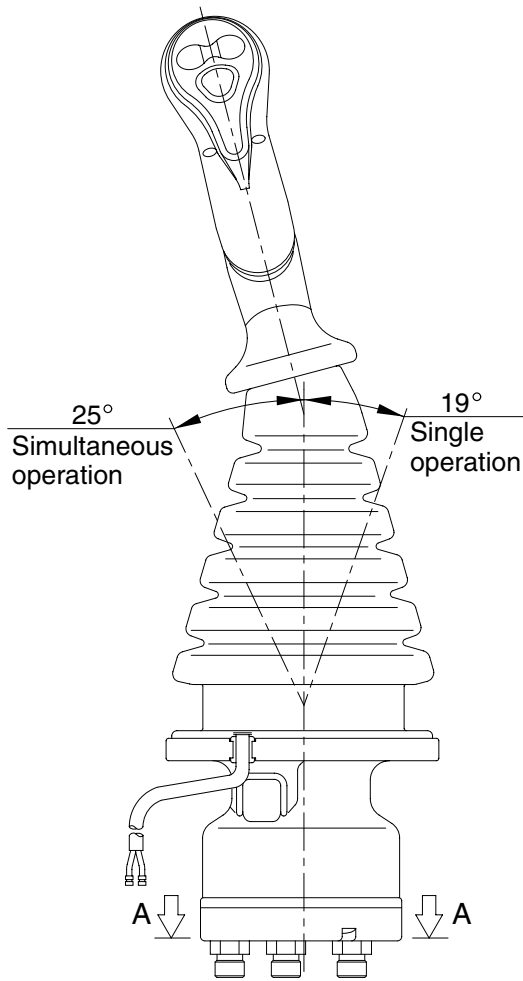

TYPE M2, M9

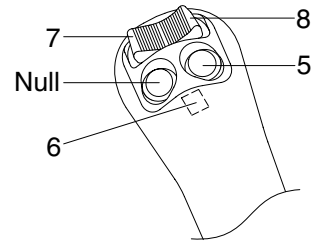

TYPE M4

Switches

Type	No.	LH	RH
M2, M9	5	One touch decel	Horn
	6	Power boost	Breaker
M4	5	One touch decel	Horn
	6	Power boost	Null
	7	CCW rotation	Close
	8	CW rotation	Open

※ Number 7 and 8 : Option attachment

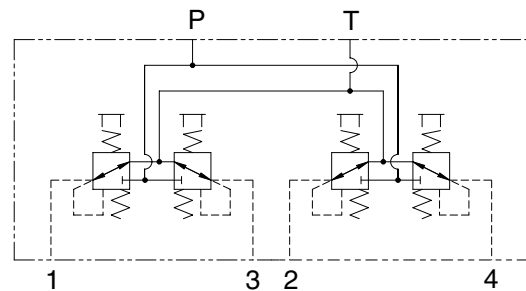

Hydraulic circuit

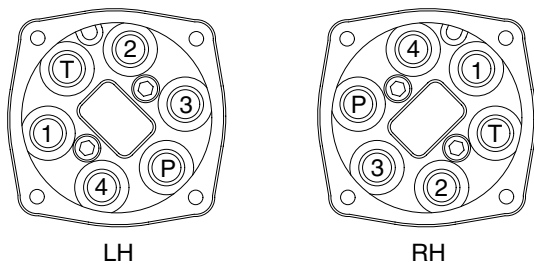

VIEW A-A

Pilot ports

Port	LH	RH	Port size
P	Pilot oil inlet port	Pilot oil inlet port	PF 3/8
T	Pilot oil return port	Pilot oil return port	
1	Left swing port	Bucket out port	
2	Arm out port	Boom up port	
3	Right swing port	Bucket in port	
4	Arm in port	Boom down port	

235SA2RL05

3) CROSS SECTION

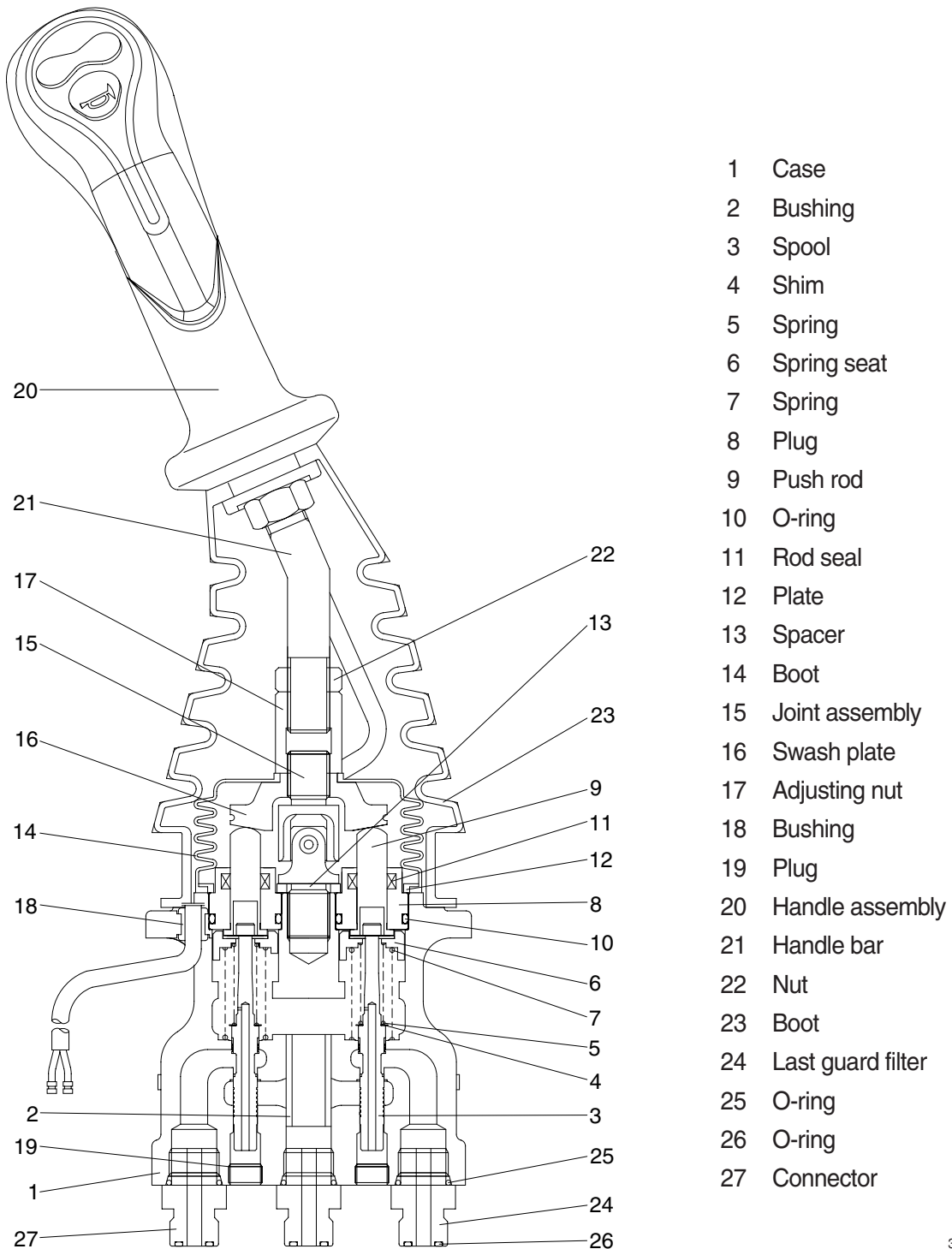

- 1 Case
- 2 Bushing
- 3 Spool
- 4 Shim
- 5 Spring
- 6 Spring seat
- 7 Spring
- 8 Plug
- 9 Push rod
- 10 O-ring
- 11 Rod seal
- 12 Plate
- 13 Spacer
- 14 Boot
- 15 Joint assembly
- 16 Swash plate
- 17 Adjusting nut
- 18 Bushing
- 19 Plug
- 20 Handle assembly
- 21 Handle bar
- 22 Nut
- 23 Boot
- 24 Last guard filter
- 25 O-ring
- 26 O-ring
- 27 Connector

300L2RL06

Item numbers are based on the type M1.

The construction of the pilot valve is shown in the attached cross section drawing. The casing has vertical holes in which reducing valves are assembled.

The pressure reducing section is composed of the spool (3), spring (5) for setting secondary pressure, return spring (7), spring seat (6) and shim (4). The spring for setting the secondary pressure has been generally so preset that the secondary pressure is 5 to 20.5 kgf/cm² (depending on the type). The spool is pushed against the push rod (9) by the return spring.

When the push rod is pushed down by tilting the handle, the spring seat comes down simultaneously and changes setting of the secondary pressure spring.

2. FUNCTIONS

1) FUNDAMENTAL FUNCTIONS

The pilot valve is a valve that controls the spool stroke, direction, etc of a main control valve. This function is carried out by providing the spring at one end of the main control valve spool and applying the output pressure (secondary pressure) of the pilot valve to the other end.

For this function to be carried out satisfactorily, the pilot valve is composed of the following elements.

- (1) Inlet port (P) where oil is supplied from hydraulic pump.
- (2) Output ports (1, 2, 3 & 4) to apply pressure supplied from inlet port to ends of control valve spools.
- (3) Tank port (T) necessary to control the above output pressure.
- (4) Spool to connect output port to inlet port or tank port.
- (5) Mechanical means to control output pressure, including springs that work on the above spools.

2) FUNCTIONS OF MAJOR SECTIONS

Item numbers are based on the type M1.

The functions of the spool (3) are to receive the supply oil pressure from the hydraulic pump at its port P, and to change over oil paths to determine whether the pressure oil of port P is led to output ports 1, 2, 3 & 4 or the output port pressure oil to tank port T.

The spring (5) works on this spool to determine the output pressure.

The change the deflection of this spring, the push rod (9) is inserted and can slide in the plug (8).

For the purpose of changing the displacement of the push rod through the swash plate (16) and adjusting nut (17) are provided the handle assy (20) that can be tilted in any direction around the fulcrum of the universal joint (15) center.

The spring (7) works on the case (1) and spring seat (6) and tries to return the push rod (9) to the zero-displacement position irrespective of the output pressure, securing its resetting to the center position.

This also has the effect of a reaction spring to give appropriate control feeling to the operator.

3) OPERATION

The operation of the pilot valve will be described on the basis of the hydraulic circuit diagram shown below and the attached operation explanation drawing.

The diagram shown below is the typical application example of the pilot valve.

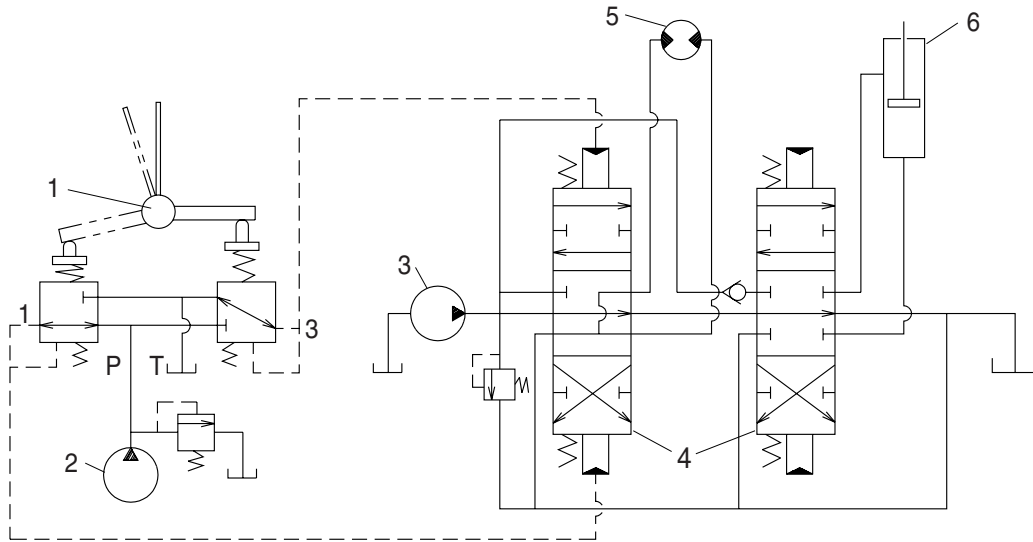

2-70

- 1 Pilot valve
- 2 Pilot pump

- 3 Main pump
- 4 Main control valve

- 5 Hydraulic motor
- 6 Hydraulic cylinder

(1) Case where handle is in neutral position

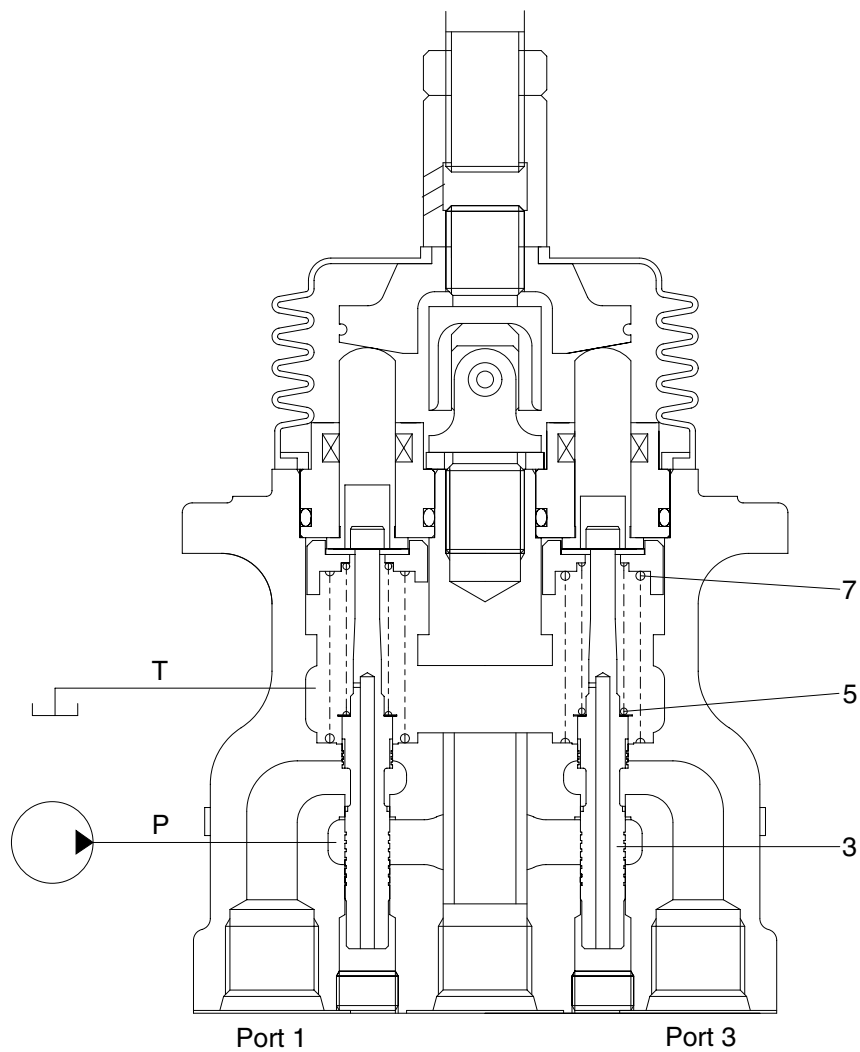

300L2RL03

The force of the spring (5) that determines the output pressure of the pilot valve is not applied to the spool (3). Therefore, the spool is pushed up by the spring (7) to the position of port (1, 3) in the operation explanation drawing. Then, since the output port is connected to tank port T only, the output port pressure becomes equal to tank pressure.

(2) Case where handle is tilted

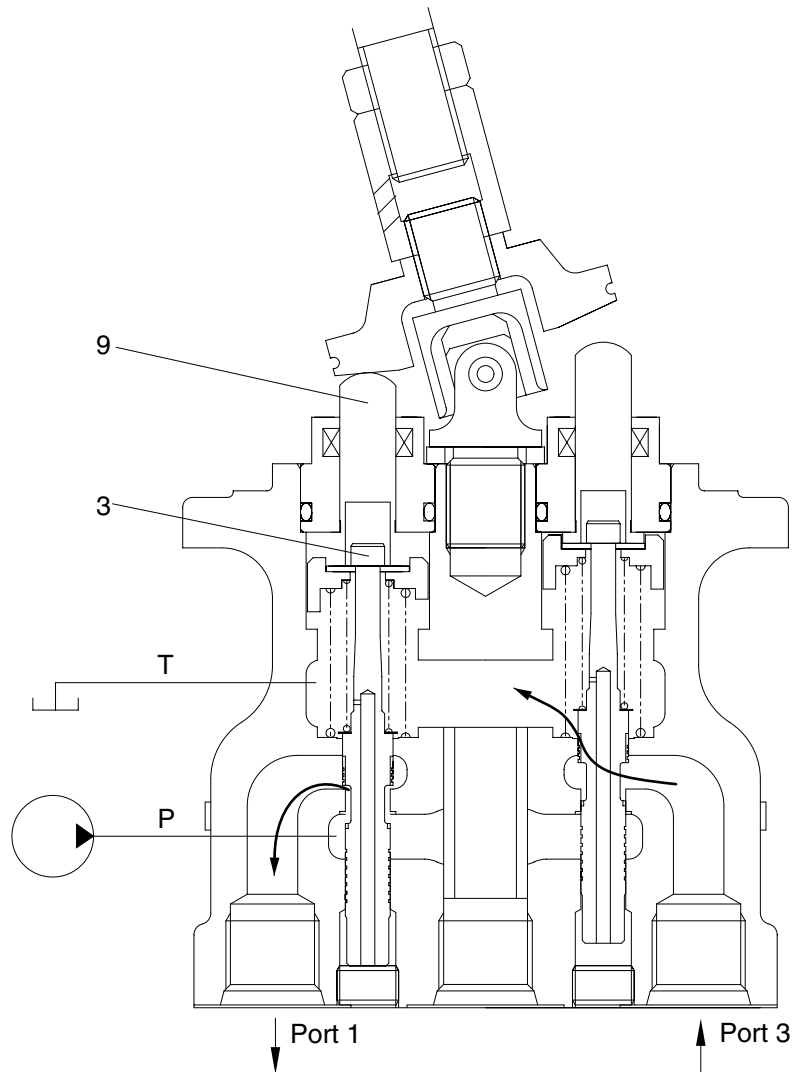

300L2RL04

When the push rod (9) is stroked, the spool (3) moves downwards.

Then port P is connected with port (1) and the oil supplied from the pilot pump flows through port (1) to generate the pressure.

When the pressure at port (1) increases to the value corresponding to the spring force set by tilting the handle, the hydraulic pressure force balances with the spring force. If the pressure at port (1) increases higher than the set pressure, port P is disconnected from port (1) and port T is connected with port (1). If it decreases lower than the set pressure, port P is connected with port (1) and port T is disconnected from port 1.

In this manner the secondary pressure is kept at the constant value.

Besides, in some type, when the handle is tilted more than a certain angle, the upper end of the spool contacts with the inside bottom of the push rod and the output pressure is left to be connected with port P.

GROUP 6 RCV PEDAL

1. STRUCTURE

The casing (spacer) has the oil inlet port P (primary pressure), and the oil outlet port T (tank). In addition the secondary pressure is taken out through ports 1, 2, 3 and 4 provided at the bottom face.

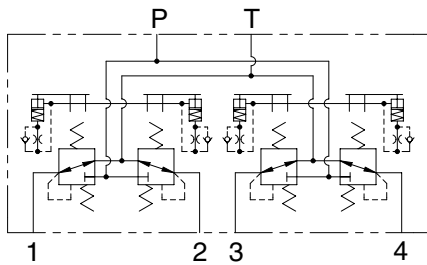
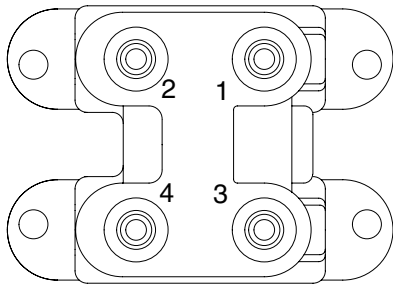
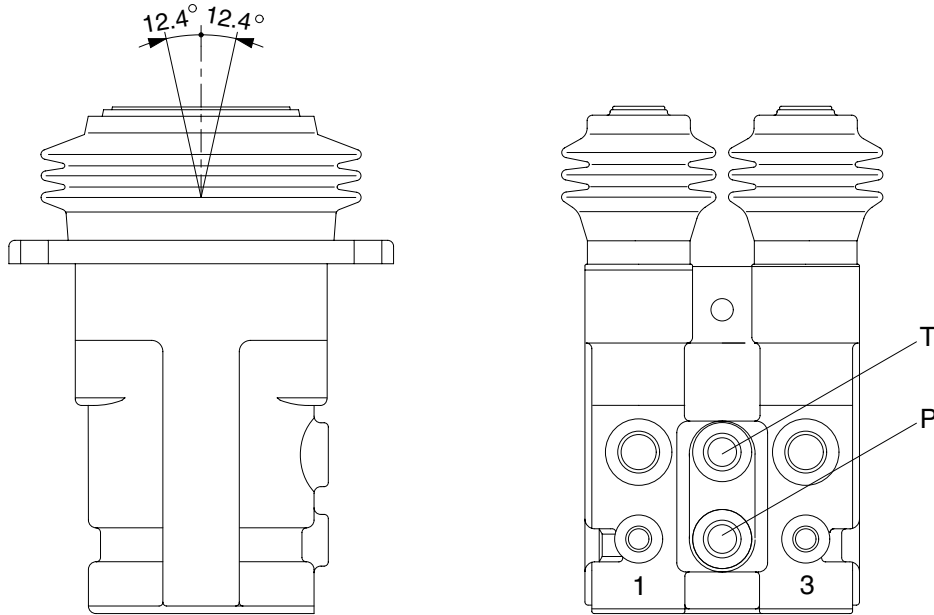

Hydraulic circuit

Port	Port	Port size
P	Pilot oil inlet port	PF 1/4
T	Pilot oil return port	
1	Travel (LH, Forward)	
2	Travel (LH, Backward)	
3	Travel (RH, Forward)	
4	Travel (RH, Backward)	

130ZF2RP01

CROSS SECTION

The construction of the RCV pedal is shown in the below drawing. The casing has vertical holes in which reducing valves are assembled.

The pressure reducing section is composed of the spool (7), spring (5) for setting secondary pressure, return spring (9), stopper (8), and spring seat (6). The spring for setting the secondary pressure has been generally so preset that the secondary pressure is 6.3 ± 1 to 24.9 ± 1.5 kgf/cm² (depending on the type). The spool is pushed against the push rod (13) by the return spring.

When the push rod is pushed down by tilting pedal, the spring seat comes down simultaneously and changes setting of the secondary pressure spring.

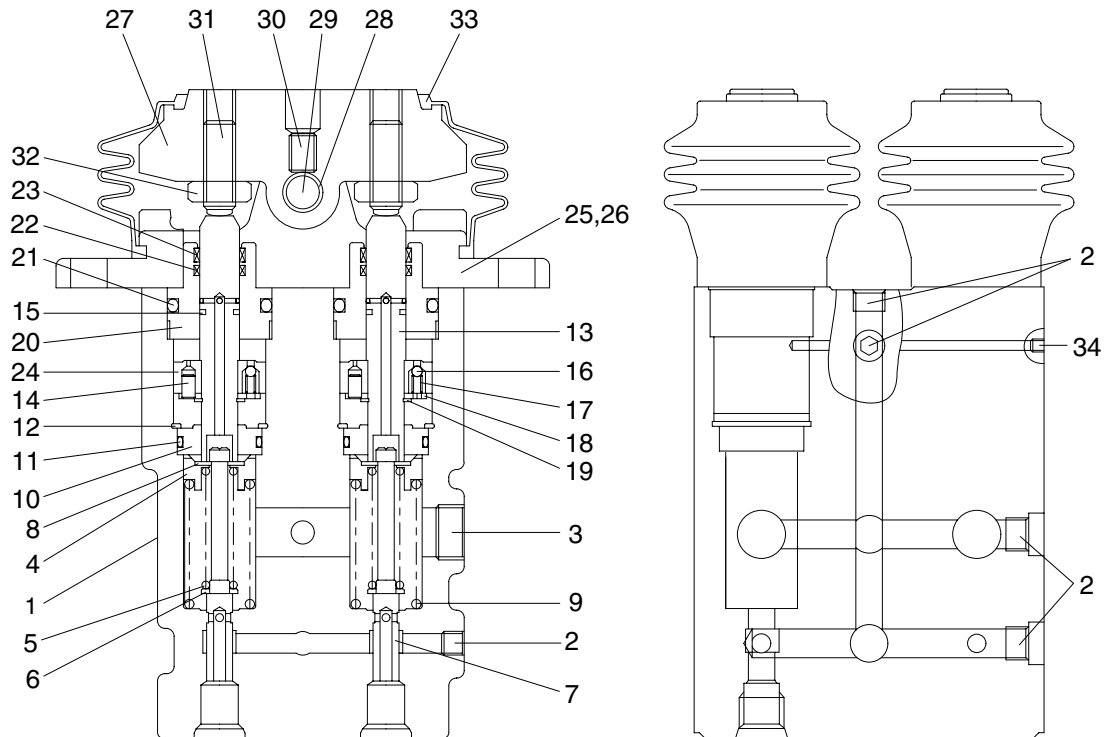

1	Body	13	Push rod	25	Cover
2	Plug	14	Spring pin	26	Socket bolt
3	Plug	15	Seal	27	Cam
4	Spring seat	16	Steel ball	28	Bushing
5	Spring	17	Spring	29	Cam shaft
6	Spring seat	18	Plate	30	Set screw
7	Spool	19	Snap ring	31	Set screw
8	Stopper	20	Plug	32	Hex nut
9	Spring	21	O-ring	33	Bellows
10	Rod guide	22	Rod seal	34	Expand
11	O-ring	23	Dust seal	35	Name plate
12	Snap ring	24	Piston		

130ZF2RP02

2. FUNCTION

1) FUNDAMENTAL FUNCTIONS

The pilot valve is a valve controls the spool stroke, direction, etc of a main control valve. This function is carried out by providing the spring at one end of the main control valve spool and applying the output pressure (secondary pressure) of the pilot valve to the other end.

For this function to be carried out satisfactorily, the pilot valve is composed of the following elements.

- (1) Inlet port (P) where oil is supplied from hydraulic pump.
- (2) Output port (1, 2, 3 & 4) to apply pressure supplied from inlet port to ends of control valve spools.
- (3) Tank port (T) necessary to control the above output pressure.
- (4) Spool to connect output port to inlet port tank port.
- (5) Mechanical means to control output pressure, including springs that work on the above spools.

2) FUNCTIONS OF MAJOR SECTIONS

The functions of the spool (8) are to receive the supply oil pressure from the hydraulic pump at its port P, and to change over oil paths to determine whether the pressure oil of port P is led to output ports 1, 2, 3 & 4 or the output spool to determine the output pressure.

The spring (6) works on this spool to determine the output pressure.

The change the deflection of this spring, the push rod (13) is inserted and can slide in the plug (20). For the purpose of changing th displacement of the push rod through the cam (27) and adjusting nut (32) are provided the pedal that can be tilted in any direction around the fulcrum of the cam (27) center.

The spring (9) works on the body (1) and spring seat (6) and tries to return the push rod (13) to the zero-displacement position irrespective of the output pressure, securing its resetting to the center position.

This also has the effect of a reaction spring to give appropriate control feeling to the operator.

3) OPERATION

The operation of the pilot valve will be described on the basis of the hydraulic circuit diagram shown below and the attached operation explanation drawing.

The diagram shown below is the typical application example of the pilot valve.

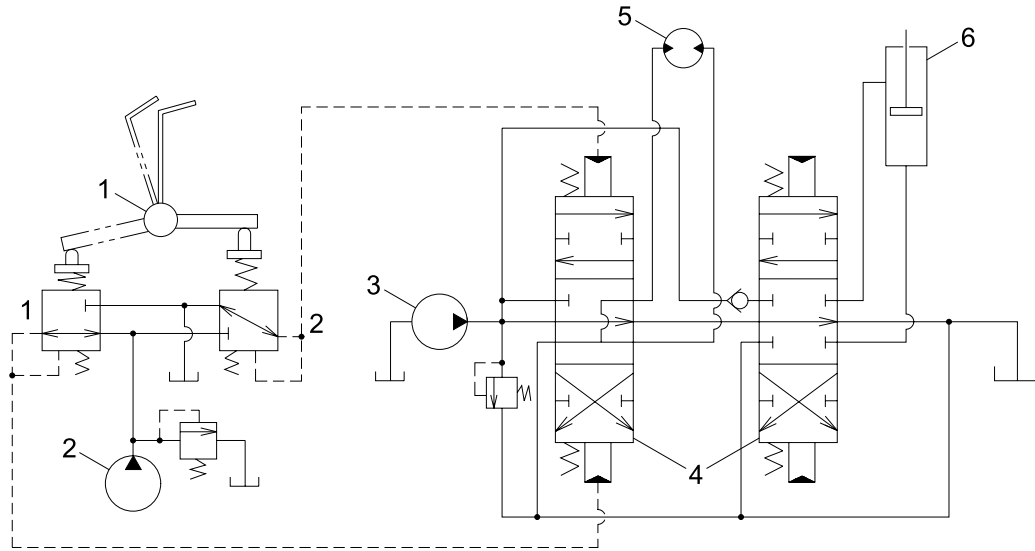

36072SF01

1 Pilot valve
2 Pilot pump

3 Main pump
4 Main control valve

5 Hydraulic motor
6 Hydraulic cylinder

(1) Case where pedal is in neutral position

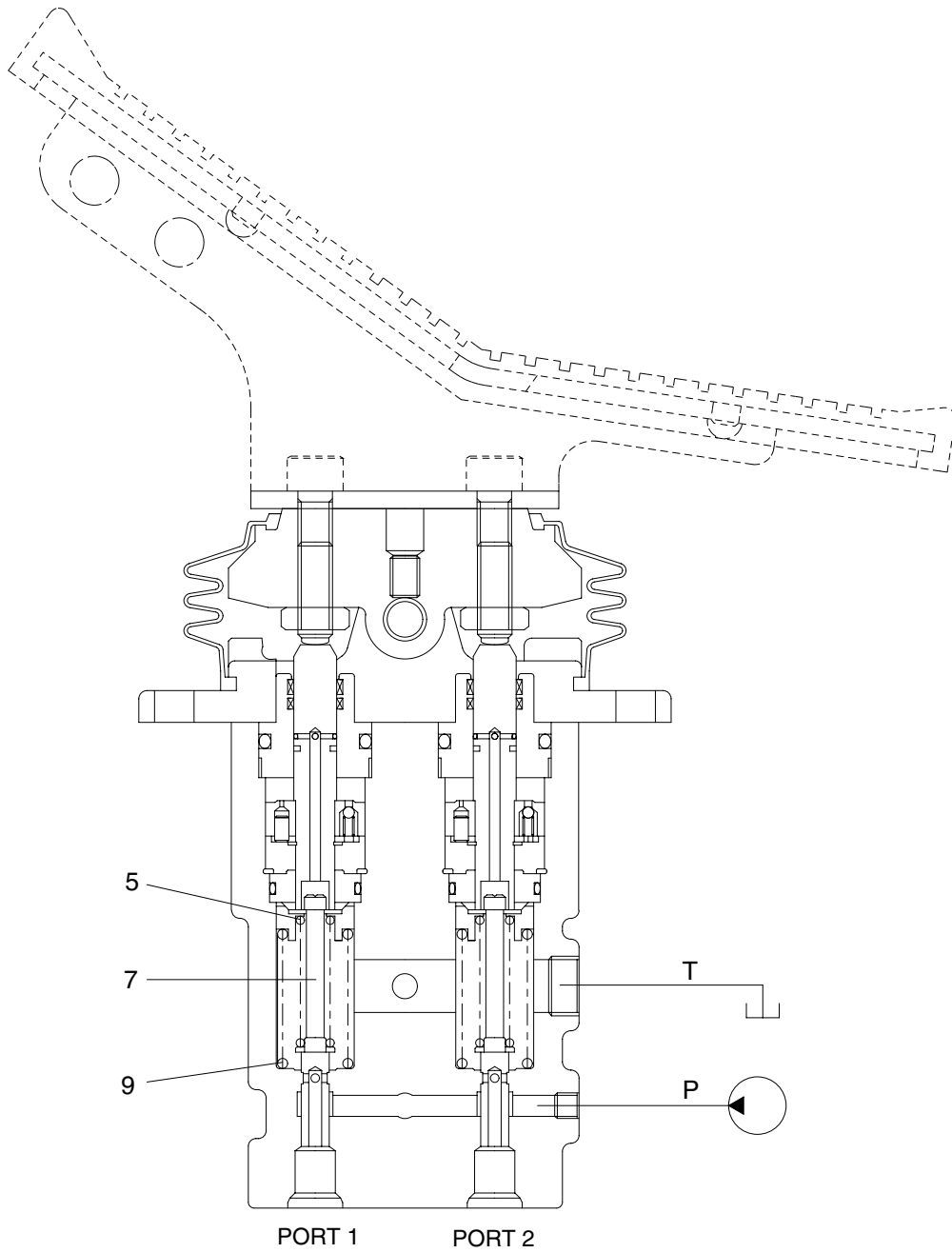

220SA2RP03

The force of the spring (5) that determines the output pressure of the pilot valve is not applied to the spool (7). Therefore, the spool is pushed up by the spring (9) to the position of port 1 and 2. Then, since the output port is connected to tank port T only, the output port pressure becomes equal to tank pressure.

(2) Case where pedal is tilted

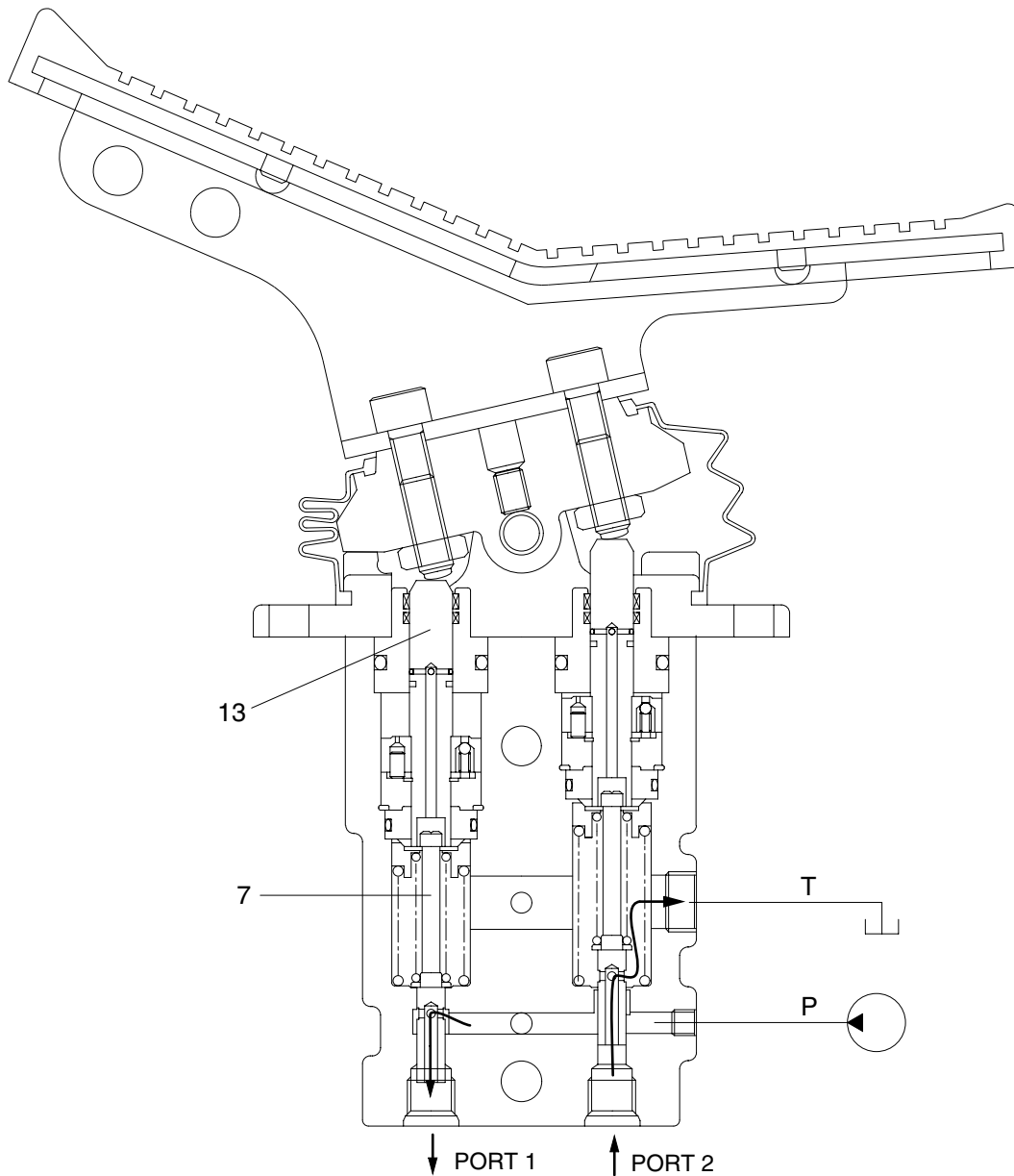

220SA2RP04

When the push rod (13) is stroked, the spool (7) moves downwards.

Then port P is connected with port 1, and the oil supplied from the pilot pump flows through port 1 to generate the pressure.

When the pressure at port 1 increases to the value corresponding to the spring force set by tilting the handle, the hydraulic pressure force balances with the spring force. If the pressure at port 1 increases higher than the set pressure, port P is disconnected from port 1 and port T is connected with port 1. If it decreases lower than the set pressure, port P is connected with port 1 and port T is disconnected from port 1.

In this manner the secondary pressure is kept at the constant value.

Besides, in some type, when the handle is tilted more than a certain angle, the upper end of the spool contacts with inside bottom of the push rod and the output pressure is left to be connected with port P.