

SECTION 8 DISASSEMBLY AND ASSEMBLY

Group 1	Precaution	8-1
Group 2	Tightening Torque	8-4
Group 3	Pump Device	8-7
Group 4	Main Control Valve	8-36
Group 5	Swing Device	8-50
Group 6	Travel Device	8-81
Group 7	RCV Lever	8-113
Group 8	Turning Joint	8-127
Group 9	Boom, Arm and Bucket Cylinder	8-132
Group 10	Undercarriage	8-151
Group 11	Work Equipment	8-164

SECTION 8 DISASSEMBLY AND ASSEMBLY

GROUP 1 PRECAUTIONS

1. REMOVAL WORK

- 1) Lower the work equipment completely to the ground.
If the coolant contains antifreeze, dispose of it correctly.
- 2) After disconnecting hoses or tubes, cover them or fit blind plugs to prevent dirt or dust from entering.
- 3) When draining oil, prepare a container of adequate size to catch the oil.
- 4) Confirm the match marks showing the installation position, and make match marks in the necessary places before removal to prevent any mistake when assembling.
- 5) To prevent any excessive force from being applied to the wiring, always hold the connectors when disconnecting the connectors.
- 6) Fit wires and hoses with tags to show their installation position to prevent any mistake when installing.
- 7) Check the number and thickness of the shims, and keep in a safe place.
- 8) When raising components, be sure to use lifting equipment of ample strength.
- 9) When using forcing screws to remove any components, tighten the forcing screws alternately.
- 10) Before removing any unit, clean the surrounding area and fit a cover to prevent any dust or dirt from entering after removal.
- 11) When removing hydraulic equipment, first release the remaining pressure inside the hydraulic tank and the hydraulic piping.
- 12) If the part is not under hydraulic pressure, the following corks can be used.

Nominal number	Dimensions		
	D	d	L
06	6	5	8
08	8	6.5	11
10	10	8.5	12
12	12	10	15
14	14	11.5	18
16	16	13.5	20
18	18	15	22
20	20	17	25
22	22	18.5	28
24	24	20	30
27	27	22.5	34

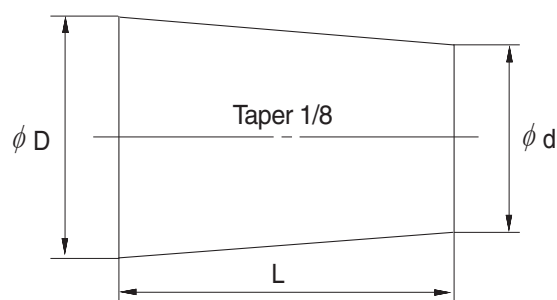

2. INSTALL WORK

- 1) Tighten all bolts and nuts (sleeve nuts) to the specified torque.
- 2) Install the hoses without twisting or interference.
- 3) Replace all gaskets, O-rings, cotter pins, and lock plates with new parts.
- 4) Bend the cotter pin or lock plate securely.
- 5) When coating with adhesive, clean the part and remove all oil and grease, then coat the threaded portion with 2-3 drops of adhesive.
- 6) When coating with gasket sealant, clean the surface and remove all oil and grease, check that there is no dirt or damage, then coat uniformly with gasket sealant.
- 7) Clean all parts, and correct any damage, dents, burrs, or rust.
- 8) Coat rotating parts and sliding parts with engine oil.
- 9) When press fitting parts, coat the surface with antifriction compound (LM-P).
- 10) After installing snap rings, check that the snap ring is fitted securely in the ring groove (Check that the snap ring moves in the direction of rotation).
- 11) When connecting wiring connectors, clean the connector to remove all oil, dirt, or water, then connect securely.
- 12) When using eyebolts, check that there is no deformation or deterioration, and screw them in fully.
- 13) When tightening split flanges, tighten uniformly in turn to prevent excessive tightening on one side.
- 14) When operating the hydraulic cylinders for the first time after repairing and reassembling the hydraulic cylinders, pumps, or other hydraulic equipment or piping, always bleed the air from the hydraulic cylinders as follows:
 - (1) Start the engine and run at low idling.
 - (2) Operate the control lever and actuate the hydraulic cylinder 4-5 times, stopping 100mm before the end of the stroke.
 - (3) Next, operate the piston rod to the end of its stroke to relieve the circuit. (The air bleed valve is actuated to bleed the air.)
 - (4) After completing this operation, raise the engine speed to the normal operating condition.
 - ※ If the hydraulic cylinder has been replaced, carry out this procedure before assembling the rod to the work equipment.
 - ※ Carry out the same operation on machines that have been in storage for a long time after completion of repairs.

3. COMPLETING WORK

- 1) If the coolant has been drained, tighten the drain valve, and add water to the specified level. Run the engine to circulate the water through the system. Then check the water level again.
- 2) If the hydraulic equipment has been removed and installed again, add engine oil to the specified level. Run the engine to circulate the oil through the system. Then check the oil level again.
- 3) If the piping or hydraulic equipment, such as hydraulic cylinders, pumps, or motors, have been removed for repair, always bleed the air from the system after reassembling the parts.
- 4) Add the specified amount of grease (molybdenum disulphied grease) to the work equipment related parts.

GROUP 2 TIGHTENING TORQUE

1. MAJOR COMPONENTS

No.	Descriptions	Bolt size	Torque	
			kgf · m	lbf · ft
1	Engine mounting bolt (engine-bracket)	M12 × 1.75	11.45 ± 1.0	82.8 ± 7.2
2	Engine mounting bolt (bracket-frame, FR)	M20 × 2.5	52.1 ± 5.0	377 ± 36.2
3	Engine mounting bolt (bracket-frame, RR)	M24 × 3.0	90 ± 9.0	651 ± 65.1
4	Radiator mounting bolt	M16 × 2.0	29.7 ± 4.5	215 ± 32.5
5	Coupling mounting socket bolt	M18 × 2.5	32 ± 1.0	231 ± 7.2
6	Fuel tank mounting bolt	M20 × 2.5	46 ± 5.1	333 ± 36.9
7	Main pump housing mounting bolt	M10 × 1.5	6.5 ± 0.7	47 ± 5.1
8	Main pump mounting socket bolt	M20 × 2.5	42 ± 4.5	304 ± 32.5
9	Main control valve mounting nut	M12 × 1.75	12.3 ± 1.3	89.0 ± 9.4
10	Hydraulic oil tank mounting bolt	M20 × 2.5	46 ± 5.1	333 ± 36.9
11	Turning joint mounting bolt, nut	M12 × 1.75	12.3 ± 1.3	89.0 ± 9.4
12	Swing motor mounting bolt	M20 × 2.5	57.9 ± 5.8	419 ± 42
13	Swing bearing upper part mounting bolt	M20 × 2.5	57.9 ± 6.0	419 ± 43.4
13-1	Swing bearing upper part mounting bolt-HW	M24 × 3.0	100 ± 10	723 ± 72.3
14	Swing bearing lower part mounting bolt	M20 × 2.5	57.9 ± 6.0	419 ± 43.4
14-1	Swing bearing lower part mounting bolt-HW	M24 × 3.0	100 ± 10	723 ± 72.3
15	Travel motor mounting bolt	M16 × 2.0	23 ± 2.5	166 ± 18.1
16	Sprocket mounting bolt	M16 × 2.0	29.7 ± 3.0	215 ± 21.7
17	Carrier roller mounting bolt, nut	M16 × 2.0	29.7 ± 3.0	215 ± 21.7
18	Track roller mounting bolt	M20 × 2.5	57.9 ± 6.0	419 ± 43.4
19	Track tension cylinder mounting bolt	M16 × 2.0	29.7 ± 4.5	215 ± 32.5
20	Track shoe mounting bolt, nut	M20 × 1.5	78 ± 8.0	564 ± 57.9
21	Track guard mounting bolt	M20 × 2.5	57.9 ± 8.7	419 ± 62.9
22	Counterweight mounting bolt	M36 × 3.0	337 ± 33	2440 ± 239
23	Cab mounting bolt	M12 × 1.75	12.8 ± 3.0	92.6 ± 21.7
24	Operator's seat mounting bolt	M 8 × 1.25	4.05 ± 0.8	29.3 ± 5.8

※ For tightening torque of engine and hydraulic components, see engine maintenance guide and service manual.

※ H/W : High walker

2. TORQUE CHART

Use following table for unspecified torque.

1) BOLT AND NUT

(1) Coarse thread

Bolt size	8.8T		10.9T		12.9T	
	kgf · m	lbf · ft	kgf · m	lbf · ft	kgf · m	lbf · ft
M 6 × 1.0	0.8 ~ 1.2	5.8 ~ 8.6	1.2 ~ 1.8	8.7 ~ 13.0	1.5 ~ 2.1	10.9 ~ 15.1
M 8 × 1.25	2.0 ~ 3.0	14.5 ~ 21.6	2.8 ~ 4.2	20.3 ~ 30.4	3.4 ~ 5.0	24.6 ~ 36.1
M10 × 1.5	4.0 ~ 6.0	29.0 ~ 43.3	5.6 ~ 8.4	40.5 ~ 60.8	6.8 ~ 10.0	49.2 ~ 72.3
M12 × 1.75	6.8 ~ 10.2	50.0 ~ 73.7	9.6 ~ 14.4	69.5 ~ 104	12.3 ~ 16.5	89.0 ~ 119
M14 × 2.0	10.9 ~ 16.3	78.9 ~ 117	16.3 ~ 21.9	118 ~ 158	19.5 ~ 26.3	141 ~ 190
M16 × 2.0	17.9 ~ 24.1	130 ~ 174	25.1 ~ 33.9	182 ~ 245	30.2 ~ 40.8	141 ~ 295
M18 × 2.5	24.8 ~ 33.4	180 ~ 241	34.8 ~ 47.0	252 ~ 340	41.8 ~ 56.4	302 ~ 407
M20 × 2.5	34.9 ~ 47.1	253 ~ 340	49.1 ~ 66.3	355 ~ 479	58.9 ~ 79.5	426 ~ 575
M22 × 2.5	46.8 ~ 63.2	339 ~ 457	65.8 ~ 88.8	476 ~ 642	78.9 ~ 106	570 ~ 766
M24 × 3.0	60.2 ~ 81.4	436 ~ 588	436 ~ 588	612 ~ 824	102 ~ 137	738 ~ 991
M30 × 3.5	120 ~ 161	868 ~ 1164	168 ~ 227	1216 ~ 1641	202 ~ 272	1461 ~ 1967

(2) Fine thread

Bolt size	8.8T		10.9T		12.9T	
	kgf · m	lbf · ft	kgf · m	lbf · ft	kgf · m	lbf · ft
M 8 × 1.0	2.1 ~ 3.1	15.2 ~ 22.4	3.0 ~ 4.4	21.7 ~ 31.8	3.6 ~ 5.4	26.1 ~ 39.0
M10 × 1.25	4.2 ~ 6.2	30.4 ~ 44.9	5.9 ~ 8.7	42.7 ~ 62.9	7.0 ~ 10.4	50.1 ~ 75.2
M12 × 1.25	7.3 ~ 10.9	52.8 ~ 78.8	10.3 ~ 15.3	74.5 ~ 110	13.1 ~ 17.7	94.8 ~ 128
M14 × 1.5	12.4 ~ 16.6	89.7 ~ 120	17.4 ~ 23.4	126 ~ 169	20.8 ~ 28.0	151 ~ 202
M16 × 1.5	18.7 ~ 25.3	136 ~ 182	26.3 ~ 35.5	191 ~ 256	31.6 ~ 42.6	229 ~ 308
M18 × 1.5	27.1 ~ 36.5	196 ~ 264	38.0 ~ 51.4	275 ~ 371	45.7 ~ 61.7	331 ~ 446
M20 × 1.5	37.7 ~ 50.9	273 ~ 368	53.1 ~ 71.7	384 ~ 518	63.6 ~ 86.0	460 ~ 622
M22 × 1.5	51.2 ~ 69.2	370 ~ 500	72.0 ~ 97.2	521 ~ 703	86.4 ~ 116	625 ~ 839
M24 × 2.0	64.1 ~ 86.5	464 ~ 625	90.1 ~ 121	652 ~ 875	108 ~ 146	782 ~ 1056
M30 × 2.0	129 ~ 174	933 ~ 1258	181 ~ 245	1310 ~ 1772	217 ~ 294	1570 ~ 2126

2) PIPE AND HOSE (FLARE TYPE)

Thread size (PF)	Width across flat (mm)	kgf · m	lbf · ft
1/4"	19	4	28.9
3/8"	22	5	36.2
1/2"	27	9.5	68.7
3/4"	36	18	130.2
1"	41	21	151.9
1-1/4"	50	35	253.2

3) PIPE AND HOSE (ORFS TYPE)

Thread size (UNF)	Width across flat (mm)	kgf · m	lbf · ft
9/16-18	19	4	28.9
11/16-16	22	5	36.2
13/16-16	27	9.5	68.7
1-3/16-12	36	18	130.2
1-7/16-12	41	21	151.9
1-11/16-12	50	35	253.2

4) FITTING

Thread size	Width across flat (mm)	kgf · m	lbf · ft
1/4"	19	4	28.9
3/8"	22	5	36.2
1/2"	27	9.5	68.7
3/4"	36	18	130.2
1"	41	21	151.9
1-1/4"	50	35	253.2

GROUP 3 PUMP DEVICE

1. REMOVAL AND INSTALL

1) REMOVAL

- (1) Lower the work equipment to the ground and stop the engine.
- (2) Operate the control levers and pedals several times to release the remaining pressure in the hydraulic piping
- (3) Loosen the breather slowly to release the pressure inside the hydraulic tank.

▲ Escaping fluid under pressure can penetrate the skin causing serious injury.

- (4) Remove the wirings for the pressure sensors and so on.
- (5) Loosen the drain plug under the hydraulic tank and drain the oil from the hydraulic tank.
 - Hydraulic tank quantity : 160 ℓ
- (6) Remove socket bolts (24) and disconnect pipe (10, 11).

- (7) Disconnect pilot line hoses (2, 3, 4, 5, 6, 7, 8, 9).

- (8) Remove socket bolts (23) and disconnect pump suction tube (1).

※ When pump suction tube is disconnected, the oil inside the piping will flow out, so catch it in oil pan.

- (9) Sling the pump assembly and remove the pump mounting bolts (15).
 - Weight : 146 kg (322 lb)
 - Tightening torque : 42 ± 4.5 kgf·m
(304 ± 32.5 lbf·ft)

※ Pull out the pump assembly from housing. When removing the pump assembly, check that all the hoses have been disconnected.

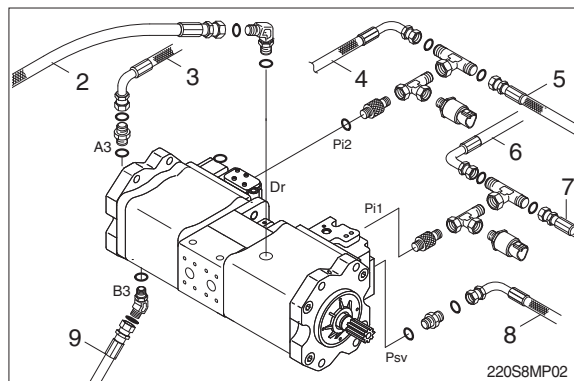
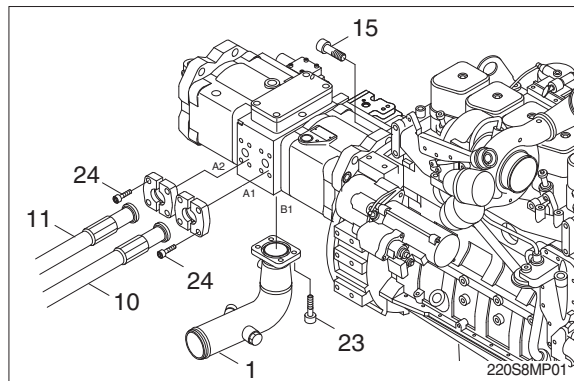

2) INSTALL

- (1) Carry out installation in the reverse order to removal.
- (2) Remove the suction strainer and clean it.
- (3) Replace return filter with new one.
- (4) Remove breather and clean it.
- (5) After adding oil to the hydraulic tank to the specified level.
- (6) Bleed the air from the hydraulic pump.
 - ① Remove the air vent plug (2EA).
 - ② Tighten plug lightly.
 - ③ Start the engine, run at low idling, and check oil come out from plug.
 - ④ Tighten plug.
- (7) Start the engine, run at low idling (3~5 minutes) to circulate the oil through the system.
- (8) Confirm the hydraulic oil level and check the hydraulic oil leak or not.

2. MAIN PUMP (1/3)

1) STRUCTURE

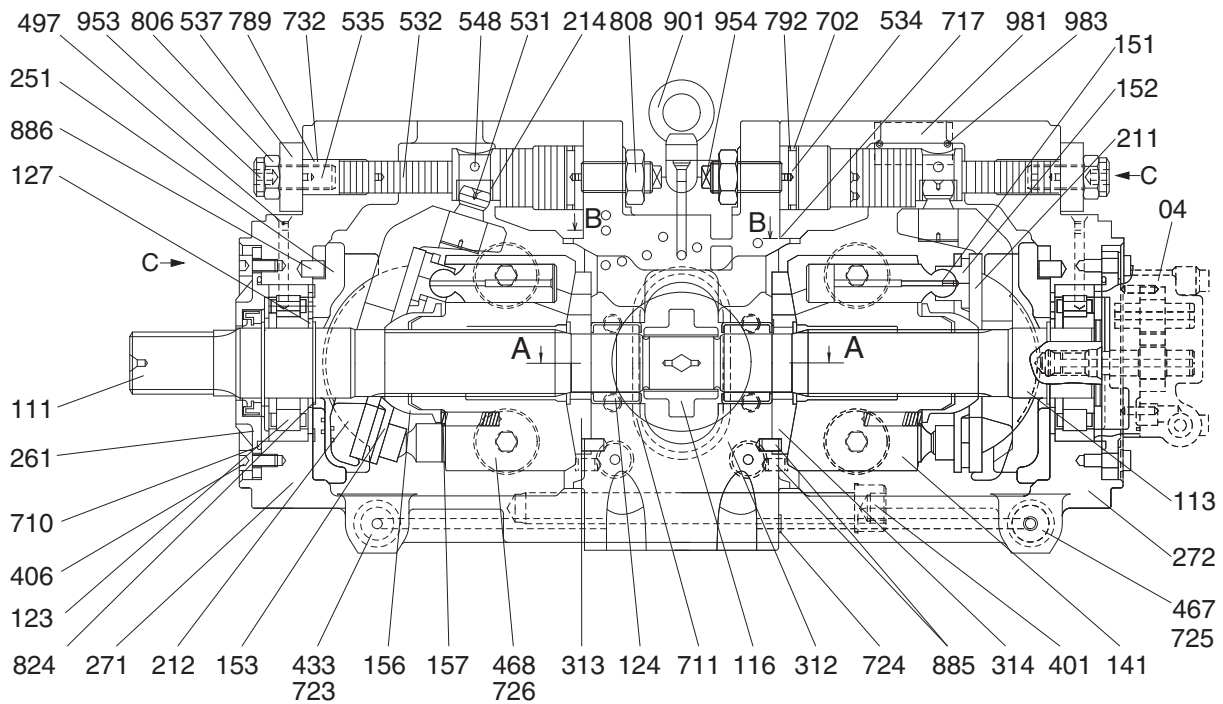

※ Section A-A, B-B, view C : see next page.

220S2MP05

04	Gear pump	272	Pump casing (R)	711	O-ring
111	Drive shaft (F)	312	Valve block	717	O-ring
113	Drive shaft (R)	313	Valve plate (R)	723	O-ring
116	1st gear	314	Valve plate (L)	724	Square ring
123	Roller bearing	401	Hexagon socket bolt	725	O-ring
124	Needle bearing	406	Hexagon socket bolt	726	O-ring
127	Bearing spacer	466	Plug	732	O-ring
141	Cylinder block	467	Plug	774	Oil seal
151	Piston	468	Plug	789	Back up ring
152	Shoe	497	MH Plug	792	Back up ring
153	Set plate	531	Tilting pin	806	Hexagon head nut
156	Spherical bushing	532	Servo piston	808	Hexagon head nut
157	Cylinder spring	534	Stopper (L)	824	Snap ring
211	Shoe plate	535	Stopper (S)	885	Pin
212	Swash plate	537	Servo cover (S)	886	Pin
214	Tilting Bushing	548	Feed-back pin	901	Eye bolt
251	Support	702	O-ring	953	Set screw
261	Seal cover (F)	710	O-ring	954	Set screw
271	Pump casing (F)				

MAIN PUMP (2/3)

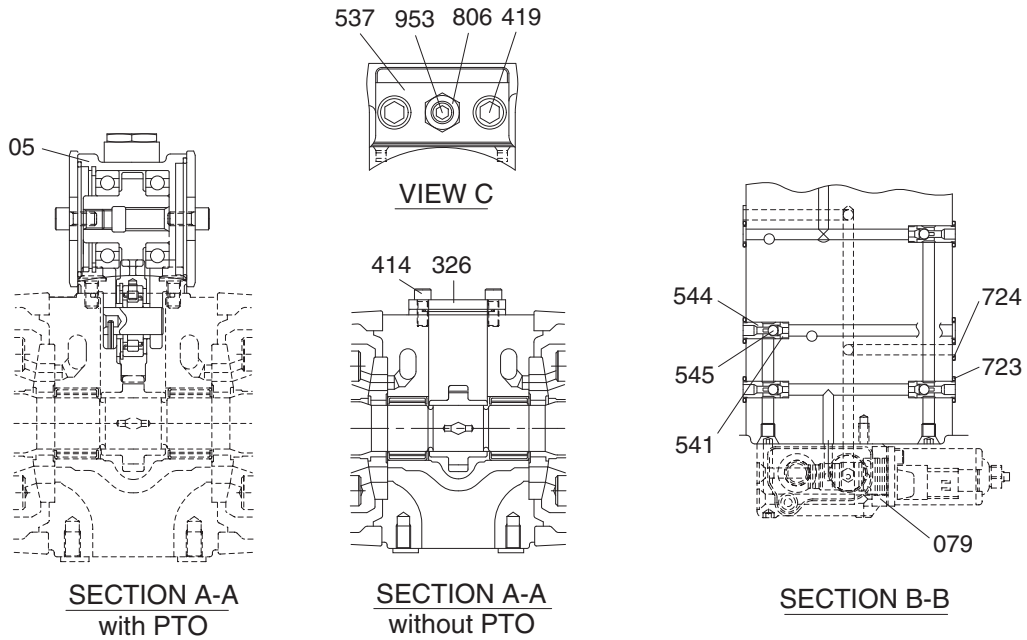

220S2MP06

05	PTO unit (with PTO)	537	Servo cover (S)	724	Square ring
079	Proportional reducing valve	541	Seat	806	Hexagon head nut
326	Cover (without PTO)	544	Stopper 1	953	Set screw
414	Hexagon socket bolt (without PTO)	545	Steel ball		
419	Hexagon socket bolt	723	O-ring		

MAIN PUMP (3/3)

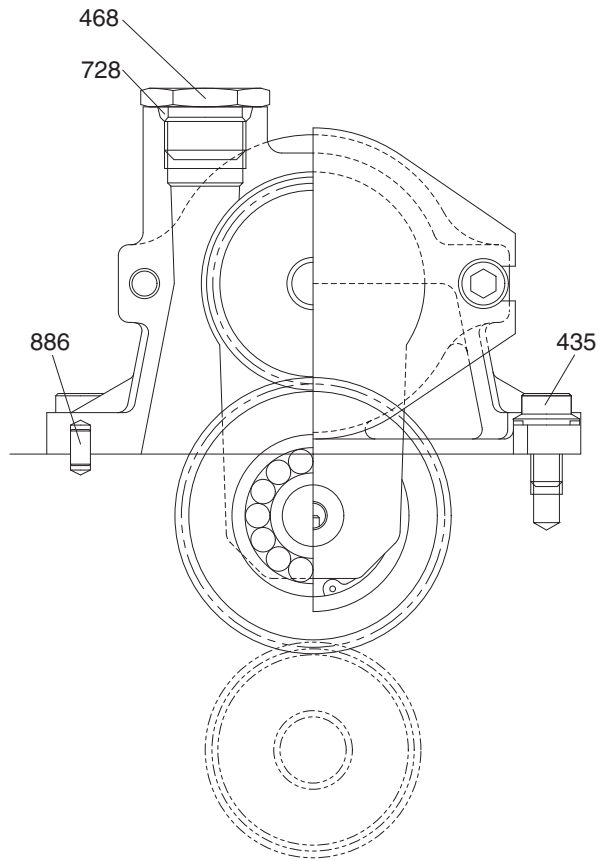
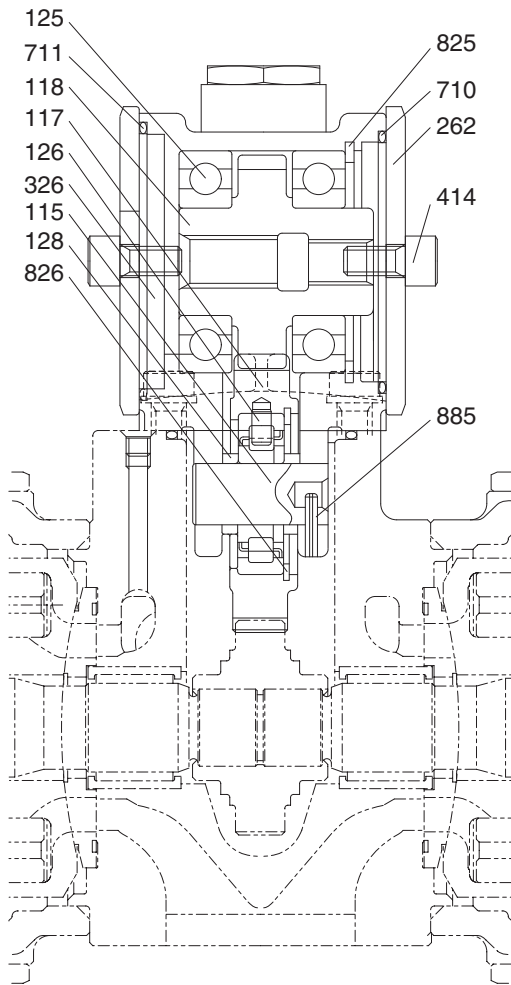

220S2MP07

115 Idler shaft	262 Cover	711 O-ring
117 Gear No. 2	326 Gear case	728 O-ring
118 Gear No. 3	414 Socket head screw	825 Retainer ring
125 Ball bearing	435 Flange head socket bolt	826 Retainer ring
126 Roller bearing	468 Plug	885 Spring pin
128 Bearing spacer	710 O-ring	886 Pin

2) TOOLS AND TIGHTENING TORQUE

(1) Tools

The tools necessary to disassemble/reassemble the pump are shown in the following list.

Tool name & size		Part name		
Name	B	Hexagon socket head bolt	ROH, VP plug (Parallel thread)	Hexagon socket head setscrew
Allen wrench 	6	M 8	PF 1/4	M12, M14
	8	M10	PF 3/8	M16, M18
	10	M12	PF 1/2	M20
	14	M16, M18	PF 3/4	-
	17	M20, M22	PF 1	-
Adjustable angle wrench		Medium size, 1 set		
Screw driver		Minus type screw driver, Medium size, 2 pieces		
Hammer		Plastic hammer, 1 pieces		
Pliers		For snap ring, TSR-160		
Torque wrench		Capable of tightening with the specified torques		

(2) Tightening torque

Part name	Bolt size	Torque		Wrench size	
		kgf · m	lbf · ft	in	mm
Hexagon socket head bolt (Material : SCM435)	M 5	0.7	5.1	0.16	4
	M 6	1.2	8.7	0.20	5
	M 8	3.0	21.7	0.24	6
	M10	5.8	42.0	0.31	8
	M12	10.0	72.3	0.39	10
	M14	16.3	118	0.47	12
	M16	23.5	170	0.55	14
	M18	33.7	244	0.55	14
	M20	43.8	317	0.67	17
ROH Plug PF 3/8 or under : S45C PF 1/2 or under : SCM435	PF 1/4	3.0	21.7	0.24	6
	PF 3/8	7.5	54.2	0.31	8
	PF 1/2	10.0	72.3	0.39	10
	PF 3/4	15.3	111	0.47	12

3) DISASSEMBLY

For disassembling the pump, read this section thoroughly and then disassemble it in the following sequence. The figure in parentheses after part names show the item in structure drawing.

- (1) Select place suitable to disassembling.
 - ※ Select clean place.
 - ※ Spread rubber sheet, cloth or so on.
Make workbench top clean to prevent parts from being damaged.
- (2) Remove dust, rust, etc, from pump surfaces with cleaning oil or so on.
- (3) Remove drain port plug (468) and let the oil out from pump casing (271, 272).
- (4) Remove hexagon socket head bolts (412, 413, 414) and remove regulator.
 - ※ Refer to page 8-28 for disassemble regulator.

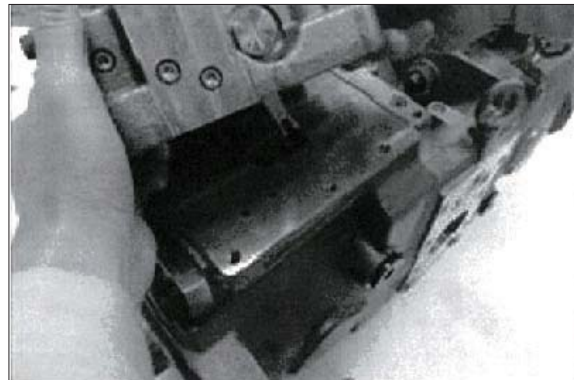

220S8MP11

- (5) Remove hexagon socket head bolts and remove proportional valve block (079).



220S8MP12

(6) Place the pump horizontally on workbench with its regulator-fitting surface down, and remove PTO unit from valve block.

- ※ Before bringing regulator-fitting surface down, spread rubber sheet on workbench to avoid damaging the surface.

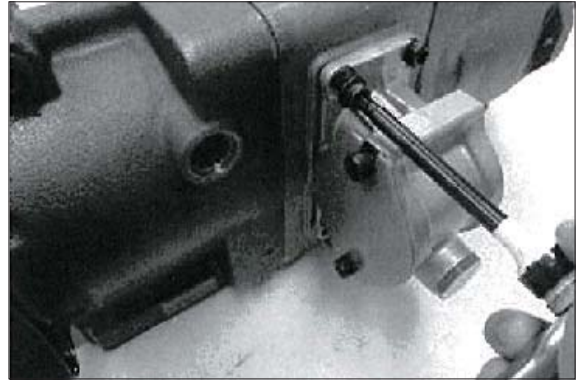

220S8MP13

- ※ In case the pump is provided without PTO unit, remove the cover (326) with the hexagon socket head cap screws.



220S8MP14

(7) Remove flange sockets (435) and the gear pump (04).

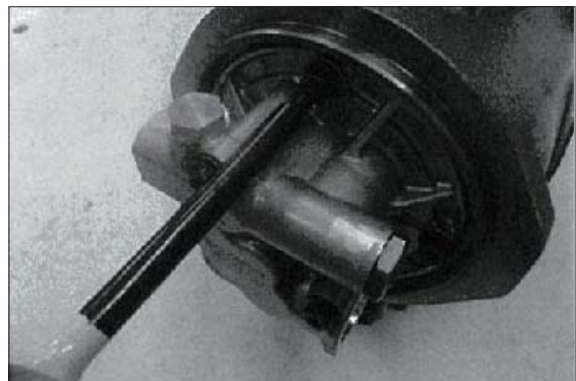

220S8MP15

(8) Loosen hexagon socket head bolts (401) which tighten pump casing (F, 271) pump casing (R, 272), and valve block (312).

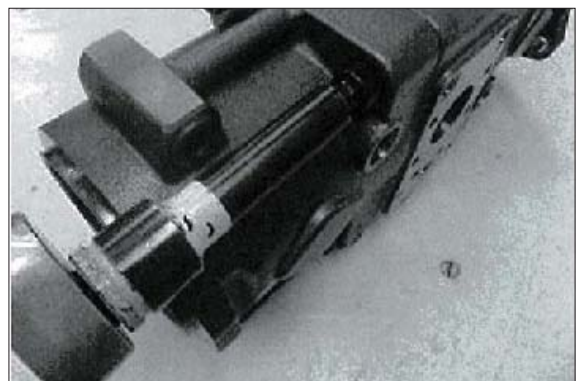

220S8MP16

- (9) Separate pump casing (F, 271), pump casing (272), from valve block (312)
- ※ Remove the 1st gear (116), when pump casings are separated from valve block.

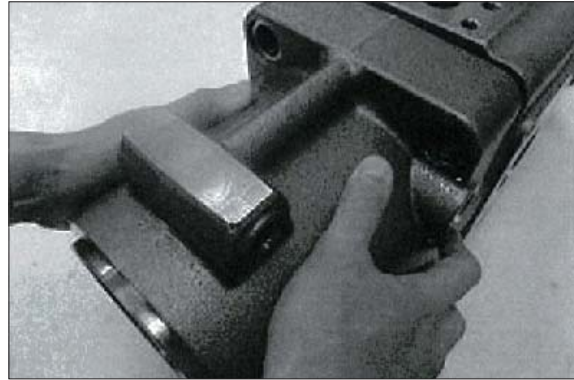

220S8MP17

- (10) Pull out cylinder block (141), piston-shoes (011), set plate (153), spherical bush (156), and cylinder springs (157) simultaneously from pump casing (F, 271) and (R, 272), straightly over drive shaft (111, 113)
- ※ Take care not to damage sliding surface of cylinder block (141), spherical bush (156), piston-shoes (011), swash plate (212), drive shaft (111, 113), etc.



220S8MP18

- (11) Remove hexagon socket head bolts (406) and seal cover (F, 261)
- ※ In the case it is difficult to remove, put flat-blade screwdriver into the notch of seal cover. Then the cover can be removed easily.
 - ※ Since oil seal is fitted on seal cover (F, 261), take care not to damage it while removing cover.

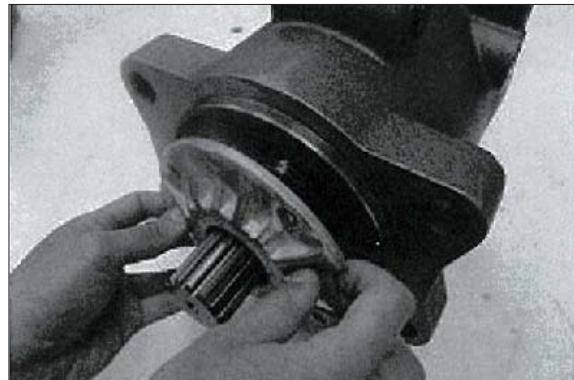

220S8MP19

- (12) Remove the drive shafts (111, 113) from the pump casing (271, 272).
- ※ In the case it is difficult to remove, tap the end of the drive shaft lightly with plastic hammer.



220S8MP20

- (13) Remove the swash plates (212) and shoe plates (211) from swash plate support (251), and pull out the swash plates with turning shown in this picture from casing.



220S8MP21



220S8MP22

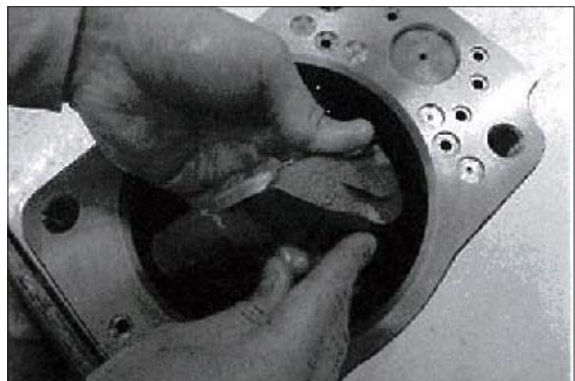

220S8MP23

- (14) Remove swash plate supports (251) from pump casing.

- ※ In this case it is difficult to remove, tap the opposite side of the swash plate support (251) with plastic hammer to remove it from pump casing easily.

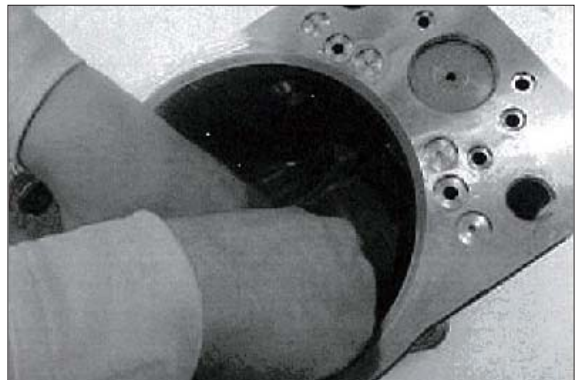

220S8MP24

(15) Remove valve plates (313, 314) from valve block (312)

※ There may be removed in work (8).

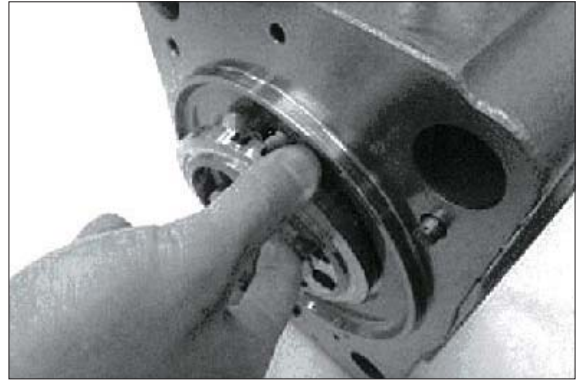

220S8MP25

(16) If necessary, remove the servo covers (537), stopper (L, 534), stopper (S, 535), and servo piston sub (530) from pump casing (271, 272).

※ Do not remove needle bearing (124) as far as possible, except the case that the bearing is considered to be out of its life-time.

※ Do not loosen hexagon nuts of valve block (312) and servo cover (537). If loosened, flow setting will be changed.

4) REASSEMBLY

(1) For reassembling reverse the disassembling procedures, paying attention to the following.

- ① Do not fail to repair the parts damaged during disassembling, and repair replacement part in advance.
- ② Clean each part fully with cleaning oil and dry it with compressed air.
- ③ Apply clean working oil to sliding sections, bearings, etc. before assembling them.
- ④ In general rule, replace the sealing parts, such as O-ring, oil seal, etc.
- ⑤ For fitting bolts, plug, etc. prepare a torque wrench or so on, and tighten them with torque shown at page 8-13.
- ⑥ For the tandem type pump, take care not to mix up parts of the front pump with those of the rear pump

(2) Insert swash plate supports (251) into the casing (271) and (R, 272) with fitting.

- ※ If the servo piston, stopper (L), stopper (S), and servo cover are removed, fit them to pump casing in advance for reassembling.

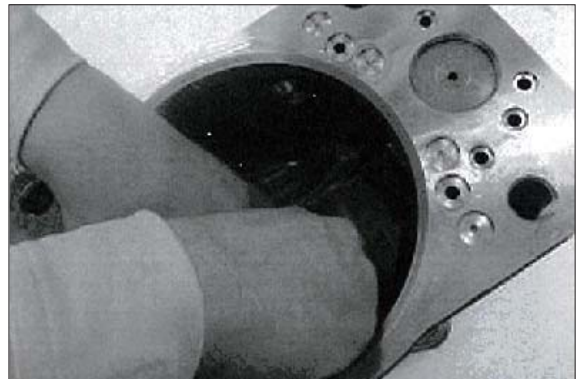

220S8MP24

(3) Attach shoe plate (211) to swash plate (212) and insert tilting pin (531) to tilting bush (214) of servo piston (532). As shown in the right figure, attach to swash plate support (251) correctly, leaning swash plate and shoe plate.

※ Confirm that swash plate can moved smoothly with fingers of both hands.

※ Apply grease to sliding sections of swash plate and swash plate support, to assemble the drive shaft easily.

※ Take care not to damage the sliding surface of the shoe plate.

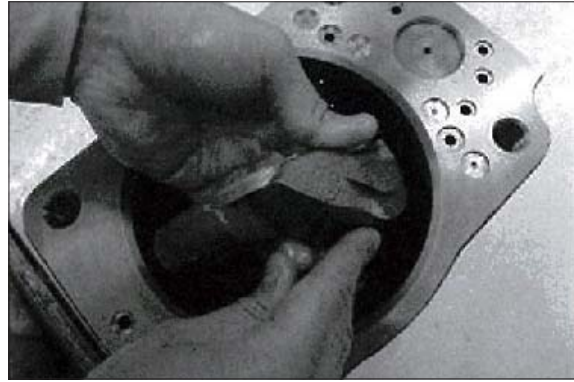

220S8MP23



220S8MP22



220S8MP21

(4) Fit drive shaft (111, 113) where bearing (123), bearing spacer (127), snap ring (824) were set to pump casing (271, 272).



220S8MP20

(5) Assemble seal cover (F, 261) to pump casing (271) and fix it with hexagon socket head bolts (406).

- ※ Apply grease lightly to oil seal in seal cover (F).
- ※ Assemble oil seal, taking full care not to damage it.

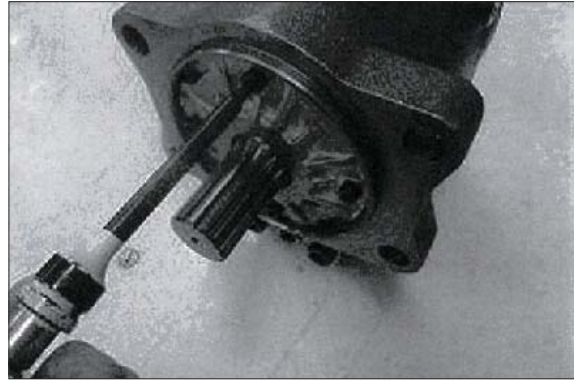

220S8MP26

(6) Assemble piston cylinder sub assembly [cylinder (141), piston sub assembly (151, 152), set plate (153), spherical bush (156) and cylinder spring (157)].

- ※ Fit spline phases of spherical bush and cylinder.
- ※ Then, insert piston cylinder subassembly into pump casing.



220S8MP18

(7) Fit valve plate (313) to valve block (312) according to pin (885).

- ※ Take care not to mistake suction/delivery directions of valve plate.

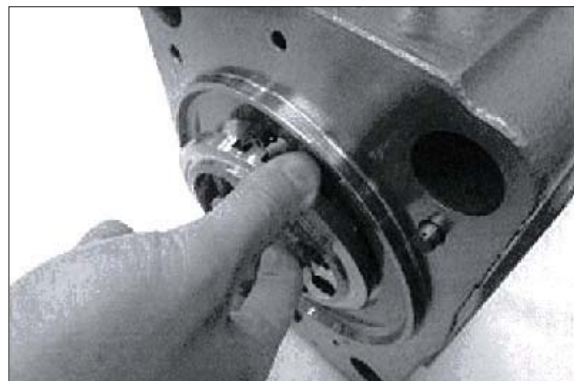

220S8MP27

(8) Place pump horizontally on workbench with its regulator-fitting surface down, and attach pump casing (271) to valve block (312).

- ※ Before bringing regulator-fitting surface down, spread rubber sheet on workbench and do not damage this surface.
- ※ Take care not to mistake direction of valve block. [clockwise rotation (viewed from input shaft side)]. Fit the valve block with suction flange left when regulator side below, viewed from front side.
- ※ Fit 1st gear simultaneously.



220S8MP17

- (9) Fit valve block (312) to pump casing (271, 272) with hexagon socket head bolts (401, 402).

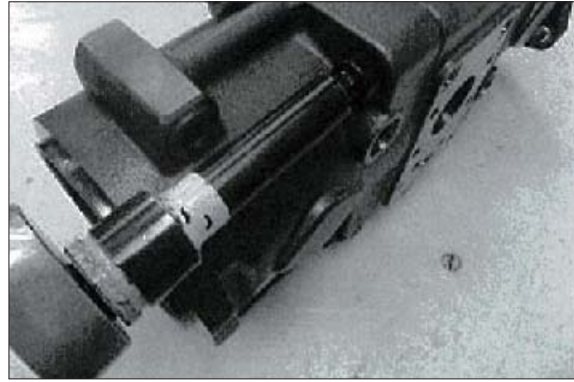

220S8MP16

- (10) Fit gear pump (04) to pump casing (271) with hexagon socket head bolts.



220S8MP15

- (11) Attach the PTO unit (05) by fastening the flange socket to the valve block (312).
※ Be careful about the attaching direction of the PTO unit.

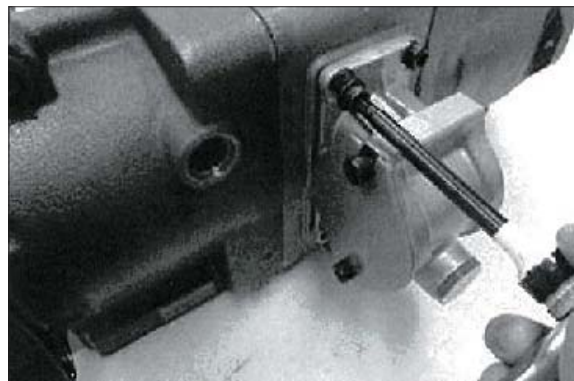

220S8MP13

In case the pump is not provided with the PTO unit (05), attach the cover (326) with the hexagon socket head cap screws (414).



220S8MP14

(12) Putting feedback lever of regulator into feedback pin (548) of servo piston (532), fit regulator with hexagon socket head bolts.

※ Take care not to mix up regulator of front pump with another.

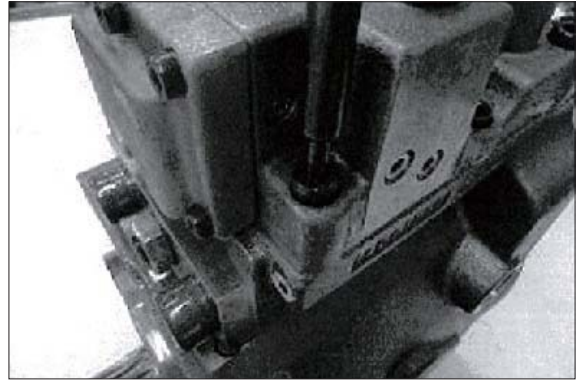

220S8MP28

(13) Fit proportional valve block (079) to valve block (312) with hexagon socket head bolts.

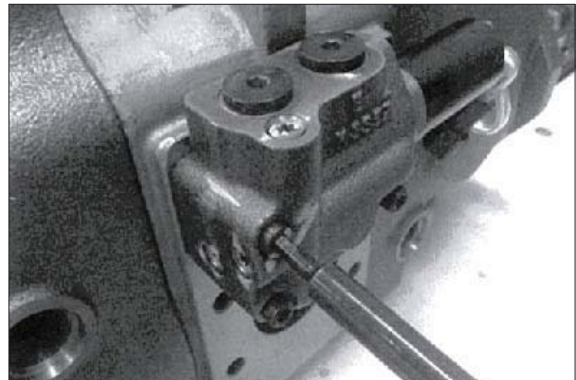

220S8MP29

(14) Fit drain port plug (467).

This is the end of reassembling procedure.

3. REGULATOR

1) STRUCTURE (1/2)

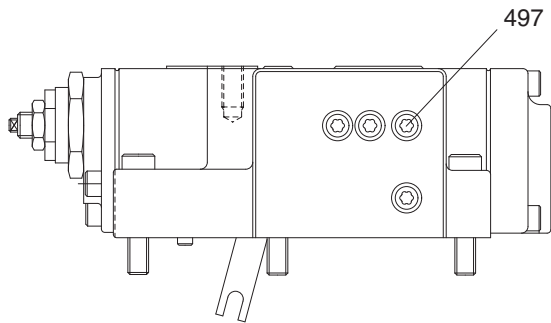
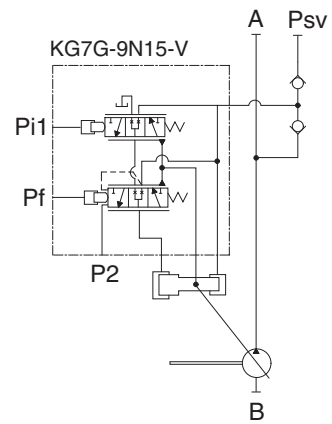
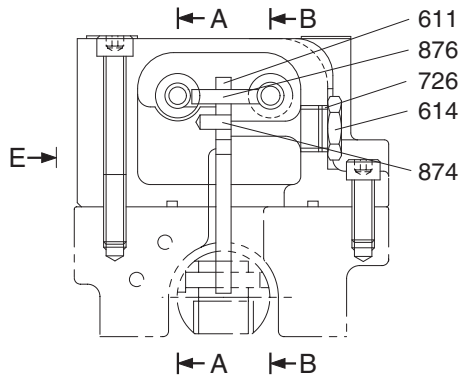

VIEW E

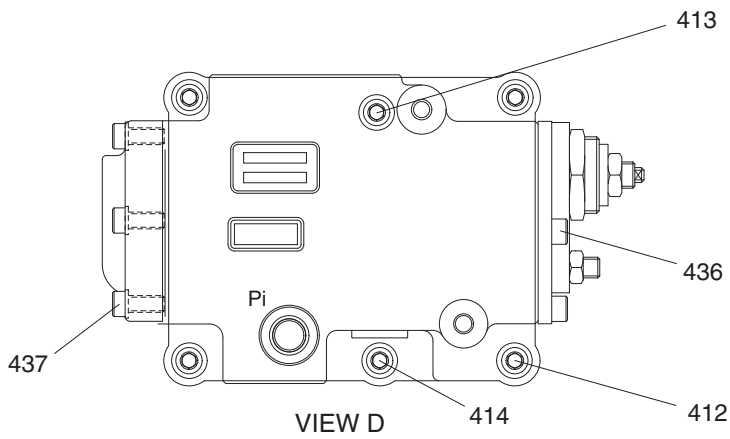

VIEW D

- | | | |
|--------------------------|---------------------|---------|
| 412 Hexagon socket screw | 497 Plug | 874 Pin |
| 413 Hexagon socket screw | 611 Feed back lever | 876 Pin |
| 436 Hexagon socket screw | 614 Adjust plug | |
| 437 Hexagon socket screw | 726 O-ring | |

220S2MP08

REGULATOR (2/2)

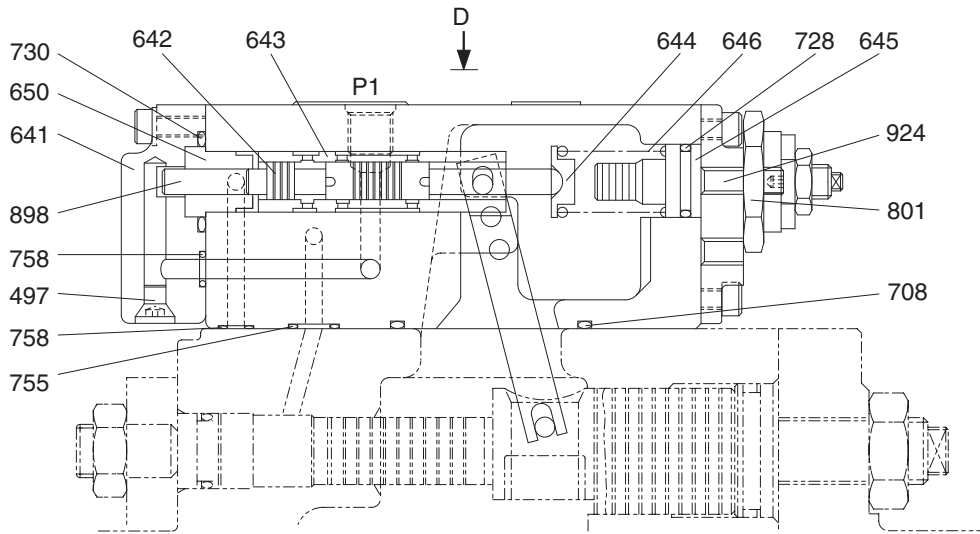

SECTION B-B

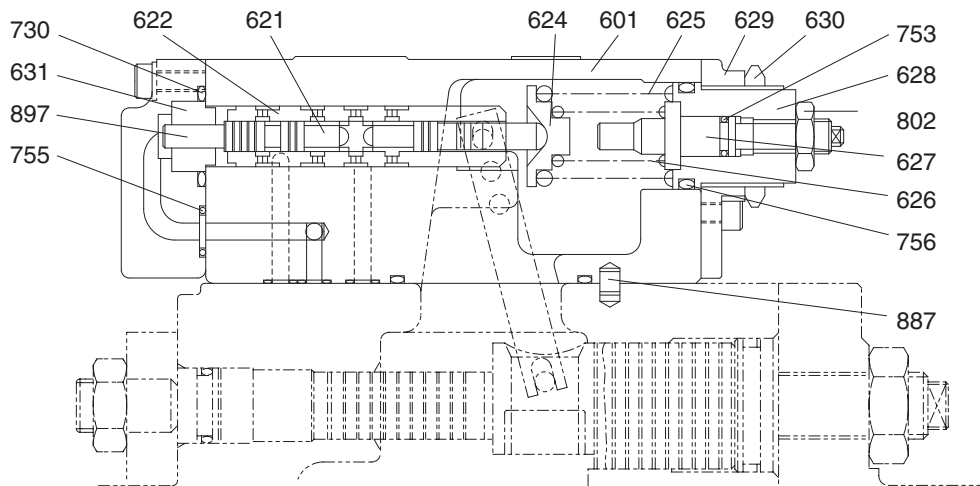

SECTION A-A

220S2MP09

414 Hexagon socket screw	630 Lock nut	730 O-ring
497 Plug	631 Sleeve, pf	753 O-ring
601 Casing	641 Pilot cover	755 O-ring
621 Compensator piston	642 Pilot spool	756 O-ring
622 Compensator sleeve	643 Pilot sleeve	758 Square ring
624 Spring seat (C)	644 Spring seat (Q)	801 Nut
625 Outer spring	645 Adjust stem (Q)	802 Nut
626 Inner spring	646 Pilot spring	887 Pin
627 Adjust stem (C)	650 Sleeve, pi	897 Piston, pf
628 Adjust screw (C)	708 O-ring	898 Piston, pi
629 Cover (C)	728 O-ring	924 Set screw

2) TOOLS AND TIGHTENING TORQUE

(1) Tools

The tools necessary to disassemble/reassemble the pump are shown in the following list.

Tool name & size		Part name		
Name	B	Hexagon socket head bolt	ROH, VP, UNF (Parallel thread)	Hexagon socket head setscrew
Allen wrench 	4	M 5	-	M8
	5	M 6	-	M10
	6	M 8	ROH 1/4	M12, M14
	19	-	-	-
	22	-	VP 3/8	-
Adjustable angle wrench		Medium size, 1 set		
Torque wrench		Capable of tightening with the specified torques		
Hexagon socket head bolt		M4, Length : 50 mm		

(2) Tightening torque

Part name	Bolt size	Torque		Wrench size	
		kgf · m	lbf · ft	in	mm
Hexagon socket head bolt (Material : SCM435)	M 5	0.7	5.1	0.16	4
	M 6	1.2	8.7	0.20	5
	M 7	3.0	21.7	0.24	6
	M 8	5.8	42	0.31	8
	M 9	10.0	72.3	0.39	10
	M14	16.3	118	0.47	12
	M16	23.5	170	0.55	14
	M18	33.7	244	0.55	14
	M20	43.8	317	0.67	17
	M22	64.2	464	0.67	17
PT Plug (Material : S45C) ※ Wind a seal tape 1 1/2 to 2 turns round the plug	PT 1/8	1.2	8.7	0.20	5
	PT 1/4	2.2	15.9	0.24	6
	PT 3/8	4.5	32.5	0.31	8
	PT 1/2	6.6	47.7	0.39	10
ROH Plug PF 3/8 or under : S45C PF 1/2 or over : SCM435	PF 1/4	3.5	25.3	0.24	6
	PF 3/8	7.5	54.2	0.31	8
	PF 1/2	11.2	81.0	0.39	10
	PF 3/4	17.3	125	0.55	14
UNF plug (Material : S45C)	PPU916 W	1.6	11.6	0.75	19

3) DISASSEMBLY

(1) Preparation for disassembling

- ① Since the regulator consists of small, precision, and well-finished parts, disassembling and assembling are rather complicated. For this reason, replacement of a regulator assembly is recommended, unless there is a special reason. If in case disassembling is necessary for an unavoidable special reason, read through this manual to the end before starting disassembling.
- ② Since the regulators on the front pump and the rear pump are set at different pressure and flow values, mark each of them so as not to mix up one of front pump with another.
- ③ The numbers in parentheses after part names represent those in the cross-sectional drawings (on page 8-24, 25)

(2) Select a place for assembling.

- ※ Select clean place.
- ※ Spread rubber sheet or cloth to over the workbench to prevent parts from being damaged.

(3) Remove dust, rust, etc. from surfaces of regulator with clean oil.

- ※ Since the regulators on the front side and the rear side set at different pressure and flow values, mark each of them so as not to mix up one of drive shaft side with another.

(4) Remove hexagon socket head cap screws (412, 413, 414) and remove regulator from the pump.

- ※ If the pump is disassembled, check the page 7-21 for this axial piston pump.
- ※ Take care not to lose O-ring while removing regulator.

(5) Remove hexagon socket head cap screw (436). Then remove cover (C, 629).

※ Adjusting screw (C, 628), adjust stem (C, 627), hexagon nut (801, 802), set screw (924) are fixed to cover (C, 629).

※ Do not loosen each screw and nut. If they are loosened, adjusted pressure-flow setting will be changed.

※ At first, remove A-B hexagon socket head cap screws (436) equally, then remove C-D hexagon socket head cap screws (436) equally.

※ As spring force is strong, casting (601) and adjust stem (C, 627) may be damaged if cover (C, 629) is inclined.

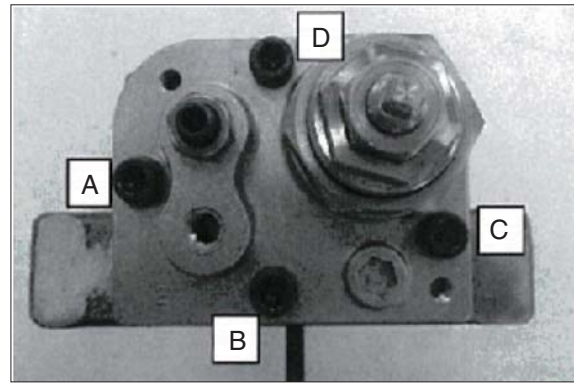

220S8MP30

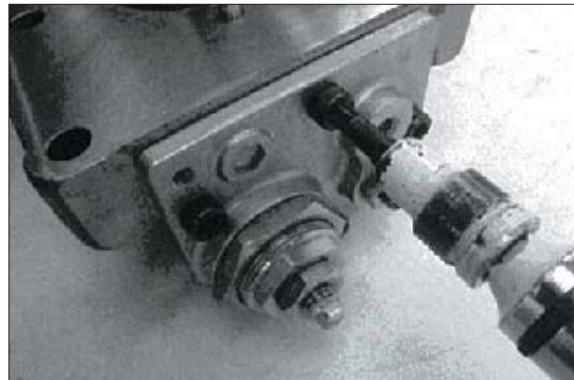

220S8MP31



220S8MP32

(6) Remove the adjusting stem (Q, 645) the pilot spring (646), and the spring seat (Q, 644) from pilot section of the regulator.

※ Adjusting stem (Q, 645) can easily be pull out with M4 screw.

※ Take care not to lose the pilot spring (646) and the spring stem (Q, 644) which they fall from casing when the adjusting stem (Q, 645) is removed.

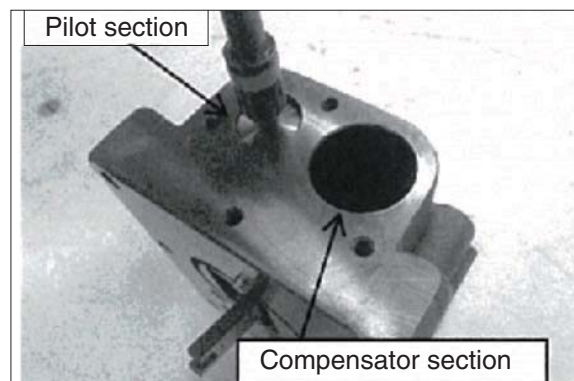

220S8MP33

- (7) Remove hexagon socket head cap screw (437) and remove pilot cover (641).
- ※ Then remove Pf piston (897), Pf sleeve (631), Pi piston (898), and Pi sleeve (650) from pilot cover.
 - ※ If the regulator was used for a long time, the Pf sleeve (631) or the Pf sleeve (650) may stuck with pilot cover. Take care not to damage these sleeves while removing them from the pilot cover. (641).

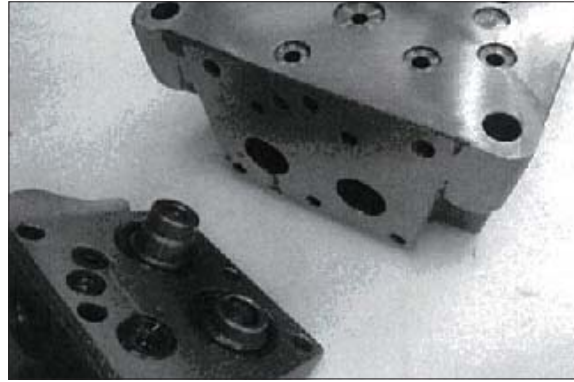

220S8MP34

- (8) Remove the compensator spool (621) and the pilot spool (642) from casing.
- ※ Remove the compensator spool (621) from the casing by one direction shown in left picture. Regulator parts will be damaged and broken, if the spool is pushed to counter direction shown in left picture.

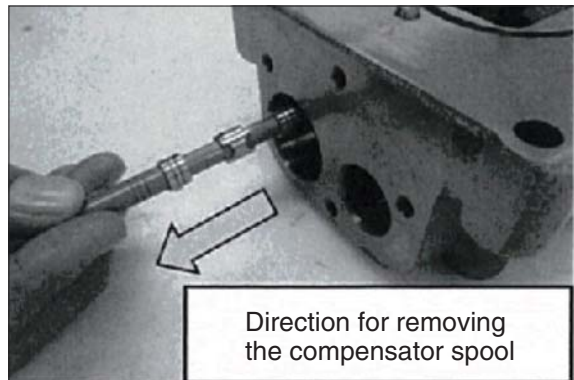

220S8MP35

- (9) Remove the adjusting plug (614) and feedback lever (611) from the casing.
- ※ Be careful not to damage regulator casing (601) while loosening the adjusting plug (614).
 - ※ Do not remove the pin (876) from the feedback lever (611).



220S8MP36

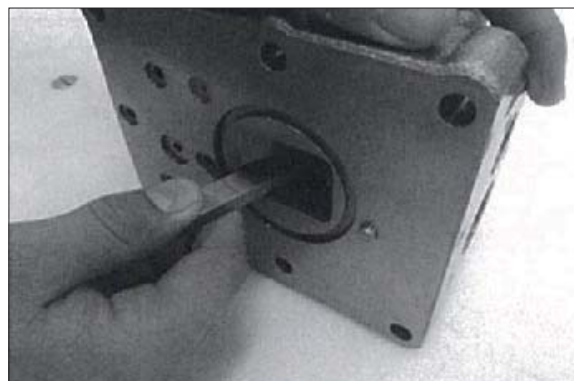

220S8MP37

(10) Remove the compensator sleeve (622) and the pilot sleeve (643) from the casing (601).

※ This completes operation.

Since component parts are small, take care not to lose them.

4) REASSEMBLY

(1) For assembling, reverse disassembling procedures. But pay attention to the following.

- ① Repair parts that were damaged at disassembling.
Prepare replacement parts beforehand.
- ② Contamination will cause malfunction.
Therefore, wash parts well with cleaning oil, let them dry with jet air and handle them in clean place.
- ③ Tighten screws, plugs, etc. with their specified torques.
- ④ Replace seals such as O-ring with new ones as a general rule.

(2) Select a place for assembling.

- ※ Select clean place.
- ※ Spread rubber sheet or cloth to cover the workbench to prevent parts from being damaged.

(3) Fit the compensator sleeve (622) and the pilot sleeve (643) into the casing (601).

- ※ Make sure that the position of the compensator sleeve (622) and the pilot sleeve (643) are correct.
- ※ Confirm that these sleeves slide smoothly in casing without sticking.

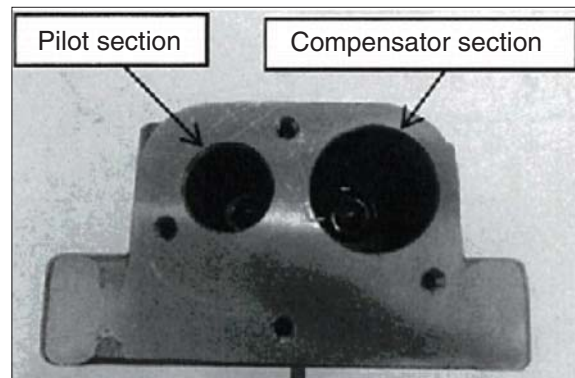

220S8MP38

- (4) Insert the pin (876) fixed on feedback lever (611) to the oval shaped hole of the pilot sleeve (643). Then, fit the hole of the feedback lever to the pin (874) fixed inside the casing (601). At the same time, insert the pin (876) to the oval shaped hole of the compensator sleeve (622).

- ※ If the pilot spool (642) is in the pilot sleeve (643), the pin (876) cannot be inserted to the pilot sleeve.

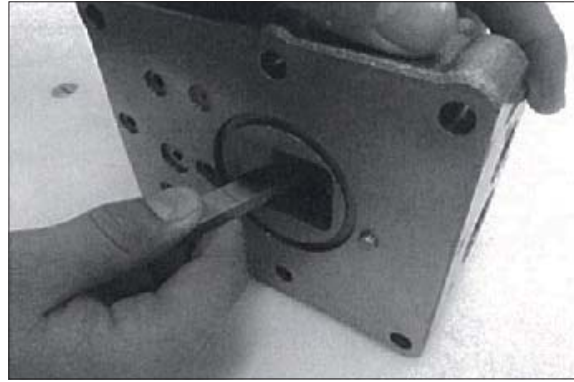

220S8MP37

- (5) Tighten the adjusting plug (614) to the casing (601).

- ※ Be careful not to damage regulator casing (601) while tightening the adjusting plug (614)
- ※ Confirm that the sleeves slide smoothly in casing with sticking or excess play among parts.



220S8MP39

- (6) Fit the compensator spool (621) into the compensator (622) and the pilot spool (642) into the pilot sleeve (643).

- ※ Fit the compensator spool (621) into the compensator sleeve (642) by direction shown in left picture.



220S8MP40

- (7) Put the piston (897), the Pf sleeve (631), the pilot piston (898) and the pilot sleeve (650) into pilot cover (641). Then fit the cover to the casing (601).

- ※ Make sure that the direction of Pf piston and Pi piston are correct.
- ※ Make sure that the position of Pf piston and Pi piston are correct.
- ※ Be careful not to fall Pf piston and other parts.



220S8MP34

(8) Put the spring seat (C, 624) the outer spring (625), and the inner spring (626) into compensator section of the casing.

By the same way, put the spring seat (Q, 644) into pilot section of the casing.

- ※ The spring seat (C, 624) may fall. Apply grease to the spring seat (C, 624), the outer spring (625) and the inner spring (626) to prevent falling. Also the pilot spring seat (Q, 644) and the pilot spring (646) should be assembled as well.

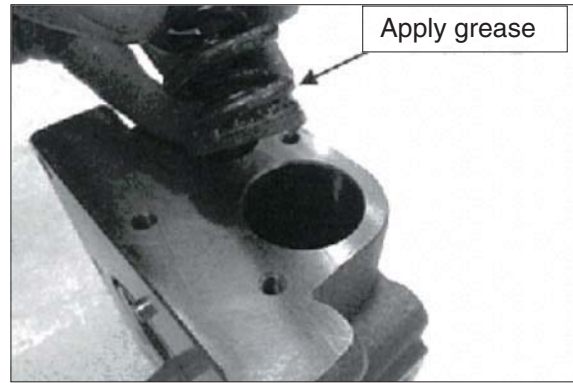

220S8MP41

(9) Tighten cover (C, 629) with hexagon socket head cap screws (436).

- ※ Adjusting screw (C, 628), adjust stem (C, 627), hexagon nut (801, 802), set screw (924) are fixed on cover (C, 629).

Do not loosen screw and nut. If they are loosened, adjusted pressure-flow setting will be changed.

- ※ At first, tighten C·D hexagon socket head cap screws (436) equally, then tighten A·B hexagon socket head cap screws (436) equally.

- ※ At spring force is strong, casing (601) and adjust stem (C, 627) may be damaged if cover (C, 629) inclined.



220S8MP32

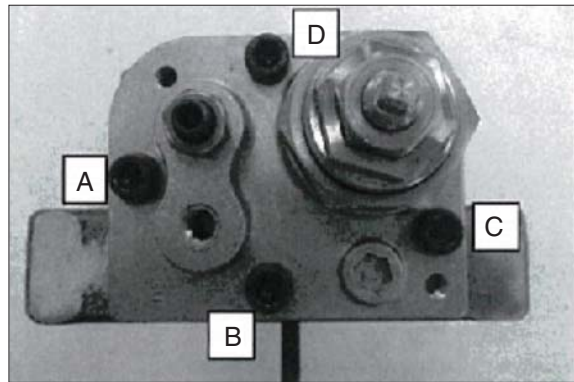

220S8MP30

(10) Put the regulator to the pump. Tighten regulator with hexagon socket head cap screws (412, 413, 414).

This completes assembling.

GROUP 4 MAIN CONTROL VALVE

1. REMOVAL AND INSTALL OF MOTOR

1) REMOVAL

- (1) Lower the work equipment to the ground and stop the engine.
- (2) Operate the control levers and pedals several times to release the remaining pressure in the hydraulic piping.
- (3) Loosen the breather slowly to release the pressure inside the hydraulic tank.
- ▲ **Escaping fluid under pressure can penetrate the skin causing serious injury.**
- ※ When pipes and hoses are disconnected, the oil inside the piping will flow out, so catch it in oil pan.
- (4) Remove the wirings for the pressure sensor and so on.
- (5) Remove bolts and disconnect pipe.
- (6) Disconnect pilot line hoses.
- (7) Disconnect pilot piping.
- (8) Sling the control valve assembly and remove the control valve mounting bolt and bracket.

- Weight : 220 kg (485 lb)
- Tightening torque : $12.3 \pm 1.3 \text{ kgf} \cdot \text{m}$
($89.0 \pm 9.4 \text{ lbf} \cdot \text{ft}$)

- (9) Remove the control valve assembly.
When removing the control valve assembly, check that all the piping have been disconnected.

2) INSTALL

- (1) Carry out installation in the reverse order to removal.
- (2) Bleed the air from below items.
 - ① Cylinder (boom, arm, bucket)
 - ② Swing motor
 - ③ Travel motor※ See each item removal and install.
- (3) Confirm the hydraulic oil level and recheck the hydraulic oil leak or not.

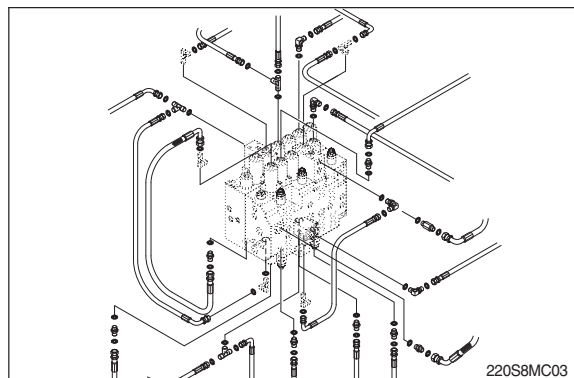
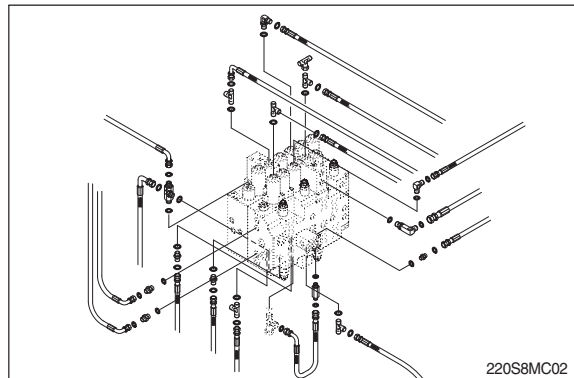
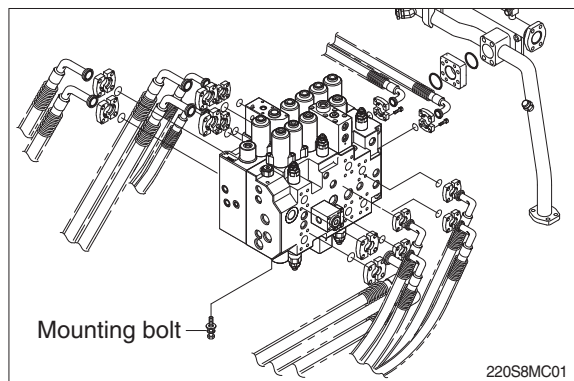

2. STRUCTURE (1/5)

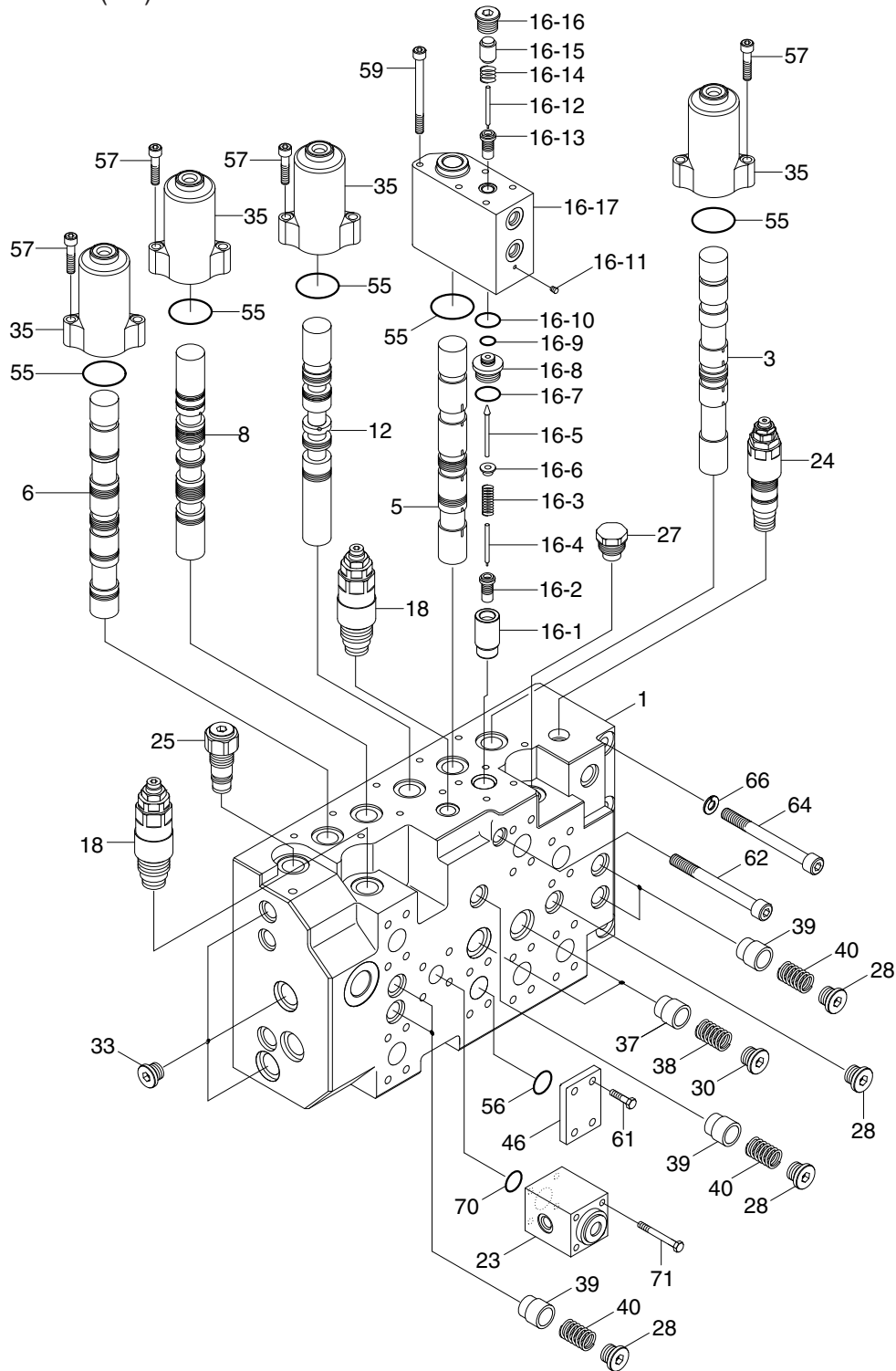

- | | | | | | |
|----|------------------------|----|------------------|----|---------------|
| 1 | P1 housing | 27 | Overload plug | 56 | O-ring |
| 3 | Travel spool kit | 28 | Plug | 57 | Socket bolt |
| 5 | Boom 1 spool kit | 30 | Load check plug | 59 | Socket bolt |
| 6 | Bucket spool kit | 33 | Plug | 61 | Socket bolt |
| 8 | Arm 2 spool kit | 35 | Spool cap | 62 | Socket bolt |
| 12 | Arm regen spool kit | 37 | L/C poppet 1 | 64 | Socket bolt |
| 16 | Holding valve assy | 38 | L/C spring 1 | 66 | Spring washer |
| 18 | Port relief valve assy | 39 | L/C poppet 2 | 70 | O-ring |
| 23 | Arm 2 logic valve assy | 40 | L/C spring 2 | 71 | Socket bolt |
| 24 | Main relief valve assy | 46 | Port plug flange | | |
| 25 | Negacon relief valve | 55 | O-ring | | |

220S8MC04

STRUCTURE (2/5)

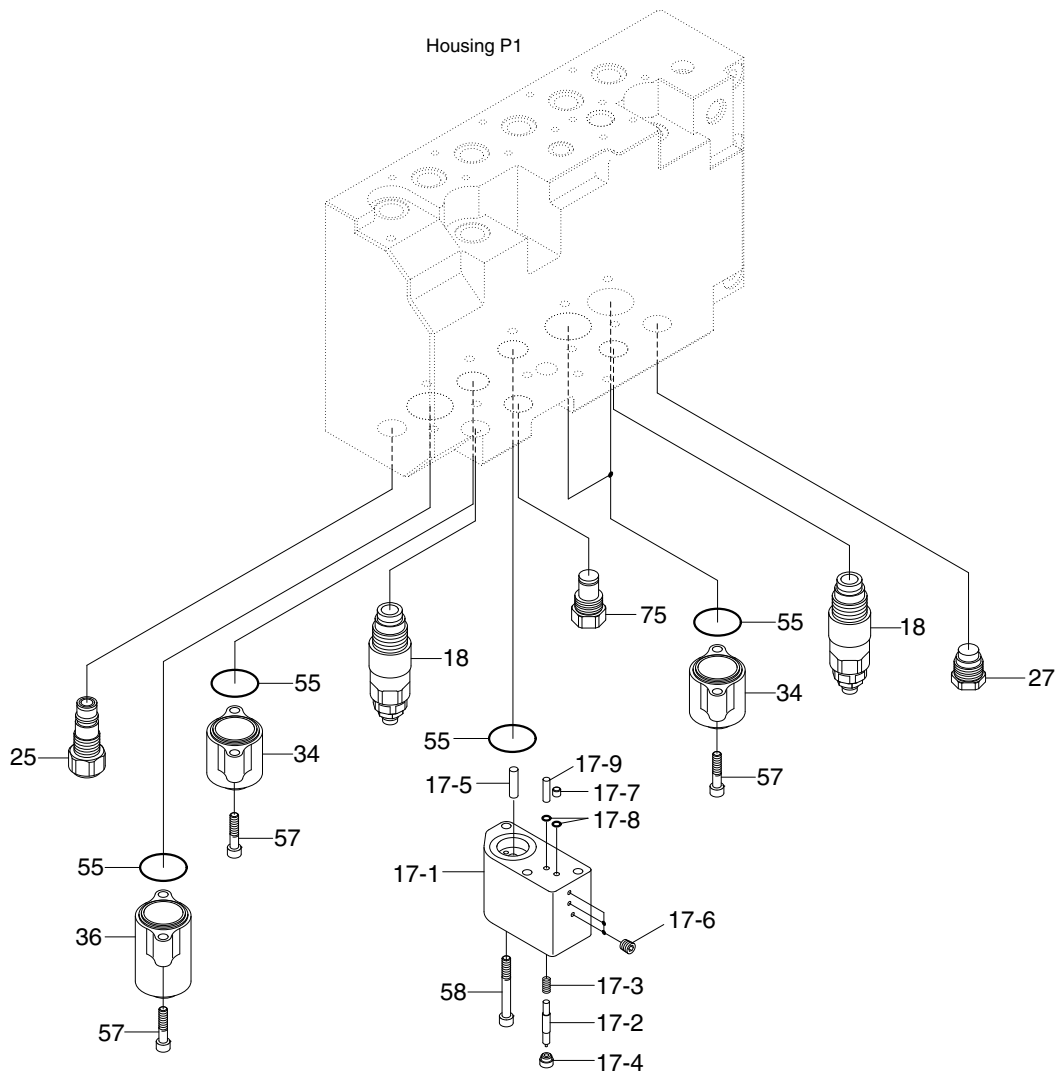

220S8MC05

- | | | | | | |
|----|------------------------|----|---------------------|----|-------------|
| 17 | Regen valve assy | 34 | Spool cap | 58 | Socket bolt |
| 18 | Port relief valve assy | 36 | Bucket stroke limit | 75 | Plug assy |
| 25 | Negacon relief valve | 55 | O-ring | | |
| 27 | Overload plug | 57 | Socket bolt | | |

STRUCTURE (3/5)

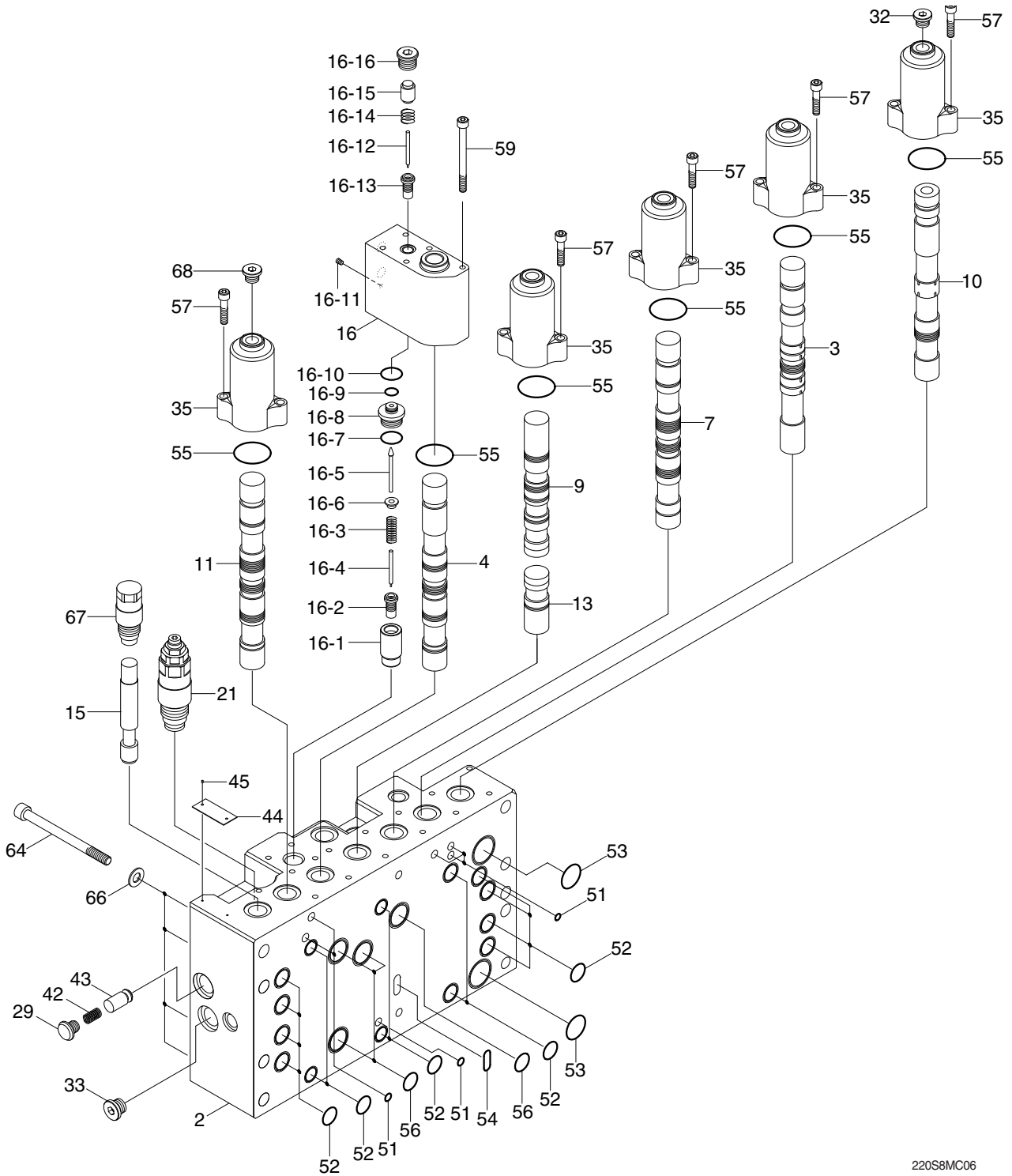

220S8MC06

- | | | | | | |
|----|---------------------------|----|------------|----|-----------------------------|
| 2 | P2 housing | 29 | Plug | 54 | O-ring |
| 3 | Travel spool kit | 32 | Plug | 55 | O-ring |
| 5 | Arm 1 spool kit | 33 | Plug | 56 | O-ring |
| 7 | Swing spool kit | 35 | Cap spool | 57 | Socket bolt |
| 9 | Boom 2 spool kit | 42 | Spring | 59 | Socket bolt |
| 10 | Travel straight spool kit | 43 | Poppet | 64 | Socket bolt |
| 11 | Option spool kit | 44 | Name plate | 66 | Spring washer |
| 13 | Swing priority spool kit | 45 | Rivet | 67 | BC plug assy |
| 15 | BC2 spool kit | 51 | O-ring | 68 | Opt stroke limit plug kit 1 |
| 16 | Holding valve assy | 52 | O-ring | | |
| 21 | Port relief valve assy | 53 | O-ring | | |

STRUCTURE (4/5)

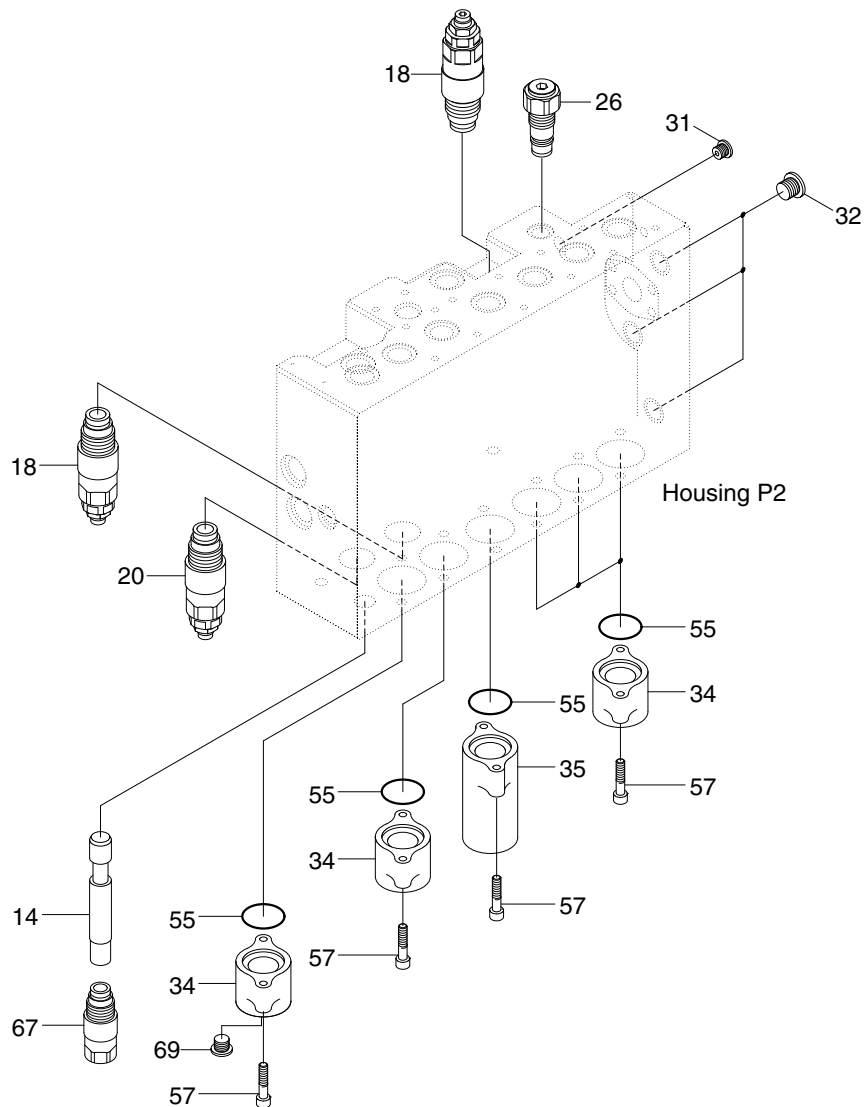

- | | | | | | |
|----|--------------------------|----|-----------|----|-----------------------------|
| 14 | BC1 spool kit | 31 | Plug | 55 | O-ring |
| 18 | Port relief valve assy | 32 | Plug | 57 | Socket bolt |
| 20 | Port relief valve assy | 34 | Spool cap | 67 | BC plug assy |
| 26 | Orifice signal plug assy | 35 | Spool cap | 69 | Opt stroke limit plug kit 2 |

220S8MC07

STRUCTURE (5/5)

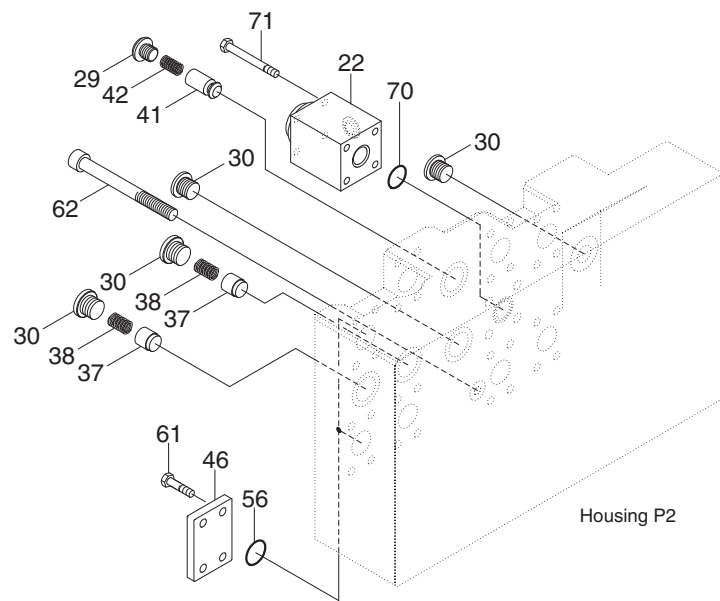

220S8MC08

22	Swing logic valve assy	41	Poppet	62	Socket bolt
29	Plug	42	Spring	70	O-ring
30	Load check valve	46	Port plug flange	71	Socket bolt
37	L/C poppet 1	56	O-ring		
38	L/C spring 1	61	Socket bolt		

3. DISASSEMBLY AND ASSEMBLY

1) GENERAL PRECAUTIONS

- (1) All hydraulic components are manufactured to a high precision. Consequently, before disassembling and assembling them, it is essential to select an especially clean place.
In handling a control valve, pay full attention to prevent dust, sand, etc. from entering into it.
- (2) When a control valve is to be removed from the machine, apply caps and masking seals to all ports. Before disassembling the valve, recheck that these caps and masking seals are fitted completely, and then clean the outside of the assembly. Use a proper bench for working. Spread paper or a rubber mat on the bench, and disassemble the valve on it.
- (3) Support the body section carefully when carrying or transferring the control valve. Do not lift by the exposed spool, end cover section etc.
- (4) After disassembling and assembling of the component it is desired to carry out various tests (for the relief characteristics, leakage, flow resistance, etc.), but hydraulic test equipment is necessary for these tests. Therefore, even when its disassembling can be carried out technically, do not disassemble such components that cannot be tested, adjusted, and so on. Additionally one should always prepare clean cleaning oil, hydraulic oil, grease, etc. beforehand.

2) TOOLS

Before disassembling the control valve, prepare the following tools beforehand.

Name of tool	Quantity	Size (mm)
Torque wrench	1	-
Extension bar	1	-
Hexagon bit socket	Each 1	6, 8, 10
Hex socket	1	36
Spanner	Each 1	32, 34, 38
Loctite #262	1	-

3) DISASSEMBLY

The figure in () shown after the part name in explanation sentence shows its number in the construction figures (8-31)

(1) Place main control valve on working bench

※ Disassemble it in clean place and pay attention not to damage flange faces and plate faces.

(2) Disassembling of orifice signal plug

- ① Loosen and remove orifice signal plug (25).



(3) Disassembling of main spool assy 1 (Pilot cover B side) (Travel R/L (3), Swing (7), Boom 2 (9), Arm regen (12), Arm 2 (8), Bucket (6), Option (11))

- ① Loosen the hexagon socket head bolts (45) 2EA and remove the pilot cover B (33) and O-ring (43).
[Hexagon key wrench 6 mm]

- ② Pull out the main spool, spring, spring seat stopper and spacer bolt in the spool assembly condition from the housing P1 & P2.



**(4) Disassembling of main spool assy 2 (Pilot cover B side)
(Boom 1 (5), Arm 1 (4))**

- ① Loosen the hexagon socket head bolts (47) 5EA and remove the O-ring (44) and holding valve block assy (16)
[Hexagon key wrench : 6 mm]
- ② Pull out the main spool, spring, spring seat stopper and spacer bolt in the spool assembly condition from the housing P1 & P2.

※ When you disassemble holding valve block assy, pay attention not to miss the pilot poppet.



220S8MC13

**(5) Disassembling of bypass cut spool (=BC)
(Bucket BC (14), Option BC (15))**

- ① Loosen bypass cut plug assy
[36mm socket wrench]
 - ② Pull out the bypass cut spool
- ※ Option BC spool (14) and bucket BC spool (15) are different lengths. So when you reassemble, be careful of length. (length : option BC > bucket BC)



220S8MC14

(6) Disassembling of pilot cover (Bucket stroke limiter)

- ① Loosen the hexagon socket head bolts (45) 2EA.
[Hexagon key wrench 6 mm]
- ② Remove the pilot cover (34) and O-ring (43).

(7) Disassembling of swing priority spool & pilot cover A
(Travel R/L (3), Swing (7), Boom1 (5), Arm 1 (4), Bucket (6), Option (11), Boom2 (9), Arm 2 (8))

- ① Loosen the hexagon socket head bolts (45) 2EA and remove the pilot cover A (32) and O-ring (43).
- ② Pull out the swing priority spool (13).
- ③ Remove the pilot cover A (32).



(8) Disassembling of regen valve block assy

- ① Loosen the hexagon socket head bolts (46) 3EA.
[Hexagon key wrench 6 mm]
- ② Remove plug (551) or (552) and take out poppet (511) or (515, 516) and spring (521) or (523).
- ③ When you disassemble regen valve block assy, pay attention not to miss the piston and O-ring (43).



(9) Disassembling of main relief valve

- ① Loosen and remove the main relief valve (23).
[Spanner 32 mm]



(10) Disassembling of port relief valve (Except the option side)

- ① Loosen and remove the port relief valve (18).
[Spanner 34 mm]



**(11) Disassembling of port relief valve (Option side)
(1-stage (19), 2-stage (20))**

- ① Loosen and remove the port relief valve.
[Spanner 38 mm]



(12) Disassembling of logic valve
(Arm logic valve (22), Swing logic valve
(21))

- ① Loosen the hexagon socket head bolts
(56) 4EA and remove the logic valve.
[Hexagon key wrench 8 mm]

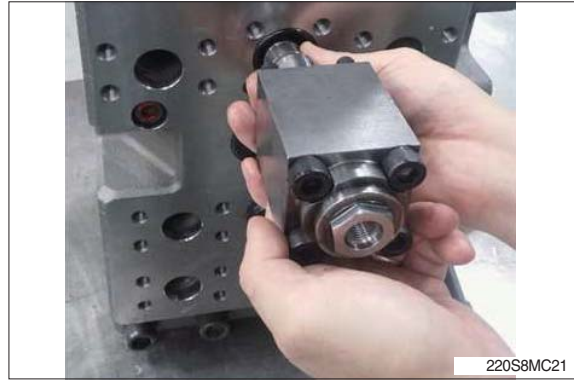

- ② Remove the swing logic poppet.



- ③ Remove the Arm logic poppet and spring
by same method.



**(13) Disassembling of check valve (Plug (27)
2EA)**

- ① Loosen the plug (27) and remove the poppet (37), spring (38).
[Hexagon key wrench 10 mm]



(14) Main spool disassembly

- ① Fix the spool to the dedicated jig and take it apart.
(Spacer bolt, spring, stopper, spring seat)
[Hexagon key wrench 8 mm]



(15) Disassembling of housing

① Loosen the hexagon socket head bolts
(49, 50) each 2EA, 8EA

※ Except when required specially, do not
disassemble housing P1&P2 for
sanitation.



(16) Inspection after disassembly

Clean all disassembled parts with clean mineral oil fully, and dry them with compressed air. Then, place them on clean papers or cloths for inspection.

① Control valve

- a. Check whole surfaces of all parts for burrs, scratches, notches and other defects.
- b. Confirm that the seal groove faces of the housing and the covers are smooth and free of dust, dent, rust etc.
- c. Correct dents and damages on check seat faces of housing, if any, by lapping.
- ※ Pay attention not to leave lapping agent in the housing.
- d. Confirm that all sliding and fitting parts can be moved manually and that all grooves and paths are free from foreign matter.
- e. If any spring is broken or deformed, replace it with new one.
- f. When a relief valve does not function properly, repair it, following its inspection procedures.
- g. Replace all the O-rings with new ones.

② Relief valve

- a. Confirm that all seat faces at ends of all poppets and seats are free of defects and are uniform contact faces.
- b. Confirm manually that main poppet and seat can slide lightly and smoothly.
- c. Confirm that outside face of main poppet and inside face of seat are free from scratches and so on.
- d. Confirm that orifices of the main poppet and seat section are not clogged with foreign matter.
- e. Replace all O-rings with new ones.
- f. When any light damage is found in above inspections, correct it by lapping.
- g. When any abnormal part is found, replace it with a relief valve assembly.

GROUP 5 SWING DEVICE (TYPE 1, 2)

1. REMOVAL AND INSTALL OF MOTOR

1) REMOVAL

- (1) Lower the work equipment to the ground and stop the engine.
- (2) Operate the control levers and pedals several times to release the remaining pressure in the hydraulic piping.
- (3) Loosen the breather slowly to release the pressure inside the hydraulic tank.

▲ Escaping fluid under pressure can penetrate the skin causing serious injury.

※ When pipes and hoses are disconnected, the oil inside the piping will flow out, so catch it in oil pan.

- (4) Disconnect hose assembly (2).
- (5) Disconnect pilot line hoses (3, 4, 5, 6, 7, 8).
- (6) Sling the swing motor assembly (1) and remove the swing motor mounting socket bolts (9).
 - Motor device weight : 61 kg (135 lb)
 - Tightening torque : 57.9 ± 5.8 kgf·m
(419 ± 42 lbf·ft)

- (7) Remove the swing motor assembly.

※ When removing the swing motor assembly, check that all the piping have been disconnected.

2) INSTALL

- (1) Carry out installation in the reverse order to removal.
- (2) Bleed the air from the swing motor.
 - ① Remove the air vent plug.
 - ② Pour in hydraulic oil until it overflows from the port.
 - ③ Tighten plug lightly.
 - ④ Start the engine, run at low idling and check oil come out from plug.
 - ⑤ Tighten plug fully.
- (3) Confirm the hydraulic oil level and check the hydraulic oil leak or not.

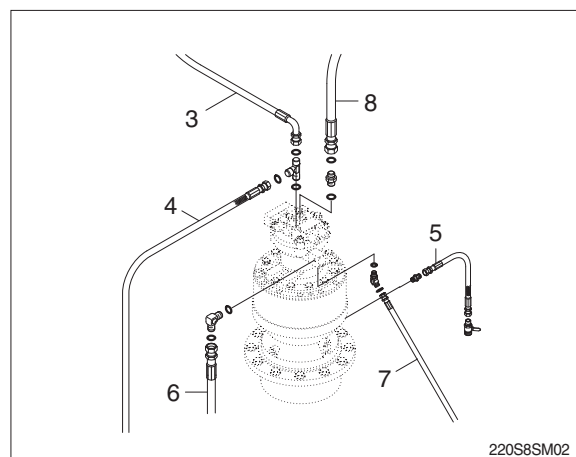
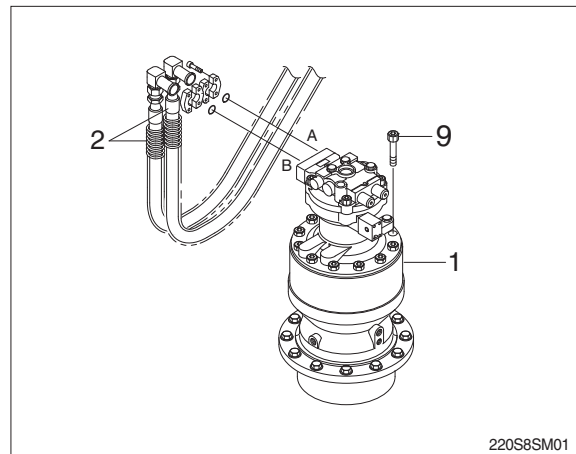

2. DISASSEMBLY AND ASSEMBLY OF SWING MOTOR

1) STRUCTURE

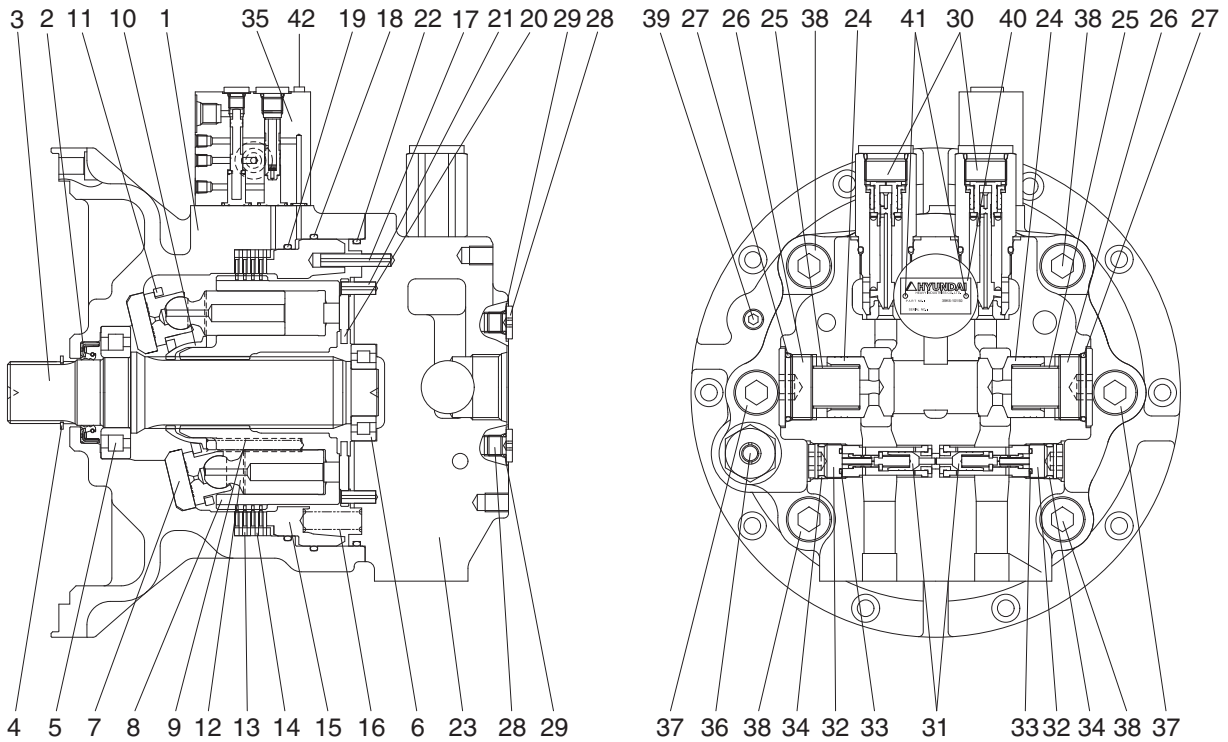

220S2SM02

- | | | | | | |
|----|----------------|----|----------------|----|-------------------------|
| 1 | Casing | 15 | Parking piston | 29 | O-ring |
| 2 | Oil seal | 16 | Spring | 30 | Relief valve assy |
| 3 | Shaft | 17 | Spring pin | 31 | Reactionless valve assy |
| 4 | Snap ring | 18 | O-ring | 32 | Plug |
| 5 | Roller bearing | 19 | O-ring | 33 | O-ring |
| 6 | Needle bearing | 20 | Valve plate | 34 | O-ring |
| 7 | Swash plate | 21 | Spring pin | 35 | Time delay valve assy |
| 8 | Cylinder block | 22 | O-ring | 36 | Level gauge |
| 9 | Spring | 23 | Valve casing | 37 | Socket bolt |
| 10 | Ball guide | 24 | Check valve | 38 | Socket bolt |
| 11 | Retainer plate | 25 | Spring | 39 | Plug |
| 12 | Piston assy | 26 | Plug | 40 | Name plate |
| 13 | Friction plate | 27 | O-ring | 41 | Rivet |
| 14 | Separate plate | 28 | Plug | 42 | Socket bolt |

2) DISASSEMBLY

(1) Disassemble drive shaft

- ① Unloosing socket bolt (time delay valve, 42) and disassemble time delay valve assy (35) from casing (1).



2209A8SM51

- ② Disassemble level gauge (36) from casing (1).



2209A8SM52

- ③ Hang valve casing (23) on hoist, unloose socket bolt (37, 38) and disassemble from casing (1).



2209A8SM53

- ④ Disassemble spring (16) and using a jig, disassemble parking piston (15) from casing (1).

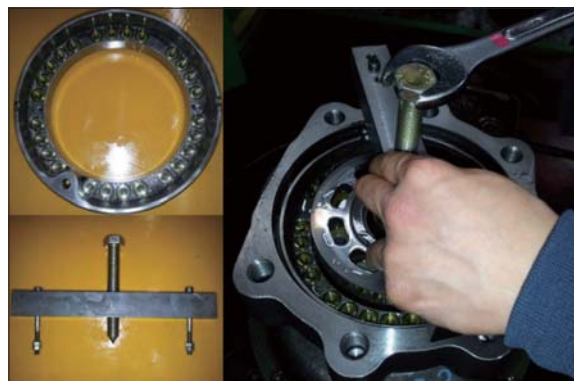

2209A8SM54

- ⑤ Disassemble respectively cylinder block sub (8), friction plate (13), separate plate (14) from casing (1).



2209A8SM55

- ⑥ Disassemble swash plate (7) from casing (1).



2209A8SM56

- ⑦ Using a plier jig, disassemble snap ring (4) from casing (1).



2209A8SM57

- ⑧ Disassemble shaft assy (3), oil seal (2) and O-ring (18, 22) from casing (1).



2209A8SM58

(2) Disassemble cylinder block sub

- ① Disassemble piston assy (12) from cylinder block (8).



- ② Disassemble ball guide (10) and spring (cylinder block, 9) from cylinder block (8).
 - Ball guide × 1EA
 - Spring × 9EA



(3) Disassemble valve casing sub

- ① Disassemble spring pin (17, 21), valve plate (20), O-ring (22) from valve casing (23).



- ② Using a torque wrench, disassemble relief valve (30) from valve casing (23).



- ③ Using a torque wrench, disassemble plug (32) from valve casing (23) and disassemble O-ring (33, 34) and reaction-less valve assy (31).



2209A8SM63

- ④ Using a torque wrench, disassemble check valve (24) from valve casing (23).



2209A8SM64

- ⑤ Disassemble plug (28), O-ring (29) from valve casing (23).



2209A8SM65

3) ASSEMBLING

(1) Assemble shaft sub

- ① Put roller bearing (3) on preheater and provide heat to inner race.
(Temperature in conveyor : 120°C for 3~5 minutes)



2209A8SM66

- ② Using a robot machine, assemble and press preheated roller bearing (3) into shaft (5).



2209A8SM67

(2) Assemble cylinder block sub

- ① Assemble 9 springs (cylinder block, 9) into cylinder block (8).
 - Spring × 9EA



2209A8SM68

- ② Assemble ball guide (10) into cylinder block (8).
 - Ball guide × 1EA



2209A8SM69

③ Assemble 9 piston assy (12) into retainer plate (11).

- Piston assy × 9EA
- Retainer plate × 1EA



2209A8SM70

④ Assemble parts of procedure ② and ③.



2209A8SM71

(3) Assemble valve casing sub

① Assemble make up check valve sub

Assemble check valve (24), O-ring (27), plug (26) in that order and then screw it torque wrench.

- Make up check valve × 2EA
- Spring × 2EA
- Plug × 2EA
- O-ring × 2EA



2209A8SM72

② Assemble reactionless valve assy

Assemble reactionless valve assy (31), plug (32), O-ring (33, 34) in that order and then screw it a torque wrench.

- Reactionless valve assy (31) × 2EA
- Plug (32) × 2EA
- O-ring (33, 34) × 2EA



2209A8SM73

- ③ Using a torque wrench, assemble relief valve (30) 2 sets into valve casing (23).
- Relief valve (30) × 2EA



2209A8SM74

- ④ Assemble plug (28) and O-ring (27) into valve casing (23).
- Plug (28) × 3EA
 - O-ring (27) × 3EA



2209A8SM75

- ⑤ Assemble needle bearing (6) into valve casing (23) and assemble spring pin (17, 21) into valve casing (23).
- Needle bearing (6) × 1EA
 - Spring pin (17, 21) × 1EA



2209A8SM76

- ⑥ Apply some grease valve plate (20) and assemble it into valve casing (23).



2209A8SM77

(4) Assemble drive shaft sub

- ① Using a jig, assemble oil sealing (2) into casing (1).



2209A8SM78

- ② Fit shaft sub (shaft+roller bearing) into casing (1).



2209A8SM79

- ③ Using a plier jig, assemble snap ring (4) to shaft (3).
 - Snap ring × 1EA



2209A8SM80

- ④ Apply some grease swash plate (7) and assemble it into casing (1).
 - Swash plate × 1EA



2209A8SM81

⑤ Insert O-ring (18, 19) into casing (1).

- O-ring (18) × 1EA
- O-ring (19) × 1EA



2209A8SM82

⑥ Assemble cylinder block (8) into casing (1).



2209A8SM83

⑦ Assemble separate plate (14) and friction plate (13) 4 sets into casing (1) and fit parking piston (15) into casing (1) by a jig or a press.

- Separate plate × 4EA
- Friction plate × 4EA
- Parking piston × 1EA



2209A8SM84

⑧ Assemble spring (parking piston, 16) into parking piston (15).

- Spring × 26EA



2209A8SM85

- ⑨ Lift up valve casing (23) on casing (1) by a crane and assemble it with socket bolts (37, 38).



2209A8SM86

- ⑩ Assemble level gauge (36) and plug (39) into casing (1).



2209A8SM87

- ⑪ Assemble time delay valve assy (35) into valve casing (23) with socket bolt (42).
- Time delay valve × 1EA
 - Socket bolt × 3EA



2209A8SM88

⑫ **Air pressing test**

Be sure of leakage, after press air into assembled motor and put it in water for 1 minute (pressure : 2 kgf/cm²).



2209A8SM89

⑬ **Leakage check**

Place motor on a bench tester and after cleaning motor by color check No.1, paint No.3 and be sure of leakage.



2209A8SM90

⑭ **Mount test bench**

Mounting motor a test bench, test the availability of each part.



2209A8SM91

3. REMOVAL AND INSTALL OF REDUCTION GEAR

1) REMOVAL

- (1) Remove the swing motor assembly.
For details, see removal of swing motor assembly.
- (2) Sling reduction gear assembly (1) and remove dowel pin (3) and mounting bolts (2).
- (3) Remove the reduction gear assembly.
 - Reduction gear device weight : 75 kg
(165 lb)



2) INSTALL

- (1) Carry out installation in the reverse order to removal.
 - Tightening torque : $57.9 \pm 5.8 \text{ kgf} \cdot \text{m}$
($419 \pm 42 \text{ lbf} \cdot \text{ft}$)

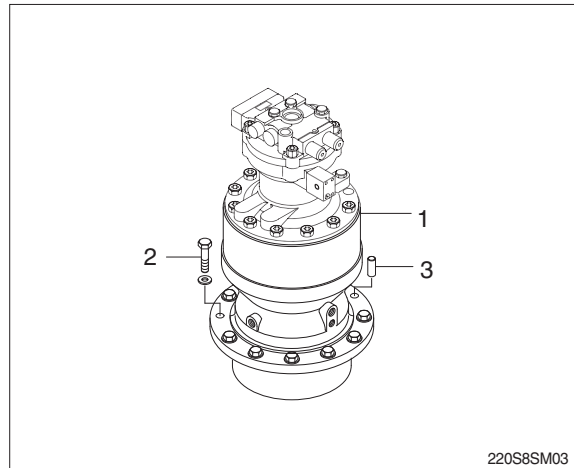

3. DISASSEMBLY AND ASSEMBLY OF REDUCTION GEAR

1) STRUCTURE

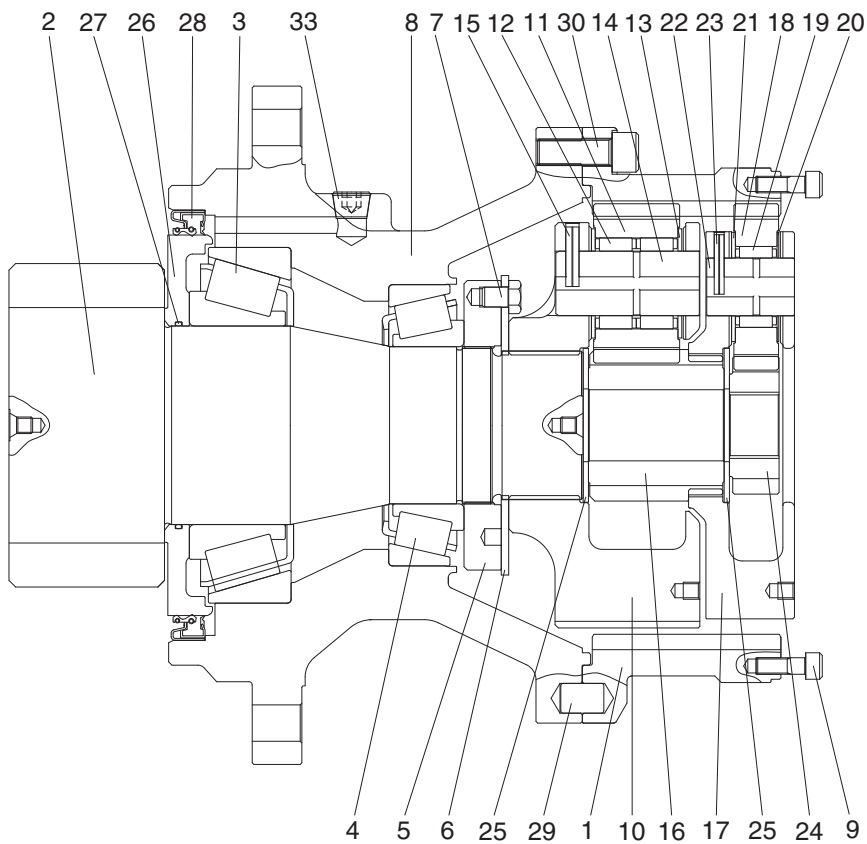

220L2SM03

- | | | | | | |
|----|---------------|----|------------------|----|-----------------|
| 1 | Ring gear | 11 | Planetary gear 2 | 21 | Thrust washer 1 |
| 2 | Drive shaft | 12 | Needle bearing 2 | 22 | Carrier pin 1 |
| 3 | Taper bearing | 13 | Thrust washer 2 | 23 | Spring pin 1 |
| 4 | Taper bearing | 14 | Carrier pin 2 | 24 | Sun gear 1 |
| 5 | Ring nut | 15 | Spring pin 2 | 25 | Thrust plate |
| 6 | Lock plate | 16 | Sun gear 2 | 26 | Sleeve |
| 7 | Hexagon bolt | 17 | Carrier 1 | 27 | O-ring |
| 8 | Casing | 18 | Planetary gear 1 | 29 | Parallel pin |
| 9 | Socket bolt | 19 | Needle bearing 1 | 30 | Socket bolt |
| 10 | Carrier 2 | 20 | Thrust washer 1 | 33 | Plug |

2) DISASSEMBLY

(1) Preparation

- ① The reduction gear removed from machine is usually covered with mud.
Wash out side of reduction gear and dry it.
 - ② Setting reduction gear on work stand for disassembling.
 - ③ Mark for mating
Put marks on each mating parts when disassembling so as to reassemble correctly as before.
- ▲ Take great care not to pinch your hand between parts while disassembling not let fall parts on your foot while lifting them.

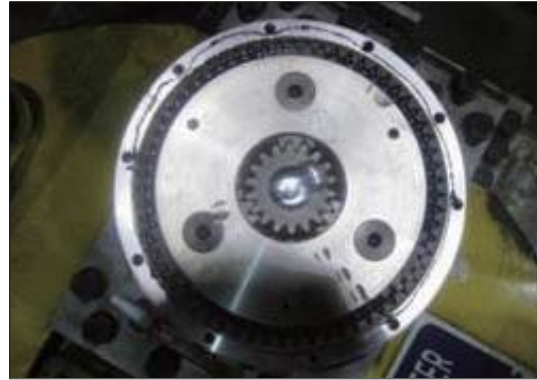

2209A8SM01

(2) Disassembly

- ① Remove every "Socket bolt (M10)" that secure swing motor and reduction gear.
- ② Removing carrier sub assy & sun gear
 - a. Removing No.1 sun gear from No.1 carrier sub assy.
※ Be sure maintaining it vertical with ground when disassembling No.1 sun gear.



2209A8SM02

- b. Removing No.1 carrier sub assy screwing I-bolt to tab hole (M10) in No.1 carrier.
Lifting it gradually maintaining it vertical with ground.
※ It's impossible to disassemble No.1 spring pin. If No.1 spring pin has problem, change whole No.1 carrier sub assy.



2209A8SM03

- c. Removing No.2 sun gear from No.2 carrier sub assy.
※ Be sure maintaining it vertical with ground when disassembling No.2 sun gear.



2209A8SM04

- d. Removing No.2 carrier sub assy screwing I-bolt to tab hole (M10) in No.2 carrier.
Lifting it gradually maintaining it vertical with ground.
※ It's impossible to disassemble No.2 spring pin. If No.2 spring pin has problem, change whole No.2 carrier sub assy.



2209A8SM05

③ Removing ring gear

- After unscrewing every socket bolt (M16), remove ring gear from casing.
※ Because of liquid gaskets between ring gear and casing, put sharp punch between ring gear and casing and tapping it to remove them.



2209A8SM06

④ Removing drive shaft sub assy

- a. Unscrew every hex head bolt (M12) to remove lock plate.

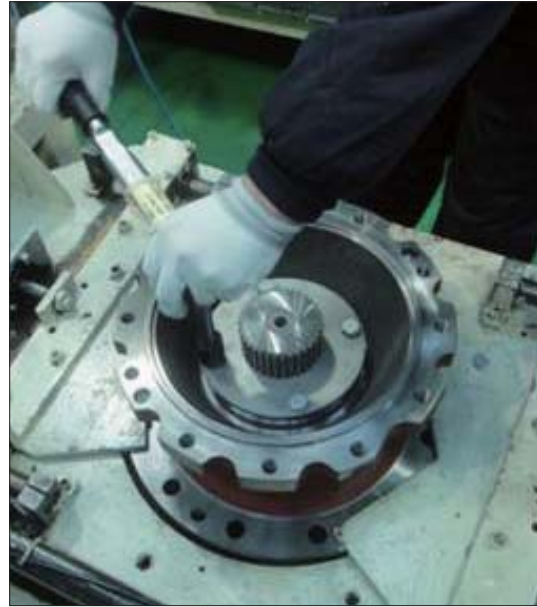

2209A8SM07

- b. Rolling ring nut for removing them from drive shaft sub assy.

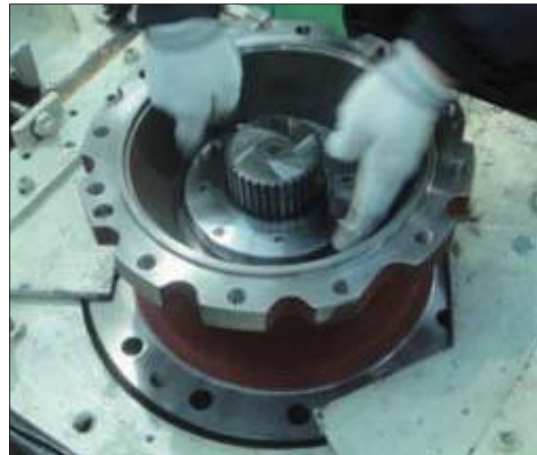

2209A8SM08

- ※ Use special tool to roll ring nut to counter clockwise.

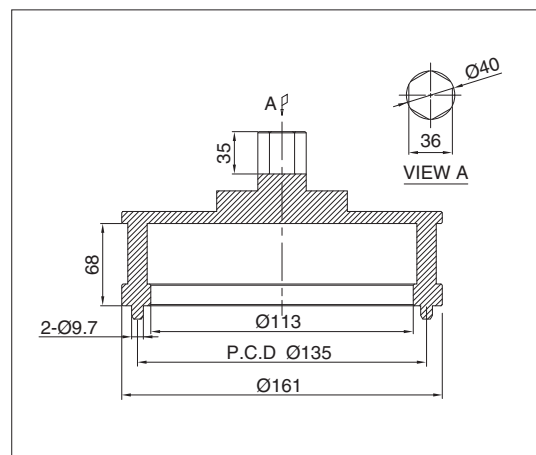

220L8SM01

- c. Remove drive shaft sub assy from casing.
※ Set a rack for flange of casing, and remove drive shaft sub assy from casing by using press.



2209A8SM09

- d. Remove oil seal & taper bearing (small) from casing.
※ Do not re-use oil seal. It is impossible to disassemble drive shaft sub assy.



2209A8SM10



2209A8SM11

4. ASSEMBLY REDUCTION UNIT

1) GENERAL NOTES

- (1) Clean every part by kerosene and dry them in a cool and dry place.
- (2) Loctite on surface must be removed by solvent.
- (3) Check every part for any abnormal.
- (4) Each hexagon socket head bolt should be used with loctite #242 applied on its threads.
- (5) Apply gear oil slightly on each part before assembling.

▲ Take great care not to pinch your hand between parts or tools while assembling nor let fall parts on your foot while lifting them.

Inspection before assembling.

Thrust washer

- Check the seizure, abnormal wear or uneven wear.
- Check the unallowable wear.

Gear

- Check the pitting or seizure on tooth surface.
- Check the cracks on the root of tooth.

Bearing

- Rotate it by hands to check such noise or uneven rotation.

2) ASSEMBLING NO.1 CARRIER SUB ASSY

- (1) Put thrust plate firmly in No.1 carrier.
- (2) After assembling No.1 needle bearing to No.1 planetary gear, put a pair of No.1 thrust washer on both sides of bearing and install them to No.1 carrier.



2209A8SM12



2209A8SM13

- (3) Make of spring pin hole No.1 pin and No.1 carrier of spring pin hole in line, press No.1 spring pin into the holes.
 Make No.1 spring pin hole head for No.1 planetary gear.



2209A8SM14

- (4) Caulk carrier holes to make No.1 spring pin settle down stably.



2209A8SM15

- ※ Refer to “Caulking details”
 Use paint marker for marking after caulking.

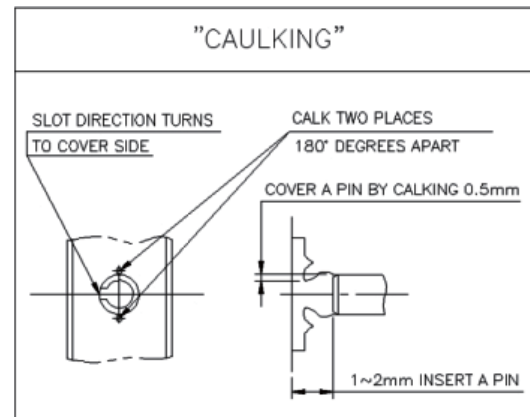

2209A8SM16

2) ASSEMBLING NO.2 CARRIER SUB ASSY

(1) Put thrust plate in firmly No.2 carrier.



2209A8SM17

(2) After assembling No.2 needle bearing to No.2 planetary gear, put 2 pieces of No.2 thrust washer on both sides of bearing and install them to No.2 carrier.



2209A8SM18

(3) Align No.2 spring pin hole and No.2 carrier spring pin hole, put No.2 spring pin into the holes.
Make No.2 spring pin cutting line face to No.2 planetary gear.



2209A8SM19

(4) Caulk carrier holes to make No.2 spring pin settle down stably.

※ Refer to "Caulking details"

Use paint marker for marking after caulking.

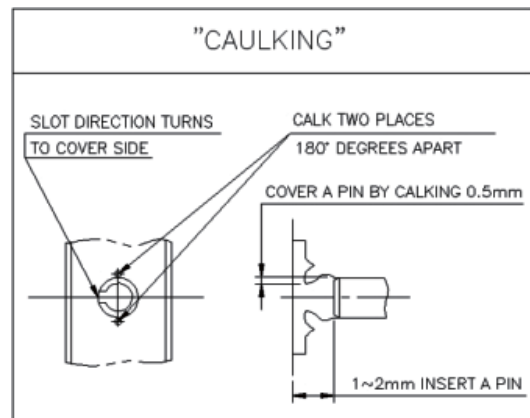

2209A8SM20

3) ASSEMBLING PINION GEAR SUB ASSY

- (1) Prepare drive shaft pinion gear vertical with ground.



2209A8SM21

- (2) Fully apply grease (albania EP02) to O-ring groove of sleeve.
※ Be sure to maintain it vertical with ground when assembling it.
- (3) Put O-ring into O-ring groove of sleeve.
Fully apply grease on O-ring.

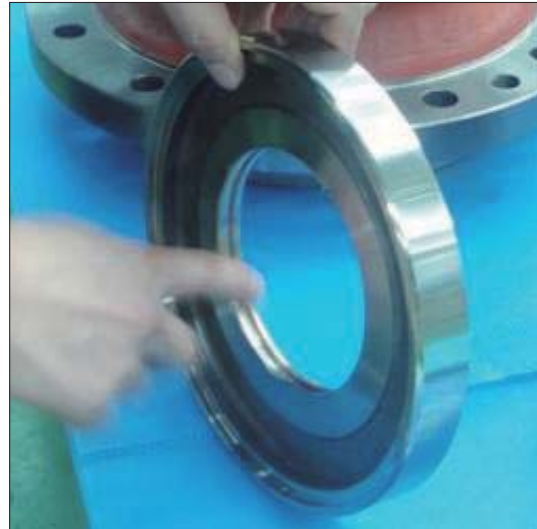

2209A8SM22

- (4) Assemble taper bearing and sleeve into drive shaft using press jig.
Use special jig for pressing. Leave no space between sleeve and taper bearing.



2209A8SM23



2209A8SM24

4) ASSEMBLING BEARING CUP & OIL SEAL (PRESSING)

- (1) Put top, bottom bearing cup into casing.
Use special jig for pressing. Pay attention to foreign materials while assembling bearing cup.
- ※ Flip over casing to assemble oil seal.

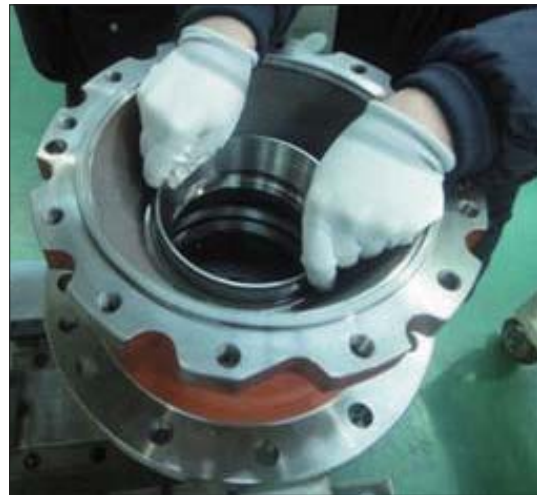

2209A8SM25



2209A8SM26

- (2) Assemble oil seal to casing.
Use special jig for pressing. Pay attention to direction of dust seal and dent.



2209A8SM27

※ WHILE ASSEMBLING OIL SEAL

1. Be sure to set dust seal to gear oil.
2. Before assembling, charge enough grease in oil seal.
3. Before assembling, apply enough grease inside and outside of oil seal.



2209A8SM28

5) ASSEMBLING SHAFT SUB ASSY & RING NUT

- (1) After assembling casing & drive shaft sub assy, flip it over.



2209A8SM29

- (2) Put drive shaft sub assy into casing.
※ Be sure to maintain it vertical with ground when assembling it.



2209A8SM30

- (3) Put taper bearing into it.
Rotate bearing by hands for checking after assembly.



2209A8SM31

- (4) Put ring nut into drive shaft sub assy by using special jig.

The tightening torque (M95) = 3.5 ± 0.4 kgf·m
(25.3 ± 2.9 lbf·ft)



2209A8SM32

- ※ Apply enough loctite #242 before screwing bolts.



2209A8SM33

- (5) Align bolt screw of ring nut with lock plate's hole.

In case of misalign between bolt screw ring nut and lock plate's hole, put lock plate as near as possible to hole of bolt screw of ring nut and make it in line by increasing tightening torque.



2209A8SM34



2209A8SM35

- (6) Screw 4 bolts (M12×16) to connect ring nut and lock plate by using torque wrench.

Bolt (M12, 4EA) = 10.9T

The tightening torque = 8.8 ± 0.9 kgf·m
(63.7 ± 6.5 lbf·ft)

- ※ Apply enough loctite #242 before screwing bolts.

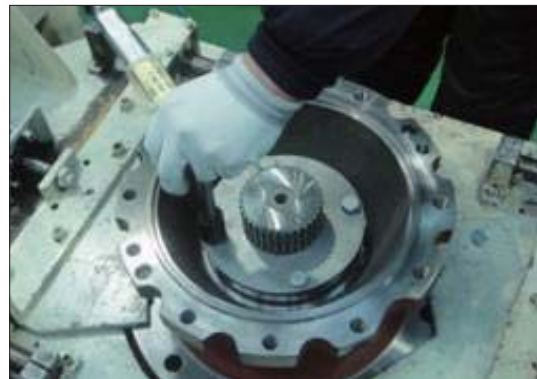

2209A8SM36

- (7) Use paint marker for checking surplus parts after assembling.



2209A8SM37

6) ASSEMBLING RING GEAR

- (1) Apply loctite #515 bottom of casing sub assy contacting with ring gear without disconnection.



2209A8SM38

Refer to loctite detail.

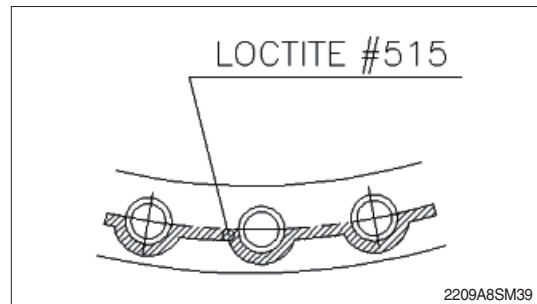

2209A8SM39

- (2) Put parallel pin into hole of casing sub assy.
Mark parallel pin position using paint marker.



2209A8SM40

- (3) Align ring gear with parallel pin to put them into casing sub assy.
※ Be sure to maintain them vertical with ground while using press.



2209A8SM41

- (4) Screw 12 bolts (M16×45) to connect casing sub assy and ring gear (01) by using torque wrench.

Bolt (M16, 12EA) = 12.9T

The tightening torque = 27 ± 2.7 kgf-m
(195 ± 19.5 lbf-ft)

- ※ Apply enough loctite #242 before screwing bolts.



2209A8SM42

- (5) Use paint marker for checking surplus parts after assembling.



2209A8SM43



2209A8SM44

7) ASSEMBLING CARRIER SUB ASSY & SUN GEAR

- (1) Put No.2 carrier sub assy along spline of drive shaft spline.
- Screw M10 I-bolt to No.2 carrier sub assy.
 - Lifting up No.2 carrier sub assy and align planetary gear and tooth of ring gear by rotating planetary gear by hands.
 - Rotate No.2 carrier sub assy by hands to fit No.2 carrier sub assy into drive shaft spline.



2209A8SM45

- (2) Put No.2 sun gear into No.2 carrier sub assy.



2209A8SM46

- (3) Put No.1 carrier sub assy into No.2 sun gear along spline.
- Screw M10 I-bolt to No.1 carrier sub assy.
 - Lifting up No.1 carrier sub assy and align planetary gear and tooth of ring gear by rotating planetary gear by hands.
 - Rotate No.1 carrier sub assy by hands to fit No.1 carrier into No.2 sun gear spline.



2209A8SM47

- (4) Put No.1 sun gear into No.1 carrier sub assy. Be sure to maintain it vertical with ground. And align with No.1 planetary gear spline.
- (5) Rotate No.1 carrier sub assy by hands to check noise.

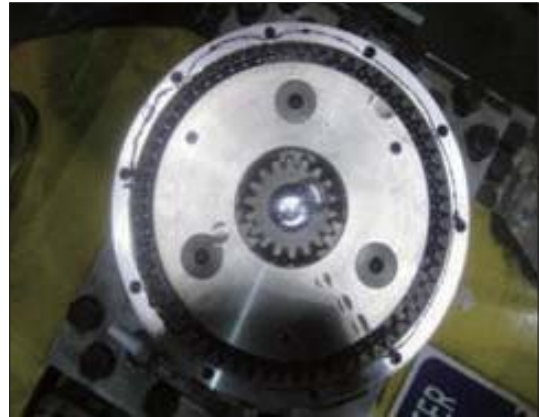

2209A8SM48

8) MEASURING CLEARANCE & ASSEMBLING NAME PLATE

- (1) Check the clearance between ring gear and No.1 sun gear using a tool with dial gauge.
- Check the clearance
Dial gauge = -0.3 ~ +2.95



2209A8SM49

GROUP 6 TRAVEL DEVICE (TYPE 1, 2)

1. REMOVAL AND INSTALL

1) REMOVAL

- (1) Swing the work equipment 90 ° and lower it completely to the ground.
- (2) Operate the control levers and pedals several times to release the remaining pressure in the hydraulic piping.
- (3) Loosen the breather slowly to release the pressure inside the hydraulic tank.

▲ Escaping fluid under pressure can penetrate the skin causing serious injury.

※ When pipes and hoses are disconnected, the oil inside the piping will flow out, so catch it in oil pan.

(4) Remove the track shoe assembly.
For details, see **removal of track shoe assembly**.

(5) Remove the cover.

(6) Remove the hoses.

※ Fit blind plugs to the disconnected hoses.

(7) Remove the bolts and the sprocket.

(8) Sling travel device assembly (1).

(9) Remove the mounting bolts (2), then remove the travel device assembly.

· Weight : 305 kg (670 lb)

· Tightening torque : 23 ± 2.5 kgf·m
(166 ± 18.1 lbf·ft)

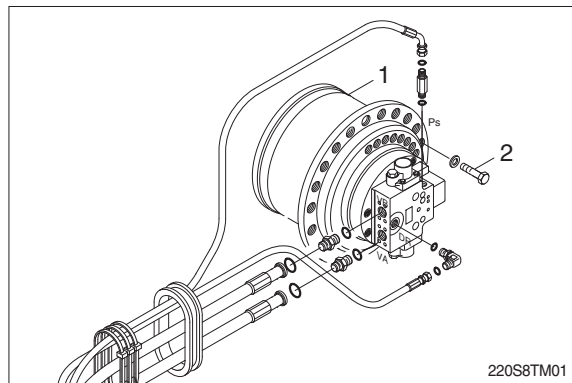

2) INSTALL

(1) Carry out installation in the reverse order to removal.

(2) Bleed the air from the travel motor.

① Remove the air vent plug.

② Pour in hydraulic oil until it overflows from the port.

③ Tighten plug lightly.

④ Start the engine, run at low idling, and check oil come out from plug.

⑤ Tighten plug fully.

(3) Confirm the hydraulic oil level and check the hydraulic oil leak or not.

2. TRAVEL MOTOR

1) STRUCTURE

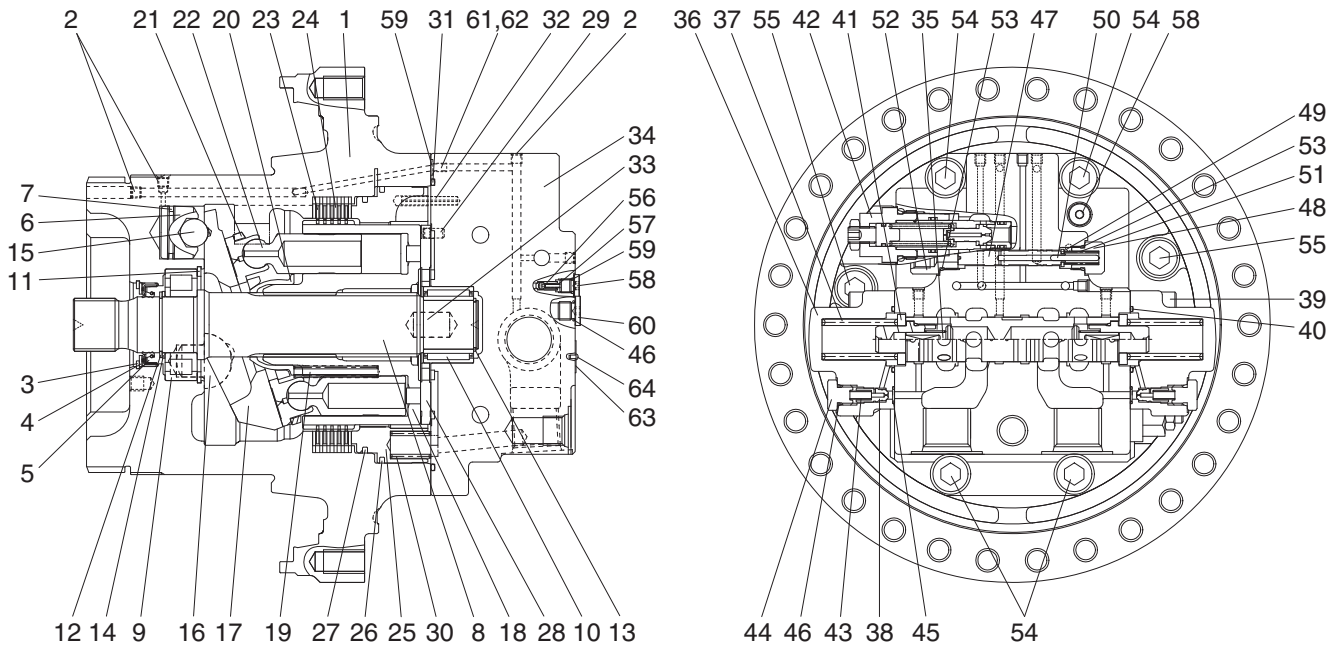

2209A2TM21

1	Casing	23	Friction plate	44	Plug
2	Plug	24	Separated plate	45	O-ring
3	Oil seal	25	Parking piston	46	O-ring
4	Thrust plate	26	D-ring	47	Spool
5	Snap ring	27	D-ring	48	Plug
6	Piston	28	Valve plate	49	Spring seat
7	Piston seal	29	Parallel pin	50	Parallel pin
8	Shaft	30	Spring	51	Spring
9	Cylinder roller bearing	31	O-ring	52	Connector
10	Needle bearing	32	Spring pin	53	O-ring
11	Snap ring	33	Parallel pin	54	Hexagon socket head bolt
12	Snap ring	34	Rear cover	55	Hexagon socket head bolt
13	Snap ring	35	Main spool assy	56	Check valve
14	Thrust plate	36	Cover	57	Spring
15	Steel ball	37	Spring	58	Plug
16	Pivot	38	Restrictor	59	O-ring
17	Swash plate	39	Hexagon socket head bolt	60	Plug
18	Cylinder block	40	O-ring	61	Restrictor
19	Spring	41	Spring seat	62	Restrictor
20	Ball guide	42	Relief valve assy	63	Name plate
21	Retainer plate	43	Spring	64	Rivet
22	Piston assy				

2) TOOLS AND TIGHTENING TORQUE

(1) Tools

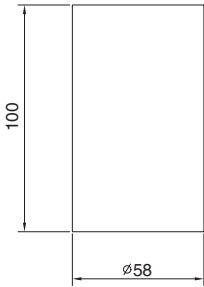
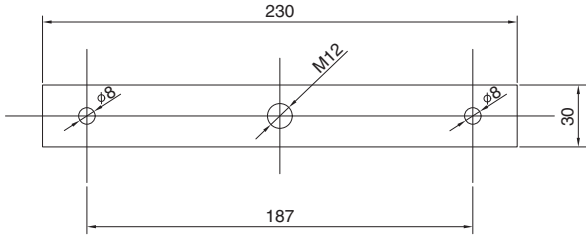
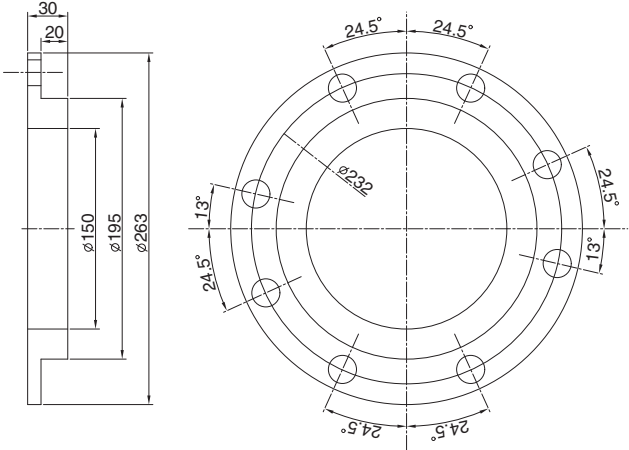
Tool name	Remark
Hexagon wrench	Width across flat 5, 6, 8, 10, 14 mm
Snap ring prier	For shaft $\varnothing 60\sim 80$ mm
Snap ring prier	For bore $\varnothing 32\sim 58$ mm
Plastic hammer	1 piece
Screw driver	Minus (-), medium size, 2 pieces
Torque wrench	10 kgf·m (72.3 lbf·ft), 33 kgf·m (238.6 lbf·ft), 45 kgf·m (325.4 lbf·ft)
Gig for inserting oil seal	 <p style="text-align: right;">25098TM31</p>
Gig for inserting parking piston (M10×100 bolt 2EA, M12×100 bolt 1EA)	 <p style="text-align: right;">25098TM32</p>
Gig for pulling out brake piston	 <p style="text-align: right;">25098TM33</p>

(2) Tightening torque

Item	Name	Size	Torque	
			kgf · m	lbf · ft
2	Plug	NPTF 1/16	1.1±0.1	7.9±0.72
39	Hexagon socket head bolt	M12	1.0±1.0	72.3±7.2
42	Relief valve	1 5/16	34±3.4	246±24.6
44	Plug	PF 1/4	2.8±0.3	20.3±2.17
48	Plug	PF 3/8	5.5±0.5	39.8±3.6
52	Connector	PF 3/8	5.5±0.5	39.8±3.6
54	Hexagon socket head bolt	M18	38±3.8	275±27.5
55	Hexagon socket head bolt	M18	38±3.8	275±27.5
58	Plug	PF 1/8	1.5±0.1	10.8±0.72
60	Plug	PF 1/4	3±0.3	21.7±2.17

3. DISASSEMBLING

1) GENERAL INSTRUCTIONS

- ▲ Combustibles such as white kerosene are used for washing parts.**
These combustibles are easily ignited, and could result in fire or injury.
Be very careful when using.
 - ▲ Internal parts are coated with hydraulic fluid during disassembling and are slippery.**
If a part slips out of your hand and falls, it could result in bodily injury or could damage the park.
Be very careful when handling.
- (1) Generally, hydraulic equipment is precisely manufactured and clearances between each parts are very narrow. Therefore, disassembling and assembling works should be performed on the clean place where dusts hardly gather. Tools and kerosene to wash parts should also be clean and handled with great care.
 - (2) When motor is removed from the host machine, wash around the ports sufficiently and put the plugs so that no dust and/or water may invade. Take off these plugs just before the piping works when re-attach it to the host machine.
 - (3) Before disassembling, review the sectional drawing and prepare the required parts, depending on the purpose and the range of disassembling.
Seals, O-rings, etc., if once disassembled, are not reusable.
There are some parts that should be replaced as a subassembly.
Consult with the parts manual in advance.
 - (4) The piston can be inserted to whichever cylinder block for the initial assembling.
However, their combination should not be changed if they are once used. To reuse them, put the matching mark on both pistons and cylinder block before disassembling.
- ▲ Take great care not to pinch your hand between parts while disassembling nor let fall parts on your foot while lifting them.**

2) DISASSEMBLING TRAVEL MOTOR

- (1) Disassemble the wrench bolt (39) to tighten the spool cover (36) and rear cover (34) by using the L-wrench or impact wrench and then disassemble the spring (37), spring seat (41) and main spool assy (35) in order.

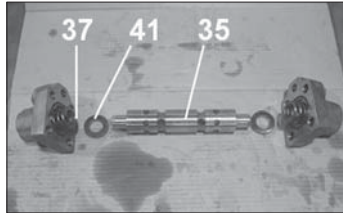

25098TM034

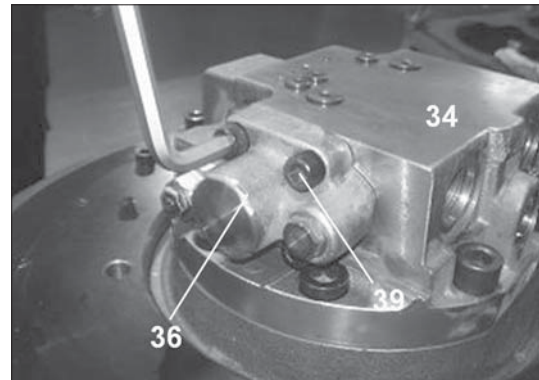

25098TM035

- (2) Disassemble the wrench bolt (54, 55) to tighten the casing (1) and rear cover (34) by using the L-wrench or impact wrench.

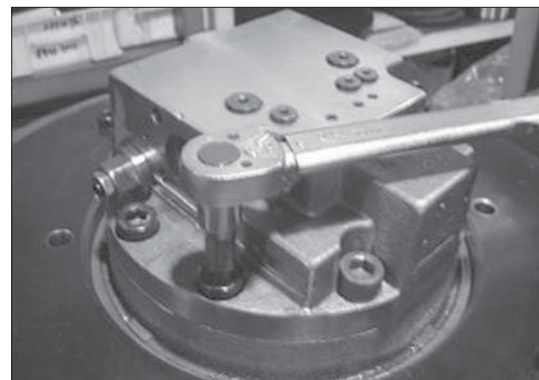

25098TM036

- (3) Separate the casing (1) and rear cover (34).

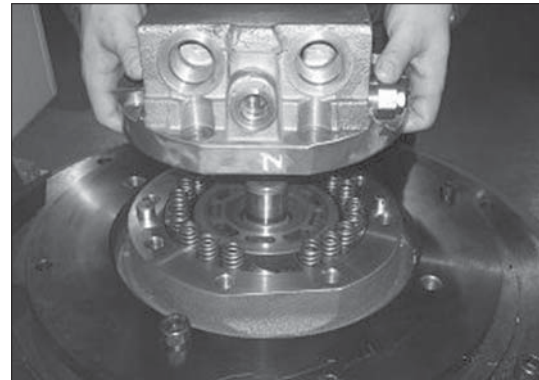

25098TM037

- (4) Disassemble the brake spring (30, 18EA) from the piston.

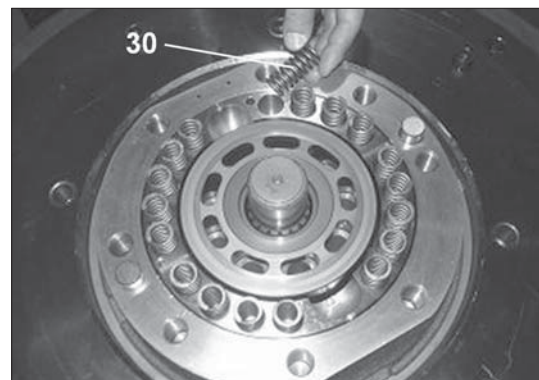

25098TM118

- (5) Disassemble the parking piston (25) by using the jig for disassembling parking piston.

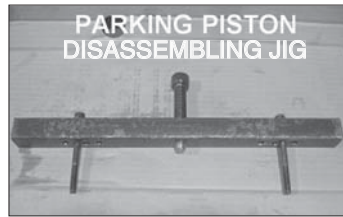

25098TM039

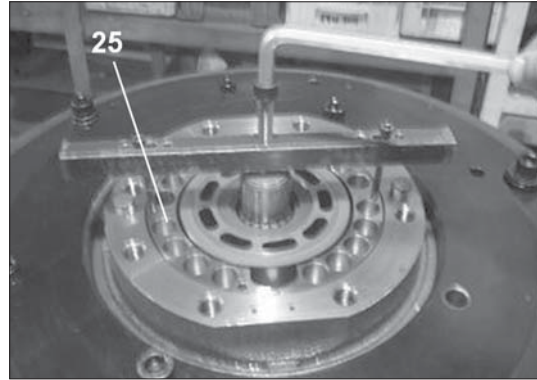

25098TM040

- (6) Disassemble the separated plate (24, 5EA) and friction plate (23, 4EA) from the casing.

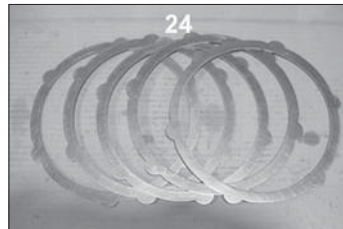

25098TM041

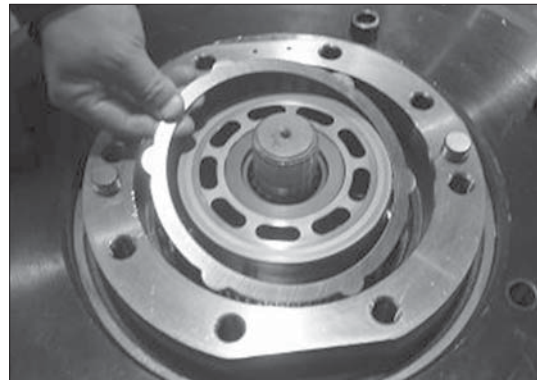

25098TM042

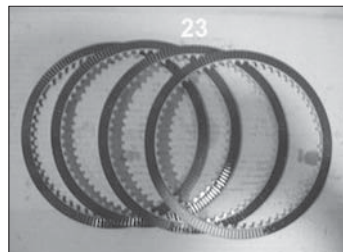

25098TM043

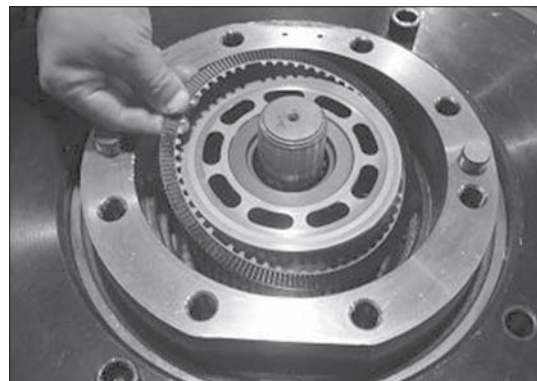

25098TM044

- (7) Turn the casing (1) horizontal by using the assemble truck and disassemble the cylinder block kit form the casing (1).

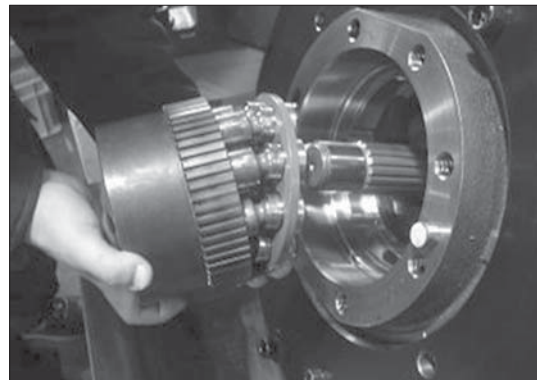

25098TM045

(8) Disassemble the cylinder block (18), retainer plate (21), piston assy (22), ball guide (20) and spring (19) from the cylinder block kit.



25098TM046

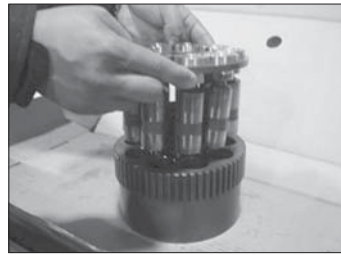

25098TM047

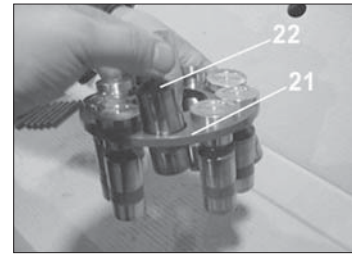

25098TM048

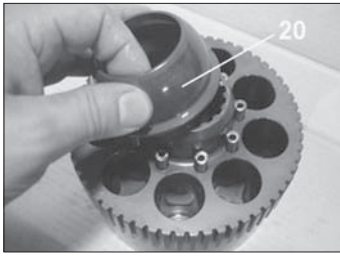

25098TM049

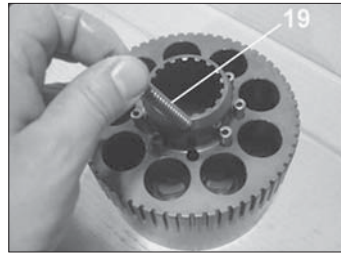

25098TM050

(9) Disassemble the swash plate (17) from the casing.



25098TM051

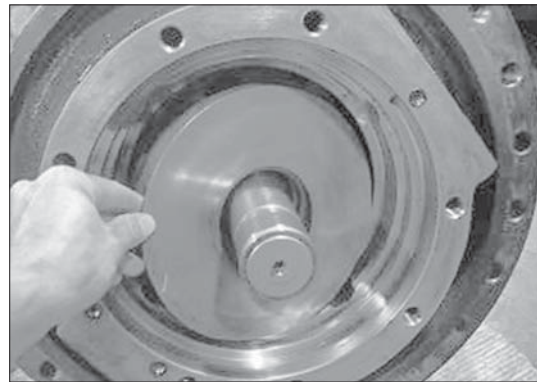

25098TM052

(10) Disassemble the steel ball (15) and swash piston (6) from the casing.

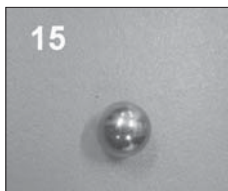

25098TM053

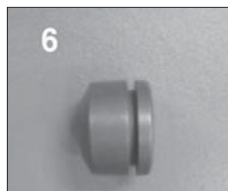

25098TM054



25098TM055

(11) Disassemble the pivot (16, 2EA) from the casing.

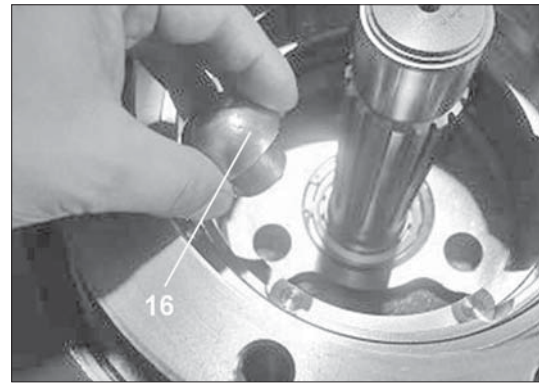

25098TM056

(12) Disassemble the snap ring (11) from the shaft (8) with the pryer for retaining ring.

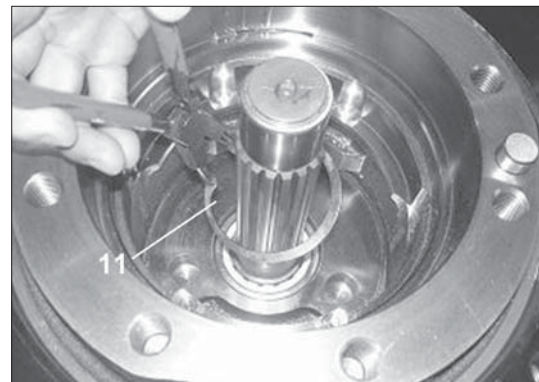

25098TM057

(13) Disassemble the shaft (8) from the casing (1).

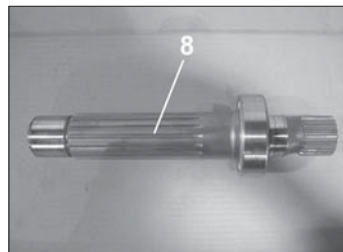

25098TM058

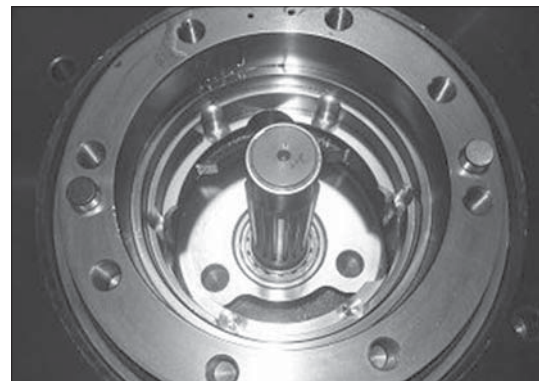

25098TM059

(14) Disassemble the snap ring (5) from the casing (1) with the pryer for retaining ring.

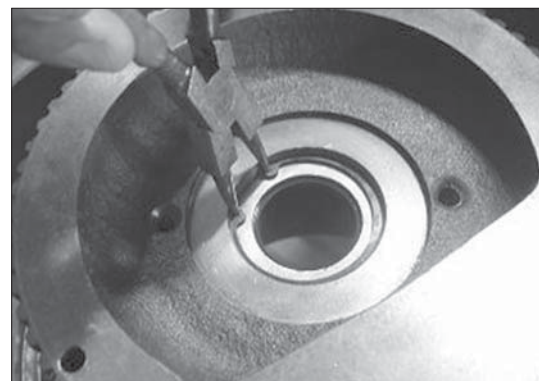

25098TM060

(15) Disassemble the thrust plate (4) from the casing (1).

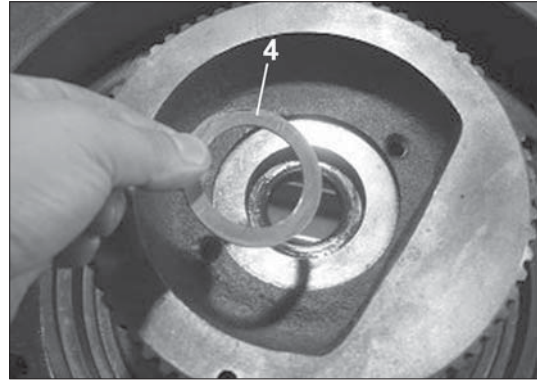

25098TM061

(16) Disassemble the oil seal (3) from the casing (1) with suitable tool.



25098TM062

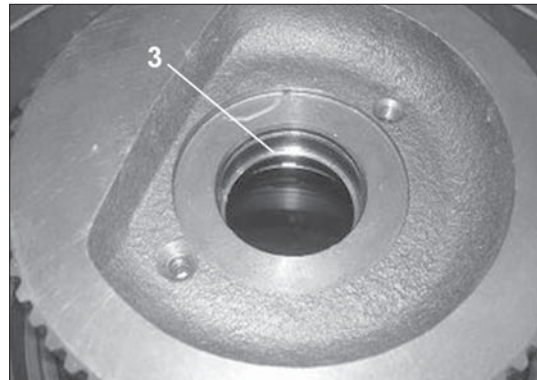

25098TM063

(17) Disassemble the O-ring (31) from the casing (1).

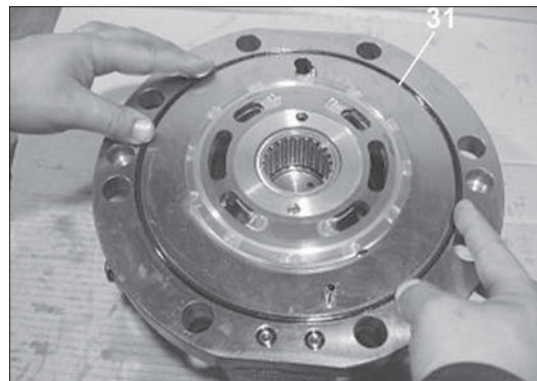

25098TM064

(18) Disassemble the valve plate (28) from the casing (1).

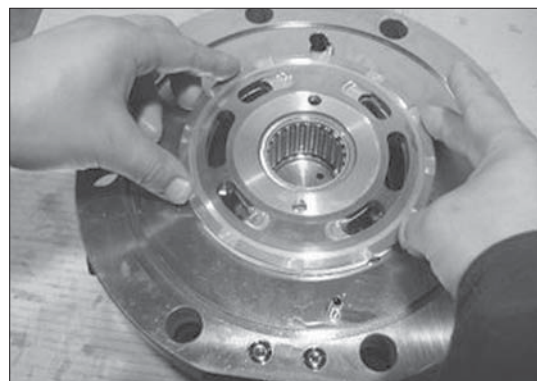

25098TM065

(19) Disassemble the relief valve (42, 2EA) from the rear cover (34) by using the torque wrench.

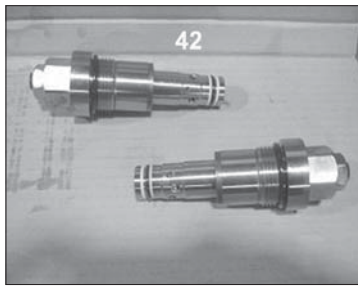

25098TM066

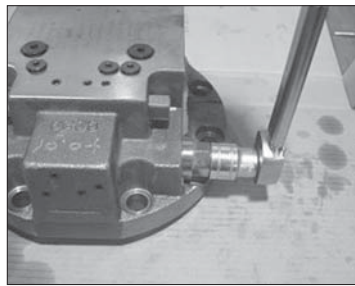

25098TM067

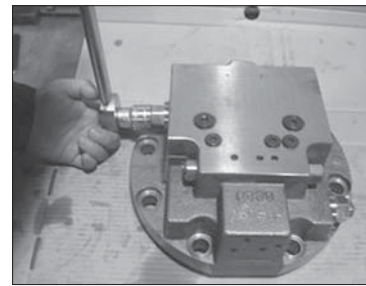

25098TM068

(20) Disassemble both side of the plug (48) and connector (52) from the rear cover (34) by using the torque wrench and then disassemble the spring (51), spring seat (49), parallel pin (50) and spool (47) in order.

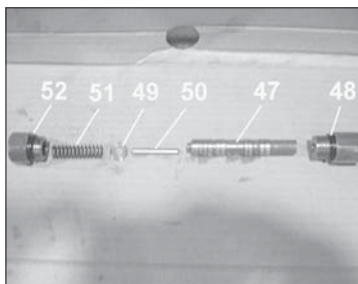

25098TM069

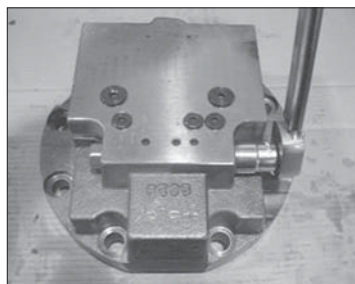

25098TM070

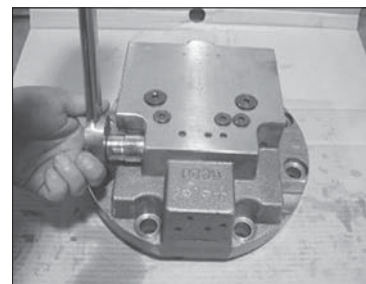

25098TM071

(21) Disassemble the plug (60) from the rear cover.

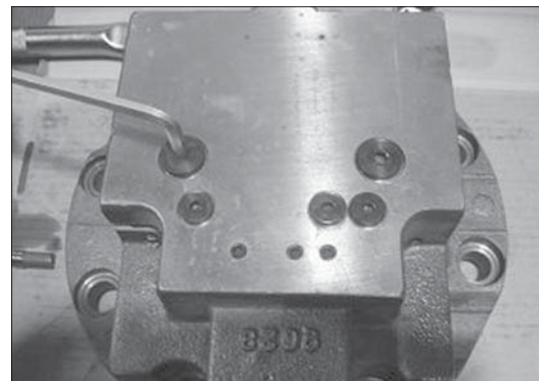

25098TM072

(22) Disassemble the plug (58) and then disassemble the spring (57) and check valve (56) from the rear cover in order.

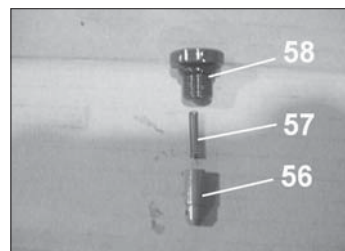

25098TM073

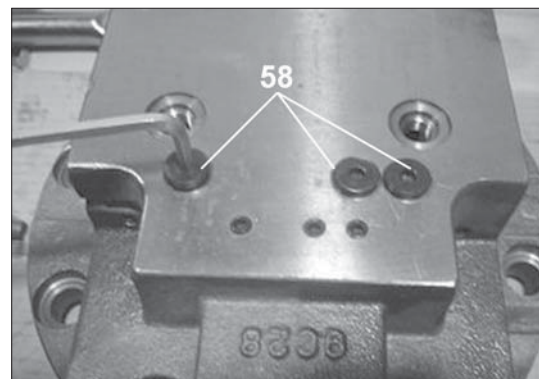

25098TM074

4. REASSEMBLING

1) ASSEMBLING MOTOR

- REAR COVER ASSY

- (1) Assemble the check valve (56) and the spring (57) to the rear cover and then tighten the plug (60) by using the L-wrench.

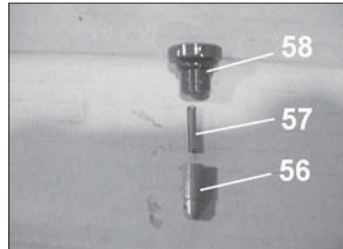

25098TM075

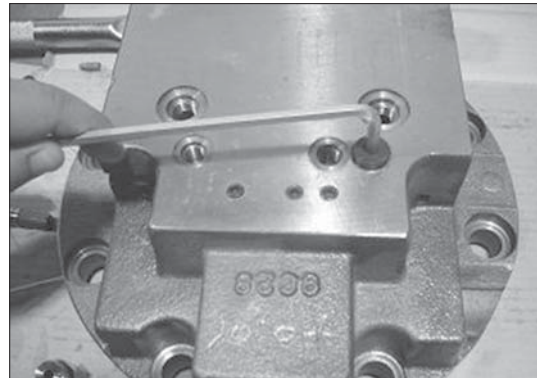

25098TM076

- (2) Apply the loctite #242 on the NPTF 1/16 plug (2, 12EA) and tighten it.

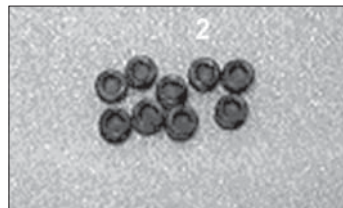

25098TM077



25098TM078

- (3) Assemble the spool (47), parallel pin (50), spring seat (49) and spring (51) into the rear cover (34) and tighten both side of the plug (48) and connector (52) into the rear cover (34).

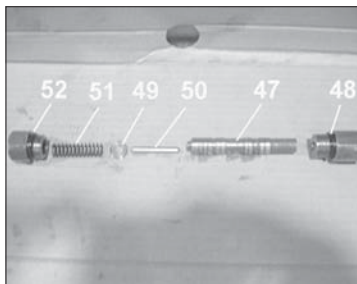

25098TM079

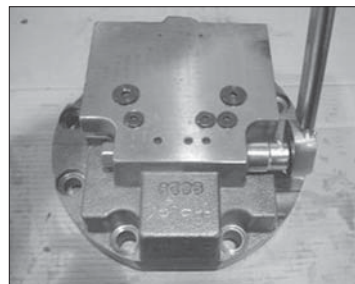

25098TM080

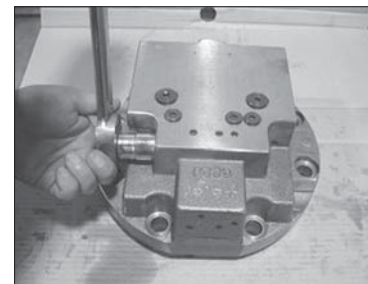

25098TM081

- (4) Assemble the relief valve (42, 2EA) into rear cover (34).

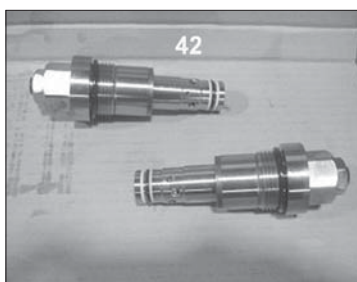

25098TM082

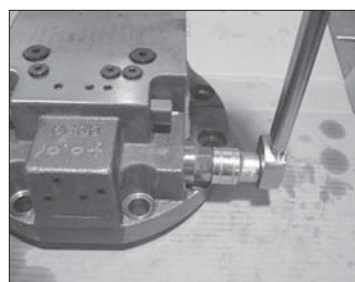

25098TM083

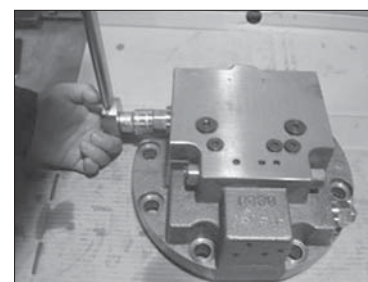

25098TM084

- (5) Tight fit the needle bearing (10) into rear cover (34) by using pressing jig.

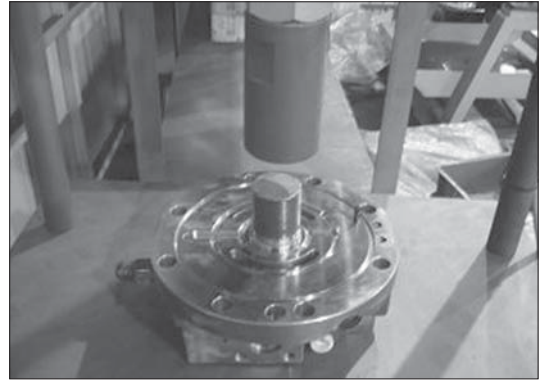

25098TM085

- (6) Assemble the spring pin (32) and parallel pin (29) into rear cover (34) by using round bar or small hammer.

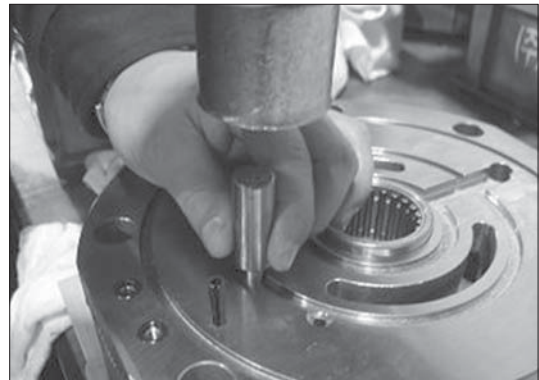

25098TM086

- (7) Assemble the valve plate (28) into rear cover (34).
Before assembling, apply some grease on contact surface of the valve plate.

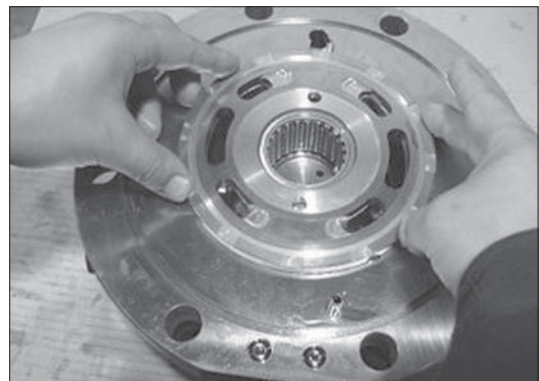

25098TM087

- (8) Apply some grease on the O-ring and fit it into groove.

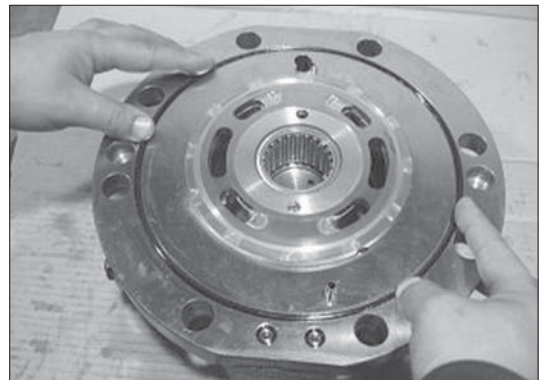

25098TM088

(9) Assemble the casing (1) on the assembling truck.

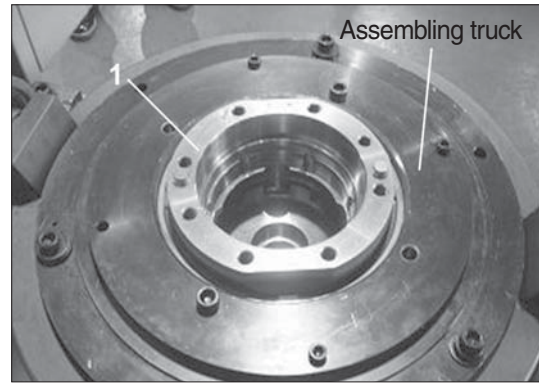

25098TM089

(10) Tight fit the oil seal (3) into the casing (1) by using jig.

※ Be careful direction of the oil seal.



25098TM090



25098TM091

(11) Assemble the thrust plate (4) into the casing (1).

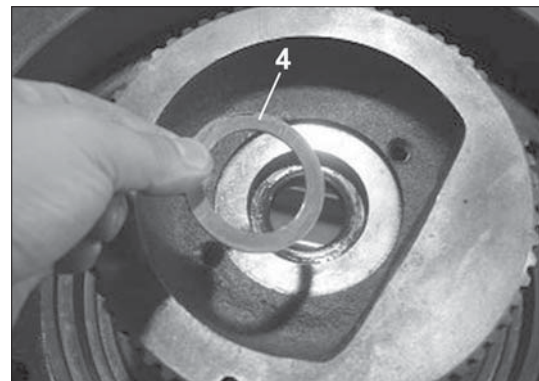

25098TM092

(12) Assemble the snap ring (5) into the casing (1) with the plier for retaining ring.

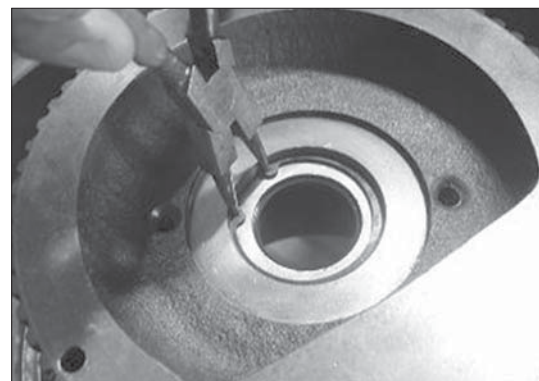

25098TM093

(13) Heat the roller bearing (9) and fit it into the shaft with shrink fitting.

- a. Shrink fitting can be used induction heating system and set the temperature at 100°C.
- b. Be careful not to damage the sliding surface of the oil seal of the shaft.



25098TM094



25098TM095

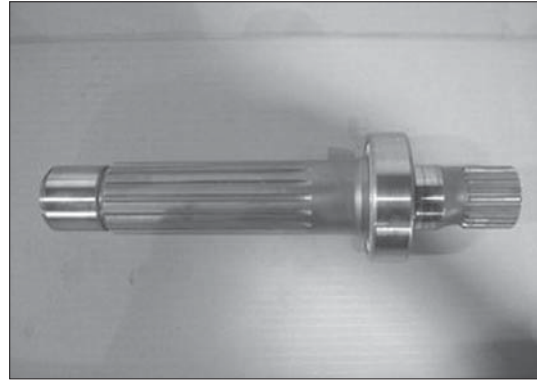

25098TM096

(14) Assemble the heat-fitted shaft (8) into casing (1).



25098TM097

(15) Assemble the snap ring (11) into the casing (1) with the plier for retaining ring.

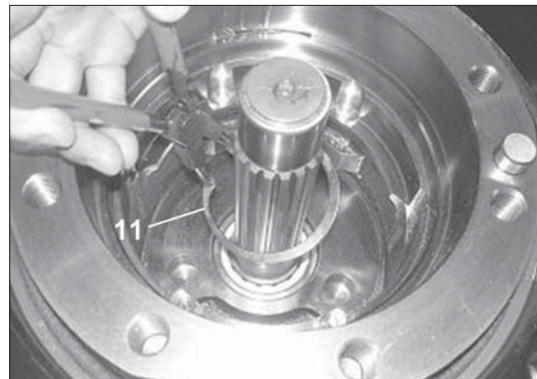

25098TM098

(16) Apply a little grease on the pivot (16, 2EA) and assemble it into the casing (1).

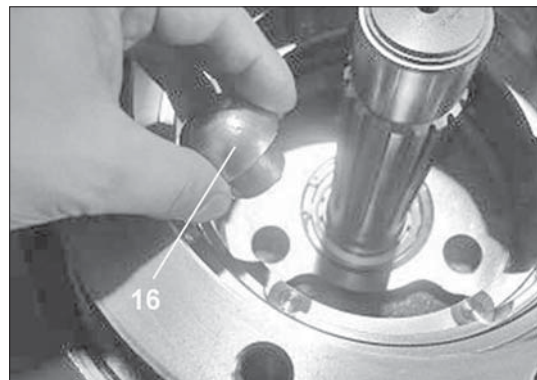

25098TM099

(17) Heat the piston seal (7) and fit it into the swash piston (6) and then tighten it a few minutes by band or tie. Loosen the band or tie and assemble it to the casing (1).



25098TM100

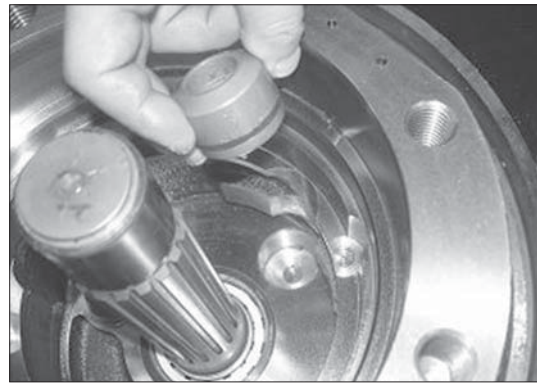

25098TM101

(18) Apply a little grease on the steel ball (15) and assemble it into the swash plate (17).

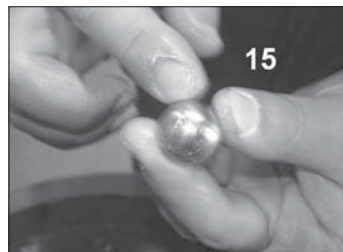

25098TM102



25098TM103

(19) Apply some grease on the steel ball hole of the swash plate (17) and assemble it casing (1).



25098TM104

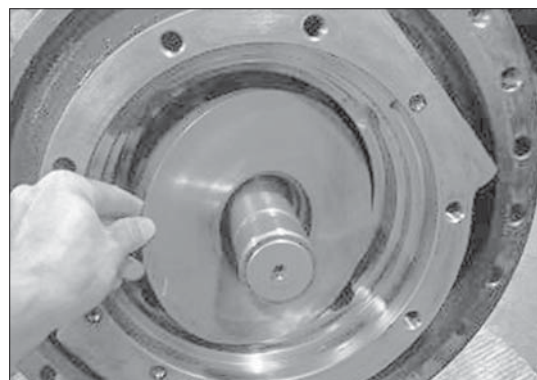

25098TM105

(20) Assemble the spring (19), ball guide (20), retainer plate (21) and piston assy (22) into cylinder block (18) in order.

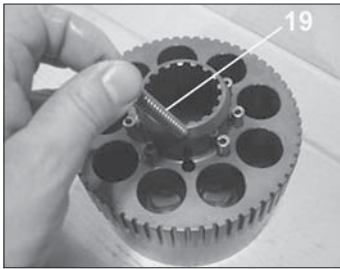

25098TM106

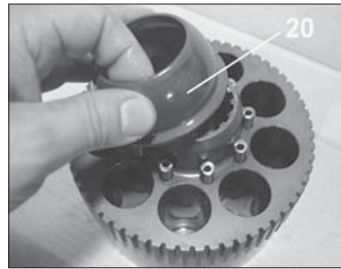

25098TM107

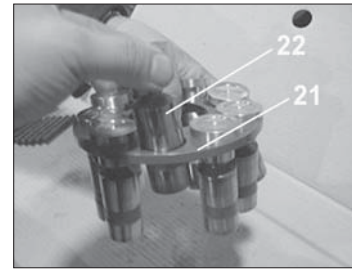

25098TM108

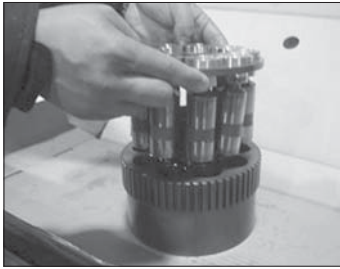

25098TM109



25098TM110

(21) Tilt the casing (1) sideways and assemble the cylinder block kit into the casing (1).

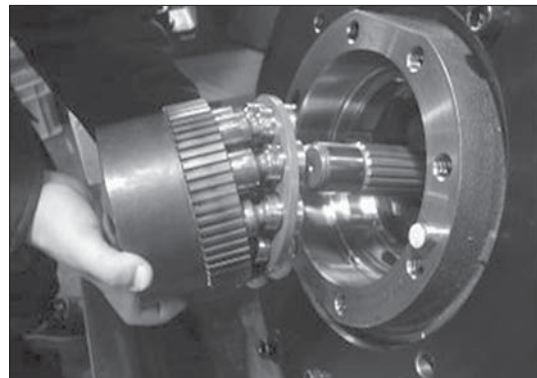

25098TM111

(22) Assemble the separated plate (24) and friction plate (23) into the cylinder block alternately.

Friction plate :

4EA

Separated plate :

5EA

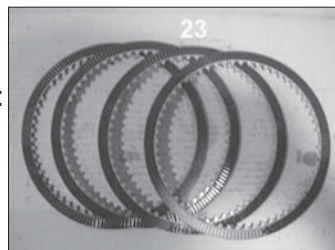

25098TM112

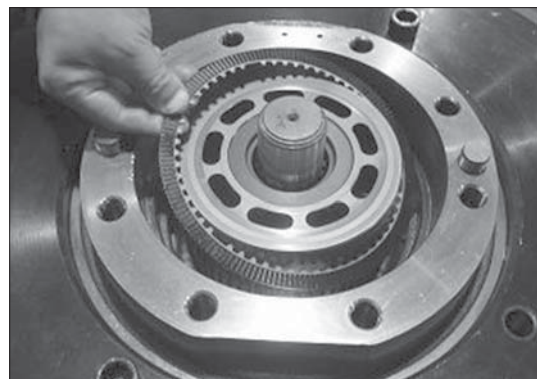

25098TM113

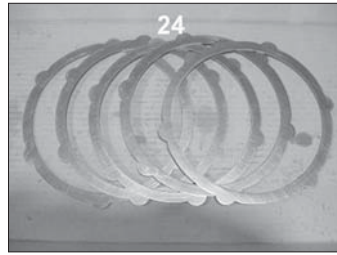

25098TM114

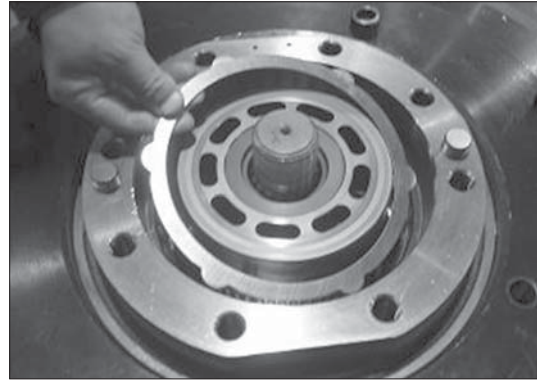

25098TM115

(23) Apply some grease on the D-ring and assemble it parking piston.

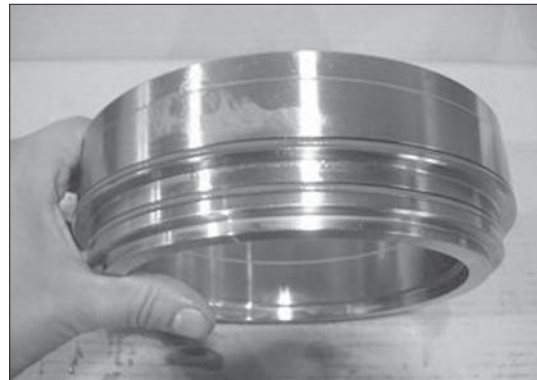

25098TM116

(24) Insert the parking piston into the casing and assemble it by using jig.

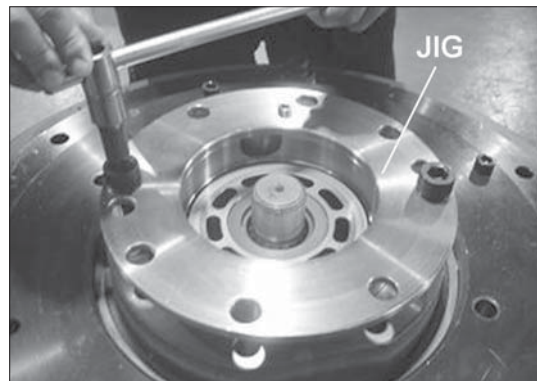

25098TM117

(25) Assemble the brake spring (30, 18EA) into the piston.

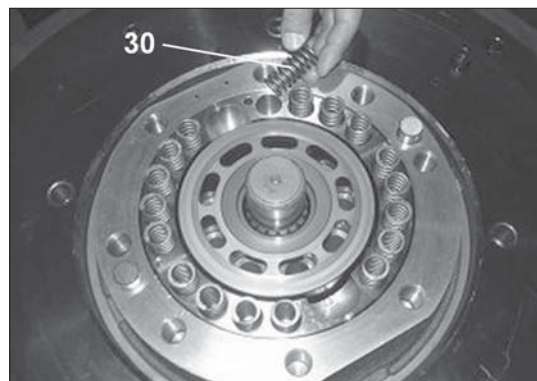

25098TM118

(26) Place the rear cover (34) on the casing (1).

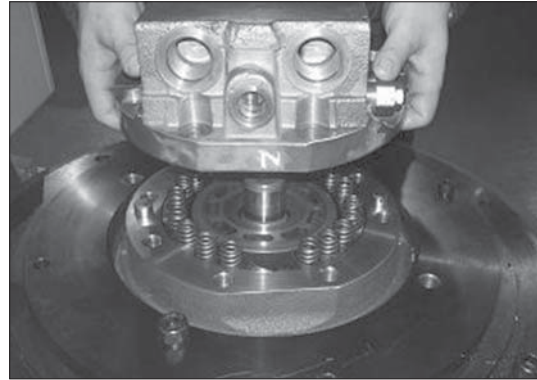

25098TM119

(27) Tighten the casing (1) and rear cover (34) specified torque with wrench bolt (54, 55) by using the impact wrench and torque wrench.

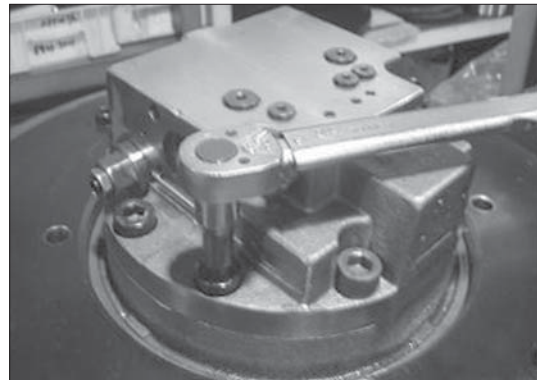

25098TM120

(28) Confirm the insert direction of the main spool assy (35) exactly and assemble it into the rear cover (34).

※ **Assure that four balance hole is directed VA port.**

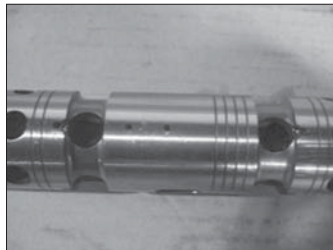

25098TM121

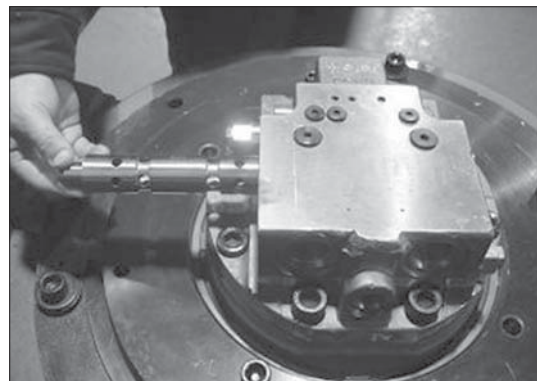

25098TM122

(29) Assemble the spring seat (41), spring (37) and main spool cover (36) into valve plate and tighten the wrench bolt (39, M12x35) by using L-wrench or impact wrench.

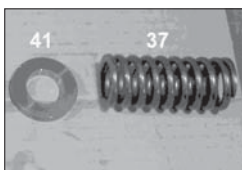

25098TM123

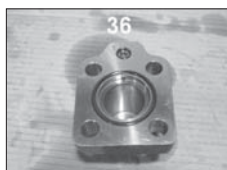

25098TM124

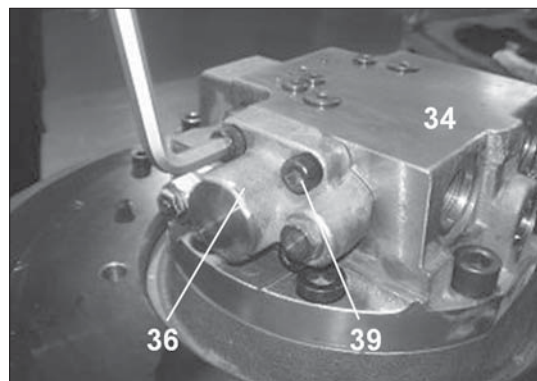

25098TM125

2) TRAVEL REDUCTION GEAR

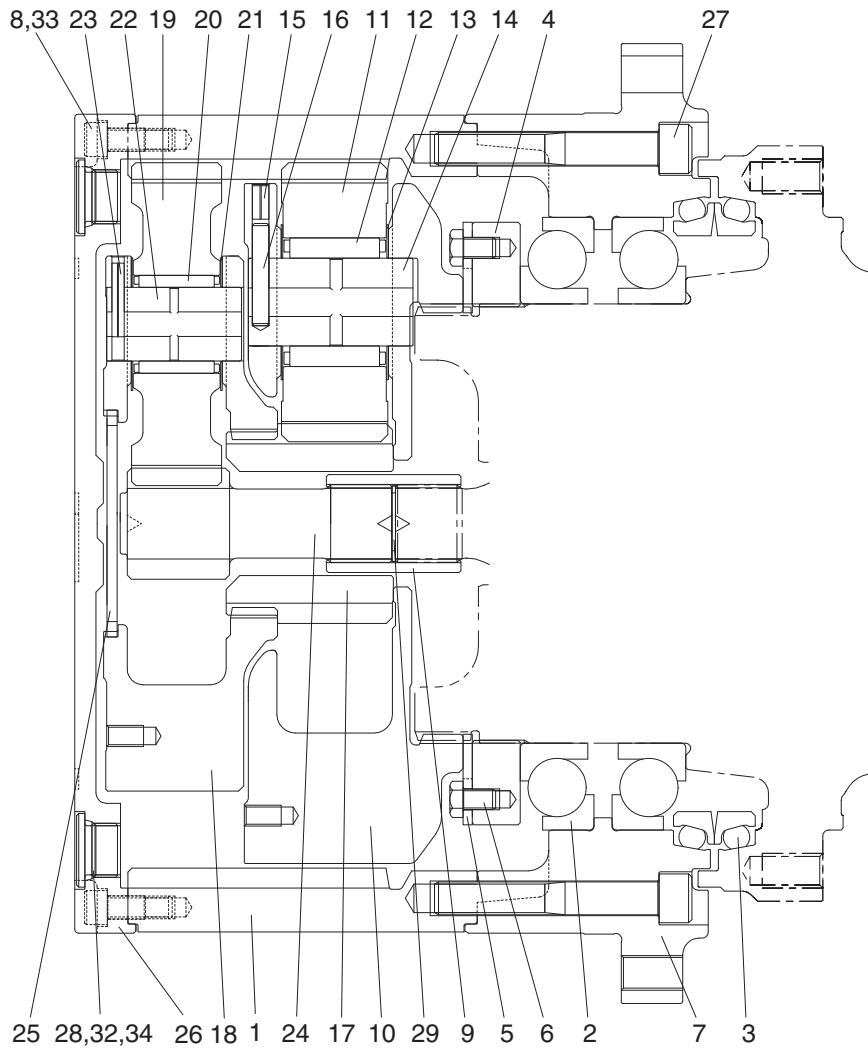

220S8TM02

1	Ring gear	13	Thrust washer 2	25	Thrust plate
2	Ball bearing	14	Carrier pin 2	26	Cover
3	Floating seal assy	15	Spring pin 2	27	Hexagon socket head bolt
4	Ring nut	16	Solid pin 2	28	Plug
5	Lock plate	17	Sun gear 2	29	Snap ring
6	Hexagon bolt	18	Carrier 1	30	Name plate
7	Housing	19	Planetary gear 1	31	Rivet
8	Hexagon socket head bolt	20	Needle bearing 1	32	O-ring
9	Coupling	21	Thrust washer 1	33	Rubber cap
10	Carrier 2	22	Carrier pin 1	34	Rubber cap
11	Planetary gear 2	23	Spring pin 1		
12	Needle bearing 2	24	Sun gear 1		

6. DISASSEMBLING

1) GENERAL INSTRUCTIONS

- ▲ Combustibles such as white kerosene are used for washing parts.**
These combustibles are easily ignited, and could result in fire or injury.
Be very careful when using.
 - ▲ Internal parts are coated with gear oil during disassembling and are slippery.**
If a part slips off from your hand and falls, it could result in bodily injury or could damage the park.
Be very careful when handling.
- (1) Therefore, disassembling and assembling works should be performed on the clean place where dusts hardly gather.
Tools and kerosene to wash parts should also be clean and handled with great care.
- (2) Before disassembling, review the sectional drawing and prepare the required parts, depending on the purpose and the range of disassembling.
Seals, O-rings, etc., if once disassembled, are not reusable.
There are some parts that should be replaced as a subassembly.
Consult with the parts manual in advance.
- ▲ Take great care not to pinch your hand between parts while disassembling nor let fall parts on your foot while lifting them.**

2) DISASSEMBLING TRAVEL REDUCTION GEAR

(1) Preparation for disassembling

- ① The reduction units removed from excavator are usually covered with mud. Wash outside of propelling unit and dry it.
- ② Locate reducer in order for drain port to be at the lowest level, loosen taper screw plug of drain port, and drain oil from reduction gear.

※ While oil is still hot, inside of the unit may be pressurized.

▲ Take care of the hot oil gushing out of the unit when loosening the plug.

③ Mark for mating

Put marks on each mating parts when disassembling so as to reassemble correctly as before.

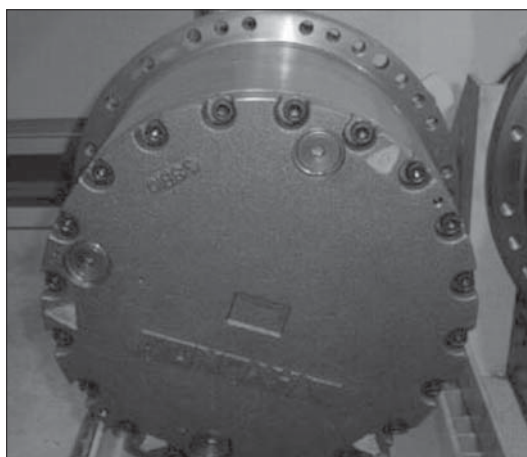

25098TM126

(2) Setting reduction unit (or whole propelling unit) on work stand for disassembling

- ① Remove 7/16-14UNC hexagon socket head bolts at 3 places from cover almost equally apart each other, and then install 7/16-14UNC eye bolts.

▲ Take great care not to pinch your hand between parts while disassembling nor let fall parts on your foot while lifting them.

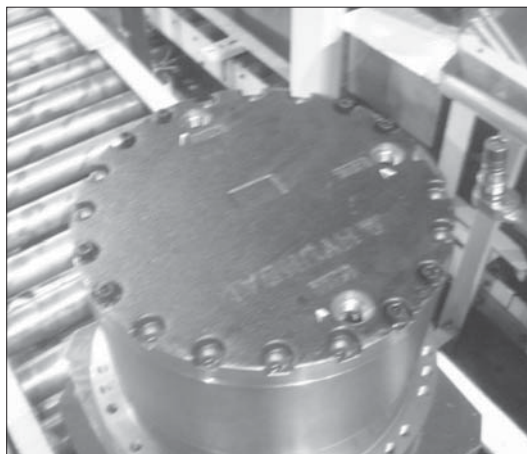

25098TM127

(3) Removing cover

- ① Remove the rest of 7/16-14UNC hexagon socket head bolts that secure cover and ring gear. Loosen all the socket bolts and then, disassemble cover.
- ② As the cover is adhered to ring gear, disassemble ring gear and cover by lightly hammering slantwise upward using sharpen punch inserted between the cover and ring gear.



25098TM128

(4) Removing No.1 carrier sub assembly

- ① Screw three M10 eye-bolt in No.1 carrier and lift up and remove No.1 carrier assy.

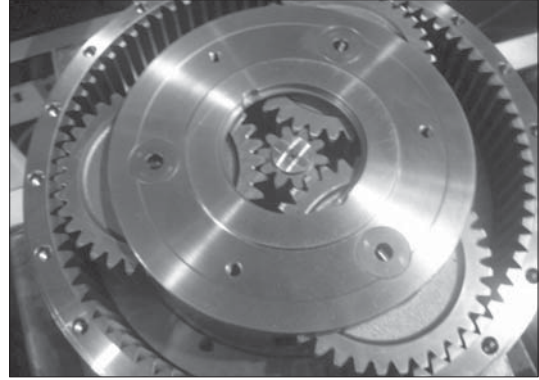

25098TM129

- ② Remove No.1 sun gear.

※ Be sure to maintain it vertical with the ground when disassembling No.1 sun gear.



25098TM130

(5) Removing No.2 carrier sub assembly

- ① Screw three M10 eye-bolt in No.2 carrier and lift up and remove No.2 carrier assy.

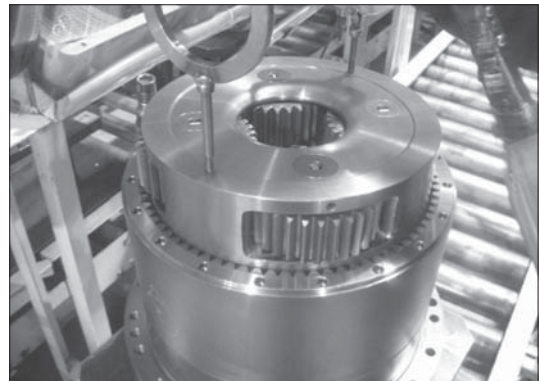

25098TM131

- ② Remove No.2 sun gear.

※ Be sure to maintain it vertical with the ground when disassembling No.1 sun gear.

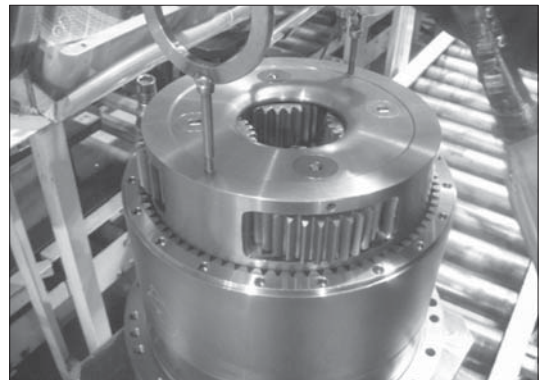

25098TM132

(6) Removing coupling

- ① Remove coupling.

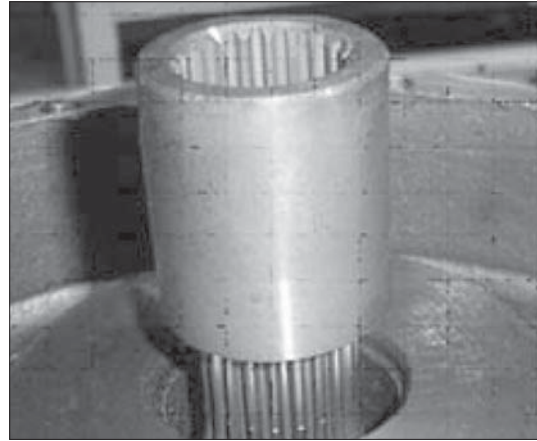

25098TM133

(7) Removing ring nut & lock plate

- ① Remove M12 hexagon head bolts that secure ring nut and lock plate.
- ② Remove lock plate.

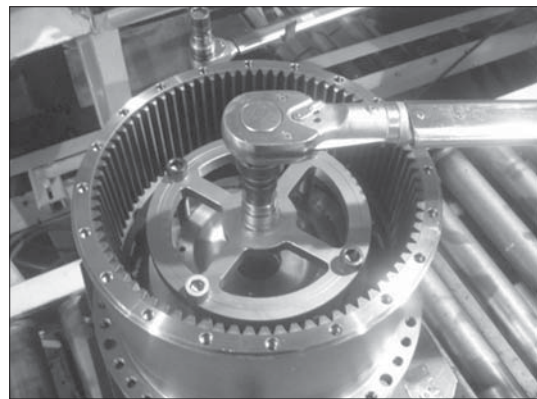

25098TM134

- ③ Remove ring nut from motor casing.
- ※ Remove the ring nut by using the special tool for removing the ring nut.

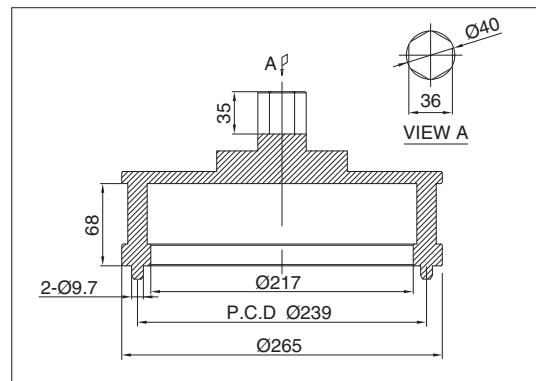

220L8TM01

(8) Removing housing sub assembly & ring gear

- ① Screw 7/16-14UNC eye bolt in housing and lift up ring gear and housing assembly including angular bearing and floating seal.

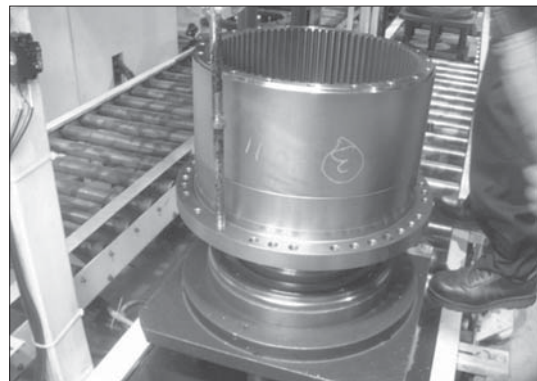

25098TM135

- ② Setting reduction unit on work stand for disassembling. Remove M16 hexagon socket head bolts that secure ring gear and housing assembly.

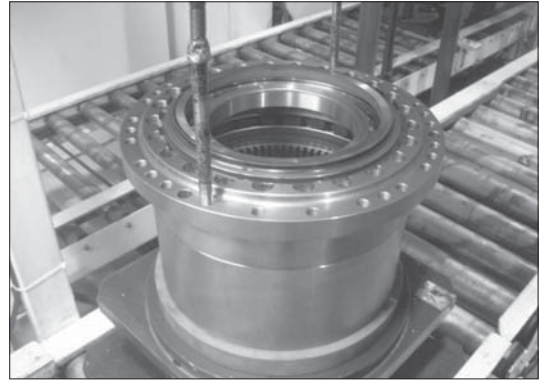

25098TM136

- ③ As the ring gear is adhered to housing assy, disassemble housing assy and ring gear by lightly hammering slantwise upward using sharpen punch inserted between the housing assy and ring gear.

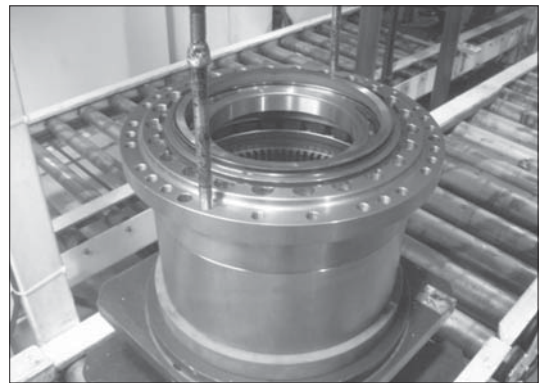

25098TM137

(9) Removing floating seal

- ① Lift up a piece of floating seal of motor side.

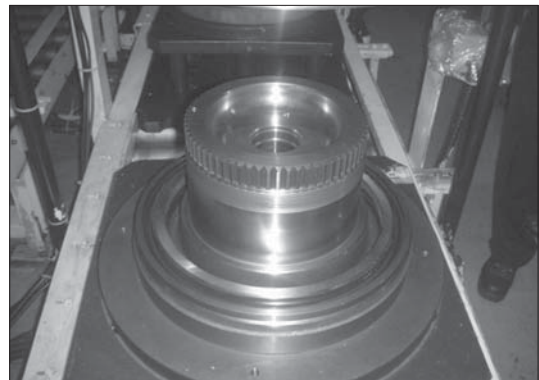

25098TM138

(10) Removing housing sub assembly

- ① Setting housing assembly on work stand for disassembling.
② After setting housing, lift up a piece of floating seal from housing and then remove it.
※ Don't disassemble angular bearing.

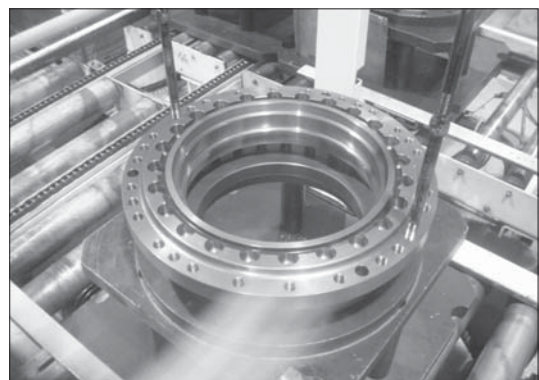

25098TM139

(11) Disassembling No.1 carrier

- ① Remove thrust plate.

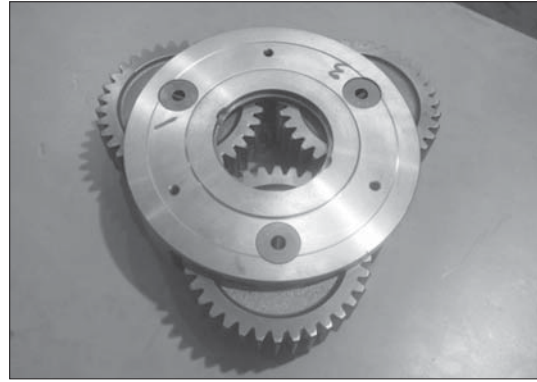

25098TM140

- ② Knock spring pin fully into No.1 pin.



25098TM141

- ③ Remove planetary, thrust washer, No.1 pin, bearing from carrier.

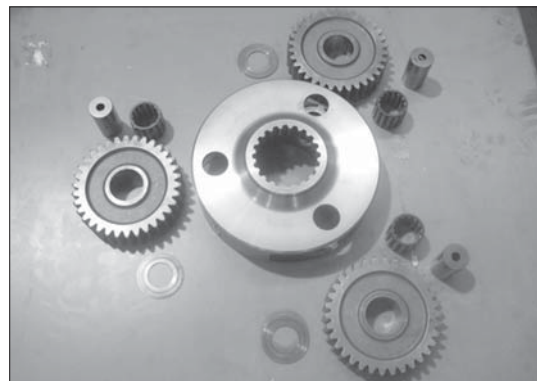

25098TM142

(12) Disassembling No.2 carrier

- ① Knock spring pin fully into No.2 pin.
- ② Remove No.2 solid pin.
- ③ Remove planetary, thrust washer, No.2 pin, bearing from carrier.



25098TM143

7. ASSEMBLY REDUTION UNIT

1) GENERAL NOTES

- (1) Clean every part by kerosene and dry them by air blow.
- (2) Surfaces to be applied by loctite must be decreased by solvent.
- (3) Check every part for any abnormal.
- (4) Each hexagon socket head bolt should be used with loctite No.242 applied on its threads.
- (5) Apply gear oil slightly on each part before assembling.

▲ Take great care not to pinch your hand between parts or tools while assembling nor let fall parts on your foot while lifting them.

Inspection before reassembling.

Thrust washer

- Check if there are seizure, abnormal wear or uneven wear.
- Check if wear is over the allowable limit.

Gear

- Check if there are pitting or seizure on the tooth surface.
- Check if there are cracks on the root of tooth by die check.

Bearing

- Rotate by hand to see if there are something unusual such as noise or uneven rotation.

Floating seal

- Check flaw or score on sliding surfaces or O-ring.

2) ASSEMBLING CARRIER 1 ASSY

- (1) Put No.1 carrier on a flat place.
- (2) Install No.1 needle bearing into No.1 planetary gear, put 2EA of No.1 thrust washer on both sides of planetary gear, and then, install it into carrier.



25098TM144

- (3) Install No.1 pin into No.1 carrier where the holes for No.1 pin are to be in line with those of No.1 carrier, and then, install spring pins into the holes.



25098TM145

(4) Caulk carrier holes as shown on the picture.



25098TM146

3) ASSEMBLING CARRIER 2 ASSY

- (1) Put No.2 carrier on a flat place.
- (2) Install No.2 needle bearing into No.2 planetary gear, put 2EA of No.2 thrust washer on both sides of planetary gear, and then, install it into carrier.

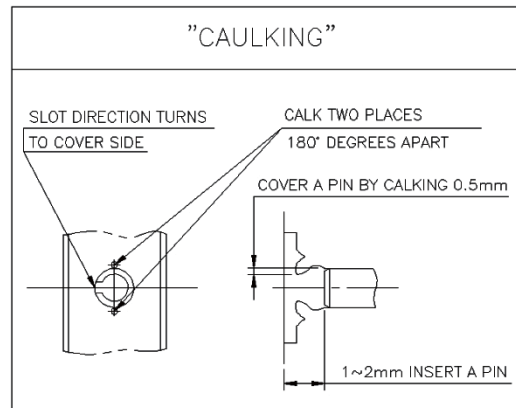

25098TM147

- (3) After install solid pin into the holes, install No.2 pin into No.1 carrier where the holes for No.1 pin are to be in line with those of No.1 carrier, and then, install spring pins into the holes.
- (4) Caulk carrier holes as shown on the picture.



25098TM148

4) ASSEMBLING FLOATING SEAL

- (1) Assemble floating seal into motor by use of pressing jig.
Grease the contact parts for floating seal which is assembled into motor.
- ※ Be sure to maintain it vertical with the ground when assembling bearing and floating seal.

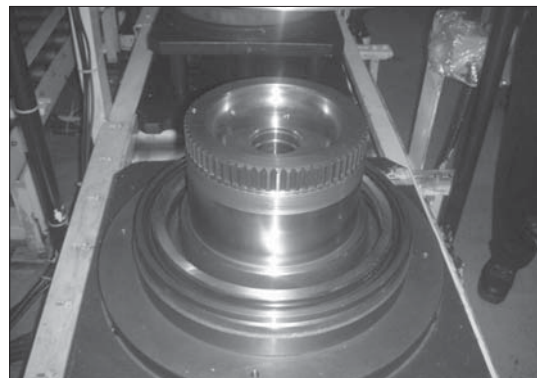

25098TM149

5) ASSEMBLING HOUSING

- (1) Heat housing at 60~70°C while clearing it out and then, assemble floating seal into housing by use of pressing jig.
- (2) Setting housing assembly on work stand for assembling.
Assemble angular bearing into housing by use of pressing jig.

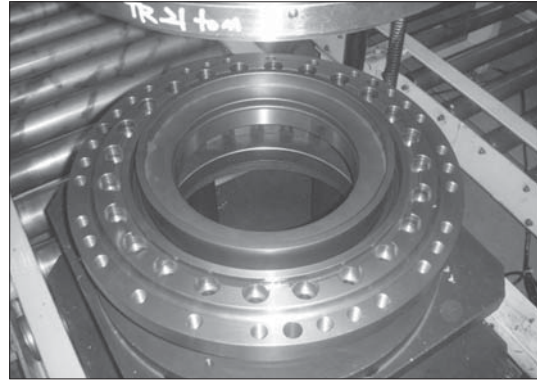

25098TM150

- (3) Assemble floating seal into housing by use of pressing jig.
Do not reuse the disassembling O-ring.
Grease the contact parts for floating seal which is assembled into housing.
- ※ Be sure to maintain it vertical with the ground when assembling bearing and floating seal.



25098TM151

6) ASSEMBLING HOUSING ASSY AND RING GEAR

- (1) Setting ring gear on work stand for assembling.
Apply loctite #515 on ring gear for housing without gap.

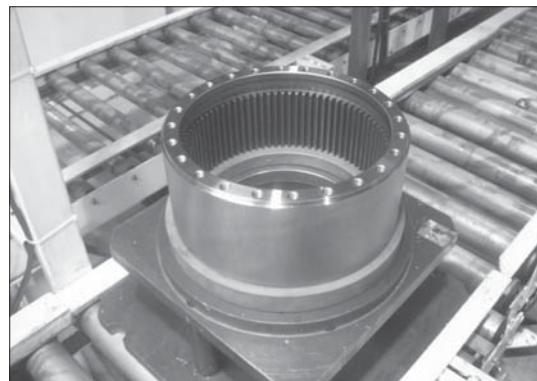

25098TM152

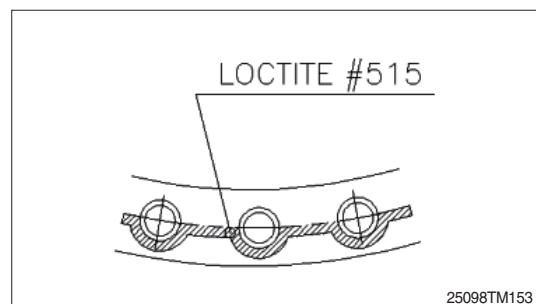

25098TM153

- (2) Install M16 eye-bolt on the tap of housing.
- (3) Lift housing and then, assemble into housing in order for bolt hole of ring gear and bolt hole of housing to be in line.
- (4) Apply loctite #242 on M16 hexagon socket head bolt, and then, bolt.

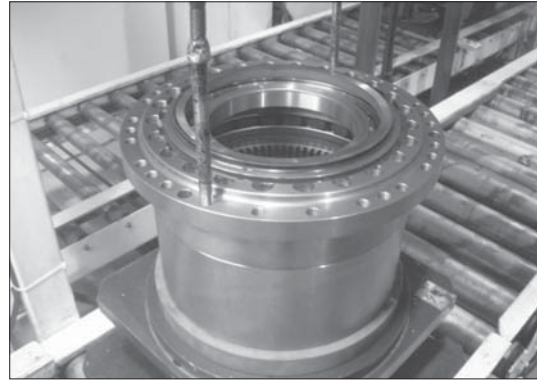

25098TM154

7) ASSEMBLING HOUSING ASSY AND MOTOR

- (1) Install 7/16-14UNC eye-bolt on the tap of ring gear.
 - (2) Assemble housing assembly into motor by use of hoist and eye-bolt.
- ※ Be sure to tighten eye-bolt deep enough.

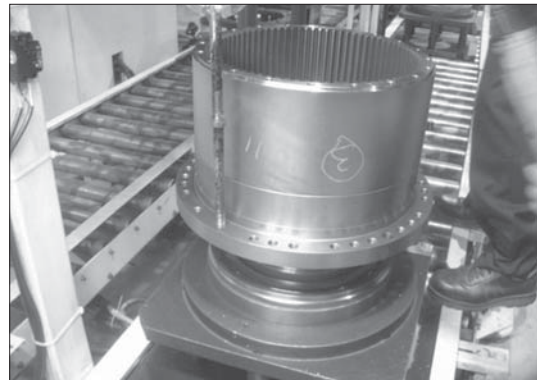

25098TM155

8) ASSEMBLING MAIN BEARING

- (1) Assemble angular bearing into housing by use of pressing jig.
- ※ Be sure to maintain it vertical with the ground when assembling bearing.



25098TM156

9) ASSEMBLING NUT RING AND LOCK PLATE

- (1) Tighten nut ring to specified torque, utilizing special tool.
 - Tightening torque : 60.3 kgf·m
(436 lbf·ft)
- (2) After install lock plate, apply loctite #242 on M12 hexagon head bolt, and then, bolt. Tighten M12 hexagon head bolt to specified torque, with torque wrench.

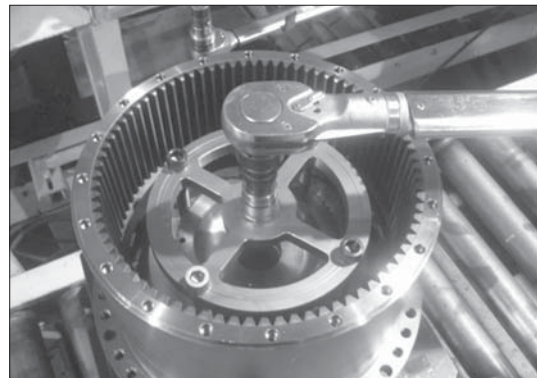

25098TM157

10) ASSEMBLING COUPLING

- (1) Install coupling on spline of the motor.

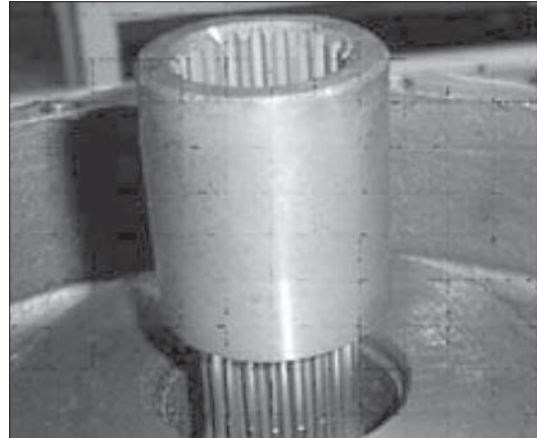

25098TM158

11) ASSEMBLING NO.2 CARRIER SUB ASSEMBLY

- (1) Install M10 eye-bolt on No.2 carrier assembly.
 - (2) Lift No.2 carrier assembly and then, slowly put it down on ring gear.
 - (3) Rotate planetary gear by hands and install on ring gear.
 - (4) Rotate No.2 carrier assembly by hands and install on motor.
- ※ Match pin hole of No.2 carrier with main (A, B) port of motor.

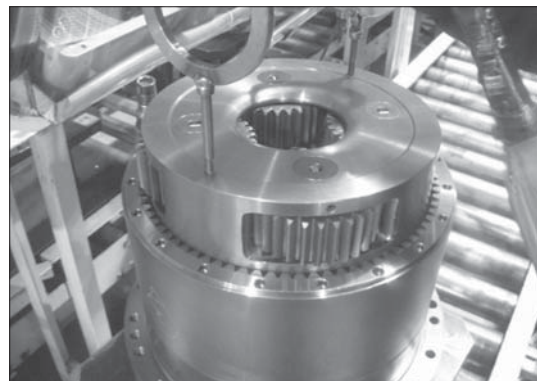

25098TM159

12) ASSEMBLING NO.2 SUN GEAR

- (1) Install No.2 sun gear on the No.2 planetary gear, matching teeth of them.

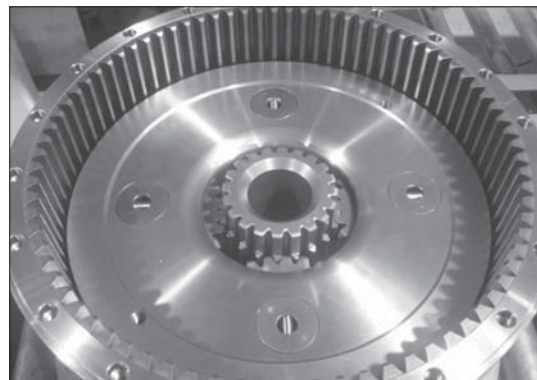

25098TM160

13) ASSEMBLING NO.1 CARRIER SUB ASSEMBLY

- (1) Install M10 eye-bolt on No.1 carrier assembly.
- (2) Lift No.1 carrier assembly and then, slowly put it down on ring gear.
- (3) Rotate planetary gear by hands and install on ring gear.
- (4) Rotate No.1 carrier assembly by hands and install on No.2 sun gear.

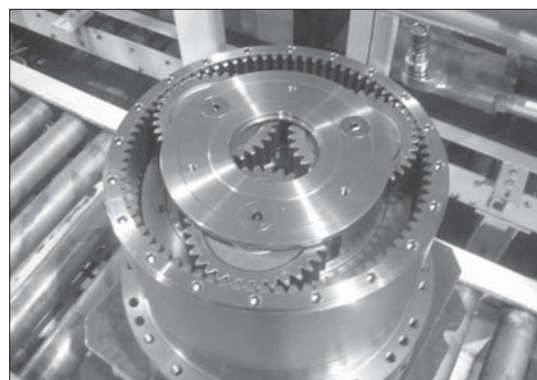

25098TM161

14) ASSEMBLING NO.1 SUN GEAR

- (1) Put down No.1 sun gear on No.1 carrier, maintaining it vertical with spline of coupling.
- (2) Install No.1 sun gear on No.1 planetary gear, matching their teeth.

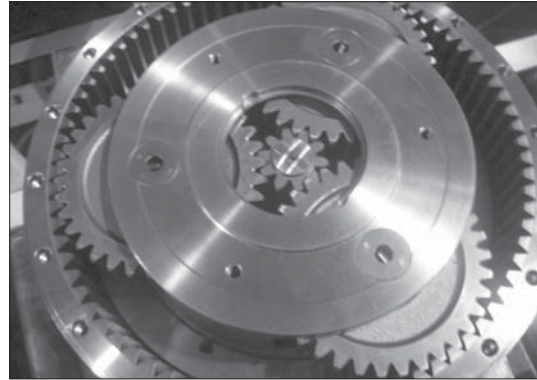

25098TM162

15) ASSEMBLING THRUST PLATE

- (1) Assembly thrust plate into No.1 carrier.
- ※ Edge of thrust plate direction turns to cover side.

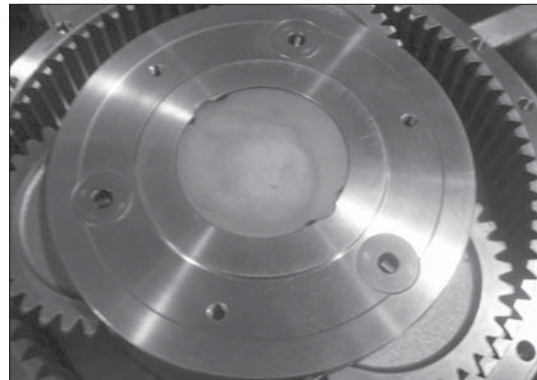

25098TM163

16) ASSEMBLING COVER

- (1) Apply loctite #515 on the ring gear for cover without gap.

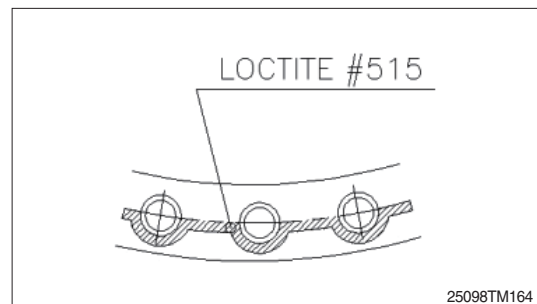

25098TM164

- (2) Put cover on ring gear, apply loctite #242 on 7/16-14UNC hexagon socket head bolt, and then, bolt.
Tighten 7/16-14UNC hexagon socket head bolt to specified torque, with torque wrench.
- (3) Fill gear oil (6 liter) into drain port.
- (4) Apply gear oil on PF3/4 hydraulic plug and then, bolt.

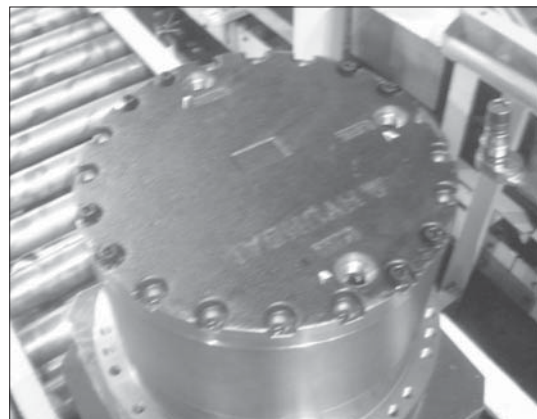

25098TM165

GROUP 7 RCV LEVER

1. REMOVAL AND INSTALL

1) REMOVAL

- (1) Lower the work equipment to the ground and stop the engine.
- (2) Operate the control levers and pedals several times to release the remaining pressure in the hydraulic piping.
- (3) Loosen the breather slowly to release the pressure inside the hydraulic tank.

▲ Escaping fluid under pressure can penetrate the skin causing serious injury.

- (4) Loosen the socket bolt (1).
Tightening torque : $1.05 \pm 0.2 \text{ kgf} \cdot \text{m}$
($7.6 \pm 1.45 \text{ lbf} \cdot \text{ft}$)
- (5) Remove the cover of the console box.
- (6) Disconnect pilot line hoses (3).
- (7) Remove the pilot valve assembly (2).
※ When removing the pilot valve assembly, check that all the hoses have been disconnected.

2) INSTALL

- (1) Carry out installation in the reverse order to removal.
- (2) Confirm the hydraulic oil level and check the hydraulic oil leak or not.

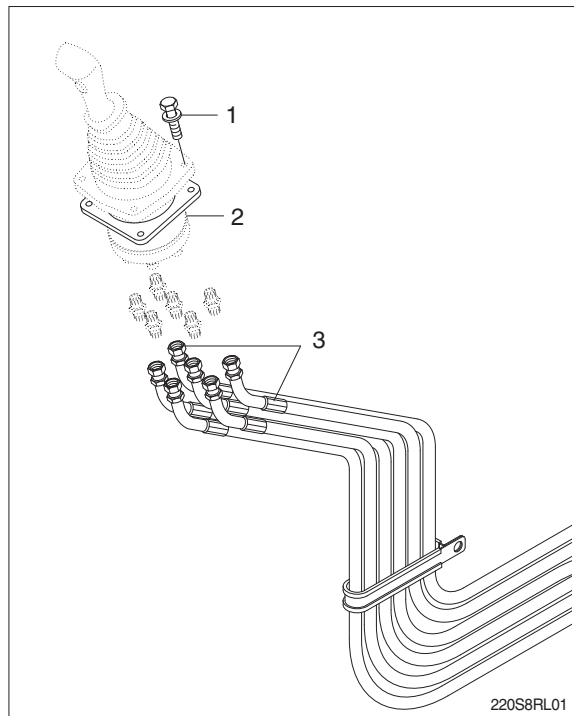

2. DISASSEMBLY AND ASSEMBLY

1) STRUCTURE

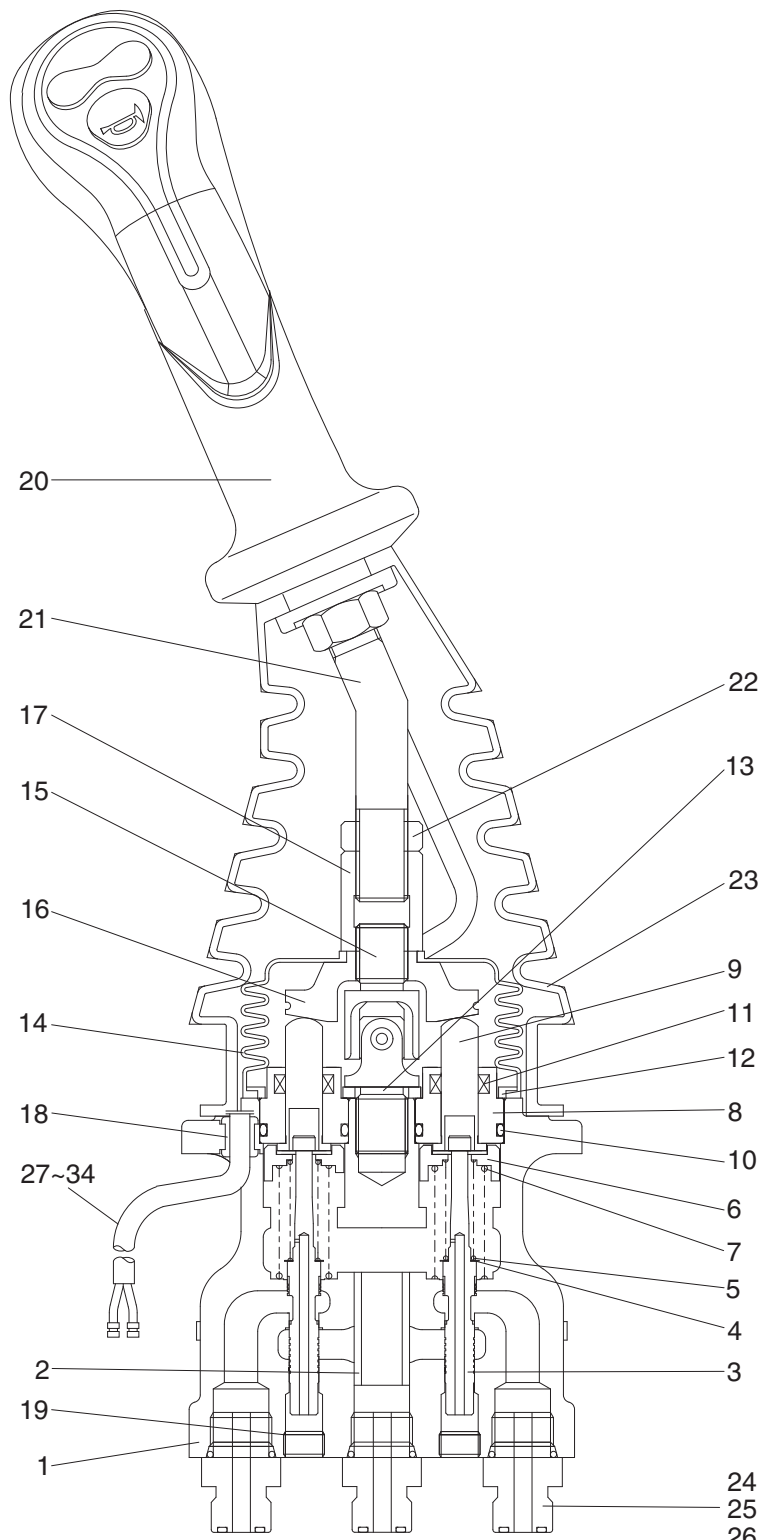

- 1 Case
- 2 Bushing
- 3 Spool
- 4 Shim
- 5 Spring
- 6 Spring seat
- 7 Spring
- 8 Plug
- 9 Push rod
- 10 O-ring
- 11 Rod seal
- 12 Plate
- 13 Spacer
- 14 Boot
- 15 Joint assembly
- 16 Swash plate
- 17 Adjusting nut
- 18 Bushing
- 19 Plug
- 20 Handle assembly
- 21 Handle bar
- 22 Nut
- 23 Boot
- 24 Last guard filter
- 25 Connector
- 26 Connector
- 27 Connector
- 28 Connector
- 27 Connector
- 29 Connector
- 30 Connector
- 31 Small guide
- 32 Connector
- 33 Big guide
- 34 Connector

210S2RL06

2) TOOLS AND TIGHTENING TORQUE

(1) Tools

Tool name	Remark	
Allen wrench	6	
Spanne	22	
	27	
(+) Driver	Length 150	
(-) Driver	Width 4~5	
Torque wrench	Capable of tightening with the specified torques	

(2) Tightening torque

Part name	Item	Size	Torque	
			kgf · m	lbf · ft
Joint	15	M14	3.5	25.3
Swash plate	16	M14	5.0±0.35	36.2±2.5
Adjusting nut	17	M14	5.0±0.35	36.2±2.5
Lock nut	22	M14	5.0±0.35	36.2±2.5

3) DISASSEMBLY

※ Procedures are based on the type M1.

- (1) Clean pilot valve with kerosene.
 - ※ Put blind plugs into all ports
- (2) Fix pilot valve in a vise with copper (or lead) sheets.
- (3) Remove end of boot (23) from case (1) and take it out upwards.

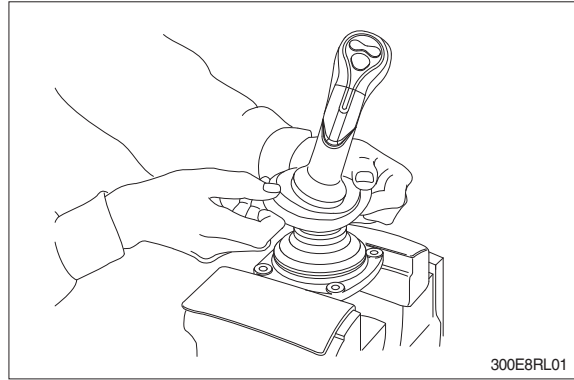

※ For valve with switch, remove cord also through hole of casing.

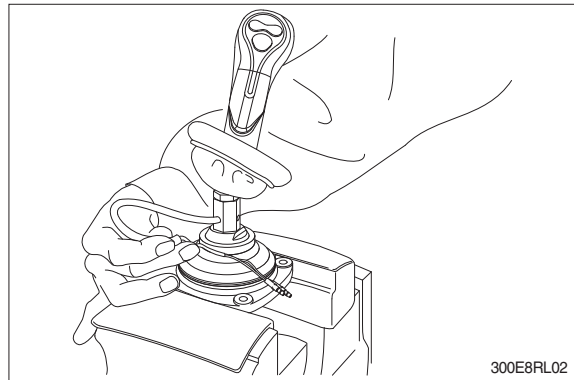

- (4) Loosen lock nut (22) and adjusting nut (17) with spanners on them respectively, and take out handle section as one body.

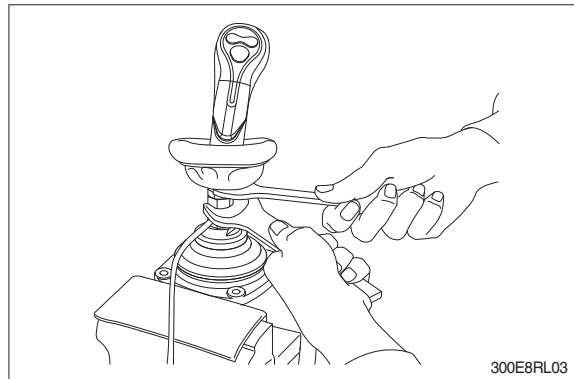

- (5) Remove the boot (14).

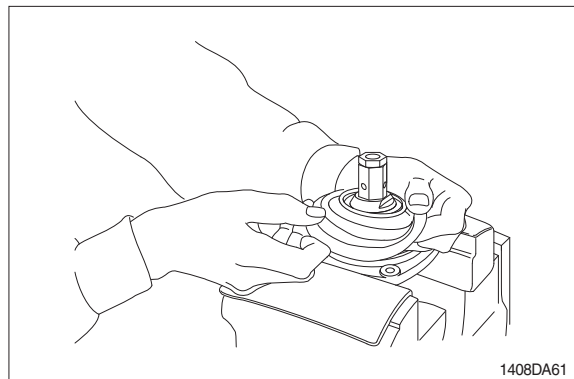

- (6) Loosen adjusting nut (17) and swash plate (16) with spanners on them respectively, and remove them.

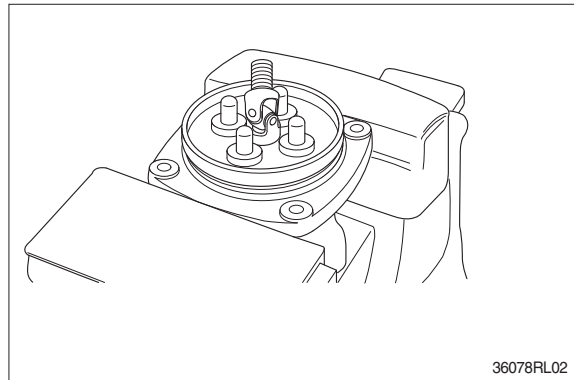
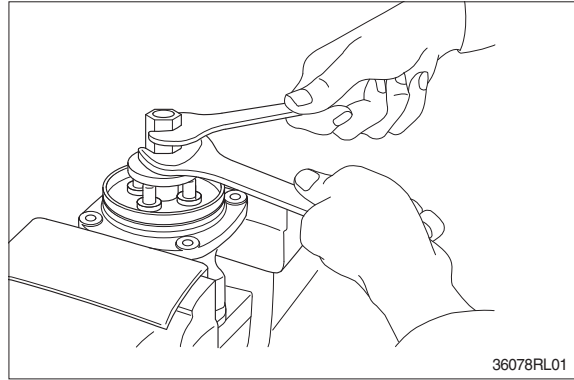

- (7) Turn joint anticlockwise to loosen it, utilizing jig (Special tool).

- ※ When return spring (7) is strong in force, plate (12), plug (8) and push rod (9) will come up on loosening joint. Pay attention to this.

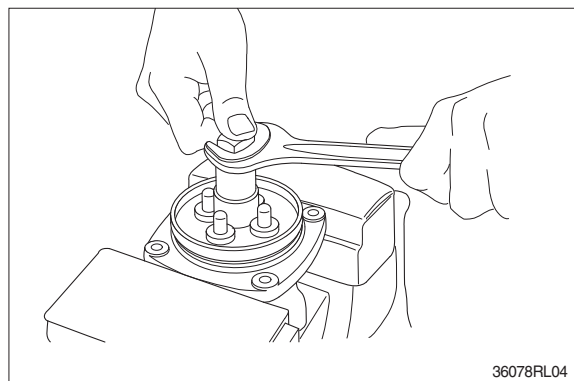
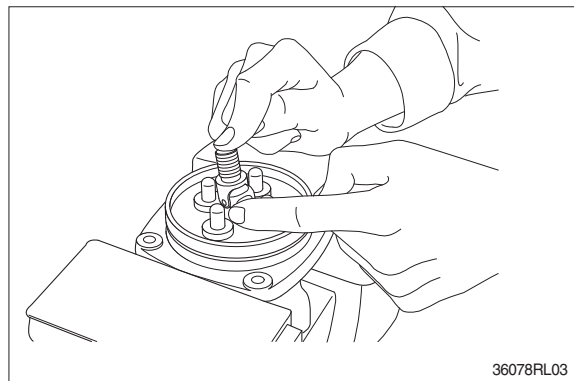

(8) Remove plate (12).

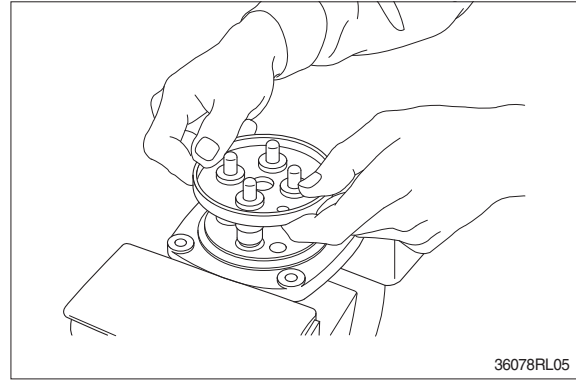

(9) When return spring (7) is weak in force, plug (8) stays in casing because of sliding resistance of O-ring.

- ※ Take it out with minus screwdriver. Take it out, utilizing external periphery groove of plug and paying attention not to damage it by partial loading.
- ※ During taking out, plug may jump up due to return spring (7) force. Pay attention to this.

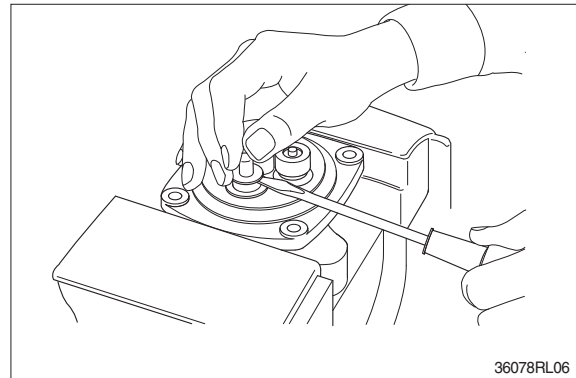

(10) Remove reducing valve subassembly and return spring (7) out of casing.

- ※ Record relative position of reducing valve subassembly and return springs.

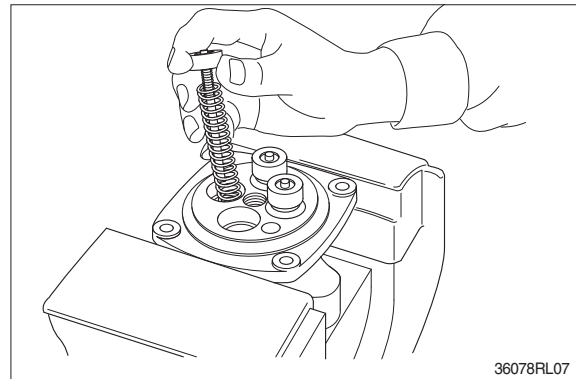

(11) Separate spool (3), spring seat (6), spring (5) and shim (4) individually.

- ※ Pay attention not to damage spool surface.
- ※ Record original position of spring seat (6).
- ※ Until being assembled, they should be handled as one subassembly group.

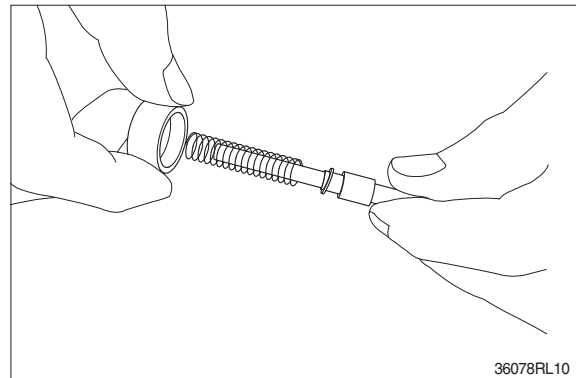

(12) Take push rod (9) out of plug (8).

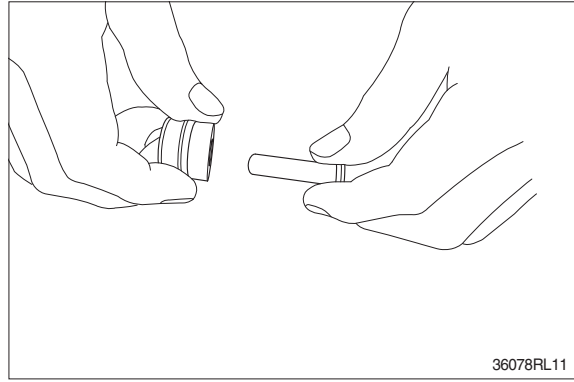

(13) Remove O-ring (10) and seal (11) from plug (8).
Use small minus screwdriver or so on to remove this seal.

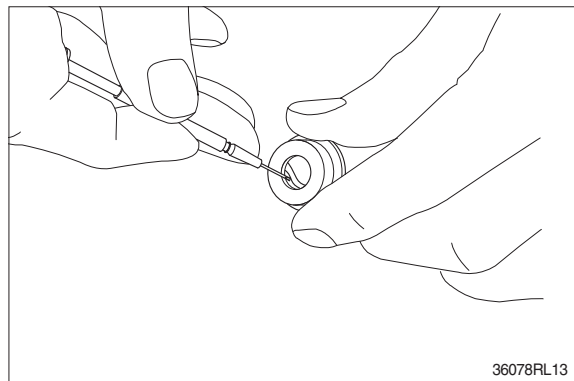
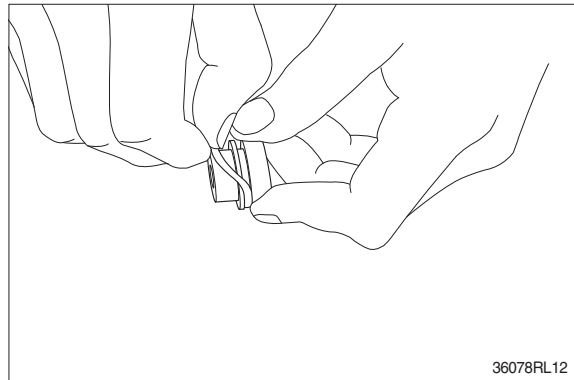

(14) Remove lock nut (22) and then boot (23).

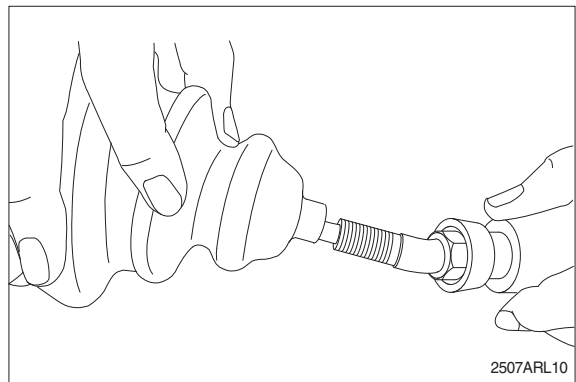
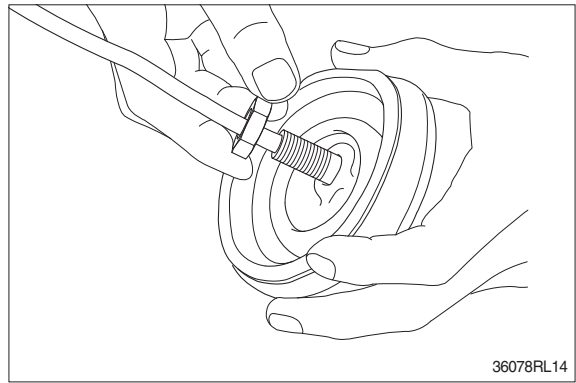

(15) Cleaning of parts

- ① Put all parts in rough cleaning vessel filled with kerosene and clean them (rough cleaning).
 - ※ If dirty part is cleaned with kerosene just after putting it in vessel, it may be damaged. Leave it in kerosene for a while to loosen dust and dirty oil.
 - ※ If this kerosene is polluted, parts will be damaged and functions of reassembled valve will be degraded.
Therefore, control cleanliness of kerosene fully.
- ② Put parts in final cleaning vessel filled with kerosene, turning it slowly to clean them even to their insides (finish cleaning).
 - ※ Do not dry parts with compressed air, since they will be damaged and/or rusted by dust and moisture in air.

(16) Rust prevention of parts

- Apply rust-preventives to all parts.
- ※ If left as they are after being cleaned, they will be rusted and will not display their functions fully after being reassembled.

4) ASSEMBLY

- (1) Put shim (4), springs (5) and spring seat (6) onto spool (3) in this order.

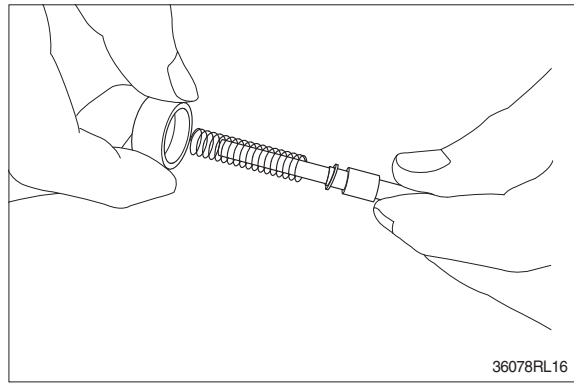

- (2) Assemble spring (7) into casing (1).
Assemble reducing valve subassembly into casing.
※ Assemble them to their original positions.

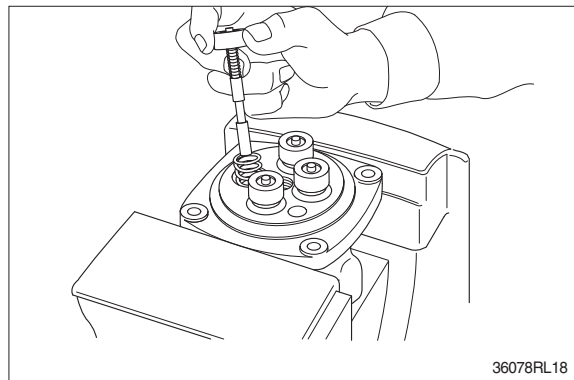

- (3) Assemble O-ring (10) onto plug (8).

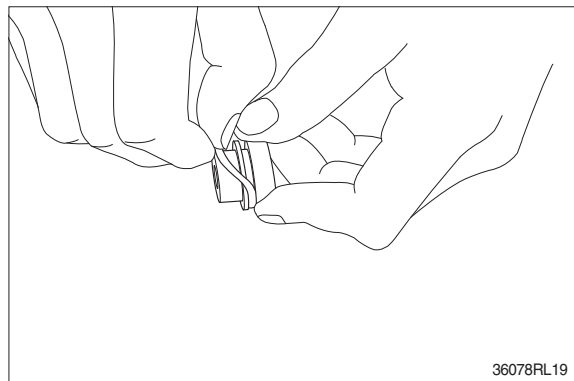

- (4) Assemble seal (11) to plug (8).
※ Assemble seal in such lip direction as shown below.

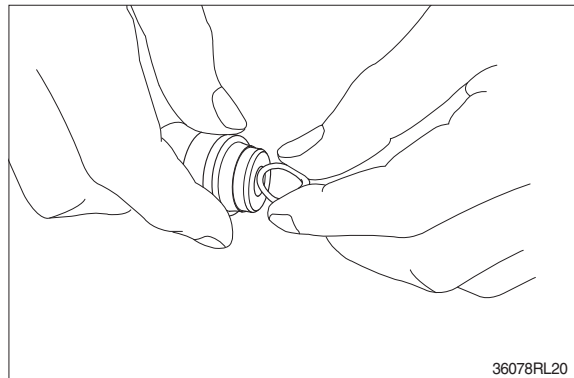

- (5) Assemble push rod (9) to plug (8).
※ Apply working oil on push-rod surface.

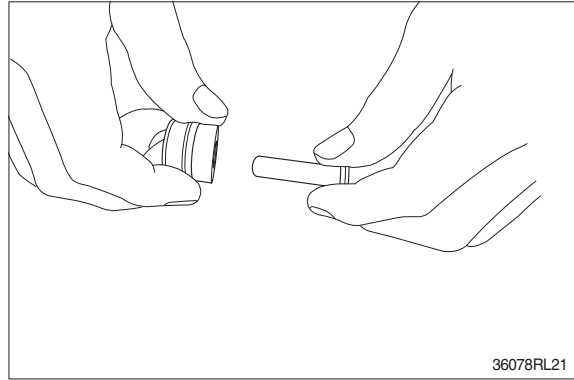

- (6) Assemble plug subassembly to casing.
※ When return spring is weak in force, subassembly stops due to resistance of O-ring.

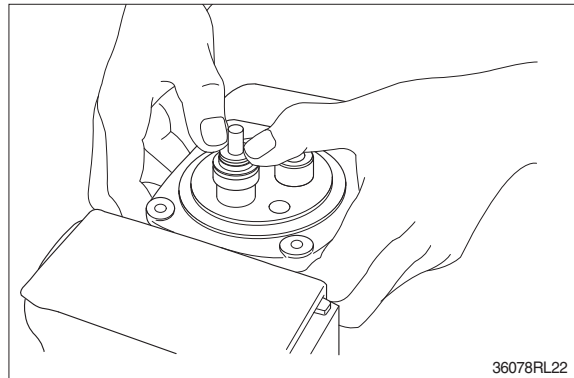

- (7) When return spring is strong in force, assemble 4 sets at the same time, utilizing plate (12), and tighten joint (15) temporarily.

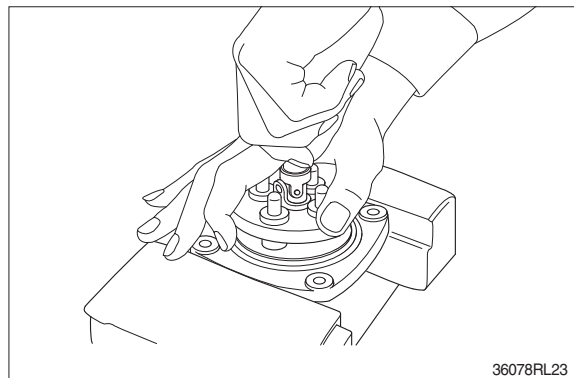

- (8) Fit plate (12).

- (9) Tighten joint (15) with the specified torque to casing, utilizing jig.

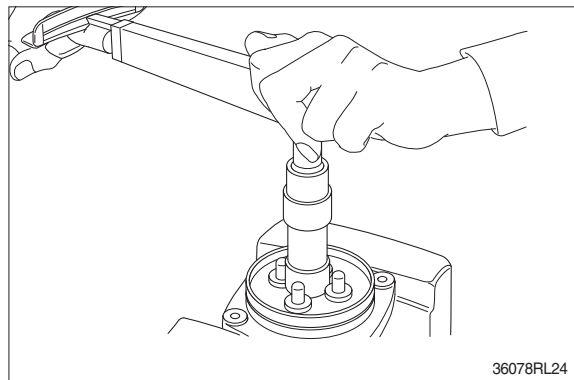

(10) Assemble swash plate (16) to joint (15).

- ※ Screw it to position that it contacts with 4 push rods evenly.
- ※ Do not screw it over.

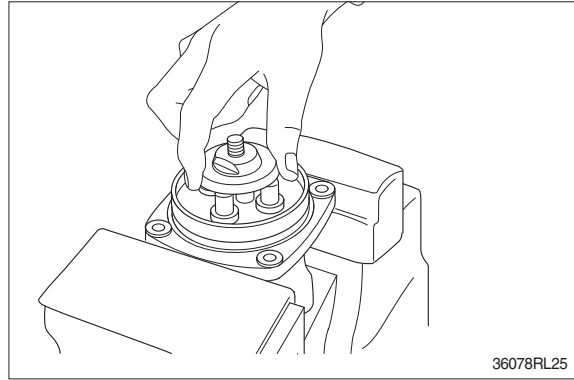

(11) Assemble adjusting nut (17), apply spanner to width across flat of plate (16) to fix it, and tighten adjusting nut to the specified torque.

- ※ During tightening, do not change position of disk.

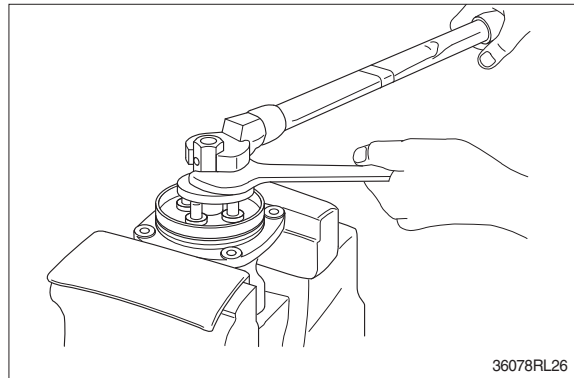

(12) Fit boot (14) to plate.

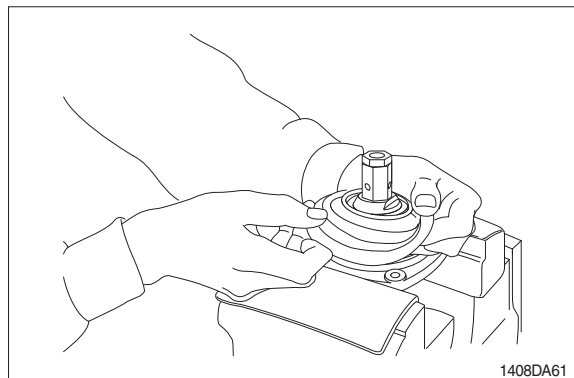

(13) Fit boot (23) and lock nut (22), and handle subassembly is assembled completely.

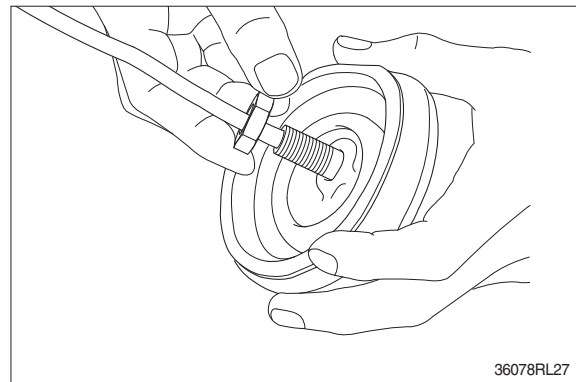
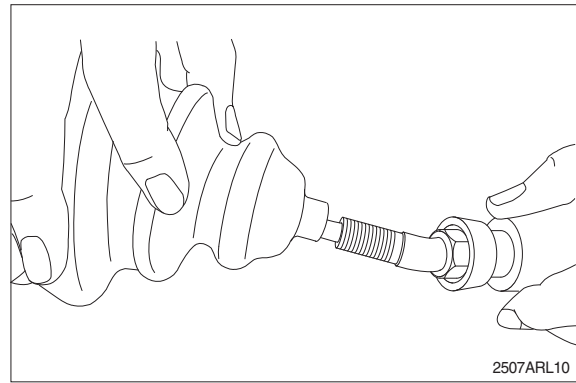

(14) Pull out cord and tube through adjusting nut hole provided in direction 60° to 120° from casing hole.

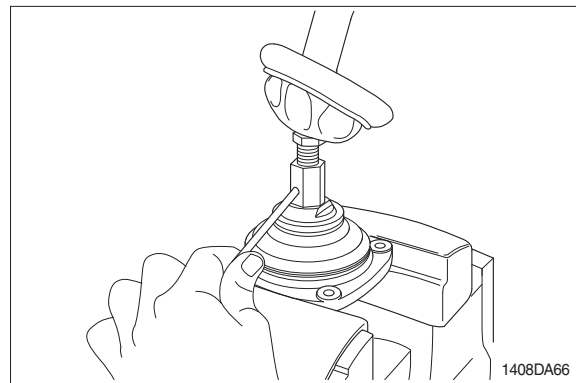

(15) Assemble bushing (18) to plate and pass cord and tube through it.
※ Provide margin necessary to operation.

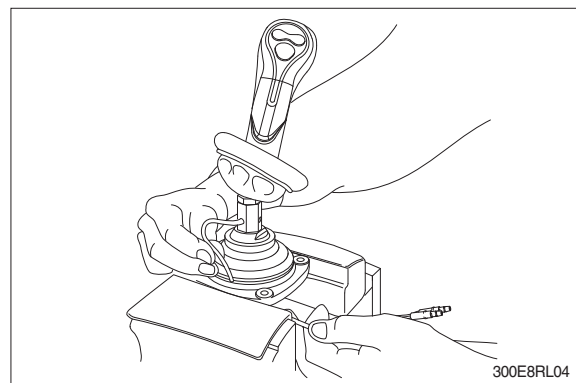

(16) Determine handle direction, tighten lock nut (22) to specified torque to fix handle.

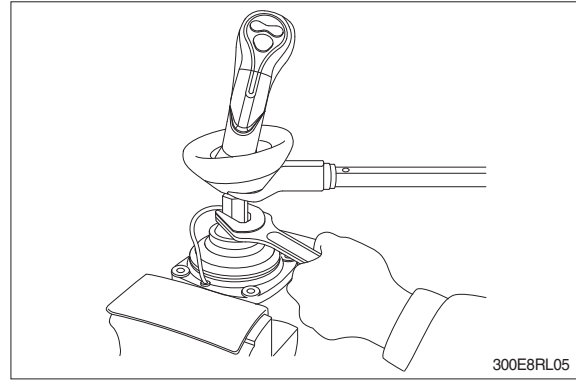

(17) Apply grease to rotating section of joint and contacting faces of disk and push rod.

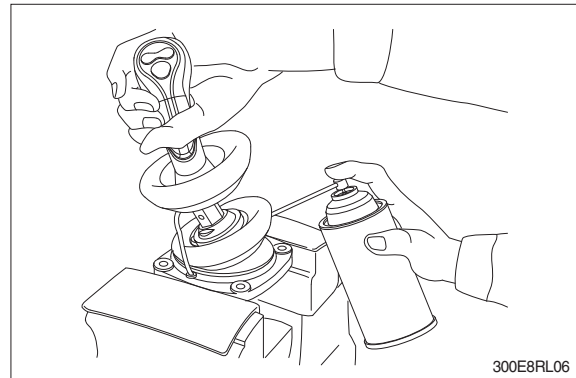

(18) Assemble lower end of bellows to casing.
(19) Inject volatile rust-preventives through all ports and then put blind plugs in ports.

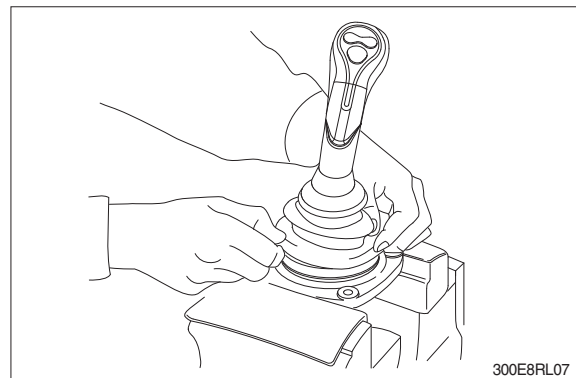

GROUP 8 TURNING JOINT

1. REMOVAL AND INSTALL

1) REMOVAL

- (1) Lower the work equipment to the ground and stop the engine.
- (2) Operate the control levers and pedals several times to release the remaining pressure in the hydraulic piping.
- (3) Loosen the breather slowly to release the pressure inside the hydraulic tank.

▲ Escaping fluid under pressure can penetrate the skin causing serious injury.

※ When pipes and hoses are disconnected, the oil inside the piping will flow out, so catch it in oil pan.

- (4) Disconnect all hoses.
- (5) Sling the turning joint assembly (1) and remove the mounting bolt (2).
 - Weight : 57 kg (125 lb)
 - Tightening torque : $12.3 \pm 1.3 \text{ kgf} \cdot \text{m}$
($90.0 \pm 9.4 \text{ lbf} \cdot \text{ft}$)

- (6) Remove the turning joint assembly.
 - ※ When removing the turning joint, check that all the hoses have been disconnected.

2) INSTALL

- (1) Carry out installation in the reverse order to removal.
 - ※ Take care of turning joint direction.
 - ※ Assemble hoses to their original positions.
 - ※ Confirm the hydraulic oil level and check the hydraulic oil leak or not.

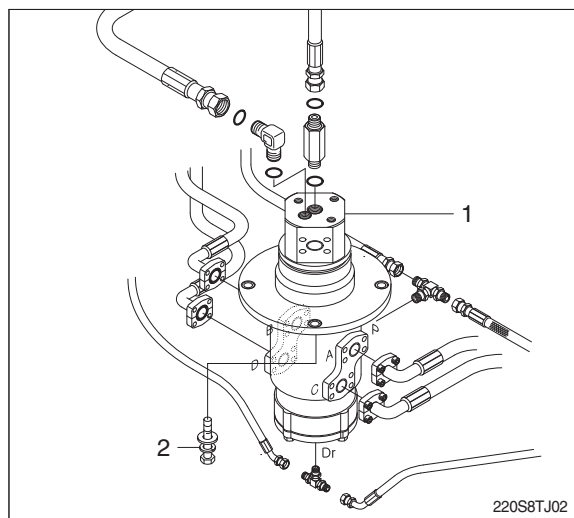
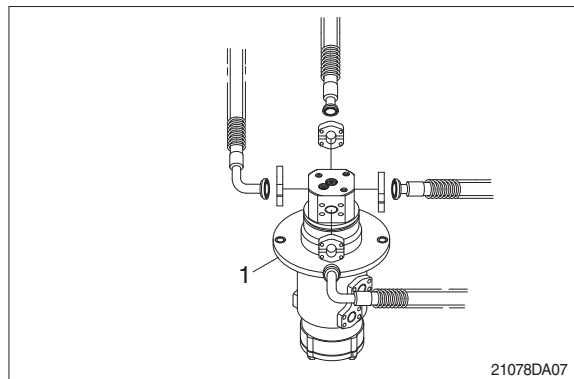

2. DISASSEMBLY AND ASSEMBLY

1) STRUCTURE

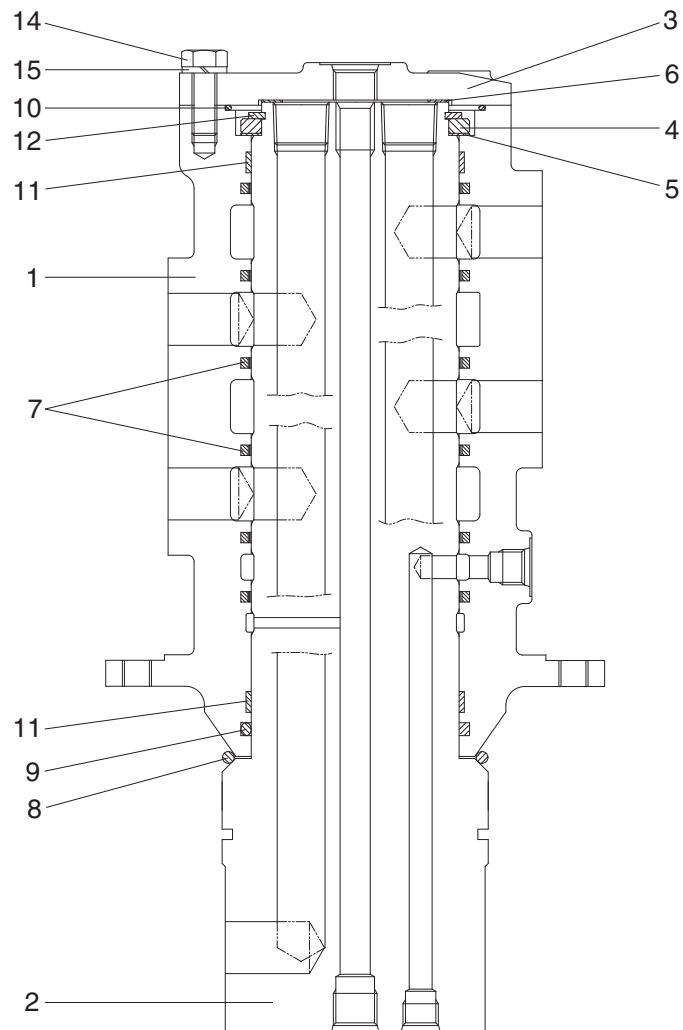

21098TJ01

- | | | | | | |
|---|--------|----|--------------|----|---------------|
| 1 | Hub | 6 | Shim | 11 | Wear ring |
| 2 | Shaft | 7 | Slipper seal | 12 | Retainer ring |
| 3 | Cover | 8 | O-ring | 13 | Plug |
| 4 | Spacer | 9 | O-ring | 14 | Hexagon bolt |
| 5 | Shim | 10 | O-ring | 15 | Spring washer |

2) DISASSEMBLY

※ Before the disassembly, clean the turning joint.

- (1) Remove bolts (14), washer (15) and cover (3).

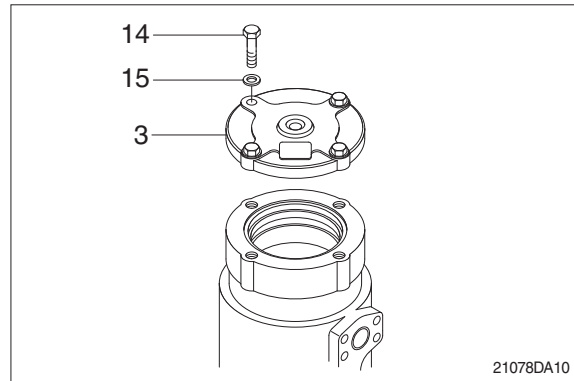

- (2) Remove shim (6) and O-ring (10).

- (3) Remove retainer ring (12), spacer (4) and shim (5).

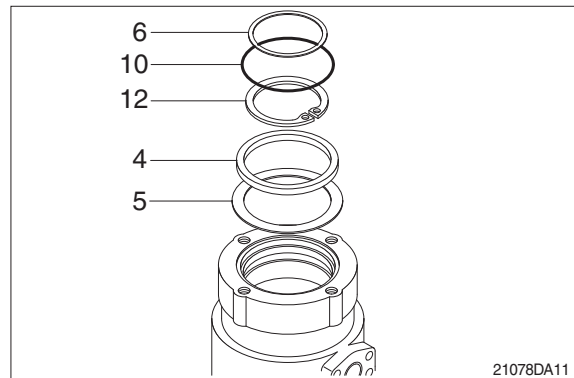

- (4) Place hub (1) on a V-block and by using a wood buffer at the shaft end, hit out shaft (2) to about 1/2 from the body with a hammer.

※ Take care not to damage the shaft (2) when remove hub (1) or rest it sideways.

※ Put a fitting mark on hub (1) and shaft (2).

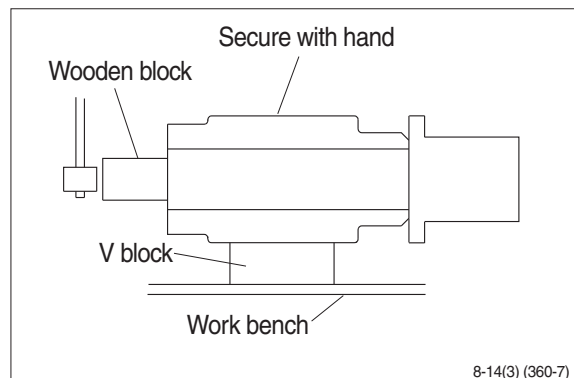

- (5) Remove six slipper seals (7) and O-ring (9), two wear ring (11) from hub (1).

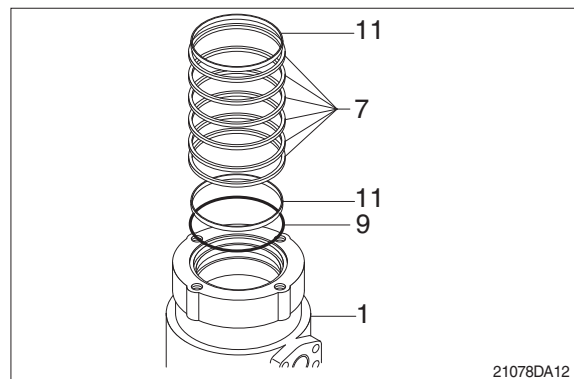

3) ASSEMBLY

- ※ Clean all parts.
- ※ As a general rule, replace oil seals and O-ring.
- ※ Coat the sliding surfaces of all parts with engine oil or grease before installing.

- (1) Fix seven slipper seal (7) and O-ring (9), two wear ring (11) to hub (1).
- (2) Fit O-ring (8) to shaft (2).

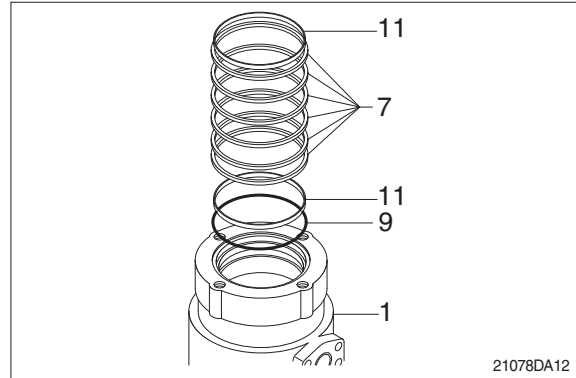

- (3) Set shaft (2) on block, tap hub (1) with a plastic hammer to install.

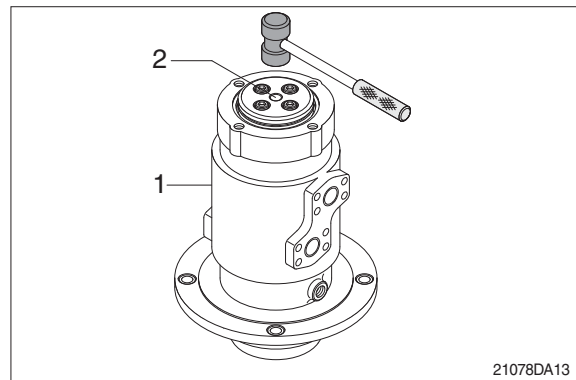

- (4) Fit shim (5), spacer (4) and retainer ring (12) to shaft (2).
- (5) Fit O-ring (10) to hub (1).
- (6) Fit shim (6) to shaft (2).

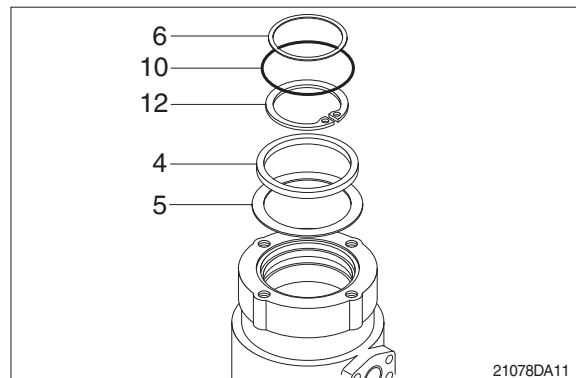

- (7) Install cover (3) to body (1) and tighten bolts (14).
- Torque : 10~12.5 kgf · m
(72.3~90.4 lbf · ft)

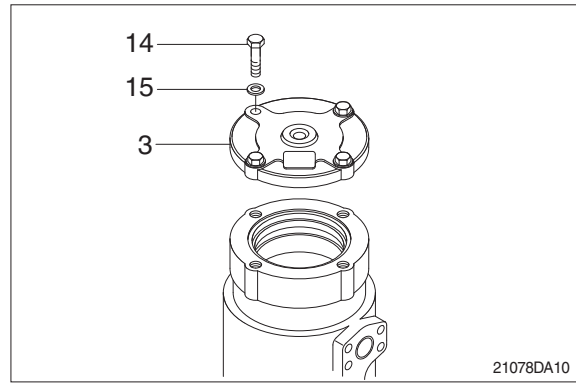

GROUP 9 BOOM, ARM AND BUCKET CYLINDER

1. REMOVAL AND INSTALL

1) BUCKET CYLINDER

(1) Removal

- ※ Expand the arm and bucket fully, lower the work equipment to the ground and stop the engine.
- ※ Operate the control levers and pedals several times to release the remaining pressure in the hydraulic piping.
- ※ Loosen the breather slowly to release the pressure inside the hydraulic tank.

▲ Escaping fluid under pressure can penetrate the skin causing serious injury.

- ※ Fit blind plugs in the hoses after disconnecting them, to prevent dirt or dust from entering.

- ① Set block between bucket cylinder and arm.

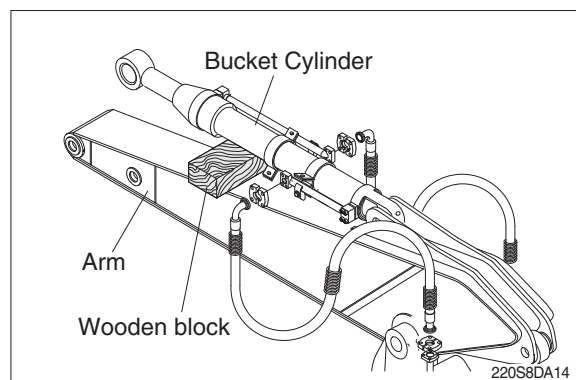

- ② Remove bolt (2), nut (3) and pull out pin (1).

- ※ Tie the rod with wire to prevent it from coming out.

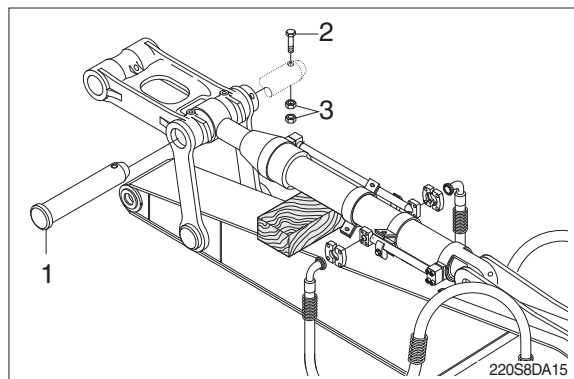

- ③ Disconnect bucket cylinder hoses (4) and put plugs (5) on cylinder pipe.

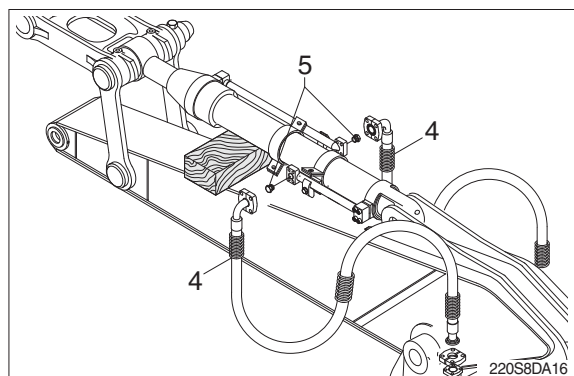

- ④ Sling bucket cylinder assembly (8) and remove bolt (6) then pull out pin (5).
- ⑤ Remove bucket cylinder assembly (8).
 - Weight : 175 kg (390 lb)

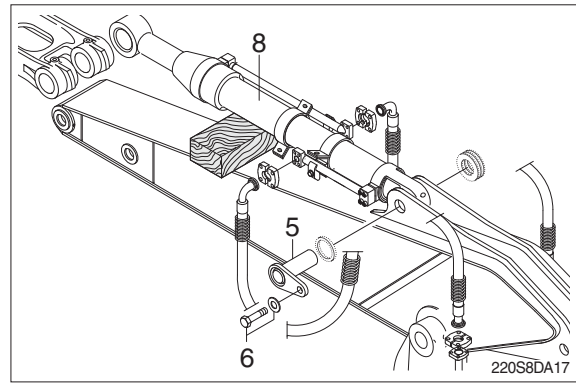

(2) Install

- ① Carry out installation in the reverse order to removal.
- ▲ When aligning the mounting position of the pin, do not insert your fingers in the pin hole.**
- ※ Bleed the air from the bucket cylinder.
 - ※ Confirm the hydraulic oil level and check the hydraulic oil leak or not.

2) ARM CYLINDER

(1) Removal

- ※ Expand the arm and bucket fully, lower the work equipment to the ground and stop the engine.
- ※ Operate the control levers and pedals several times to release the remaining pressure in the hydraulic piping.
- ※ Loosen the breather slowly to release the pressure inside the hydraulic tank.

▲ Escaping fluid under pressure can penetrate the skin causing serious injury.

- ※ Fit blind plugs in the hoses after disconnecting them, to prevent dirt or dust from entering.
- ① Set block between arm cylinder and boom.

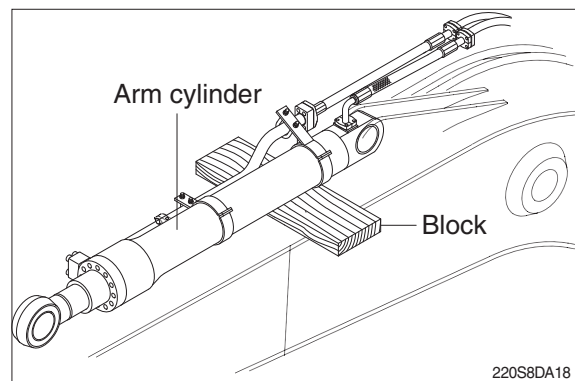

- ② Remove bolt (2) and pull out pin (1).
- ※ Tie the rod with wire to prevent it from coming out.

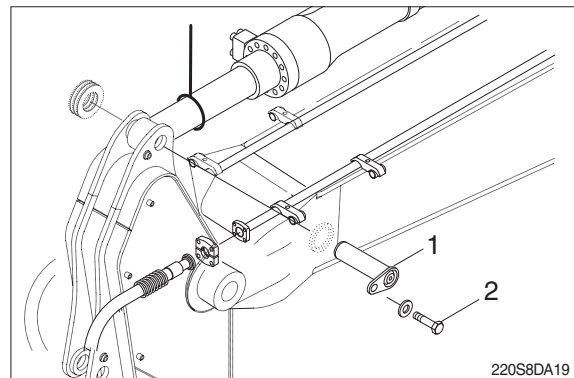

- ③ Disconnect arm cylinder hoses (4) and put plugs on cylinder pipe.
- ④ Disconnect greasing pipings (5).

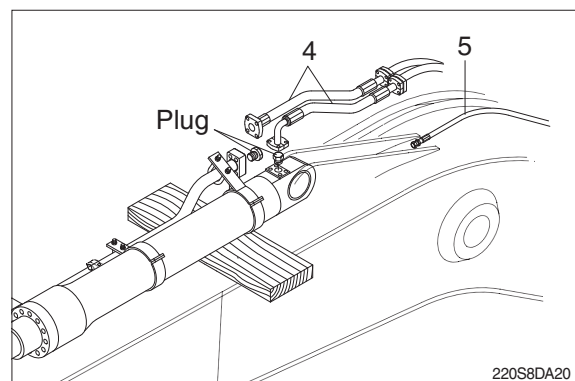

- ⑤ Sling arm cylinder assembly(8) and remove bolt (7) then pull out pin (6).
- ⑥ Remove arm cylinder assembly (8).
 - Weight : 290 kg (640 lb)

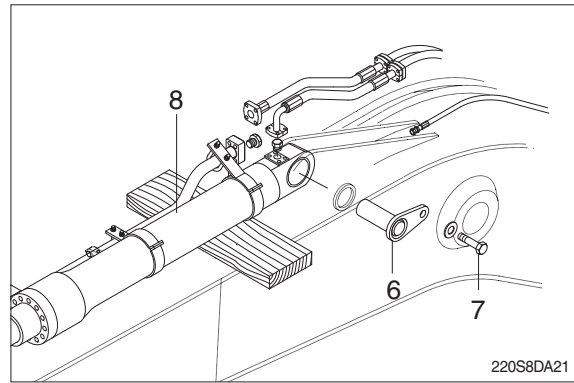

(2) Install

- ① Carry out installation in the reverse order to removal.
- ▲ When aligning the mounting position of the pin, do not insert your fingers in the pin hole.**
- ※ Bleed the air from the arm cylinder.
 - ※ Confirm the hydraulic oil level and check the hydraulic oil leak or not.

3) BOOM CYLINDER

(1) Removal

- ※ Expand the arm and bucket fully, lower the work equipment to the ground and stop the engine.
- ※ Operate the control levers and pedals several times to release the remaining pressure in the hydraulic piping.
- ※ Loosen the breather slowly to release the pressure inside the hydraulic tank.

▲ Escaping fluid under pressure can penetrate the skin causing serious injury.

- ※ Fit blind plugs in the hoses after disconnecting them, to prevent dirt or dust from entering.
- ① Disconnect greasing hoses (1).
 - ② Sling boom cylinder assembly.

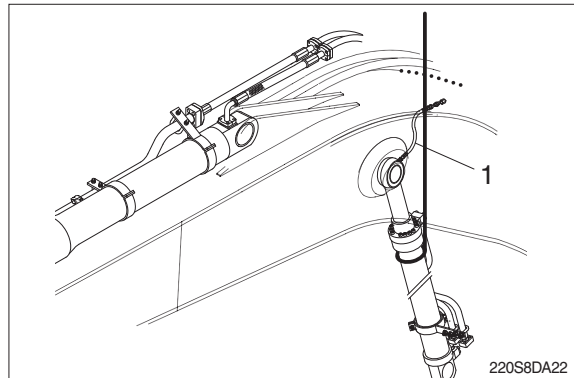

- ③ Remove bolt (4), stopper (5) and pull out pin (2).
- ※ Tie the rod with wire to prevent it from coming out.

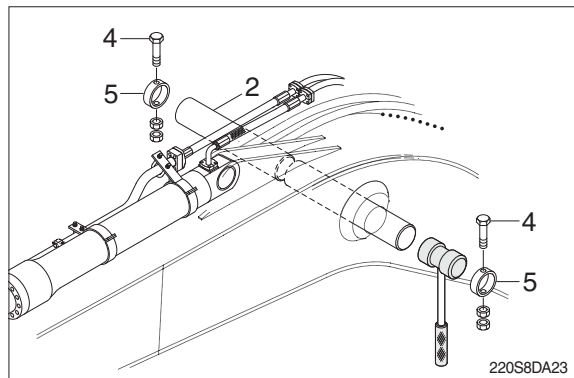

- ④ Lower the boom cylinder assembly (6) on a stand.

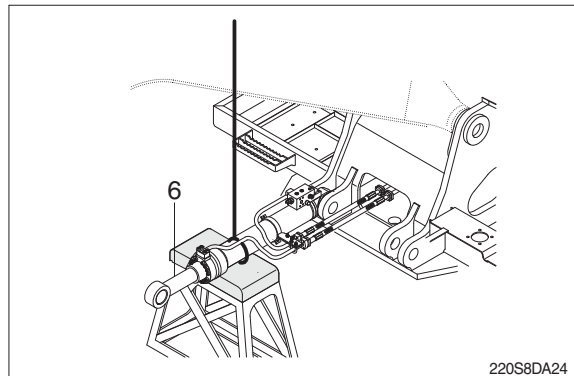

- ⑤ Disconnect boom cylinder hoses (7) and put plugs on cylinder pipe.

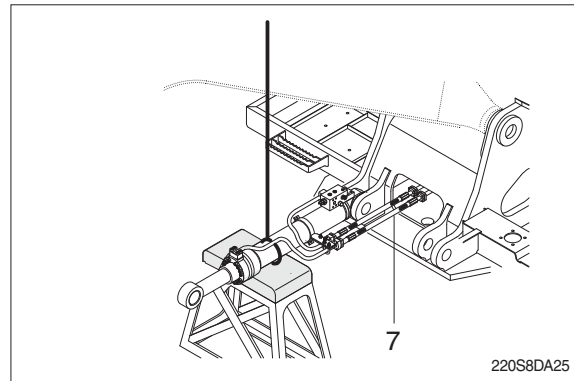

- ⑥ Remove bolt (9) and pull out pin (8).
⑦ Remove boom cylinder assembly (6).
· Weight : 198 kg (436 lb)

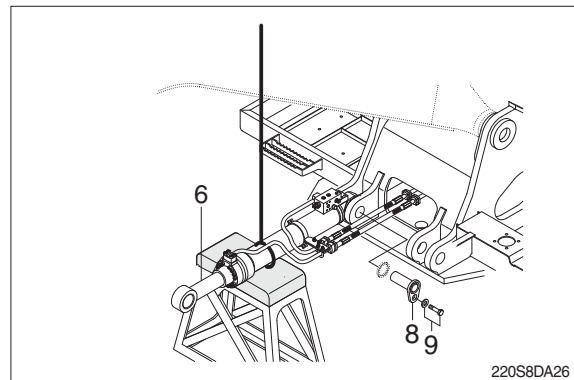

(2) Install

- ① Carry out installation in the reverse order to removal.
- ▲ When aligning the mounting position of the pin, do not insert your fingers in the pin hole.**
- ※ Bleed the air from the boom cylinder.
 - ※ Confirmed the hydraulic oil level and check the hydraulic oil leak or not.

2. DISASSEMBLY AND ASSEMBLY

1) STRUCTURE

(1) Bucket cylinder

① Standard

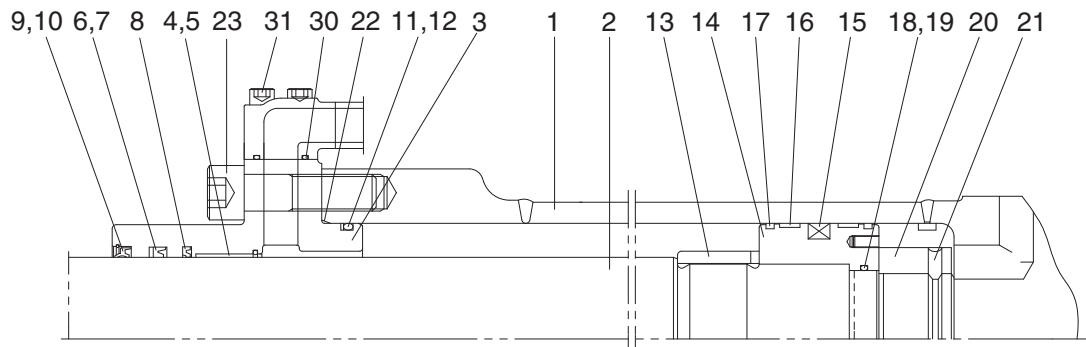

Internal detail

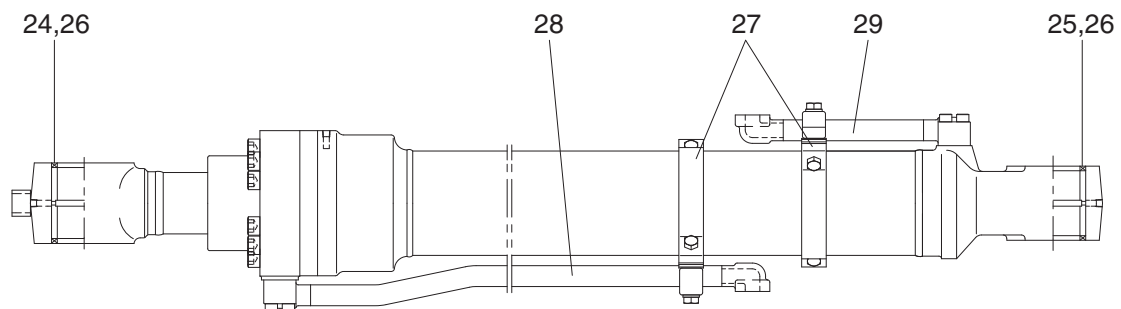

21098CY01

1	Tube assembly	12	Back up ring	23	Hexagon socket head bolt
2	Rod assembly	13	Cushion ring	24	Pin bushing
3	Gland	14	Piston	25	Pin bushing
4	DD2 bushing	15	Piston seal	26	Dust seal
5	Snap ring	16	Wear ring	27	Band assembly
6	Rod seal	17	Dust ring	28	Pipe assembly-R
7	Back up ring	18	O-ring	29	Pipe assembly-B
8	Buffer ring	19	Back up ring	30	O-ring
9	Dust wiper	20	Lock nut	31	Hexagon socket head bolt
10	Snap ring	21	Hexagon socket set screw		
11	O-ring	22	O-ring		

② Long reach

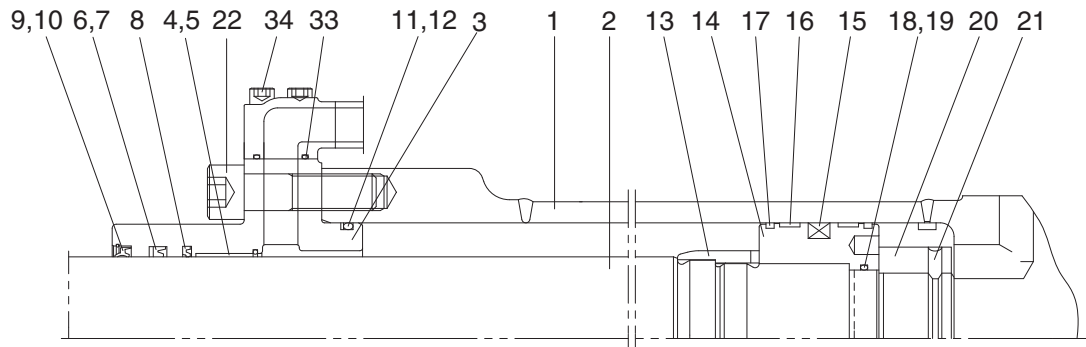

Internal detail

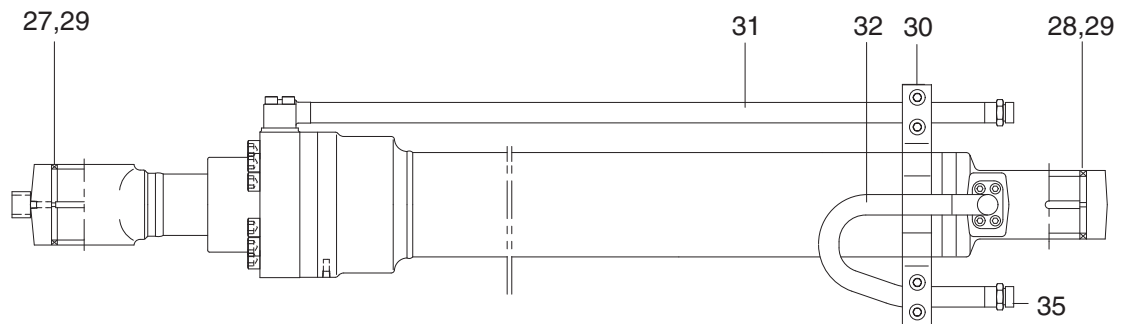

31Q6-66102GG

- | | | | | | |
|----|---------------|----|--------------------------|----|--------------------------|
| 1 | Tube assembly | 12 | Back up ring | 27 | Pin bushing |
| 2 | Rod assembly | 13 | Cushion ring | 28 | Pin bushing |
| 3 | Gland | 14 | Piston | 29 | Dust seal |
| 4 | DD2 bushing | 15 | Piston seal | 30 | Band assembly |
| 5 | Snap ring | 16 | Wear ring | 31 | Pipe assembly-R |
| 6 | Rod seal | 17 | Dust ring | 32 | Pipe assembly-B |
| 7 | Back up ring | 18 | O-ring | 33 | O-ring |
| 8 | Buffer ring | 19 | Back up ring | 34 | Hexagon socket head bolt |
| 9 | Dust wiper | 20 | Lock nut | 35 | O-ring |
| 10 | Snap ring | 21 | Hexagon socket set screw | | |
| 11 | O-ring | 22 | Hexagon socket head bolt | | |

(2) Arm cylinder

① Without safety valve

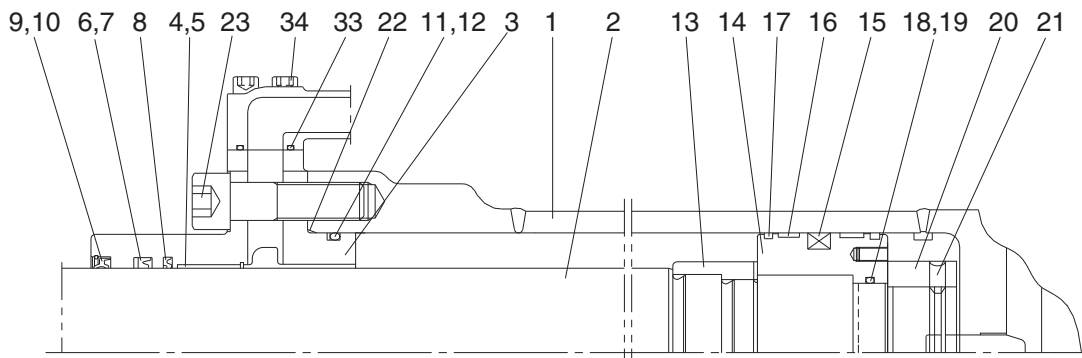

Internal detail

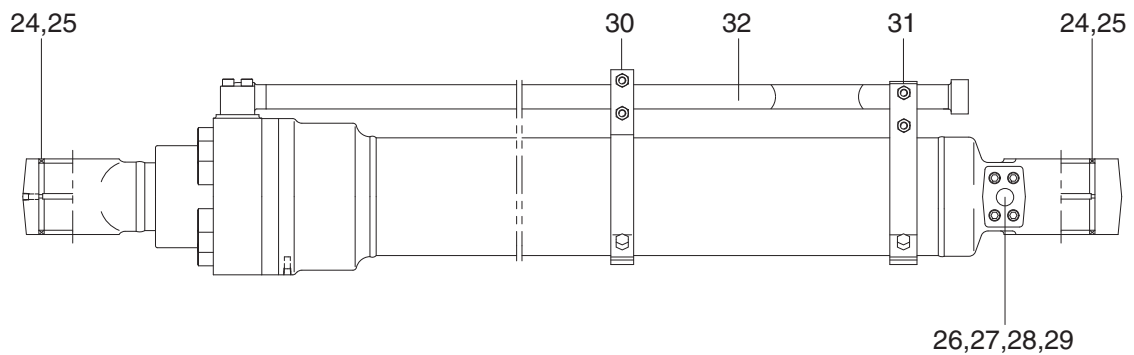

21098CY02

1	Tube assembly	13	Cushion ring	25	Dust seal
2	Rod assembly	14	Piston	26	Check valve
3	Gland	15	Piston seal	27	Coil spring
4	DD2 bushing	16	Wear ring	28	O-ring
5	Snap ring	17	Dust ring	29	Plug
6	Rod seal	18	O-ring	30	Band assembly-R
7	Back up ring	19	Back up ring	31	Band assembly-B
8	Buffer ring	20	Lock nut	32	Pipe assembly-R
9	Dust wiper	21	Hexagon socket set screw	33	O-ring
10	Snap ring	22	O-ring	34	Hexagon socket head bolt
11	O-ring	23	Hexagon socket head bolt		
12	Back up ring	24	Pin bushing		

② With safety valve

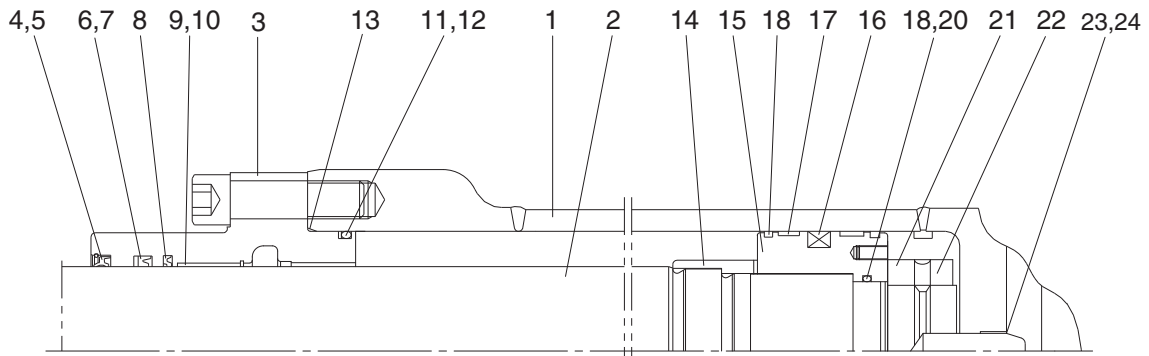

Internal detail

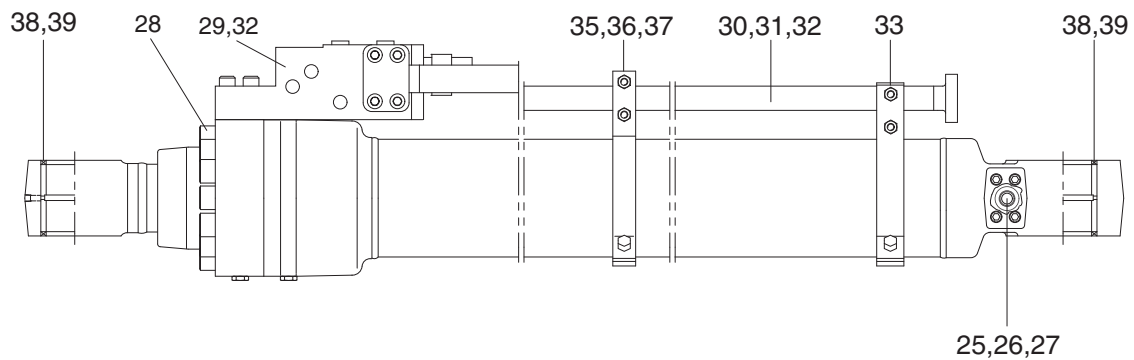

31K6-52130E

- | | | | | | |
|----|----------------|----|--------------------------|----|--------------------------|
| 1 | Tube assembly | 14 | Cushion ring | 27 | Plug |
| 2 | Rod assembly | 15 | Piston | 28 | Hexagon socket head bolt |
| 3 | Gland | 16 | Piston seal | 29 | Safety lock valve |
| 4 | Dust wiper | 17 | Wear ring | 30 | Pipe assembly-RV |
| 5 | Retaining ring | 18 | Dust ring | 31 | O-ring |
| 6 | Rod seal | 19 | O-ring | 32 | Hexagon socket head bolt |
| 7 | Back up ring | 20 | Back up ring | 33 | Band assembly-B |
| 8 | Buffer ring | 21 | Lock nut | 34 | Band assembly-R |
| 9 | Dry bearing | 22 | Hexagon socket set screw | 35 | U-bolt |
| 10 | Retaining ring | 23 | Cushion spear | 36 | Hexagon nut |
| 11 | O-ring | 24 | Stop ring | 37 | Spring washer |
| 12 | Back up ring | 25 | Check valve | 38 | Pin bushing |
| 13 | O-ring | 26 | Coil spring | 39 | Dust seal |

(3) Boom cylinder

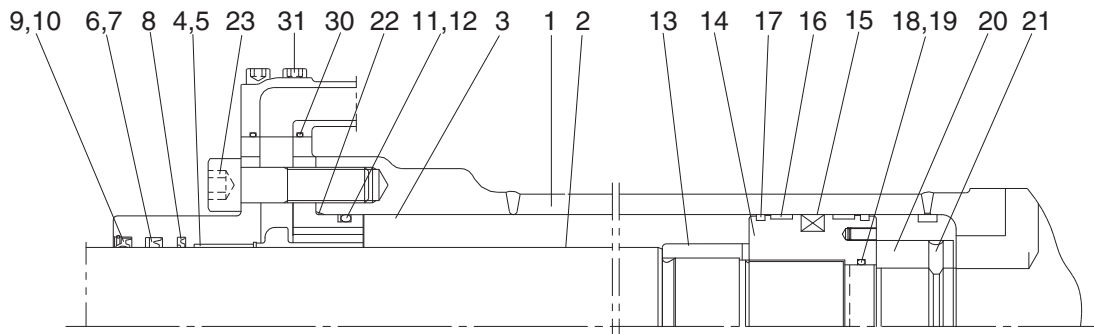

Internal detail

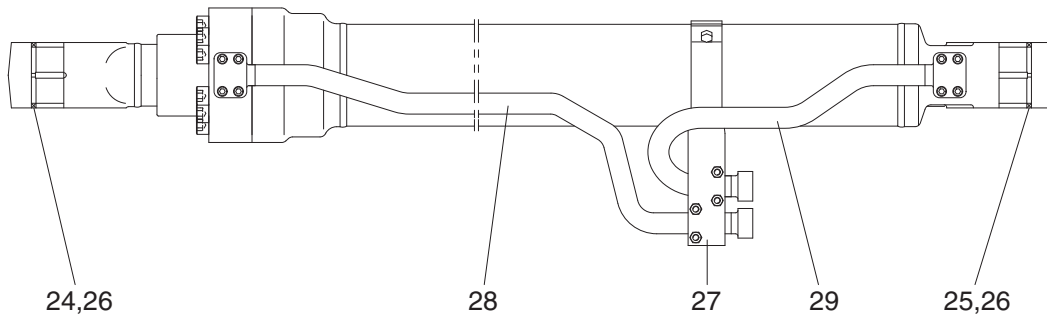

21098CY03

- | | | | | | |
|----|---------------|----|--------------------------|----|--------------------------|
| 1 | Tube assembly | 12 | Back up ring | 23 | Hexagon socket head bolt |
| 2 | Rod assembly | 13 | Cushion ring | 24 | Pin bushing |
| 3 | Gland | 14 | Piston | 25 | Pin bushing |
| 4 | DD2 bushing | 15 | Piston seal | 26 | Dust seal |
| 5 | Snap ring | 16 | Wear ring | 27 | Band assembly |
| 6 | Rod seal | 17 | Dust ring | 28 | Pipe assembly-R |
| 7 | Back up ring | 18 | O-ring | 29 | Pipe assembly-B |
| 8 | Buffer ring | 19 | Back up ring | 30 | O-ring |
| 9 | Dust wiper | 20 | Lock nut | 31 | Hexagon socket head bolt |
| 10 | Snap ring | 21 | Hexagon socket set screw | | |
| 11 | O-ring | 22 | O-ring | | |

2) TOOLS AND TIGHTENING TORQUE

(1) Tools

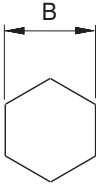
Tools	Remark	
Allen wrench	4	
	5	
	8	
	10	
	14	
Spanner	7	
	8	
(-) Driver	Small and large sizes	
Torque wrench	Capable of tightening with the specified torques	

(2) Tightening torque

Part name		Item	Size	Torque	
				kgf · m	lbf · ft
Socket head bolt	Bucket cylinder	★1 23	M16	23 ± 2.0	166 ± 14.5
		31	M10	5.4 ± 0.5	39.1 ± 3.6
	Boom cylinder	★1 23	M16	23 ± 2.0	166 ± 14.5
		31	M10	5.4 ± 0.5	39.1 ± 3.6
	Arm cylinder	★1 23	M18	32 ± 3.0	232 ± 21.7
34		M12	9.4 ± 1.0	68 ± 7.2	
Lock nut	Bucket cylinder	20	-	100 ± 10	723 ± 72.3
	Boom cylinder	20	-	100 ± 10	723 ± 72.3
	Arm cylinder	20	-	150 ± 15	1085 ± 108
Piston	Bucket cylinder	14	-	150 ± 15	1085 ± 108
	Boom cylinder	14	-	150 ± 15	1085 ± 108
	Arm cylinder	14	-	200 ± 20	1447 ± 145
Socket set screw	Bucket cylinder	21	M8	2.7 ± 0.3	19.5 ± 2.2
	Boom cylinder	21	M8	2.7 ± 0.3	19.5 ± 2.2
	Arm cylinder	21	M10	5.4 ± 0.5	39.1 ± 3.6

★1 : Apply loctite #243 on the thread of bolt.

3) DISASSEMBLY

(1) Remove cylinder head and piston rod

※ Procedures are based on the bucket cylinder.

① Hold the clevis section of the tube in a vise.

※ Use mouth pieces so as not to damage the machined surface of the cylinder tube. Do not make use of the outside piping as a locking means.

② Pull out rod assembly (2) about 200 mm (7.1 in). Because the rod assembly is rather heavy, finish extending it with air pressure after the oil draining operation.

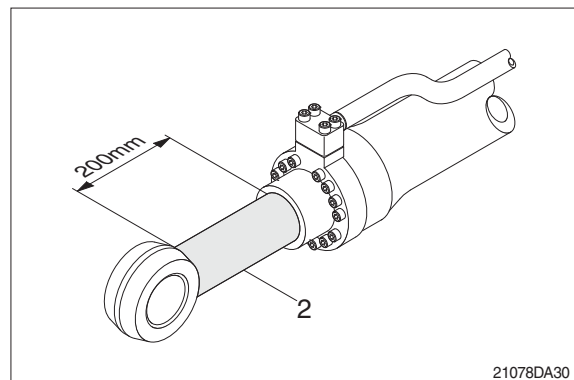

③ Loosen and remove socket bolts (23) of the gland in sequence.

※ Cover the extracted rod assembly (2) with rag to prevent it from being accidentally damaged during operation.

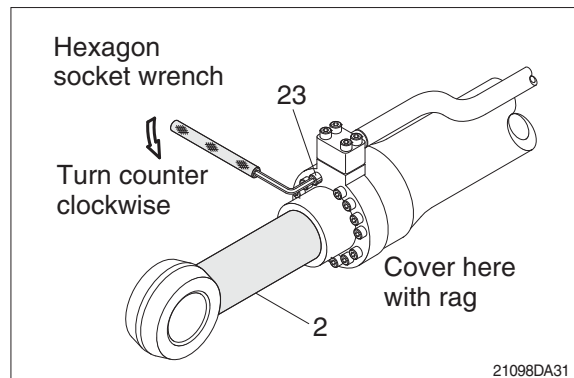

④ Draw out cylinder head and rod assembly together from tube assembly (1).

※ Since the rod assembly is heavy in this case, lift the tip of the rod assembly (2) with a crane or some means and draw it out. However, when rod assembly (2) has been drawn out to approximately two thirds of its length, lift it in its center to draw it completely.

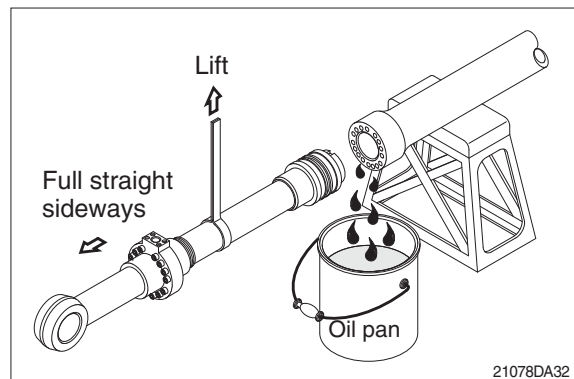

Note that the plated surface of rod assembly (2) is to be lifted. For this reason, do not use a wire sling and others that may damage it, but use a strong cloth belt or a rope.

- ⑤ Place the removed rod assembly on a wooden V-block that is set level.
- ※ Cover a V-block with soft rag.

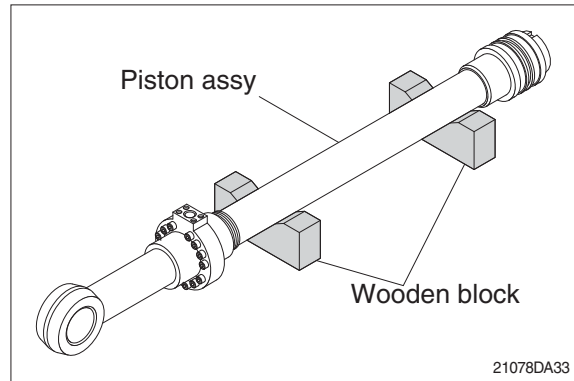

(2) Remove piston and cylinder head

- ① Remove set screw (21).
- ② Remove lock nut (20).
- ※ Since piston (14) and lock nut (20) are tightened to a high torque, use a hydraulic and power wrench that utilizes a hydraulic cylinder, to remove the piston (14) and lock nut (20).
- ③ Remove piston assembly (14), back up ring (19), and O-ring (18).
- ④ Remove cushion ring (13).

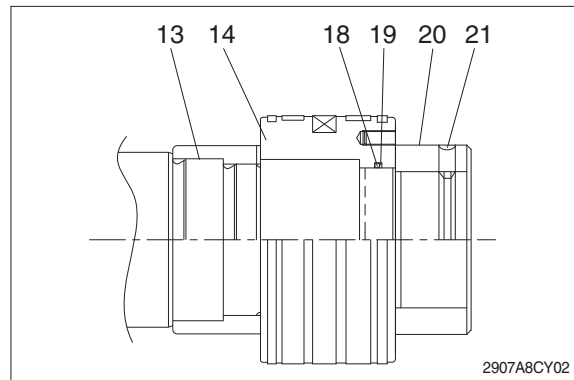

- ⑤ Remove the cylinder head assembly from rod assembly (2).
- ※ If it is too heavy to move, move it by striking the flanged part of cylinder head with a plastic hammer.
- ※ Pull it straight with cylinder head assembly lifted with a crane.

Exercise care so as not to damage the lip of rod bushing (4) and packing (5,6,7,8,9,10) by the threads of rod assembly (2).

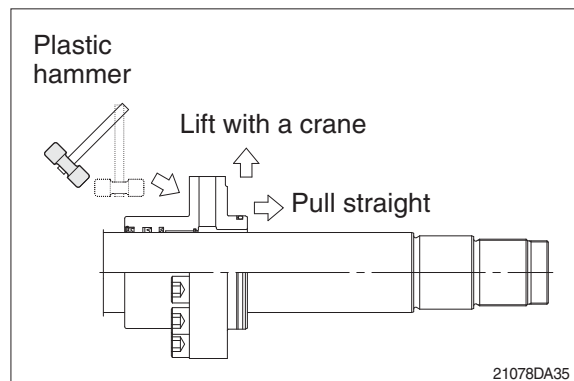

(3) Disassemble the piston assembly

- ① Remove wear ring (16).
 - ② Remove dust ring (17) and piston seal (15).
- ※ Exercise care in this operation not to damage the grooves.

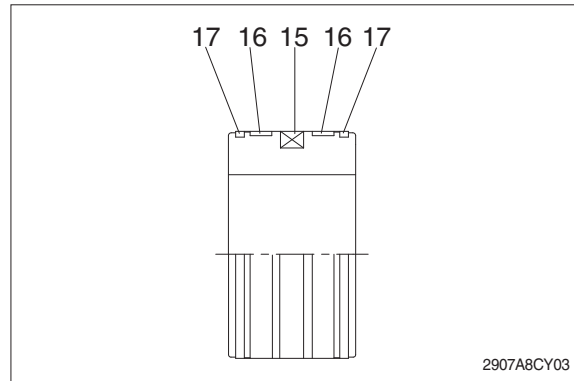

(4) Disassemble cylinder head assembly

- ① Remove back up ring (12), O-ring (11) and O-ring (22).
 - ② Remove snap ring (10), dust wiper (9).
 - ③ Remove back up ring (7), rod seal (6) and buffer ring (8).
- ※ Exercise care in this operation not to damage the grooves.
- ※ Do not remove seal and ring, if does not damaged.
- ※ Do not remove bushing (4).

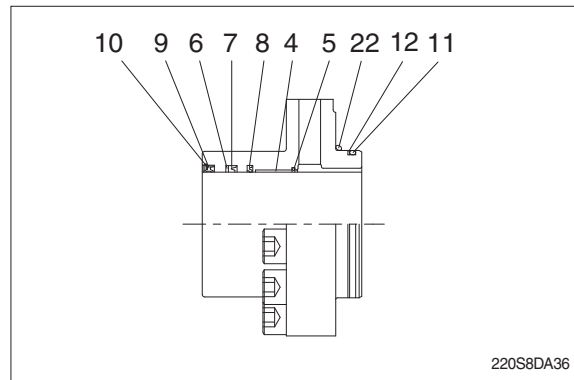

3) ASSEMBLY

(1) Assemble cylinder head assembly

※ Check for scratches or rough surfaces if found smooth with an oil stone.

① Coat the inner face of gland (3) with hydraulic oil.

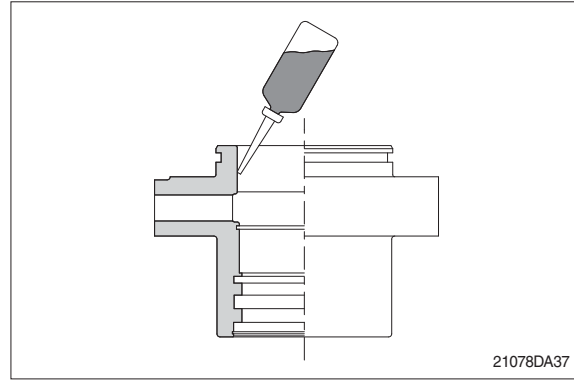

② Coat dust wiper (9) with grease and fit dust wiper (9) to the bottom of the hole of dust seal.

At this time, press a pad metal to the metal ring of dust seal.

③ Fit snap ring (10) to the stop face.

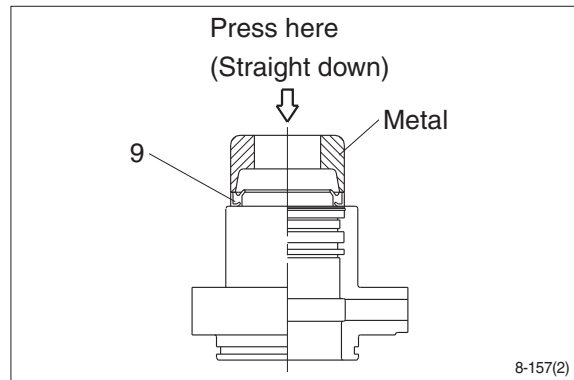

④ Fit back up ring (7), rod seal (6) and buffer ring (8) to corresponding grooves, in that order.

※ Coat each packing with hydraulic oil before fitting it.

※ Insert the backup ring until one side of it is inserted into groove.

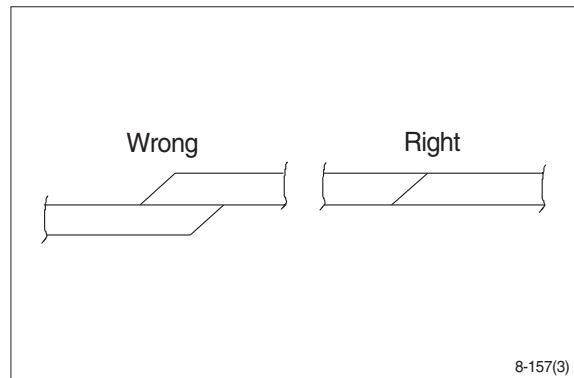

※ Rod seal (6) has its own fitting direction. Therefore, confirm it before fitting them.

※ Fitting rod seal (6) upside down may damage its lip. Therefore check the correct direction that is shown in fig.

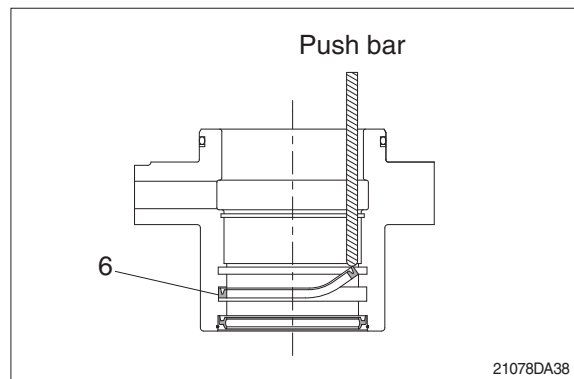

- ⑤ Fit back up ring (12) to gland (3).
- ※ Put the backup ring in the warm water of 30~50°C.
- ⑥ Fit O-ring (11) and O-ring (22) to gland (3).

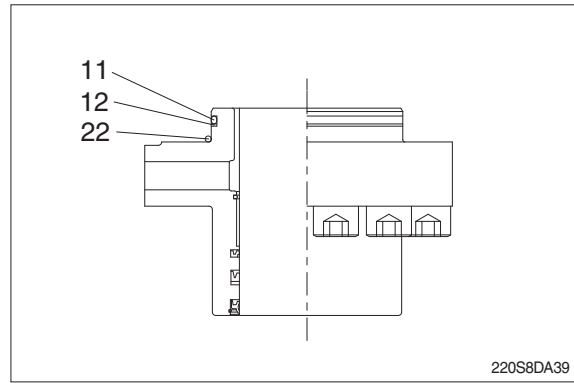

(2) Assemble piston assembly

- ※ Check for scratches or rough surfaces. If found smooth with an oil stone.
- ① Coat the outer face of piston (14) with hydraulic oil.

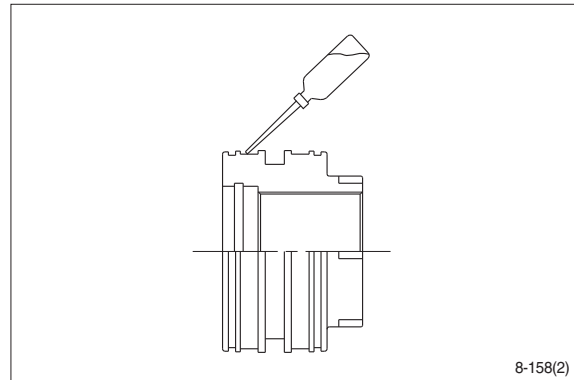

- ② Fit piston seal (15) to piston.
- ※ Put the piston seal in the warm water of 60~100°C for more than 5 minutes.
- ※ After assembling the piston seal, press its outer diameter to fit in.

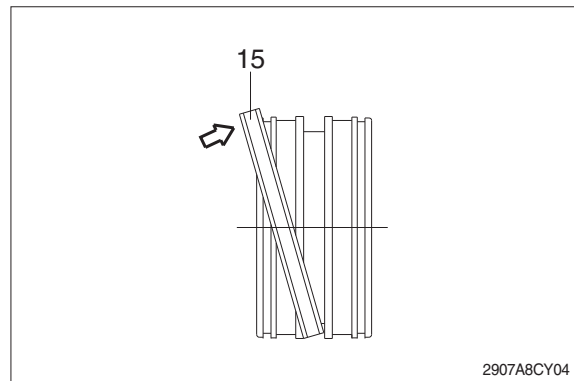

- ③ Fit wear ring (16) and dust ring (17) to piston (14).

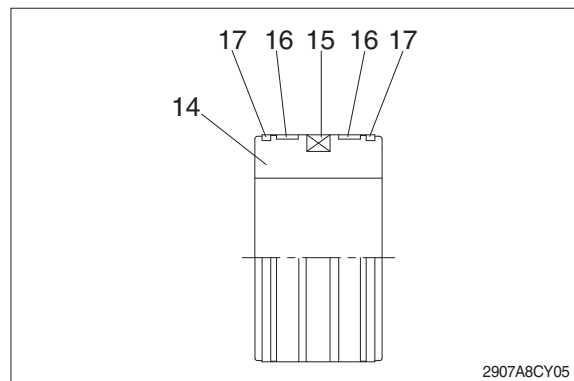

(3) Install piston and cylinder head

- ① Fix the rod assembly to the work bench.
- ② Apply hydraulic oil to the outer surface of rod assembly (2), the inner surface of piston and cylinder head.
- ③ Insert cylinder head assembly to rod assembly.

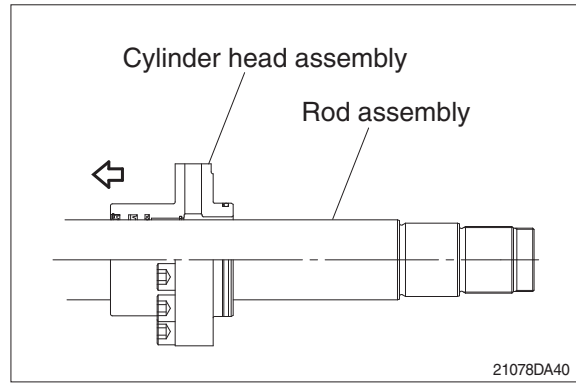

- ④ Insert cushion ring (13) to rod assembly.
- ※ Note that cushion ring (13) has a direction in which it should be fitted.

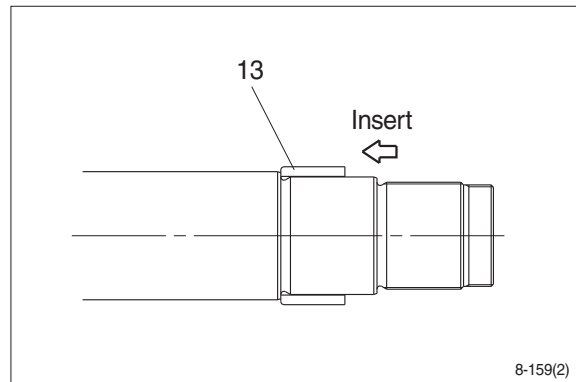

- ⑤ Fit piston assembly to rod assembly.
- Tightening torque :

	Item	kgf · m	lbf · ft
14	Bucket	150 ± 15	1085 ± 108
	Boom	150 ± 15	1085 ± 108
	Arm	200 ± 20	1447 ± 145

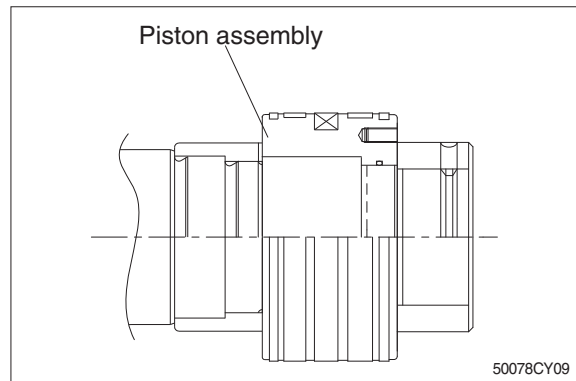

- ⑥ Fit lock nut (20) and tighten the screw (21).

· Tightening torque :

	Item	kgf · m	lbf · ft
20	Bucket	100 ± 10	723 ± 72.3
	Boom	100 ± 10	723 ± 72.3
	Arm	150 ± 15	1085 ± 108
21	Bucket	2.7 ± 0.3	19.6 ± 2.2
	Boom	2.7 ± 0.3	19.5 ± 2.2
	Arm	5.4 ± 0.5	39.1 ± 3.6

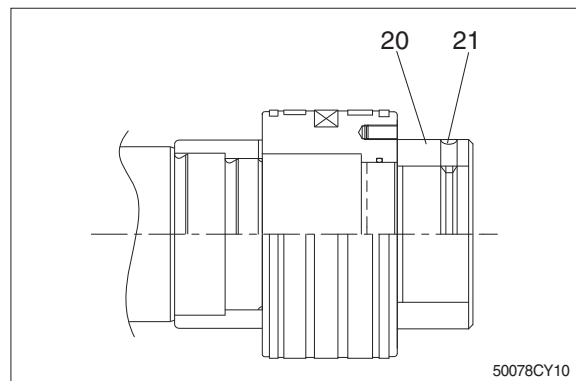

(3) Overall assemble

- ① Place a V-block on a rigid work bench.
Mount the tube assembly (1) on it and fix the assembly by passing a bar through the clevis pin hole to lock the assembly.
- ② Insert the rod assembly in to the tube assembly, while lifting and moving the rod assembly with a crane.
 - ※ Be careful not to damage piston seal by thread of tube assembly.
- ③ Match the bolt holes in the cylinder head flange to the tapped holes in the tube assembly and tighten socket bolts to a specified torque.
 - ※ Refer to the table of tightening torque.

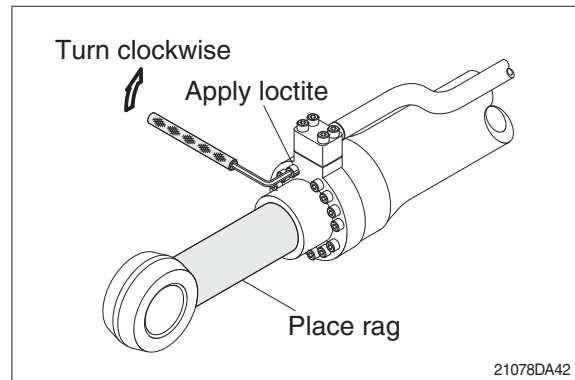
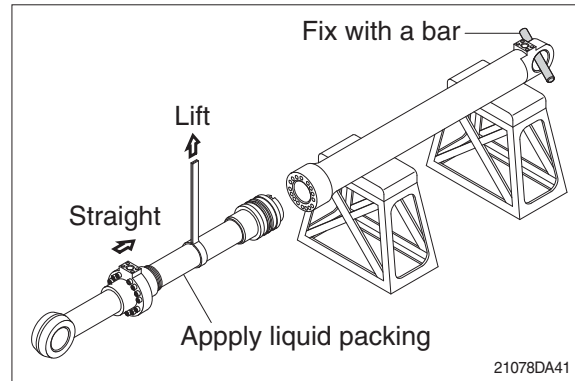

GROUP 10 UNDERCARRIAGE

1. TRACK LINK

1) REMOVAL

(1) Move track link until master pin is over front idler in the position put wooden block as shown.

(2) Loosen tension of the track link.

※ If track tension is not relieved when the grease valve is loosened, move the machine backwards and forwards.

※ Unscrew the grease nipple after release the tension by pushing the poppet only when necessarily required.

Grease leaking hole is not existing. So, while unscrew the grease nipple, grease is not leaking until the grease nipple is completely coming out. If the tension is not released in advance, the grease nipple can be suddenly popped out by pressurized grease.

(3) Push out master pin by using a suitable tool.

(4) Move the machine slowly in reverse, and lay out track link assembly (1).

※ Jack up the machine and put wooden block under the machine.

※ Don't get close to the sprocket side as the track shoe plate may fall down on your feet.

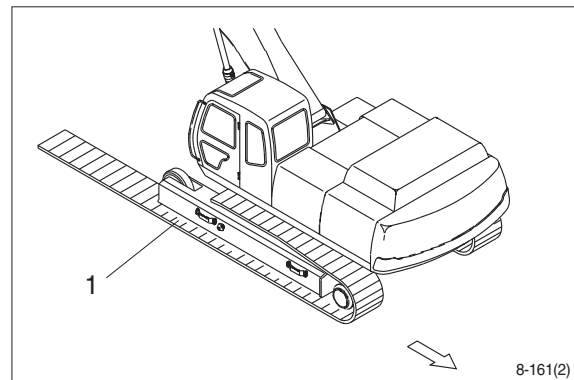
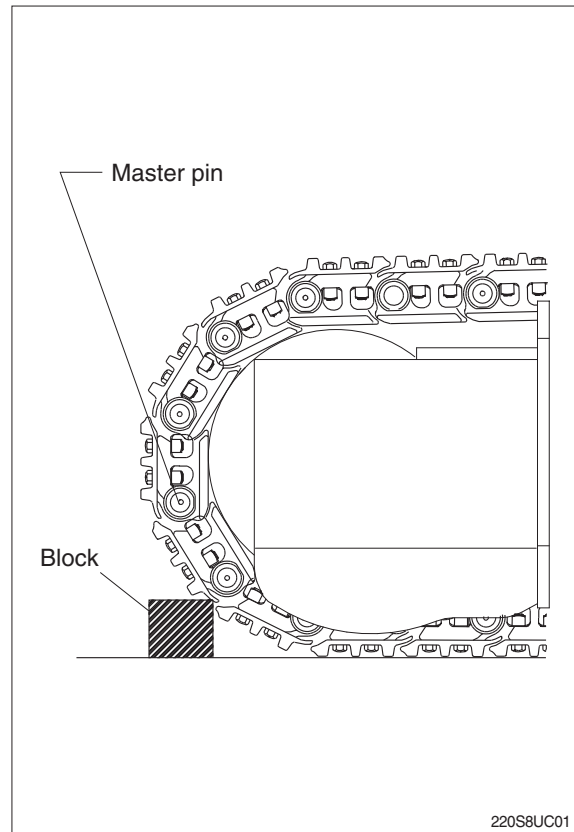

2) INSTALL

(1) Carry out installation in the reverse order to removal.

※ Adjust the tension of the track link.

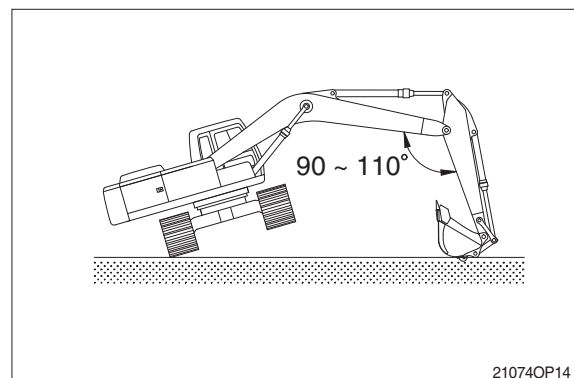

2. CARRIER ROLLER

1) REMOVAL

- (1) Loosen tension of the track link.

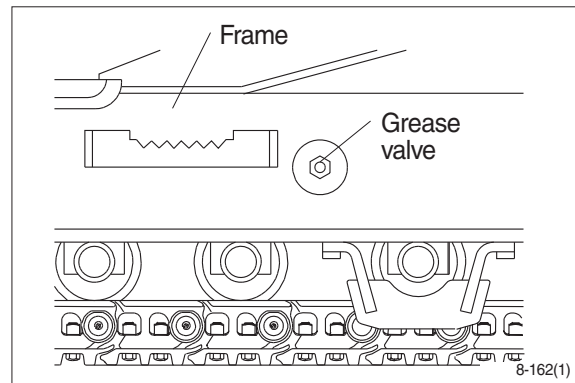

- (2) Jack up the track link height enough to permit carrier roller removal.

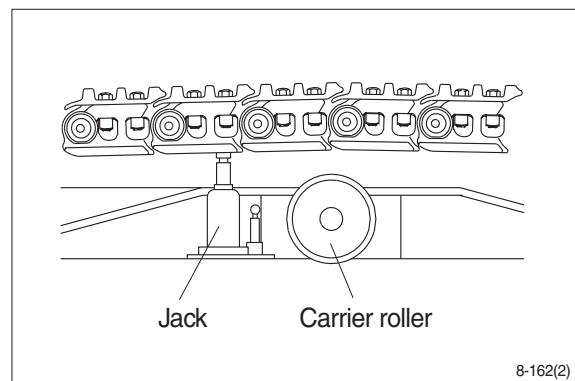

- (3) Loosen the lock nut (1).
- (4) Open bracket(2) with a screwdriver, push out from inside, and remove carrier roller assembly.
 - Weight : 21 kg (46 lb)
 - Tightening torque : 29.7 ± 4.5 kgf·m
(215 ± 32.5 lbf · ft)

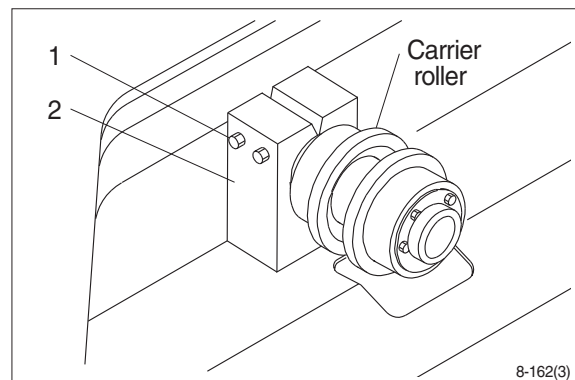

2) INSTALL

- (1) Carry out installation in the reverse order to removal.

3. TRACK ROLLER

1) REMOVAL

- (1) Loosen tension of the track link.

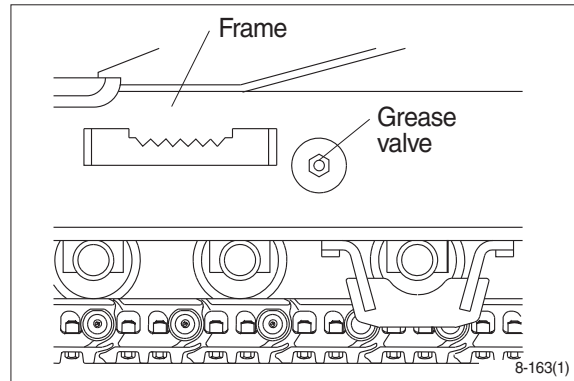

- (2) Using the work equipment, push up track frame on side which is to be removed.
※ After jack up the machine, set a block under the unit.

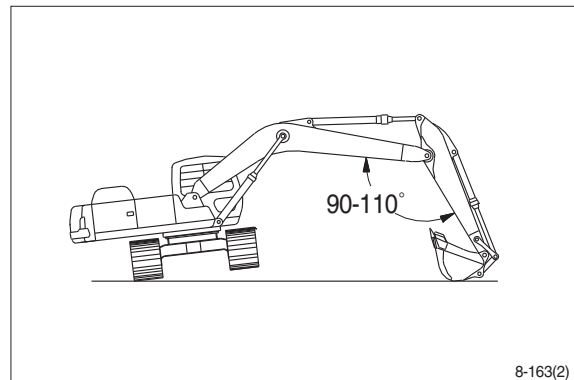

- (3) Remove the mounting bolt (1) and draw out the track roller (2).
 - Weight : 46 kg (106 lb)
 - Tightening torque : 57.9 ± 8.7 kgf·m
(419 ± 62.9 lbf · ft)

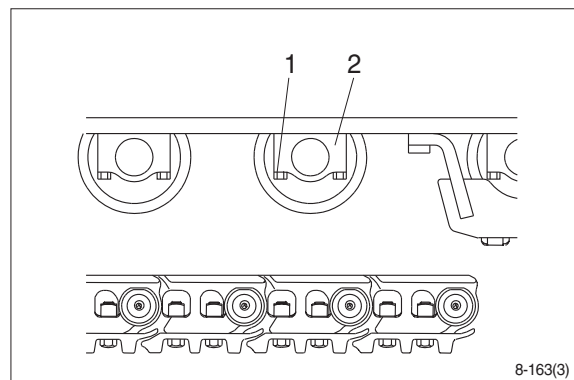

2) INSTALL

- (1) Carry out installation in the reverse order to removal.

4. IDLER AND RECOIL SPRING

1) REMOVAL

- (1) Remove the track link.
For detail, see removal of track link.

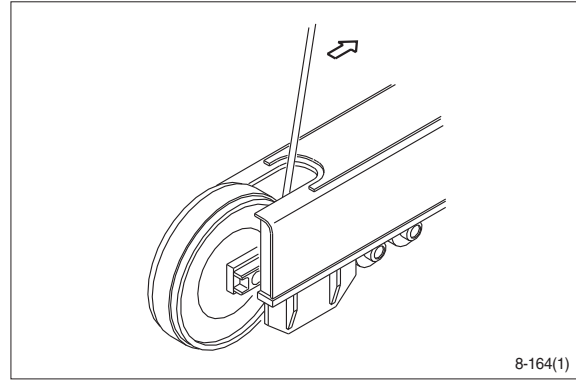

- (2) Sling the recoil spring (1) and pull out idler and recoil spring assembly from track frame, using a pry.
· Weight : 310 kg (680 lb)

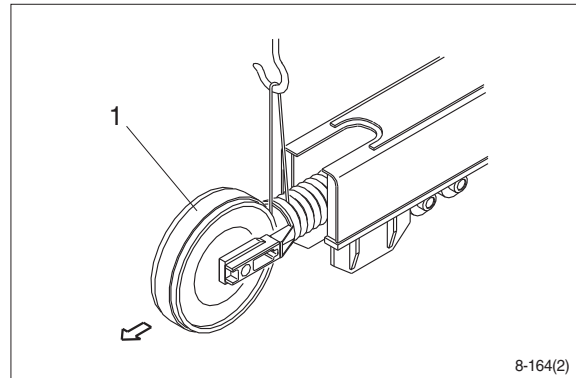

- (3) Remove the bolts (2), washers (3) and separate idler from recoil spring.
· Tightening torque : 29.7 ± 4.5 kgf·m
(215 ± 32.5 lbf · ft)

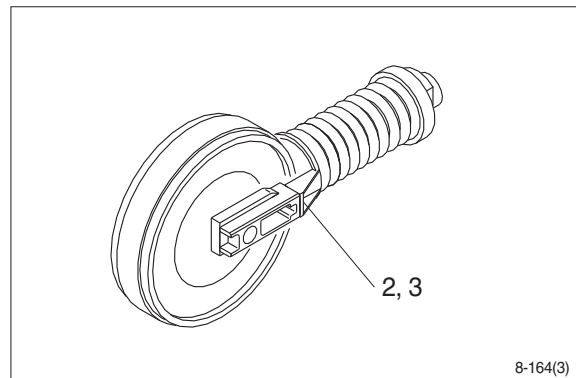

2) INSTALL

- (1) Carry out installation in the reverse order to removal.
※ Make sure that the boss on the end face of the recoil cylinder rod is in the hole of the track frame.

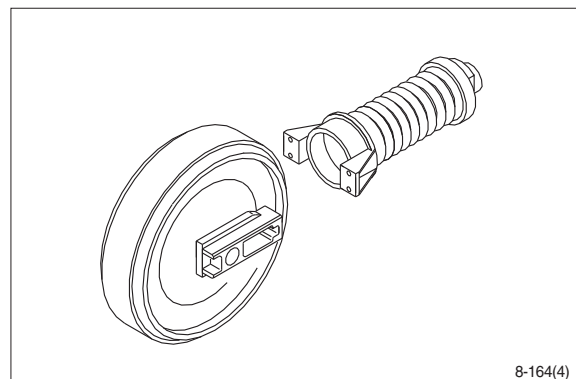

3) DISASSEMBLY AND ASSEMBLY OF IDLER

(1) Structure

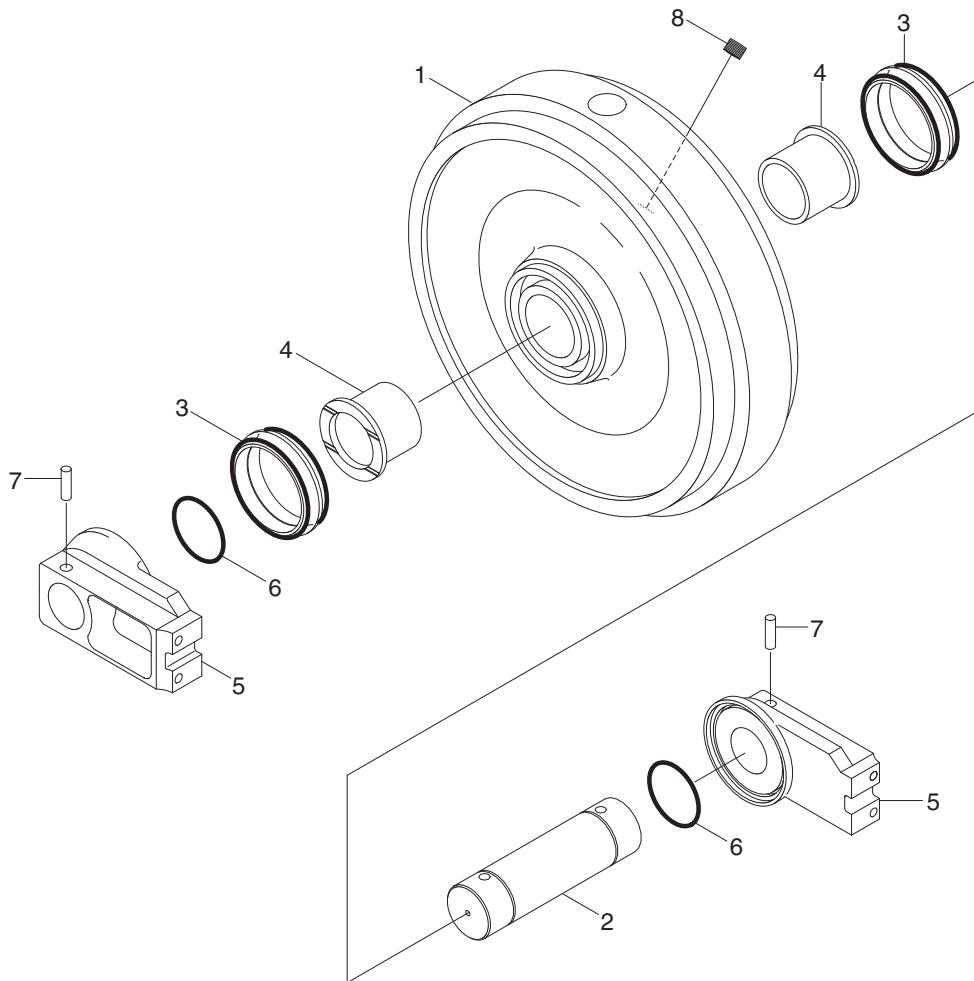

220S8DA43

- | | | | | | |
|---|---------------|---|---------|---|------------|
| 1 | Shell | 4 | Bushing | 7 | Spring pin |
| 2 | Shaft | 5 | Bracket | 8 | Plug |
| 3 | Seal assembly | 6 | O-ring | | |

(2) Disassembly

- ① Remove plug and drain oil.
- ② Draw out the spring pin (7), using a press.

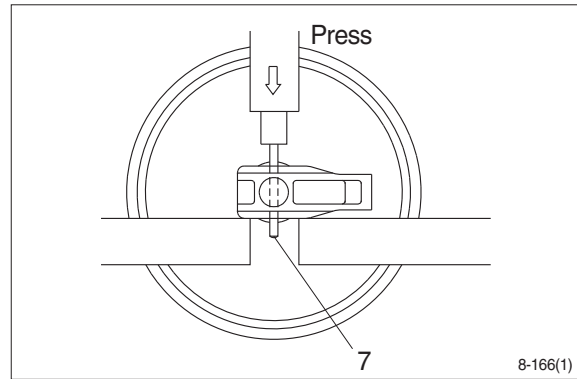

- ③ Pull out the shaft (2) with a press.
- ④ Remove seal (3) from idler (1) and bracket (5).
- ⑤ Remove O-ring (6) from shaft.

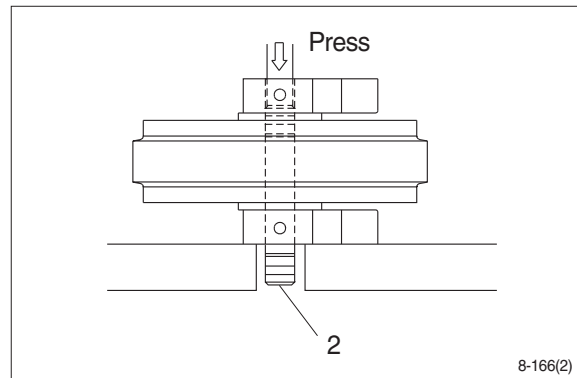

- ⑥ Remove the bushing (4) from idler, using a special tool.
Only remove bushing if replacement is necessary.

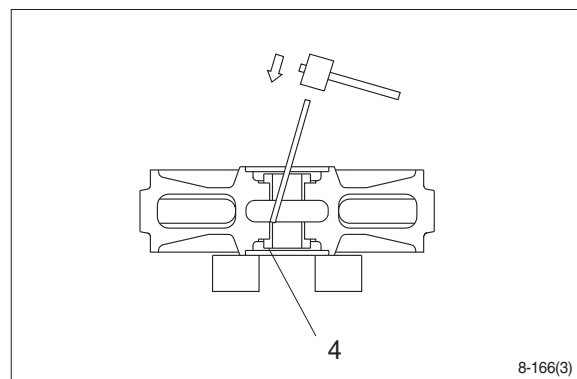

(3) Assembly

- ※ Before assembly, clean the parts.
- ※ Coat the sliding surfaces of all parts with oil.

- ① Cool up bushing (4) fully by some dry ice and press it into shell (1).

Do not press it at the normal temperature, or not knock in with a hammer even after the cooling.

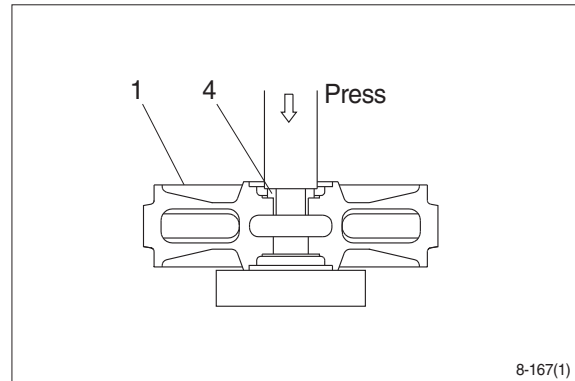

- ② Coat O-ring (6) with grease thinly, and install it to shaft (2).
- ③ Insert shaft (2) into bracket (5) and drive in the spring pin (7).

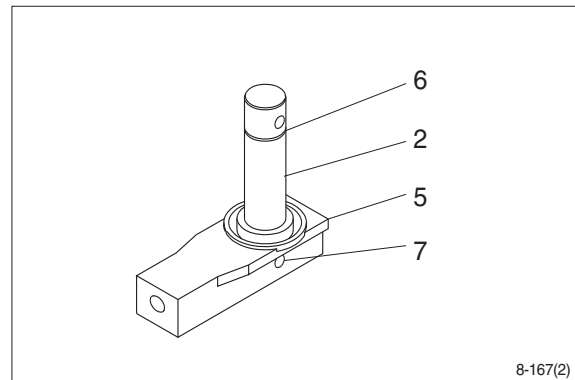

- ④ Install seal (3) to shell (1) and bracket (5).

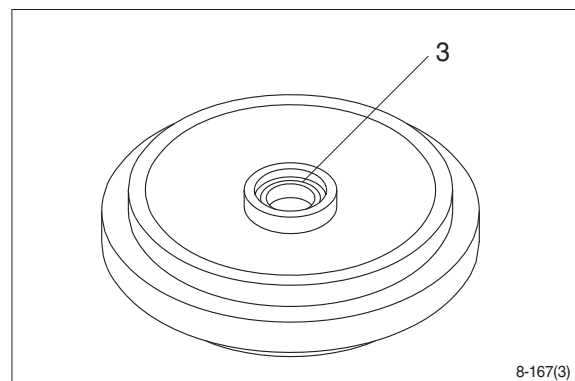

- ⑤ Install shaft (2) to shell (1).

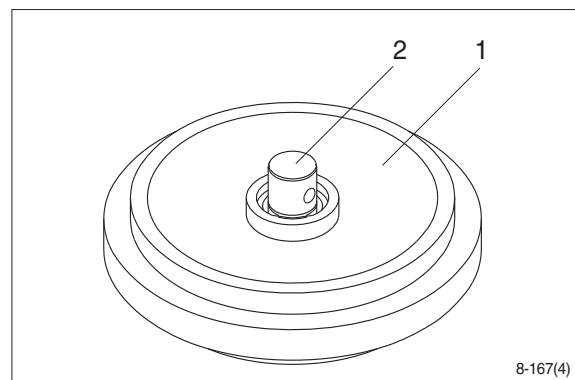

- ⑥ Install bracket (5) attached with seal (3).

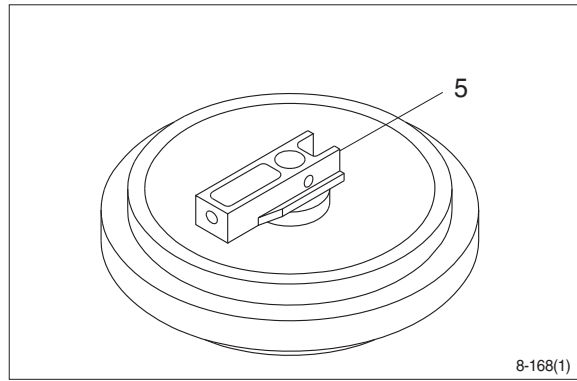

- ⑦ Knock in the spring pin (7) with a hammer.

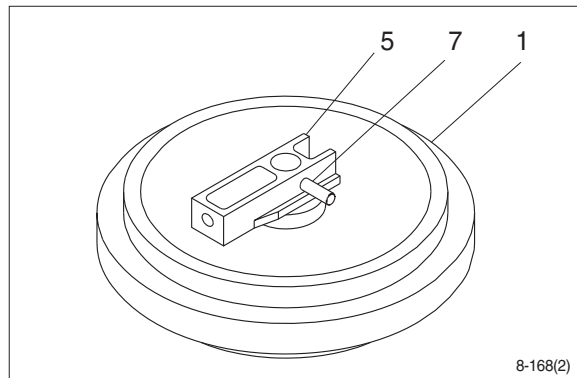

- ⑧ Lay bracket (5) on its side.
Supply engine oil to the specified level,
and tighten plug.

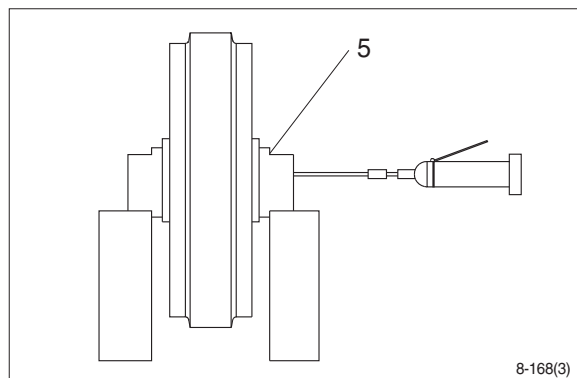

4) DISASSEMBLY AND ASSEMBLY OF RECOIL SPRING

(1) Structure (standard)

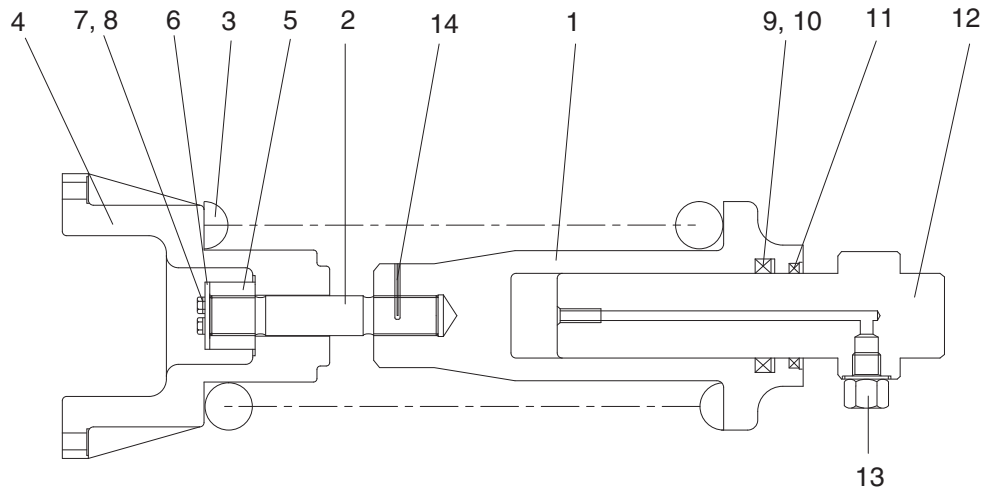

220L8UC100

- | | | | | | |
|---|----------|----|---------------|----|--------------|
| 1 | Body | 6 | Lock plate | 11 | Dust seal |
| 2 | Tie bar | 7 | Bolt | 12 | Rod |
| 3 | Spring | 8 | Spring washer | 13 | Grease valve |
| 4 | Bracket | 9 | Rod seal | 14 | Spring pin |
| 5 | Lock nut | 10 | Back up ring | | |

Structure (high walker)

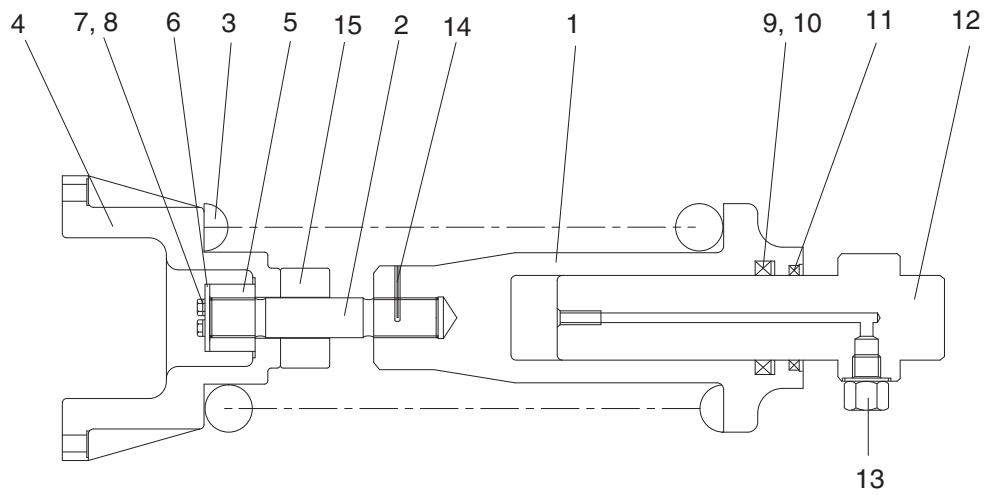

220L8UC101

- | | | | | | |
|---|----------|----|---------------|----|--------------|
| 1 | Body | 6 | Lock plate | 11 | Dust seal |
| 2 | Tie bar | 7 | Bolt | 12 | Rod |
| 3 | Spring | 8 | Spring washer | 13 | Grease valve |
| 4 | Bracket | 9 | Rod seal | 14 | Spring pin |
| 5 | Lock nut | 10 | Back up ring | 15 | Stopper |

(2) Disassembly

※ The illustrations are base on the standard.

① Apply pressure on spring (3) with a press.

※ The spring is under a large installed load. This is dangerous, so be sure to set properly.

② Remove bolt (7), spring washer (8) and lock plate (6).

③ Remove lock nut (5).

Take enough notice so that the press which pushes down the spring, should not be slipped out in its operation.

④ Lighten the press load slowly and remove bracket (4) and spring (3).

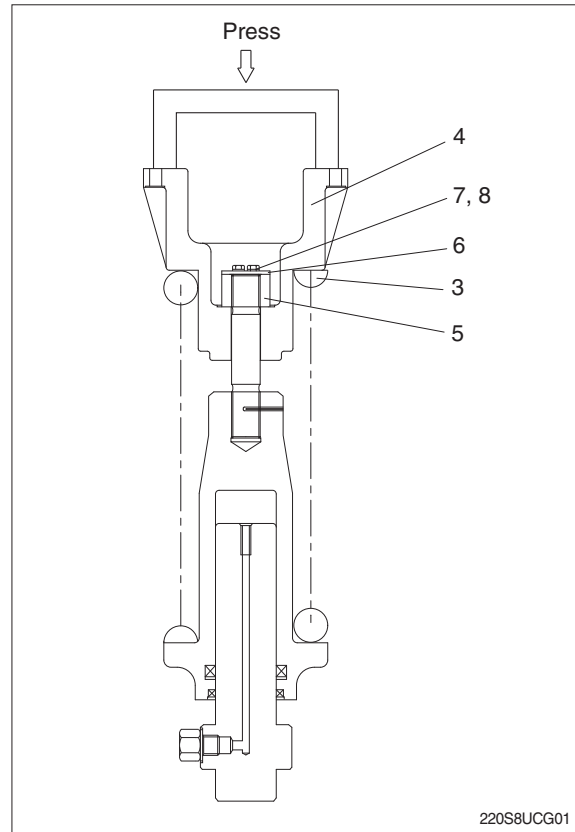

⑤ Remove rod (12) from body (1).

⑥ Remove grease valve (13) from rod (12).

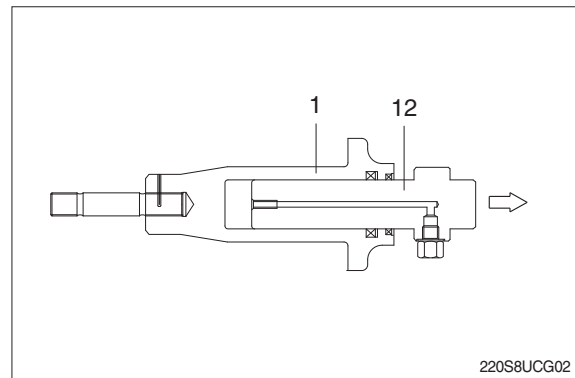

⑦ Remove rod seal (9), back up ring (10) and dust seal (11).

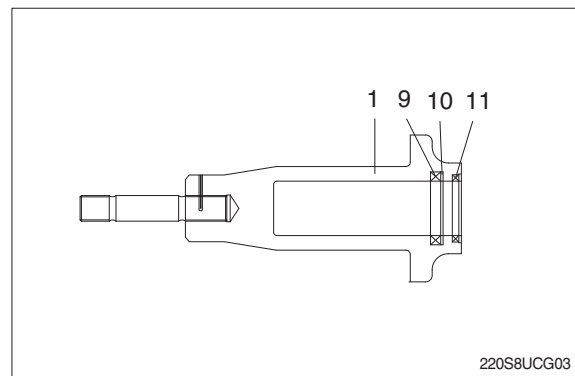

(3) Assembly

Install dust seal (11), back up ring (10) and rod seal (9) to body (1).

- ※ When installing dust seal (11) and rod seal (9), take full care so as not to damage the lip.

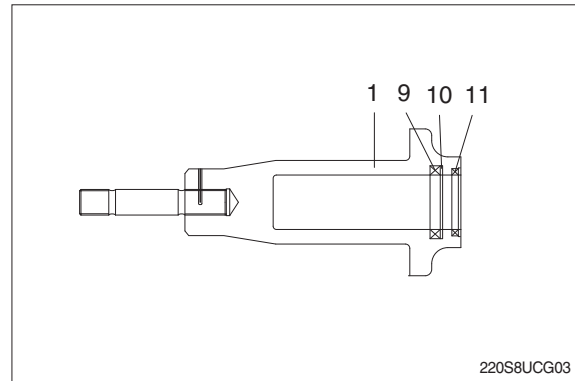

- ② Pour grease into body (1), then push in rod (12) by hand.
After take grease out of grease valve mounting hole, let air out.

- ※ If air letting is not sufficient, it may be difficult to adjust the tension of crawler.

- ③ Fit grease valve (13) to rod (12).

· Tightening torque

Standard : 13 ± 1.0 kgf·m (94 ± 7.2 lbf·ft)

Option : 13 ± 0.5 kgf·m (94 ± 3.6 lbf·ft)

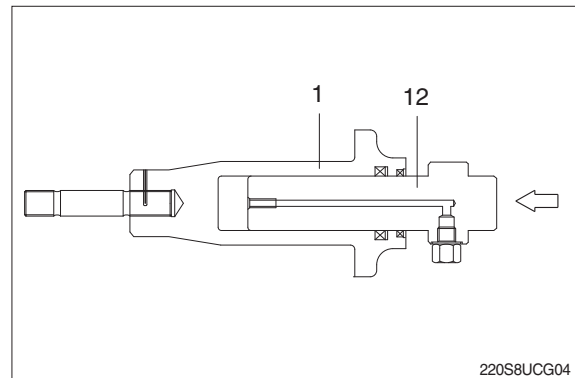

- ④ Install spring (3) and bracket (4) to body (1).

- ⑤ Apply pressure to spring (3) with a press and tighten lock nut (5).

· Spring set load

- Standard : 13716 kg (30239 lb)

- High walker : 16315 kg (35968 lb)

- ※ Apply sealant before assembling.

- ※ During the operation, pay attention specially to prevent the press from slipping out.

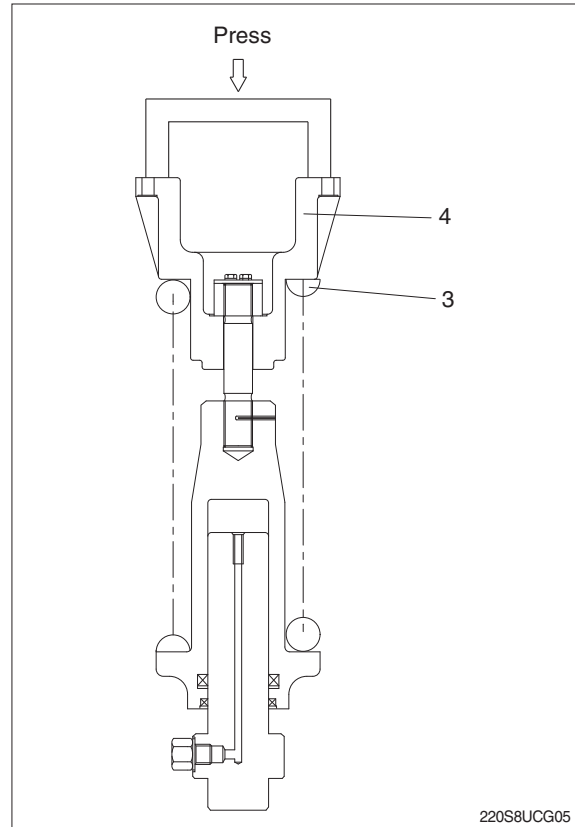

- ⑥ Lighten the press load and confirm the set length of spring (3).
- Standard : 431 ± 1.5 mm
 - High walker : 508 ± 1.5 mm
- ⑦ After the setting of spring (3), install lock plate (6), spring washer (8) and bolt (7).
- Tightening torque : 15 ± 0.5 kgf·m
(108 ± 3.6 lbf·ft)

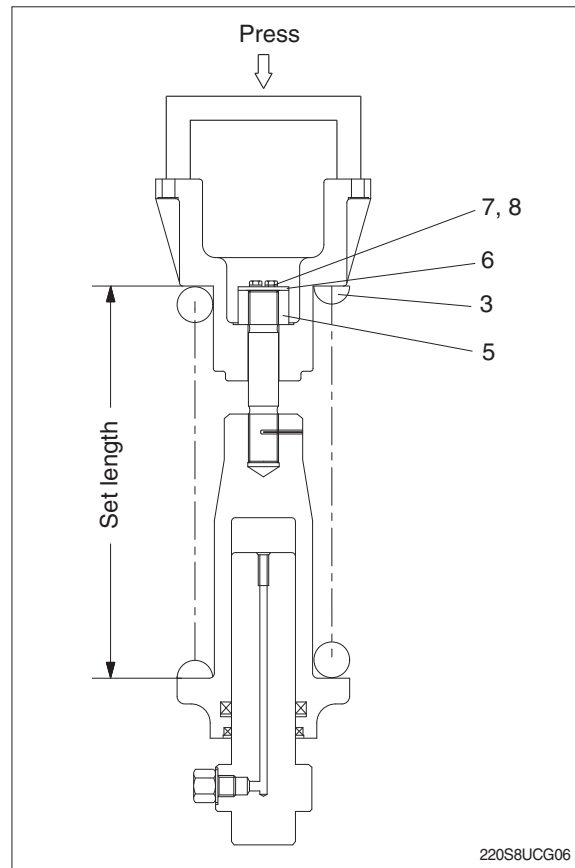

GROUP 11 WORK EQUIPMENT

1. STRUCTURE

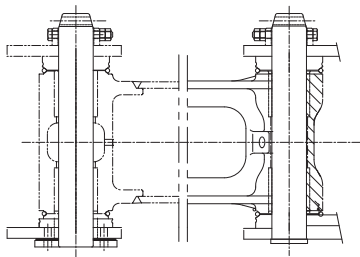
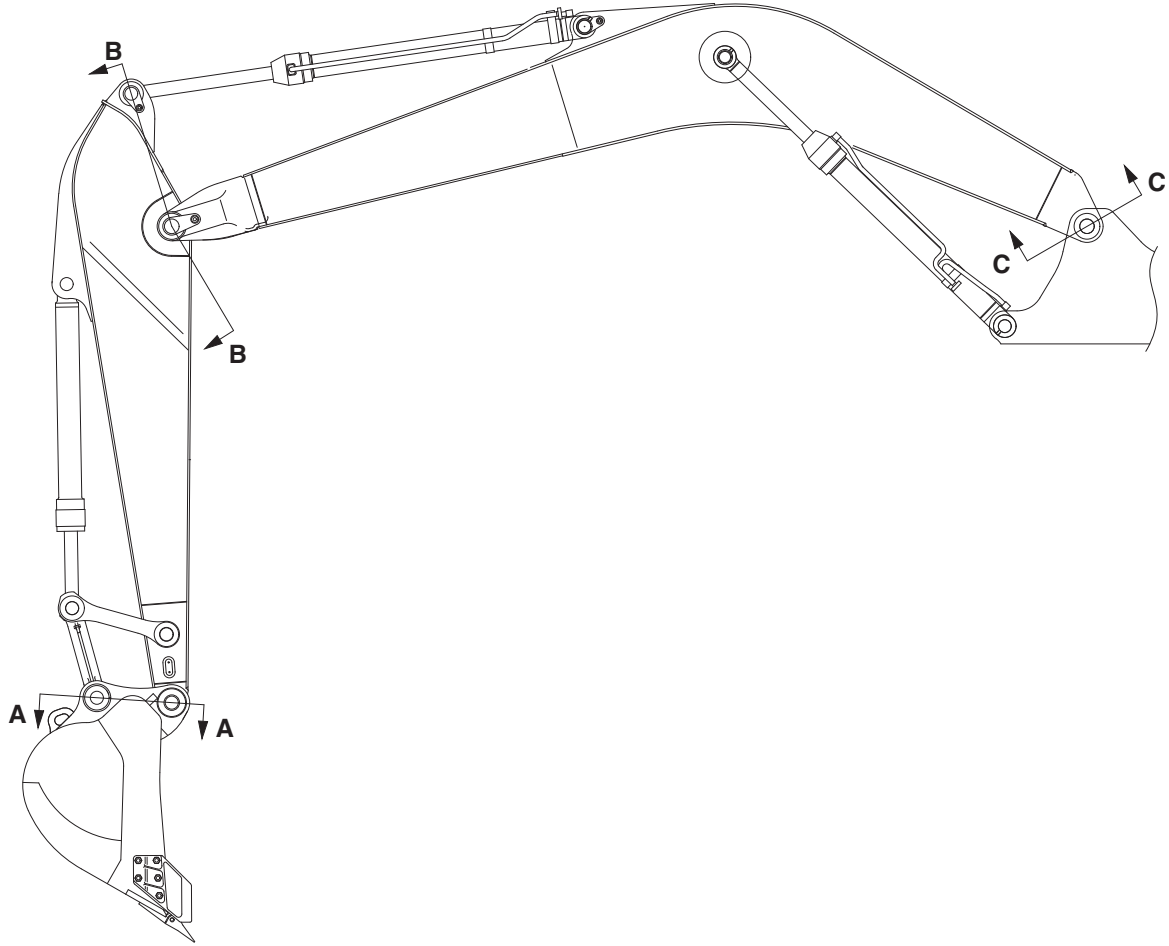

SECTION A

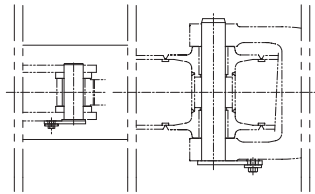

SECTION B

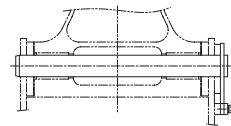

SECTION C

21078DA44

2. REMOVAL AND INSTALL

1) BUCKET ASSEMBLY

(1) Removal

- ① Lower the work equipment completely to ground with back of bucket facing down.

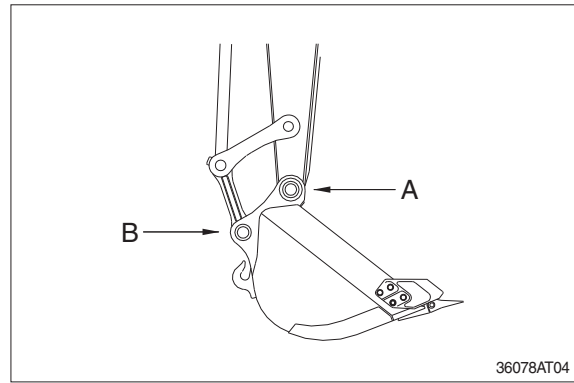

- ② Remove nut (1), bolt (2) and draw out the pin (A).
 - Tightening torque (1) : $29.7 \pm 45 \text{ kgf} \cdot \text{m}$
($215 \pm 32.5 \text{ lbf} \cdot \text{ft}$)

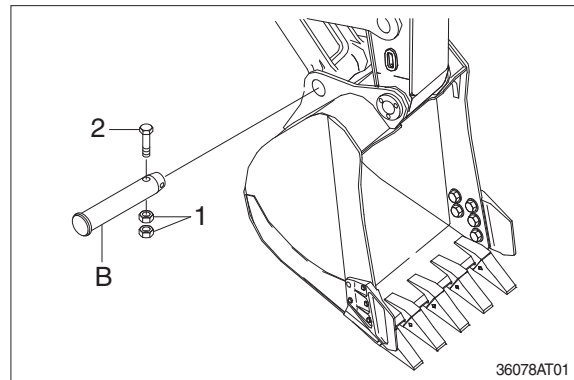

- ③ Remove nut (3), bolt (4) and draw out the pin (B).
- Tightening torque (3) : $29.7 \pm 45 \text{ kgf} \cdot \text{m}$
($215 \pm 32.5 \text{ lbf} \cdot \text{ft}$)

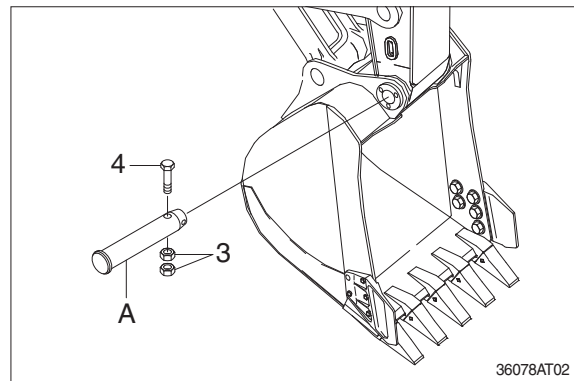

(2) Install

- ① Carry out installation in the reverse order to removal.
- ▲** When aligning the mounting position of the pin, do not insert your fingers in the pin hole.
- ※ Adjust the bucket clearance.
For detail, see operation manual.

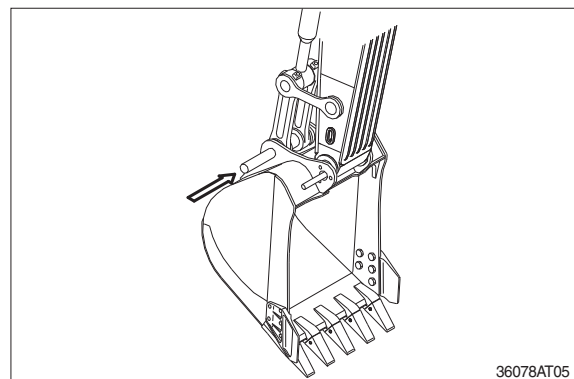

2) ARM ASSEMBLY

(1) Removal

※ Loosen the breather slowly to release the pressure inside the hydraulic tank.

▲ Escaping fluid under pressure can penetrate the skin causing serious injury.

① Remove bucket assembly.

For details, see removal of bucket assembly.

② Disconnect bucket cylinder hose (1).

▲ Fit blind plugs (5) in the piping at the chassis end securely to prevent oil from spurring out when the engine is started.

③ Sling arm cylinder assembly, remove spring, pin stopper and pull out pin.

※ Tie the rod with wire to prevent it from coming out.

④ For details, see removal of arm cylinder assembly.

Place a wooden block under the cylinder and bring the cylinder down to it.

⑤ Remove bolt (2), plate (3) and pull out the pin (4) then remove the arm assembly.

· Weight : 1095 kg (2410 lb)

· Tightening torque (2) : 29.7 ± 45 kgf·m
(215 ± 32.5 lbf·ft)

※ When lifting the arm assembly, always lift the center of gravity.

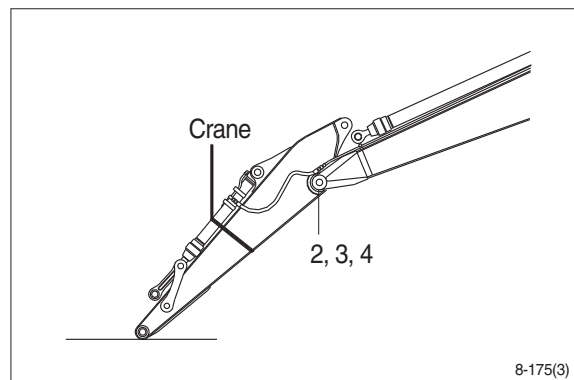
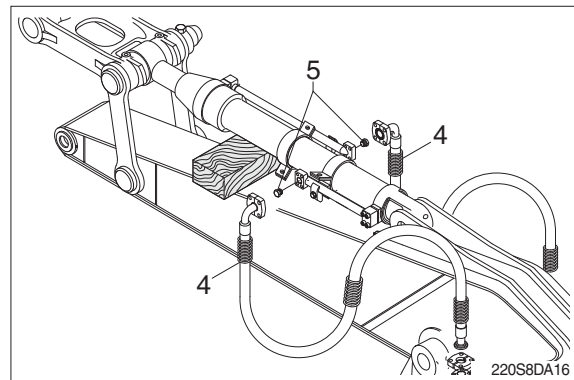
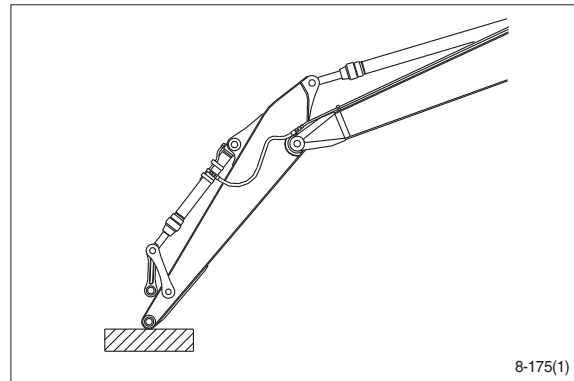

(2) Install

① Carry out installation in the reverse order to removal.

▲ When lifting the arm assembly, always lift the center of gravity.

※ Bleed the air from the cylinder.

3) BOOM ASSEMBLY

(1) Removal

- ① Remove arm and bucket assembly.
For details, see removal of arm and bucket assembly.
- ② Remove boom cylinder assembly from boom.
For details, see removal of boom cylinder assembly.

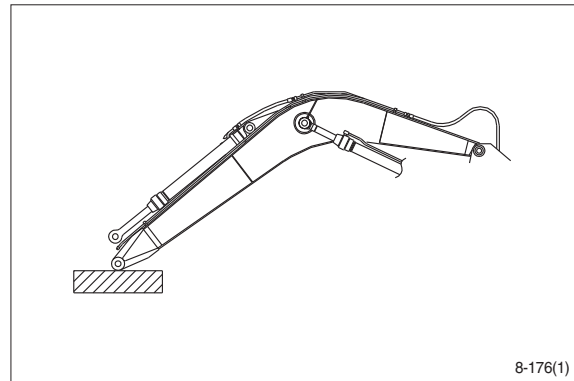

- ③ Disconnect head lamp wiring.
- ④ Disconnect bucket cylinder hose (2) and arm cylinder hose (1).
- ※ When the hose are disconnected, oil may spurt out.
- ⑤ Sling boom assembly (3).

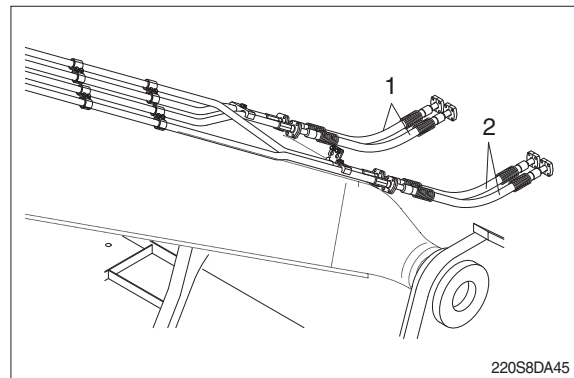

- ⑥ Remove bolt (4), plate (5) and pull out the pin (6) then remove boom assembly.
 - Weight :1950 kg (4300 lb)
 - Tightening torque (4) : 29.7 ± 45 kgf·m
(215 ± 32.5 lbf·ft)
- ※ When lifting the boom assembly always lift the center of gravity.

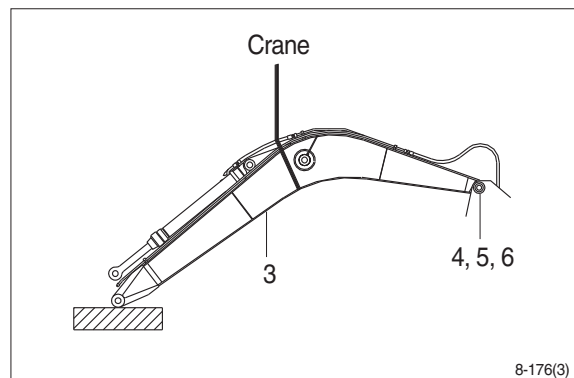

(2) Install

- ① Carry out installation in the reverse order to removal.
- ▲ When lifting the arm assembly, always lift the center of gravity.
- ※ Bleed the air from the cylinder.

