

SECTION 1 GENERAL



Group 1 Safety Hints	1-1
Group 2 Specifications	1-10

SECTION 1 GENERAL

GROUP 1 SAFETY

FOLLOW SAFE PROCEDURE

Unsafe work practices are dangerous. Understand service procedure before doing work; Do not attempt shortcuts.

WEAR PROTECTIVE CLOTHING

Wear close fitting clothing and safety equipment appropriate to the job.



WARN OTHERS OF SERVICE WORK

Unexpected machine movement can cause serious injury.

Before performing any work on the excavator, attach a 「Do Not Operate」 tag on the right side control lever.

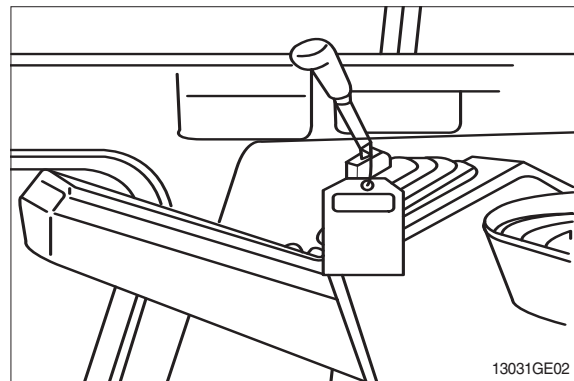

USE HANDHOLDS AND STEPS

Falling is one of the major causes of personal injury.

When you get on and off the machine, always maintain a three point contact with the steps and handrails and face the machine. Do not use any controls as handholds.

Never jump on or off the machine. Never mount or dismount a moving machine.

Be careful of slippery conditions on platforms, steps, and handrails when leaving the machine.

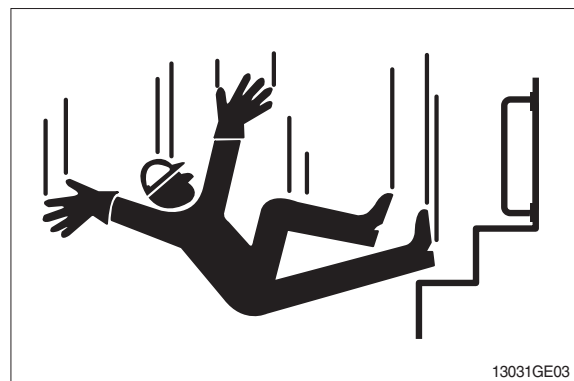

PREPARE FOR EMERGENCIES

Be prepared if a fire starts.

Keep a first aid kit and fire extinguisher handy.

Keep emergency numbers for doctors, ambulance service, hospital, and fire department near your telephone.

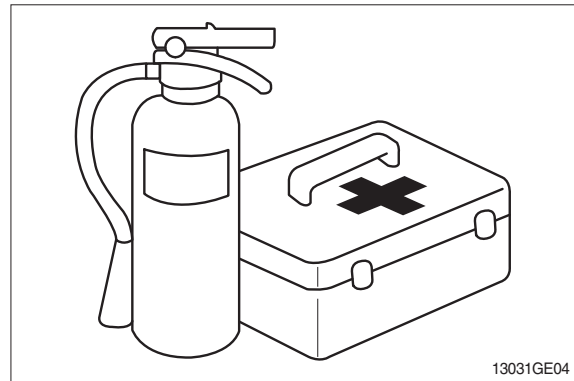

PROTECT AGAINST FLYING DEBRIS

Guard against injury from flying pieces of metal or debris; Wear goggles or safety glasses.

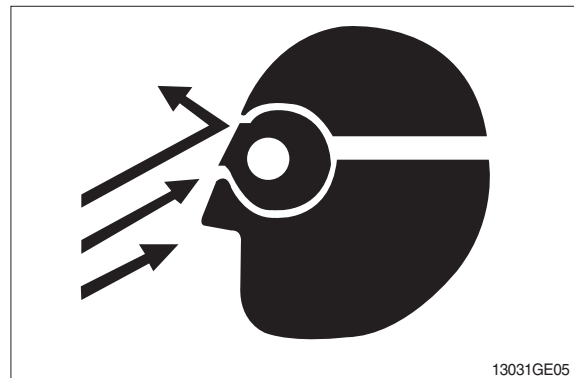

PROTECT AGAINST NOISE

Prolonged exposure to loud noise can cause impairment or loss of hearing.

Wear a suitable hearing protective device such as earmuffs or earplugs to protect against objectionable or uncomfortable loud noises.



AVOID POWER LINES

Serious injury or death can result from contact with electric lines.

Never move any part of the machine or load closer to electric line than 3m(10ft) plus twice the line insulator length.

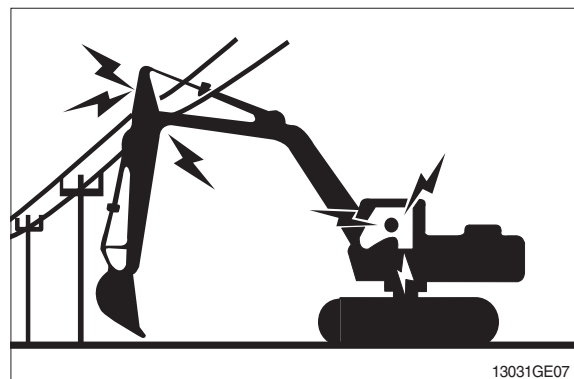

KEEP RIDERS OFF EXCAVATOR

Only allow the operator on the excavator. Keep riders off.

Riders on excavator are subject to injury such as being struck by foreign objects and being thrown off the excavator. Riders also obstruct the operator's view resulting in the excavator being operated in an unsafe manner.

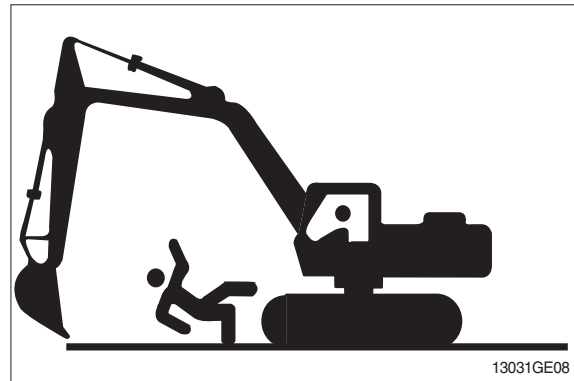

MOVE AND OPERATE MACHINE SAFELY

Bystanders can be run over. Know the location of bystanders before moving, swinging, or operating the machine.

Always keep the travel alarm in working condition. It warns people when the excavator starts to move.

Use a signal person when moving, swinging, or operating the machine in congested areas. Coordinate hand signals before starting the excavator.

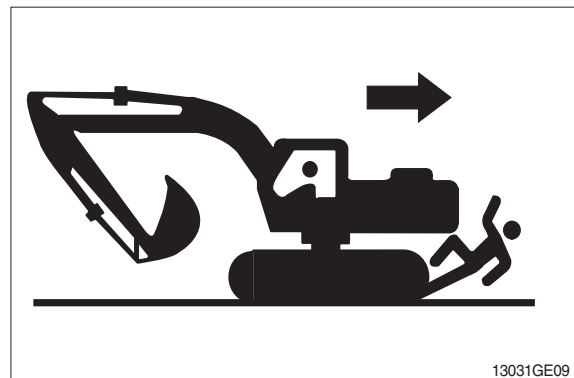

OPERATE ONLY FROM OPERATOR'S SEAT

Avoid possible injury machine damage. Do not start engine by shorting across starter terminals.

NEVER start engine while standing on ground. Start engine only from operator's seat.



PARK MACHINE SAFELY

Before working on the machine:

- Park machine on a level surface.
- Lower bucket to the ground.
- Turn auto idle switch off.
- Run engine at 1/2 speed without load for 2 minutes.
- Turn key switch to OFF to stop engine. Remove key from switch.
- Move pilot control shutoff lever to locked position.
- Allow engine to cool.

SUPPORT MACHINE PROPERLY

Always lower the attachment or implement to the ground before you work on the machine. If you must work on a lifted machine or attachment, securely support the machine or attachment.

Do not support the machine on cinder blocks, hollow tiles, or props that may crumble under continuous load.

Do not work under a machine that is supported solely by a jack. Follow recommended procedures in this manual.

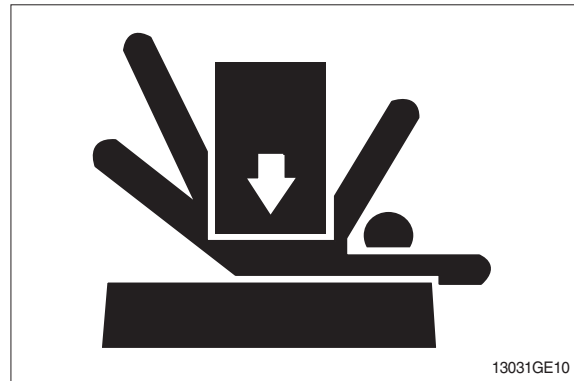

SERVICE COOLING SYSTEM SAFELY

Explosive release of fluids from pressurized cooling system can cause serious burns.

Shut off engine. Only remove filler cap when cool enough to touch with bare hands.



HANDLE FLUIDS SAFELY-AVOID FIRES

Handle fuel with care; It is highly flammable. Do not refuel the machine while smoking or when near open flame or sparks. Always stop engine before refueling machine. Fill fuel tank outdoors.



Store flammable fluids away from fire hazards. Do not incinerate or puncture pressurized containers.

Make sure machine is clean of trash, grease, and debris.

Do not store oily rags; They can ignite and burn spontaneously.



BEWARE OF EXHAUST FUMES

Prevent asphyxiation. Engine exhaust fumes can cause sickness or death.

If you must operate in a building, be positive there is adequate ventilation. Either use an exhaust pipe extension to remove the exhaust fumes or open doors and windows to bring enough outside air into the area.

REMOVE PAINT BEFORE WELDING OR HEATING

Avoid potentially toxic fumes and dust.

Hazardous fumes can be generated when paint is heated by welding, soldering, or using a torch.

Do all work outside or in a well ventilated area. Dispose of paint and solvent properly.

Remove paint before welding or heating:

- If you sand or grind paint, avoid breathing the dust.
Wear an approved respirator.
- If you use solvent or paint stripper, remove stripper with soap and water before welding. Remove solvent or paint stripper containers and other flammable material from area. Allow fumes to disperse at least 15 minutes before welding or heating.

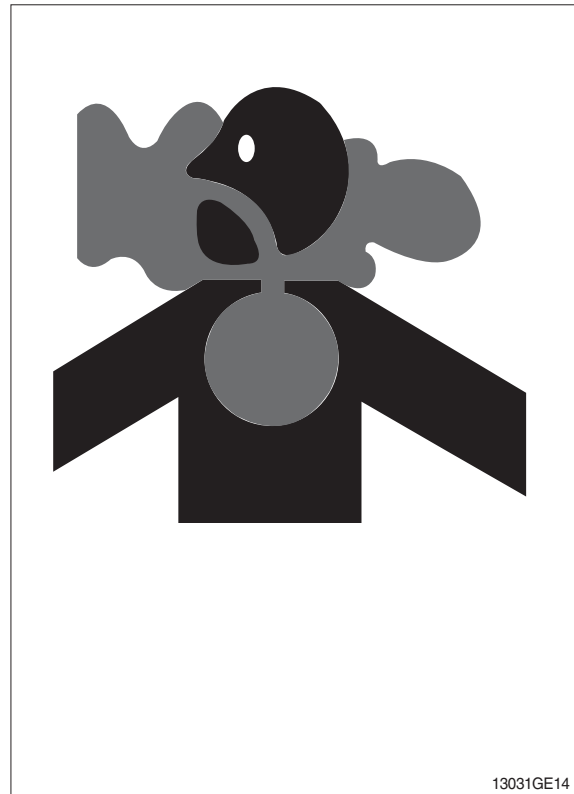

ILLUMINATE WORK AREA SAFELY

Illuminate your work area adequately but safely. Use a portable safety light for working inside or under the machine. Make sure the bulb is enclosed by a wire cage. The hot filament of an accidentally broken bulb can ignite spilled fuel or oil.



SERVICE MACHINE SAFELY

Tie long hair behind your head. Do not wear a necktie, scarf, loose clothing or necklace when you work near machine tools or moving parts. If these items were to get caught, severe injury could result.

Remove rings and other jewelry to prevent electrical shorts and entanglement in moving parts.

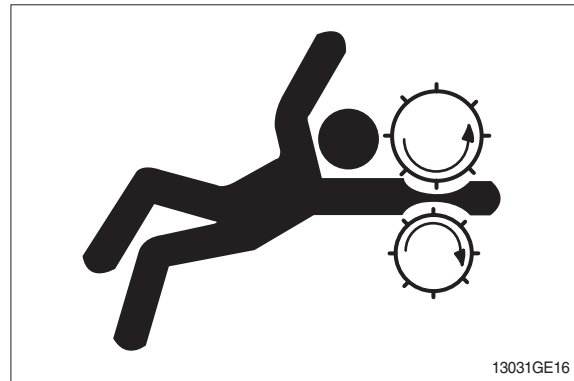

STAY CLEAR OF MOVING PARTS

Entanglements in moving parts can cause serious injury.

To prevent accidents, use care when working around rotating parts.

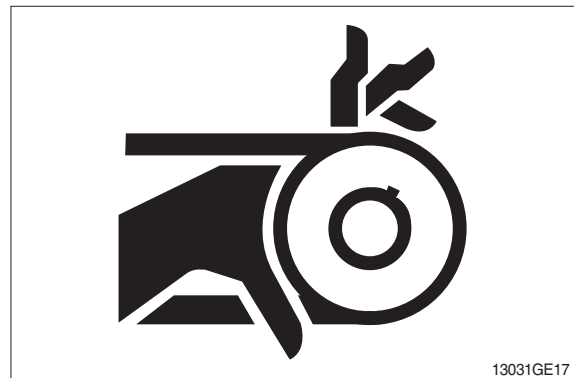

AVOID HIGH PRESSURE FLUIDS

Escaping fluid under pressure can penetrate the skin causing serious injury.

Avoid the hazard by relieving pressure before disconnecting hydraulic or other lines. Tighten all connections before applying pressure.

Search for leaks with a piece of cardboard. Protect hands and body from high pressure fluids.

If an accident occurs, see a doctor immediately. Any fluid injected into the skin must be surgically removed within a few hours or gangrene may result.

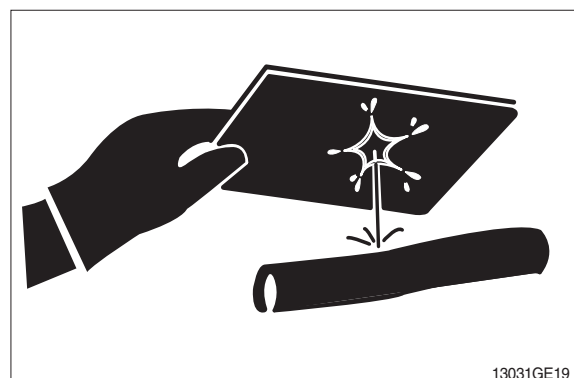

AVOID HEATING NEAR PRESSURIZED FLUID LINES

Flammable spray can be generated by heating near pressurized fluid lines, resulting in severe burns to yourself and bystanders. Do not heat by welding, soldering, or using a torch near pressurized fluid lines or other flammable materials.

Pressurized lines can be accidentally cut when heat goes beyond the immediate flame area. Install fire resisting guards to protect hoses or other materials.



PREVENT BATTERY EXPLOSIONS

Keep sparks, lighted matches, and flame away from the top of battery. Battery gas can explode.

Never check battery charge by placing a metal object across the posts. Use a volt-meter or hydrometer.

Do not charge a frozen battery; It may explode. Warm battery to 16 °C (60 °F).



PREVENT ACID BURNS

Sulfuric acid in battery electrolyte is poisonous. It is strong enough to burn skin, eat holes in clothing, and cause blindness if splashed into eyes.

Avoid the hazard by:

1. Filling batteries in a well-ventilated area.
2. Wearing eye protection and rubber gloves.
3. Avoiding breathing fumes when electrolyte is added.
4. Avoiding spilling or dripping electrolyte.
5. Use proper jump start procedure.

If you spill acid on yourself:

1. Flush your skin with water.
2. Apply baking soda or lime to help neutralize the acid.
3. Flush your eyes with water for 10-15 minutes. Get medical attention immediately.

If acid is swallowed:

1. Drink large amounts of water or milk.
2. Then drink milk of magnesia, beaten eggs, or vegetable oil.
3. Get medical attention immediately.

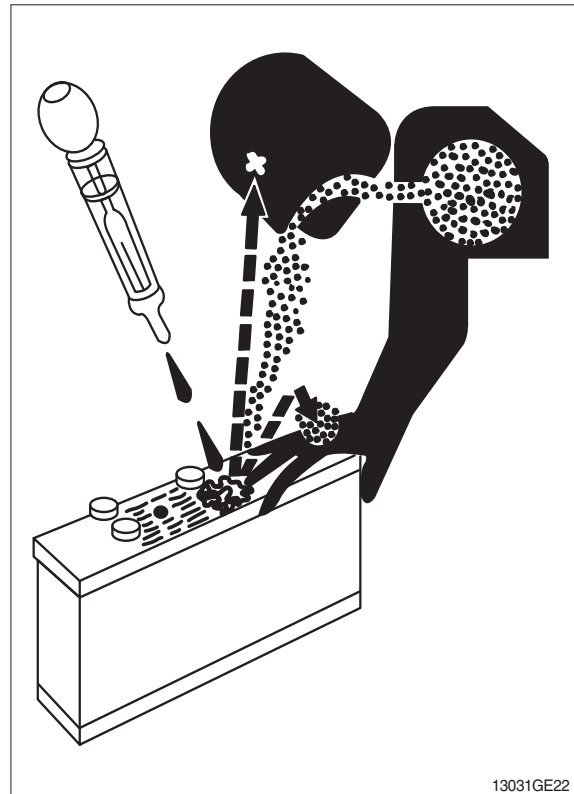

USE TOOLS PROPERLY

Use tools appropriate to the work. Makeshift tools, parts, and procedures can create safety hazards.

Use power tools only to loosen threaded tools and fasteners.

For loosening and tightening hardware, use the correct size tools. **DO NOT** use U.S. measurement tools on metric fasteners. Avoid bodily injury caused by slipping wrenches.

Use only recommended replacement parts. (See Parts catalogue.)

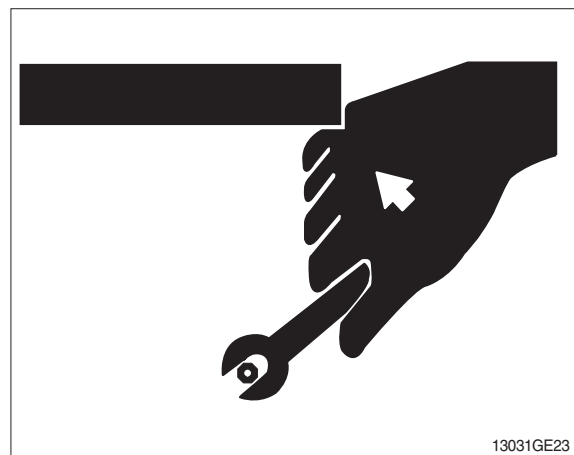

DISPOSE OF FLUIDS PROPERLY

Improperly disposing of fluids can harm the environment and ecology. Before draining any fluids, find out the proper way to dispose of waste from your local environmental agency.

Use proper containers when draining fluids. Do not use food or beverage containers that may mislead someone into drinking from them.

DO NOT pour oil into the ground, down a drain, or into a stream, pond, or lake. Observe relevant environmental protection regulations when disposing of oil, fuel, coolant, brake fluid, filters, batteries, and other harmful waste.

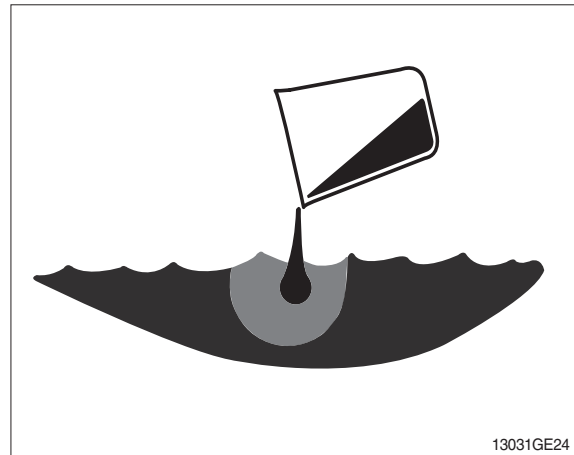

REPLACE SAFETY SIGNS

Replace missing or damaged safety signs. See the machine operator's manual for correct safety sign placement.

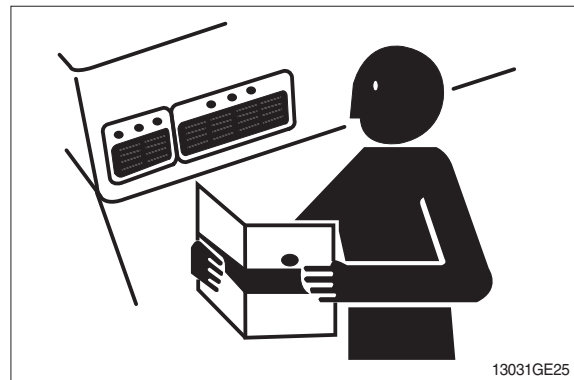

LIVE WITH SAFETY

Before returning machine to customer, make sure machine is functioning properly, especially the safety systems. Install all guards and shields.

GROUP 2 SPECIFICATIONS

1. MAJOR COMPONENT

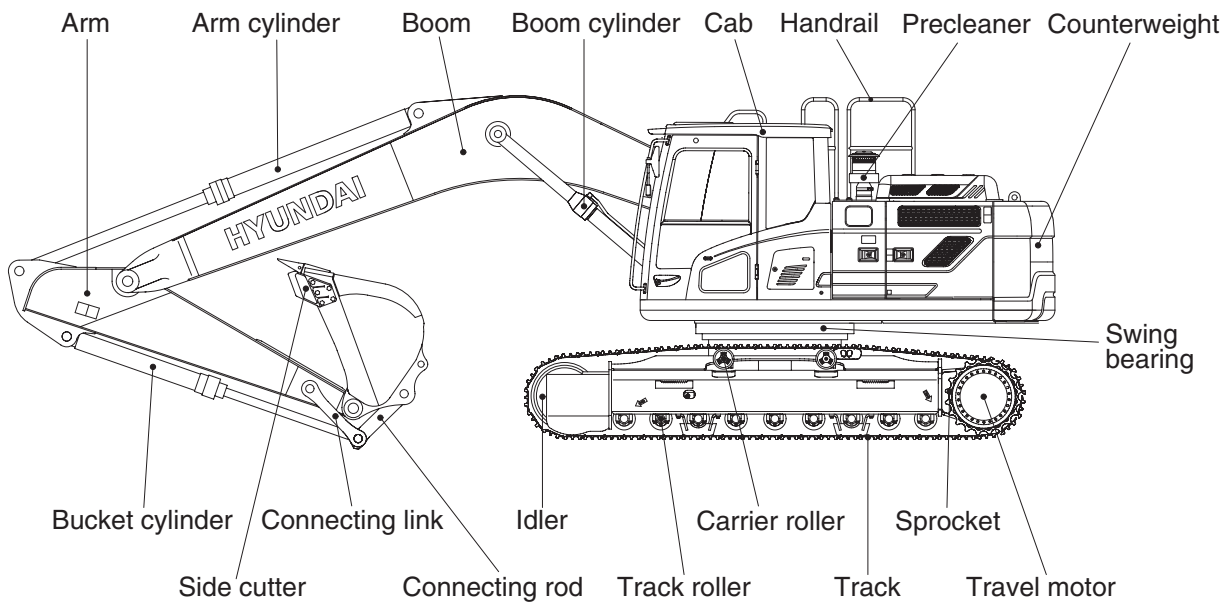
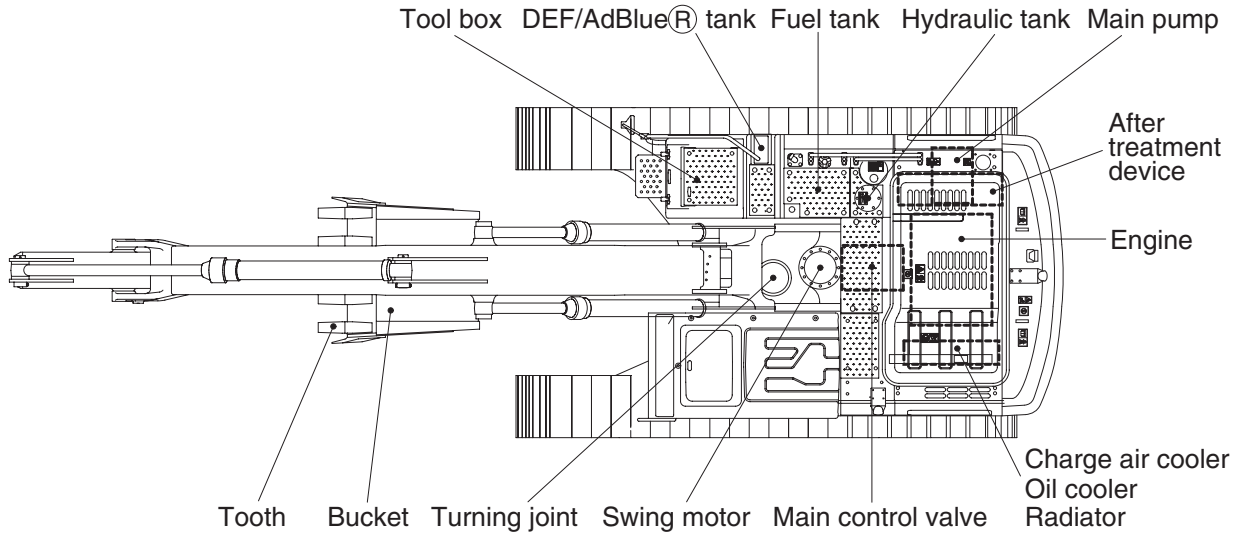

220F2SP01

2. SPECIFICATIONS

1) HX220 L

(1) 5.68 m (18' 8") boom and 2.92 m (9' 7") arm

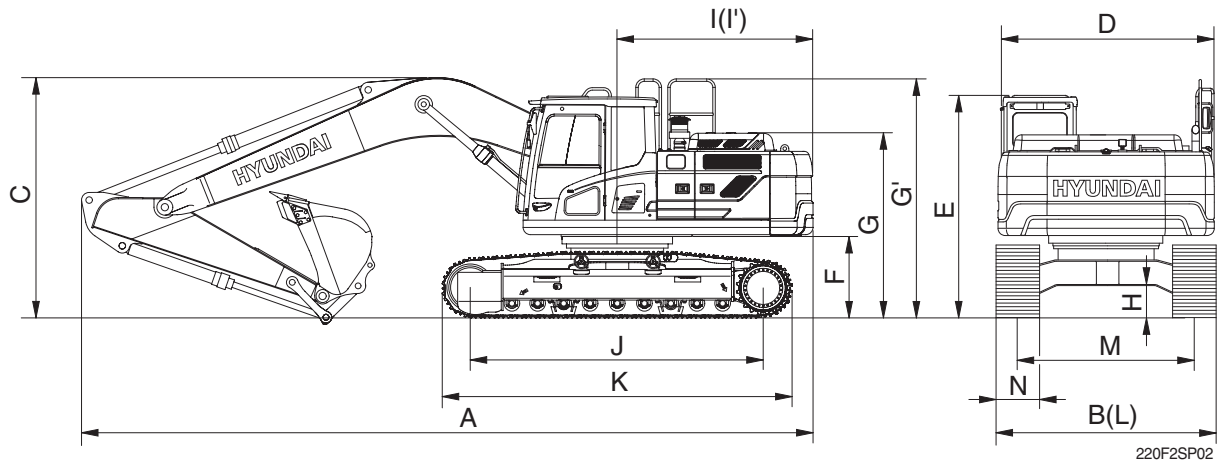

Description	Unit	Specification
Operating weight	kg (lb)	22100 (48720)
Bucket capacity (SAE heaped), standard	m ³ (yd ³)	0.92 (1.20)
Overall length	A	9530 (31' 3")
Overall width, with 600mm shoe	B	2990 (9' 10")
Overall height of boom	C	3030 (9' 11")
Superstructure width	D	2740 (9' 0")
Overall height of cab	E	3000 (9' 8")
Ground clearance of counterweight	F	1060 (3' 6")
Engine cover height	G	2470 (8' 1")
Overall height of guardrail	G'	3210 (10' 5")
Minimum ground clearance	H	480 (1' 7")
Rear-end distance	I	2770 (9' 1")
Rear-end swing radius	I'	2890 (9' 5")
Distance between tumblers	J	3650 (12' 0")
Undercarriage length	K	4404 (14' 4")
Undercarriage width	L	2990 (9' 10")
Track gauge	M	2390 (7' 10")
Track shoe width, standard	N	600 (24")
Travel speed (low/high)	km/hr (mph)	3.8/5.8 (2.36/3.60)
Swing speed	rpm	12.5
Gradeability	Degree (%)	35 (70)
Ground pressure (600 mm shoe)	kgf/cm ² (psi)	0.47 (6.68)
Max traction force	kg (lb)	20200 (44530)

(2) 5.65 m (18' 5") 2-piece boom and 2.92 m (9' 7") arm

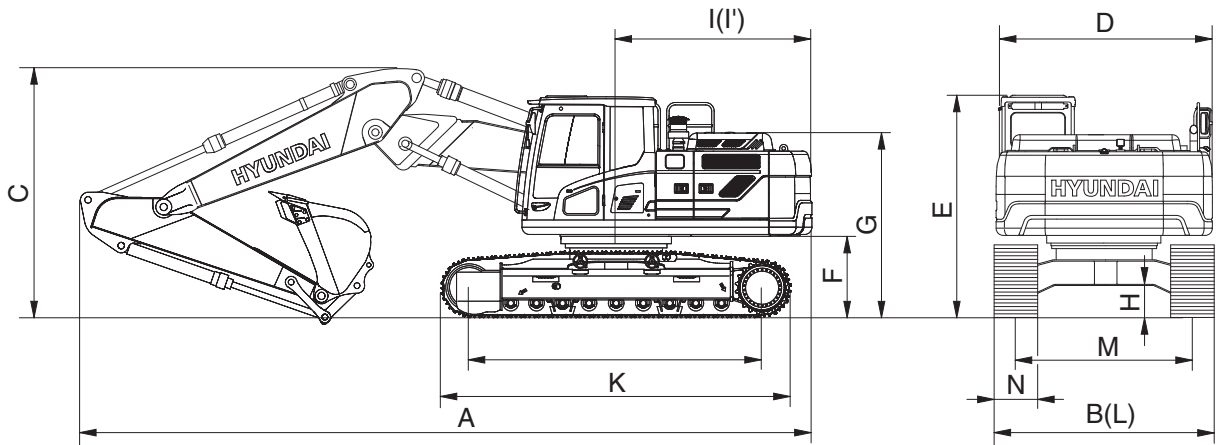

220F2SP52

Description		Unit	Specification
Operating weight		kg (lb)	23440 (51680)
Bucket capacity (SAE heaped), standard		m ³ (yd ³)	0.92 (1.20)
Overall length	A	mm (ft-in)	9530 (31' 3")
Overall width, with 600 mm shoe	B		2990 (9' 10")
Overall height	C		3030 (9' 11")
Superstructure width	D		2740 (9' 0")
Overall height of cab	E		3200 (10' 5")
Ground clearance of counterweight	F		1060 (3' 6")
Engine cover height	G		2470 (8' 1")
Overall height of guardrail	G'		3210 (10' 5")
Minimum ground clearance	H		480 (1' 7")
Rear-end distance	I		2770 (9' 1")
Rear-end swing radius	I'		2890 (9' 5")
Distance between tumbler	J		3650 (12' 0")
Undercarriage length	K		4404 (14' 4")
Undercarriage width	L		2990 (9' 10")
Track gauge	M		2390 (7' 10")
Track shoe width, standard	N	600 (24")	
Travel speed (low/high)		km/hr (mph)	3.8/5.8 (2.36/3.60)
Swing speed		rpm	12.5
Gradeability		Degree (%)	35 (70)
Ground pressure (600 mm shoe)		kgf/cm ² (psi)	0.50 (7.11)
Max traction force		kg (lb)	20200 (44530)

2) HX220 L LONG REACH

(1) 8.2 m (26' 11") boom and 6.3 m (20' 8") arm

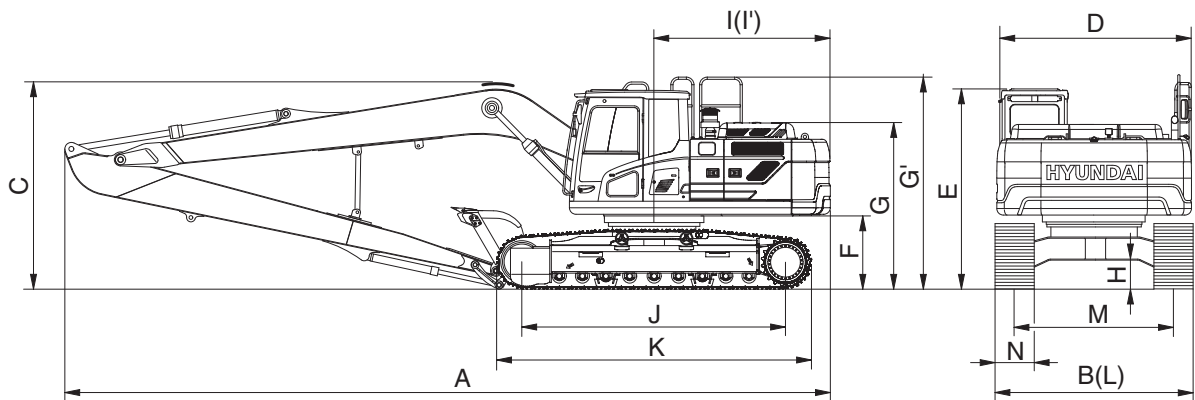

220F2SP03

Description	Unit	Specification
Operating weight	kg (lb)	24820 (54720)
Bucket capacity (SAE heaped), standard	m ³ (yd ³)	0.52 (0.68)
Overall length	A	12030 (39' 6")
Overall width, with 800 mm shoe	B	3190 (10' 6")
Overall height	C	3280 (10' 9")
Superstructure width	D	2740 (9' 0")
Overall height of cab	E	3000 (9' 8")
Ground clearance of counterweight	F	1060 (3' 6")
Engine cover height	G	2470 (8' 1")
Overall height of guardrail	G'	3210 (10' 5")
Minimum ground clearance	H	480 (1' 7")
Rear-end distance	I	2770 (9' 1")
Rear-end swing radius	I'	2890 (9' 5")
Distance between tumblers	J	3650 (12' 0")
Undercarriage length	K	4404 (14' 4")
Undercarriage width	L	3190 (10' 6")
Track gauge	M	2390 (7' 10")
Track shoe width	N	800 (32")
Travel speed (low/high)	km/hr (mph)	3.8/5.8 (2.36/3.60)
Swing speed	rpm	12.5
Gradeability	Degree (%)	35 (70)
Ground pressure (800 mm shoe)	kgf/cm ² (psi)	0.39 (5.55)
Max traction force	kg (lb)	20200 (44530)

3) HX220 L HIGH WALKER

(1) 5.68 m (18' 8") boom and 2.92 m (9' 7") arm

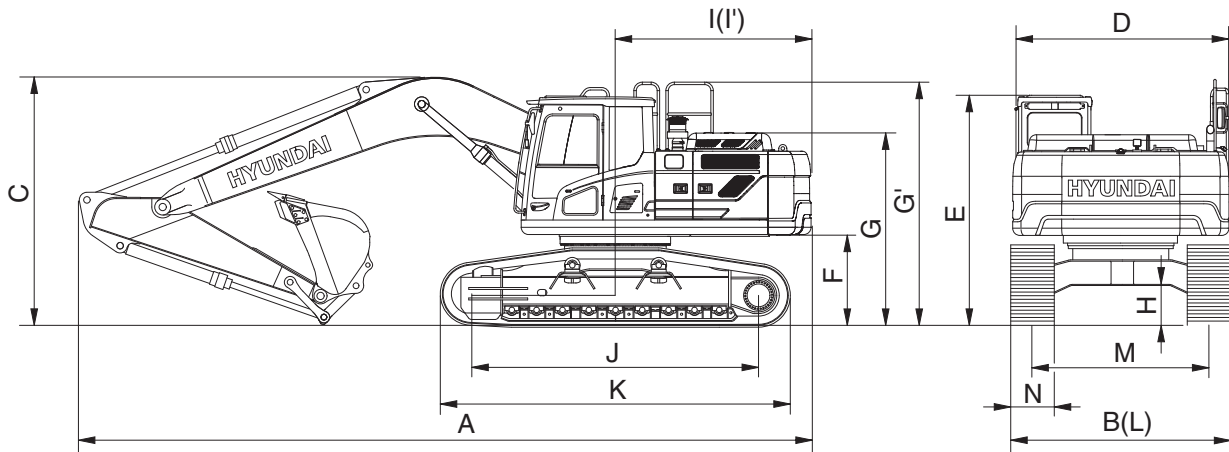

220F2SP04

Description		Unit	Specification
Operating weight		kg (lb)	23560 (51940)
Bucket capacity (SAE heaped), standard		m ³ (yd ³)	0.92 (1.20)
Overall length	A	mm (ft-in)	9470 (31' 1")
Overall width, with 600 mm shoe	B		3395 (11' 2")
Overall height	C		3060 (10' 0")
Superstructure width	D		2740 (9' 0")
Overall height of cab	E		3200 (10' 5")
Ground clearance of counterweight	F		1260 (4' 1")
Engine cover height	G		2670 (8' 8")
Overall height of guardrail	G'		3410 (11' 2")
Minimum ground clearance	H		660 (2' 2")
Rear-end distance	I		2770 (9' 1")
Rear-end swing radius	I'		2890 (9' 5")
Distance between tumblers	J		3650 (12' 0")
Undercarriage length	K		4404 (14' 4")
Undercarriage width	L		3395 (11' 2")
Track gauge	M		2795 (9' 2")
Track shoe width, standard	N		600 (24")
Travel speed (low/high)		km/hr (mph)	3.8/5.8 (2.36/3.60)
Swing speed		rpm	12.5
Gradeability		Degree (%)	35 (70)
Ground pressure (600 mm shoe)		kgf/cm ² (psi)	0.50 (7.11)
Max traction force		kg (lb)	20200 (44530)

3. WORKING RANGE

1) HX220 L

(1) 5.68 m (18' 8") boom

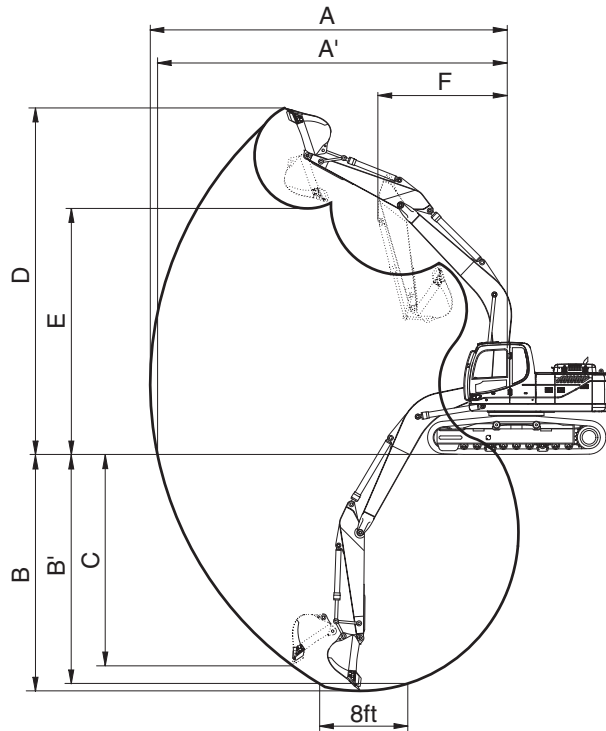

21092SP03

Description		2.0 m (6' 7") Arm	2.40 m (7' 10") Arm	2.92 m (9' 7") Arm	3.90 m (12' 10") Arm
Max digging reach	A	9140 mm (30' 0")	9500 mm (31' 2")	9980 mm (32' 9")	10910 mm (35' 10")
Max digging reach on ground	A'	8960 mm (29' 5")	9330 mm (30' 7")	9820 mm (32' 3")	10770 mm (35' 4")
Max digging depth	B	5820 mm (19' 1")	6220 mm (20' 5")	6730 mm (22' 1")	7720 mm (25' 4")
Max digging depth (8 ft level)	B'	5580 mm (18' 4")	6010 mm (19' 9")	6560 mm (21' 6")	7580 mm (24' 10")
Max vertical wall digging depth	C	5280 mm (17' 4")	5720 mm (18' 9")	6280 mm (20' 7")	7240 mm (23' 9")
Max digging height	D	9140 mm (30' 0")	9340 mm (30' 8")	9600 mm (31' 6")	10110 mm (33' 2")
Max dumping height	E	6330 mm (20' 9")	6520 mm (21' 5")	6780 mm (22' 3")	7290 mm (23' 11")
Min swing radius	F	3750 mm (12' 4")	3740 mm (12' 3")	3670 mm (12' 0")	3700 mm (12' 2")
Bucket digging force	SAE	133.4 [144.8] kN	133.4 [144.8] kN	133.4 [144.8] kN	133.4 [144.8] kN
		13600 [14770] kgf	13600 [14770] kgf	13600 [14770] kgf	13600 [14770] kgf
		29980 [32550] lbf	29980 [32550] lbf	29980 [32550] lbf	29980 [32550] lbf
	ISO	152.0 [165.0] kN	152.0 [165.0] kN	152.0 [165.0] kN	152.0 [165.0] kN
		15500 [16830] kgf	15500 [16830] kgf	15500 [16830] kgf	15500 [16830] kgf
		34170 [37100] lbf	34170 [37100] lbf	34170 [37100] lbf	34170 [37100] lbf
Arm digging force	SAE	144.2 [156.5] kN	119.6 [129.9] kN	102.0 [110.7] kN	84.3 [91.6] kN
		14700 [15960] kgf	12200 [13250] kgf	10400 [11290] kgf	8600 [9340] kgf
		32410 [35190] lbf	26900 [29210] lbf	22930 [24900] lbf	18960 [20590] lbf
	ISO	151.0 [164.0] kN	125.5 [136.3] kN	106.9 [116.1] kN	87.3 [94.8] kN
		15400 [16720] kgf	12800 [13900] kgf	10900 [11830] kgf	8900 [9660] kgf
		33950 [36860] lbf	28220 [30640] lbf	24030 [26090] lbf	19620 [21300] lbf

[] : Power boost

(2) 5.65 m (18' 5") 2-piece boom

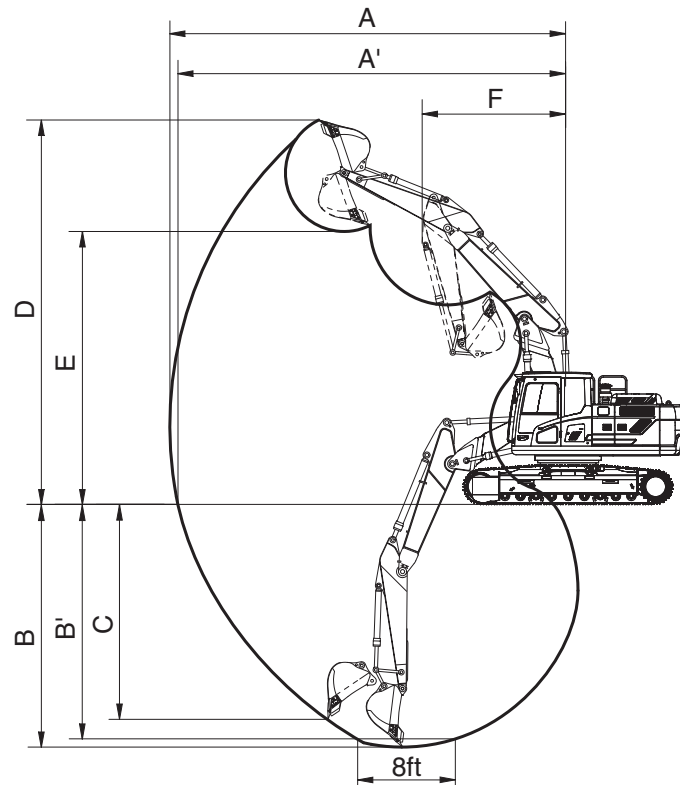

220F2SP53

Description		2.0 m (6' 7") Arm	2.4 m (7' 10") Arm	2.92 m (9' 7") Arm
Max digging reach	A	9120 mm (29'11")	9530 mm (31' 3")	10020 mm (32'10")
Max digging reach on ground	A'	8950 mm (29' 4")	9360 mm (30' 8")	9860 mm (32' 4")
Max digging depth	B	5480 mm (18' 0")	5880 mm (19' 3")	6400 mm (21' 0")
Max digging depth (8 ft level)	B'	5360 mm (17' 7")	5770 mm (18'11")	6290 mm (20' 8")
Max vertical wall digging depth	C	4540 mm (14'11")	5020 mm (16' 6")	5560 mm (18' 3")
Max digging height	D	10310 mm (33'10")	10670 mm (35' 0")	11090 mm (36' 5")
Max dumping height	E	7390 mm (24' 3")	7750 mm (25' 5")	8160 mm (26' 9")
Min swing radius	F	2870 mm (9' 5")	2660 mm (8' 9")	2530 mm (8' 4")
Bucket digging force	SAE	133.4 [144.8] kN	133.4 [144.8] kN	133.4 [144.8] kN
		13600 [14770] kgf	13600 [14770] kgf	13600 [14770] kgf
		29980 [32550] lbf	29980 [32550] lbf	29980 [32550] lbf
	ISO	152.0 [165.0] kN	152.0 [165.0] kN	152.0 [165.0] kN
		15500 [16830] kgf	15500 [16830] kgf	15500 [16830] kgf
		34170 [37100] lbf	34170 [37100] lbf	34170 [37100] lbf
Arm crowd force	SAE	144.2 [156.5] kN	119.6 [129.9] kN	102.0 [110.7] kN
		14700 [15960] kgf	12200 [13250] kgf	10400 [11290] kgf
		32410 [35190] lbf	26900 [29210] lbf	22930 [24900] lbf
	ISO	151.0 [164.0] kN	125.5 [136.3] kN	106.9 [116.1] kN
		15400 [16720] kgf	12800 [13900] kgf	10900 [11830] kgf
		33950 [36860] lbf	28220 [30640] lbf	24030 [26090] lbf

[] : Power boost

2) HX220 L LONG REACH

(1) 8.2 m (26' 11") boom

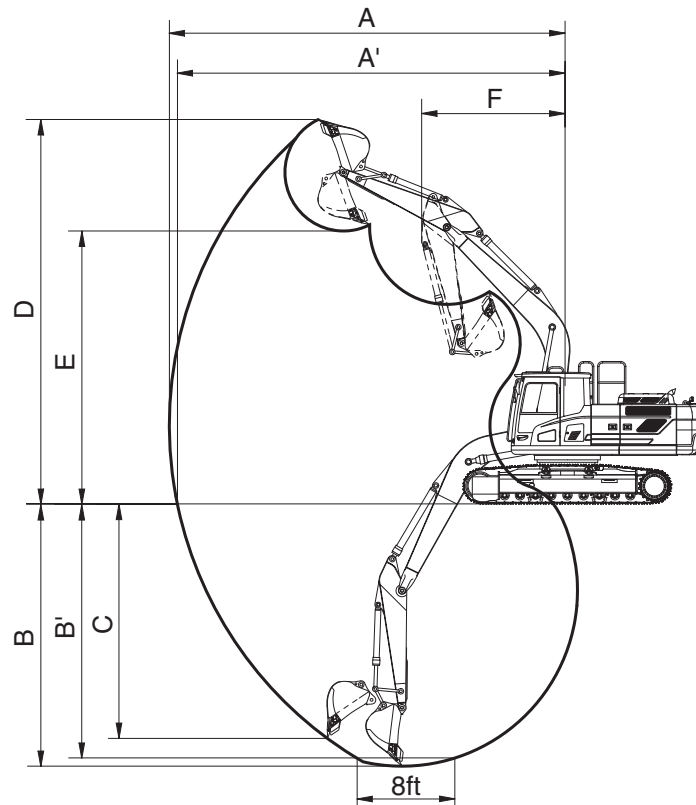

220F2SP05

Description		6.3 m (20' 8") Arm	
Max digging reach	A	15220 (50' 0")	
Max digging reach on ground	A'	15120 (49' 7")	
Max digging depth	B	11760 (38' 7")	
Max digging depth (8 ft level)	B'	11650 (38' 3")	
Max vertical wall digging depth	C	9610 (31' 6")	
Max digging height	D	12550 (41' 2")	
Max dumping height	E	10280 (33' 8")	
Min swing radius	F	4870 (16' 0")	
Bucket digging force	SAE	72.6 kN	
		7400 kgf	
		16310 lbf	
	ISO	83.4 kN	
		8500 kgf	
		18740 lbf	
Arm crowd force	SAE	49.0 kN	
		5000 kgf	
		11020 lbf	
	ISO	50.0 kN	
		5100 kgf	
		11240 lbf	

3) HX220 L HIGH WALKER

(1) 5.68 m (18' 8") boom

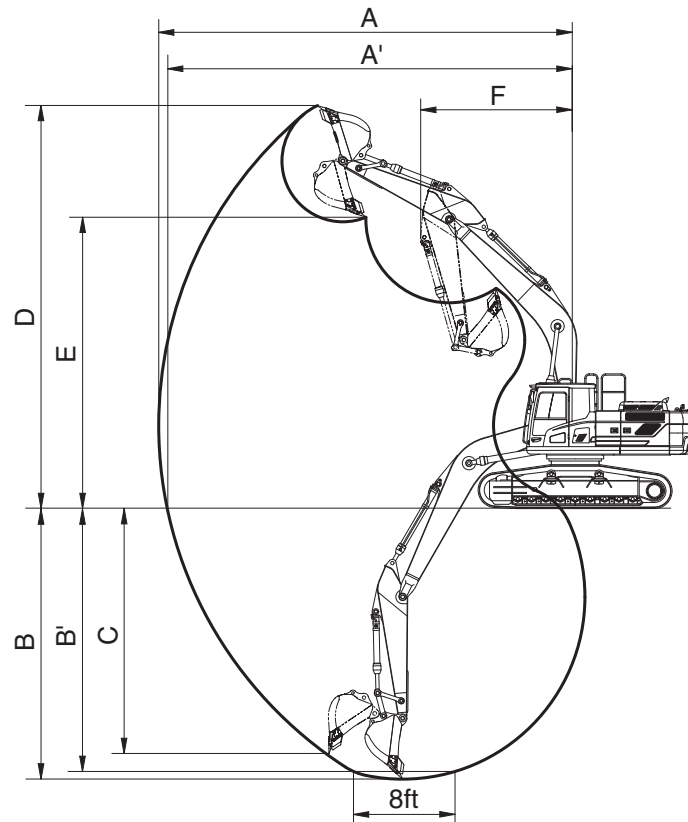

220F2SP06

Description		2.0 m (6' 7") Arm	2.40 m (7' 10") Arm	2.92 m (9' 7") Arm	3.90 m (12'10") Arm
Max digging reach	A	9140 mm (30' 0")	9500 mm (31' 2")	9980 mm (32' 9")	10910 mm (35'10")
Max digging reach on ground	A'	8920 mm (29' 3")	9290 mm (30' 6")	9820 mm (32' 3")	10730 mm (35' 2")
Max digging depth	B	5630 mm (18' 6")	6010 mm (19' 9")	6550 mm (21' 6")	7530 mm (24' 8")
Max digging depth (8 ft level)	B'	5390 mm (17' 8")	5820 mm (19' 1")	6380 mm (20'11")	7390 mm (24' 3")
Max vertical wall digging depth	C	5090 mm (16' 8")	5630 mm (18' 6")	6100 mm (20' 0")	7050 mm (23' 1")
Max digging height	D	9330 mm (30' 7")	9530 mm (31' 3")	9780 mm (32' 1")	10300 mm (33' 9")
Max dumping height	E	6520 mm (21' 5")	6710 mm (22' 0")	6960 mm (22'10")	7480 mm (24' 6")
Min swing radius	F	3750 mm (12' 4")	3740 mm (12' 3")	3670 mm (12' 0")	3700 mm (12' 2")
Bucket digging force	SAE	133.4 [144.8] kN	133.4 [144.8] kN	133.4 [144.8] kN	133.4 [144.8] kN
		13600 [14770] kgf	13600 [14770] kgf	13600 [14770] kgf	13600 [14770] kgf
		29980 [32550] lbf	29980 [32550] lbf	29980 [32550] lbf	29980 [32550] lbf
	ISO	152.0 [165.0] kN	152.0 [165.0] kN	152.0 [165.0] kN	152.0 [165.0] kN
		15500 [16830] kgf	15500 [16830] kgf	15500 [16830] kgf	15500 [16830] kgf
		34170 [37100] lbf	34170 [37100] lbf	34170 [37100] lbf	34170 [37100] lbf
Arm crowd force	SAE	144.2 [156.5] kN	119.6 [129.9] kN	102.0 [110.7] kN	84.3 [91.6] kN
		14700 [15960] kgf	12200 [13250] kgf	10400 [11290] kgf	8600 [9340] kgf
		32410 [35190] lbf	26900 [29210] lbf	22930 [24900] lbf	18960 [20590] lbf
	ISO	151.0 [164.0] kN	125.5 [136.3] kN	106.9 [116.1] kN	87.3 [94.8] kN
		15400 [16720] kgf	12800 [13900] kgf	10900 [11830] kgf	8900 [9660] kgf
		33950 [36860] lbf	28220 [30640] lbf	24030 [26090] lbf	19620 [21300] lbf

[] : Power boost

4. WEIGHT

1) HX220 L

Item	HX220 L	
	kg	lb
Upper structure assembly		
· Main frame weld assembly	1880	4140
· Engine assembly	520	1150
· Main pump assembly	140	310
· Main control valve assembly	230	507
· Swing motor assembly	240	530
· Hydraulic oil tank assembly	240	530
· Fuel tank assembly	195	430
· Counterweight	3800	8380
· Cab assembly	490	1080
Lower chassis assembly		
· Track frame weld assembly	2720	6000
· Swing bearing	290	640
· Travel motor assembly	300	660
· Turning joint	55	120
· Sprocket	55	120
· Track recoil spring	130	290
· Idler	155	340
· Carrier roller	20	45
· Track roller	48	106
· Track-chain assembly (600 mm standard triple grouser shoe)	1360	3000
Front attachment assembly		
· 5.68 m boom assembly	1520	3350
· 2.92 m arm assembly	760	1680
· 0.92 m ³ SAE heaped bucket	820	1810
· Boom cylinder assembly	180	400
· Arm cylinder assembly	290	640
· Bucket cylinder assembly	175	390
· Bucket control link assembly	170	370

※ This information is different with operating and transportation weight because it is not including harness, pipe, oil, fuel so on.

※ Refer to Transportation for actual weight information and Specifications for operating weight.

2) HX220 L LONG REACH

Item	HX220 L LONG REACH	
	kg	lb
Upper structure assembly		
· Main frame weld assembly	1880	4140
· Engine assembly	520	1150
· Main pump assembly	140	310
· Main control valve assembly	230	507
· Swing motor assembly	240	530
· Hydraulic oil tank assembly	240	530
· Fuel tank assembly	195	430
· Counterweight	5300	11680
· Cab assembly	490	1080
Lower chassis assembly		
· Track frame weld assembly	2720	6000
· Swing bearing	290	640
· Travel motor assembly	300	660
· Turning joint	55	120
· Sprocket	55	120
· Track recoil spring	130	290
· Idler	155	340
· Carrier roller	20	45
· Track roller	48	106
· Track-chain assembly (600 mm standard triple grouser shoe)	1735	3820
Front attachment assembly		
· 8.2 m boom assembly	2105	4640
· 6.3 m arm assembly	1100	2430
· 0.52 m ³ SAE heaped bucket	460	1010
· Boom cylinder assembly	180	400
· Arm cylinder assembly	270	600
· Bucket cylinder assembly	130	290
· Bucket control link assembly	170	370

※ This information is different with operating and transportation weight because it is not including harness, pipe, oil, fuel so on.

※ Refer to Transportation for actual weight information and Specifications for operating weight.

3) HX220 L HIGH WALKER

Item	HX220 L HIGH WALKER	
	kg	lb
Upper structure assembly		
· Main frame weld assembly	1950	4300
· Engine assembly	520	1150
· Main pump assembly	140	310
· Main control valve assembly	230	507
· Swing motor assembly	240	530
· Hydraulic oil tank assembly	240	530
· Fuel tank assembly	195	430
· Counterweight	3800	8380
· Cab assembly	490	1080
Lower chassis assembly		
· Track frame weld assembly	3730	8220
· Swing bearing	290	640
· Travel motor assembly	300	660
· Turning joint	55	120
· Sprocket	55	120
· Track recoil spring	130	290
· Idler	155	340
· Carrier roller	20	45
· Track roller	48	106
· Track-chain assembly (600 mm standard triple grouser shoe)	1360	3000
Front attachment assembly		
· 5.68 m boom assembly	1520	3350
· 2.92 m arm assembly	760	1680
· 0.92 m ³ SAE heaped bucket	820	1810
· Boom cylinder assembly	180	400
· Arm cylinder assembly	290	640
· Bucket cylinder assembly	175	390
· Bucket control link assembly	170	370

※ This information is different with operating and transportation weight because it is not including harness, pipe, oil, fuel so on.

※ Refer to Transportation for actual weight information and Specifications for operating weight.

5. LIFTING CAPACITIES

1) HX220 L









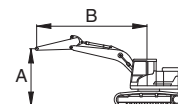

Unit : mm

Model	Boom	Boom	Arm	Counterweight	Shoe	Dozer		Outrigger	
	Type	Length	Length	Weight (kg)	Width	Front	Rear	Front	Rear
HX220 L	Mono	5680	2000	3800	600	-	-	-	-

·  : Rating over-front

·  : Rating over-side or 360 degree



Lift-point height (A)	Lift-point radius (B)								At max. reach		
	3.0 m (9.8 ft)		4.5 m (14.8 ft)		6.0 m (19.7 ft)		7.5 m (24.6 ft)		Capacity	Reach	
											m (ft)
7.5m 24.6ft	kg lb								*5730 *12630	*5730 *12630	5.01 (16.4)
6.0m 19.7ft	kg lb				*5470 *12060	5200 11460			*5540 *12210	4710 10380	6.35 (20.8)
4.5m 14.8ft	kg lb		*6920 *15260	*6920 *15260	*5830 *12850	5070 11180			*5580 *12300	3860 8510	7.14 (23.4)
3.0m 9.8ft	kg lb		*8730 *19250	7290 16070	*6570 *14480	4850 10690	5670 12500	3500 7720	5610 12370	3460 7630	7.55 (24.8)
1.5m 4.9ft	kg lb				*7300 *16090	4660 10270	5590 12320	3420 7540	5440 11990	3330 7340	7.64 (25.1)
0.0m 0.0ft	kg lb		*10560 *23280	6770 14930	7670 16910	4540 10010			5620 12390	3430 7560	7.42 (24.4)
-1.5m -4.9ft	kg lb		*10270 *22640	6790 14970	*7640 *16840	4530 9990			6290 13870	3810 8400	6.88 (22.6)
-3.0m -9.8ft	kg lb	*12430 *27400	*12430 *27400	*9170 *20220	6930 15280				*6710 *14790	4770 10520	5.90 (19.3)
-4.5m -14.8ft	kg lb										

※ Note

1. Lifting capacity are based on SAE J1097 and ISO 10567.
2. Lifting capacity of the ROBEX series does not exceed 75% of tipping load with the machine on firm, level ground or 87% of full hydraulic capacity.
3. The lift-point is bucket mounting pin on the arm (without bucket mass).
4. *indicates load limited by hydraulic capacity.

※ Lifting capacities are based upon a standard machine conditions.

Lifting capacities will vary with different work tools, ground conditions and attachments.

The difference between the weight of a work tool attachment must be subtracted.

Consult your Hyundai dealer regarding the lifting capacities for specific work tools and attachments.

▲ Failure to comply to the rated load can cause possible personal injury or property damage.

Make adjustments to the rated load as necessary for non-standard configurations.









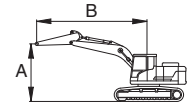

Unit : mm

Model	Boom	Boom	Arm	Counterweight	Shoe	Dozer		Outrigger	
	Type	Length	Length	Weight (kg)	Width	Front	Rear	Front	Rear
HX220 L	Mono	5680	2400	3800	600	-	-	-	-

·  : Rating over-front

·  : Rating over-side or 360 degree



Lift-point height (A)		Lift-point radius (B)								At max. reach		
		3.0 m (9.8 ft)		4.5 m (14.8 ft)		6.0 m (19.7 ft)		7.5 m (24.6 ft)		Capacity		Reach
												m (ft)
7.5m 24.6ft	kg lb									*5080 *11200	*5080 *11200	5.59 (18.3)
6.0m 19.7ft	kg lb					*5020 *11070	*5020 *11070			*4610 *10160	4230 9330	6.82 (22.4)
4.5m 14.8ft	kg lb			*6370 *14040	*6370 *14040	*5470 *12060	5100 11240	*5030 *11090	3580 7890	*4490 *9900	3530 7780	7.56 (24.8)
3.0m 9.8ft	kg lb			*8180 *18030	7390 16290	*6260 *13800	4870 10740	*5450 *12020	3500 7720	*4580 *10100	3200 7050	7.94 (26.1)
1.5m 4.9ft	kg lb			*9750 *21500	6940 15300	*7060 *15560	4650 10250	5570 12280	3400 7500	*4860 *10710	3080 6790	8.03 (26.3)
0.0m 0.0ft	kg lb			*10450 *23040	6740 14860	*7590 *16730	4510 9940	5500 12130	3340 7360	5170 11400	3150 6940	7.83 (25.7)
-1.5m -4.9ft	kg lb	*10870 *23960	*10870 *23960	*10370 *22860	6720 14820	7600 16760	4470 9850			5710 12590	3460 7630	7.31 (24.0)
-3.0m -9.8ft	kg lb	*13320 *29370	13310 29340	*9530 *21010	6820 15040	*6990 *15410	4550 10030			*6330 *13960	4200 9260	6.40 (21.0)
-4.5m -14.8ft	kg lb			*7170 *15810	7120 15700					*6360 *14020	*6360 *14020	4.87 (16.0)

Unit : mm

Model	Boom	Boom	Arm	Counterweight	Shoe	Dozer		Outrigger	
	Type	Length	Length	Weight (kg)	Width	Front	Rear	Front	Rear
HX220 L	Mono	5680	2920	3800	600	-	-	-	-



: Rating over-front



: Rating over-side or 360 degree

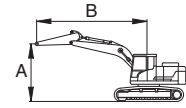

Lift-point height (A)		Lift-point radius (B)										At max. reach		
		1.5 m (4.9 ft)		3.0 m (9.8 ft)		4.5 m (14.8 ft)		6.0 m (19.7 ft)		7.5 m (24.6 ft)		Capacity		Reach
														m (ft)
7.5m	kg							*4480	*4480			*3370	*3370	6.27
24.6ft	lb							*9880	*9880			*7430	*7430	(20.6)
6.0m	kg							*4460	*4460			*3100	*3100	7.39
19.7ft	lb							*9830	*9830			*6830	*6830	(24.2)
4.5m	kg							*4980	*4980	*4730	3600	*3020	*3020	8.07
14.8ft	lb							*10980	*10980	*10430	7940	*6660	*6660	(26.5)
3.0m	kg					*7440	*7440	*5820	4900	*5090	3500	*3070	2890	8.43
9.8ft	lb					*16400	*16400	*12830	10800	*11220	7720	*6770	6370	(27.7)
1.5m	kg					*9180	6990	*6700	4650	*5540	3380	*3250	2790	8.51
4.9ft	lb					*20240	15410	*14770	10250	*12210	7450	*7170	6150	(27.9)
0.0m	kg			*5950	*5950	*10180	6710	*7360	4480	5450	3280	*3590	2840	8.32
0.0ft	lb			*13120	*13120	*22440	14790	*16230	9880	12020	7230	*7910	6260	(27.3)
-1.5m	kg	*6530	*6530	*10420	*10420	*10390	6630	7520	4400	5410	3260	*4210	3080	7.84
-4.9ft	lb	*14400	*14400	*22970	*22970	*22910	14620	16580	9700	11930	7190	*9280	6790	(25.7)
-3.0m	kg	*11150	*11150	*14230	13050	*9860	6690	*7280	4430			*5430	3630	7.00
-9.8ft	lb	*24580	*24580	*31370	28770	*21740	14750	*16050	9770			*11970	8000	(23.0)
-4.5m	kg			*11660	*11660	*8220	6900					*6120	5030	5.64
-14.8ft	lb			*25710	*25710	*18120	15210					*13490	11090	(18.5)

Unit : mm

Model	Boom	Boom	Arm	Counterweight	Shoe	Dozer		Outrigger	
	Type	Length	Length	Weight (kg)	Width	Front	Rear	Front	Rear
HX220 L	Mono	5680	3900	3800	600	-	-	-	-



: Rating over-front



: Rating over-side or 360 degree

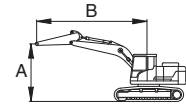

Load point height		Load radius												At max. reach			
		1.5 m (5 ft)		3.0 m (10 ft)		4.5 m (15 ft)		6.0 m (20 ft)		7.5 m (25 ft)		9.0 m (30 ft)		Capacity		Reach	
																m (ft)	
7.5 m (25 ft)	kg														*2330	*2330	7.47 (24.5)
	lb														*5140	*5140	
6.0 m (20 ft)	kg								*3690	*3690					*2170	*2170	8.43 (27.7)
	lb								*8140	*8140					*4790	*4790	
4.5 m (15 ft)	kg								*3930	3650	*2300	*2300	*2120	*2120	*2120	*2120	9.04 (29.7)
	lb								*8650	8040	*5080	*5080	*4670	*4670	*4670	*4670	
3.0 m (10 ft)	kg					*5880	*5880	*4880	*4880	*4380	3500	*3530	2580	*2150	*2150	*2150	9.37 (30.7)
	lb					*12960	*12960	*10760	*10760	*9670	7720	*7770	5690	*4730	*4730	*4730	
1.5 m (5 ft)	kg			*8720	*8720	*7860	7140	*5890	4670	*4930	3340	*4080	2500	*2250	*2250	*2250	9.45 (31.0)
	lb			*19230	*19230	*17320	15740	*12980	10300	*10880	7370	*8990	5520	*4960	*4960	*4960	
Ground Line	kg			*7190	*7190	*9340	6680	*6760	4420	5380	3200	*3900	2440	*2440	2330	9.28 (30.4)	
	lb			*15860	*15860	*20600	14720	*14890	9750	11850	7060	*8600	5380	*5390	5140	5140	
-1.5 m (-5 ft)	kg	*5400	*5400	*9330	*9330	*10080	6460	*7300	4270	5280	3120			*2780	2470	8.85 (29.0)	
	lb	*11900	*11900	*20570	*20570	*22220	14240	*16090	9410	11640	6870			*6130	5450	5450	
-3.0 m (-10 ft)	kg	*8470	*8470	*12990	12530	*10090	6420	7350	4230	5270	3110			*3380	2800	8.13 (26.7)	
	lb	*18680	*18680	*28630	27620	*22250	14150	16200	9320	11620	6850			*7450	6180	6180	
-4.5 m (-15 ft)	kg	*12320	*12320	*13640	12800	*9290	6530	*6780	4310					*4640	3520	7.01 (23.0)	
	lb	*27160	*27160	*30080	28230	*20490	14400	*14940	9500					*10220	7760	7760	
-6.0 m (-20 ft)	kg			*10260	*10260	*6970	6850							*5560	5530	5.24 (17.2)	
	lb			*22620	*22620	*15360	15110							*12260	12200	12200	

Unit : mm

Model	Boom	Boom	Arm	Counterweight	Shoe	Dozer		Outrigger	
	Type	Length	Length	Weight (kg)	Width	Front	Rear	Front	Rear
HX220 L	2-piece	5650	2000	3800	600	-	-	-	-



: Rating over-front



: Rating over-side or 360 degree

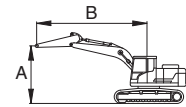

Lift-point height (A)		Lift-point radius (B)								At max. reach		
		3.0 m (9.8 ft)		4.5 m (14.8 ft)		6.0 m (19.7 ft)		7.5 m (24.6 ft)		Capacity		Reach
												m (ft)
10.5m	kg									*6180	*6180	4.64
35.0ft	lb									*13620	*13620	(15.2)
9.0m	kg									*6520	*6520	4.61
30.0ft	lb									*14370	*14370	(15.1)
7.5m	kg			*6710	*6710					*5270	4060	6.67
24.6ft	lb			*14790	*14790					*11620	8950	(21.9)
6.0m	kg			6780	*6870	*5850	4780			*4850	2970	7.80
19.7ft	lb			15150	*15150	*12900	10540			*10690	6550	(25.6)
4.5m	kg	*11340	*11340	*7750	7500	*6130	4610			4360	2470	8.45
14.8ft	lb	*25000	*25000	*17090	16530	*13510	10160			9610	5450	(27.7)
3.0m	kg			*8930	6810	*6590	4330	5200	2950	4030	2250	8.75
9.8ft	lb			*19690	15010	*14530	9550	11460	6500	8880	4960	(28.7)
1.5m	kg			*9600	6250	*6900	4060	5070	2830	3980	2200	8.75
4.9ft	lb			*21160	13780	*15210	8950	11180	6240	8770	4850	(28.7)
0.0m	kg			*9290	6020	*6800	3890	4990	2760	*3940	2330	8.44
0.0ft	lb			*20480	13270	*14990	8580	11000	6080	*8690	5140	(27.7)
-1.5m	kg	*9840	*9840	*8130	6010	*6060	3850			*3360	2710	7.77
-4.9ft	lb	*21690	*21690	*17920	13250	*13360	8490			*7410	5970	(25.5)
-3.0m	kg			*6030	*6030	*4250	3970					
-9.8ft	lb			*13290	*13290	*9370	8750					









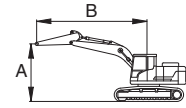

Unit : mm

Model	Boom	Boom	Arm	Counterweight	Shoe	Dozer		Outrigger	
	Type	Length	Length	Weight (kg)	Width	Front	Rear	Front	Rear
HX220 L	2-piece	5650	2400	3800	600	-	-	-	-

·  : Rating over-front

·  : Rating over-side or 360 degree



Lift-point height (A)		Lift-point radius (B)								At max. reach		
		3.0 m (9.8 ft)		4.5 m (14.8 ft)		6.0 m (19.7 ft)		7.5 m (24.6 ft)		Capacity		Reach
												m (ft)
9.0m	kg									*5690	*5690	5.4
30.0ft	lb									*12540	*12540	(17.7)
7.5m	kg			*5860	*5860					*4850	3560	7.19
24.6ft	lb			*12920	*12920					*10690	7850	(23.6)
6.0m	kg			*6410	*6410	*5520	4860			*4510	2690	8.23
19.7ft	lb			*14130	*14130	*12170	10710			*9940	5930	(27.0)
4.5m	kg	*10290	*10290	*7300	*7300	*5860	4670	*4360	3080	4020	2260	8.85
14.8ft	lb	*22690	*22690	*16090	*16090	*12920	10300	*9610	6790	8860	4980	(29.0)
3.0m	kg			*8550	6940	*6370	4370	*5170	2960	3740	2060	9.14
9.8ft	lb			*18850	15300	*14040	9630	*11140	6530	8250	4540	(30.0)
1.5m	kg			*9440	6320	*6780	4070	5070	2820	3690	2020	9.13
4.9ft	lb			*20810	13930	*14950	8970	11180	6220	8140	4450	(30.0)
0.0m	kg	*8600	*8600	*9420	6000	*6820	3870	4960	2720	*3760	2120	8.84
0.0ft	lb	*18960	*18960	*20770	13230	*15040	8530	10930	6000	*8290	4670	(29.0)
-1.5m	kg	*11240	*11240	*8510	5930	*6280	3800	*4460	2710	*3310	2440	8.21
-4.9ft	lb	*24780	*24780	*18760	13070	*13850	8380	*9830	5970	*7300	5380	(26.9)
-3.0m	kg			*6700	6040	*4870	3860					
-9.8ft	lb			*14770	13320	*10740	8510					









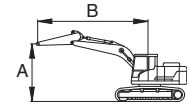

Unit : mm

Model	Boom	Boom	Arm	Counterweight	Shoe	Dozer		Outrigger	
	Type	Length	Length	Weight (kg)	Width	Front	Rear	Front	Rear
HX220 L	2-piece	5650	2920	3800	600	-	-	-	-

·  : Rating over-front

·  : Rating over-side or 360 degree



Lift-point height (A)		Lift-point radius (B)								At max. reach		
		3.0 m (9.8 ft)		4.5 m (14.8 ft)		6.0 m (19.7 ft)		7.5 m (24.6 ft)		Capacity		Reach
												m (ft)
9.0m	kg			*3290	*3290					*4590	*4590	6.28
30.0ft	lb			*7250	*7250					*10120	*10120	(20.6)
7.5m	kg					*3520	*3520			*4020	3060	7.83
24.6ft	lb					*7760	*7760			*8860	6750	(25.7)
6.0m	kg			*5160	*5160	*4870	*4870	*2440	*2440	*3790	2370	8.79
19.7ft	lb			*11380	*11380	*10740	*10740	*5380	*5380	*8360	5220	(28.8)
4.5m	kg			*6680	*6680	*5480	4750	*4380	3140	3650	2020	9.36
14.8ft	lb			*14730	*14730	*12080	10470	*9660	6920	8050	4450	(30.7)
3.0m	kg	*12620	*12620	*8000	7130	*6060	4430	*4970	2990	3400	1850	9.63
9.8ft	lb	*27820	*27820	*17640	15720	*13360	9770	*10960	6590	7500	4080	(31.6)
1.5m	kg	*8680	*8680	*9130	6430	*6580	4100	5070	2820	3350	1800	9.63
4.9ft	lb	*19140	*19140	*20130	14180	*14510	9040	11180	6220	7390	3970	(31.6)
0.0m	kg	*9390	*9390	*9450	6000	*6780	3850	4930	2690	3500	1880	9.35
0.0ft	lb	*20700	*20700	*20830	13230	*14950	8490	10870	5930	7720	4140	(30.7)
-1.5m	kg	*12500	11770	*8880	5850	*6460	3730	*4770	2630	*3200	2130	8.77
-4.9ft	lb	*27560	25950	*19580	12900	*14240	8220	*10520	5800	*7050	4700	(28.8)
-3.0m	kg	*9950	*9950	*7420	5890	*5420	3750					
-9.8ft	lb	*21940	*21940	*16360	12990	*11950	8270					

2) HX220 L LONG REACH

Unit : mm

Model	Boom	Boom	Arm	Counterweight	Shoe	Dozer		Outrigger	
	Type	Length	Length	Weight (kg)	Width	Front	Rear	Front	Rear
HX220 L	Mono	8200	6300	5300	800	-	-	-	-



: Rating over-front



: Rating over-side or 360 degree

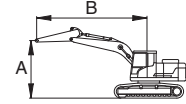

Lift-point height (A)	Lift-point radius (B)																		At max. reach						
	1.5 m (4.9 ft)		3.0 m (9.8 ft)		4.5 m (14.8 ft)		6.0 m (19.7 ft)		7.5 m (24.6 ft)		9.0 m (29.5 ft)		10.5 m (34.4 ft)		12.0 m (39.4 ft)		13.5 m (44.3 ft)		Capacity	Reach					
																					m (ft)				
10.5m 34.4ft	kg lb													*1220 *2690	*1220 *2690					*900 *1980	*900 *1980	10.88 (35.7)			
9.0m 29.5ft	kg lb																				*850 *1870	*850 *1870	11.94 (39.2)		
7.5m 24.6ft	kg lb													*1910 *4210	*1910 *4210	*1450 *3200	*1450 *3200				*820 *1810	*820 *1810	12.74 (41.8)		
6.0m 19.7ft	kg lb													*2040 *4500	*2040 *4500	*1810 *3990	*1810 *3990				*820 *1810	*820 *1810	13.32 (43.7)		
4.5m 14.8ft	kg lb												*2340 *5160	*2340 *5160	*2230 *4920	*2230 *4920	*2110 *4650	2020 4450	*1080 *2380	*1080 *2380	*830 *1830	*830 *1830	13.70 (45.0)		
3.0m 9.8ft	kg lb												*3040 *6700	*3040 *6700	*2680 *5910	*2680 *5910	*2460 *5420	2450 5400	*2310 *5090	1930 4250	*1370 *3020	*1370 *3020	*860 *1900	*860 *1900	13.92 (45.7)
1.5m 4.9ft	kg lb			*2830 *6240	*2830 *6240	*6430 *14180	*6430 *14180	*4550 *10030	*4550 *10030	*3600 *7940	*3600 *7940	*3060 *6750	2950 6500	*2710 *5970	2320 5110	*2480 *5470	1840 4060	*1520 *3350	1480 3260	*910 *2010	*910 *2010	13.97 (45.8)			
0.0m 0.0ft	kg lb			*2450 *5400	*2450 *5400	*6290 *13870	*6290 *13870	*5350 *11790	4830 10650	*4130 *9110	3570 7870	*3410 *7520	2760 6080	*2950 *6500	2190 4830	*2640 *5820	1760 3880	*1500 *3310	1430 3150	*980 *2160	*980 *2160	13.85 (45.4)			
-1.5m -4.9ft	kg lb	*2030 *4480	*2030 *4480	*3010 *6640	*3010 *6640	*5640 *12430	*5640 *12430	*5930 *13070	4510 9940	*4550 *10030	3350 7390	*3710 *8180	2610 5750	*3160 *6970	2080 4590	*2790 *6150	1690 3730	*1200 *2650	*1200 *2650	*1080 *2380	*1080 *2380	13.57 (44.5)			
-3.0m -9.8ft	kg lb	*2910 *6420	*2910 *6420	*3840 *8470	*3840 *8470	*6090 *13430	*6090 *13430	*6280 *13850	4340 9570	*4840 *10670	3210 7080	*3930 *8660	2500 5510	*3320 *7320	2010 4430	*2880 *6350	1650 3640			*1220 *2690	*1220 *2690	13.11 (43.0)			
-4.5m -14.8ft	kg lb	*3830 *8440	*3830 *8440	*4830 *10650	*4830 *10650	*7050 *15540	6490 14310	*6400 *14110	4280 9440	*4980 *10980	3150 6940	*4050 *8930	2450 5400	*3390 *7470	1980 4370	*2400 *5290	1650 3640			*1420 *3130	*1420 *3130	12.45 (40.8)			
-6.0m -19.7ft	kg lb	*4840 *10670	*4840 *10670	*6010 *13250	*6010 *13250	*8470 *18670	6590 14530	*6310 *13910	4310 9500	*4950 *10910	3150 6940	*4020 *8860	2460 5420	*3330 *7340	2000 4410					*1750 *3860	*1750 *3860	11.55 (37.9)			
-7.5m -24.6ft	kg lb	*5980 *13180	*5980 *13180	*7450 *16420	*7450 *16420	*7880 *17370	6780 14950	*5950 *13120	4420 9740	*4690 *10340	3230 7120	*3780 *8330	2530 5580							*2330 *5140	2120 4670	10.36 (34.0)			
-9.0m -29.5ft	kg lb			*9330 *20570	*9330 *20570	*6820 *15040	*6820 *15040	*5210 *11490	4620 10190	*4070 *8970	3390 7470									*3250 *7170	2790 6150	8.76 (28.7)			
-10.5m -34.4ft	kg lb																								

※ Note

1. Lifting capacity are based on SAE J1097 and ISO 10567.
2. Lifting capacity of the ROBEX series does not exceed 75% of tipping load with the machine on firm, level ground or 87% of full hydraulic capacity.
3. The lift-point is bucket mounting pin on the arm (without bucket mass).
4. *indicates load limited by hydraulic capacity.

※ Lifting capacities are based upon a standard machine conditions.

Lifting capacities will vary with different work tools, ground conditions and attachments.

The difference between the weight of a work tool attachment must be subtracted.

Consult your Hyundai dealer regarding the lifting capacities for specific work tools and attachments.

▲ Failure to comply to the rated load can cause possible personal injury or property damage.

Make adjustments to the rated load as necessary for non-standard configurations.

3) HX220 L HIGH WALKER









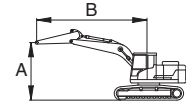

Unit : mm

Model	Boom	Boom	Arm	Counterweight	Shoe	Dozer		Outrigger	
	Type	Length	Length	Weight (kg)	Width	Front	Rear	Front	Rear
HX220 L	Mono	5680	2000	3800	600	-	-	-	-

·  : Rating over-front

·  : Rating over-side or 360 degree



Lift-point height (A)		Lift-point radius (B)								At max. reach		
		3.0 m (9.8 ft)		4.5 m (14.8 ft)		6.0 m (19.7 ft)		7.5 m (24.6 ft)		Capacity		Reach
												m (ft)
7.5m 24.6ft	kg lb									*5660 *12480	*5660 *12480	5.31 (17.4)
6.0m 19.7ft	kg lb					*5480 *12080	*5480 *12080			*5540 *12210	*5540 *12210	6.53 (21.4)
4.5m 14.8ft	kg lb			*7230 *15940	*7230 *15940	*5950 *13120	*5950 *13120			*5600 *12350	4710 10380	7.24 (23.8)
3.0m 9.8ft	kg lb					*6710 *14790	6070 13380	*5780 *12740	4390 9680	*5760 *12700	4310 9500	7.59 (24.9)
1.5m 4.9ft	kg lb					*7400 *16310	5880 12960	5920 13050	4310 9500	5780 12740	4210 9280	7.62 (25.0)
0.0m 0.0ft	kg lb			*10560 *23280	8790 19380	*7750 *17090	5780 12740			6060 13360	4390 9680	7.35 (24.1)
-1.5m -4.9ft	kg lb	*13010 *28680	*13010 *28680	*10140 *22350	8830 19470	*7550 *16640	5790 12760			*6520 *14370	4970 10960	6.73 (22.1)
-3.0m -9.8ft	kg lb	*11970 *26390	*11970 *26390	*8830 *19470	*8830 *19470					*6730 *14840	6460 14240	5.66 (18.6)

※ Note

1. Lifting capacity are based on SAE J1097 and ISO 10567.
2. Lifting capacity of the ROBEX series does not exceed 75% of tipping load with the machine on firm, level ground or 87% of full hydraulic capacity.
3. The lift-point is bucket mounting pin on the arm (without bucket).
4. *indicates load limited by hydraulic capacity.

※ Lifting capacities are based upon a standard machine conditions.

Lifting capacities will vary with different work tools, ground conditions and attachments.

The difference between the weight of a work tool attachment must be subtracted.

Consult your Hyundai dealer regarding the lifting capacities for specific work tools and attachments.

▲ Failure to comply to the rated load can cause possible personal injury or property damage.

Make adjustments to the rated load as necessary for non-standard configurations.

Unit : mm

Model	Boom	Boom	Arm	Counterweight	Shoe	Dozer		Outrigger	
	Type	Length	Length	Weight (kg)	Width	Front	Rear	Front	Rear
HX220 L	Mono	5680	2400	3800	600	-	-	-	-



: Rating over-front



: Rating over-side or 360 degree

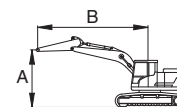

Lift-point height (A)		Lift-point radius (B)								At max. reach		
		3.0 m (9.8 ft)		4.5 m (14.8 ft)		6.0 m (19.7 ft)		7.5 m (24.6 ft)		Capacity		Reach
												m (ft)
7.5m	kg									*4950	*4950	5.86
24.6ft	lb									*10910	*10910	(19.2)
6.0m	kg					*5060	*5060			*4570	*4570	6.99
19.7ft	lb					*11160	*11160			*10080	*10080	(22.9)
4.5m	kg			*6670	*6670	*5600	*5600	*5220	4470	*4490	4330	7.65
14.8ft	lb			*14700	*14700	*12350	*12350	*11510	9850	*9900	9550	(25.1)
3.0m	kg			*8510	*8510	*6410	6090	*5510	4380	*4610	3990	7.98
9.8ft	lb			*18760	*18760	*14130	13430	*12150	9660	*10160	8800	(26.2)
1.5m	kg			*9950	8920	*7180	5880	*5870	4290	*4940	3900	8.01
4.9ft	lb			*21940	19670	*15830	12960	*12940	9460	*10890	8600	(26.3)
0.0m	kg			*10490	8750	*7640	5750	5840	4230	*5560	4040	7.76
0.0ft	lb			*23130	19290	*16840	12680	12870	9330	*12260	8910	(25.4)
-1.5m	kg	*12240	*12240	*10290	8750	*7620	5730			*6120	4510	7.18
-4.9ft	lb	*26980	*26980	*22690	19290	*16800	12630			*13490	9940	(23.5)
-3.0m	kg	*12900	*12900	*9270	8890	*6700	5840			*6370	5630	6.18
-9.8ft	lb	*28440	*28440	*20440	19600	*14770	12870			*14040	12410	(20.3)
-4.5m	kg											
-14.8ft	lb											









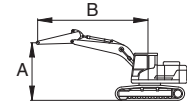



Unit : mm

Model	Boom	Boom	Arm	Counterweight	Shoe	Dozer		Outrigger	
	Type	Length	Length	Weight (kg)	Width	Front	Rear	Front	Rear
HX220 L	Mono	5680	2920	3800	600	-	-	-	-

·  : Rating over-front

·  : Rating over-side or 360 degree



Lift-point height (A)		Lift-point radius (B)										At max. reach		
		1.5 m (4.9 ft)		3.0 m (9.8 ft)		4.5 m (14.8 ft)		6.0 m (19.7 ft)		7.5 m (24.6 ft)		Capacity		Reach
														m (ft)
7.5m 24.6ft	kg lb							*4470 *9850	*4470 *9850			*3300 *7280	*3300 *7280	6.51 (21.4)
6.0m 19.7ft	kg lb							*4520 *9960	*4520 *9960	*3310 *7300	*3310 *7300	*3070 *6770	*3070 *6770	7.54 (24.7)
4.5m 14.8ft	kg lb					*5920 *13050	*5920 *13050	*5120 *11290	*5120 *11290	*4780 *10540	4490 9900	*3020 *6660	*3020 *6660	8.16 (26.8)
3.0m 9.8ft	kg lb					*7790 *17170	*7790 *17170	*5980 *13180	*5980 *13180	*5170 *11400	4380 9660	*3100 *6830	*3100 *6830	8.47 (27.8)
1.5m 4.9ft	kg lb					*9420 *20770	8960 19750	*6850 *15100	5870 12940	*5610 *12370	4260 9390	*3300 *7280	*3300 *7280	8.50 (27.9)
0.0m 0.0ft	kg lb			*6690 *14750	*6690 *14750	*10280 *22660	8710 19200	*7440 *16400	5710 12590	5780 12740	4170 9190	*3680 *8110	3660 8070	8.26 (27.1)
-1.5m -4.9ft	kg lb	*7340 *16180	*7340 *16180	*11370 *25070	*11370 *25070	*10350 *22820	8650 19070	*7610 *16780	5650 12460	5770 12720	4160 9170	*4370 *9630	4010 8840	7.71 (25.3)
-3.0m -9.8ft	kg lb	*12080 *26630	*12080 *26630	*13890 *30620	*13890 *30620	*9670 *21320	8740 19270	*7110 *15670	5700 12570			*5790 *12760	4830 10650	6.80 (22.3)
-4.5m -14.8ft	kg lb			*10960 *24160	*10960 *24160	*7690 *16950	*7690 *16950					*6120 *13490	*6120 *13490	5.31 (17.4)

Unit : mm

Model	Boom	Boom	Arm	Counterweight	Shoe	Dozer		Outrigger	
	Type	Length	Length	Weight (kg)	Width	Front	Rear	Front	Rear
HX220 L	Mono	5680	3900	3800	600	-	-	-	-



: Rating over-front



: Rating over-side or 360 degree

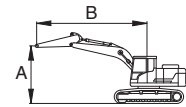

Lift-point height (A)		Lift-point radius (B)												At max. reach		
		1.5 m (4.9 ft)		3.0 m (9.8 ft)		4.5 m (14.8 ft)		6.0 m (19.7 ft)		7.5 m (24.6 ft)		9.0 m (29.5 ft)		Capacity	Reach	
																m (ft)
7.5m	kg									*2910	*2910			*2290	*2290	7.70
24.6ft	lb									*6410	*6410			*5040	*5040	(25.3)
6.0m	kg									*3710	*3710			*2150	*2150	8.58
19.7ft	lb									*8180	*8180			*4750	*4750	(28.1)
4.5m	kg						*4150	*4150	*4000	*4000	*2650	*2650	*2120	*2120	9.13	
14.8ft	lb						*9150	*9150	*8830	*8830	*5840	*5840	*4670	*4670	(29.9)	
3.0m	kg			*9420	*9420	*6280	*6280	*5080	*5080	*4490	4130	*3680	3070	*2160	*2160	9.40
9.8ft	lb			*20760	*20760	*13850	*13850	*11200	*11200	*9900	9110	*8100	6770	*4670	*4670	(30.9)
1.5m	kg			*7690	*7690	*8210	*8210	*6080	5550	*5040	3970	*4120	2990	*2280	*2280	9.43
4.9ft	lb			*16960	*16960	*18100	*18100	*13400	12230	*11120	8750	*9080	6600	*5030	*5030	(30.9)
0.0m	kg			*7470	*7470	*9550	8150	*6900	5310	5350	3830	*3700	2930	*2500	*2500	9.22
0.0ft	lb			*16480	*16480	*21050	17970	*15200	11700	11800	8450	*8150	6470	*5510	*5510	(30.2)
-1.5m	kg	*5980	*5980	*9940	*9940	*10140	7960	*7360	5170	5270	3760			*2870	*2870	8.73
-4.9ft	lb	*13180	*13180	*21920	*21920	*22350	17550	*16220	11400	11620	8290			*6330	*6330	(28.7)
-3.0m	kg	*9160	*9160	*13930	*13930	*10010	7950	*7340	5150	5280	3770			*3550	3500	7.94
-9.8ft	lb	*20190	*20190	*30710	*30710	*22060	17530	*16170	11350	11650	8310			*7830	7720	(26.1)
-4.5m	kg	*13260	*13260	*13150	*13150	*9000	8110	*6510	5270					*5070	4530	6.72
-14.8ft	lb	*29230	*29230	*28990	*28990	*19830	17870	*14340	11610					*11180	9980	(22.0)

6. BUCKET SELECTION GUIDE

1) HX220 L

(1) General bucket

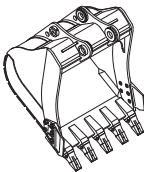
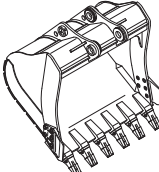
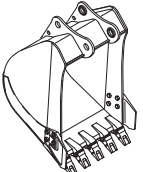
		
0.80, 0.92, 1.10, 1.20 m ³ SAE heaped bucket	1.34 m ³ SAE heaped bucket	★0.52 m ³ SAE heaped bucket

Capacity		Width		Weight	Recommendation				
					5.68 m (18' 8") boom				8.2m (26' 11") boom
SAE heaped	CECE heaped	Without side cutter	With side cutter		2.0 m arm (6' 7")	2.4 m arm (7' 10")	2.92 m arm (9' 7")	3.90 m arm (12' 10")	6.3 m arm (20' 8")
0.80 m ³ (1.05 yd ³)	0.70 m ³ (0.92 yd ³)	1070 mm (42.1")	1160 mm (45.7")	770 kg (1700 lb)	●	●	●	○	X
0.92 m ³ (1.20 yd ³)	0.80 m ³ (1.05 yd ³)	1190 mm (46.9")	1280 mm (50.4")	820 kg (1810 lb)	●	●	●	○	X
1.10 m ³ (1.44 yd ³)	0.96 m ³ (1.26 yd ³)	1375 mm (54.1")	1465 mm (57.7")	890 kg (1960 lb)	●	●	◐	○	X
1.20 m ³ (1.57 yd ³)	1.05 m ³ (1.37 yd ³)	1390 mm (54.7")	1480 mm (58.3")	920 kg (2030 lb)	●	◐	○	X	X
1.34 m ³ (1.75 yd ³)	1.17 m ³ (1.53 yd ³)	1525 mm (60.0")	1615 mm (63.6")	990 kg (2180 lb)	◐	◐	○	X	X
★0.52 m ³ (0.68 yd ³)	0.45 m ³ (0.59 yd ³)	945 mm (37.2")	1020 mm (40.2")	460 kg (1010 lb)	X	X	X	X	◐

★ : Long reach bucket/Amphibious bucket

● Applicable for materials with density of 2000 kgf/m³ (3370 lbf/yd³) or less

◐ Applicable for materials with density of 1600 kgf/m³ (2700 lbf/yd³) or less

○ Applicable for materials with density of 1100 kgf/m³ (1850 lbf/yd³) or less

X Not recommended

※ These recommendations are for general conditions and average use.

Work tools and ground conditions have effects on machine performance.

Select an optimum combination according to the working conditions and the type of work that is being done.

Consult your Hyundai dealer for information on selecting the correct boom–arm–bucket combination.

(2) Heavy duty and rock-heavy duty bucket

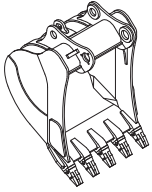
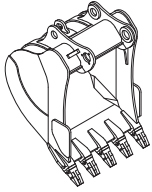
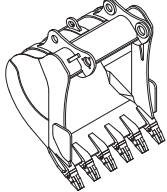
		
◆ 0.90, 1.05 m ³ SAE heaped bucket	◆ 0.87 m ³ SAE heaped bucket	◆ 1.20m ³ SAE heaped bucket

Capacity		Width		Weight	Recommendation			
					5.68 m (18' 8") boom			
SAE heaped	CECE heaped	Without side cutter	With side cutter		2.0 m arm (6' 7")	2.4 m arm (7' 10")	2.92 m arm (9' 7")	3.90 m arm (12' 10")
◆ 0.90 m ³ (1.18 yd ³)	0.79 m ³ (1.03 yd ³)	1210 mm (47.6")	-	880 kg (1940 lb)	●	●	●	○
◆ 1.05 m ³ (1.37 yd ³)	0.92 m ³ (1.20 yd ³)	1355 mm (53.3")	-	940 kg (2070 lb)	●	●	◐	○
◆ 0.87 m ³ (1.14 yd ³)	0.77 m ³ (1.01 yd ³)	1195 mm (47.0")	-	940 kg (2070 lb)	●	●	●	○
◆ 1.20 m ³ (1.57 yd ³)	1.05 m ³ (1.37 yd ³)	1520 mm (59.8")	-	1120 kg (2470 lb)	◐	○	X	X

◆ : Heavy duty bucket ◆ : Rock-Heavy duty bucket

● Applicable for materials with density of 2000 kg/m³ (3370 lbf/yd³) or less

◐ Applicable for materials with density of 1600 kg/m³ (2700 lbf/yd³) or less

○ Applicable for materials with density of 1100 kg/m³ (1850 lbf/yd³) or less

X Not recommended

2) HX220 L 2-PIECE BOOM

(1) General bucket

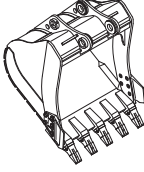
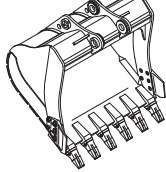
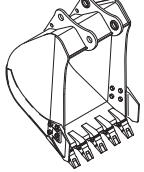
		
0.80, 0.92, 1.10, 1.20 m ³ SAE heaped bucket	1.34 m ³ SAE heaped bucket	★0.52 m ³ SAE heaped bucket

Capacity		Width		Weight	Recommendation		
					5.65 m (18' 6") 2-piece boom		
SAE heaped	CECE heaped	Without side cutter	With side cutter		2.0 m arm (6' 7")	2.4 m arm (7' 10")	2.92 m arm (9' 7")
0.80 m ³ (1.05 yd ³)	0.70 m ³ (0.92 yd ³)	1070 mm (42.1")	1160 mm (45.7")	770 kg (1700 lb)	●	●	◐
0.92 m ³ (1.20 yd ³)	0.80 m ³ (1.05 yd ³)	1190 mm (46.9")	1280 mm (50.4")	820 kg (1810 lb)	●	●	◐
1.10 m ³ (1.44 yd ³)	0.96 m ³ (1.26 yd ³)	1375 mm (54.1")	1465 mm (57.7")	890 kg (1960 lb)	●	◐	○
1.20 m ³ (1.57 yd ³)	1.05 m ³ (1.37 yd ³)	1390 mm (54.7")	1480 mm (58.3")	920 kg (2030 lb)	●	◐	X
1.34 m ³ (1.75 yd ³)	1.17 m ³ (1.53 yd ³)	1525 mm (60.0")	1615 mm (63.6")	990 kg (2180 lb)	◐	○	X
★0.52 m ³ (0.68 yd ³)	0.45 m ³ (0.59 yd ³)	945 mm (37.2")	1020 mm (40.2")	460 kg (1010 lb)	X	X	X

● Applicable for materials with density of 2000 kg/m³ (3370 lbf/yd³) or less

◐ Applicable for materials with density of 1600 kg/m³ (2700 lbf/yd³) or less

○ Applicable for materials with density of 1100 kg/m³ (1850 lbf/yd³) or less

X Not recommended

※ These recommendations are for general conditions and average use.

Work tools and ground conditions have effects on machine performance.

Select an optimum combination according to the working conditions and the type of work that is being done.

Consult your Hyundai dealer for information on selecting the correct boom–arm–bucket combination.

(2) Heavy duty and rock-heavy duty bucket

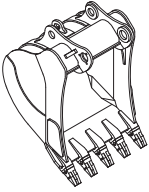
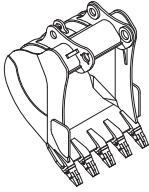
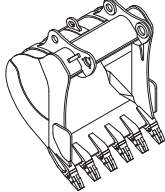
		
◆ 0.90, 1.05 m ³ SAE heaped bucket	◆ 0.87 m ³ SAE heaped bucket	◆ 1.20m ³ SAE heaped bucket

Capacity		Width		Weight	Recommendation		
					5.65 m (18' 6") 2-piece boom		
SAE heaped	CECE heaped	Without side cutter	With side cutter		2.0 m arm (6' 7")	2.4 m arm (7' 10")	2.92 m arm (9' 7")
◆ 0.90 m ³ (1.18 yd ³)	0.79 m ³ (1.03 yd ³)	1210 mm (47.6")	-	880 kg (1940 lb)	●	●	◐
◆ 1.05 m ³ (1.37 yd ³)	0.92 m ³ (1.20 yd ³)	1355 mm (53.3")	-	940 kg (2070 lb)	●	◐	○
◆ 0.87 m ³ (1.14 yd ³)	0.77 m ³ (1.01 yd ³)	1195 mm (47.0")	-	940 kg (2070 lb)	●	●	◐
◆ 1.20 m ³ (1.57 yd ³)	1.05 m ³ (1.37 yd ³)	1520 mm (59.8")	-	1120 kg (2470 lb)	◐	○	X

◆ : Heavy duty bucket ◆ : Rock-Heavy duty bucket

● Applicable for materials with density of 2000 kgf/m³ (3370 lbf/yd³) or less

◐ Applicable for materials with density of 1600 kgf/m³ (2700 lbf/yd³) or less

○ Applicable for materials with density of 1100 kgf/m³ (1850 lbf/yd³) or less

X Not recommended

7. UNDERCARRIAGE

1) TRACKS

X-leg type center frame is integrally welded with reinforced box-section track frames. The design includes dry tracks, lubricated rollers, idlers, sprockets, hydraulic track adjusters with shock absorbing springs and assembled track-type tractor shoes with triple grousers.

2) TYPES OF SHOES

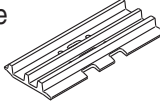
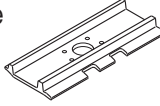
Model	Shapes		Grouser			
			Triple 	Double 		
HX220 L	Shoe width	mm (in)	600 (24)	700 (28)	800 (32)	900 (36)
	Operating weight	kg (lb)	22100 (48720)	22570 (49760)	22850 (50380)	23130 (50990)
	Ground pressure	kgf/cm ² (psi)	0.47 (6.68)	0.41 (5.83)	0.37 (5.26)	0.33 (4.69)
	Overall width	mm (ft-in)	2990 (9' 10")	3090 (10' 2")	3190 (10' 6")	3290 (10' 10")
HX220 L LONG REACH	Shoe width	mm (in)	-	-	800 (32)	-
	Operating weight	kg (lb)	-	-	24820 (54720)	-
	Ground pressure	kgf/cm ² (psi)	-	-	0.39 (5.55)	-
	Overall width	mm (ft-in)	-	-	3190 (10' 6")	-
HX220 L HIGH WALKER	Shoe width	mm (in)	600 (24)	700 (28)	800 (32)	710 (28)*
	Operating weight	kg (lb)	23560 (51940)	24030 (52980)	24310 (53590)	24040 (53000)
	Ground pressure	kgf/cm ² (psi)	0.50 (7.11)	0.44 (6.26)	0.39 (5.55)	0.43 (6.11)
	Overall width	mm (ft-in)	3395 (11' 2")	3495 (11' 6")	3595 (11' 10")	3505 (11' 6")
HX220 L 2-PIECE BOOM	Shoe width	mm (in)	600 (24)	700 (28)	800 (32)	900 (36)
	Operating weight	kg (lb)	22100 (48720)	22570 (49760)	22850 (50380)	23130 (50990)
	Ground pressure	kgf/cm ² (psi)	0.47 (6.68)	0.41 (5.83)	0.37 (5.26)	0.33 (4.69)
	Overall width	mm (ft-in)	2990 (9' 10")	3090 (10' 2")	3190 (10' 6")	3290 (10' 10")

* : Double grouser

3) NUMBER OF ROLLERS AND SHOES ON EACH SIDE

Item	Quantity
Carrier rollers	2 EA
Track rollers	9 EA
Track shoes	49 EA

4) SELECTION OF TRACK SHOE

Suitable track shoes should be selected according to operating conditions.

Method of selecting shoes

Confirm the category from the list of applications in **table 2**, then use **table 1** to select the shoe. Wide shoes (categories B and C) have limitations on applications. Before using wide shoes, check the precautions, then investigate and study the operating conditions to confirm if these shoes are suitable.

Select the narrowest shoe possible to meet the required flotation and ground pressure. Application of wider shoes than recommendations will cause unexpected problem such as bending of shoes, crack of link, breakage of pin, loosening of shoe bolts and the other various problems.

※ **Table 1**

Track shoe	Specification	Category
600 mm triple grouser	Standard	A
700 mm triple grouser	Option	B
710 mm double grouser ★1	Option	B
800 mm triple grouser	Option	C
800 mm triple grouser (long reach)	Standard	C
900 mm triple grouser	Option	C

★1 : HIGH WALKER ONLY

※ **Table 2**

Category	Applications	Precautions
A	Rocky ground, river beds, normal soil	<ul style="list-style-type: none"> Travel at low speed on rough ground with large obstacles such as boulders or fallen trees or a wide range of general civil engineering work.
B	Normal soil, soft ground	<ul style="list-style-type: none"> These shoes cannot be used on rough ground with large obstacles such as boulders or fallen trees Travel at high speed only on flat ground Travel slowly at low speed if it is impossible to avoid going over obstacles
C	Extremely soft ground (swampy ground)	<ul style="list-style-type: none"> Use the shoes only in the conditions that the machine sinks and it is impossible to use the shoes of category A or B These shoes cannot be used on rough ground with large obstacles such as boulders or fallen trees Travel at high speed only on flat ground Travel slowly at low speed if it is impossible to avoid going over obstacles

8. SPECIFICATIONS FOR MAJOR COMPONENTS

1) ENGINE

Item	Specification
Model	Cummins QSB6.7
Type	4-cycle turbocharged, charger air cooled diesel engine
Cooling method	Water cooling
Number of cylinders and arrangement	6 cylinders, in-line
Firing order	1-5-3-6-2-4
Combustion chamber type	Direct injection type
Cylinder bore × stroke	107 × 124 mm (4.2" × 4.9")
Piston displacement	6700 cc (409cu in)
Compression ratio	17.3 : 1
Rated net horse power (SAE J1349)	173 Hp at 1950 rpm (129 kW at 1950 rpm)
Rated gross horse power (SAE J1995)	182.6 Hp at 1950 rpm (136 kW at 1950 rpm)
Maximum torque at 1500 rpm	85.7 kgf · m (620 lbf · ft)
Engine oil quantity	23.1 ℓ (6.1 U.S. gal)
Wet weight	520 kg (1146 lb)
High idling speed	1900 ± 50 rpm
Low idling speed	850 ± 100 rpm
Rated fuel consumption	158.5 g/Hp · hr at 1950 rpm
Starting motor	Nippon denso (24 V-4.8 kW)
Alternator	Delco Remy (24 V-95 A)
Battery	2 × 12 V × 100 Ah

2) MAIN PUMP

Item	Specification
Type	Variable displacement tandem axis piston pumps
Capacity	2 × 130 cc/rev
Maximum pressure	350 kgf/cm ² (4980 psi) [380 kgf/cm ² (5400 psi)]
Rated oil flow	2 × 241 ℓ /min (63.7 U.S. gpm/ 53.0 U.K. gpm)
Rated speed	1850 rpm

[] : Power boost

3) GEAR PUMP

Item	Specification
Type	Fixed displacement gear pump single stage
Capacity	10 cc/rev
Maximum pressure	45 kgf/cm ² (640 psi)
Rated oil flow	18.5 ℓ /min (4.9 U.S. gpm/4.1 U.K. gpm)

4) MAIN CONTROL VALVE

Item	Specification	
	HX220 L	HX220 L Long reach
Type	9 spools two-block	
Operating method	Hydraulic pilot system	
Main relief valve pressure	350 kgf/cm ² (4980 psi) [380 kgf/cm ² (5400 psi)] *1 350 kgf/cm ² (4980 psi) [Not applied power boost]	
Port relief valve pressure	Boom	400 kgf/cm ² (5690 psi)
	Arm	400 kgf/cm ² (5690 psi) 300 kgf/cm ² (4270 psi)
	Bucket	400 kgf/cm ² (5690 psi) 280 kgf/cm ² (3980 psi)

[] : Power boost *1 : Long reach only

5) SWING MOTOR

Item	Specification
Type	Two fixed displacement axial piston motor
Capacity	142.8 cc/rev
Relief pressure	265 kgf/cm ² (3770 psi)
Braking system	Automatic, spring applied hydraulic released
Braking torque	58 kgf/cm ² (420 psi)
Brake release pressure	21.3~35.6 kgf · m (154~257 lbf · ft)
Reduction gear type	2 - stage planetary

6) TRAVEL MOTOR

Item	Specification
Type	Variable displacement axial piston motor
Relief pressure	350 kgf/cm ² (4980 psi)
Reduction gear type	2-stage planetary
Braking system	Automatic, spring applied hydraulic released
Brake release pressure	15.2 kgf/cm ² (216 psi)
Braking torque	65.4 kgf · m (473 lbf · ft)

7) REMOTE CONTROL VALVE

Item		Specification
Type		Pressure reducing type
Operating pressure	Minimum	6.5 kgf/cm ² (92 psi)
	Maximum	25 kgf/cm ² (356 psi)
Single operation stroke	Lever	90 mm (3.5 in)
	Pedal	130 mm (4.4 in)

8) CYLINDER

Item		Specification
Boom cylinder	Bore dia × Stroke	∅ 120 × 1290 mm
	Cushion	Extend only
Arm cylinder	Bore dia × Stroke	∅ 140 × 1510 mm # ∅ 140 × 1460 mm
	Cushion	Extend and retract
Bucket cylinder	Bore dia × Stroke	∅ 120 × 1055 mm # ∅ 100 × 870 mm
	Cushion	Extend only
Adjust boom cylinder (opt)	Bore dia × Stroke	∅ 160 × 1060 mm
	Cushion	Extend only

※ Discoloration of cylinder rod can occur when the friction reduction additive of lubrication oil spreads on the rod surface.

※ Discoloration does not cause any harmful effect on the cylinder performance.

: LONG REACH

9) SHOE

Item		Width	Ground pressure	Link quantity	Overall width
HX220 L	Standard	600 mm (24")	0.47 kgf/cm ² (6.68 psi)	49	2990 mm (9' 10")
	Option	700 mm (28")	0.41 kgf/cm ² (5.83 psi)	49	3090 mm (10' 2")
		800 mm (32")	0.37 kgf/cm ² (5.26 psi)	49	3190 mm (10' 6")
		900 mm (36")	0.33 kgf/cm ² (4.69 psi)	49	3290 mm (10' 10")
HX220 L LONG REACH	Standard	800 mm (32")	0.39 kgf/cm ² (5.55 psi)	49	3190 mm (10' 6")
HX220 L HIGH WALKER	Standard	600 mm (24")	0.50 kgf/cm ² (7.11 psi)	49	3395 mm (11' 2")
	Option	700 mm (28")	0.44 kgf/cm ² (6.26 psi)	49	3495 mm (11' 6")
		800 mm (32")	0.39 kgf/cm ² (5.55 psi)	49	3595 mm (11' 10")
		※ 710 mm (28")	0.43 kgf/cm ² (6.11 psi)	49	3505 mm (11' 6")

※ : Double grouser

10) BUCKET

Item	Capacity		Tooth quantity	Width	
	SAE heaped	CECE heaped		Without side cutter	With side cutter
HX220 L	0.80 m ³ (1.05 yd ³)	0.70 m ³ (0.92 yd ³)	5	1070 mm (42.1")	1160 mm (45.7")
	0.92 m ³ (1.20 yd ³)	0.80 m ³ (1.05 yd ³)	5	1190 mm (46.9")	1280 mm (50.4")
	1.10 m ³ (1.44 yd ³)	0.96 m ³ (1.26 yd ³)	5	1375 mm (54.1")	1465 mm (57.7")
	1.20 m ³ (1.57 yd ³)	1.05 m ³ (1.37 yd ³)	5	1390 mm (54.7")	1480 mm (58.3")
	1.34 m ³ (1.75 yd ³)	1.17 m ³ (1.53 yd ³)	6	1525 mm (60.0")	1615 mm (63.6")
	★0.52 m ³ (0.68 yd ³)	0.45 m ³ (0.59 yd ³)	5	945 mm (37.2")	1020 mm (40.2")
	◆0.90 m ³ (1.18 yd ³)	0.79 m ³ (1.03 yd ³)	5	1210 mm (47.6")	—
	◆1.05 m ³ (1.37 yd ³)	0.92 m ³ (1.20 yd ³)	5	1355 mm (53.3")	—
	⊙0.87 m ³ (1.14 yd ³)	0.77 m ³ (1.01 yd ³)	5	1195 mm (47.0")	—
	⊙1.20 m ³ (1.57 yd ³)	1.05 m ³ (1.37 yd ³)	6	1520 mm (59.8")	—

★ : Long reach bucket

◆ : Heavy duty bucket

⊙ : Rock-heavy duty bucket

9. RECOMMENDED OILS

HYUNDAI genuine lubricating oils have been developed to offer the best performance and service life for your equipment. These oils have been tested according to the specifications of HYUNDAI and, therefore, will meet the highest safety and quality requirements.

We recommend that you use only HYUNDAI genuine lubricating oils and grease officially approved by HYUNDAI.

Service point	Kind of fluid	Capacity ℓ (U.S. gal)	Ambient temperature °C (°F)						
			-50 (-58)	-30 (-22)	-20 (-4)	-10 (14)	0 (32)	10 (50)	20 (68)
Engine oil pan	Engine oil	24.4 (6.4)	★SAE 5W-40						
			SAE 30						
			SAE 10W						
			SAE 10W-30						
			SAE 15W-40						
DEF/ AdBlue® tank	Mixture of urea and deionized water	27.0 (7.1)	ISO 22241, High-purity urea + deionized water (32.5:67.5)						
Swing drive	Gear oil	6.2 (1.2)	★SAE 75W-90						
Final drive		4.5×2 (1.2×2)	SAE 80W-90						
Hydraulic tank	Hydraulic oil	Tank : 160 (42.3) System : 275★ (72.6)	★ISO VG 15						
			ISO VG 32						
			ISO VG 46, HBHO VG 46★ ³						
			ISO VG 68						
Fuel tank	Diesel fuel★ ¹	400 (106)	★ASTM D975 NO.1						
			ASTM D975 NO.2						
Fitting (grease nipple)	Grease	As required	★NLGI NO.1						
			NLGI NO.2						
Radiator (reservoir tank)	Mixture of antifreeze and soft water★ ²	40 (10.6)	Ethylene glycol base permanent type (50 : 50)						
			★Ethylene glycol base permanent type (60 : 40)						

SAE : Society of Automotive Engineers

API : American Petroleum Institute

ISO : International Organization for Standardization

NLGI : National Lubricating Grease Institute

ASTM : American Society of Testing and Material

DEF : Diesel Exhaust Fluid, DEF compatible with AdBlue®

★ : Cold region (Russia, CIS, Mongolia)

★¹ : Ultra low sulfur diesel
- sulfur content ≤ 15 ppm

★² : Soft water
City water or distilled water

★³ : Hyundai Bio Hydraulic Oil

※ Using any lubricating oils other than HYUNDAI genuine products may lead to a deterioration of performance and cause damage to major components.

※ Do not mix HYUNDAI genuine oil with any other lubricating oil as it may result in damage to the systems of major components.

※ Do not use any engine oil other than that specified above, as it may clog the diesel particulate filter(DPF).

※ For HYUNDAI genuine lubricating oils and grease for use in regions with extremely low temperatures, please contact HYUNDAI dealers.