

SECTION 4 ELECTRICAL SYSTEM

Group 1 Component Location	4-1
Group 2 Electrical Circuit	4-3
Group 3 Electrical Component Specification	4-23
Group 4 Connectors	4-32

SECTION 4 ELECTRICAL SYSTEM

GROUP 1 COMPONENT LOCATION

1. LOCATION 1

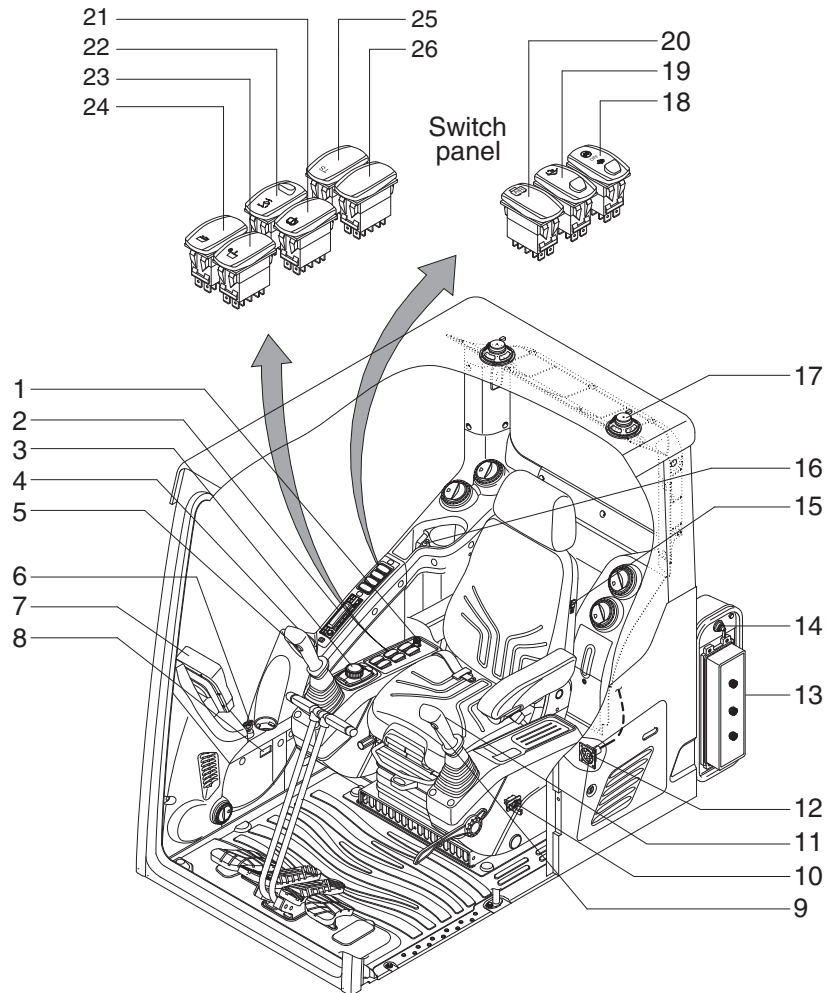

220F4EL101

- | | | |
|----------------------------|---------------------------------|--------------------------------|
| 1 Cigar lighter | 10 Emergency engine stop switch | 19 Quick clamp switch |
| 2 Radio & USB player | 11 One touch decel switch | 20 Air compressor switch |
| 3 Haptic controller | 12 RS232 & J1939 service socket | 21 Lower wiper & washer switch |
| 4 Horn switch | 13 Fuse & relay box | 22 Boom floating switch |
| 5 Breaker operation switch | 14 Master switch | 23 Swing lock switch |
| 6 Starting switch | 15 Seat heater switch | 24 Swing fine switch |
| 7 Cluster | 16 Power socket | 25 Travel straight switch |
| 8 Service meter | 17 Speaker | 26 Option attach switch |
| 9 Power max switch | 18 SCR system cleaning switch | |

2. LOCATION 2

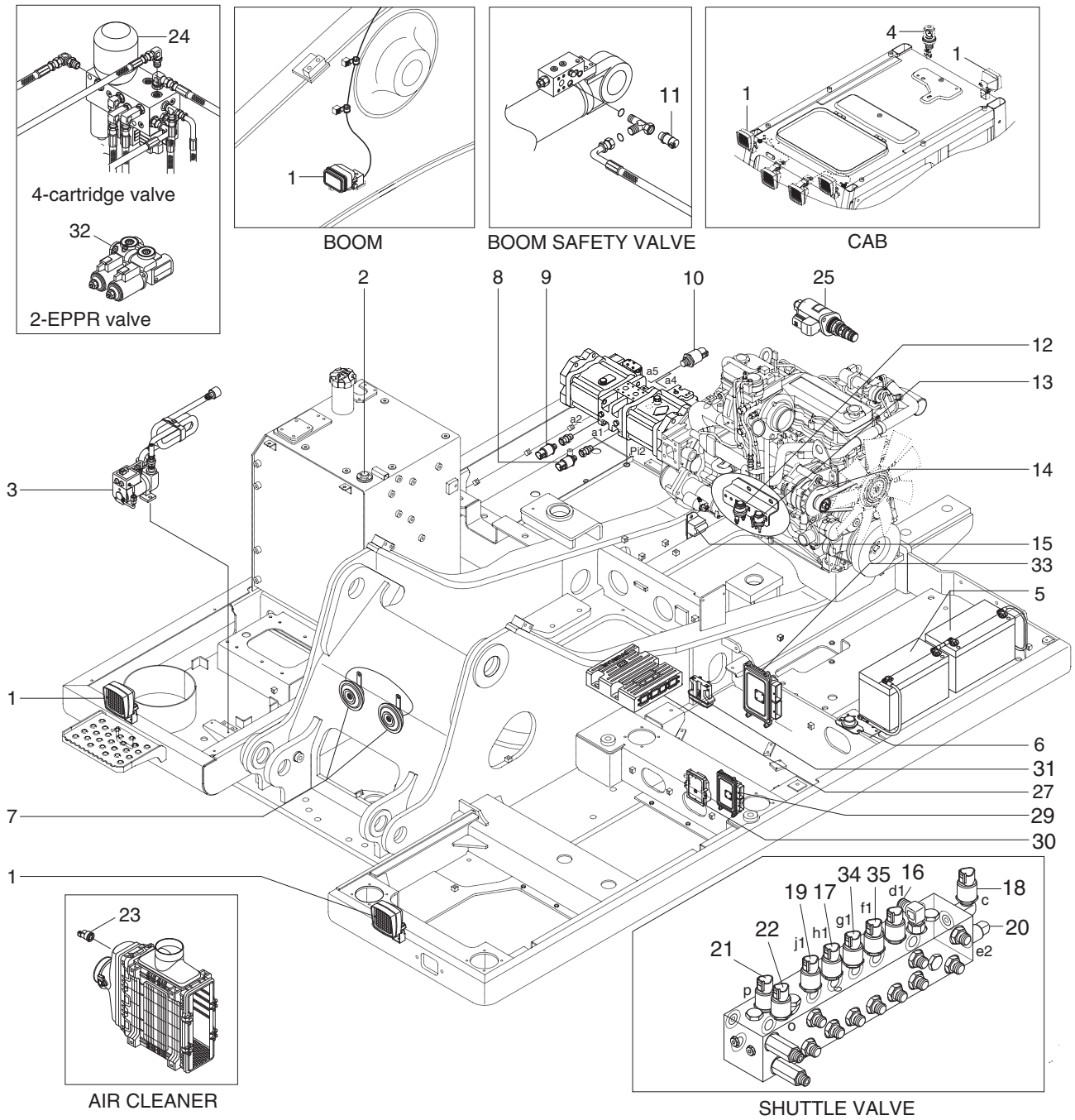

220F4EL102

- | | | |
|-----------------------------|------------------------------|-------------------------------|
| 1 Lamp | 12 Start relay | 23 Air cleaner sensor |
| 2 Fuel sender | 13 Heater relay | 24 4-cartridge valve |
| 3 Fuel filler pump | 14 Alternator | 25 Pump EPPR valve |
| 4 Beacon lamp | 15 Travel alarm buzzer | 27 United MCU |
| 5 Battery | 16 Arm out pressure sensor | 29 AAVM controller |
| 6 Battery relay | 17 Boom up pressure sensor | 30 RDU |
| 7 Horn | 18 Swing pressure sensor | 31 PVG32 controller |
| 8 P1 pressure sensor | 19 Boom down pressure sensor | 32 2-EPPR valve |
| 9 P2 pressure sensor | 20 Arm in pressure sensor | 33 EPCU |
| 10 EPPR pressure sensor | 21 RH travel pressure sensor | 34 Bucket out pressure sensor |
| 11 Overload pressure sensor | 22 LH travel pressure sensor | 35 Bucket in pressure sensor |

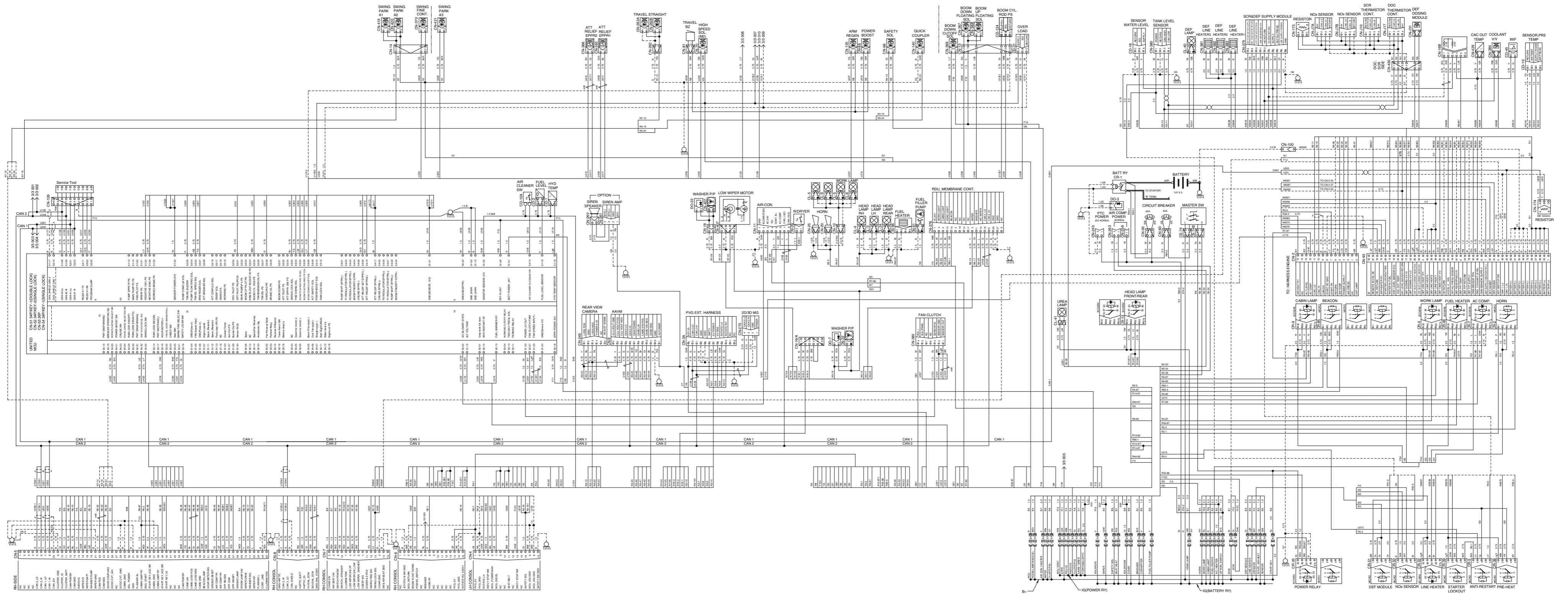

ELECTRICAL CIRCUIT (2/3)

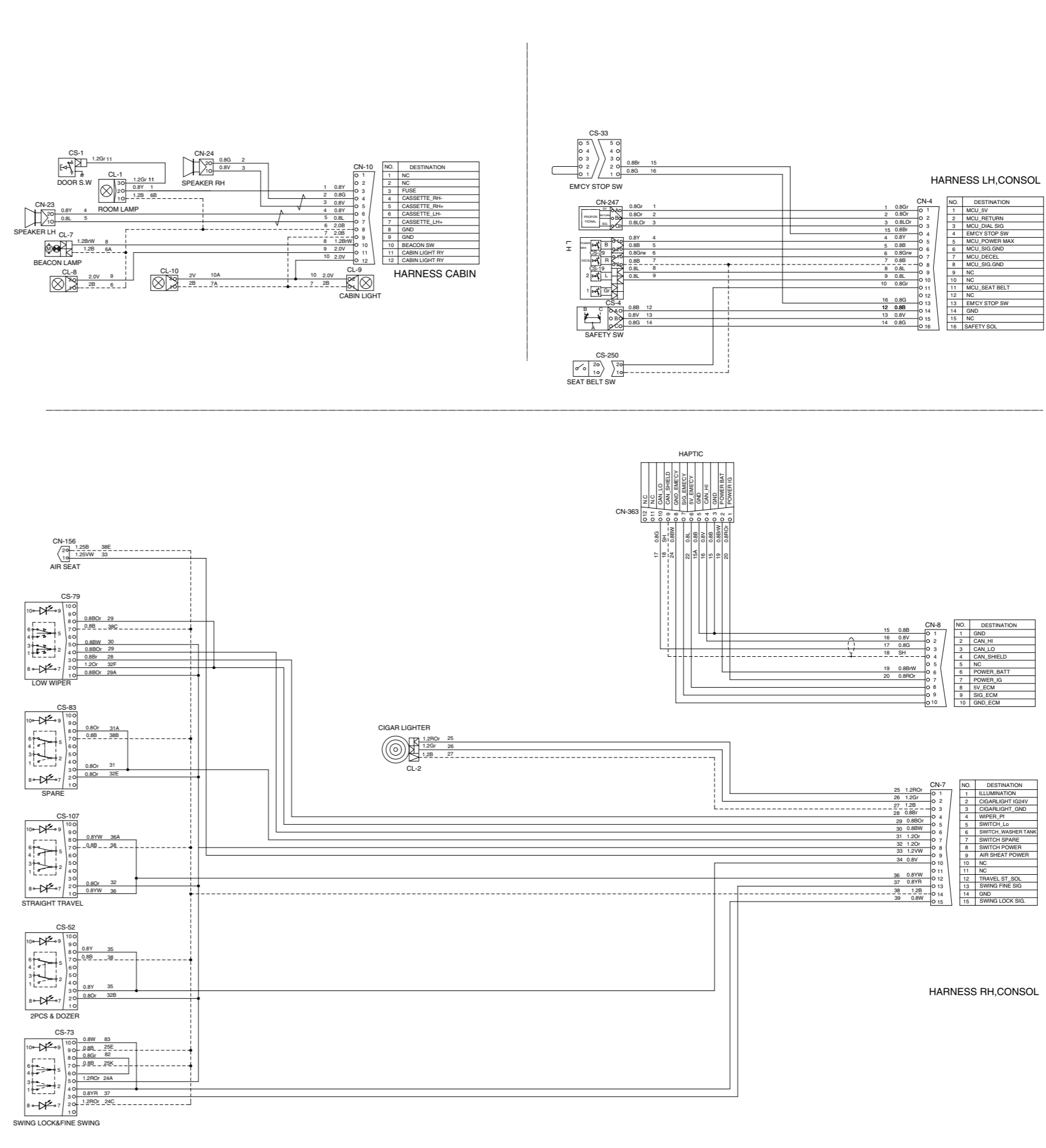
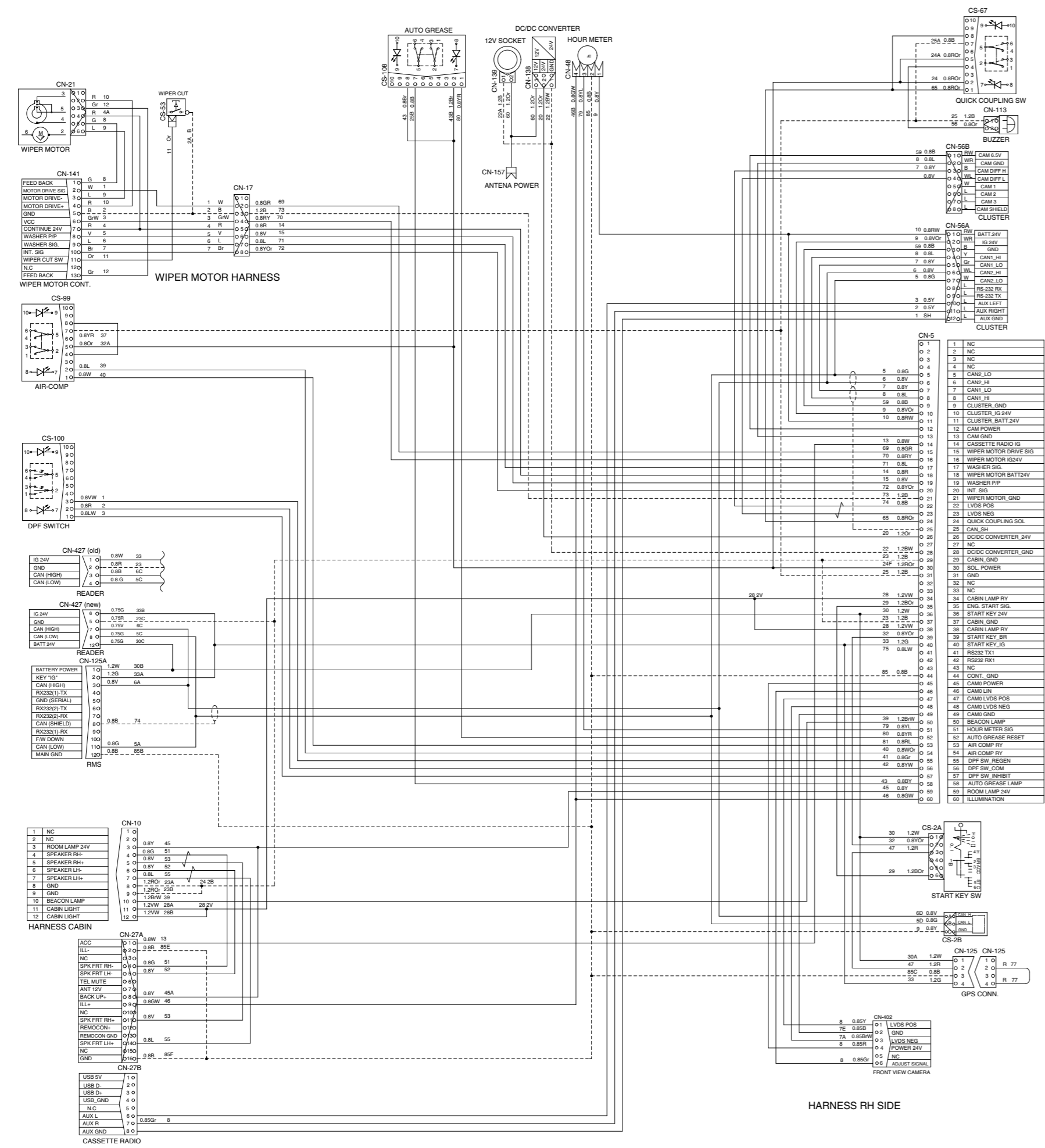

ELECTRICAL CIRCUIT (3/3)

- MACHINE SERIAL NO. : #1471

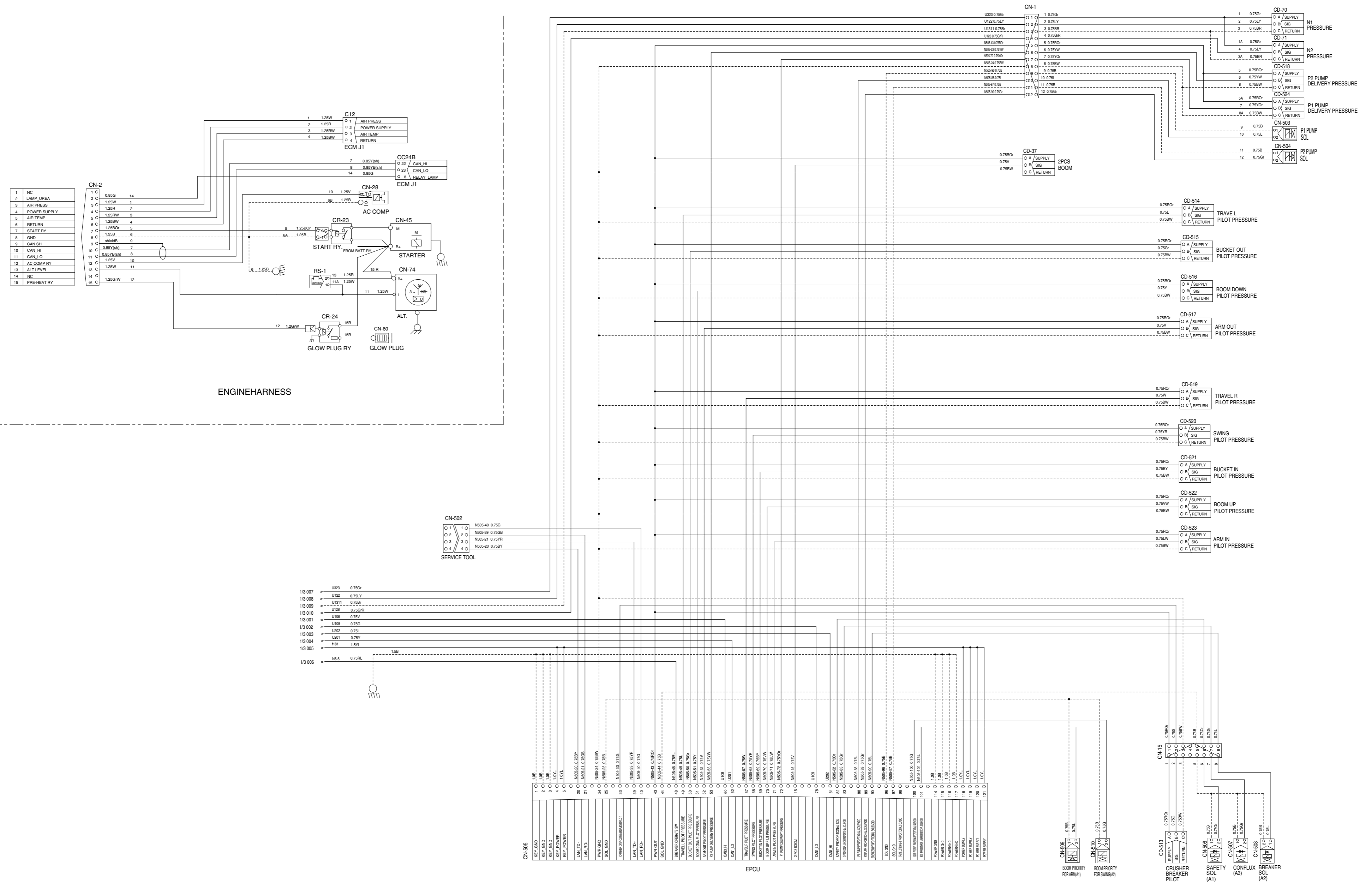

MEMORANDUM

1. POWER CIRCUIT

The negative terminal of battery is grounded to the machine chassis.

When the start switch is in the OFF position, the current flows from the positive battery terminal as shown below.

1) OPERATING FLOW

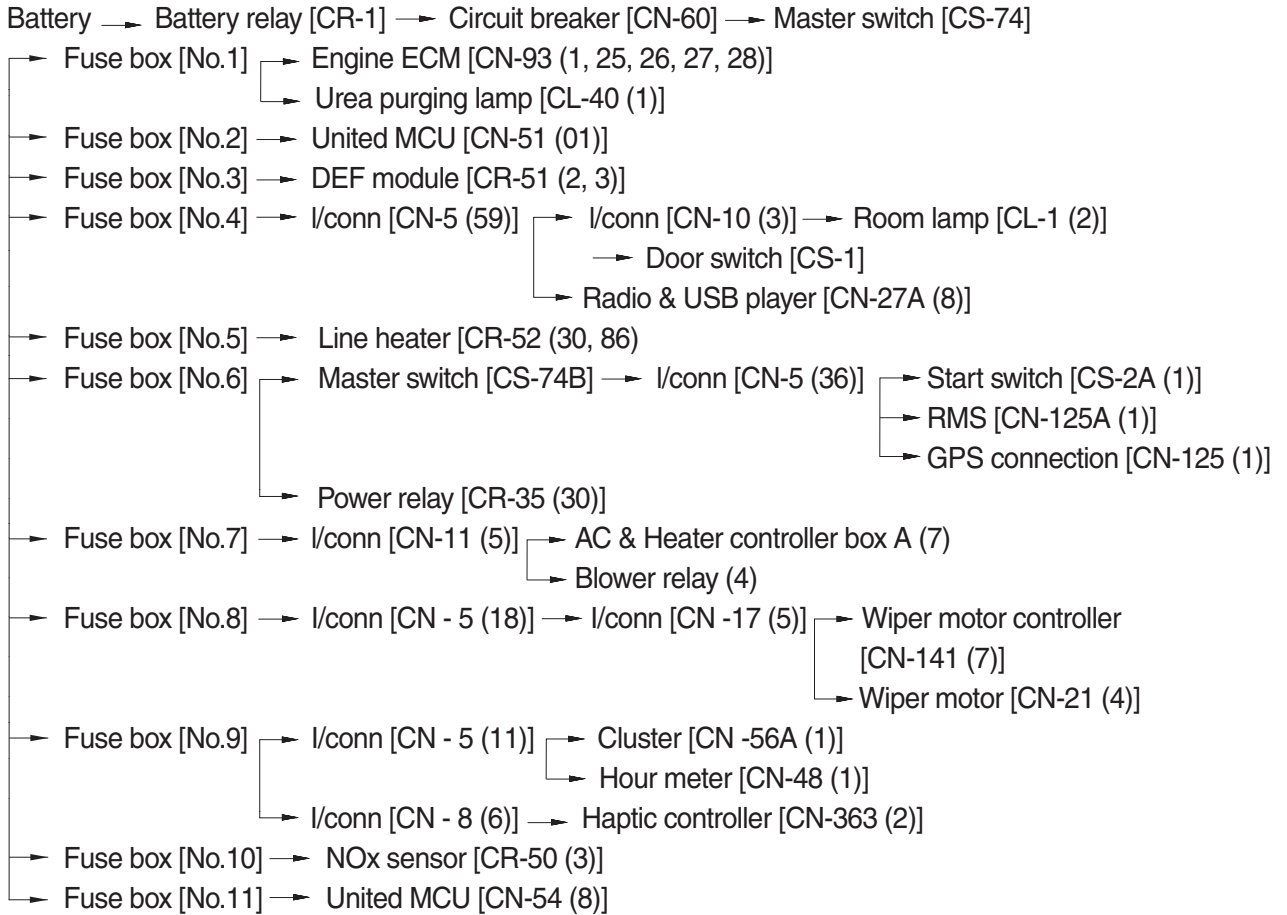

※ I/conn : Intermediate connector

2) CHECK POINT

Engine	Start switch	Check point	Voltage
STOP	OFF	① - GND (battery 1EA)	10~12.5V
		② - GND (battery 2EA)	20~25V
		③ - GND (battery relay)	20~25V
		④ - GND (circuit breaker)	20~25V

※ GND : Ground

POWER CIRCUIT

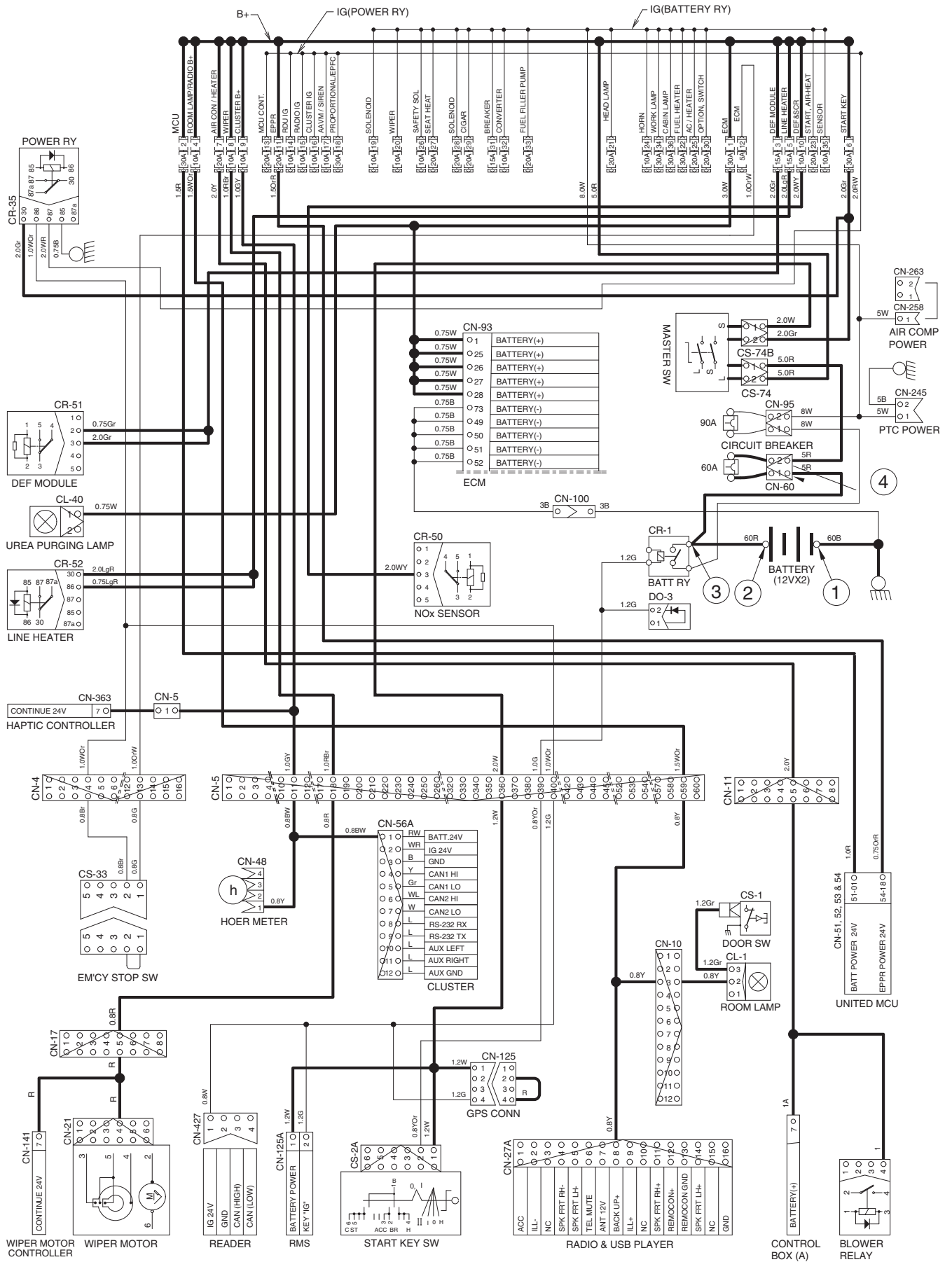

220F4EL105

3. CHARGING CIRCUIT

When the starter is activated and the engine is started, the operator releases the start switch to the ON position.

Charging current generated by operating alternator flows into the battery through the battery relay [CR-1].

The current also flows from alternator to each electrical component and controller through the fuse box.

1) OPERATING FLOW

(1) Warning flow

Alternator "L" terminal → I/conn [CN-2 (13)] → United MCU alternator voltage [CN-51 (15)]
 → Cluster charging warning lamp (Via CAN interface)

(2) Charging flow

Alternator "B+" terminal → Starter [CN-45 (B+)] → Battery relay (M8)
 → Battery (+) terminal
 → Circuit breaker [CN-60] → Master switch [CS-74] → Fuse box [B+]
 → Circuit breaker [CN-95] → Fuse box [IG, battery] → Power relay [CR-35 (30→87)]
 → Fuse box [IG, power]

2) CHECK POINT

Engine	Start switch	Check point	Voltage
OPERATING	ON	① - GND (battery voltage) ② - GND (battery relay) ③ - GND (alternator B ⁺ terminal) ④ - GND (alternator L terminal) ⑤ - GND (United MCU)	20~25V

※ GND : Ground

CHARGING CIRCUIT

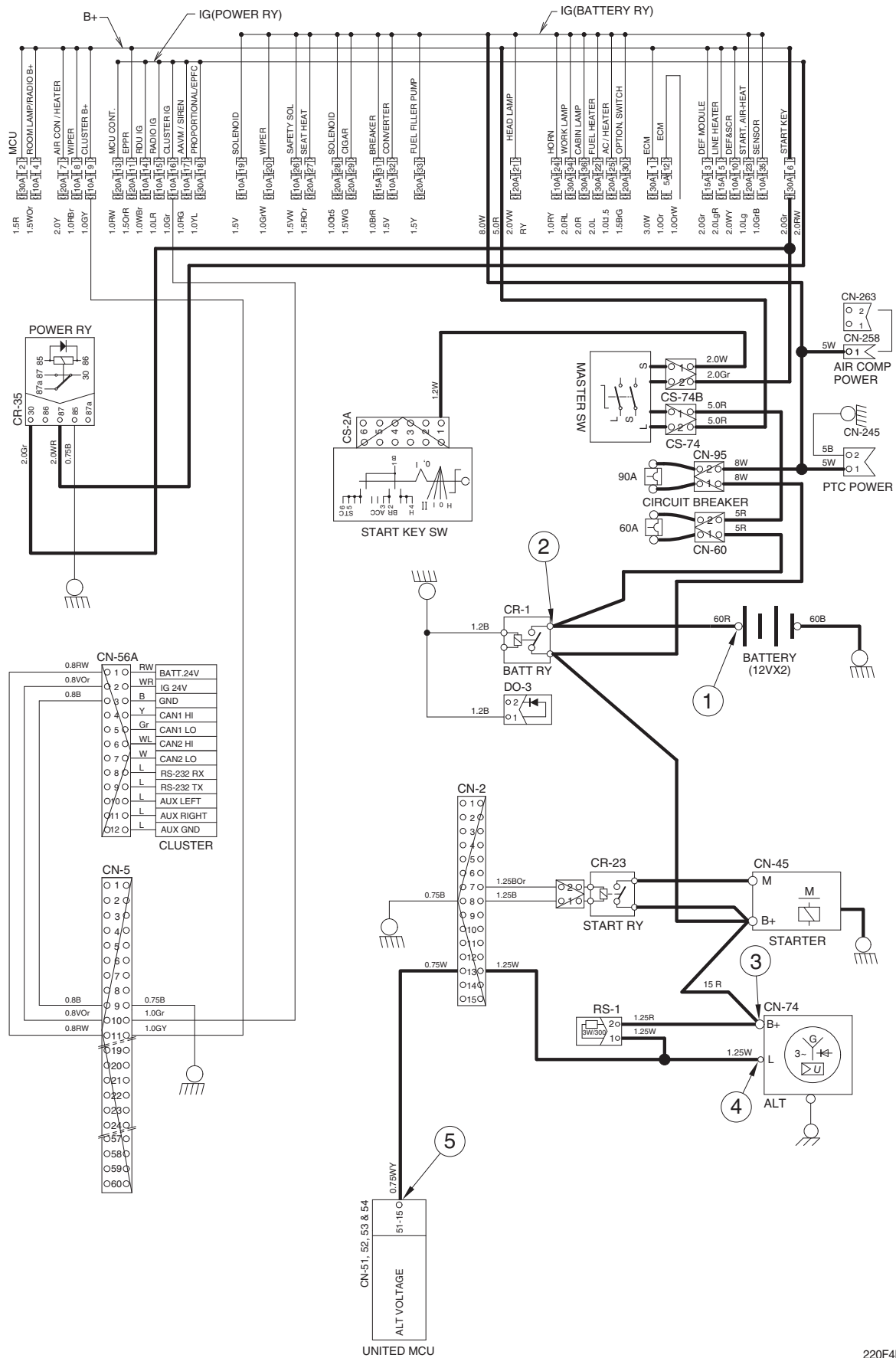

220F4EL107

4. HEAD AND WORK LIGHT CIRCUIT

1) OPERATING FLOW

Fuse box (No.21) → Head light relay [CR-13 (30, 86)]

Fuse box (No.34) → Work light relay [CR-4 (30, 86)]

Fuse box (No.14) → RDU membrane controller [CR-376 (1)]

(1) Head light switch ON

Head light switch ON [CN-376 (13)] → Head light relay [CR-13 (85) → (87)]

→ Head light ON [CL-3 (1), CL-4 (1), CL-24 (1)]

→ I/conn [CN-7 (1)] → Cigar lighter [CL-2]

→ I/conn [CN-5 (60)] → Radio & USB player illumination ON [CN-27A (9)]

→ Hour meter illumination ON [CN-48 (4)]

(2) Work light switch ON

Work light switch ON [CN-376 (4)] → Work light relay [CR-4 (85) → (87)]

→ I/conn [CN-12 (1)] → Work light ON [CL-5 (1), CL-6 (1)]

2) CHECK POINT

Engine	Start switch	Check point	Voltage
STOP	ON	① - GND (fuse box) ② - GND (switch power output) ③ - GND (head light relay) ④ - GND (head light) ⑤ - GND (fuse box) ⑥ - GND (switch power input) ⑦ - GND (work light relay) ⑧ - GND (work light)	20~25V

※ GND : Ground

HEAD AND WORK LIGHT CIRCUIT

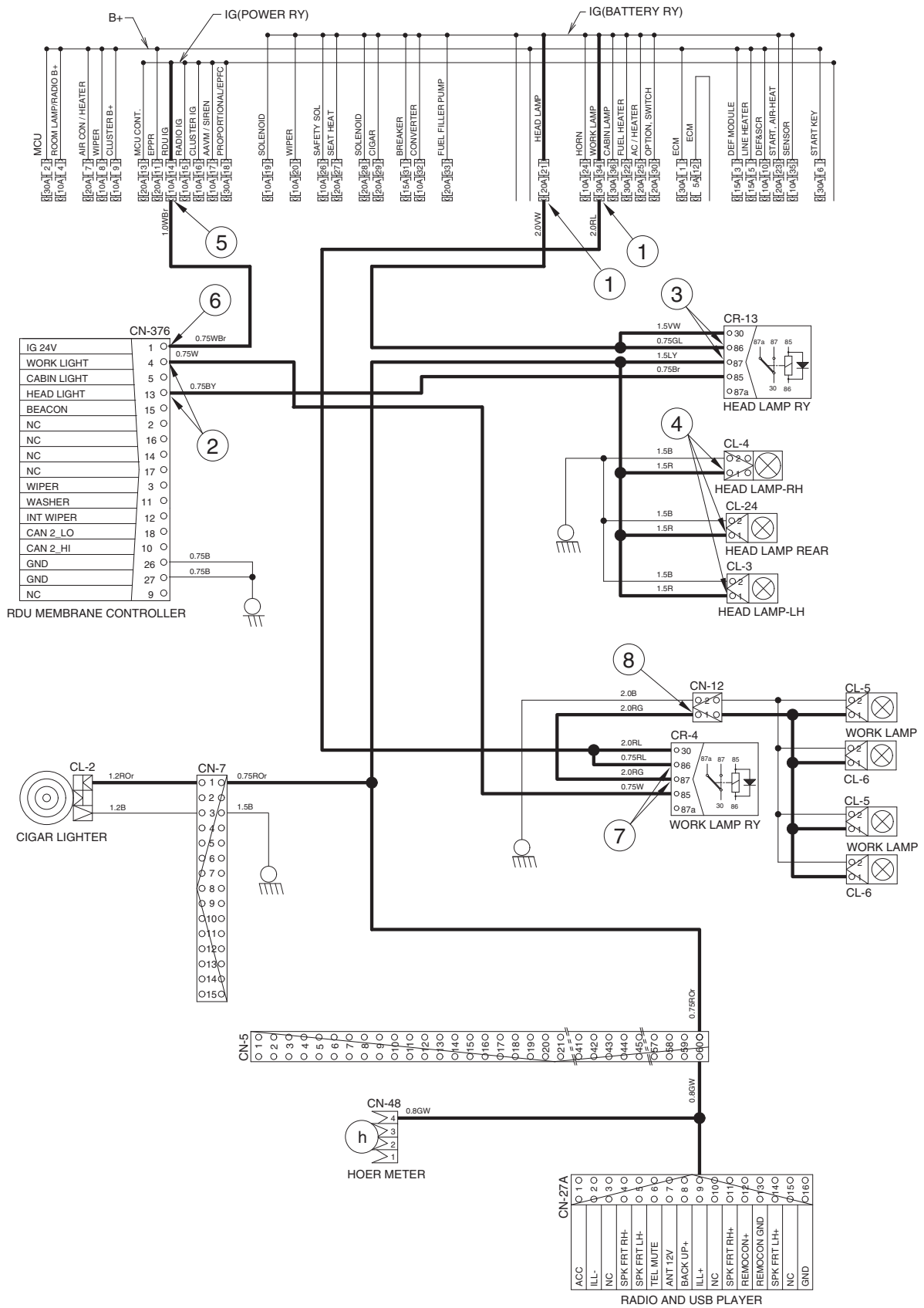

5. BEACON LAMP AND CAB LIGHT CIRCUIT

1) OPERATING FLOW

Fuse box (No.30) → Beacon lamp relay [CR-85 (2, 3)]

Fuse box (No.36) → Cab light relay [CR-9 (30, 86)]

Fuse box (No.14) → RDU membrane controller [CN-376 (1)]

(1) Beacon lamp switch ON

Beacon lamp switch ON [CN-376 (15)] → Beacon lamp relay [CR-85 (1)→ (5)]

→ I/conn [CN-5 (50)] → I/conn [CN-10 (10)] → Beacon lamp ON [CL-7]

(2) Cab light switch ON

Cab light switch ON [CN-376 (5)] → Cab lamp relay [CR-9 (85)→ (87)]

→ I/conn [CN-5 (34, 38)] → I/conn [CN-10 (11)] → Cab light ON [CL-8 (2)]

→ I/conn [CN-10 (12)] → Cab light ON [CL-9 (2), CL-10 (2)]

2) CHECK POINT

Engine	Start switch	Check point	Voltage
STOP	ON	① - GND (fuse box) ② - GND (beacon lamp relay) ③ - GND (switch power output) ④ - GND (beacon lamp) ⑤ - GND (fuse box) ⑥ - GND (cabin light relay) ⑦ - GND (switch power input) ⑧ - GND (cab light)	20~25V

※ GND : Ground

BEACON LAMP AND CAB LIGHT CIRCUIT

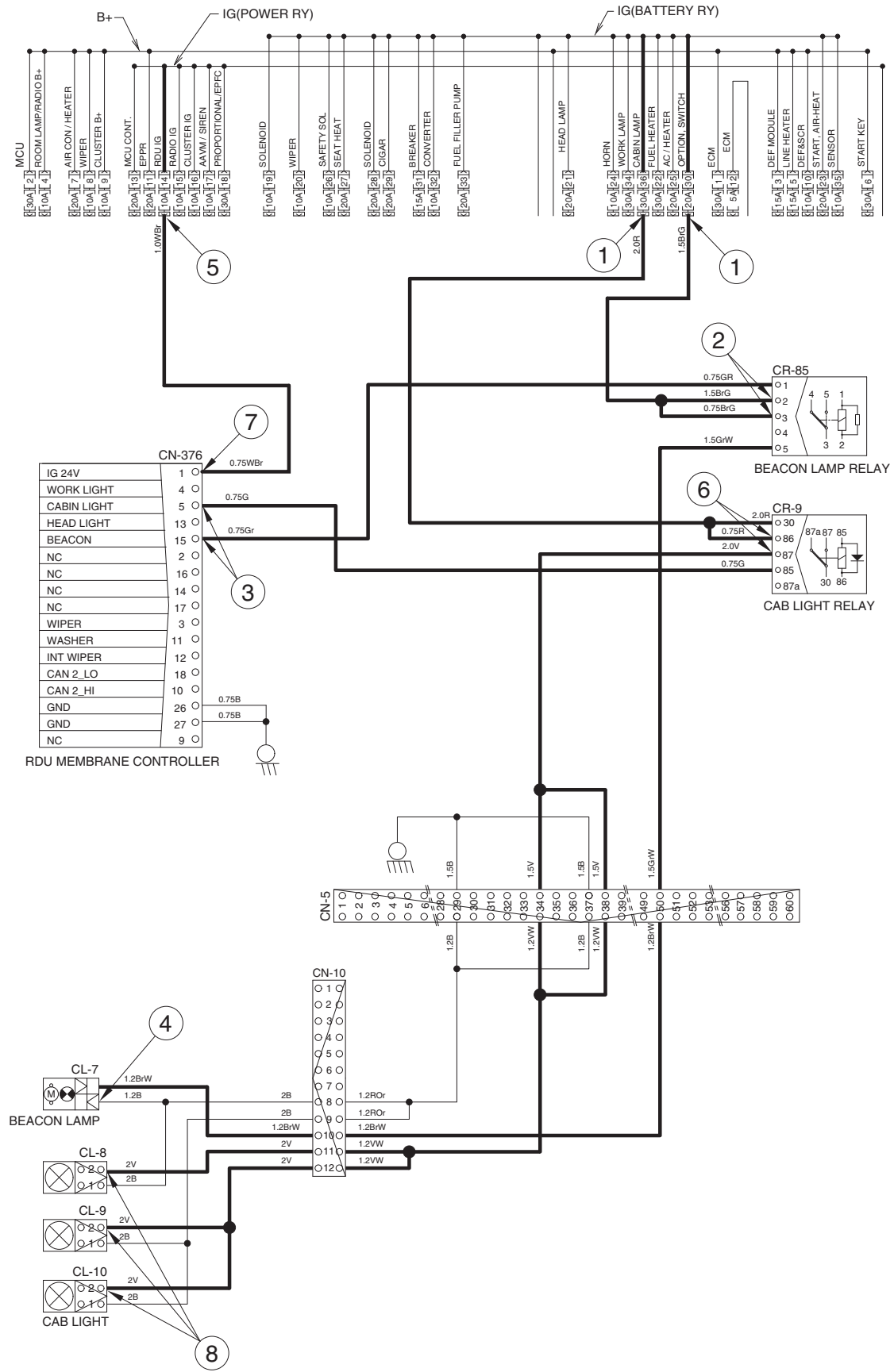

6. WIPER AND WASHER CIRCUIT

1) OPERATING FLOW

(1) Key switch ON

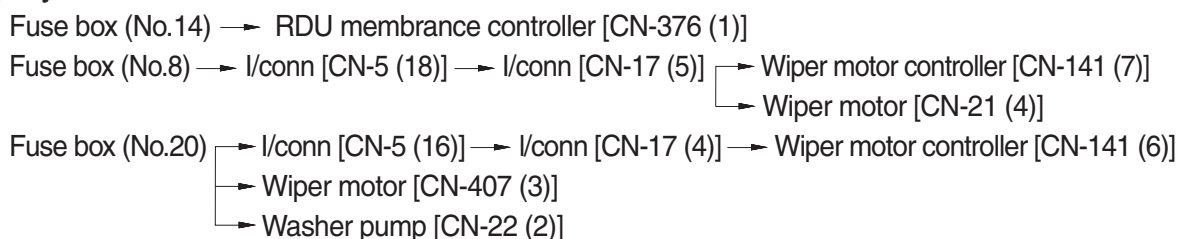

(2) Wiper switch ON (Intermittent)

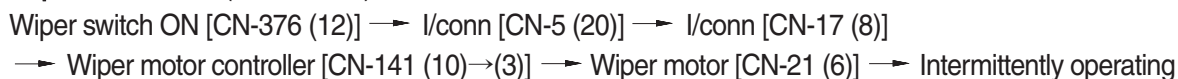

(3) Wiper switch ON (continual)

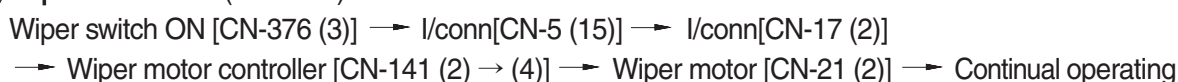

(4) Washer switch ON

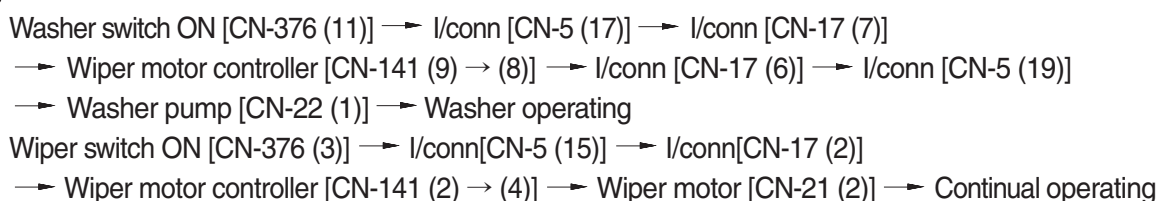

(5) Auto parking (when switch OFF)



2) OPERATING FLOW (LOW WIPER)

(1) Key switch ON

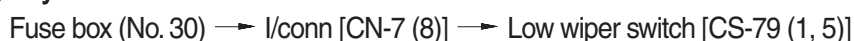

(2) Wiper switch ON (1st)

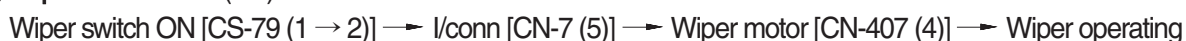

(3) Wiper switch ON (2nd)

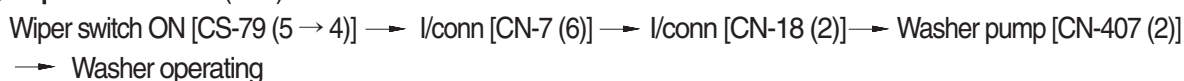

3) CHECK POINT

Engine	Start switch	Check point	Voltage
STOP	ON	① - GND (fuse box)	20~25V
		② - GND (switch power input)	
		③ - GND (wiper power input)	
		④ - GND (switch power output)	
		⑤ - GND (switch power output)	0 ~ 5V
		⑥ - GND (wiper power switch input)	
		⑦ - GND (wiper power output)	
		⑧ - GND (wiper motor)	
			0 or 24V

※ GND : Ground

WIPER AND WASHER CIRCUIT

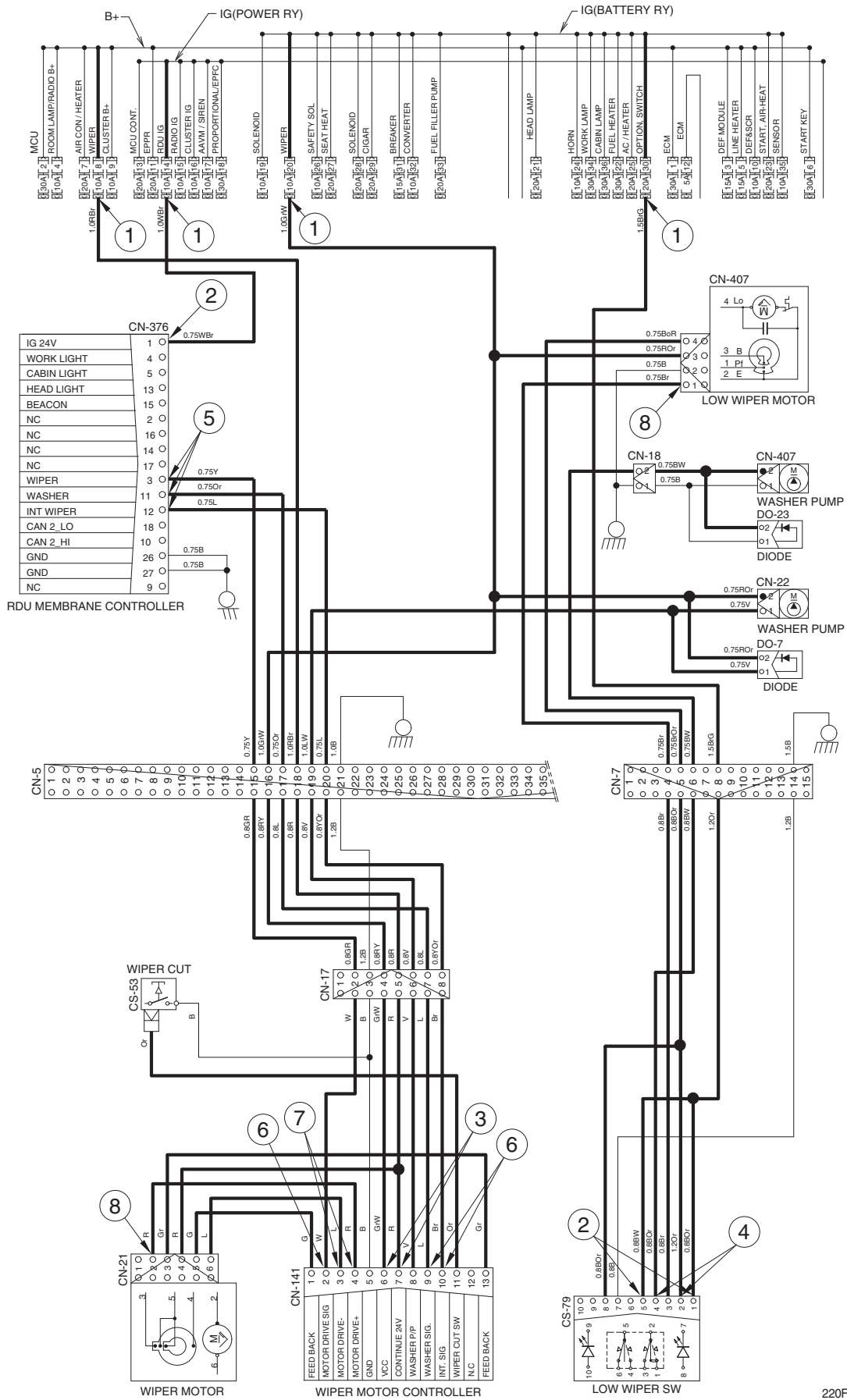

CONTROLLER CIRCUIT

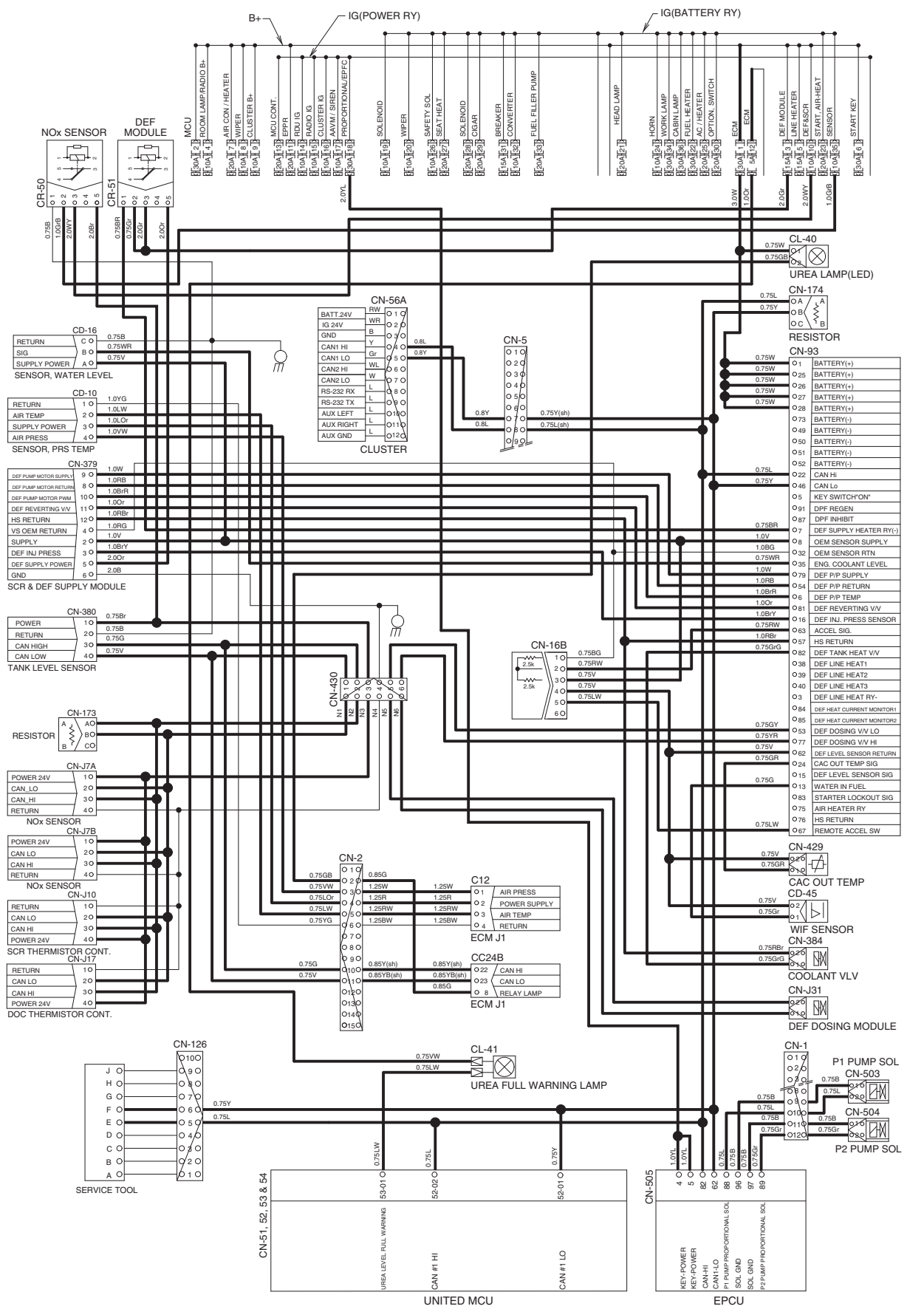

220F4EL111

MONITORING CIRCUIT

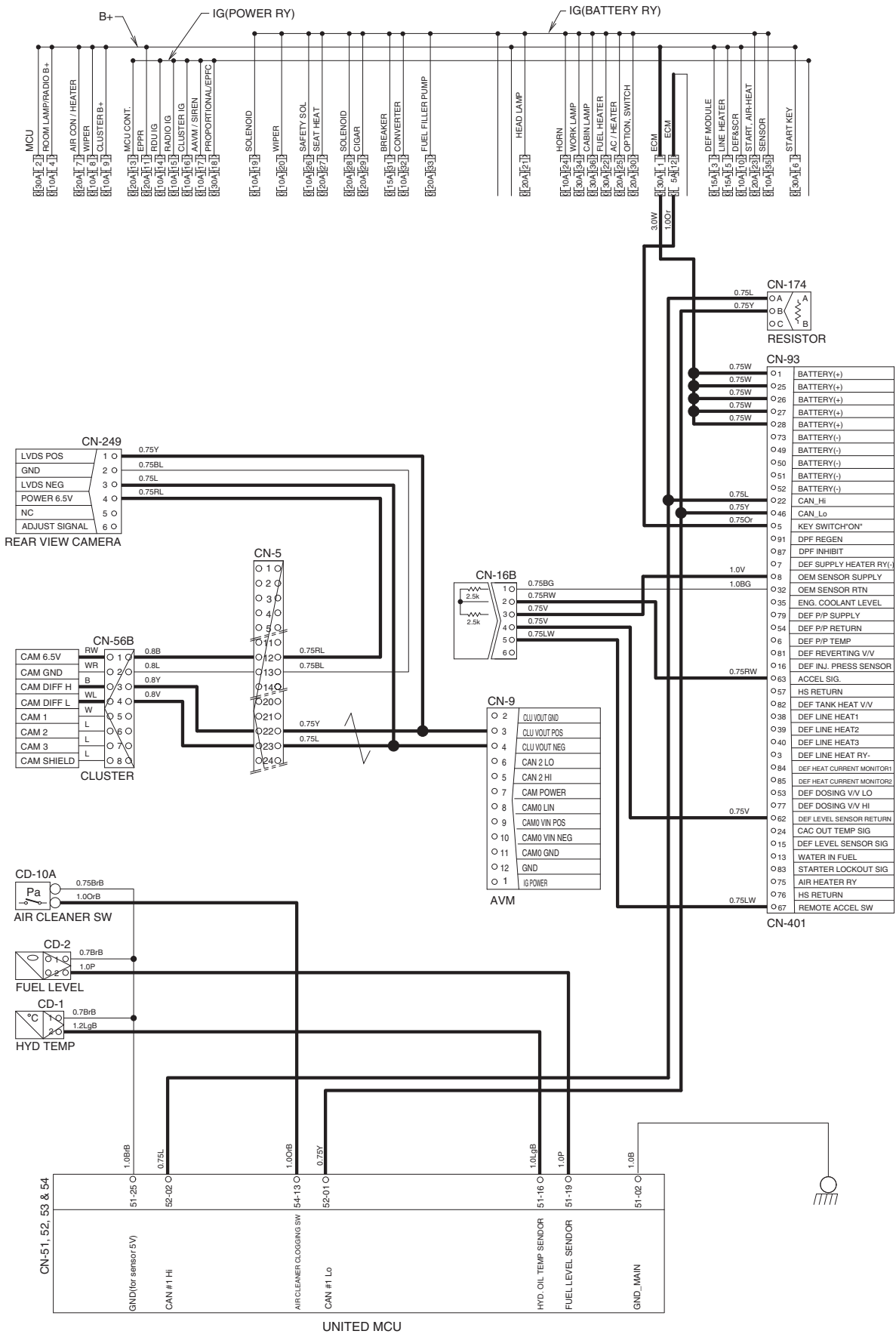

ELECTRIC CIRCUIT FOR HYDRAULIC (1/2)

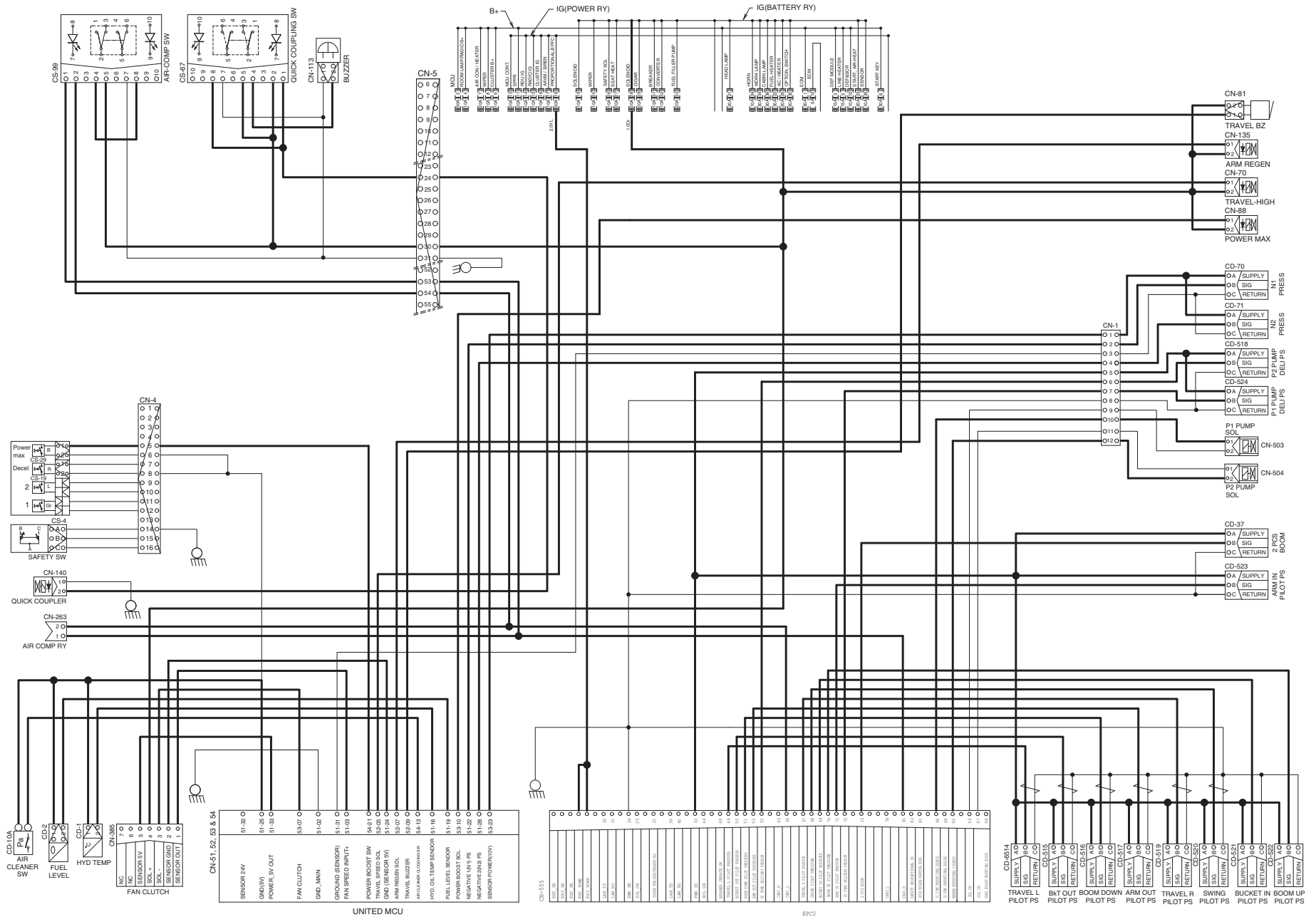

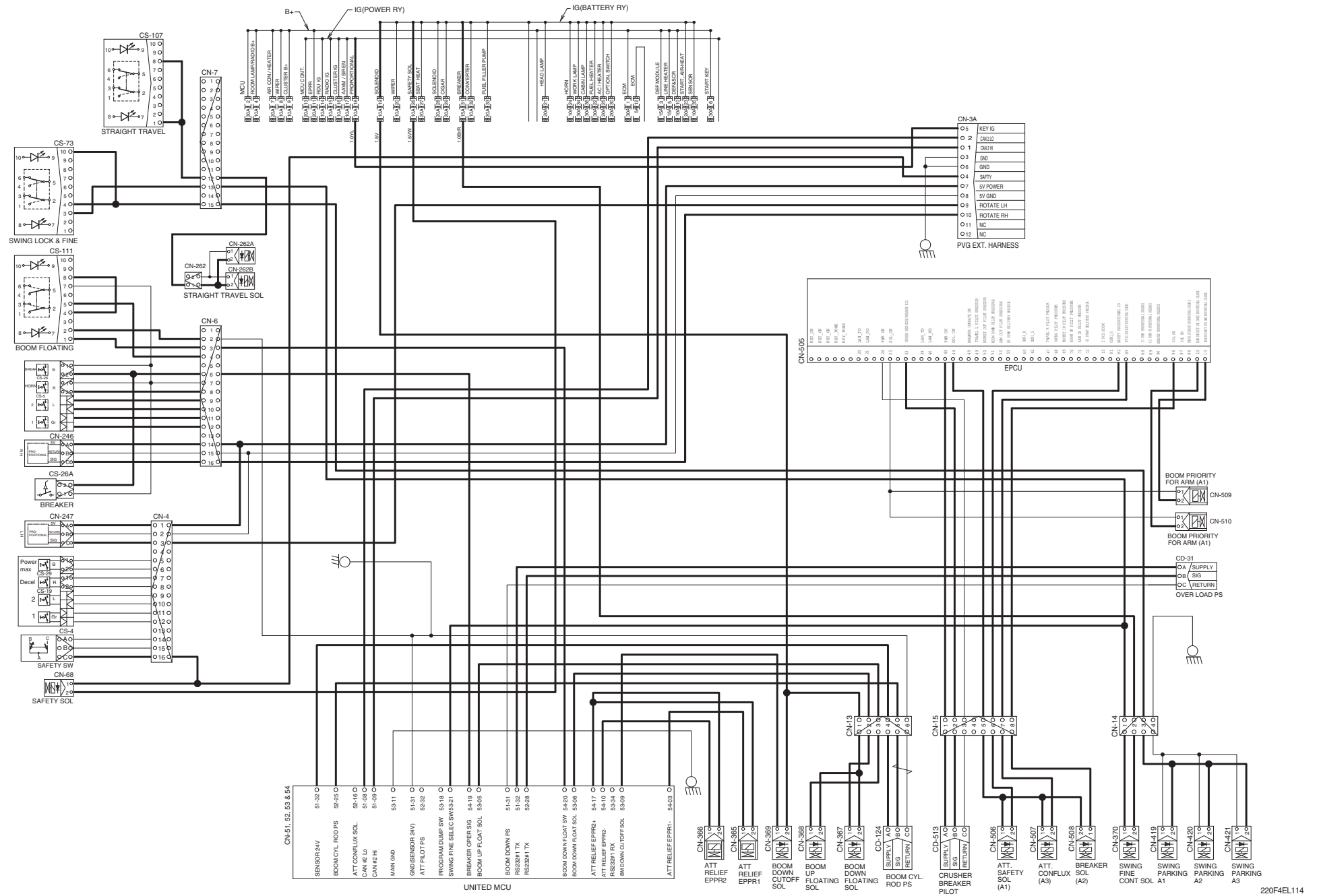

ELECTRIC CIRCUIT FOR HYDRAULIC (2/2)

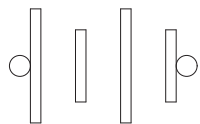
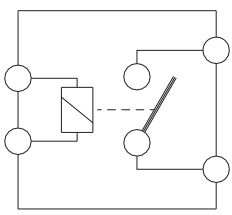
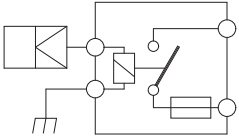
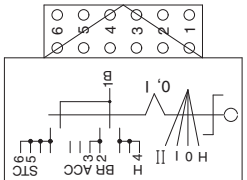
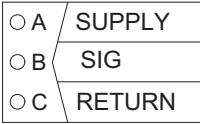
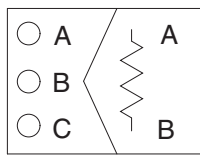

GROUP 3 ELECTRICAL COMPONENT SPECIFICATION

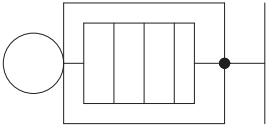
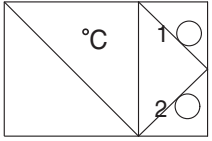
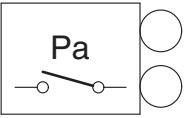
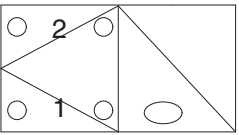
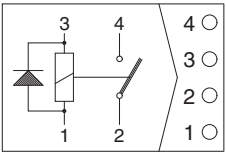
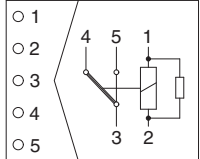
Part name	Symbol	Specifications	Check
Battery		12V × 160Ah (2EA)	※ Check specific gravity 1.280 over : Over charged 1.280 ~ 1.250 : Normal 1.250 below : Recharging
Battery relay	 <p style="text-align: center;">CR-1</p>	Rated load : 24V 100A (continuity) 1000A (30seconds)	※ Check coil resistance(M4 to M4) Normal : About 50Ω ※ Check contact Normal : ∞Ω
Glow plug relay	 <p style="text-align: center;">CR-24</p>	24V 200A	※ Check contact Normal : 0.942Ω (For terminal 1-GND)
Start key	 <p style="text-align: center;">CS-2</p>	B-BR : 24V 1A B-ACC : 24V 10A B-ST : 24V 40A	※ Check contact OFF : ∞Ω (for each terminal) ON : 0Ω (for terminal 1-3 and 1-2) START : 0Ω (for terminal 1-5)
Pressure sensor	 <p style="text-align: center;"> ○ A SUPPLY ○ B SIG ○ C RETURN </p> <p> CD-16 CD-31 CD-37 CD-70 CD-71 CD-124 CD-513 CD-514 CD-516 CD-517 CD-518 CD-519 CD-520 CD-521 CD-522 CD-523 CD-524 </p>	8~30V	※ Check contact Normal : 0.1Ω
Resistor	 <p style="text-align: center;"> ○ A ○ B ○ C </p> <p style="text-align: center;"> A A B B </p> <p style="text-align: center;">CN-173 CN-174</p>	3W	※ Check resistance A-B : 120Ω

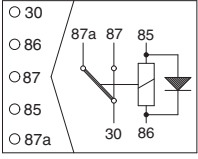
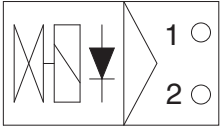
Part name	Symbol	Specifications	Check
Glow plug	 CN-80	24V 200A	※ Check resistance 0.25~0.12Ω
Temperature sensor (hydraulic)	 CD-1	-	※ Check resistance 50°C : 804Ω 80°C : 310Ω 100°C : 180Ω
Air cleaner pressure switch	 CD-10A	N.O TYPE	※ Check contact High level : ∞Ω Low level : 0Ω
Fuel level sender	 CD-2	-	※ Check resistance Full : 50Ω 6/12 : 350Ω 11/12 : 100Ω 5/12 : 400Ω 10/12 : 150Ω 4/12 : 450Ω 9/12 : 200Ω 3/12 : 500Ω 8/12 : 250Ω 2/12 : 550Ω 7/12 : 300Ω 1/12 : 600Ω Empty warning : 700Ω
Relay (air con blower)		24V 20A	※ Check resistance Normal : About 200Ω (for terminal 1-3) ∞Ω (for terminal 2-4)
Relay	 CR-2 CR-5 CR-36 CR-39 CR-50 CR-51 CR-85	24V 16A	※ Check resistance Normal : About 160 Ω (for terminal 1-2) 0Ω (for terminal 3-4) ∞Ω (for terminal 3-5)

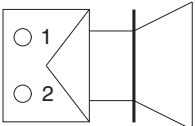
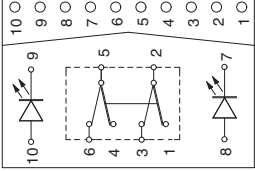
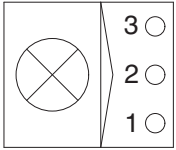
Part name	Symbol	Specifications	Check
Relay	 <p>CR-4 CR-7 CR-9 CR-13 CR-35 CR-46 CR-52</p>	24V 16A	※ Check resistance Normal : About 160 Ω (for terminal 85-86) 0 Ω (for terminal 30-87a) ∞ Ω (for terminal 30-87)
Solenoid valve	 <p>CN-68 CN-70 CN-88 CN-135 CN-140 CN-262A CN-262B CN-367 CN-368 CN-369 CN-370 CN-419 CN-420 CN-421</p>	24V 1A	※ Check resistance Normal : 15~25 Ω (for terminal 1-2)
EPPR valve	 <p>CN-365 CN-366</p>	700mA	※ Check resistance Normal : 15~25 Ω (for terminal 1-2)
Speaker	 <p>CN-23(LH) CN-24(RH)</p>	20W	※ Check resistance Normal : A few Ω
Switch (locking type)	 <p>CS-52 CS-67 CS-73 CS-83 CS-99 CS-107 CS-108 CS-111</p>	24V 1.5A	※ Check contact Normal ON : 0 Ω (for terminal 3-7, 4-8) ∞ Ω (for terminal 7-9, 8-10) OFF : ∞ Ω (for terminal 3-7, 4-8) 0 Ω (for terminal 7-9, 8-10)
Room lamp	 <p>CL-1</p>	24V 10W	※ Check disconnection Normal : 1.0 Ω ON : 0 Ω (For terminal 1-2) ∞ Ω (For terminal 1-3) OFF : ∞ Ω (For terminal 1-2) 0 Ω (For terminal 1-3)

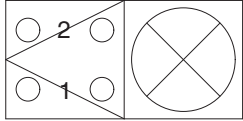
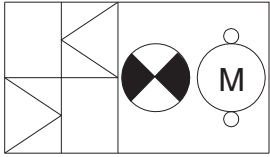
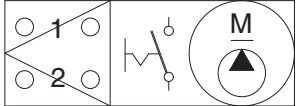
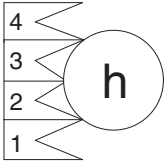
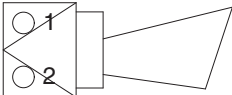
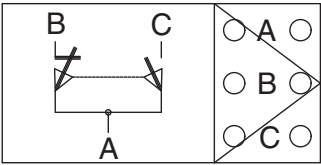
Part name	Symbol	Specifications	Check
Head lamp, Work lamp, Cab lamp	 <p>CL-3 CL-4 CL-5 CL-6 CL-8 CL-9 CL-10 CL-24</p>	24V 65W (H3 Type)	※ Check disconnection Normal : 1.2Ω
Beacon lamp	 <p>CL-7</p>	21V 70W (H1 Type)	※ Check disconnection Normal : A few Ω
Fuel filler pump	 <p>CN-61</p>	24V 10A 35 l /min	※ Check resistance Normal : 1.0Ω
Hour meter	 <p>CN-48</p>	16~32V	※ Check operation Supply power(24V) to terminal No.2 and connect terminal No.1 and ground
Horn	 <p>CN-20 CN-25</p>	DC22~28V 2A	※ Check operation Supply power(24V) to each terminal and connect ground.
Safety switch	 <p>CS-4</p>	24V 15A (N.C TYPE)	※ Check contact Normal : 0Ω (for terminal A-B) ∞Ω (for terminal A-C) Operating : ∞Ω (for terminal A-B) 0Ω (for terminal A-C)

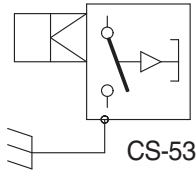
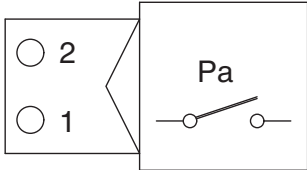
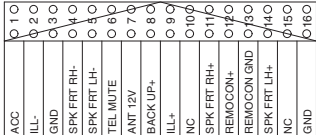
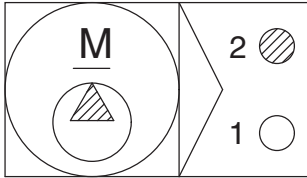
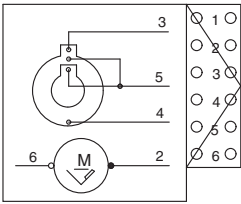
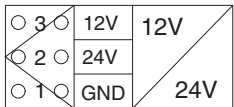
Part name	Symbol	Specifications	Check
Wiper cut switch	 <p>CS-53</p>	24V (N.O TYPE)	※ Check contact Normal : 0Ω (one pin to ground)
Receiver dryer	 <p>CN-29</p>	24V 2.5A	※ Check contact Normal : ∞Ω
Radio & USB player	 <p>CN-27A</p>	24V 2A	※ Check voltage 20~25V (for terminal 1-3, 3-8)
Washer pump	 <p>CN-22 CN-407</p>	24V 3.8A	※ Check contact Normal : 10.7Ω (for terminal 1-2)
Wiper motor	 <p>CN-21</p>	24V 2A	※ Check disconnection Normal : 7Ω (for terminal 2-6)
DC/DC Converter	 <p>CN-138</p>	12V 3A	※ Check voltage 24V (for terminal 1-2) 12V (for terminal 1-3)

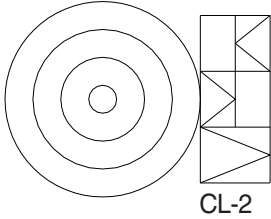
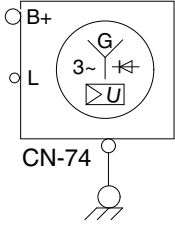
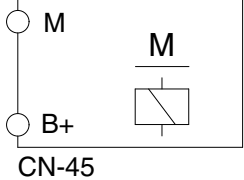
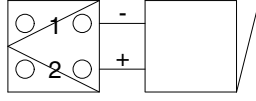
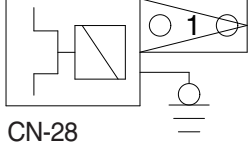
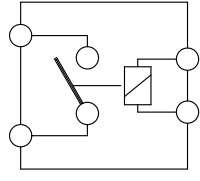
Part name	Symbol	Specifications	Check
Cigar lighter	 <p>CL-2</p>	24V 5A 1.4W	※ Check coil resistance Normal : About 1MΩ ※ Check contact Normal : ∞Ω Operating time : 5~15sec
Alternator	 <p>CN-74</p>	Delco Remy 24V 95A	※ Check contact Normal : 0Ω (for terminal B ⁺ -L) Normal : 24~27.5V
Starter	 <p>CN-45</p>	Denso 24V 4.8kW	※ Check contact Normal : 0.1Ω
Travel alarm	 <p>CN-81</p>	24V 0.5A	※ Check contact Normal : 5.2Ω
Air conditioner compressor	 <p>CN-28</p>	24V 79W	※ Check contact Normal : 13.4Ω
Start relay	 <p>CR-23</p>	24V 300A	※ Check contact Normal : 0.94Ω (for terminal 1-2)

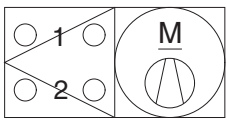
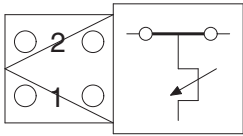
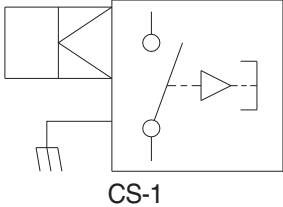
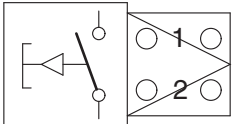
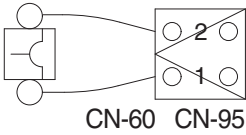
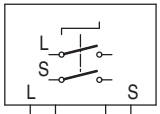
Part name	Symbol	Specifications	Check
Blower motor		24V 9.5A	※ Check resistance Normal : 2.5Ω (for terminal 1-2)
Duct sensor (switch)		1°C OFF 4°C ON	※ Check resistance Normal : 0Ω (for terminal 1-2), the atmosphere temp : Over 4°C
Door switch		24V 2W	※ Check resistance Normal : About 5MΩ
Switch (power max, one touch decel, horn, breaker)	 CS-5 CS-19 CS-26 CS-29	24V 6A	※ Check resistance Normal : ∞Ω
Circuit breaker	 CN-60 CN-95	60A	※ Check disconnection Normal : 0Ω (connect ring terminal and check resist between terminal 1 and 2)
Master switch	 CS-74 CS-74B	6-36V	※ Check disconnection Normal : 0.1Ω

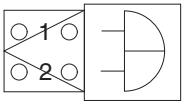
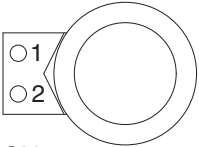
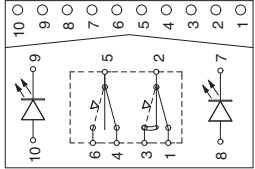
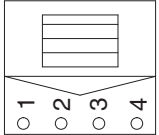
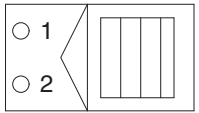
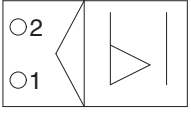
Part name	Symbol	Specifications	Check
Quick clamp buzzer	 <p>CN-113</p>	24V 200mA 107 ± 4dB	-
Socket	 <p>CN-139</p>	12V 10A	-
Switch	 <p>CS-79 CS-100</p>	24V 8A	※ Check contact Normal ON : 0Ω (for terminal 3-7, 4-8) ∞Ω (for terminal 7-9, 8-10) OFF : ∞Ω (for terminal 3-7, 4-8) 0Ω (for terminal 7-9, 8-10)
Fuel heater	 <p>CN-96</p>	-	-
DEF/AdBlue® line heater	 <p>CN-381 CN-382 CN-383</p>	-	-
WIF sensor	 <p>CD-45</p>	-	-

Part name	Symbol	Specifications	Check
DEF/AdBlue® sensor	<p>CN-J7A CN-J7B CN-J10 CN-J17</p>	-	-
CAC out temperature sensor	<p>CL-429</p>	-	-
DEF/AdBlue® fill up warning lamp (LED)	<p>CL-40</p>	-	-
Proportional valve sensor	<p>CN-246 CN-247</p>	-	-
EPPR valve	<p>CN-384 CN-J31</p>	24V	※ Check resistance Normal : 15~25Ω (For terminal 1-2)
Sensor	<p>CN-270</p>	-	-

GROUP 4 CONNECTORS

1. CONNECTOR DESTINATION

Connector number	Type	No. of pin	Destination	Connector part No.	
				Female	Male
CN-1	AMP	12	l/conn (Frame harness-Pump PS harness)	174661-2	174663-2
CN-2	AMP	15	l/conn (Frame harness-Engine harness)	2-85262-1	368301-1
CN-3	TYCO	12	l/conn (Frame harness-Pro vlv harness)	174661-2	368537-1
CN-4	AMP	16	l/conn (Console harness LH-Frame harness)	368047-1	368050-1
CN-5	DEUTSCH	60	l/conn (Frame harness-Side harness RH)	DRB16-60SAE-L018	DRB14-60PAE-L018
CN-6	AMP	16	l/conn (Console harness RH-Frame harness)	368047-1	368050-1
CN-7	AMP	15	l/conn (Console harness RH-Frame harness)	368301-1	2-85262-1
CN-8	AMP	10	l/conn (Console harness RH-Frame harness)	S816-010002	174655-2
CN-9	DEUTSCH	12	l/conn (Frame harness- AAVM harness)	DT06-12SA-P021	DT04-12PA-P021
CN-10	DEUTSCH	12	l/conn (Cab harness-Side harness RH)	DT06-12S-EP06	DT04-12PA-P021
CN-11	DEUTSCH	8	l/conn (Frame harness-Aircon harness)	DT06-8S-EP06	-
CN-12	DEUTSCH	2	l/conn (Frame harness-Boom wire harness)	DT06-2S-EP06	DT04-2P-E004
CN-13	AMP	6	Boom floating	174982-2	174264-2
CN-14	AMP	4	Swing parking & fine control	174257-2	174259-2
CN-15	AMP	8	l/conn (Frame harness-Breaker sol)	174982-2	174984-2
CN-16	AMP	6	Emergency engine start & speed control	S816-006002	S816-106002
CN-17	AMP	8	l/conn (Side harness RH-Wiper harness)	S816-008002	S816-108002
CN-18	AMP	2	Washer tank 2	174352-2	174354-2
CN-20	DEUTSCH	2	Horn	DT06-2S-EP06	-
CN-21	AMP	6	Wiper motor	S810-006202	-
CN-22	KET	2	Washer tank 1	MG640605	-
CN-23	KET	2	Speaker-LH	MG610070	-
CN-24	KET	2	Speaker-RH	MG610070	-
CN-25	DEUTSCH	2	Horn	DT06-2S-EP06	-
CN-27A	KUM	16	Radio & USB player	PK145-16017	-
CN-27B	AMP	8	Radio & USB player	-	174984-2
CN-28	KUM	1	Aircon compressor	NMWP01F-B	-
CN-29	KET	2	Receiver dryer	MG640795	-
CN-36	-	-	Fuse & relay box	21Q7-10910	-
CN-45	RING-TERM	-	Starter motor B+	S820-108000	-
CN-48	KET	1	Hour meter	2-520193-2	-
CN-51	TE	34	United MCU	2-1473285-3	-
CN-52	TE	34	United MCU	4-1437290-1	-
CN-53	TE	26	United MCU	1473416-1	-
CN-54	TE	34	United MCU	4-1437290-0	-
CN-56A	AMP	12	Cluster	-	174663-2
CN-56B	AMP	8	Cluster	-	174984-2
CN-60	YAZAKI	2	Circuit breaker	-	7222-4220-30

Connector number	Type	No. of pin	Destination	Connector part No.	
				Female	Male
CN-61	DEUTSCH	2	Fuel filler pump	DT06-2S-EP06	-
CN-68	DEUTSCH	2	Safety solenoid	DT06-2S-EP06	-
CN-70	DEUTSCH	2	Travel high solenoid	DT06-2S-EP06	-
CN-74	RING-TERM	1	Alternator "L" terminal	S820-108000	-
CN-80	RING-TERM	-	Glow plug	S820-306000	-
CN-81	DEUTSCH	2	Travel buzzer solenoid	DT06-2S-EP06	-
CN-88	DEUTSCH	2	Power max solenoid	DT06-2S-EP06	-
CN-93	DELPHI	-	ECM	13964577	-
CN-95	YAZAKI	2	Circuit breaker	-	7222-4220-30
CN-100	KET	1	ECM ground	MG640944-5	-
CN-113	KET	2	Buzzer	MG651205-5	-
CN-125	Econoseal J	4	RMS connector	S816-004002	S816-104002
CN-125A	DEUTSCH	12	RMS	DT06-12S-P021	DT04-12PA-P021
CN-126	TYCO	10	Service tool	2-1418390-1	S816-110002
CN-135	DEUTSCH	2	Arm regeneration solenoid	DT06-2S-EP06	-
CN-138	FASTEN	3	DC/DC Converter	S810-003202	-
CN-139	FASTEN	2	12V socket	172434-2	-
CN-140	DEUTSCH	2	Quick clamp solenoid	DT06-2S-EP06	DT04-2P-E005
CN-141	AMP	13	Wiper motor controller	172498-1	-
CN-147	AMP	4	Fuel heater	2-967325-3	-
CN-156	DEUTSCH	2	Air seat	DT06-2S	DT04-2P
CN-157	AMP	1	Antena power	S822-014002	-
CN-173	DEUTSCH	3	Resistor	DT06-3S-EP06	DT04-3P-EP10
CN-174	DEUTSCH	3	Resistor	DT06-3S-EP06	DT04-3P-EP10
CN-245	FCI	4	PTC power	180900-0	-
CN-246	DEUTSCH	3	Proportional valve-RH	DT06-3S	DT04-3P
CN-247	DEUTSCH	3	Proportional valve-LH	DT06-3S	DT04-3P
CN-249	DEUTSCH/AMP	4	Rear view camera	DT06-4S-EP06	174661-2
CN-258	KET	1	Air compressor power	MG640944-5	MG650943-5
CN-259	AMP	6	Camera	S816-006002	S816-106002
CN-260	YAZAKI	4	Speaker	-	SWF TYPE
CN-261	KET	4	Siren AMP	MG610047	-
CN-262	DEUTSCH	2	Straight travel solenoid	DT06-2S-EP06	DT04-2P-E005
CN-263	DEUTSCH	2	Air compressor relay	DT06-2S-EP06	DT04-2P-E005
CN-270	DEUTSCH	4	2D/3D MG	DT06-4S-EP06	DT04-4P-E005
CN-305	DEUTSCH	12	AAVM-Connector-1	DTM06-12SA	-
CN-306	DEUTSCH	12	AAVM-Connector-2	DTM06-12SB	-
CN-307	DEUTSCH	3	Proportional-Service tool	DT06-3S-E005	DT06-3P-EP06
CN-308	AMP	4	Proportional-PVG32	2-967056-1	-
CN-309	DEUTSCH	2	Proportional-EPPR valve-A1	DT06-2S-EP06	-

Connector number	Type	No. of pin	Destination	Connector part No.	
				Female	Male
CN-310	DEUTSCH	2	Proportional-EPPR valve-A2	DT06-2S-EP06	-
CN-363	AMP	12	Haptic controller	174045-2	-
CN-365	DEUTSCH	2	Attach EPPR valve-LH	DT06-2S-EP06	DT04-2P-E005
CN-366	DEUTSCH	2	Attach EPPR valve-RH	DT06-2S-EP06	DT04-2P-E005
CN-367	DEUTSCH	2	Boom down floating solenoid	DT06-2S-EP06	DT04-2P-E005
CN-368	DEUTSCH	2	Boom up floating solenoid	DT06-2S-EP06	DT04-2P-E005
CN-369	DEUTSCH	2	Boom down cut off solenoid	DT06-2S-EP06	DT04-2P-E005
CN-370	DEUTSCH	2	Swing fine control solenoid	DT06-2S-EP06	DT04-2P-E005
CN-376	TYCO	23	Membrane controller	7706087-2	-
CN-378	DEUTSCH	2	Attach EPPR 2	DT06-2S-EP06	-
CN-379	TYCO	12	SCR supply module	2-1703639-1	-
CN-381	TYCO	2	DEF line heater 1	C-0936059-01	-
CN-382	TYCO	2	DEF line heater 2	C-0936059-01	-
CN-383	TYCO	2	DEF line heater 3	C-0936059-01	-
CN-384	DEUTSCH	2	Coolant valve	DT06-2S-EP06	-
CN-385	-	7	Fan clutch	965570	-
CN-398	DEUTSCH	4	RS232	DT04-4S-E005	DT06-4P-E005
CN-399	TYCO	4	DEF tank level sensor	-	1-967325-1
CN-401	FCI	39	AAVM controller	-	-
CN-402	DEUTSCH	6	Front view camera	DT06-6S-P021	DT04-6P-P021
CN-403	DEUTSCH	6	Rear view camera	DT06-6S-EP06	DT04-6P-EP14
CN-404	DEUTSCH	6	LH view camera	DT06-6S-EP06	DT04-6P-EP14
CN-405	DEUTSCH	6	RH view camera	DT06-6S-EP06	DT04-6P-EP14
CN-406	DEUTSCH	3	Service tool	DT06-3S-E006	DT04-3P-EP05
CN-407	DEUTSCH	4	Low wiper motor	DT06-4S-E006	DT06-4P-E005
CN-408	FCI	4	Washer tank	MG640795	-
CN-419	DEUTSCH	2	Swing parking-A3	DT06-2S-EP06	-
CN-420	DEUTSCH	2	Swing parking-A2	DT06-2S-EP06	-
CN-421	DEUTSCH	2	Swing parking-A1	DT06-2S-EP06	-
CN-427	MOLEX	4	Reader-RMS	039012040	026013096
				5557-12R	5559-12P
CN-429	-	1	CAC Out temp sensor	S822-11400	-
CN-430	DEUTSCH	6	DEF dosing module	DT06-6S-EP06	-
CN-502	YAZAKI	4	Service tool	SWP type	SWP type
CN-503	AMP	2	P1 pump solenoid valve	174352-2	-
CN-504	AMP	2	P2 pump solenoid valve	174352-2	-
CN-505	TYCO	81	EPCU	1473244	-
CN-505	TYCO	40	EPCU	1473252	-
CN-506	DEUTSCH	2	Attach safety solenoid	DT06-2S-EP06	-

Connector number	Type	No. of pin	Destination	Connector part No.	
				Female	Male
CN-507	DEUTSCH	2	Attach conflux solenoid	DT06-2S-EP06	-
CN-508	DEUTSCH	2	Breaker solenoid	DT06-2S-EP06	-
CN-509	DEUTSCH	2	Boom priority sol for arm	DT06-2S-EP06	-
CN-510	DEUTSCH	2	Boom priority sol for swing	DT06-2S-EP06	-
CN-J7A	TYCO	4	DOC Nox sensor	2-1418390-1	-
CN-J7B	TYCO	4	SCR Nox sensor	1-1418390-1	-
CN-J10	TYCO	4	SCR Thermistor	3-1418390-1	-
CN-J17	TYCO	4	DOC Thermistor	4-1418390-1	-
CN-J31	BOSCH	2	DEF dosing module	1-928-403-874	-
· Relay					
CR-1	RING-TERM	-	Battery relay	ST710289-2	-
CR-2	-	5	Horn relay	-	-
CR-4	-	5	Working lamp relay	-	-
CR-5	-	5	Anti restart relay	-	-
CR-7	-	5	Aircon compressor relay	-	-
CR-9	-	5	Cabin lamp relay	-	-
CR-13	-	5	Head lamp relay	-	-
CR-23	KET	2	Start relay	S814-002001	S814-102001
CR-24	RING TERM	1	Preheat relay	S822-014000	-
CR-35	-	5	Power relay	-	-
CR-36	-	5	Preheat relay	-	-
CR-39	-	5	Starter lock out relay	-	-
CR-45	-	5	Beacon lamp relay	-	-
CR-46	-	5	Fuel warmer relay	-	-
CR-50	-	5	NOx sensor relay	-	-
CR-51	-	5	DEF module relay	-	-
CR-52	-	5	Line heater relay	-	-
· Switch					
CS-1	SHUR	1	Door switch	S822-014002	S822-114002
CS-2A	WP	6	Start key switch	S814-006100	-
CS-2B	DEUTSCH	3	Reader	DT06-3S-EP06	DT04-3P-E005
CS-4	DEUTSCH	3	Safety switch	DT06-3S-EP06	-
CS-5	DEUTSCH	2	Horn switch	-	DT04-2P
CS-19	DEUTSCH	2	One touch decel switch	-	DT04-2P-E005
CS-26	DEUTSCH	2	Breaker switch	DT06-2S-EP06	-
CS-26A	AMP	2	Breaker pedal switch	S816-002002	S816-102002
CS-29	DEUTSCH	2	Power max switch	DT06-2S-EP06	-
CS-33	AMP	6	Emergency engine stop switch	S816-006002	S816-106002
CS-52	CARLING	10	Adjust & dozer switch	VC2-01	-

Connector number	Type	No. of pin	Destination	Connector part No.	
				Female	Male
CS-53	AMP	1	Wiper cut switch	S822-014002	-
CS-67	CARLING	10	Quick clamp switch	VC2-01	-
CS-73	CARLING	10	Swing lock switch	VC2-01	-
CS-73A	CARLING	10	Swing fine switch	VC2-01	-
CS-74A	TYCO	2	Master switch	7706087-2	-
CS-74B	DEUTSCH	2	Master switch	DT06-2S-EP06	-
CS-79	CARLING	10	Lower wiper switch	VC2-01	-
CS-83	CARLING	10	Spare switch	VC2-01	-
CS-99	CARLING	10	Air compressor switch	VC2-01	-
CS-100	CARLING	10	SCR system cleaning switch	VC2-01	-
CS-107	CARLING	10	Travel straight switch	VC2-01	-
CS-108	CARLING	10	Auto grease switch	VC2-01	-
CS-111	CARLING	10	Boom floating switch	VC2-01	-
· Light					
CL-1	KET	3	Room lamp	MG651032	-
CL-2	AMP	1	Cigar light	S822-014002	S822-114002
CL-3	DEUTSCH	2	Head lamp-LH	DT06-2S-EP06	DT04-2P
CL-4	DEUTSCH	2	Head lamp-RH	DT06-2S-EP06	DT04-2P
CL-5	DEUTSCH	2	Work lamp-LH	DT06-2S-EP06	DT04-2P
CL-6	DEUTSCH	2	Work lamp-RH	DT06-2S-EP06	DT04-2P
CL-7	SHUR	1	Beacon lamp	S822-014002	S822-114002
CL-8	DEUTSCH	2	Cab light-LH	DT06-2S-EP06	DT04-2P
CL-9	DEUTSCH	2	Cab light-RH	DT06-2S-EP06	DT04-2P
CL-10	DEUTSCH	2	Cab light-RH	DT06-2S-EP06	DT04-2P
CL-24	DEUTSCH	2	Head lamp	DT06-2S-EP06	DT04-2P-E005
CL-36	DEUTSCH	2	Work lamp	DT06-2S-EP06	DT04-2P
CL-37	DEUTSCH	2	Work lamp	DT06-2S-EP06	DT04-2P
CL-40	DEUTSCH	2	DEF/AdBlue® purging lamp	DT06-2S-EP06	DT04-2P
CL-41	AMP	1	DEF/AdBlue® full/warning lamp	S822-01400	S822-11400
· Sensor, sendor					
CD-1	AMP	2	Hydraulic oil temp sender	85202-1	-
CD-2	DEUTSCH	2	Fuel sender	DT06-2S-EP06	-
CD-10	SUMITOMO	4	Air cleaner switch	6908-0144	-
CD-10A	AMP	2	Air cleaner switch	85202-1	-
CD-16	AMP	3	Water level sensor	12110293	-
CD-31	DEUTSCH	3	Overload pressure sensor	DT06-3S-EP06	-
CD-37	DEUTSCH	3	2 pcs boom perssure switch	DT06-3S-EP06	-
CD-45	DEUTSCH	2	WIF sensor	DT06-2S-EP06	-
CD-70	DEUTSCH	3	N1 pressure sensor	DT06-3S-EP06	-

Connector number	Type	No. of pin	Destination	Connector part No.	
				Female	Male
CD-71	DEUTSCH	3	N2 pressure sensor	DT06-3S-EP06	-
CD-124	DEUTSCH	3	Boom cylinder rod pressure snensor	DT06-3S-EP06	-
CD-513	DEUTSCH	3	Attach pressure sensor	DT06-3S-EP06	-
CD-514	DEUTSCH	3	LH travel pilot pressure sw	DT06-3S-EP06	-
CD-515	DEUTSCH	3	Bucket out pilot pressure sw	DT06-3S-EP06	-
CD-516	DEUTSCH	3	Boom down pilot pressure sw	DT06-3S-EP06	-
CD-517	DEUTSCH	3	Arm out pilot pressure sw	DT06-3S-EP06	-
CD-518	DEUTSCH	3	P2 pump delivery pressure sw	DT06-3S-EP06	-
CD-519	DEUTSCH	3	RH travel pilot pressure sw	DT06-3S-EP06	-
CD-520	DEUTSCH	3	Swing pilot pressure sw	DT06-3S-EP06	-
CD-521	DEUTSCH	3	Bucket in pilot pressure sw	DT06-3S-EP06	-
CD-522	DEUTSCH	3	Boom up pilot pressure sw	DT06-3S-EP06	-
CD-523	DEUTSCH	3	Arm in pilot pressure sw	DT06-3S-EP06	-
CD-524	DEUTSCH	3	P2 pump delivery pressure sw	DT06-3S-EP06	-

2. CONNECTION TABLE FOR CONNECTORS

1) PA TYPE CONNECTOR

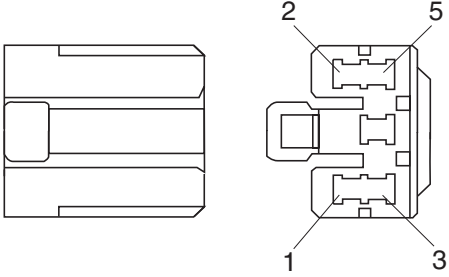
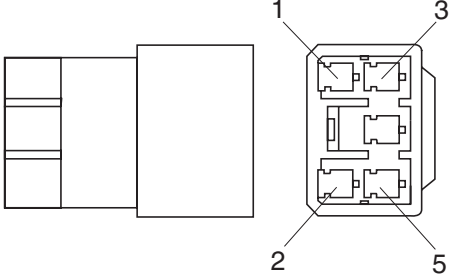
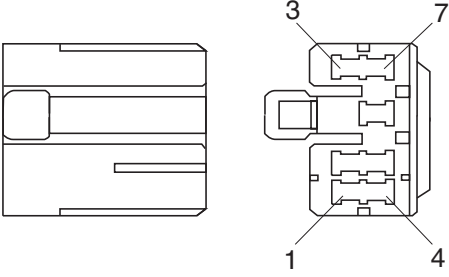
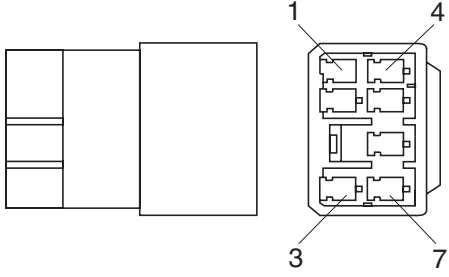
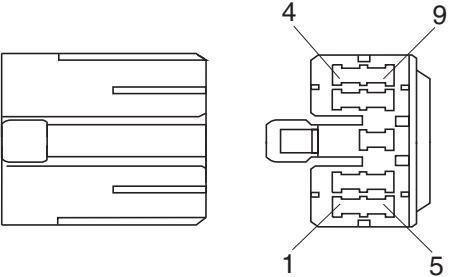
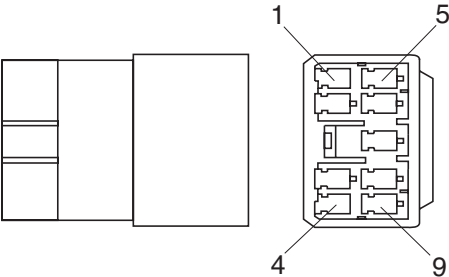
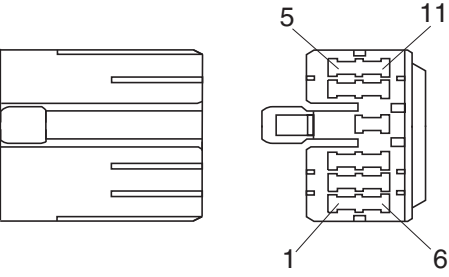
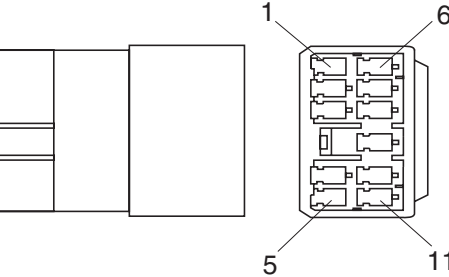
No. of pin	Receptacle connector (female)	Plug connector (male)
5	 <p style="text-align: center;">S811-005002</p>	 <p style="text-align: center;">S811-105002</p>
7	 <p style="text-align: center;">S811-007002</p>	 <p style="text-align: center;">S811-107002</p>
9	 <p style="text-align: center;">S811-009002</p>	 <p style="text-align: center;">3S811-109002</p>
11	 <p style="text-align: center;">S811-011002</p>	 <p style="text-align: center;">S811-111002</p>

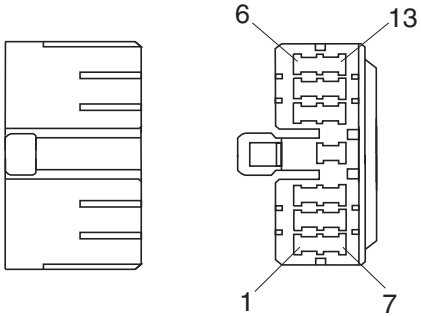
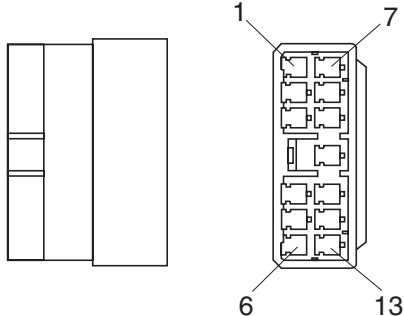
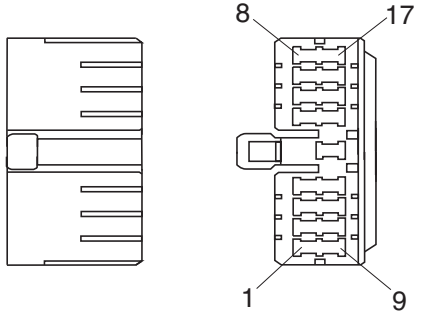
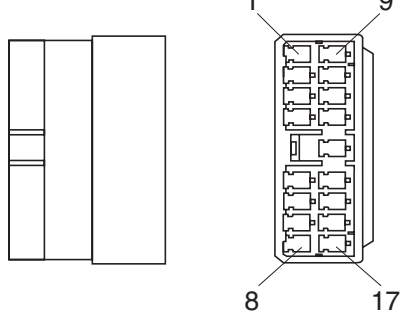
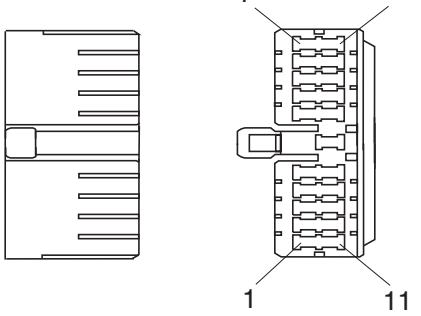
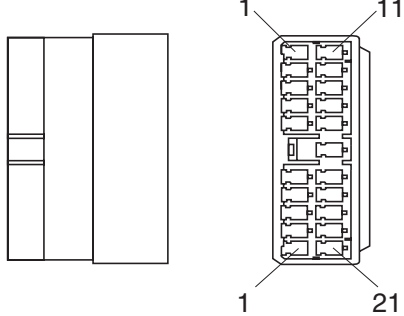
No. of pin	Receptacle connector (female)	Plug connector (male)
13	 <p style="text-align: center;">S811-013002</p>	 <p style="text-align: center;">S811-113002</p>
17	 <p style="text-align: center;">S811-017002</p>	 <p style="text-align: center;">S811-117002</p>
21	 <p style="text-align: center;">S811-021002</p>	 <p style="text-align: center;">S811-121002</p>

2) J TYPE CONNECTOR

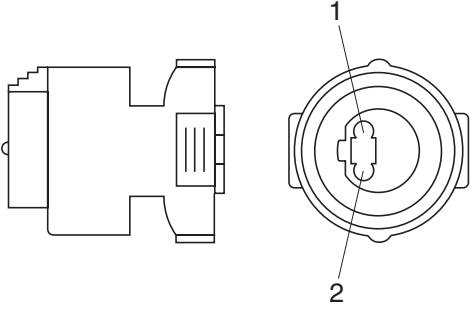
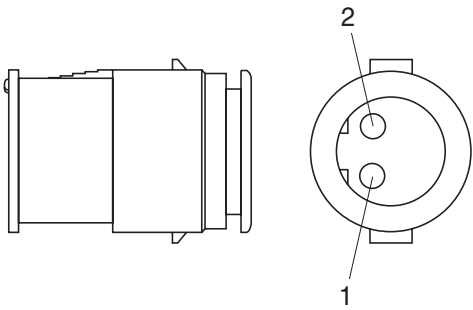
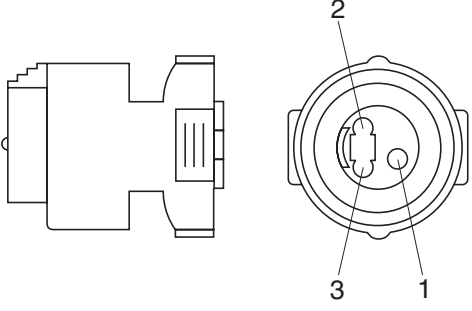
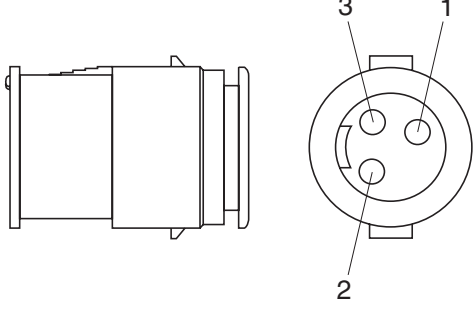
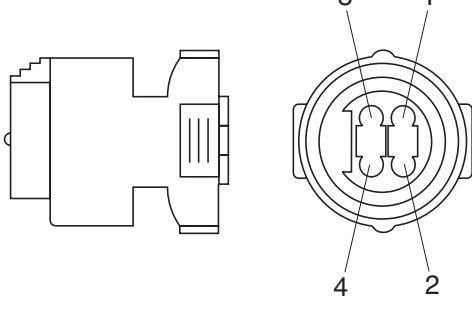
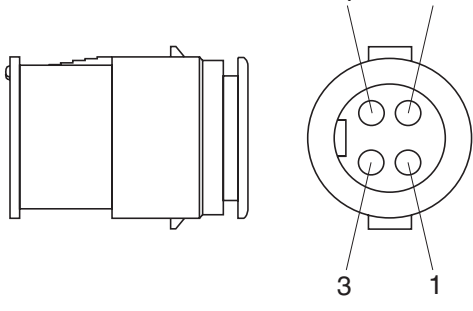
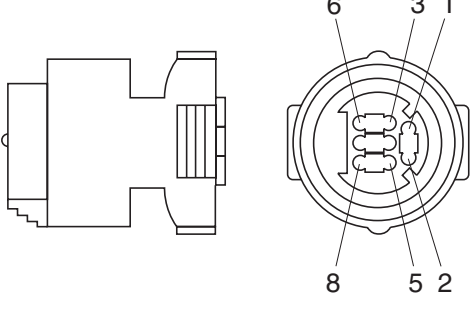
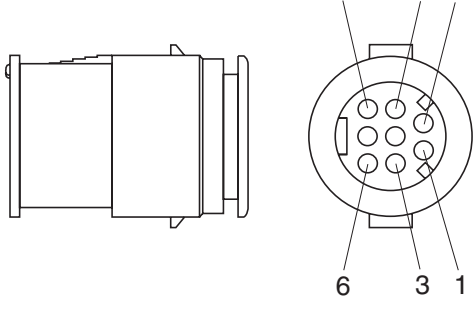
No. of pin	Receptacle connector (female)	Plug connector (male)
2	 <p style="text-align: center;">S816-002001</p>	 <p style="text-align: center;">S816-102001</p>
3	 <p style="text-align: center;">S816-003001</p>	 <p style="text-align: center;">S816-103001</p>
4	 <p style="text-align: center;">S816-004001</p>	 <p style="text-align: center;">S816-104001</p>
8	 <p style="text-align: center;">S816-008001</p>	 <p style="text-align: center;">S816-108001</p>

3) SWP TYPE CONNECTOR

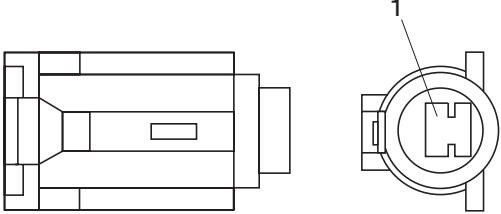
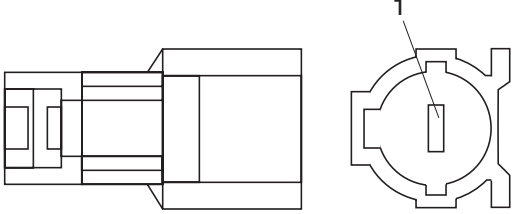
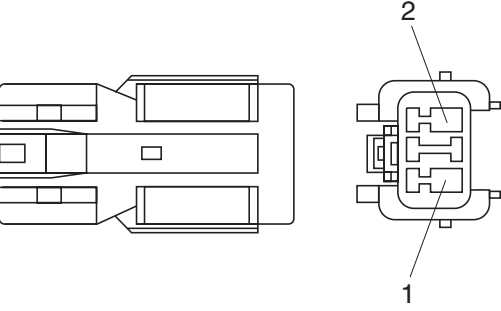
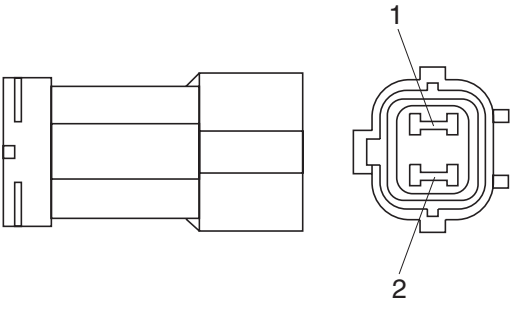
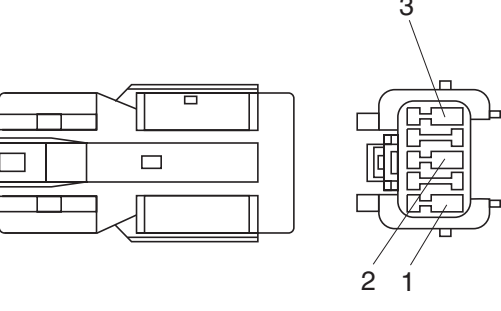
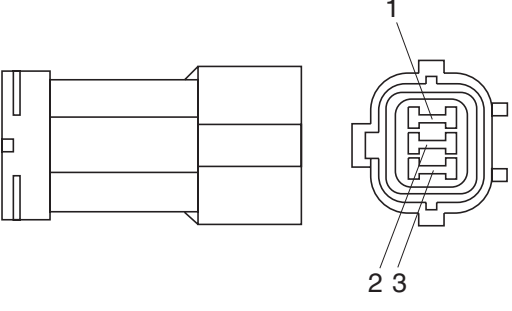
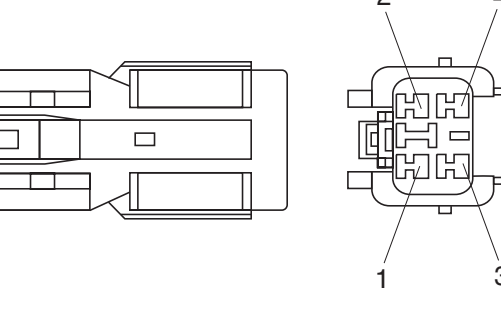
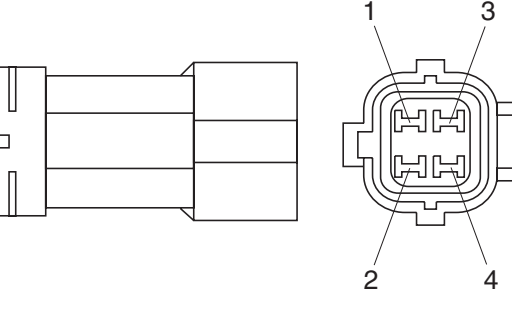
No. of pin	Receptacle connector (female)	Plug connector (male)
1	 <p data-bbox="687 680 836 707">S814-001000</p>	 <p data-bbox="1241 680 1390 707">S814-101000</p>
2	 <p data-bbox="687 1084 836 1111">S814-002000</p>	 <p data-bbox="1241 1084 1390 1111">S814-102000</p>
3	 <p data-bbox="687 1494 836 1520">S814-003000</p>	 <p data-bbox="1241 1494 1390 1520">S814-103000</p>
4	 <p data-bbox="687 1904 836 1930">S814-004000</p>	 <p data-bbox="1241 1904 1390 1930">S814-104000</p>

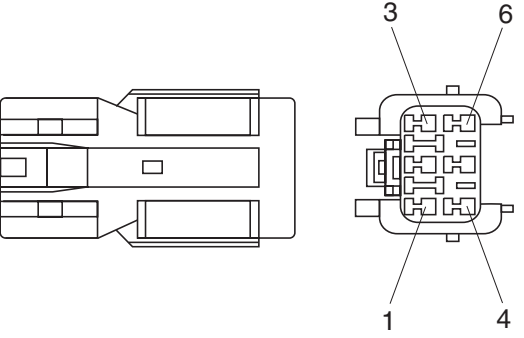
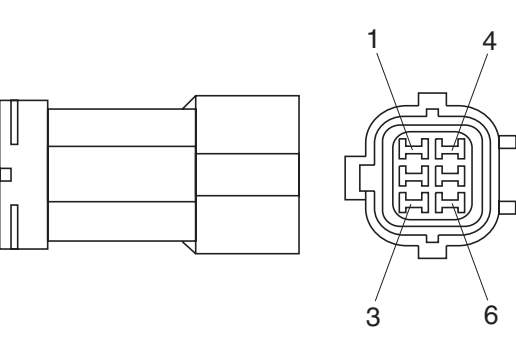
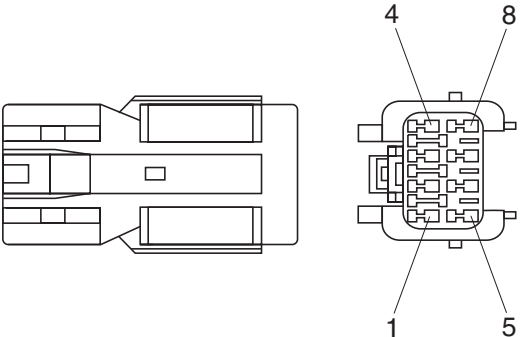
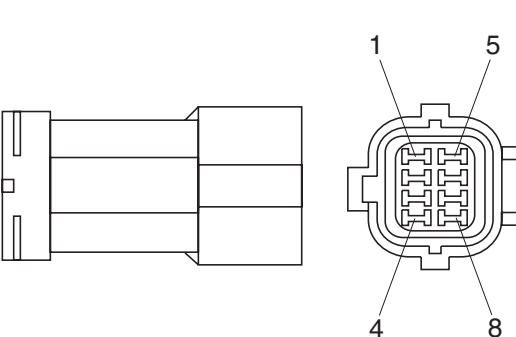
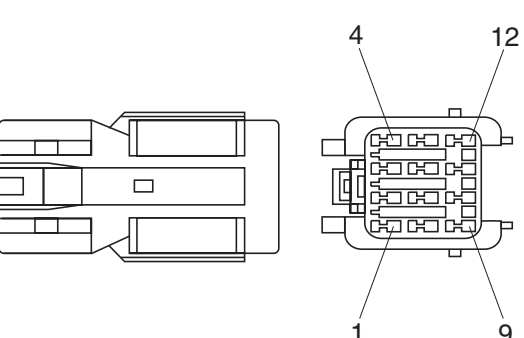
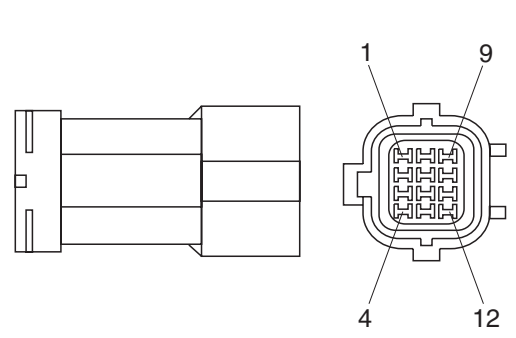
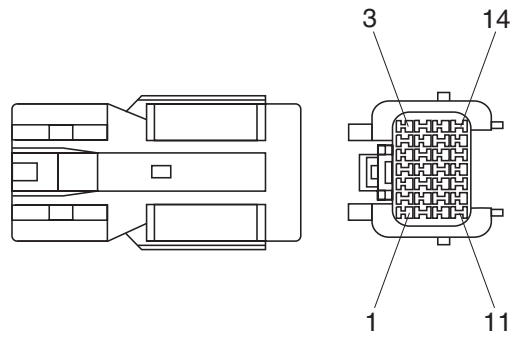
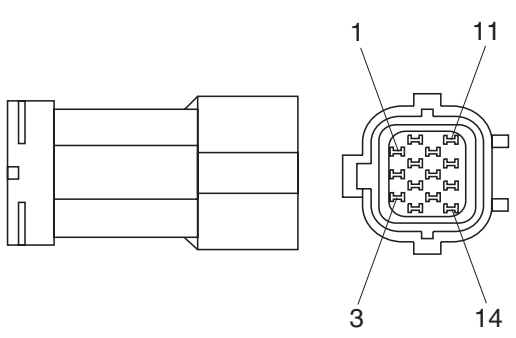
No. of pin	Receptacle connector (female)	Plug connector (male)
6	 <p data-bbox="686 638 837 672">S814-006000</p>	 <p data-bbox="1236 638 1388 672">S814-106000</p>
8	 <p data-bbox="686 1041 837 1075">S814-008000</p>	 <p data-bbox="1236 1041 1388 1075">S814-108000</p>
12	 <p data-bbox="686 1449 837 1482">S814-012000</p>	 <p data-bbox="1236 1449 1388 1482">S814-112000</p>
14	 <p data-bbox="686 1856 837 1890">S814-014000</p>	 <p data-bbox="1236 1856 1388 1890">S814-114000</p>

4) CN TYPE CONNECTOR

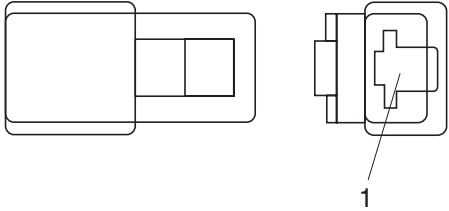
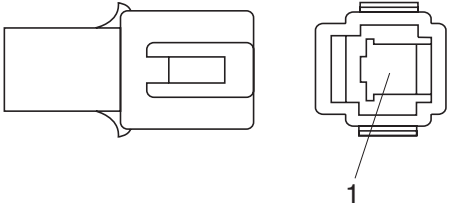
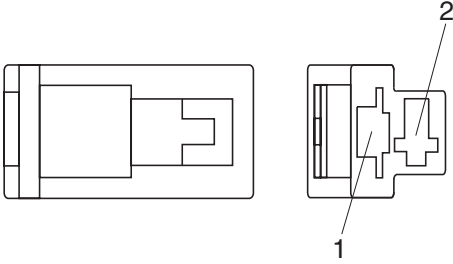
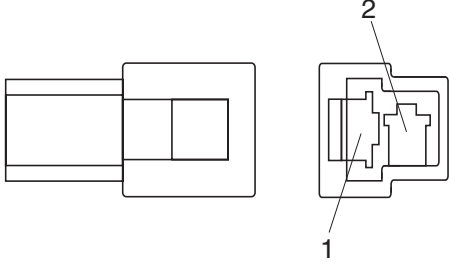
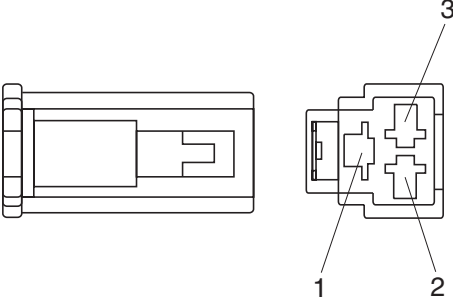
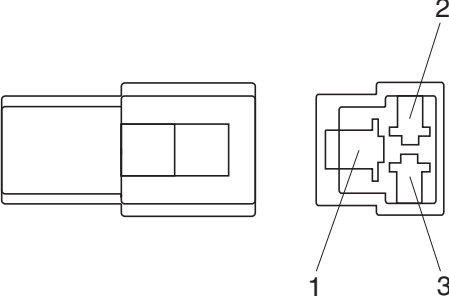
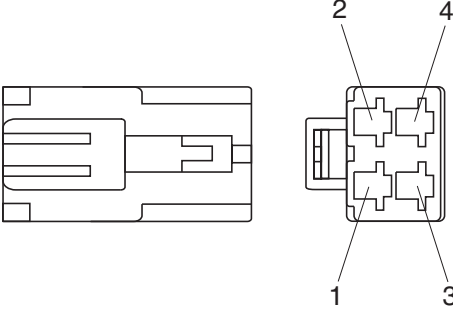
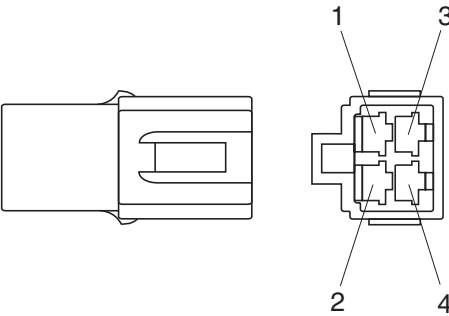
No. of pin	Receptacle connector (female)	Plug connector (male)
1	 <p data-bbox="687 680 836 707">S810-001202</p>	 <p data-bbox="1240 680 1388 707">S810-101202</p>
2	 <p data-bbox="687 1086 836 1113">S810-002202</p>	 <p data-bbox="1240 1086 1388 1113">S810-102202</p>
3	 <p data-bbox="687 1496 836 1523">S810-003202</p>	 <p data-bbox="1240 1496 1388 1523">S810-103202</p>
4	 <p data-bbox="687 1901 836 1928">S810-004202</p>	 <p data-bbox="1240 1901 1388 1928">S810-104202</p>

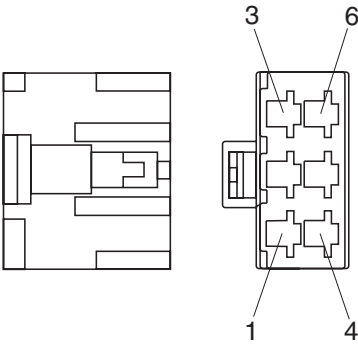
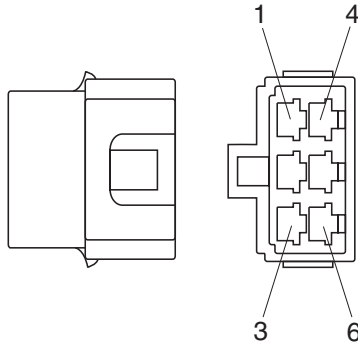
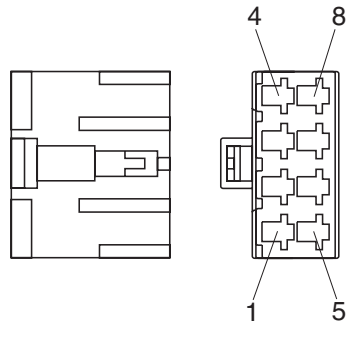
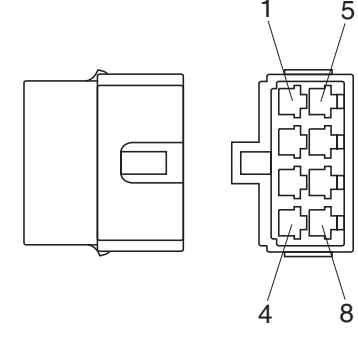
No. of pin	Receptacle connector (female)	Plug connector (male)
6	 <p data-bbox="686 638 837 672">S810-006202</p>	 <p data-bbox="1244 638 1396 672">S810-106202</p>
8	 <p data-bbox="686 1041 837 1075">S810-008202</p>	 <p data-bbox="1244 1041 1396 1075">S810-108202</p>

5) 375 FASTEN TYPE CONNECTOR

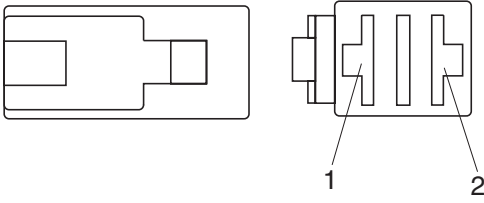
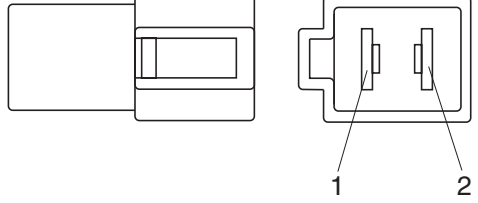
No. of pin	Receptacle connector (female)	Plug connector (male)
2	 <p style="text-align: center;">S810-002402</p>	 <p style="text-align: center;">S810-102402</p>

6) AMP ECONOSEAL CONNECTOR

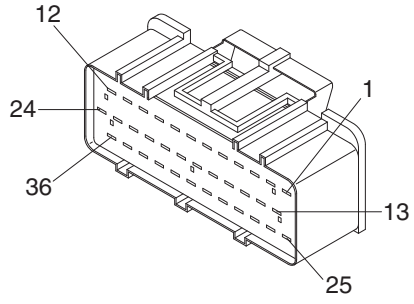
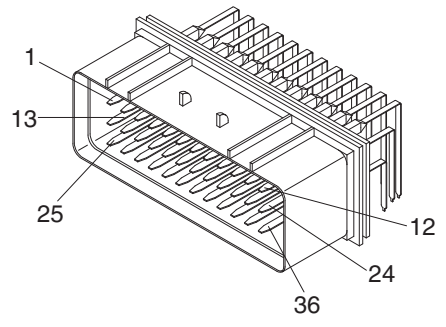
No. of pin	Receptacle connector (female)	Plug connector (male)
36	 <p style="text-align: center;">344111-1</p>	 <p style="text-align: center;">344108-1</p>

7) AMP TIMER CONNECTOR

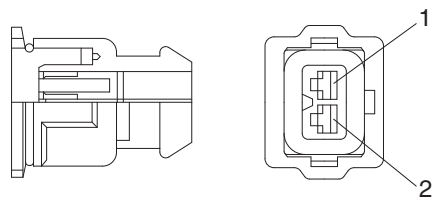
No. of pin	Receptacle connector (female)	Plug connector (male)
2	 <p style="text-align: center;">85202-1</p>	

8) AMP 040 MULTILOCK CONNECTOR

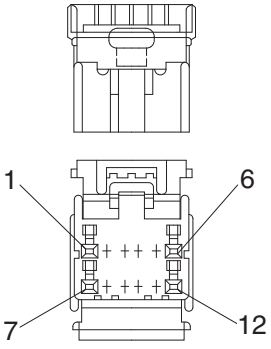
No. of pin	Receptacle connector (female)	Plug connector (male)
12	 <p style="text-align: right;">174045-2</p>	

9) AMP 070 MULTILOCK CONNECTOR

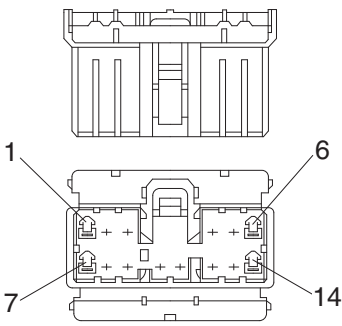
No. of pin	Receptacle connector (female)	Plug connector (male)
14	 <p style="text-align: right;">173852</p>	

10) AMP FASTIN - FASTON CONNECTOR

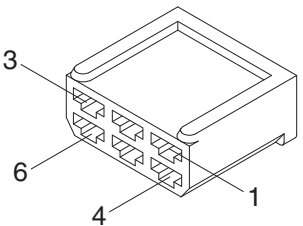
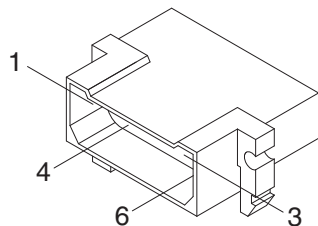
No. of pin	Receptacle connector (female)	Plug connector (male)
6	 <p style="text-align: right;">925276-0</p>	 <p style="text-align: right;">480003-9</p>

11) KET 090 CONNECTOR

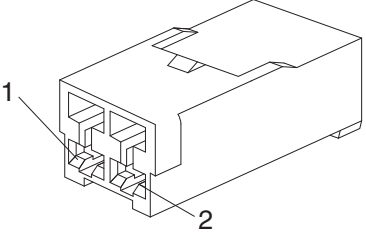
No. of pin	Receptacle connector (female)	Plug connector (male)
2	 <p style="text-align: right;">MG610070</p>	

12) KET 090 WP CONNECTORS

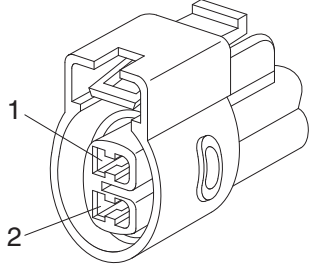
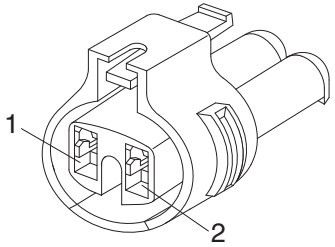
No. of pin	Receptacle connector (female)	Plug connector (male)
2	 <p style="text-align: right;">MG640605</p>	
2	 <p style="text-align: right;">MG640795</p>	

13) KET SDL CONNECTOR

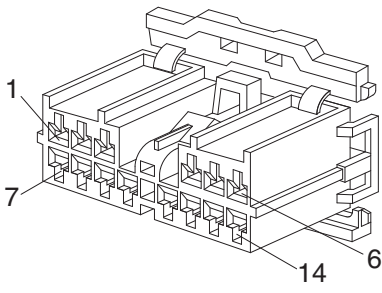
No. of pin	Receptacle connector (female)	Plug connector (male)
14	 <p data-bbox="710 672 837 705">MG610406</p>	

14) DEUTSCH DT CONNECTORS

DT 06 - 3S - ★★☆☆

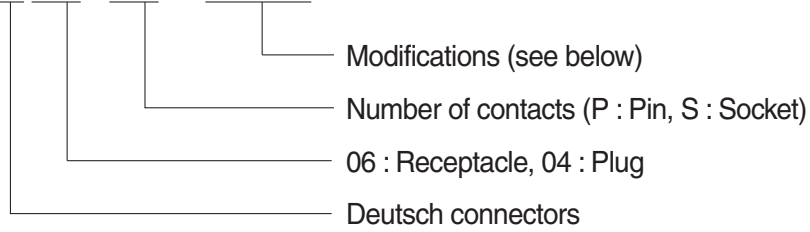

※ Modification

E003 : Standard end cap - gray

E004 : Color of connector to be black

E005 : Combination - E004 & E003

EP04 : End cap

EP06 : Combination P012 & EP04

P012 : Front seal enhancement - connectors color to black for 2, 3, 4 & 6pin

No. of pin	Receptacle connector (female)	Plug connector (male)
2	<p>DT06-2S</p>	<p>DT04-2P</p>
3	<p>DT06-3S</p>	<p>DT04-3P</p>
4	<p>DT06-4S</p>	<p>DT04-4P</p>

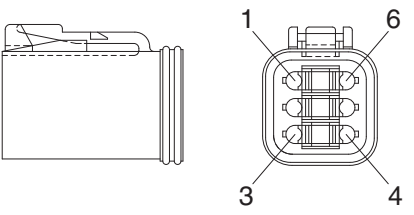
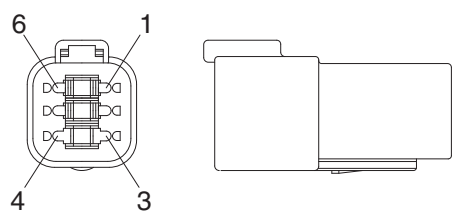
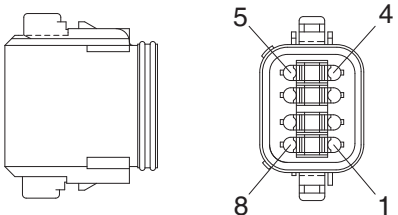
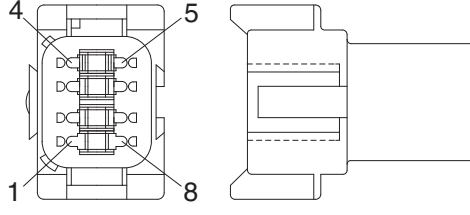
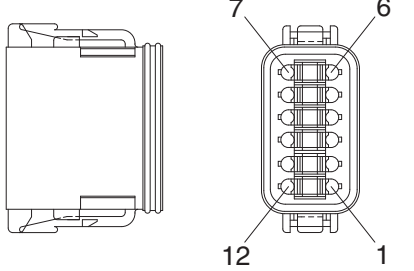
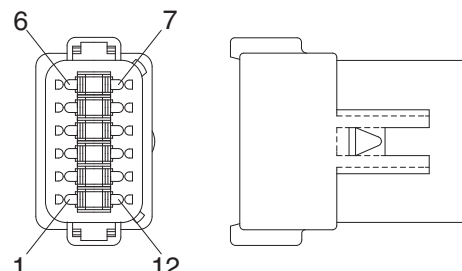
No. of pin	Receptacle connector (female)	Plug connector (male)
6	 <p style="text-align: center;">DT06-6S</p>	 <p style="text-align: center;">DT04-6P</p>
8	 <p style="text-align: center;">DT06-8S</p>	 <p style="text-align: center;">DT04-8P</p>
12	 <p style="text-align: center;">DT06-12S</p>	 <p style="text-align: center;">DT04-12P</p>

15) MOLEX 2CKTS CONNECTOR

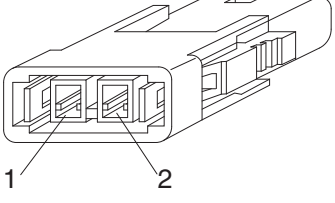
No. of pin	Receptacle connector (female)	Plug connector (male)
2	 <p style="text-align: right;">35215-0200</p>	

16) ITT SWF CONNECTOR

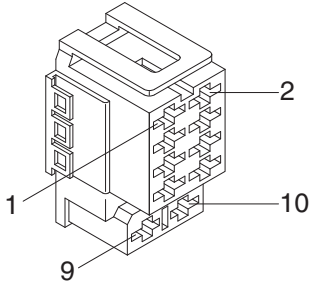
No. of pin	Receptacle connector (female)	Plug connector (male)
10	 <p style="text-align: right;">SWF593757</p>	

17) MWP NMWP CONNECTOR

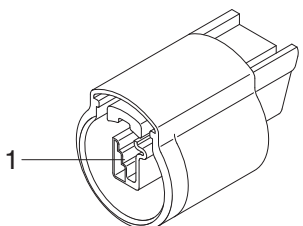
No. of pin	Receptacle connector (female)	Plug connector (male)
1	 <p style="text-align: right;">NMWP01F-B</p>	

18) ECONOSEAL J TYPE CONNECTORS

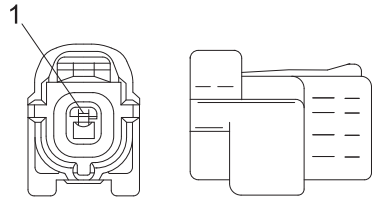
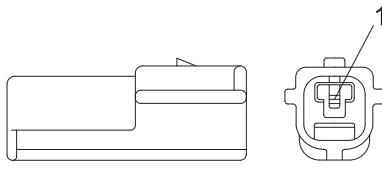
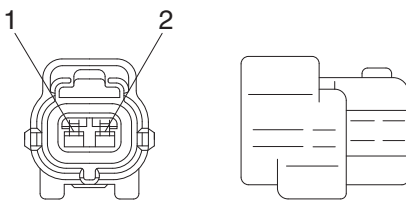
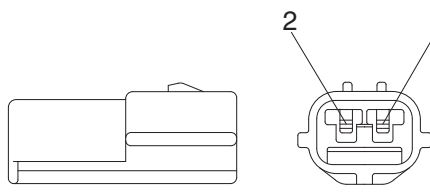
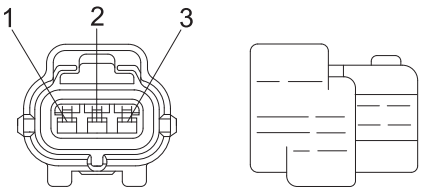
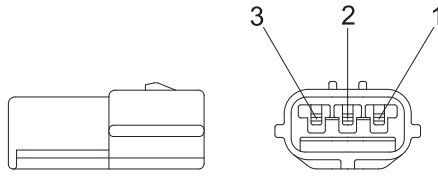
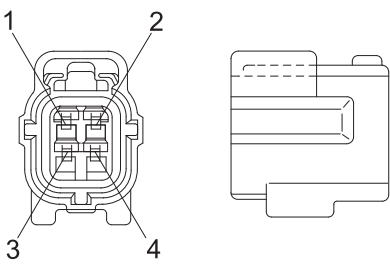
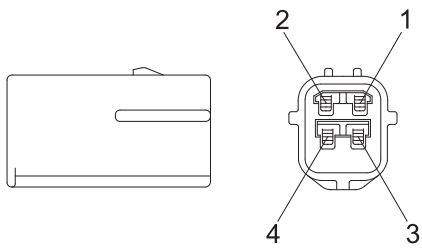
No. of pin	Receptacle connector (female)	Plug connector (male)
1	 <p style="text-align: right;">S816-001002</p>	 <p style="text-align: right;">S816-101002</p>
2	 <p style="text-align: right;">S816-002002</p>	 <p style="text-align: right;">S816-102002</p>
3	 <p style="text-align: right;">S816-003002</p>	 <p style="text-align: right;">S816-103002</p>
4	 <p style="text-align: right;">S816-004002</p>	 <p style="text-align: right;">S816-104002</p>

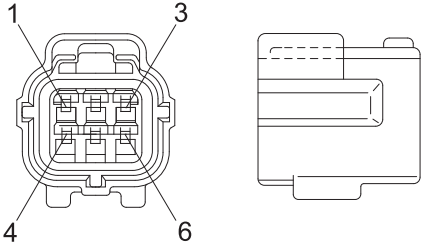
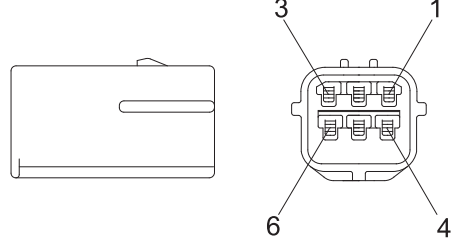
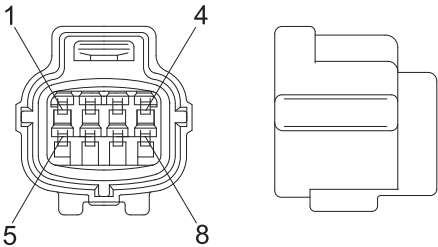
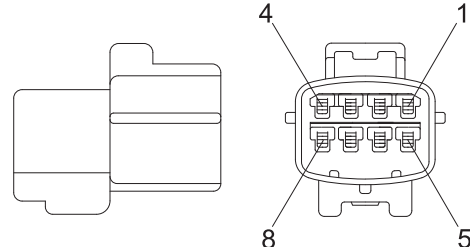
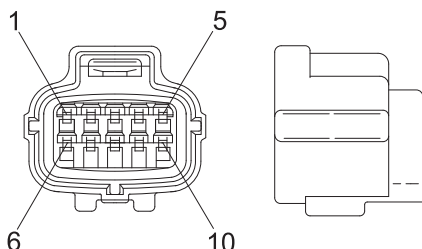
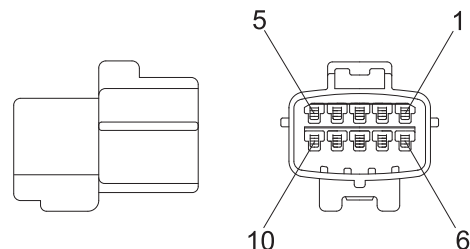
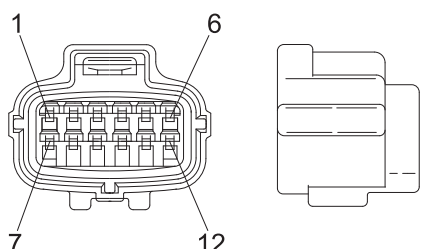
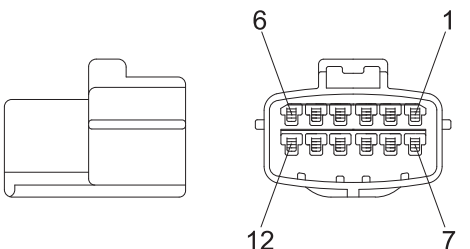
No. of pin	Receptacle connector (female)	Plug connector (male)
6	 <p style="text-align: center;">S816-006002</p>	 <p style="text-align: center;">S816-106002</p>
8	 <p style="text-align: center;">S816-008002</p>	 <p style="text-align: center;">S816-108002</p>
10	 <p style="text-align: center;">S816-010002</p>	 <p style="text-align: center;">S816-110002</p>
12	 <p style="text-align: center;">S816-012002</p>	 <p style="text-align: center;">S816-112002</p>

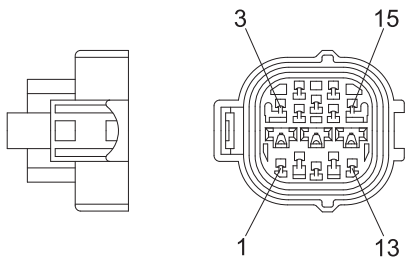
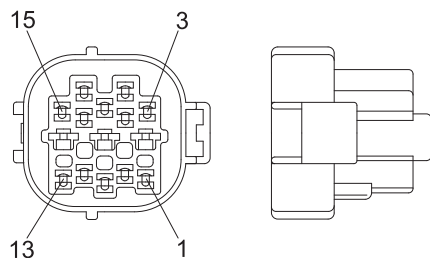
No. of pin	Receptacle connector (female)	Plug connector (male)
15	 <p style="text-align: right;">368301-1</p>	 <p style="text-align: right;">2-85262-1</p>

19) METRI-PACK TYPE CONNECTOR

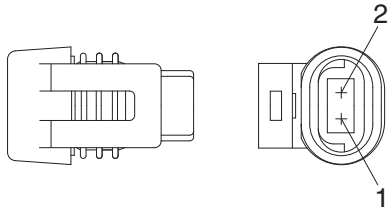
No. of pin	Receptacle connector (female)	Plug connector (male)
2	 <p style="text-align: right;">12040753</p>	

20) DEUTSCH HD30 CONNECTOR

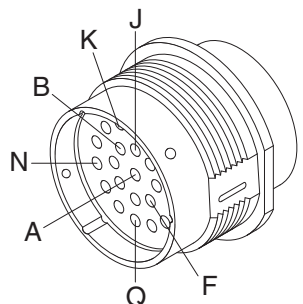
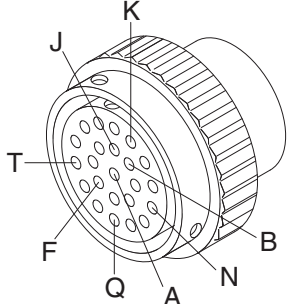
No. of pin	Receptacle connector (female)	Plug connector (male)
23	 <p style="text-align: right;">HD36-24-23SN</p>	 <p style="text-align: right;">HD34-24-23PN</p>

21) DEUTSCH SERVICE TOOL CONNECTOR

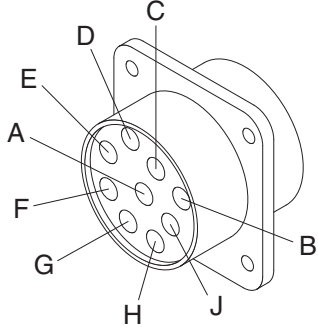
No. of pin	Receptacle connector (Female)	Plug connector (Male)
9	 <p style="text-align: right;">HD10-9-96P</p>	

22) AMP FUEL WARMER CONNECTOR

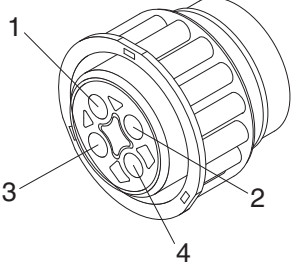
No. of pin	Receptacle connector (Female)	Plug connector (Male)
4	 <p style="text-align: right;">2-967325-3</p>	

23) DEUTSCH ENGINE ECM CONNECTOR

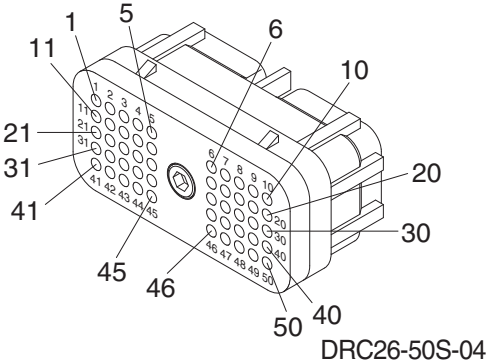
No. of pin	Receptacle connector (Female)	Plug connector (Male)
50	 <p style="text-align: right;">DRC26-50S-04</p>	

24) DEUTSCH INTERMEDIATE CONNECTOR

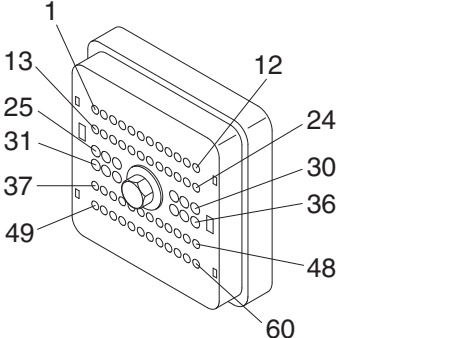
No. of pin	Receptacle connector (Female)	Plug connector (Male)
60	 <p style="text-align: right;">DRB16-60SAE-L018</p>	

25) TE MCU CONNECTOR

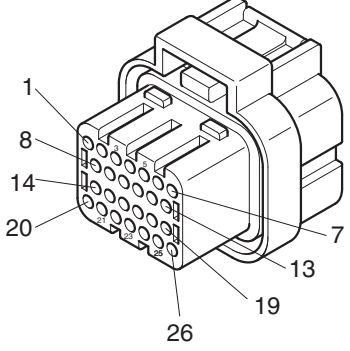
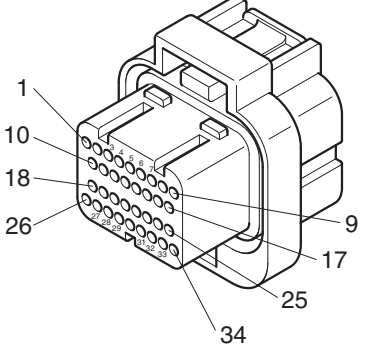
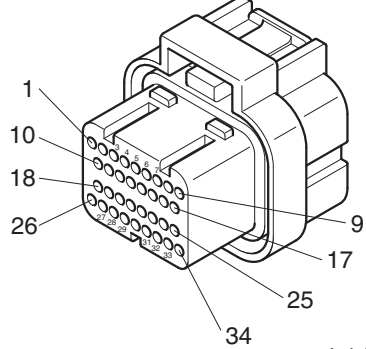
No. of pin	Receptacle connector (female)	Plug connector (male)
26	 <p style="text-align: right;">1473416-1</p>	
34	 <p style="text-align: right;">2-1437285-3 4-1437290-0</p>	
34	 <p style="text-align: right;">4-1437290-1</p>	