

SECTION 6 TROUBLESHOOTING

| | |
|---|------|
| Group 1 Before Troubleshooting | 6-1 |
| Group 2 Hydraulic and Mechanical System | 6-4 |
| Group 3 Electrical System | 6-25 |
| Group 4 Mechatronics System | 6-43 |
| Group 5 Air conditioner and Heater System | 6-71 |

GROUP 1 BEFORE TROUBLESHOOTING

1. INTRODUCTION

When a trouble is occurred in the machine, this section will help an operator to maintain the machine with easy.

The trouble of machine is parted Hydraulic & Mechanical system, Electrical system, Mechatronics system and Air conditioner and heater system. At each system part, an operator can check the machine according to the troubleshooting process diagram.

※ Before carrying out troubleshooting procedure, check monitoring menu in the cluster.

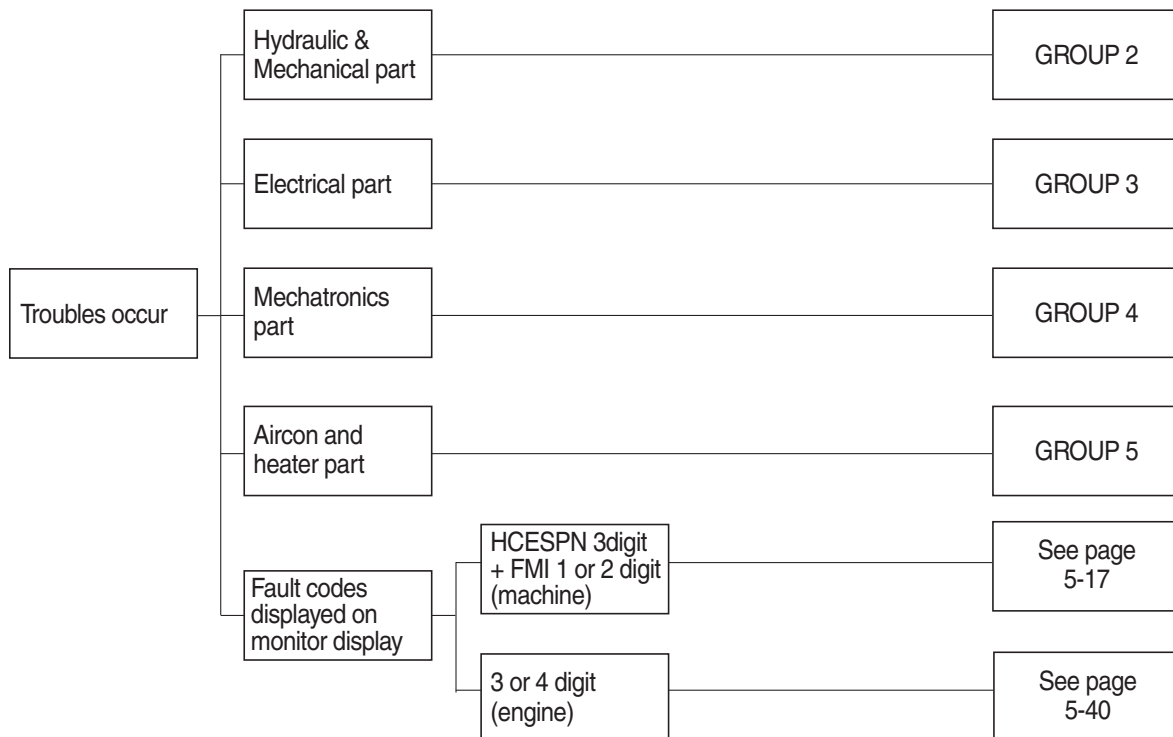

2. DIAGNOSING PROCEDURE

To carry out troubleshooting efficiently, the following steps must be observed.

STEP 1. Study the machine system

Study and know how the machine is operating, how the system is composing, what kinds of function are installed in the machine and what are specifications of the system components by the machine service manual.

Especially, deepen the knowledge for the related parts of the trouble.

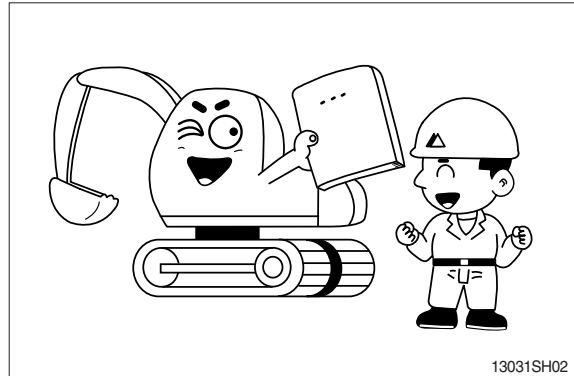

STEP 2. Ask the operator

Before inspecting, get the full story of malfunctions from a witness --- the operator.

- 1) How the machine is used and when it is serviced?
- 2) When the trouble was noticed and what work the machine was doing at that time?
- 3) What is the phenomenon of the trouble?
Was the trouble getting worse, or did it come out suddenly for the first time?
- 4) Did the machine have any troubles previously? If so, which parts were repaired before.

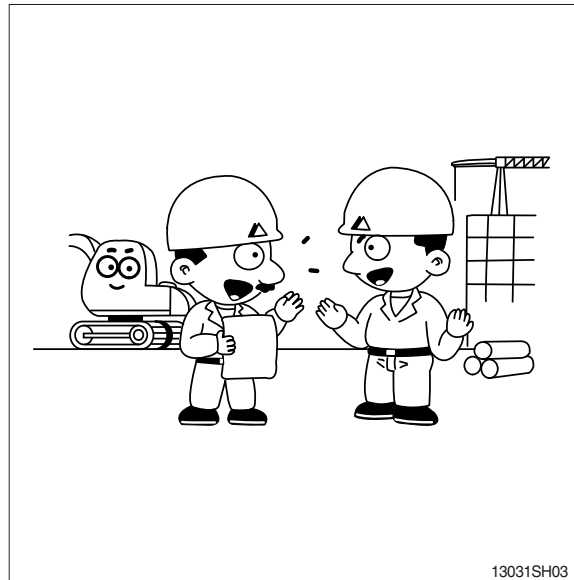

STEP 3. Inspect the machine

Before starting troubleshooting, check the machine for the daily maintenance points as shown in the operator's manual.

And also check the electrical system including batteries, as the troubles in the electrical system such as low battery voltage, loose connections and blown out fuses will result in malfunction of the controllers causing total operational failures of the machine.

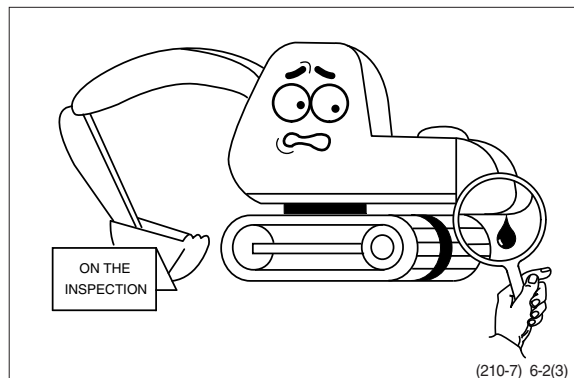

STEP 4. Inspect the trouble actually on the machine

In case that some trouble cannot be confirmed, obtain the details of the malfunction from the operator.

Also, check if there are any incomplete connections of the wire harnesses or not.

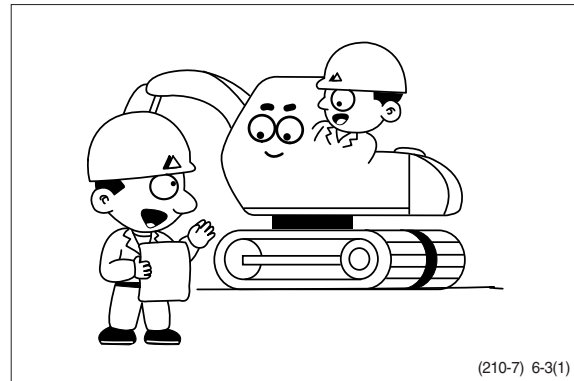

STEP 5. Perform troubleshooting

According to where the trouble parts are located, hydraulic & mechanical system part or electrical system part or mechatronics system part, perform troubleshooting the machine refer to the each system part's troubleshooting process diagram.

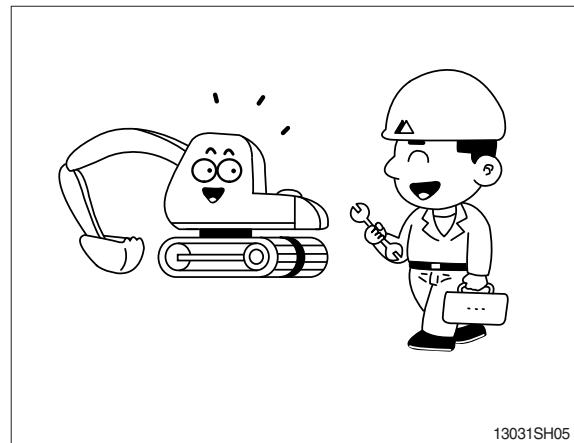

STEP 6. Trace a cause

Before reaching a conclusion, check the most susceptible causes again. Try to trace what the real cause of the trouble is.

Make a plan of the appropriate repairing procedure to avoid consequential malfunctions.

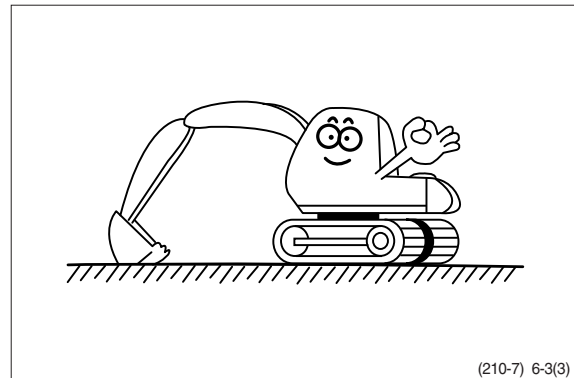

GROUP 2 HYDRAULIC AND MECHANICAL SYSTEM

1. INTRODUCTION

1) MACHINE IN GENERAL

(1) If even a minor fault is left intact and operation is continued, a fatal failure may be caused, entailing a large sum of expenses and long hours of restoration.

Therefore when even a small trouble occurs, do not rely on your intuition and experience, but look for the cause based on the troubleshooting principle and perform maintenance and adjustment to prevent major failure from occurring. Keep in mind that a fault results from a combination of different causes.

(2) The following lists up commonly occurring faults and possible causes with this machine. For the troubleshooting of the engine, refer to the coming troubleshooting and repair.

(3) When carrying out troubleshooting, do not hurry to disassemble the components. It will become impossible to find the cause of the problem.

(4) Ask user or operator the following.

- ① Was there any strange thing about machine before failure occurred?
- ② Under what conditions did the failure occur?
- ③ Have any repairs been carried out before the failure?

(5) Check before troubleshooting.

- ① Check oil and fuel level.
- ② Check for any external leakage of oil from components.
- ③ Check for loose or damage of wiring and connections.

2) MACHINE STATUS MONITORING ON THE CLUSTER

(1) The machine status such as the engine rpm, oil temperature, voltage and pressure etc. can be checked by this menu.

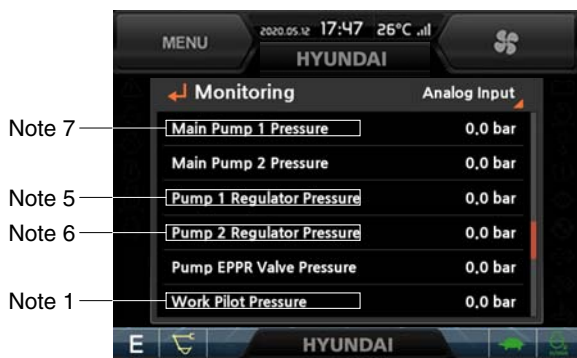

Analog 1



Analog 2

210A6HS01

(2) Specification

| No. | Description | Specification |
|--------|---------------------------|-----------------------------------|
| Note 1 | Work pilot pressure | 40 ⁺² ₀ bar |
| Note 2 | Swing pilot pressure | 0~40 bar |
| Note 3 | Boom up pilot pressure | 0~40 bar |
| Note 4 | Arm/bucket pilot pressure | 0~40 bar |
| Note 5 | Pump 1 regulator pressure | 0~50 bar |
| Note 6 | Pump 2 regulator pressure | 0~50 bar |
| Note 7 | Pump 1 pressure | 350 bar |

2. DRIVE SYSTEM

1) UNUSUAL NOISE COMES OUT OF PUMP CONNECTION

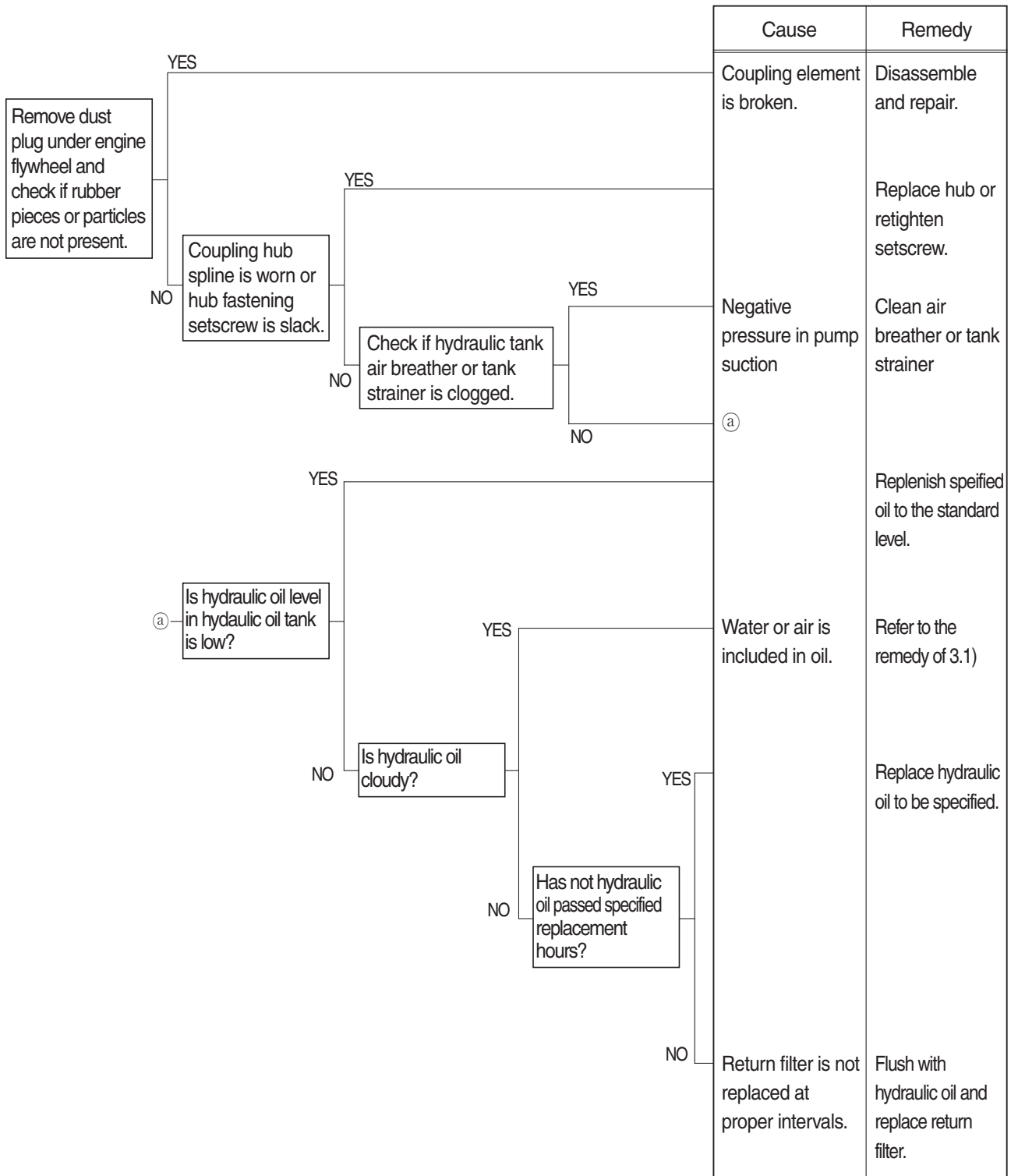

2) ENGINE STARTS BUT MACHINE DOES NOT OPERATE AT ALL

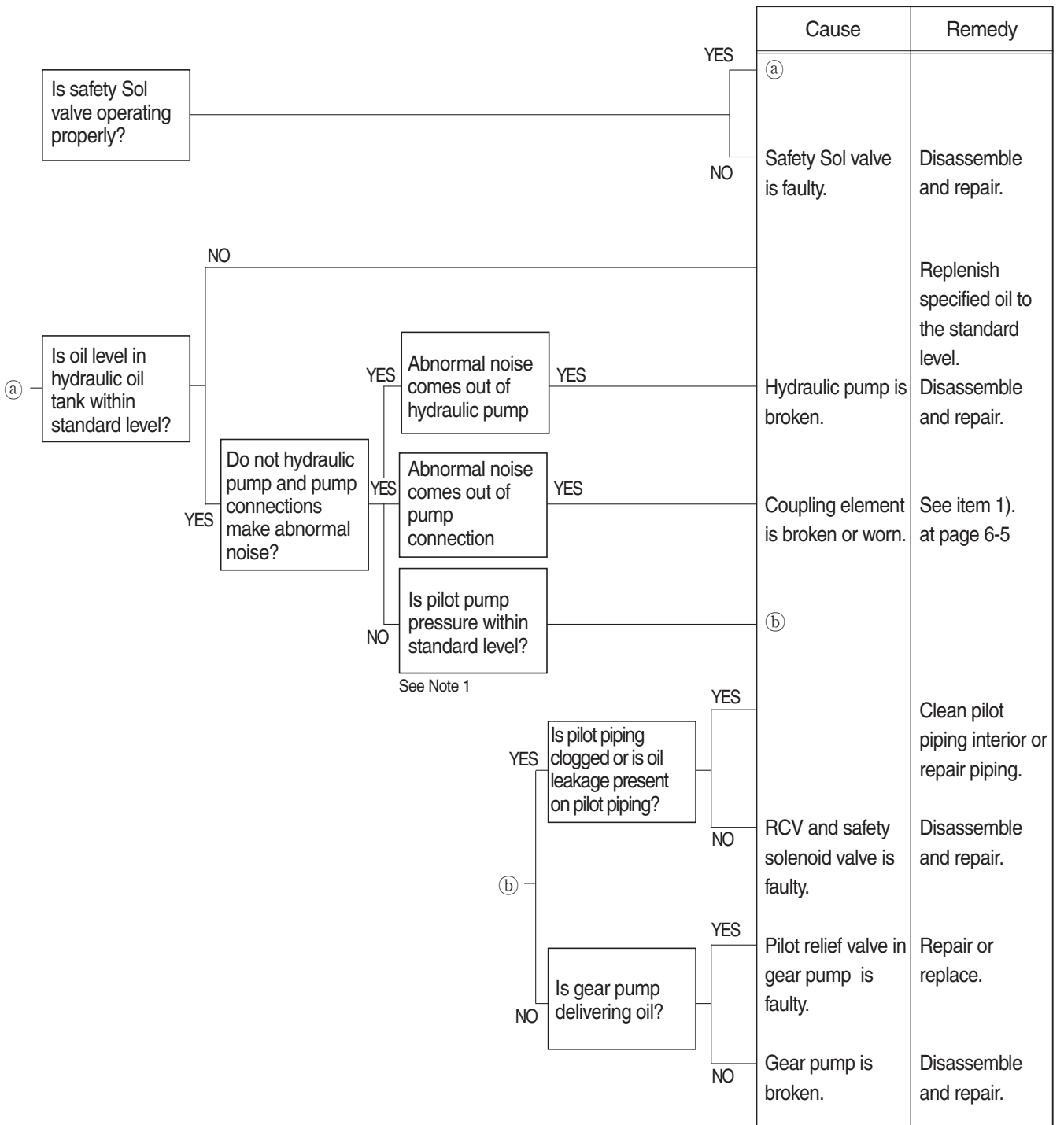

3. HYDRAULIC SYSTEM

1) HYDRAULIC OIL IS CLOUDY

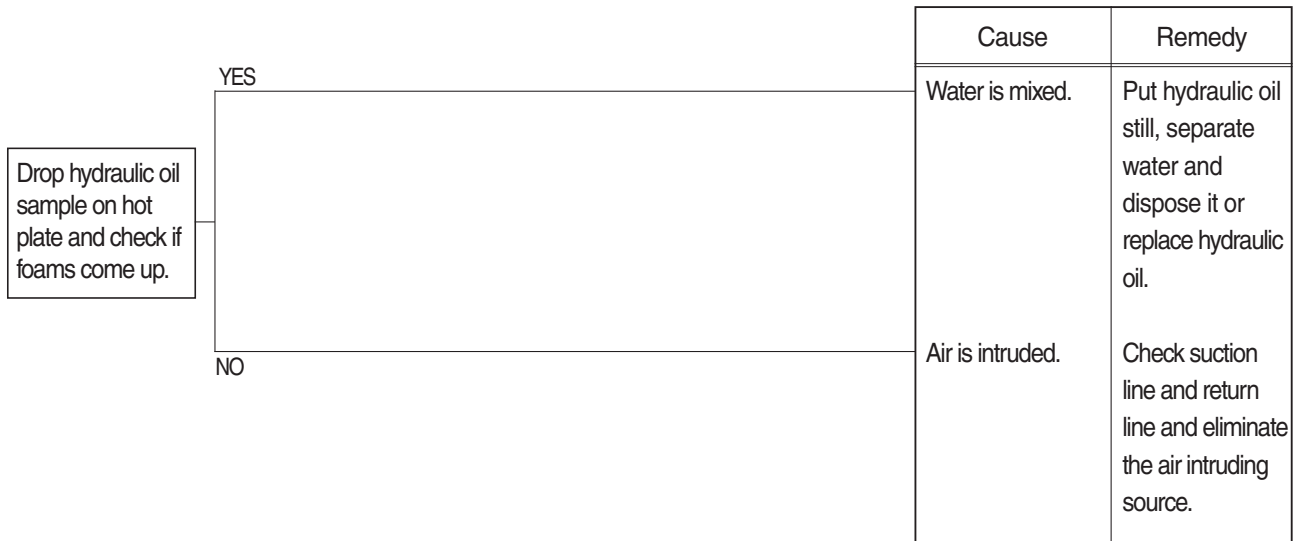

2) HYDRAULIC OIL TEMPERATURE HAS RISEN ABNORMALLY

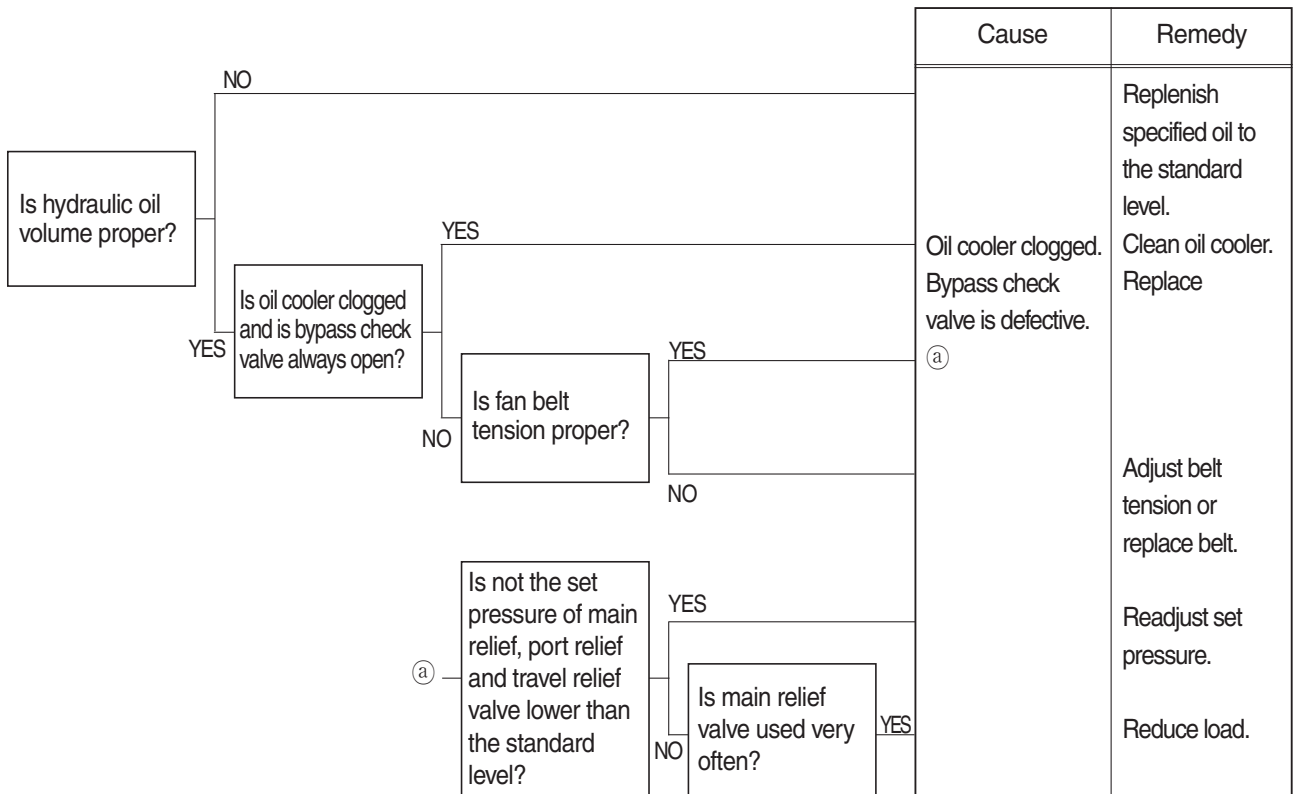

3) CAVITATION OCCURS WITH PUMP

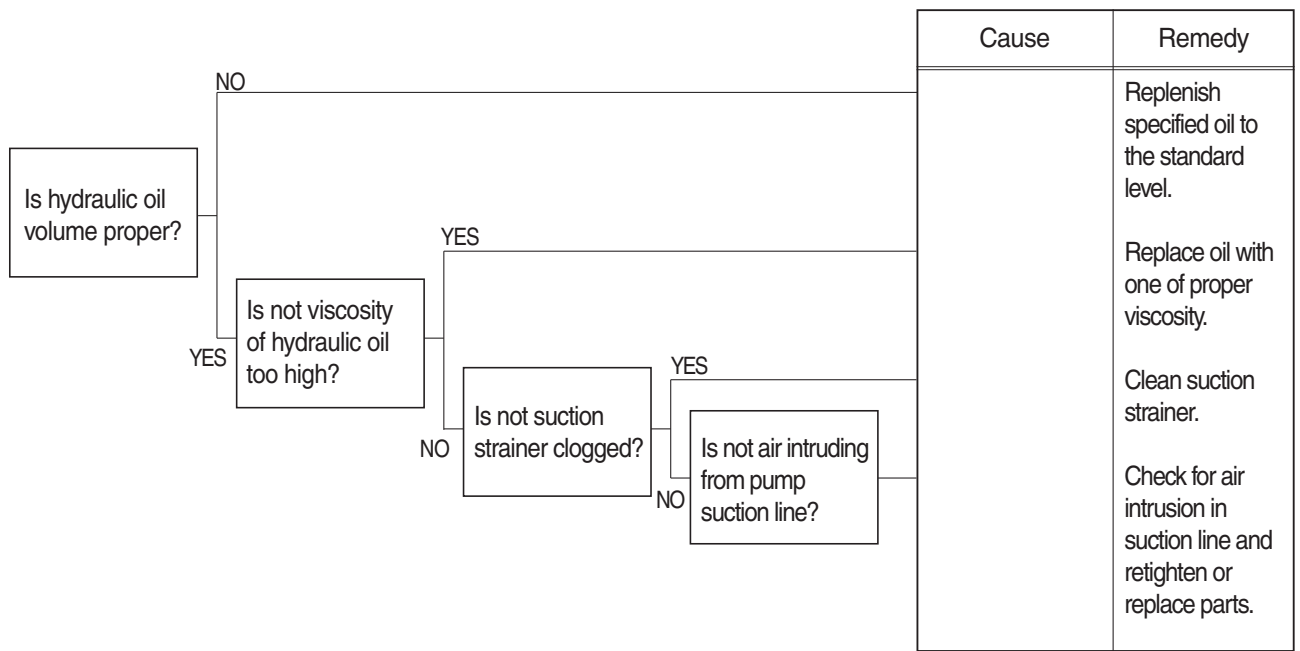

4) HYDRAULIC OIL IS CONTAMINATED

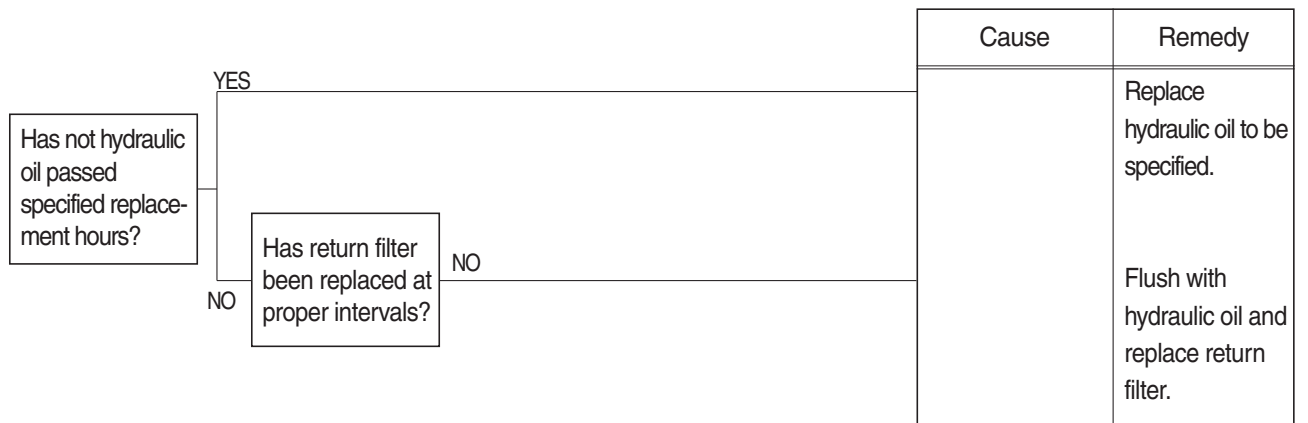

2) SWING SPEED IS LOW

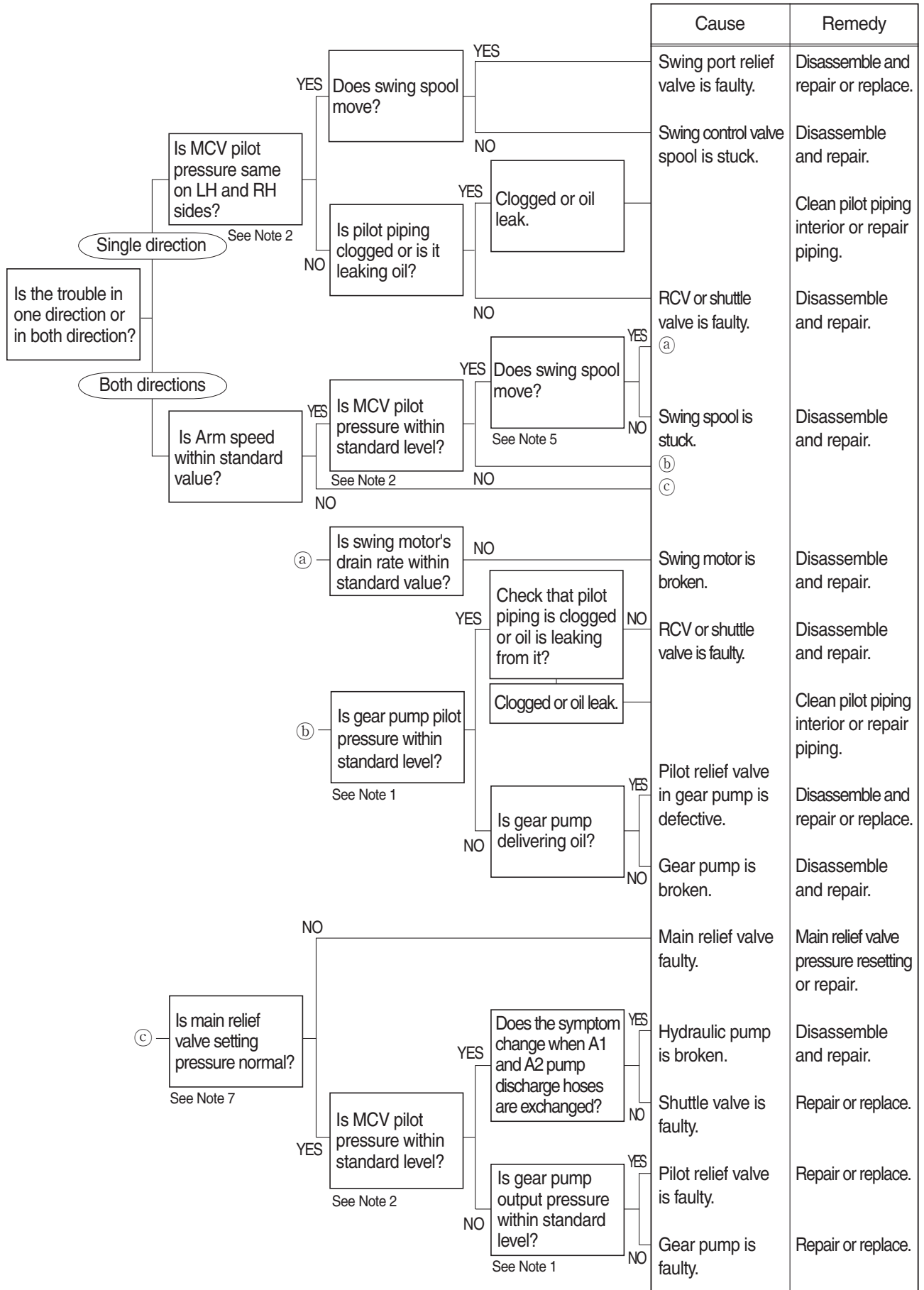

3) SWING MOTION IS IMPOSSIBLE IN ONE DIRECTION

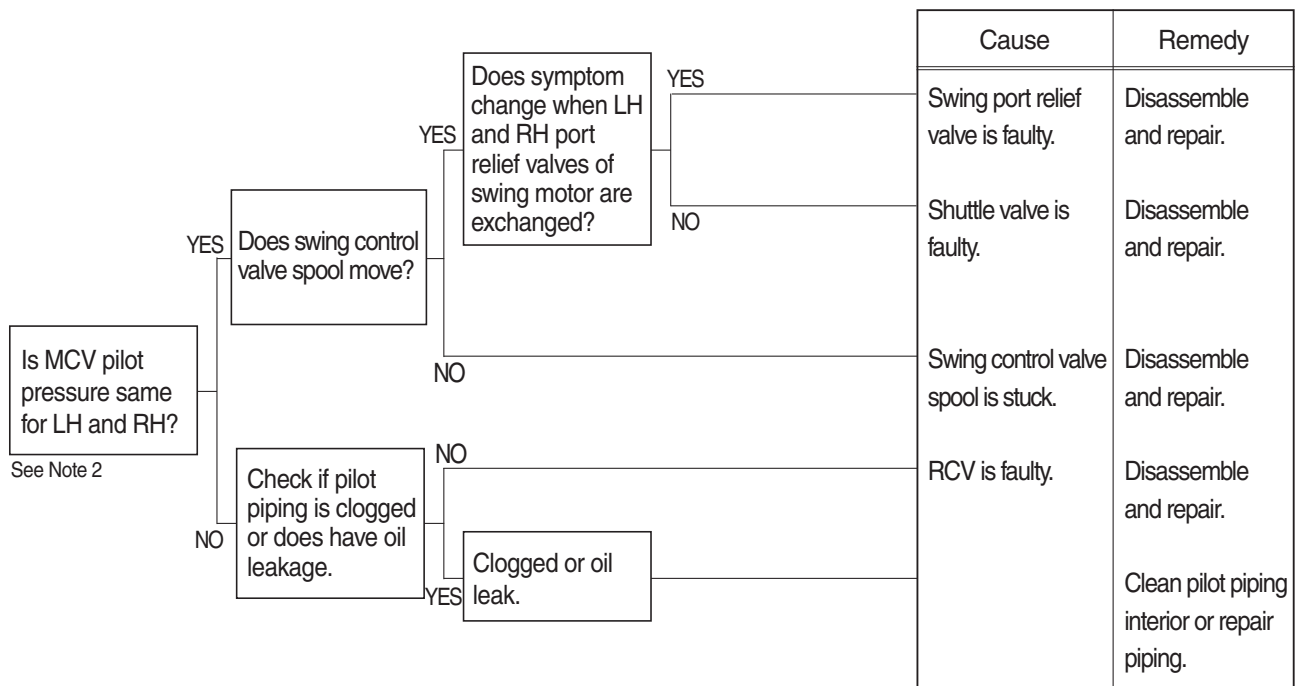

4) MACHINE SWINGS BUT DOES NOT STOP

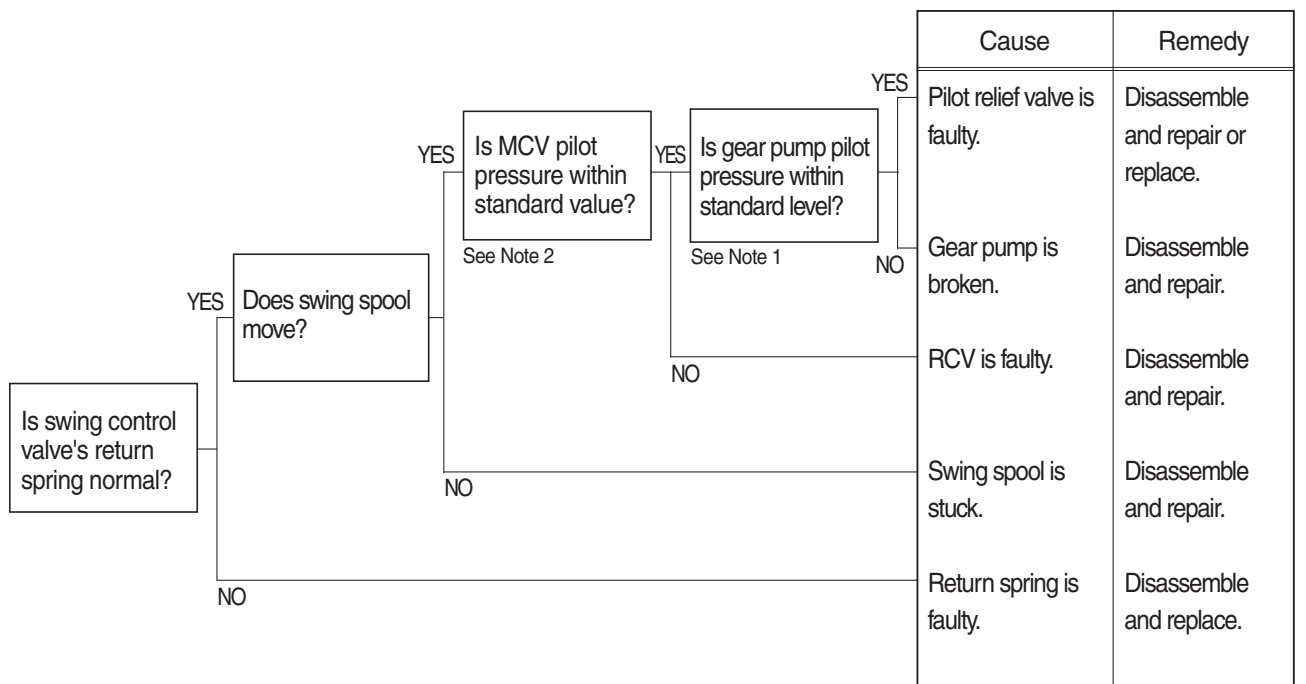

5) THE SWING UNIT DRIFTS WHEN THE MACHINE IS AT REST ON A SLOPE

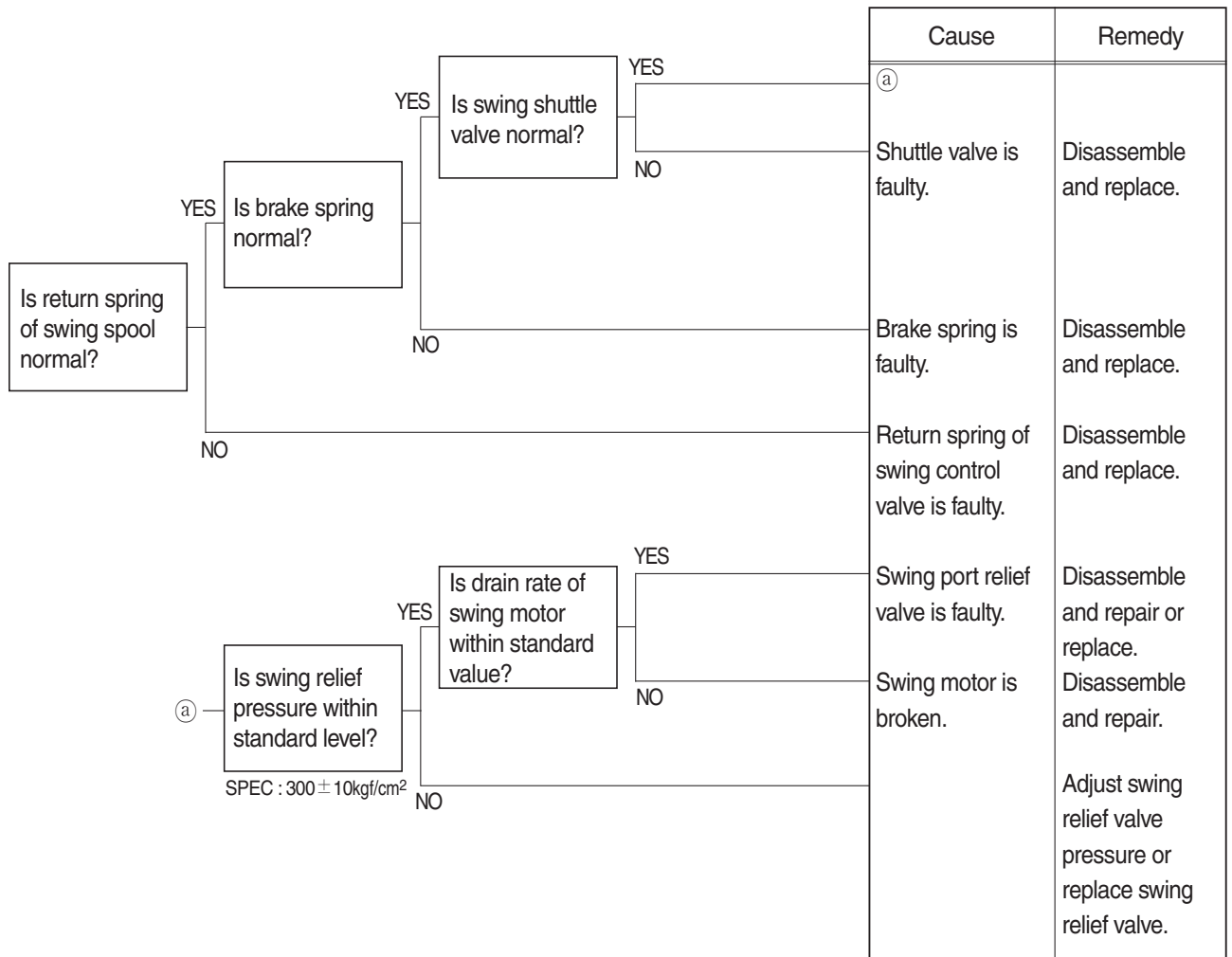

6) LARGE SHOCK OCCURS WHEN STOP SWINGING

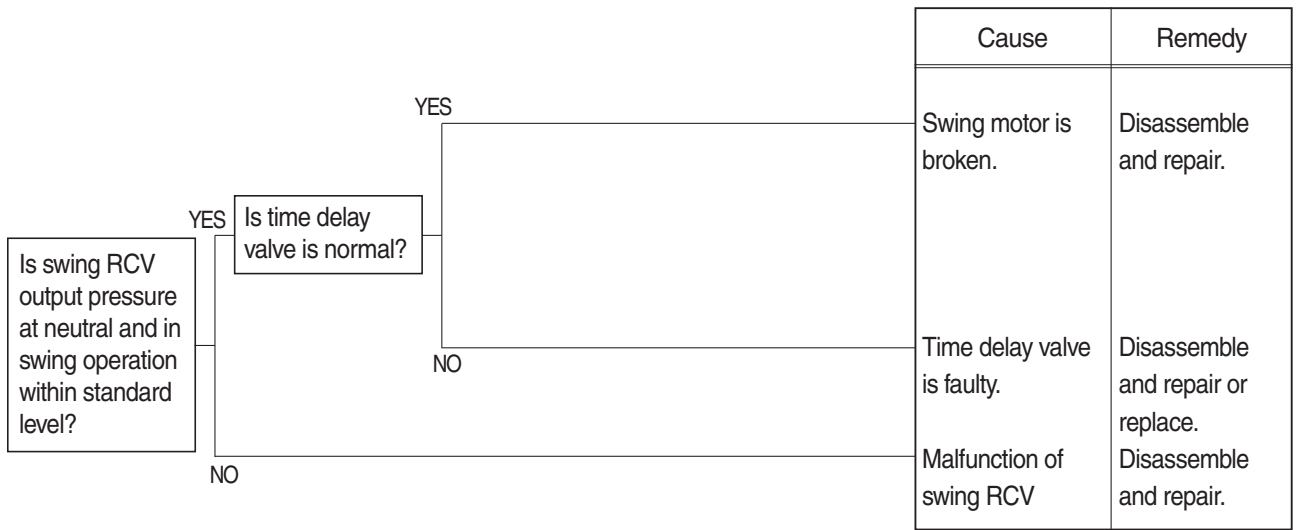

7) LARGE SOUND OCCURS WHEN STOP SWINGING

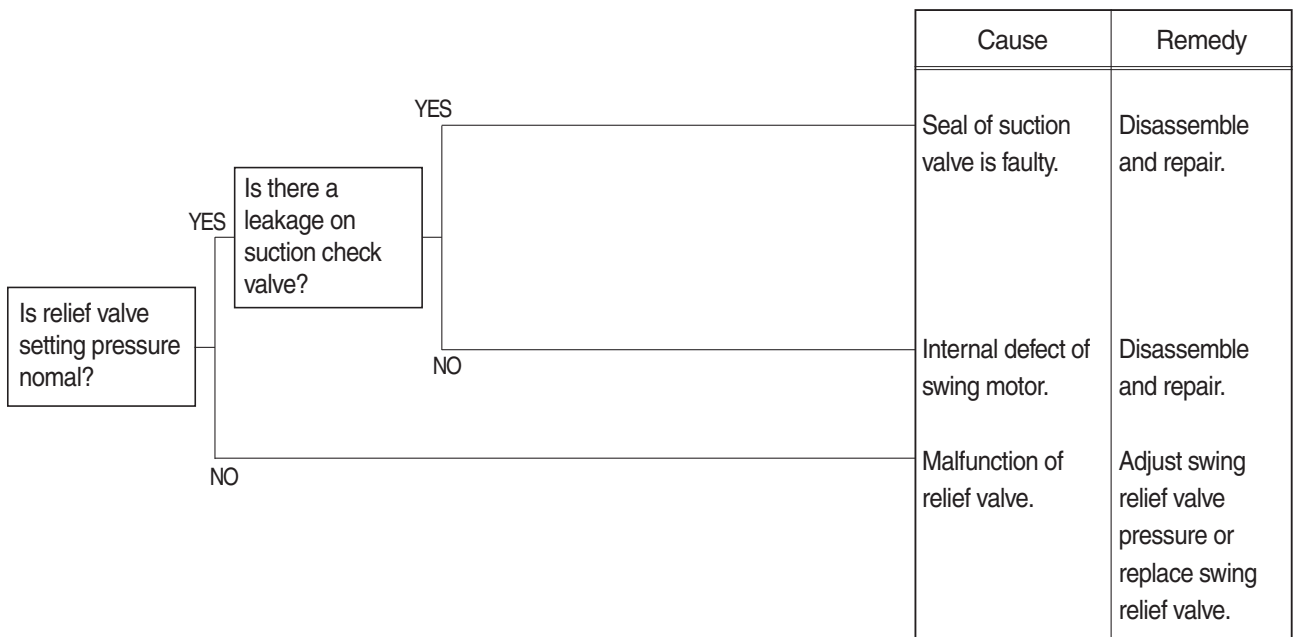

5. TRAVEL SYSTEM

1) TRAVEL DOES NOT FUNCTION AT ALL ON ONE SIDE

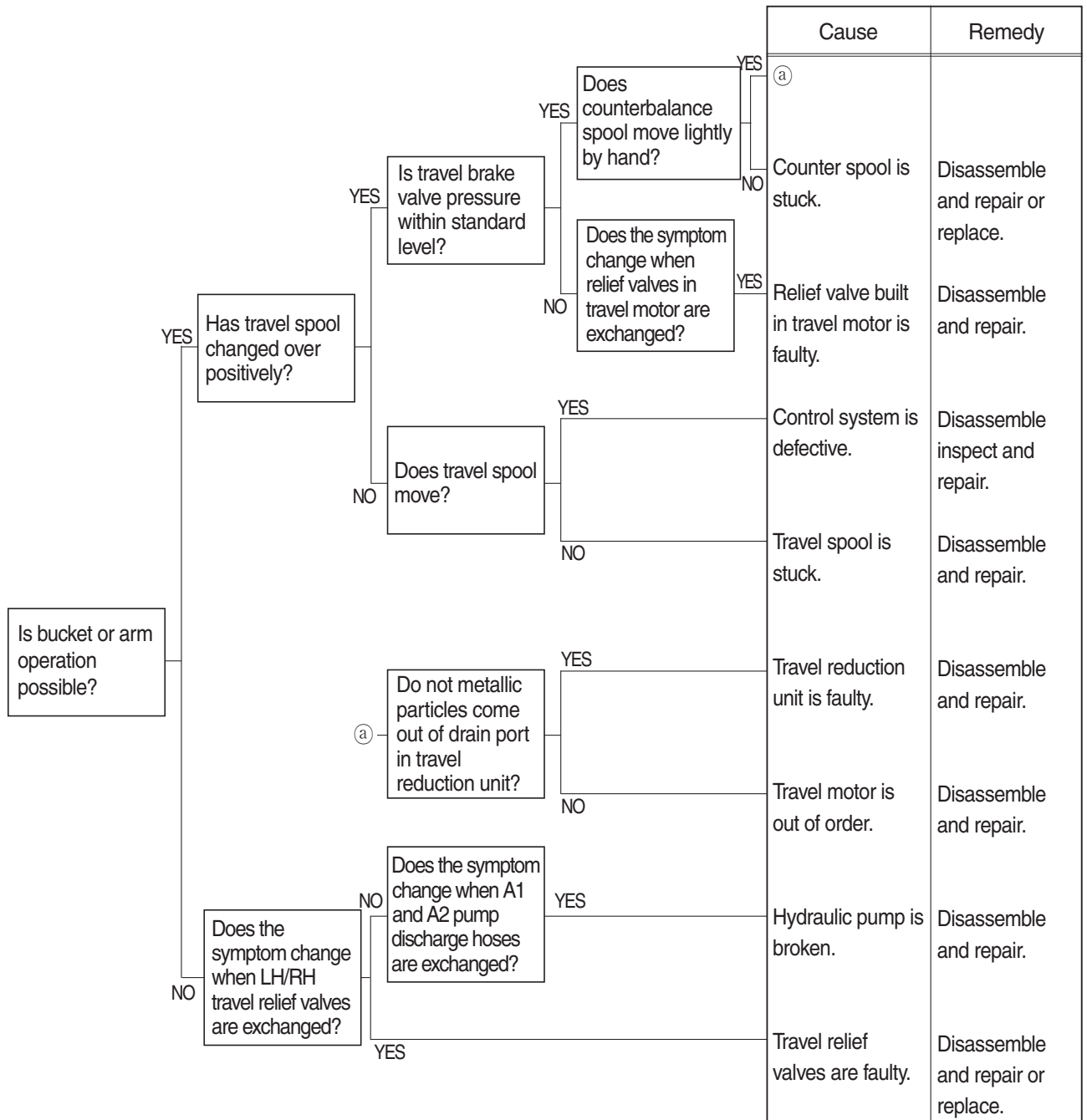

2) SPEED ON ONE SIDE FALLS AND THE MACHINE CURVES

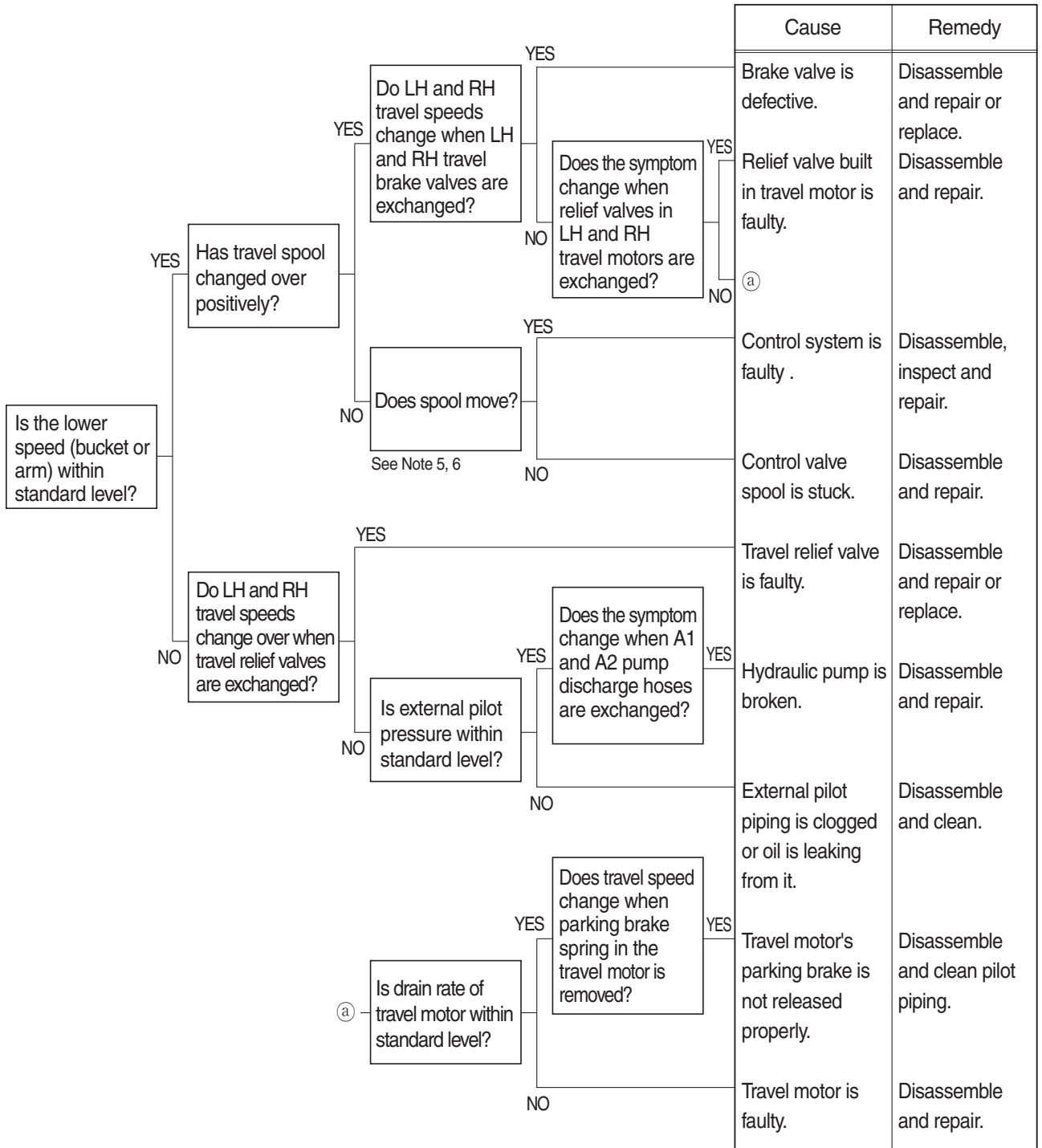

3) MACHINE DOES NOT STOP ON A SLOPE

Machine is pulled forward as sprocket rotates during digging operation.

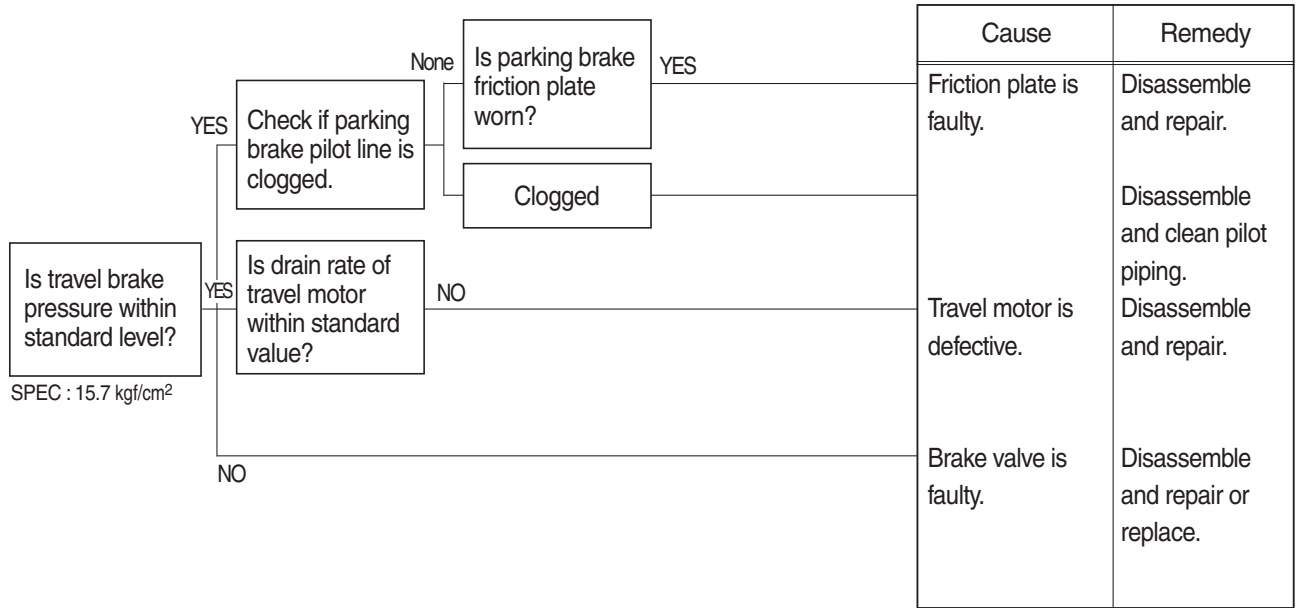

4) LH AND RH TRAVEL MOTIONS ARE IMPOSSIBLE

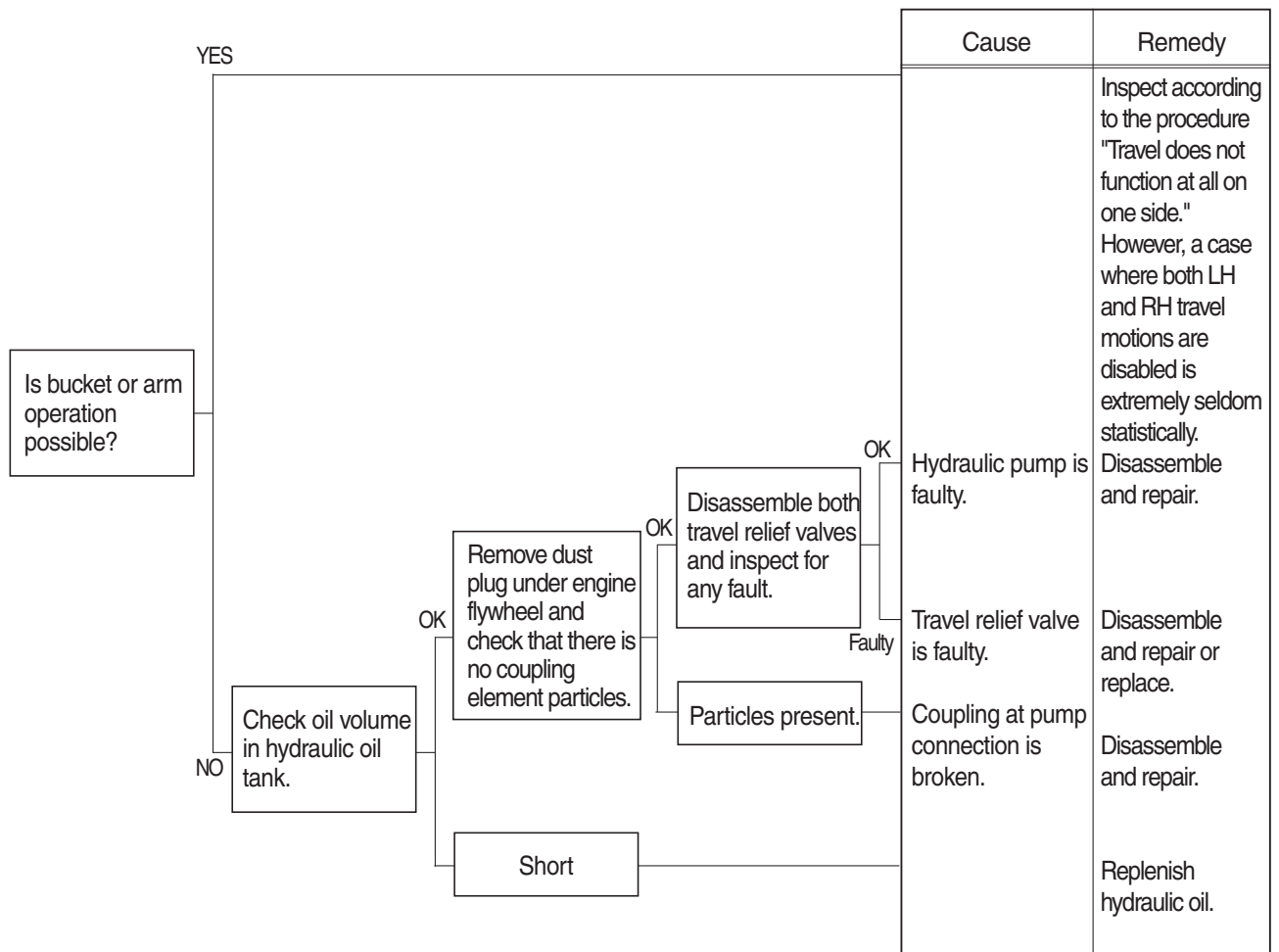

5) TRAVEL ACTION IS POWERLESS (travel only)

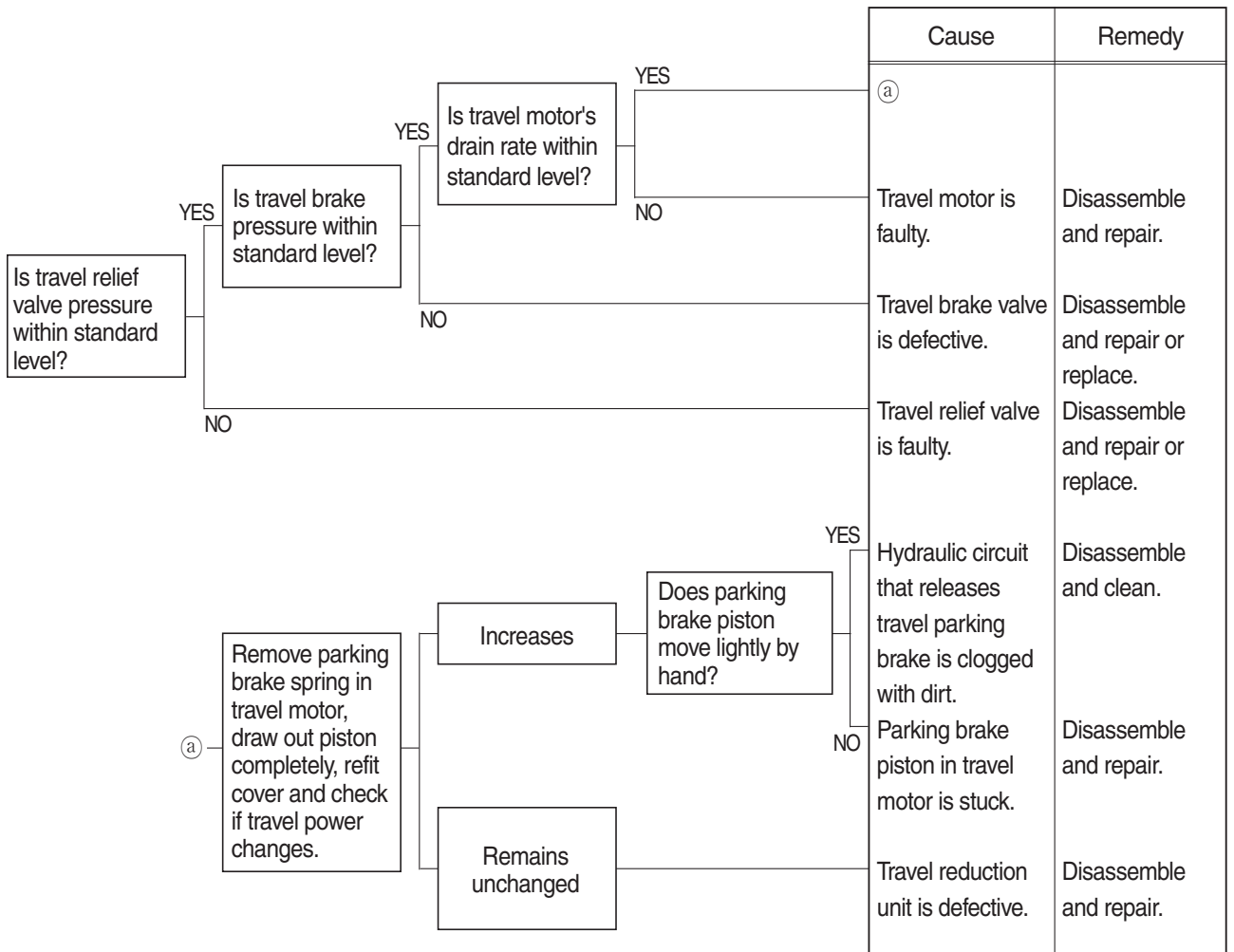

6) MACHINE RUNS RECKLESSLY ON A SLOPE



7) MACHINE MAKES A CURVED TRAVEL OR DOES NOT TRAVEL AT ALL WHEN TRAVEL AND ATTACHMENT OPERATIONS ARE EXECUTED AT THE SAME TIME

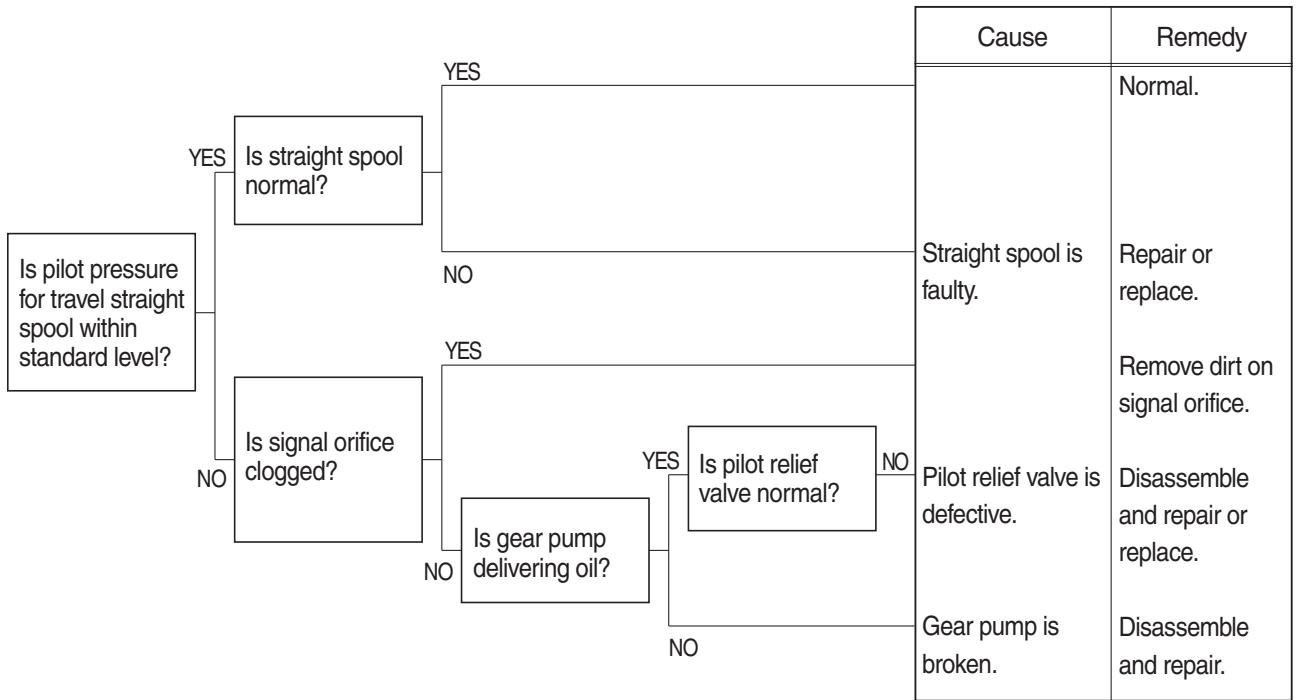

6. ATTACHMENT SYSTEM

1) BOOM OR ARM ACTION IS IMPOSSIBLE AT ALL

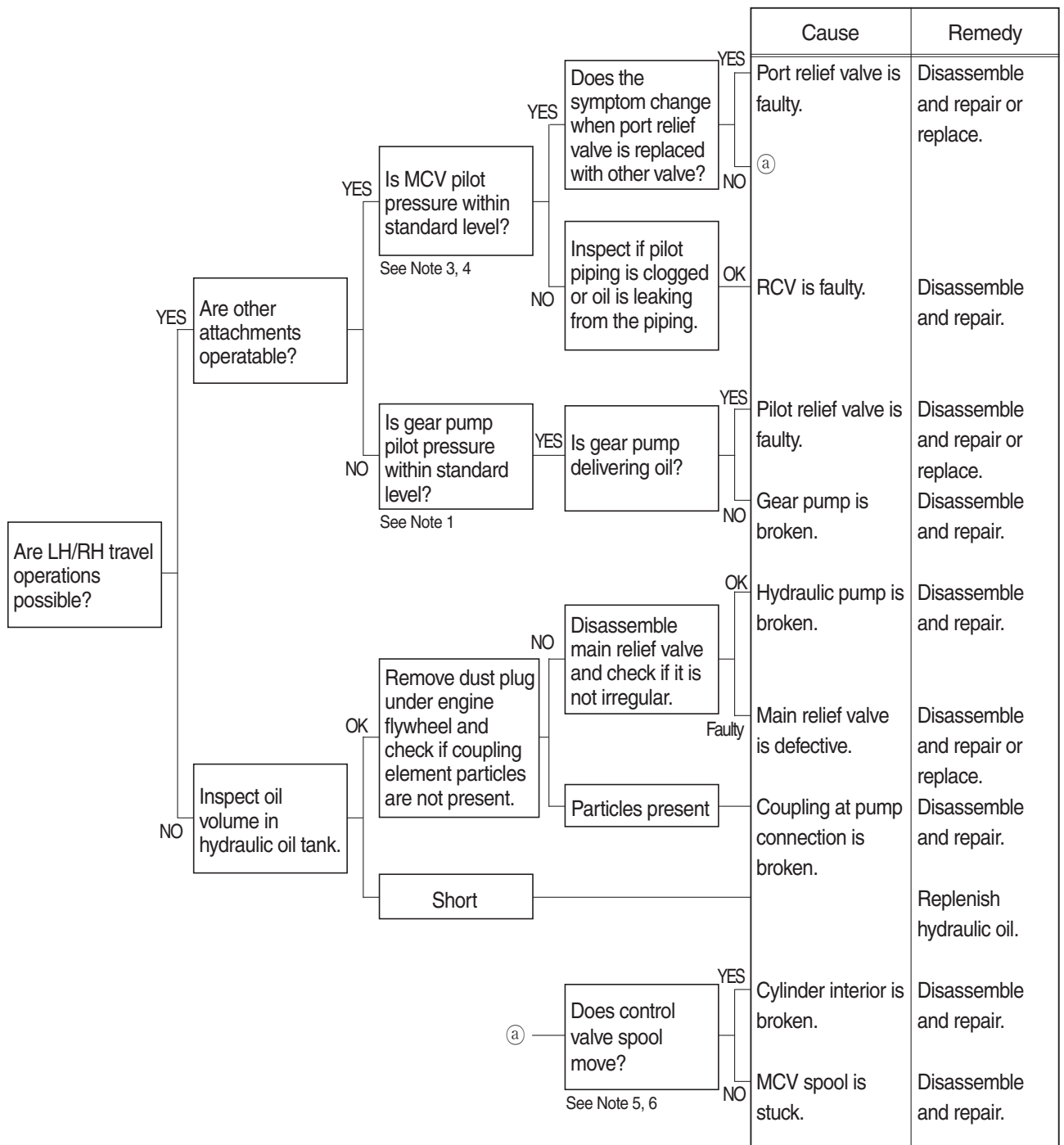

2) BOOM, ARM OR BUCKET SPEED IS LOW

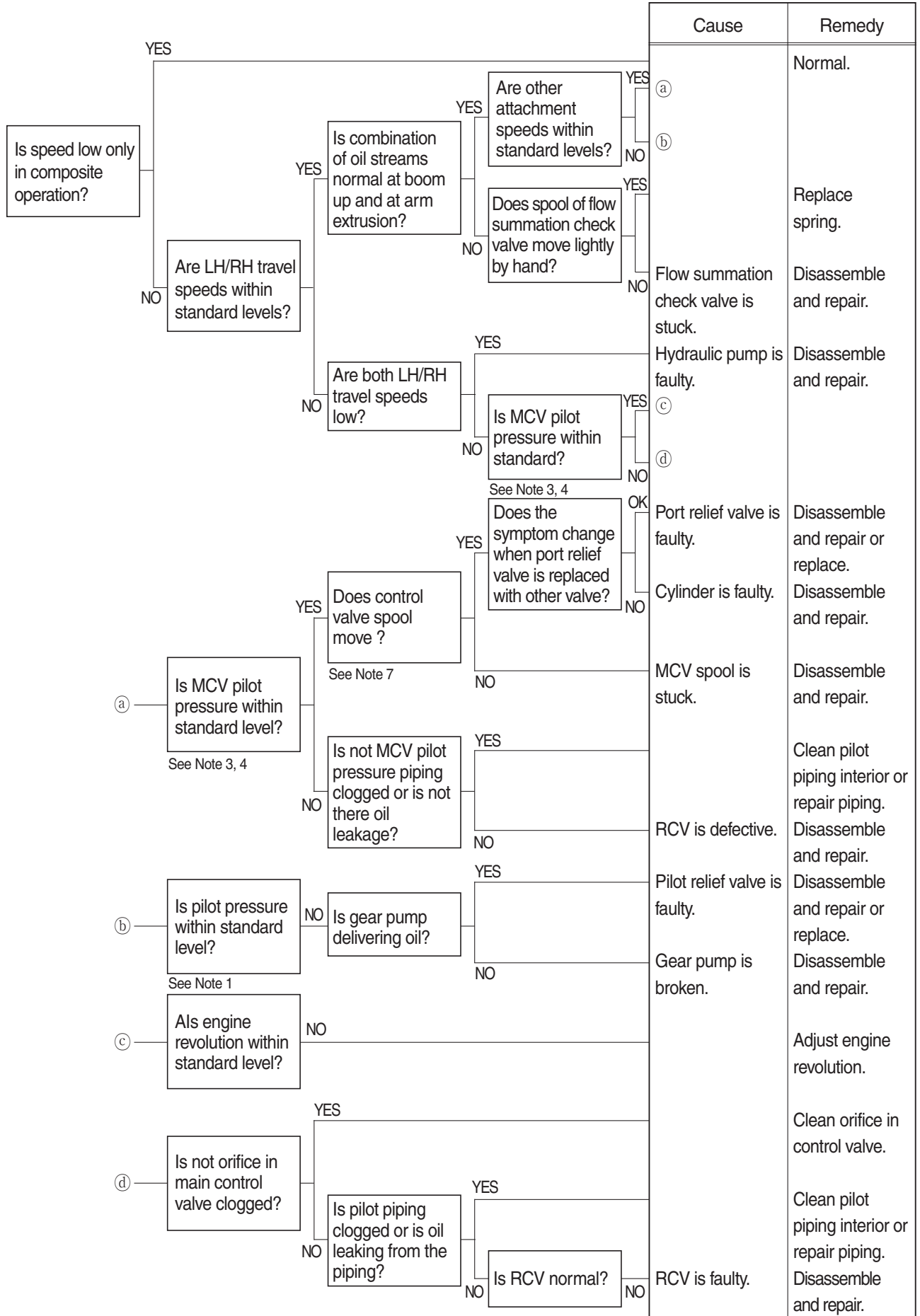

3) BOOM, ARM OR BUCKET CYLINDER EXTENDS OR CONTRACTS ITSELF AND ATTACHMENT FALLS

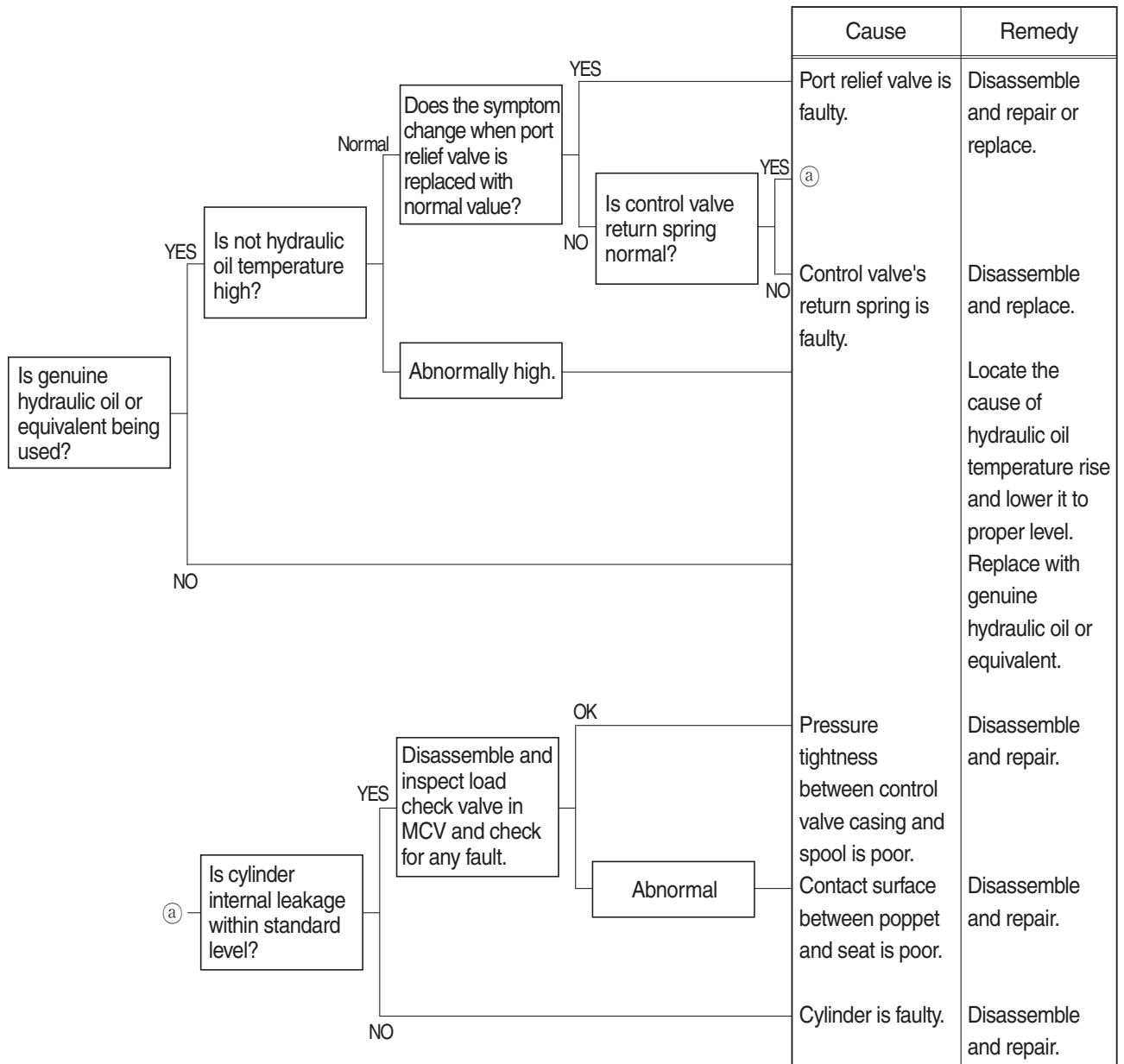

4) BOOM, ARM OR BUCKET POWER IS WEAK

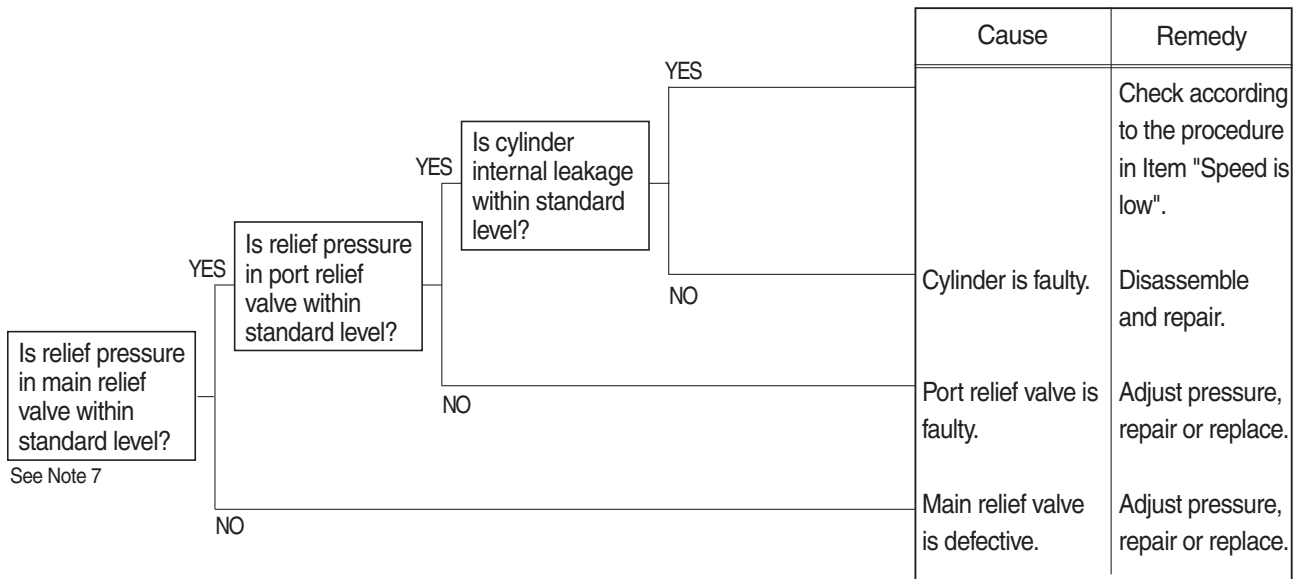

5) ONLY BUCKET OPERATION IS TOTALLY IMPOSSIBLE

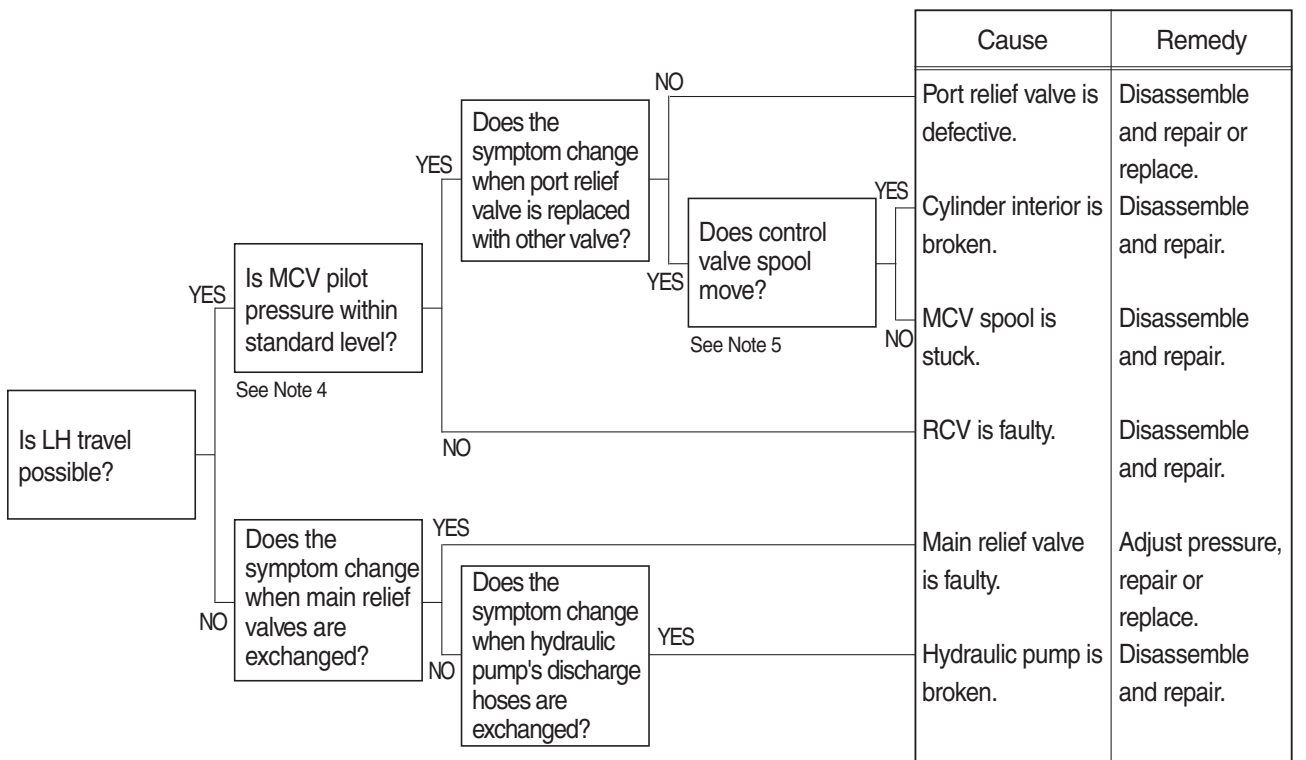

6) BOOM MAKES A SQUEAKING NOISE WHEN BOOM IS OPERATED

| | | Cause | Remedy |
|--|-----|--------------------------------------|--|
| <div style="border: 1px solid black; padding: 5px; width: fit-content;"> Is boom foot pin greased sufficiently? </div> | YES | | Frictional noise occurs between the sliding faces of boom cylinder's oil seal and boom proper. ※ Frictional noise will disappear if they are kept used. |
| | NO | Boom foot pin has run out of grease. | Supply grease to it. ※ If seizure is in an initial stage, supply sufficient grease. If seizure is in a grown state, correct it by paper lapping or with an oil stone. |

7) TIME LAG OF MACHINE WORKING IS LARGE.

| | | Cause | Remedy |
|---|-----|----------------------------------|-------------------------|
| <div style="border: 1px solid black; padding: 5px; width: fit-content;"> Is overload relief valve for each spool working properly? </div> | YES | | Refer to 2) |
| | NO | Overload relief valve is faulty. | Disassemble and repair. |

※ HOW TO CHECK INTERNAL BOOM CYLINDER LEAKAGE

1. Lower the bucket teeth to the ground with bucket cylinder fully retracted and arm cylinder rod retracted almost in full.

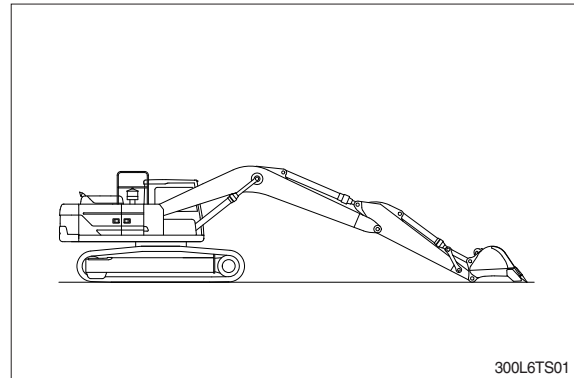

2. Disconnect hose (A) from rod side of boom cylinder and drain oil from cylinders and hose. (put cups on piping and hose ends)

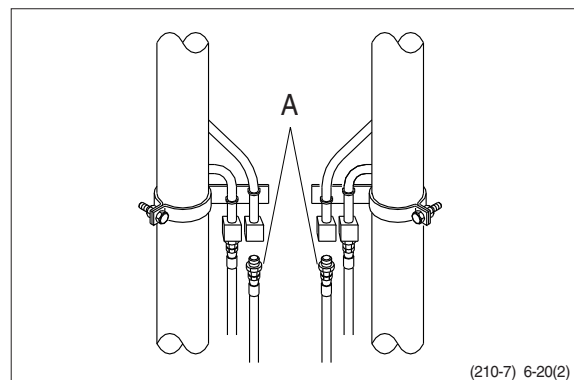

3. Raise bucket OFF the ground by retracting the arm cylinder rod.

If oil leaks from piping side and boom cylinder rod is retracted there is an internal leak in the cylinder.

If no oil leaks from piping side and boom cylinder rod is retracted, there is an internal leak in the control valve.

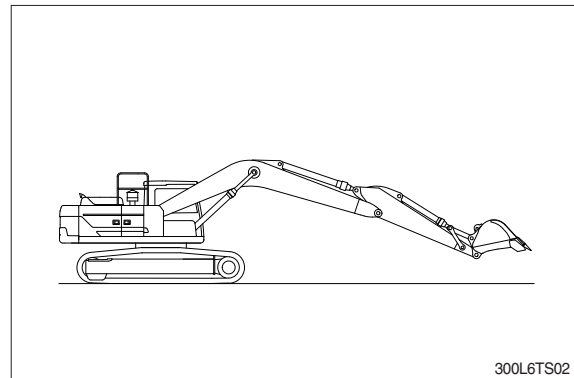

GROUP 3 ELECTRICAL SYSTEM

1. WHEN STARTING SWITCH IS TURNED ON, CLUSTER DISPLAY DOES NOT APPEAR

- Before disconnecting the connector, always turn the starting switch OFF.
- Before carrying out below procedure, check all the related connectors are properly inserted and short of fuse No. 11, 16.
- After checking, insert the disconnected connectors again immediately unless otherwise specified.

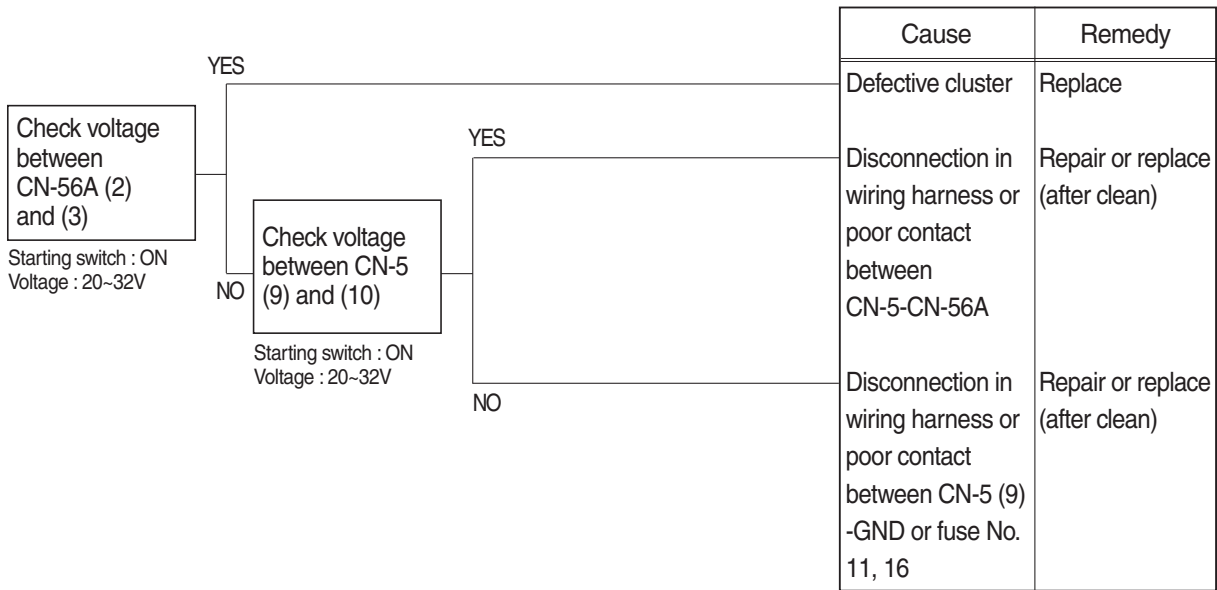

Check voltage

| | |
|-----|--------|
| YES | 20~32V |
| NO | 0V |

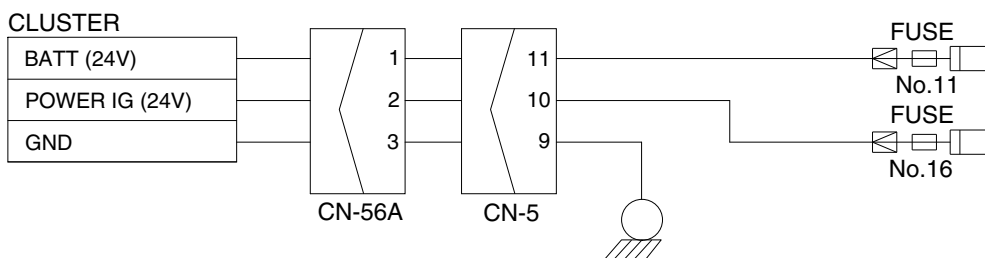

160A6ES01

2. COMMUNICATION ERROR FLASHES ON THE CLUSTER (HCESPN 840, FMI 2)

- Before disconnecting the connector, always turn the starting switch OFF.
- Before carrying out below procedure, check all the related connectors are properly inserted.
- After checking, insert the disconnected connectors again immediately unless otherwise specified.

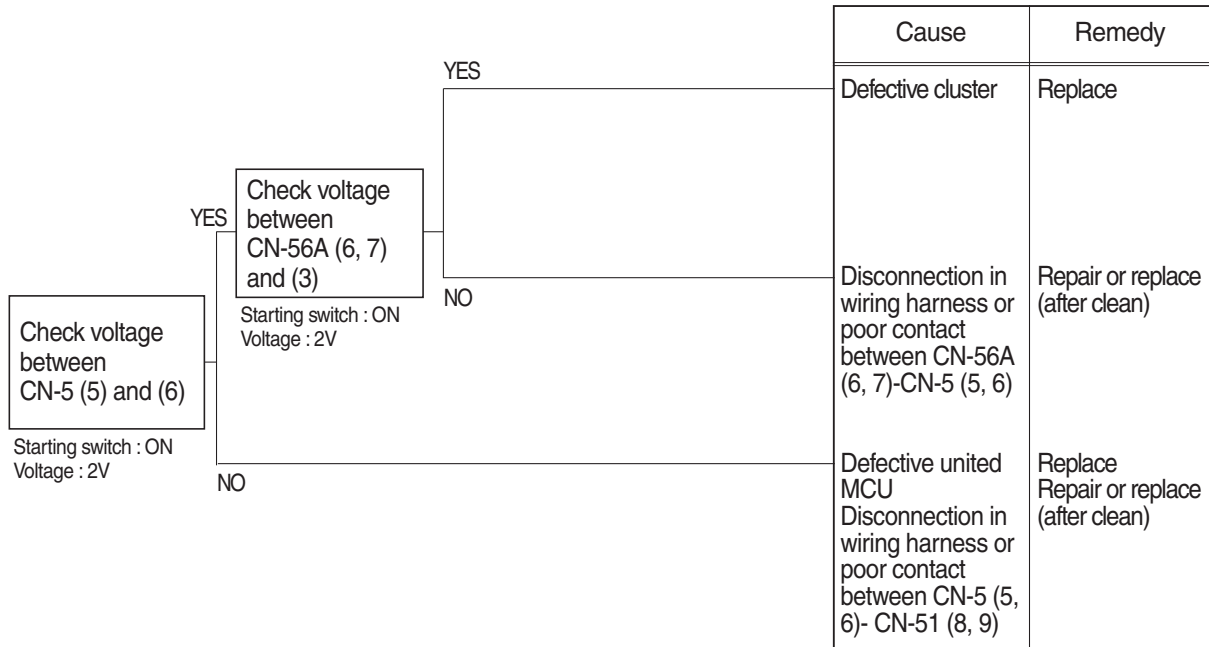

Check voltage

| | |
|-----|----|
| YES | 2V |
| NO | 0V |

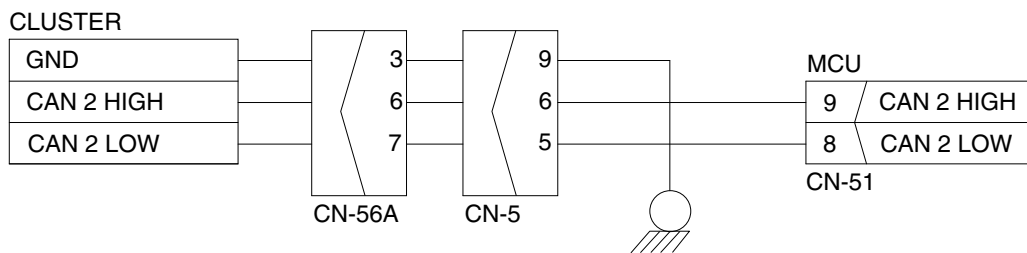

3. BATTERY CHARGING WARNING LAMP LIGHTS UP (Starting switch : ON)

- Before disconnecting the connector, always turn the starting switch OFF.
- Before carrying out below procedure, check all the related connectors are properly inserted.
- After checking, insert the disconnected connectors again immediately unless otherwise specified.

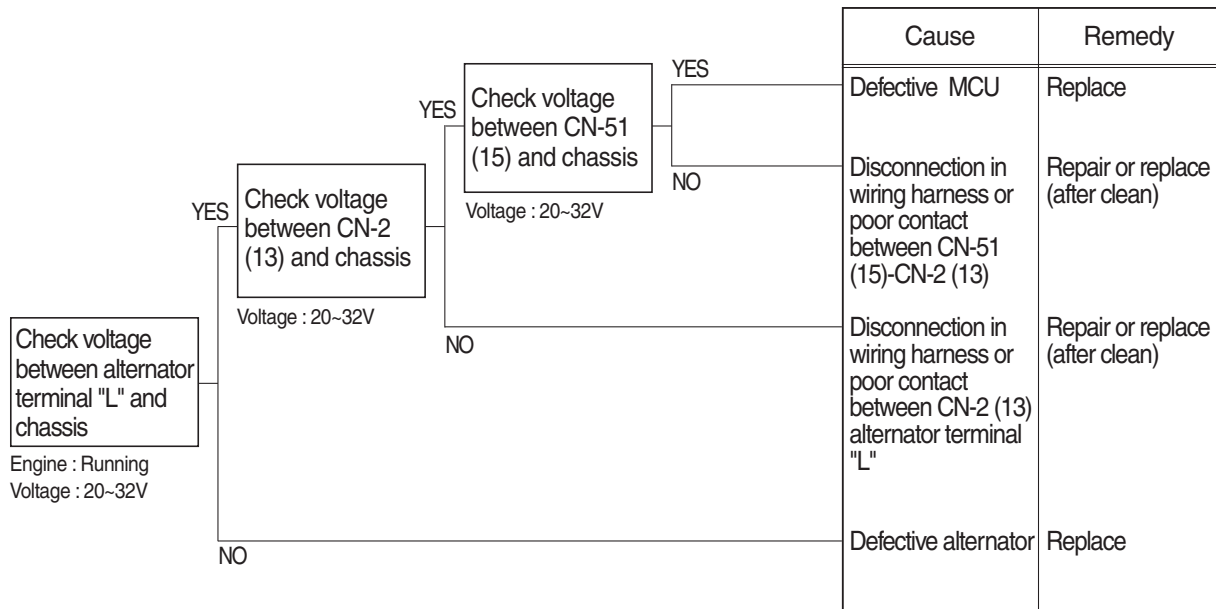

Check voltage

| | |
|-----|--------|
| YES | 20~32V |
| NO | 0V |

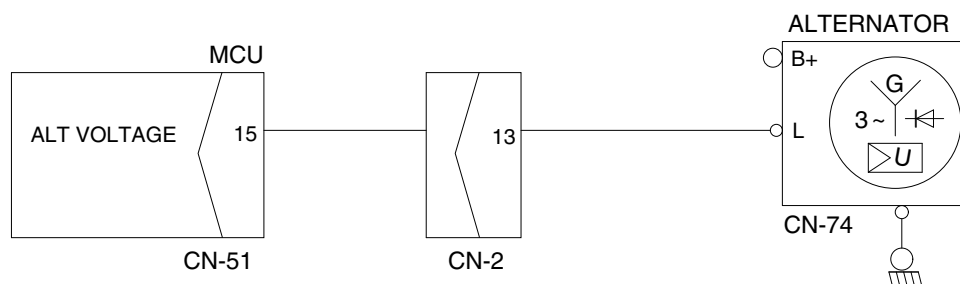

160A6ES03

4. WHEN COOLANT OVERHEAT WARNING LAMP LIGHTS UP (engine is started)

- Before disconnecting the connector, always turn the starting switch OFF.
- Before carrying out below procedure, check all the related connectors are properly inserted.
- After checking, insert the disconnected connectors again immediately unless otherwise specified.

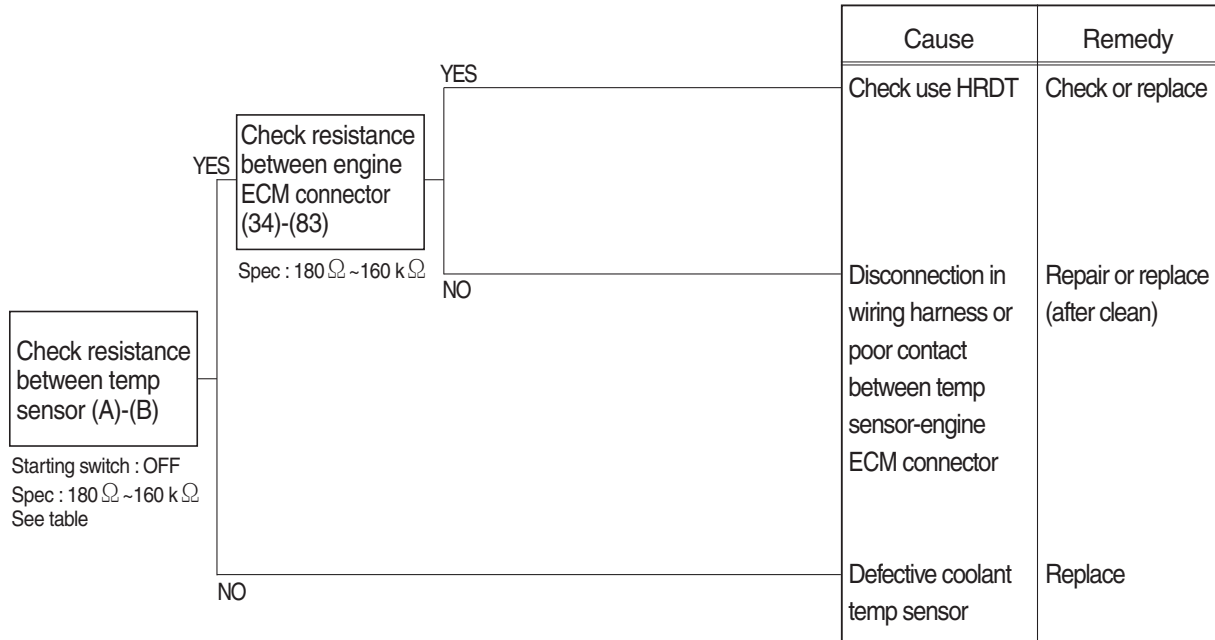

Check Table

| Temperature (°C) | 0 | 25 | 50 | 80 | 95 |
|------------------|-------|----------|---------|---------|---------|
| Resistance (kΩ) | 30~37 | 9.3~10.7 | 3.2~3.8 | 1.0~1.3 | 0.7~0.8 |

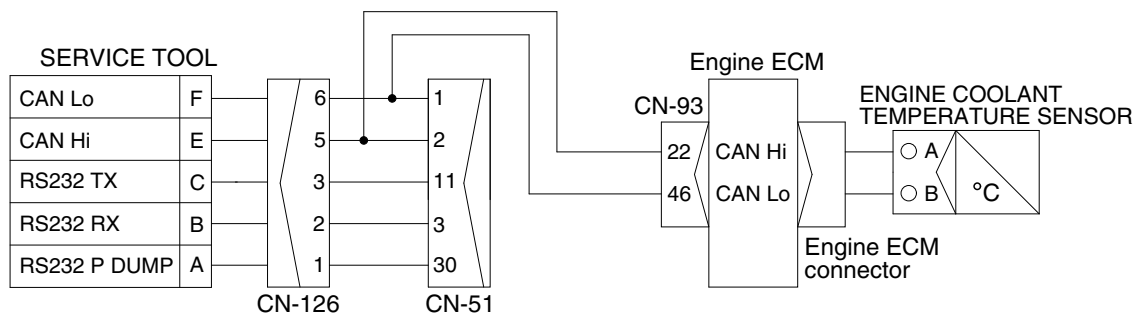

160A6ES04

5. WHEN AIR CLEANER WARNING LAMP LIGHTS UP (engine is started)

- Before disconnecting the connector, always turn the starting switch OFF.
- Before carrying out below procedure, check all the related connectors are properly inserted.
- After checking, insert the disconnected connectors again immediately unless otherwise specified.

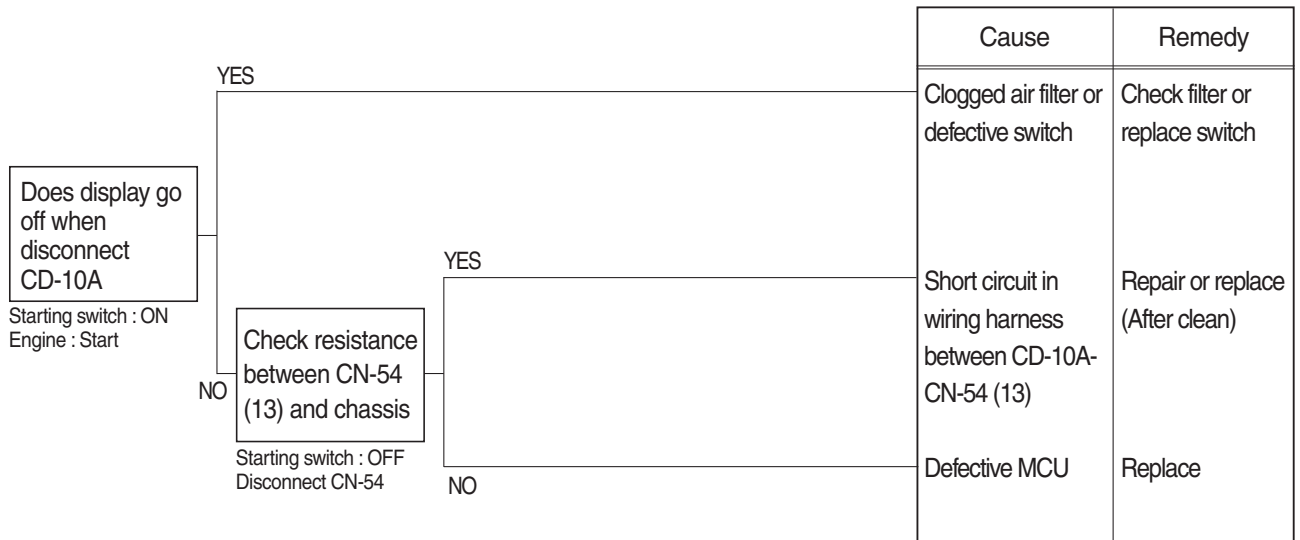

Check resistance

| | |
|-----|---------|
| YES | MAX 1Ω |
| NO | MIN 1MΩ |

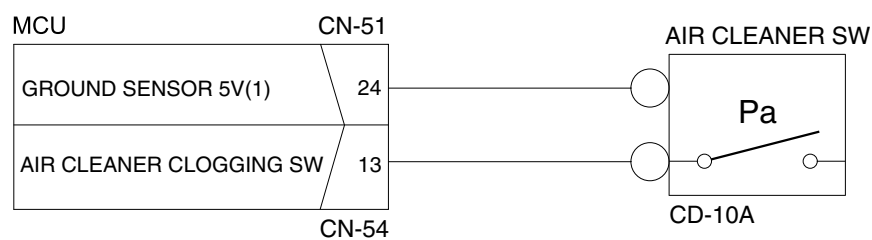

160A6ES06

6. WHEN ENGINE OIL PRESSURE WARNING LAMP LIGHTS UP (engine is started)

- Before disconnecting the connector, always turn the starting switch OFF.
- Before carrying out below procedure, check all the related connectors are properly inserted.
- After checking, insert the disconnected connectors again immediately unless otherwise specified.

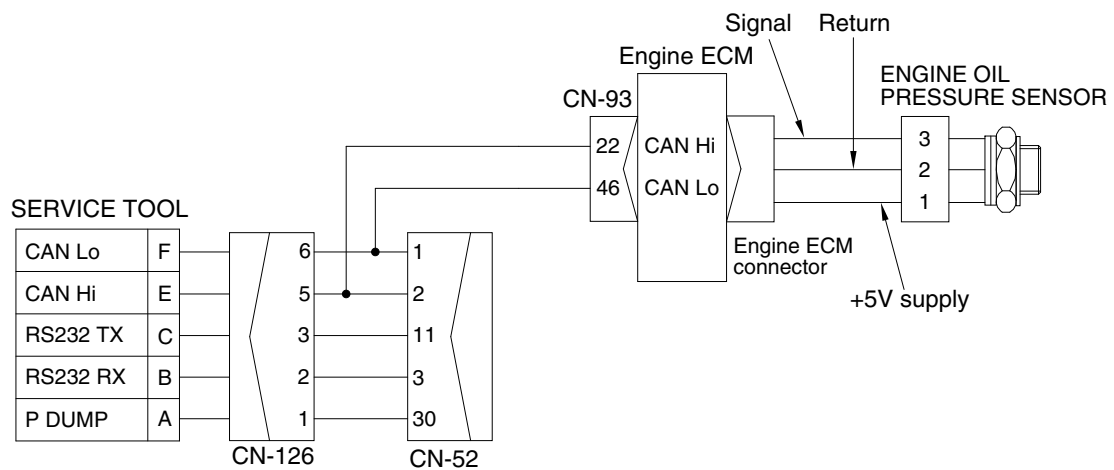
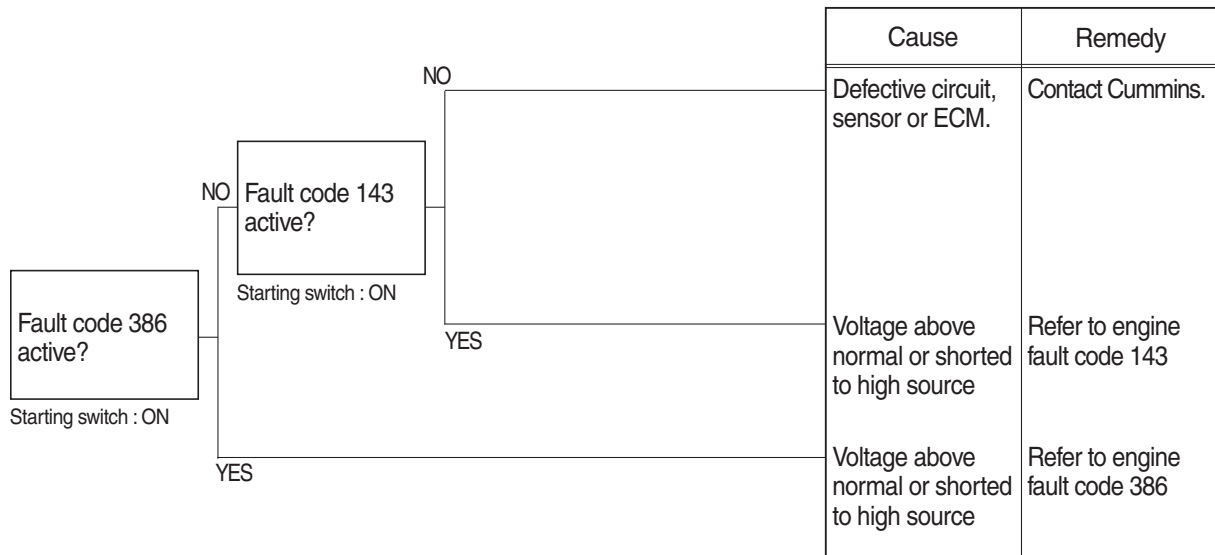

160A6ES07

7. WHEN HYDRAULIC OIL TEMPERATURE WARNING LAMP LIGHTS UP (engine is started)

- Before disconnecting the connector, always turn the starting switch OFF.
- Before carrying out below procedure, check all the related connectors are properly inserted.
- After checking, insert the disconnected connectors again immediately unless otherwise specified.

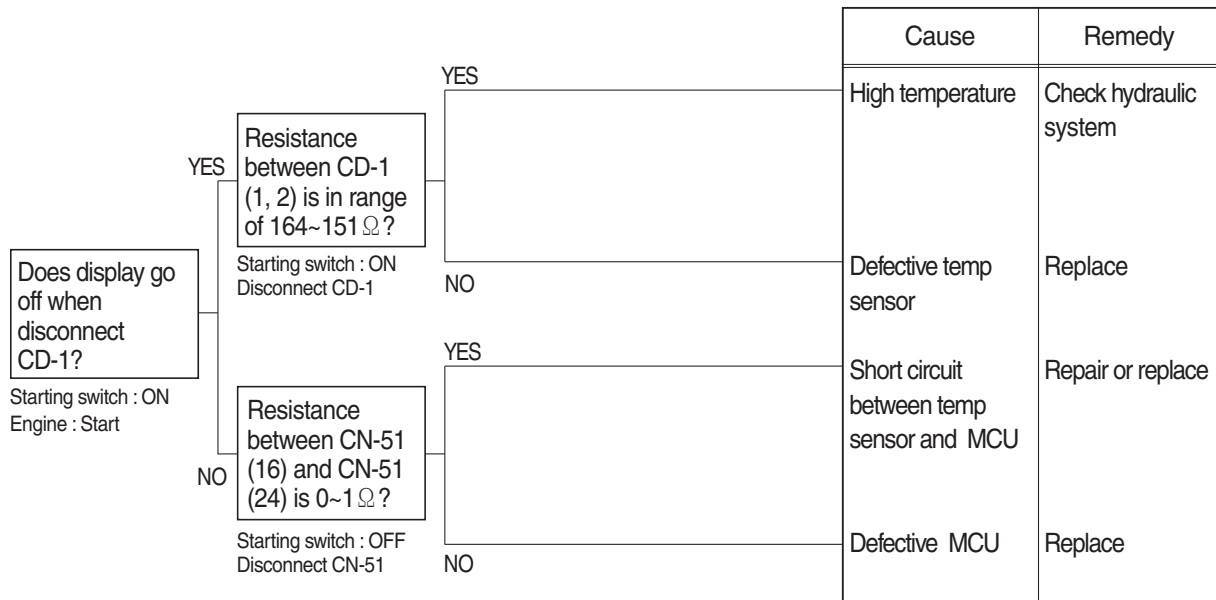

Check Table

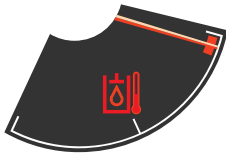

| | | | | | | | | | |
|------------------|-----------------|----------------|---------------|---------------|----------------|-----------------|-----------------|-----------------|-----------------|
| Temperature (°C) | ~ -30 | ~ -10 | ~ 0 | ~ 40 | ~ 70 | ~ 80 | ~ 90 | ~ 100 | 105~ |
| Resistance (kΩ) | 22.22 ~31.78 | 8.16 ~10.74 | 5.18 ~ 6.6 | 1.06 ~1.28 | 0.39 ~0.476 | 0.322 ~0.298 | 0.243 ~0.219 | 0.185 ~0.167 | 0.164 ~0.151 |

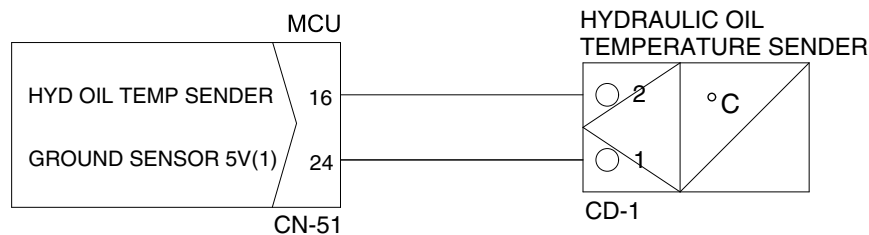

160A6ES08

8. WHEN COOLANT TEMPERATURE GAUGE DOES NOT OPERATE

- Before disconnecting the connector, always turn the starting switch OFF.
- Before carrying out below procedure, check all the related connectors are properly inserted.
- After checking, insert the disconnected connectors again immediately unless otherwise specified.

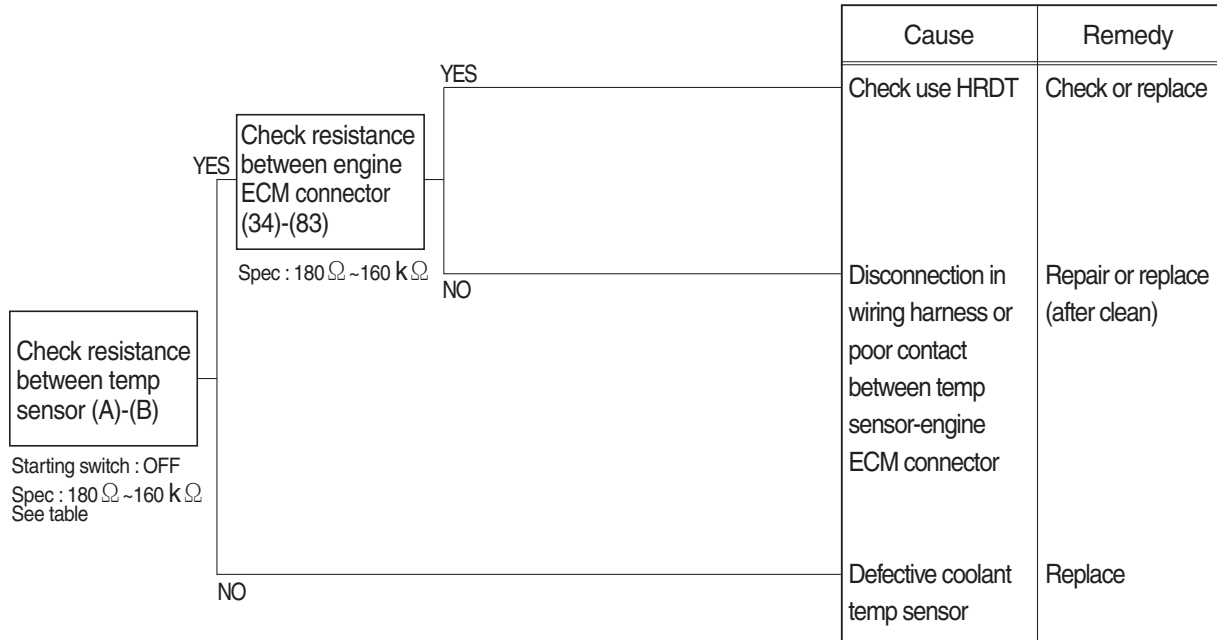

Check Table

| Temperature (°C) | 0 | 25 | 50 | 80 | 95 |
|------------------|-------|----------|---------|---------|---------|
| Resistance (kΩ) | 30~37 | 9.3~10.7 | 3.2~3.8 | 1.0~1.3 | 0.7~0.8 |

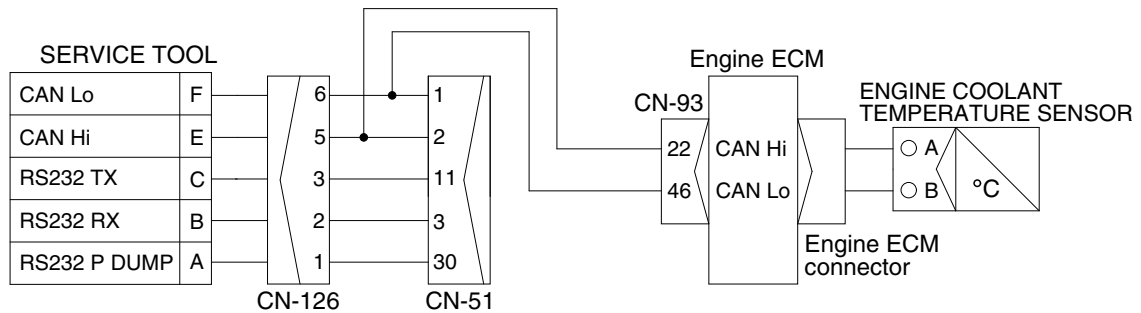

9. WHEN FUEL GAUGE DOES NOT OPERATE (HCESPN 301, FMI 3 or 4)

- Before disconnecting the connector, always turn the starting switch OFF.
- Before carrying out below procedure, check all the related connectors are properly inserted.
- After checking, insert the disconnected connectors again immediately unless otherwise specified.

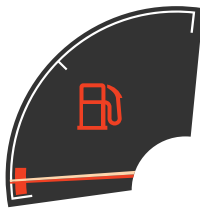
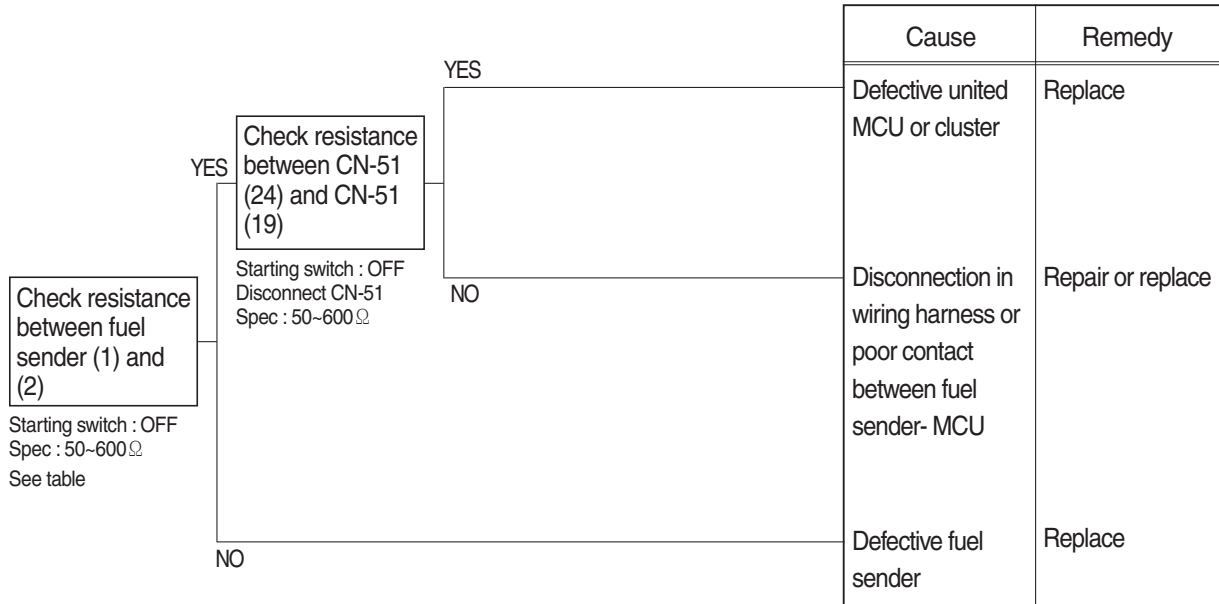

Check Table

| Range | Resistance (Ω) | Range | Resistance (Ω) |
|-------|----------------|---------------|----------------|
| Full | 50 | 5/12 | 400 |
| 11/12 | 100 | 4/12 | 450 |
| 10/12 | 150 | 3/12 | 500 |
| 9/12 | 200 | 2/12 | 550 |
| 8/12 | 250 | 1/12 | 600 |
| 7/12 | 300 | Empty warning | 700 |
| 6/12 | 350 | - | - |

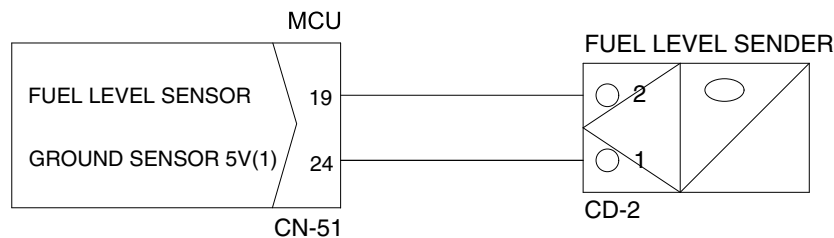

10. WHEN SAFETY SOLENOID DOES NOT OPERATE

- Before disconnecting the connector, always turn the starting switch OFF.
- Before carrying out below procedure, check all the related connectors are properly inserted and short of fuse No. 26.
- After checking, insert the disconnected connectors again immediately unless otherwise specified.

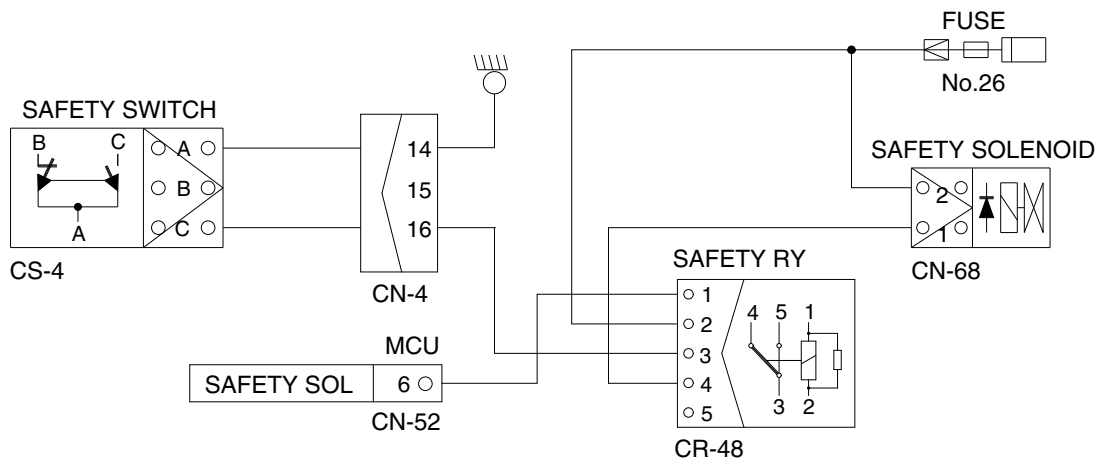
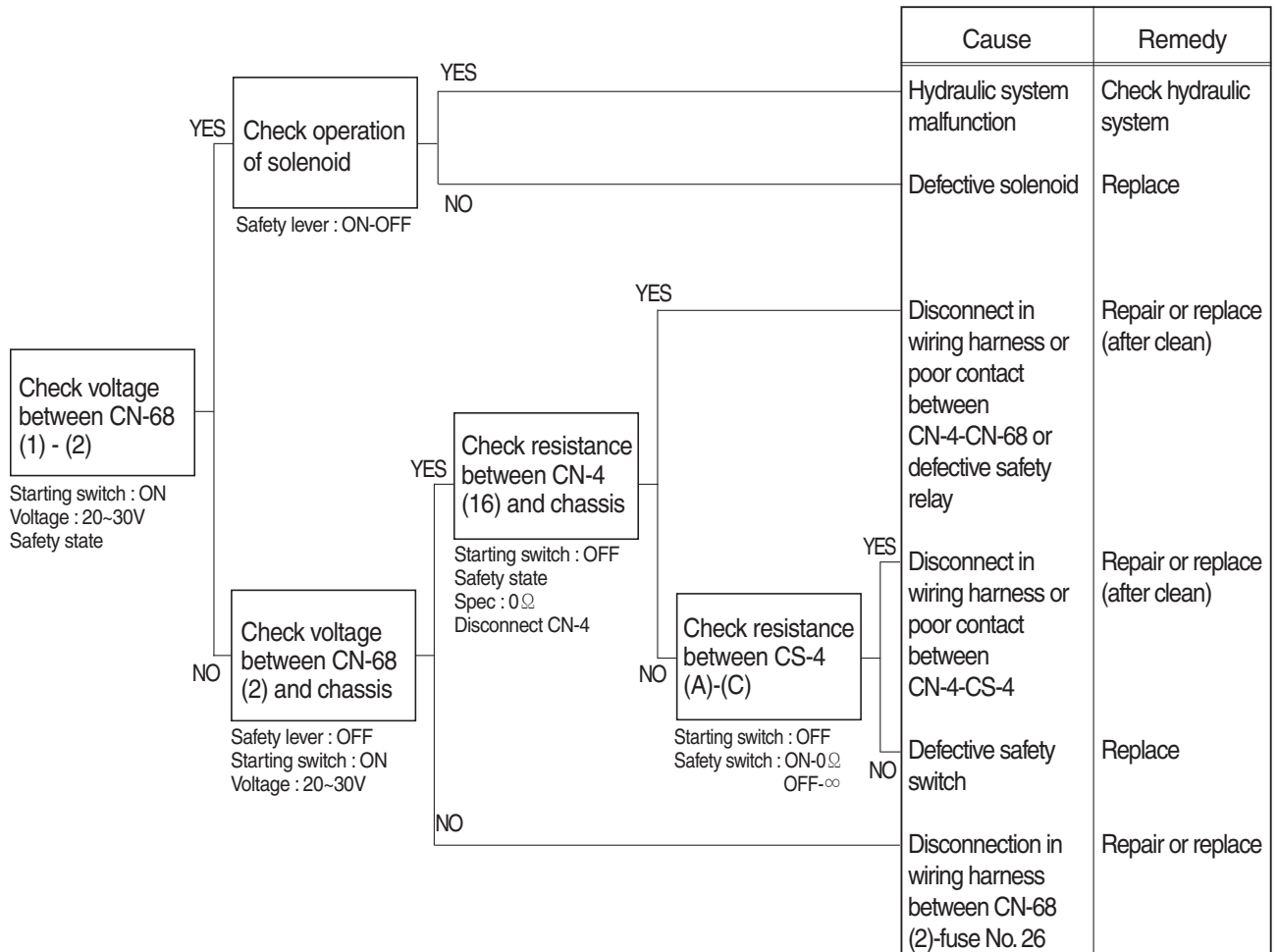

11. WHEN TRAVEL SPEED 1, 2 DOES NOT OPERATE (HCESPN 167, FMI 4 or 6)

- Before disconnecting the connector, always turn the starting switch OFF.
- Before carrying out below procedure, check all the related connectors are properly inserted and short of fuse No. 28.
- After checking, insert the disconnected connectors again immediately unless otherwise specified.

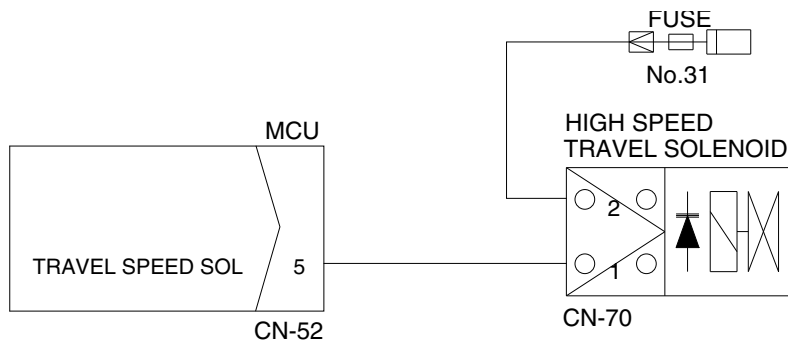
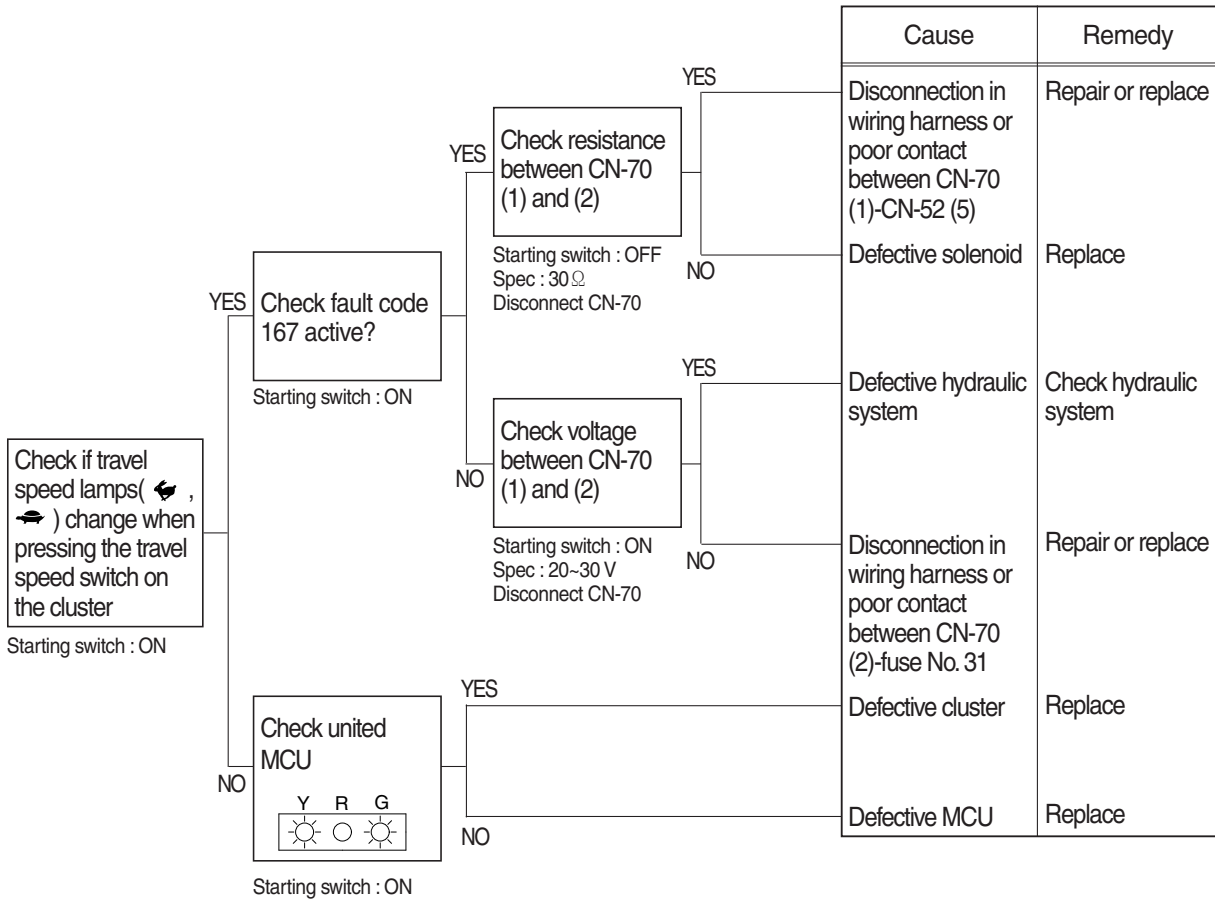

160A6ES11

12. TRAVEL ALARM DOES NOT SOUND OR DOES NOT STOP SOUNDING

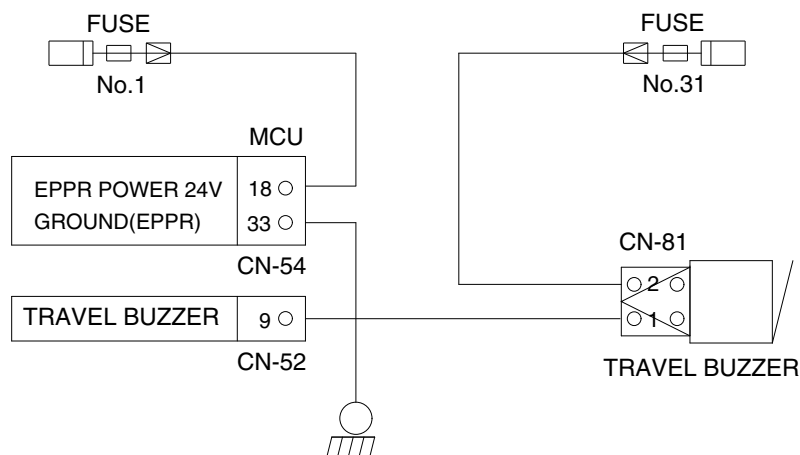
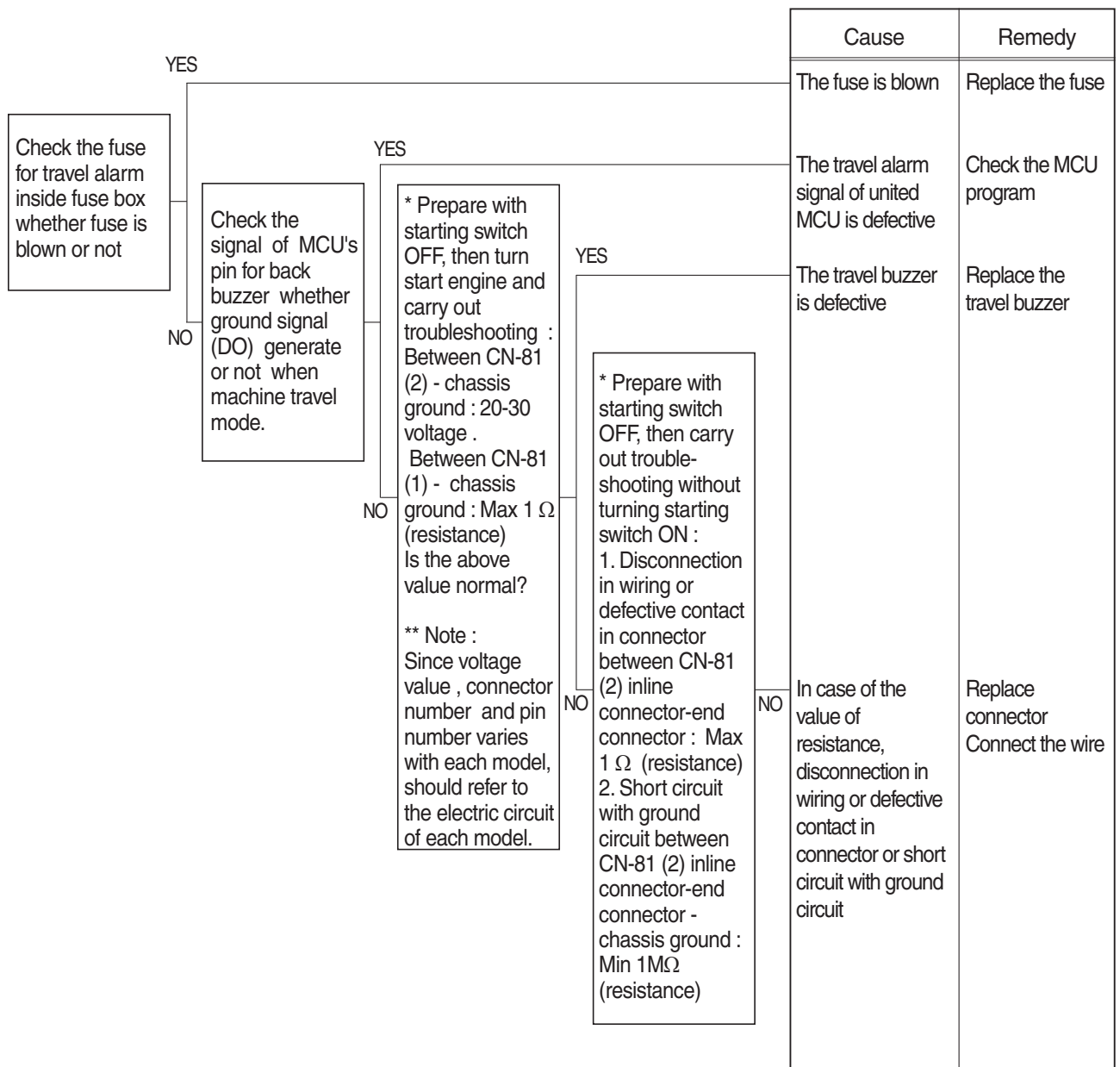

13. HORN DOES NOT SOUND

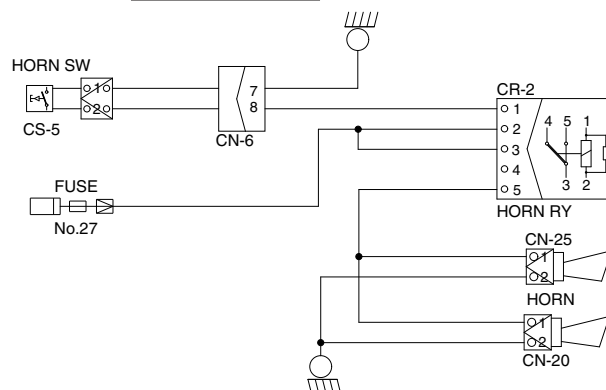
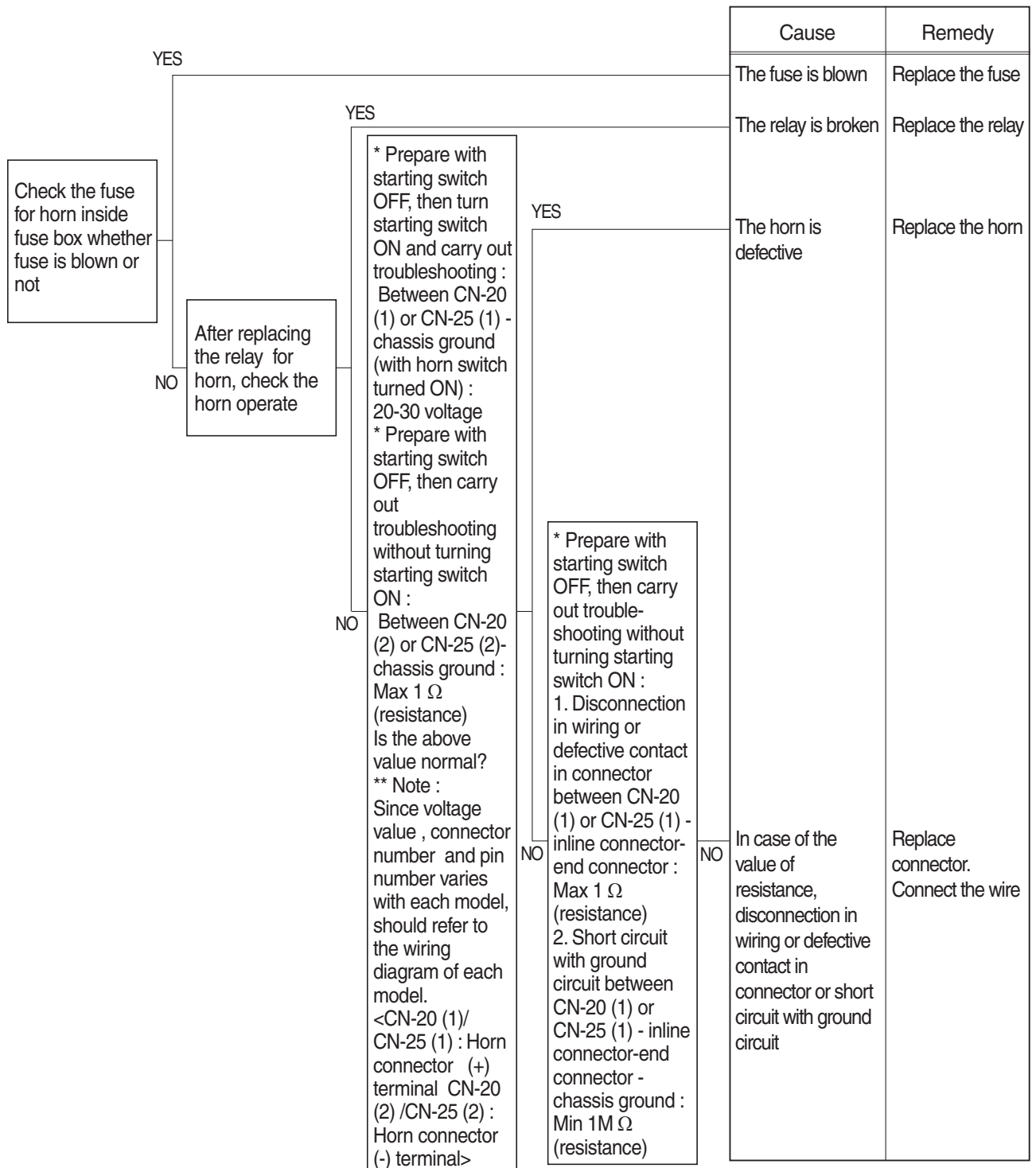

14. WHEN ENGINE DOES NOT START (lights up condition)

- Before disconnecting the connector, always turn the starting switch OFF.
- Before carrying out below procedure, check all the related connectors are properly inserted and short of fuse No. 5, 8, 12, 13, 23.
- After checking, insert the disconnected connectors again immediately unless otherwise specified.

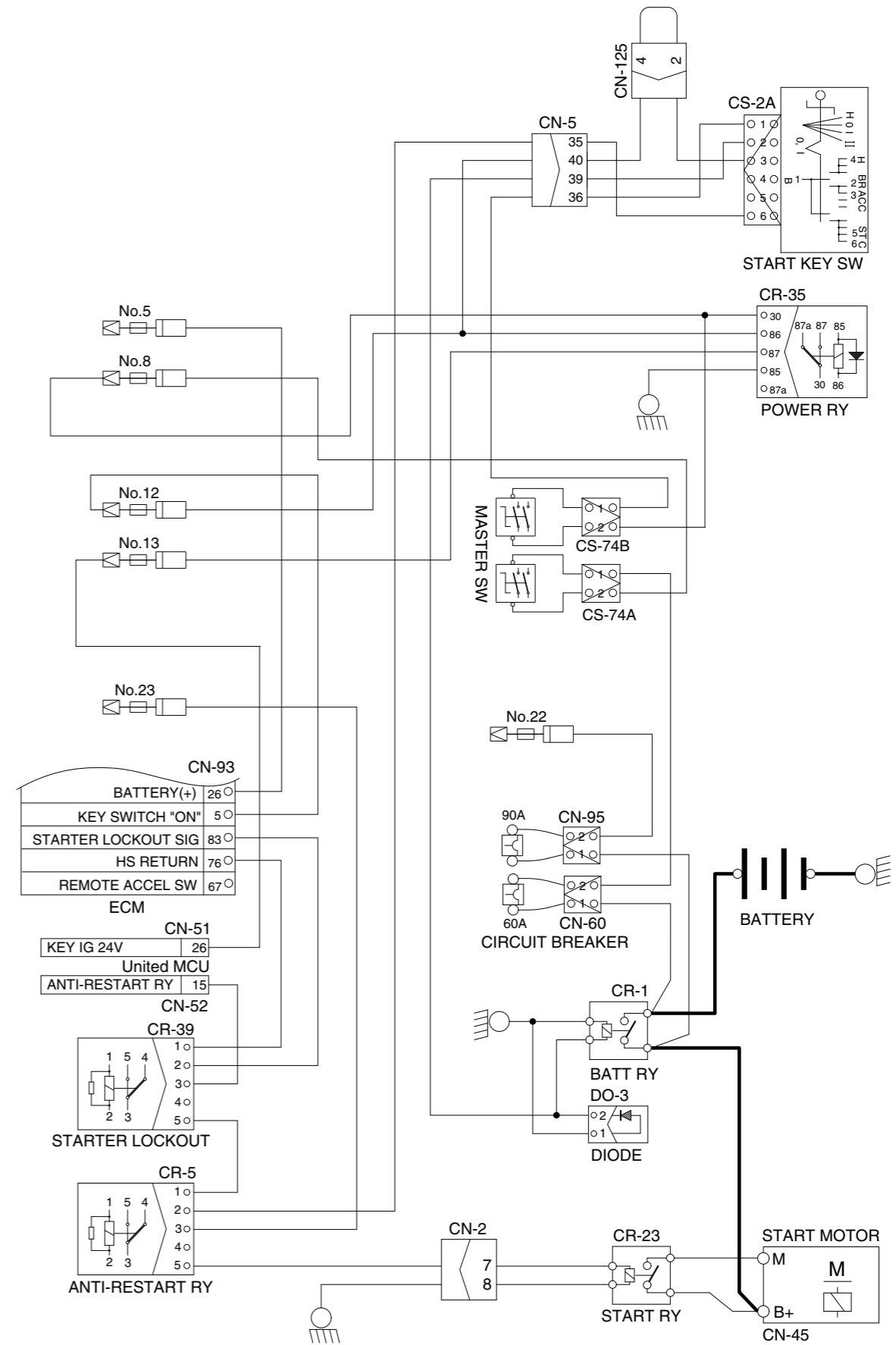
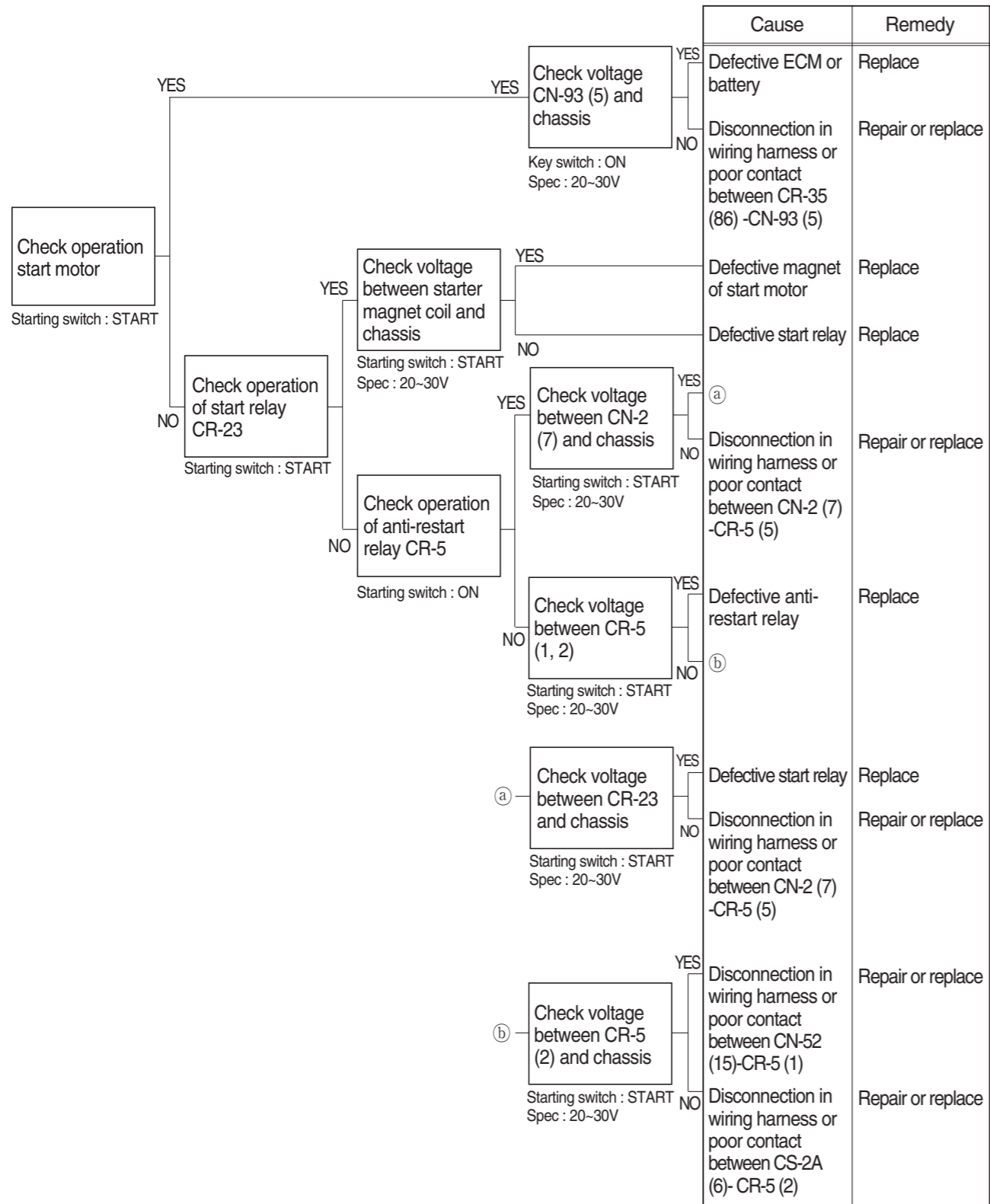

15. WHEN STARTING SWITCH ON DOES NOT OPERATE

- Before disconnecting the connector, always turn the starting switch OFF.
- Before carrying out below procedure, check all the related connectors are properly inserted, master switch ON and check open circuit of circuit breaker (CN-60).
- After checking, insert the disconnected connectors again immediately unless otherwise specified.

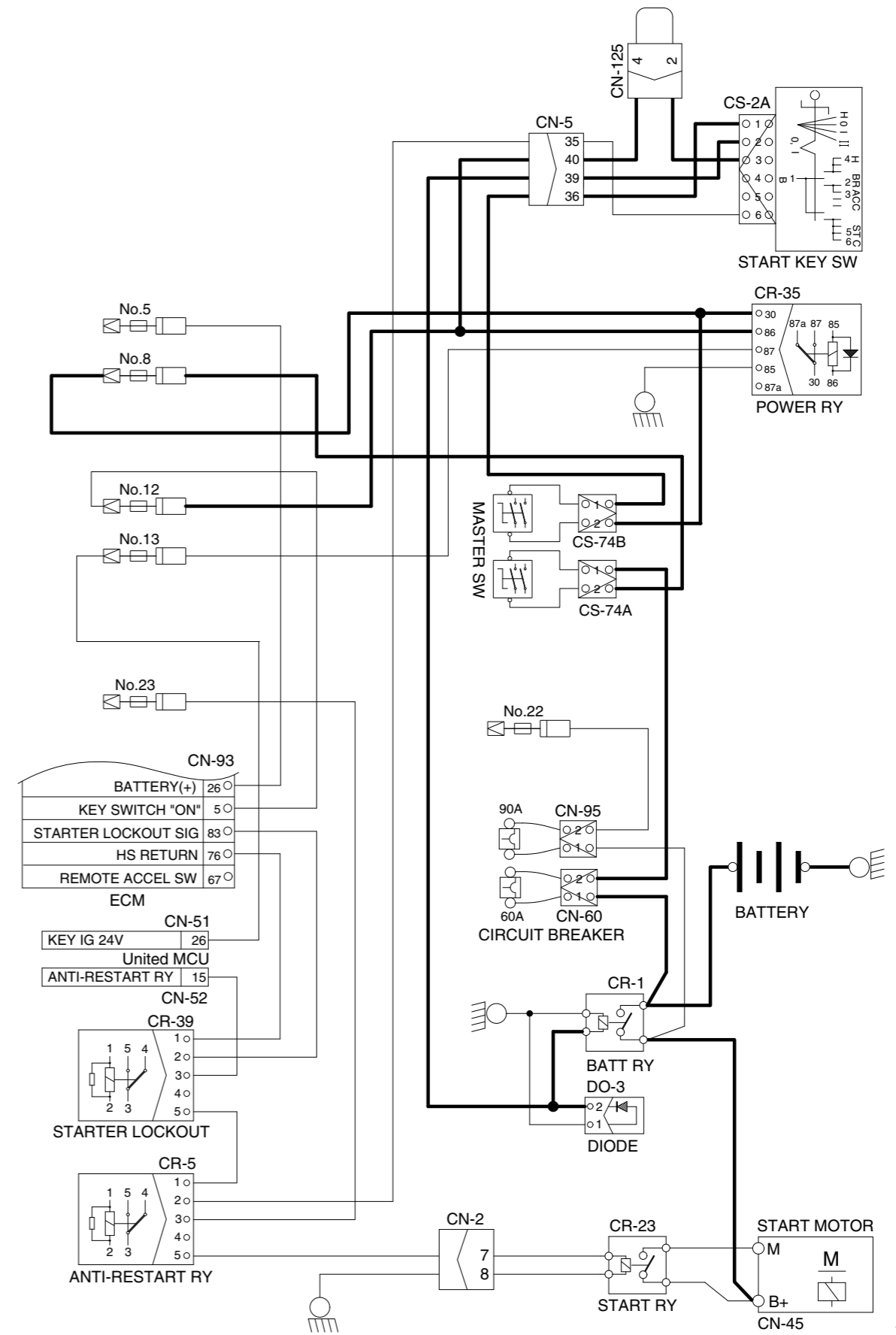
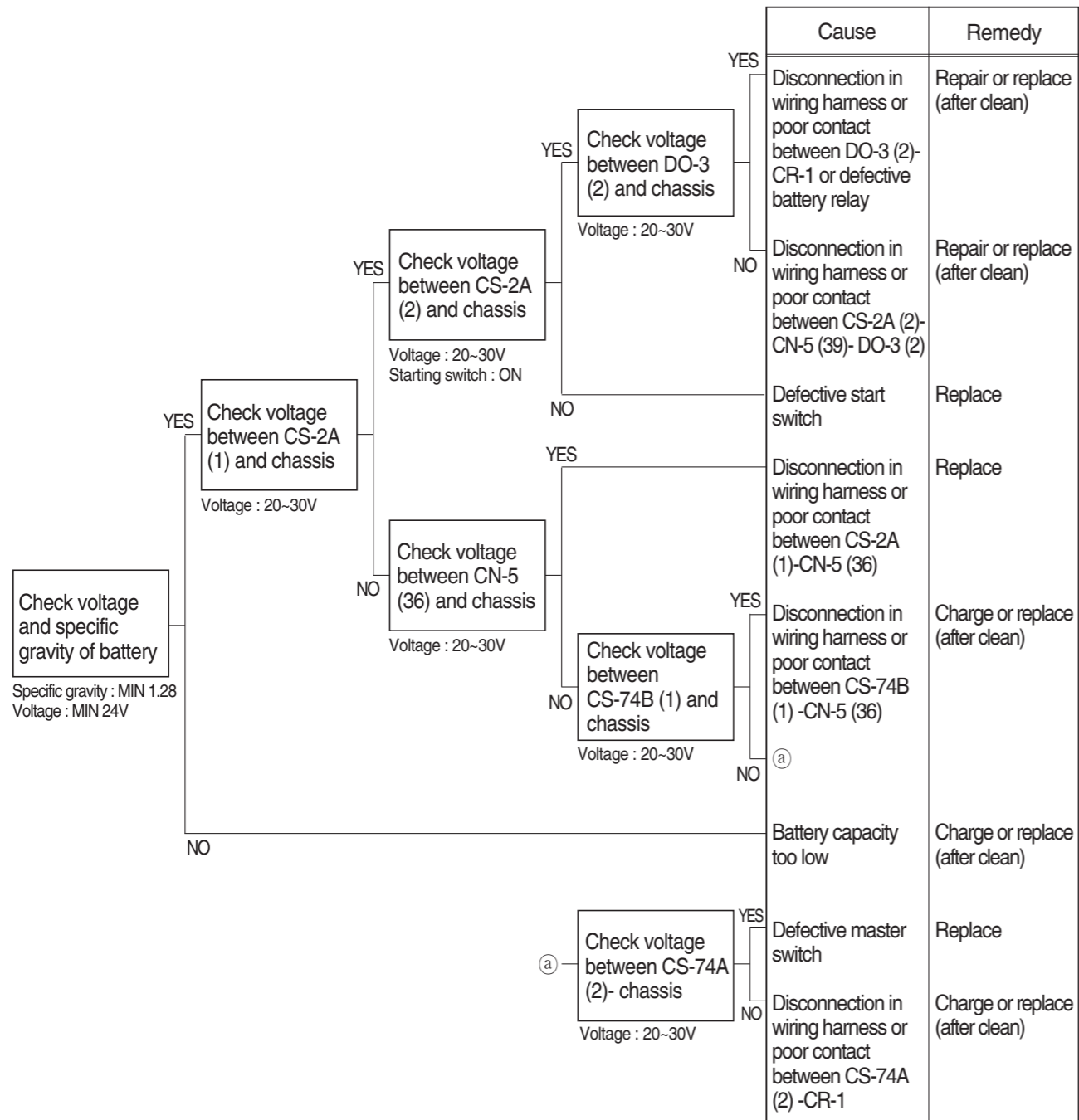

16. WHEN STARTING SWITCH IS TURNED ON, WIPER MOTOR DOES NOT OPERATE

- Before disconnecting the connector, always turn the starting switch OFF.
- Before carrying out below procedure, check all the related connectors are properly inserted and the fuse No. 10, 14 and 20 is not blown out.
- After checking, insert the disconnected connectors again immediately unless otherwise specified.

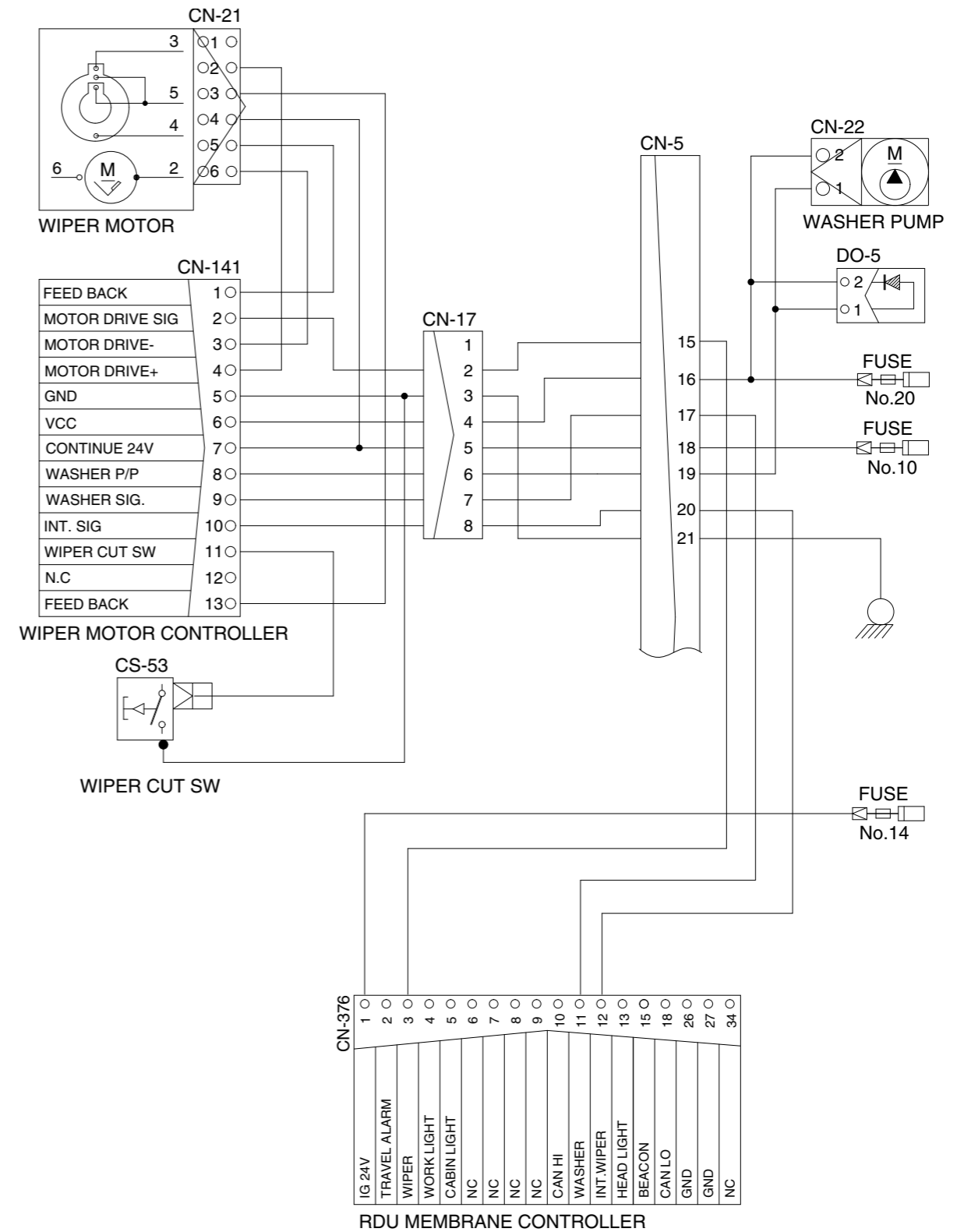
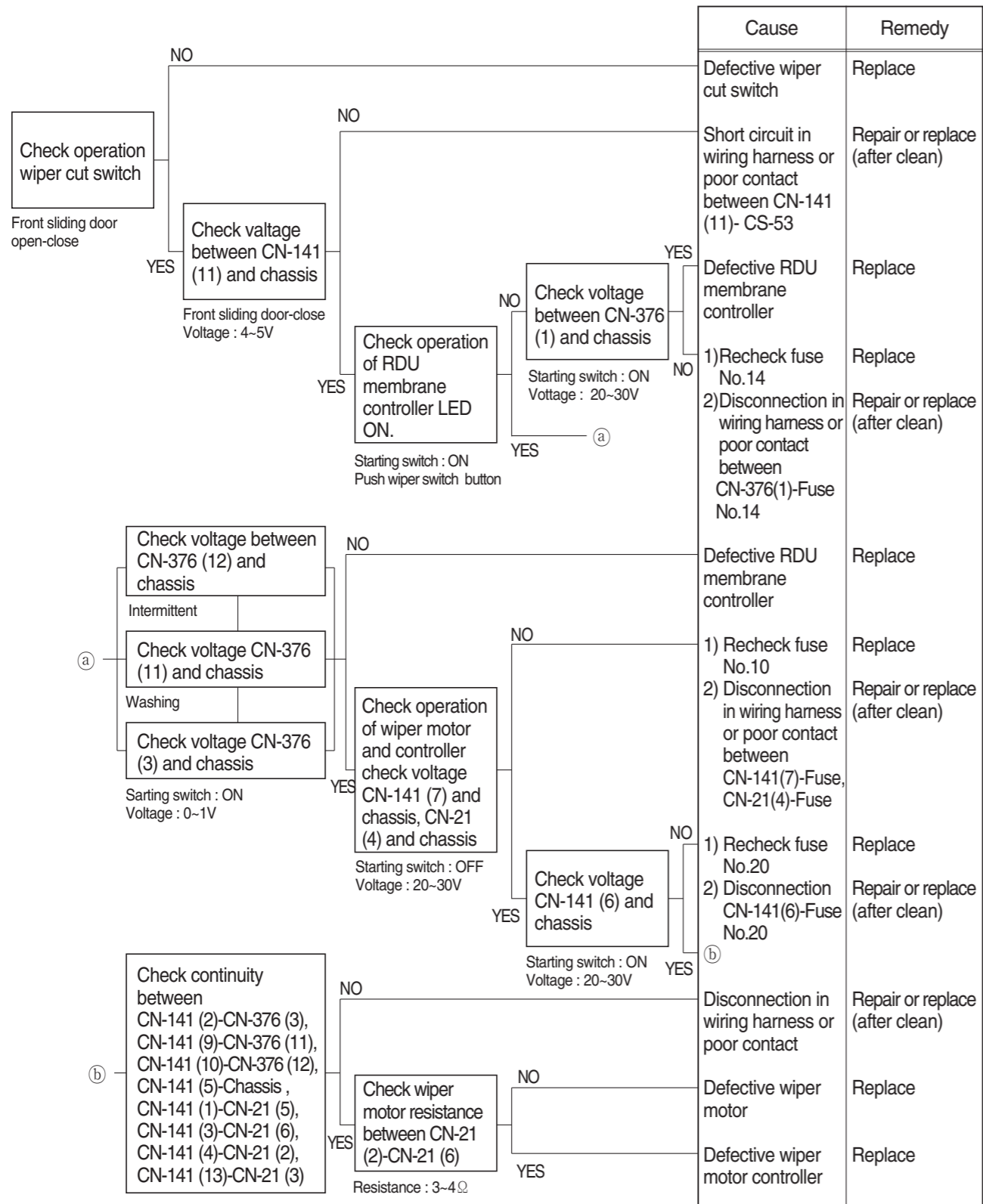

17. WHEN STARTING SWITCH IS TURNED ON, HEAD LAMP DOES NOT LIGHTS UP

- Before disconnecting the connector, always turn the starting switch OFF.
- Before carrying out below procedure, check all the related connectors are properly inserted and short of fuse No.14 & 21.
- After checking, insert the disconnected connectors again immediately unless otherwise specified.

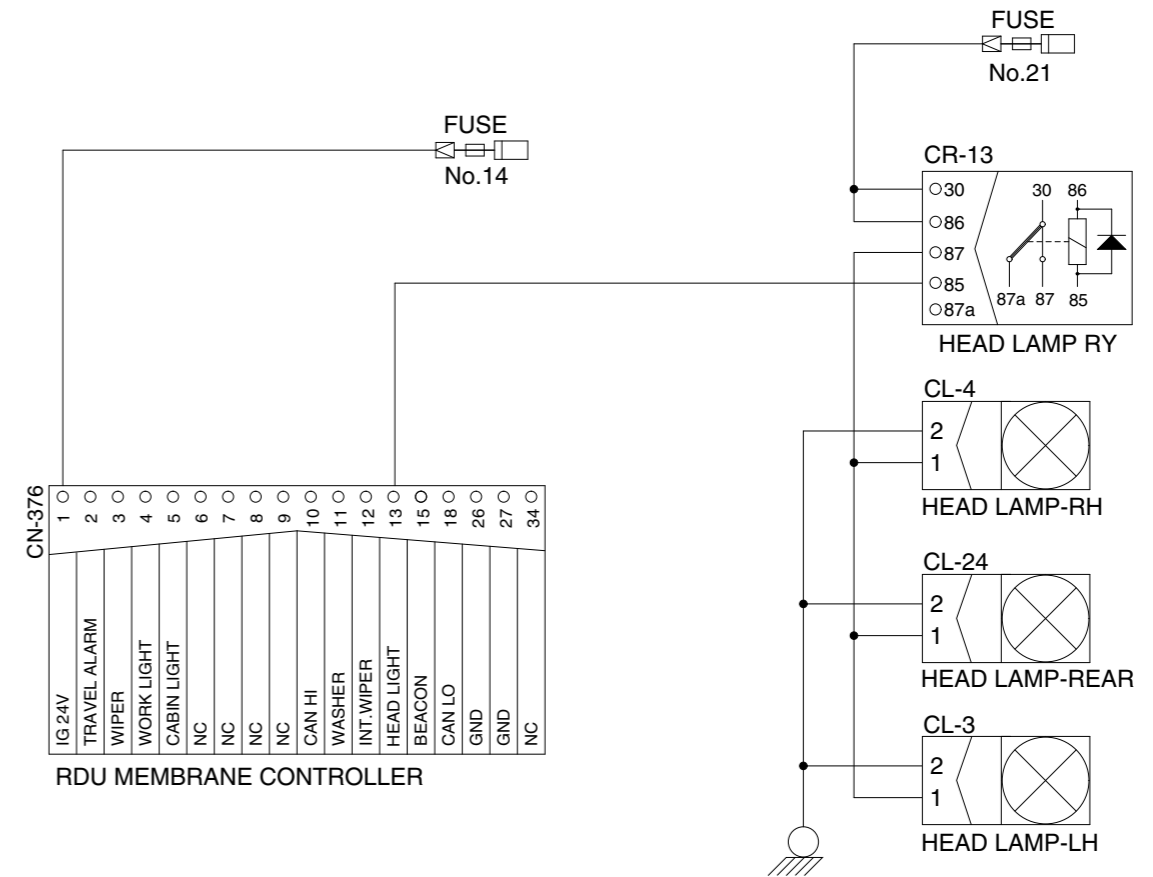
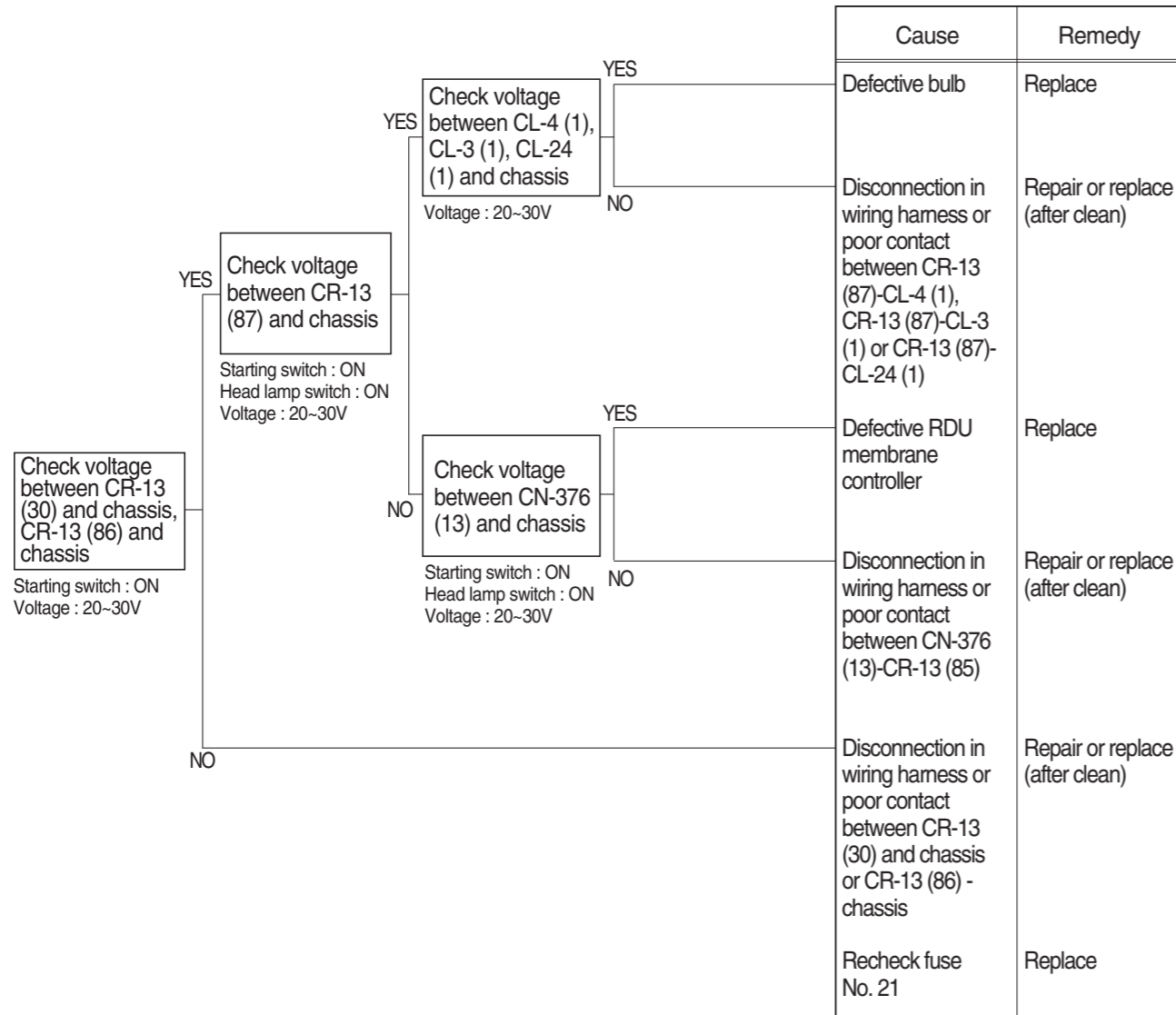

18. WHEN STARTING SWITCH IS TURNED ON, WORK LAMP DOES NOT LIGHTS UP

- Before disconnecting the connector, always turn the starting switch OFF.
- Before carrying out below procedure, check all the related connectors are properly inserted and short of fuse No.14 & 18.
- After checking, insert the disconnected connectors again immediately unless otherwise specified.

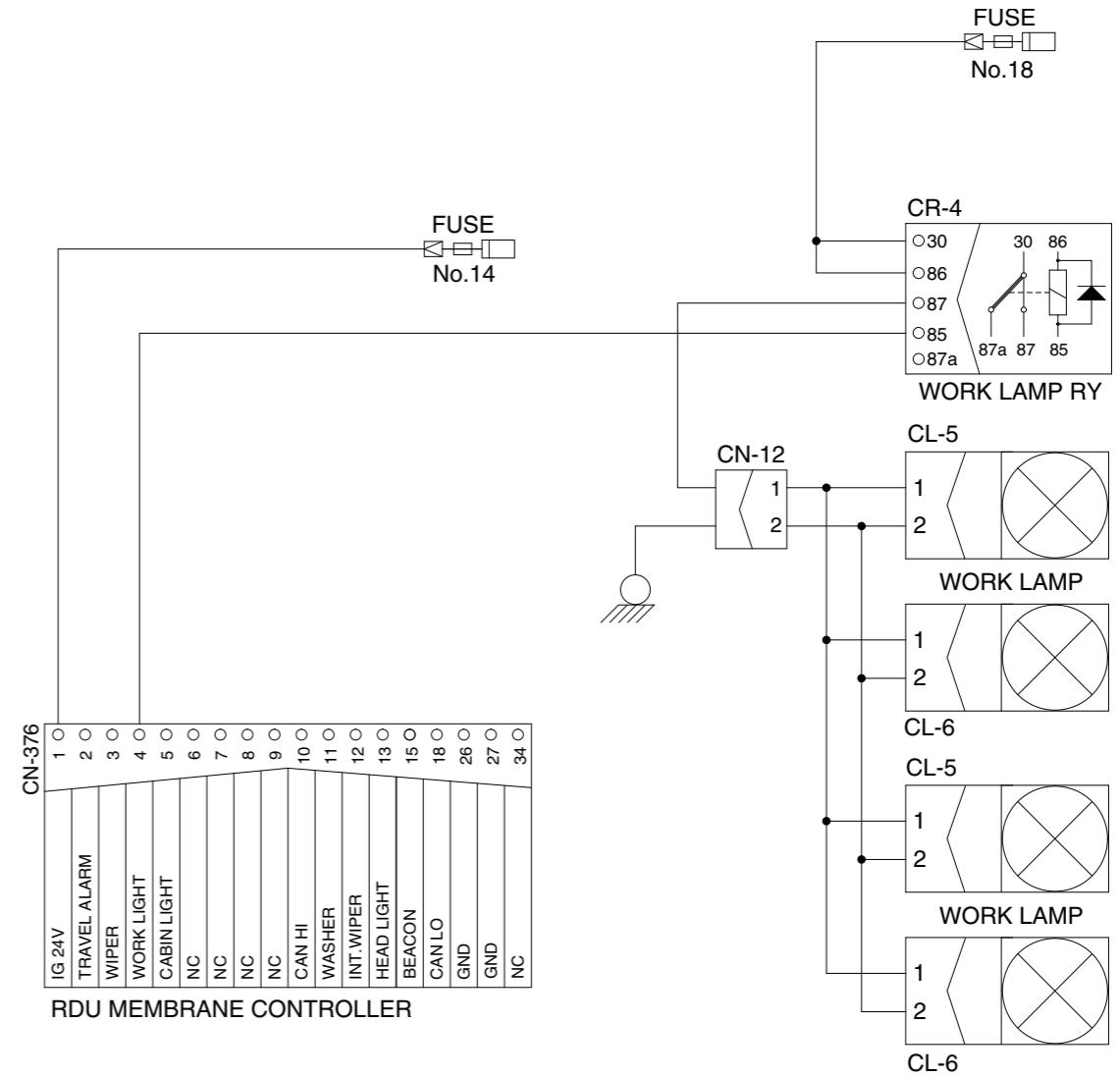
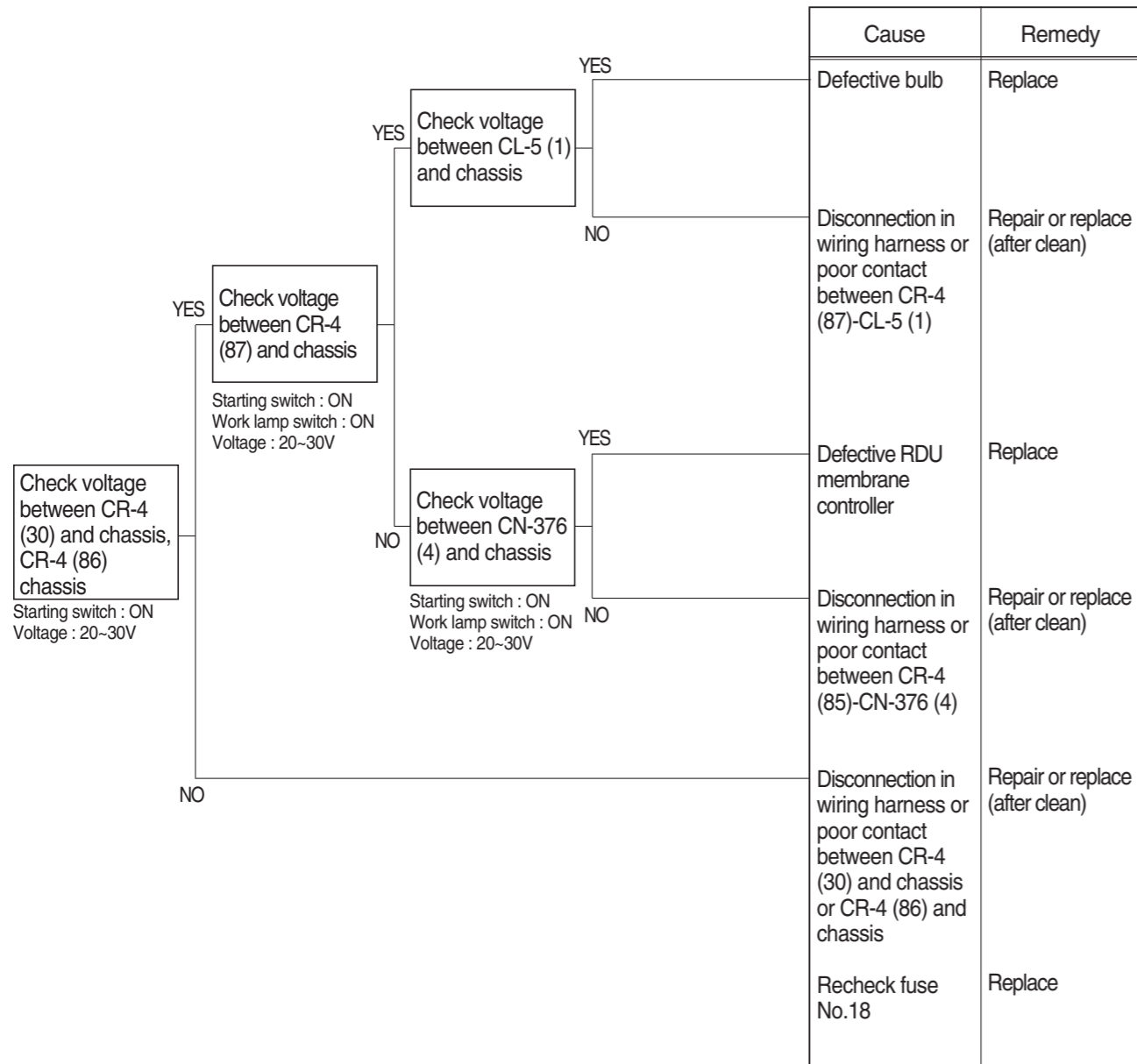

GROUP 4 MECHATRONICS SYSTEM

1. ALL ACTUATORS SPEED ARE SLOW

- ※ Boom, Arm, Bucket, Swing and travel speed are slow, but engine speed is good.
- ※ Spec : P-mode 1950 ± 50 rpm S-mode 1850 ± 50 rpm E-mode 1750 ± 50 rpm
- ※ Before carrying out below procedure, check all the related connectors are properly inserted and fault code on the cluster.

1) INSPECTION PROCEDURE

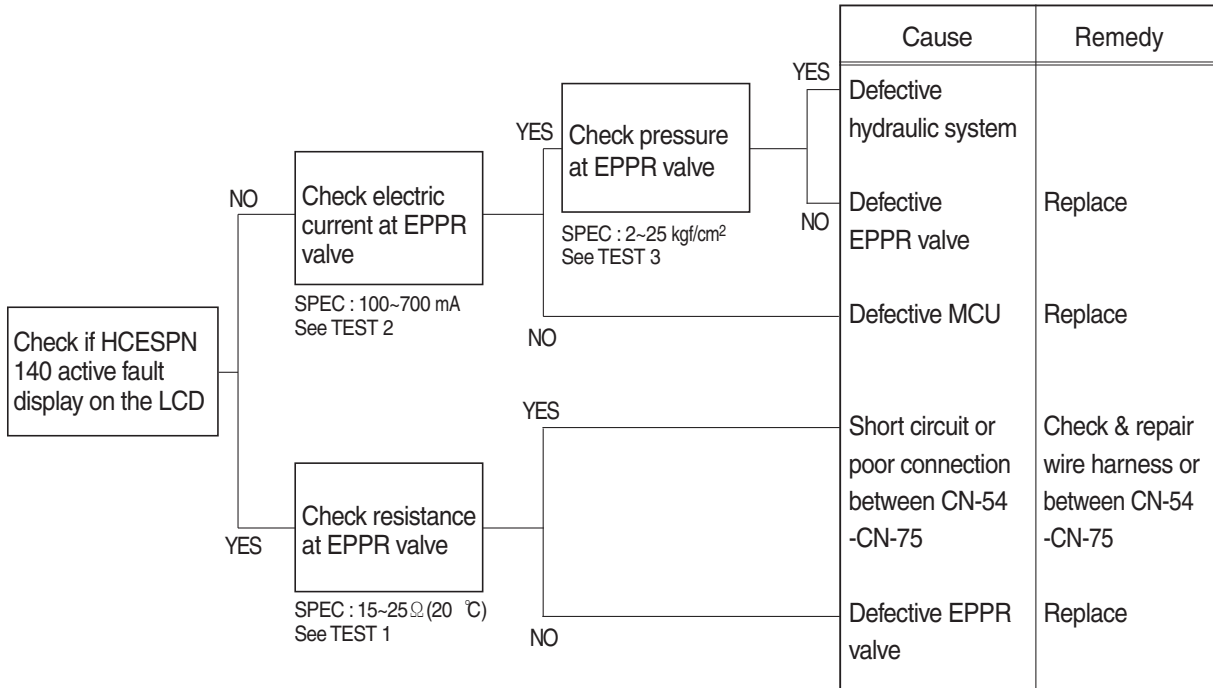

Wiring diagram

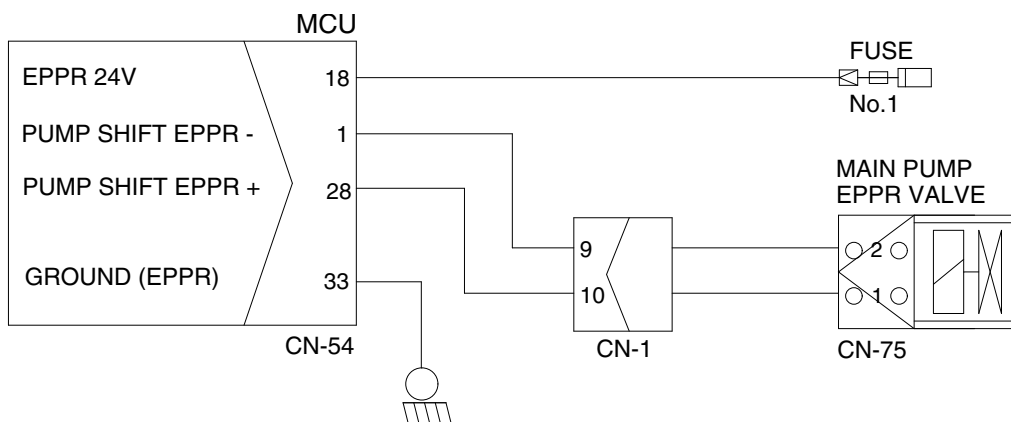

160A6MS01

2) TEST PROCEDURE

(1) **Test 1** : Check resistance at connector CN-75.

- ① Starting switch OFF.
- ② Disconnect connector CN-75 from EPPR valve at main hydraulic pump.
- ③ Check resistance between 2 lines as figure.

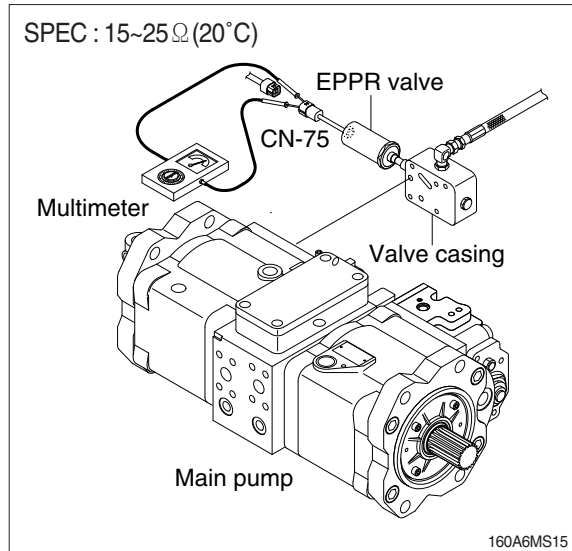

(2) **Test 2** : Check electric current at EPPR valve.

- ① Disconnect connector CN-75 from EPPR valve.
- ② Insert the adapter to CN-75 and install multimeter as figure.
- ③ Start engine.
- ④ Set S-mode and cancel auto decel mode.
- ⑤ Position the multimodal dial at 10.
- ⑥ If tachometer show approx 1850 ± 50 rpm disconnect one wire harness from EPPR valve.
- ⑦ Check electric current at bucket circuit relief position.

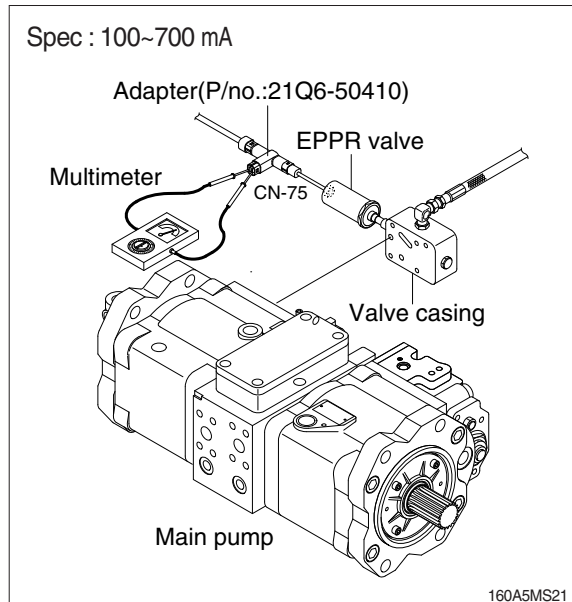

(3) **Test 3** : Check pressure at EPPR valve.

- ① Start engine.
- ② Set S-mode and cancel auto decel mode.
- ③ Position the multimodal dial at 10.
- ④ Slowly operate control lever of bucket functions at full stroke over relief and measure the EPPR valve pressure by the the monitoring menu of the cluster.
- ⑤ If pressure is not correct, adjust it.
- ⑥ After adjust, test the machine.

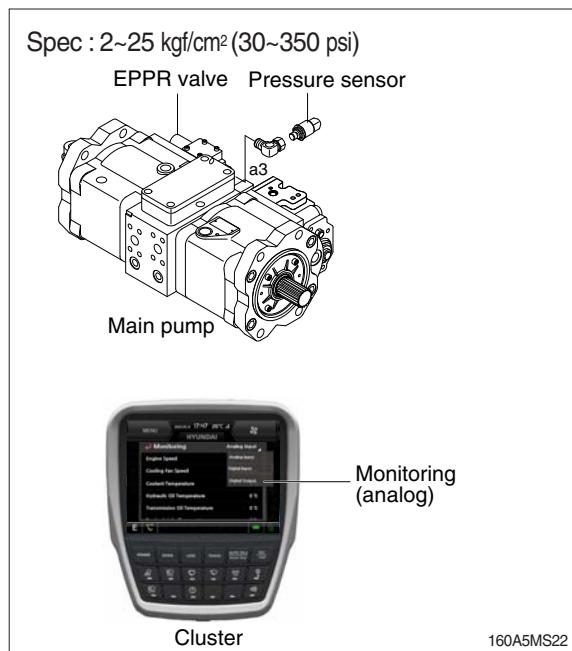

2. ENGINE STALL

※ Before carrying out below procedure, check all the related connectors are properly inserted.

1) INSPECTION PROCEDURE

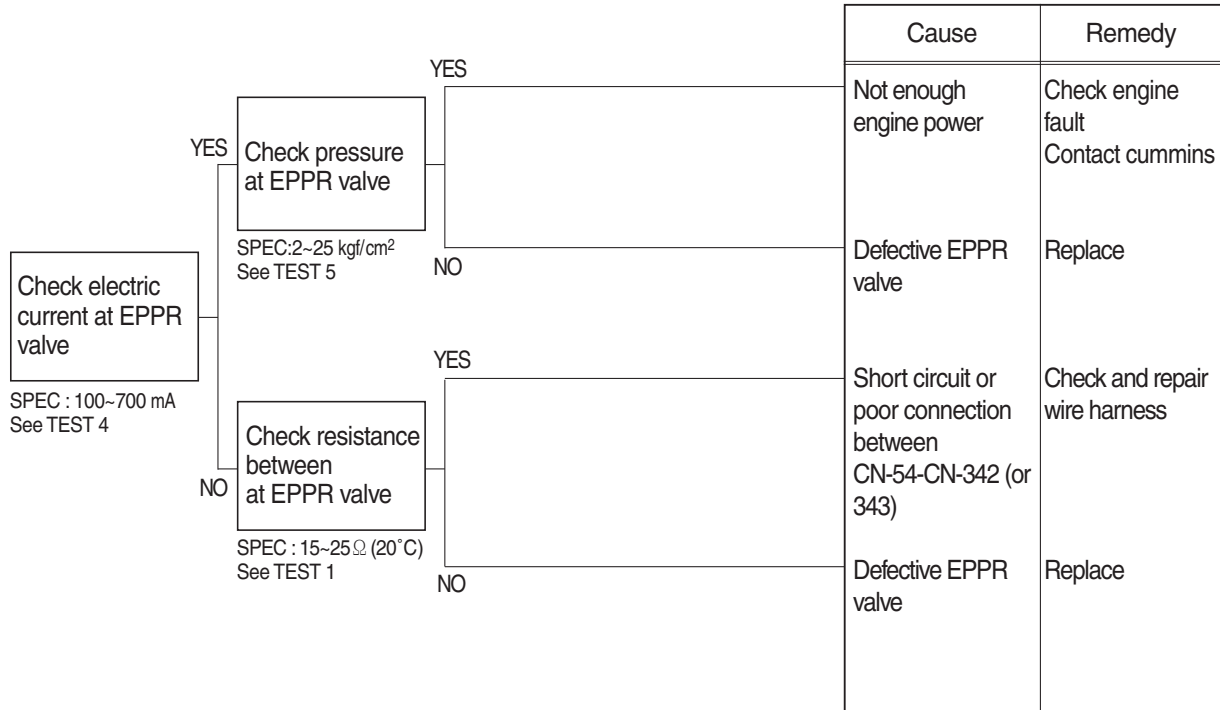

Wiring diagram

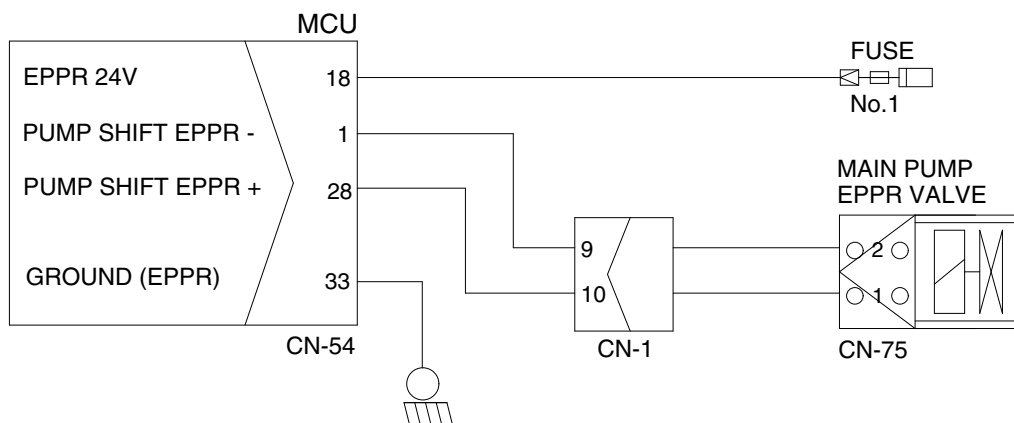

160A6MS01

2) TEST PROCEDURE

(1) **Test 4** : Check electric current at EPPR valve.

- ① Disconnect connector CN-75 from EPPR valve.
- ② Insert the adapter to CN-75 and install multimeter as figure.
- ③ Start engine.
- ④ Set S-mode and cancel auto decel mode.
- ⑤ Position the multimodal dial at 10.
- ⑥ If rpm show approx 1850 ± 50 rpm disconnect one wire harness from EPPR valve. Check electric current at bucket circuit
- ⑦ relief position.

Spec : 100~700 mA

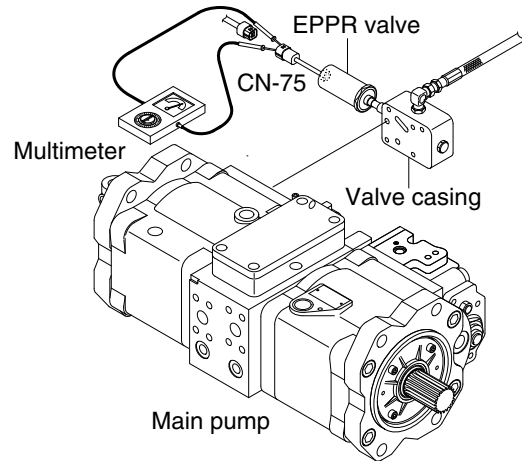

160A6MS15

(2) **Test 5** : Check pressure at EPPR valve.

- ① Start engine.
- ② Set S-mode and cancel auto decel mode.
- ③ Position the multimodal dial at 10.
- ④ Slowly operate control lever of bucket functions at full stroke over relief and measure the EPPR valve pressure by the the monitoring menu of the cluster.
- ⑤ If pressure is not correct, adjust it.
- ⑥ After adjust, test the machine.

SPEC : 2~25 kgf/cm² (30~350 psi)

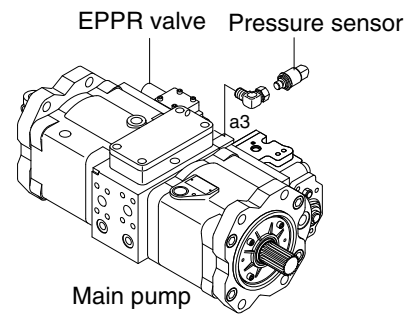

160A5MS22

3. MALFUNCTION OF CLUSTER OR MODE SELECTION SYSTEM

※ Before carrying out below procedure, check all the related connectors are properly inserted.

1) INSPECTION PROCEDURE

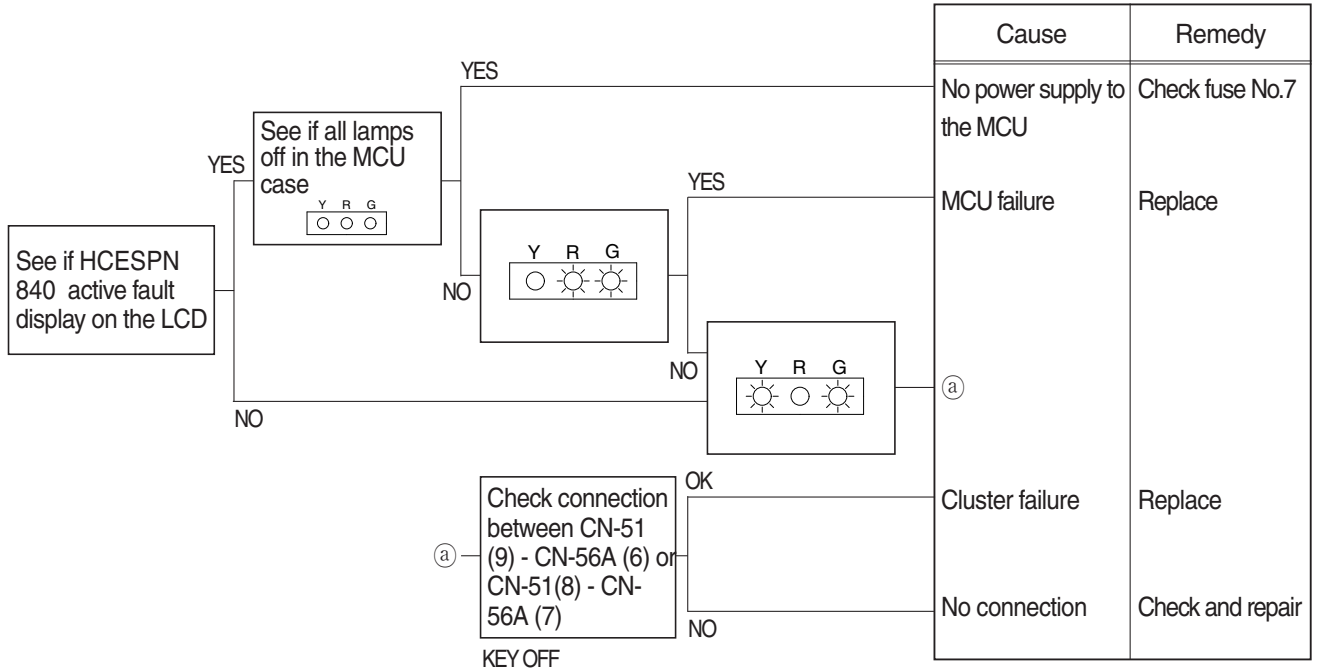

Wiring diagram

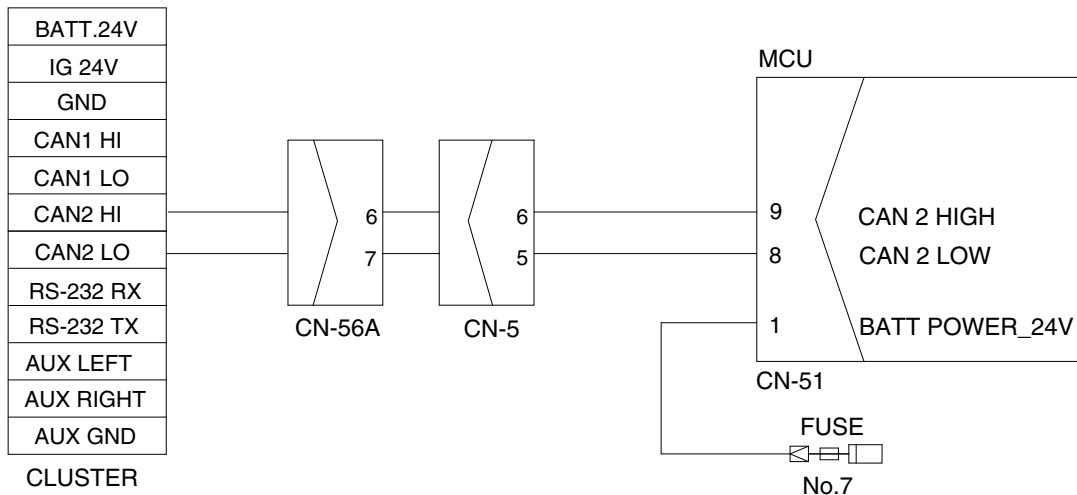

160A6MS02

4. AUTO DECEL SYSTEM DOES NOT WORK

- Fault code : HCESPN 105, FMI 0~4 (work pressure sensor)
HCESPN 108, FMI 0~4 (travel oil pressure sensor)

※ Before carrying out below procedure, check all the related connectors are properly inserted.

1) INSPECTION PROCEDURE

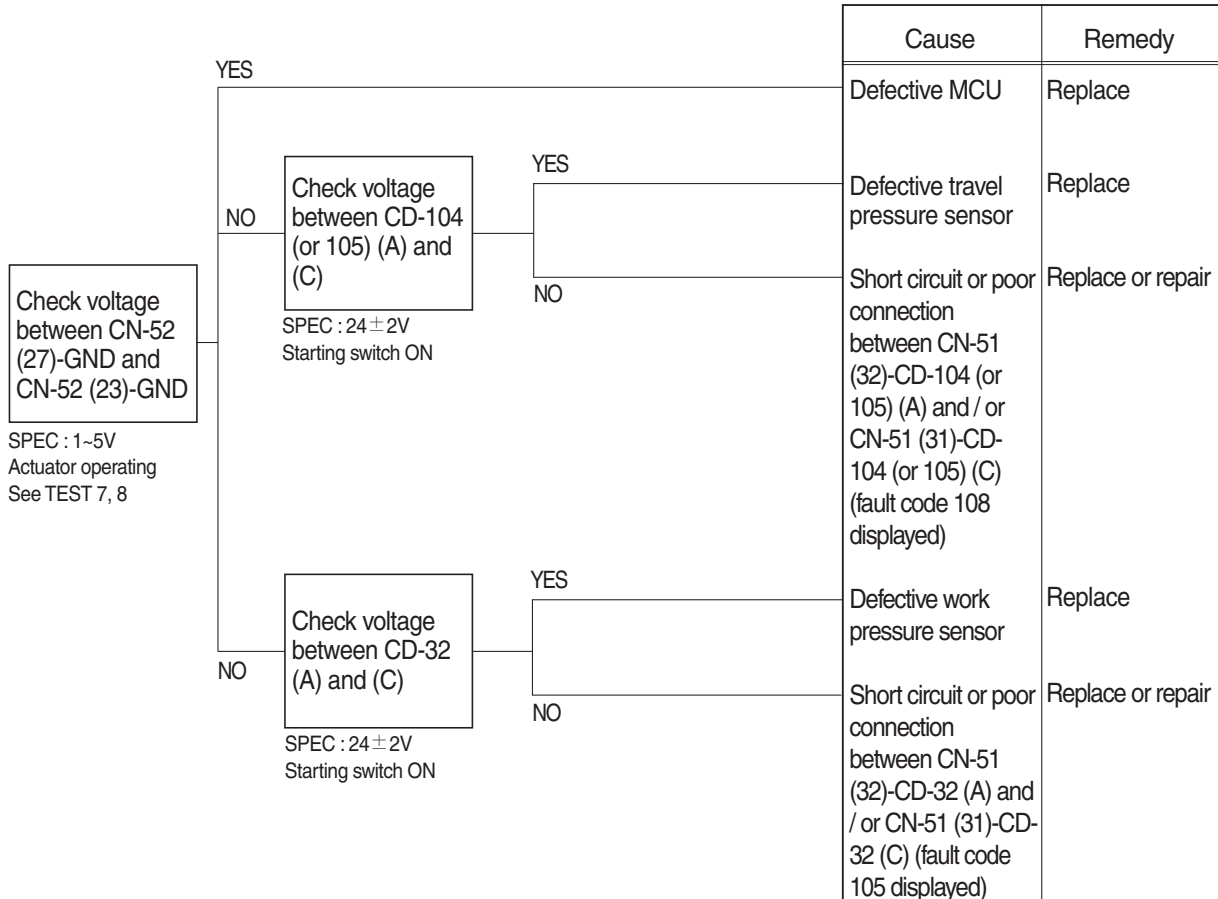

Wiring diagram

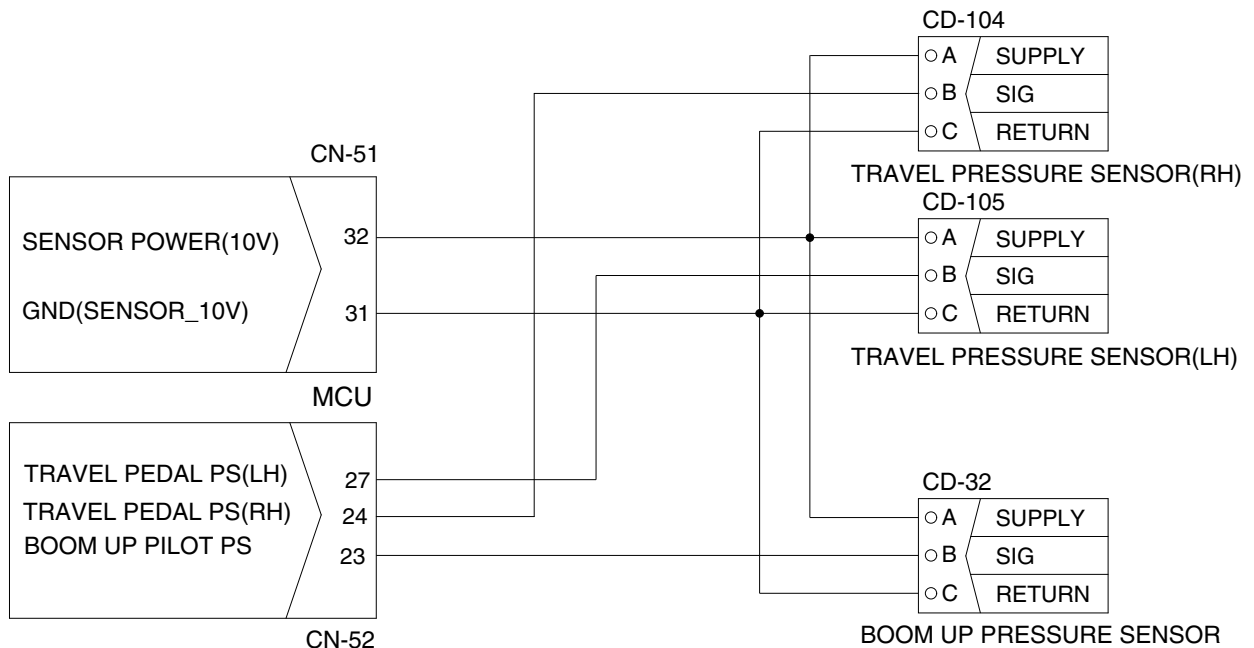

2) TEST PROCEDURE

(1) **Test 7** : Check voltage at CN-52 (24 or 27) and ground.

- ① Prepare 1 piece of thin sharp pin, steel or copper.
- ② Insert prepared pin to rear side of connectors : One pin to (24 or 27) of CN-52.
- ③ Starting switch ON.
- ④ Check voltage as figure.

(2) **Test 8** : Check voltage at CN-52 (19) and ground.

- ① Prepare 1 piece of thin sharp pin, steel or copper
- ② Insert prepared pin to rear side of connectors : One pin to (23) of CN-52.
- ③ Starting key ON.
- ④ Check voltage as figure.

SPEC : Actuator operating : 1~5 V

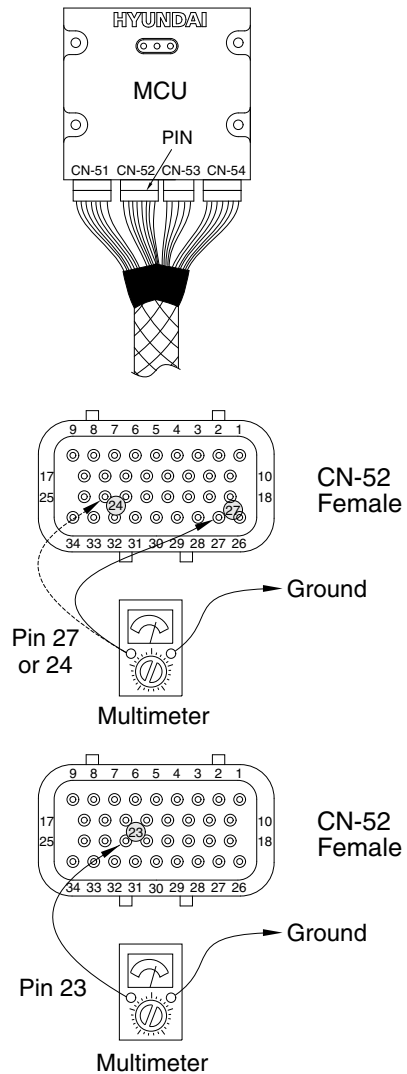

235A6MS104

5. MALFUNCTION OF PUMP 1 PRESSURE SENSOR

· Fault code : HCESPN 120, FMI 0~4

※ Before carrying out below procedure, check all the related connectors are properly inserted.

1) INSPECTION PROCEDURE

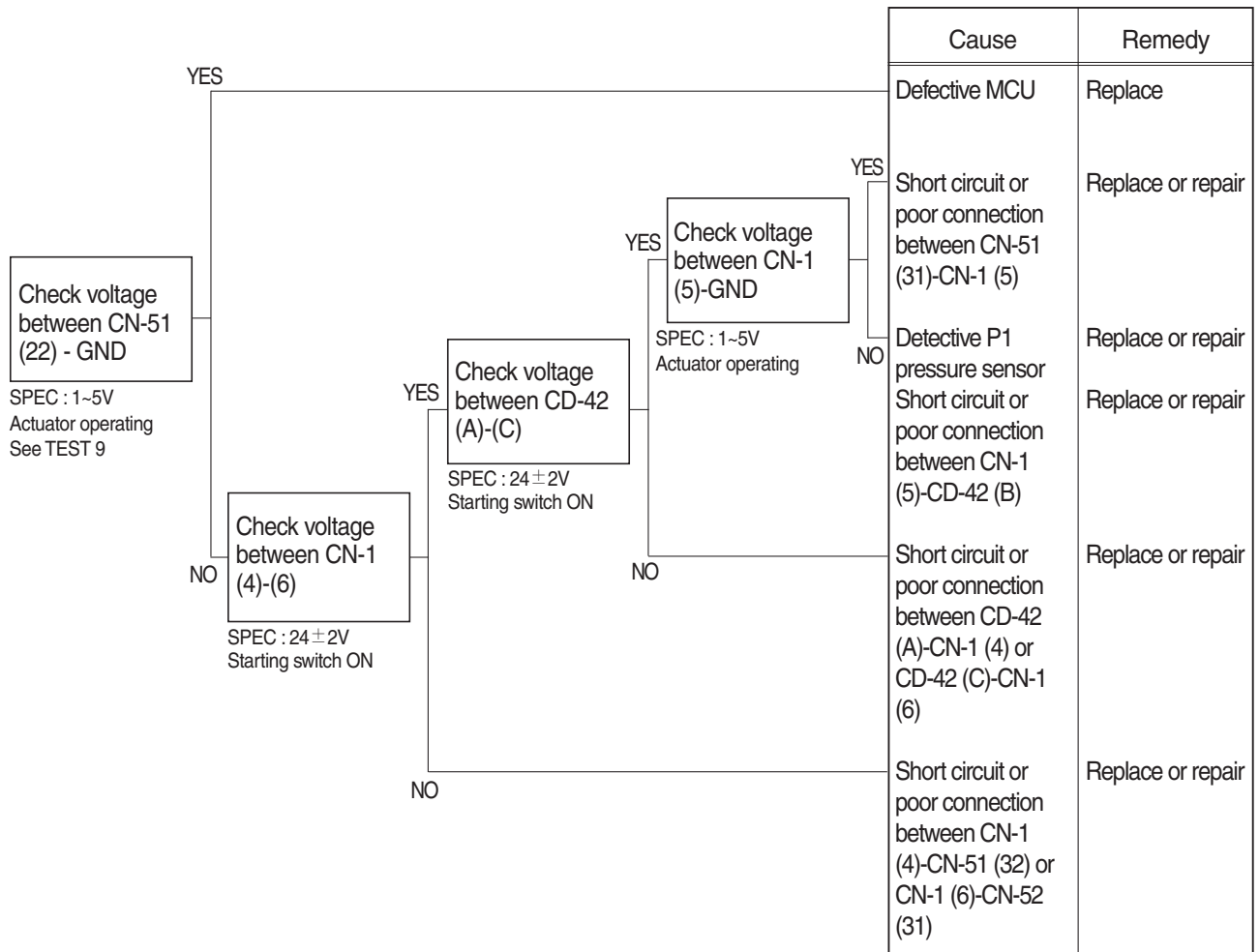

Wiring diagram

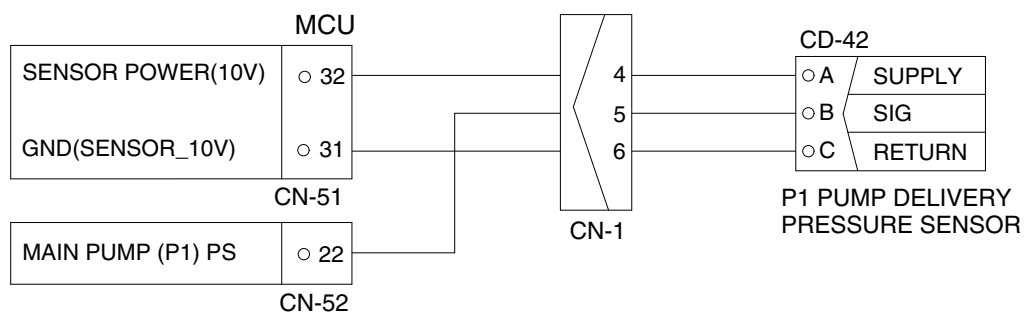

2) TEST PROCEDURE

(1) **Test 9** : Check voltage at CN-52 (22) and ground.

- ① Prepare 1 piece of thin sharp pin, steel or copper.
- ② Insert prepared pin to rear side of connectors : One pin to (22) of CN-52.
- ③ Starting switch ON.
- ④ Check voltage as figure.

SPEC : Actuator operating : 1~5 V

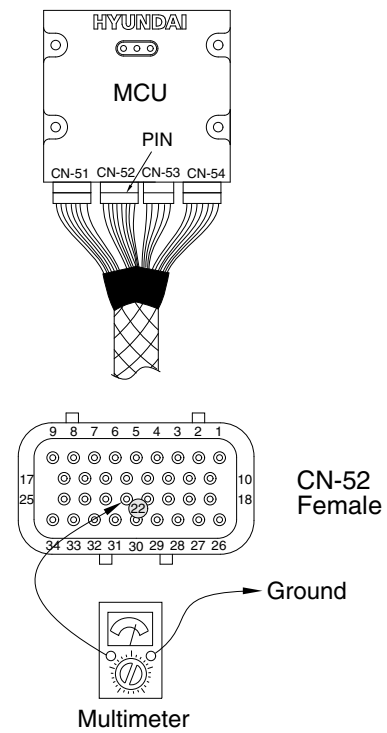

220A6MS106

6. MALFUNCTION OF PUMP 2 PRESSURE SENSOR

· Fault code : HCESPN 121, FMI 0~4

※ Before carrying out below procedure, check all the related connectors are properly inserted.

1) INSPECTION PROCEDURE

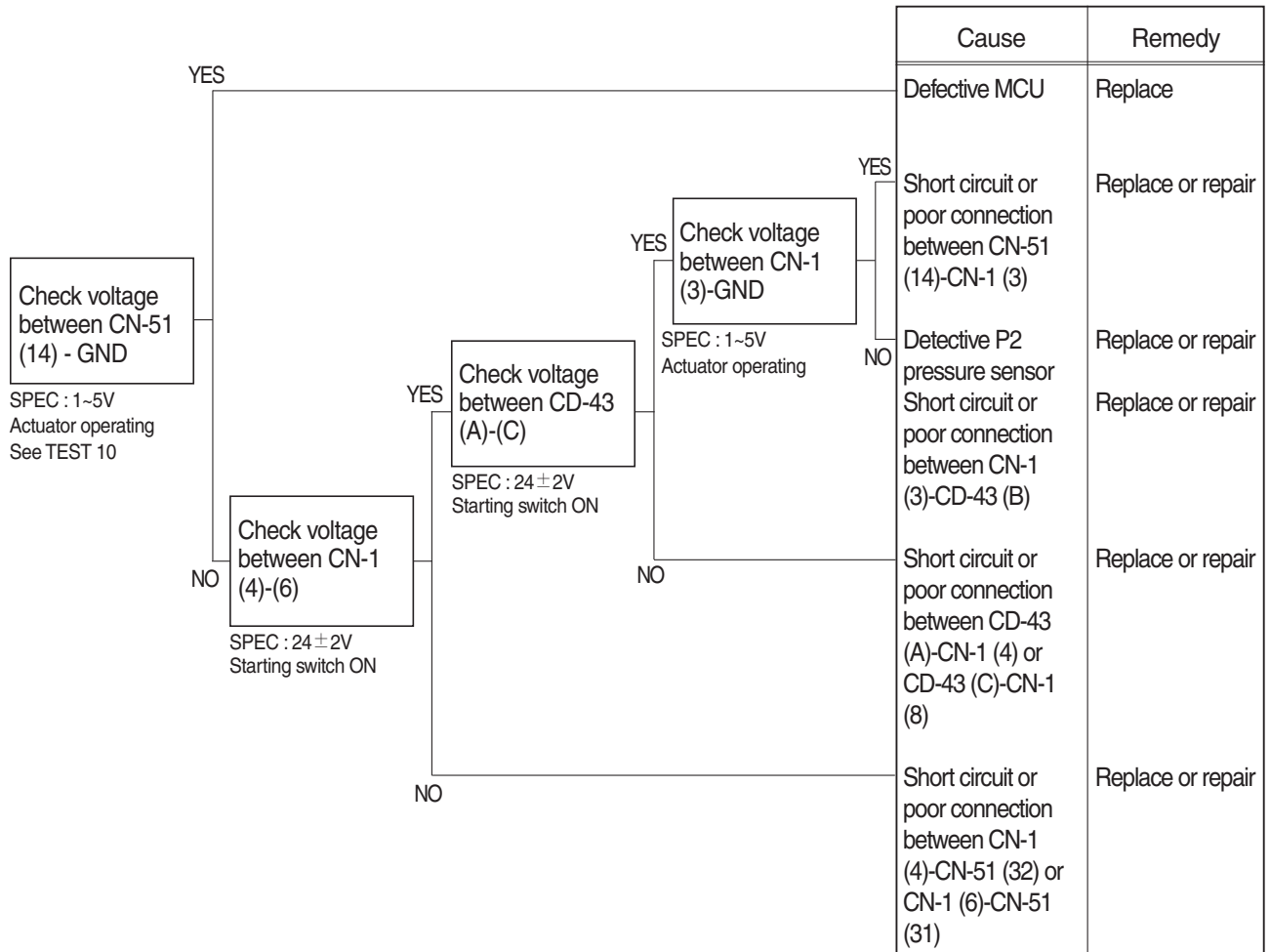

Wiring diagram

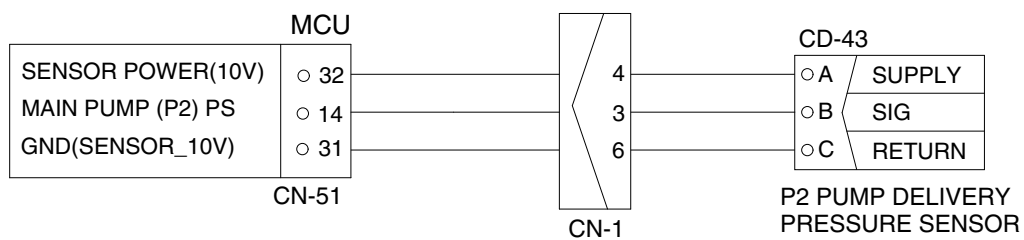

2) TEST PROCEDURE

(1) **Test 10** : Check voltage at CN-51 (14) and ground.

- ① Prepare 1 piece of thin sharp pin, steel or copper.
- ② Insert prepared pin to rear side of connectors : One pin to (14) of CN-51.
- ③ Starting switch ON.
- ④ Check voltage as figure.

SPEC : Actuator operating : 1~5 V

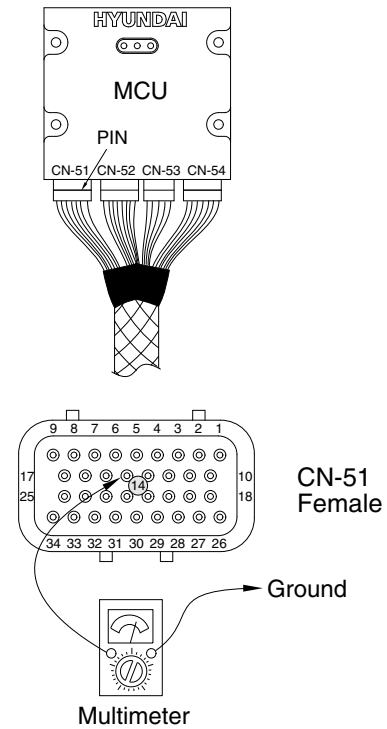

220A6MS108

7. MALFUNCTION OF NEGATIVE 1 PRESSURE SENSOR

· Fault code : HCESPN 123, FMI 0~4

※ Before carrying out below procedure, check all the related connectors are properly inserted.

1) INSPECTION PROCEDURE

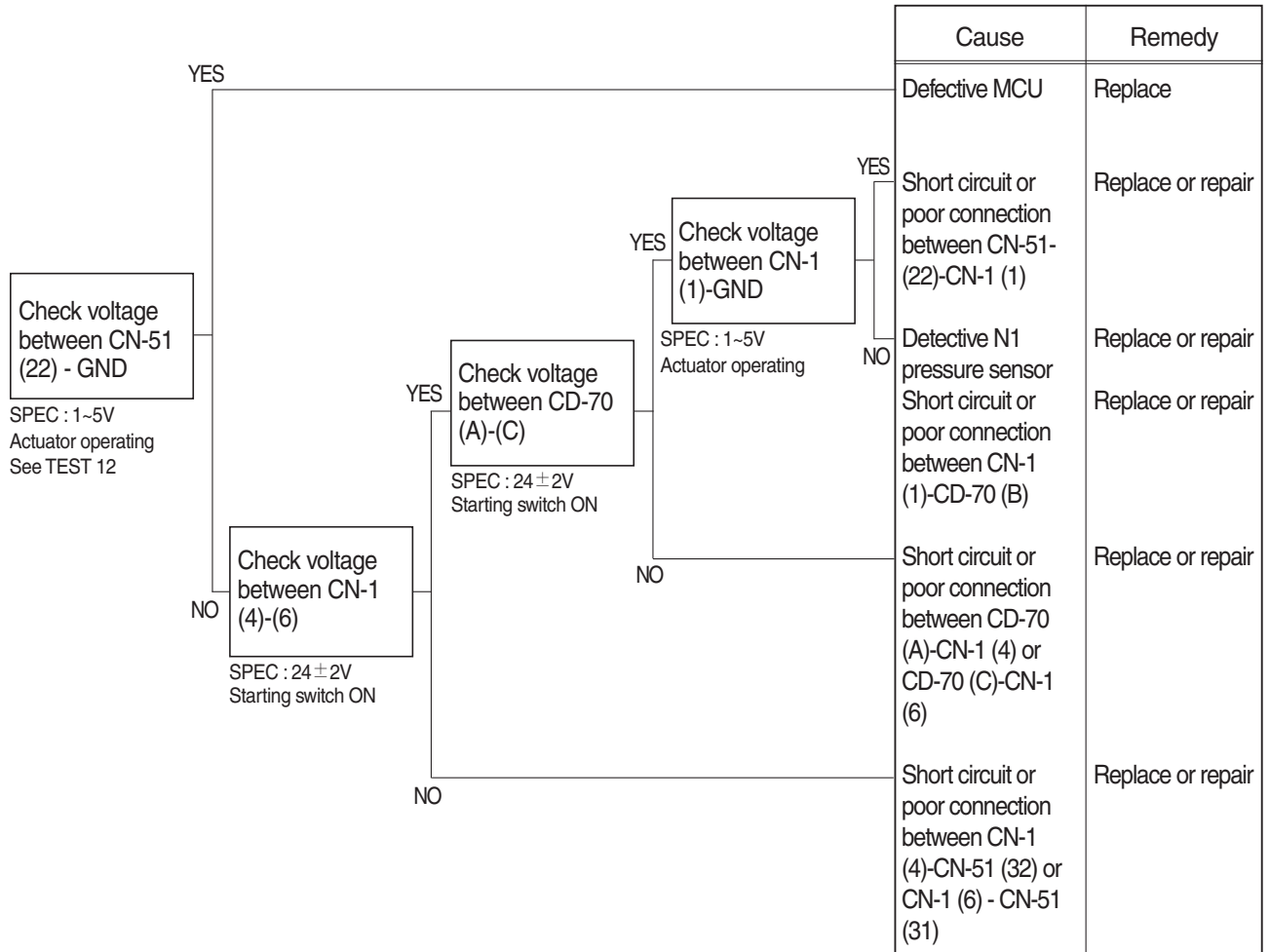

Wiring diagram

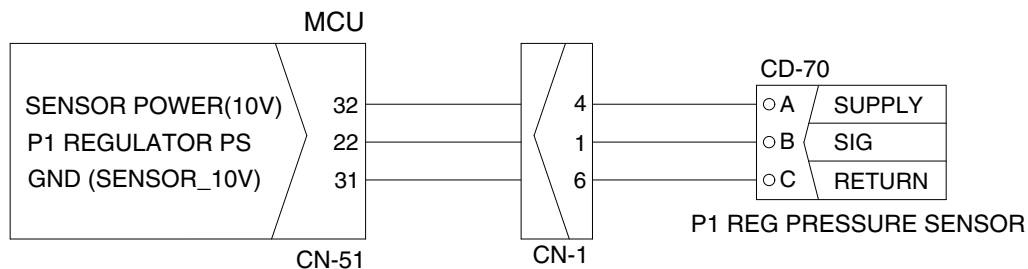

160A6MS11

2) TEST PROCEDURE

(1) **Test 12** : Check voltage at CN-51 (22) and ground.

- ① Prepare 1 piece of thin sharp pin, steel or copper.
- ② Insert prepared pin to rear side of connectors : One pin to (22) of CN-51.
- ③ Starting switch ON.
- ④ Check voltage as figure.

SPEC : Actuator operating : 1~5 V

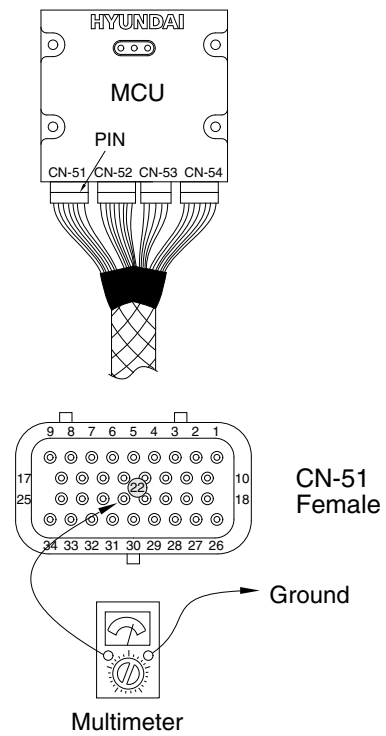

140L6MS112

8. MALFUNCTION OF NEGATIVE 2 PRESSURE SENSOR

· Fault code : HCESPN 124, FMI 0~4

※ Before carrying out below procedure, check all the related connectors are properly inserted.

1) INSPECTION PROCEDURE

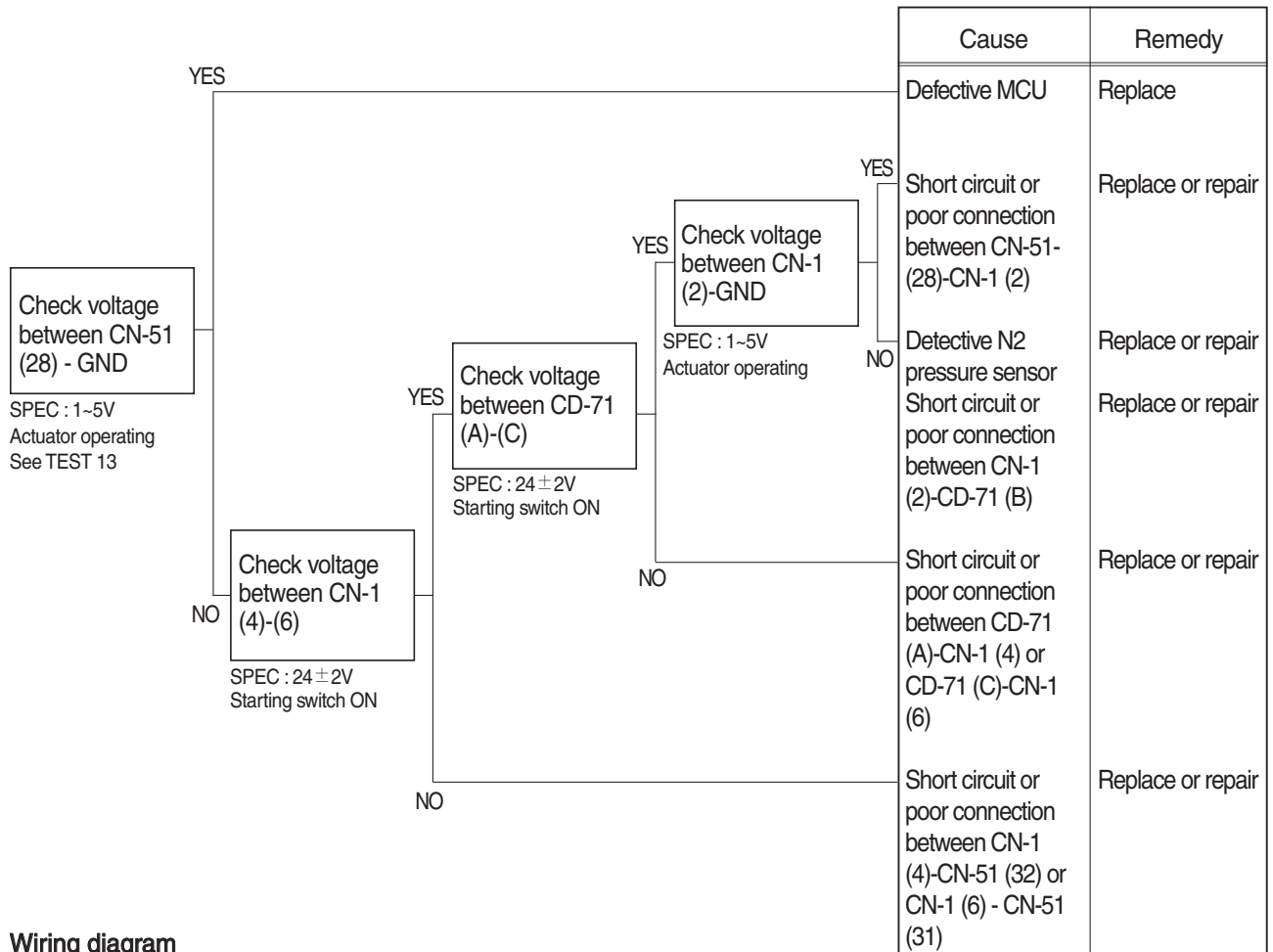

Wiring diagram

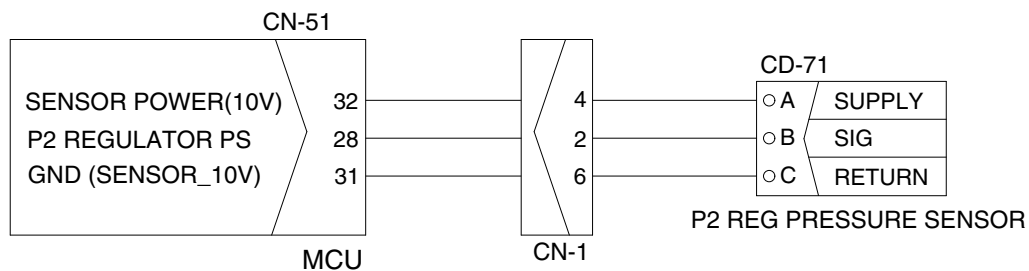

160A6MS13

2) TEST PROCEDURE

(1) **Test 13** : Check voltage at CN-51 (28) and ground.

- ① Prepare 1 piece of thin sharp pin, steel or copper.
- ② Insert prepared pin to rear side of connectors : One pin to (28) of CN-51.
- ③ Starting switch ON.
- ④ Check voltage as figure.

SPEC : Actuator operating : 1~5 V

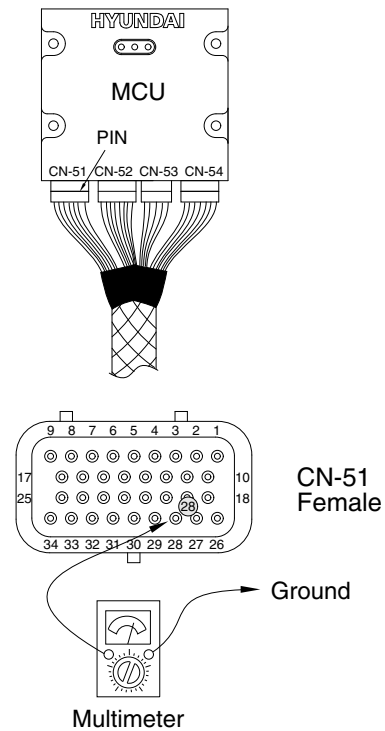

140L6MS114

9. MALFUNCTION OF SWING PRESSURE SENSOR

· Fault code : HCESPN 135, FMI 0~4

※ Before carrying out below procedure, check all the related connectors are properly inserted.

1) INSPECTION PROCEDURE

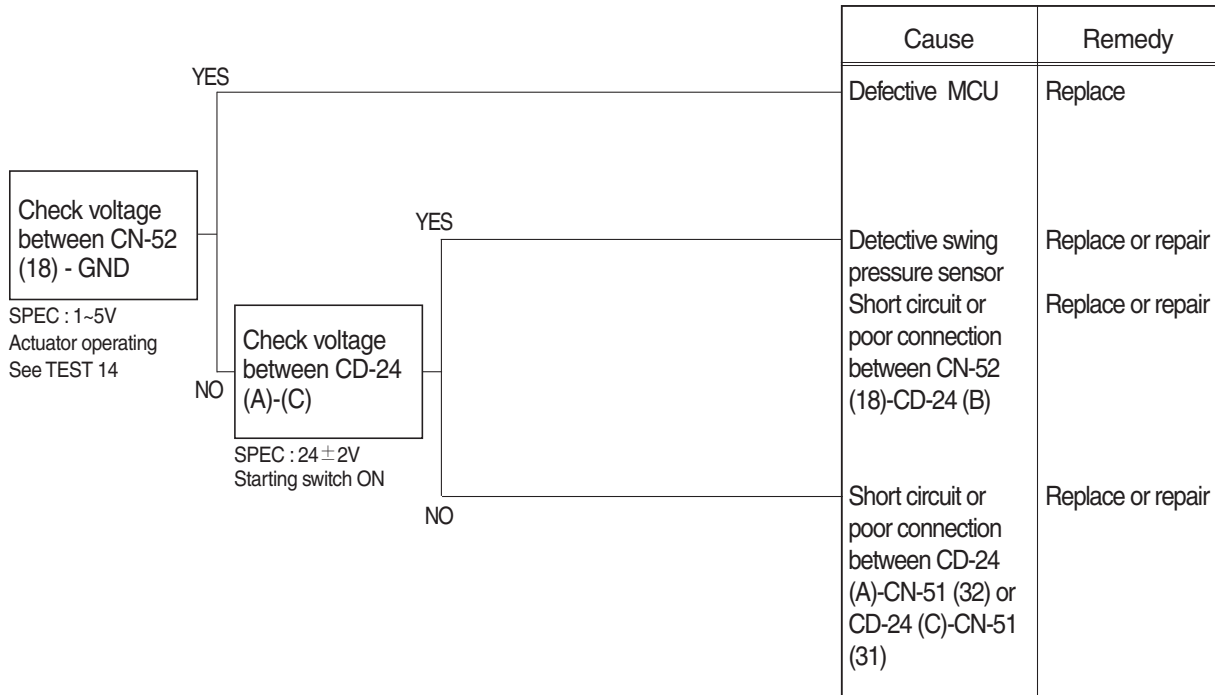

Wiring diagram

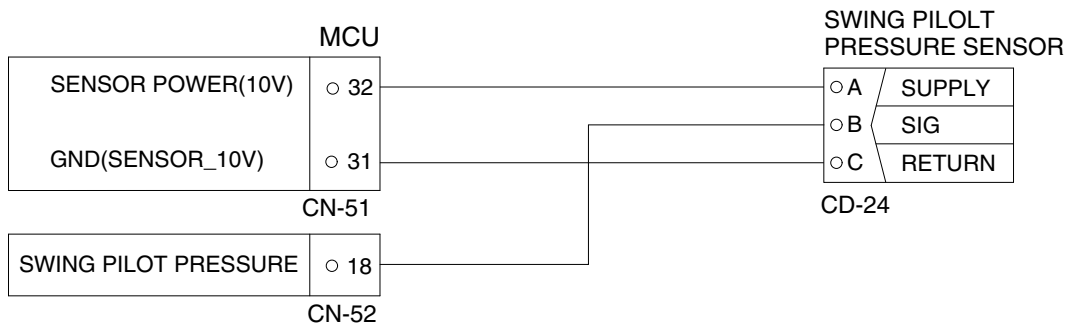

160A6MS14

2) TEST PROCEDURE

(1) **Test 14** : Check voltage at CN-52 (18) and ground.

- ① Prepare 1 piece of thin sharp pin, steel or copper.
- ② Insert prepared pin to rear side of connectors : One pin to (18) of CN-52.
- ③ Starting switch ON.
- ④ Check voltage as figure.

SPEC : Actuator operating : 1~5 V

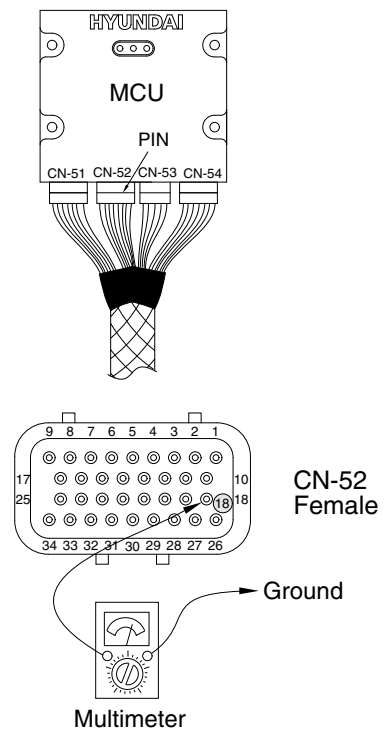

220A6MS116

10. MALFUNCTION OF ARM OUT PRESSURE SENSOR

· Fault code : HCESPN 133, FMI 0~4

※ Before carrying out below procedure, check all the related connectors are properly inserted.

1) INSPECTION PROCEDURE

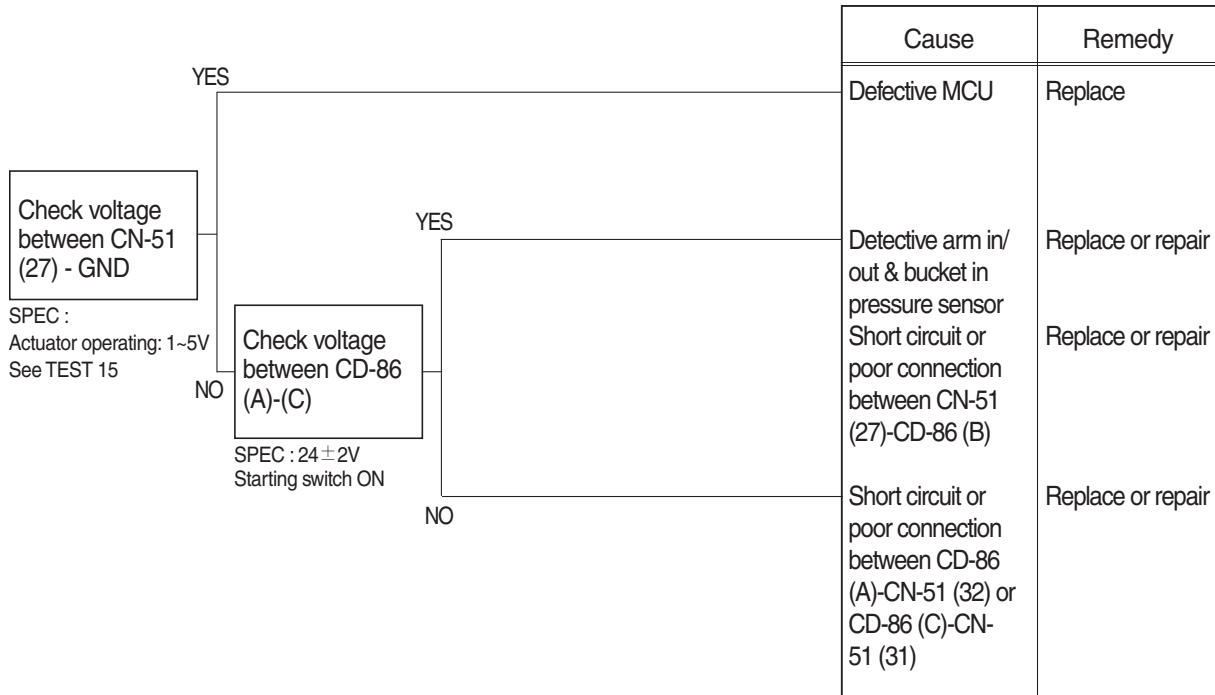

Wiring diagram

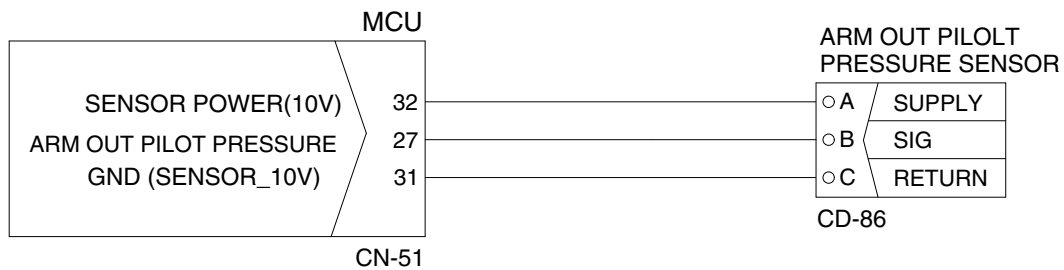

160A6MS17

2) TEST PROCEDURE

(1) **Test 15** : Check voltage at CN-51 (27) and ground.

- ① Prepare 1 piece of thin sharp pin, steel or copper.
- ② Insert prepared pin to rear side of connectors : One pin to (27) of CN-51.
- ③ Starting switch ON.
- ④ Check voltage as figure.

SPEC : Actuator operating : 1~5 V

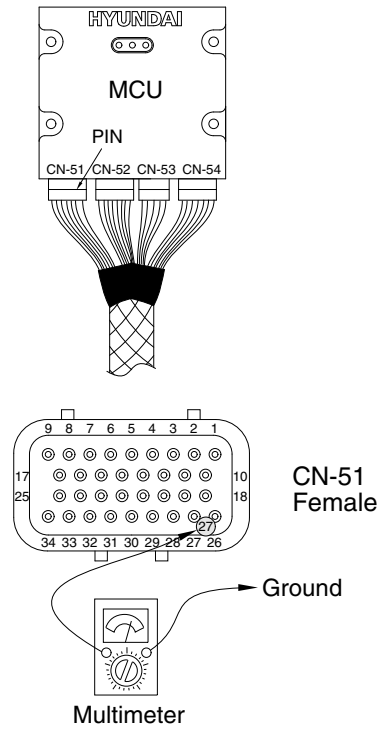

220A6MS118

11. MALFUNCTION OF BOOM UP PRESSURE SENSOR

· Fault code : HCESPN 127, FMI 0~4

※ Before carrying out below procedure, check all the related connectors are properly inserted.

1) INSPECTION PROCEDURE

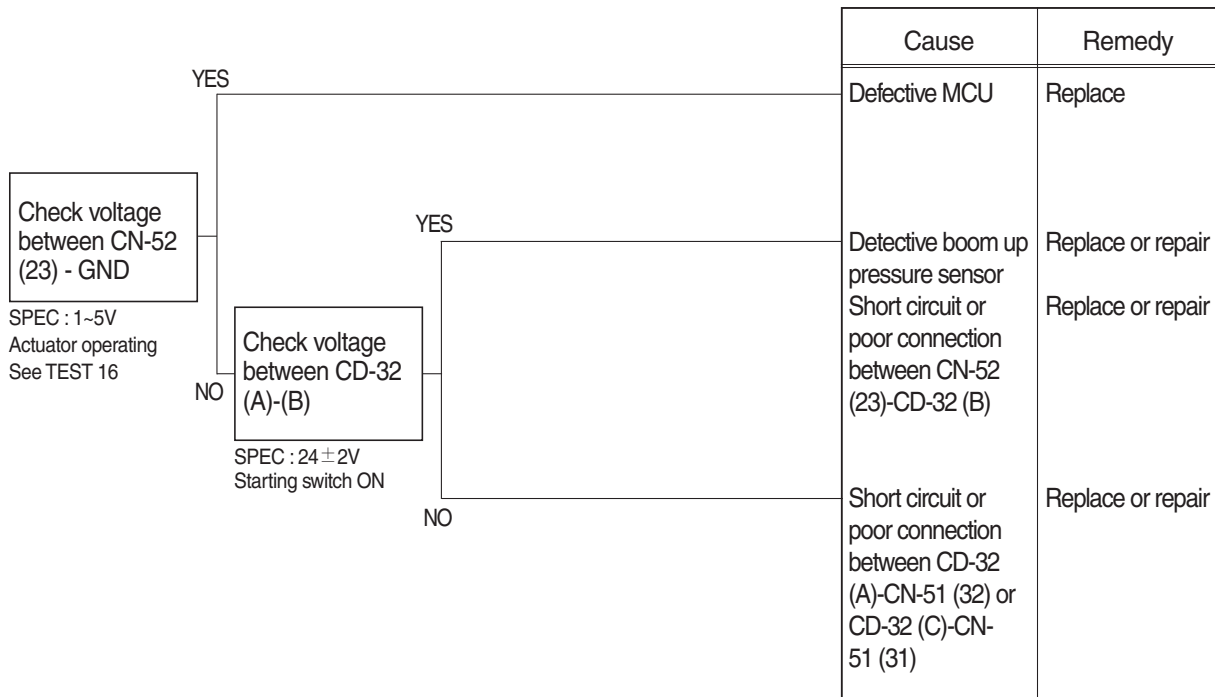

Wiring diagram

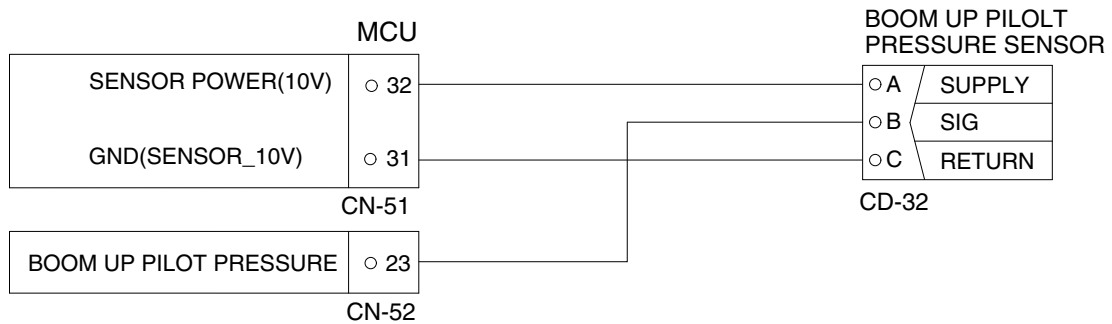

2) TEST PROCEDURE

(1) **Test 16** : Check voltage at CN-52 (23) and ground.

- ① Prepare 1 piece of thin sharp pin, steel or copper.
- ② Insert prepared pin to rear side of connectors : One pin to (23) of CN-52.
- ③ Starting switch ON.
- ④ Check voltage as figure.

SPEC : Actuator operating : 1~5 V

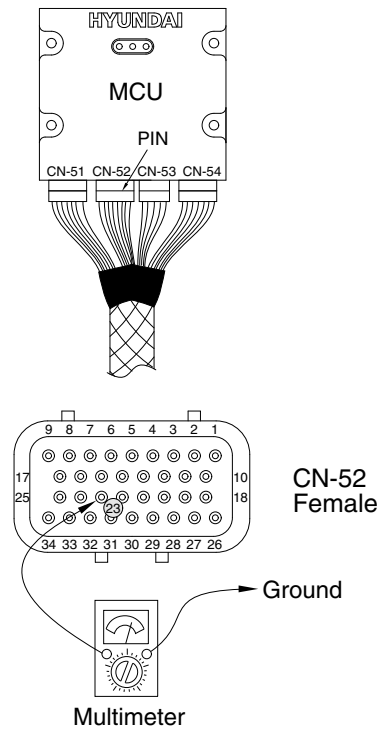

220A6MS120

12. MALFUNCTION OF BOOM DOWN PRESSURE SENSOR

· Fault code : HCESPN 128, FMI 0~4

※ Before carrying out below procedure, check all the related connectors are properly inserted.

1) INSPECTION PROCEDURE

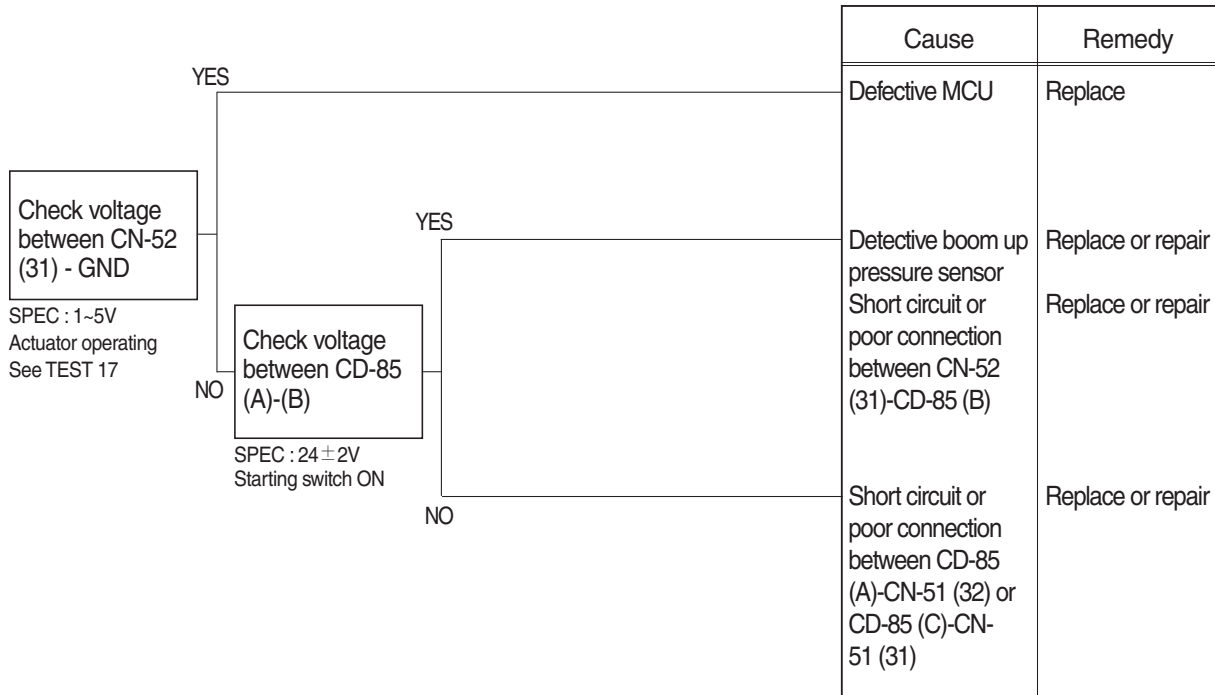

Wiring diagram

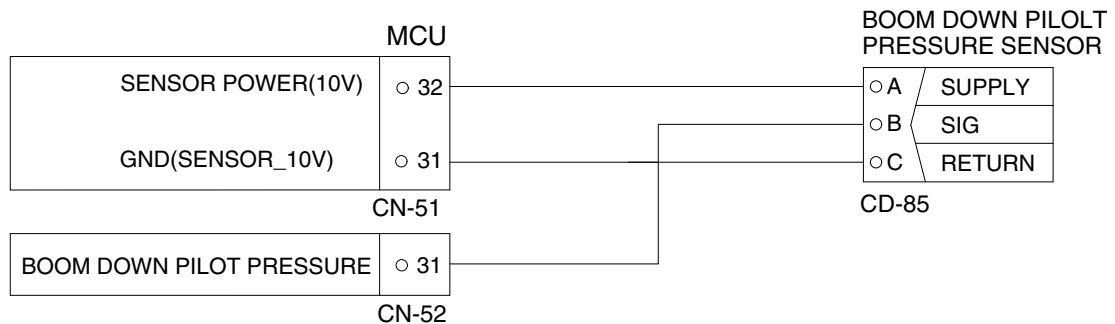

160A6MS21

2) TEST PROCEDURE

(1) **Test 17** : Check voltage at CN-52 (31) and ground.

- ① Prepare 1 piece of thin sharp pin, steel or copper.
- ② Insert prepared pin to rear side of connectors : One pin to (31) of CN-52.
- ③ Starting switch ON.
- ④ Check voltage as figure.

SPEC : Actuator operating : 1~5 V

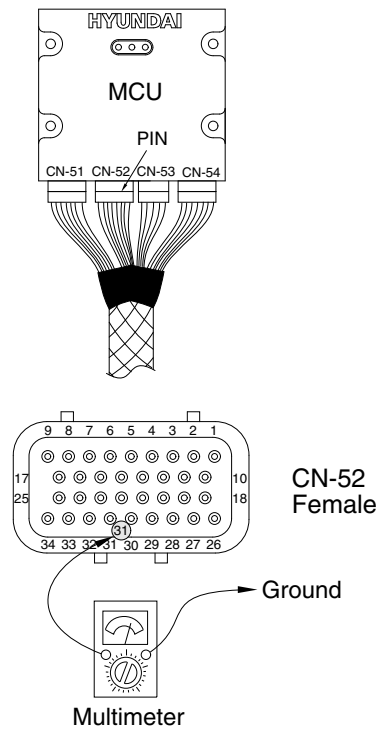

220A6MS122

13. MALFUNCTION OF POWER MAX

· Fault code : HCESPN 166, FMI 4 or 6

※ Before carrying out below procedure, check all the related connectors are properly inserted.

1) INSPECTION PROCEDURE

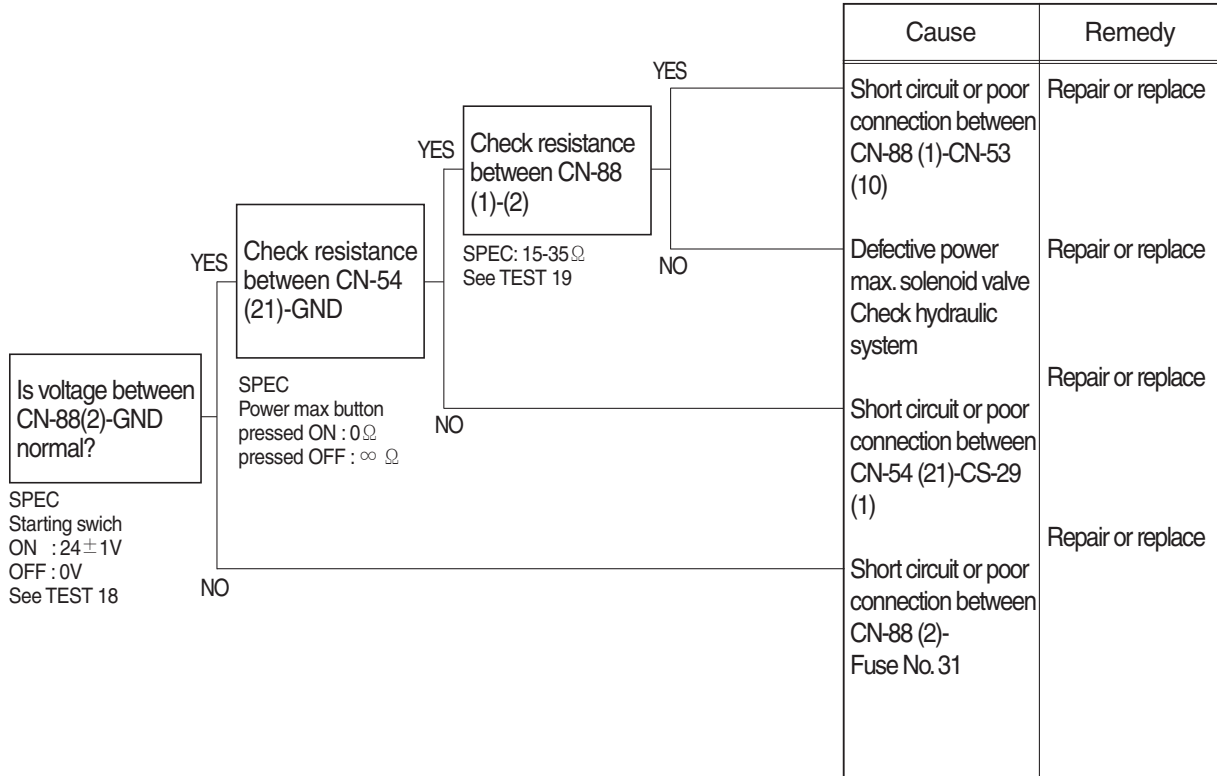

Wiring diagram

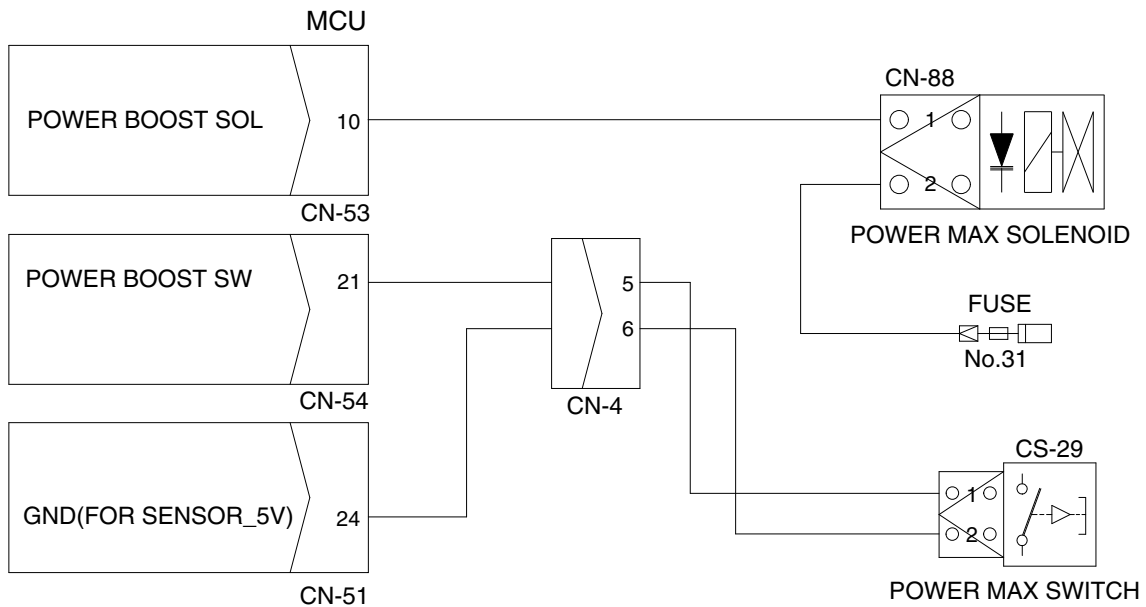

160A6MS22

2) TEST PROCEDURE

(1) **Test 18:** Check voltage between connector CN-88 (2) - GND.

- ① Disconnect connector CN-88 from power max solenoid valve.
- ② Start switch ON.
- ③ Check voltage as figure.

SPEC : Starting switch ON : $24 \pm 1V$
Starting switch OFF : $0V$

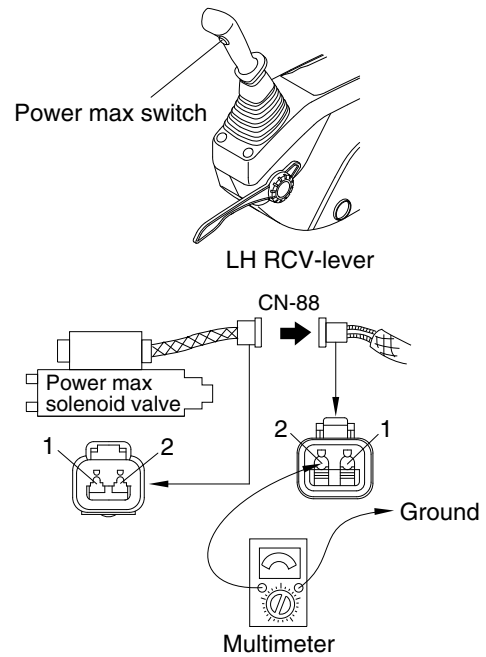

140L6MS123

(2) **Test 19:** Check resistance of the solenoid valve between CN-88 (1)-(2).

- ① Starting switch OFF.
- ② Disconnect connector CN-88 from power max solenoid valve.
- ③ Check resistance as figure.

SPEC : $15 \sim 35 \Omega$

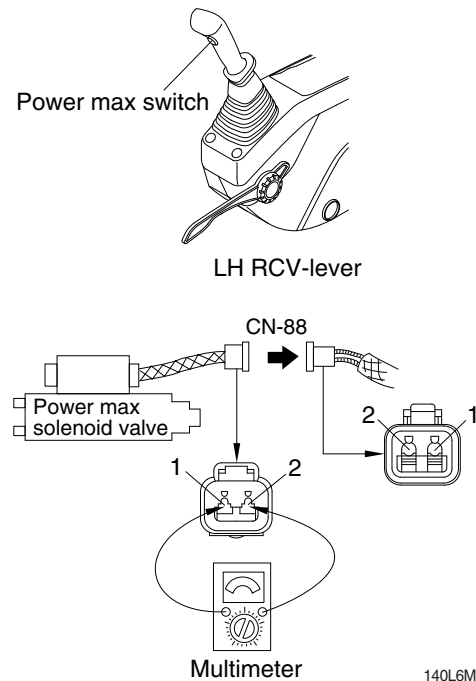

140L6MS124

14. MALFUNCTION OF BOOM PRIORITY EPPR VALVE

· Fault code : HCESPN 141, FMI 5 or 6

※ Before carrying out below procedure, check all the related connectors are properly inserted.

1) INSPECTION PROCEDURE

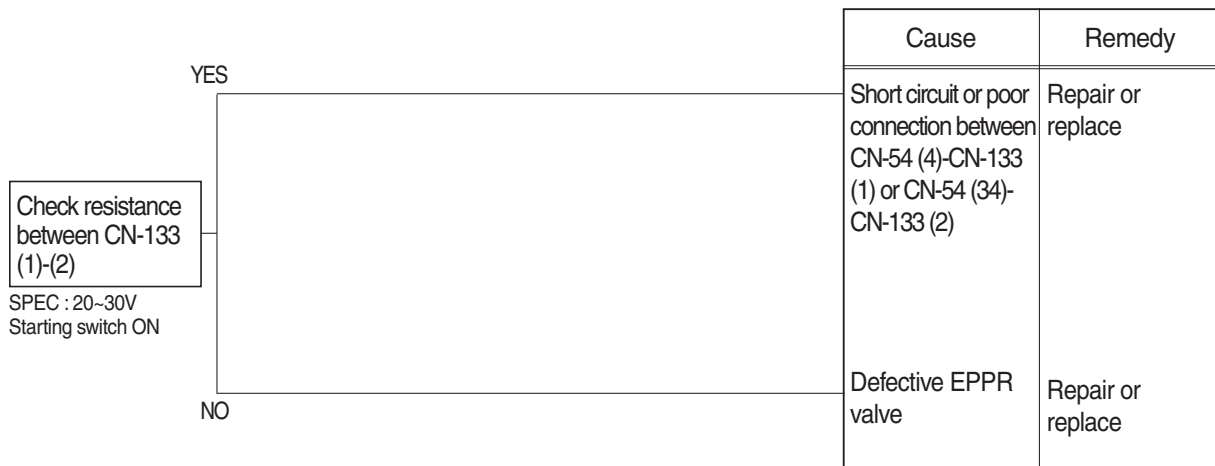

Wiring diagram

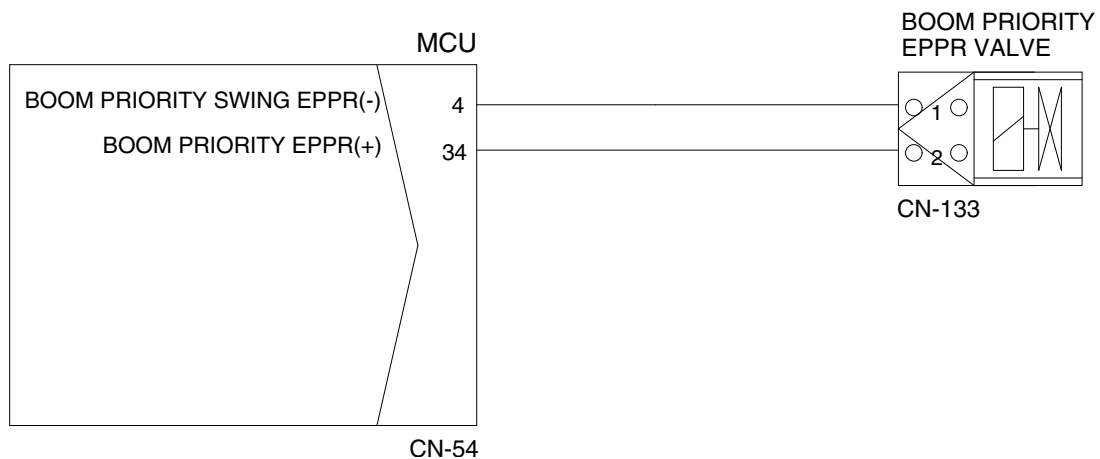

160A6MS23

15. MALFUNCTION OF ARM REGENERATION SOLENOID

· Fault code : HCESPN 170, FMI 4 or 6

※ Before carrying out below procedure, check all the related connectors are properly inserted.

1) INSPECTION PROCEDURE

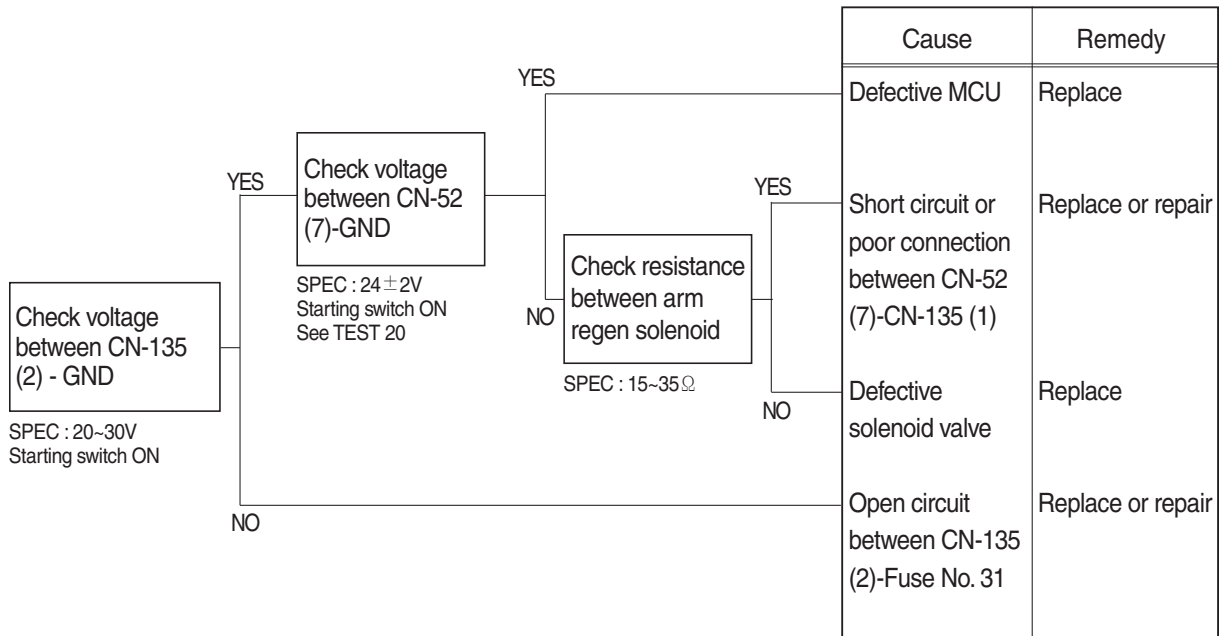

Wiring diagram

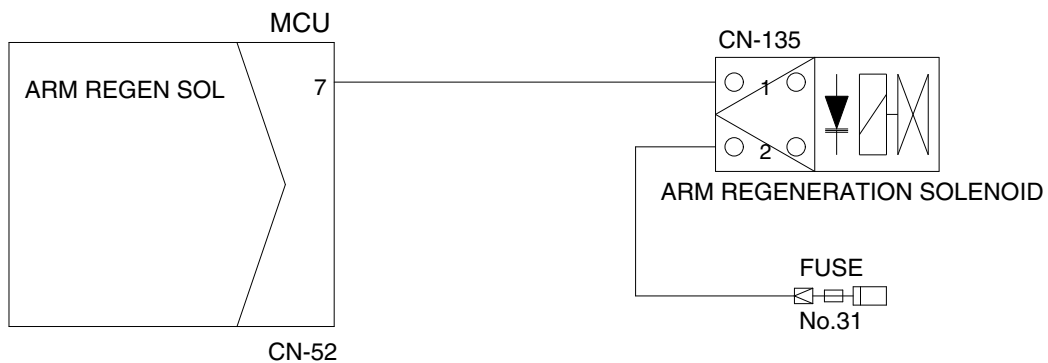

160A6MS27

2) TEST PROCEDURE

(1) **Test 20** : Check voltage at CN-52 (7) and ground.

- ① Prepare 1 piece of thin sharp pin, steel or copper.
- ② Insert prepared pin to rear side of connectors : One pin to (7) of CN-52.
- ③ Starting switch ON.
- ④ Check voltage as figure.

SPEC : Key ON : 24 ± 2 V

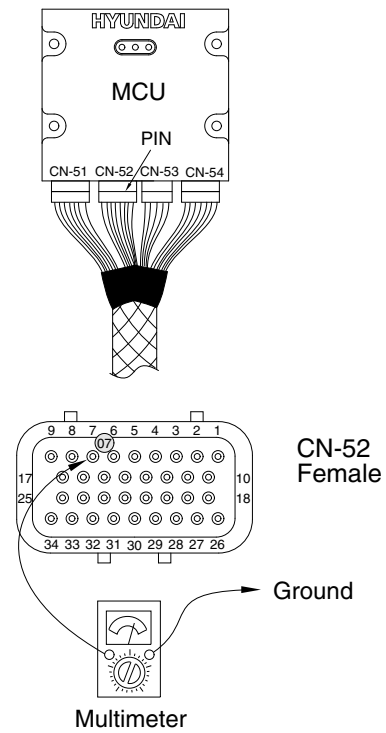

140L6MS128

GROUP 5 AIR CONDITIONER & HEATER SYSTEM

1. AIR CONDITIONER DOES NOT OPERATE

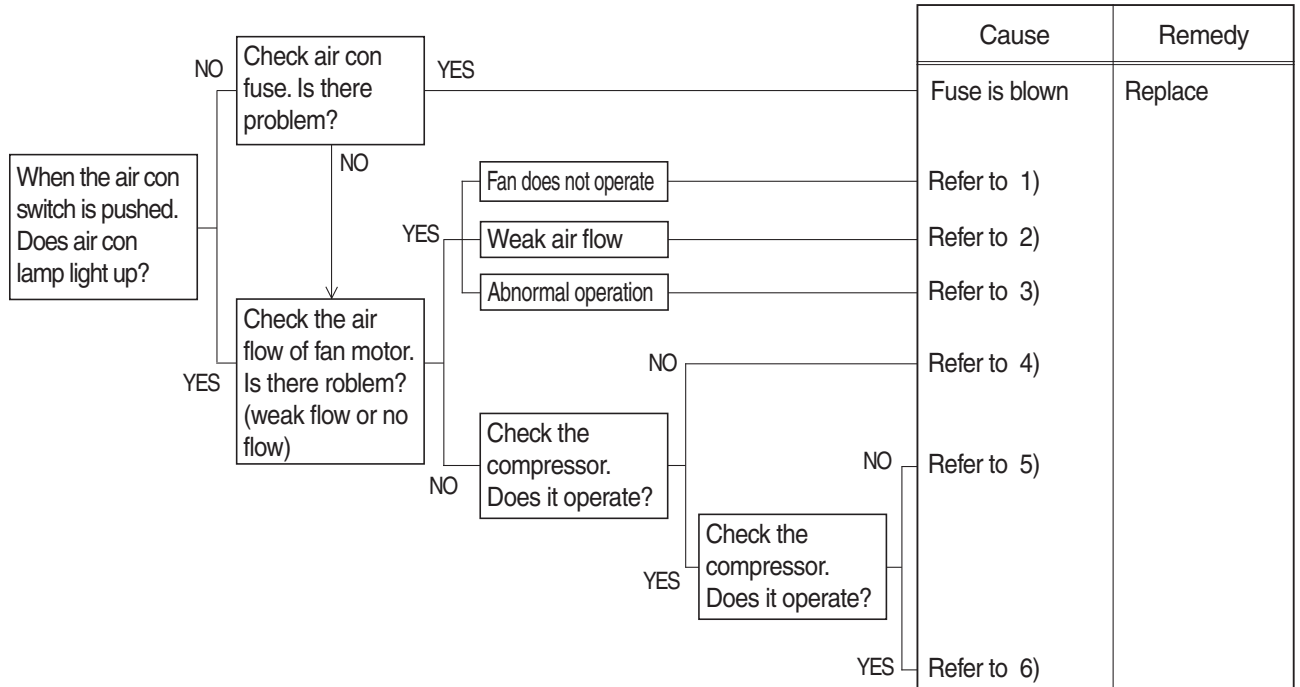

1) FAN DOES NOT OPERATE

| Cause | Check | Remedy |
|---|--|-----------------|
| Fuse is blown or abnormal relay operation | * Fuse * Does relay normally operate? | Replace |
| Harness short or poor contact | Check any harness short or abnormal contact of connector | Repair shortage |
| Fan motor failure | Supply 24V to 2 lead wire from motor and check the operation | Replace |
| Resistor is broken | Check current flow of resistor with tester | Replace |
| Fan switch failure | Push fan switch by turn and check the operation | Replace |

2) WEAK AIR FLOW FROM FAN MOTOR

| Cause | Check | Remedy |
|--|-------------------------------------|---------|
| Clogged evaporator or obstacles around air inlet | Check if evaporator is contaminated | Clean |
| Leakage of air flow | Check HVAC case assembly | Adjust |
| Duct sensor failure | Check if evaporator is frozen | Replace |

3) ABNORMAL OPERATION OF FAN MOTOR

| Cause | Check | Remedy |
|--|------------------------------|------------------|
| Abnormal operation of each step of control | 4 step only operate | Replace resistor |
| | 1 or 2 step does not operate | Replace control |
| | 3 or 4 step does not operate | Replace relay |

4) COMPRESSOR DOES NOT ROTATE OR HARDLY ROTATE

| Cause | Check | Remedy |
|--------------------------------------|---|--|
| Loose belt | Belt shaking is severe | Adjust tension |
| Failure of compressor itself | Belt slip | Repair or Replace |
| Low voltage of battery | Slip when rotate | Charge battery |
| Fieldcoil short | Slip when rotate | Replace magnetic clutch |
| Oily clutch face | Contamination around clutch | Replace magnetic clutch, clean |
| Fieldcoil is broken | Magnetic clutch does not operate or " ∞ " resistance | Replace compressor |
| Leakage of refrigerant or oil inside | Check if wet with oil | Replace compressor Charge refrigerant |

5) COMPRESSOR OPERATE NORMALLY AND AIR FLOW IS NORMAL

| Cause | Check | Remedy |
|--|--|--|
| Shortage of refrigerant | When air con operate during 5~10 min small temperature difference between high and low pressure pipes. | Repair leakage joint Charge refrigerant |
| Overcharge of refrigerant | *Magnetic clutch on/off rapidly *High pressure over specification *Lukewarm air from nozzle | Recharge refrigerant following specification |
| Lower pressure than normal condition at low side | Shortage of refrigerant | Make up refrigerant |
| | Clogged receive dryer | Replace receive dryer |
| | Clogged expansion valve | Replace expansion valve |
| | Clogged or crushed pipe | Replace pipe or clean |
| | Failure of duct sensor | Replace duct sensor |

6) COMPRESSOR OPERATE NORMALLY AND AIR FLOW IS NORMAL

| Cause | Check | Remedy |
|--|--|--|
| Lower pressure than normal condition at low side | Failure of duct sensor Magnetic clutch off before air temperature sufficiently down | Replace duct sensor or adjust location |
| | Defective compressor gasket When compressor off, high and low pressure balance immediatly | Repair compressor or Replace |
| Higher pressure than normal condition at high side | Failure of condensing Contamination on condenser or insufficient air flow from fan | Clean the condenser Repair fan |
| | Overcharge of refrigerant | Adjust refrigerant |
| | Entrained air | Vacuum and recharge |
| Lower pressure than normal condition at high side | Shortage of refrigerant | Make up refrigerant |