

SECTION 8 DISASSEMBLY AND ASSEMBLY

Group 1	Precaution	8-1
Group 2	Tightening Torque	8-4
Group 3	Pump Device	8-7
Group 4	Main Control Valve	8-29
Group 5	Swing Device (type 1)	8-43
Group 5	Swing Device (type 2)	8-68
Group 6	Travel Device	8-98
Group 7	RCV Lever	8-130
Group 8	Turning Joint	8-144
Group 9	Boom, Arm and Bucket Cylinder	8-149
Group 10	Undercarriage	8-167
Group 11	Work Equipment	8-179

SECTION 8 DISASSEMBLY AND ASSEMBLY

GROUP 1 PRECAUTIONS

1. REMOVAL WORK

- 1) Lower the work equipment completely to the ground.
If the coolant contains antifreeze, dispose of it correctly.
- 2) After disconnecting hoses or tubes, cover them or fit blind plugs to prevent dirt or dust from entering.
- 3) When draining oil, prepare a container of adequate size to catch the oil.
- 4) Confirm the match marks showing the installation position, and make match marks in the necessary places before removal to prevent any mistake when assembling.
- 5) To prevent any excessive force from being applied to the wiring, always hold the connectors when disconnecting the connectors.
- 6) Fit wires and hoses with tags to show their installation position to prevent any mistake when installing.
- 7) Check the number and thickness of the shims, and keep in a safe place.
- 8) When raising components, be sure to use lifting equipment of ample strength.
- 9) When using forcing screws to remove any components, tighten the forcing screws alternately.
- 10) Before removing any unit, clean the surrounding area and fit a cover to prevent any dust or dirt from entering after removal.
- 11) When removing hydraulic equipment, first release the remaining pressure inside the hydraulic tank and the hydraulic piping.
- 12) If the part is not under hydraulic pressure, the following corks can be used.

Nominal number	Dimensions		
	D	d	L
06	6	5	8
08	8	6.5	11
10	10	8.5	12
12	12	10	15
14	14	11.5	18
16	16	13.5	20
18	18	15	22
20	20	17	25
22	22	18.5	28
24	24	20	30
27	27	22.5	34

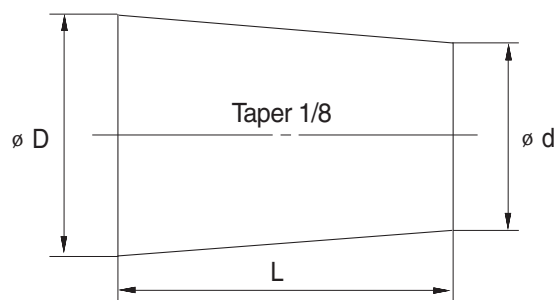

2. INSTALL WORK

- 1) Tighten all bolts and nuts (sleeve nuts) to the specified torque.
- 2) Install the hoses without twisting or interference.
- 3) Replace all gaskets, O-rings, cotter pins, and lock plates with new parts.
- 4) Bend the cotter pin or lock plate securely.
- 5) When coating with adhesive, clean the part and remove all oil and grease, then coat the threaded portion with 2-3 drops of adhesive.
- 6) When coating with gasket sealant, clean the surface and remove all oil and grease, check that there is no dirt or damage, then coat uniformly with gasket sealant.
- 7) Clean all parts, and correct any damage, dents, burrs, or rust.
- 8) Coat rotating parts and sliding parts with engine oil.
- 9) When press fitting parts, coat the surface with antifriction compound (LM-P).
- 10) After installing snap rings, check that the snap ring is fitted securely in the ring groove (Check that the snap ring moves in the direction of rotation).
- 11) When connecting wiring connectors, clean the connector to remove all oil, dirt, or water, then connect securely.
- 12) When using eyebolts, check that there is no deformation or deterioration, and screw them in fully.
- 13) When tightening split flanges, tighten uniformly in turn to prevent excessive tightening on one side.
- 14) When operating the hydraulic cylinders for the first time after repairing and reassembling the hydraulic cylinders, pumps, or other hydraulic equipment or piping, always bleed the air from the hydraulic cylinders as follows:
 - (1) Start the engine and run at low idling.
 - (2) Operate the control lever and actuate the hydraulic cylinder 4-5 times, stopping 100mm before the end of the stroke.
 - (3) Next, operate the piston rod to the end of its stroke to relieve the circuit. (The air bleed valve is actuated to bleed the air.)
 - (4) After completing this operation, raise the engine speed to the normal operating condition.
 - ※ If the hydraulic cylinder has been replaced, carry out this procedure before assembling the rod to the work equipment. Carry out the same operation on machines that have been in storage for a long time after completion of repairs.

3. COMPLETING WORK

- 1) If the coolant has been drained, tighten the drain valve, and add water to the specified level. Run the engine to circulate the water through the system. Then check the water level again.
- 2) If the hydraulic equipment has been removed and installed again, add engine oil to the specified level. Run the engine to circulate the oil through the system. Then check the oil level again.
- 3) If the piping or hydraulic equipment, such as hydraulic cylinders, pumps, or motors, have been removed for repair, always bleed the air from the system after reassembling the parts.
- 4) Add the specified amount of grease (molybdenum disulphied grease) to the work equipment related parts.

GROUP 2 TIGHTENING TORQUE

1. MAJOR COMPONENTS (HX160 L)

No.	Descriptions	Bolt size	Torque		
			kgf · m	lbf · ft	
1	Engine	Engine mounting bolt (engine-bracket, FR)	M12 × 1.75	11.2 ± 1.1	81 ± 8.0
2		Engine mounting bolt (engine-bracket, RR)	M12 × 1.75	7.9 ± 2.0	57.1 ± 14.5
3		Engine mounting bolt (bracket-frame, FR)	M16 × 2.0	34.0 ± 4.0	246 ± 28.9
4		Engine mounting bolt (bracket-frame, RR)	M16 × 2.0	34.0 ± 4.0	246 ± 28.9
5		Radiator mounting bolt	M16 × 2.0	29.7 ± 4.5	215 ± 32.5
6		Coupling mounting socket bolt	M16 × 2.0	32.0 ± 1.6	231 ± 11.6
7		Main pump housing mounting bolt	M10 × 1.5	6.0 ± 1.5	43.4 ± 10.9
8	Hydraulic system	Main pump mounting socket bolt	M16 × 2.0	22.0 ± 1.5	159 ± 10.9
9		Main control valve mounting bolt	M12 × 1.75	12.2 ± 1.3	88.2 ± 9.4
10		Fuel tank mounting bolt	M20 × 2.5	46.0 ± 5.0	333 ± 36.9
11		Hydraulic oil tank mounting bolt	M20 × 2.5	46.0 ± 5.0	333 ± 36.9
12		Turning joint mounting bolt, nut	M12 × 1.75	12.3 ± 1.3	89.0 ± 9.4
13	Power train system	Swing motor mounting bolt	M20 × 2.5	57.9 ± 8.7	419 ± 62.9
14		Swing bearing upper part mounting bolt	M20 × 2.5	57.9 ± 6.0	419 ± 49.9
15		Swing bearing lower part mounting bolt	M20 × 2.5	57.9 ± 6.0	419 ± 49.9
16		Travel motor mounting bolt	M16 × 2.0	23.0 ± 2.5	166 ± 18.1
17		Sprocket mounting bolt	M16 × 2.0	29.7 ± 3.0	215 ± 21.7
18	Under carriage	Carrier roller mounting bolt, nut	M16 × 2.0	29.7 ± 3.0	215 ± 21.7
19		Track roller mounting bolt	M16 × 2.0	29.7 ± 3.0	215 ± 21.7
20		Track tension cylinder mounting bolt	M16 × 2.0	21.9 ± 3.3	158 ± 23.9
21		Track shoe mounting bolt, nut	5/8 - 18UNF	42.0 ± 4.0	304 ± 28.9
22		Track guard mounting bolt	M20 × 2.5	57.9 ± 8.7	419 ± 62.9
23	Others	Counterweight mounting bolt	M30 × 3.5	199 ± 30	1439 ± 217
24		Cab mounting bolt	M12 × 1.75	12.8 ± 3.0	92.6 ± 21.7
25		Operator's seat mounting bolt	M 8 × 1.25	4.05 ± 0.8	29.3 ± 5.8

2. MAJOR COMPONENTS (HX180 L)

No.	Descriptions	Bolt size	Torque		
			kgf · m	lbf · ft	
1	Engine	Engine mounting bolt (engine-bracket, FR)	M12 × 1.75	11.2 ± 1.1	81 ± 8.0
2		Engine mounting bolt (engine-bracket, RR)	M12 × 1.75	7.9 ± 2.0	57.1 ± 14.5
3		Engine mounting bolt (bracket-frame, FR)	M16 × 2.0	34.0 ± 4.0	246 ± 28.9
4		Engine mounting bolt (bracket-frame, RR)	M16 × 2.0	34.0 ± 4.0	246 ± 28.9
5		Radiator mounting bolt	M16 × 2.0	29.7 ± 4.5	215 ± 32.5
6		Coupling mounting socket bolt	M16 × 2.0	32.0 ± 1.6	231 ± 11.6
7		Main pump housing mounting bolt	M10 × 1.5	6.0 ± 1.5	43.4 ± 10.9
8	Hydraulic system	Main pump mounting socket bolt	M16 × 2.0	22.0 ± 1.5	159 ± 10.9
9		Main control valve mounting bolt	M12 × 1.75	12.2 ± 1.3	88.2 ± 9.4
10		Fuel tank mounting bolt	M20 × 2.5	46.0 ± 5.0	333 ± 36.9
11		Hydraulic oil tank mounting bolt	M20 × 2.5	46.0 ± 5.0	333 ± 36.9
12		Turning joint mounting bolt, nut	M12 × 1.75	12.3 ± 1.3	89.0 ± 9.4
13	Power train system	Swing motor mounting bolt	M20 × 2.5	57.9 ± 8.7	419 ± 62.9
14		Swing bearing upper part mounting bolt	M20 × 2.5	57.9 ± 6.0	419 ± 49.9
15		Swing bearing lower part mounting bolt	M20 × 2.5	57.9 ± 6.0	419 ± 49.9
16		Travel motor mounting bolt	M16 × 2.0	23.0 ± 2.5	166 ± 18.1
17		Sprocket mounting bolt	M16 × 2.0	29.7 ± 3.0	215 ± 21.7
18	Under carriage	Carrier roller mounting bolt, nut	M16 × 2.0	29.7 ± 3.0	215 ± 21.7
19		Track roller mounting bolt	M 20 × 2.5	57.9 ± 6.0	419 ± 43.4
20		Track tension cylinder mounting bolt	M16 × 2.0	21.9 ± 3.3	158 ± 23.9
21		Track shoe mounting bolt, nut	5/8 - 18UNF	42.0 ± 4.0	304 ± 28.9
22		Track guard mounting bolt	M20 × 2.5	57.9 ± 8.7	419 ± 62.9
23	Others	Counterweight mounting bolt	M30 × 3.5	199 ± 30	1439 ± 217
24		Cab mounting bolt	M12 × 1.75	12.8 ± 3.0	92.6 ± 21.7
25		Operator's seat mounting bolt	M 8 × 1.25	4.05 ± 0.8	29.3 ± 5.8

3. TORQUE CHART

Use following table for unspecified torque.

1) BOLT AND NUT

(1) Coarse thread

Bolt size	8.8T		10.9T		12.9T	
	kgf·m	lbf·ft	kgf·m	lbf·ft	kgf·m	lbf·ft
M 6 × 1.0	0.8 ~ 1.2	5.8 ~ 8.6	1.2 ~ 1.8	8.7 ~ 13.0	1.5 ~ 2.1	10.9 ~ 15.1
M 8 × 1.25	2.0 ~ 3.0	14.5 ~ 21.6	2.8 ~ 4.2	20.3 ~ 30.4	3.4 ~ 5.0	24.6 ~ 36.1
M10 × 1.5	4.0 ~ 6.0	29.0 ~ 43.3	5.6 ~ 8.4	40.5 ~ 60.8	6.8 ~ 10.0	49.2 ~ 72.3
M12 × 1.75	6.8 ~ 10.2	50.0 ~ 73.7	9.6 ~ 14.4	69.5 ~ 104	12.3 ~ 16.5	89.0 ~ 119
M14 × 2.0	10.9 ~ 16.3	78.9 ~ 117	16.3 ~ 21.9	118 ~ 158	19.5 ~ 26.3	141 ~ 190
M16 × 2.0	17.9 ~ 24.1	130 ~ 174	25.1 ~ 33.9	182 ~ 245	30.2 ~ 40.8	141 ~ 295
M18 × 2.5	24.8 ~ 33.4	180 ~ 241	34.8 ~ 47.0	252 ~ 340	41.8 ~ 56.4	302 ~ 407
M20 × 2.5	34.9 ~ 47.1	253 ~ 340	49.1 ~ 66.3	355 ~ 479	58.9 ~ 79.5	426 ~ 575
M22 × 2.5	46.8 ~ 63.2	339 ~ 457	65.8 ~ 88.8	476 ~ 642	78.9 ~ 106	570 ~ 766
M24 × 3.0	60.2 ~ 81.4	436 ~ 588	84.6 ~ 114	612 ~ 824	102 ~ 137	738 ~ 991
M30 × 3.5	120 ~ 161	868 ~ 1164	168 ~ 227	1216 ~ 1641	202 ~ 272	1461 ~ 1967

(2) Fine thread

Bolt size	8.8T		10.9T		12.9T	
	kgf · m	lbf · ft	kgf · m	lbf · ft	kgf · m	lbf · ft
M 8 × 1.0	2.1 ~ 3.1	15.2 ~ 22.4	3.0 ~ 4.4	21.7 ~ 31.8	3.6 ~ 5.4	26.1 ~ 39.0
M10 × 1.25	4.2 ~ 6.2	30.4 ~ 44.9	5.9 ~ 8.7	42.7 ~ 62.9	7.0 ~ 10.4	50.1 ~ 75.2
M12 × 1.25	7.3 ~ 10.9	52.8 ~ 78.8	10.3 ~ 15.3	74.5 ~ 110	13.1 ~ 17.7	94.8 ~ 128
M14 × 1.5	12.4 ~ 16.6	89.7 ~ 120	17.4 ~ 23.4	126 ~ 169	20.8 ~ 28.0	151 ~ 202
M16 × 1.5	18.7 ~ 25.3	136 ~ 182	26.3 ~ 35.5	191 ~ 256	31.6 ~ 42.6	229 ~ 308
M18 × 1.5	27.1 ~ 36.5	196 ~ 264	38.0 ~ 51.4	275 ~ 371	45.7 ~ 61.7	331 ~ 446
M20 × 1.5	37.7 ~ 50.9	273 ~ 368	53.1 ~ 71.7	384 ~ 518	63.6 ~ 86.0	460 ~ 622
M22 × 1.5	51.2 ~ 69.2	370 ~ 500	72.0 ~ 97.2	521 ~ 703	86.4 ~ 116	625 ~ 839
M24 × 2.0	64.1 ~ 86.5	464 ~ 625	90.1 ~ 121	652 ~ 875	108 ~ 146	782 ~ 1056
M30 × 2.0	129 ~ 174	933 ~ 1258	181 ~ 245	1310 ~ 1772	217 ~ 294	1570 ~ 2126

2) PIPE AND HOSE (FLARE TYPE)

Thread size (PF)	Width across flat (mm)	kgf · m	lbf · ft
1/4"	19	4	28.9
3/8"	22	5	36.2
1/2"	27	9.5	68.7
3/4"	36	18	130.2
1"	41	21	151.9
1-1/4"	50	35	253.2

3) PIPE AND HOSE (ORFS TYPE)

Thread size (UNF)	Width across flat (mm)	kgf · m	lbf · ft
9/16-18	19	4	28.9
11/16-16	22	5	36.2
13/16-16	27	9.5	68.7
1-3/16-12	36	18	130.2
1-7/16-12	41	21	151.9
1-11/16-12	50	35	253.2

4) FITTING

Thread size	Width across flat (mm)	kgf · m	lbf · ft
1/4"	19	4	28.9
3/8"	22	5	36.2
1/2"	27	9.5	68.7
3/4"	36	18	130.2
1"	41	21	151.9
1-1/4"	50	35	253.2

GROUP 3 PUMP DEVICE

1. REMOVAL AND INSTALL

1) REMOVAL

- (1) Lower the work equipment to the ground and stop the engine.
- (2) Operate the control levers and pedals several times to release the remaining pressure in the hydraulic piping
- (3) Loosen the breather slowly to release the pressure inside the hydraulic tank.

▲ Escaping fluid under pressure can penetrate the skin causing serious injury.

- (4) Loosen the drain plug under the hydraulic tank and drain the oil from the hydraulic tank.

· Hydraulic tank quantity : 125 l (33.0 U.S. gal)

- (5) Remove socket bolts (11) and disconnect hoses (1, 2).
- (6) Disconnect pilot line hoses (5, 6, 7, 8, 9, 10).

- (7) Remove socket bolts (12) and disconnect pump suction pipe (4).

※ When pump suction tube is disconnected, the oil inside the piping will flow out, so catch it in oil pan.

- (8) Sling the pump assembly and remove the pump mounting bolts.

· Weight : 89 kg (200 lb)

※ Pull out the pump assembly from housing.

When removing the pump assembly, check that all the hoses have been disconnected.

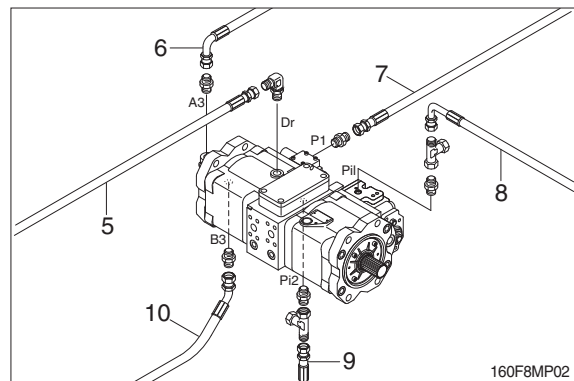
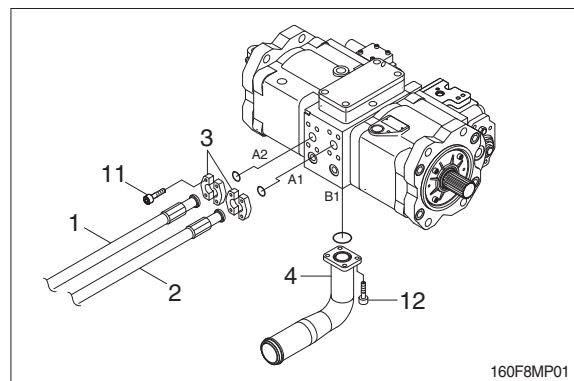

2) INSTALL

- (1) Carry out installation in the reverse order to removal.
- (2) Remove the suction strainer and clean it.
- (3) Replace return filter with new one.
- (4) Remove breather and clean it.
- (5) After adding oil to the hydraulic tank to the specified level.
- (6) Bleed the air from the hydraulic pump.
 - ① Remove the air vent plug (2 EA).
 - ② Tighten plug lightly.
 - ③ Start the engine, run at low idling, and check oil come out from plug.
 - ④ Tighten plug.
- (7) Start the engine, run at low idling (3~5 minutes) to circulate the oil through the system.
- (8) Confirm the hydraulic oil level and check the hydraulic oil leak or not.

2. MAIN PUMP (1/2)

1) STRUCTURE

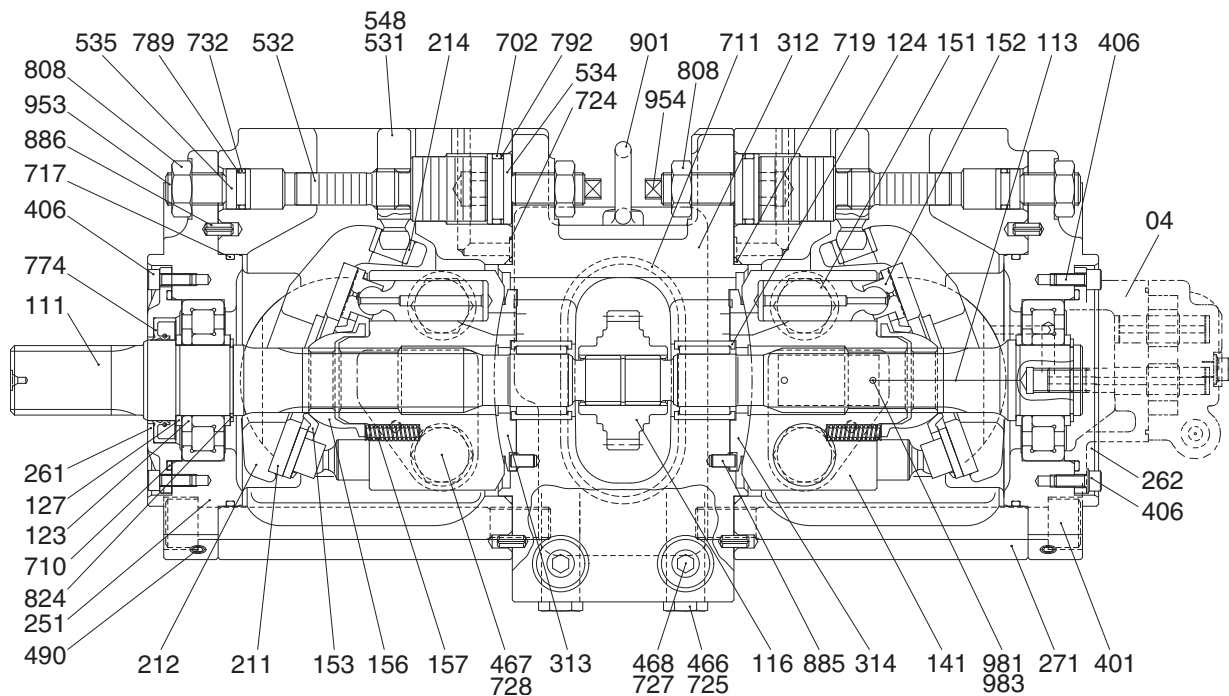



14092MP02

04	Gear pump	312	Valve block	717	O-ring
111	Drive shaft (F)	313	Valve plate (R)	719	O-ring
113	Drive shaft (R)	314	Valve plate (L)	724	O-ring
116	1st Gear	326	Cover	725	O-ring
123	Roller bearing	401	Hexagon socket bolt	727	O-ring
124	Needle bearing	406	Hexagon socket bolt	728	O-ring
127	Bearing spacer	414	Hexagon socket bolt	732	O-ring
141	Cylinder block	466	Plug	774	Oil seal
151	Piston	467	plug	789	Back up ring
152	Shoe	468	Plug	792	Back up ring
153	Set plate	490	Plug	808	Hexagon head nut
156	Bushing	531	Tilting pin	824	Snap ring
157	Cylinder spring	532	Servo piston	885	Pin
211	Shoe plate	534	Stopper (L)	886	Spring pin
212	Swash plate	535	Stopper (S)	901	Eye bolt
251	Support	548	Pin	953	Set screw
261	Seal cover (F)	702	O-ring	954	Set screw
271	Pump casing	710	O-ring	981	Plate
		711	O-ring	983	Pin

2) TOOLS AND TIGHTENING TORQUE

(1) Tools

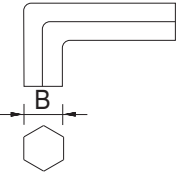
The tools necessary to disassemble/reassemble the pump are shown in the follow list.

Tool name & size		Part name			
Name	B	Hexagon socket head bolt	PT plug (PT thread)	PO plug (PF thread)	Hexagon socket head setscrew
Allen wrench 	4	M 5	BP-1/16	-	M 8
	5	M 6	BP-1/8	-	M10
	6	M 8	BP-1/4	PO-1/4	M12, M14
	8	M10	BP-3/8	PO-3/8	M16, M18
	17	M20, M22	BP-1	PO-1, 1 1/4, 1 1/2	-
Double ring spanner, socket wrench, double (single) open end spanner 	-	Hexagon bolt	Hexagon nut	VP plug (PF thread)	
	19	M12	M12	VP-1/4	
	24	M16	M16	-	
	27	M18	M18	VP-1/2	
	30	M20	M20	-	
	36	-	-	VP-3/4	
Adjustable angle wrench		Medium size, 1 set			
Screw driver		Minus type screw driver, Medium size, 2 sets			
Hammer		Plastic hammer, 1 set			
Pliers		For snap ring, TSR-160			
Steel bar		Steel bar of key material approx. 10 × 8 × 200			
Torque wrench		Capable of tightening with the specified torques			

(2) Tightening torque

Part name	Bolt size	Torque		Wrench size	
		kgf · m	lbf · ft	in	mm
Hexagon socket head bolt (material : SCM435)	M 5	0.7	5.1	0.16	4
	M 6	1.2	8.7	0.20	5
	M 8	3.0	21.7	0.24	6
	M10	5.8	42.0	0.31	8
	M12	10.0	72.3	0.39	10
	M14	16.0	116	0.47	12
	M16	24.0	174	0.55	14
	M18	34.0	246	0.55	14
PT Plug (material : S45C) ※ Wind a seal tape 1 1/2 to 2 turns round the plug	PT1/16	0.7	5.1	0.16	4
	PT 1/8	1.05	7.59	0.20	5
	PT 1/4	1.75	12.7	0.24	6
	PT 3/8	3.5	25.3	0.31	8
	PT 1/2	5.0	36.2	0.39	10
PF Plug (material : S45C)	PF 1/4	3.0	21.7	0.24	6
	PF 1/2	10.0	72.3	0.39	10
	PF 3/4	15.0	109	0.55	14
	PF 1	19.0	137	0.67	17
	PF 1 1/4	27.0	195	0.67	17
	PF 1 1/2	28.0	203	0.67	17

3) DISASSEMBLY

- (1) Select place suitable to disassembling.
 - ※ Select clean place.
 - ※ Spread rubber sheet, cloth or so on on overhaul workbench top to prevent parts from being damaged.
- (2) Remove dust, rust, etc, from pump surfaces with cleaning oil or so on.
- (3) Remove drain port plug (468) and let oil out of pump casing (front and rear pump).
- (4) Remove hexagon socket head bolts (412, 413) and remove regulator.

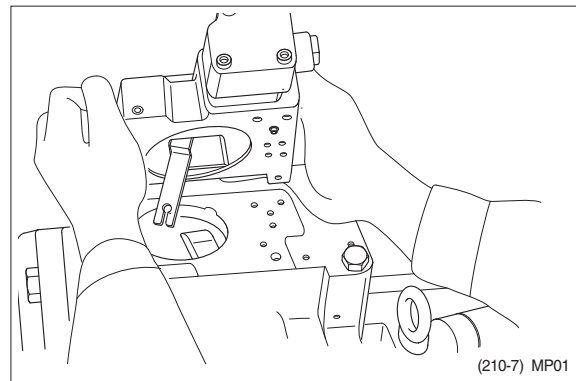

- (5) Loosen hexagon socket head bolts (401) which tighten swash plate support (251), pump casing (271) and valve block (312).
 - ※ If gear pump and so on are fitted to rear face of pump, remove them before starting this work.

- (6) Place pump horizontally on workbench with its regulator-fitting surface down and separate pump casing (271) from valve block (312).
 - ※ Before bringing this surface down, spread rubber sheet on workbench without fail to prevent this surface from being damaged.

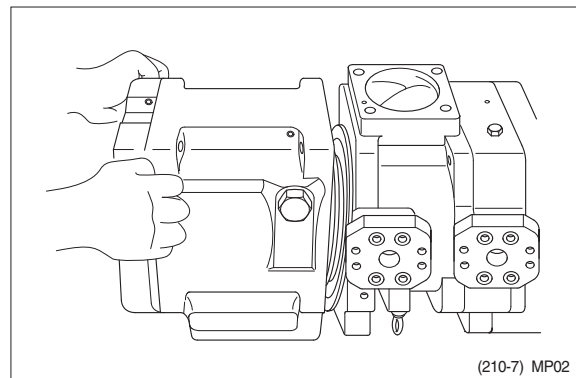

- (7) Pull cylinder block (141) out of pump casing (271) straightly over drive shaft (111). Pull out also pistons (151), set plate (153), spherical bush (156) and cylinder springs (157) simultaneously.

※ Take care not to damage sliding surfaces of cylinder, spherical bushing, shoes, swash plate, etc.

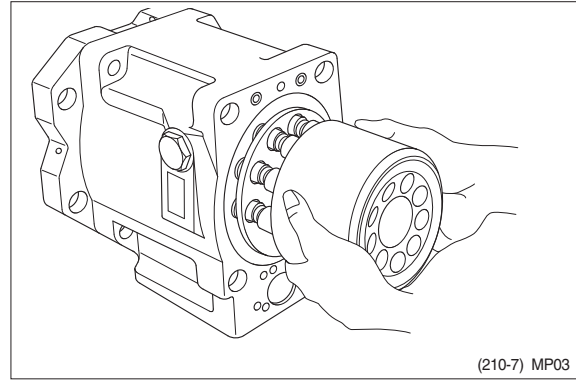

(210-7) MP03

- (8) Remove hexagon socket head bolts (406) and then seal cover (F, 261).

※ Fit bolt into pulling out tapped hole of seal cover (F), and cover can be removed easily.

※ Since oil seal is fitted on seal cover (F), take care not to damage it in removing cover.

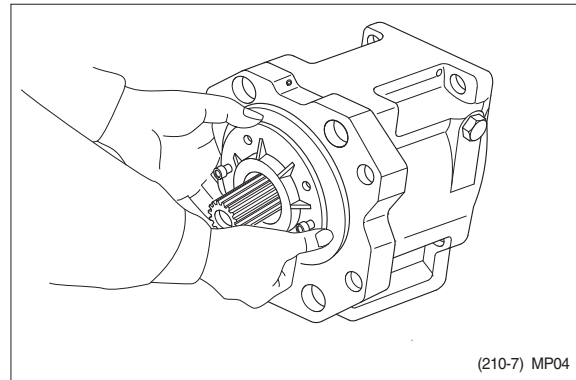

(210-7) MP04

- (9) Remove hexagon socket head bolts (408) and then seal cover (R, 262).

In case fitting a gear pump, first, remove gear pump.

- (10) Tapping lightly fitting flange section of swash plate support (251) on its pump casing side, separate swash plate support from pump casing.

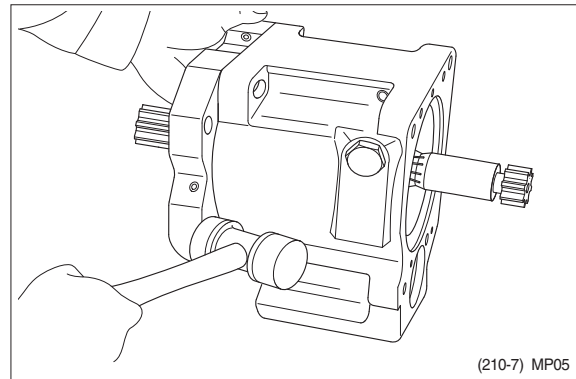

(210-7) MP05

- (11) Remove shoe plate (211) and swash plate (212) from pump casing (271).

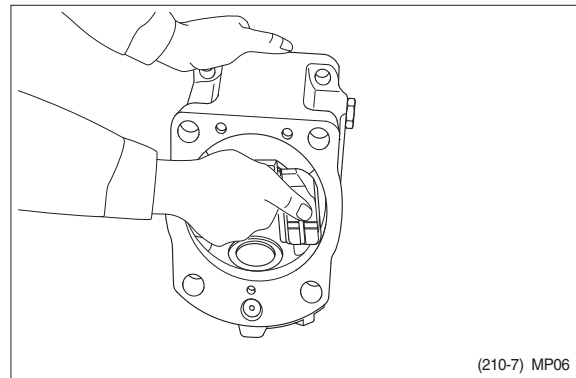

(210-7) MP06

- (12) Tapping lightly shaft ends of drive shafts (111, 113) with plastic hammer, take out drive shafts from swash plate supports.

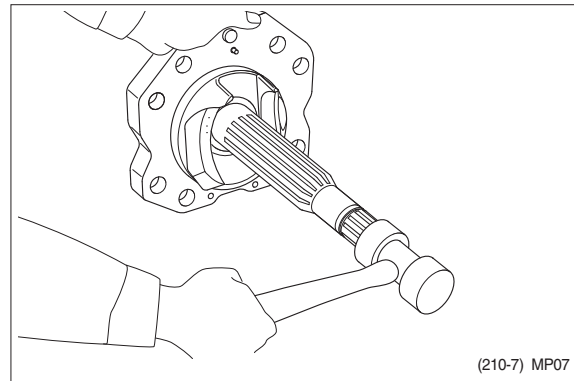

- (13) Remove valve plates (313, 314) from valve block (312).

※ These may be removed in work (6).

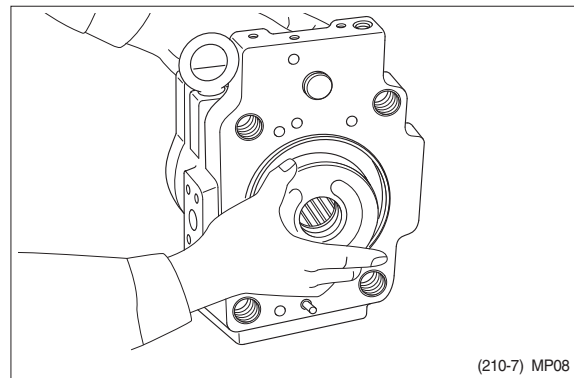

- (14) If necessary, remove stopper (L, 534), stopper (S, 535), servo piston (532) and tilting pin (531) from pump casing (271), and needle bearing (124) and splined coupling (114) from valve block (312).

- ※ In removing tilting pin, use a protector to prevent pin head from being damaged.
- ※ Since loctite is applied to fitting areas of tilting pin and servo piston, take care not to damage servo piston.
- ※ Do not remove needle bearing as far as possible, except when it is considered to be out of its life span.
- ※ Do not loosen hexagon nuts of valve block and swash plate support.
If loosened, flow setting will be changed.

4) ASSEMBLY

(1) For reassembling reverse the disassembling procedures, paying attention to the following items.

- ① Do not fail to repair the parts damaged during disassembling, and prepare replacement parts in advance.
- ② Clean each part fully with cleaning oil and dry it with compressed air.
- ③ Do not fail to apply clean working oil to sliding sections, bearings, etc. before assembling them.
- ④ In principle, replace seal parts, such as O-rings, oil seals, etc.
- ⑤ For fitting bolts, plug, etc., prepare a torque wrench or so on, and tighten them with torques shown in page 8-11, 12.
- ⑥ For the double-pump, take care not to mix up parts of the front pump with those of the rear pump.

(2) Fit swash plate support (251) to pump casing (271), tapping the former lightly with a hammer.

- ※ After servo piston, tilting pin, stopper (L) and stopper (S) are removed, fit them soon to pump casing in advance for reassembling.
- ※ In tightening servo piston and tilting pin, use a protector to prevent tilting pin head and feedback pin from being damaged. In addition, apply loctite (Medium strength) to their threaded sections.

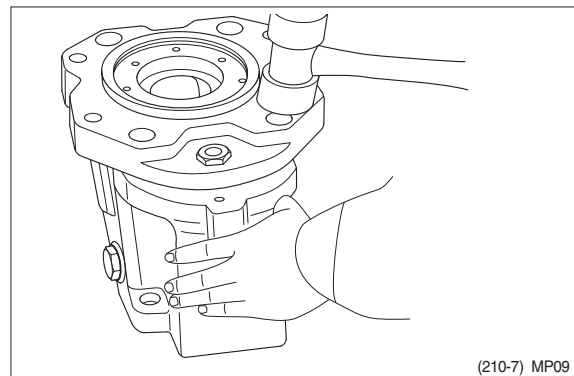

(210-7) MP09

(3) Place pump casing with its regulator fitting surface down, fit tilting bush of swash plate to tilting pin (531) and fit swash plate (212) to swash plate support (251) correctly.

- ※ Confirm with fingers of both hands that swash plate can be removed smoothly.
- ※ Apply grease to sliding sections of swash plate and swash plate support, and drive shaft can be fitted easily.

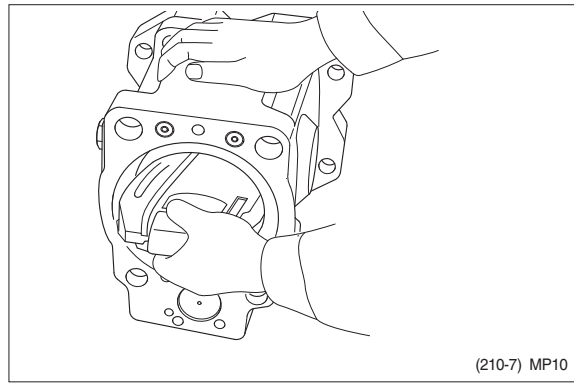

(210-7) MP10

(4) To swash plate support (251), fit drive shaft (111) set with bearing (123), bearing spacer (127) and snap ring (824).

- ※ Do not tap drive shaft with hammer or so on.
- ※ Assemble them into support, tapping outer race of bearing lightly with plastic hammer.
- Fit them fully, using steel bar or so on.

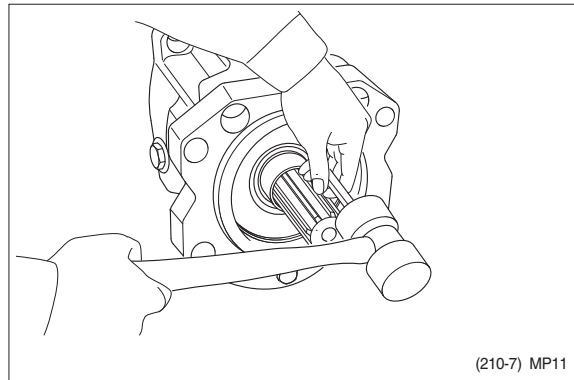

(210-7) MP11

(5) Assemble seal cover (F, 261) to pump casing (271) and fix it with hexagon socket head bolts (406).

- ※ Apply grease lightly to oil seal in seal cover (F).
- ※ Assemble oil seal, taking full care not to damage it.
- ※ For tandem type pump, fit rear cover (263) and seal cover (262) similarly.

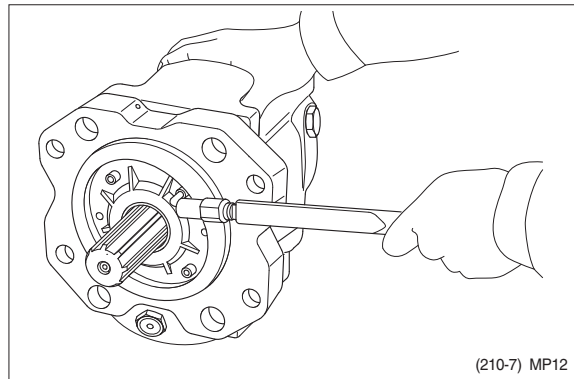

(210-7) MP12

(6) Assemble piston cylinder subassembly [cylinder block (141), piston subassembly (151, 152), set plate (153), spherical bush (156), spacer (158) and cylinder spring (157)] .

Fit spline phases of retainer and cylinder. Then, insert piston cylinder subassembly into pump casing.

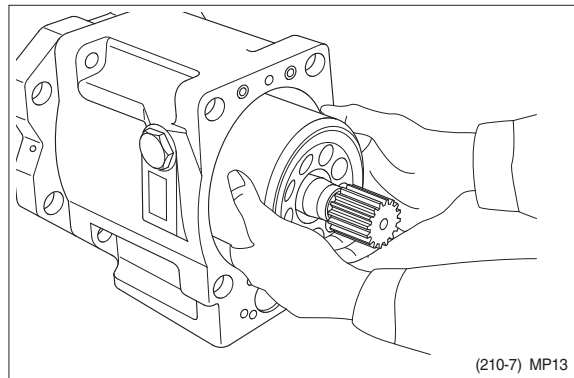

(210-7) MP13

- (7) Fit valve plate (313) to valve block (312), entering pin into pin hole.
- ※ Take care not to mistake suction / delivery directions of valve plate.

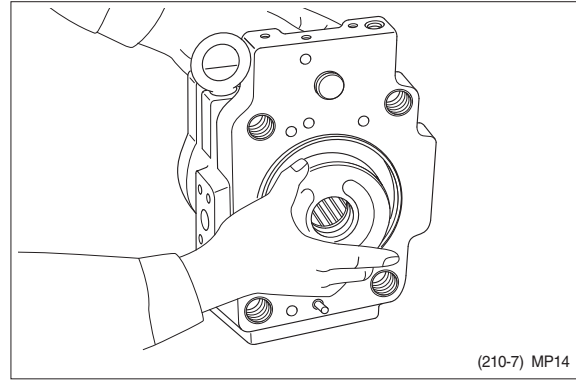

- (8) Fit valve block (312) to pump casing (271) and tighten hexagon socket head bolts (401).
- ※ At first assemble this at rear pump side, and this work will be easy.
 - ※ Take care not to mistake direction of valve block.
 - ※ Clockwise rotation (viewed from input shaft side) - Fit block with regulator up and with delivery flange left, viewed from front side.
 - ※ Counter clockwise rotation (viewed from input shaft side) - Fit block with delivery flange right, viewed from front side.

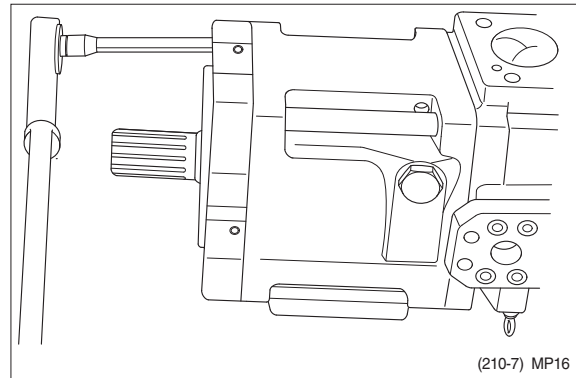

- (9) Putting feedback pin of tilting pin into feedback lever of regulator, fit regulator and tighten hexagon socket head bolts (412, 413).
- ※ Take care not to mistake regulator of front pump for that of rear pump.

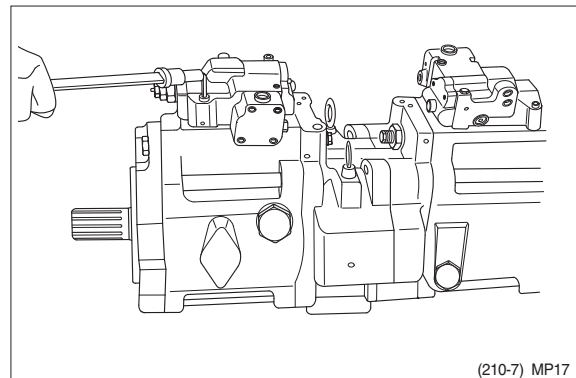

- (10) Fit drain port plug (468).
This is the end of reassembling procedures.

3. REGULATOR

1) STRUCTURE (1/2)

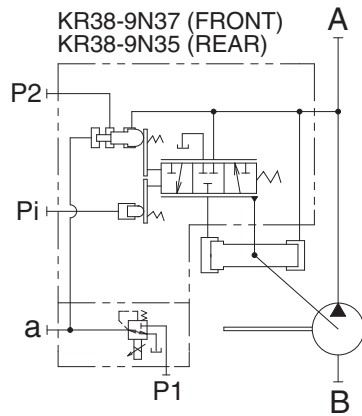
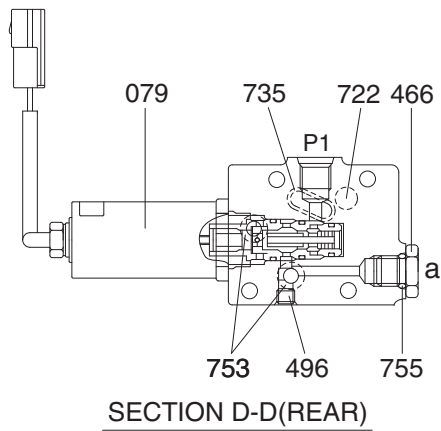
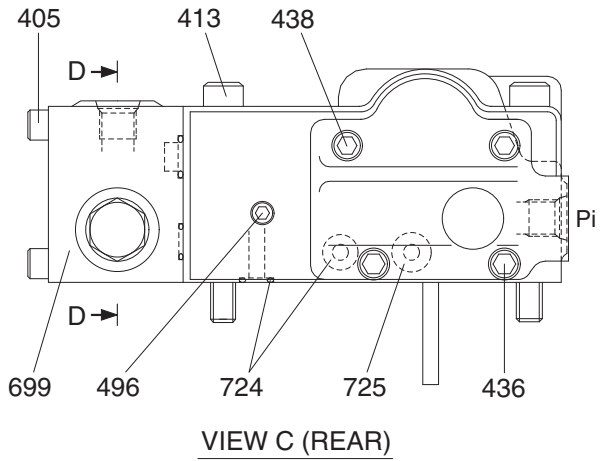
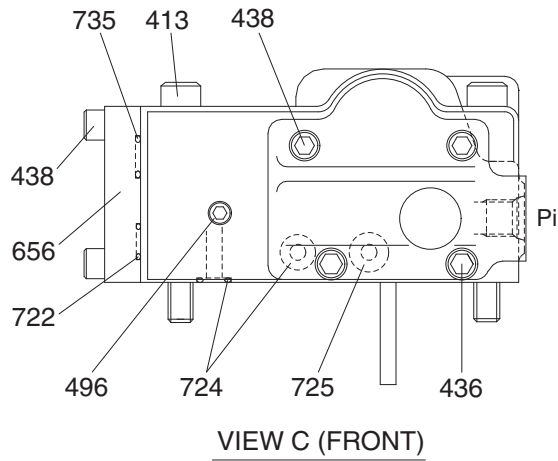
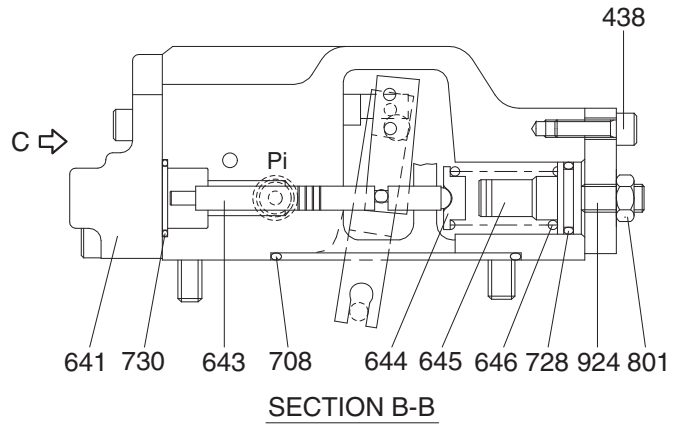
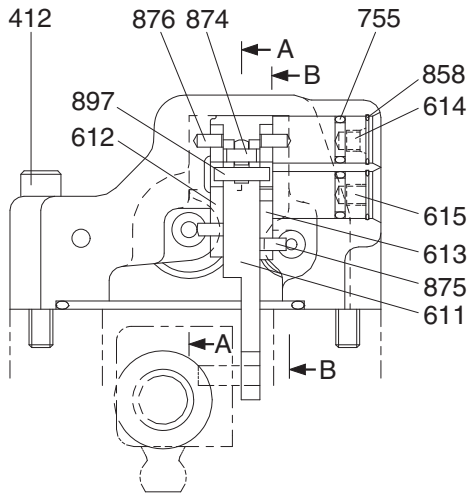

16092MP04

REGULATOR (2/2)

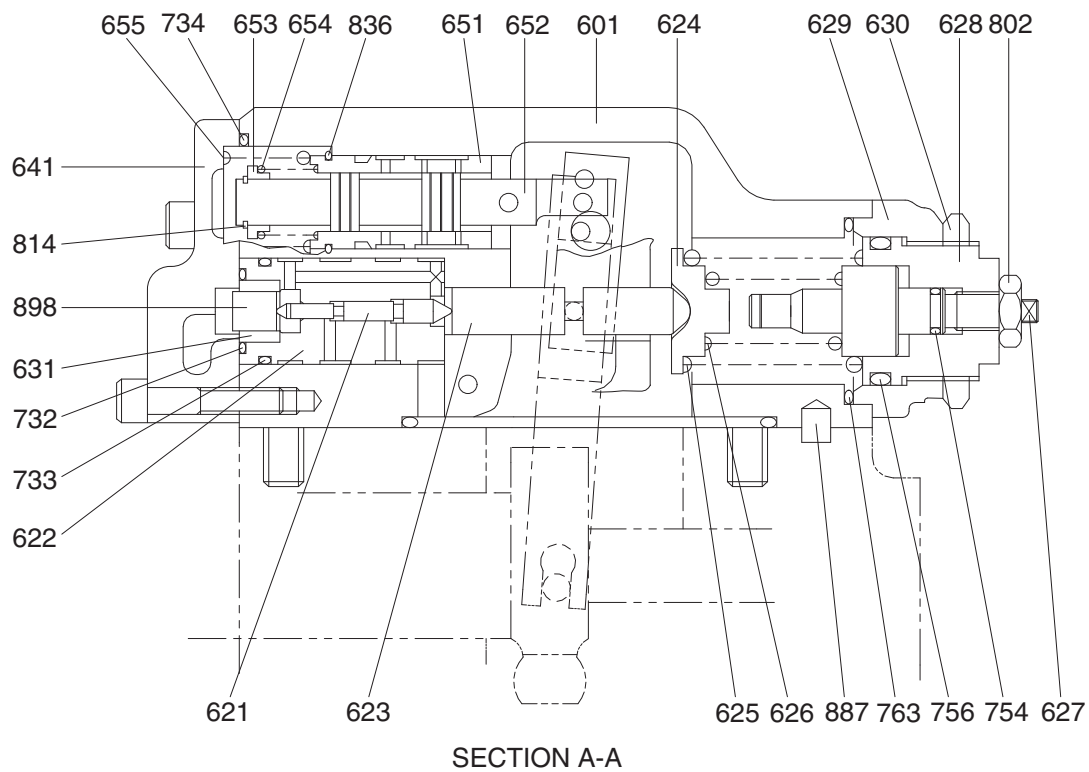



14092MP05

079	EPPR valve assembly	629	Cover (C)	733	O-ring
405	Hexagon socket screw (R)	630	Lock nut	734	O-ring
412	Hexagon socket screw	631	Sleeve, Pf	735	O-ring
413	Hexagon socket screw	641	Pilot cover	753	O-ring (R)
436	Hexagon socket screw	643	Pilot piston	754	O-ring
438	Hexagon socket screw	644	Spring seat (Q)	755	O-ring
466	Plug (R)	645	Adjust stem (Q)	756	O-ring
496	Plug	646	Pilot spring	763	O-ring
601	Casing	651	Sleeve	801	Nut
611	Feed back lever	652	Spool	802	Nut
612	Lever (1)	653	Spring seat	814	Snap ring
613	Lever (2)	654	Return spring	836	Snap ring
614	Fulcrum plug	655	Set spring	858	Snap ring
615	Adjust plug	656	Block cover (F)	874	Pin
621	Compensator piston	699	Valve casing (R)	875	Pin
622	Piston case	708	O-ring	876	Pin
623	Compensator rod	722	O-ring	887	Pin
624	Spring seat (C)	724	O-ring	897	Pin
625	Outer spring	725	O-ring	898	Pin
626	Inner spring	728	O-ring	924	Set screw
627	Adjust stem (C)	730	O-ring		
628	Adjust screw (C)	732	O-ring		

2) TOOLS AND TIGHTENING TORQUE

(1) Tools

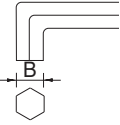
The tools necessary to disassemble/reassemble the pump are shown in the follow list.

Tool name & size		Part name			
Name	B	Hexagon socket head bolt	PT plug (PT thread)	PO plug (PF thread)	Hexagon socket head setscrew
Allen wrench 	4	M5	BP-1/16	-	M 8
	5	M6	BP-1/8	-	M10
	6	M8	BP-1/4	PO-1/4	M12, M14
Double ring spanner, socket wrench, double (single) open end spanner 	-	Hexagon head bolt	Hexagon nut	VP plug (PF thread)	
	6	M 8	M 8	-	
Adjustable angle wrench		Small size, Max 36 mm			
Screw driver		Minus type screw driver, Medium size, 2 sets			
Hammer		Plastic hammer, 1 set			
Pliers		For snap ring, TSR-160			
Steel bar		4 × 100 mm			
Torque wrench		Capable of tightening with the specified torques			
Pincers		-			
Bolt		M4, Length : 50 mm			

(2) Tightening torque

Part name	Bolt size	Torque		Wrench size	
		kgf · m	lbf · ft	in	mm
Hexagon socket head bolt (material : SCM435)	M 5	0.7	5.1	0.16	4
	M 6	1.2	8.7	0.20	5
	M 8	3.0	21.7	0.24	6
	M10	5.8	42.0	0.31	8
	M12	10.0	72.3	0.39	10
	M14	16.0	116	0.47	12
	M16	24.0	174	0.55	14
	M18	34.0	246	0.55	14
	M20	44.0	318	0.67	17
PT Plug (material : S45C) ※ Wind a seal tape 1 1/2 to 2 turns round the plug	PT1/16	0.7	5.1	0.16	4
	PT 1/8	1.05	7.59	0.20	5
	PT 1/4	1.75	12.7	0.24	6
	PT 3/8	3.5	25.3	0.31	8
	PT 1/2	5.0	36.2	0.39	10
PF Plug (material : S35C)	PF 1/4	3.0	21.7	0.24	6
	PF 1/2	10.0	72.3	0.39	10
	PF 3/4	15.0	109	0.55	14
	PF 1	19.0	137	0.67	17
	PF 1 1/4	27.0	195	0.67	17
	PF 1 1/2	28.0	203	0.67	17

3) DISASSEMBLY

Since the regulator consists of small precision finished parts, disassembly and assembly are rather complicated.

For this reason, replacement of a regulator assembly is recommended, unless there is a special reason, but in case disassembly is necessary for an unavoidable reason, read through this manual to the end before starting disassembly.

- (1) Choose a place for disassembly.
 - ※ Choose a clean place.
 - ※ Spread rubber sheet, cloth, or so on on top of work-bench to prevent parts from being damaged.
- (2) Remove dust, rust, etc. from surfaces of regulator with clean oil.

- (3) Remove hexagon socket head screw (412, 413) and remove regulator main body from pump main body.
 - ※ Take care not to lose O-ring.

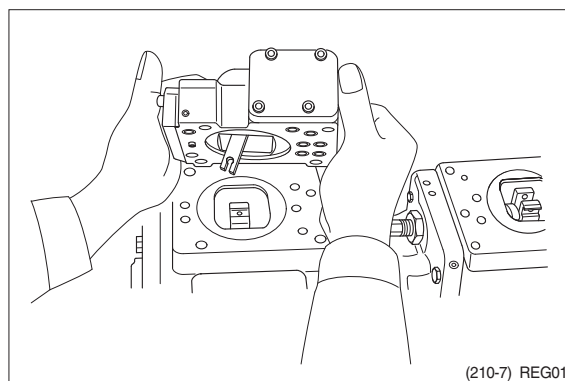

- (4) Remove hexagon socket head screw (438) and remove cover (C, 629)
 - ※ Cover (C) is fitted with adjusting screw (C, 628), adjusting ring (C, 627), lock nut (630), hexagon nut (801) and adjusting screw (924).
 - ※ Do not loosen these screws and nuts. If they are loosened, adjusted pressure-flow setting will vary.

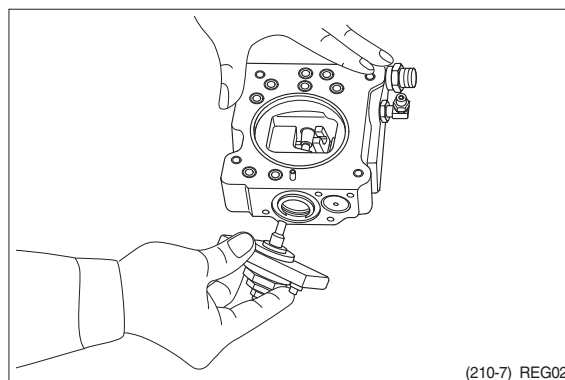

- (5) After removing cover (C, 629) subassembly, take out outer spring (625), inner spring (626) and spring seat (C, 624) from compensating section.

Then draw out adjusting ring (Q, 645), pilot spring (646) and spring seat (644) from pilot section.

- ※ Adjusting ring (Q, 645) can easily be drawn out with M4 bolt.

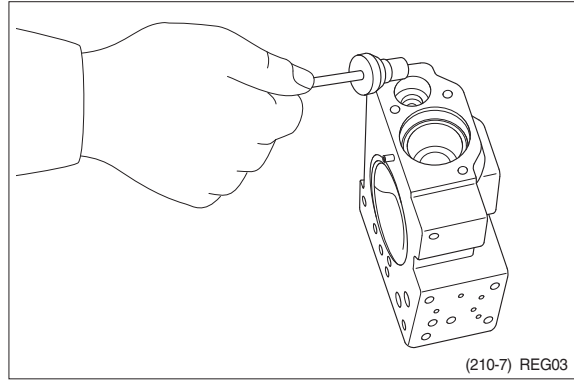

- (6) Remove hexagon socket head screws (436, 438) and remove pilot cover (641). After removing pilot cover, take out set spring (655) from pilot section.

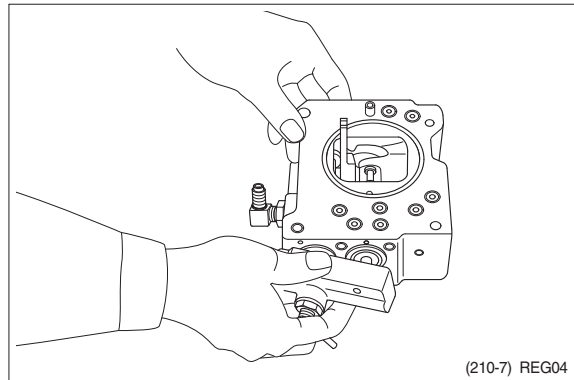

- (7) Remove snap ring (814) and take out spring seat (653), return spring (654) and sleeve (651).

- ※ Sleeve (651) is fitted with snap ring (836).
- ※ When removing snap ring (814), return spring (654) may pop out. Take care not to lose it.

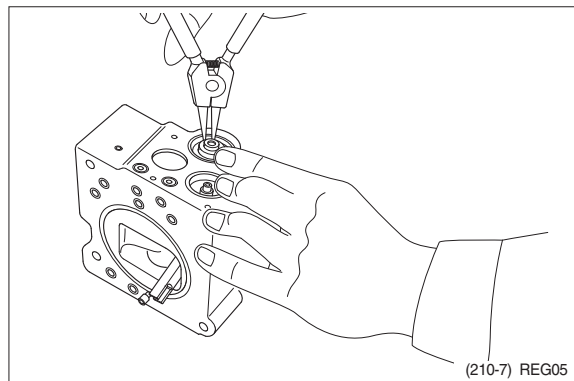

- (8) Remove locking ring (858) and take out fulcrum plug (614) and adjusting plug (615).

- ※ Fulcrum plug (614) and adjusting plug (615) can easily be taken out with M6 bolt.

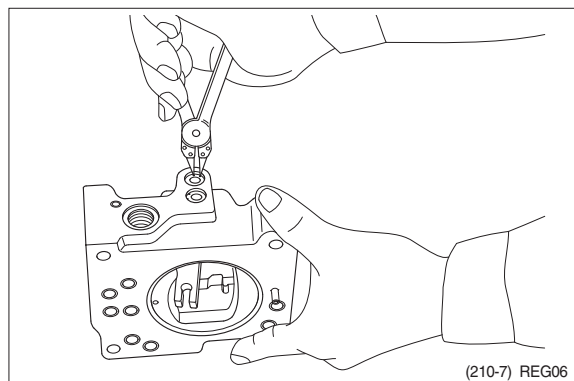

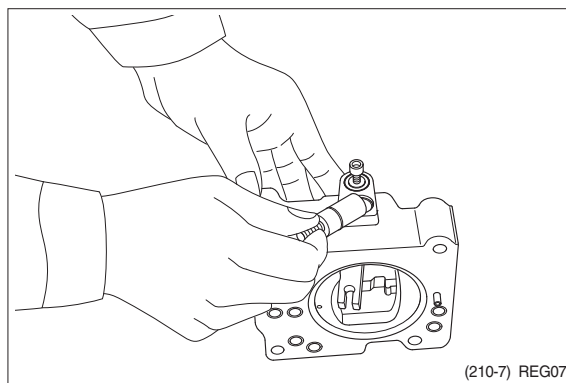

- (9) Remove lever (2, 613). Do not draw out pin (875).
※ Work will be promoted by using pincers or so on.

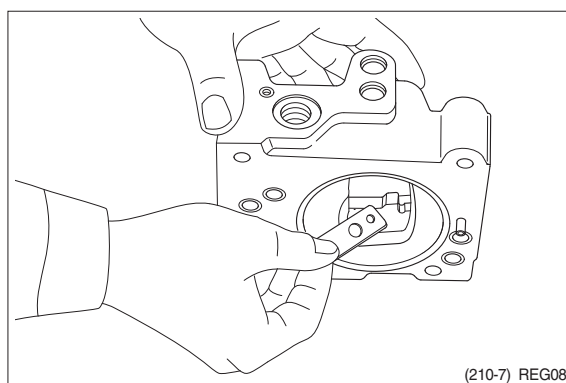

- (10) Draw out pin (874) and remove feedback lever (611).
Push out pin (874, 4 mm in dia.) from above with slender steel bar so that it may not interfere with lever (1, 612).

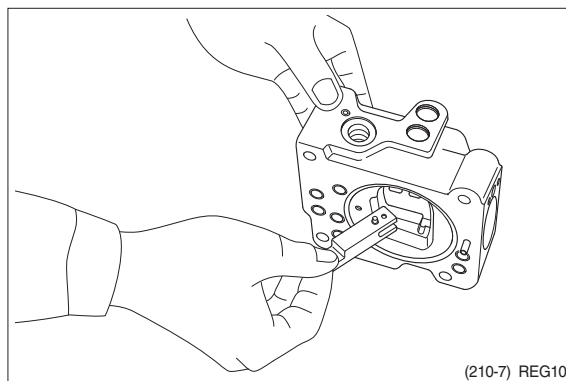
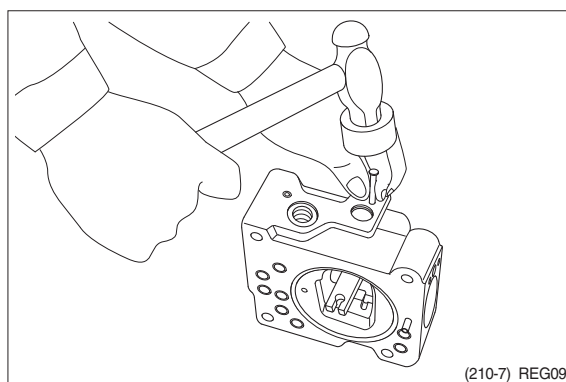

- (11) Remove lever (1, 612). Do not draw out pin (875).
 - (12) Draw out pilot piston (643) and spool (652).
 - (13) Draw out piston case (622), compensating piston (621) and compensating rod (623).
- ※ Piston case (622) can be taken out by pushing compensating rod (623) at opposite side of piston case.

This completes disassembly.

4) ASSEMBLY

(1) For assembly, reverse disassembly procedures, but pay attention to the following items.

- ① Always repair parts that were scored at disassembly.
- ② Get replacement parts ready beforehand.
Mixing of foreign matter will cause malfunction.
Therefore, wash parts well with cleaning oil, let them dry with jet air and handle them in clean place.
- ③ Always tighten bolts, plugs, etc. to their specified torques.
- ④ Do not fail to coat sliding surfaces with clean hydraulic oil before assembly.
- ⑤ Replace seals such as O-ring with new ones as a rule.

(2) Put compensating rod (623) into compensating hole of casing (601).

(3) Put pin force-fitted in lever (1, 612) into groove of compensating rod and fit lever (1) to pin force-fitted in casing.

(4) Fit spool (652) and sleeve (651) into hole in spool of casing.

- ※ Confirm that spool and sleeve slide smoothly in casing without binding.
- ※ Pay attention to orientation of spool.

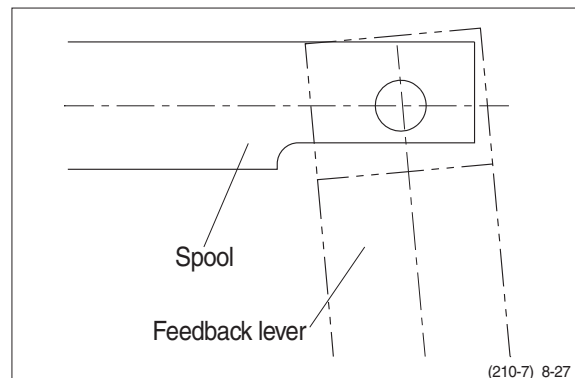

- (5) Fit feedback lever (611), matching its pin hole with pin hole in spool.
Then insert pin (874).
- ※ Insert pin in feedback lever a little to ease operation.
 - ※ Take care not to mistake direction of feedback lever.

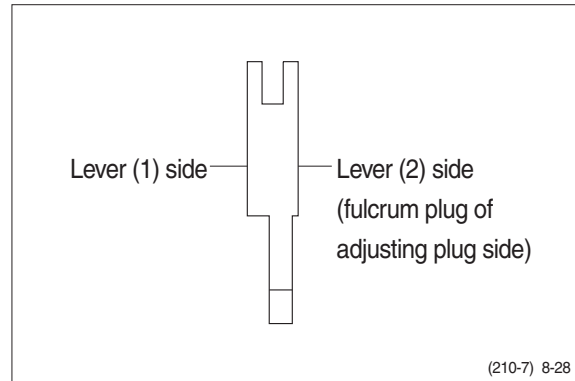

- (6) Put pilot piston (643) into pilot hole of casing.
- ※ Confirm that pilot piston slides smoothly without binding.
- (7) Put pin force-fitted in lever (2, 613) into groove of pilot piston.
Then fix lever (2).

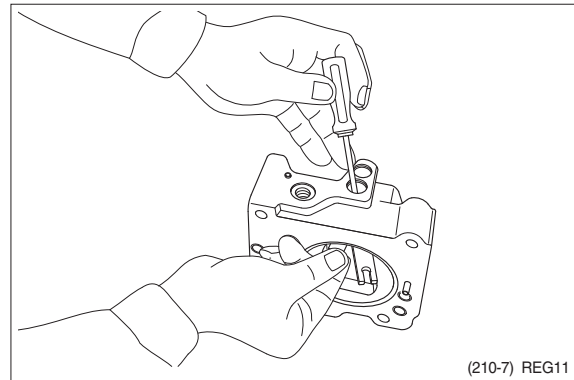

- (8) Fit fulcrum plug (614) so that pin force-fitted in fulcrum plug (614) can be put into pin hole of lever (2).
Then fix locking ring (858).
- (9) Insert adjusting plug (615) and fit locking ring.
- ※ Take care not to mistake inserting holes for fulcrum plug and adjusting plug.
- At this point in time move feedback lever to confirm that it has no large play and is free from binding.

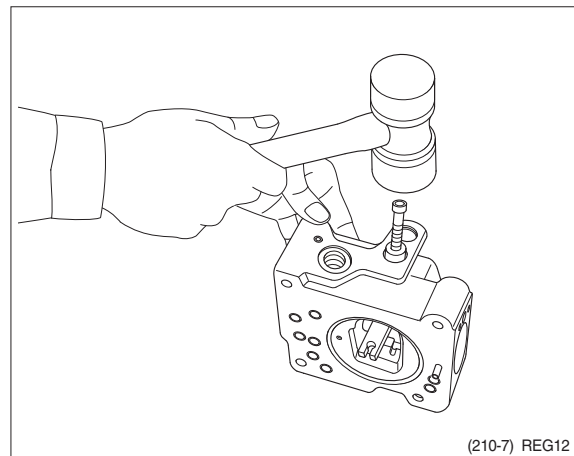

- (10) Fit return spring (654) and spring seat (653) into spool hole and attach snap ring (814).

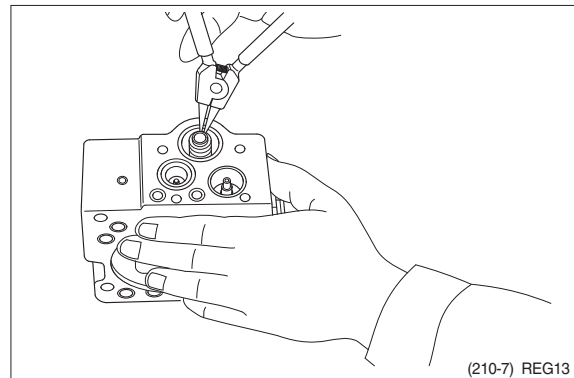

- (11) Fit set spring (655) to spool hole and put compensating piston (621) and piston case (622) into compensating hole.

Fit pilot cover (641) and tighten it with hexagonal socket head screws (436, 438).

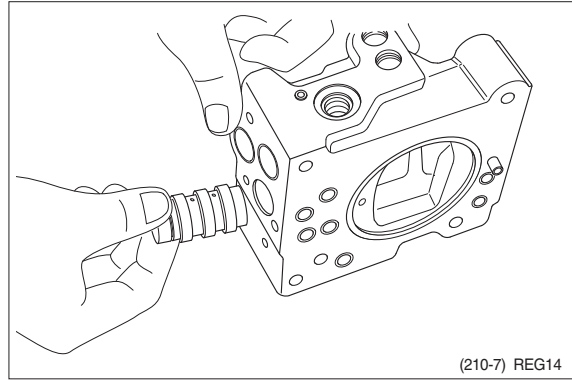

- (12) Put spring seat (644), pilot spring (646) and adjusting ring (Q, 645) into pilot hole. Then fix spring seat (624), inner spring (626) and outer spring (625) into compensating hole.

※ When fitting spring seat, take care not to mistake direction of spring seat.

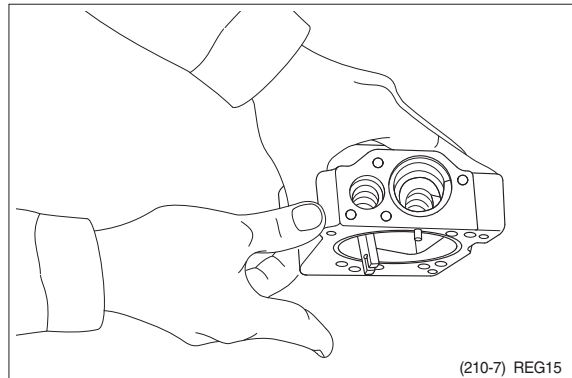

- (13) Install cover (C, 629) fitted with adjusting screws (628), adjusting ring (C, 627), lock nut (630), hexagon nut (801) and adjusting screw (924).

Then tighten them with hexagonal socket head screws (438).

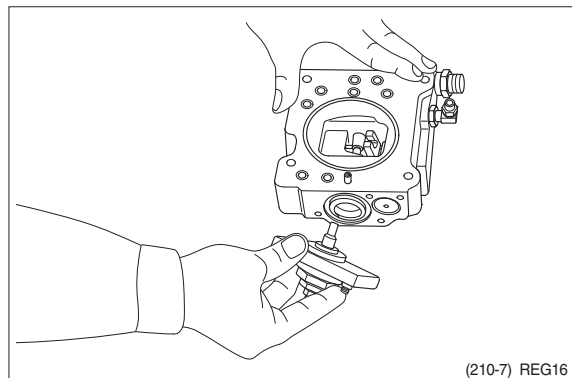

This completes assembly.

GROUP 4 MAIN CONTROL VALVE

1. REMOVAL AND INSTALL OF MOTOR

1) REMOVAL

- (1) Lower the work equipment to the ground and stop the engine.
- (2) Operate the control levers and pedals several times to release the remaining pressure in the hydraulic piping.
- (3) Loosen the breather slowly to release the pressure inside the hydraulic tank.
- ▲ **Escaping fluid under pressure can penetrate the skin causing serious injury.**
 - ※ When pipes and hoses are disconnected, the oil inside the piping will flow out, so catch it in oil pan.
- (4) Remove the wirings for the pressure sensor and so on.
- (5) Remove bolts and disconnect pipe.
- (6) Disconnect pilot line hoses.
- (7) Disconnect pilot piping.
- (8) Sling the control valve assembly and remove the control valve mounting bolt and bracket.
 - Weight : 140 kg (310 lb)
- (9) Remove the control valve assembly.
When removing the control valve assembly, check that all the piping have been disconnected.

2) INSTALL

- (1) Carry out installation in the reverse order to removal.
- (2) Bleed the air from below items.
 - ① Cylinder (boom, arm, bucket)
 - ② Swing motor
 - ③ Travel motor
 - ※ See each item removal and install.
- (3) Confirm the hydraulic oil level and recheck the hydraulic oil leak or not.

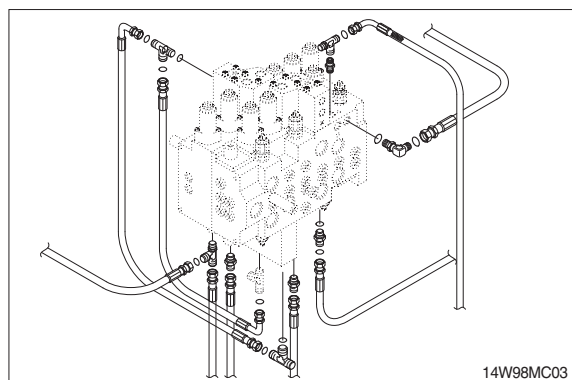
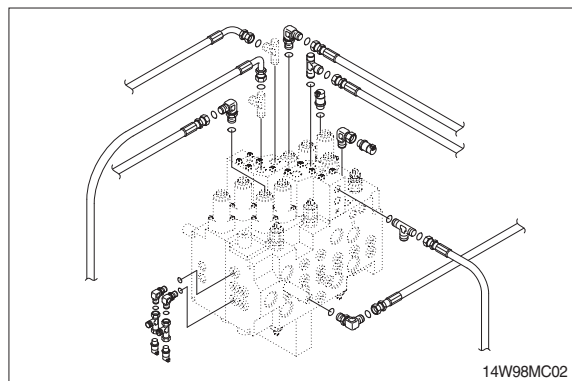
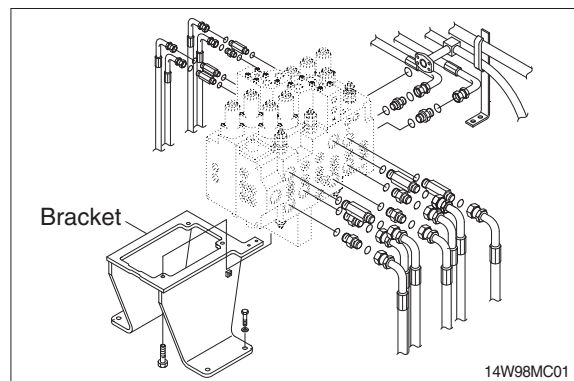

2. STRUCTURE (1/4)

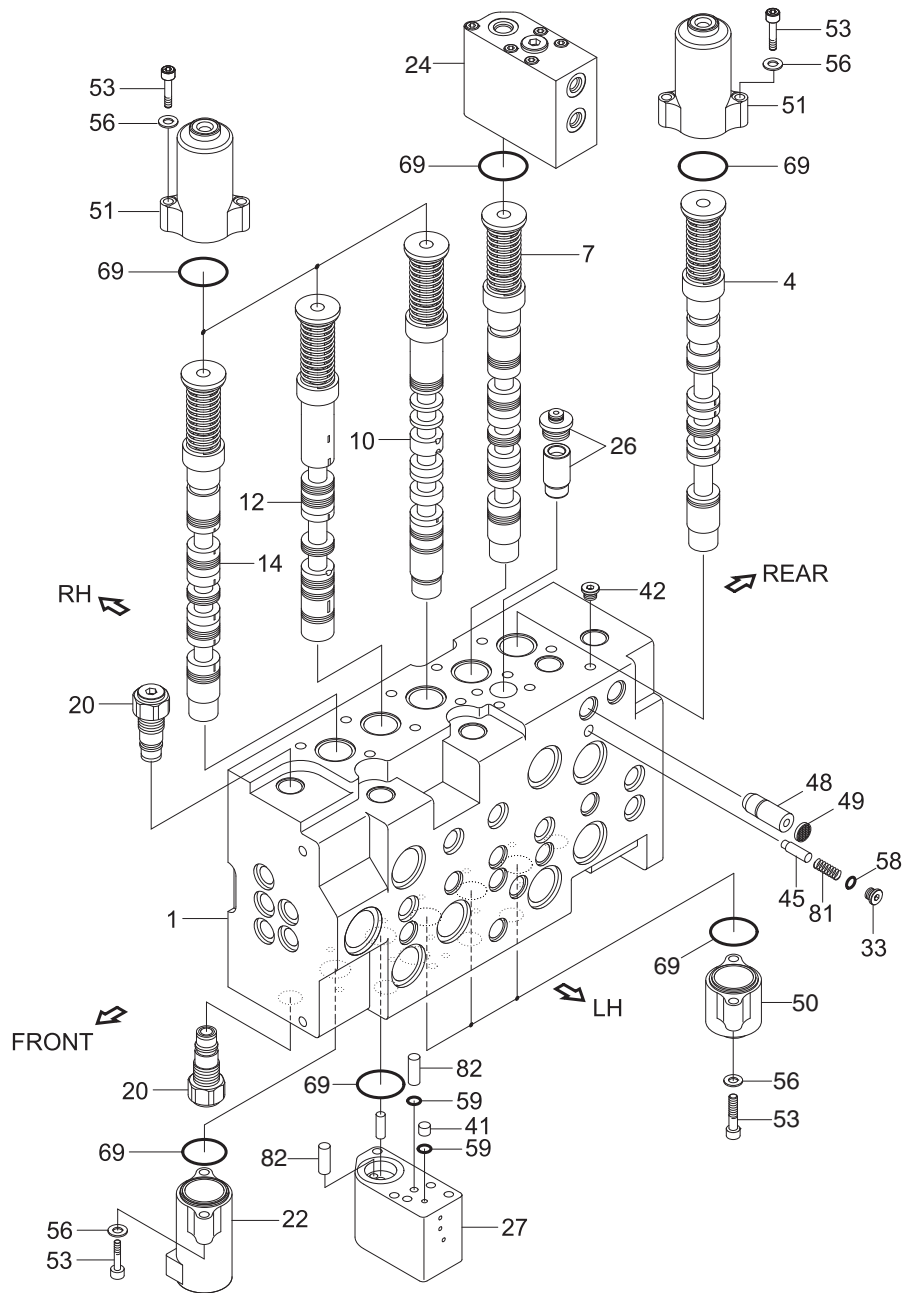

160F8MC04

- | | | | | | |
|----|------------------------|----|--------------------|----|--------------|
| 1 | Housing P1 | 26 | Lock valve kit B | 51 | Pilot B1 cap |
| 4 | Travel (LH) spool assy | 27 | Regeneration block | 53 | Socket bolt |
| 7 | Boom 1 spool assy | 33 | Plug | 56 | Plain washer |
| 10 | Arm 2 spool assy | 41 | Orifice | 58 | O-ring |
| 12 | Arm regen spool assy | 42 | Plug | 59 | O-ring |
| 14 | Bucket spool assy | 45 | Poppet | 69 | O-ring |
| 20 | Nega con relief valve | 48 | Orifice | 81 | Spring |
| 22 | Bucket stroke limiter | 49 | Coin type filter | 82 | Pin |
| 24 | Holding valve kit A1 | 50 | Pilot A cap | | |

STRUCTURE (2/4)

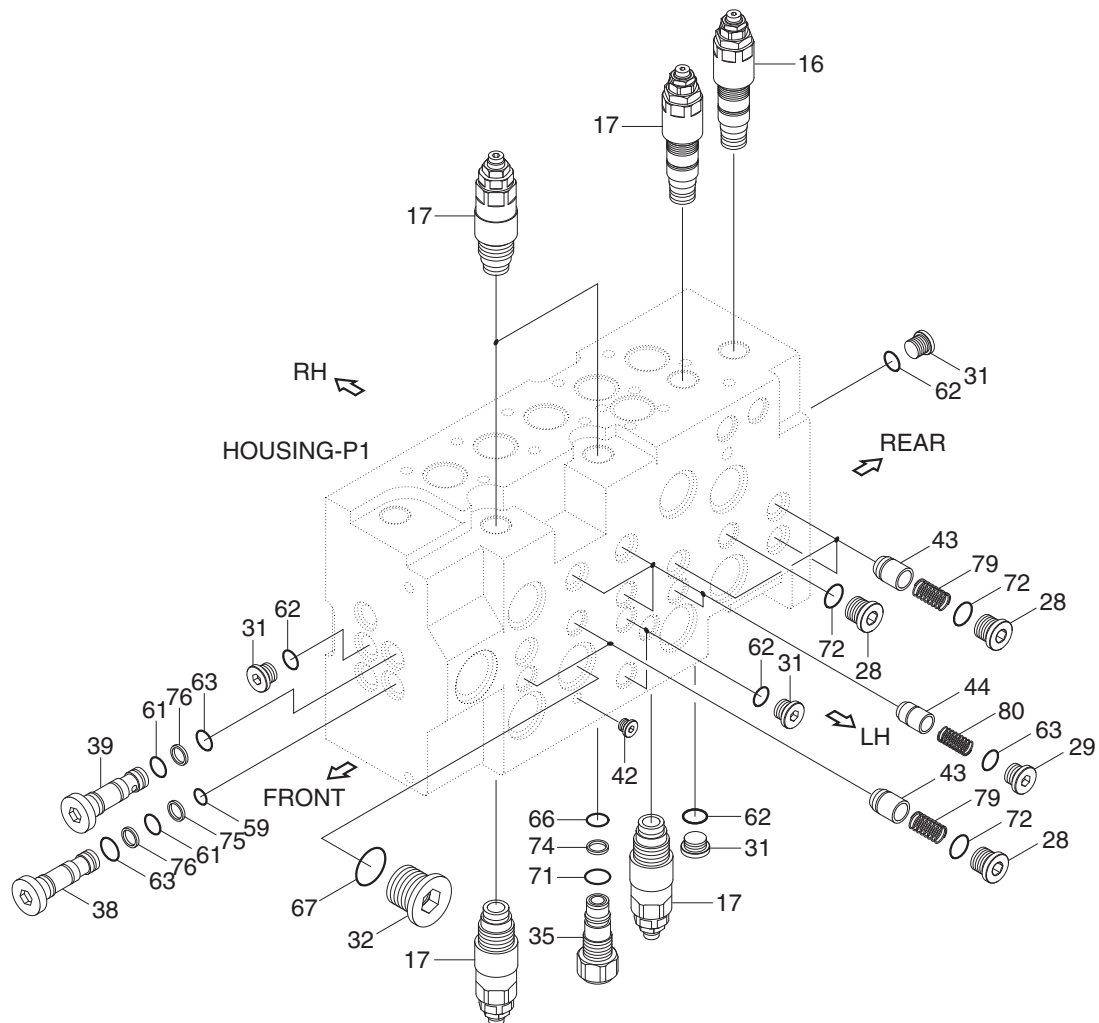

16098MC05

- 16 Main relief valve
- 17 Overload relief valve
- 28 Plug
- 29 Plug
- 31 Plug
- 32 Plug
- 35 Plug
- 38 Plug
- 39 Plug

- 42 Plug
- 43 Poppet 1
- 44 Poppet 2
- 59 O-ring
- 61 O-ring
- 62 O-ring
- 63 O-ring
- 66 O-ring
- 67 O-ring

- 71 O-ring
- 72 O-ring
- 74 Back up ring
- 75 Back up ring
- 76 Back up ring
- 79 Spring
- 80 Spring

STRUCTURE (3/4)

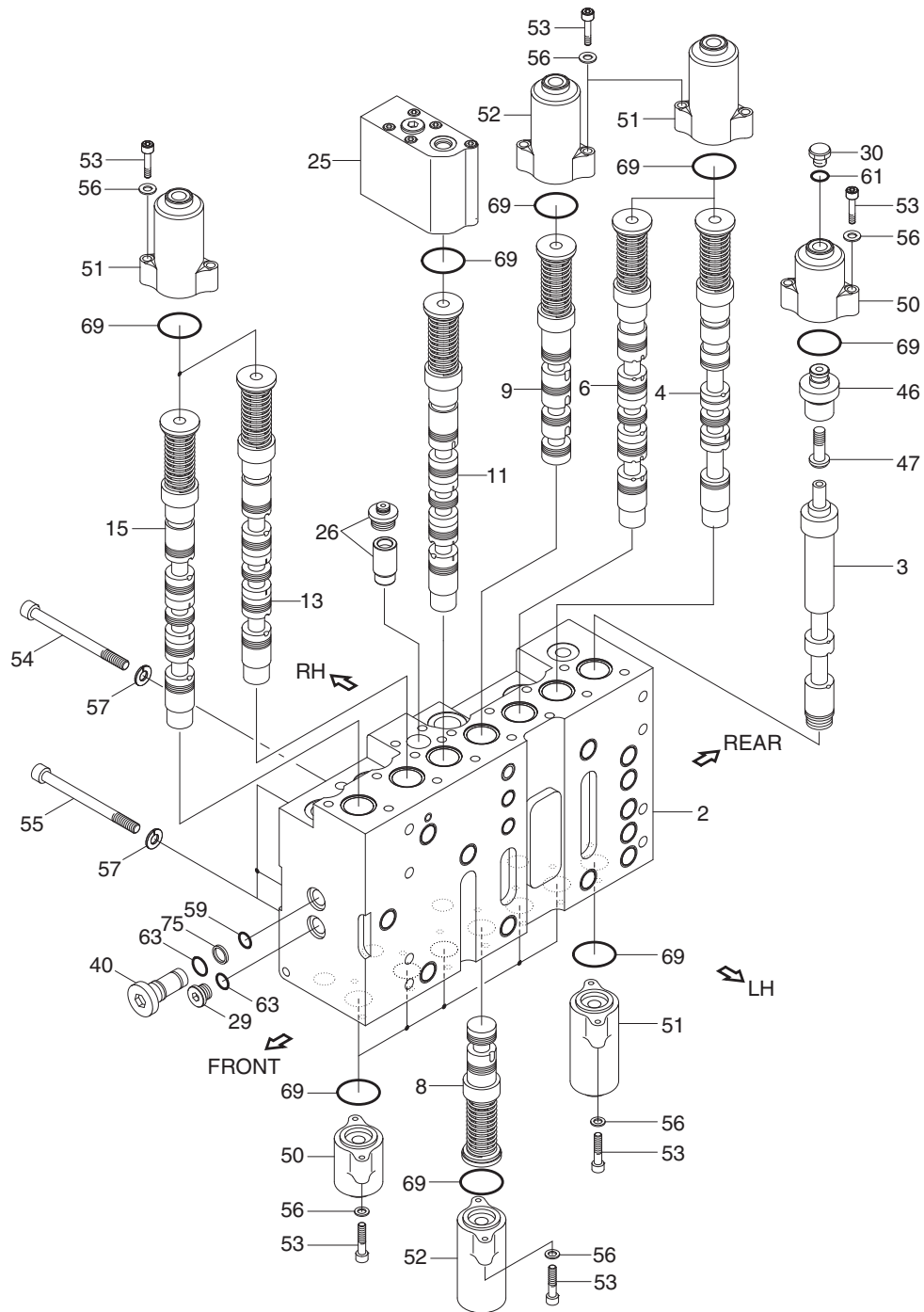

160F8MC06

- | | | | | | |
|----|----------------------------|----|------------------|----|---------------|
| 2 | Housing P2 | 26 | Lock valve kit B | 54 | Socket bolt |
| 3 | Travel straight spool assy | 29 | Plug | 55 | Socket bolt |
| 4 | Travel (RH) spool assy | 30 | Plug | 56 | Plain washer |
| 6 | Swing spool assy | 40 | Plug | 57 | Spring washer |
| 8 | Swing priority spool assy | 46 | Sleeve | 59 | O-ring |
| 9 | Boom 2 spool assy | 47 | Piston | 61 | O-ring |
| 11 | Arm 1 spool assy | 50 | Pilot A cap | 63 | O-ring |
| 13 | Option B spool assy | 51 | Pilot B1 cap | 69 | O-ring |
| 15 | Option C spool assy | 52 | Pilot B2 cap | 75 | Back up ring |
| 25 | Holding valve kit A2 | 53 | Socket bolt | | |

STRUCTURE (4/4)

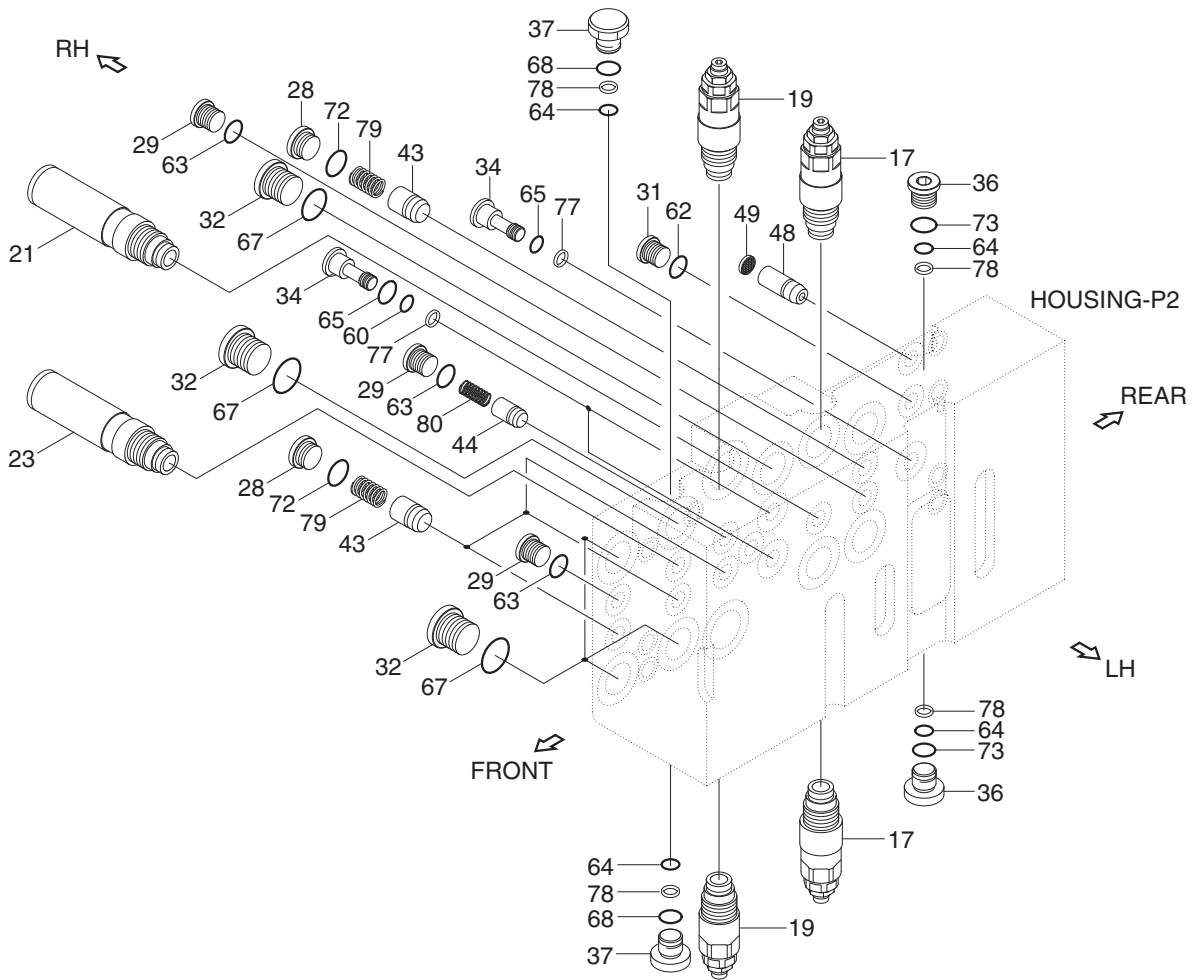

160F8MC07

- | | | | | | |
|----|-----------------------|----|------------------|----|--------------|
| 17 | Overload relief valve | 37 | Plug | 67 | O-ring |
| 19 | Overload relief valve | 43 | Poppet 1 | 68 | O-ring |
| 21 | Swing logic valve | 44 | Poppet 2 | 72 | O-ring |
| 23 | ON/OFF valve-option | 48 | Orifice | 73 | O-ring |
| 28 | Plug | 49 | Coin type filter | 77 | Back up ring |
| 29 | Plug | 60 | O-ring | 78 | Back up ring |
| 31 | Plug | 62 | O-ring | 79 | Spring |
| 32 | Plug | 63 | O-ring | 80 | Spring |
| 34 | Plug | 64 | O-ring | | |
| 36 | Plug | 65 | O-ring | | |

3. DISASSEMBLY AND ASSEMBLY

1) GENERAL PRECAUTIONS

- (1) All hydraulic components are manufactured to a high precision. Consequently, before disassembling and assembling them, it is essential to select an especially clean place.
- (2) In handling a control valve, pay full attention to prevent dust, sand, etc. from entering into it.
- (3) When a control valve is to be removed from the machine, apply caps and masking seals to all ports. Before disassembling the valve, recheck that these caps and masking seals are fitted completely, and then clean the outside of the assembly. Use a proper bench for working. Spread paper or a rubber mat on the bench, and disassemble the valve on it.
- (4) Support the body section carefully when carrying or transferring the control valve. Do not lift by the exposed spool, end cover section etc.
- (5) After disassembling and assembling of the component it is desired to carry out various tests (for the relief characteristics, leakage, flow resistance, etc.), but hydraulic test equipment is necessary for these tests. Therefore, even when its disassembling can be carried out technically, do not disassemble such components that cannot be tested, adjusted, and so on. Additionally one should always prepare clean cleaning oil, hydraulic oil, grease, etc. beforehand.

2) TOOLS

Before disassembling the control valve, prepare the following tools beforehand.

Name of tool	Quantity	Size (mm)
Vice mounted on bench (soft jaws)	1 unit	
Hexagon wrench	Each 1 piece	5, 6, 10, 12 and 14
Socket wrench	Each 1 piece	27 and 32
Spanner	Each 1 piece	32 (main relief valve, overload relief valve, negative relief valve) 26 (holding valve)

3) DISASSEMBLY

(1) Disassembly of spools without holding valve (travel right, travel left)

- ① Loosen hexagon socket head bolts with washer.
(hexagon wrench : 5 mm)
 - ② Remove the pilot cover.
- ※ Pay attention not to lose the O-ring under the pilot cover.
- ③ Remove the spool assembly from the body by hand slightly.
- ※ When extracting each spool from its body, pay attention not to damage the body.
 - ※ When extracting each spool assembly, it must be extracted from spring side only.
 - ※ When any abnormal parts are found, replace it with completely new spool assembly.
 - ※ When disassembled, tag the components for identification so that they can be reassembled correctly.

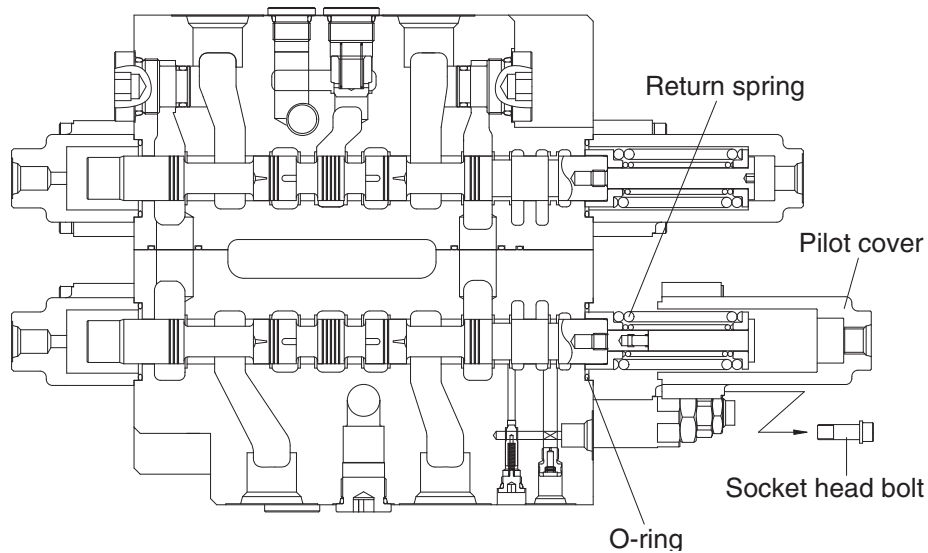

14098MC10

(2) Disassembly of spools with holding valve (boom 1, arm 1 spool)

- ① Loosen hexagon socket head bolts with washer.
(hexagon wrench : 5 mm)
- ② Remove the pilot cover with internal parts.
 - ※ Pay attention not to lose the O-ring and the poppet under the pilot cover.
 - ※ Pay attention not to damage the "piston A" under pilot cover.
- ③ Remove the spool assembly from the body by hand slightly.
 - ※ When extracting each spool from its body, pay attention not to damage the body.
 - ※ When extracting each spool assembly, it must be extracted from spring side only.
 - ※ When any abnormal parts are found, replace it with completely new spool assembly.
 - ※ When disassembled, tag the components for identification so that they can be reassembled correctly.

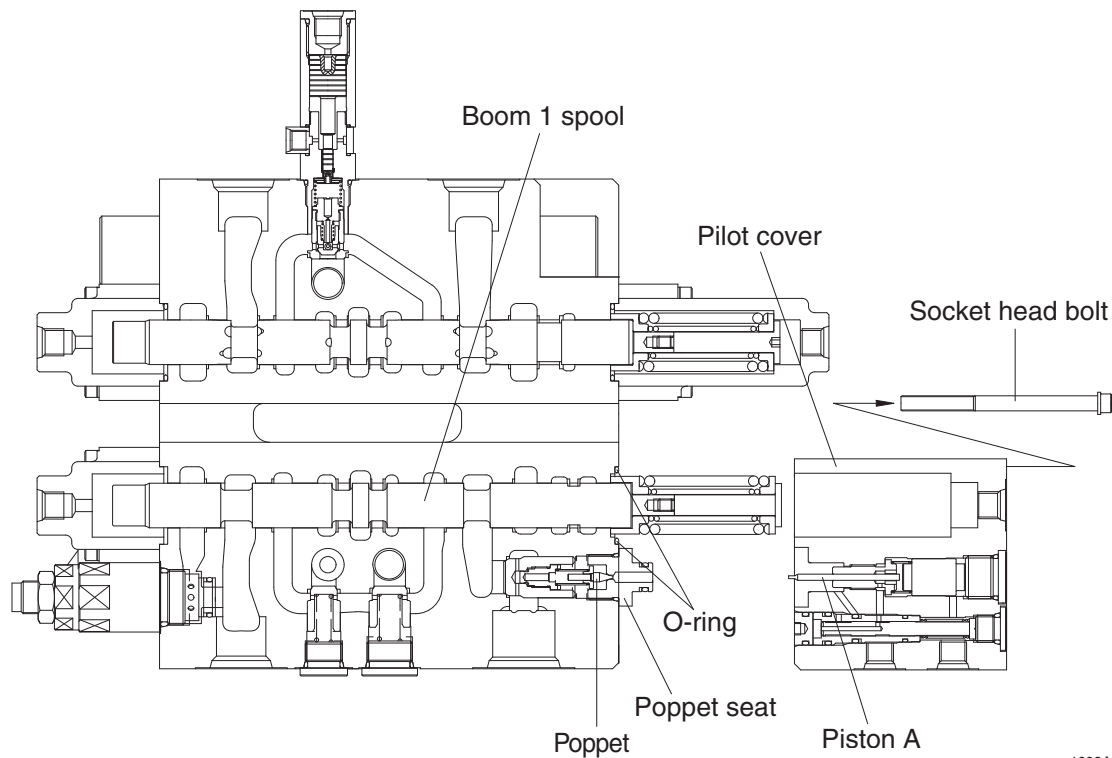

1609A8MC11

(3) Disassembly of the holding valve

- ① Remove the pilot cover with the holding valve as described on previous page.
 - ※ Do not disassemble internal parts of the pilot cover.
- ② Loosen the poppet seat and remove the poppet, spring seat, spring and check.
(spanner : 26 mm)
 - ※ Pay attention not to lose the poppet.
 - ※ Do not disassemble internal parts of the check.

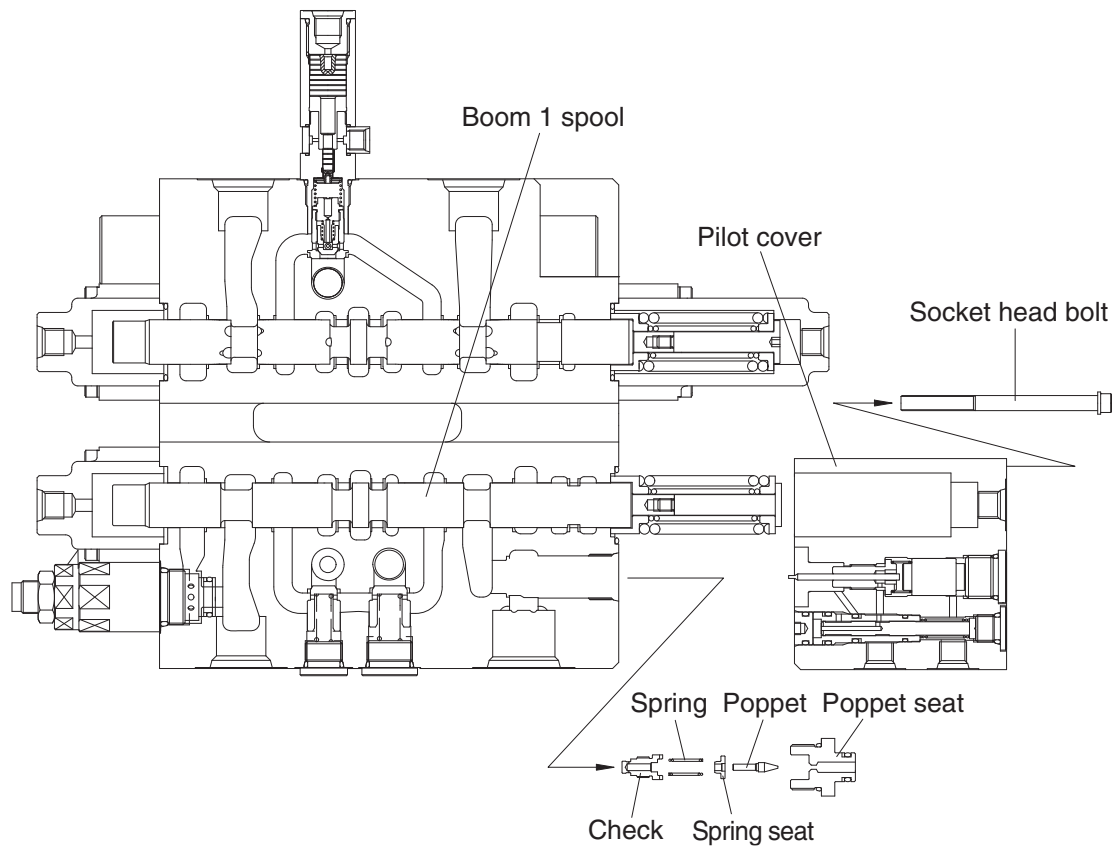

1609A8MC12

(4) Disassembly of the load check valve and the negative relief valve

- ① The load check valve
 - a. Fix the body to suitable work bench.
 - ※ Pay attention not to damage the body.
 - b. Loosen the plug (hexagon wrench : 10 mm).
 - c. Remove the spring and the load check valve with pincers or magnet.
- ② The negative relief valve
 - a. Loosen the socket (spanner : 32 mm).
 - b. Remove the spring, spring holder, piston and negative control poppet.

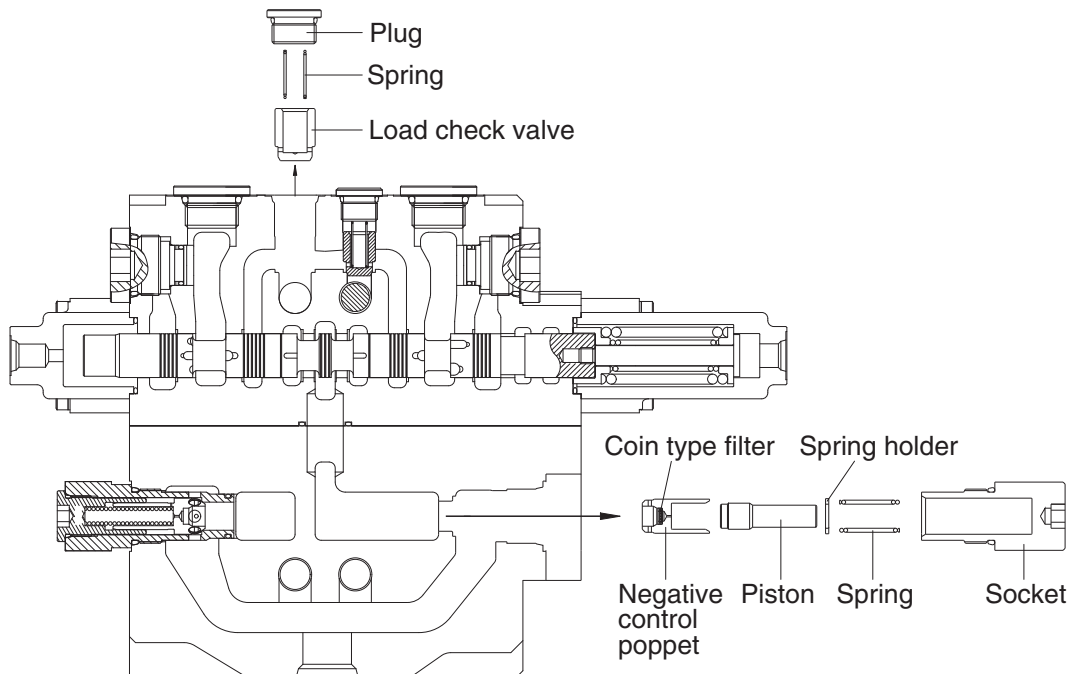

14W98MC13

(5) Disassembly of the main and overload relief valve

- ① Fix the body to suitable work bench.
 - ② Remove the main relief valve.
(spanner : 32 mm)
 - ③ Remove the overload relief valve.
(spanner : 32 mm)
- ※ When disassembled, tag the relief valve for identification so that they can be reassembled correctly.
 - ※ Pay attention not to damage seat face.
 - ※ When any abnormal parts are found, replace it with completely new relief valve assembly.

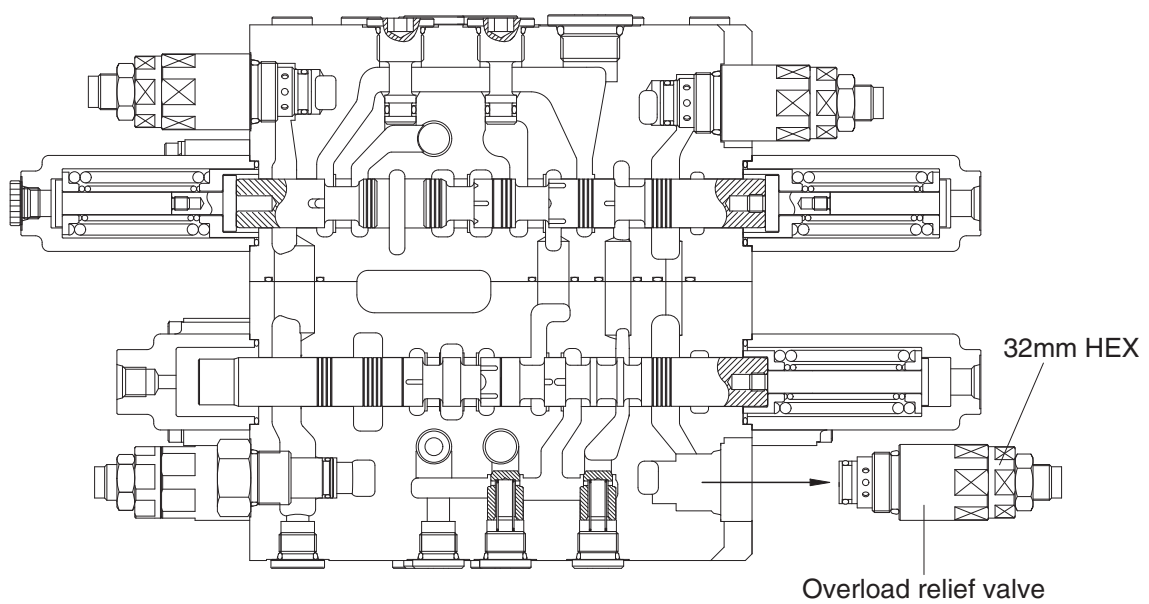
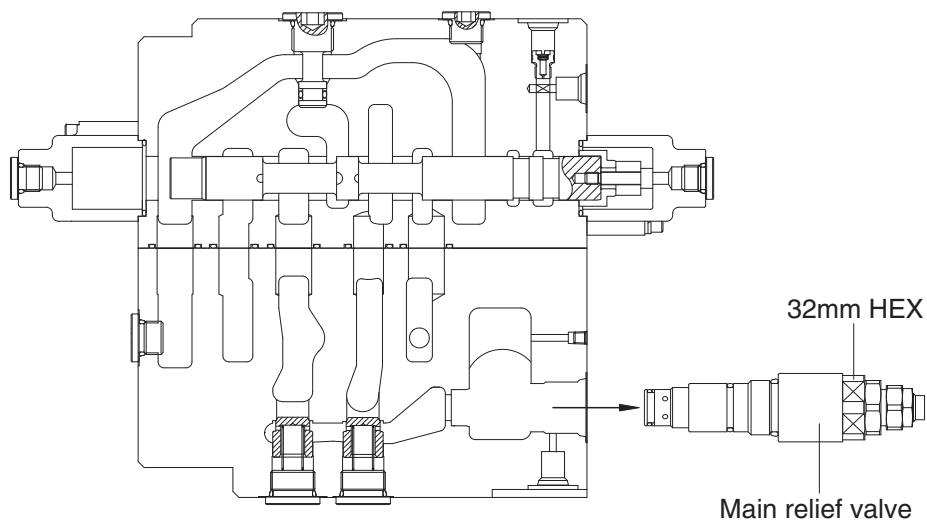

1609A8MC14

(6) Inspection after disassembly

Clean all disassembled parts with clean mineral oil fully, and dry them with compressed air. Then, place them on clean papers or cloths for inspection.

① Control valve

- a. Check whole surfaces of all parts for burrs, scratches, notches and other defects.
- b. Confirm that seal groove faces of body and block are smooth and free of dust, dent, rust etc.
- c. Correct dents and damages and check seat faces within the body, if any, by lapping.
※ Pay careful attention not to leave any lapping agent within the body.
- d. Confirm that all sliding and fitting parts can be moved manually and that all grooves and paths are free foreign matter.
- e. If any spring is broken or deformed, replace it with new one.
- f. When a relief valve does not function properly, repair it, following it's the prescribed disassembly and assembly procedures.
- g. Replace all seals and O-rings with new ones.

② Relief valve

- a. Confirm that all seat faces at ends of all poppets and seats are free of defects and show uniform and consistent contact faces.
- b. Confirm manually that main poppet and seat can slide lightly and smoothly.
- c. Confirm that outside face of main poppet and inside face of seat are free from scratches and so on.
- d. Confirm that springs are free from breakage, deformation, and wear.
- e. Confirm that orifices of main poppet and seat section are not clogged with foreign matter.
- f. Replace all O-rings with new ones.
- g. When any light damage is found in above inspections, correct it by lapping.
- h. When any abnormal part is found, replace it with a completely new relief valve assembly.

4) ASSEMBLY

(1) General precaution

- ① In this assembly section, explanation only is shown.
For further understanding, please refer to the figures shown in the previous structure & disassembly section.
- ② Pay close attention to keeping all seals free from handling damage and inspect carefully for damage before using them.
- ③ Apply clean grease or hydraulic oil to the seal so as to ensure it is fully lubricated before assembly.
Do not stretch seals so much as to deform them permanently.
- ④ In fitting O-rings, pay close attention not to roll them into their final position in addition, a twisted
- ⑤ O-ring cannot easily untwist itself naturally and could thereby cause inadequate sealing and thereby both internal and external oil leakage.
- ⑥ Tighten fitting bolts for all sections with a torque wrench adjusted to the respective tightening torque.
- ⑦ Do not reuse removed O-rings and seals.

(2) Load check valve

- ① Assemble the load check valve and spring.
- ② Put O-rings on to plug.
- ③ Tighten plug to the specified torque.
 - Hexagon wrench : 10 mm
 - Tightening torque : 6~7 kgf · m (43.4~50.6 lbf · ft)

(3) Negative control relief valve

- ① Assemble the nega-con poppet, piston, spring holder and spring together into body.
- ② Put O-ring on to plug and tighten the latter to its specified torque.
 - Hexagon wrench : 12 mm
 - Tightening torque : 8~9 kgf · m (57.8~65.1 lbf · ft)

(4) Main relief, overload relief valves

Install main relief valve, overload relief valve into the body and tighten to the specified torque.

Component	Tools	Tightening torque	
		kgf · m	lbf · ft
Main relief valve	Spanner 32 mm	8~9	57.8~65.1
Overload relief valve	Spanner 32 mm	8~9	57.8~65.1

(5) Main spools

- ① Carefully insert the previously assembled spool assemblies into their respective bores within of body.
- ※ Fit spool assemblies into body carefully and slowly. Do not under any circumstances push them forcibly in.

(6) Pilot covers

- ① Fit spool covers to the non-spring assembly end of the spool, and tighten the hexagonal socket head bolts to the specified torque.
 - Hexagon wrench : 5 mm
 - Tightening torque : 1.0~1.1 kgf · m (7.2~7.9 lbf · ft)
- ※ Confirm that O-rings have been fitted.
- ② Fit spring covers to the spring end for the spools, and tighten hexagon socket head bolts to the specified torque.
 - Hexagon wrench : 5 mm
 - Tightening torque : 1.0~1.1 kgf·m (7.2~7.9 lbf·ft)
- ※ Confirm that O-rings have been fitted.

(7) Holding valves

- ① Assemble the check, spring seat and poppet together into body.
- ② Tighten the poppet seat to the specified torque.
 - Spanner : 26 mm
 - Tightening torque : 6~7 kgf · m (43.4~50.6 lbf · ft)
- ③ Fit the "piston A" under pilot cover with internal parts into hole on the poppet seat.
- ④ Tighten hexagon socket head bolt to specified torque.
 - Hexagon wrench : 5 mm
 - Tightening torque : 1.0~1.1 kgf · m (7.2~7.9 lbf · ft)

GROUP 5 SWING DEVICE (TYPE 1)

1. REMOVAL AND INSTALL OF MOTOR

1) REMOVAL

- (1) Lower the work equipment to the ground and stop the engine.
- (2) Operate the control levers and pedals several times to release the remaining pressure in the hydraulic piping.
- (3) Loosen the breather slowly to release the pressure inside the hydraulic tank.

▲ Escaping fluid under pressure can penetrate the skin causing serious injury.

※ When pipes and hoses are disconnected, the oil inside the piping will flow out, so catch it in oil pan.

- (4) Disconnect hose assembly (2).
- (5) Disconnect pilot line hoses (3, 4, 5, 6, 7, 8).
- (6) Sling the swing motor assembly (1) and remove the swing motor mounting socket bolts (9).

· Motor device weight : 61 kg (135 lb)

- (7) Remove the swing motor assembly.
※ When removing the swing motor assembly, check that all the piping have been disconnected.

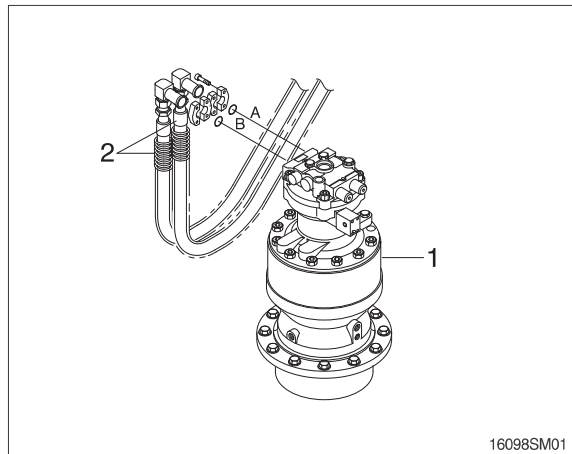

2) INSTALL

- (1) Carry out installation in the reverse order to removal.
- (2) Bleed the air from the swing motor.
 - ① Remove the air vent plug.
 - ② Pour in hydraulic oil until it overflows from the port.
 - ③ Tighten plug lightly.
 - ④ Start the engine, run at low idling and check oil come out from plug.
 - ⑤ Tighten plug fully.
- (3) Confirm the hydraulic oil level and check the hydraulic oil leak or not.

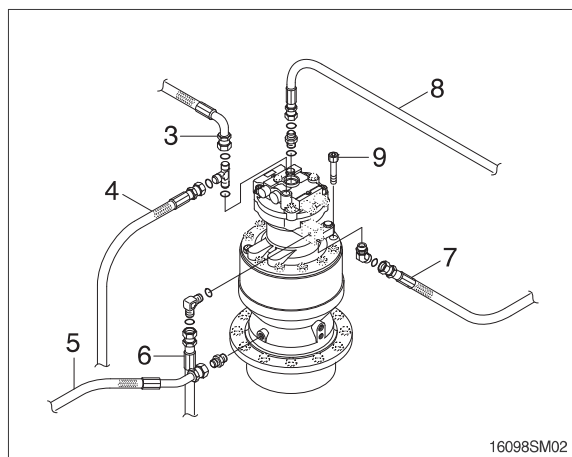

2. DISASSEMBLY AND ASSEMBLY OF SWING MOTOR

1) STRUCTURE

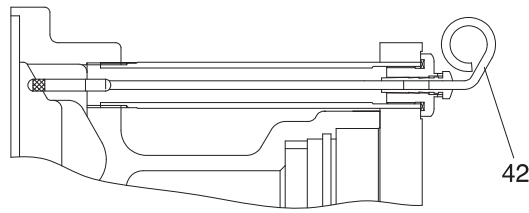

DETAIL K

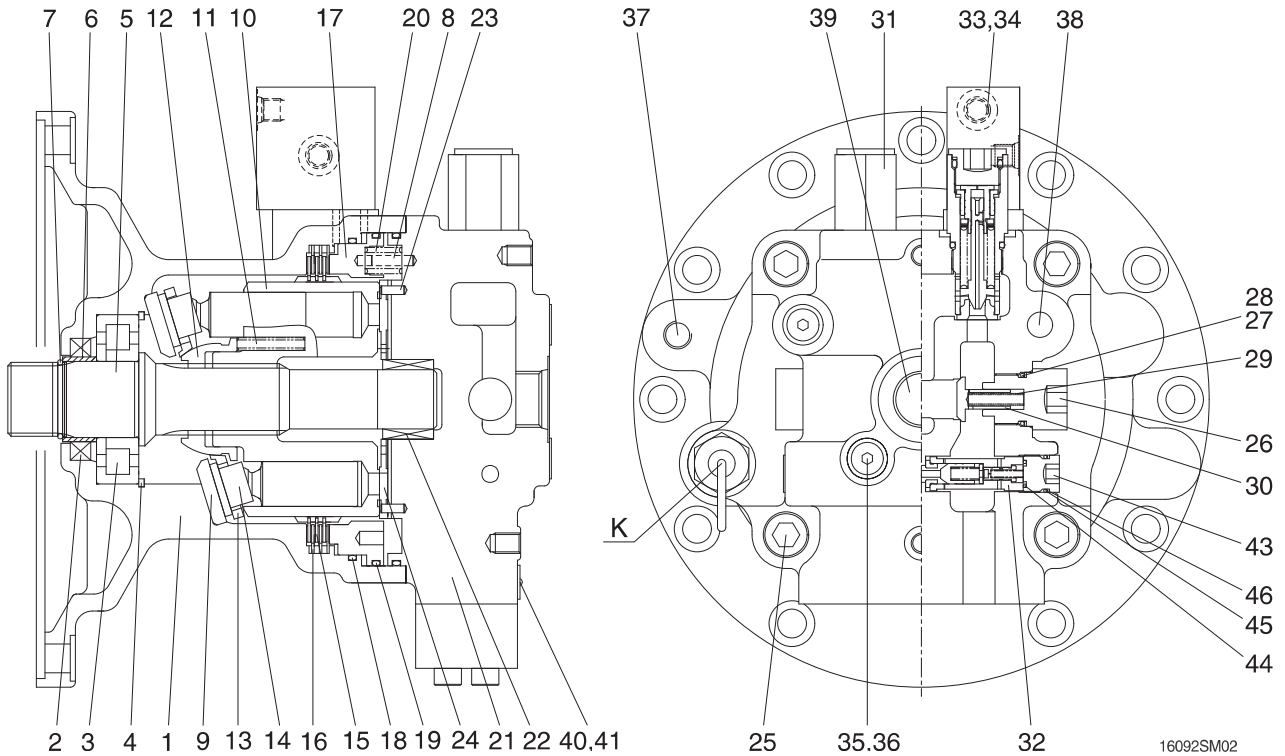

- | | | | | | |
|----|----------------|----|----------------------|----|------------------|
| 1 | Body | 17 | Brake piston | 33 | Time delay valve |
| 2 | Oil seal | 18 | O-ring | 34 | Wrench bolt |
| 3 | Roller bearing | 19 | O-ring | 35 | Plug |
| 4 | Snap ring | 20 | Brake spring | 36 | O-ring |
| 5 | Shaft | 21 | Rear cover | 37 | Plug |
| 6 | Bushing | 22 | Needle bearing | 38 | Plug |
| 7 | Stop ring | 23 | Pin | 39 | Plug |
| 8 | Pin | 24 | Valve plate | 40 | Name plate |
| 9 | Shoe plate | 25 | Wrench bolt | 41 | Rivet |
| 10 | Cylinder block | 26 | Plug | 42 | Level gauge |
| 11 | Spring | 27 | Back up ring | 43 | Plug |
| 12 | Ball guide | 28 | O-ring | 44 | O-ring |
| 13 | Set plate | 29 | Spring | 45 | O-ring |
| 14 | Piston assy | 30 | Check | 46 | Back up ring |
| 15 | Friction plate | 31 | Relief valve | | |
| 16 | Separate plate | 32 | Anti-inversion valve | | |

16092SM02

2) DISASSEMBLING

(1) Disassemble the sub of a TURNING AXIS

- ① Unloosing wrench bolt and disassemble time delay valve assy (33) from rear cover (21)



14078SM201/201A

- ② Disassemble level gauge (42) from body (1).



14078SM202/202A

- ③ Hang rear cover (21) on hoist, unloose wrench bolt (25) and disassemble from body (1).



14078SM203/203A

- ④ Using a jig, disassemble brake piston (17) from body (1).

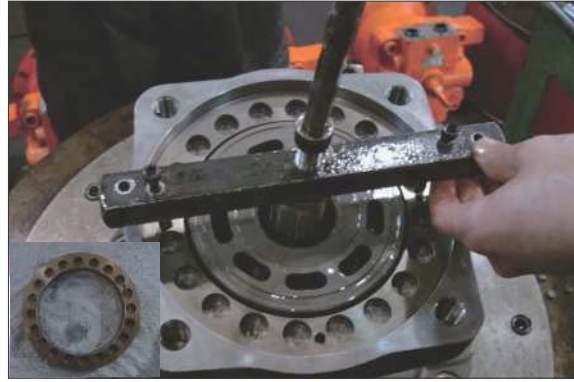

14078SM204/204A

- ⑤ Disassemble respectively cylinder block assy, friction plate (15), separate plate (16) from body (1).

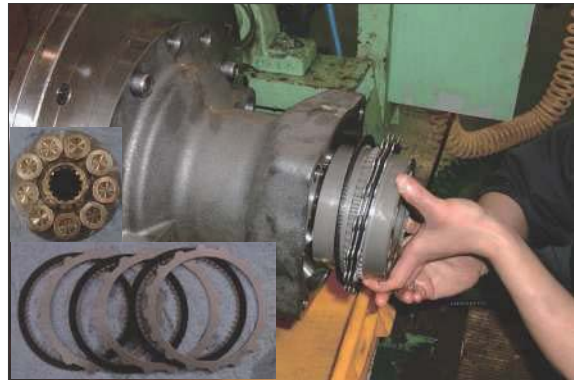

14078SM205/205A/B

(2) Disassemble cylinder block assy sub

- ① Disassemble piston assy (14), set plate (13) from cylinder block assy.



14078SM206/205B

- ② Disassemble ball guide (12) from cylinder block (10).



14078SM207/207A

- ③ Disassemble spring (11) from cylinder block (10).

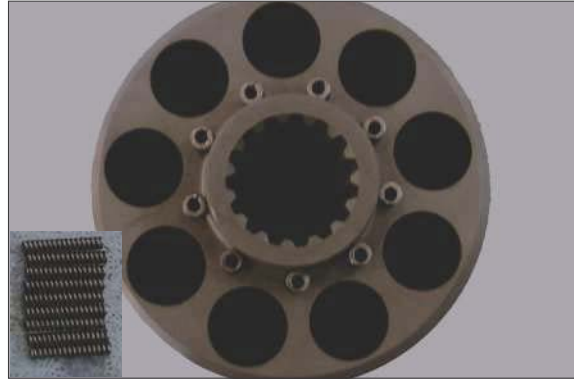

14078SM208/208A

- ④ Disassemble shoe plate (9) from body (1).



14078SM209/209A

- ⑤ Using a plier jig, disassemble snap ring (4) from shaft (5).

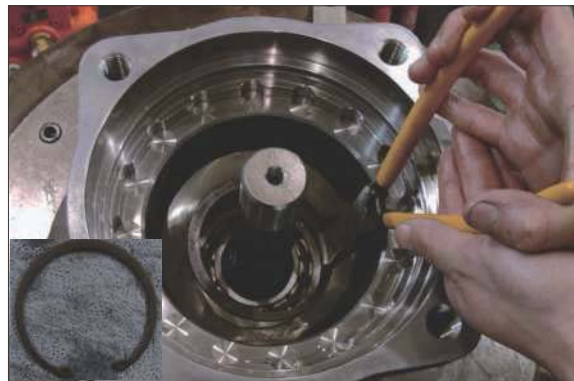

14078SM210/210A

- ⑥ Disassemble shaft assy from body (1).

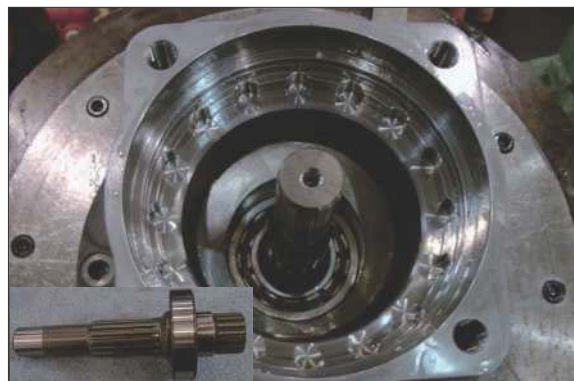

14078SM211/211A

(3) Disassemble rear cover assy sub

- ① Disassemble pin (8, 23), valve plate (24) from rear cover (21).

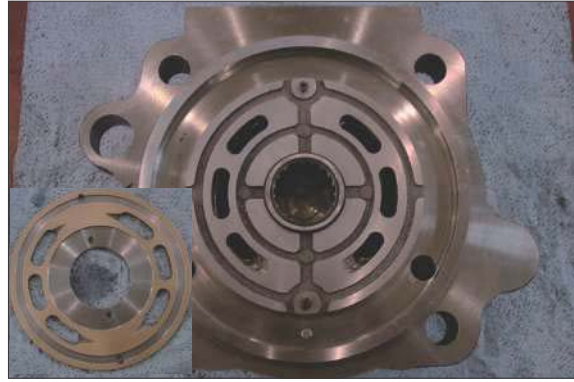

14078SM212/212A

- ② Using a torque wrench, disassemble relief valve assy (31) 2 set from rear cover (21).



14078SM213/213A

- ③ After disassembling plug with a L-wrench from rear cover (21), disassemble respectively back up ring, O-ring, O-ring, spring, anti-inversion valve assy (32)

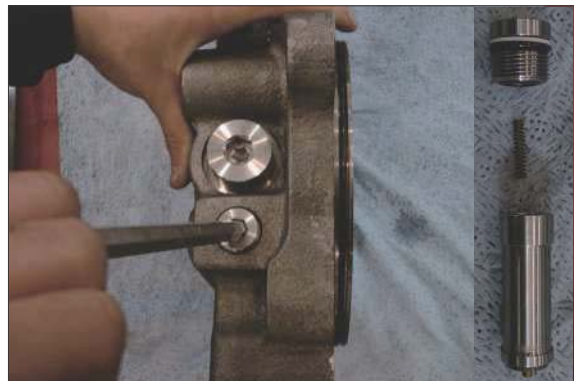

14078SM214/214A

- ④ Disassemble make up check valve assy with a torque wrench from rear cover (21).



14078SM215/215A

- ⑤ Disassemble respectively plug (35, 38, 39), with a L-wrench from rear cover (21).

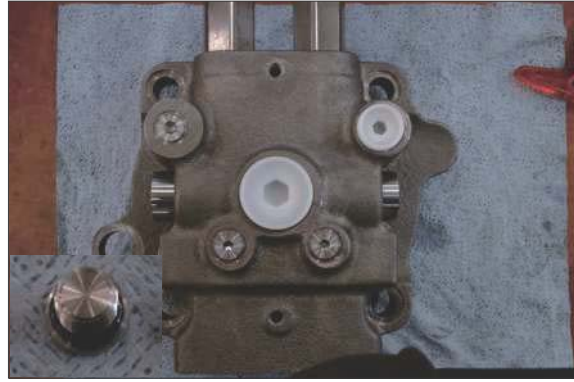

14078SM216/216A

3) ASSEMBLING

(1) Assemble the sub of a turning axls

- ① Put roller bearing (3), bushing (6) on pre-heater and provide heat to inner wheel (compressing temp : 290°C for 2minutes)
 - Roller bearing × 1 EA
 - Bushing × 1 EA

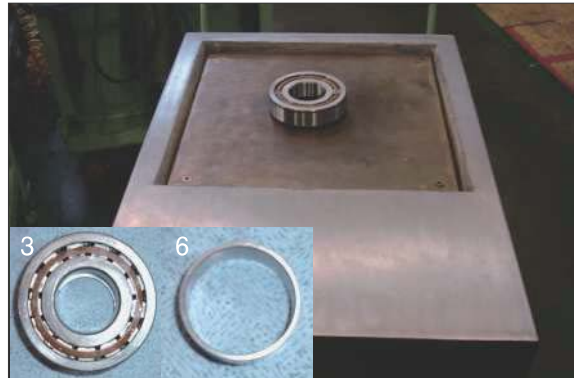

14078SM217/217A/B

- ② After assembling and compressing pre-heated roller bearing (3), bushing (6) into shaft (5).
 - Stop ring × 1 EA
 - Shaft × 1 EA



14078SM218/218A/B

- ③ Put body (1) on a assembling jig, fix it with bolts to prohibit moving.



14078SM219

- ④ Using a compressing tool and steel stick, assemble oil seal (2) into body (1).
· Oil seal × 1 EA

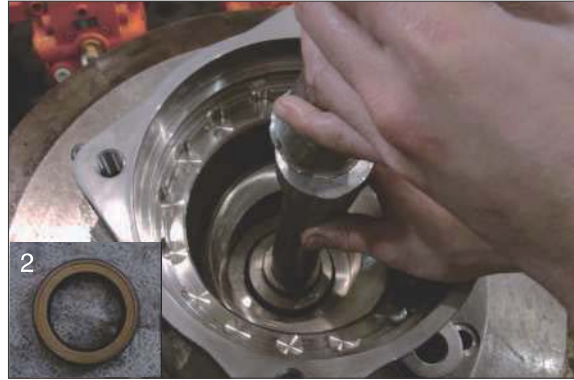

- ⑤ Insert above shaft sub into body (1) and assemble it with a steel stick.

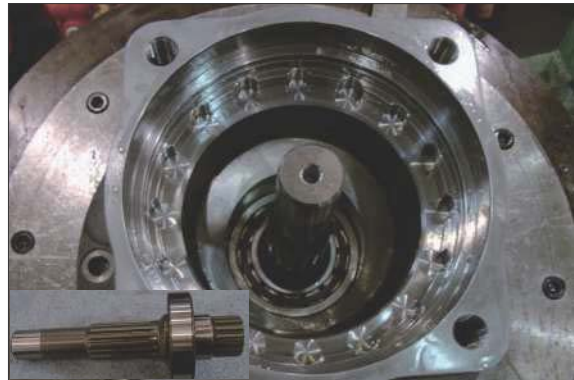

- ⑥ Fix snap ring (4) to shaft with a plier jig.

· Snap ring × 1 EA



- ⑦ Spread grease on shoe plate (9) and assemble on the body.

· Shoe plate × 1 EA



(2) Assemble the sub of cylinder block assy

- ① Assemble spring (11) 9 set into cylinder block (10).
· Spring × 9 EA

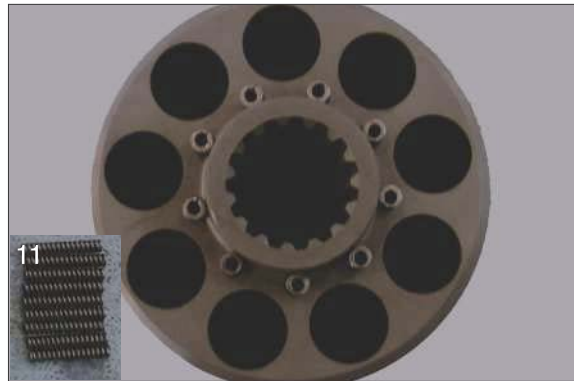

14078SM208/208A

- ② Assemble ball guide (12) into cylinder.
· Ball guide × 1 EA



14078SM207/207A

- ③ Assemble piston assy (14) 9 set into set plate (13).
· Piston assy × 9 EA
· Set plate × 1 EA



14078SM223/223A

- ④ Assemble above item ② and ③.



14078SM224

- ⑤ Assemble cylinder block assy into body (1).



14078SM225

- ⑥ Assemble O-ring (18) into body (1).
· O-ring × 1 EA

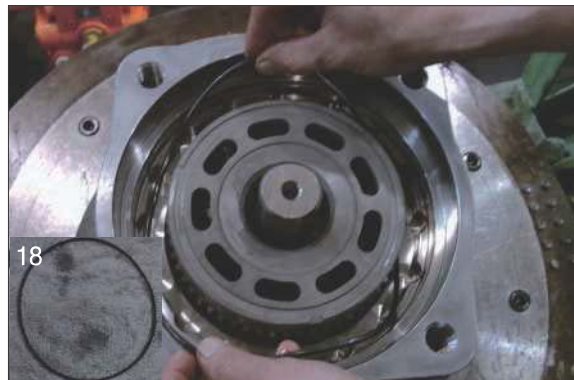

14078SM226/226A

- ⑦ Assemble 3 set of plate (16), friction plate (15) respectively into body.
· Plate × 3 EA
· Friction plate × 3 EA



14078SM227/205A

- ⑧ Assemble O-ring (19) into break piston (17).
· O-ring × 2 EA



14078SM228/226A

- ⑨ Insert break piston assy into body (1) and compress it with a jig and hammer.

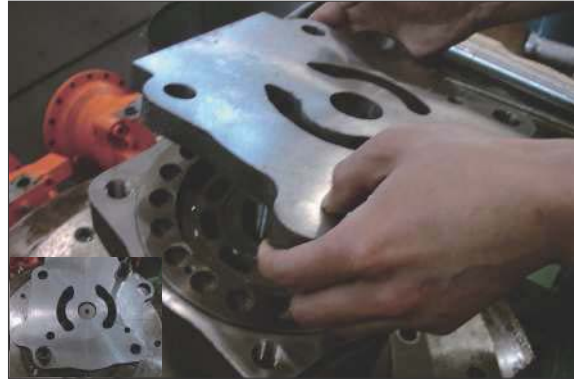

14078SM229/229A

- ⑩ Assemble spring (20) (20 EA) into break piston (17).
 · Spring × 20 EA



14078SM230/230A

(3) Assemble the sub of rear cover assy sub

- ① Assemble the sub of make up check valve assy.
 Assemble O-ring (28), back up ring (27) into plug (26) with a O-ring assembling jig.
 · Plug × 1 EA
 · Back up ring × 1 EA
 · O-ring × 1 EA



16098SM231/231A/B

- ② Assemble respectively make up check valve assy spring (29), check (30), plug (26) into rear cover (21) after then screw it torque wrench.
 · Make up check sub × 2 set
 · Spring × 2 EA
 · Check × 3 EA

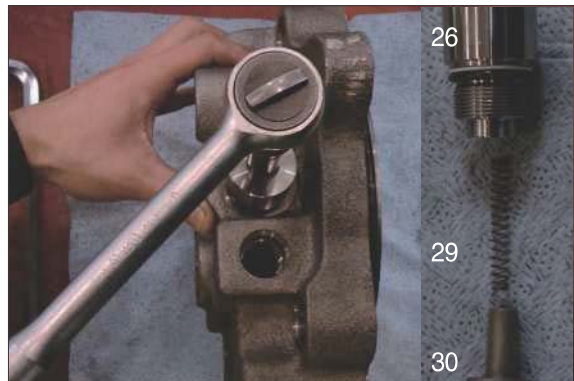

16098SM215/215A

- ③ Assemble respectively plug (43), back up ring, O-ring, O-ring, spring, anti-inversion valve assy (32) into rear cover (21).
(Bilateral symmetry assembling)
- Anti-Inversion v/v assy × 2 set
 - O-ring (P12) × 2 EA
 - O-ring (P18) × 2 EA
 - Back up ring (P18) × 2 EA

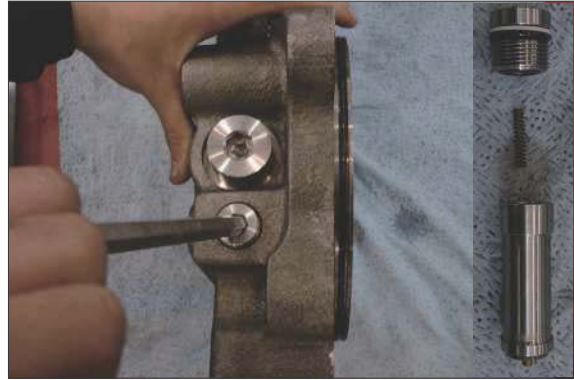

14078SM214/214A

- ④ Assemble relief valve assy (31) 2set into rear cover (21) with a torque wrench.
(Bilateral symmetry assembling)

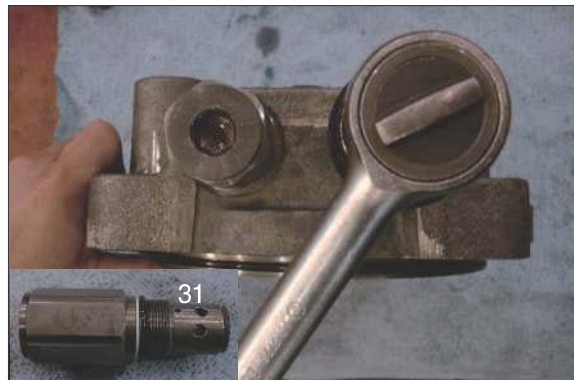

16098SM213/213A

- ⑤ Assemble plug (35), plug (38, 39) into rear cover (21) with a L-wrench.
* Plug × 3 EA (PF1/4)

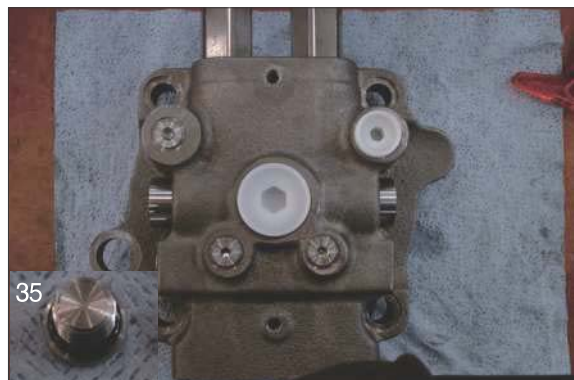

16098SM216/216A

- ⑥ After assembling needle bearing (22) into rear cover (21), with a hammer assemble pin (8, 23).
* Pin × 1 EA
* Pin × 2 EA



14078SM212

- ⑦ Spreading grease on valve plate (24),
assemble into rear cover (21).
· Valve plate × 1 EA

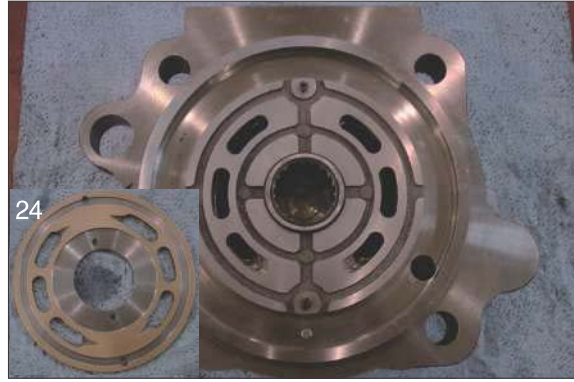

14078SM212/212A

- ⑧ Lift up rear cover assy on body (1) by a crane and assemble it with a wrench bolt (25).



14078SM203/203A

- ⑨ Assemble level gauge (42) into body (1).

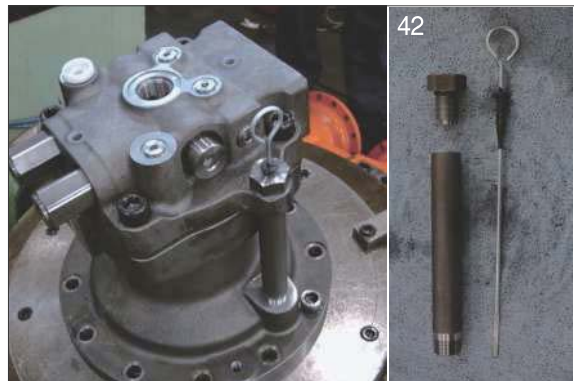

16098SM202/202A

- ⑩ Assemble time delay valve assy (33) into rear cover (21) with a wrench bolt (34).

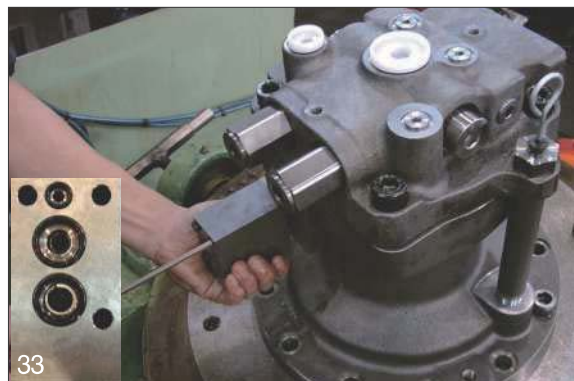

16098SM201/201A

(4) Air pressing test

Be sure of leakage, after press air into assembled motor



14078SM232

(5) Leakage check

After cleaning motor by color check No.1, paint No.3 and be sure of leakage.



14078SM233/233A

(6) Mount test bench

Mounting motor test bench, test the availability of each part.



220078SM14

3. REMOVAL AND INSTALL OF REDUCTION GEAR

1) REMOVAL

- (1) Remove the swing motor assembly.
For details, see removal of swing motor assembly.
- (2) Sling reduction gear assembly (1) and remove mounting bolts (2).
- (3) Remove the reduction gear assembly.
 - Reduction gear device weight : 180 kg (396 lb)



2) INSTALL

- (1) Carry out installation in the reverse order to removal.
 - Tightening torque : 57.9 ± 8.7 kgf · m (419 ± 62.9 lbf · ft)

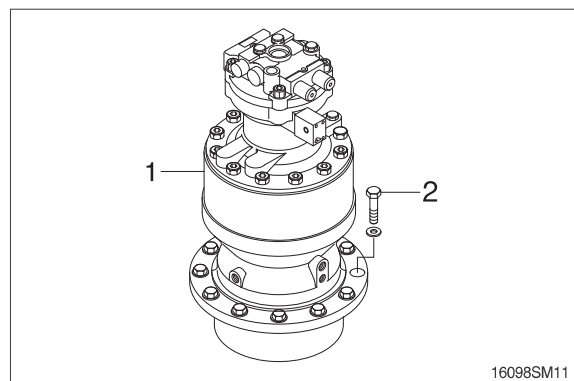

4. DISASSEMBLY AND ASSEMBLY OF REDUCTION GEAR

1) STRUCTURE

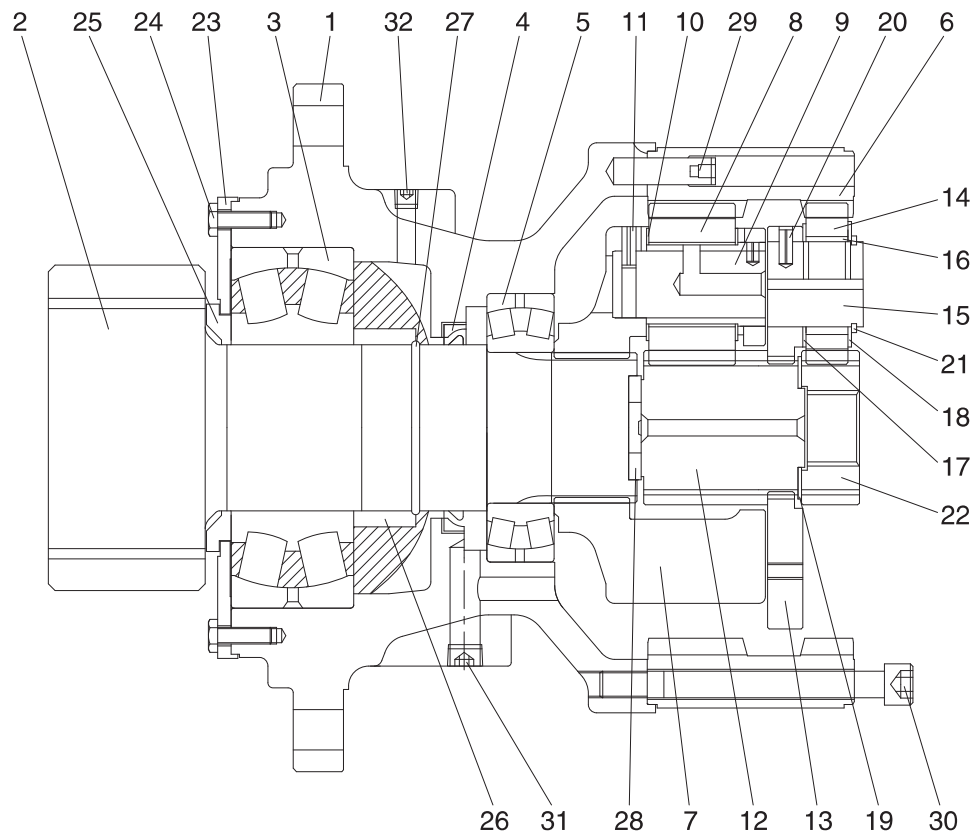

160F2SM05

1	Casing	12	Sun gear 2	23	Cover plate
2	Drive shaft	13	Carrier 1	24	Hexagon bolt
3	Roller bearing	14	Planet gear 1	25	Spacer
4	Oil seal	15	Pin 1	26	Spacer pipe
5	Roller bearing	16	Needle cage	27	Wire
6	Ring gear	17	Side plate 1	28	Thrust plate
7	Carrier 2	18	Side plate 2	29	Knock pin
8	Planet gear 2	19	Side plate 3	30	Socket bolt
9	Pin 2	20	Spring pin	31	Plug
10	Thrust washer	21	Stop ring	32	Plug
11	Spring pin	22	Sun gear 1		

2) DISASSEMBLY

- (1) Remove gauge bar and gauge pipe from the swing motor casing.
 - ※ Pour the gear oil out of reduction gear into the clean bowl to check out the friction decrease.

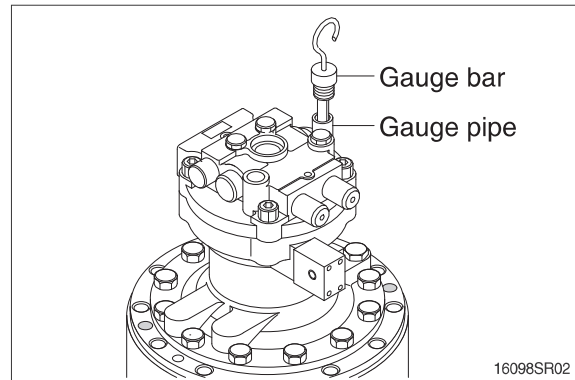

- (2) Loosen the socket bolts (30) to separate swing motor from reduction gear.

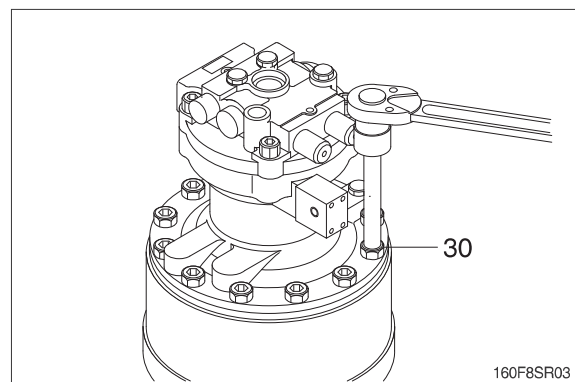

- (3) Tighten 3 M16 eye bolts to the ring gear (6) and then lift the ring gear (6) out of the casing (1).

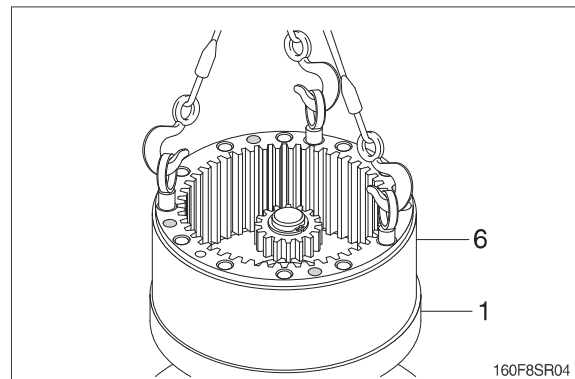

- (4) Remove sun gear1 (22) from side plate 3 (19).

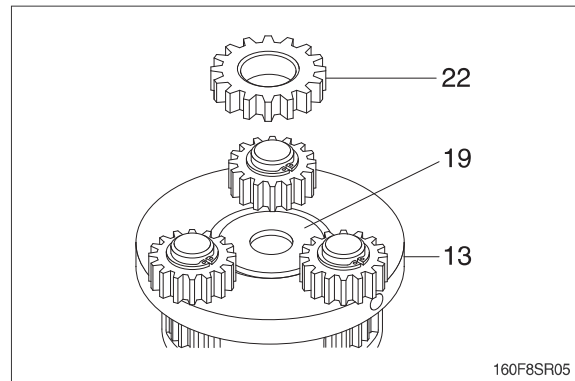

- (5) Tighten two M10 eye bolts to carrier 1 (13) and lift up and remove carrier 1 (13) as subassembly.

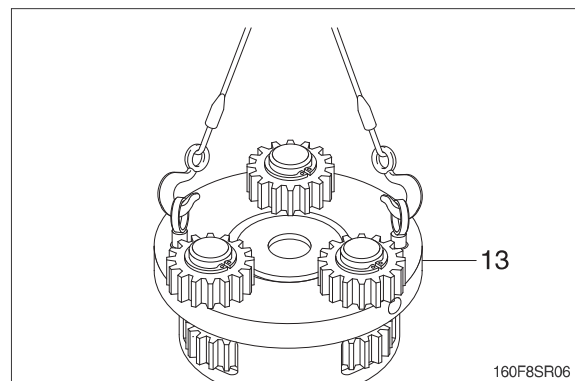

- (6) Disassembling carrier 1 (13) assembly.

- ① Remove stop ring (21).
 - ② Remove side plate 2 (23), planet gear 1 (14), needle cage (16), side plate 1 (17) and side plate 3 (19) from the carrier.
 - ③ Using M8 solid drill, crush spring pin (20) so that the pin 1 (15) can be removed by hammering.
 - ④ Remove side plate 3 (19) from carrier 1 (13).
- ※ Do not reuse spring pin (20).
 - ※ Do not remove pin 1 (15), carrier 1 (13) and spring pin (20) but in case of replacement.
 - ※ Put matching marks on the planet gear 1 (14) and the pin 1 (15) for easy reassembly.

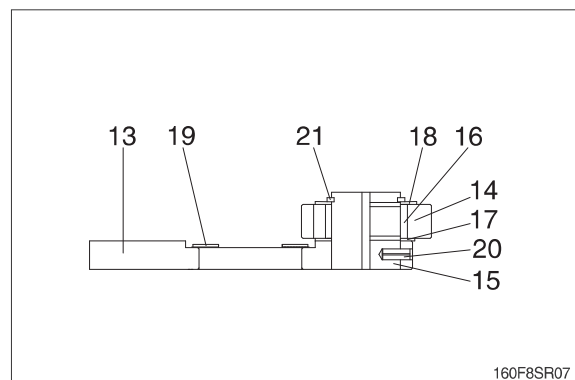

(7) Remove sun gear 2 (12) from carrier 2 (7).

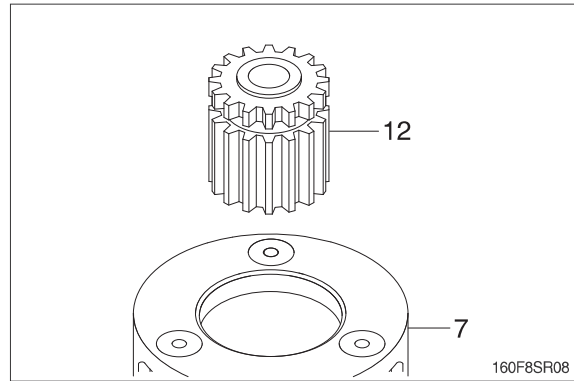

(8) Remove carrier 2 (7) assembly from casing (1).

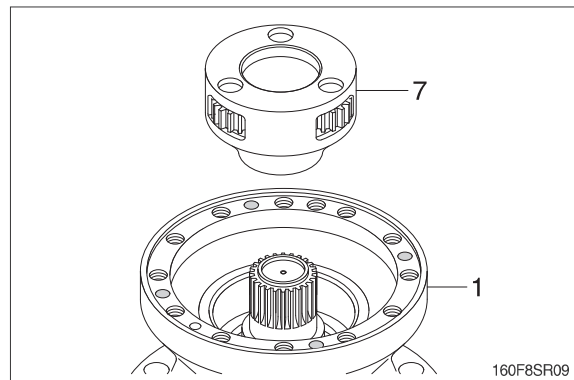

(9) Disassembling carrier 2 (7) assembly

① Using M8 solid drill, crush spring pin (11) so that the pin assembly (9) can be removed.

※ Do not reuse spring pin (11).

② Remove pin assembly (9), planet gear 2 (8) from the carrier 2 (7).

※ Put matching marks on the planet gear 2 (8) and the pin assembly (9) for easy reassembly.

※ Do not disassemble pin assembly (9), carrier 2 (7) and spring pin (11) but in case of replacement.

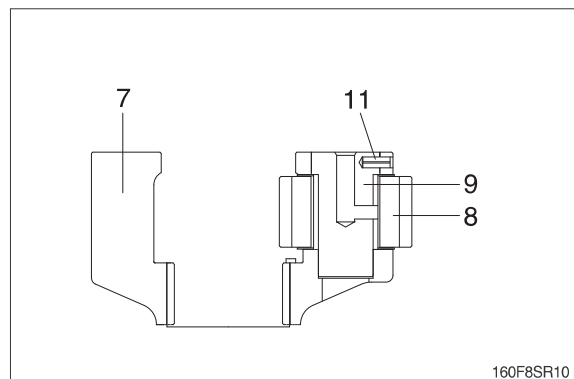

(10) Remove thrust plate 3 (28) from the drive shaft (2).

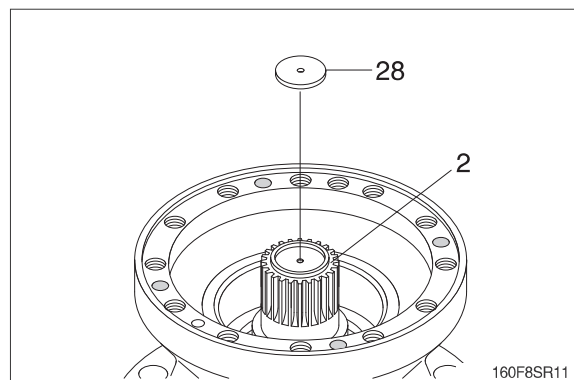

- (11) Remove drive shaft (2) with roller bearing (3) and oil seal (4) assembled.
Remove knock pin (29) from the casing (1).

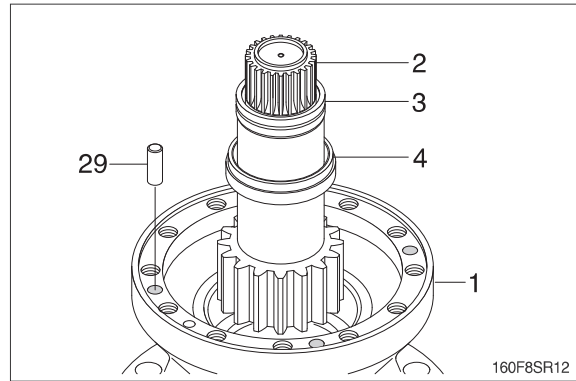

- (12) Remove roller bearing (5) and oil seal (4) from the drive shaft (2).
※ Do not reuse oil seal (5) once removed.

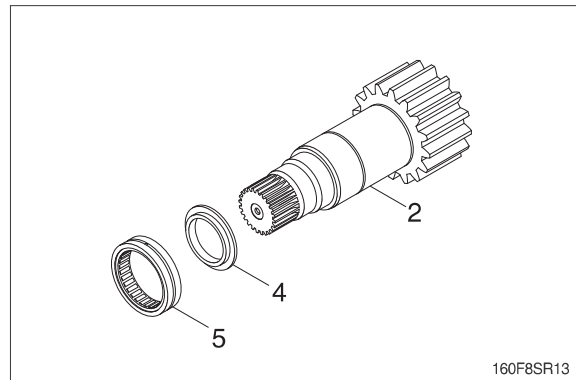

- (13) Using the bearing disassembly tool, remove roller bearing (3).

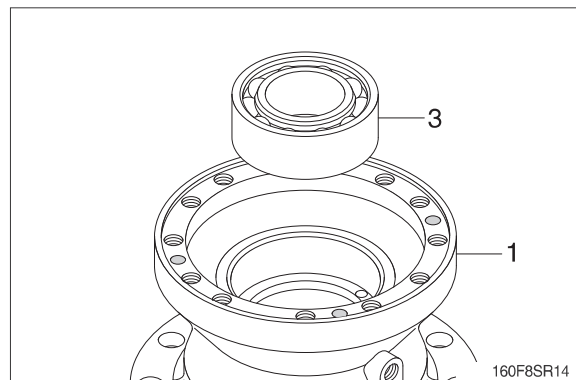

- (14) Remove plugs (31, 32) from the casing (1).

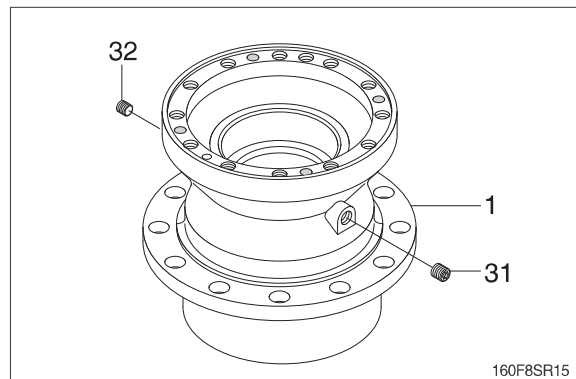

3) ASSEMBLY

- (1) Assemble roller bearing (3) inside the casing (1).

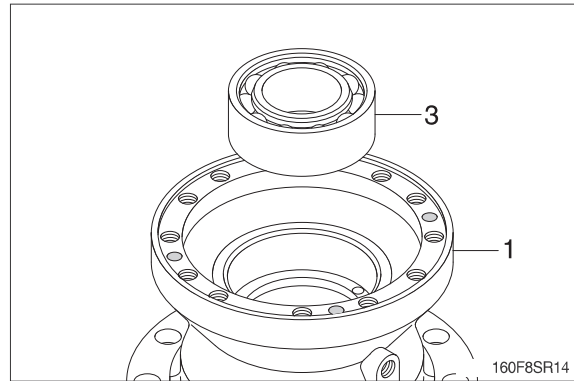

- (2) Assemble the drive shaft (2) into the casing (1) and then install oil seal (4) and roller bearing (5).

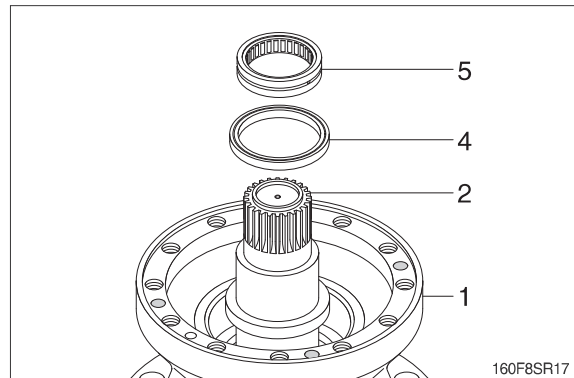

- (3) Install thrust plate 3 (28) on top of drive shaft (2).

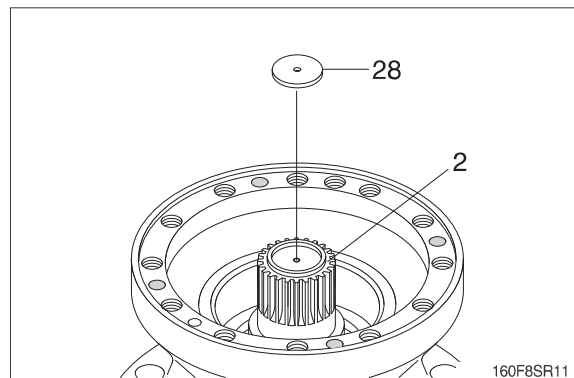

- (4) Assembling carrier 2 (7) assembly.

- ① Install thrust washer (10) inside the carrier 2 (7).
 - ② Assemble planetary gear 2 (8) to the carrier 2 (7).
 - ③ Assemble the pin assembly (12) to the carrier 2 (7) and then press the spring pin (11) by hammering.
 - ④ Punch 2 points of the spring pin (11) lip.
- ※ Take care not to mistake the matching marks of each part.

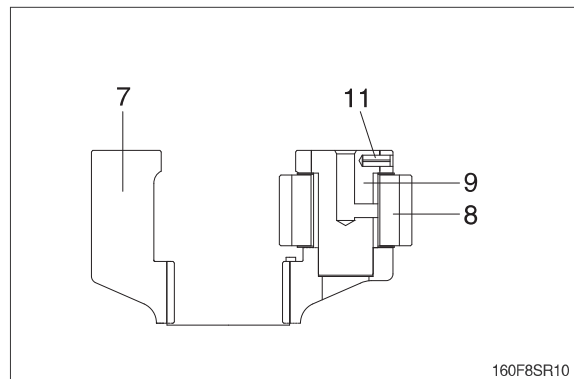

- (5) Assemble carrier 2 (7) assembly correctly to the drive shaft (2).

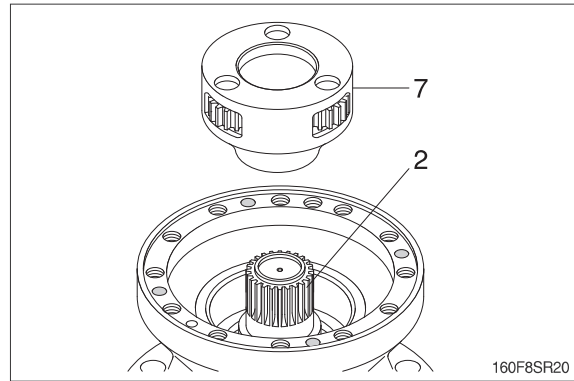

- (6) Assemble sun gear 2 (12) to the center of the carrier 2 (7) assembly.

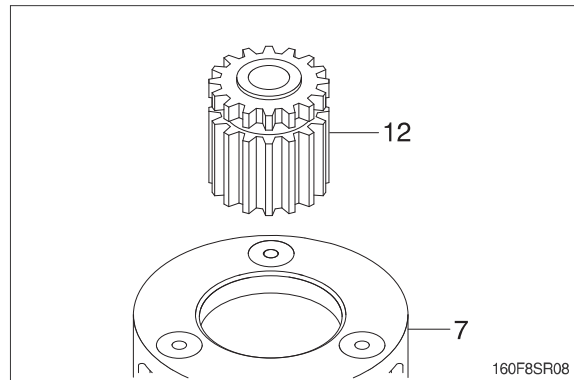

- (7) Assembling carrier 1 (13) assembly.

- ① Assemble the pin 1 (15) to the carrier 1 (13) and then press the spring pin (20) by hammering.
 - ② Punch 2 points of the spring pin's (20) lip.
 - ③ Install side plate 3 (19) onto the center of carrier 1 (15).
 - ④ Install needle cage (16) into the planet gear 1 (18).
 - ⑤ Assemble side plate (17), planet gear 1 (14), side plate 2 (18) and then stop ring (21) to the pin 1 (15).
- ※ Take care not to mistake the matching marks of each part.

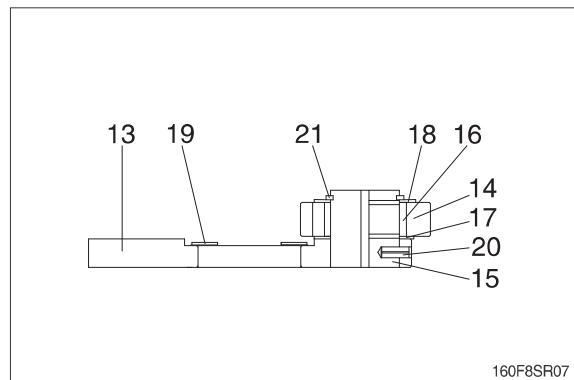

- (8) Install sun gear 1 (22) onto the side plate 3 (19).

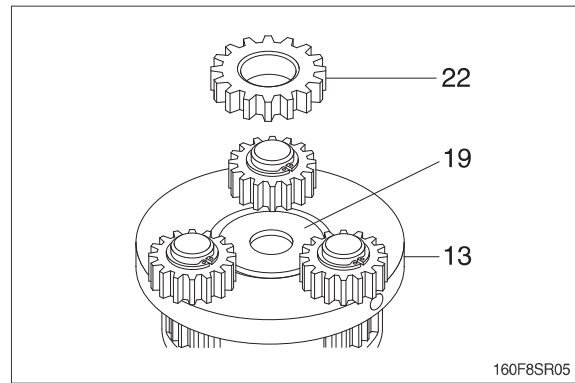

- (9) Assemble carrier 1 (13) assembly onto the carrier 2 (7) assembly.

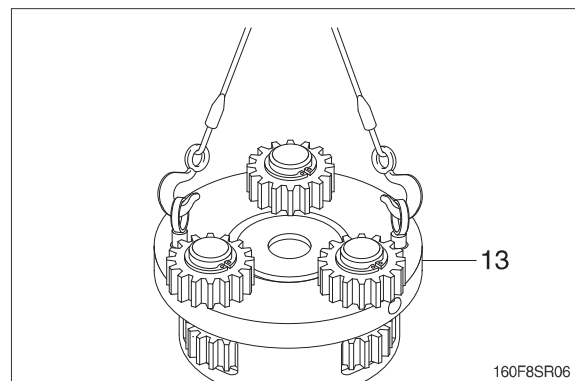

- (10) Apply loctite to the tapped holes of casing (1).

- (11) Tighten 3 M16 eye bolts to the ring gear (6) and lift up and then assemble it onto the casing (1).

- ※ Don't fail to coincide the knock pin (29) holes.

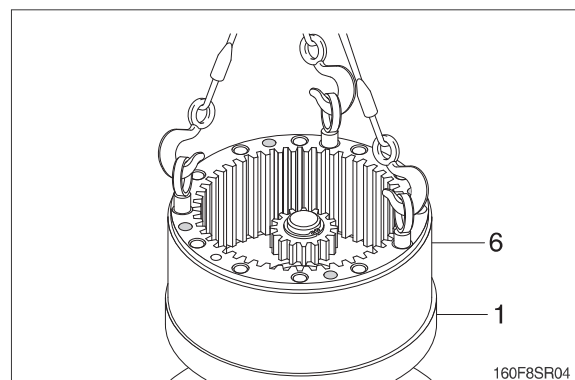

- (12) Hammer 4 knock pins (29) around the ring gear (6).

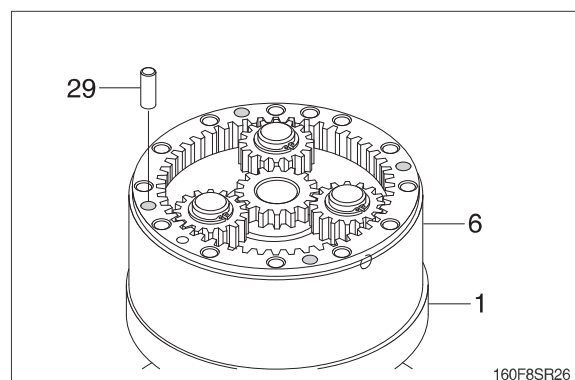

(13) Apply loctite to the tapped holes of the ring gear (6) and then mount swing motor onto the ring gear (6).

※ Don't fail to coincide the gauge bar hole.

(14) Tighten socket bolts (30) around the swing motor assembly.

- Tightening torque : 24 ± 2.5 kgf · m
(173 ± 18.1 lbf · ft)

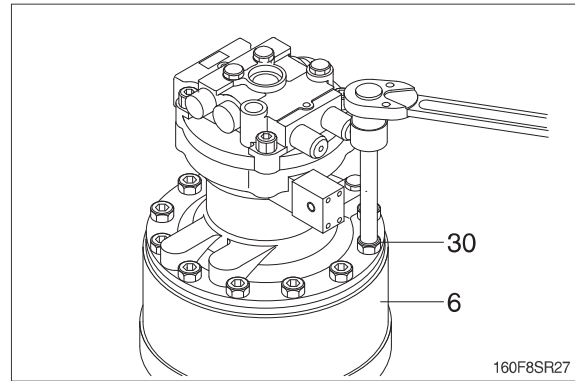

(15) Assemble plugs (31, 32) to the casing (1).

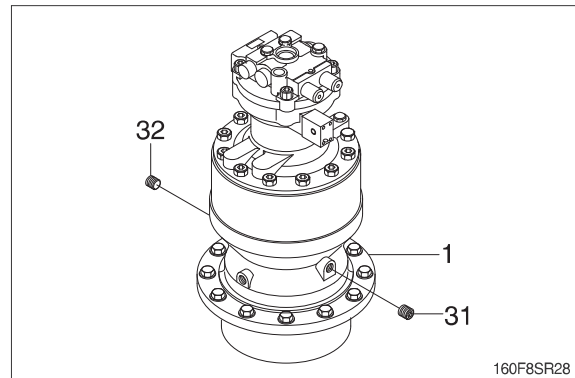

GROUP 5 SWING DEVICE (TYPE 2)

1. REMOVAL AND INSTALL OF MOTOR

1) REMOVAL

- (1) Lower the work equipment to the ground and stop the engine.
- (2) Operate the control levers and pedals several times to release the remaining pressure in the hydraulic piping.
- (3) Loosen the breather slowly to release the pressure inside the hydraulic tank.

▲ Escaping fluid under pressure can penetrate the skin causing serious injury.

※ When pipes and hoses are disconnected, the oil inside the piping will flow out, so catch it in oil pan.

- (4) Disconnect hose assembly (2).
- (5) Disconnect pilot line hoses (3, 4, 5, 6, 7, 8).
- (6) Sling the swing motor assembly (1) and remove the swing motor mounting socket bolts (9).

· Motor device weight : 61 kg (135 lb)

- (7) Remove the swing motor assembly.
※ When removing the swing motor assembly, check that all the piping have been disconnected.

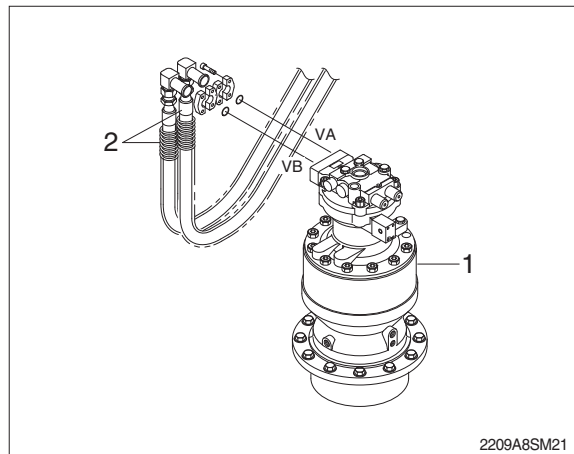

2) INSTALL

- (1) Carry out installation in the reverse order to removal.
- (2) Bleed the air from the swing motor.
 - ① Remove the air vent plug.
 - ② Pour in hydraulic oil until it overflows from the port.
 - ③ Tighten plug lightly.
 - ④ Start the engine, run at low idling and check oil come out from plug.
 - ⑤ Tighten plug fully.
- (3) Confirm the hydraulic oil level and check the hydraulic oil leak or not.

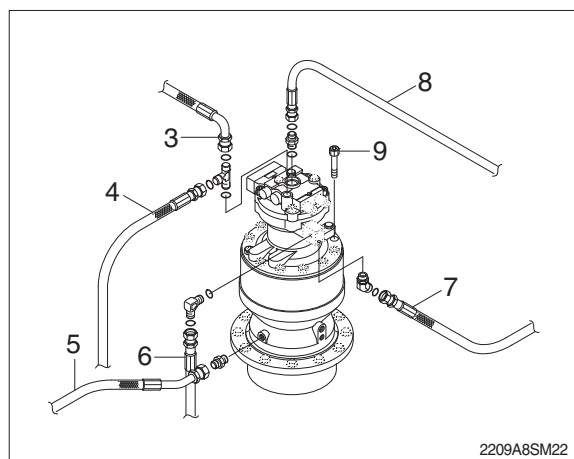

2. DISASSEMBLY AND ASSEMBLY OF SWING MOTOR

1) STRUCTURE

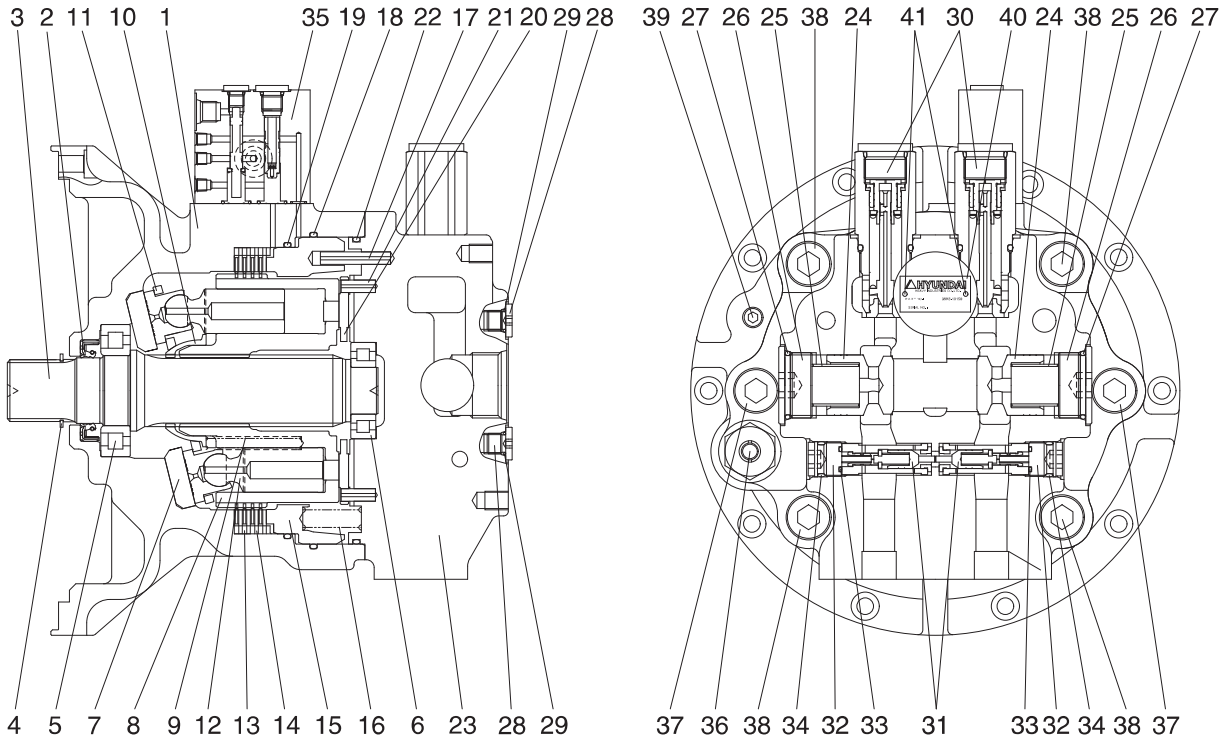

220L2SM02

- | | | | | | |
|----|----------------|----|----------------|----|-------------------------|
| 1 | Casing | 15 | Parking piston | 29 | O-ring |
| 2 | Oil seal | 16 | Spring | 30 | Relief valve assy |
| 3 | Shaft | 17 | Spring pin | 31 | Reactionless valve assy |
| 4 | Snap ring | 18 | O-ring | 32 | Plug |
| 5 | Roller bearing | 19 | O-ring | 33 | O-ring |
| 6 | Needle bearing | 20 | Valve plate | 34 | O-ring |
| 7 | Swash plate | 21 | Spring pin | 35 | Time delay valve assy |
| 8 | Cylinder block | 22 | O-ring | 36 | Level gauge |
| 9 | Spring | 23 | Valve casing | 37 | Socket bolt |
| 10 | Ball guide | 24 | Check valve | 38 | Socket bolt |
| 11 | Retainer plate | 25 | Spring | 39 | Plug |
| 12 | Piston assy | 26 | Plug | 40 | Name plate |
| 13 | Friction plate | 27 | O-ring | 41 | Rivet |
| 14 | Separate plate | 28 | Plug | | |

2) DISASSEMBLY

(1) Disassemble drive shaft

- ① Unloosing socket bolt (time delay valve, 42) and disassemble time delay valve assy (35) from casing (1).



2209A8SM51

- ② Disassemble level gauge (36) from casing (1).



2209A8SM52

- ③ Hang valve casing (23) on hoist, unloose socket bolt (37, 38) and disassemble from casing (1).



2209A8SM53

- ④ Disassemble spring (16) and using a jig, disassemble parking piston (15) from casing (1).

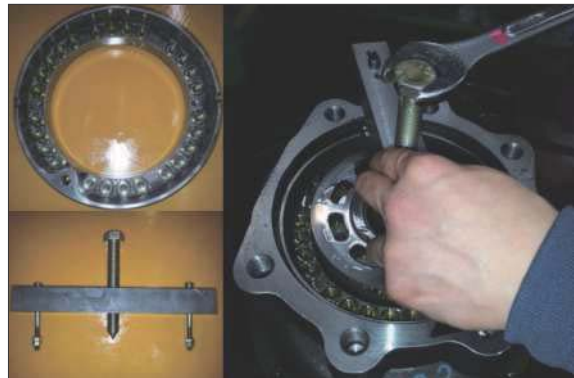

2209A8SM54

- ⑤ Disassemble respectively cylinder block sub (8), friction plate (13), separate plate (14) from casing (1).



2209A8SM55

- ⑥ Disassemble swash plate (7) from casing (1).



2209A8SM56

- ⑦ Using a plier jig, disassemble snap ring (4) from casing (1).



2209A8SM57

- ⑧ Disassemble shaft assy (3), oil seal (2) and O-ring (18, 22) from casing (1).



2209A8SM58

(2) Disassemble cylinder block sub

- ① Disassemble piston assy (12) from cylinder block (8).



2209A8SM59

- ② Disassemble ball guide (10) and spring (cylinder block, 9) from cylinder block (8).
 - Ball guide × 1EA
 - Spring × 9EA



2209A8SM60

(3) Disassemble valve casing sub

- ① Disassemble spring pin (17, 21), valve plate (20), O-ring (22) from valve casing (23).



2209A8SM61

- ② Using a torque wrench, disassemble relief valve (30) from valve casing (23).



2209A8SM62

- ③ Using a torque wrench, disassemble plug (32) from valve casing (23) and disassemble O-ring (33, 34) and reaction-less valve assy (31).



2209A8SM63

- ④ Using a torque wrench, disassemble check valve (24) from valve casing (23).

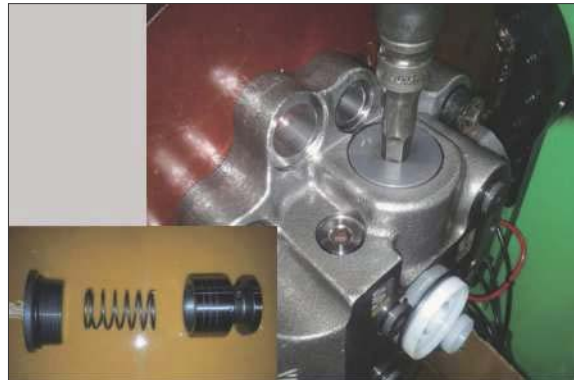

2209A8SM64

- ⑤ Disassemble plug (28), O-ring (29) from valve casing (23).



2209A8SM65

3) ASSEMBLING

(1) Assemble shaft sub

- ① Put roller bearing (3) on preheater and provide heat to inner race.
(Temperature in conveyor : 120°C for 3~5 minutes)



2209A8SM66

- ② Using a robot machine, assemble and press preheated roller bearing (3) into shaft (5).



2209A8SM67

(2) Assemble cylinder block sub

- ① Assemble 9 springs (cylinder block, 9) into cylinder block (8).
 - Spring × 9EA



2209A8SM68

- ② Assemble ball guide (10) into cylinder block (8).
 - Ball guide × 1EA



2209A8SM69

③ Assemble 9 piston assy (12) into retainer plate (11).

- Piston assy × 9EA
- Retainer plate × 1EA



2209A8SM70

④ Assemble parts of procedure ② and ③.



2209A8SM71

(3) Assemble valve casing sub

① Assemble make up check valve sub

Assemble check valve (24), O-ring (27), plug (26) in that order and then screw it torque wrench.

- Make up check valve × 2EA
- Spring × 2EA
- Plug × 2EA
- O-ring × 2EA



2209A8SM72

② Assemble reactionless valve assy

Assemble reactionless valve assy (31), plug (32), O-ring (33, 34) in that order and then screw it a torque wrench.

- Reactionless valve assy (31) × 2EA
- Plug (32) × 2EA
- O-ring (33, 34) × 2EA



2209A8SM73

- ③ Using a torque wrench, assemble relief valve (30) 2 sets into valve casing (23).
- Relief valve (30) × 2EA



2209A8SM74

- ④ Assemble plug (28) and O-ring (27) into valve casing (23).
- Plug (28) × 3EA
 - O-ring (27) × 3EA



2209A8SM75

- ⑤ Assemble needle bearing (6) into valve casing (23) and assemble spring pin (17, 21) into valve casing (23).
- Needle bearing (6) × 1EA
 - Spring pin (17, 21) × 1EA



2209A8SM76

- ⑥ Apply some grease valve plate (20) and assemble it into valve casing (23).



2209A8SM77

(4) Assemble drive shaft sub

- ① Using a jig, assemble oil sealing (2) into casing (1).



2209A8SM78

- ② Fit shaft sub (shaft+roller bearing) into casing (1).



2209A8SM79

- ③ Using a plier jig, assemble snap ring (4) to shaft (3).
 - Snap ring × 1EA



2209A8SM80

- ④ Apply some grease swash plate (7) and assemble it into casing (1).
 - Swash plate × 1EA



2209A8SM81

⑤ Insert O-ring (18, 19) into casing (1).

- O-ring (18) × 1EA
- O-ring (19) × 1EA



2209A8SM82

⑥ Assemble cylinder block (8) into casing (1).



2209A8SM83

⑦ Assemble separate plate (14) and friction plate (13) 4 sets into casing (1) and fit parking piston (15) into casing (1) by a jig or a press.

- Separate plate × 4EA
- Friction plate × 4EA
- Parking piston × 1EA



2209A8SM84

⑧ Assemble spring (parking piston, 16) into parking piston (15).

- Spring × 26EA



2209A8SM85

- ⑨ Lift up valve casing (23) on casing (1) by a crane and assemble it with socket bolts (37, 38).



2209A8SM86

- ⑩ Assemble level gauge (36) and plug (39) into casing (1).



2209A8SM87

- ⑪ Assemble time delay valve assy (35) into valve casing (23) with socket bolt (42).
- Time delay valve × 1EA
 - Socket bolt × 3EA



2209A8SM88

⑫ **Air pressing test**

Be sure of leakage, after press air into assembled motor and put it in water for 1 minute (pressure : 2 kgf/cm²).



2209A8SM89

⑬ **Leakage check**

Place motor on a bench tester and after cleaning motor by color check No.1, paint No.3 and be sure of leakage.



2209A8SM90

⑭ **Mount test bench**

Mounting motor a test bench, test the availability of each part.



2209A8SM91

3. DISASSEMBLY AND ASSEMBLY OF REDUCTION GEAR

1) STRUCTURE

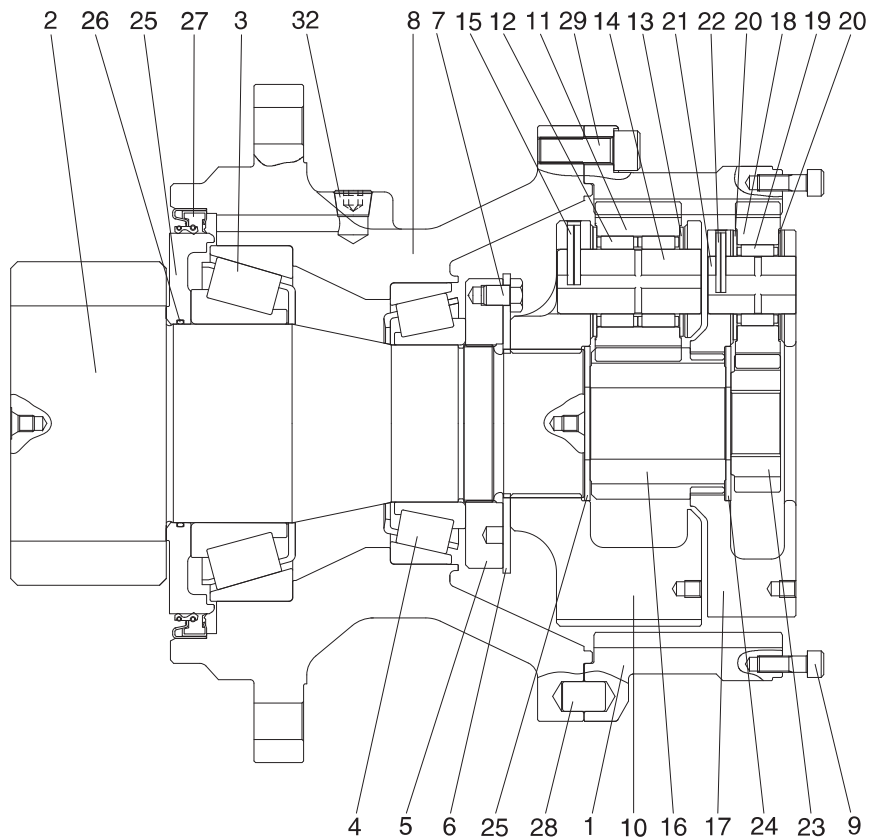

160F2SM03

1	Ring gear	11	Planetary gear 2	21	Carrier pin 1
2	Drive shaft	12	Needle bearing 2	22	Spring pin 1
3	Taper bearing	13	Thrust washer 2	23	Sun gear 1
4	Taper bearing	14	Carrier pin 2	24	Thrust plate
5	Ring nut	15	Spring pin 2	25	Sleeve
6	Lock plate	16	Sun gear 2	26	O-ring
7	Hexagon bolt	17	Carrier 1	27	Oil seal
8	Casing	18	Planetary gear 1	28	Parallel pin
9	Socket bolt	19	Needle bearing 1	29	Socket bolt
10	Carrier 2	20	Thrust washer 1	32	Plug

2) DISASSEMBLY

(1) Preparation

- ① The reduction gear removed from machine is usually covered with mud.
Wash out side of reduction gear and dry it.
 - ② Setting reduction gear on work stand for disassembling.
 - ③ Mark for mating
Put marks on each mating parts when disassembling so as to reassemble correctly as before.
- ▲ Take great care not to pinch your hand between parts while disassembling not let fall parts on your foot while lifting them.



2209A8SM01

(2) Disassembly

- ① Remove every "Socket bolt (M10)" that secure swing motor and reduction gear.
- ② Removing carrier sub assy & sun gear
 - a. Removing No.1 sun gear from No.1 carrier sub assy.
※ Be sure maintaining it vertical with ground when disassembling No.1 sun gear.



2209A8SM02

- b. Removing No.1 carrier sub assy screwing I-bolt to tab hole (M10) in No.1 carrier.
Lifting it gradually maintaining it vertical with ground.
※ It's impossible to disassemble No.1 spring pin. If No.1 spring pin has problem, change whole No.1 carrier sub assy.



2209A8SM03

c. Removing No.2 sun gear from No.2 carrier sub assy.

※ Be sure maintaining it vertical with ground when disassembling No.2 sun gear.



2209A8SM04

d. Removing No.2 carrier sub assy screwing I-bolt to tab hole (M10) in No.2 carrier. Lifting it gradually maintaining it vertical with ground.

※ It's impossible to disassemble No.2 spring pin. If No.2 spring pin has problem, change whole No.2 carrier sub assy.



2209A8SM05

③ Removing ring gear

After unscrewing every socket bolt (M16), remove ring gear from casing.

※ Because of liquid gaskets between ring gear and casing, put sharp punch between ring gear and casing and tapping it to remove them.



2209A8SM06

④ Removing drive shaft sub assy

- a. Unscrew every hex head bolt (M12) to remove lock plate.



2209A8SM07

- b. Rolling ring nut for removing them from drive shaft sub assy.

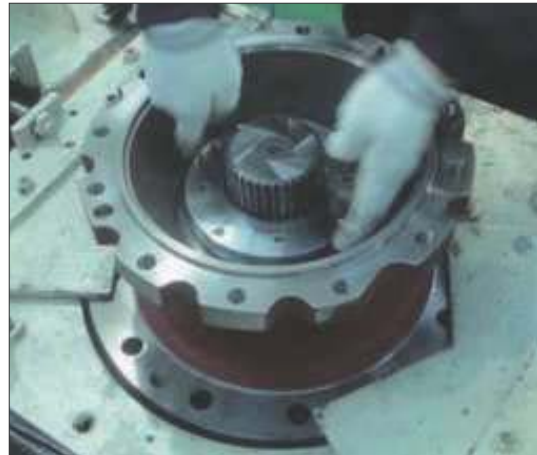

2209A8SM08

- ※ Use special tool to roll ring nut to counter clockwise.

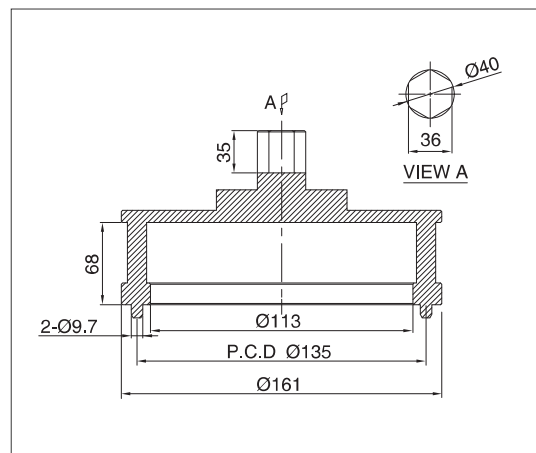

220L8SM01

- c. Remove drive shaft sub assy from casing.
※ Set a rack for flange of casing, and remove drive shaft sub assy from casing by using press.



2209A8SM09

- d. Remove oil seal & taper bearing (small) from casing.
※ Do not re-use oil seal. It is impossible to disassemble drive shaft sub assy.



2209A8SM10



2209A8SM11

4. ASSEMBLY REDUCTION UNIT

1) GENERAL NOTES

- (1) Clean every part by kerosene and dry them in a cool and dry place.
- (2) Loctite on surface must be removed by solvent.
- (3) Check every part for any abnormal.
- (4) Each hexagon socket head bolt should be used with loctite #242 applied on its threads.
- (5) Apply gear oil slightly on each part before assembling.

▲ Take great care not to pinch your hand between parts or tools while assembling nor let fall parts on your foot while lifting them.

Inspection before assembling.

Thrust washer

- Check the seizure, abnormal wear or uneven wear.
- Check the unallowable wear.

Gear

- Check the pitting or seizure on tooth surface.
- Check the cracks on the root of tooth.

Bearing

- Rotate it by hands to check such noise or uneven rotation.

2) ASSEMBLING NO.1 CARRIER SUB ASSY

- (1) Put thrust plate firmly in No.1 carrier.
- (2) After assembling No.1 needle bearing to No.1 planetary gear, put a pair of No.1 thrust washer on both sides of bearing and install them to No.1 carrier.



2209A8SM12



2209A8SM13

- (3) Make of spring pin hole No.1 pin and No.1 carrier of spring pin hole in line, press No.1 spring pin into the holes.
 Make No.1 spring pin hole head for No.1 planetary gear.



2209A8SM14

- (4) Caulk carrier holes to make No.1 spring pin settle down stably.



2209A8SM15

- ※ Refer to “Caulking details”
 Use paint marker for marking after caulking.

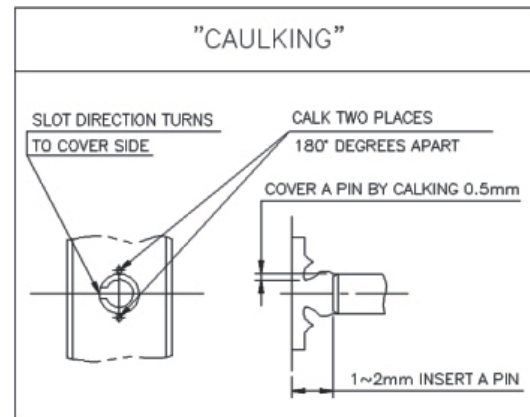

2209A8SM16

2) ASSEMBLING NO.2 CARRIER SUB ASSY

(1) Put thrust plate in firmly No.2 carrier.



2209A8SM17

(2) After assembling No.2 needle bearing to No.2 planetary gear, put 2 pieces of No.2 thrust washer on both sides of bearing and install them to No.2 carrier.



2209A8SM18

(3) Align No.2 spring pin hole and No.2 carrier spring pin hole, put No.2 spring pin into the holes.
Make No.2 spring pin cutting line face to No.2 planetary gear.



2209A8SM19

(4) Caulk carrier holes to make No.2 spring pin settle down stably.

※ Refer to "Caulking details"

Use paint marker for marking after caulking.

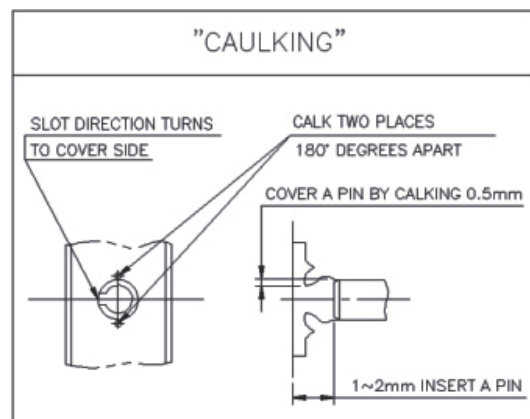

2209A8SM20

3) ASSEMBLING PINION GEAR SUB ASSY

- (1) Prepare drive shaft pinion gear vertical with ground.



2209A8SM21

- (2) Fully apply grease (albania EP02) to O-ring groove of sleeve.
※ Be sure to maintain it vertical with ground when assembling it.
- (3) Put O-ring into O-ring groove of sleeve.
Fully apply grease on O-ring.

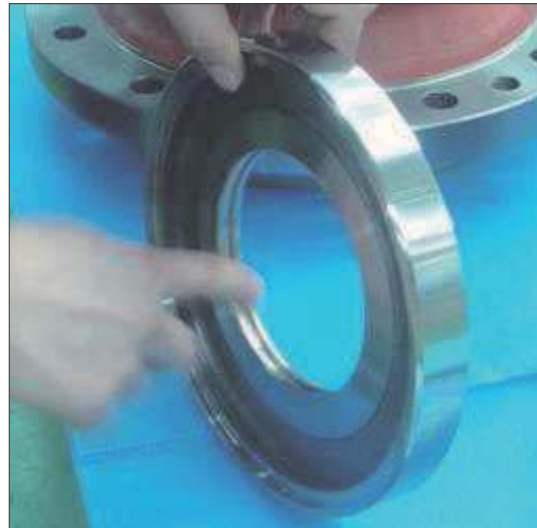

2209A8SM22

- (4) Assemble taper bearing and sleeve into drive shaft using press jig.
Use special jig for pressing. Leave no space between sleeve and taper bearing.



2209A8SM23



2209A8SM24

4) ASSEMBLING BEARING CUP & OIL SEAL (PRESSING)

- (1) Put top, bottom bearing cup into casing.
Use special jig for pressing. Pay attention to foreign materials while assembling bearing cup.
- ※ Flip over casing to assemble oil seal.



2209A8SM25



2209A8SM26

- (2) Assemble oil seal to casing.
Use special jig for pressing. Pay attention to direction of dust seal and dent.



2209A8SM27

※ WHILE ASSEMBLING OIL SEAL

1. Be sure to set dust seal to gear oil.
2. Before assembling, charge enough grease in oil seal.
3. Before assembling, apply enough grease inside and outside of oil seal.

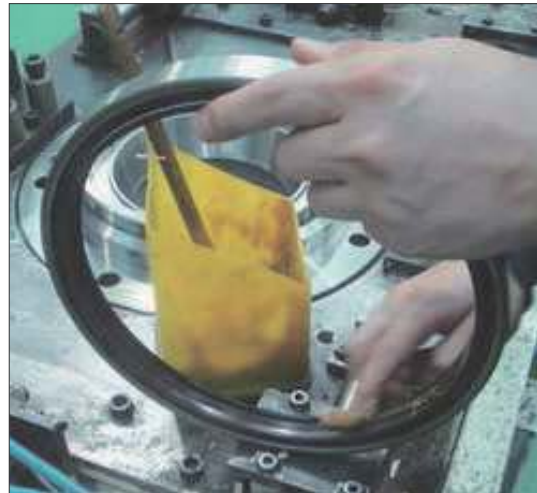

2209A8SM28

5) ASSEMBLING SHAFT SUB ASSY & RING NUT

- (1) After assembling casing & drive shaft sub assy, flip it over.



2209A8SM29

- (2) Put drive shaft sub assy into casing.
※ Be sure to maintain it vertical with ground when assembling it.



2209A8SM30

- (3) Put taper bearing into it.
Rotate bearing by hands for checking after assembly.



2209A8SM31

- (4) Put ring nut into drive shaft sub assy by using special jig.
The tightening torque (M95) = 3.5 ± 0.4 kgf·m
(25.3 ± 2.9 lbf·ft)



2209A8SM32

- ※ Apply enough loctite #242 before screwing bolts.

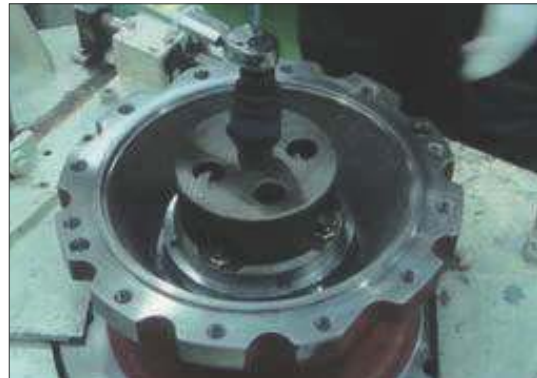

2209A8SM33

- (5) Align bolt screw of ring nut with lock plate's hole.

In case of misalign between bolt screw ring nut and lock plate's hole, put lock plate as near as possible to hole of bolt screw of ring nut and make it in line by increasing tightening torque.



2209A8SM34



2209A8SM35

- (6) Screw 4 bolts (M12×16) to connect ring nut and lock plate by using torque wrench.

Bolt (M12, 4EA) = 10.9T

The tightening torque = 8.8 ± 0.9 kgf·m
(63.7 ± 6.5 lbf·ft)

- ※ Apply enough loctite #242 before screwing bolts.



2209A8SM36

- (7) Use paint marker for checking surplus parts after assembling.



2209A8SM37

6) ASSEMBLING RING GEAR

- (1) Apply loctite #515 bottom of casing sub assy contacting with ring gear without disconnection.



2209A8SM38

Refer to loctite detail.

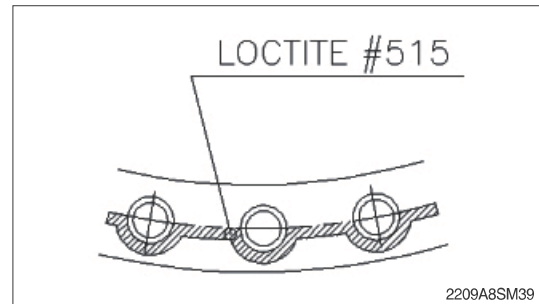

2209A8SM39

- (2) Put parallel pin into hole of casing sub assy.
Mark parallel pin position using paint marker.



2209A8SM40

- (3) Align ring gear with parallel pin to put them into casing sub assy.
※ Be sure to maintain them vertical with ground while using press.



2209A8SM41

- (4) Screw 12 bolts (M16×45) to connect casing sub assy and ring gear (01) by using torque wrench.

Bolt (M16, 12EA) = 12.9T

The tightening torque = 27 ± 2.7 kgf·m
(195 ± 19.5 lbf·ft)

- ※ Apply enough loctite #242 before screwing bolts.



2209A8SM42

- (5) Use paint marker for checking surplus parts after assembling.



2209A8SM43



2209A8SM44

7) ASSEMBLING CARRIER SUB ASSY & SUN GEAR

- (1) Put No.2 carrier sub assy along spline of drive shaft spline.
- Screw M10 I-bolt to No.2 carrier sub assy.
 - Lifting up No.2 carrier sub assy and align planetary gear and tooth of ring gear by rotating planetary gear by hands.
 - Rotate No.2 carrier sub assy by hands to fit No.2 carrier sub assy into drive shaft spline.



2209A8SM45

- (2) Put No.2 sun gear into No.2 carrier sub assy.



2209A8SM46

- (3) Put No.1 carrier sub assy into No.2 sun gear along spline.
- Screw M10 I-bolt to No.1 carrier sub assy.
 - Lifting up No.1 carrier sub assy and align planetary gear and tooth of ring gear by rotating planetary gear by hands.
 - Rotate No.1 carrier sub assy by hands to fit No.1 carrier into No.2 sun gear spline.



2209A8SM47

- (4) Put No.1 sun gear into No.1 carrier sub assy. Be sure to maintain it vertical with ground. And align with No.1 planetary gear spline.
- (5) Rotate No.1 carrier sub assy by hands to check noise.



2209A8SM48

8) MEASURING CLEARANCE & ASSEMBLING NAME PLATE

- (1) Check the clearance between ring gear and No.1 sun gear using a tool with dial gauge.
- Check the clearance
Dial gauge = -0.3 ~ +2.95



2209A8SM49

GROUP 6 TRAVEL DEVICE

1. REMOVAL AND INSTALL

1) REMOVAL

- (1) Swing the work equipment 90° and lower it completely to the ground.
- (2) Operate the control levers and pedals several times to release the remaining pressure in the hydraulic piping.
- (3) Loosen the breather slowly to release the pressure inside the hydraulic tank.

▲ Escaping fluid under pressure can penetrate the skin causing serious injury.

※ When pipes and hoses are disconnected, the oil inside the piping will flow out, so catch it in oil pan.

- (4) Remove the track shoe assembly.
For details, see **removal of track shoe assembly**.
- (5) Remove the cover.
- (6) Remove the hose.
※ Fit blind plugs to the disconnected hoses.
- (7) Remove the bolts and the sprocket.
- (8) Sling travel device assembly (1).
- (9) Remove the mounting bolts (2), then remove the travel device assembly.
· Weight : 300 kg (660 lb)

2) INSTALL

- (1) Carry out installation in the reverse order to removal.
- (2) Bleed the air from the travel motor.
 - ① Remove the air vent plug.
 - ② Pour in hydraulic oil until it overflows from the port.
 - ③ Tighten plug lightly.
 - ④ Start the engine, run at low idling, and check oil come out from plug.
 - ⑤ Tighten plug fully.
- (3) Confirm the hydraulic oil level and check the hydraulic oil leak or not.



13031GE18

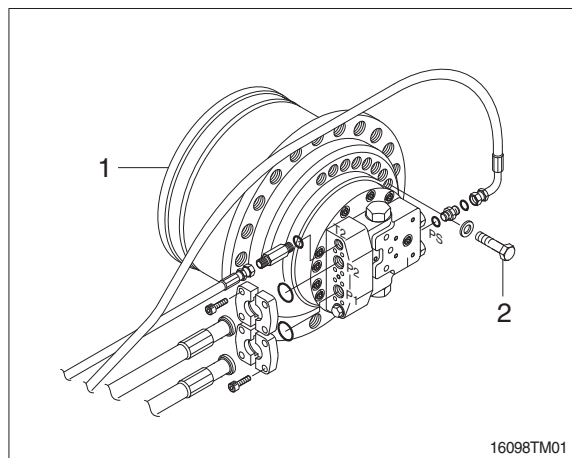

16098TM01

2. TRAVEL MOTOR

1) STRUCTURE

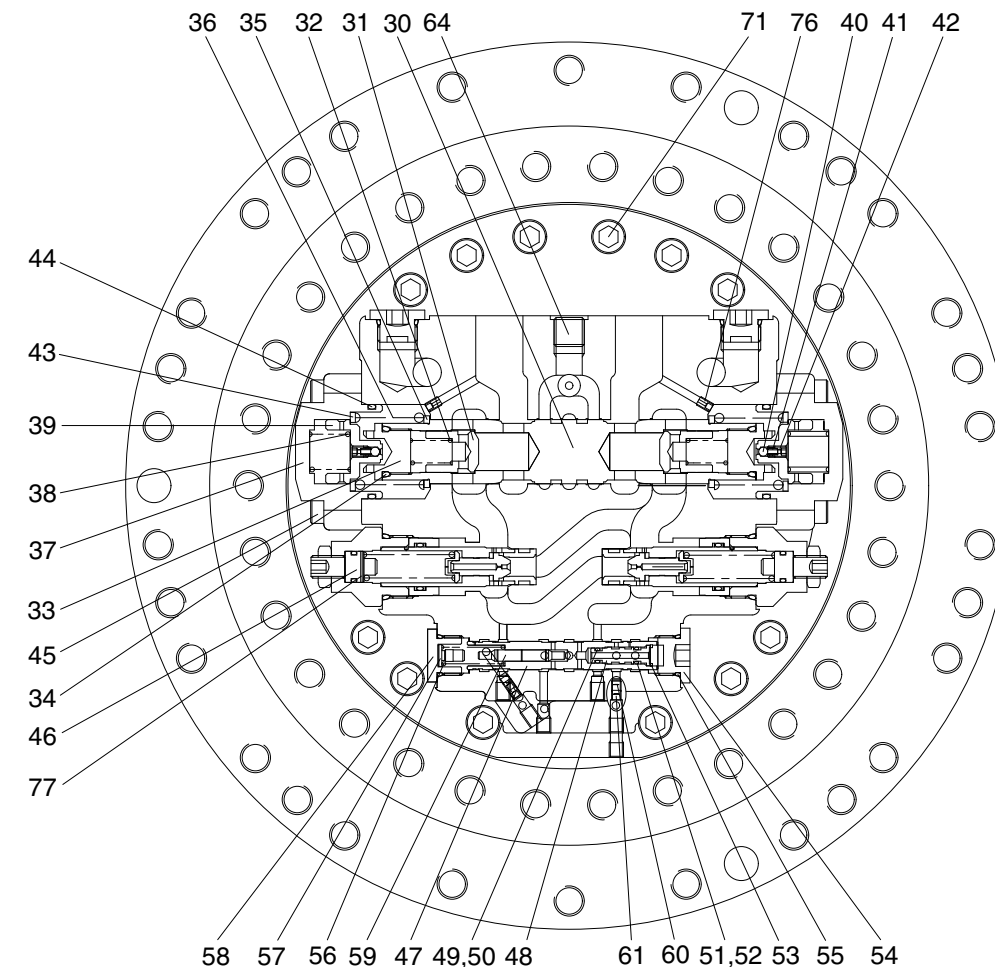
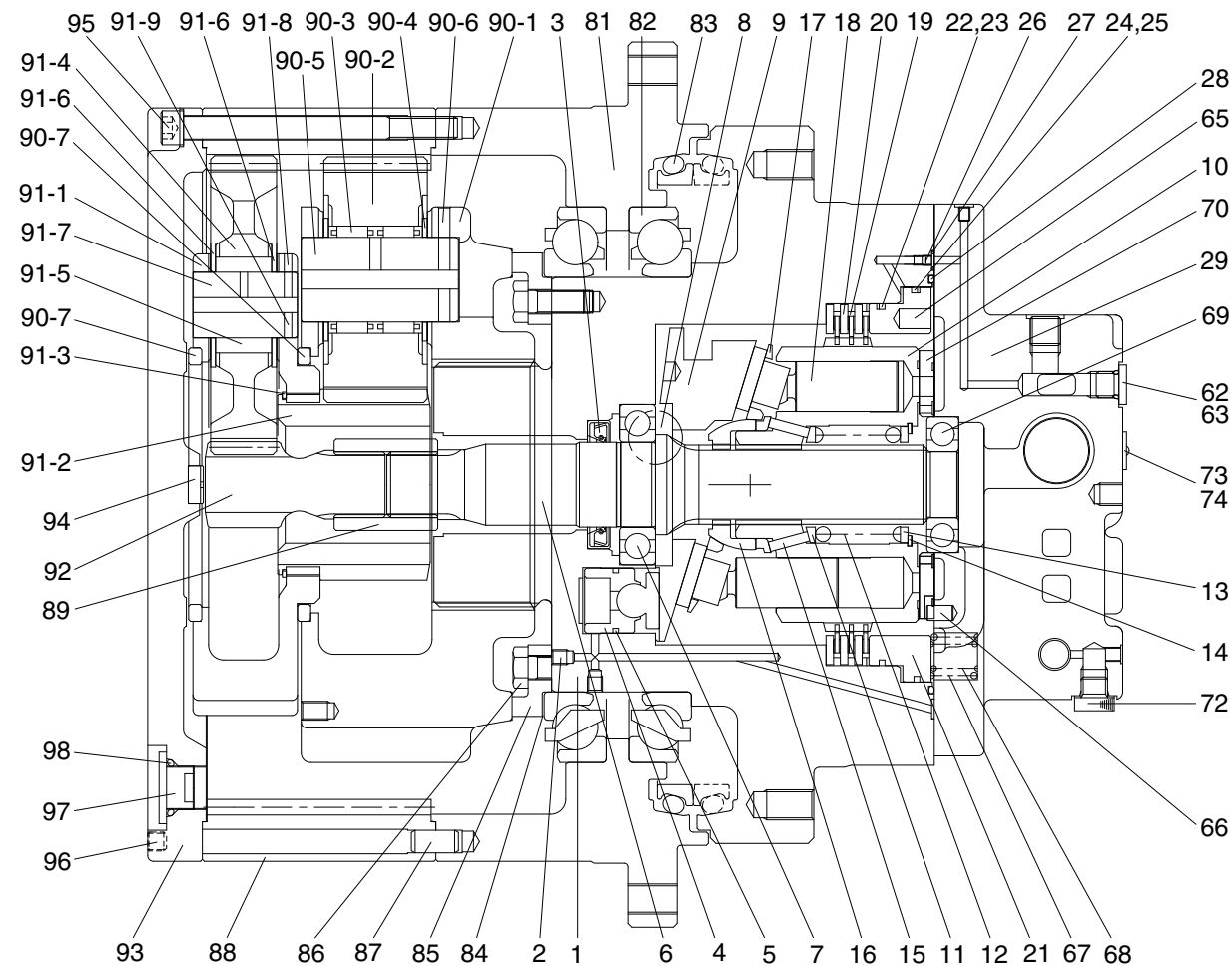

1 Shaft casing	20 Separate plate	39 Spool	58 Plug	77 Shim	91-1 Carrier No.1
2 Plug	21 Parking piston	40 Steel ball	59 Spool	81 Housing	91-2 Sun-gear No.2
3 Oil seal	22 O-ring	41 Spring	60 Orifice	82 Main bearing	91-3 Retaining ring
4 Swash piston	23 Back up ring	42 Plug	61 Orifice	83 Floating seal	91-4 Planetary gear No.1
5 Piston ring	24 O-ring	43 Spring seat	62 Plug	84 Shim	91-5 Needle bearing No.1
6 Shaft	25 Back up ring	44 O-ring	63 O-ring	85 Retainer	91-6 Thrust washer
7 Bearing	26 Orifice	45 Wrench bolt	64 Plug	86 Hex head bolt	91-7 Pin No.1
8 Steel ball	27 O-ring	46 Relief valve assy	65 Pin	87 Parallel pin	91-8 Spring pin
9 Swash plate	28 O-ring	47 Spool	66 Pin	88 Ring gear	91-9 Spring pin
10 Cylinder block	29 Rear cover	48 Guide	67 Spring	89 Coupling	92 Sun gear No.1
11 Spring seat	30 Spool	49 O-ring	68 Spring	90 Carrier assy No.2	93 Cover
12 Spring	31 Check	50 Back up ring	69 Bearing	90-1 Carrier No.2	94 Pad
13 End plate	32 Spring	51 O-ring	70 Valve plate	90-2 Planetary gear No.2	95 Hex socket head bolt
14 Snap ring	33 Plug	52 Back up ring	71 Wrench bolt	90-3 Needle bearing No.2	96 Hex socket Screw
15 Pin	34 O-ring	53 Snap ring	72 Plug	90-4 Thrust washer	97 Hydraulic plug
16 Ball guide	35 Spring seat	54 plug	73 Name plate	90-5 Pin No.2	98 O-ring
17 Set plate	36 Spring	55 O-ring	74 Rivet	90-6 Spring pin	99 Name plate
18 Piston assy	37 Cover	56 Spring	75 Seal kit	90-7 Thrust ring	
19 Friction plate	38 Spring	57 Spring seat	76 Orifice	91 Carrier assy No.1	

16092TM02

2) TOOLS AND TIGHTENING TORQUE

(1) Tools

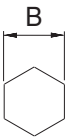
Tool name		Remark	
Allen wrench		2, 5, 4, 6, 10	
Socket for socket wrench, spanner	Socket	8, 14, 24, 27	
Torque wrench		Capable of tightening with the specified torques	
Pliers		-	
Plastic and iron hammer		Wooden hammer allowed. Normal 1 or so	
Monkey wrench		-	
Oil seal inserting jig		-	
Bearing pliers		-	
Seal tape		-	
Eye bolt		M10, M12, M14	
Press (0.5 ton)		-	
Oil stone		-	
Bearing assembling jig		-	

(2) Tightening torque

Part name	Item	Size	Torque	
			kgf · m	lbf · ft
Plug	2	NPT 1/16	1 ± 0.1	7.2 ± 0.7
Orifice	26	M5	0.7 ± 0.1	5 ± 0.7
Wrench bolt	45	M12 × 40	10 ± 1.0	72 ± 7.0
Relief valve	46	HEX 27	18 ± 1.0	130 ± 7.0
Plug	54	PF 1/2	8.5 ± 1.0	61 ± 7.0
Plug	58	HEX 24	5 ± 1.0	36 ± 7.0
Plug	62	PF 1/4	5 ± 1.0	36 ± 7.0
Wrench bolt	71	M12 × 35	10 ± 1.0	72 ± 7.0
Hex head bolt	-	M12 × 25	11 ± 1.5	79 ± 10
Hex socket head bolt	-	M12 × 155	11 ± 1.5	79 ± 10
Hex socket head plug	-	PF 3/4	19 ± 1	137 ± 7.0

3. OUTLINE OF DISASSEMBLING

1) GENERAL SUGGESTIONS

- (1) Select a clean place for dismantling.
Spread a rubber plate on a working table in order to prohibit the damage of parts.
- (2) Clean a deceleration equipment and a motor part, washing out dirt and unnecessary substances.
- (3) Without any damage of O-ring, oil seal, the adhered surface of other seals, a gear, a pin, the adhered surface of other bearings, and the surface of moisturized copper, treat each parts.
- (4) Numbers written in the parenthesis, (), next to the name of a part represent the part numbers of a cross-sectional view annexed with a drawing.
- (5) The side of a pipe in a motor can be written as a rear side; the side of out-put as a front side.
- (6) Using and combining a liquid gasket, both sides must be dried completely before spraying a liquid gasket.
- (7) In case of bonding bolts, combine a standard torque by torque wrench after spraying loctite 262 on the tab parts. (It can be dealt as assembling NPTF screws and an acceleration equipment.)

3.1 DISASSEMBLING

- 1) Unloosing wrench bolt and disassemble cover (37).
※ Wrench bolt = M12 × 40L-8 EA
(purchasing goods)

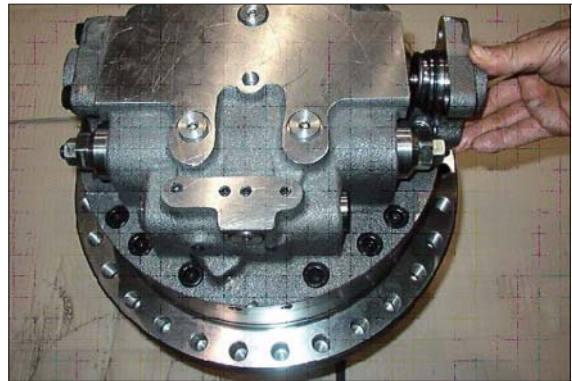

21078TM21

- 2) Disassemble parts related to counterbalance valve.



21078TM22

- 3) Unloosing wrench bolt (M12×35L, 16 EA) and disassemble rear cover assembly from motor assembly.

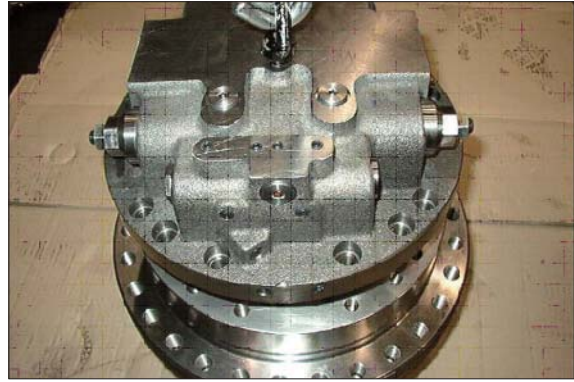

21078TM23



21078TM24

- 4) Dismantle packing piston (21) using compressed air.



21078TM25

- 5) Disassembly rotary kit from motor assembly (cylinder block assembly, piston assembly, ball guide, set plate, friction plate, steel plate...)

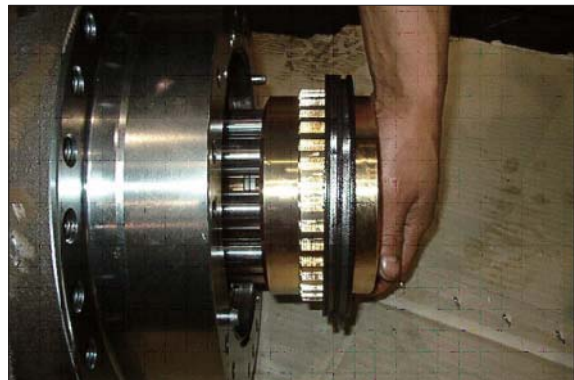

21078TM26

6) Using a jig, disassemble swash plate (9) from shaft casing.



21078TM27

7) Using compressed air, disassemble piston swash (4) piston ring (5), respectively.



21078TM28



21078TM29

8) Using a hammer, disassemble shaft (6) from shaft casing (1).

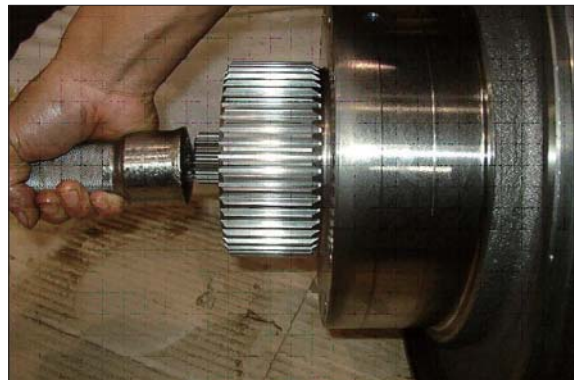

21078TM30

■ Disassemble cylinder sub.

9) Disassemble cylinder block assembly, piston assembly (9) and seat plate (M).

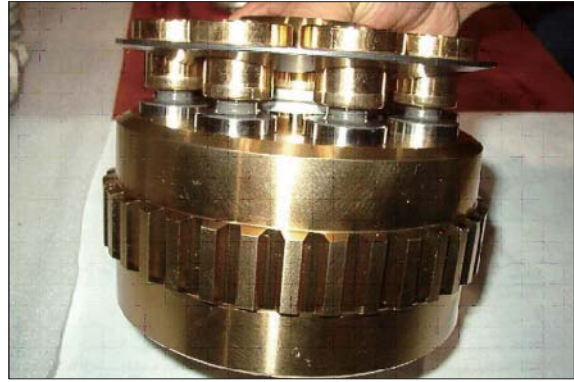

21078TM31



21078TM32

10) Disassemble ball guide (16), ring and pin (15) from cylinder block, respectively.



21078TM33



21078TM34



21078TM35

- 11) Pushing spring (12) by an assembling jig, disassemble snap ring (14), spring seat (13), spring (12) and spring seat (11), respectively.

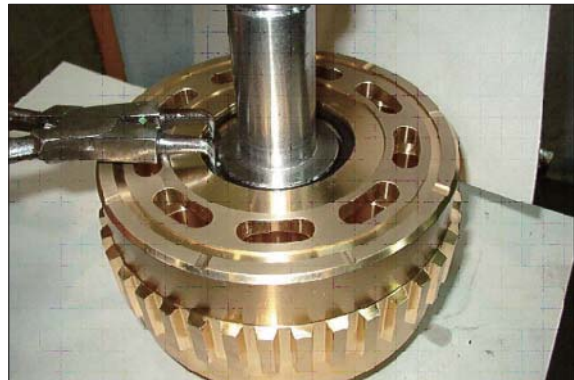

21078TM36



21078TM37

■ **Disassemble valve casing sub.**

- 12) Using an hexagon wrench, unloosing wrench bolt (45) and disassemble cover (37), spring (38), spool (39), spring seat (43), spring (36) and spring seat (35), respectively.
(same balance on both sides)

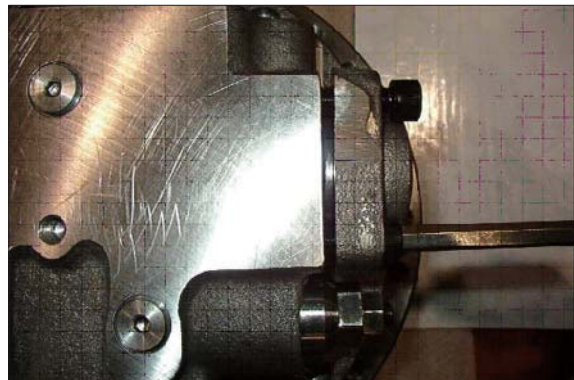

21078TM38



21078TM39

13) Disassemble spool (59), spool (47), O-ring (51), guide (48) and snap ring (53) on rear cover, respectively.

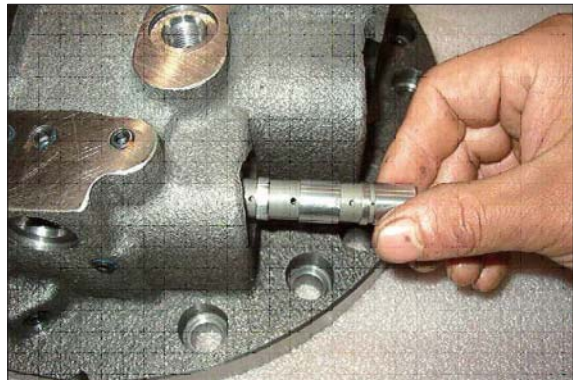

21078TM40



21078TM41

14) Using a torque wrench, disassemble relief valve assembly (46) on rear cover.



21078TM42

4. OUTLINE FOR ASSEMBLING

1) GENERAL SUGGESTIONS

- (1) After washing each parts cleanly, dry it with compressed air.
Provided that you do not wash friction plate with treated oil.
- (2) In bonding each part, fasten bond torque.
- (3) When using a hammer, do not forget to use a plastic hammer.

4.1 ASSEMBLING

■ Assemble the sub of turning axis

- 1) Using a jig, assemble oil seal (3) into shaft casing (1)



21078TM43

- 2) Have a bearing (8) thermal reacted into shaft (6).



21078TM44



21078TM45



21078TM46

- 3) Using a jig, assemble shaft assembly into shaft casing (1).



21078TM47

- 4) After spreading grease on steel ball (8) assemble into shaft casing (1).



21078TM48

- 5) Assemble swash piston assembly (4, 5) into shaft casing (1).



21078TM49

- 6) Assemble swash plate (9) into shaft casing (1).

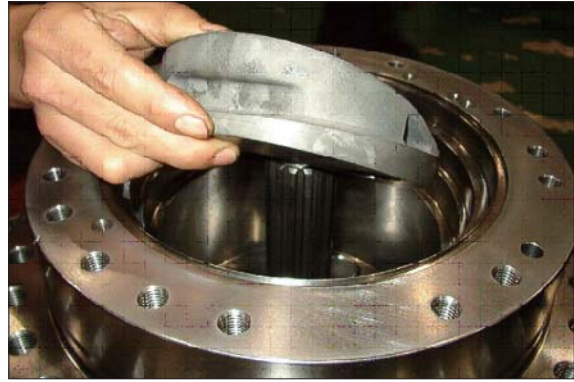

21078TM50

■ Assemble cylinder block sub.

- 7) Assemble spring seat (13), spring (12), spring seat (11) into cylinder block (10) respectively, pushing spring (12) using by a jig, assemble snap ring (14) with a snap ring (14).



21078TM51

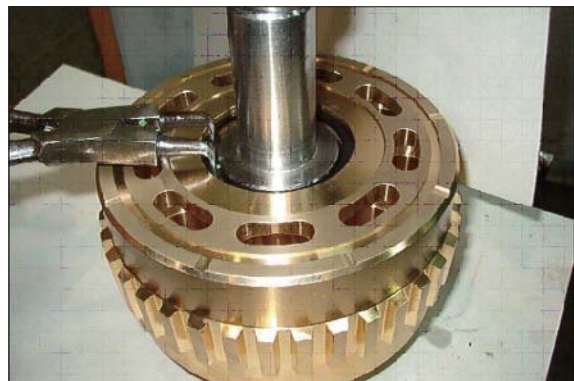

21078TM52

8) Assemble ring, pin (15) on cylinder block (10) ball guide (16) respectively.



21078TM53



21078TM54



21078TM55

9) Assemble cylinder block assembly, piston assembly (9), seat plate (17).



21078TM56

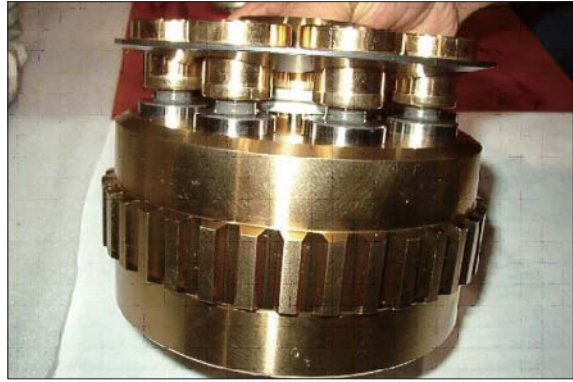

21078TM57

10) Assemble cylinder block assembly (9) into shaft casing (1).

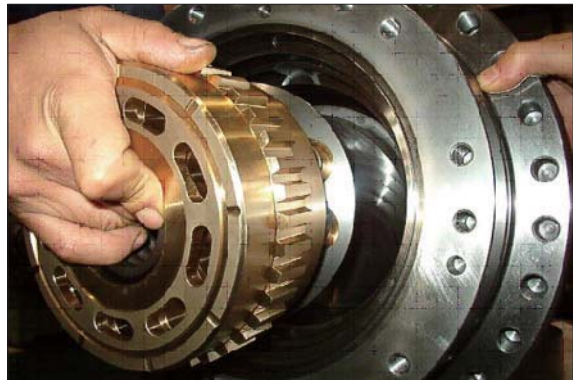

21078TM58

11) Assemble friction plate (19) and plate (20) into shaft casing (1) respectively, prepare 6 set.



21078TM59



21078TM59-1

12) Assemble O-ring (22, 23) into packing piston (21).



21078TM60

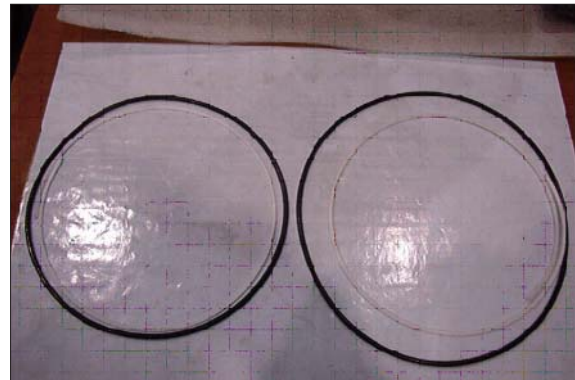

21078TM60-1

13) After spreading grease on packing piston (21) bond wrench bolt and assemble shaft casing (1).



21078TM61

■ Assemble rear cover sub.

14) Using a jig, assemble bearing (69) into rear cover (29).



21078TM62

- 15) After assembling spool (59), spool (47), O-ring (51), guide (48) and snap ring (53) respectively into rear cover (29).
Using torque wrench, assemble it.



21078TM63

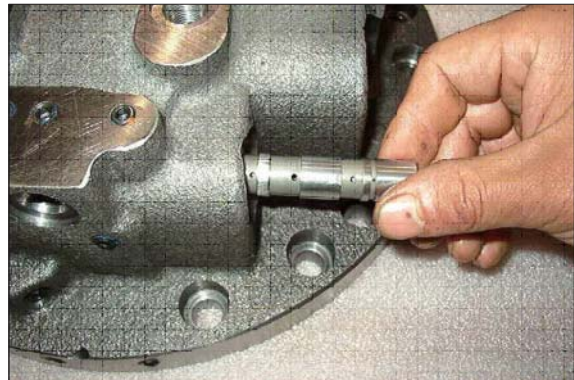

21078TM64

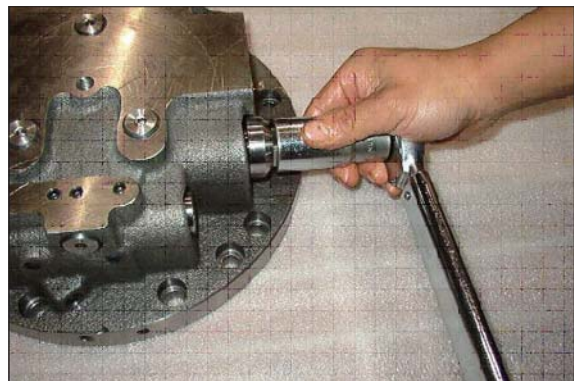

21078TM65

16) Assemble spring seat (35), spring (36), spring seat (43), spool (39), spring (38), cover (37) respectively and assemble wrench bolt (45).
(same balance on both sides)

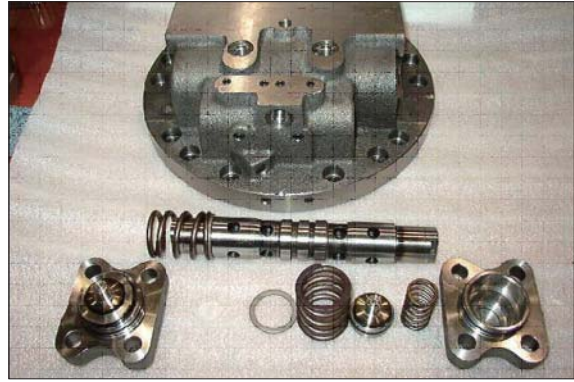

21078TM66

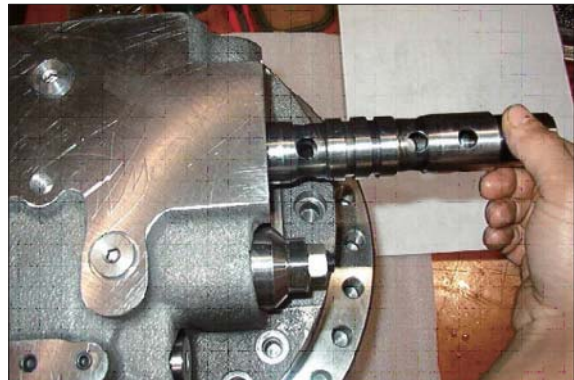

21078TM67

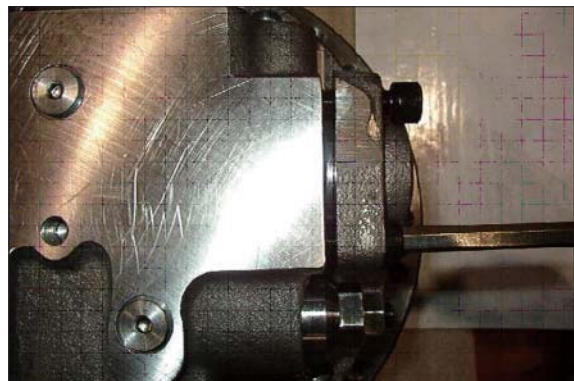

21078TM67-1

17) Assemble plug (2).

※ Plug (NPT1/16) - 11 EA



21078TM68



21078TM69

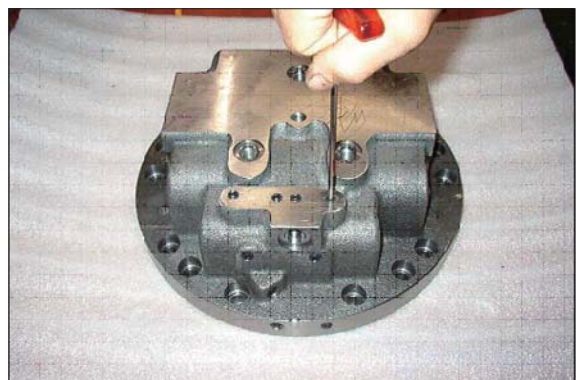

21078TM70



21078TM71

18) Assemble plug (64).

※ Plug (PT3/8) - 11 EA

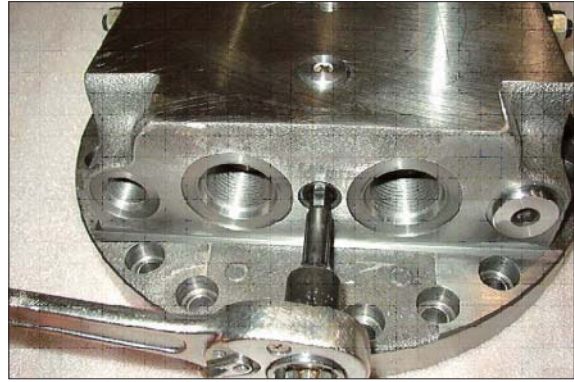

21078TM72

19) Assemble plug (62, 63) into rear cover (29) and assemble relief valve assembly.

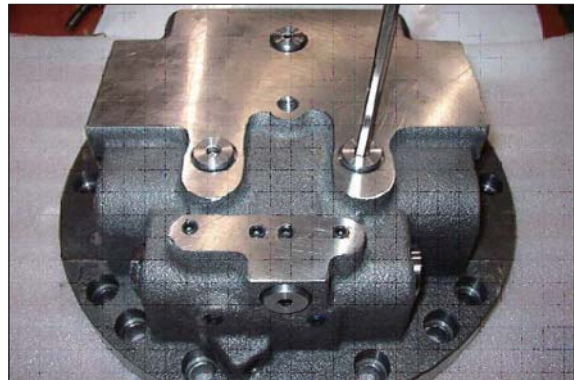

21078TM73

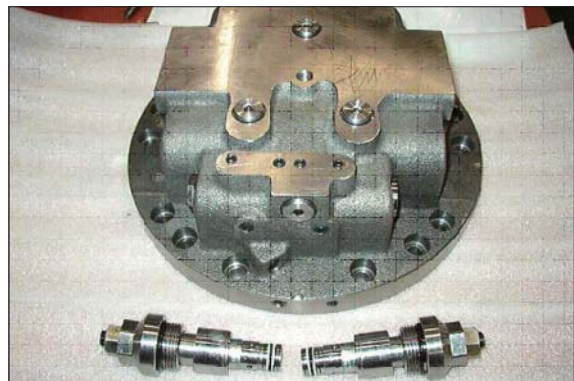

21078TM74

20) Put spring (67, 68) together into rear cover (29), prepare 6 set.



21078TM75



21078TM76

21) Assemble valve plate (70) into rear cover (29).



21078TM77

22) After assembling shaft casing (1) and rear cover (29).
Assemble spool assembly (30), spring (38),
spool (39), cover (37) after then complete
assembly with wrench bolt (45).

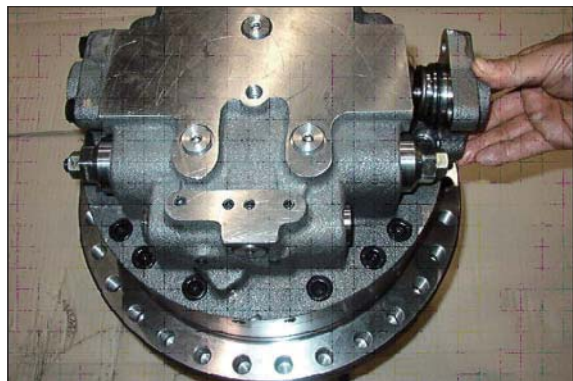

21078TM78

23) Finish assembly.

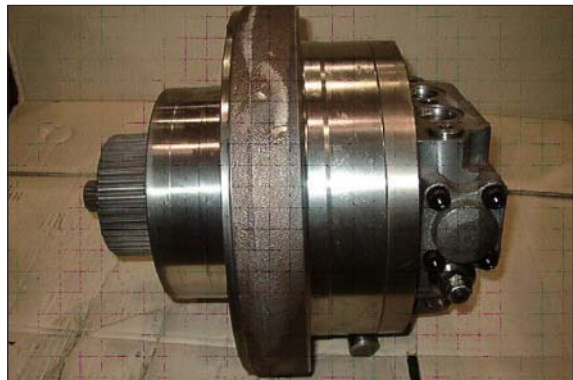

21078TM79

5.1 DISASSEMBLING REDUCTION UNIT

1) Preparation for disassembling

- (1) The reduction units removed from excavator are usually covered with mud. Wash outside of propelling unit and dry it.
- (2) Locate reducer in order for drain port to be at the lowest level loosen taper screw plug of drain port, and drain oil from reduction gear.
 - ※ While oil is still hot, inside of the unit may be pressurized.

▲ Take care of the hot oil gushing out of the unit when loosening the plug.

(3) Mark for mating

Put marks on each mating parts when disassembling so as to reassemble correctly as before.

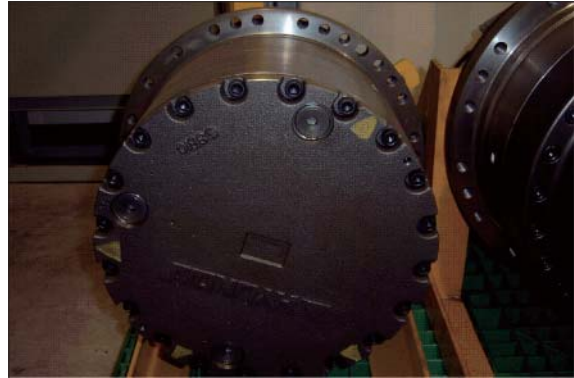

21078TM80

2) Setting reduction unit (or whole propelling unit) on work stand for disassembling

- (1) Remove M12 hexagon socket head bolts (95) at 3 places from cover (93) almost equally apart each other, and then install M12 × 155L eye bolts. Lift up the unit using them and place it on work stand with cover upward.

▲ Take great care not to pinch your hand between parts while disassembling nor let fall parts on your foot while lifting them.



21078TM81

3) Removing cover

- (1) Remove the rest of M12 hexagon socket head bolts (95) that securing gear and housing. Loosen all the socket bolts and then, disassemble cover.
- (2) As the cover (93) is adhered to ring gear (88), disassemble ring gear (88) and cover (93) by lightly hammering slantwise upward using sharpen punch inserted between the cover and ring gear.

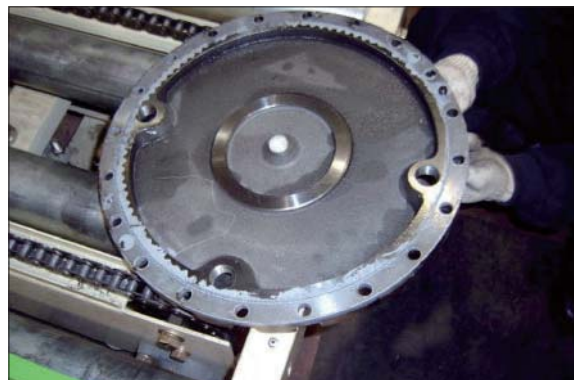

21078TM82

4) Removing No.1 carrier sub assembly

- (1) Screw three M10 eye-bolt in No.1 carrier and lift up and remove No.1 carrier assy.



21078TM83

- (2) Remove No.1 sun gear

- ※ Be sure to maintain it vertical with the ground when disassembling No.1 sun gear.



21078TM84

5) Removing No.2 carrier sub assembly

- (1) Screw three M10 eye-bolt in No.2 carrier and lift up and remove No.2 carrier assy.



21078TM85

- (2) Remove No.2 sun gear

- ※ Be sure to maintain it vertical with the ground when disassembling No.2 sun gear.

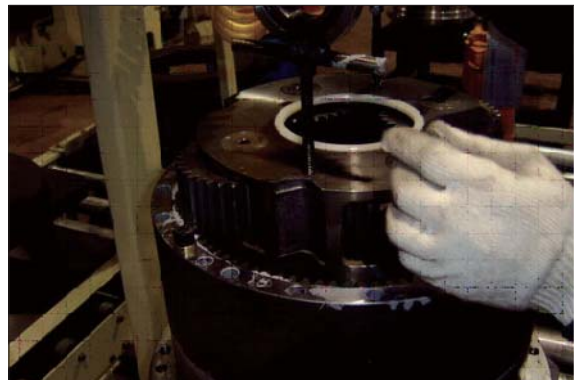

21078TM86

6) Removing ring gear

- (1) As the ring gear (88) is adhered to housing (81), disassemble ring gear (88) and housing (81) by lightly hammering slantwise upward using sharpen punch inserted between the ring gear and housing.
 - ※ Carefully disassembling ring gear not to make scratch on it.
- (2) Screw M14 eye-bolt in ring gear and lift up and remove it.

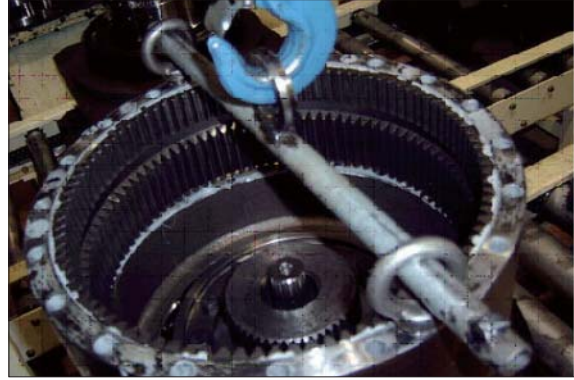

21078TM87

7) Removing coupling

- (1) Remove coupling.

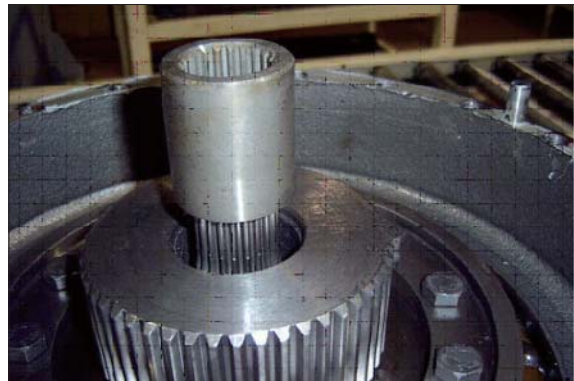

21078TM88

8) Removing retainer & shim

- (1) Remove M12 hexagon socket head bolts that secure retainer and motor.
- (2) Remove retainer & shim.

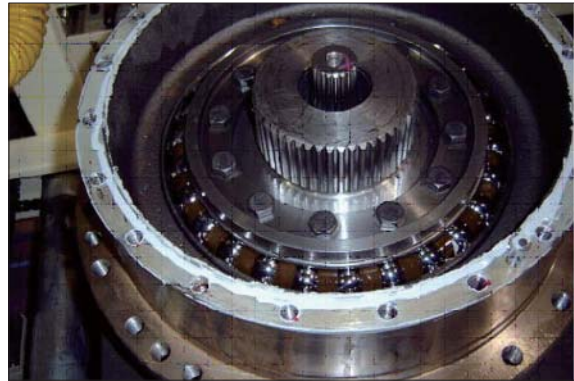

21078TM89

9) Removing housing sub assembly

- (1) Screw M12 eye bolt in housing and lift up housing assembly including angular bearing and floating seal.



21078TM90

10) Removing floating seal

- (1) Lift up a piece of floating seal of motor side.



21078TM91

11) Disassembling housing assembly

- (1) After turning housing, lift up a piece of floating seal from housing and then remove it.
- ※ Don't disassemble angular bearing.

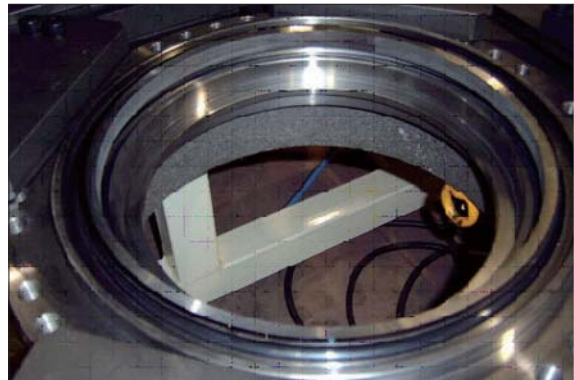

21078TM92

12) Disassembling No.1 carrier

- (1) Remove thrust ring (90-7) from carrier.
- (2) Knock spring pin (91-8) fully into No.1 pin (91-7).
- (3) Remove planetary, thrust washer, No.1 pin, bearing from carrier.



21078TM93



21078TM94



21078TM95

13) Disassembling No.2 carrier

- (1) Disassemble No.2 carriers, using the same method for No.1 carrier assembly.



21078TM96



21078TM97

6.1 ASSEMBLY REDUCTION GEAR

■ General notes

Clean every part by kerosene and dry them by air blow.

Surfaces to be applied by locktite must be decreased by solvent.

Check every part for any abnormalities.

Each hexagon socket head bolt should be used with locktite No.

262 applied on its threads.

Apply gear oil slightly on each part before assembling.

Take great care not to pinch your hand between parts or tools while assembling nor let fall parts on your foot while lifting them.

Inspection before reassembling

Thrust washer

- Check if there are seizure, abnormal wear or uneven wear.
- Check if wear is over the allowable limit.

Gears

- Check if there are pitting or seizure on the tooth surface.
- Check if there are cracks on the root of tooth by die check.

Bearings

- Rotate by hand to see if there are something unusual such as noise or uneven rotation.

Floating seal

- Check flaw or score on sliding surfaces or O-ring.



21078TM98

1) Assembling No.1 carrier

- (1) Put No.1 carrier (91-1) on a flat place.
- (2) Install No.1 needle bearing (91-5) into No.1 planetary gear (91-4), put 2 EA of No.1 thrust washer (91-6) on both sides of bearing, and then, install it into carrier.



21078TM99

- (3) Install No.1 pin (91-5) into No.1 carrier where the holes for No.1 pin (91-5) are to be in line with those of No.1 carrier, and then, install spring pins into the holes.



21078TM100

- (4) Caulk carrier holes as shown on the picture.
 (5) Assembly thrust ring (90-7) into carrier.



21078TM101

2) Assembling No.2 carrier

- (1) Put No.2 carrier (90-1) on a flat place.
 (2) Install No.2 needle bearing (90-3) into No.2 planetary gear (90-2), put 2 EA of No.2 thrust washer (90-4) on both sides of bearing, and then, install it into carrier.

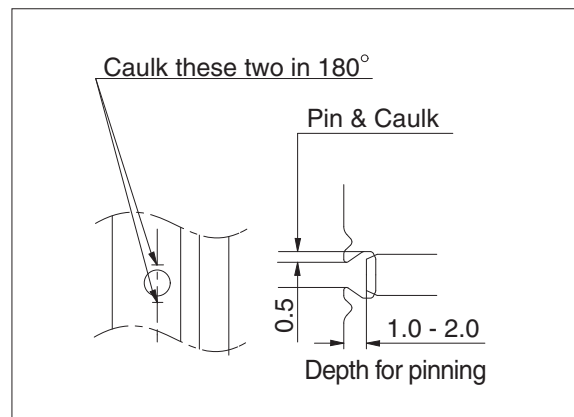

21078TM102

- (3) Install No.2 pin (90-5) into No.2 carrier where the holes for No.2 pin (90-5) are to be in line with those of No.2 carrier, and then, install spring pins into the holes.



21078TM103

- (4) Caulk carrier holes as shown on the picture.
- (5) Assemble thrust ring (90-7) into carrier.

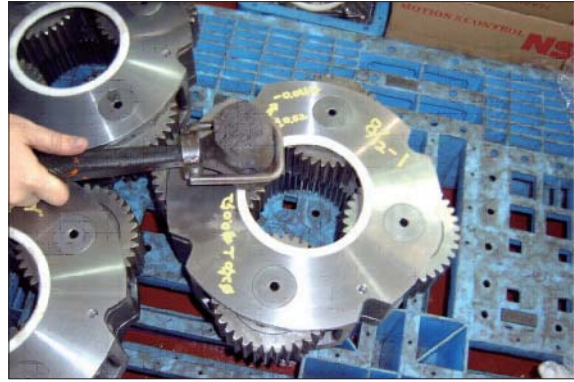

21078TM104

3) Assembling floating seal (83) and main bearing (82)

- (1) Assemble floating seal into motor by use of pressing jig. Grease the contact parts for floating seal which is assembled into motor.
- (2) Heat bearing at 60~70°C and then, put into the motor side.



21078TM105

- ※ Be sure to maintain it vertical with the ground when assembling bearing and floating seal.



21078TM106

4) Assembling housing

- (1) Heat housing at 60~70°C while clearing it out and then, assemble floating seal into housing by use of pressing jig.
- ※ Be sure to maintain it vertical with the ground when assembling floating seal.

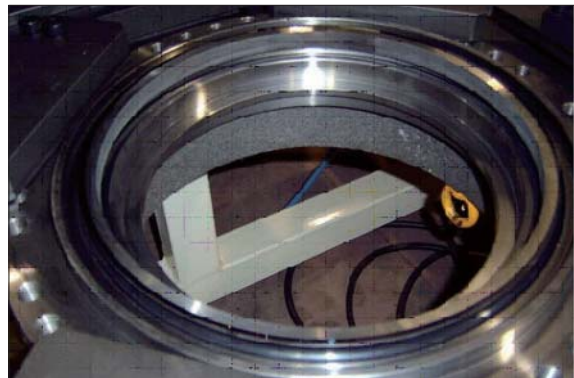

21078TM705

5) Installing housing assembly

- (1) Install 2 EA of M12 eye-bolt into housing assembly.
 - (2) Assemble housing into motor by use of hoist and eye-bolt.
- ※ Be sure to tighten eye-bolt deep enough.



21078TM108

6) Installing main bearing (82)

- (1) Heat main bearing at 60~70° C and then, install.
- ※ Be sure to maintain it vertical with the ground when assembling bearing.



21078TM109

7) Installing retainer (85) and shim (84)

- (1) Measure clearance between main bearing and retainer by use of jig to decide the thickness of shim and select an appropriate shim, and then, assemble retainer.
- (2) Apply locktite (#262) on M12 hexagon head bolt, and then, bolt.

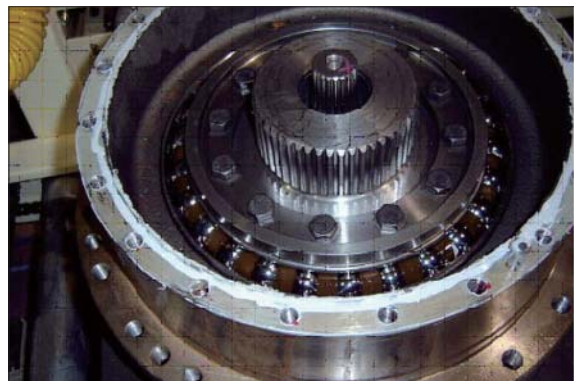

21078TM110

8) Installing coupling

- (1) Install coupling on spline of the motor.

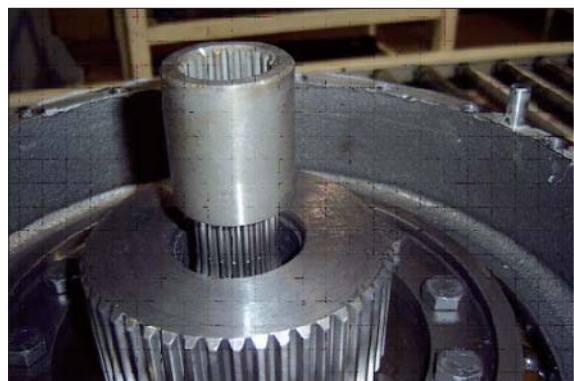

21078TM111

9) Installing ring gear

- (1) Apply three bond #1104 (loctite #515) on housing for ring gear without gap.
- (2) Insert lock pin into housing hole.
- (3) Install M14 eye-bolt on the tap of ring gear.
- (4) Lift ring gear and then, assemble into housing in order for hole of ring gear and parallel pin of housing to be in line.
- (5) Temporarily secure 4EA of M12 hexagon socket bolt and shim with cover thickness having appropriate torque.

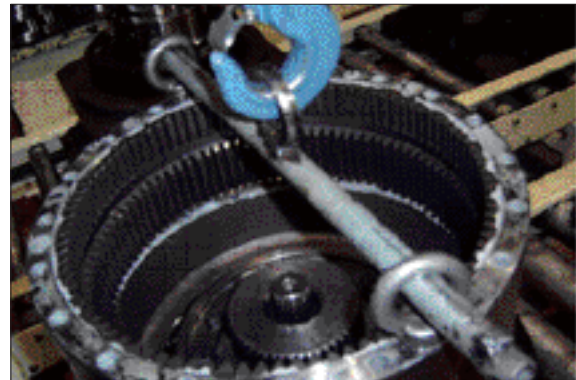
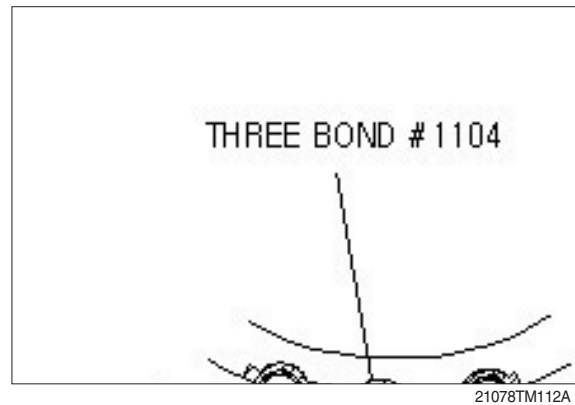

10) Installing No.2 carrier sub assembly

- (1) Install M10 eye-bolt on No.2 carrier assembly.
- (2) Lift No.2 carrier assembly and then, slowly put it down on ring gear.
- (3) Rotate planetary gear by hands and install on ring gear.

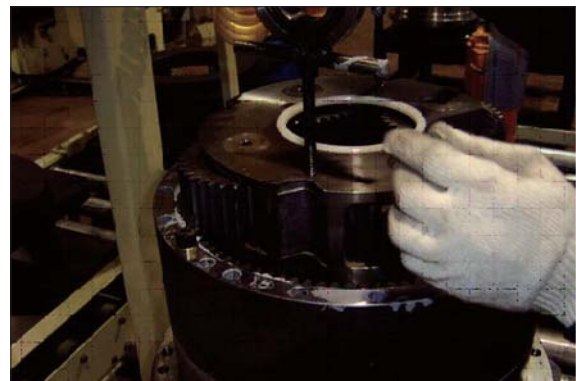

11) Installing No.2 sun gear (91-2)

- (1) Install No.2 sun gear on the spline of No.2 carrier and No.2 planetary gear, matching teeth of them.



21078TM115

- (2) Install No.2 sun gear on the spline of No.2 carrier and No.2 planetary gear, matching teeth of them.

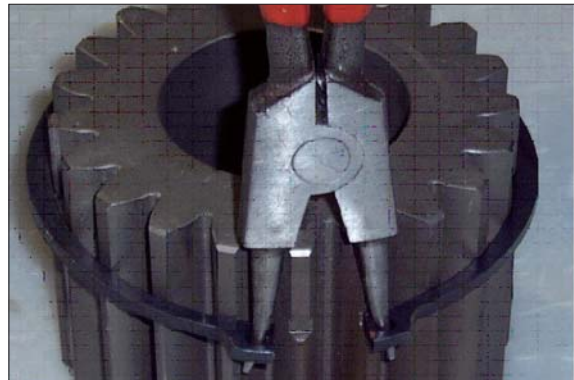

21078TM116

12) Installing No.1 carrier sub assembly

- (1) Install M10 eye-bolt on No.2 carrier assembly.
- (2) Lift No.1 carrier assembly and then, slowly put it down on ring gear.
- (3) Rotate planetary gear by hands and install on ring gear.



21078TM117

13) Installing No.1 sun gear (92)

- (1) Put down No.1 sun gear on No.1 carrier, maintaining it vertical with spline of coupling.
- (2) Install No.1 sun gear on No.1 planetary gear, matching their teeth.



21078TM118

14) Installing cover (93)

- (1) Beat pad (94) with plastic hammer, and press it into the center of cover.
- (2) Apply three bond #1104, loctite (#515) on the ring gear for cover without gap.
- (3) Put cover on ring gear, apply loctite (#262) on M12 hexagon socket head bolt, and then, bolt.

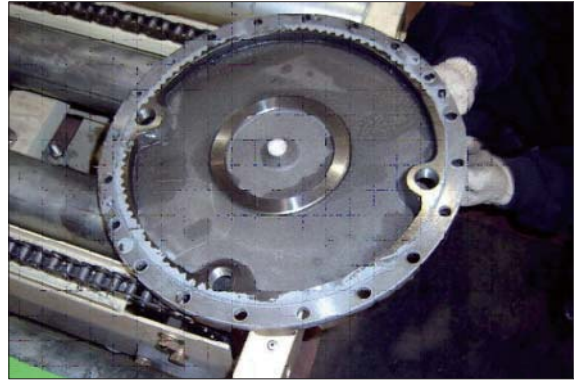

21078TM119

- (4) Fill gear oil (5.8 liter) into drain port.
- (5) Apply gear oil on PF3/4 hydraulic plug (97) and then, bolt.



21078TM120

GROUP 7 RCV LEVER

1. REMOVAL AND INSTALL

1) REMOVAL

- (1) Lower the work equipment to the ground and stop the engine.
- (2) Operate the control levers and pedals several times to release the remaining pressure in the hydraulic piping.
- (3) Loosen the breather slowly to release the pressure inside the hydraulic tank.

▲ Escaping fluid under pressure can penetrate the skin causing serious injury.

- (4) Loosen the socket bolt (1).
 - (5) Remove the cover of the console box.
 - (6) Disconnect pilot line hoses (3).
 - (7) Remove the pilot valve assembly (2).
- ※ When removing the pilot valve assembly, check that all the hoses have been disconnected.

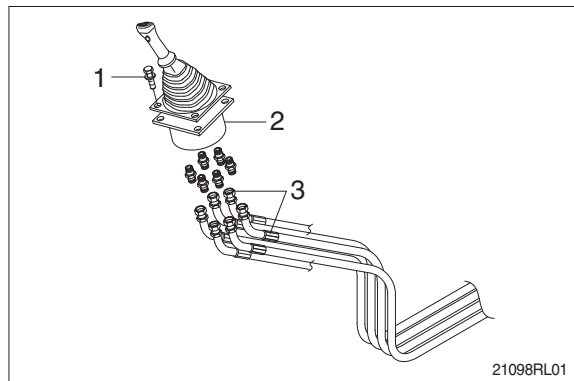

2) INSTALL

- (1) Carry out installation in the reverse order to removal.
- (2) Confirm the hydraulic oil level and check the hydraulic oil leak or not.

2. DISASSEMBLY AND ASSEMBLY

1) STRUCTURE

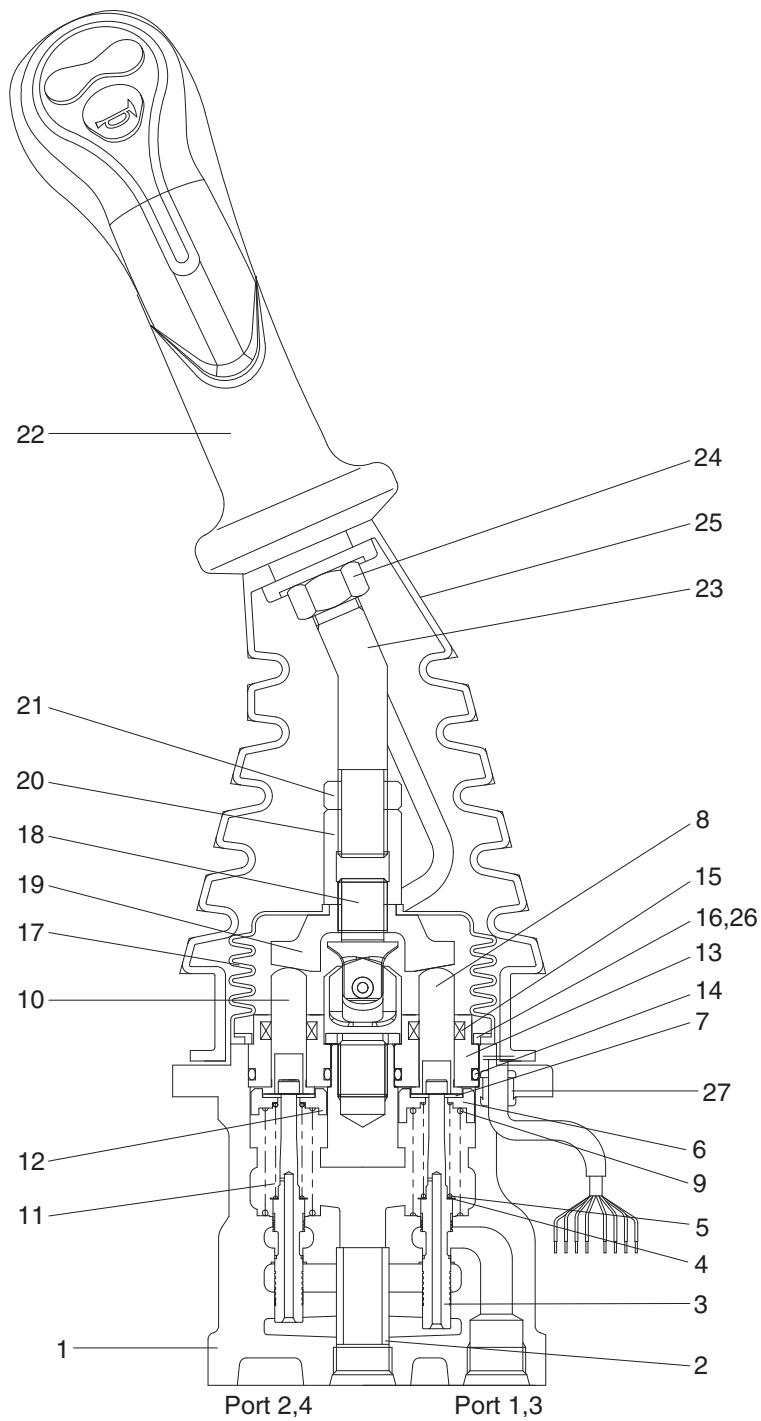

1409S2RL02

1	Case	8	Push rod	15	Rod seal	22	Handle assembly
2	Bushing	9	Spring	16	Plate	23	Handle bar
3	Spool	10	Push rod	17	Boot	24	Nut
4	Shim	11	Spring	18	Joint assembly	25	Boot
5	Spring	12	Spring seat	19	Swash plate	26	Spring pin
6	Spring seat	13	Plug	20	Adjusting nut	27	Bushing
7	Stopper	14	O-ring	21	Lock nut		

2) TOOLS AND TIGHTENING TORQUE

(1) Tools

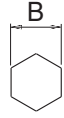
Tool name	Remark	
Allen wrench	6	
Spanner	22	
	27	
(+) Driver	Length 150	
(-) Driver	Width 4~5	
Torque wrench	Capable of tightening with the specified torques	

(2) Tightening torque

Part name	Item	Size	Torque	
			kgf · m	lbf · ft
Joint	18	M14	3.5	25.3
Swash plate	19	M14	5.0±0.35	36.2±2.5
Adjusting nut	20	M14	5.0±0.35	36.2±2.5
Lock nut	21	M14	5.0±0.35	36.2±2.5

3) DISASSEMBLY

- (1) Clean pilot valve with kerosene.
 - ※ Put blind plugs into all ports
- (2) Fix pilot valve in a vise with copper (or lead) sheets.
- (3) Remove end of boot (25) from case (1) and take it out upwards.

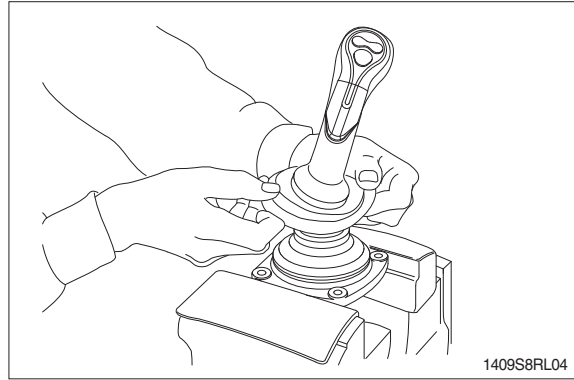

- ※ For valve with switch, remove cord also through hole of casing.

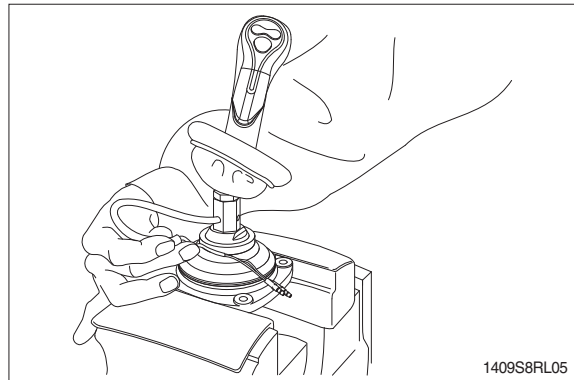

- (4) Loosen lock nut (21) and adjusting nut (20) with spanners on them respectively, and take out handle section as one body.

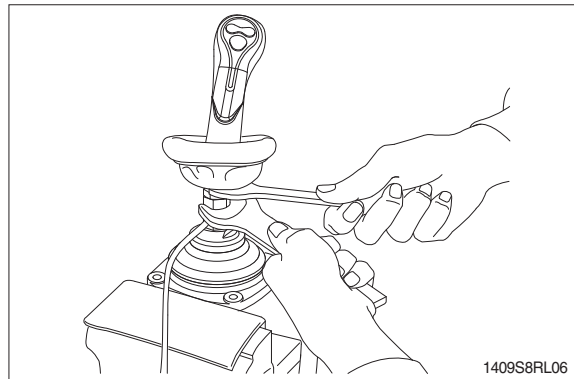

- (5) Remove the boot (17).

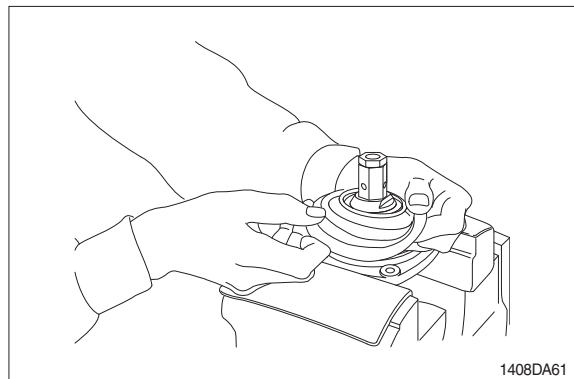

- (6) Loosen adjusting nut (20) and swash plate (19) with spanners on them respectively, and remove them.

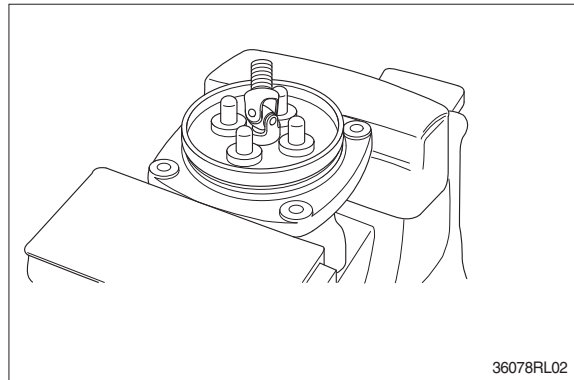
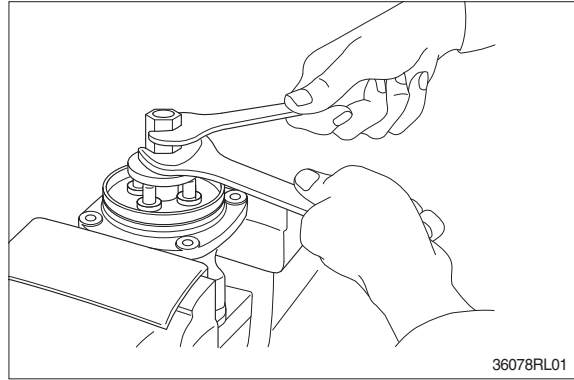

- (7) Turn joint anticlockwise to loosen it, utilizing jig (special tool).

- ※ When return spring (9) is strong in force, plate (16), plug (13) and push rod (10) will come up on loosening joint. Pay attention to this.

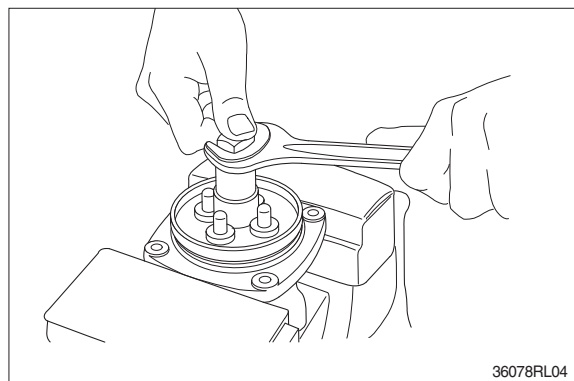
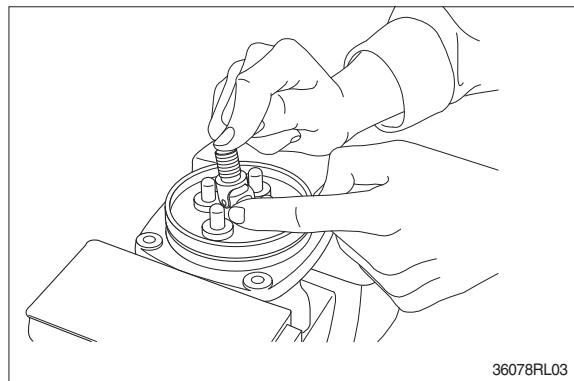

(8) Remove plate (16).

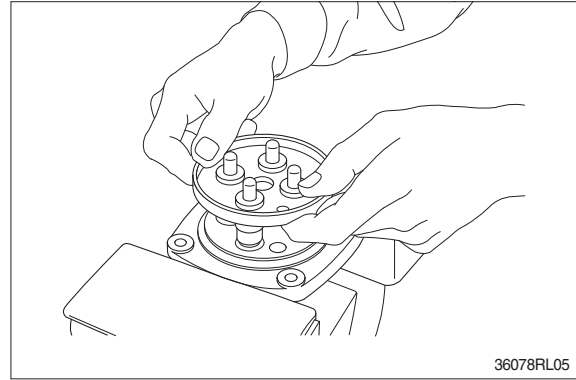

(9) When return spring (9) is weak in force, plug (13) stays in casing because of sliding resistance of O-ring.

※ Take it out with minus screwdriver.

Take it out, utilizing external periphery groove of plug and paying attention not to damage it by partial loading.

※ During taking out, plug may jump up due to return spring (9) force.

Pay attention to this.

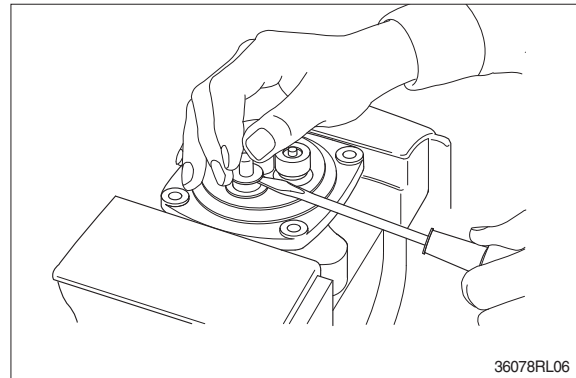

(10) Remove reducing valve subassembly and return spring (9) out of casing.

※ Record relative position of reducing valve subassembly and return springs.

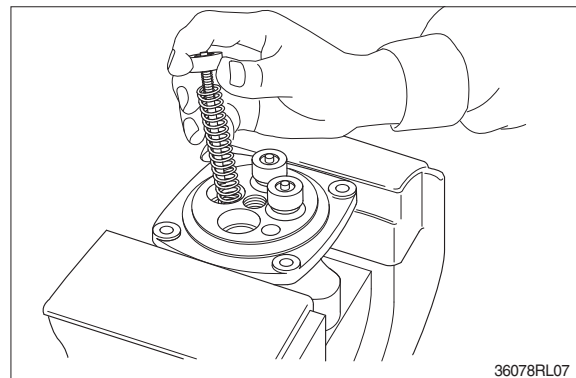

(11) For disassembling reducing valve section, stand it vertically with spool (3) bottom placed on flat workbench. Push down spring seat (6) and remove two pieces of semicircular stopper (7) with tip of small minus screwdriver.

※ Pay attention not to damage spool surface.

※ Record original position of spring seat (6).

※ Do not push down spring seat more than 6mm.

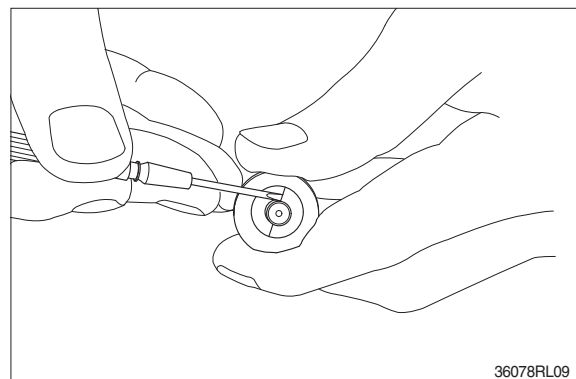

- (12) Separate spool (3), spring seat (6), spring (5) and shim (5) individually.
※ Until being assembled, they should be handled as one subassembly group.

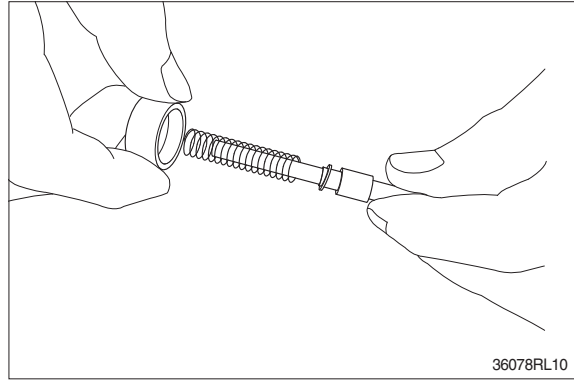

- (13) Take push rod (10) out of plug (13).

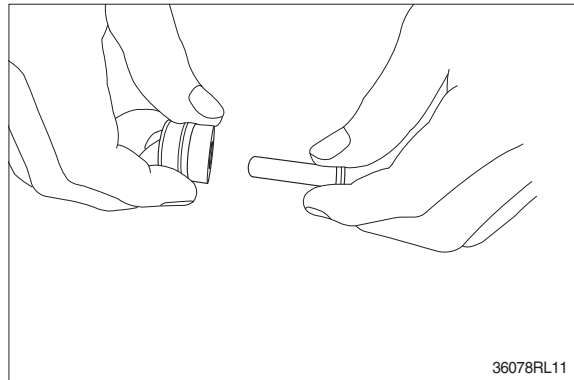

- (14) Remove O-ring (14) and seal (15) from plug (13).
Use small minus screwdriver or so on to remove this seal.

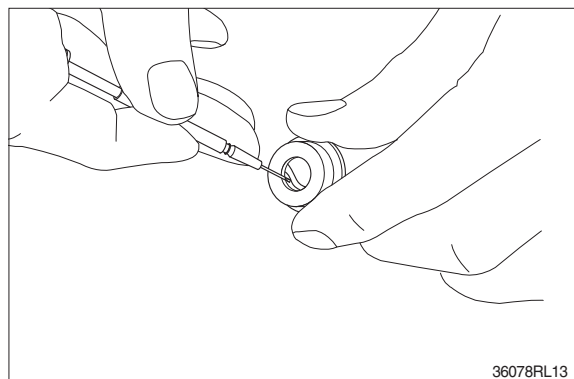
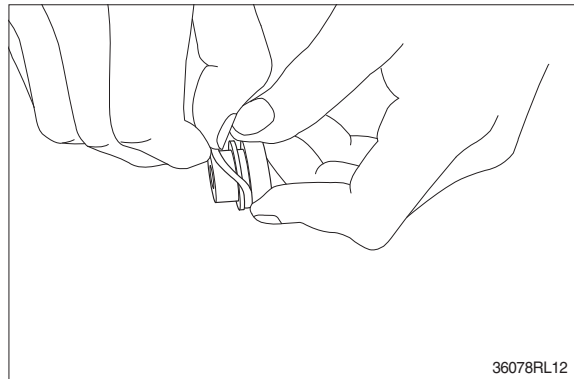

(15) Remove lock nut (21) and then boot (25).

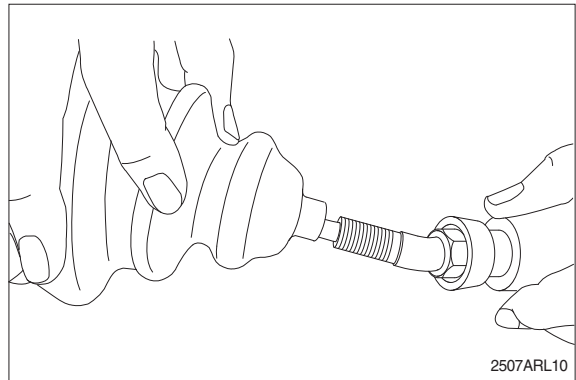
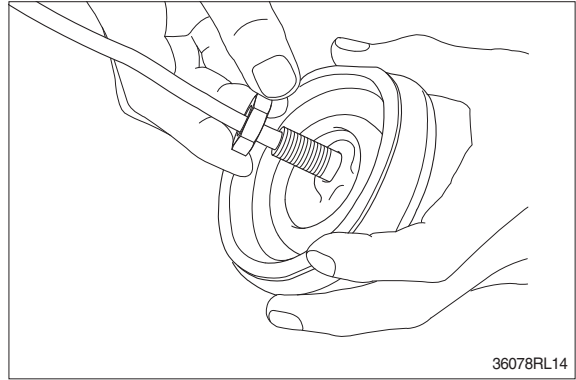

(16) Cleaning of parts

- ① Put all parts in rough cleaning vessel filled with kerosene and clean them (rough cleaning).
 - ※ If dirty part is cleaned with kerosene just after putting it in vessel, it may be damaged. Leave it in kerosene for a while to loosen dust and dirty oil.
 - ※ If this kerosene is polluted, parts will be damaged and functions of reassembled valve will be degraded.
Therefore, control cleanliness of kerosene fully.
- ② Put parts in final cleaning vessel filled with kerosene, turning it slowly to clean them even to their insides (finish cleaning).
 - ※ Do not dry parts with compressed air, since they will be damaged and/or rusted by dust and moisture in air.

(17) Rust prevention of parts

- Apply rust-preventives to all parts.
- ※ If left as they are after being cleaned, they will be rusted and will not display their functions fully after being reassembled.

4) ASSEMBLY

- (1) Put shim (4), springs (5) and spring seat (6) onto spool (3) in this order.

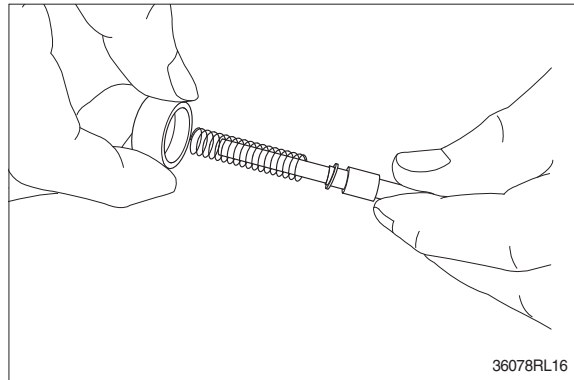

- (2) Stand spool vertically with its bottom placed on flat workbench, and with spring seat pushed down, put two pieces of semicircular stopper (7) on spring seat without piling them on.

- ※ Assemble stopper (7) so that its sharp edge side will be caught by head of spool. Do not push down spring seat more than 6mm.

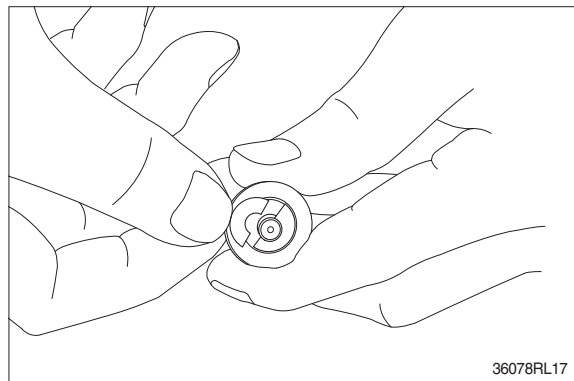

- (3) Assemble spring (9) into casing (1).
Assemble reducing valve subassembly into casing.

- ※ Assemble them to their original positions.

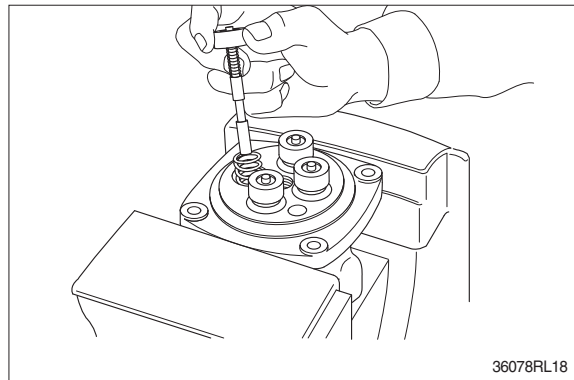

- (4) Assemble O-ring (14) onto plug (13).

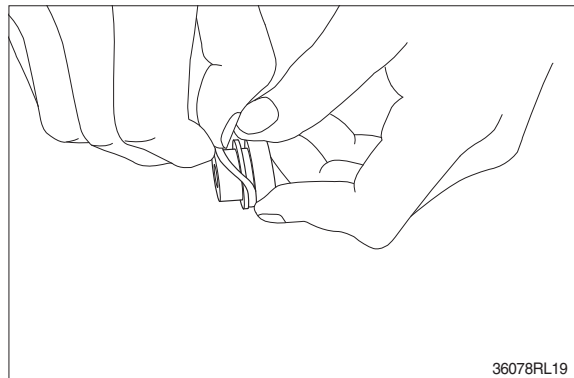

(5) Assemble seal (15) to plug (13).

- ※ Assemble seal in such lip direction as shown below.

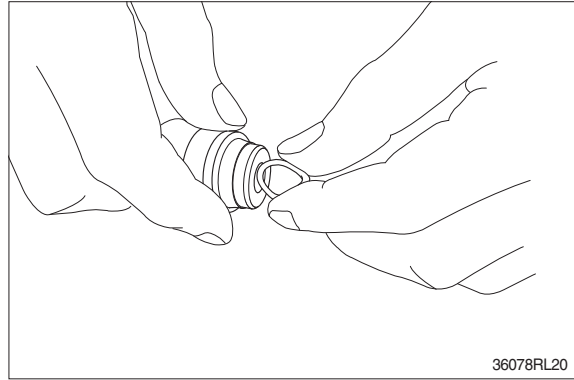

(6) Assemble push rod (10) to plug (13).

- ※ Apply working oil on push-rod surface.

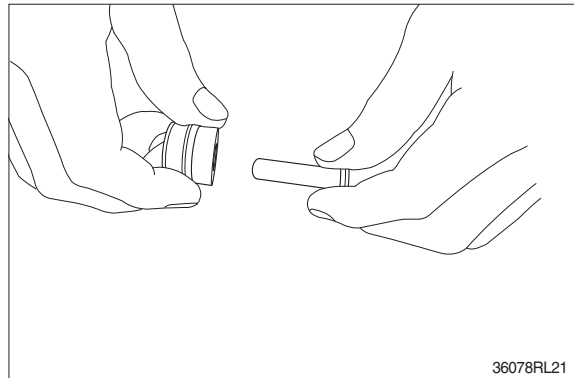

(7) Assemble plug subassembly to casing.

- ※ When return spring is weak in force, subassembly stops due to resistance of O-ring.

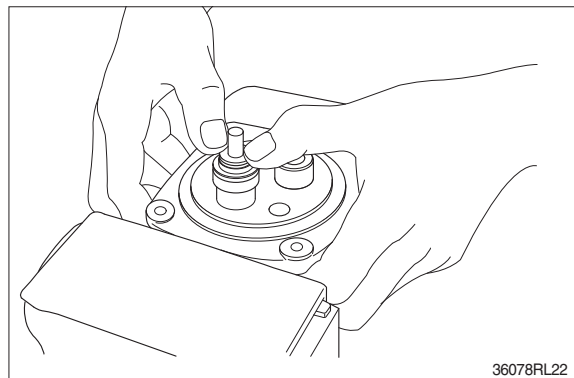

(8) When return spring is strong in force, assemble 4 sets at the same time, utilizing plate (16), and tighten joint (18) temporarily.

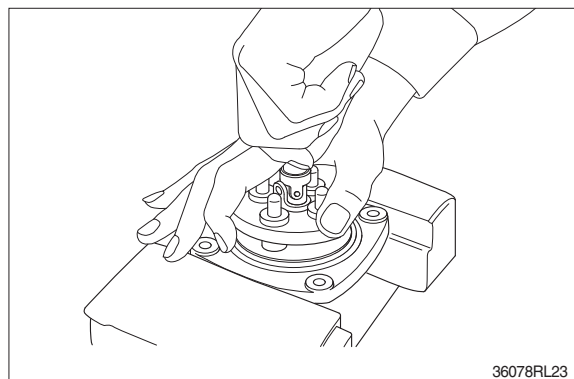

(9) Fit plate (16).

(10) Tighten joint (18) with the specified torque to casing, utilizing jig.

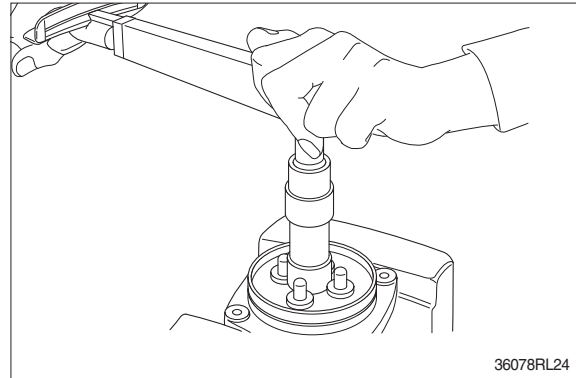

(11) Assemble swash plate (19) to joint (18).

- ※ Screw it to position that it contacts with 4 push rods evenly.
- ※ Do not screw it over.

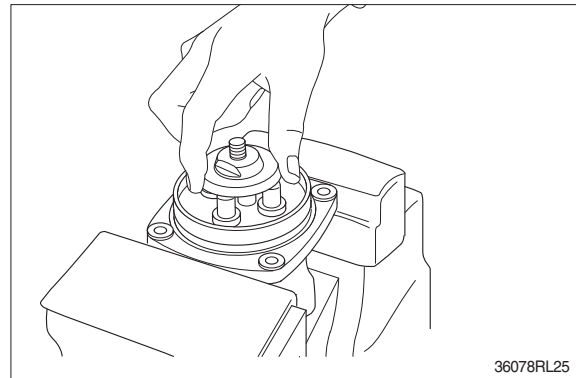

(12) Assemble adjusting nut (20), apply spanner to width across flat of plate (19) to fix it, and tighten adjusting nut to the specified torque.

- ※ During tightening, do not change position of disk.

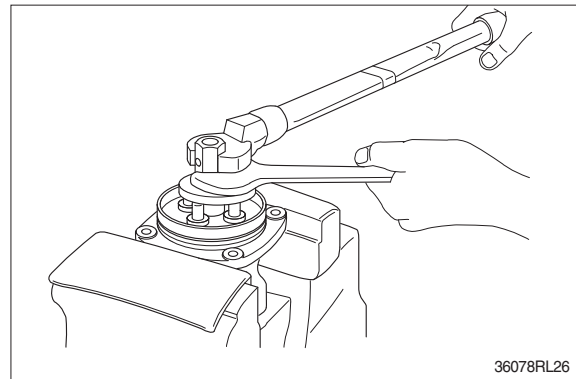

(13) Fit boot (17) to plate.

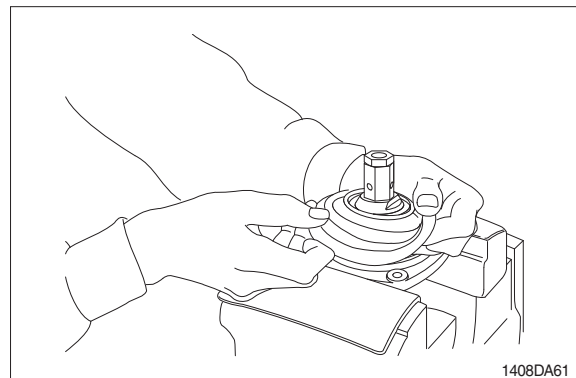

(14) Fit boot (25) and lock nut (21), and handle subassembly is assembled completely.

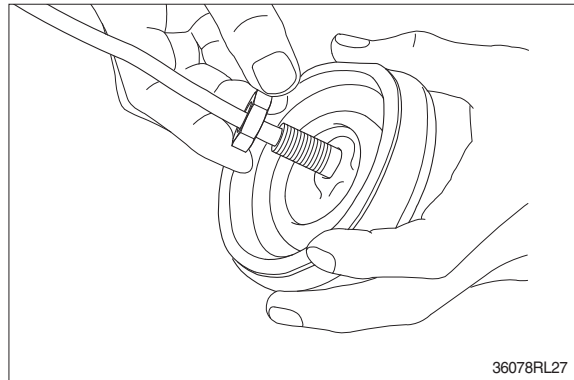
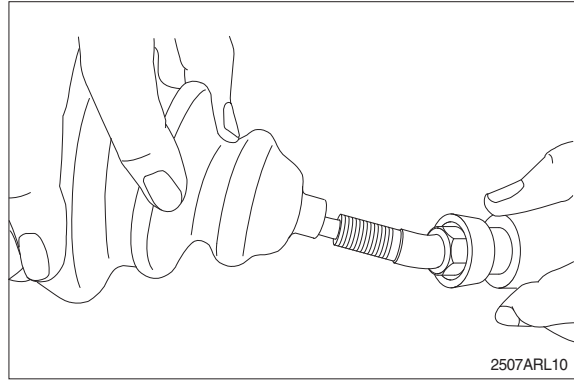

(15) Pull out cord and tube through adjusting nut hole provided in direction 60° to 120° from casing hole.

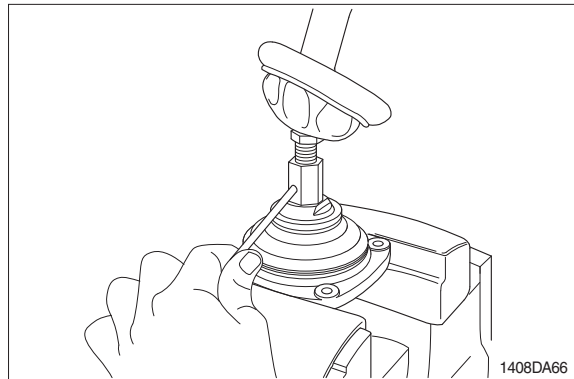

(16) Assemble bushing (27) to plate and pass cord and tube through it.
※ Provide margin necessary to operation.

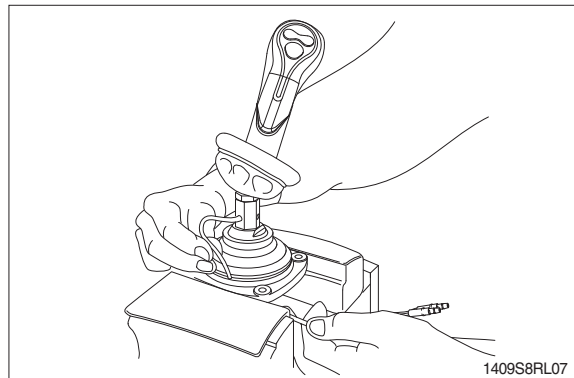

(17) Determine handle direction, tighten lock nut (22) to specified torque to fix handle.

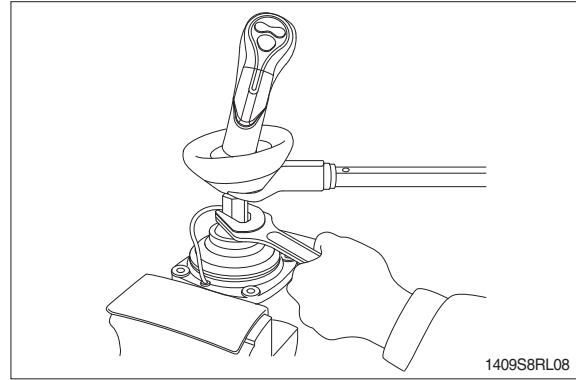

(18) Apply grease to rotating section of joint and contacting faces of disk and push rod.

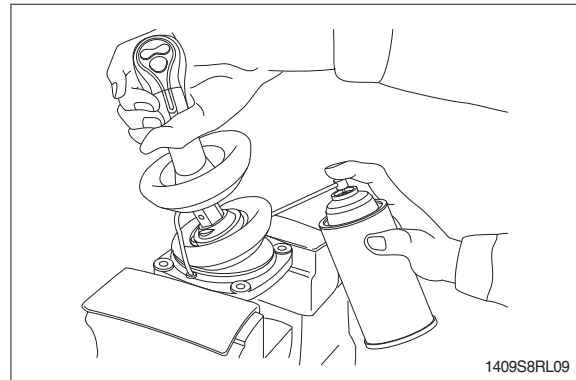

(19) Assemble lower end of bellows to casing.
(20) Inject volatile rust-preventives through all ports and then put blind plugs in ports.

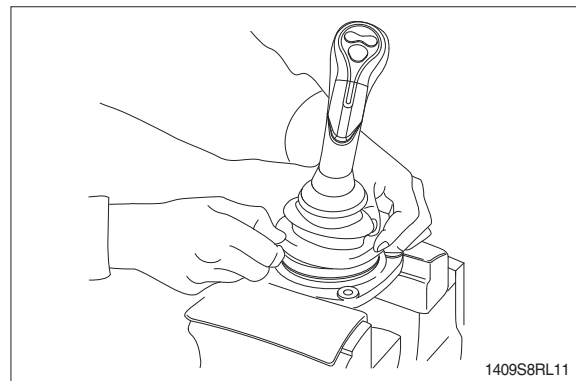

GROUP 8 TURNING JOINT

1. REMOVAL AND INSTALL

1) REMOVAL

- (1) Lower the work equipment to the ground and stop the engine.
- (2) Operate the control levers and pedals several times to release the remaining pressure in the hydraulic piping.
- (3) Loosen the breather slowly to release the pressure inside the hydraulic tank.

▲ Escaping fluid under pressure can penetrate the skin causing serious injury.

※ When pipes and hoses are disconnected, the oil inside the piping will flow out, so catch it in oil pan.

- (4) Disconnect all hoses.
- (5) Sling the turning joint assembly (1) and remove the mounting bolt (2).
 - Weight : 50 kg (110 lb)
 - Tightening torque : $12.3 \pm 1.3 \text{ kgf} \cdot \text{m}$
($88.9 \pm 9.4 \text{ lbf} \cdot \text{ft}$)

- (6) Remove the turning joint assembly.
 - ※ When removing the turning joint, check that all the hoses have been disconnected.

2) INSTALL

- (1) Carry out installation in the reverse order to removal.
 - ※ Take care of turning joint direction.
 - ※ Assemble hoses to their original positions.
 - ※ Confirm the hydraulic oil level and check the hydraulic oil leak or not.

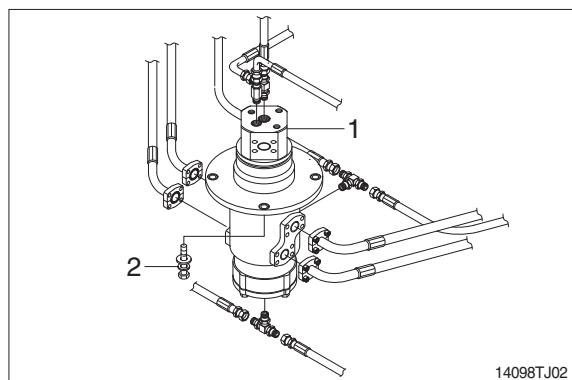
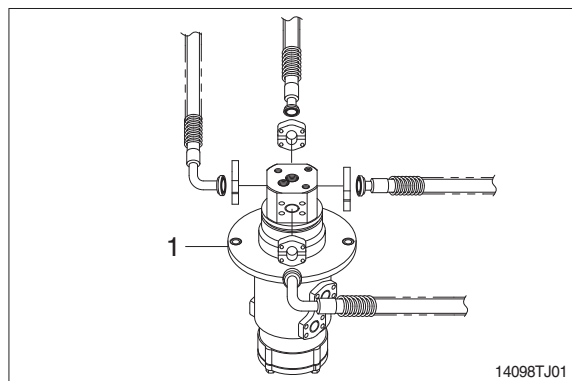

2. DISASSEMBLY AND ASSEMBLY

1) STRUCTURE

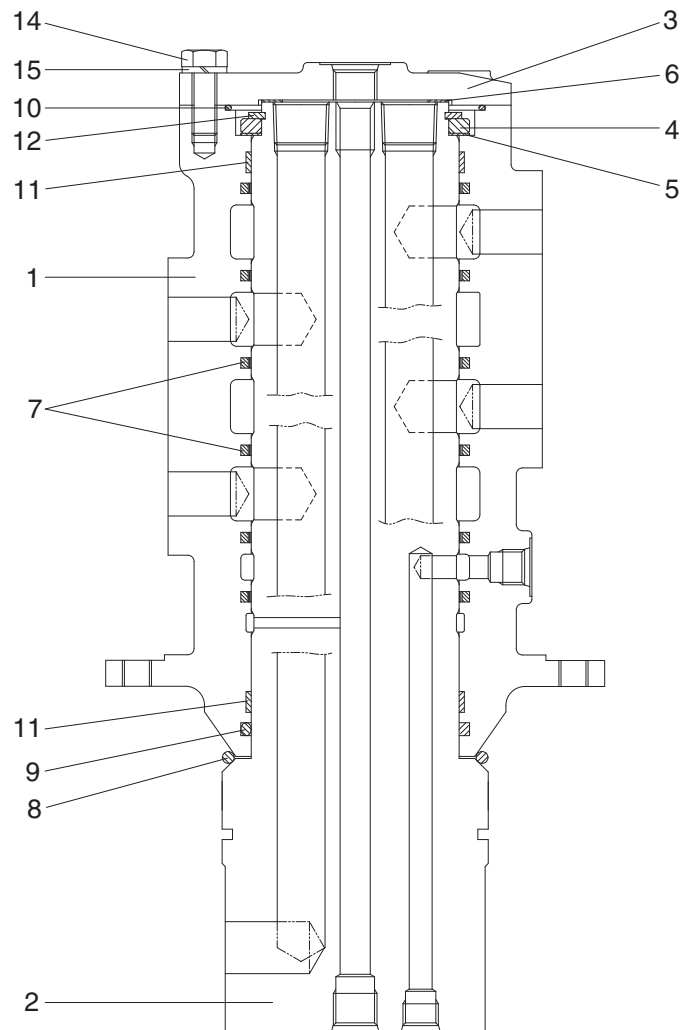

14098TJ03

- | | | | | | |
|---|--------|----|--------------|----|---------------|
| 1 | Hub | 6 | Shim | 11 | Wear ring |
| 2 | Shaft | 7 | Slipper seal | 12 | Retainer ring |
| 3 | Cover | 8 | O-ring | 13 | Plug |
| 4 | Spacer | 9 | O-ring | 14 | Hexagon bolt |
| 5 | Shim | 10 | O-ring | 15 | Spring washer |

2) DISASSEMBLY

※ Before the disassembly, clean the turning joint.

(1) Remove bolts (14), washer (15) and cover (3).

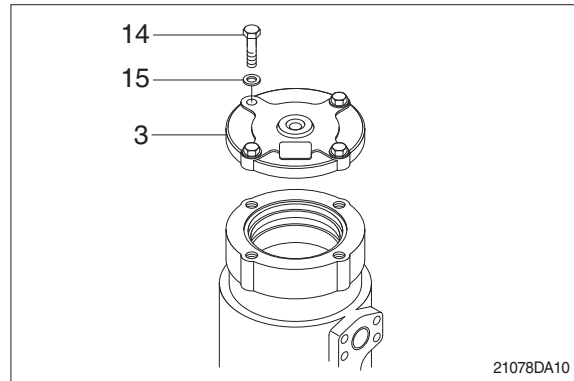

(2) Remove shim (6) and O-ring (10).

(3) Remove retainer ring (12), spacer (4) and shim (5).

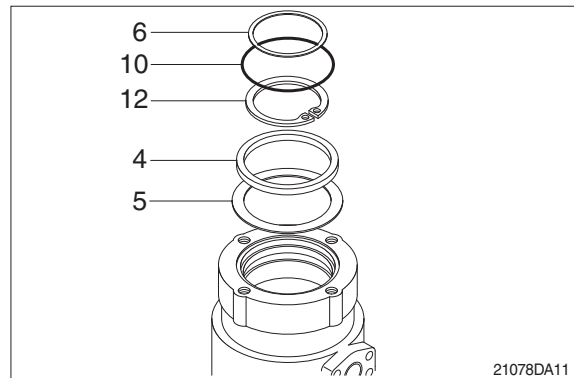

(4) Place hub (1) on a V-block and by using a wood buffer at the shaft end, hit out shaft (2) to about 1/2 from the body with a hammer.

※ Take care not to damage the shaft (2) when remove hub (1) or rest it sideways.

※ Put a fitting mark on hub (1) and shaft (2).

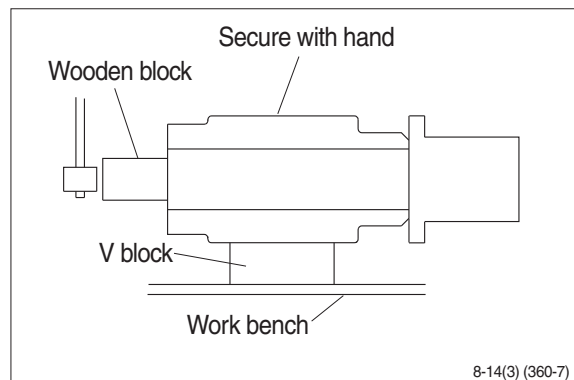

(5) Remove six slipper seals (7) and O-ring (9), two wear ring (11) from hub (1).

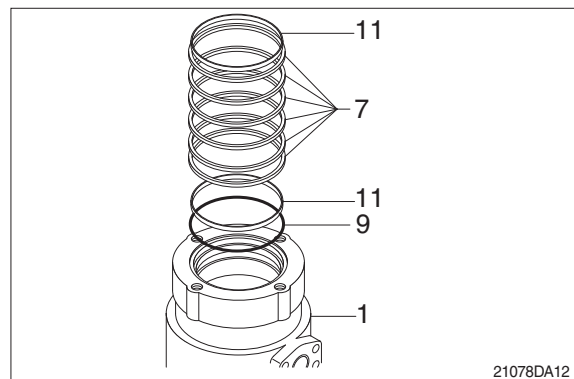

3) ASSEMBLY

- ※ Clean all parts.
- ※ As a general rule, replace oil seals and O-ring.
- ※ Coat the sliding surfaces of all parts with engine oil or grease before installing.

(1) Fix seven slipper seal (7) and O-ring (9), two wear ring (11) to hub (1).

(2) Fit O-ring (8) to shaft (2).

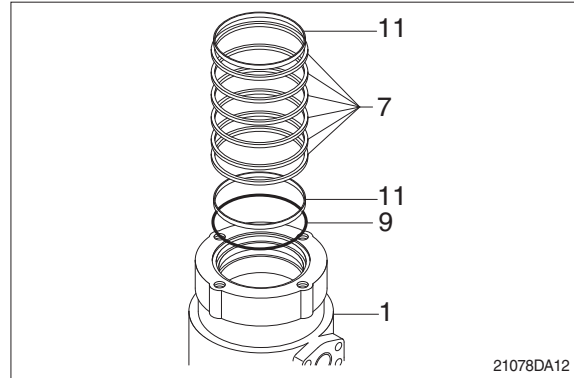

(3) Set shaft (2) on block, tap hub (1) with a plastic hammer to install.

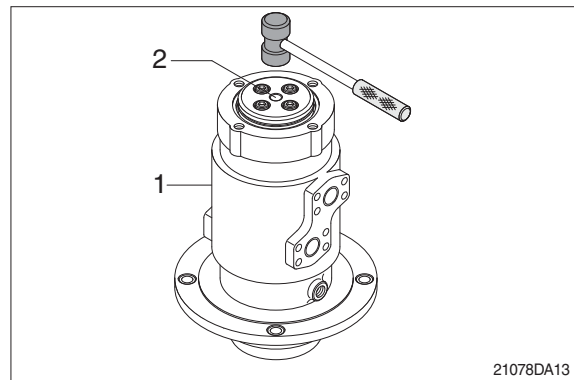

(4) Fit shim (5), spacer (4) and retainer ring (12) to shaft (2).

(5) Fit O-ring (10) to hub (1).

(6) Fit shim (6) to shaft (2).

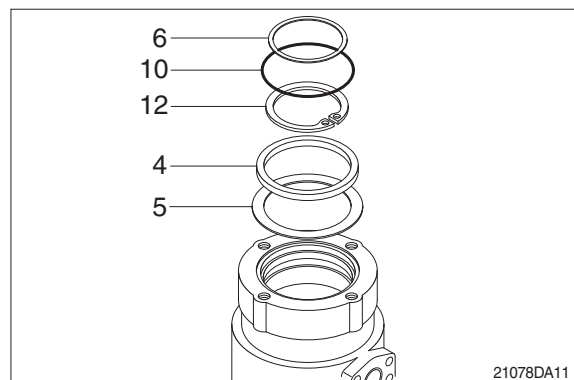

- (7) Install cover (3) to body (1) and tighten bolts (14).
- Torque : 10~12.5 kgf · m
(72.3~90.4 lbf · ft)

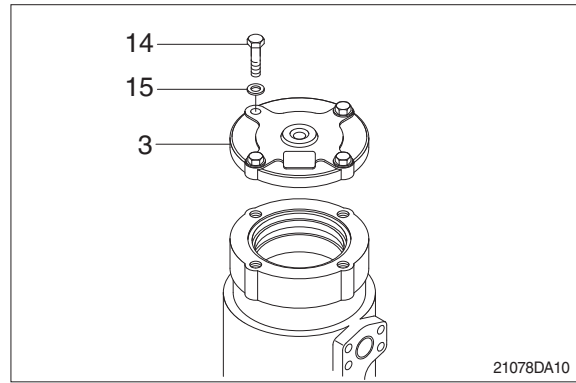

GROUP 9 BOOM, ARM AND BUCKET CYLINDERS

1. REMOVAL AND INSTALL

1) BUCKET CYLINDER

(1) Removal

- ※ Expand the arm and bucket fully, lower the work equipment to the ground and stop the engine.
- ※ Operate the control levers and pedals several times to release the remaining pressure in the hydraulic piping.
- ※ Loosen the breather slowly to release the pressure inside the hydraulic tank.

▲ Escaping fluid under pressure can penetrate the skin causing serious injury.

- ※ Fit blind plugs in the hoses after disconnecting them, to prevent dirt or dust from entering.

① Set block between bucket cylinder and arm.

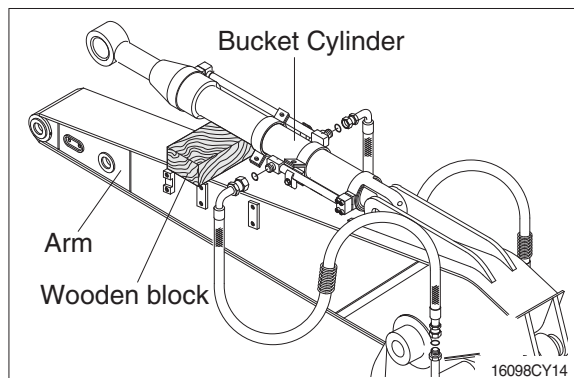

② Remove bolt (2), nut (3) and pull out pin (1).

- ※ Tie the rod with wire to prevent it from coming out.

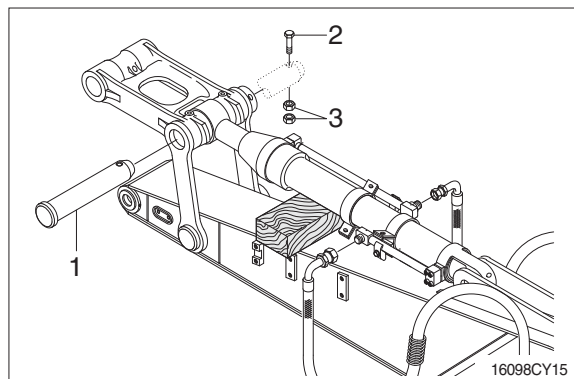

③ Disconnect bucket cylinder hoses (4) and put plugs (5) on cylinder pipe.

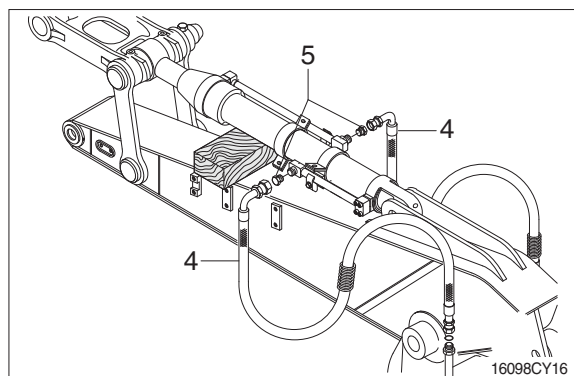

- ④ Sling bucket cylinder assembly (8) and remove bolt (6) then pull out pin (5).
- ⑤ Remove bucket cylinder assembly (8).
 - Weight : 125 kg (280 lb)

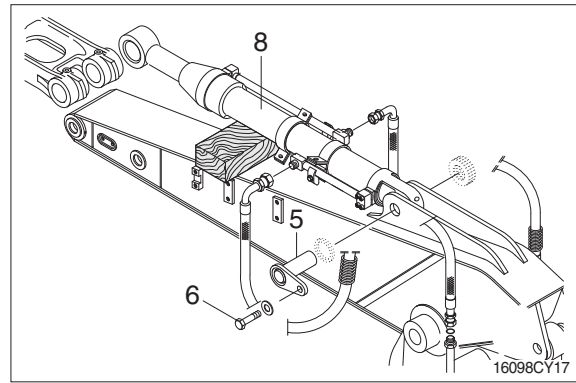

(2) Install

- ① Carry out installation in the reverse order to removal.
- ▲ When aligning the mounting position of the pin, do not insert your fingers in the pin hole.**
- ※ Bleed the air from the bucket cylinder.
 - ※ Confirm the hydraulic oil level and check the hydraulic oil leak or not.

2) ARM CYLINDER

(1) Removal

- ※ Expand the arm and bucket fully, lower the work equipment to the ground and stop the engine.
- ※ Operate the control levers and pedals several times to release the remaining pressure in the hydraulic piping.
- ※ Loosen the breather slowly to release the pressure inside the hydraulic tank.

▲ Escaping fluid under pressure can penetrate the skin causing serious injury. Fit blind plugs in the hoses after disconnecting them, to prevent dirt or dust from entering.

- ① Set block between arm cylinder and boom.

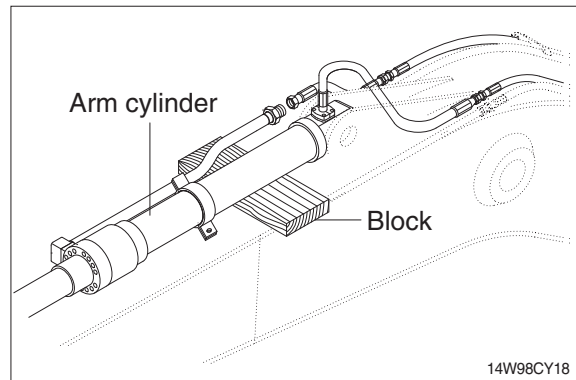

- ② Remove bolt (2) and pull out pin (1).

- ※ Tie the rod with wire to prevent it from coming out.

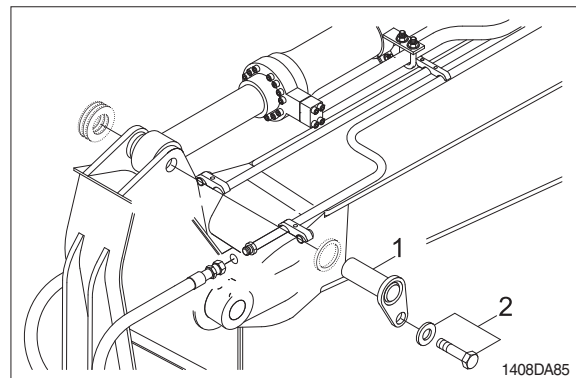

- ③ Disconnect arm cylinder hoses (4) and put plugs on cylinder pipe.

- ④ Disconnect greasing pipings (5).

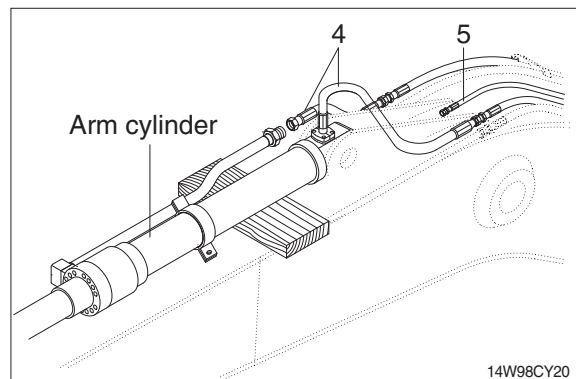

- ⑤ Sling arm cylinder assembly(8) and remove bolt (7) then pull out pin (6).
- ⑥ Remove arm cylinder assembly (8).
 - Weight : 180 kg (400 lb)

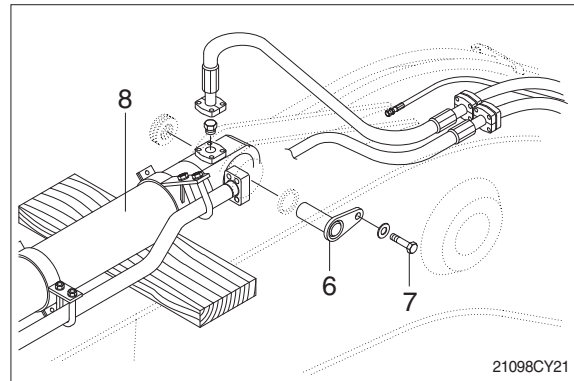

(2) Install

- ① Carry out installation in the reverse order to removal.
- ▲ When aligning the mounting position of the pin, do not insert your fingers in the pin hole.**
- ※ Bleed the air from the arm cylinder.
 - ※ Confirm the hydraulic oil level and check the hydraulic oil leak or not.

3) BOOM CYLINDER

(1) Removal

- ※ Expand the arm and bucket fully, lower the work equipment to the ground and stop the engine.
- ※ Operate the control levers and pedals several times to release the remaining pressure in the hydraulic piping.
- ※ Loosen the breather slowly to release the pressure inside the hydraulic tank.

▲ Escaping fluid under pressure can penetrate the skin causing serious injury.

- ※ Fit blind plugs in the hoses after disconnecting them, to prevent dirt or dust from entering.
- ① Disconnect greasing hoses (1).
 - ② Sling boom cylinder assembly.

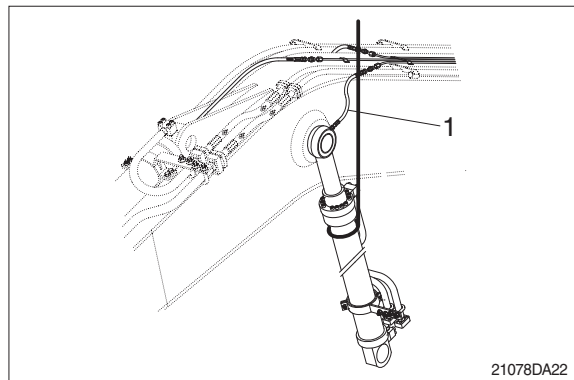

- ③ Remove bolt (4), stopper (5) and pull out pin (2).
- ※ Tie the rod with wire to prevent it from coming out.

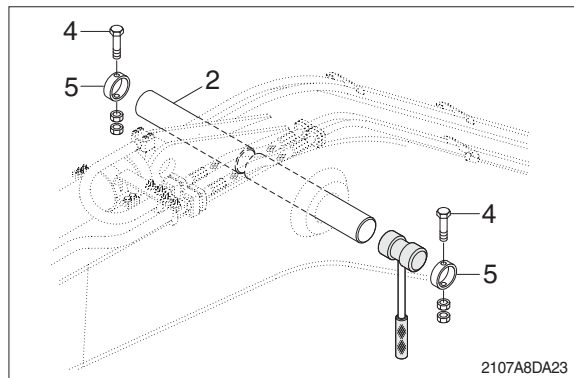

- ④ Lower the boom cylinder assembly (6) on a stand.

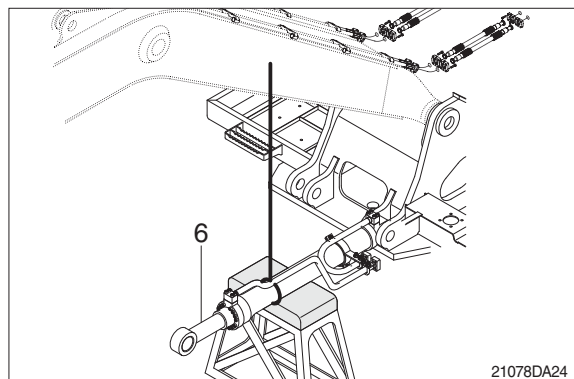

- ⑤ Disconnect boom cylinder hoses (7) and put plugs on cylinder pipe.

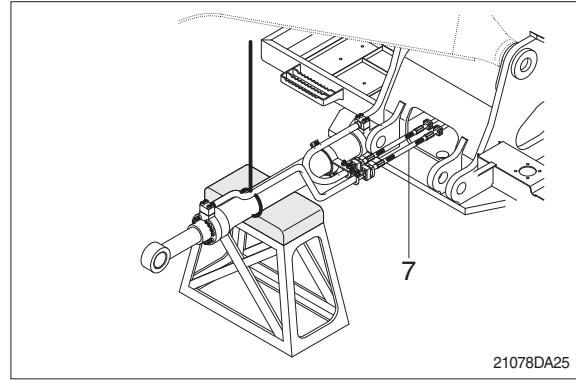

- ⑥ Remove bolt (9) and pull out pin (8).
⑦ Remove boom cylinder assembly (6).
· Weight : 155 kg (340 lb)

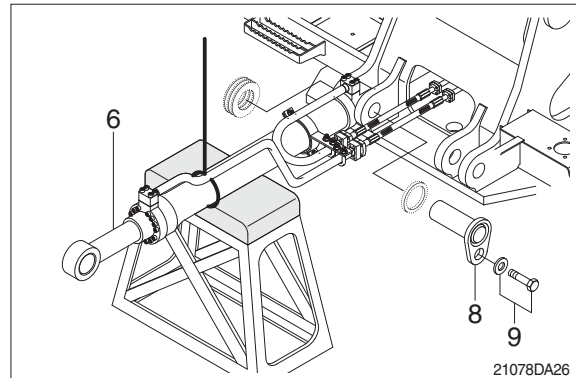

(2) Install

- ① Carry out installation in the reverse order to removal.
- ▲ **When aligning the mounting position of the pin, do not insert your fingers in the pin hole.**
- ※ Bleed the air from the boom cylinder.
 - ※ Confirmed the hydraulic oil level and check the hydraulic oil leak or not.

2. DISASSEMBLY AND ASSEMBLY

1) STRUCTURE

(1) Bucket cylinder

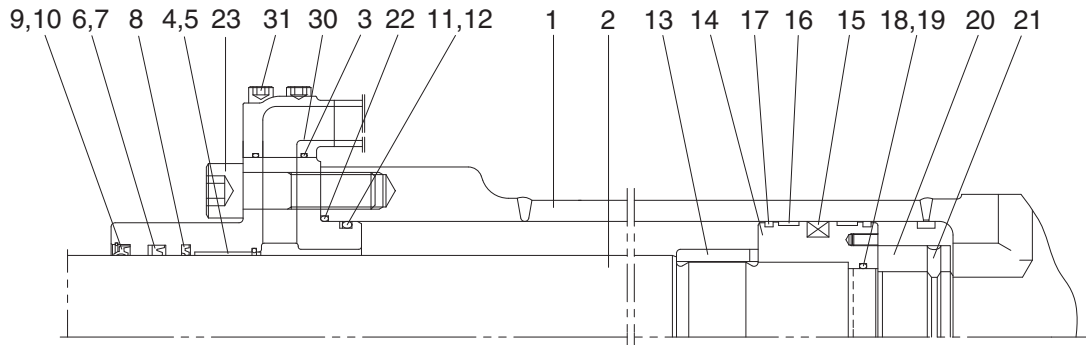

Internal detail

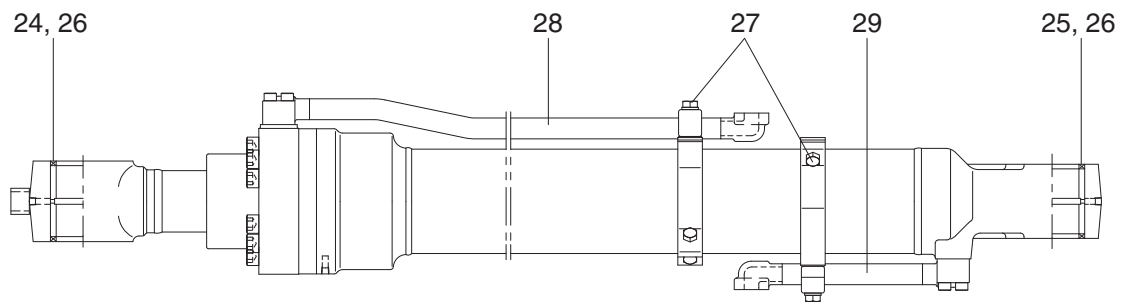

16098CY01

1	Tube assembly	12	Back up ring	23	Hexagon socket head bolt
2	Rod assembly	13	Cushion ring	24	Pin bushing
3	Gland	14	Piston	25	Pin bushing
4	DD2 bushing	15	Piston seal	26	Dust seal
5	Snap ring	16	Wear ring	27	Band assembly
6	Rod seal	17	Dust ring	28	Pipe assembly-R
7	Back up ring	18	O-ring	29	Pipe assembly-B
8	Buffer ring	19	Back up ring	30	O-ring
9	Dust wiper	20	Lock nut	31	Hexagon socket head bolt
10	Snap ring	21	Hexagon socket set screw		
11	O-ring	22	O-ring		

(2) Arm cylinder

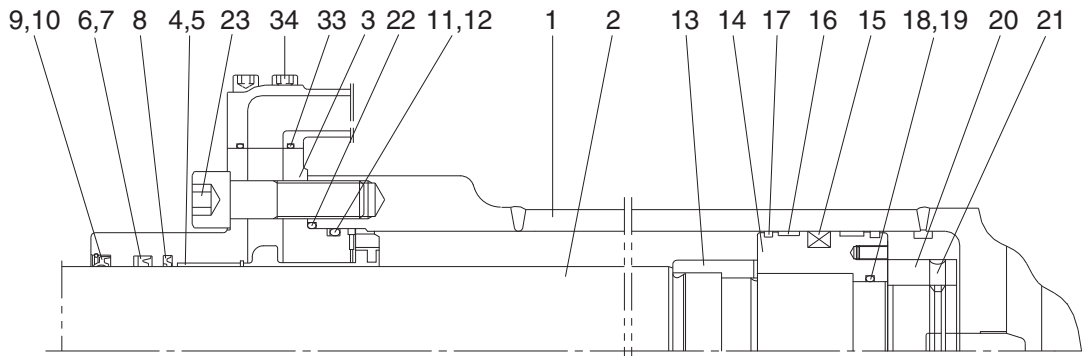

Internal detail

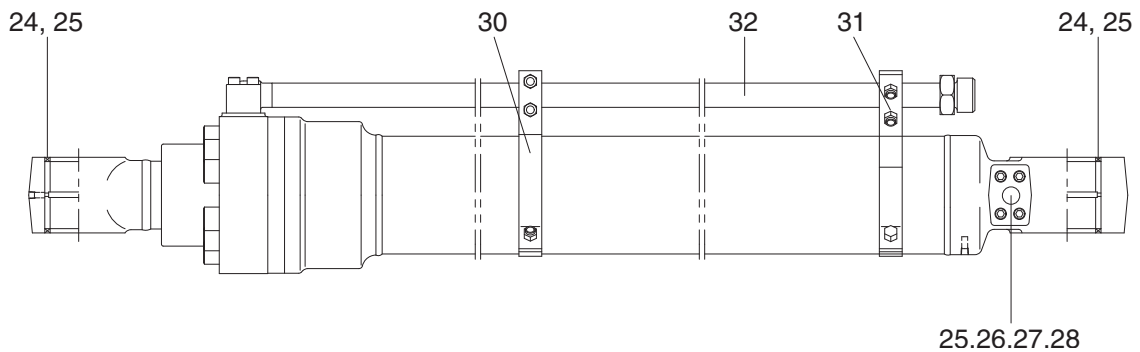

16098CY02

- | | | | | | |
|----|---------------|----|--------------------------|----|--------------------------|
| 1 | Tube assembly | 13 | Cushion ring | 25 | Dust seal |
| 2 | Rod assembly | 14 | Piston | 26 | Check valve |
| 3 | Gland | 15 | Piston seal | 27 | Coil spring |
| 4 | DD2 bushing | 16 | Wear ring | 28 | O-ring |
| 5 | Snap ring | 17 | Dust ring | 29 | Plug |
| 6 | Rod seal | 18 | O-ring | 30 | Band assembly-R |
| 7 | Back up ring | 19 | Back up ring | 31 | Band assembly-B |
| 8 | Buffer ring | 20 | Lock nut | 32 | Pipe assembly-R |
| 9 | Dust wiper | 21 | Hexagon socket set screw | 33 | O-ring |
| 10 | Snap ring | 22 | O-ring | 34 | Hexagon socket head bolt |
| 11 | O-ring | 23 | Hexagon socket head bolt | | |
| 12 | Back up ring | 24 | Pin bushing | | |

(3) Boom cylinder

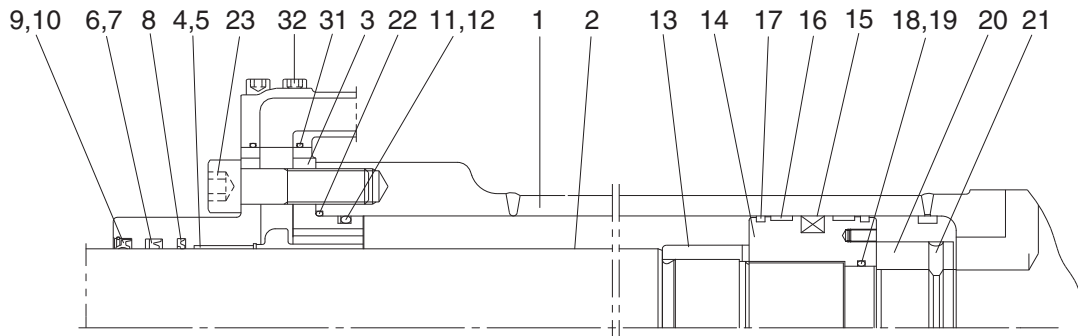

Internal detail

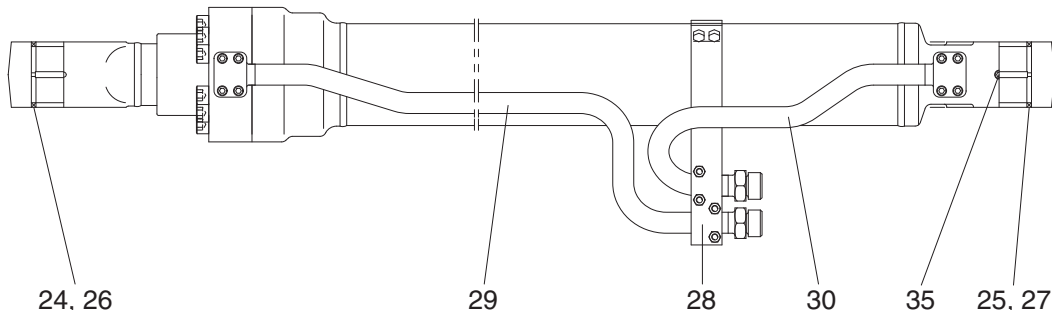

16098CY03

- | | | | | | |
|----|---------------|----|--------------------------|----|--------------------------|
| 1 | Tube assembly | 12 | Back up ring | 23 | Hexagon socket head bolt |
| 2 | Rod assembly | 13 | Cushion ring | 24 | Pin bushing |
| 3 | Gland | 14 | Piston | 25 | Pin bushing |
| 4 | DD2 bushing | 15 | Piston seal | 26 | Dust seal |
| 5 | Snap ring | 16 | Wear ring | 27 | Dust seal |
| 6 | Rod seal | 17 | Dust ring | 28 | Band assembly |
| 7 | Back up ring | 18 | O-ring | 29 | Pipe assembly-R |
| 8 | Buffer ring | 19 | Back up ring | 30 | Pipe assembly-B |
| 9 | Dust wiper | 20 | Lock nut | 31 | O-ring |
| 10 | Snap ring | 21 | Hexagon socket set screw | 32 | Hexagon socket head bolt |
| 11 | O-ring | 22 | O-ring | | |

(4) Dozer cylinder

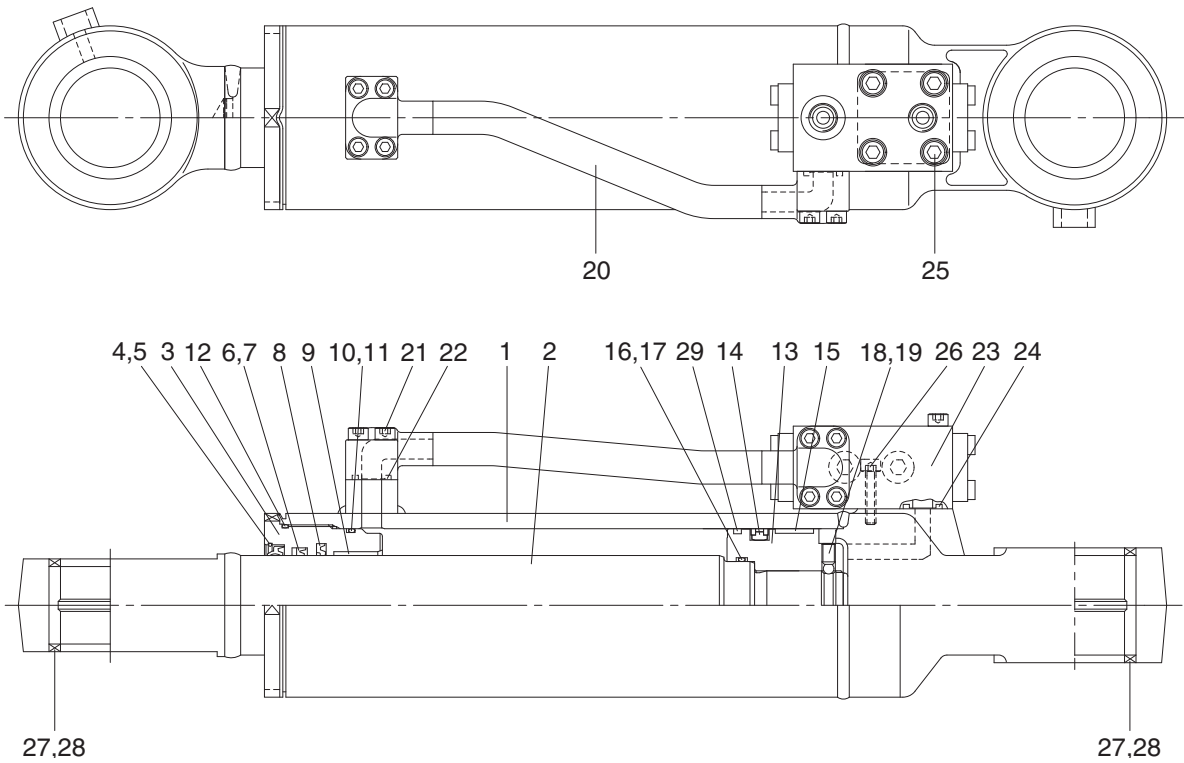

16098CY05

1	Tube assembly	11	Back up ring	21	Hexagon socket head bolt
2	Rod assembly	12	O-ring	22	O-ring
3	Gland	13	Piston	23	Check valve assembly
4	Dust wiper	14	Piston seal	24	O-ring
5	Retainer ring	15	Wear ring	25	Hexagon socket head bolt
6	Rod seal	16	O-ring	26	Hexagon socket head bolt
7	Back up ring	17	Back up ring	27	Pin bushing
8	Buffer ring	18	Steel ball	28	Dust seal
9	DU bushing	19	Set screw	29	Dust ring
10	O-ring	20	Pipe assembly		

2) TOOLS AND TIGHTENING TORQUE

(1) Tools

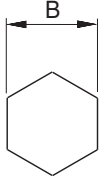
Tool name	Remark		
Allen wrench	6		
	8		
	14		
	17		
Spanner	7		
	8		
(-) Driver	Small and large sizes		
Torque wrench	Capable of tightening with the specified torques		

(2) Tightening torque

Part name		Item	Size	Torque	
				kgf · m	lbf · ft
Gland mounting socket head bolt	Bucket cylinder	23	M14 × 2.0	15 ± 2.0	108 ± 14.5
	Boom cylinder		M16 × 2.0	23 ± 2.0	166 ± 14.5
	Arm cylinder		M16 × 2.0	23 ± 2.0	166 ± 14.5
	Dozer cylinder	21	M 8 × 1.25	2.7 ± 0.3	19.5 ± 2.2
		25	M10 × 1.5	5.4 ± 0.5	39.1 ± 3.6
Pipe mounting socket head bolt	Bucket	31	M10 × 1.5	5.4 ± 0.5	39.1 ± 3.6
	Boom	32			
	Arm	34			
Lock nut	Bucket cylinder	20	M52 × 2.0	100 ± 10.0	723 ± 72.3
	Boom cylinder		M56 × 2.0		
	Arm cylinder		M56 × 2.0		
Piston	Bucket cylinder	14	-	150 ± 15.0	1085 ± 109
	Boom cylinder				
	Arm cylinder				
	Dozer cylinder - Rear	13	M68 × 3.0	170 ± 17.0	1230 ± 123
Set screw	Bucket cylinder	21	M 8 × 1.25	2.7 ± 0.3	19.5 ± 2.2
	Boom cylinder				
	Arm cylinder				
	Dozer cylinder - Rear	19			

3) DISASSEMBLY

(1) Remove cylinder head and piston rod

※ Procedures are based on the bucket cylinder.

① Hold the clevis section of the tube in a vise.

※ Use mouth pieces so as not to damage the machined surface of the cylinder tube. Do not make use of the outside piping as a locking means.

② Pull out rod assembly (2) about 200 mm (7.1 in). Because the rod assembly is rather heavy, finish extending it with air pressure after the oil draining operation.

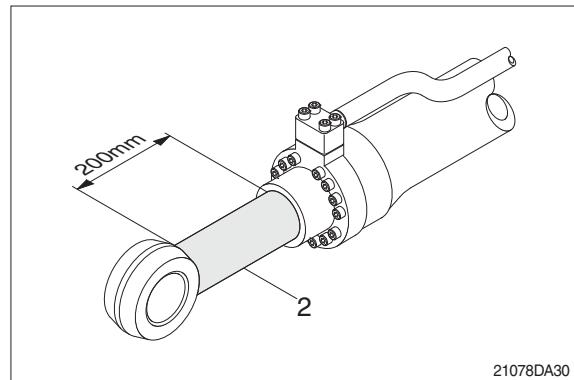

③ Loosen and remove socket bolts (23) of the gland in sequence.

※ Cover the extracted rod assembly (2) with rag to prevent it from being accidentally damaged during operation.

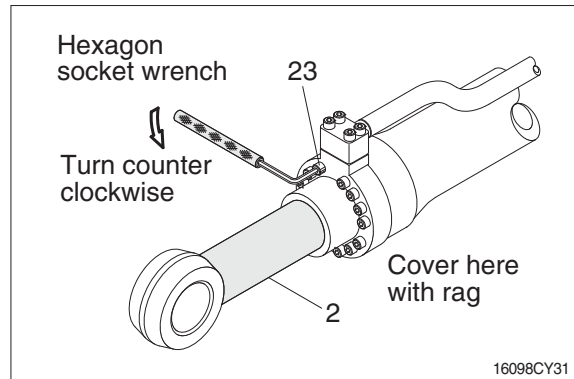

④ Draw out cylinder head and rod assembly together from tube assembly (1).

※ Since the rod assembly is heavy in this case, lift the tip of the rod assembly (2) with a crane or some means and draw it out. However, when rod assembly (2) has been drawn out to approximately two thirds of its length, lift it in its center to draw it completely.

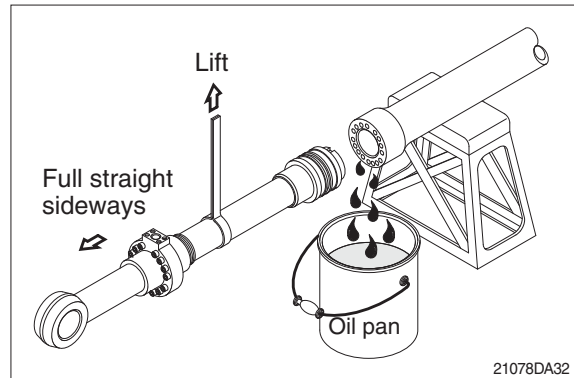

Note that the plated surface of rod assembly (2) is to be lifted. For this reason, do not use a wire sling and others that may damage it, but use a strong cloth belt or a rope.

- ⑤ Place the removed rod assembly on a wooden V-block that is set level.
- ※ Cover a V-block with soft rag.

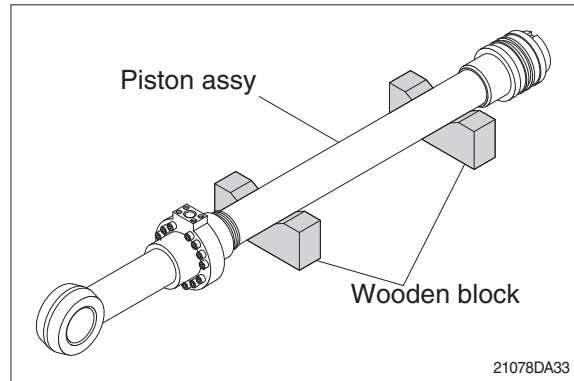

(2) Remove piston and cylinder head

- ① Remove set screw (21).
- ※ Since set screw (21) and lock nut (20) is tightened to a high torque, use a hydraulic and power wrench that utilizes a hydraulic cylinder, to remove the lock set screw (21) and lock nut (20).
- ② Remove piston assembly (14), back up ring (19), and O-ring (18).

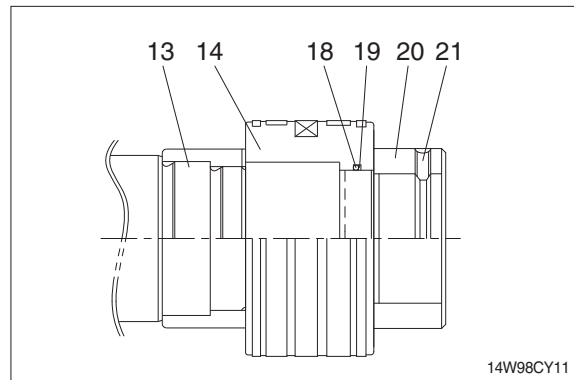

- ③ Remove the cylinder head assembly from rod assembly (2).
 - ※ If it is too heavy to move, move it by striking the flanged part of cylinder head with a plastic hammer.
 - ※ Pull it straight with cylinder head assembly lifted with a crane.
- Exercise care so as not to damage the lip of rod bushing (4) and packing (5, 6, 7, 8, 9, 10) by the threads of rod assembly (2).

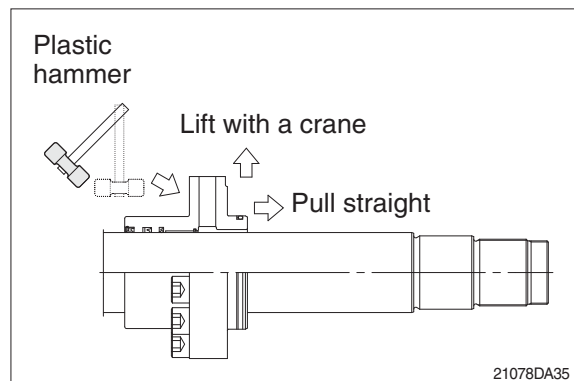

(3) Disassemble the piston assembly

- ① Remove wear ring (16).
 - ② Remove dust ring (17) and piston seal (15).
- ※ Exercise care in this operation not to damage the grooves.

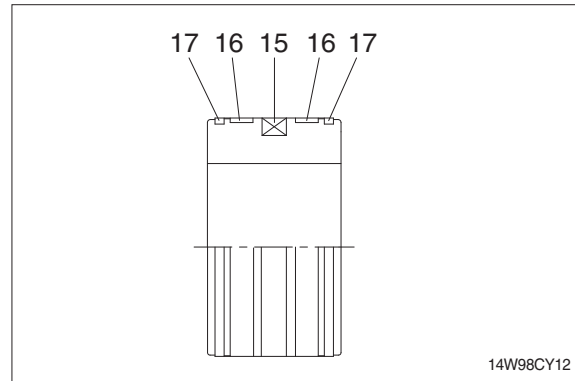

(4) Disassemble cylinder head assembly

- ① Remove back up ring (12) and O-ring (11).
 - ② Remove snap ring (10), dust wiper (9).
 - ③ Remove back up ring (7), rod seal (6) and buffer ring (8).
- ※ Exercise care in this operation not to damage the grooves.
- ※ Do not remove seal and ring, if does not damaged.
- ※ Do not remove bushing (4).

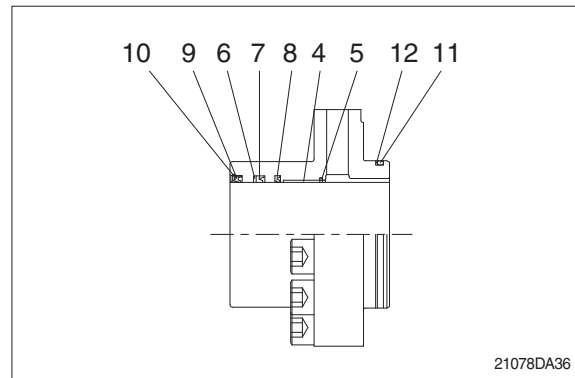

3) ASSEMBLY

(1) Assemble cylinder head assembly

※ Check for scratches or rough surfaces if found smooth with an oil stone.

- ① Coat the inner face of gland (3) with hydraulic oil.

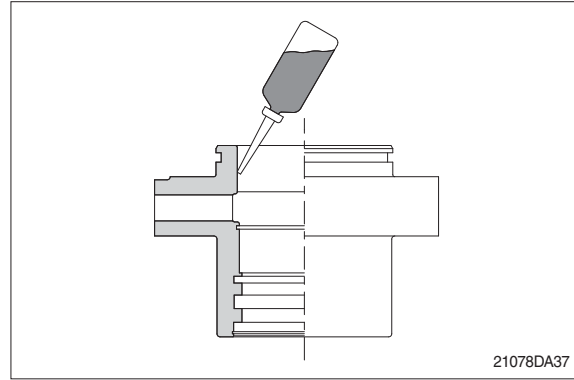

- ② Coat dust wiper (9) with grease and fit dust wiper (9) to the bottom of the hole of dust seal.

At this time, press a pad metal to the metal ring of dust seal.

- ③ Fit snap ring (10) to the stop face.

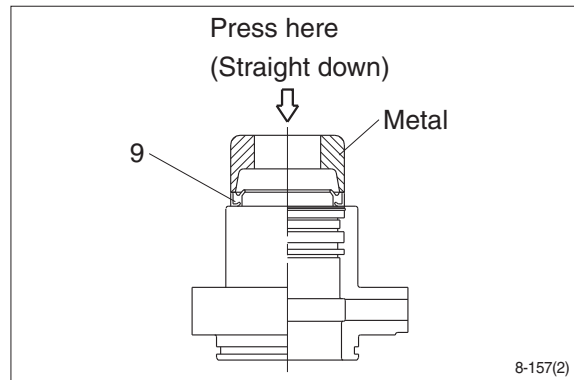

- ④ Fit back up ring (7), rod seal (6) and buffer ring (8) to corresponding grooves, in that order.

※ Coat each packing with hydraulic oil before fitting it.

※ Insert the backup ring until one side of it is inserted into groove.

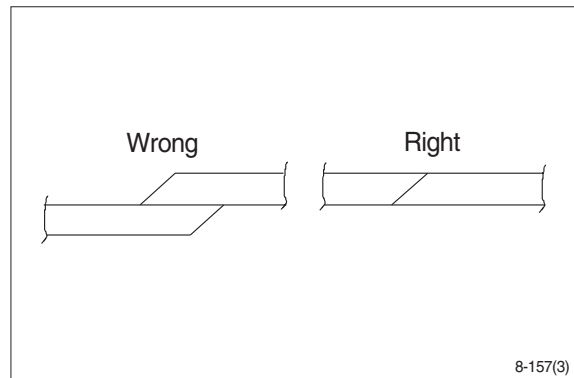

※ Rod seal (6) has its own fitting direction. Therefore, confirm it before fitting them.

※ Fitting rod seal (6) upside down may damage its lip. Therefore check the correct direction that is shown in fig.

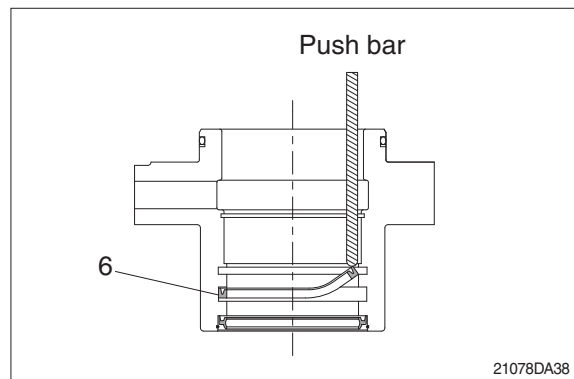

- ⑤ Fit back up ring (12) to gland (3).
- ※ Put the backup ring in the warm water of 30~50°C.
- ⑥ Fit O-ring (11) to gland (3).

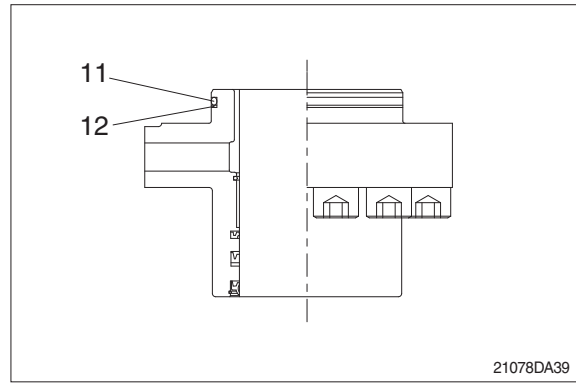

(2) Assemble piston assembly

- ※ Check for scratches or rough surfaces. If found smooth with an oil stone.
- ① Coat the outer face of piston (14) with hydraulic oil.

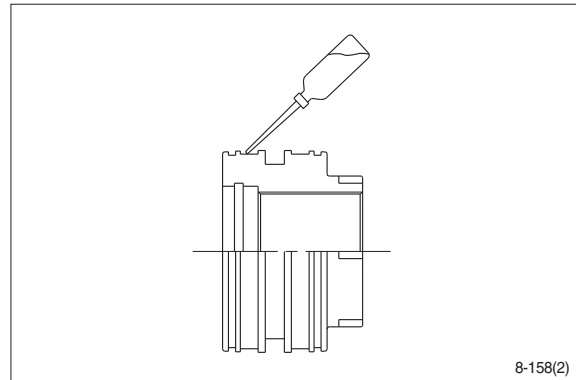

- ② Fit piston seal (15) to piston.
- ※ Put the piston seal in the warm water of 60~100°C for more than 5 minutes.
- ※ After assembling the piston seal, press its outer diameter to fit in.

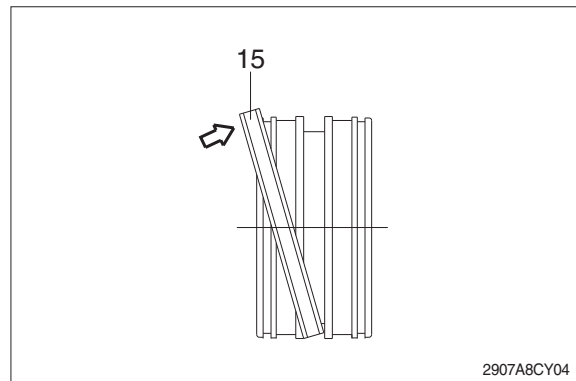

- ③ Fit wear ring (16) and dust ring (17) to piston (14).

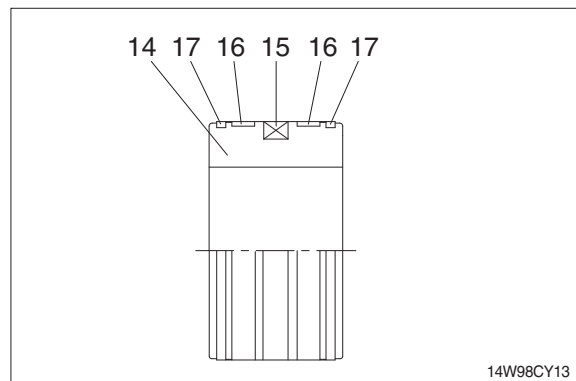

(3) Install piston and cylinder head

- ① Fix the rod assembly to the work bench.
- ② Apply hydraulic oil to the outer surface of rod assembly (2), the inner surface of piston and cylinder head.
- ③ Insert cylinder head assembly to rod assembly.

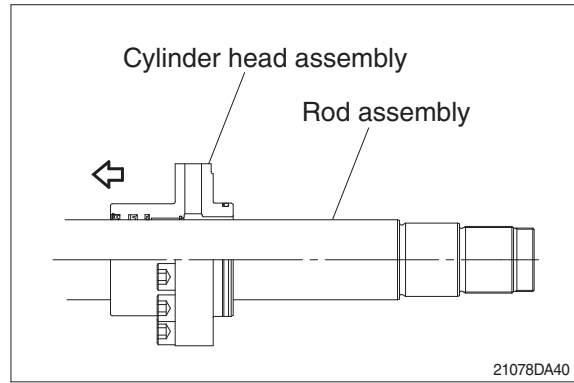

- ④ Insert cushion ring (13) to rod assembly.
- ※ Note that cushion ring (13) has a direction in which it should be fitted.

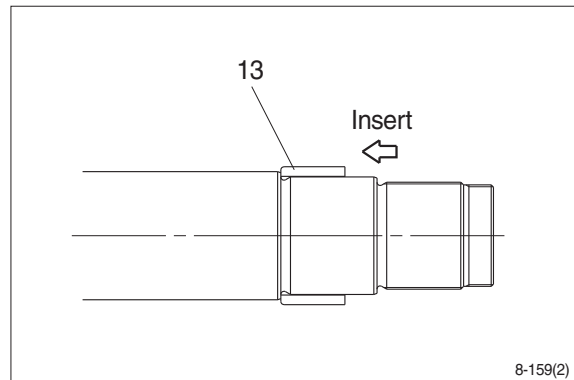

- ⑤ Fit piston assembly to rod assembly.
- Tightening torque : $150 \pm 15 \text{ kgf} \cdot \text{m}$
($1085 \pm 108 \text{ lbf} \cdot \text{ft}$)

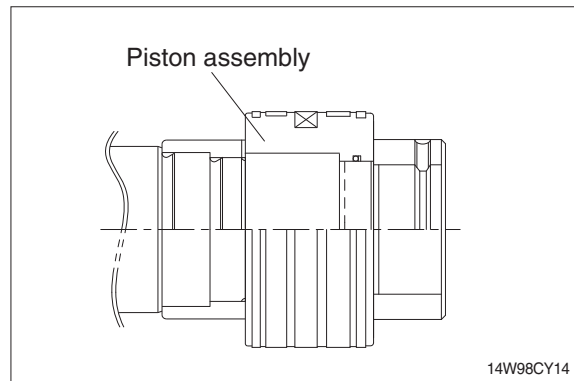

- ⑥ Fit lock nut (20) and tighten the screw (21).
- Tightening torque :

Item		kgf · m	lbf · ft
20	Bucket	100 ± 10	723 ± 72.3
	Boom		
	Arm		
21		2.7 ± 0.3	19.5 ± 2.2

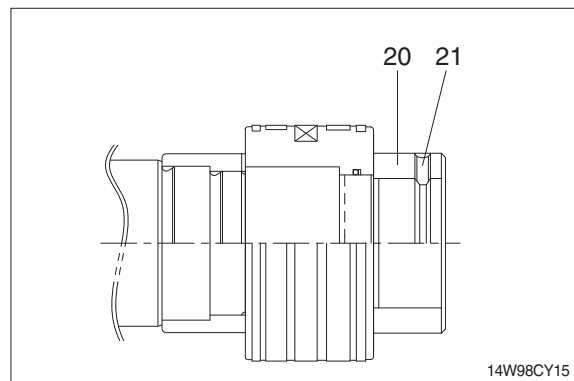

(3) Overall assemble

- ① Place a V-block on a rigid work bench.
Mount the tube assembly (1) on it and fix the assembly by passing a bar through the clevis pin hole to lock the assembly.
- ② Insert the rod assembly in to the tube assembly, while lifting and moving the rod assembly with a crane.
 - ※ Be careful not to damage piston seal by thread of tube assembly.
- ③ Match the bolt holes in the cylinder head flange to the tapped holes in the tube assembly and tighten socket bolts to a specified torque.
 - ※ Refer to the table of tightening torque.

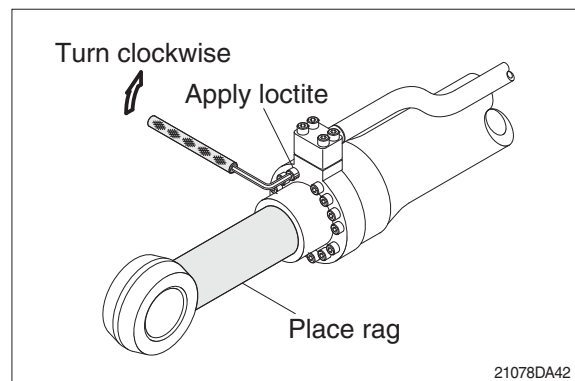
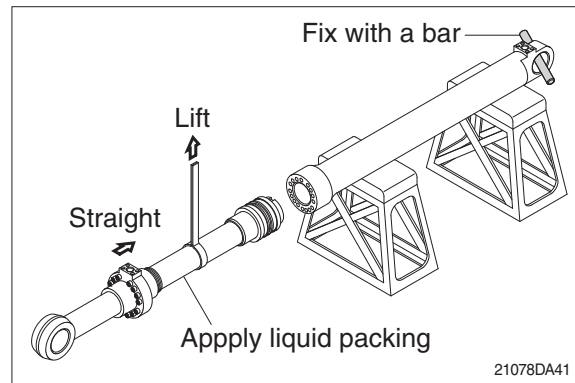

GROUP 10 UNDERCARRIAGE

1. TRACK LINK

1) REMOVAL

(1) Move track link until master pin is over front idler in the position put wooden block as shown.

(2) Loosen tension of the track link.

※ If track tension is not relieved when the grease valve is loosened, move the machine backwards and forwards.

※ Unscrew the grease nipple after release the tension by pushing the poppet only when necessarily required.

Grease leaking hole is not existing. So, while unscrew the grease nipple, grease is not leaking until the grease nipple is completely coming out. If the tension is not released in advance, the grease nipple can be suddenly popped out by pressurized grease.

(3) Push out master pin by using a suitable tool.

(4) Move the machine slowly in reverse, and lay out track link assembly (1).

※ Jack up the machine and put wooden block under the machine.

※ Don't get close to the sprocket side as the track shoe plate may fall down on your feet.

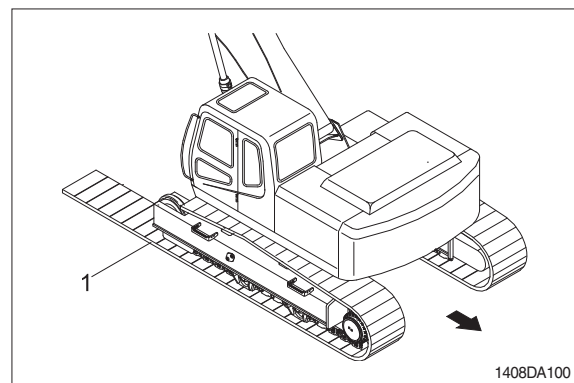
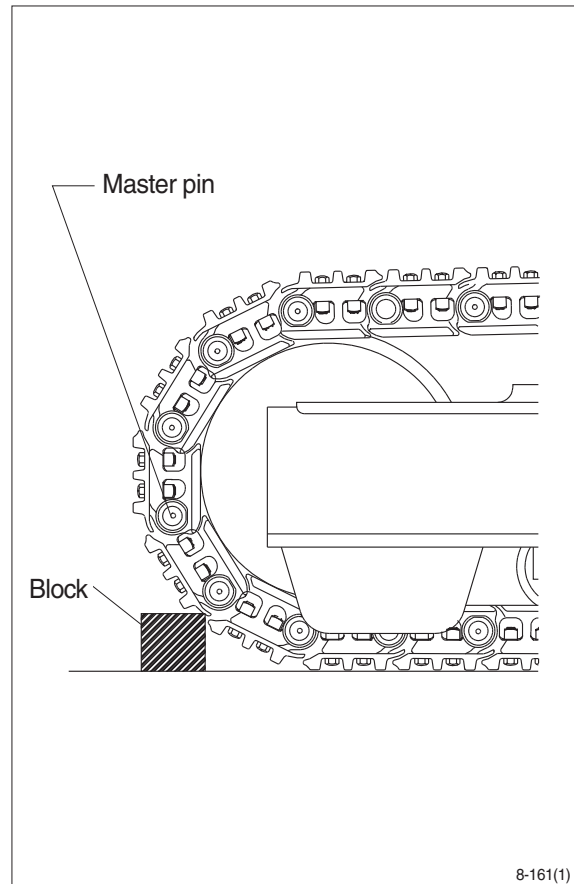

2) INSTALL

(1) Carry out installation in the reverse order to removal.

※ Adjust the tension of the track link.

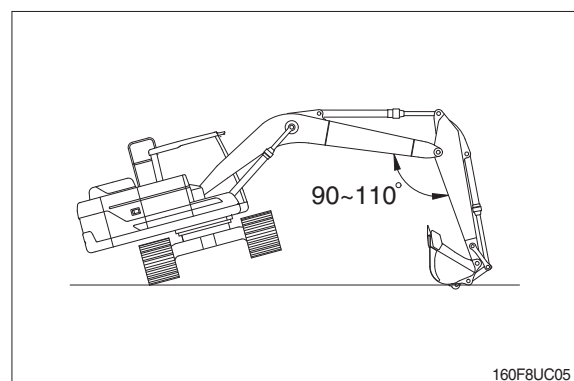

2. CARRIER ROLLER

1) REMOVAL

- (1) Loosen tension of the track link.

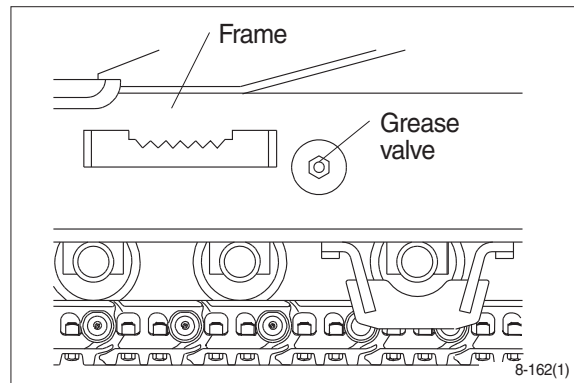

- (2) Jack up the track link height enough to permit carrier roller removal.

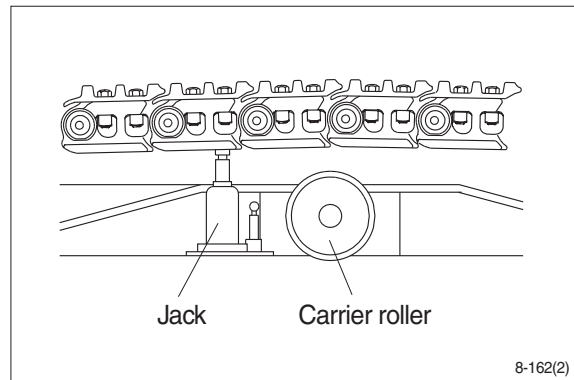

- (3) Loosen the lock nut (1).
- (4) Open bracket(2) with a screwdriver, push out from inside, and remove carrier roller assembly.
 - Weight : 20 kg (45 lb)

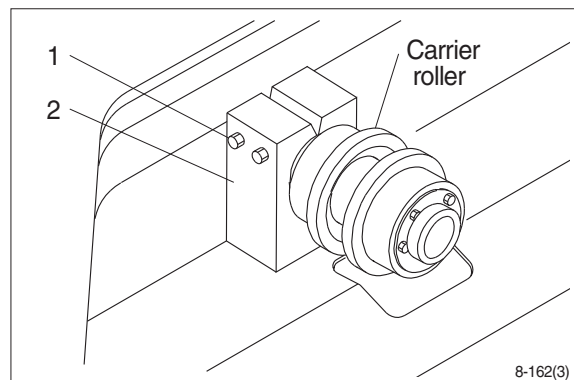

2) INSTALL

- (1) Carry out installation in the reverse order to removal.

3. TRACK ROLLER

1) REMOVAL

- (1) Loosen tension of the track link.

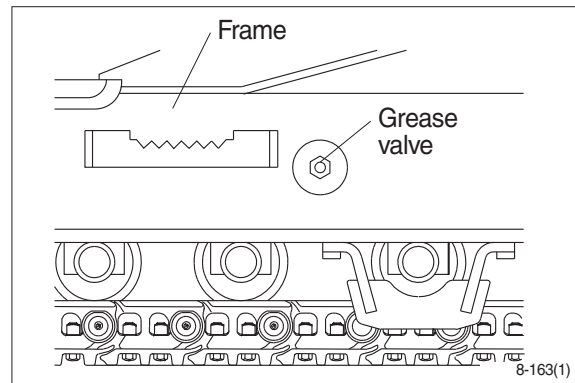

- (2) Using the work equipment, push up track frame on side which is to be removed.
※ After jack up the machine, set a block under the unit.

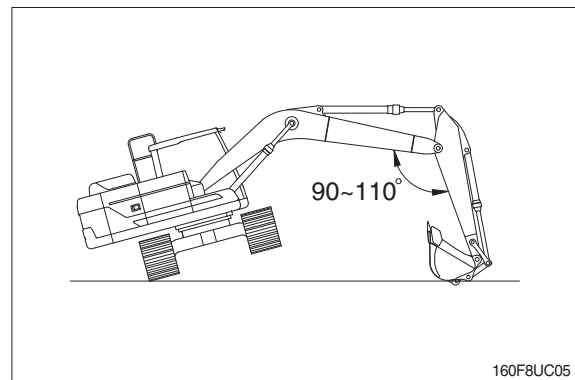

- (3) Remove the mounting bolt (1) and draw out the track roller (2).
· Weight : 45 kg (100 lb)

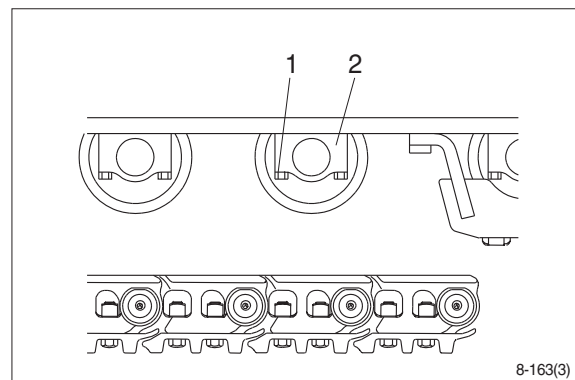

2) INSTALL

- (1) Carry out installation in the reverse order to removal.

4. IDLER AND RECOIL SPRING

1) REMOVAL

- (1) Remove the track link.
For detail, see removal of track link.

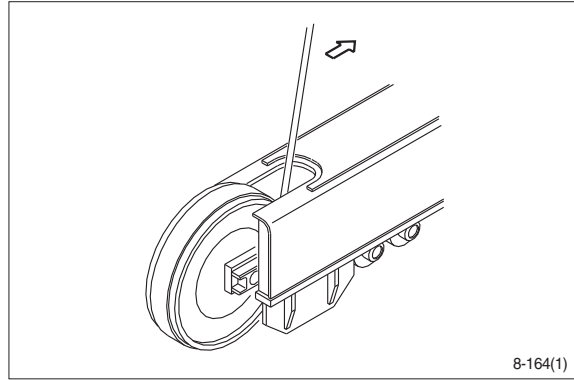

- (2) Sling the recoil spring (1) and pull out idler and recoil spring assembly from track frame, using a pry.
 - Weight : 300 kg (660 lb)

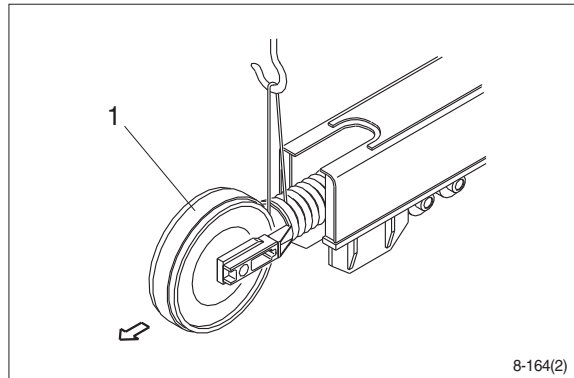

- (3) Remove the bolts (2), washers (3) and separate idler from recoil spring.

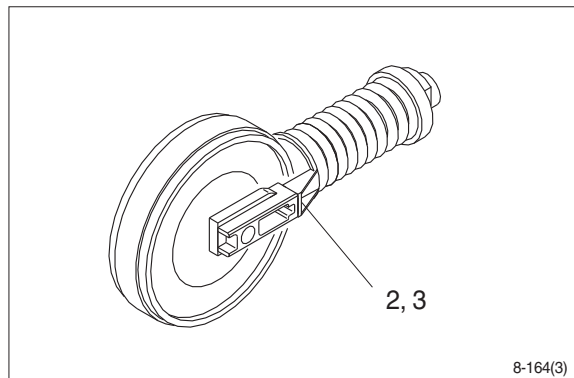

2) INSTALL

- (1) Carry out installation in the reverse order to removal.
 - ※ Make sure that the boss on the end face of the recoil cylinder rod is in the hole of the track frame.

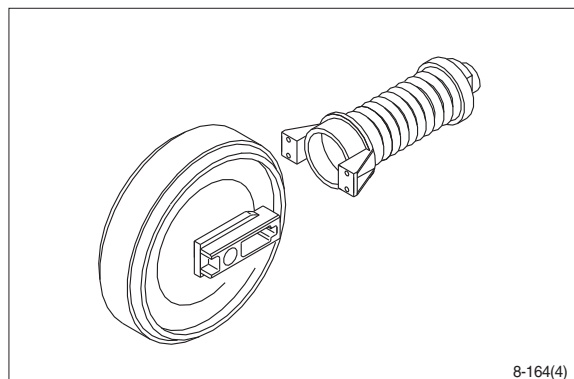

3) DISASSEMBLY AND ASSEMBLY OF IDLER

(1) Structure

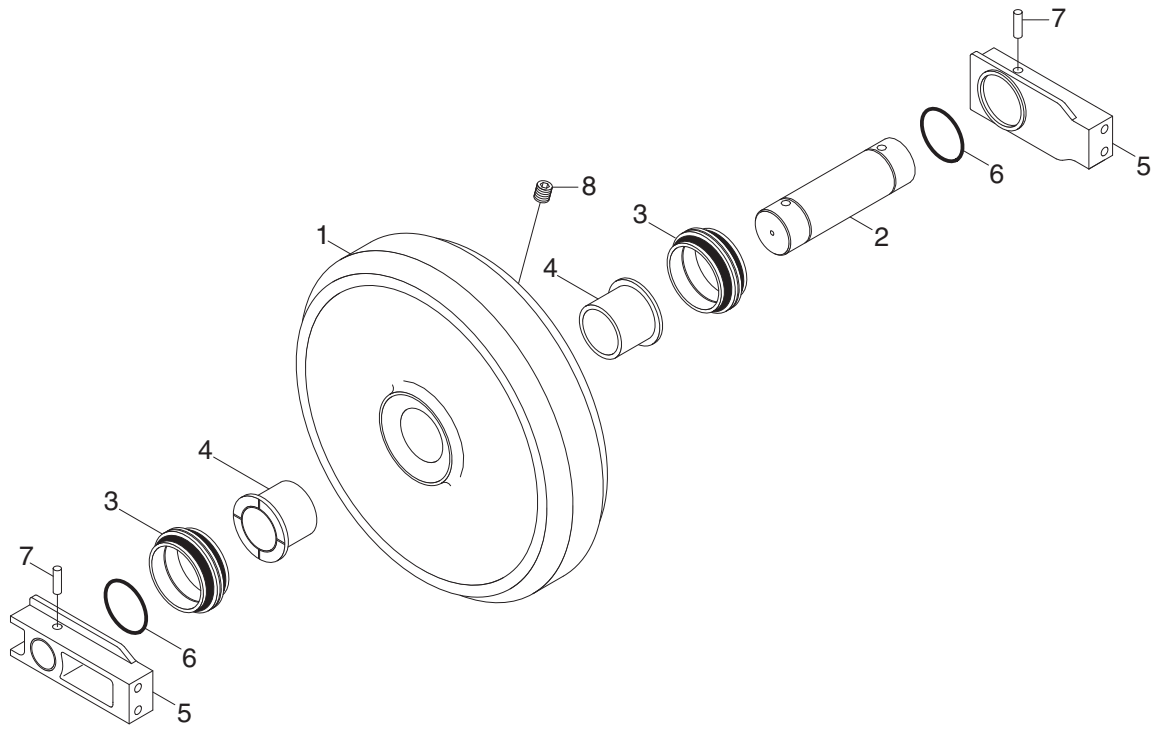

21078DA43

- 1 Shell
- 2 Shaft
- 3 Seal assembly

- 4 Bushing
- 5 Bracket
- 6 O-ring

- 7 Spring pin
- 8 Plug

(2) Disassembly

- ① Remove plug and drain oil.
- ② Draw out the spring pin (7), using a press.

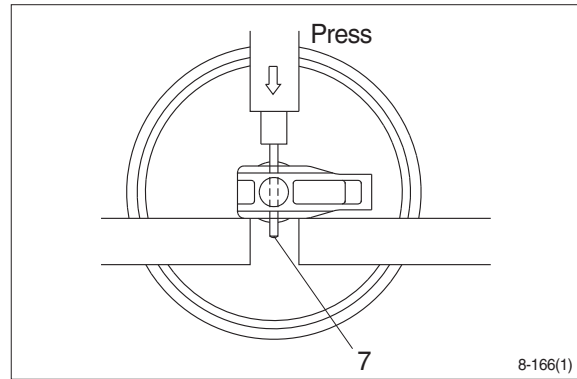

- ③ Pull out the shaft (2) with a press.
- ④ Remove seal (3) from idler (1) and bracket (5).
- ⑤ Remove O-ring (6) from shaft.

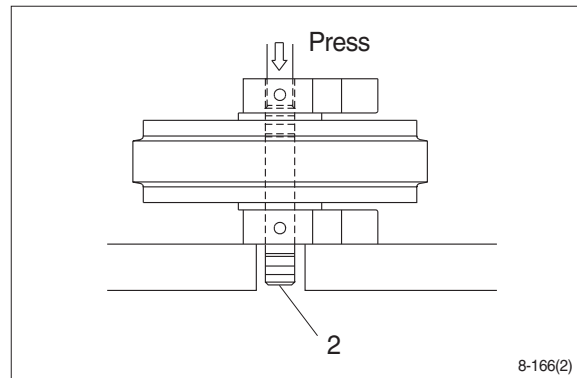

- ⑥ Remove the bushing (4) from idler, using a special tool. Only remove bushing if replacement is necessary.

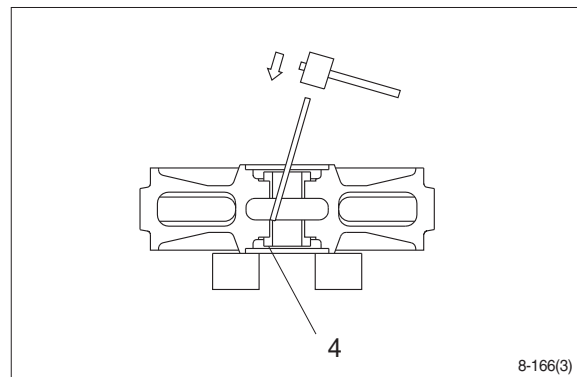

(3) Assembly

- ※ Before assembly, clean the parts.
- ※ Coat the sliding surfaces of all parts with oil.

① Cool up bushing (4) fully by some dry ice and press it into shell (1).

Do not press it at the normal temperature, or not knock in with a hammer even after the cooling.

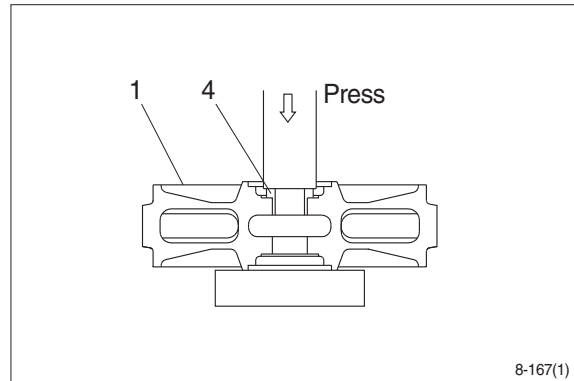

② Coat O-ring (6) with grease thinly, and install it to shaft (2).

③ Insert shaft (2) into bracket (5) and drive in the spring pin (7).

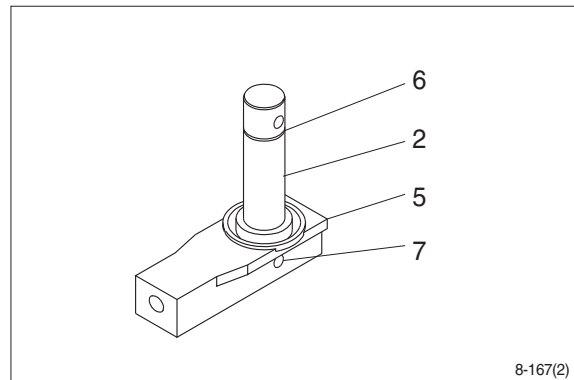

④ Install seal (3) to shell (1) and bracket (5).

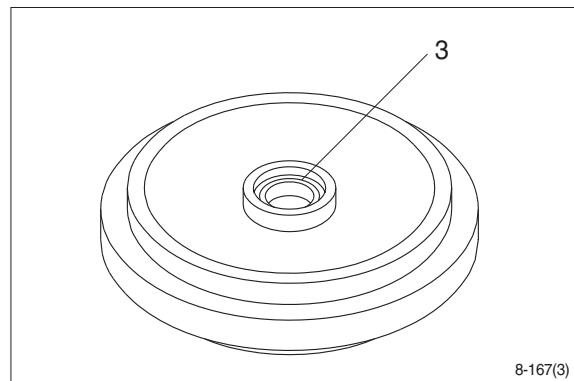

⑤ Install shaft (2) to shell (1).

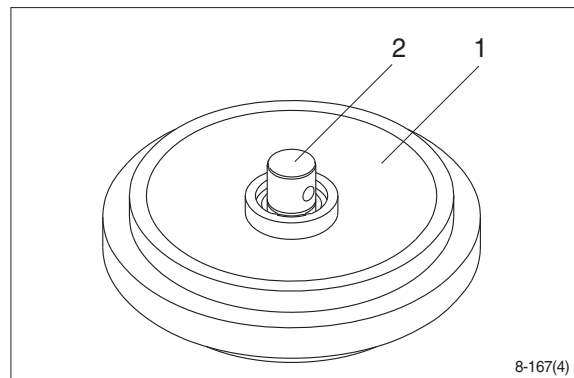

- ⑥ Install bracket (5) attached with seal (3).

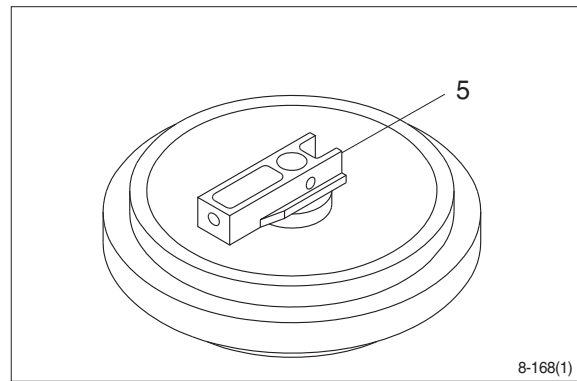

- ⑦ Knock in the spring pin (7) with a hammer.

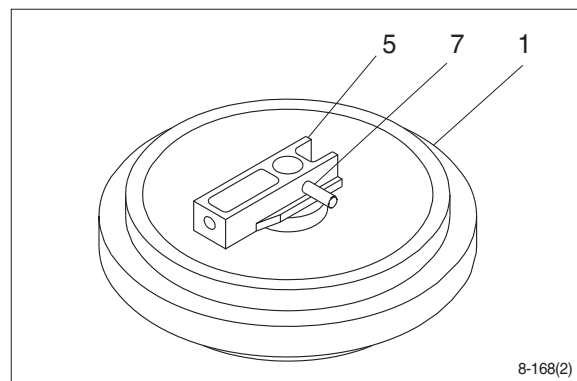

- ⑧ Lay bracket (5) on its side.
Supply engine oil to the specified level,
and tighten plug.

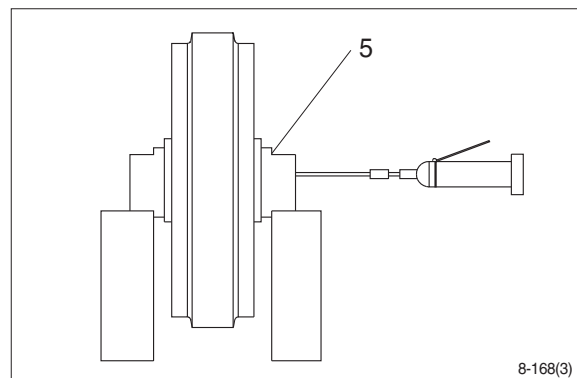

4) DISASSEMBLY AND ASSEMBLY OF RECOIL SPRING

(1) Structure

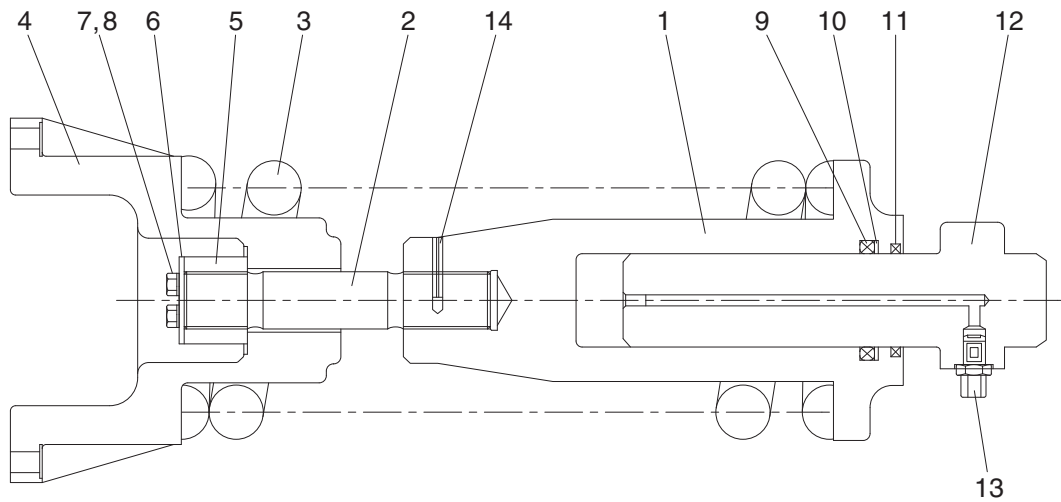

235ZF8UCG01

- | | | | | | |
|---|----------|----|---------------|----|--------------|
| 1 | Body | 6 | Lock plate | 11 | Dust seal |
| 2 | Tie bar | 7 | Bolt | 12 | Rod |
| 3 | Spring | 8 | Spring washer | 13 | Grease valve |
| 4 | Bracket | 9 | Rod packing | 14 | Spring pin |
| 5 | Lock nut | 10 | Back up ring | | |

(2) Disassembly

- ① Apply pressure on spring (3) with a press.
 - ※ The spring is under a large installed load. This is dangerous, so be sure to set properly.
 - Spring set load : 11908 kg (26253 lb)
- ② Remove bolt (7), spring washer (8) and lock plate (6).
- ③ Remove lock nut (5).

Take enough notice so that the press which pushes down the spring, should not be slipped out in its operation.
- ④ Lighten the press load slowly and remove bracket (4) and spring (3).

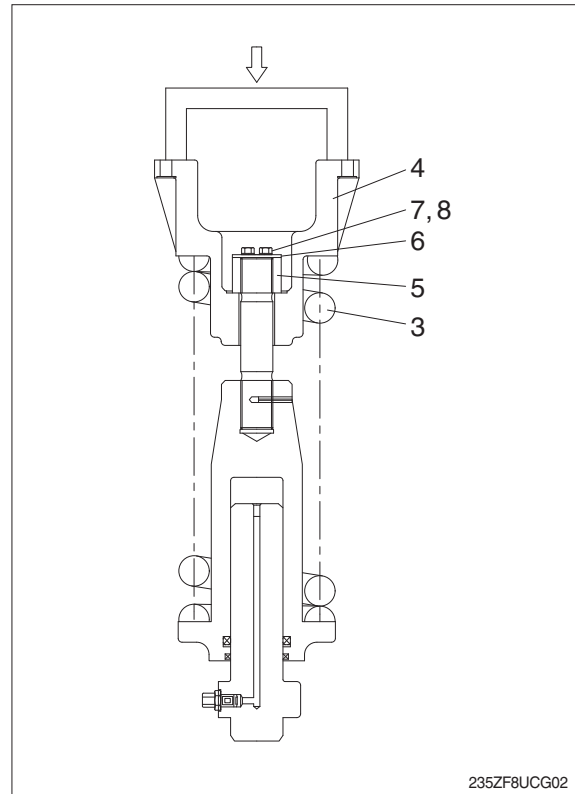

- ⑤ Remove rod (12) from body (1).
- ⑥ Remove grease valve (13) from rod (12).

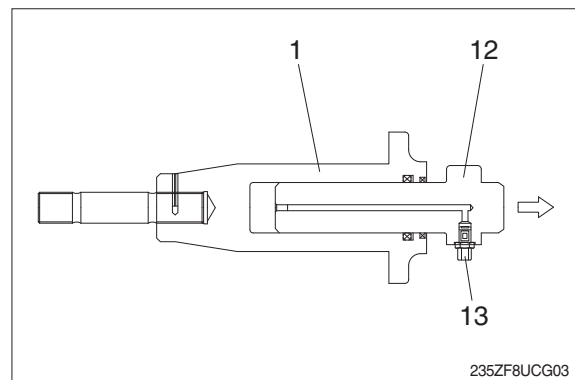

- ⑦ Remove rod packing (9), back up ring (10) and dust seal (11).

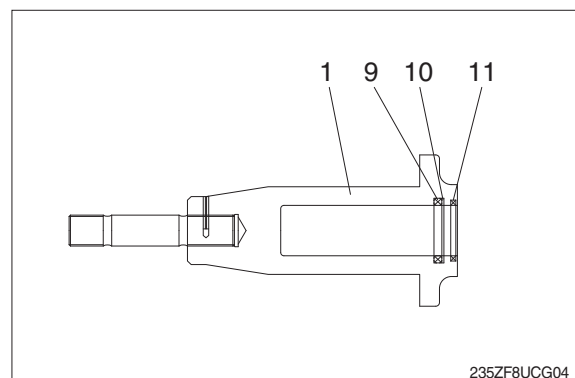

(3) Assembly

Install dust seal (11), back up ring (10) and rod packing (9) to body (1).

- ※ When installing dust seal (11) and rod packing (9), take full care so as not to damage the lip.

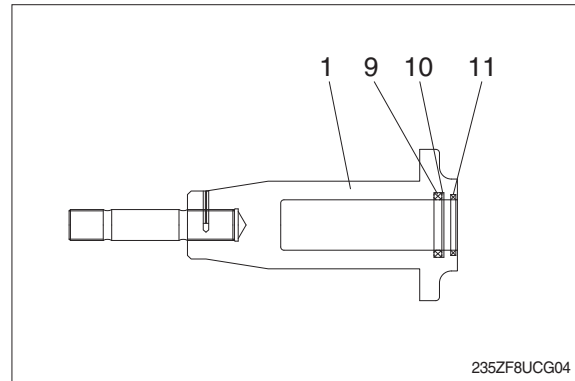

- ② Pour grease into body (1), then push in rod (12) by hand.

After take grease out of grease valve mounting hole, let air out.

- ※ If air letting is not sufficient, it may be difficult to adjust the tension of crawler.
- ③ Fit grease valve (13) to rod (12).
- Tightening torque : $13 \pm 1.0 \text{ kgf} \cdot \text{m}$
($94.0 \pm 7.2 \text{ lbf} \cdot \text{ft}$)

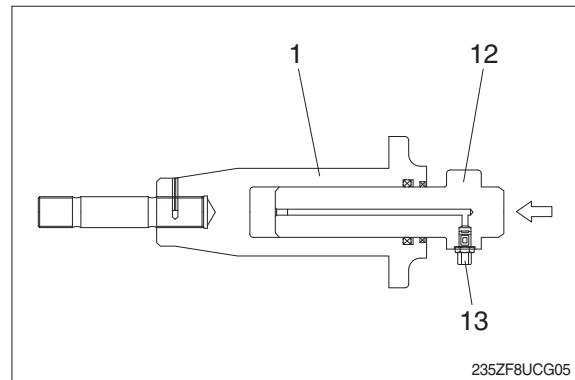

- ④ Install spring (3) and bracket (4) to body (1).

- ⑤ Apply pressure to spring (3) with a press and tighten lock nut (5).

- Tightening torque : $15 \pm 0.5 \text{ kgf} \cdot \text{m}$
($108 \pm 3.6 \text{ lbf} \cdot \text{ft}$)

- ※ Apply sealant before assembling.
- ※ During the operation, pay attention specially to prevent the press from slipping out.

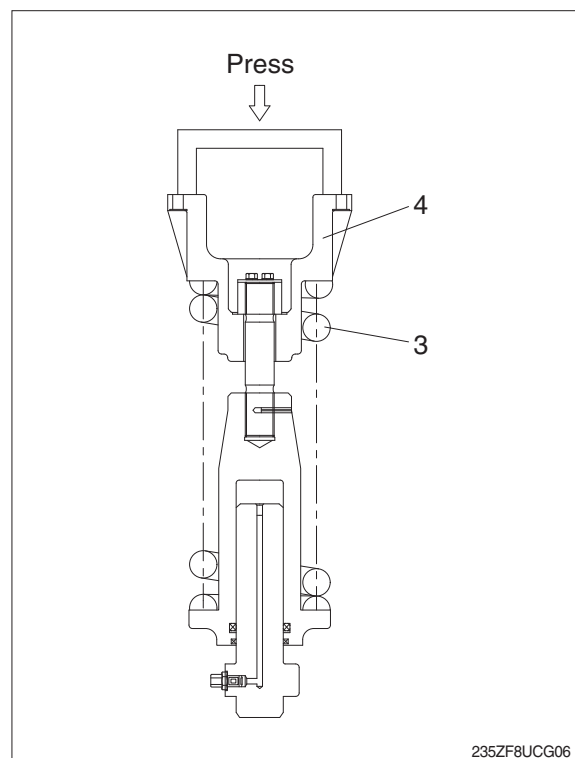

- ⑥ Lighten the press load and confirm the set length of spring (3).
- Spring install dimension : 420 ± 1.5 mm
(17 ± 0.06 in)
- ⑦ After the setting of spring (3), install lock plate (6), spring washer (8) and bolt (7).

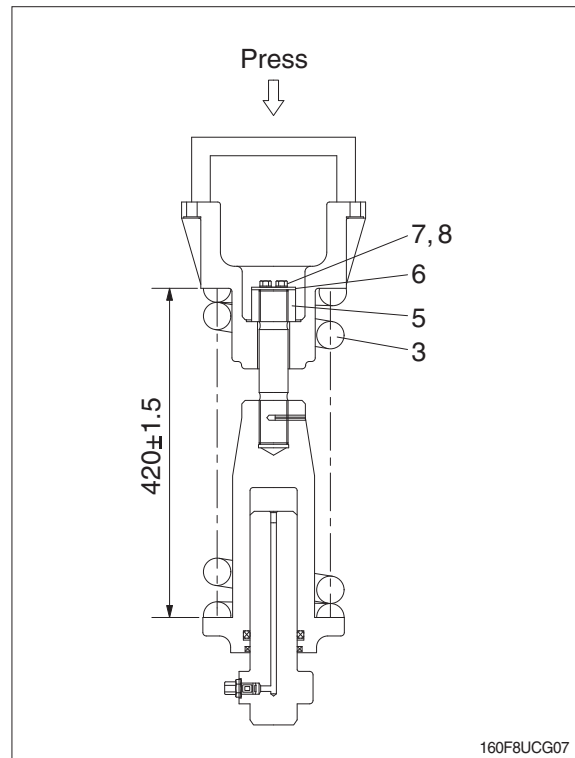

GROUP 11 WORK EQUIPMENT

1. STRUCTURE

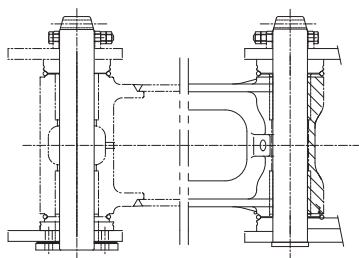
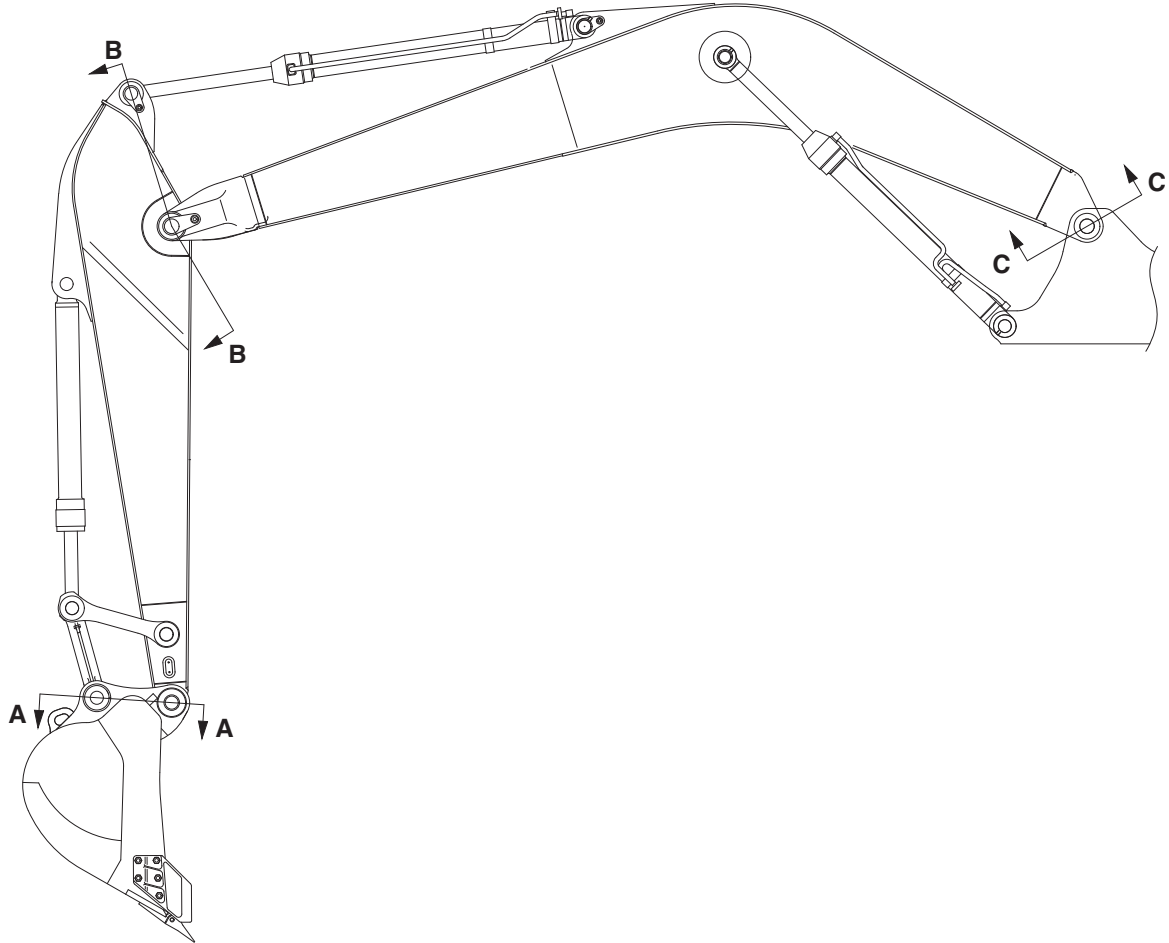

SECTION A

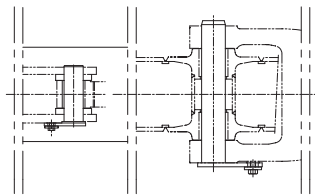

SECTION B

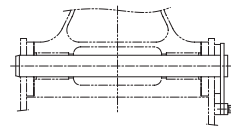

SECTION C

21078DA44

2. REMOVAL AND INSTALL

1) BUCKET ASSEMBLY

(1) Removal

- ① Lower the work equipment completely to ground with back of bucket facing down.

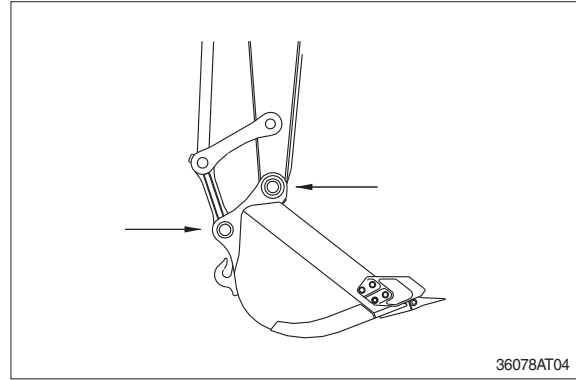

- ② Remove nut (1), bolt (2) and draw out the pin (B).

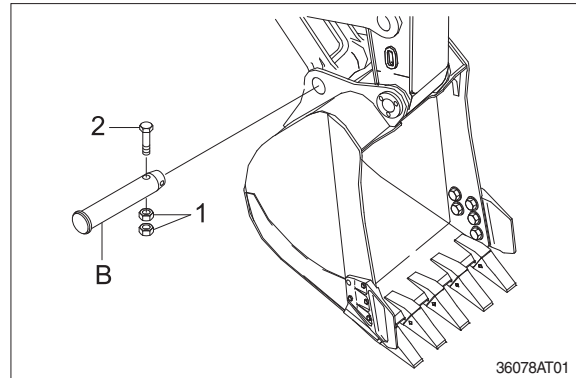

- ③ Remove nut (3), bolt (4) and draw out the pin (A) then remove the bucket assembly.

· Weight :

- 600 kg (1320 lb) : 0.70 m³ SAE heaped
- 620 kg (1370 lb) : 0.76 m³ SAE heaped

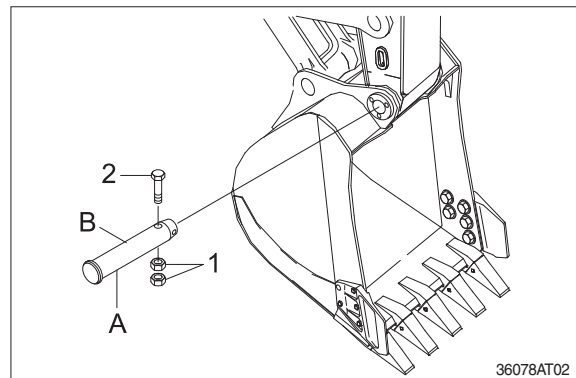

(2) Install

- ① Carry out installation in the reverse order to removal.

▲ When aligning the mounting position of the pin, do not insert your fingers in the pin hole.

- ※ Adjust the bucket clearance.
For detail, see operation manual.

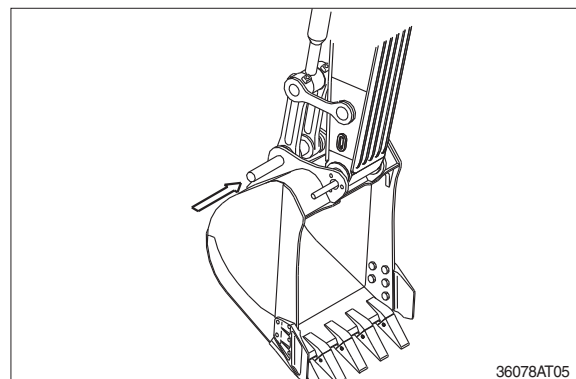

2) ARM ASSEMBLY

(1) Removal

※ Loosen the breather slowly to release the pressure inside the hydraulic tank.

▲ Escaping fluid under pressure can penetrate the skin causing serious injury.

① Remove bucket assembly.

For details, see removal of bucket assembly.

② Disconnect bucket cylinder hose (1).

▲ Fit blind plugs (5) in the piping at the chassis end securely to prevent oil from spurting out when the engine is started.

③ Sling arm cylinder assembly, remove spring, pin stopper and pull out pin.

※ Tie the rod with wire to prevent it from coming out.

④ For details, see removal of arm cylinder assembly.

Place a wooden block under the cylinder and bring the cylinder down to it.

⑤ Remove bolt (2), plate (3) and pull out the pin (4) then remove the arm assembly (2.6 m).

· Weight : 540 kg (1190 lb)

※ When lifting the arm assembly, always lift the center of gravity.

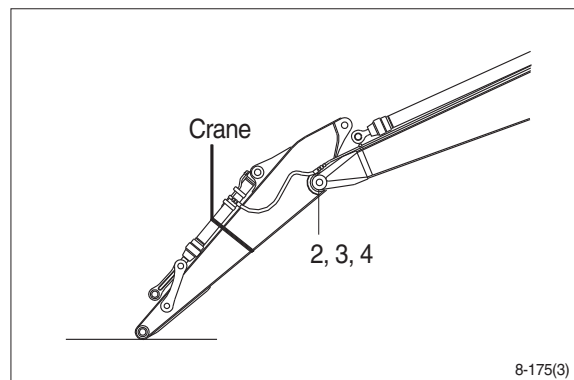
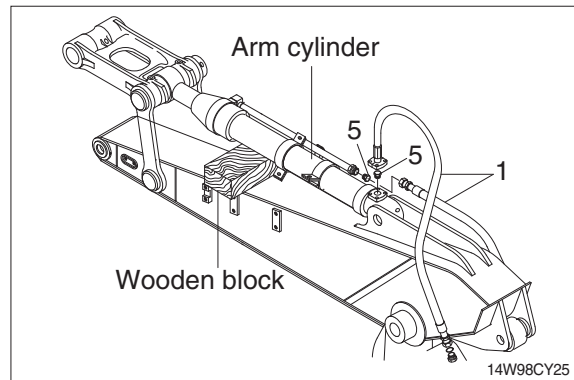
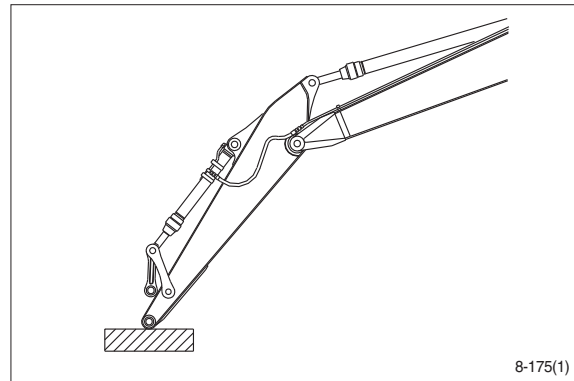

(2) Install

① Carry out installation in the reverse order to removal.

▲ When lifting the arm assembly, always lift the center of gravity.

※ Bleed the air from the cylinder.

3) BOOM CYLINDER

(1) Removal

- ① Remove arm and bucket assembly.
For details, see removal of arm and bucket assembly.
- ② Remove boom cylinder assembly from boom.
For details, see removal of arm cylinder assembly.

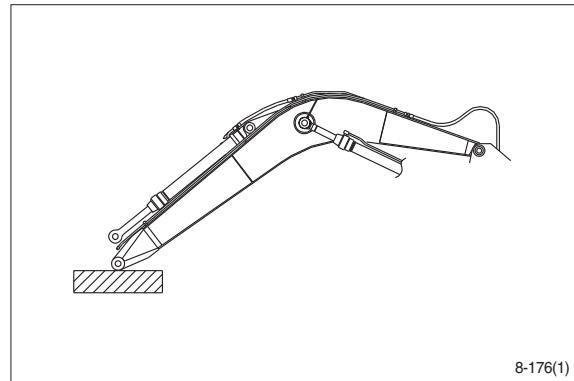

- ③ Disconnect head lamp wiring.
- ④ Disconnect bucket cylinder hose (2) and arm cylinder hose (1).
- ※ When the hose are disconnected, oil may spurt out.
- ⑤ Sling boom assembly (3).

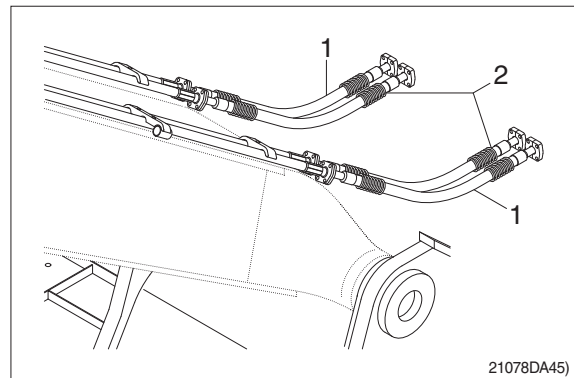

- ⑥ Remove bolt (4), plate (5) and pull out the pin (6) then remove boom assembly (5.1 m).
· Weight : 1060 kg (2340 lb)
- ※ When lifting the boom assembly always lift the center of gravity.

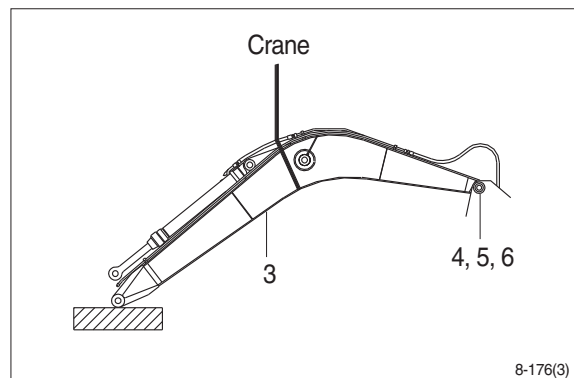

(2) Install

- ① Carry out installation in the reverse order to removal.
- ▲ When lifting the arm assembly, always lift the center of gravity.**
- ※ Bleed the air from the cylinder.

