

SECTION 2 STRUCTURE AND FUNCTION

Group 1 Pump Device	2-1
Group 2 Main Control Valve	2-20
Group 3 Swing Device	2-47
Group 4 Travel Device	2-50
Group 5 RCV Lever	2-63
Group 6 RCV Pedal	2-70

SECTION 2 STRUCTURE AND FUNCTION

GROUP 1 PUMP DEVICE

1. STRUCTURE

The pump device consists of main pump, regulator and gear pump.

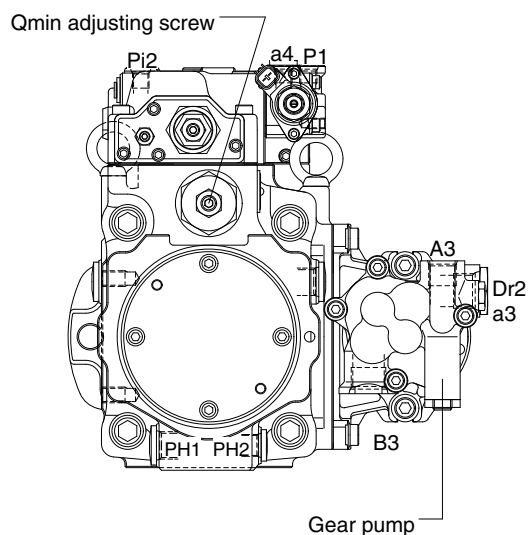
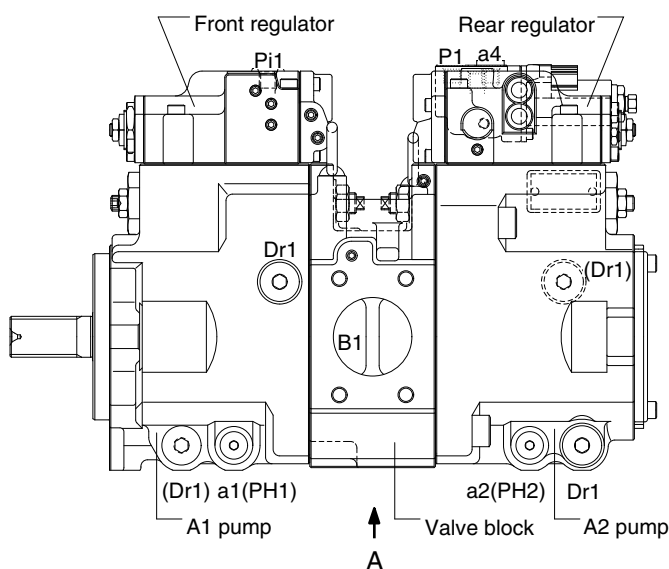
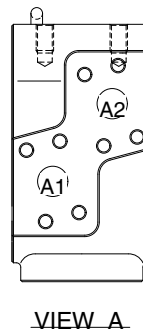
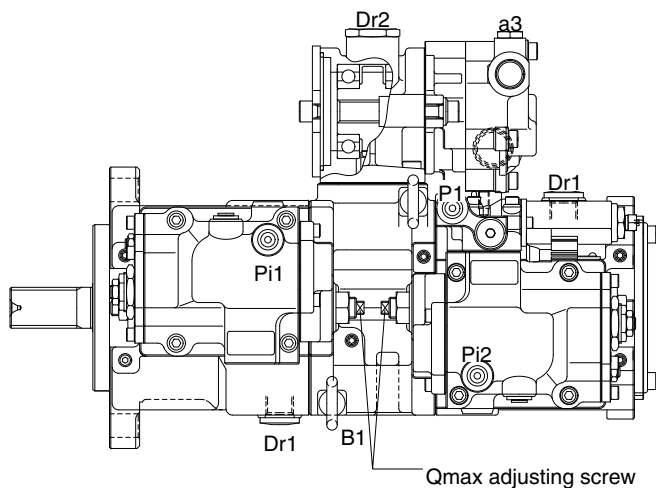

145LCR2MP01

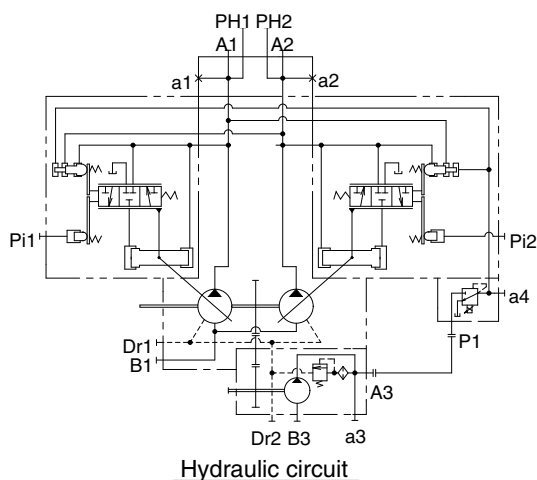

Port	Port name	Port size
A1, A2	Delivery port	SAE6000 psi 3/4"
B1	Suction port	SAE2500 psi 2 1/2"
Dr1	Drain port	PF 1/2 - 19
Dr2	Drain port	PF 3/4 - 20
Pi1, Pi2	Pilot port	PF 1/4 - 15
P1	EPPR port	PF 1/4 - 13
a1, a2	Gauge port	PF 1/4 - 15
a3	Gauge port	PF 1/4 - 14
PH1, PH2	Servo port	PF 3/8 - 17
a4	Gauge port	PF 1/4-13
A3	Gear pump delivery port	PF 1/2 - 19
B3	Gear pump suction port	PF 3/4 - 20.5

1) MAIN PUMP (1/2)

The main pump consists of two piston pumps (front & rear) and valve block.

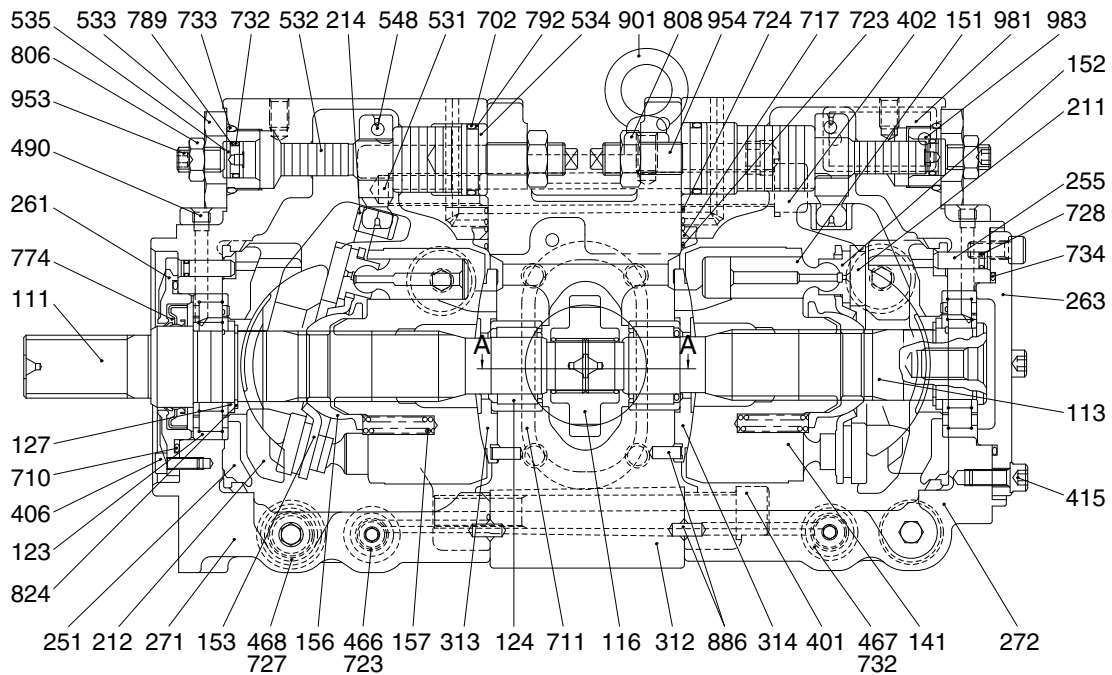

140Z92MP02

111	Drive shaft (F)	272	Pump casing (R)	711	O-ring
113	Drive shaft (R)	312	Valve block	717	O-ring
116	1st Gear	313	Valve plate (R)	723	O-ring
123	Roller bearing	314	Valve plate (L)	724	O-ring
124	Needle bearing	401	Hexagon socket bolt	728	O-ring
127	Bearing spacer	402	Hexagon socket bolt	732	O-ring
141	Cylinder block	406	Hexagon socket bolt	733	O-ring
151	Piston	415	Hexagon socket bolt	734	O-ring
152	Shoe	466	Plug	774	Oil seal
153	Set plate	467	plug	789	Back up ring
156	Bushing	468	Plug	792	Back up ring
157	Cylinder spring	490	Plug	806	Nut
211	Shoe plate	531	Tilting pin	808	Hexagon head nut
212	Swash plate	532	Servo piston	824	Snap ring
214	Bushing	533	Plug	886	Spring pin
251	Support	534	Stopper (L)	901	Eye bolt
255	Lock pin	535	Stopper (S)	953	Set screw
261	Seal cover (F)	548	Pin	954	Set screw
263	Seal cover (R)	702	O-ring	981	Plate
271	Pump casing (F)	710	O-ring	983	Pin

MAIN PUMP (2/2)

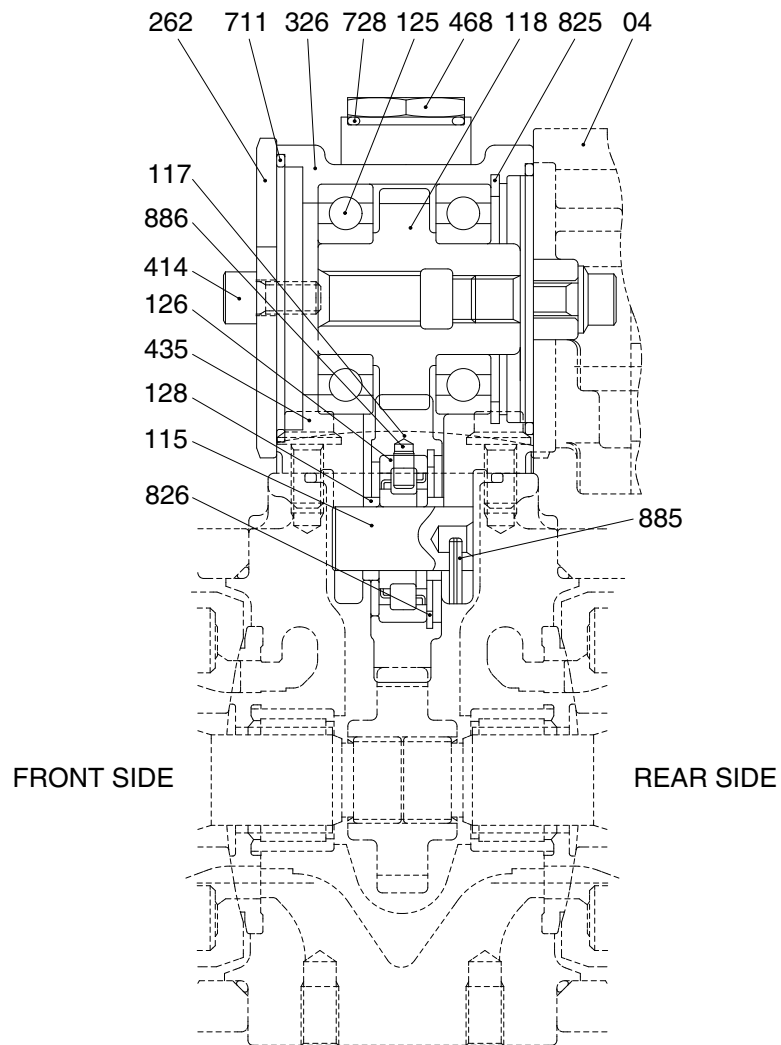

140Z92MP03

04	Gear pump	128	Bearing spacer	711	O-ring
115	Shaft	262	Cover	728	O-ring
117	Gear No. 2	326	Gear case	825	Retainer ring
118	Gear No. 3	414	Hexagon socket bolt	826	Retainer ring
125	Ball bearing	435	Flange socket bolt	885	Spring pin
126	Roller bearing	468	Plug	886	Pin

2) REGULATOR (1/2)

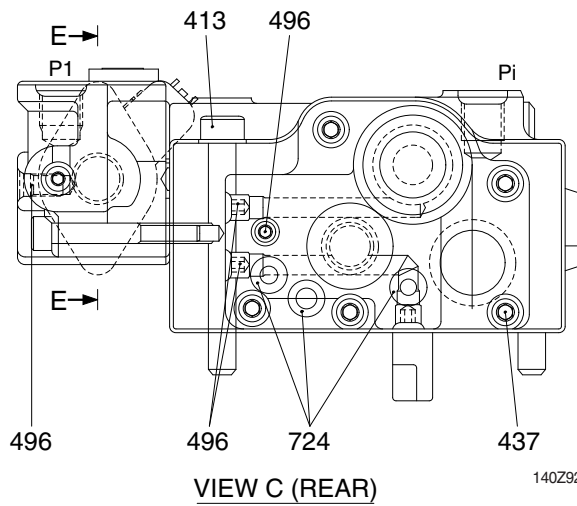
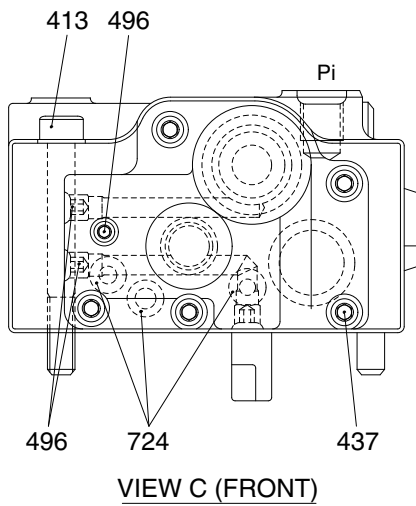
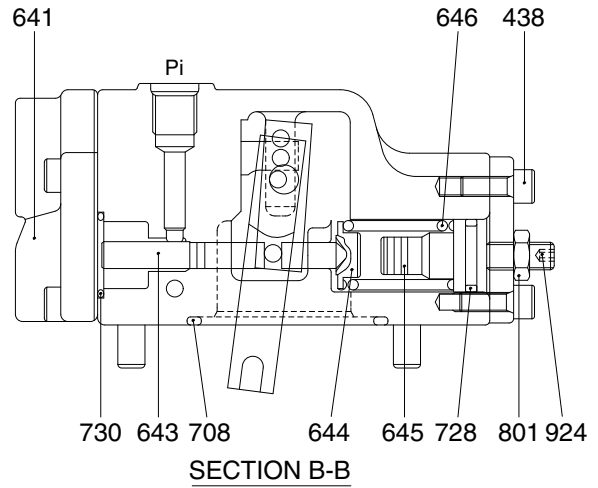
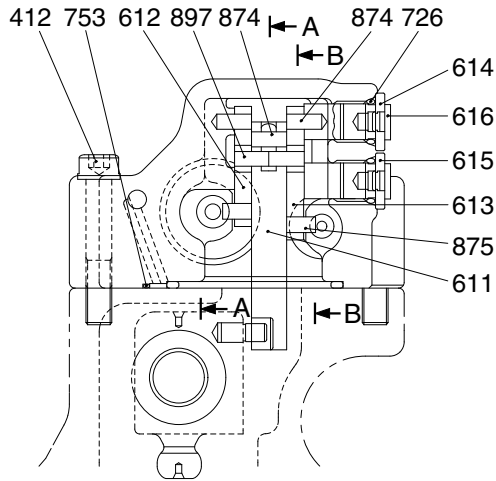

140Z92MP04

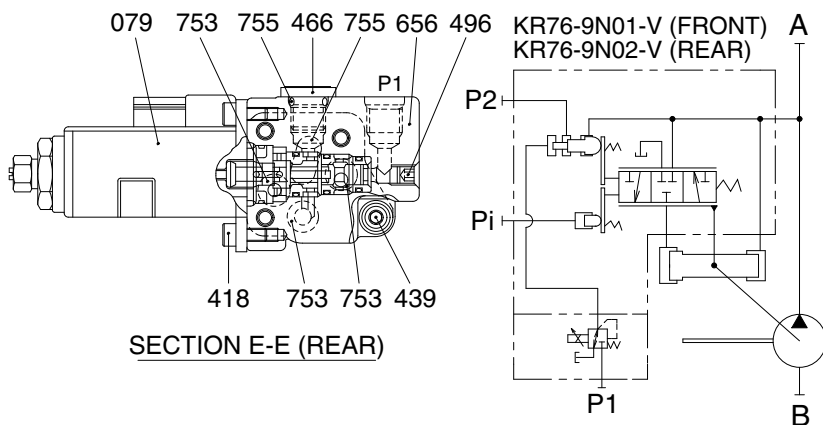

Port	Port name	Port size
A	Delivery port	SAE6000 psi 3/4"
B	Suction port	SAE2500 psi 2 1/2"
Pi	Pilot port	PF 1/4-15
P1	EPPR valve primary port	PF 1/4-13
P2	Companion delivery port	internal

REGULATOR (2/2)

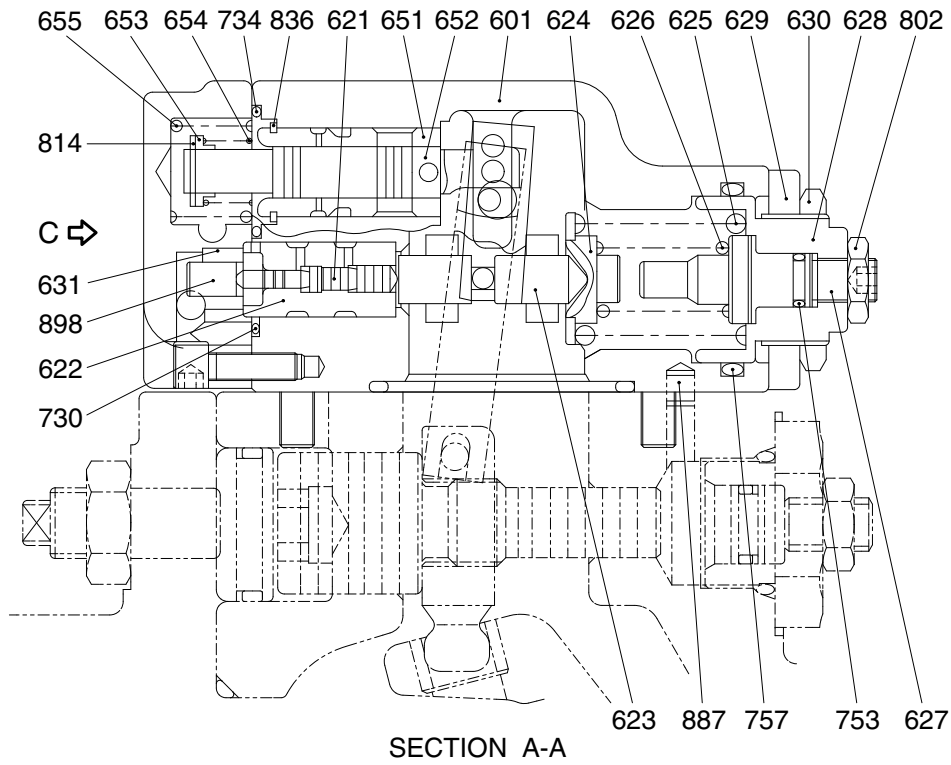

140Z92MP05

079	EPPR valve assembly	624	Spring seat (C)	708	O-ring
412	Hexagon socket screw	625	Outer spring	724	O-ring
413	Hexagon socket screw	626	Inner spring	725	O-ring
418	Hexagon socket screw	627	Adjust stem (C)	728	O-ring
437	Hexagon socket screw	628	Adjust screw (C)	730	O-ring
438	Hexagon socket screw	629	Cover (C)	734	O-ring
439	Hexagon socket screw	630	Lock nut	753	O-ring
466	Plug	631	Sleeve, Pf	755	O-ring
496	Plug	641	Pilot cover	757	O-ring
601	Casing	643	Pilot piston	801	Nut
611	Feed back lever	644	Spring seat (Q)	802	Nut
612	Lever 1	645	Adjust stem (Q)	814	Snap ring
613	Lever 2	646	Pilot spring	836	Snap ring
614	Center plug	651	Sleeve	874	Pin
615	Adjust plug	652	Spool	875	Pin
616	Plug	653	Spring seat	887	Pin
621	Compensator piston	654	Return spring	897	Pin
622	Piston case	655	Set spring	898	Pin
623	Compensator rod	656	Block cover	924	Set screw

3) GEAR PUMP

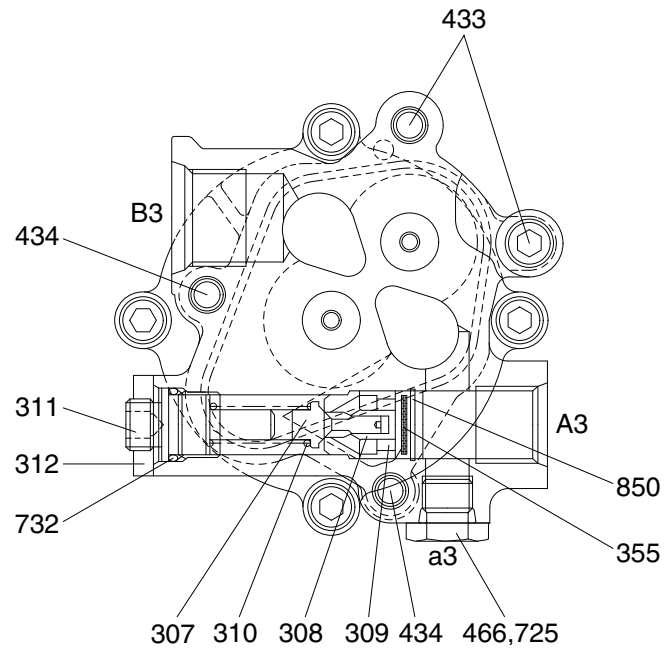
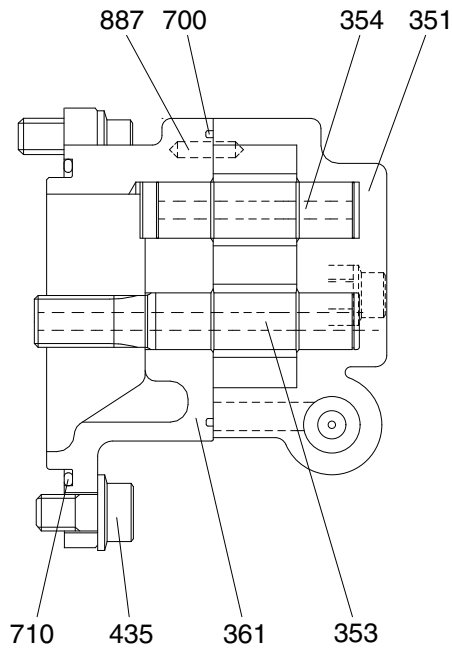

14092MP06

307 Poppet
 308 Seat
 309 Ring
 310 Spring
 311 Screw
 312 Nut
 351 Gear case

353 Drive gear
 354 Driven gear
 355 Filter
 361 Front case
 433 Flange socket
 434 Flange socket
 435 Flange socket

466 Plug
 700 Ring
 710 O-ring
 725 O-ring
 732 O-ring
 850 Snap ring
 887 Pin

2. FUNCTION

1) MAIN PUMP

The pumps may be classified roughly into the rotary group performing a rotary motion and working as the major part of the whole pump function: the swash plate group that varies the delivery rates: and the valve cover group that changes over oil suction and discharge : and the PTO group that transfers drive shaft of gear pump.

(1) Rotary group

The rotary group consists of drive shaft (F) (111), cylinder block (141), piston shoes (151,152), set plate (153), spherical bushing (156) and cylinder spring (157). The drive shaft is supported by bearing (123,124) at its both ends.

The shoe is caulked to the piston to form a spherical coupling. It has a pocket to relieve thrust force generated by loading pressure and to take hydraulic balance so that it slides lightly over the shoe plate (211). The sub group composed by a piston and a shoe is pressed against the shoe plate by the action of the cylinder spring via the set plate and a spherical bushing.

Similarly, the cylinder block is pressed against valve plate (313) by the action of the cylinder spring.

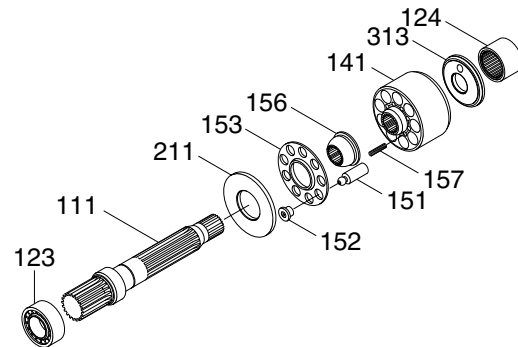

21092MP06

(2) Swash plate group

The swash plate group consists of swash plate (212), shoe plate (211), swash plate support (251), lock pin (255), tilting bushing (214), tilting pin (531) and servo piston (532).

The swash plate is a cylindrical part formed on the opposite side of the sliding surface of the shoe and is supported by the swash support.

If the servo piston moves to the right or left as hydraulic force controlled by the regulator connects to hydraulic chamber located on both sides of the servo piston, the swash plate slides over the swash plate support via the spherical part of the tilting pin to change the tilting angle (α)

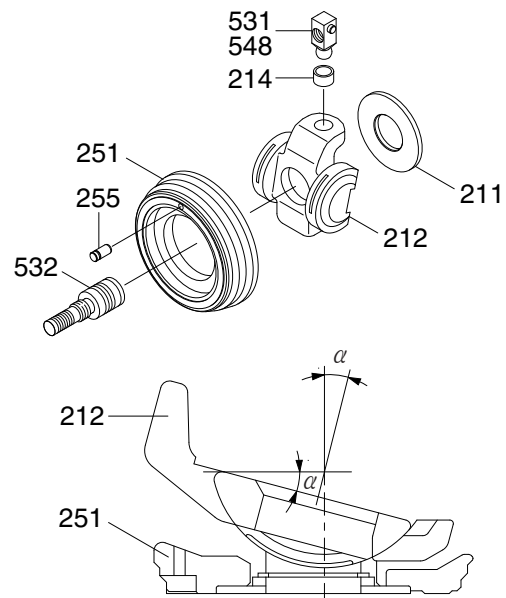

140Z92MP09

(3) Valve block group

The valve block group consists of valve block (312), valve plate (313, 314) and spring pin(886).

The valve plate having two kidney ports is fixed to the valve block and feeds and collects oil to and from the cylinder block.

The oil changed over by the valve plate is connected to an external pipeline by way of the valve block.

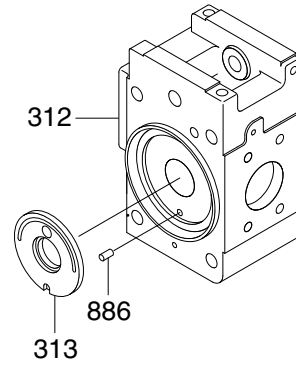

140Z92MP07

(4) PTO group

PTO group consist of 1st gear (116) and 2nd gear (117), 3rd gear (118).

2nd gear and 3rd gear are supported by bearings (125, 126), and it can be mounted to the valve block.

Now, if the drive shaft is driven by a prime mover (electric motor, engine, etc), it rotates the cylinder block via a spline linkage at the same time. If the swash plate is tilted as in Fig (previous page) the pistons arranged in the cylinder block make a reciprocating motion with respect to the cylinder block, while they revolve with the cylinder block.

If you pay attention to a single piston, it performs a motion away from the valve plate (oil sucking process) within 180 degrees, and makes a motion towards the valve plate (oil discharging process) in the rest of 180 degrees. When the swash plate has a tilting angle of zero, the piston makes no stroke and discharges no oil.

Concurrently, the auxiliary pump is driven by gears of PTO.

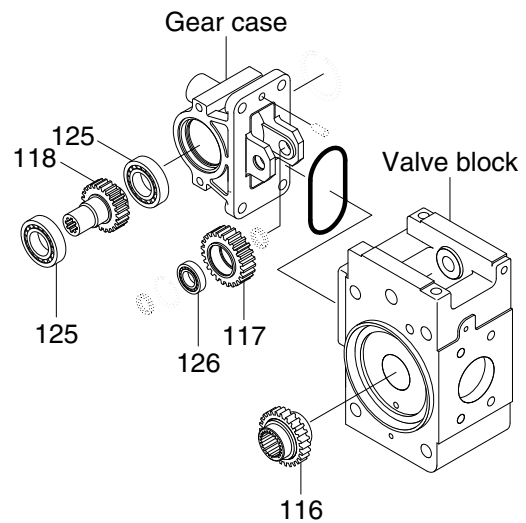

140Z92MP08

2) REGULATOR

Regulator consists of the negative flow control, total horse power control and power shift control function.

(1) Negative flow control

By changing the pilot pressure P_i , the pump tilting angle (delivery flow) is regulated arbitrarily, as shown in the figure.

This regulator is of the negative flow control in which the delivery flow Q decreases as the pilot pressure P_i rises.

With this mechanism, when the pilot pressure corresponding to the flow required for the work is commanded, the pump discharges the required flow only, and so it does not consume the power uselessly.

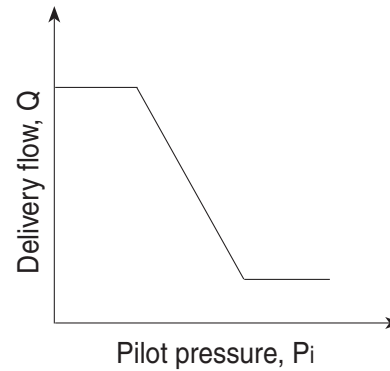

① Flow reducing function

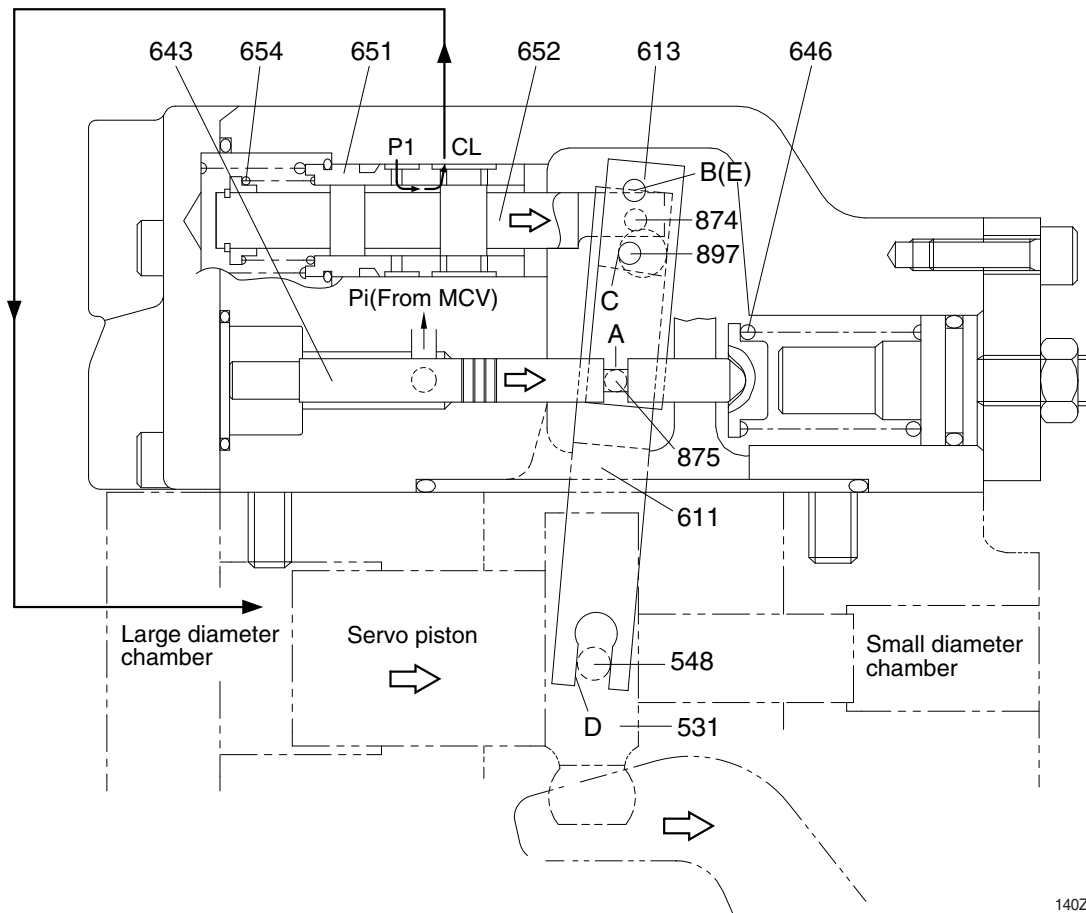

140Z92MP12

As the pilot pressure P_i rises, the pilot piston (643) moves to the right to a position where the force of the pilot spring (646) balances with the hydraulic force.

The groove (A) in the pilot piston is fitted with the pin (875) that is fixed to lever 2 (613). Therefore, when the pilot piston moves, lever 2 rotates around the fulcrum of point B [fixed by the fulcrum plug (614) and pin (875)]. Since the large hole section (C) of lever 2 contains a protruding pin (897) fixed to the feedback lever (611), the pin (897) moves to the right as lever 2 rotates. Since the opposing-flat section (D) of the feedback lever is fitted with the pin (548) fixed by the tilting pin (531) that swings the swash plate, the feedback lever rotates around the fulcrum of point D, as the pin (897) moves.

Since the feedback lever is connected with the spool (652) via the pin (874), the spool moves to the right.

The movement of the spool causes the delivery pressure P_1 to connect to port CL through the spool and to be admitted to the large diameter section of the servo piston. The delivery pressure P_1 that is constantly admitted to the small diameter section of the servo piston moves the servo piston to the right due to the area difference, resulting in decrease of the tilting angle.

When the servo piston moves to the right, point D also moves to the right. The spool is fitted with the return spring (654) and is tensioned to the left at all times, and so the pin (897) is pressed against the large hole section (C) of lever 2.

Therefore, as point D moves, the feedback lever rotates around the fulcrum of point C, and the spool is shifted to the left. This causes the opening between the sleeve (651) and spool (652) to close slowly, and the servo piston comes to a complete stop when it closes completely.

② Flow increasing function

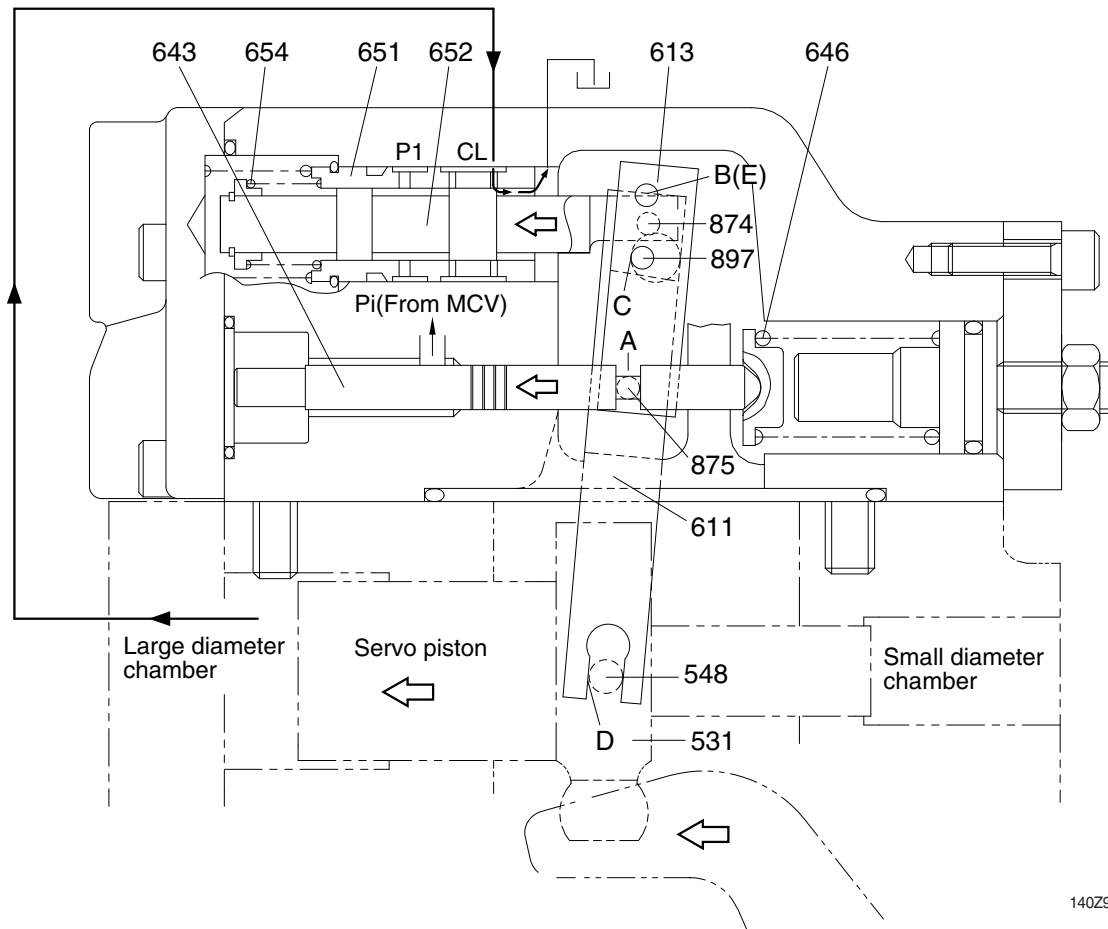

140Z92MP13

As the pilot pressure P_i decreases, the pilot piston (643) moves to the left by the action of the pilot spring (646) and causes lever 2 (613) to rotate around the fulcrum of point B. Since the pin (897) is pressed against the large hole section (C) of lever 2 by the action of the return spring (654) via the spool (652), pin (874), and feedback lever (611), the feedback lever rotates around the fulcrum of point D as lever 2 rotates, and shifts the spool to the left. Port CL opens a way to the tank port as the spool moves. This deprives the large diameter section of the servo piston of pressure, and shifts the servo piston to the left by the discharge pressure P1 in the small diameter section, resulting in an increase in the flow rate.

As the servo piston moves, point D also moves to the left, the feedback lever rotates around the fulcrum of point C, and the spool moves to the right till the opening between the spool and sleeve is closed.

③ Adjustment of flow control characteristic

The flow control characteristic can be adjusted with the adjusting screw.

Adjust it by loosening the hexagon nut (801) and by tightening (or loosening) the hexagonal socket head screw (924).

Tightening the screw shifts the control chart to the right as shown in the figure.

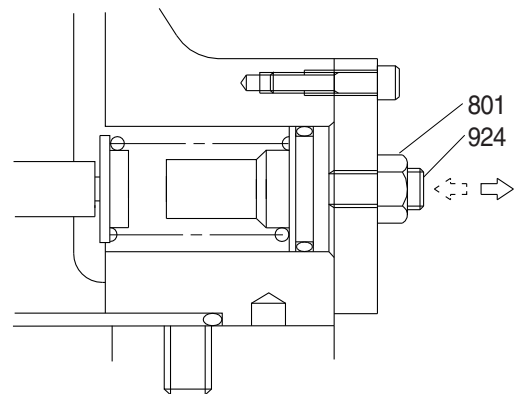

※ Adjusting value

Speed	Adjustment of flow control characteristic		
	Tightening amount of adjusting screw (924)	Flow control starting pressure change amount	Flow change amount
(min ⁻¹)	(Turn)	(kgf/cm ²)	(ℓ/min)
1900	+1/4	+1.4	+7.1

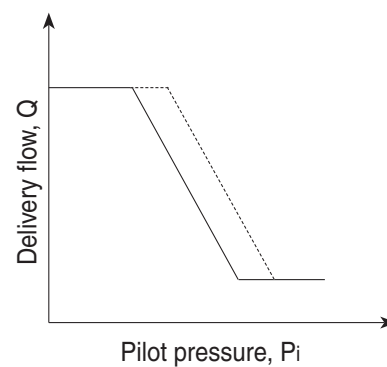

(2) Total horsepower control

The regulator decreases the pump tilting angle (delivery flow) automatically to limit the input torque within a certain value with a rise in the delivery pressure P_1 of the self pump and the delivery pressure P_2 of the companion pump.

(The input horsepower is constant when the speed is constant.)

Since the regulator is of the simultaneous total horsepower type that operates by the sum of load pressures of the two pumps in the tandem double-pump system, the prime mover is automatically prevented from being overloaded, irrespective of the load condition of the two pumps, when horsepower control is under way.

Since this regulator is of the simultaneous total horsepower type, it controls the tilting angles (displacement volumes) of the two pumps to the same value as represented by the following equation :

$$\begin{aligned} T_{in} &= P_1 \times q/2J + P_2 \times q/2J \\ &= (P_1+P_2) \times q/2J \end{aligned}$$

The horsepower control function is the same as the flow control function and is summarized in the following. (For detailed behaviors of respective parts, refer to the section of flow control).

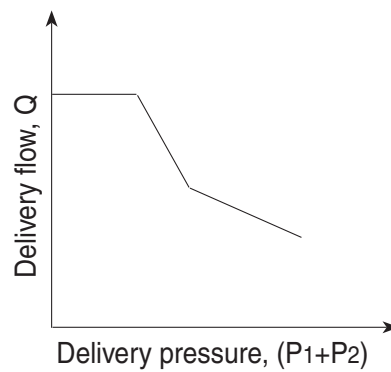

① Overload preventive function

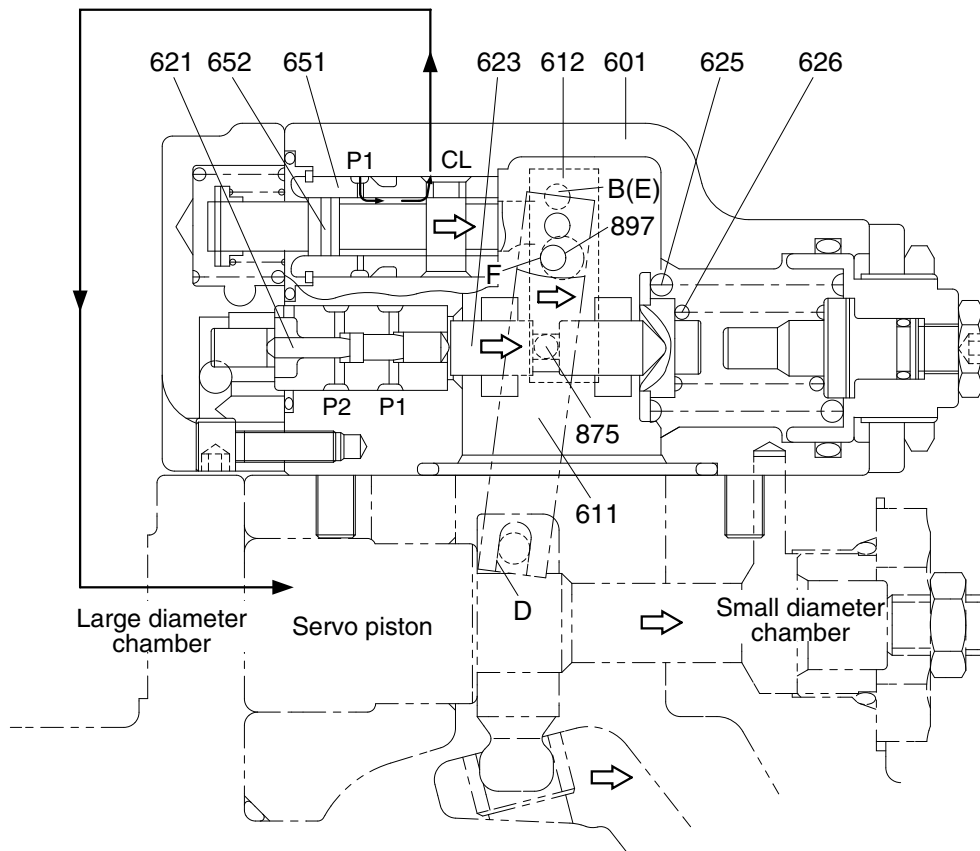

140Z92RG03

When the self pump delivery pressure P1 or the companion pump delivery pressure P2 rises, it acts on the stepped part of the compensating piston (621). It presses the compensating rod (623) to the right till the force of the outer spring (625) and inner spring (626) balances with the hydraulic force. The movement of the compensating rod is transmitted to lever 1 (612) via pin (875).

Lever 1 rotates around the pin (875) (E) fixed to the casing (601).

Since the large hole section (F) of lever 1 contains a protruding pin (897) fixed to the feedback lever (611), the feedback lever rotates around the fulcrum of point D as lever 1 rotates, and then the spool (652) is shifted to the right. As the spool moves, the delivery pressure P1 is admitted to the large diameter section of the servo piston via port CL, causes the servo piston move to the right, reduces the pump delivery, flow rate, and prevents the prime mover from being overloaded. The movement of the servo piston is transmitted to the feedback lever via point D. Then the feedback lever rotates around the fulcrum of point F and the spool is shifted to the left. The spool moves till the opening between the spool (652) and sleeve (651) is closed.

② Flow reset function

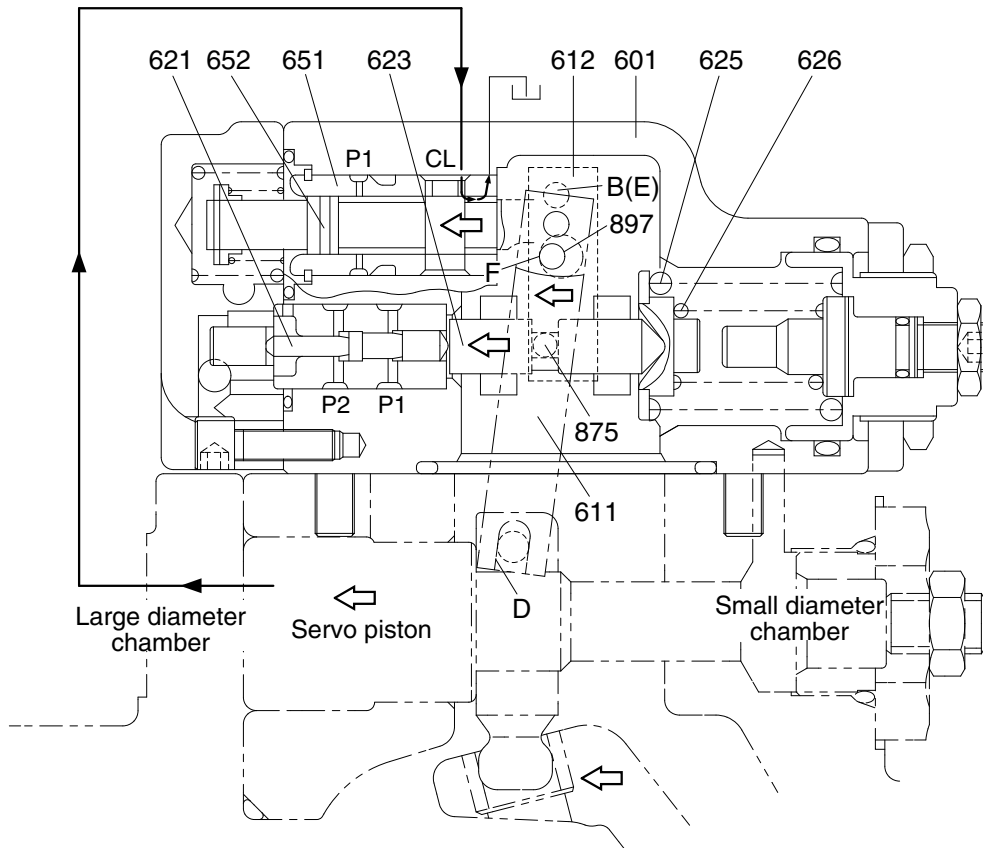

140Z92RG04

As the self pump delivery pressure P1 or the companion pump delivery pressure P2 decreases, the compensating rod (623) is pushed back by the action of the springs (625 & 626) to rotate lever 1 (612) around point E. Rotating of lever 1 causes the feedback lever (611) to rotate around the fulcrum of point D and then the spool (652) to move to the left. As a result, port CL opens a way to the tank port.

This causes the servo piston to move to the left and the pump's delivery rate to increase.

The movement of the servo piston is transmitted to the spool by the action of the feedback mechanism to move it till the opening between the spool and sleeve is closed.

③ **Low tilting angle (low flow) command preferential function**

As mentioned above, flow control and horsepower control tilting angle commands are transmitted to the feedback lever and spool via the large-hole sections (C & F) of levers 1 and 2. However, since sections C and F have the pins ($\varnothing 4$) protruding from the large hole ($\varnothing 8$), only the lever lessening the tilting angle contacts the pin (897) ; the hole ($\varnothing 8$) in the lever of a larger tilting angle command is freed without contacting the pin (897). Such a mechanical selection method permits preference of the lower tilting angle command of the flow control and horsepower control.

④ **Adjustment of input horsepower**

Since the regulator is of total cumulative horsepower type, adjust the adjusting screws of both the front and rear pumps, when changing the horsepower set values. The pressure change values by adjustment are based on two pumps pressurized at the same time, and the values will be doubled when only one pump is loaded.

a. **Adjustment of outer spring**

Adjust it by loosening the hexagon nut (630) and by tightening (or loosening) the adjusting screw C (628).

Tightening the screw shifts the control chart to the right and increases the input horsepower as shown in the figure. Since turning the adjusting screw C (628) by N turns changes the setting of the inner spring (626), return the adjusting stem C (627) by $N \times A$ turns at first. ($A=1.48$)

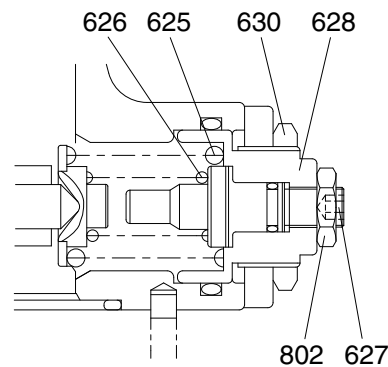

140Z92RG07

※ **Adjusting value**

Speed (min ⁻¹)	Adjustment of input horsepower		
	Tightening amount of adjusting screw (C) (628) (Turn)	Compensating control starting pressure change amount (kgf/cm ²)	Input torque change amount (kgf · m)
1900	+1/4	+15.9	+2.5

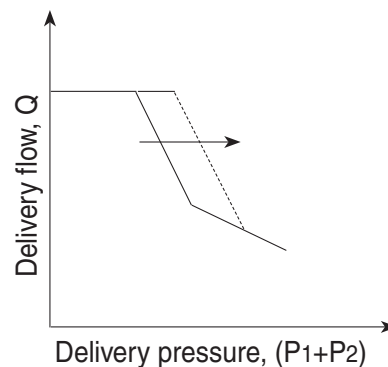

b. Adjustment of inner spring

Adjust it by loosening the hexagon nut (802) and by tightening (or loosening) the adjusting stem C (627).

Tightening the screw increases the flow and then the input horsepower as shown in the figure.

※ **Adjusting value**

Speed	Adjustment of input horsepower		
	Tightening amount of adjusting stem (C) (627)	Flow change amount	Input torque change amount
(min ⁻¹)	(Turn)	(ℓ/min)	(kgf · m)
1900	+1/4	+3.22	+3.2

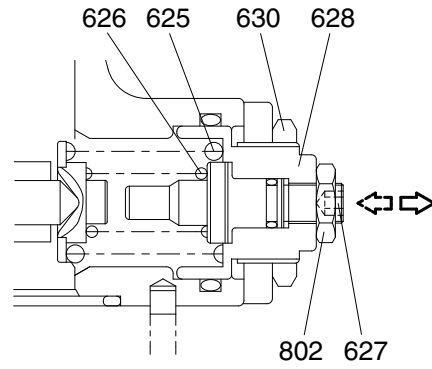

140Z92RG08

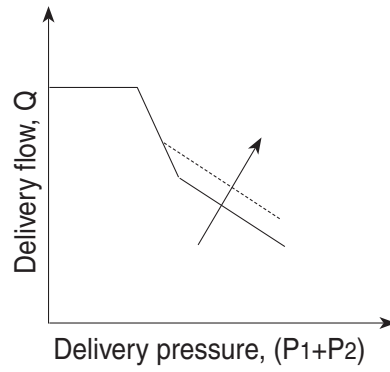

(3) Power shift control

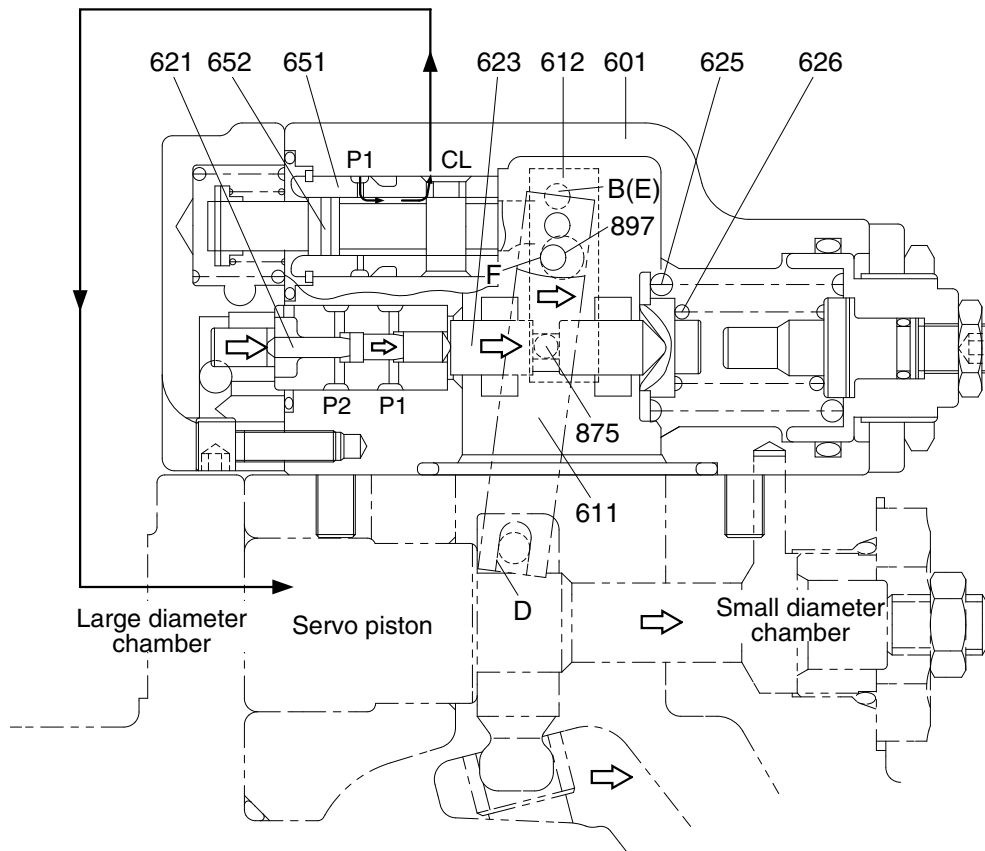

140Z92RG05

The set horsepower valve is shifted by varying the command current level of the proportional pressure reducing valve attached to the pump.

Only one proportional pressure reducing valve is provided.

However, the secondary pressure P_f (power shift pressure) is admitted to the horsepower control section of each pump regulator through the pump's internal path to shift it to the same set horsepower level.

This function permits arbitrary setting of the pump output power, thereby providing the optimum power level according to the operating condition.

The power shift pressure P_f controls the set horsepower of the pump to a desired level, as shown in the figure.

As the power shift pressure P_f rises, the compensating rod (623) moves to the right via the pin (898) and compensating piston (621).

This decreases the pump tilting angle and then the set horsepower in the same way as explained in the overload preventive function of the horsepower control. On the contrary, the set horsepower rises as the power shift pressure P_f falls.

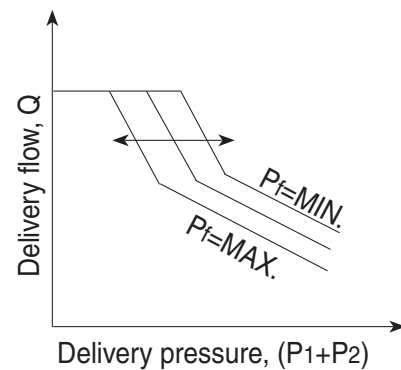

(4) Adjustment of maximum and minimum flows

① Adjustment of maximum flow

Adjust it by loosening the hexagon nut (808) and by tightening (or loosening) the set screw (954).

The maximum flow only is adjusted without changing other control characteristics.

Speed (min ⁻¹)	Adjustment of max flow	
	Tightening amount of adjusting screw (954) (Turn)	Flow change amount (ℓ/min)
1900	+1/4	-3.0

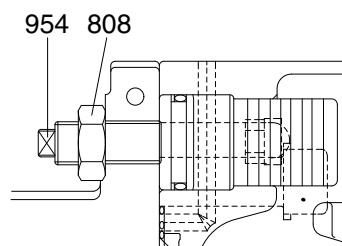

140Z92MP23

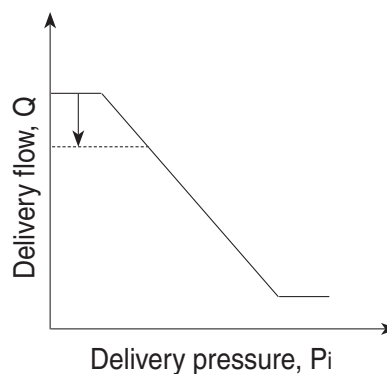

② Adjustment of minimum flow

Adjust it by loosening the hexagon nut (806) and by tightening (or loosening) the hexagonal socket head set screw (953). Similarly to the adjustment of the maximum flow, other characteristics are not changed.

However, remember that, if tightened too much, the required horsepower during the maximum delivery pressure (or during relieving) may increase.

Speed (min ⁻¹)	Adjustment of min flow	
	Tightening amount of adjusting screw (953) (Turn)	Flow change amount (ℓ/min)
1900	+1/4	+3.0

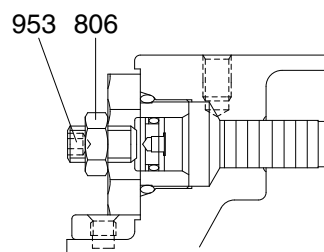

140Z92MP24

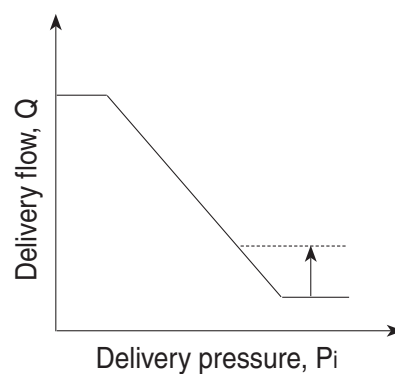

GROUP 2 MAIN CONTROL VALVE

1. STRUCTURE

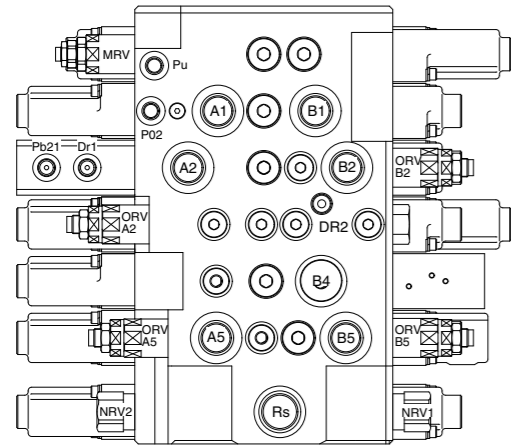

VIEW A

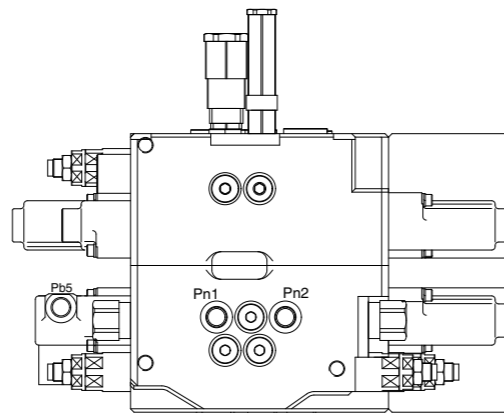
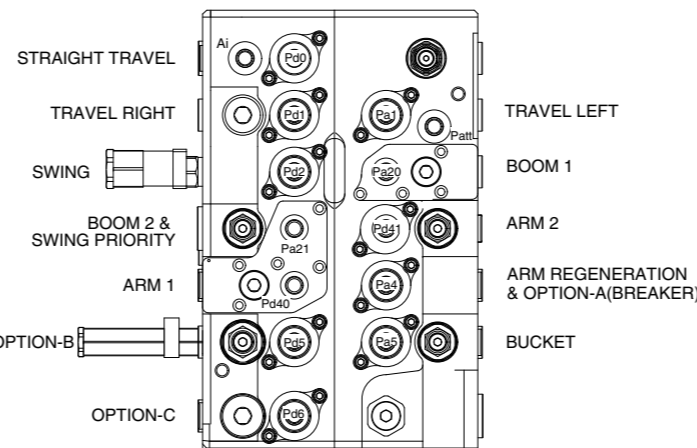
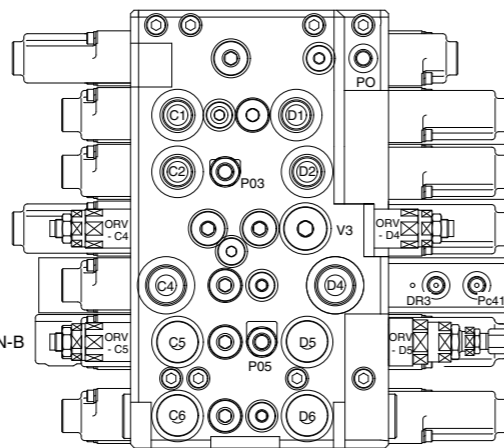
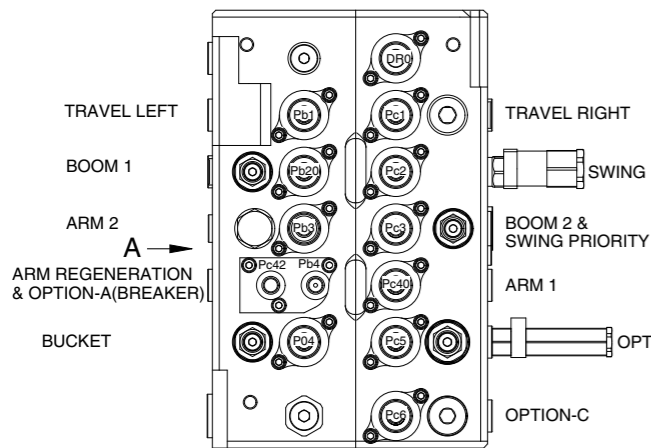
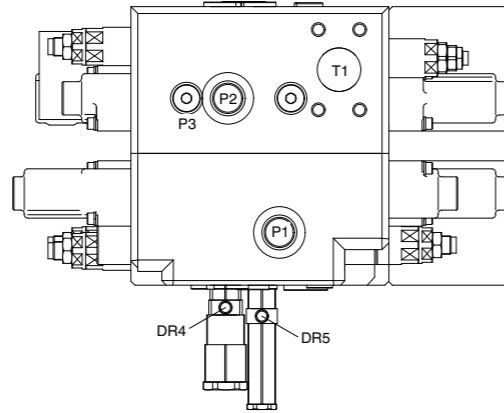

Mark	Port name	Port size	Tightening torque		
Rs	Make up for swing motor	UNF 1 3/16	18 kgf · m (130 lbf · ft)		
Pa1	Travel left pilot port (BW)	PF 1/4	3~4 kgf · m (21.7~28.9 lbf · ft)		
Pb1	Travel left pilot port (FW)				
Pc1	Travel right pilot port (FW)				
Pd1	Travel right pilot port (BW)				
Pa20	Boom up pilot port				
Pa21	Boom up confluence pilot port				
Pb20	Boom down pilot port				
Pb21	Lock valve pilot port (boom)				
Pc2	Swing pilot port (RH)				
Pd2	Swing pilot port (LH)				
Pb3	Arm in confluence pilot port				
Pc3	Swing priority pilot port				
Pa4	Option A pilot port (breaker)				
Pb4	Arm in regeneration cut port				
Pc40	Arm in pilot port				
Pc41	Lock valve pilot port (arm)				
Pc42	Arm in regen-cut signal selector port				
Pd40	Arm out pilot port				
Pd41	Arm out confluence pilot port				
Pa5	Bucket in pilot port				
Pb5	Bucket out pilot port				
Pc5	Option B pilot port				
Pd5	Option B pilot port				
Pc6	Option C pilot port (dozer blade down)				
Pd6	Option C pilot port (dozer blade up)				
P0	Pilot pressure port				
Pu	Main relief pressure up pilot port				
Ai	Auto idle signal port				
Patt	Auto idle signal-attachment				
P02	Pilot signal port				
P03	Boom priority pilot port				
P04	Boom parallel orifice pilot port				
P05	Breaker summation pilot port				
Puo	Pilot pressure port				
DR0	Drain port (travel straight)				
DR1	Drain port (boom holding valve)				
DR2	Drain port (boom 2 & swing priority)				
DR3	Drain port (arm holding valve)				
Pn1	Negative control signal port (P1 port side)			PF 3/8	6~7 kgf · m (43.4~50.6 lbf · ft)
Pn2	Negative control signal port (P2 port side)				
P3	Quick clamp port				
A1	Travel motor left side port (BW)			PF 3/4	9~10 kgf · m (65.1~72.3 lbf · ft)
B1	Travel motor left side port (FW)				
C1	Travel motor right side port (FW)				
D1	Travel motor right side port (BW)				
B2	Boom rod side port				
C2	Swing motor port (RH)				
D2	Swing motor port (LH)				
B4	Option A port (breaker)				
A5	Bucket head side port				
B5	Bucket rod side port				
C5	Option B port				
D5	Option B port				
C6	Option C pilot port (dozer down port)	PF 1	20~25 kgf · m (115~180 lbf · ft)		
D6	Option C pilot port (dozer up port)				
P1	Pump port (P1 side)	PF 1/8	1~1.2 kgf · m (7.2~8.7 lbf · ft)		
P2	Pump port (P2 side)				
A2	Boom head side port	PF 1	20~25 kgf · m (115~180 lbf · ft)		
C4	Arm head side port				
D4	Arm rod side port				
Dr4	Drain port (swing logic valve)	PF 1/8	1~1.2 kgf · m (7.2~8.7 lbf · ft)		
Dr5	Drain port (flow summation)				
T1	Return port	SAE3000, 1 1/2 (M12 × 1.75)	9~10 kgf · m (65.1~72.3 lbf · ft)		

145SA2MC01

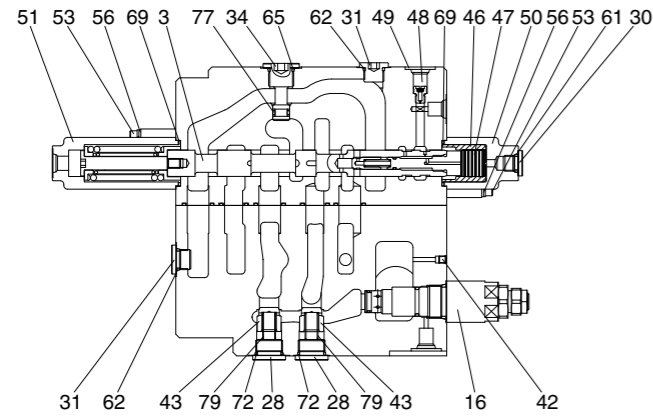

A-A (STRAIGHT TRAVEL & SUPPLY)

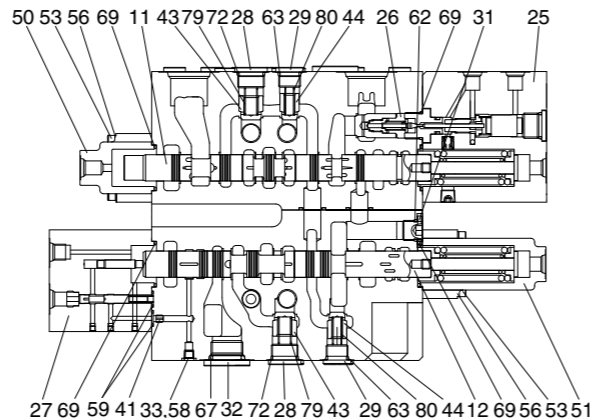

E-E (ARM 1 & ARM REGENERATION /BREAKER)

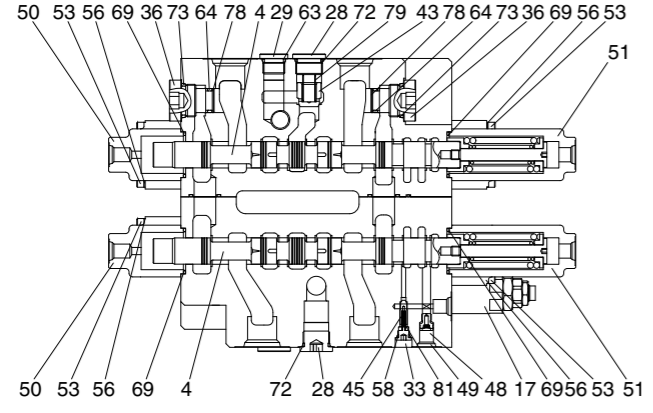

B-B (TRAVEL RIGHT & LEFT)

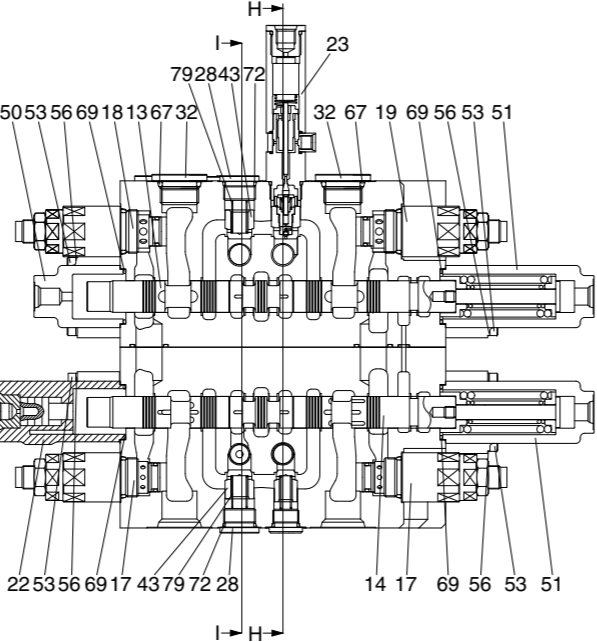

F-F (OPTION-B & BUCKET)

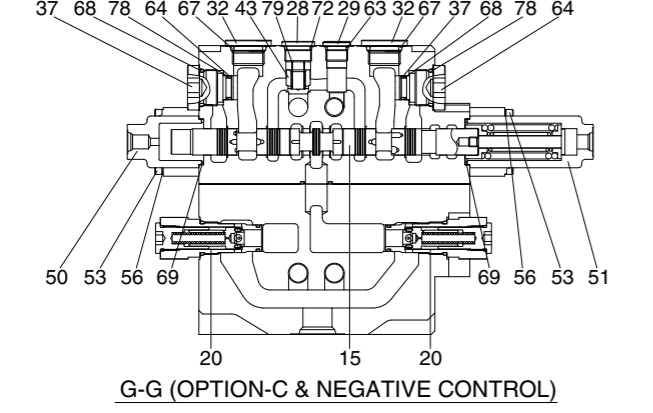

G-G (OPTION-C & NEGATIVE CONTROL)

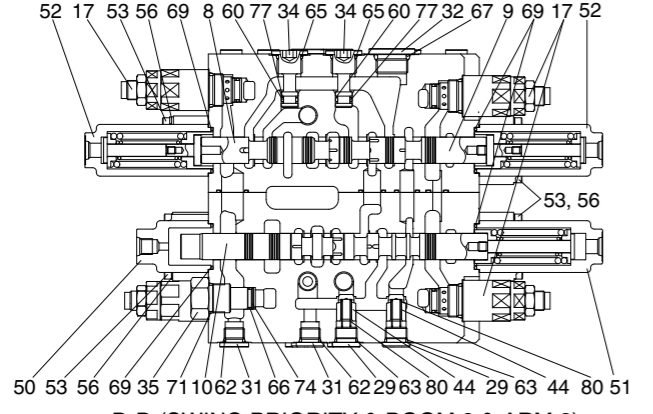

D-D (SWING PRIORITY & BOOM 2 & ARM 2)

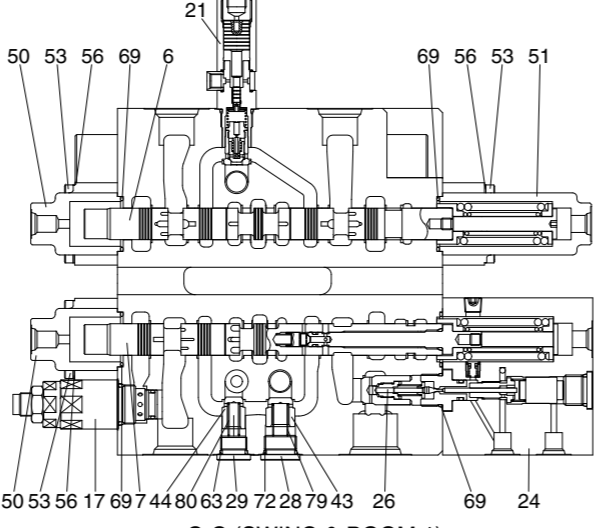

C-C (SWING & BOOM 1)

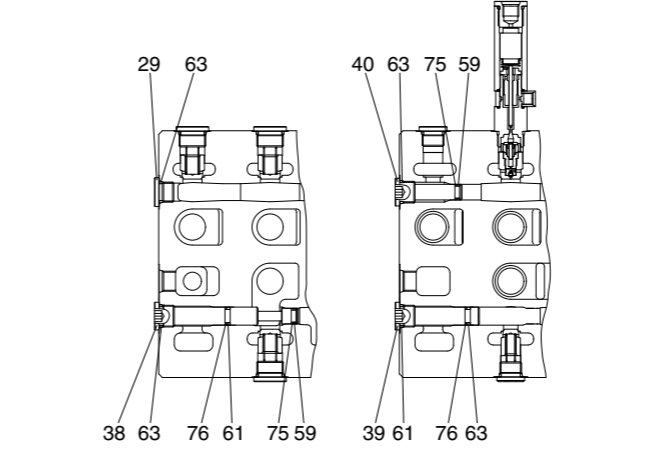
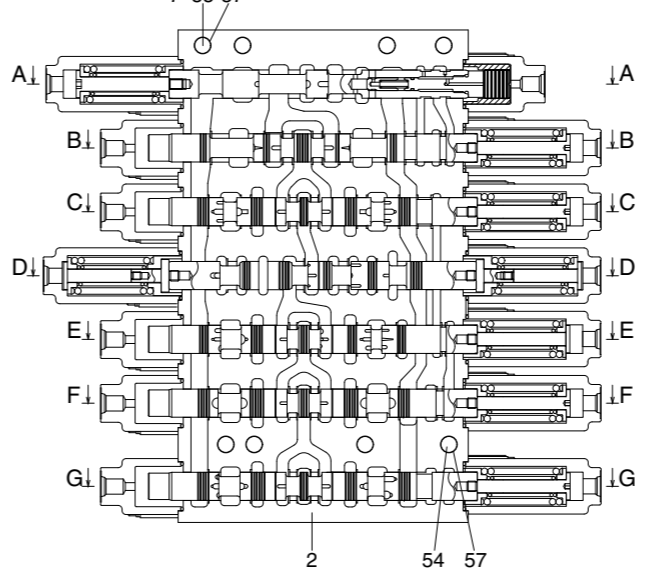
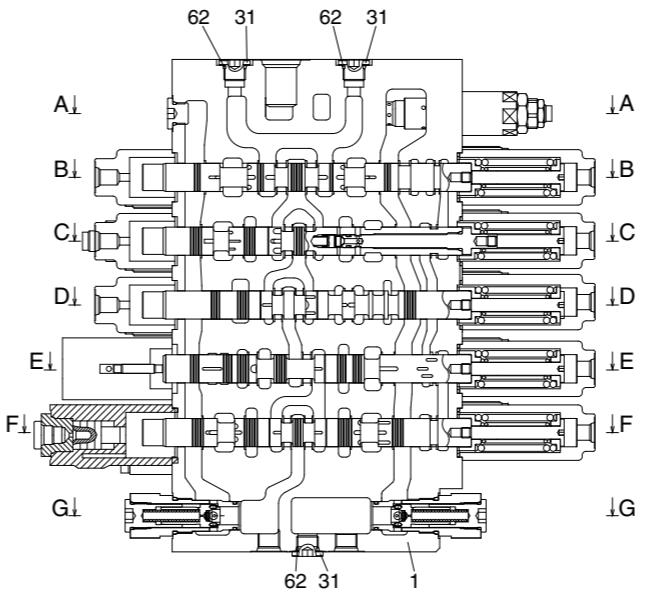

SECTION I-I

SECTION H-H

- | | |
|----------------------------|---------------------------|
| 1 Housing P1 | 43 Poppet load check |
| 2 Housing P2 | 44 Poppet load check |
| 3 Spool-straight travel | 45 Signal poppet |
| 4 Spool-travel (LH, RH) | 46 Travel straight sleeve |
| 6 Spool-swing | 47 Travel straight piston |
| 7 Spool-boom 1 | 48 Orifice signal |
| 8 Spool-swing priority | 49 Coin type filter |
| 9 Spool-boom 2 | 50 Pilot cap A |
| 10 Spool-arm 2 | 51 Pilot cap B1 |
| 11 Spool-arm 1 | 52 Pilot cap B2 |
| 12 Spool-arm regeneration | 53 Socket bolt |
| 13 Spool-option B | 54 Socket bolt |
| 14 Spool-bucket | 55 Socket bolt |
| 15 Spool-option (dozer) | 56 Washer |
| 16 Main relief valve | 57 Spring washer |
| 17 Overload relief valve | 58 O-ring |
| 18 Overload relief valve | 59 O-ring |
| 19 Overload relief valve | 60 O-ring |
| 20 Negacon relief valve | 61 O-ring |
| 21 Swing logic valve | 62 O-ring |
| 22 Bucket strock limiter | 63 O-ring |
| 23 Option on-off valve | 64 O-ring |
| 24 Holding valve kit A1 | 65 O-ring |
| 25 Holding valve kit A2 | 66 O-ring |
| 26 Holding valve kit B | 67 O-ring |
| 27 Regeneration block assy | 68 O-ring |
| 28 Plug | 69 O-ring |
| 29 Plug | 70 O-ring |
| 30 Plug | 71 O-ring |
| 31 Plug | 72 O-ring |
| 32 Plug | 73 O-ring |
| 33 Plug | 74 Backup-ring |
| 34 Plug-parallel | 75 Backup-ring |
| 35 Plug-relief cat | 76 Backup-ring |
| 36 Plug-relief cat | 77 Backup-ring |
| 37 Plug-relief cat | 78 Backup-ring |
| 38 Plug-bucket | 79 Load check spring |
| 39 Plug-bucket parallel | 80 Load check spring |
| 40 Plug-option | 81 Poppet signal spring |
| 41 Plug-orifice | 82 Regeneration block pin |
| 42 Plug | |

145LCR2MC02

2. HYDRAULIC CIRCUIT

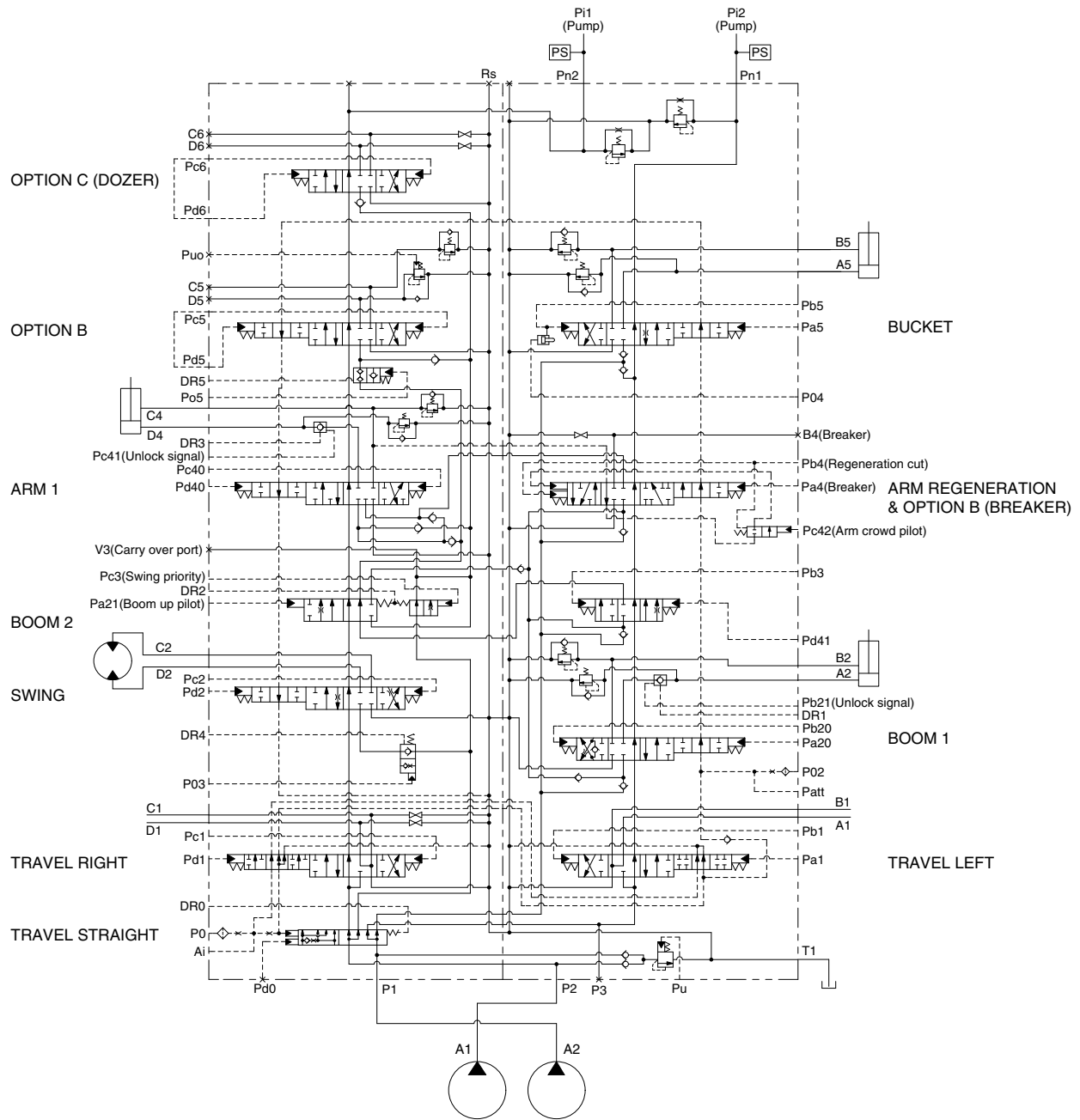

145SA2MC05

3. FUNCTION

1) CONTROL IN NEUTRAL

(1) P1 SIDE

The hydraulic fluid from pump A2 flows into the main control valve through the inlet port "P1", pass the straight travel spool into the P1 bypass passage and P1 parallel passage.

The hydraulic fluid from the pump A2 is directed to the tank through the bypass passage of spools : travel left, boom 1, arm 2, arm regeneration & option A and bucket, the negative relief valve of P1, tank passage, and the tank port "T1"

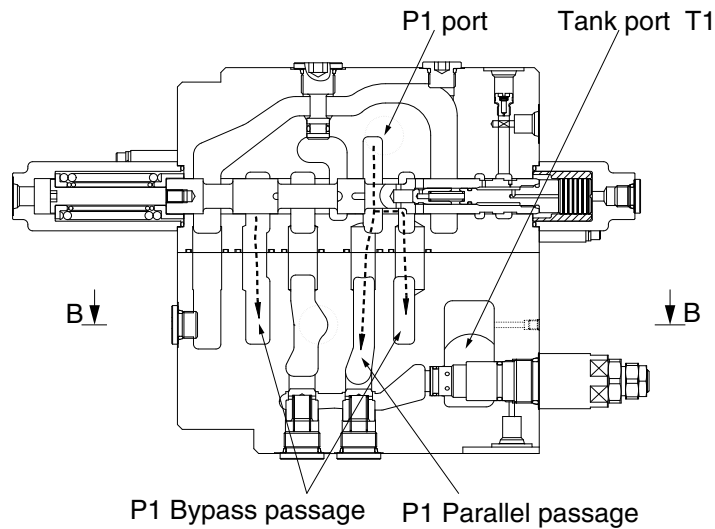

SECTION A-A

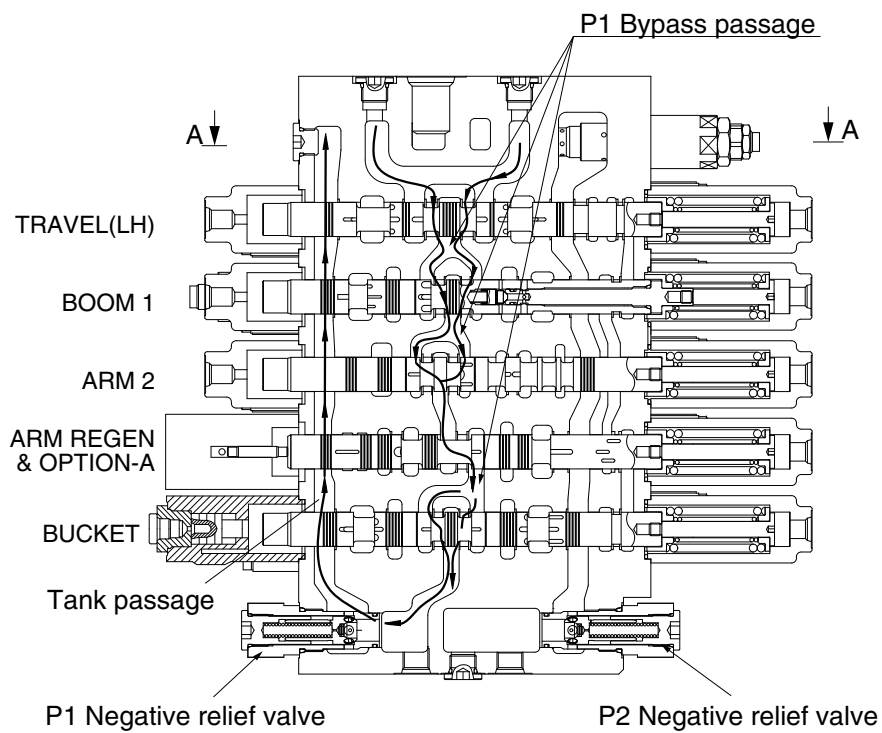

SECTION B-B

145LCR2MC11

(2) P2 SIDE

The hydraulic fluid from pump A1 flows into the main control valve through the inlet port "P2", into the P2 bypass passage and P2 parallel passage.

The hydraulic fluid from the pump A1 is directed to the tank through the bypass passage of spools : travel right, swing, boom 2 & swing priority, arm 1, option "B" and option "C" (dozer), the negative relief valve of P2, tank passage and the tank port "T1".

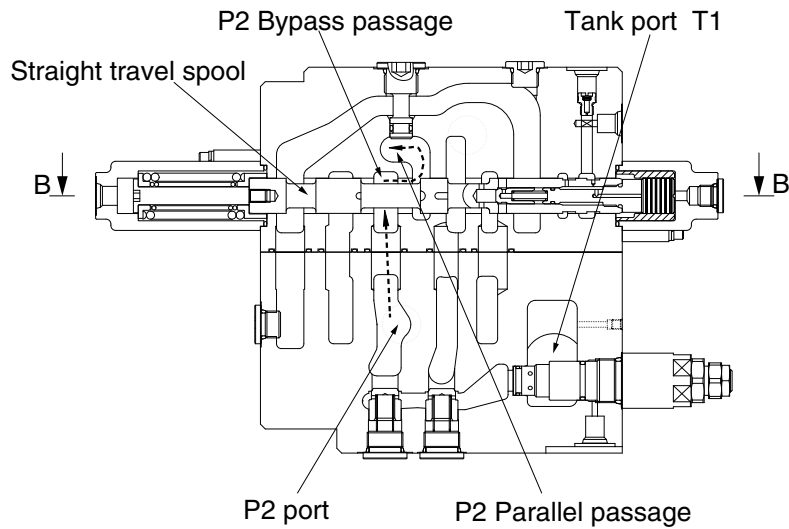

SECTION A-A

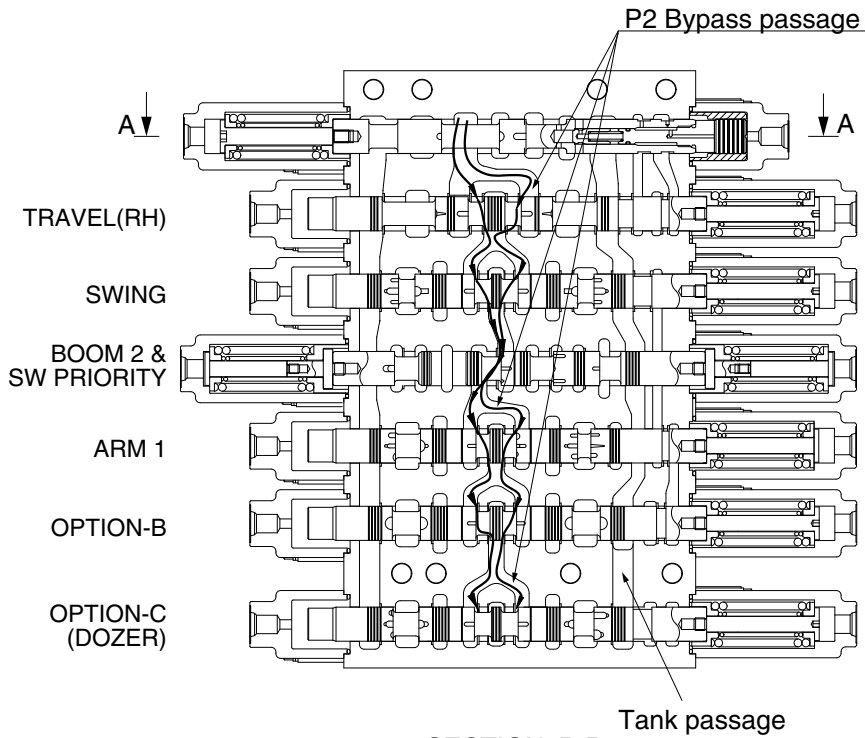

SECTION B-B

145LCR2MC12

2) TRAVEL OPERATION

(1) TRAVEL FORWARD OPERATION

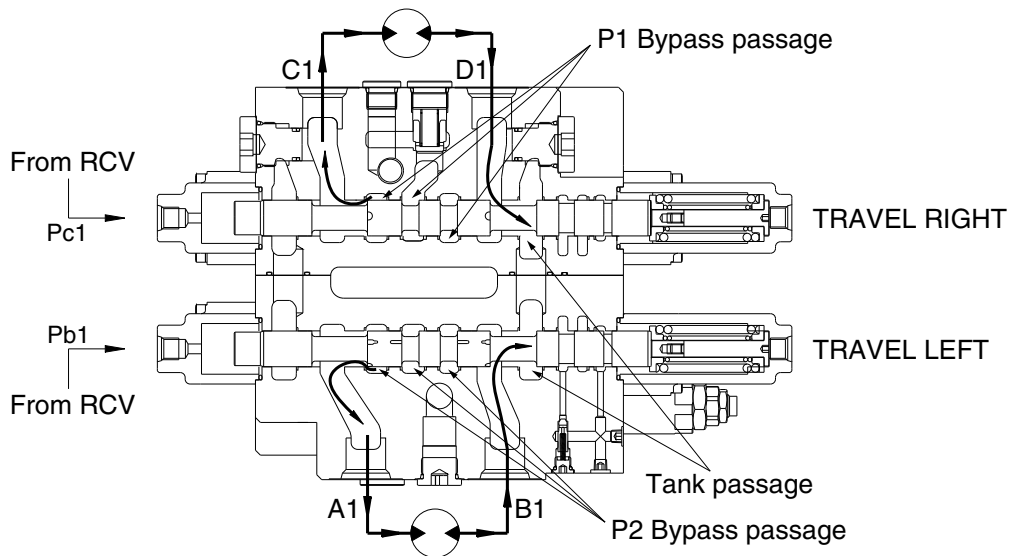

14092MC18

(2) TRAVEL BACKWARD OPERATION

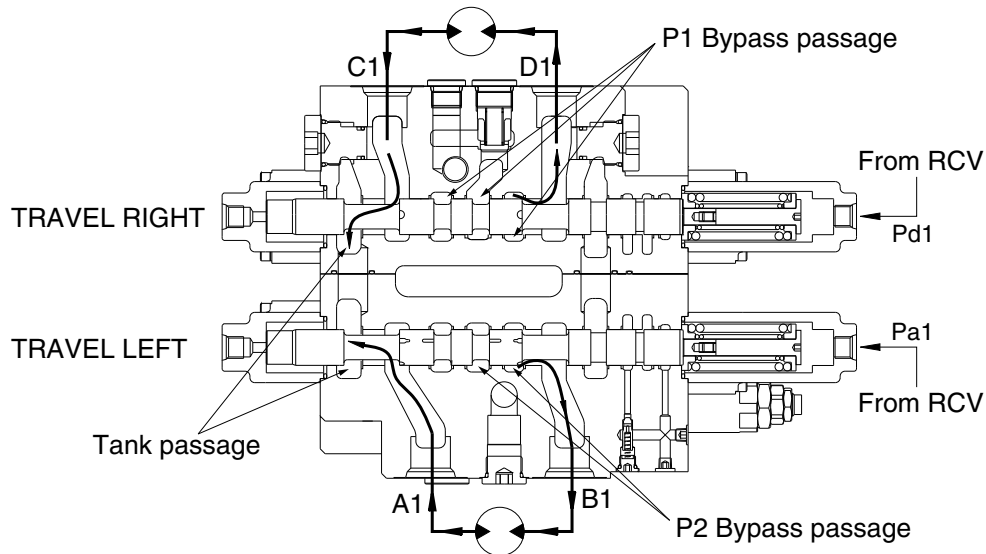

14092MC17

During the travel forward operation, the hydraulic fluid of the pump A2 is supplied to the travel left motor and the hydraulic fluid of the pump A1 is supplied to the other travel right motor.

The pilot pressure from the pilot control valve is supplied to the spring side of pilot port (pb1, pc1).

And it shifts travel right and left spools in the left direction against springs. Hydraulic fluid from the pump A1 flow into the travel right spool through the bypass passage and hydraulic fluid from the pump A2 flow into the travel left spool through the bypass passage.

Then they are directed to the each travel motor through port A1 and C1. As a result, the travel motors turn and hydraulic fluid returns to the tank passage through the travel spools.

In case of the reverse operation, the operation is similar.

(3) TRAVEL STRAIGHT FUNCTION

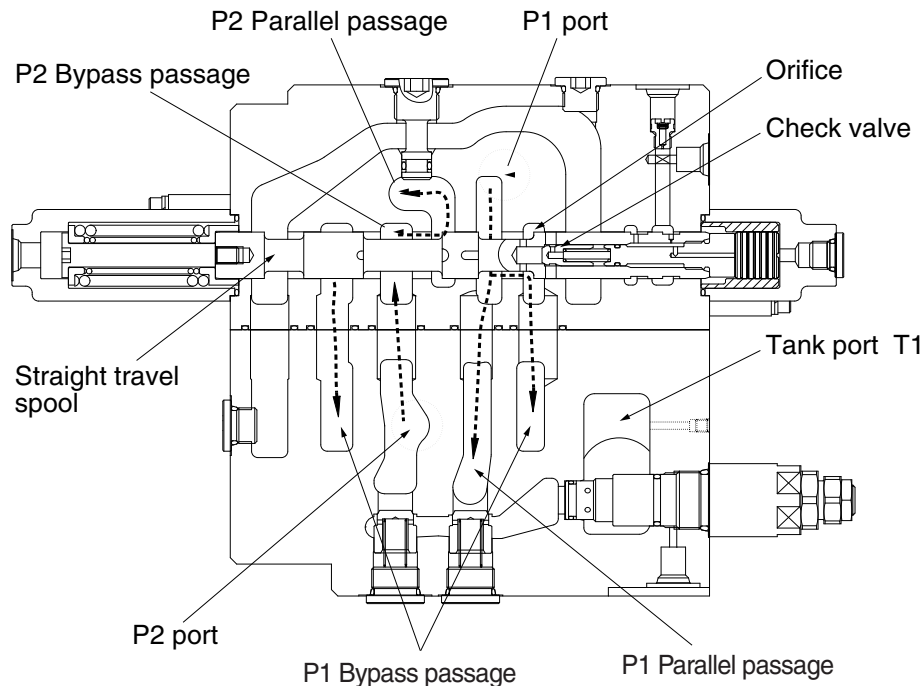

14092MC19

This function keeps straight travel in case of simultaneous operation of other actuators (boom, arm, bucket, swing) during a straight travel.

① **During travel only :**

The hydraulic fluid of the pump A1 is supplied to the travel right motor and the pump A2 is supplied to the travel left motor.

Thus, the machine keep travel straight.

② **The other actuator operation during straight travel operation :**

When the other actuator spool (s) is selected under straight travel operation, the straight travel spool is moved.

The hydraulic fluid from pump A2 is supplied actuator through P2 and P1 parallel pass and travel motors through orifice at side of straight travel spool.

The hydraulic oil fluid from pump A1 is supplied to travel motors (left/right).

Therefore, the other actuator operation with straight travel operation, hydraulic oil fluid from pump A2 is mainly supplied to actuator, and the hydraulic oil fluid form pump A1 is mainly supplied to travel motors (left/right).

Then the machine keeps straight travel.

3) BOOM OPERATION

(1) BOOM UP OPERATION

During boom up operation, the pilot secondary pressure from RCV is supplied to the port Pa20 of the spring side and shifts the boom 1 spool in the left direction. The bypass passage is shut off by the movement of the boom 1 spool and the hydraulic oil fluid from pump A2 is entered P1 parallel passage and then passes through the load check, bridge passage and boom holding valve then flows into the port A2. Following this it flows into the head side of the boom cylinder. (In this case, the boom holding valve is free flow condition)

At the same time, the pilot pressure from RCV is supplied to the port Pa21 of the spring side of boom 2 and shifts the boom 2 spool. The bypass passage is shut off by the movement of the boom 2 spool and the hydraulic oil fluid from pump A1 entered boom summation passage via the P2 parallel passage, the land of the swing priority spool, notch of the boom 2 spool, arm 2 spool and the check. The flows combine in passage and are directed to port A2 and head side of boom cylinder.

At the same time, the flow from rod side of the boom cylinder return to the boom 1 spool through the port B2. Thereafter it is directed to the hydraulic oil tank through the tank passage.

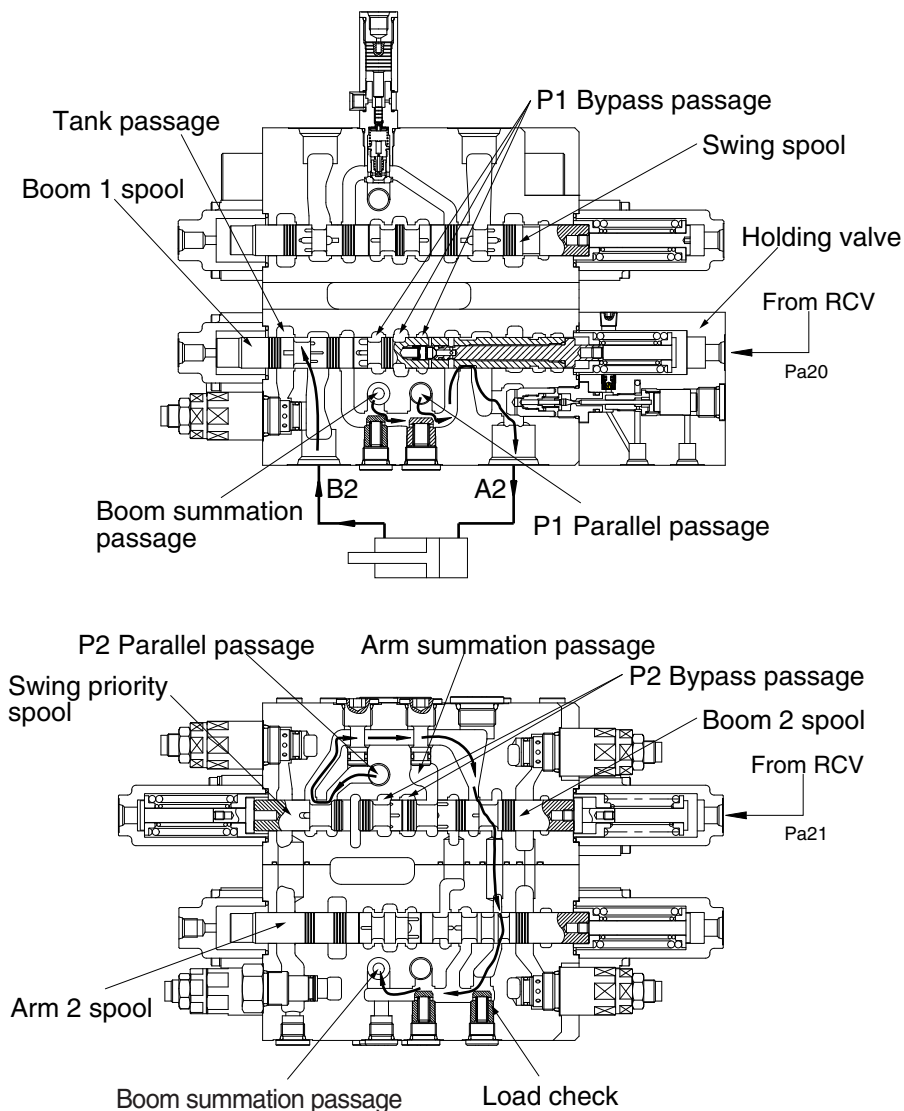

(2) BOOM DOWN OPERATION

During the boom lowering operation, the pilot pressure from RCV is supplied to the port Pb20 of the spring opposite side and shifts the boom 1 spool in the right direction.

The bypass passage is shut off by the movement of the boom 1 spool and the hydraulic fluid from the pump A2 enters the parallel passage and is directed to the port B2 through the load check. Following this, it flows into the rod side of the boom cylinder.

At the same time, the return flow from the head side of the boom cylinder returns to the port A2 and boom holding valve. And it is directed to the hydraulic oil tank through opened tank passage by movement of the boom 1 spool.

Meanwhile some of return flow is directed to P1 parallel passage through the internal passage of the boom 1 spool. (boom regeneration)

In this case, the holding valve is open condition, for details of the boom holding valve, see page following page.

During the boom lowering operation, the fluid from A1 pump is not summation.

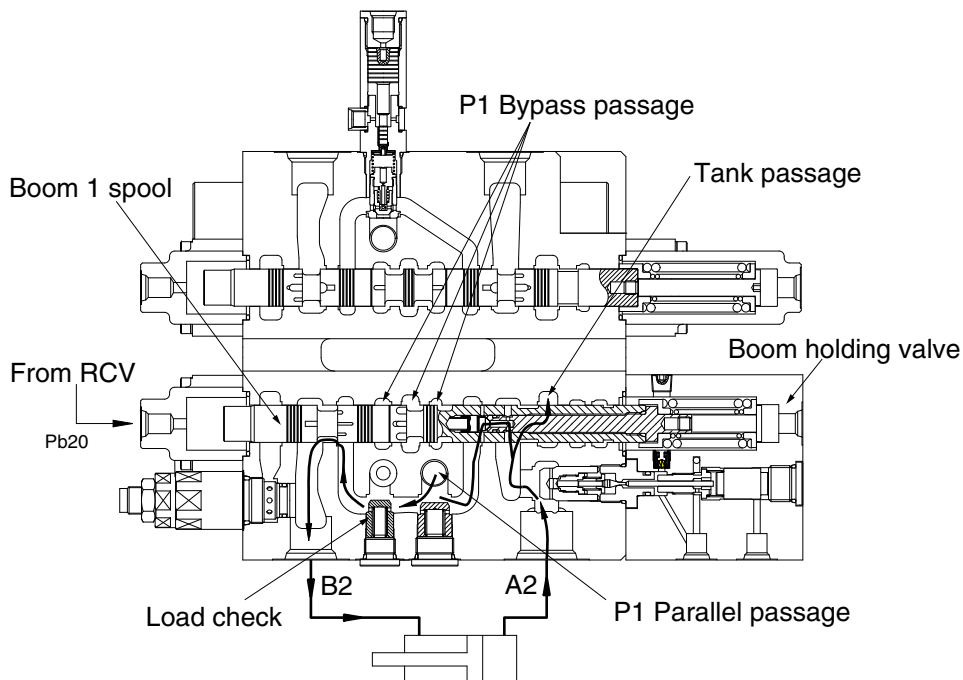

145LCR2MC26

4) HOLDING VALVE OPERATION

(1) HOLDING OPERATION

At neutral condition, the pilot piston chamber is connected to drain port through the pilot port.

And the piston "B" is supported with spring "B".

Also, the pressured fluid from actuator entered to inside of the holding valve through the periphery hole of check, crevice of the check and the plug and the periphery hole of plug.

Then, this pressured oil pushed the poppet to the poppet seat and the check to the seat of body.

So the hydraulic fluid from actuator is not escaped and the actuator is not moved.

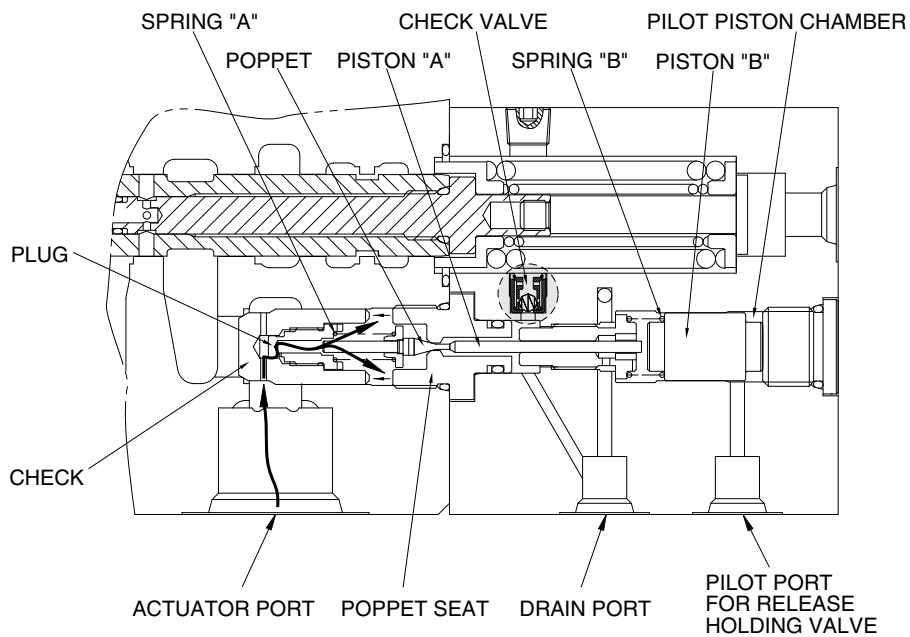

145LCR2MC15

(2) RELEASE HOLDING OPERATION

The pilot pressure is supplied to the pilot port for release holding valve and shifts the piston "B" in the left direction against the spring "B", and shifts the poppet in the left direction through piston "B" and piston "A" against spring "B" and shifts the spool in the left side.

At same time, the return fluid from actuator returns to the drain port through the periphery hole of check, crevice of the check and the plug, the periphery hole of the plug, in side of holding valve, crevice of the poppet and the poppet seat, the periphery hole of the poppet seat, crevice of socket and spool and internal passage of spool.

When the poppet is opened, pressure of inside of holding valve is decreased and the return fluid from actuator returns to the tank passage through the notch of spool.

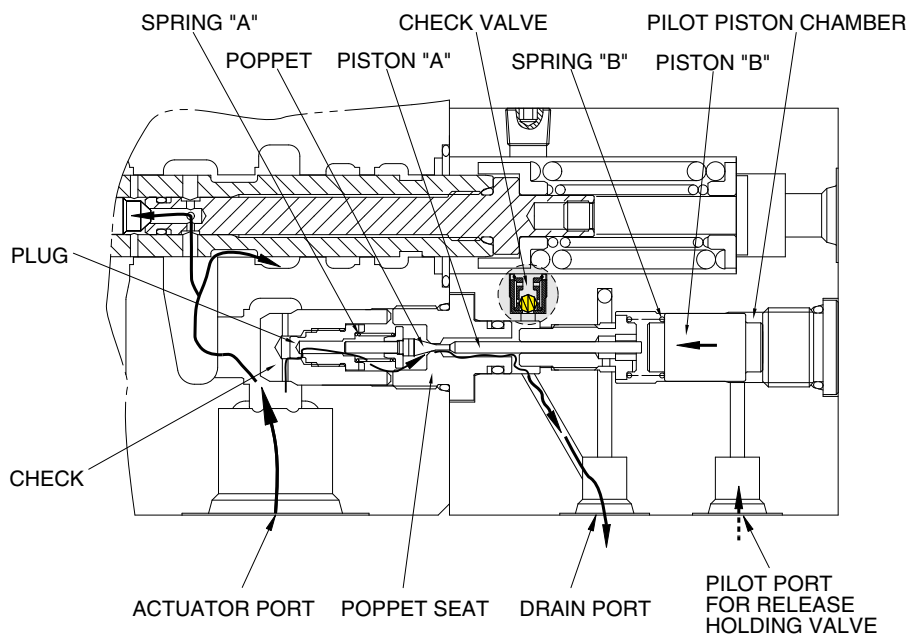

145LCR2MC16

5) BUCKET OPERATION

(1) BUCKET IN OPERATION

During the bucket in operation, the pilot secondary pressure from RCV is supplied to port Pa5 of the spring side and shifts the bucket spool in the left direction.

The bypass passage is shut off by the movement of the bucket spool and the hydraulic fluid from pump A2 entered P1 parallel passage and is directed to the port A5 through the check 1.

At the same time, the hydraulic fluid from P1 bypass passage is directed to the port A5 through the check 2.

Following this it flows into the head side of the bucket cylinder.

The return flow from the rod side of the bucket cylinder returns to the bucket spool through the port B5. Thereafter it is directed to the hydraulic oil tank through the tank passage.

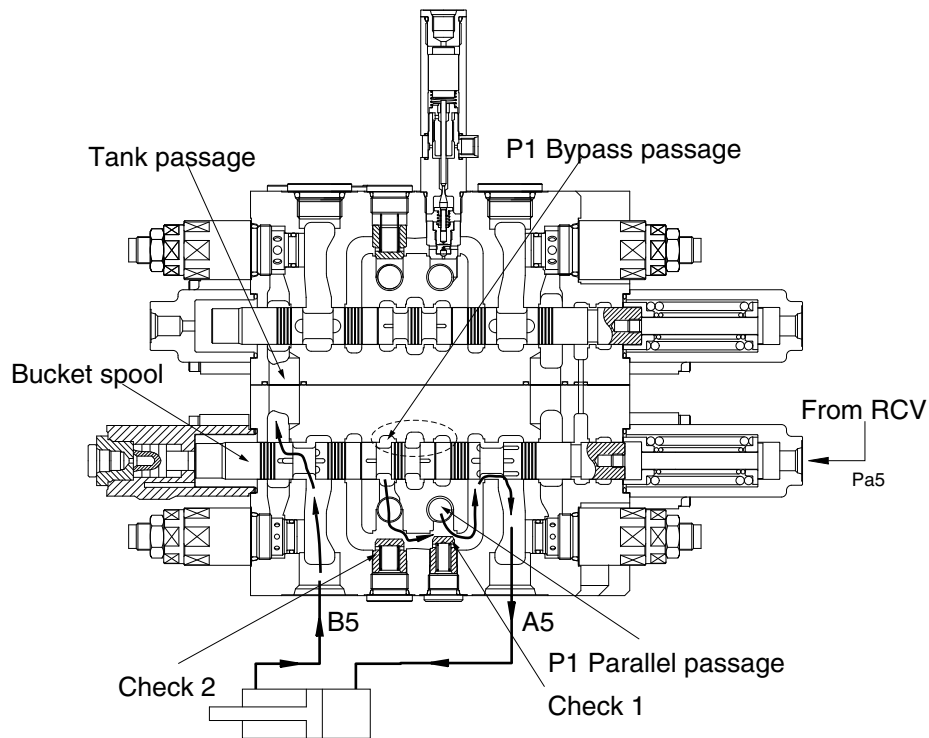

145LCR2MC34

(2) BUCKET OUT OPERATION

During the bucket out operation, the pilot secondary pressure from RCV is supplied to port Pb5 of the spring opposite side and shifts the bucket spool in the right direction.

The bypass passage is shut off by the movement of the bucket spool and the hydraulic fluid from pump A2 entered P1 parallel passage and is directed to the port B5 through the check 1.

At the same time, the hydraulic fluid from P1 bypass passage is directed to the port B5 through the check 2.

The return flow from the head side of the bucket cylinder returns to the hydraulic oil tank through the port A5 and the tank passage.

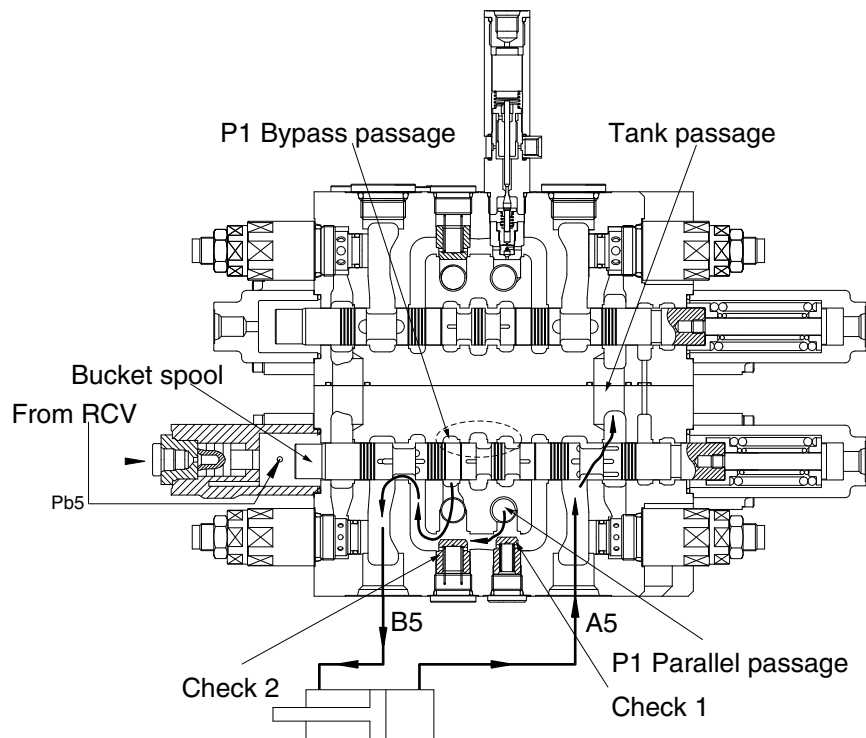

145LCR2MC35

(3) BUCKET IN OPERATION WITH BOOM UP OPERATION

When combined operation, mostly same as previous page but the fluid from P1 bypass passage is empty.

So only the fluid from P1 parallel passage is supplied to the bucket cylinder. Also, parallel passage is installed the bucket stroke limiter for supplying the fluid from pump A2 to the boom operation prior to the bucket operation. In case of the bucket out operation with boom operation, operation is similar.

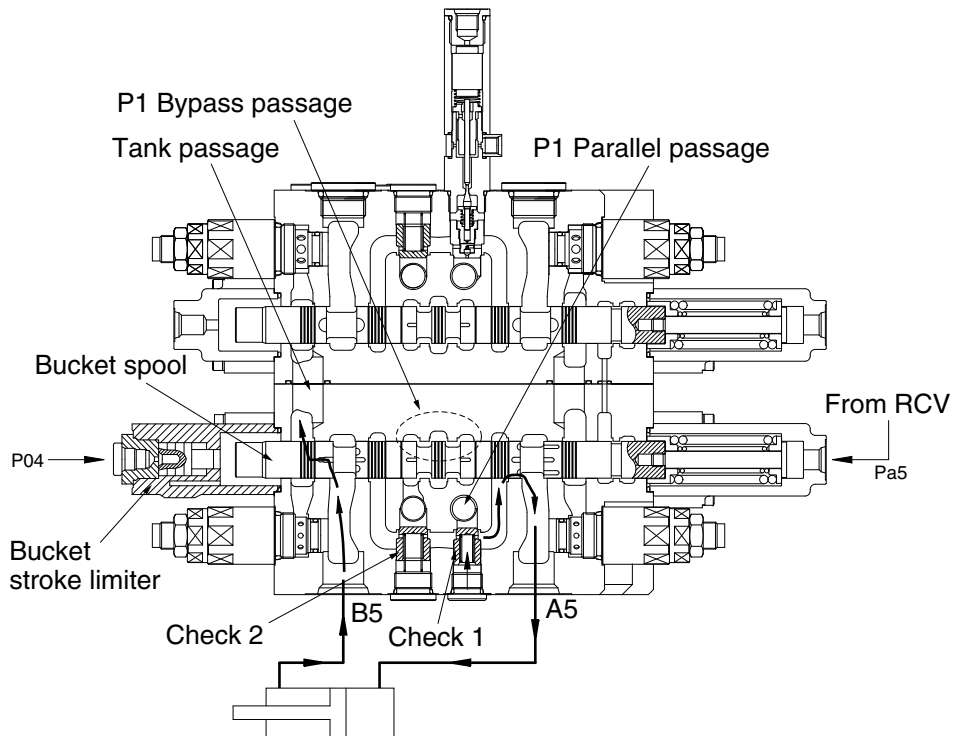

145LCR2MC29

6) SWING OPERATION

(1) SWING LEFT & RIGHT OPERATION

During the swing left operation, the pilot secondary pressure from the RCV is supplied to the port Pd2 of the spring side and shift the swing spool in left direction. The bypass passage is shut off by the movement of the swing spool and the hydraulic fluid from pump A1 flows into swing spool through the P2 parallel passage. Then it is directed to swing motor through the port D2.

As the result, swing motor turns and flow from the swing motor returns to the hydraulic oil tank through the port C2, swing spool and the tank passage.

In case of swing right operation, the operation is similar to swing left operation but the pilot secondary pressure from the RCV is supplied to the port Pc2 of the spring opposite side.

Accordingly, the hydraulic fluid from pump A1 flows into swing motor through the port C2 and returns to the hydraulic oil tank through the port D2 and the tank passage.

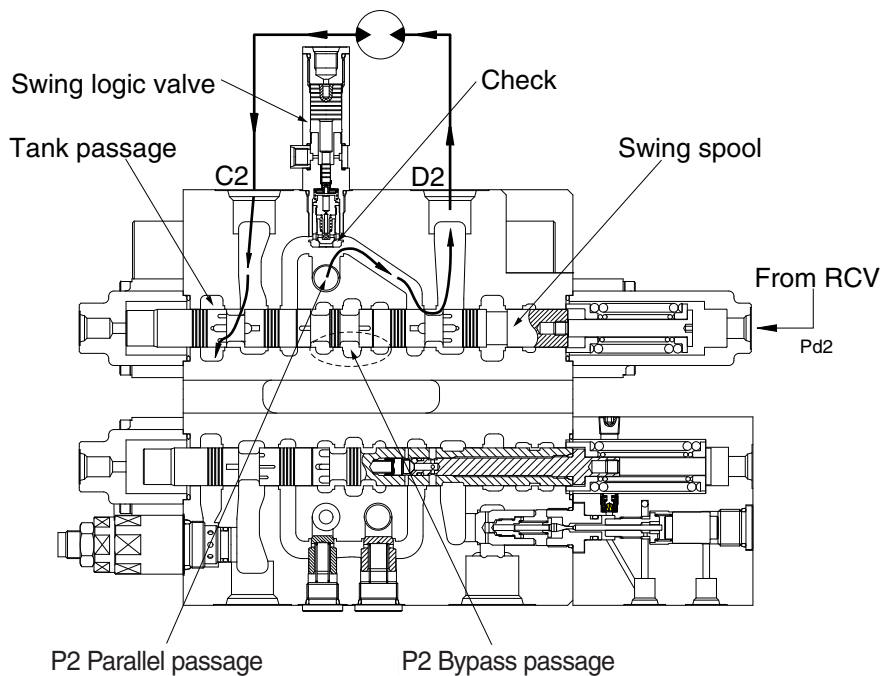

145LCR2MC32

(2) SWING LEFT OPERATION WITH ARM OR BOOM OPERATION

When combined operation, mostly same as previous page but the fluid from P2 bypass passage is empty.

So only the fluid from parallel passage is supplied to the swing motor. Also, parallel passage is installed the orifice of swing logic valve for supplying the fluid from pump A1 to the boom or the arm operation prior to the swing operation. In case of the swing right operation with arm or boom operation, operation is similar.

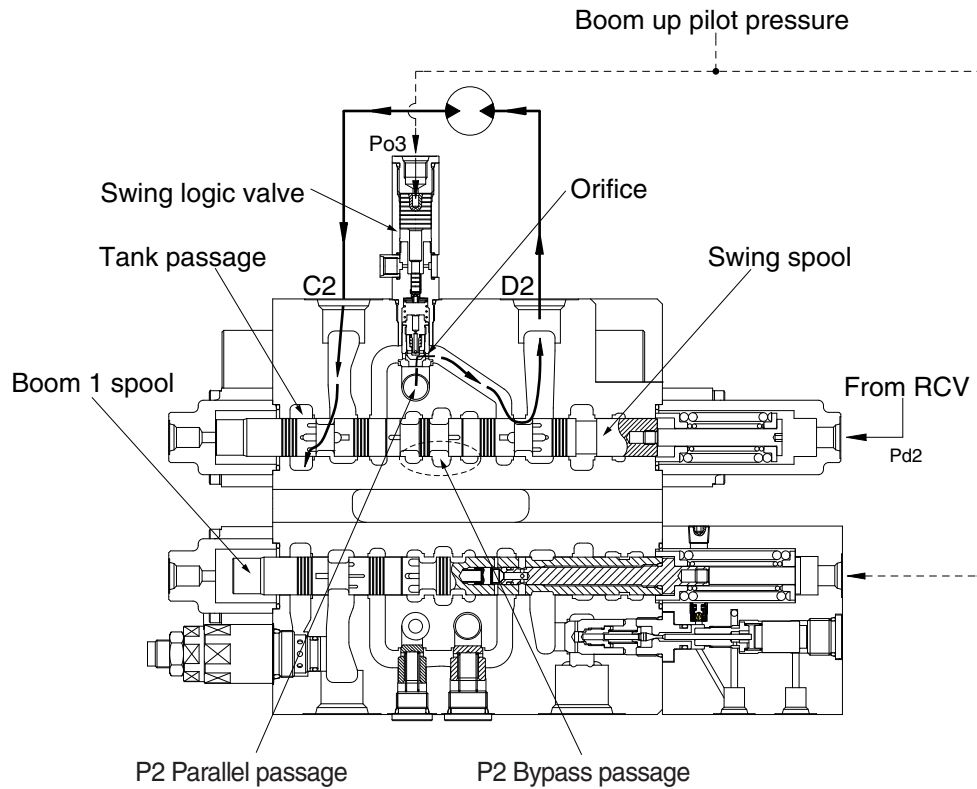

145LCR2MC20

7) ARM OPERATION

(1) ARM IN OPERATION

During arm in operation, the pilot secondary pressure from the RCV is supplied to the port Pc40 of spring opposite side and shifts arm 1 spool in the right direction.

The bypass passage is shut off by the movement of the arm 1 spool and the hydraulic oil from the pump A1 flows into the arm cylinder head side through P2 parallel passage, the load check valve, bridge passage and the port C4.

At same time, the pilot secondary pressure from the RCV is supplied to the port Pb3 of spring opposite side and shifts arm 2 spool in the right direction. The bypass passage is shut off by the movement of the arm 2 spool and the hydraulic fluid from the pump A2 flows into the arm summation passage through P1 parallel passage, the check valve, the arm 2 spool and the boom 2 spool. Then it entered the arm cylinder head side with hydraulic fluid from arm 1 spool.

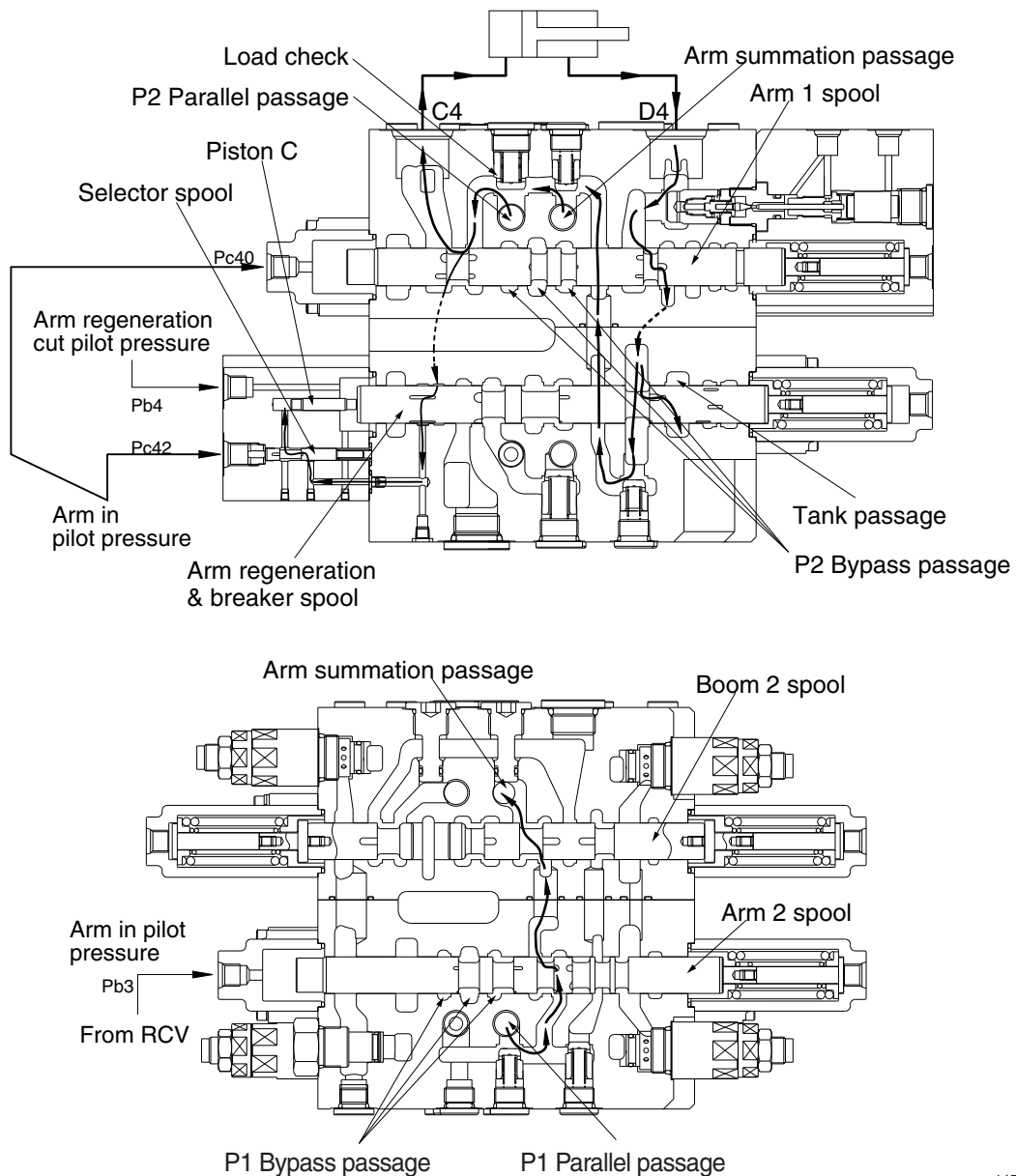

145LGR2MC21

ARM REGENERATION

The return flow from the arm cylinder rod side is pressurized by self weight of arm and so, returns to port D4. The pressurized oil returning to port D4 enters the arm regeneration & breaker spool through the arm holding valve and the arm 1 spool. It is supplied the arm cylinder head through internal passage. This is called the arm regeneration function.

The amount of regeneration fluid is changed by movement of the arm regeneration spool. A few fluids after P2 parallel passage is push piston "C" through the notch of arm regeneration spool and selector spool. At this time, the selector spool is opened by pilot pressure from RCV.

Then, the arm regeneration spool shifts to right side and flow to tank pass increases and regeneration flow decreases. Therefore, pressure of arm cylinder head increases, then, arm regeneration flow decreases.

Furthermore, the arm regeneration cut pressure is supplied to the port Pb4 of spring opposite side and arm regeneration spool is move into the right direction fully. The flow from the arm cylinder rod is returned to the hydraulic oil tank and regeneration function is not activated. (The return fluid is maximum condition)

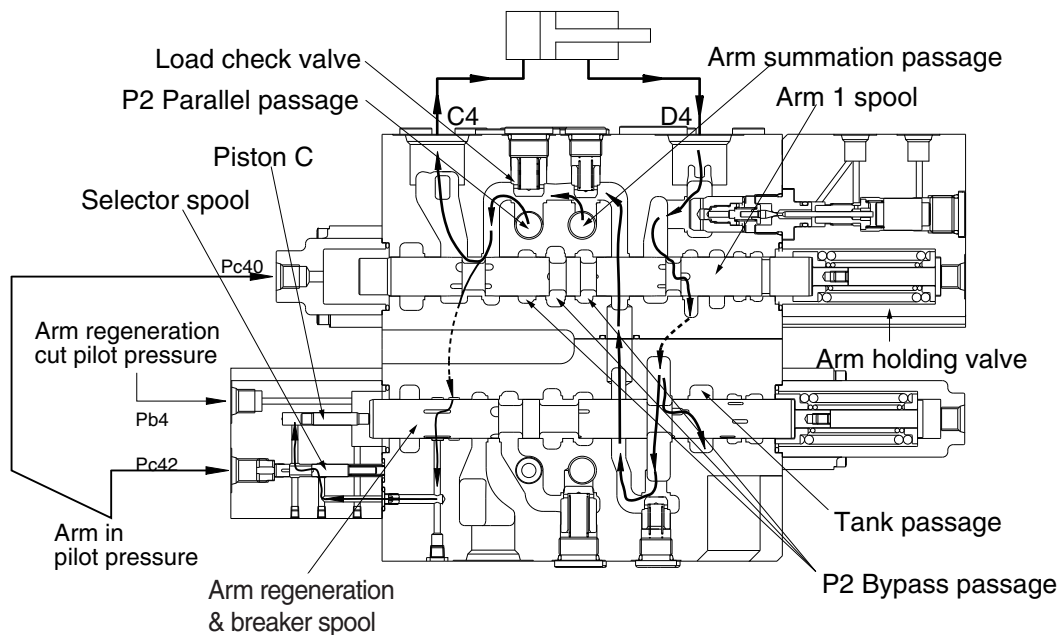

145LCR2MC22

(2) ARM OUT OPERATION

During arm out operation, the pilot secondary pressure from RCV is supplied to the port Pd40 of spring side and shifts arm 1 spool in the left direction.

The bypass passage is shut off by the movement of the arm 1 spool and the hydraulic fluid from pump A1 flows into arm 1 spool through the P2 parallel passage. Then it enters into the arm cylinder rod side through the load check, bridge passage, arm holding valve and the port D4.

Also, the pilot secondary pressure from RCV is supplied to the port Pd41 of spring side and shifts arm 2 spool in the left direction.

The bypass passage is shut off by the movement of the arm 2 spool and some of the hydraulic fluid from pump A2 bypassed through bypass notch. The rest of hydraulic fluid from pump A2 flows into the arm summation passage through P1 parallel passage, the check valve, arm 2 spool and boom 2 spool.

Then it enters into the arm cylinder rod side with the fluid from the arm 1 spool.

The return flow from the arm cylinder head side returns to the hydraulic tank through the port C4, the arm 1 spool and tank passage.

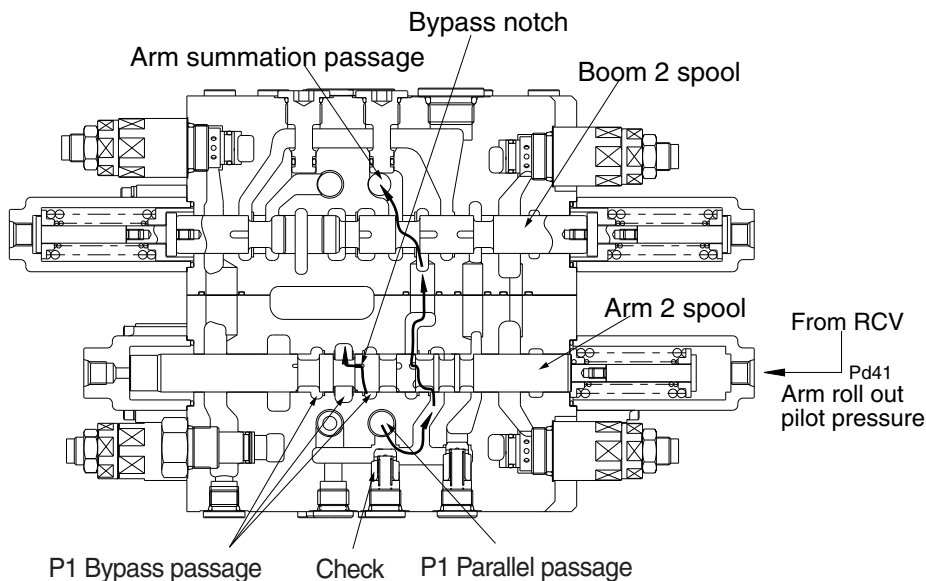
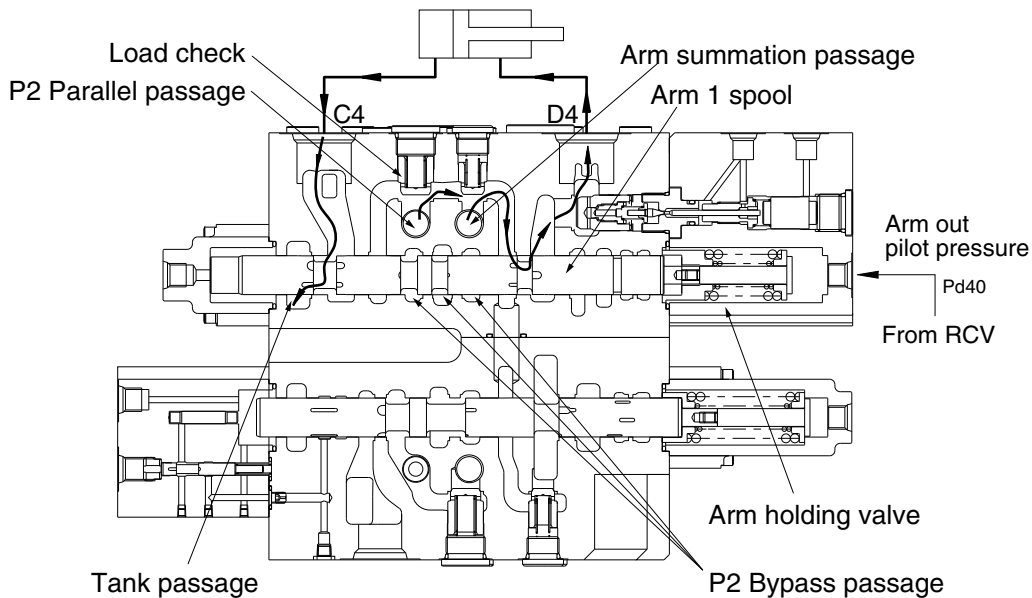

145LCR2MC23

8) SWING PRIORITY FUNCTION

During swing priority operation, the pilot secondary pressure is supplied to the port Pc3 of the spring side of the swing priority spool and shift swing priority spool in the right direction.

The hydraulic fluid from P2 parallel passage flows into the parallel passage of arm 1 side through swing priority spool and the path "A" and also flows into the boom 2 spool.

When the swing priority spool is neutral condition, the passage is same as normal condition. But due to shifting of the swing priority spool, the fluid from pump A1 flows to swing side more then the boom 2, arm 1, option B and dozer spools to make the swing operation most preferential.

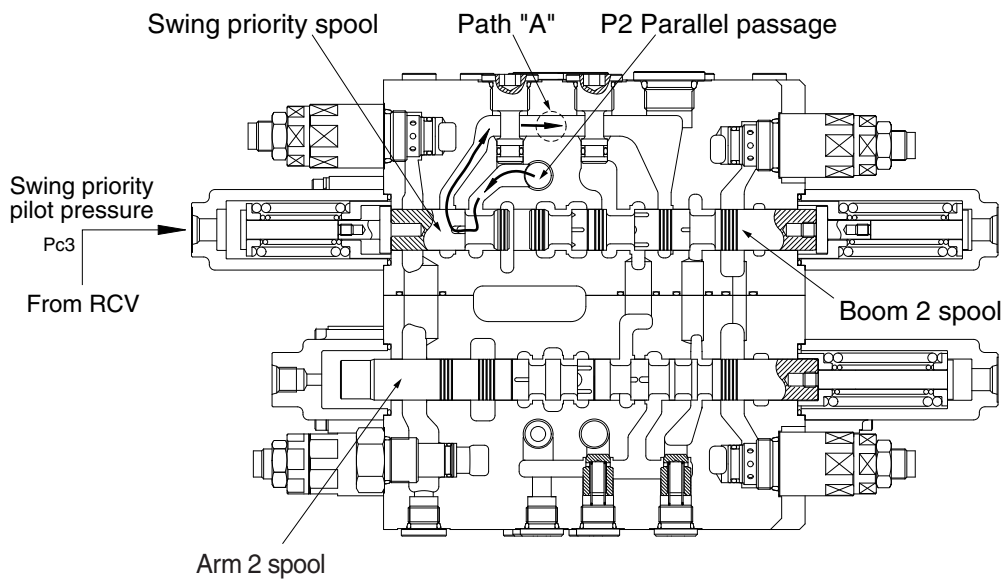

145LCR2MC27

9) DOZER OPERATION

(1) Dozer down operation

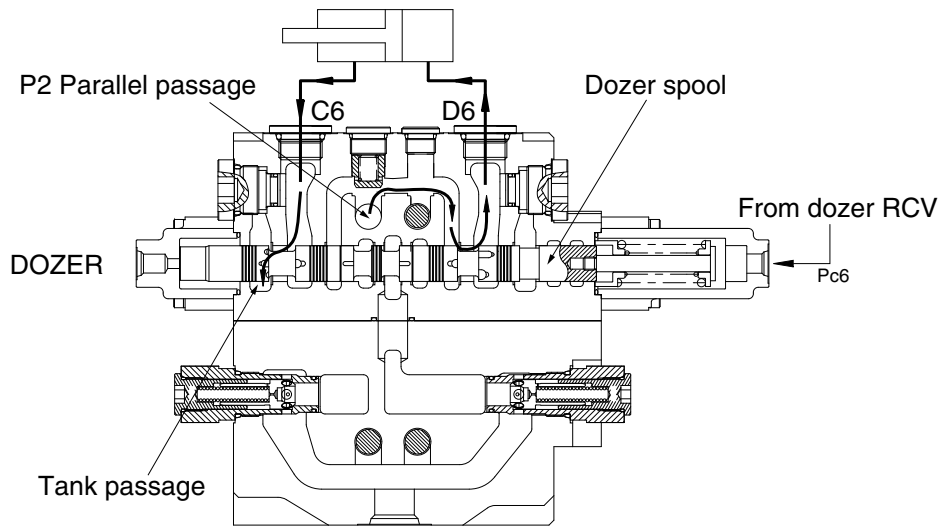

14W92MC30

(2) Dozer up operation

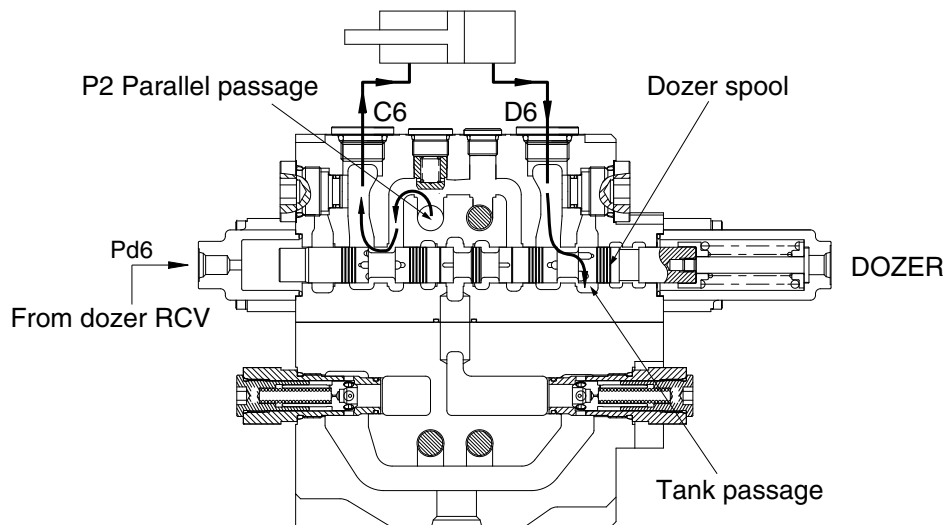

14W92MC31

During the dozer down operation, the pilot pressure from the dozer control valve is supplied into the port Pc6 of the spring side and it shifts the dozer spool in the left direction.

The hydraulic fluid from the pump A1 enters the parallel passage and is direction to the head side of the dozer cylinder through port D6.

The return flow from the rod side of the dozer cylinder returns to the dozer spool through C6 port. Thereafter it is directed to the hydraulic tank through tank passage.

In case of the dozer up operation, operation is similar.

10) NEGATIVE RELIEF VALVE OPERATION

When no function is being actuated on P1 side, the hydraulic fluid from the pump A2, flows into the tank passage through the P1 bypass passage and orifice. The restriction caused by this orifice thereby pressurizes. This pressure is transferred as the negative control signal pressure Pn1 to the pump A2 regulator.

It controls the pump regulator so as to minimize the discharge of the pump A2.

The bypass passage is shut off when the shifting of one or more spools and the flow through bypass passage became zero. The pressure of negative control signal becomes zero and the discharge of the pump A2 becomes maximum.

The negative control pressure reaches to the set level, the hydraulic fluid in the passage pushes open negative control valve and escapes into the return passage.

For the pump A1 the same negative control principle.

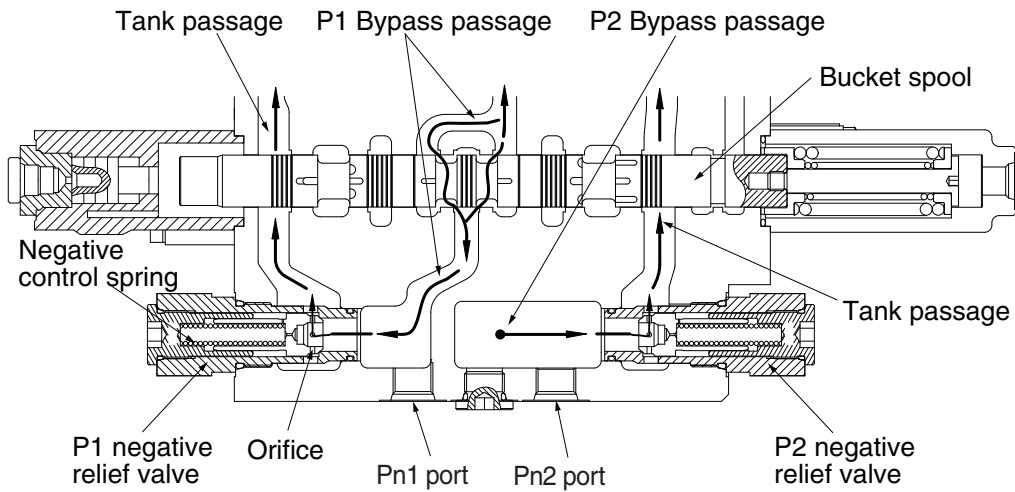

145LCR2MC28

11) OPERATION OF MAIN RELIEF VALVE

- (1) The pressurized oil passes through the orifice (A) of the plunger is filled up in chamber A of the inside space, and seats the plunger against the housing securely.

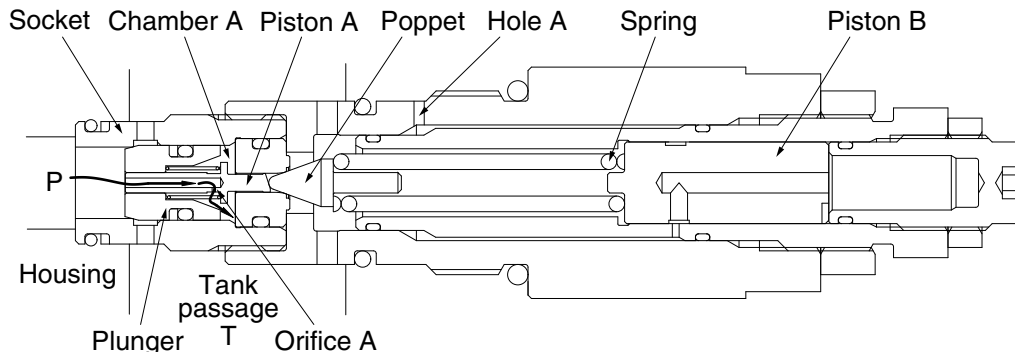

14W92MC36

- (2) When the pressure at (P) becomes equal to the set pressure of the spring the hydraulic oil passes through the piston (A) pushes open the poppet and flows to tank passage (T) through the plunger internal passage, periphery orifice A, chamber A, periphery orifice B and the hole (E).

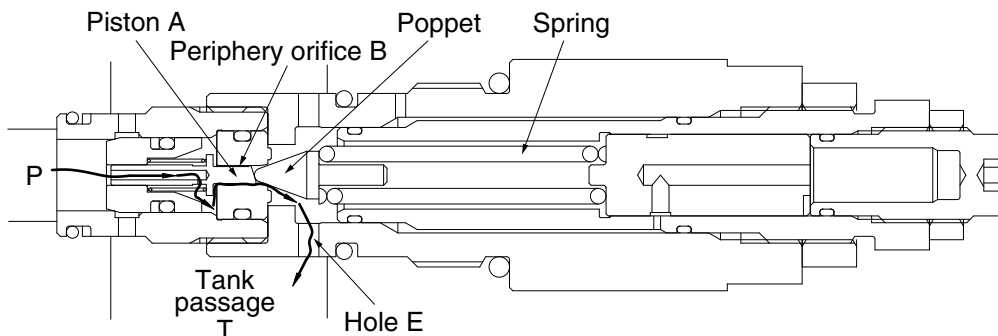

14W92MC37

- (3) Opening the poppet causes the pressure in chamber A to fall and the plunger to open. As the result the pressurized oil at port P runs into tank passage (T).

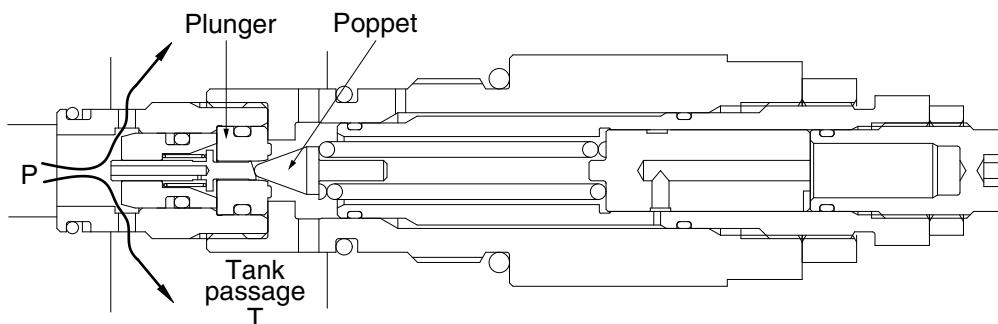

14W92MC38

- (4) The pressure at port P becomes lower than set pressure of the spring, the poppet is seated by spring force. Then the pressure at port P becomes equal to set pressure of the spring and the plunger is seated to the socket.

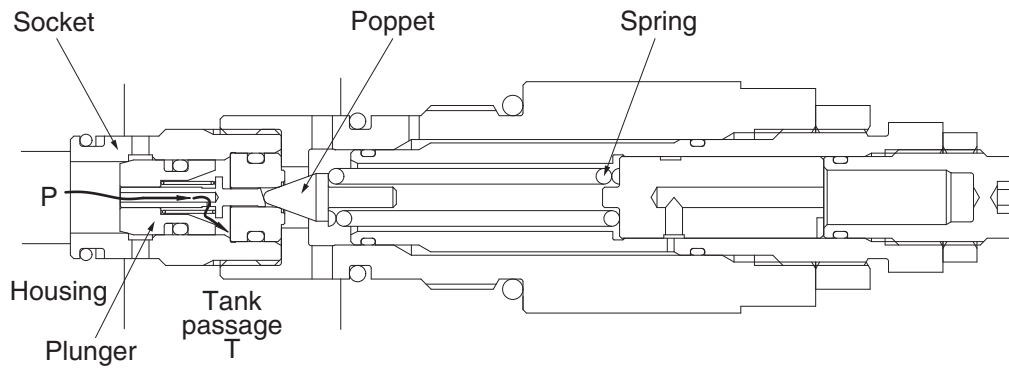

14W92MC39

- (5) When the power boost switch is ON, the pilot pressure enters through hole A. It pushes the piston (B) in the left direction to increase the force of the spring and change the relief set pressure to the high pressure.

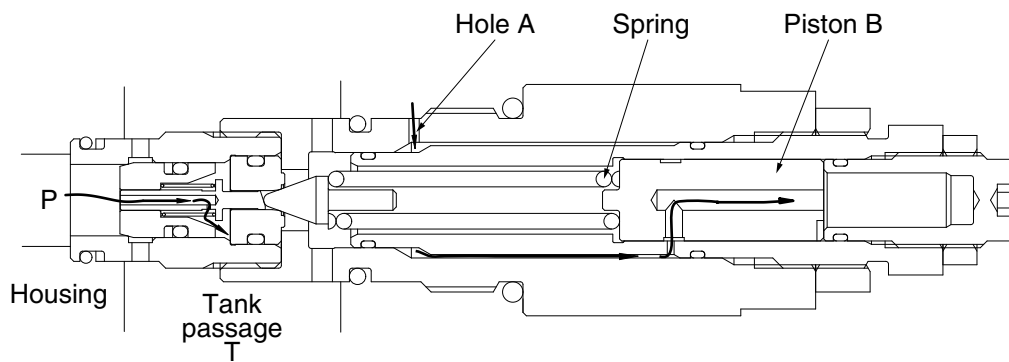

14W92MC40

12) OPERATION OF OVERLOAD RELIEF VALVE

FUNCTION AS RELIEF VALVE

- (1) The pressurized oil passes through the piston A and orifice A is filled up in chamber A of the inside space and seat the plunger against the socket and the socket against the housing securely.

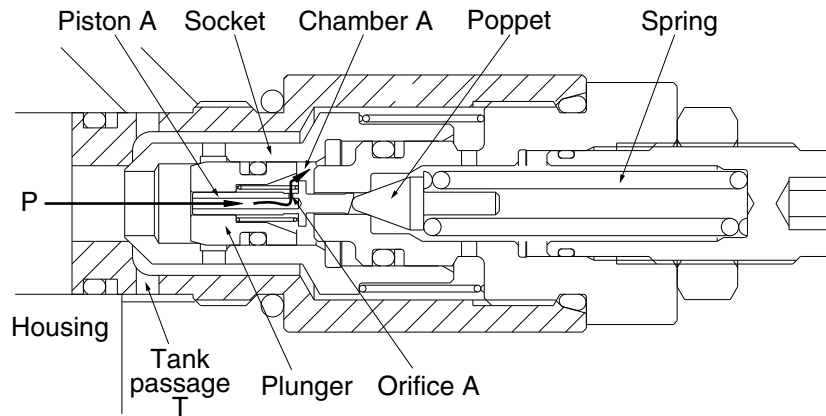

14W92MC41

- (2) When the pressure at port P becomes equal to the set pressure of the spring, the pressurized oil pushes open the poppet and flows to tank passage (T) through the plunger internal passage, orifice A, chamber A, periphery orifice B and hole E.

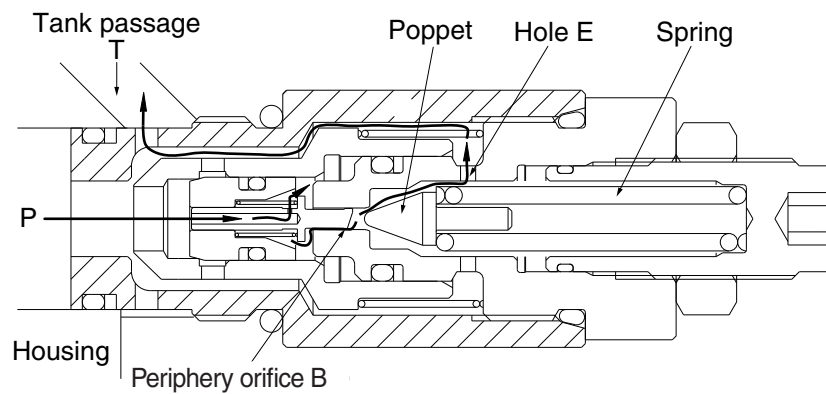

14W92MC42

- (3) Opening of the poppet causes the pressure in chamber A to fall and the plunger to open. As the result the pressurized oil at port P runs into tank passage (T).

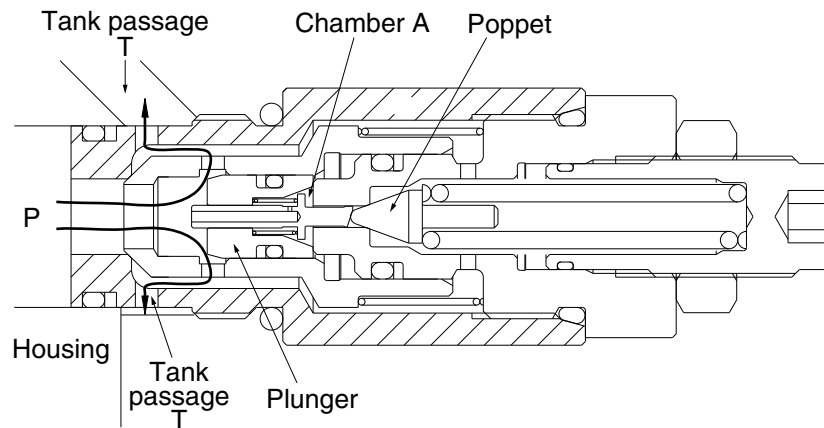

14W92MC43

- (4) The pressure at port P becomes lower than set pressure of the spring, the poppet is seated by spring force. Then the pressure at port P becomes equal to set pressure of the spring and the plunger is seated to the socket.

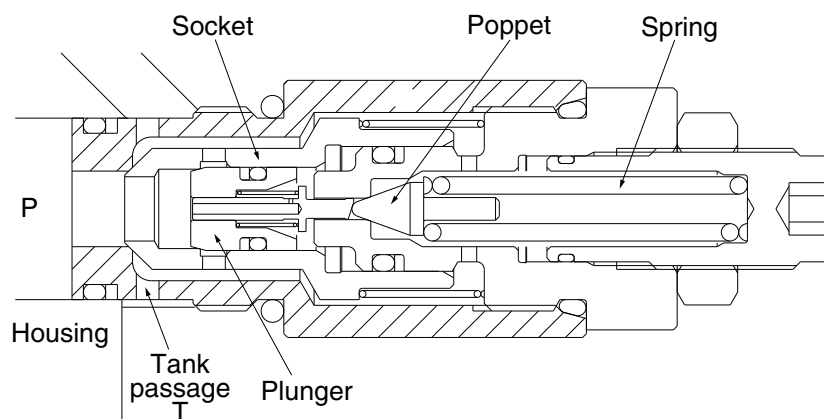

14W92MC44

MAKE-UP FUNCTION

- (5) When negative pressure exists at port P, the oil is supplied through tank passage (T). When the pressure at tank passage (T) becomes higher than that of at port P, the socket moves in the right direction. Then, sufficient oil passes around the socket from tank passage (T) to port P and fills up the space.

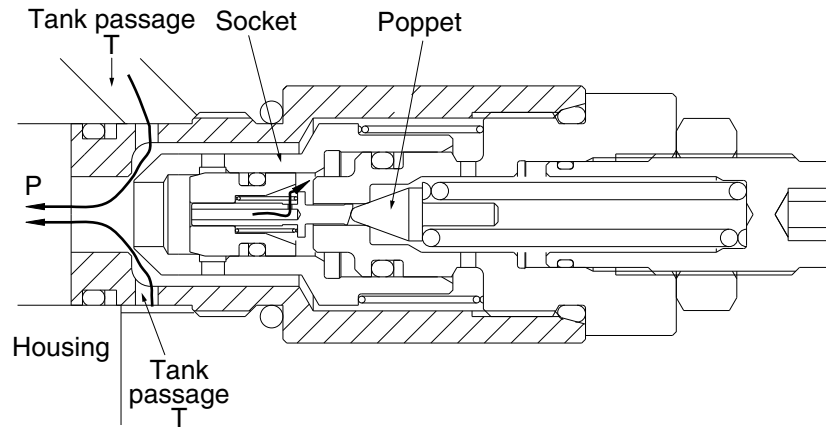

14W92MC45

GROUP 3 SWING DEVICE

1. STRUCTURE

Swing device consists swing motor, and swing reduction gear.

Swing motor include mechanical parking valve, relief valve, make up valve and time delay valve.

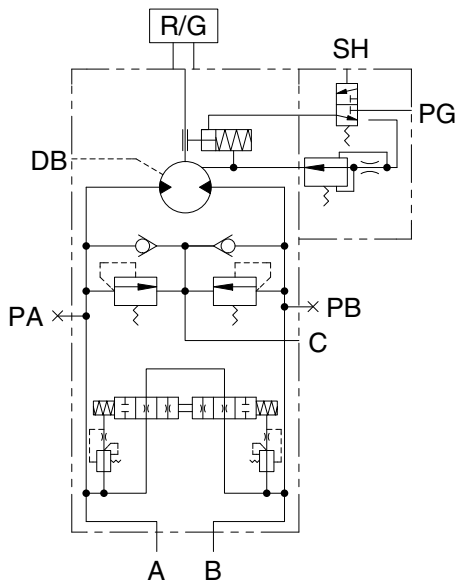
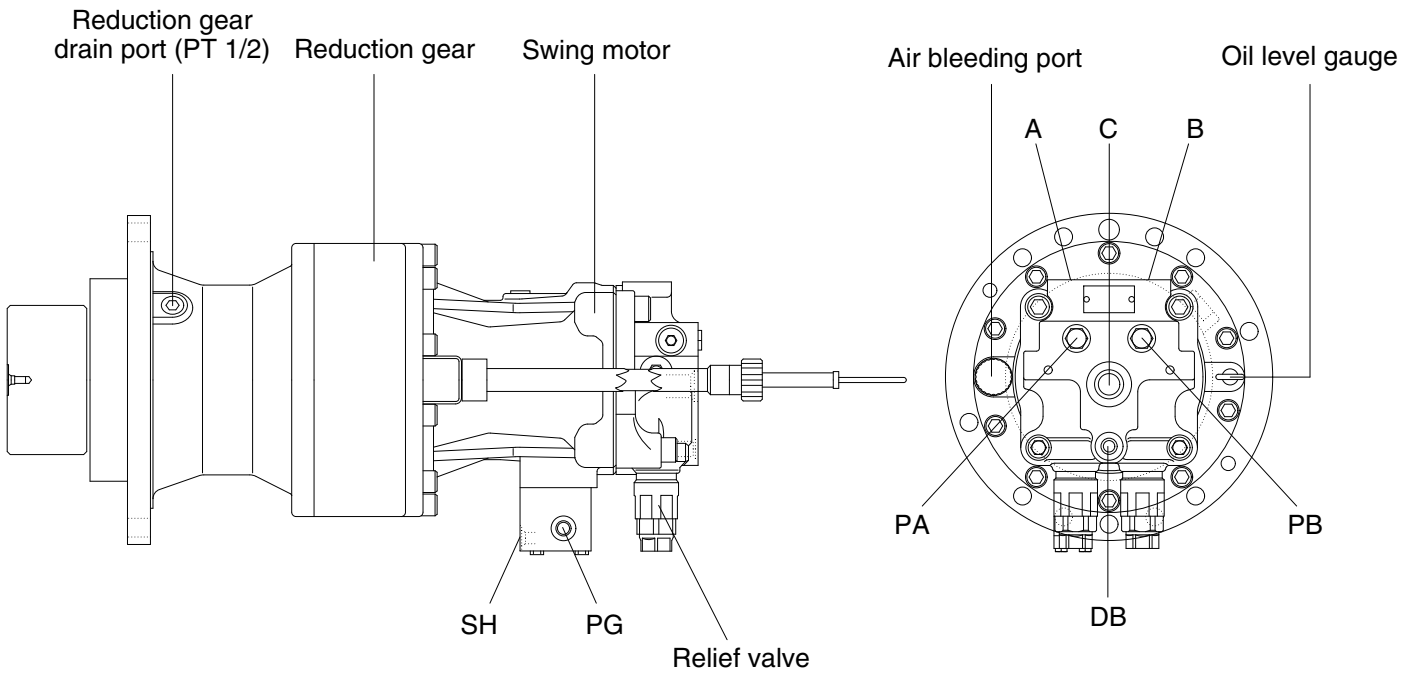

Hydraulic circuit

Port	Port name	Port size
A	Main port	Ø 13
B	Main port	Ø 13
DB	Drain port	PF 3/8
C	Make up port	PF 3/4
PG	Brake release stand by port	PF 1/4
SH	Brake release pilot port	PF 1/4
PA, PB	Gauge port	PF 1/4
Au	Air vent port	PF 1/2

145WF2SM80E

1) SWING MOTOR

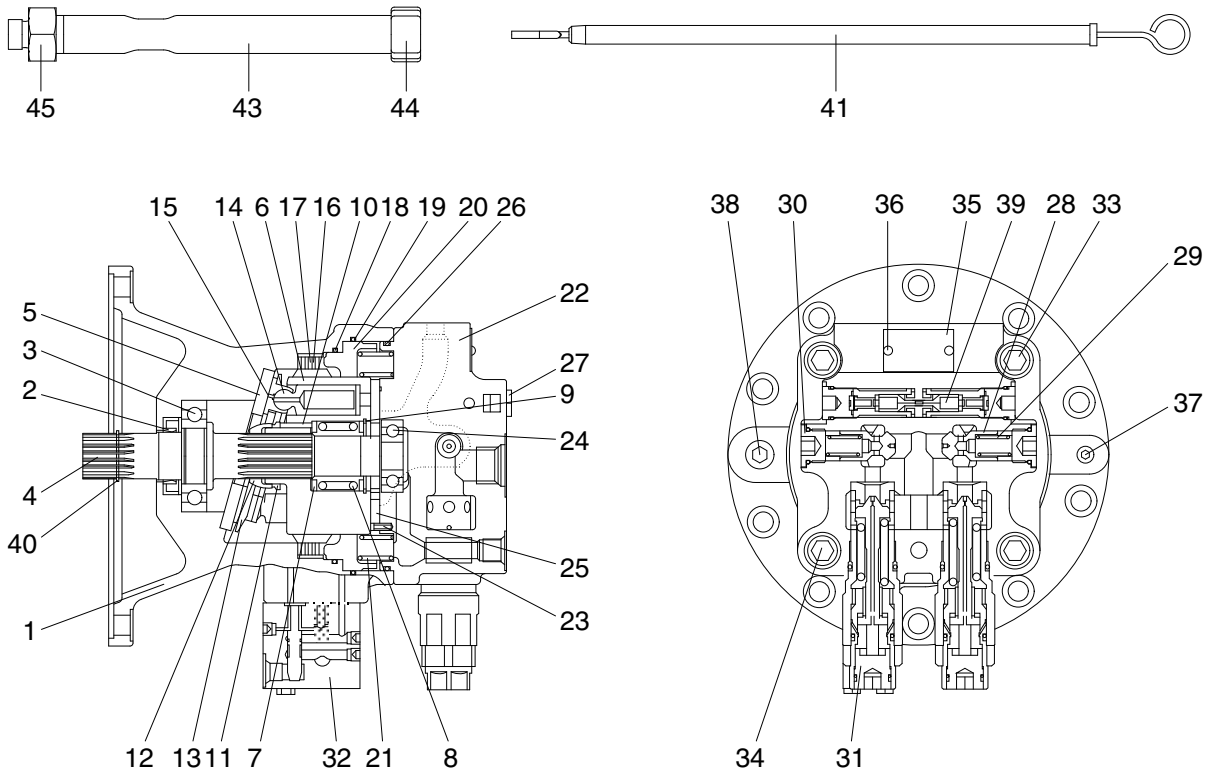

145WF2SM81

- | | | | | | |
|----|----------------|----|----------------|----|-------------------------|
| 1 | Casing | 16 | Separate plate | 31 | Relief valve assy |
| 2 | Oil seal | 17 | Friction plate | 32 | Brake valve assy |
| 3 | Ball bearing | 18 | O-ring | 33 | Socket bolt |
| 4 | Drive shaft | 19 | O-ring | 34 | Socket bolt |
| 5 | Shoe plate | 20 | Brake piston | 35 | Name plate |
| 6 | Cylinder block | 21 | Spring | 36 | Screw |
| 7 | Washer | 22 | Valve casing | 37 | Plug |
| 8 | Spring | 23 | Spring pin | 38 | Plug |
| 9 | Snap ring | 24 | Ball bearing | 39 | Reactionless valve assy |
| 10 | Roller | 25 | Valve plate | 40 | Snap ring |
| 11 | Collar washer | 26 | O-ring | 41 | Level gauge |
| 12 | Thrust ball | 27 | Plug | 42 | pipe |
| 13 | Retainer plate | 28 | Plunger | 43 | Bar |
| 14 | Piston | 29 | Spring | 44 | Cap |
| 15 | Shoe | 30 | Plug | 45 | Reducer |

2) REDUCTION GEAR

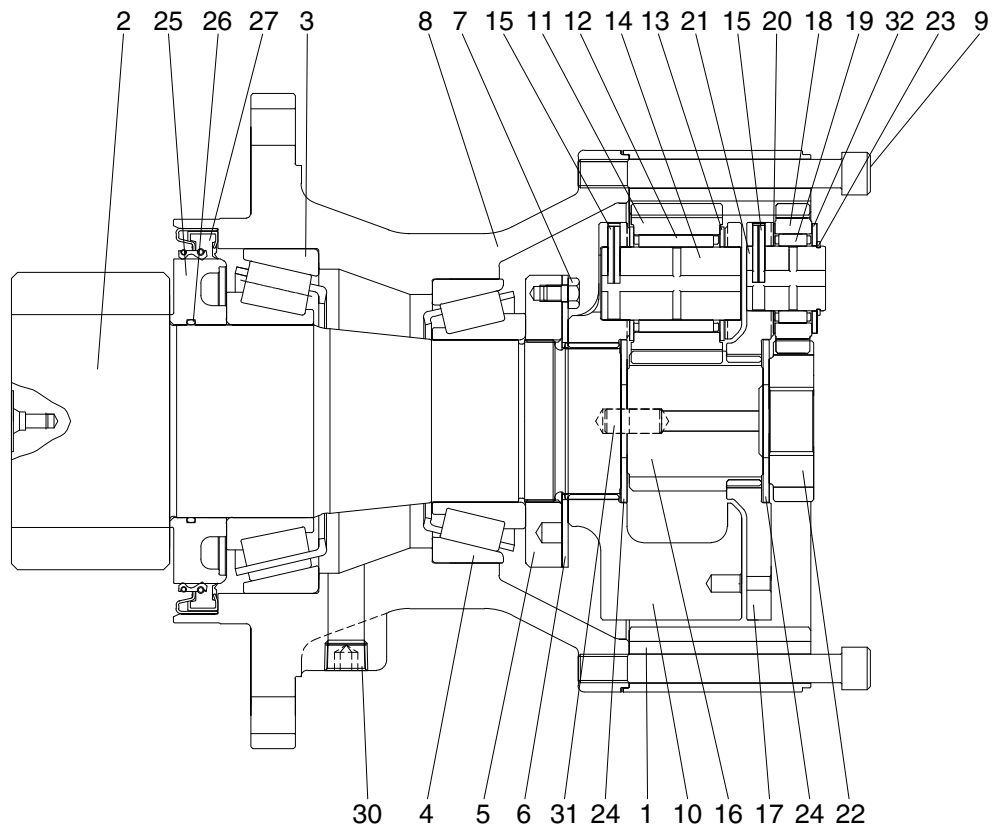

125LCR2SM23

1	Ring gear	11	Planetary gear No. 2	21	Carrier pin No. 1
2	Drive shaft	12	Needle bearing No. 2	22	Sun gear No. 1
3	Taper roller bearing	13	Thrust washer No. 2	23	Snap ring
4	Taper roller bearing	14	Carrier pin No. 2	24	Thrust plate
5	Ring nut	15	Spring pin	25	Sleeve
6	Lock plate	16	Sun gear No. 2	26	O-ring
7	Hexagon bolt	17	Carrier No. 1	27	Oil seal
8	Casing	18	Planetary gear No. 1	30	Plug
9	Socket bolt	19	Needle bearing No. 1	31	Parallel pin
10	Carrier No. 2	20	Thrust washer No. 1	32	Thrust washer No. 1

GROUP 4 TRAVEL DEVICE

1. CONSTRUCTION

Travel device consists travel motor and gear box.

Travel motor includes brake valve, parking brake and high/low speed changeover mechanism.

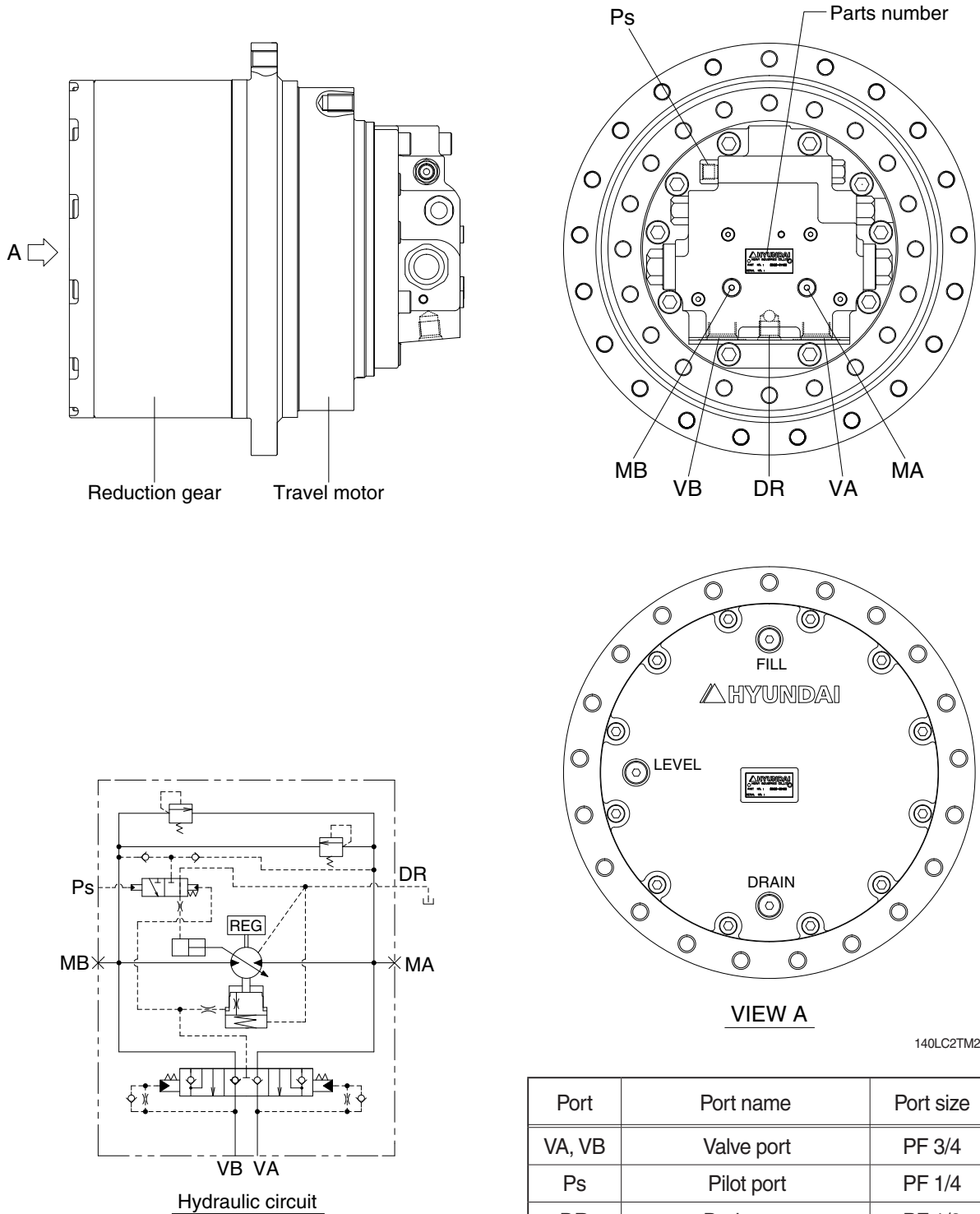

140LC2TM20

Port	Port name	Port size
VA, VB	Valve port	PF 3/4
Ps	Pilot port	PF 1/4
DR	Drain port	PF 1/2
MA, MB	Gauge port	PF 1/4

2. STRUCTURE

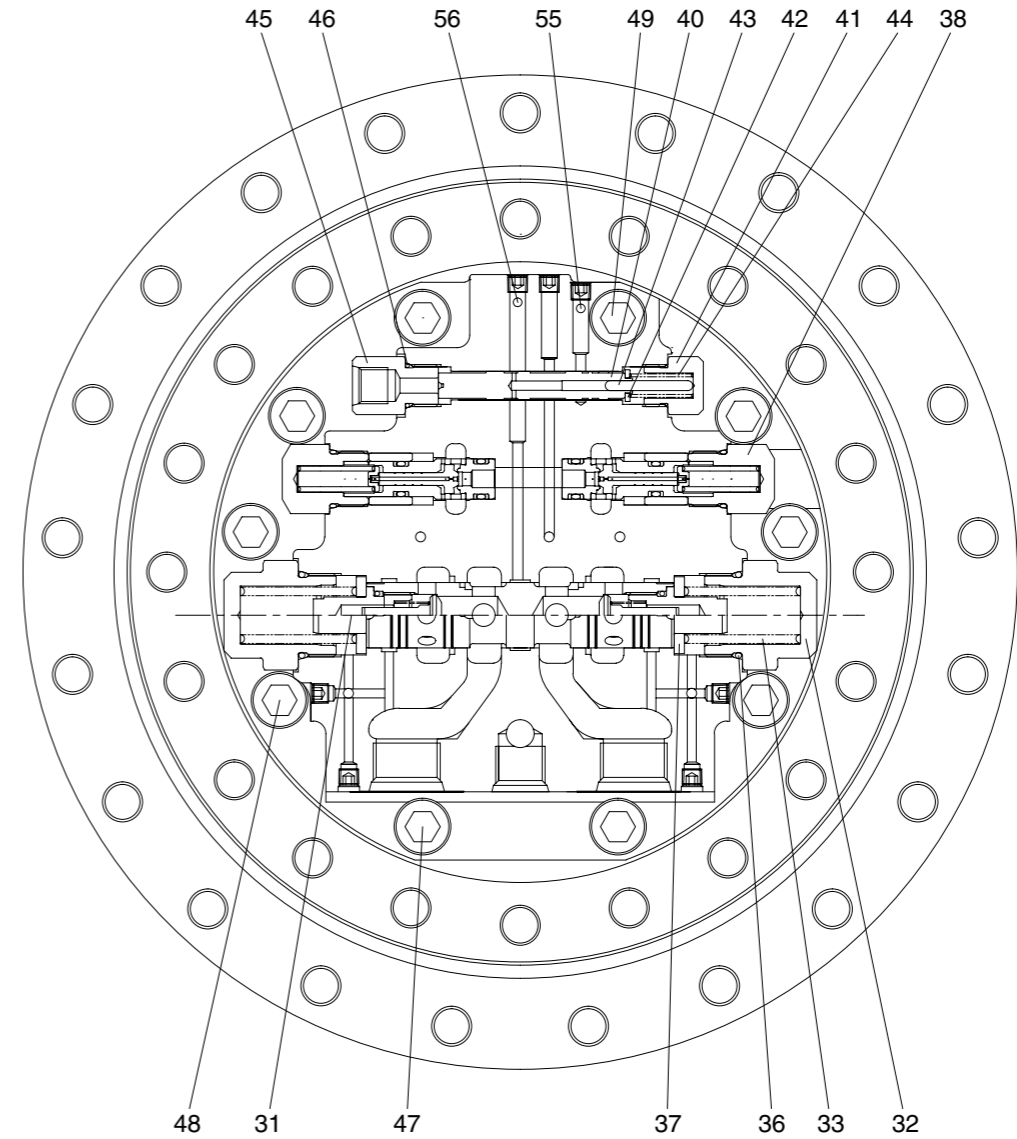
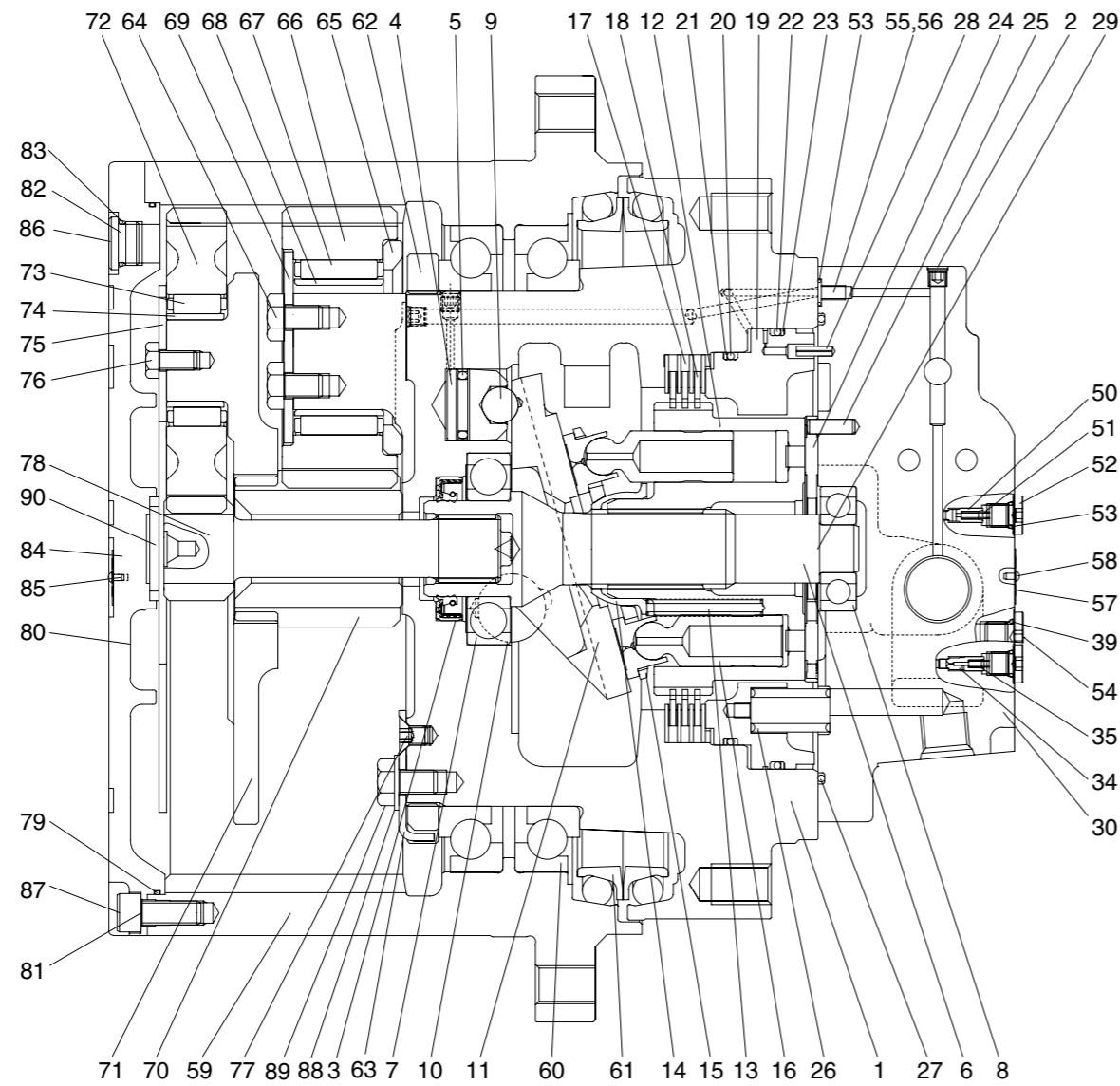

- | | | | | |
|----------------------|--------------------|-----------------------------|------------------------|---------------------------|
| 1 Casing | 19 Parking piston | 37 Spring seat | 55 Restrictor | 73 Needle bearing No.1 |
| 2 Plug | 20 O-ring | 38 Relief valve assy | 56 Restrictor | 74 Inner race No. 1 |
| 3 Oil seal | 21 Back up ring | 39 O-ring | 57 Name plate | 75 Thrust plate No. 1 |
| 4 Piston | 22 O-ring | 40 Spool | 58 Rivet | 76 Hexagon head bolt |
| 5 Piston seal | 23 Back up ring | 41 Plug | 59 Ring gear | 77 Countersunk head screw |
| 6 Shaft | 24 Valve plate | 42 Spring seat | 60 Bearing | 78 Sun gear No.1 |
| 7 Front ball bearing | 25 Spring pin | 43 Parallel pin | 61 Floating seal assy | 79 O-ring |
| 8 Rear ball bearing | 26 Spring | 44 Spring | 62 Nut ring | 80 Cover |
| 9 Steel ball | 27 O-ring | 45 Connector | 63 Lock plate | 81 Hex socket head bolt |
| 10 Pivot | 28 Spring pin | 46 O-ring | 64 Hexagon head bolt | 82 Plug |
| 11 Swash plate | 29 Parallel pin | 47 Hexagon socket head bolt | 65 Thrust plate No. 2 | 83 O-ring |
| 12 Cylinder block | 30 Rear cover | 48 Hexagon socket head bolt | 66 Planetary gear No.2 | 84 Name plate |
| 13 Spring | 31 Main spool assy | 49 Hexagon socket head bolt | 67 Needle bearing No.2 | 85 Rivet |
| 14 Ball guide | 32 Cover | 50 Check valve | 68 Inner race No. 2 | 86 Rubber cap |
| 15 Retainer plate | 33 Spring | 51 Spring | 69 Thrust washer No. 2 | 87 Rubber cap |
| 16 Piston assy | 34 Restrictor | 52 Plug | 70 Sun gear No.2 | 88 Plain washer |
| 17 Friction plate | 35 Spring | 53 O-ring | 71 Carrier No.1 | 89 Hexagon bolt |
| 18 Separated plate | 36 O-ring | 54 Plug | 72 Planetary gear No.1 | 90 Thrust plate |

130ZF2TM21

3. OPERATION

1) MOTOR

High pressure oil delivered from hydraulic pump is led to inlet port that is provided in the brake valve portion and, through the rear cover (30) and valve plate (24), led to cylinder block (12).

The oil flow and direction of shaft rotation are indicated in table.

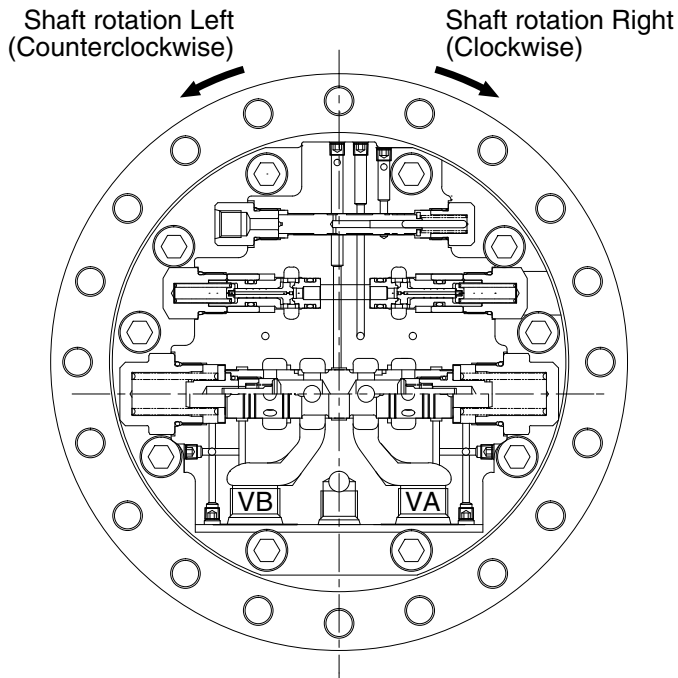

Inlet port	Outlet port	Direction of shaft rotation (viewing from rear cover)
VB	VA	Right (clockwise)
VA	VB	Left (counterclock wise)

125LCR2TM23

As shown in below figure, high pressure oil is supplied to the pistons which are on one side of the line Y-Y that connects upper and lower dead points and produces force F1.

$$F1 = P \times A \quad (P : \text{pressure}, A : \text{area of piston section})$$

The swash plate (11) with inclined angle of α divides this force F1 into thrust force F2 and radial force F31-34.

This radial force is applied to axis Y-Y as turning force and generate drive torque of T.

$$T = r_1 \cdot F31 + r_2 \cdot F32 + r_3 \cdot F33 + r_4 \cdot F34$$

This drive torque is transmitted via cylinder block (12) to driving shaft (6).

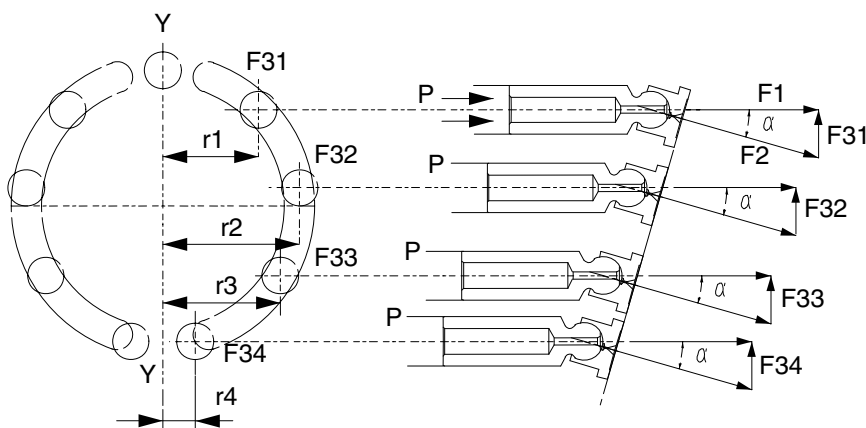

29092TM07

2) PARKING BRAKE

Parking brake is released when high pressure oil selected by the brake valve portion that is connected directly to the rear cover (30), is applied to the parking piston (19).

Otherwise the braking torque is always applied.

This braking torque is generated by the friction between the separated plates (18), inserted into the casing (1), and friction plates (17), coupled to cylinder block (12) by the outer splines.

When no pressure is activated on the parking piston (19), it is pushed by the brake springs (26) and it pushes friction plates (17) and separated plates (18) towards casing (1) and generates the friction force which brakes the rotation of cylinder block (12) and hence the shaft (6).

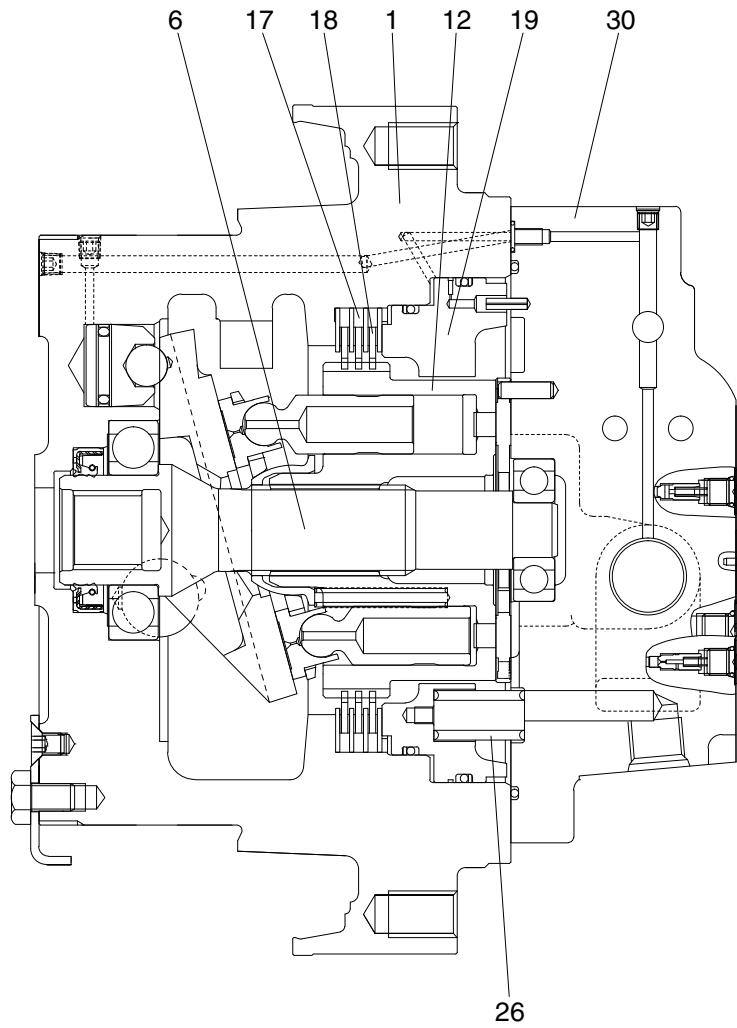

125LCR2TM24

3) CAPACITY CONTROL MECHANISM

Figure typically shows the capacity control mechanism.

When high speed pilot line is charged with the pressure P_A that overcome the spring (44), the spring (44) is compressed and spool (40) shifts to the right to connect the port P and port C.

Then, the highest pressure is selected by the check valve (50) from inlet and outlet pressure of the motor and high speed pilot line pressure and pushes shifter piston (4). As a result, swash plate (11) turns around the line L which connect the two pivot (10) as shown by dotted lines. The turn stops at the stopper (1-1) of casing and swash plate (11) keeps the position.

In this case, the piston stroke become shorter and motor capacity become smaller and motor rotates faster, around 1.60 times, by the same volume of oil.

When no pressure is in the high speed pilot line P_A , spool (40) is pushed back by the spring (44) and pressure that pressed the shifter piston (4) is released to the hydraulic tank through restrictor (55).

Here, nine pistons are there and they equally spaced on the swash plate (11). The force that summed up those of pistons comes to almost the center of the swash plate (11) as shown. Since the steel balls (10) are off-set by S from the center, the rotating force of product S and the force moves swash plate (11) to the former position and the speed returns to low.

When the power demand exceeds the engine power, such as in steep slope climbing or turning at high speed mode, the system step down to the low speed automatically. The mechanism is that: pump pressure is led to the port P_B and this pressure activate on pin (43). When the pressure at P_B exceeds predetermined value, spool (40) returns to the left by the counter-pressure against pin (43) and the pressure on the shifter piston (4) through port C is released to the tank and the motor comes to low speed.

When P_B goes down, the spool (40) moves to the right and the speed become high.

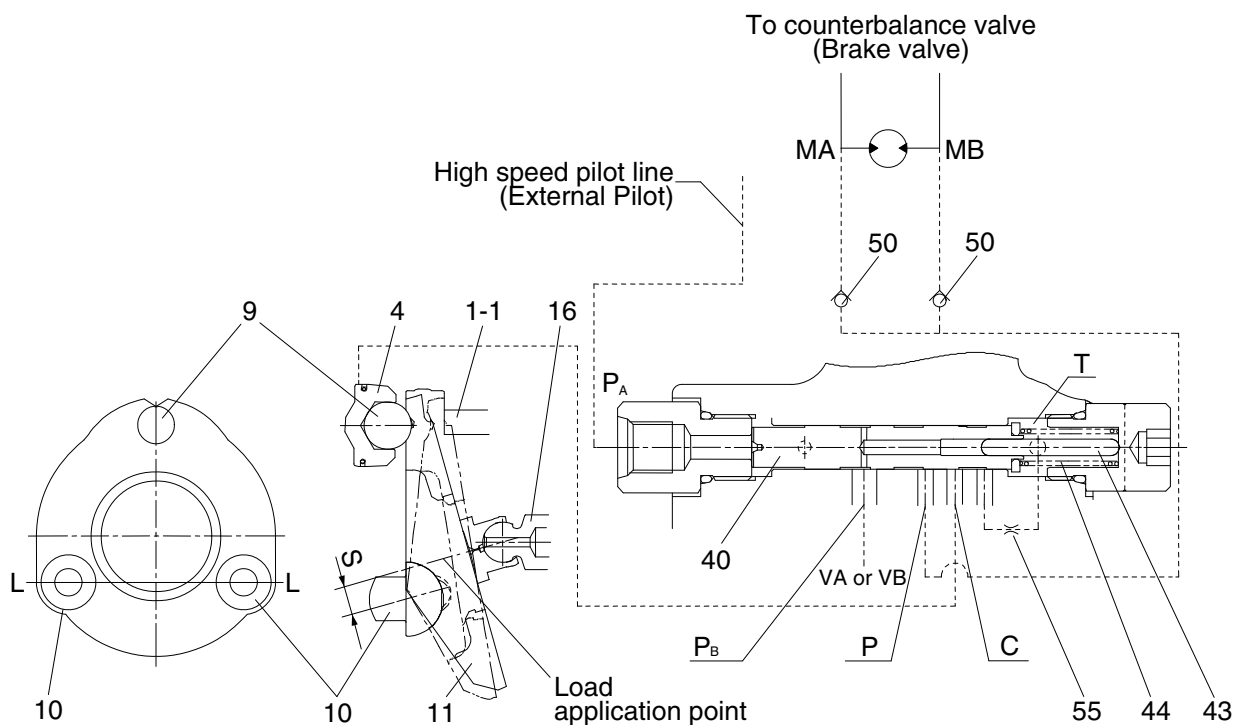

125LCR2TM19

4) OVERLOAD RELIEF VALVE

(1) Structure

This valve is screwed in the motor rear cover (30) and consists of : plug (38-1) that is screwed and fixed in the rear cover (30), poppet (38-8) and supports the poppet seat (38-9), spring (38-2) that is operating relief valve setting pressure and supports the spring seat (38-3), that is inserted in the sleeve (38-4), piston (38-5) that reduce the shock.

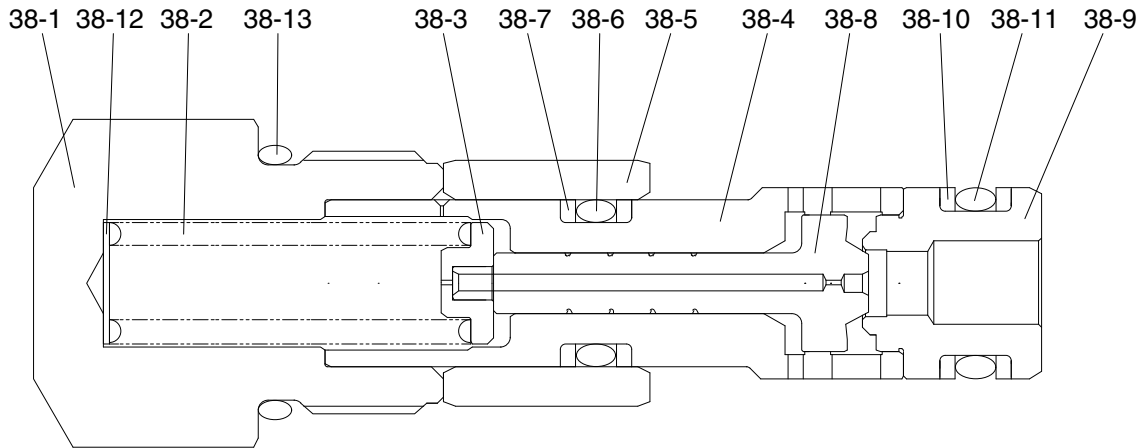

125LCR2TM25

38-1 Plug	38-6 O-ring	38-11 O-ring
38-2 Spring	38-7 Back-up ring	38-12 Ring
38-3 Spring seat	38-8 Poppet	38-13 O-ring
38-4 Sleeve	38-9 Poppet seat	
38-5 Piston	38-10 Back-up ring	

(2) Operation

Two pieces of overload valves are located at cross-over position in the counterbalance circuit of brake valve and have the following functions :

- ① When hydraulic motor starts, keep the driving pressure below predetermined value and while accelerating, bypasses surplus oil to return line.
- ② When stopping the motor, keep the brake pressure, that develops on the outlet side of motor, under the predetermined value to stop the inertial force.
- ③ To accelerate sharply while starting, and to mitigate the braking shock while stopping. For these purposes, the developed pressure is kept comparatively low for a short period, then keep the line pressure as normal value. While the pressure is low, meshing of reduction gears, crawler and sprocket etc. can be smoothly done and the shock are absorbed.

When starting, "A" port pressure of overload valve increases, this pressure is applied to the effective diameter of poppet (38-8) which seats on the poppet seat (38-9) and, at the same time, is delivered, via small hole, to the spring seat (38-3) located inside the sleeve (38-4) and the seat bore pressure increases up to "A" port pressure. The poppet (38-8) opposes to spring (38-2) by the force of the pressure exerted on the area difference between poppet seat's effective diameter and spring seat bore and keep the predetermined pressure.

When hydraulically braking, the piston (38-5) is at the left position by the driving pressure, and when "A" port pressure increases, the pressure is applied also to the piston (38-5) through the small hole in the poppet (38-8), sleeve (38-4) and piston (38-5) moves rightward until it touches the stopper in rear cover. In this while, the poppet (38-8) maintains "A" port pressure at comparatively low against the spring (38-2) force and exhaust oil to "B" port side. After the piston reached to the plug, the valve acts the same as at starting.

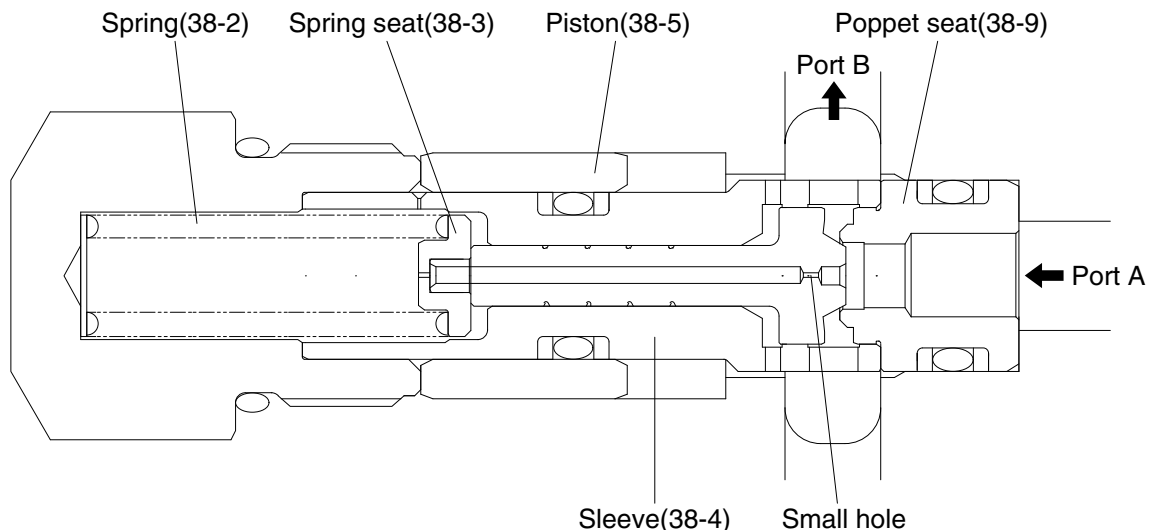

125LCR2TM27

5) BRAKE VALVE

(1) Structure

The brake valve portion mainly consists of the following parts:

① Spool

By shifting the spool (31), the discharged oil from hydraulic motor is automatically shut off or restricted according to the condition and give the effect of holding, accelerating, stopping and counterbalance operations.

(See page 2-67, (2) Operation)

② Check valve (built in the spool)

This valve is located in the oil supplying passage to hydraulic motor, and at the same time functions to lock oil displacement. Therefore, this valve serves as not only a suction valve but also a holding valve for hydraulic motor.

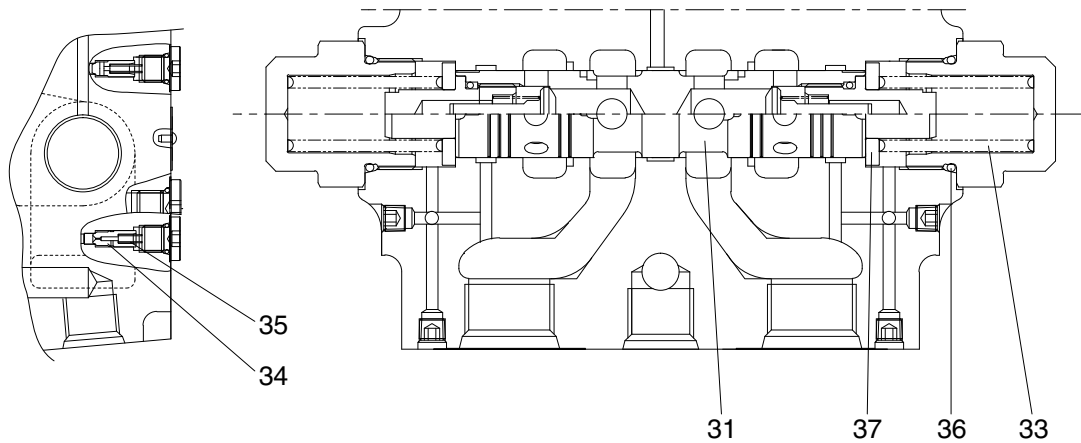

125LCR2TM28

31 Main spool
33 Spring

34 Restrictor
35 Restrictor spring

36 O-ring
37 Spring seat

(2) Operation

① Holding operation

When the control valve is at neutral position, VA and VB ports are connected to the tank, and the spring (33) located on both spool ends holds the spool (31) at central position.

Therefore, the passages from VA to MA and VB to MB are closed, which result in closing MA and MB ports connected to hydraulic motor.

Since the passage to parking brake is connected to the tank line, the brake cylinder pressure is equal to the tank pressure and the brake is applied by the springs. Thus, the rotation of the motor is mechanically prevented.

If external torque is exerted on the motor shaft, the motor would not rotate as usual by this negative parking brake.

In case the brake should be released for some reason, pressure is built on MA or MB port. But, due to oil leakage inside hydraulic motor or so, high-pressure oil escapes from the closed circuit and motor rotates a bit. So, the cavitation tends to occur in the lower pressure side of the closed circuit. Then, the check valve, built in the spool (31), operates to avoid the cavitation and opens the passage from VA to MA or from VB to MB. Then the oil equivalent to the leakage is sucked from the tank line to the closed circuit.

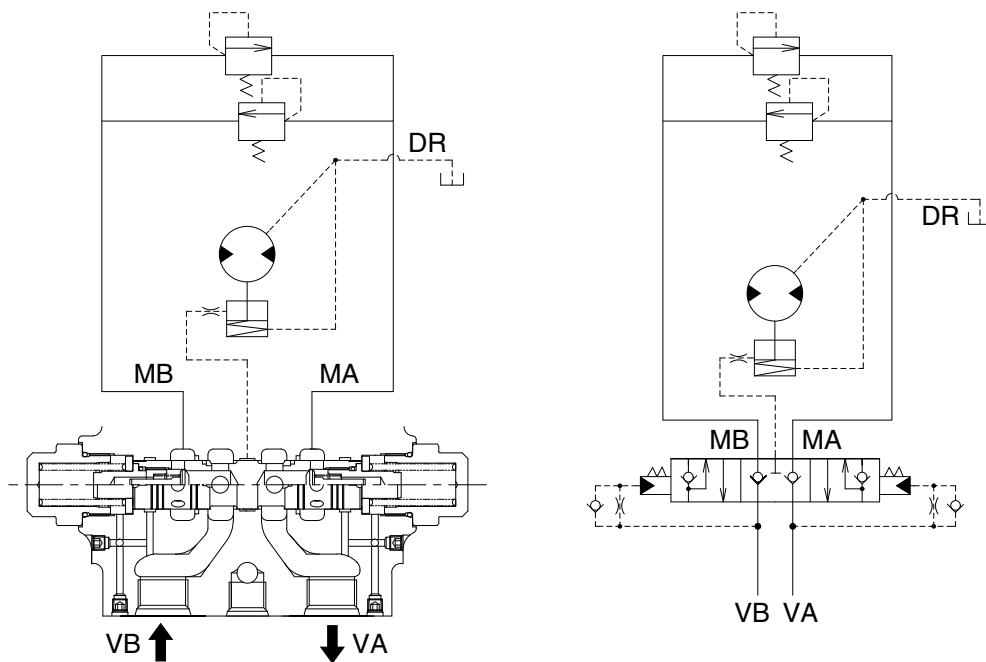

125LCR2TM29

② Accelerating operation

When VA and VB ports are connected respectively to pump and tank by operating the control valve, hydraulic oil from pump is forwarded through VA port to push open the check valve provided inside spool (31), and oil flows to motor via MA port to rotate the motor.

Therefore, the pressure increases and negative brake is released by the pressure supplied from pump. At the same time, the pressure of pilot chamber increases to push and move the spool (31) leftwards, overcoming the spring (33) force. Thus, the return line from MB to VB opens to rotate the motor.

In case inertia load is too big to start rotation, accelerating pressure reaches the set pressure of relief valve and high pressure oil is being relieved while the motor gains the rotational speed.

As the rotational speed goes up, the relieved volume decreases, and finally the motor rotates at a fixed speed.

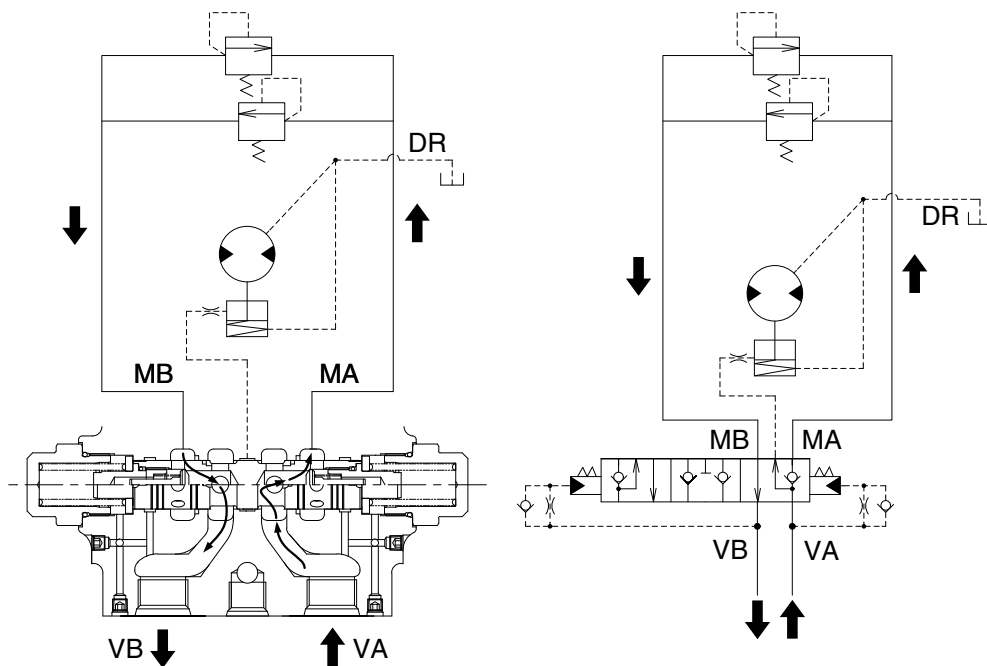

125LCR2TM30

③ Stopping operation

Returning the control valve to neutral position while running the motor, the oil supply is cut off and VA and VB ports are connected to the tank line. Then the pressure of the pilot chamber located on both spool ends become equal, and the spool (31) returns to the neutral position by spring (33) force. Thus, the passage from MA to VA is closed.

Owing to the inertia force of the load, the hydraulic motor tends to continue the rotation. Here, the motor functions as a pump and forwards the oil to MB port but the passage is blocked and MB port pressure increases. Then the relief valve opens to relieve the pressure and rotational speed decelerates and at last the motor stops.

Negative brake release pressure is gradually lowered due to the restrictor and finally the brake works and the motor is mechanically stopped.

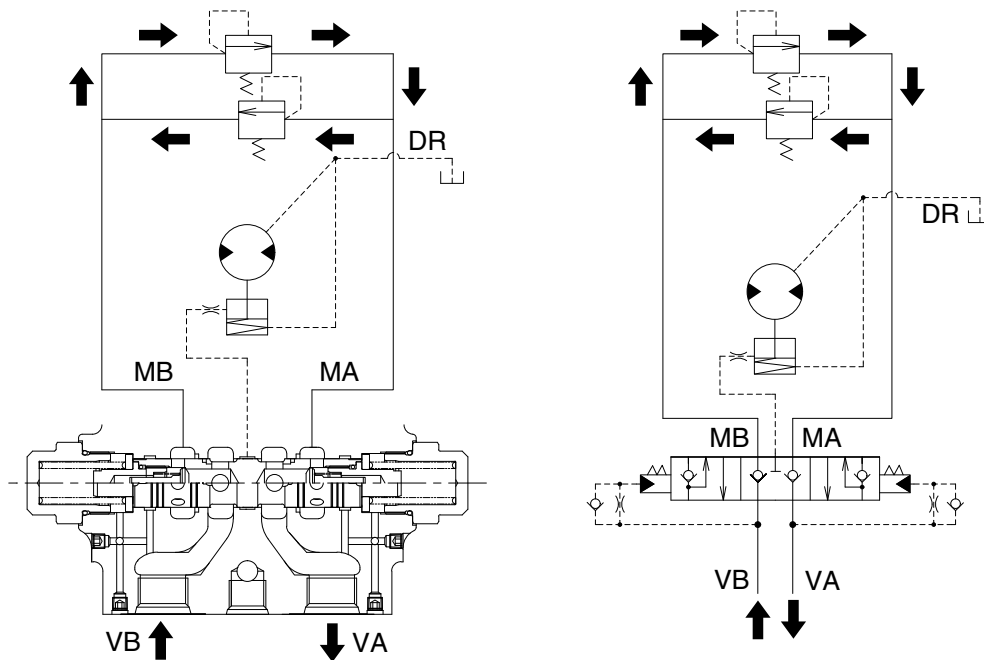

125LCR2TM31

④ Counterbalance operation

Counterbalance operation is required to decelerate slowly the hydraulic motor while absorbing inertia force.

In case the hydraulic oil is gradually decreased from pump to VB port, the drive shaft of hydraulic motor tends to rotate faster than that matched to the volume of oil supply.

Consequently, the pilot chamber pressure on MB to VB side decreases and the spring (33) force moves the spool (31) leftwards towards neutral position.

Therefore, the area of passage from MA to VA becomes smaller and the pressure on MA side rises due to increased resistance in the passage and the motor receives hydraulic braking effect.

If the motor rotates slower than that matched to the volume of supplied oil, the pilot chamber pressure on VB port increases, and spool (31) moves rightwards to enlarge the area of passage from MA to VA. Therefore the braking effect becomes smaller and the rotational speed of motor is controlled to correspond to the volume of supplied oil.

In order to give stable counterbalance operation, the restrictors (34) are set in the pilot chamber to damp the spool (31) movement.

The parking brake is released during pressure adjusting action of the spool (31).

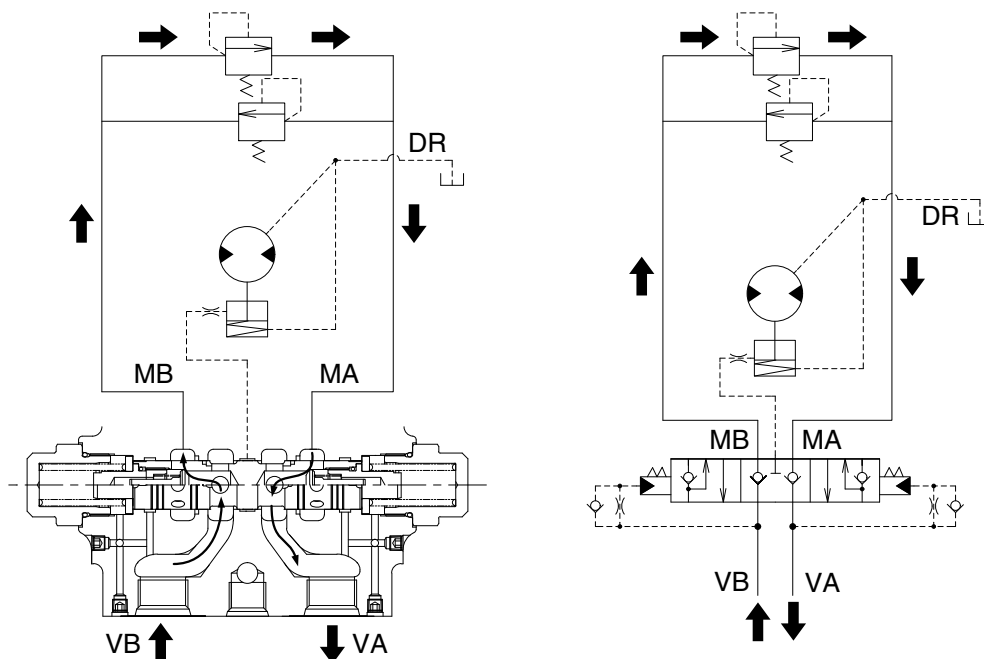

125LCR2TM32

6) REDUCTION GEAR

Reduction unit slows down the rotating speed of motor and converts motor torque to strong rotating force.

This reduction unit utilizes two stages, planetary reduction system.

Planetary reduction system consists of sun gear, planetary gears, (planetary) carriers, and ring gear.

When the sun gear (s) is driven through input shaft, planetary pinions (b), rotating on their center, also move, meshing with fixed ring gear (a), around sun gear (s).

This movement is transferred to carrier (k) and deliver the torque.

This mechanism is called planetary gear mechanism.

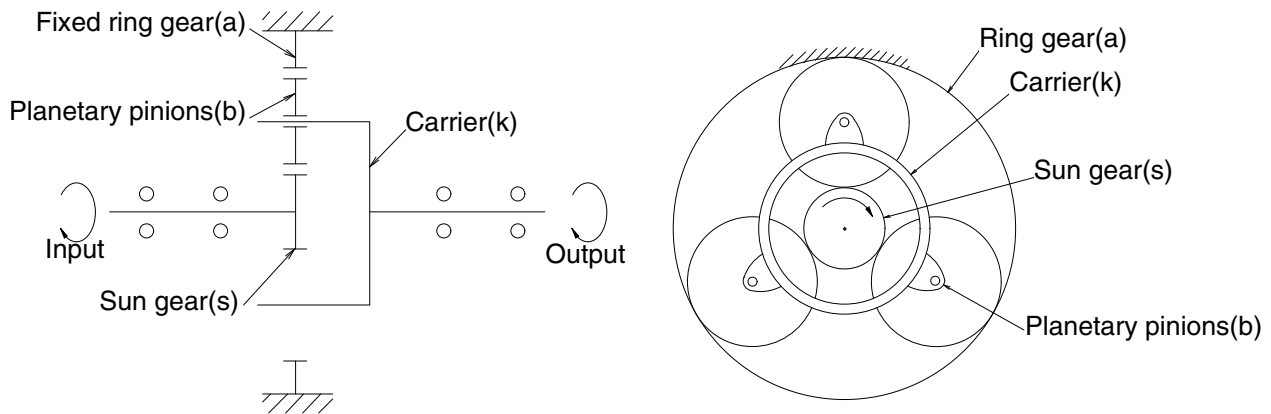

29072TM10

29072TM11

When the sun gear **S1** is driven by input shaft, planetary action occurs among gears **S1**, **a** and **b** and revolution of gear **b** transfers the rotation of carrier **K1** to second sun gear **S2**, and also evokes planetary action between gear **S2**, **a** and **d**.

This time, because carrier **K2** is fixed to frame, gear **d** drives ring gear **a** and then ring gear **a** rotates to drive sprocket.

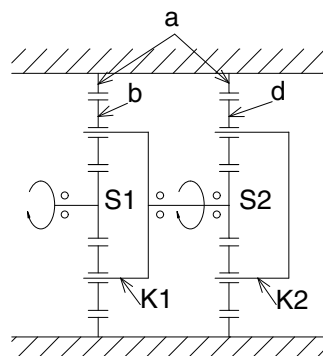

29072TM12

GROUP 5 RCV LEVER

1. STRUCTURE

The casing has the oil inlet port P (primary pressure) and the oil outlet port T (tank). In addition the secondary pressure is taken out through ports 1, 2, 3 and 4 provided at the bottom face.

※ Refer to the parts manual for the types of the RCV lever.

1) TYPE M1, M10

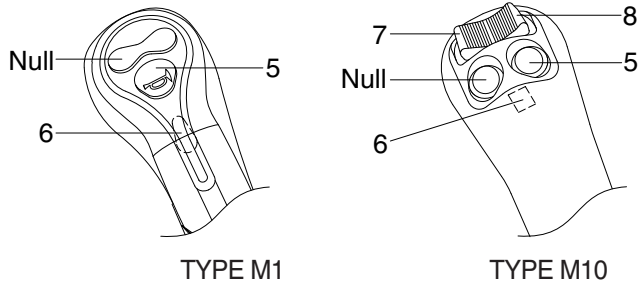
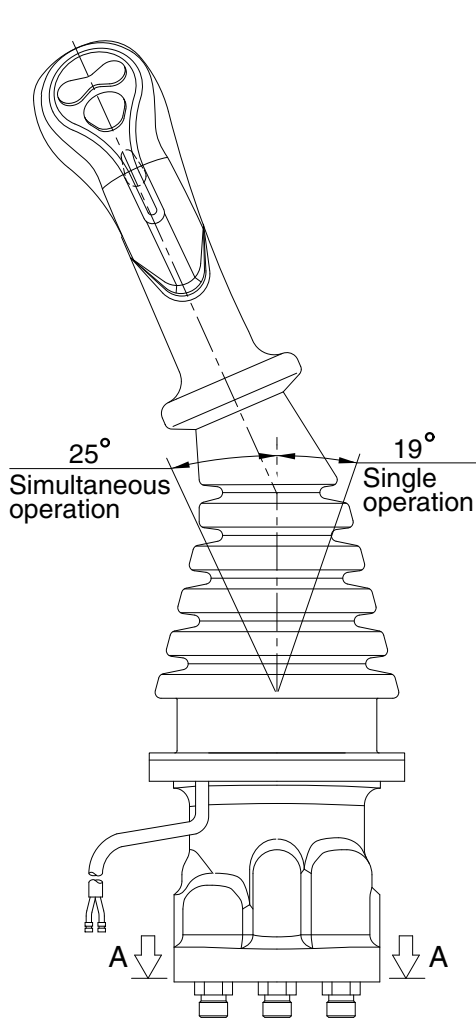

Switches

Type	No.	LH	RH
M1	5	One touch decel	Horn
	6	Power boost	Breaker
M10	5	One touch decel	Horn
	6	Power boost	Null
	7	CCW rotation	Close
	8	CW rotation	Open

※ Number 7 and 8 : Option attachment

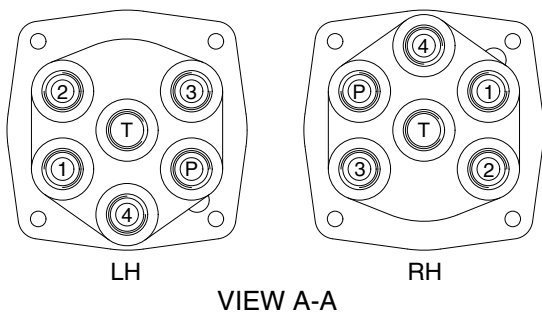
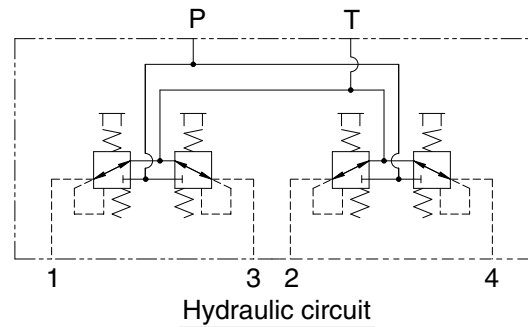

Pilot ports

Port	LH	RH	Port size
P	Pilot oil inlet port	Pilot oil inlet port	PF 3/8
T	Pilot oil return port	Pilot oil return port	
1	Left swing port	Bucket out port	
2	Arm out port	Boom up port	
3	Right swing port	Bucket in port	
4	Arm in port	Boom down port	

235ZF2RL01

2) TYPE M12, M11

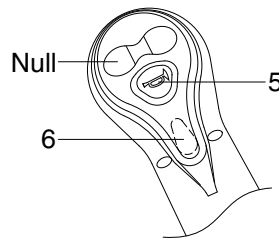
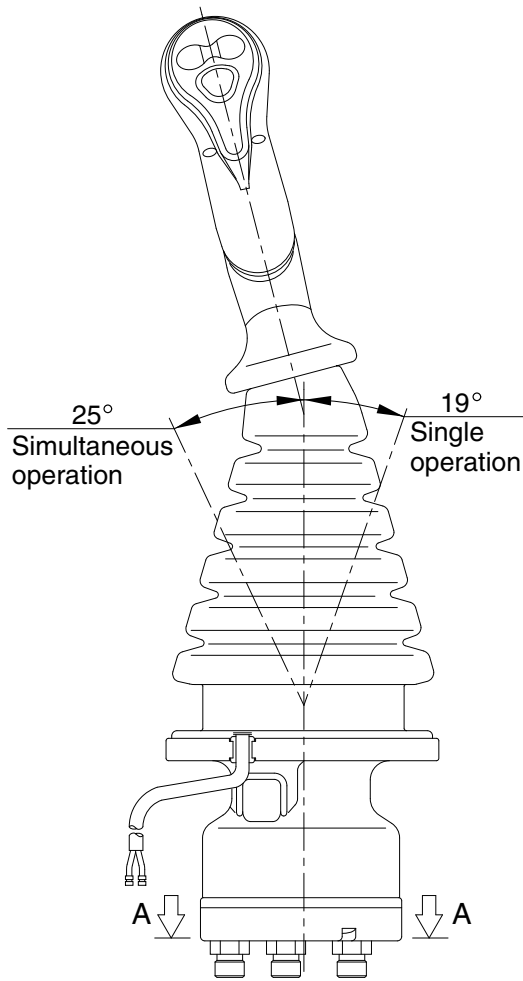

TYPE M12

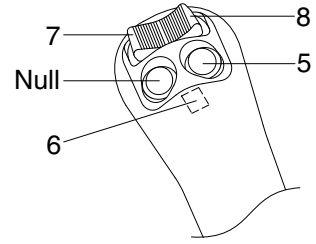

TYPE M11

Switches

Type	No.	LH	RH
M12	5	One touch decel	Horn
	6	Power boost	Breaker
M11	5	One touch decel	Horn
	6	Power boost	Null
	7	CCW rotation	Close
	8	CW rotation	Open

※ Number 7 and 8 : Option attachment

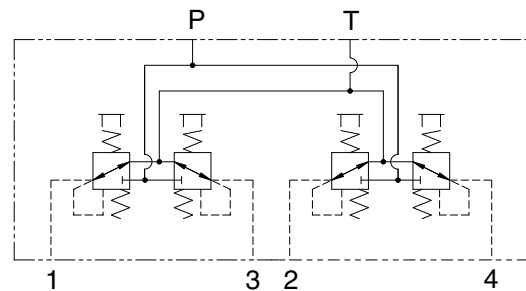

Hydraulic circuit

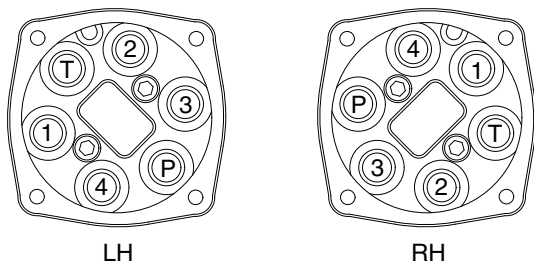

VIEW A-A

Pilot ports

Port	LH	RH	Port size
P	Pilot oil inlet port	Pilot oil inlet port	PF 3/8
T	Pilot oil return port	Pilot oil return port	
1	Left swing port	Bucket out port	
2	Arm out port	Boom up port	
3	Right swing port	Bucket in port	
4	Arm in port	Boom down port	

235ZF2RL05

3) CROSS SECTION

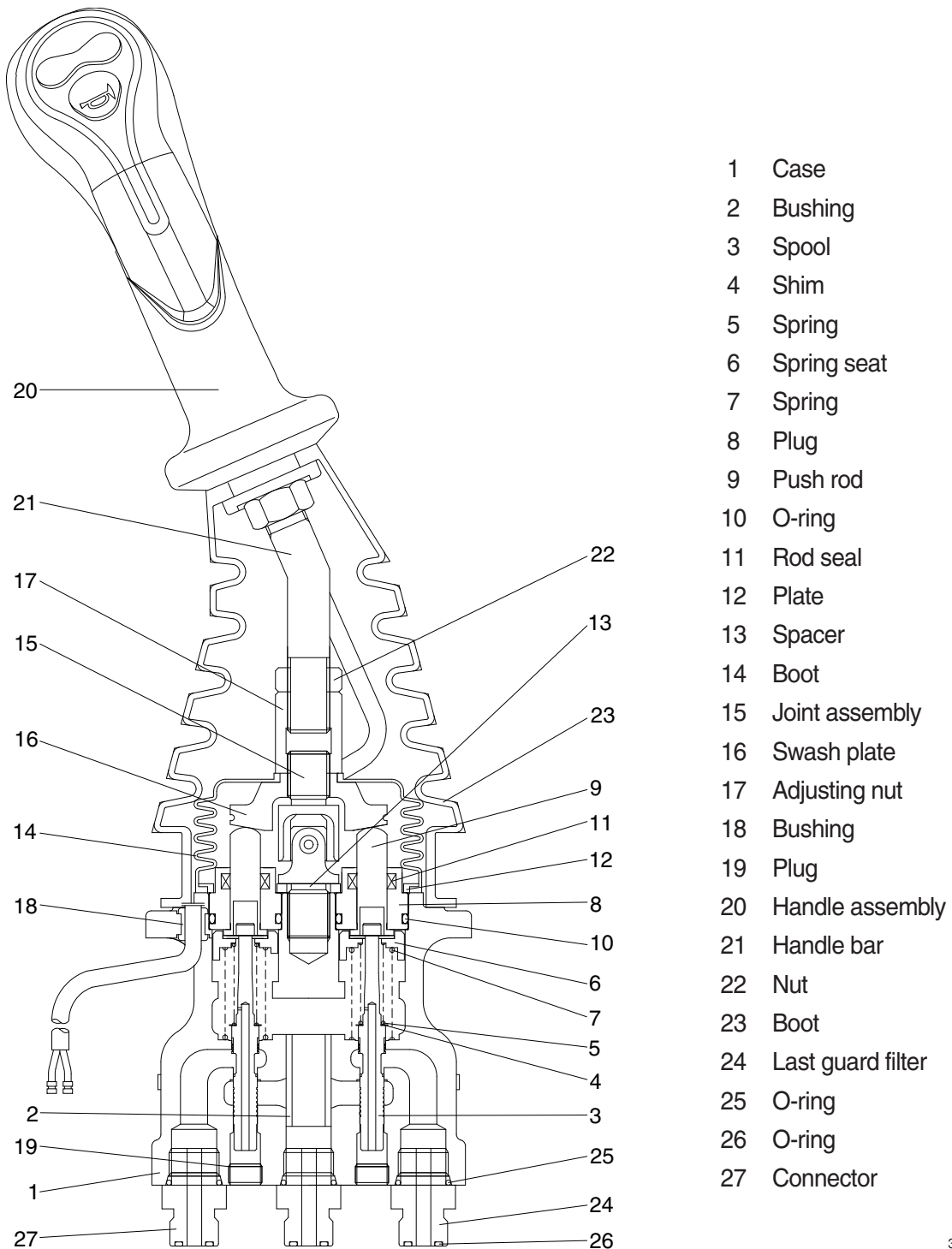

300L2RL06

Item numbers are based on the type M1.

The construction of the pilot valve is shown in the attached cross section drawing. The casing has vertical holes in which reducing valves are assembled.

The pressure reducing section is composed of the spool (3), spring (5) for setting secondary pressure, return spring (7), spring seat (6) and shim (4). The spring for setting the secondary pressure has been generally so preset that the secondary pressure is 5 to 20.5 kgf/cm² (depending on the type). The spool is pushed against the push rod (9) by the return spring.

When the push rod is pushed down by tilting the handle, the spring seat comes down simultaneously and changes setting of the secondary pressure spring.

2. FUNCTIONS

1) FUNDAMENTAL FUNCTIONS

The pilot valve is a valve that controls the spool stroke, direction, etc of a main control valve. This function is carried out by providing the spring at one end of the main control valve spool and applying the output pressure (secondary pressure) of the pilot valve to the other end.

For this function to be carried out satisfactorily, the pilot valve is composed of the following elements.

- (1) Inlet port (P) where oil is supplied from hydraulic pump.
- (2) Output ports (1, 2, 3 & 4) to apply pressure supplied from inlet port to ends of control valve spools.
- (3) Tank port (T) necessary to control the above output pressure.
- (4) Spool to connect output port to inlet port or tank port.
- (5) Mechanical means to control output pressure, including springs that work on the above spools.

2) FUNCTIONS OF MAJOR SECTIONS

Item numbers are based on the type M1.

The functions of the spool (3) are to receive the supply oil pressure from the hydraulic pump at its port P, and to change over oil paths to determine whether the pressure oil of port P is led to output ports 1, 2, 3 & 4 or the output port pressure oil to tank port T.

The spring (5) works on this spool to determine the output pressure.

The change the deflection of this spring, the push rod (9) is inserted and can slide in the plug (8).

For the purpose of changing the displacement of the push rod through the swash plate (16) and adjusting nut (17) are provided the handle assy (20) that can be tilted in any direction around the fulcrum of the universal joint (15) center.

The spring (7) works on the case (1) and spring seat (6) and tries to return the push rod (9) to the zero-displacement position irrespective of the output pressure, securing its resetting to the center position.

This also has the effect of a reaction spring to give appropriate control feeling to the operator.

3) OPERATION

The operation of the pilot valve will be described on the basis of the hydraulic circuit diagram shown below and the attached operation explanation drawing.

The diagram shown below is the typical application example of the pilot valve.

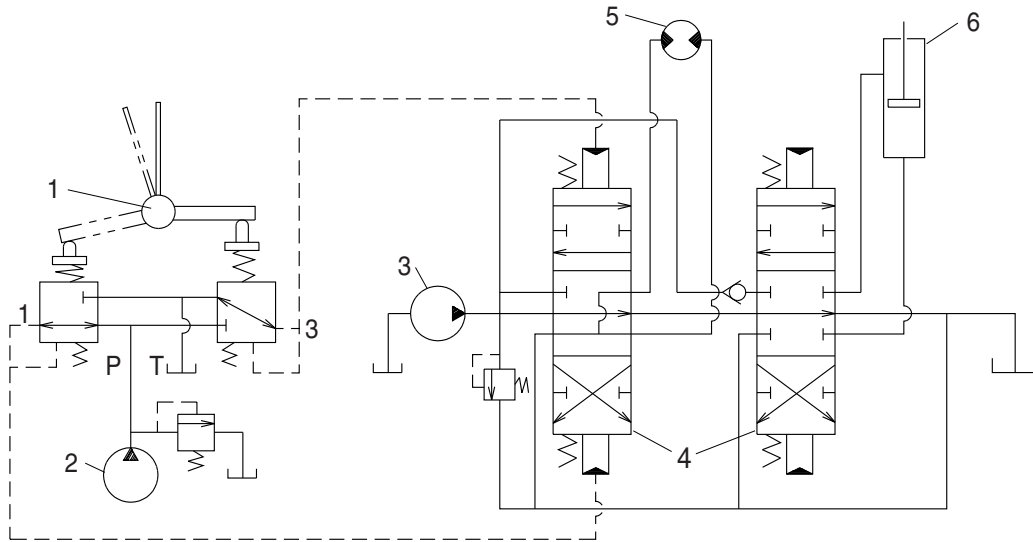

2-70

- 1 Pilot valve
- 2 Pilot pump

- 3 Main pump
- 4 Main control valve

- 5 Hydraulic motor
- 6 Hydraulic cylinder

(1) Case where handle is in neutral position

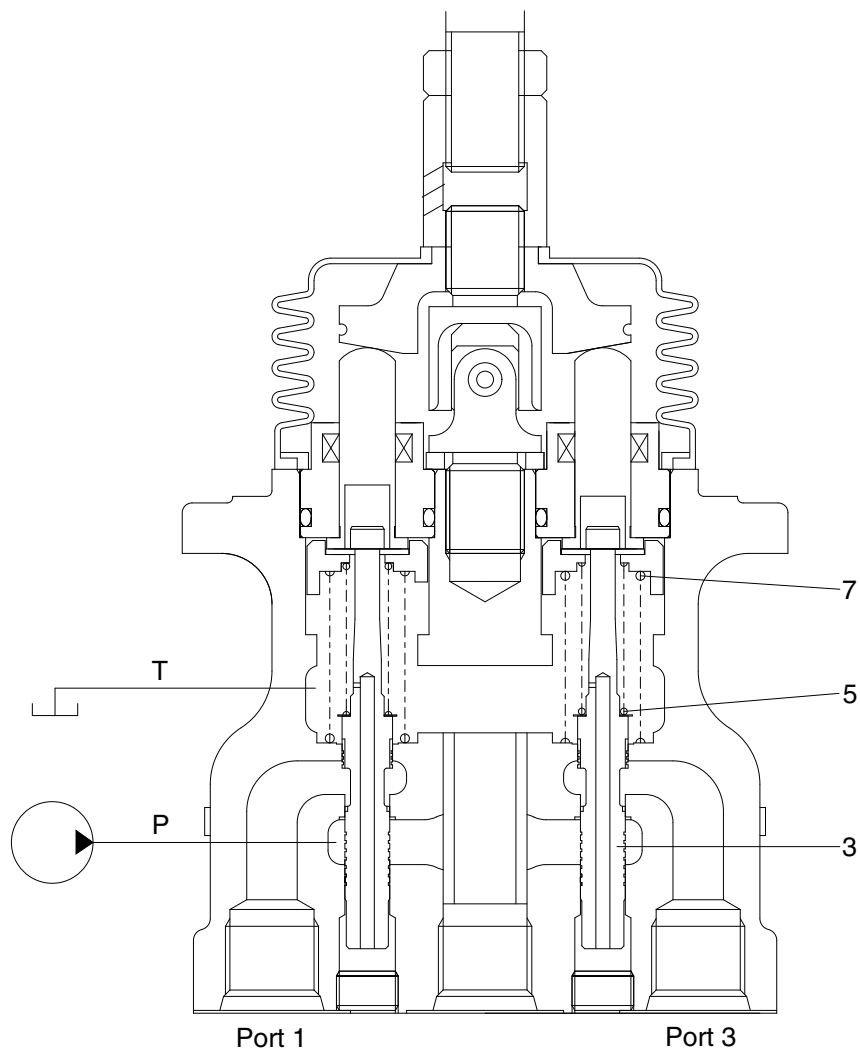

300L2RL03

The force of the spring (5) that determines the output pressure of the pilot valve is not applied to the spool (3). Therefore, the spool is pushed up by the spring (7) to the position of port (1, 3) in the operation explanation drawing. Then, since the output port is connected to tank port T only, the output port pressure becomes equal to tank pressure.

(2) Case where handle is tilted

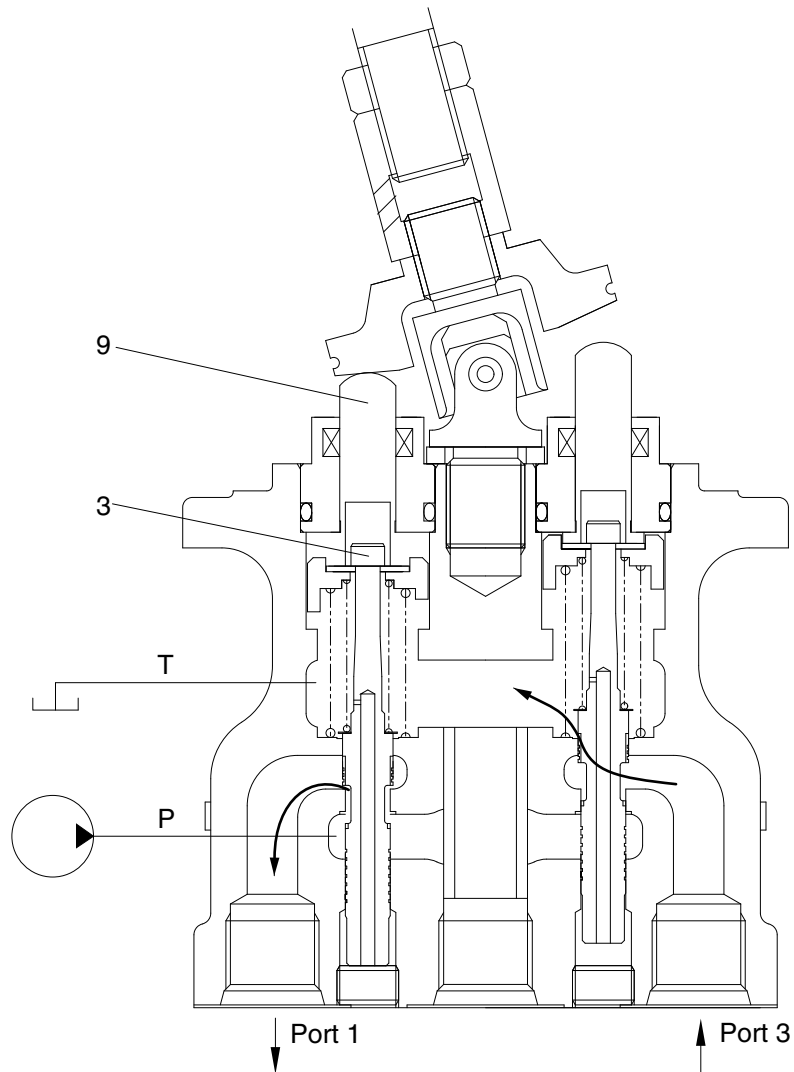

300L2RL04

When the push rod (9) is stroked, the spool (3) moves downwards.

Then port P is connected with port (1) and the oil supplied from the pilot pump flows through port (1) to generate the pressure.

When the pressure at port (1) increases to the value corresponding to the spring force set by tilting the handle, the hydraulic pressure force balances with the spring force. If the pressure at port (1) increases higher than the set pressure, port P is disconnected from port (1) and port T is connected with port (1). If it decreases lower than the set pressure, port P is connected with port (1) and port T is disconnected from port 1.

In this manner the secondary pressure is kept at the constant value.

Besides, in some type, when the handle is tilted more than a certain angle, the upper end of the spool contacts with the inside bottom of the push rod and the output pressure is left to be connected with port P.

GROUP 6 RCV PEDAL

1. STRUCTURE

The casing (spacer) has the oil inlet port P (primary pressure), and the oil outlet port T (tank). In addition the secondary pressure is taken out through ports 1, 2, 3 and 4 provided at the bottom face.

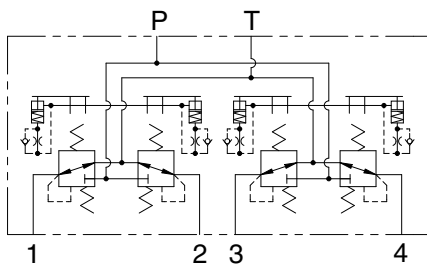
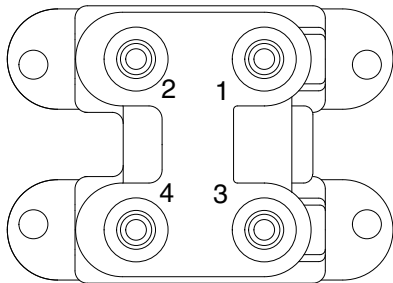
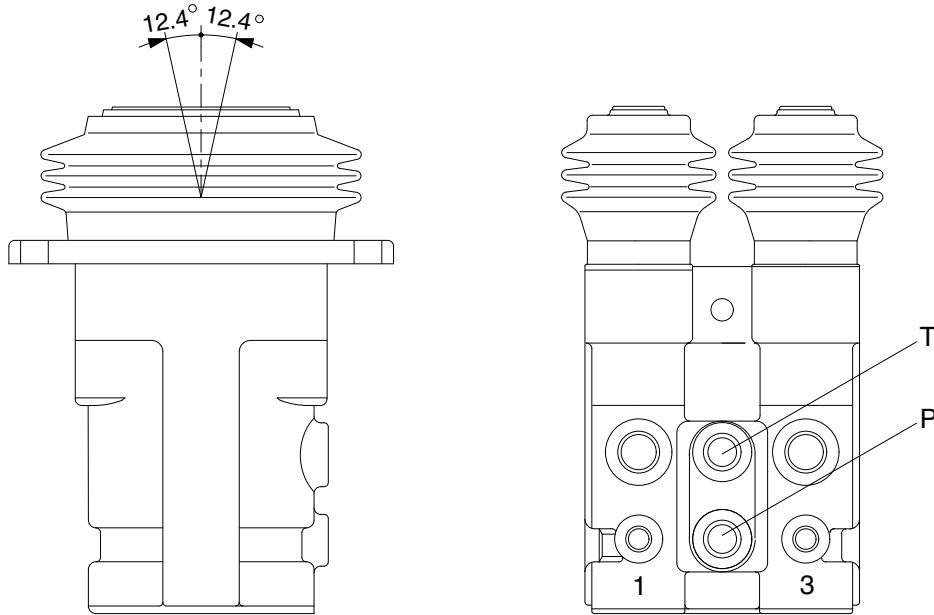

Hydraulic circuit

Port	Port	Port size
P	Pilot oil inlet port	PF 1/4
T	Pilot oil return port	
1	Travel (LH, Forward)	
2	Travel (LH, Backward)	
3	Travel (RH, Forward)	
4	Travel (RH, Backward)	

130ZF2RP01

CROSS SECTION

The construction of the RCV pedal is shown in the below drawing. The casing has vertical holes in which reducing valves are assembled.

The pressure reducing section is composed of the spool (7), spring (5) for setting secondary pressure, return spring (9), stopper (8), and spring seat (6). The spring for setting the secondary pressure has been generally so preset that the secondary pressure is 6.3 ± 1 to 24.9 ± 1.5 kgf/cm² (depending on the type). The spool is pushed against the push rod (13) by the return spring.

When the push rod is pushed down by tilting pedal, the spring seat comes down simultaneously and changes setting of the secondary pressure spring.

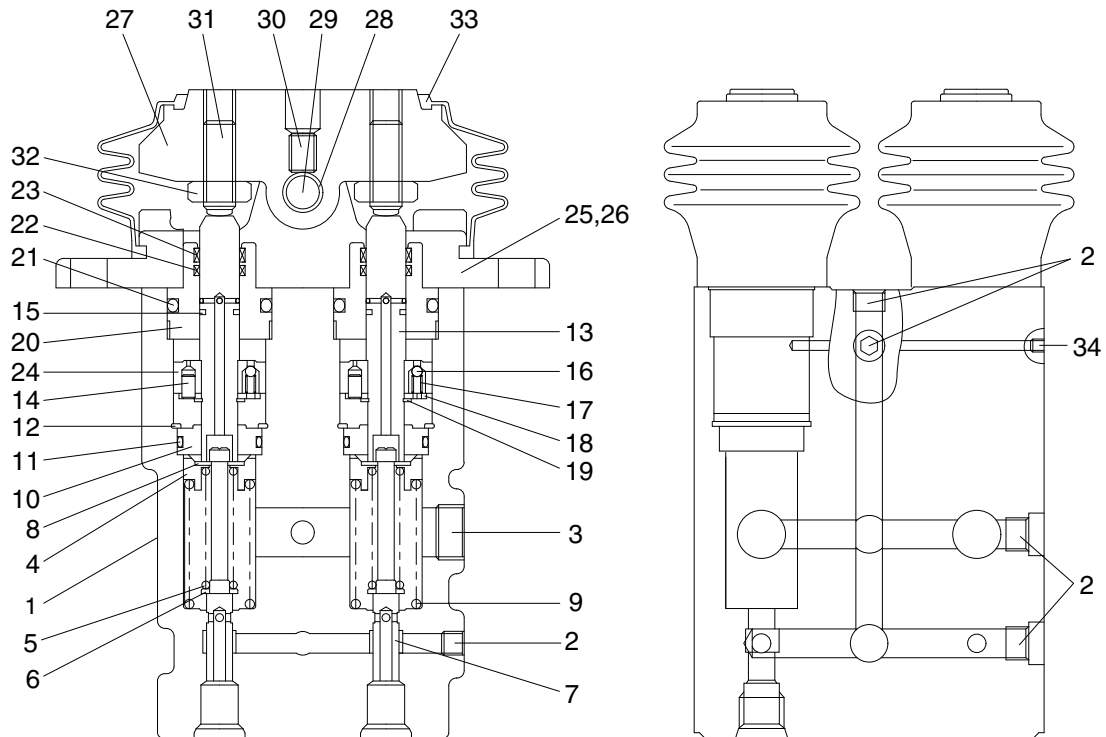

1	Body	13	Push rod	25	Cover
2	Plug	14	Spring pin	26	Socket bolt
3	Plug	15	Seal	27	Cam
4	Spring seat	16	Steel ball	28	Bushing
5	Spring	17	Spring	29	Cam shaft
6	Spring seat	18	Plate	30	Set screw
7	Spool	19	Snap ring	31	Set screw
8	Stopper	20	Plug	32	Hex nut
9	Spring	21	O-ring	33	Bellows
10	Rod guide	22	Rod seal	34	Expand
11	O-ring	23	Dust seal	35	Name plate
12	Snap ring	24	Piston		

130ZF2RP02

2. FUNCTION

1) FUNDAMENTAL FUNCTIONS

The pilot valve is a valve controls the spool stroke, direction, etc of a main control valve. This function is carried out by providing the spring at one end of the main control valve spool and applying the output pressure (secondary pressure) of the pilot valve to the other end.

For this function to be carried out satisfactorily, the pilot valve is composed of the following elements.

- (1) Inlet port (P) where oil is supplied from hydraulic pump.
- (2) Output port (1, 2, 3 & 4) to apply pressure supplied from inlet port to ends of control valve spools.
- (3) Tank port (T) necessary to control the above output pressure.
- (4) Spool to connect output port to inlet port tank port.
- (5) Mechanical means to control output pressure, including springs that work on the above spools.

2) FUNCTIONS OF MAJOR SECTIONS

The functions of the spool (8) are to receive the supply oil pressure from the hydraulic pump at its port P, and to change over oil paths to determine whether the pressure oil of port P is led to output ports 1, 2, 3 & 4 or the output spool to determine the output pressure.

The spring (6) works on this spool to determine the output pressure.

The change the deflection of this spring, the push rod (13) is inserted and can slide in the plug (20). For the purpose of changing th displacement of the push rod through the cam (27) and adjusting nut (32) are provided the pedal that can be tilted in any direction around the fulcrum of the cam (27) center.

The spring (9) works on the body (1) and spring seat (6) and tries to return the push rod (13) to the zero-displacement position irrespective of the output pressure, securing its resetting to the center position.

This also has the effect of a reaction spring to give appropriate control feeling to the operator.

3) OPERATION

The operation of the pilot valve will be described on the basis of the hydraulic circuit diagram shown below and the attached operation explanation drawing.

The diagram shown below is the typical application example of the pilot valve.

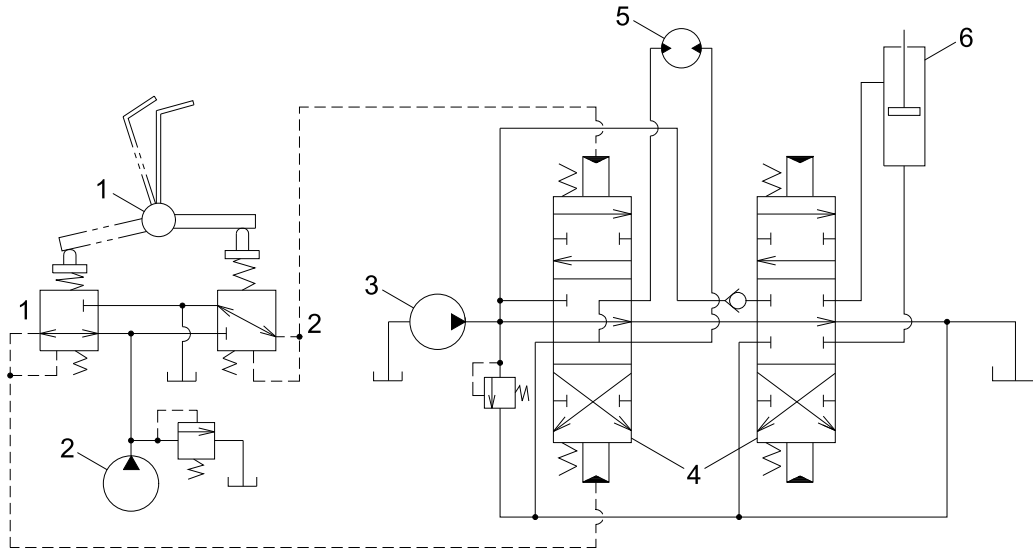

36072SF01

1 Pilot valve
2 Pilot pump

3 Main pump
4 Main control valve

5 Hydraulic motor
6 Hydraulic cylinder

(1) Case where pedal is in neutral position

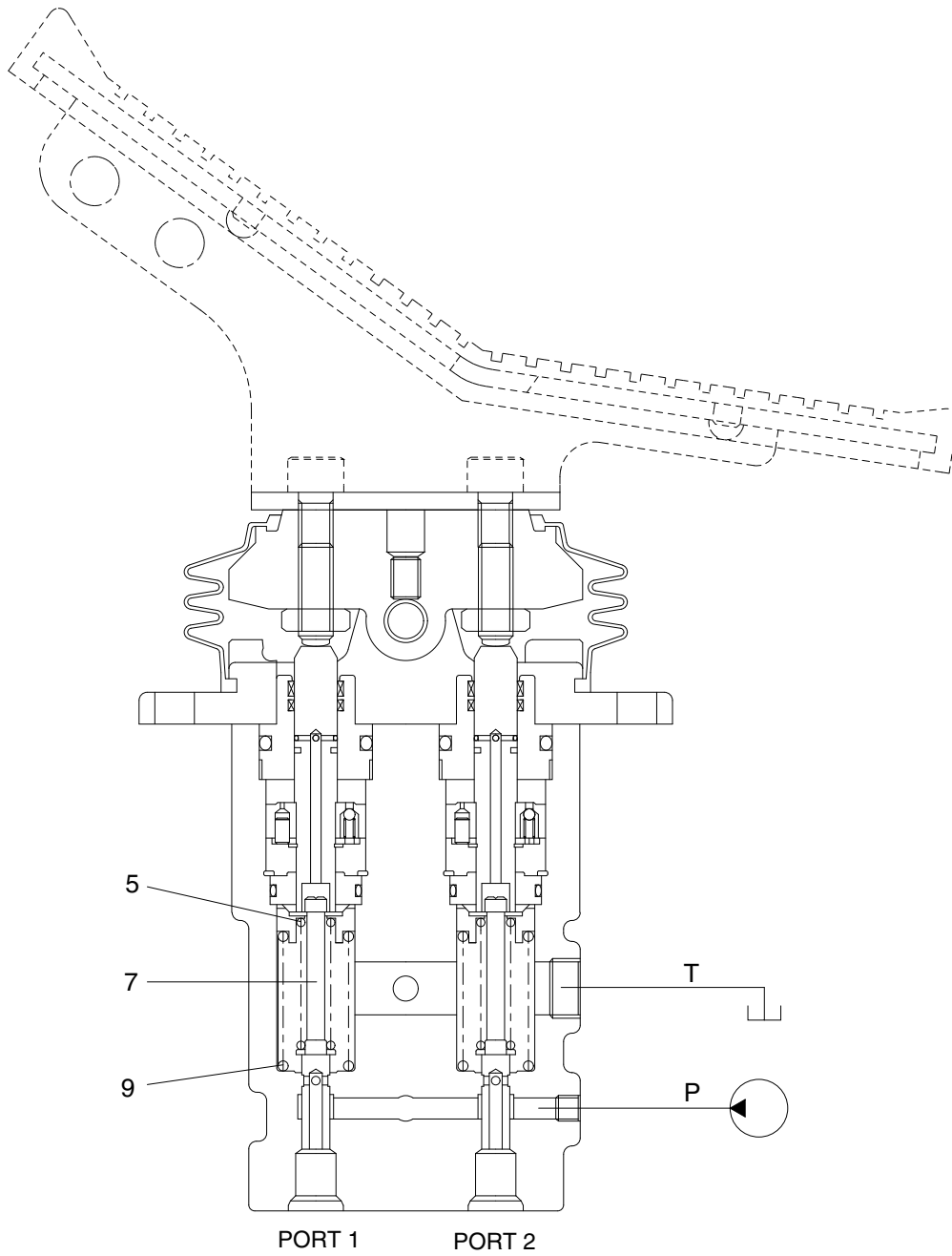

220SA2RP03

The force of the spring (5) that determines the output pressure of the pilot valve is not applied to the spool (7). Therefore, the spool is pushed up by the spring (9) to the position of port 1 and 2. Then, since the output port is connected to tank port T only, the output port pressure becomes equal to tank pressure.

(2) Case where pedal is tilted

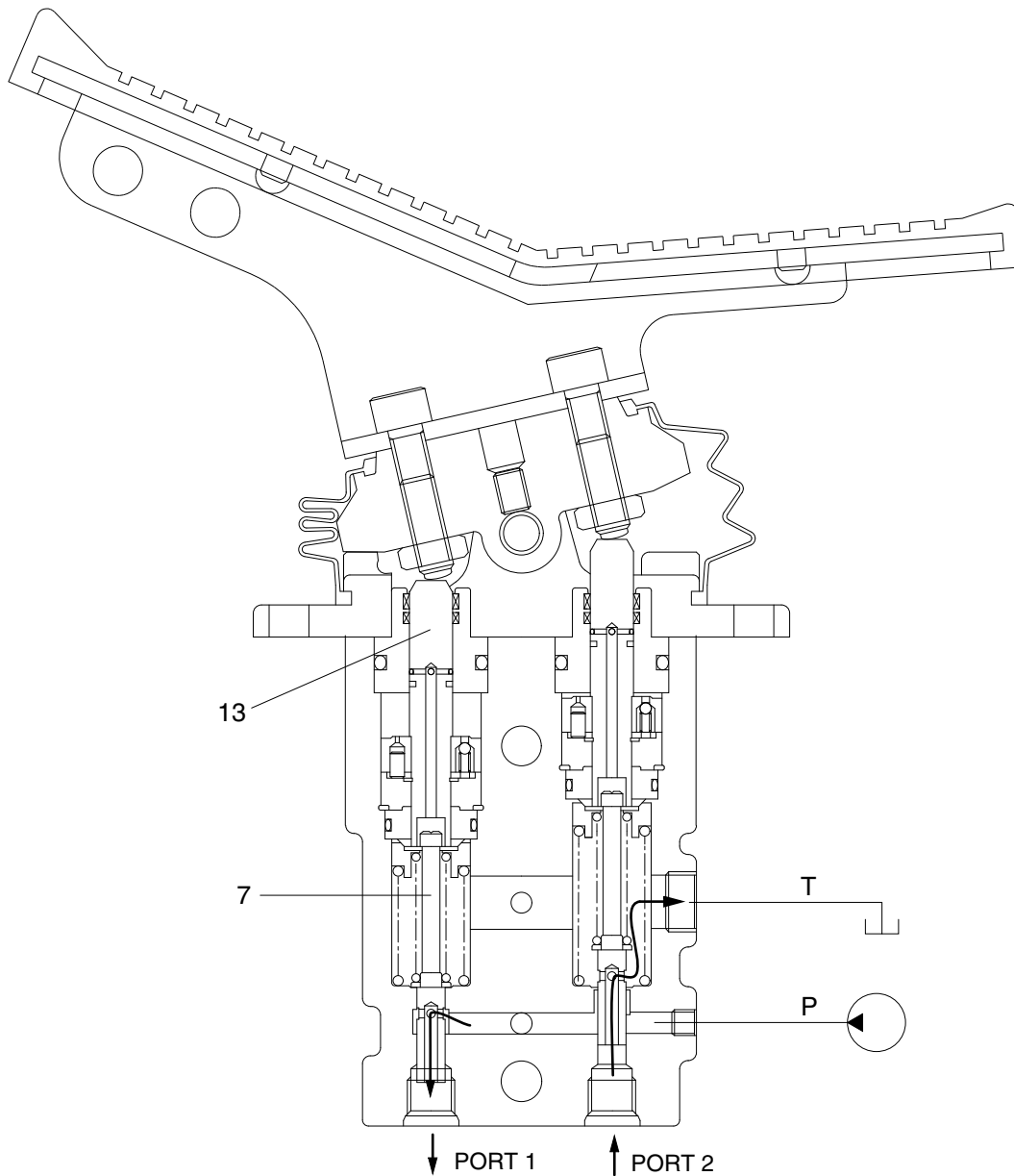

220SA2RP04

When the push rod (13) is stroked, the spool (7) moves downwards.

Then port P is connected with port 1, and the oil supplied from the pilot pump flows through port 1 to generate the pressure.

When the pressure at port 1 increases to the value corresponding to the spring force set by tilting the handle, the hydraulic pressure force balances with the spring force. If the pressure at port 1 increases higher than the set pressure, port P is disconnected from port 1 and port T is connected with port 1. If it decreases lower than the set pressure, port P is connected with port 1 and port T is disconnected from port 1.

In this manner the secondary pressure is kept at the constant value.

Besides, in some type, when the handle is tilted more than a certain angle, the upper end of the spool contacts with inside bottom of the push rod and the output pressure is left to be connected with port P.