

## SECTION 3 HYDRAULIC SYSTEM

Group 1 Hydraulic Circuit .....	3-1
Group 2 Main Circuit .....	3-2
Group 3 Pilot Circuit .....	3-5
Group 4 Single Operation .....	3-15
Group 5 Combined Operation .....	3-27

GROUP 1 HYDRAULIC CIRCUIT

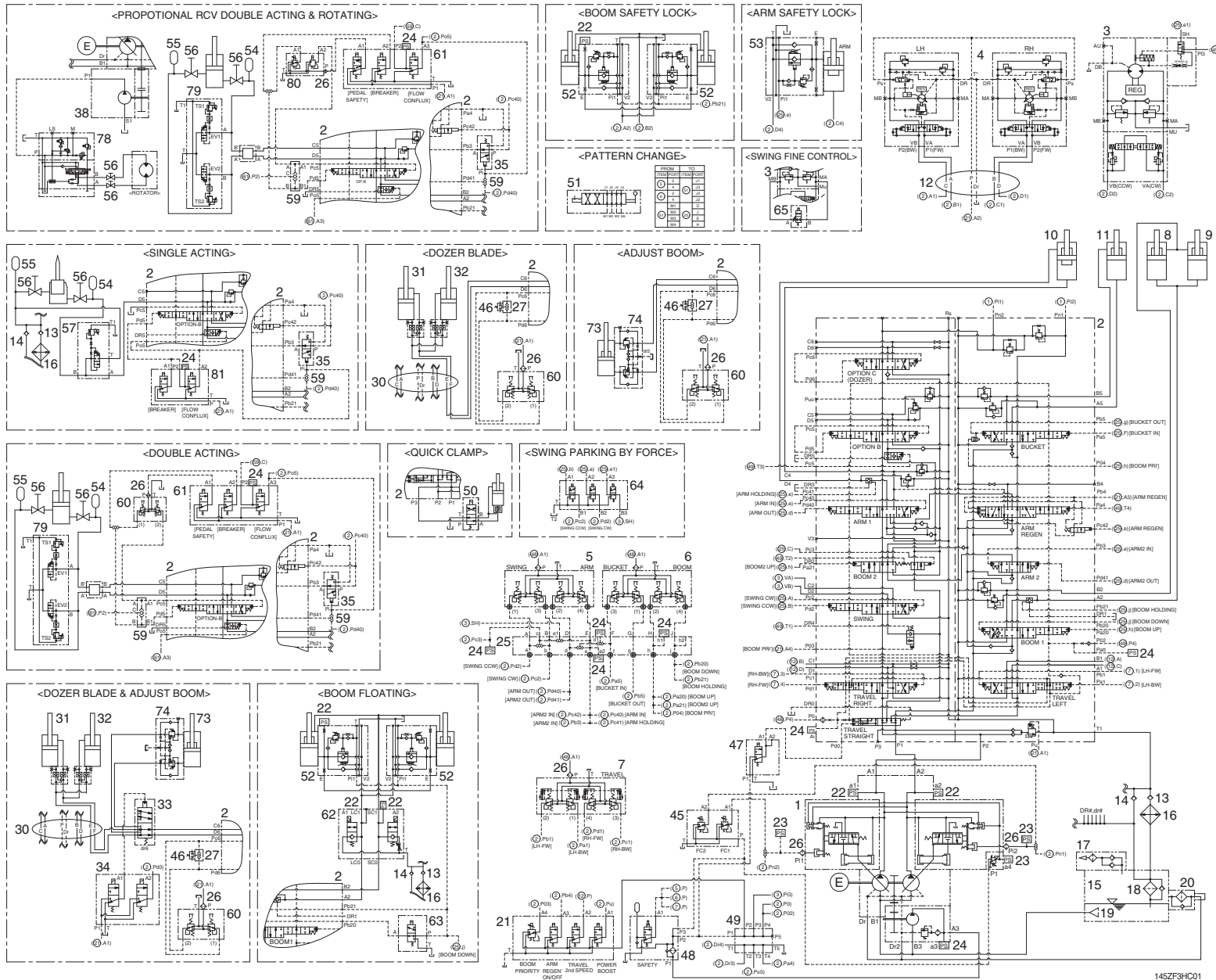

- 1 Main pump
- 2 Main control valve
- 3 Swing motor
- 4 Travel motor
- 5 RCV lever(LH)
- 6 RCV lever(RH)
- 7 RCV pedal
- 8 Boom cylinder(LH)
- 9 Boom cylinder(RH)
- 10 Arm cylinder
- 11 Bucket cylinder
- 12 Turning joint
- 13 Check valve
- 14 Check valve
- 15 Hydraulic tank
- 16 Oil cooler
- 17 Air breather
- 18 Return filter
- 19 Suction strainer
- 20 Drain filter
- 21 4 cartridge valve
- 22 Pressure sensor
- 23 Pressure sensor
- 24 Pressure sensor
- 25 Shuttle block
- 26 Last guard filter
- 27 Shuttle valve(option)
- 28 Turning joint(option)
- 29 Turning joint(option)
- 30 Dozer cylinder(LH, option)
- 31 Dozer cylinder(RH, option)
- 32 Selector valve(option)
- 33 Solenoid valve(option)
- 34 Solenoid valve(option)
- 35 Pilot selector valve(option)
- 36 Gear pump(option)
- 38 Solenoid valve(option)
- 44 Solenoid valve(option)
- 45 2 EPPR cartridge valve(option)
- 46 Pressure switch(option)
- 47 Solenoid valve(option)
- 48 1 cartridge valve
- 49 Block
- 50 Solenoid valve(option)
- 51 Pattern change valve(option)
- 52 Boom safety valve(option)
- 53 Arm safety valve(option)
- 54 Accumulator(option)
- 55 Accumulator(option)
- 56 Stop valve(option)
- 57 Proportional relief valve(option)
- 59 Shuttle valve(option)
- 60 2 way pedal(option)
- 61 Solenoid valve(option)
- 62 Float cartridge valve(option)
- 63 Solenoid valve(option)
- 64 Solenoid valve(option)
- 65 Solenoid valve(option)
- 73 Adjust boom cylinder(option)
- 78 Proportional valve(option)
- 79 Proportional relief valve(option)
- 80 2 EPPR valve(option)
- 81 Solenoid valve(option)

## GROUP 2 MAIN CIRCUIT

The main hydraulic circuit consists of suction circuit, delivery circuit, return circuit and drain circuit. The hydraulic system consists of one main pump, one control valve, one swing motor, four cylinders and two travel motors.

The swash plate type variable displacement axial piston pump is used as the main pump and is driven by the engine at ratio 1.0 of engine speed.

### 1. SUCTION AND DELIVERY CIRCUIT

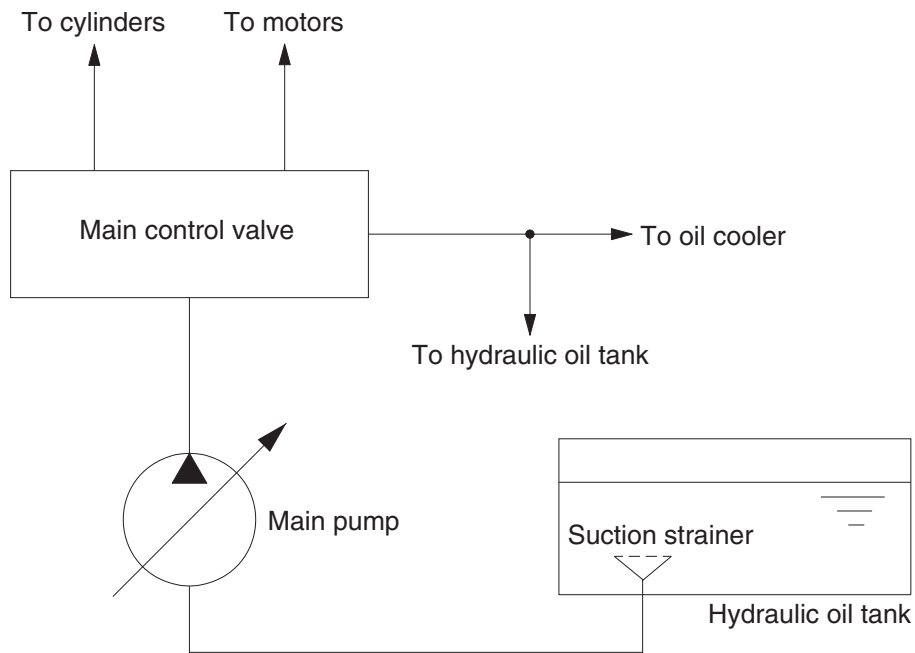

140L3CI01

The pumps receive oil from the hydraulic tank through a suction strainer. The discharged oil from the pump flows into the control valve and goes out the tank ports.

The oil discharged from the main pump flows to the actuators through the main control valve.

The main control valve controls the hydraulic functions.

The return oil from the actuators flows to the hydraulic tank through the main control valve and the oil cooler.

## 2. RETURN CIRCUIT

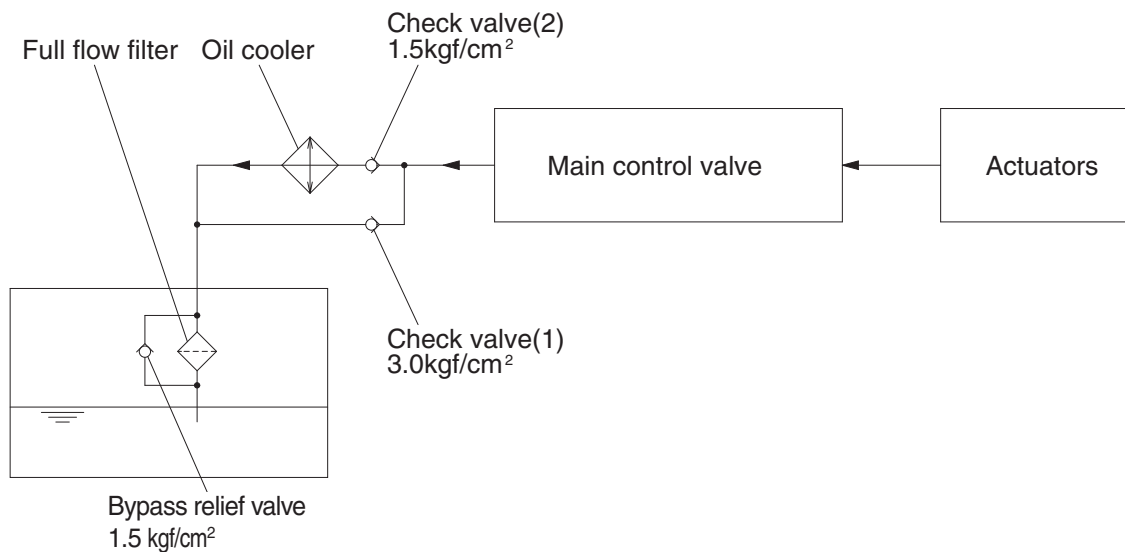

21073CI01

All oil returned from each actuator returns to the hydraulic tank through the main control valve.

The bypass check valves are provided in the return circuit.

The setting pressure of bypass check valves are  $1.5 \text{ kgf/cm}^2$  (21 psi) and  $3.0 \text{ kgf/cm}^2$  (43 psi). Usually, oil returns to the hydraulic tank from the left side of control valve through oil cooler.

When oil temperature is low, viscosity becomes higher and flow resistance increases when passing through the oil cooler. When the oil pressure exceeds  $3.0 \text{ kgf/cm}^2$  (43 psi), the oil returns directly to the hydraulic tank, resulting in the oil temperature being raised quickly at an appropriate level.

When the oil cooler is clogged, the oil returns directly to the hydraulic tank through bypass check valve (1).

The full-flow filter and bypass relief valve are provided in the hydraulic tank.

The oil returned from right and left side of control valve is combined and filtered by the full-flow filter. A bypass relief valve is provided in the full-flow filter.

When the filter element is clogged, the bypass relief valve opens at  $1.5 \text{ kgf/cm}^2$  (21 psi) differential pressure.

### 3. DRAIN CIRCUIT

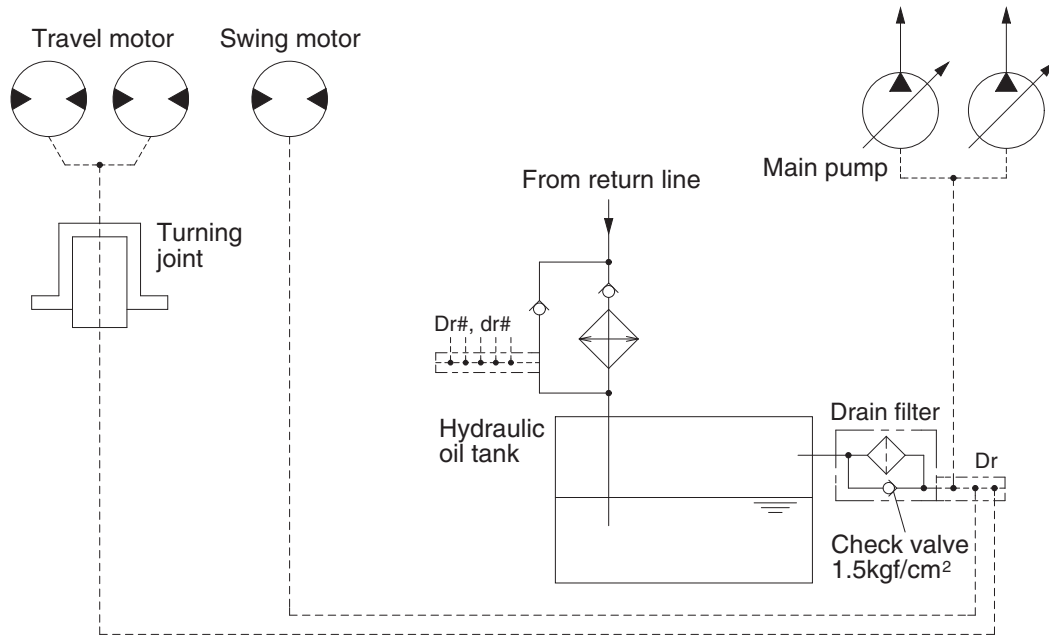

21093CI02

Besides internal leaks from the motors and main pump, the oil for lubrication circulates. These oil have to be fed to the hydraulic tank passing through drain filter.

When the drain oil pressure exceed 1.5 kgf/cm<sup>2</sup> (21 psi), the oil returns to the hydraulic tank directly.

#### 1) TRAVEL MOTOR DRAIN CIRCUIT

Oil leaked from the right and left travel motors comes out of the drain ports provided in the respective motor casing and join with each other. These oils pass through the turning joint and return to the hydraulic tank after being filtered by drain filter.

#### 2) SWING MOTOR DRAIN CIRCUIT

Oil leaked from the swing motor returns to the hydraulic tank passing through a drain filter.

#### 3) MAIN PUMP DRAIN CIRCUIT

Oil leaked from main pump returns to the hydraulic tank passing through drain filter.

## GROUP 3 PILOT CIRCUIT

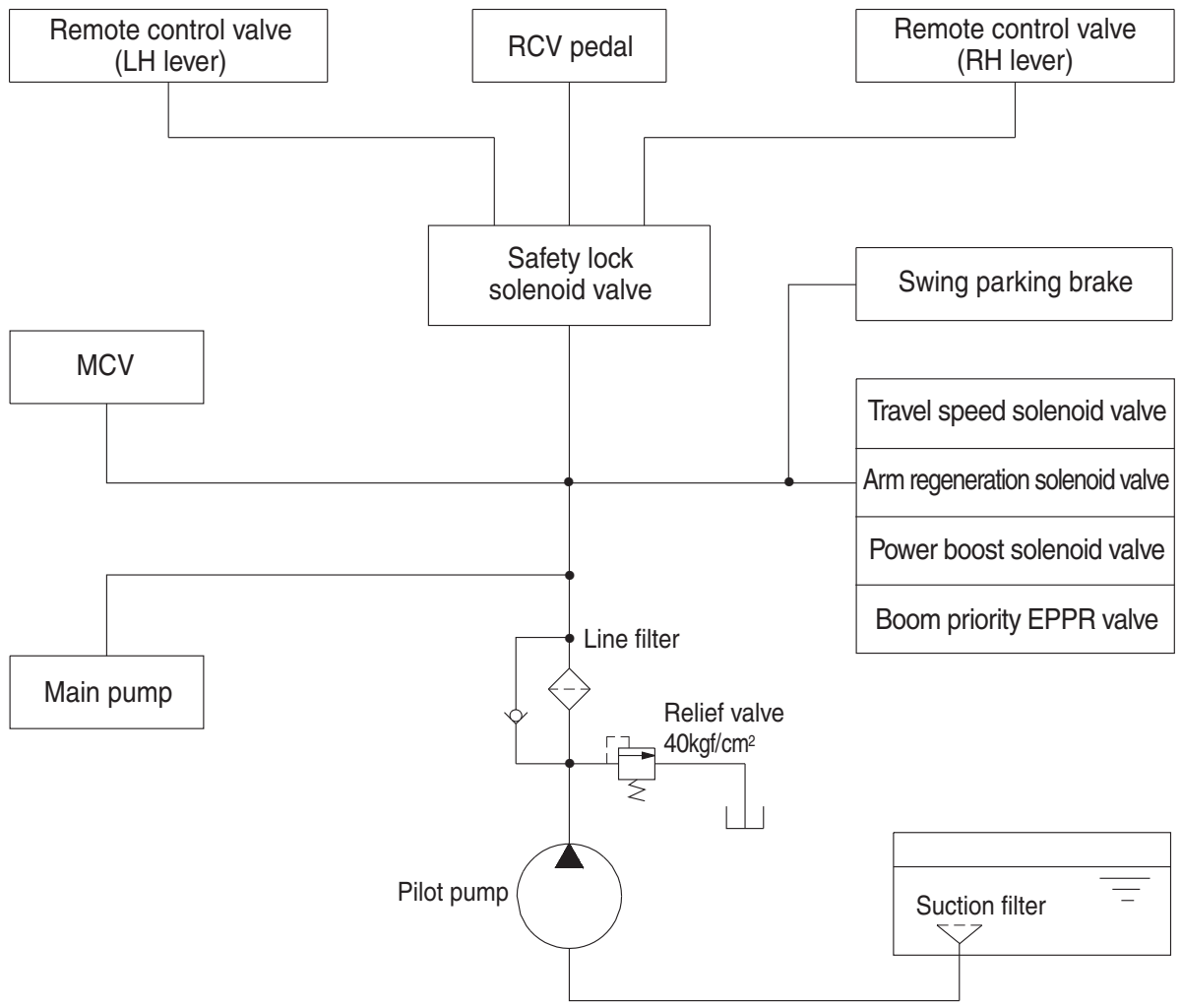

(210-7) 3-05

The pilot circuit consists of suction circuit, delivery circuit and return circuit. The pilot pump is provided with relief valve, receives the oil from the hydraulic tank through the suction filter. The discharged oil from the pilot pump flows to the remote control valve through line filter, EPPR valve, solenoid valve assemblies, swing parking brake, main control valve and safety lock solenoid valve.

# 1. SUCTION, DELIVERY AND RETURN CIRCUIT

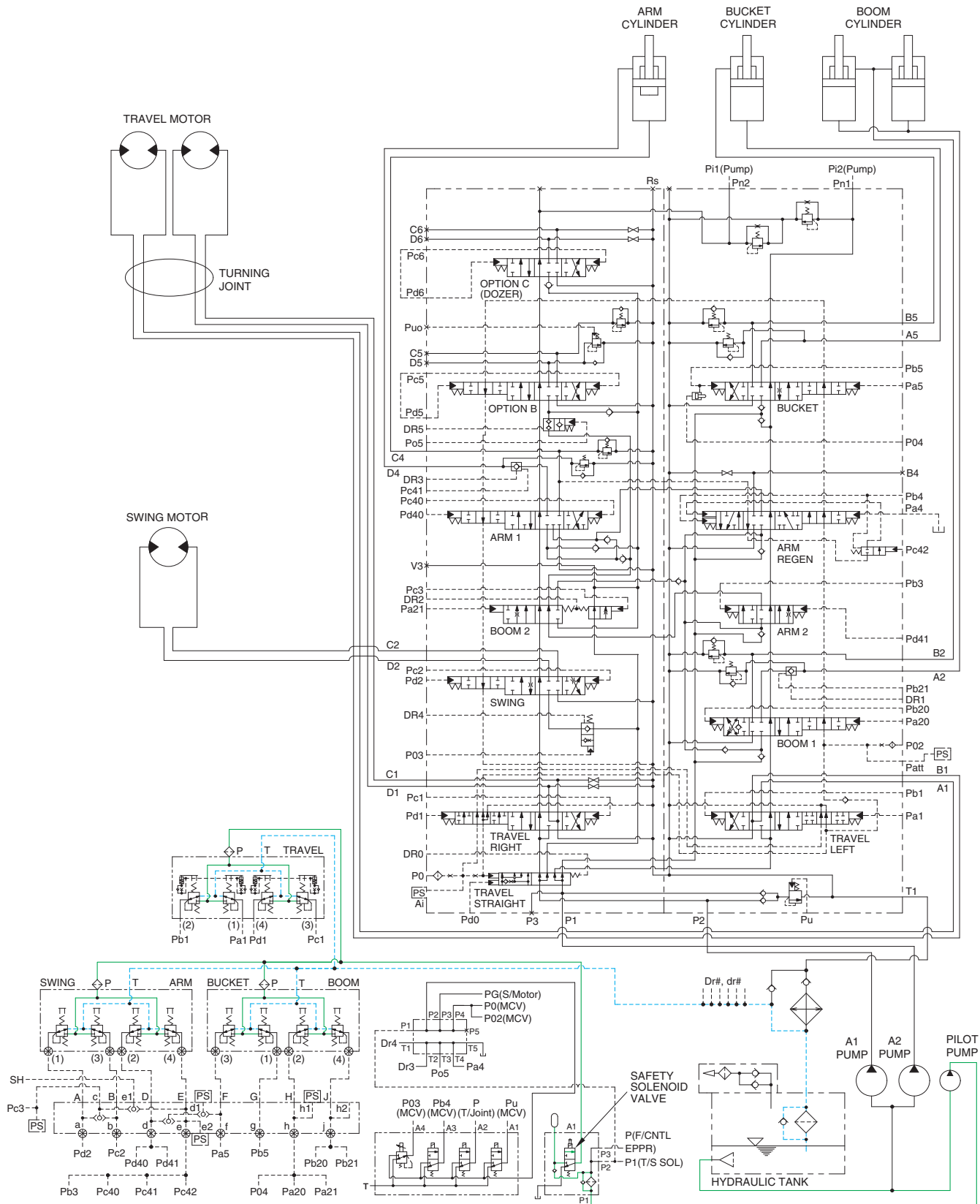

145ZF3HC02

The pilot pump receive oil from the hydraulic tank. The discharged oil from the pilot pump flows to the safety solenoid valve. The oil is filtered by the line filter.  
 The pilot relief valve is provided in the pilot pump for limiting the pilot circuit pressure.  
 The oil filtered by line filter flows remote control valve through safety solenoid valve.  
 The return oil flow into the hydraulic tank.

## 2. SAFETY VALVE (SAFETY LEVER)

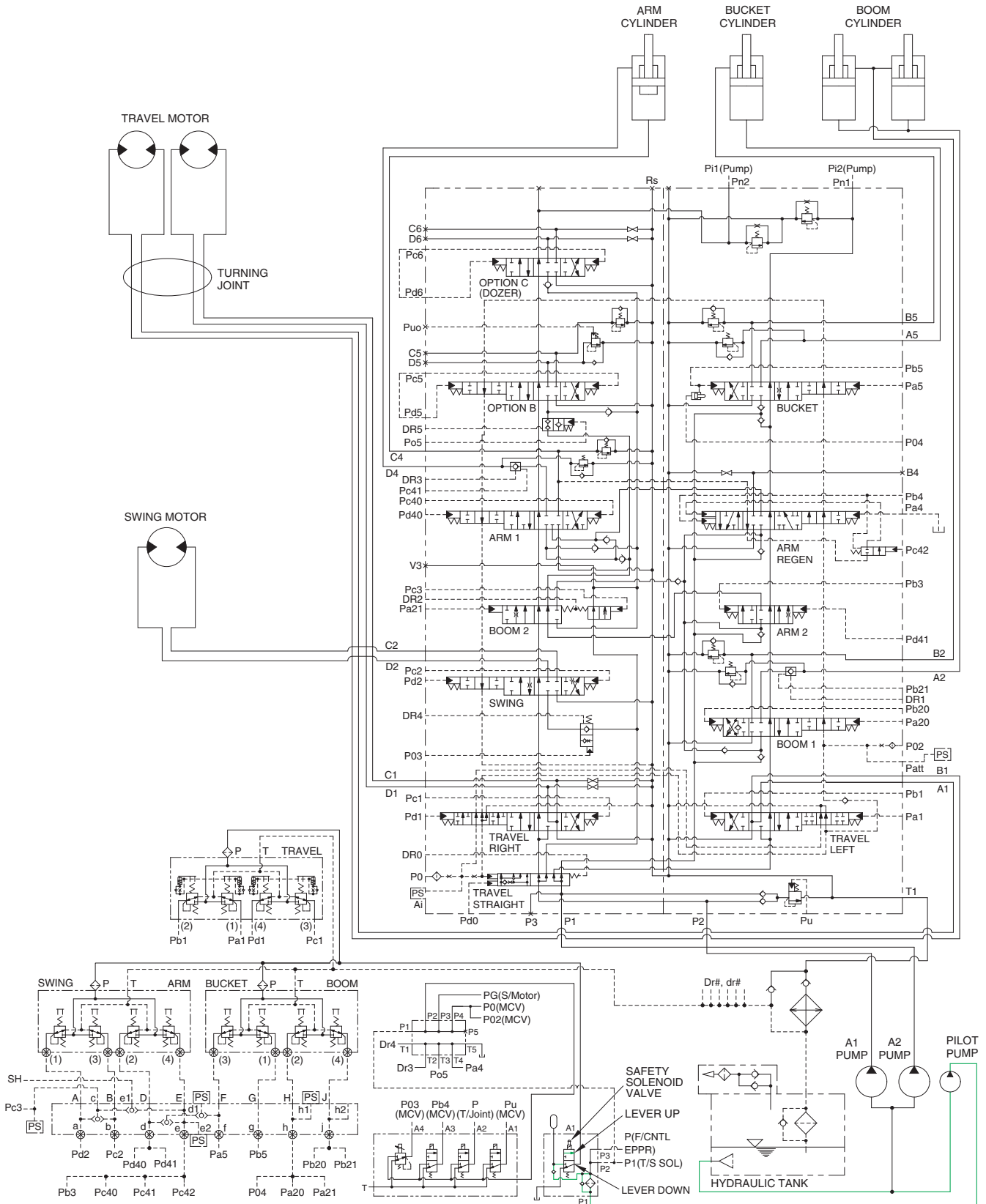

145ZF3HC03

When the lever of the safety solenoid valve is moved upward, oil flows into the remote control valve through solenoid valve and line filter.

When the lever of the safety solenoid valve is moved downward, oil does not flow into the remote control valve, because of the blocked port.



### 3. BOOM PRIORITY SYSTEM

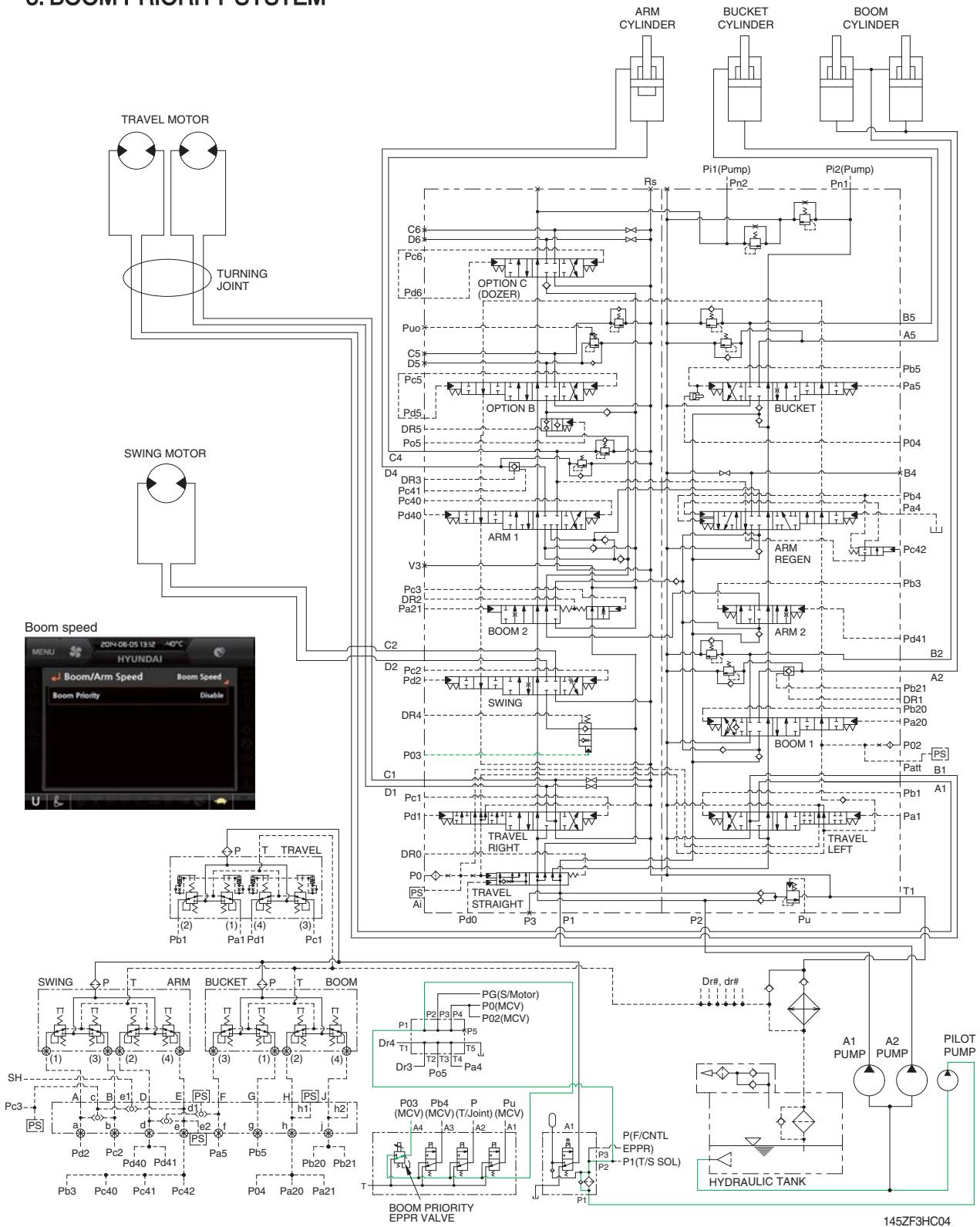

When carrying out the combined operation of swing and boom up, the boom up operating speed is lowered then normal operation.

To increase working efficiency, swing speed reducing system is used.

The pilot oil from pilot pump flow into **P03** port in main control valve through boom priority EPPR valve. **P03** oil pressure moves swing reducing spool to lower position and oil flow rate to the swing motor decreased.

Then, the boom up speed is increased. This is called the boom priority system.

The boom up speed can be adjusted by the cluster. Refer to page 3-20 of the operator's manual.

# 4. TRAVEL SPEED CONTROL SYSTEM

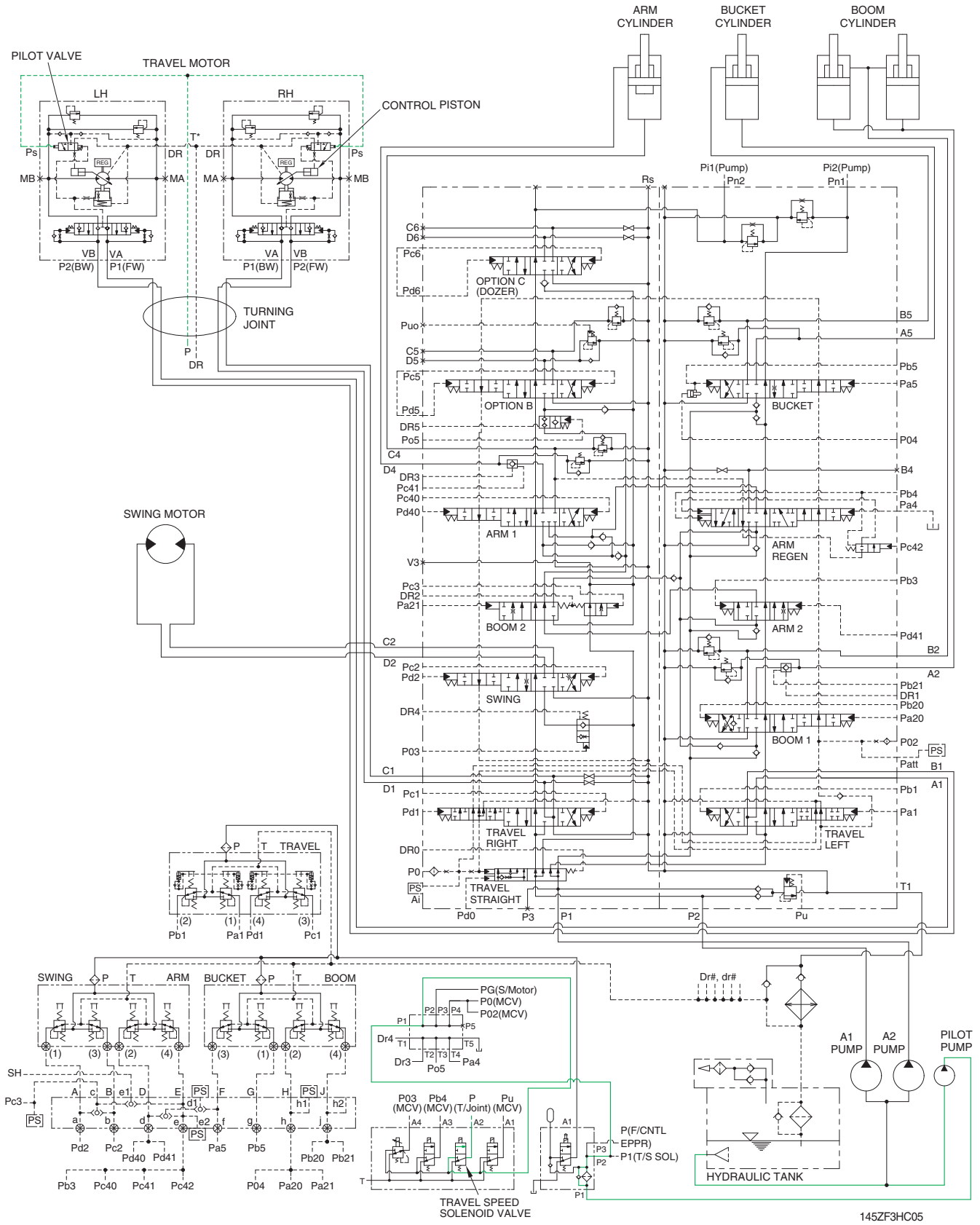

When the travel speed solenoid valve was placed in the Hi position, the pressure oil from pilot pump through line filter flows to port **Ps** of travel speed change over valve, and the control piston is pushed up, thus minimizing the displacement.

When the travel speed solenoid valve was placed in the Lo position, the oil of **Ps** port return to the tank and the control piston is returned, thus maximizing the displacement.

## 5. MAIN RELIEF PRESSURE CHANGE SYSTEM

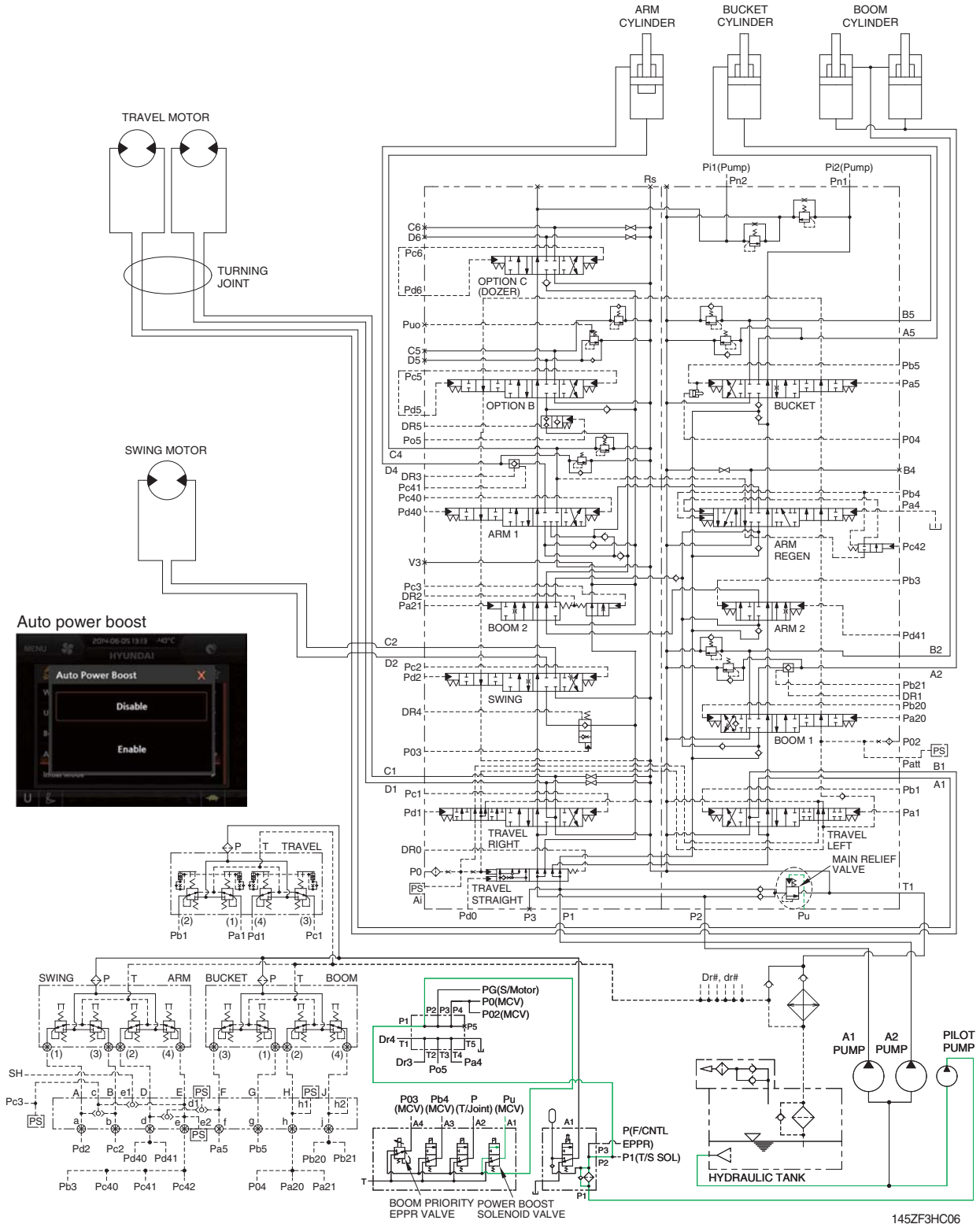

Auto power boost



When the power boost switch on the left control lever is pushed ON, the power boost solenoid valve is actuated, the discharged oil from the pilot pump flows into **Pu** port of the main relief valve of main control valve; then the setting pressure of the main relief valve is raised from 350 kgf/cm<sup>2</sup> (4980 psi) to 380 kgf/cm<sup>2</sup> (5400 psi) for increasing the digging power.

And even when pressed continuously, it is canceled after 8 seconds.

When the auto power boost function is selected to enable on the cluster, the pressure of the main relief pressure is automatically increased to 380 kgf/cm<sup>2</sup> (5400 psi) as working condition by the MCU. It is operated max 8 seconds.

## 6. ARM REGENERATION CUT SYSTEM

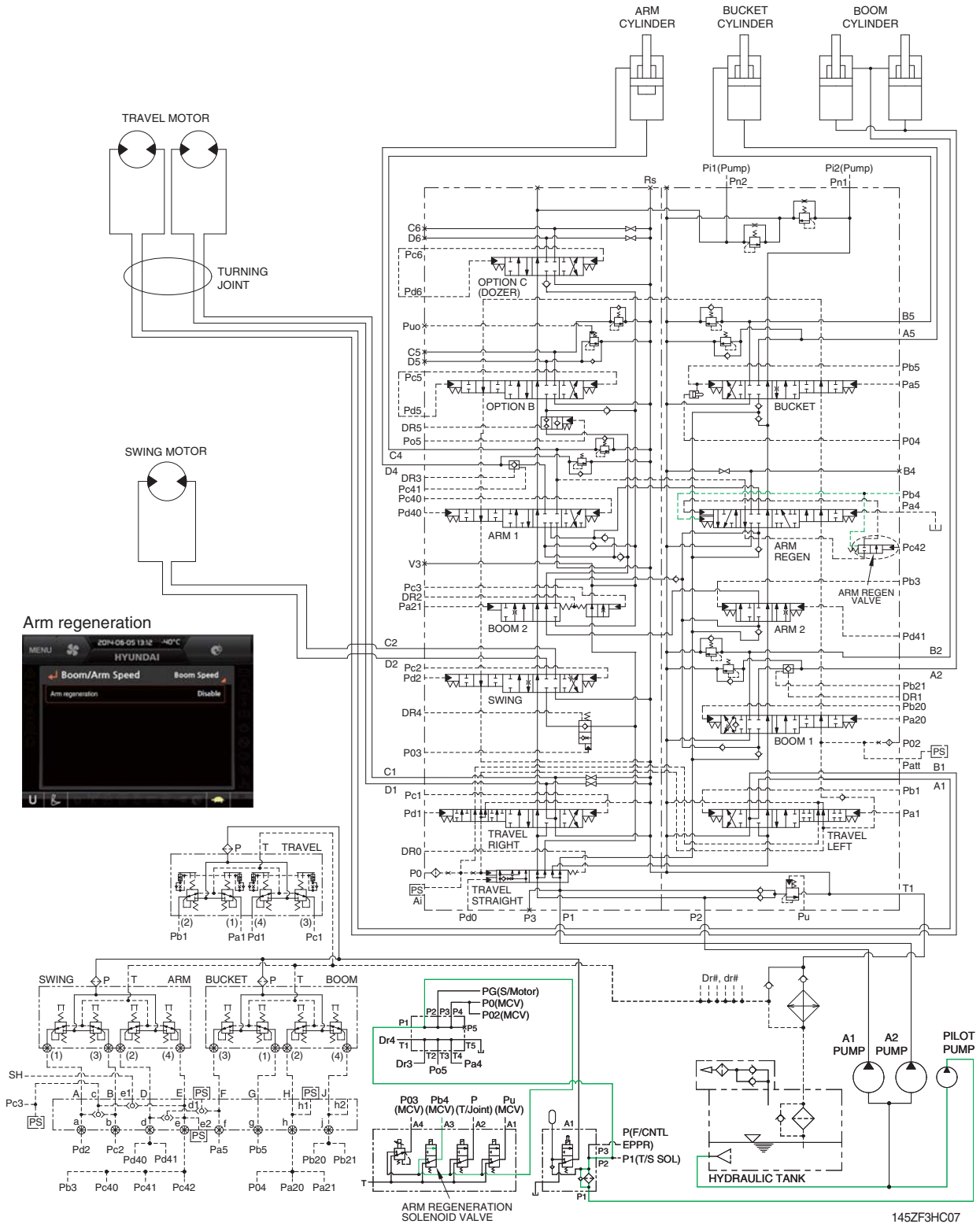

When the arm regeneration is selected to disable on the cluster, the arm regeneration solenoid valve is activated. The pilot oil from pilot pump flow into **Pb4** port in main control valve through solenoid valve and the arm regeneration spool is shifted to left.

Then, the oil from arm regeneration passage returns to tank and the arm regeneration function is deactivated.

When the arm regeneration is selected to enable on the cluster, the arm regeneration function is activated and arm in operation speed is increased.

Refer to page 2-36 for the arm regeneration function.

## 7. SWING PARKING BRAKE RELEASE

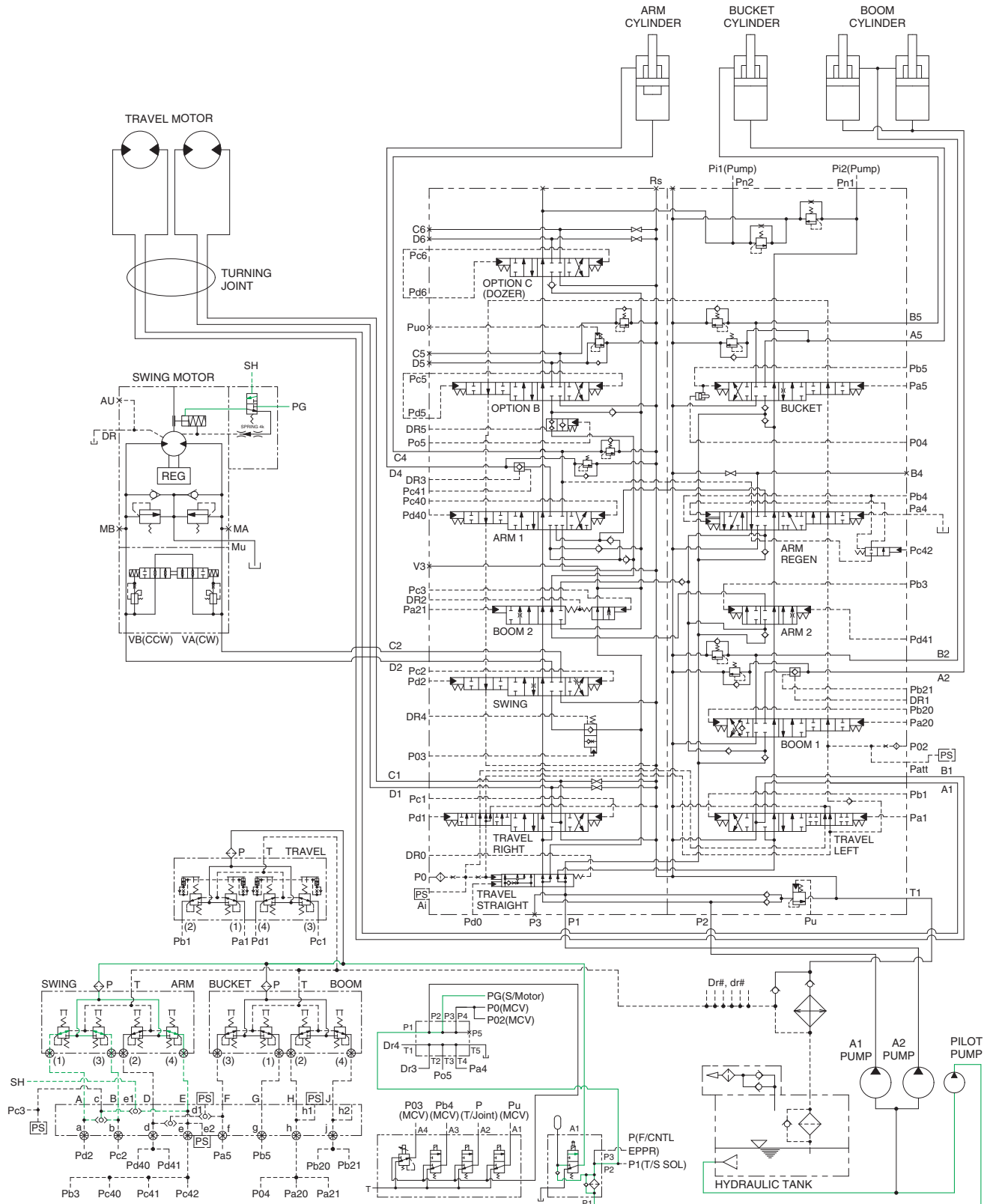

145ZF3HC08

When the swing control lever or arm in control lever is tilted, the pilot oil flows into SH port through shuttle valve.

This pressure moves spool of the swing brake valve so, discharged oil from pilot valve flows to swing motor PG port. This pressure is applied to swing motor disc, thus the brake is released.

When the swing control lever and arm in control lever are set in the neutral position, oil in the swing motor disc cylinder is drained, thus the brake is applied.

# 8. SWING PRIORITY SYSTEM

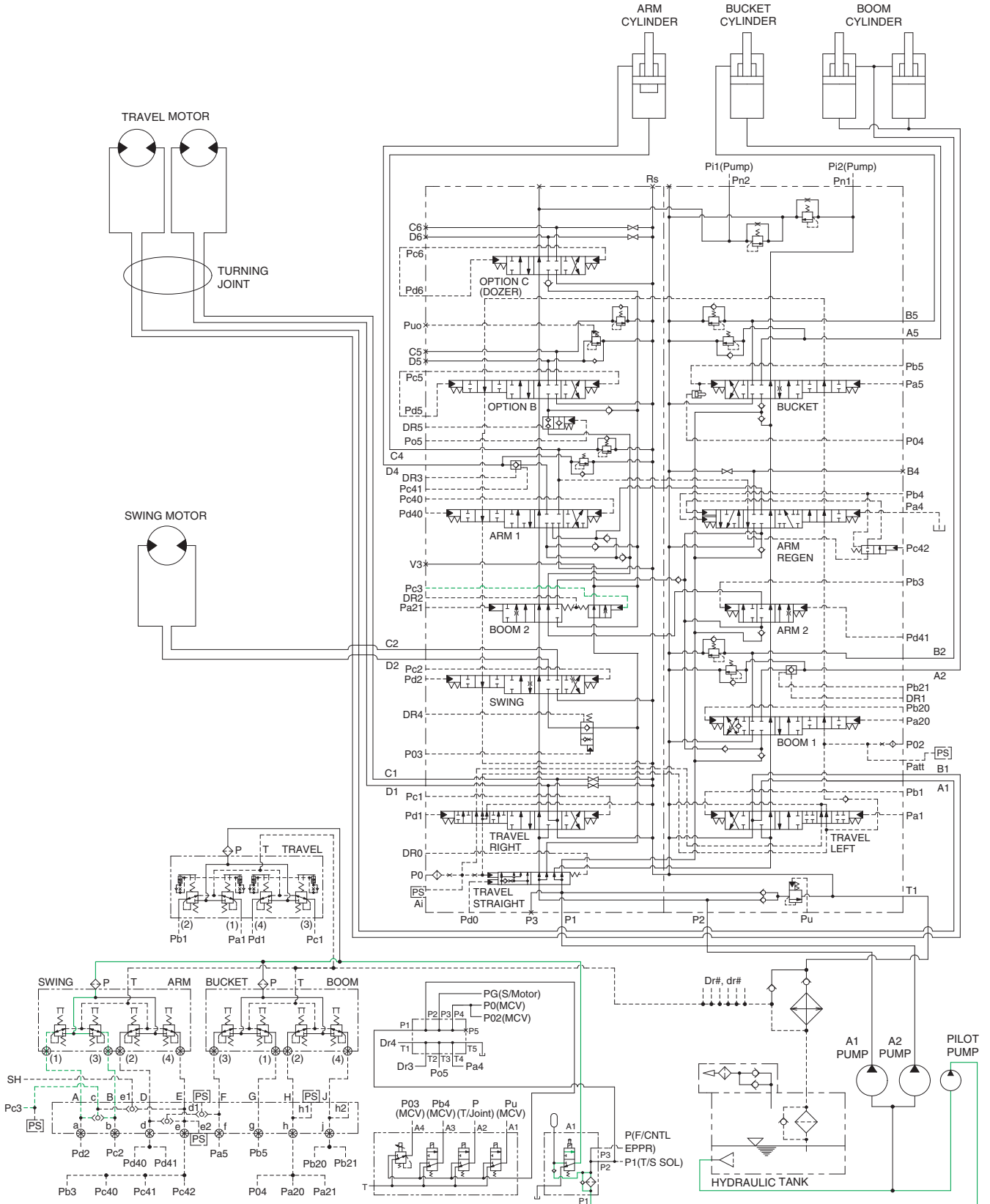

145ZF3HC09

When carrying out the combined operation of swing and arm of the left control valve, the swing speed can be lowered than operating speed of arm. Pc3 pressure from the swing shuttle block change the swing priority spool and decreases the oil flow rate to the next section to make the swing operation most preferential. This is called the swing priority system. For details, refer to page 2-39.

## 9. BOOM FLOATING SYSTEM

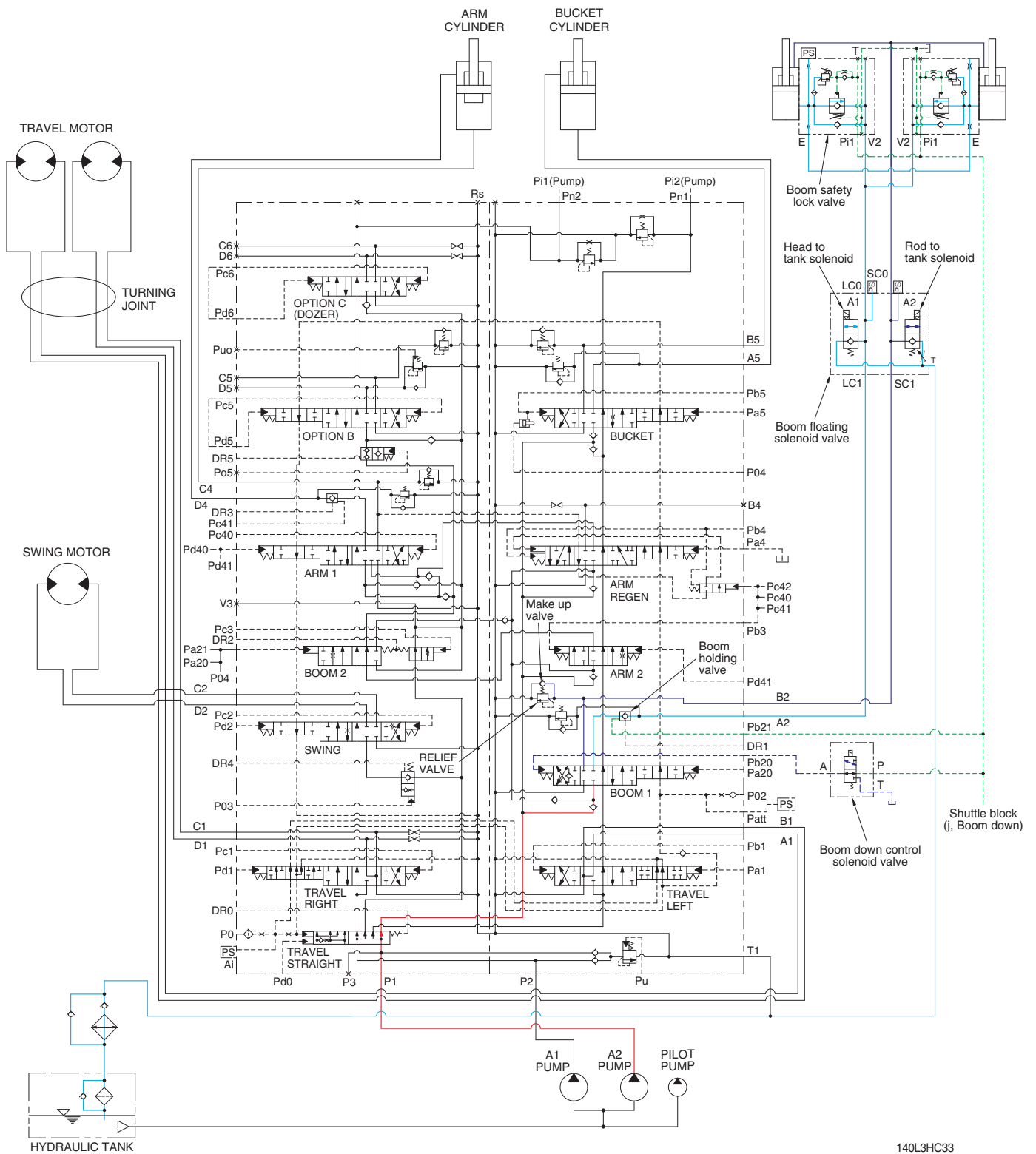

140L3HC33

Smooth and convenient boom movement is accomplished by only arm control lever operation.

The boom floating solenoid valves are equipped in the rod and head of boom cylinder that are controlled to act as floating mode.

"Rod to tank solenoid" and "Head to tank solenoid" are active. So the hydraulic oil of rod and head goes to tank, and floating is accomplished. In the mode, boom down control solenoid is active so that boom down pilot pressure is cut.

For more details, refer to page 5-13.

# GROUP 4 SINGLE OPERATION

## 1. BOOM UP OPERATION

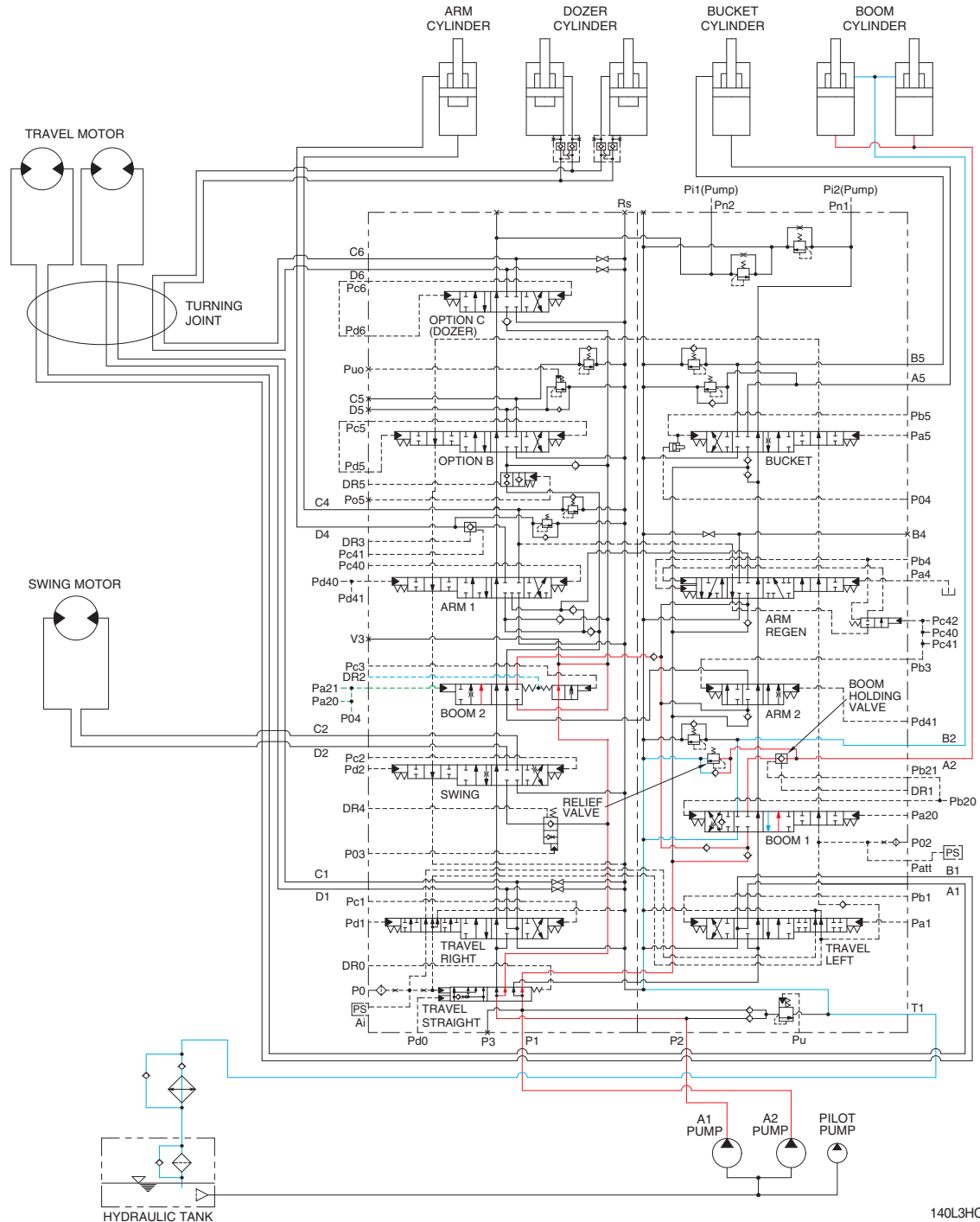

140L3HC10

When the right control lever is pulled back, the boom spools in the main control valve are moved to the up position by the pilot oil pressure from the remote control valve.

The oil from the A1 and A2 pump flows into the main control valve and then goes to the large chamber of boom cylinders. At the same time, the oil from the small chamber of boom cylinders returns to the hydraulic oil tank through the boom 1 spool in the main control valve. When this happens, the boom goes up. The excessive pressure in the boom cylinder head side is prevented by relief valve. When the boom is up and the control lever is returned to neutral position, the circuit for the holding pressure at the head side of the boom cylinder is closed by the boom holding valve. This prevents the hydraulic drift of boom cylinder.



## 2. BOOM DOWN OPERATION

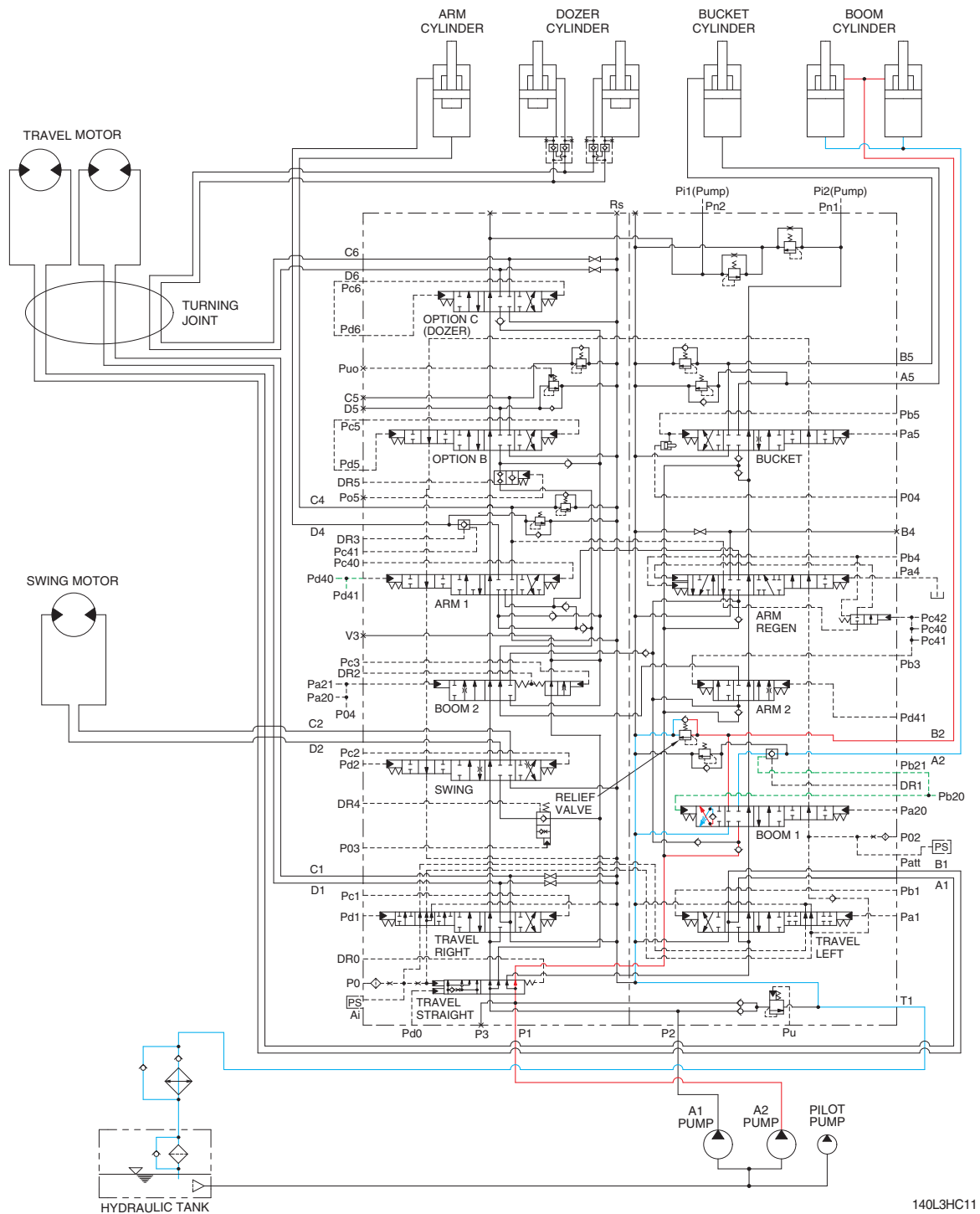

When the right control lever is pushed forward, the boom 1 spool in the main control valve is moved to the down position by the pilot oil pressure from the remote control valve.

The oil from the A2 pump flows into the main control valve and then goes to the small chamber of boom cylinders. At the same time, the oil from the large chamber of boom cylinders returns to the hydraulic tank through the boom 1 spool in the main control valve.

When the down speed of boom is faster, the oil returned from the large chamber of boom cylinder combines with the oil from the A2 pump, and flows into the small chamber of the cylinder.

This prevents cylinder cavitation by the negative pressure when the A2 pump flow can not match the boom down speed. And the excessive pressure in the boom cylinder rod side is prevented by the relief valve.

### 3. ARM IN OPERATION

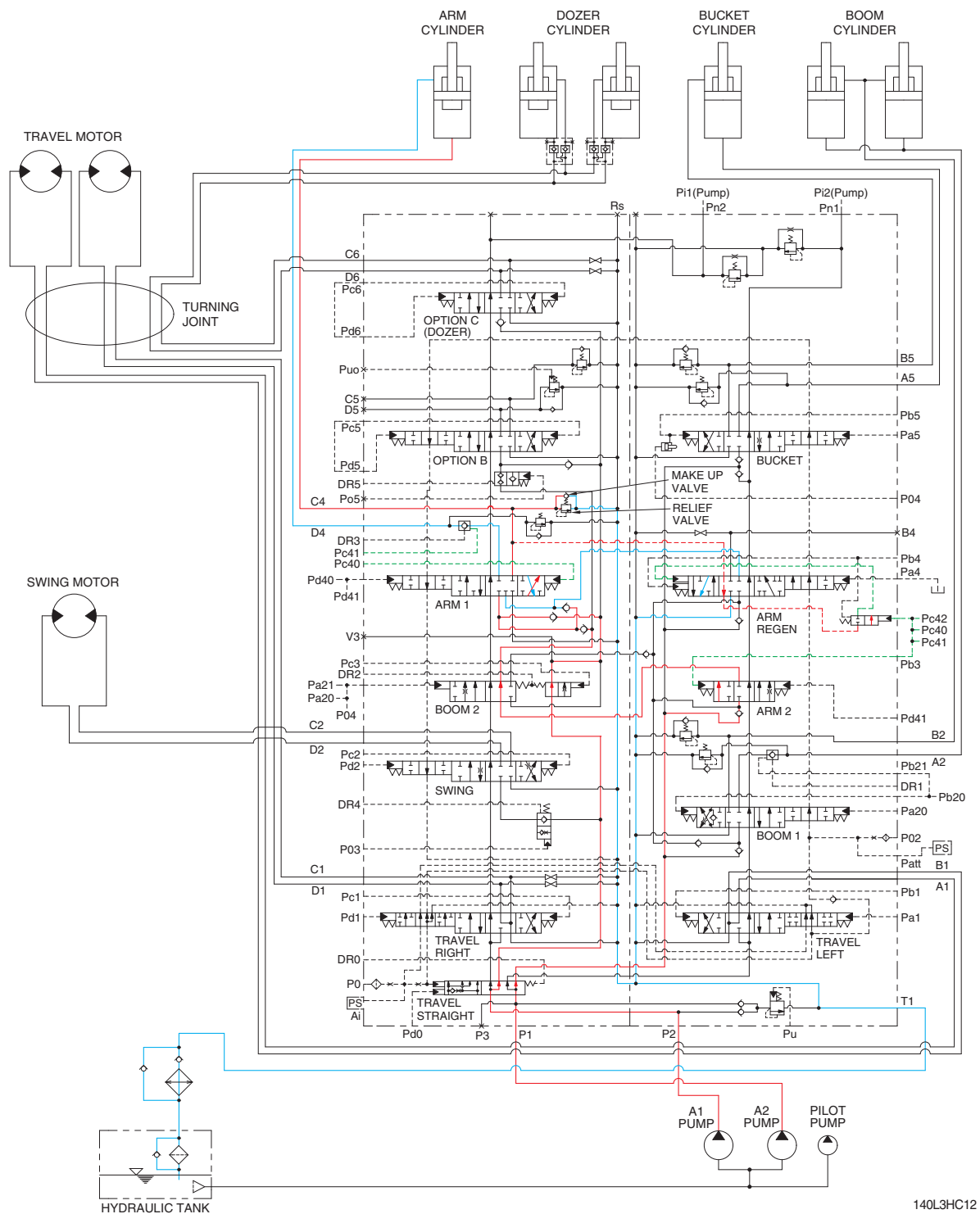

140L3HC12

When the left control lever is pulled back, the arm spools in the main control valve are moved to the arm in position by the pilot oil pressure from the remote control valve.

The oil from the A1 and A2 pump flows into the main control valve and then goes to the large chamber of arm cylinder.

At the same time, the oil from small chamber of arm cylinder returns to the hydraulic oil tank through the arm 1 spool in the main control valve. When this happens, the arm rolls in.

The excessive pressure in the arm cylinder head side is prevented by relief valve.

The cavitation which will happen to the head side of the arm cylinder is also prevented by the make-up valve in the main control valve.

## 4. ARM OUT OPERATION

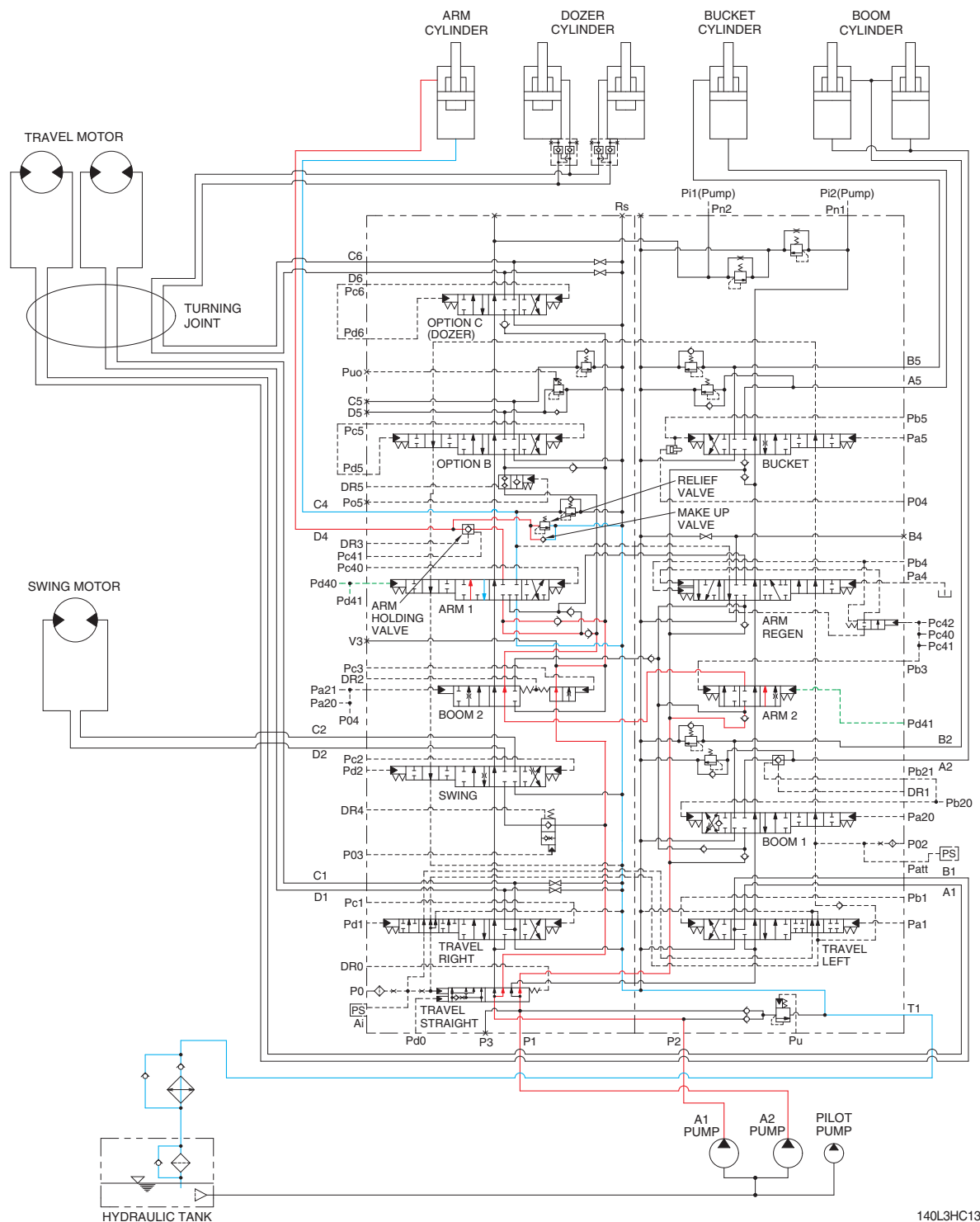

140L3HC13

When the left control lever is pushed forward, the arm spools in the main control valve are moved to the arm out position by the pilot oil pressure from the remote control valve.

The oil from the A1 and A2 pump flows into the main control valve and then goes to the small chamber of arm cylinder. At the same time, the oil from the large chamber of arm cylinder returns to the hydraulic oil tank through the arm 1 spool in the main control valve. When this happens, the arm rolls out. The cavitation which will happen to the rod side of the arm cylinder is also prevented by the make-up valve in the main control valve. When the arm is roll out and the control lever is returned to neutral position, the circuit for the holding pressure at the rod side of the arm cylinder is closed by the arm holding valve. This prevent the hydraulic drift of arm cylinder.

## 5. BUCKET IN OPERATION

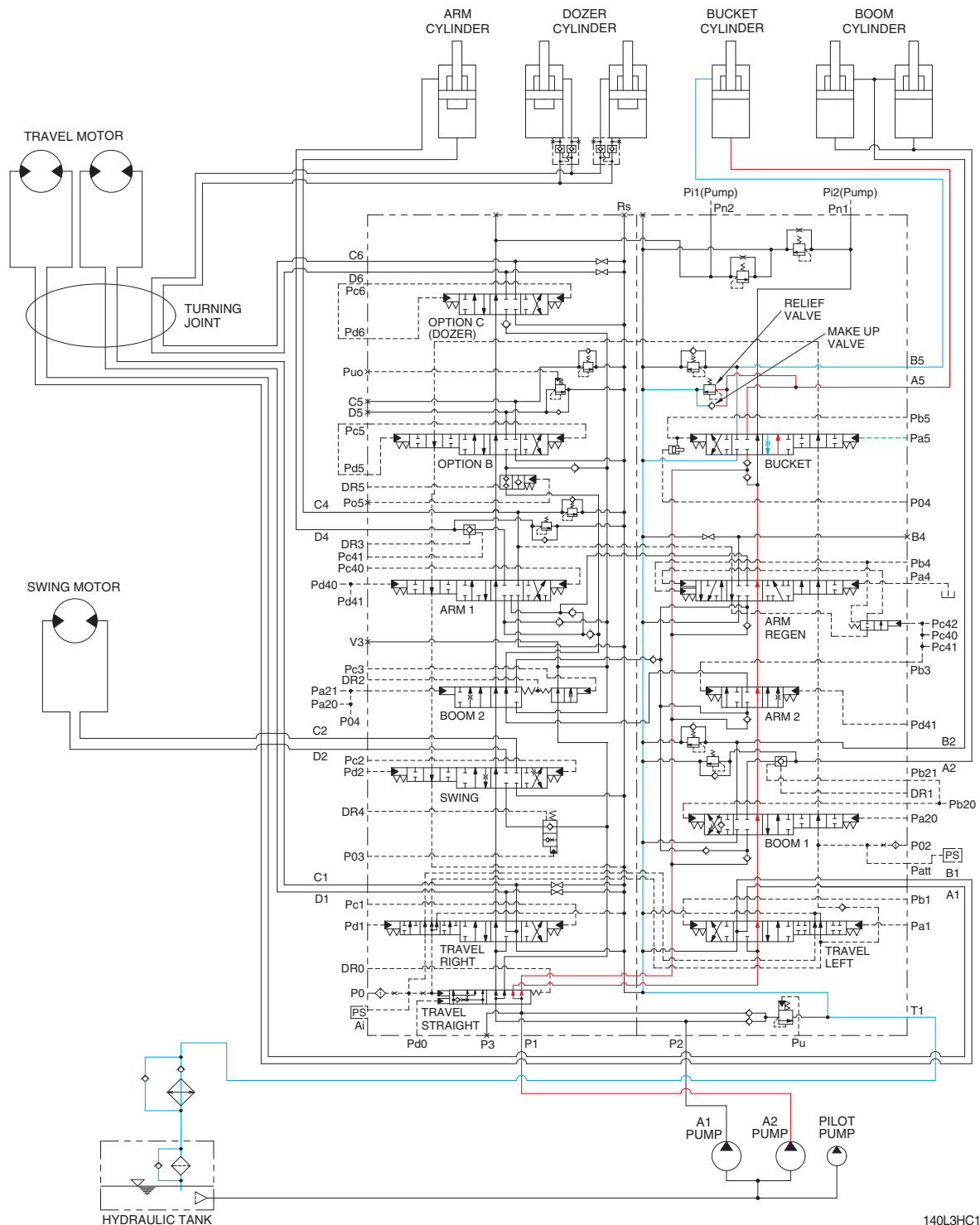

When the right control lever is pulled left, the bucket spool in the main control valve is moved to the roll in position by the pilot oil pressure from the remote control valve.

The oil from the A2 pump flows into the main control valve and then goes to the large chamber of bucket cylinder.

At the same time, the oil from the P00 of the small chamber of bucket cylinder returns to the hydraulic oil tank through the bucket spool in the main control valve. When this happens, the bucket rolls in.

The excessive pressure in the bucket cylinder head side is prevented by relief valve.

The cavitation which will happen to the head side of the bucket cylinder is also prevented by the make-up valve in the main control valve.

## 6. BUCKET OUT OPERATION

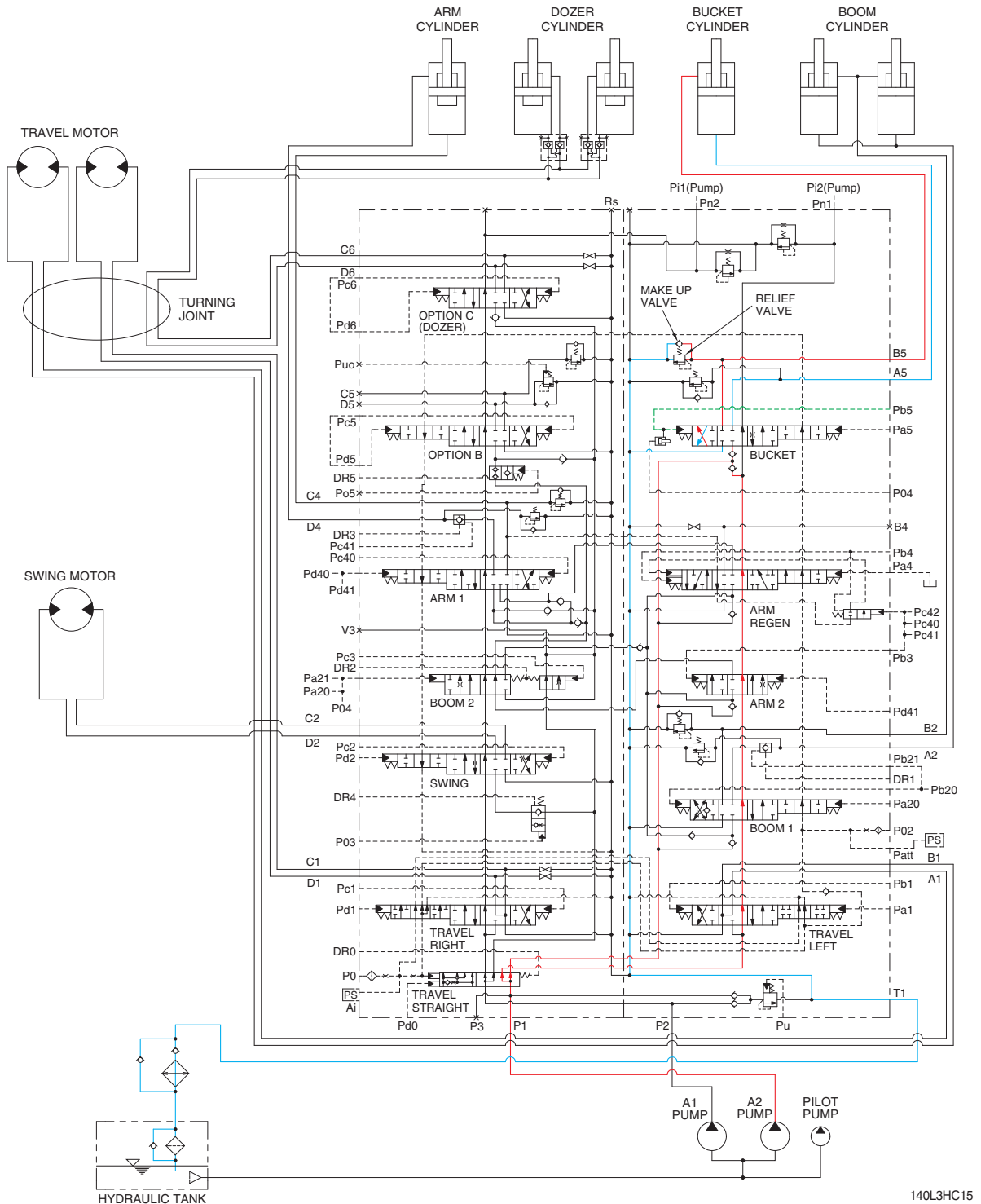

When the right control lever is pushed right, the bucket spool in the main control valve is moved to the bucket out position by the pilot oil pressure from the remote control valve.

The oil from the A2 pump flows into the main control valve and then goes to the small chamber of bucket cylinder.

At the same time, the oil from the large chamber of bucket cylinder returns to the hydraulic oil tank through the bucket spool in the main control valve. When this happens, the bucket rolls out.

The excessive pressure in the bucket cylinder rod side is prevented by relief valve.

The cavitation which will happen to the rod side of the bucket cylinder is also prevented by the make-up valve in the main control valve.

## 7. DOZER UP OPERATION

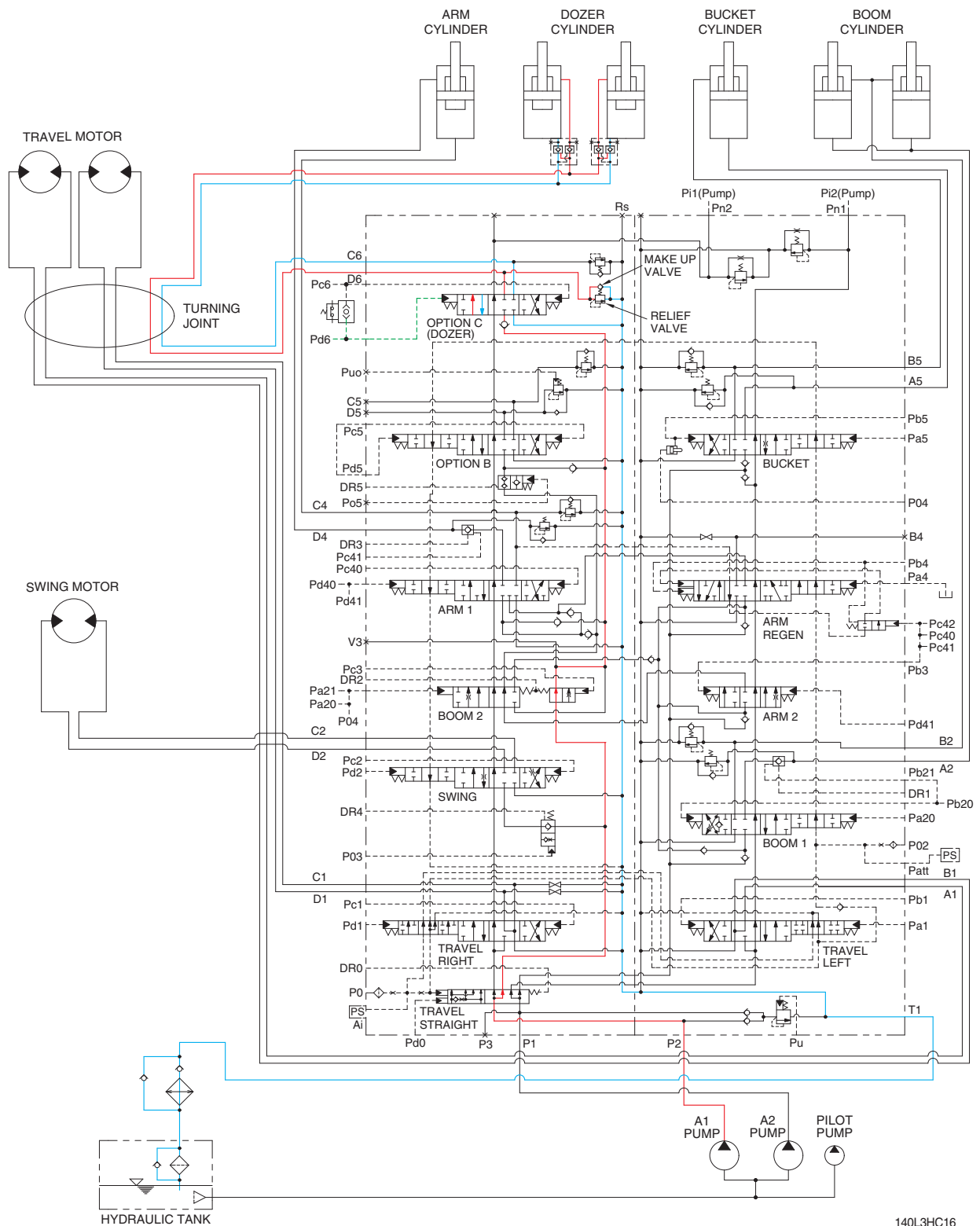

When the dozer control lever is pulled back, the dozer spool in the main control valve is moved to the dozer up position by the pilot oil pressure from the remote control valve.

The oil from the A1 pump flows into the main control valve and then goes to the small chamber of dozer cylinder.

At the same time, the oil from the large chamber of dozer cylinders returns to the hydraulic oil tank through the dozer spool in the main control valve. When this happens, the dozer goes up.

## 8. DOZER DOWN OPERATION

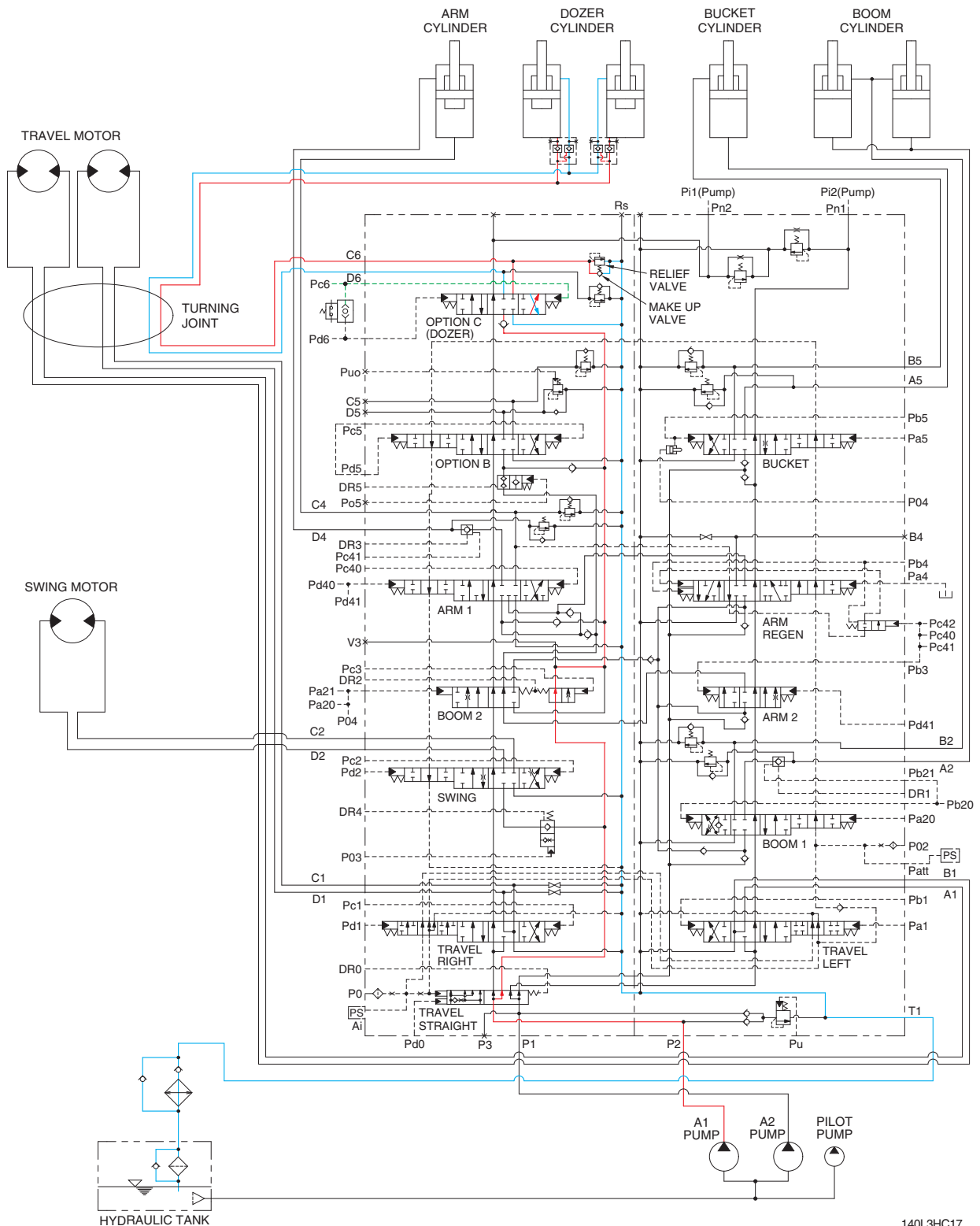

140L3HC17

When the dozer control lever is pushed forward, the dozer spool in the main control valve is moved to the dozer down position by the pilot oil pressure from the remote control valve.

The oil from the A1 pump flows into the main control valve and then goes to the large chamber of dozer cylinder.

At the same time, the oil from the small chamber of dozer cylinders returns to the hydraulic oil tank through the dozer spool in the main control valve. When this happens, the dozer goes down.

## 9. SWING OPERATION

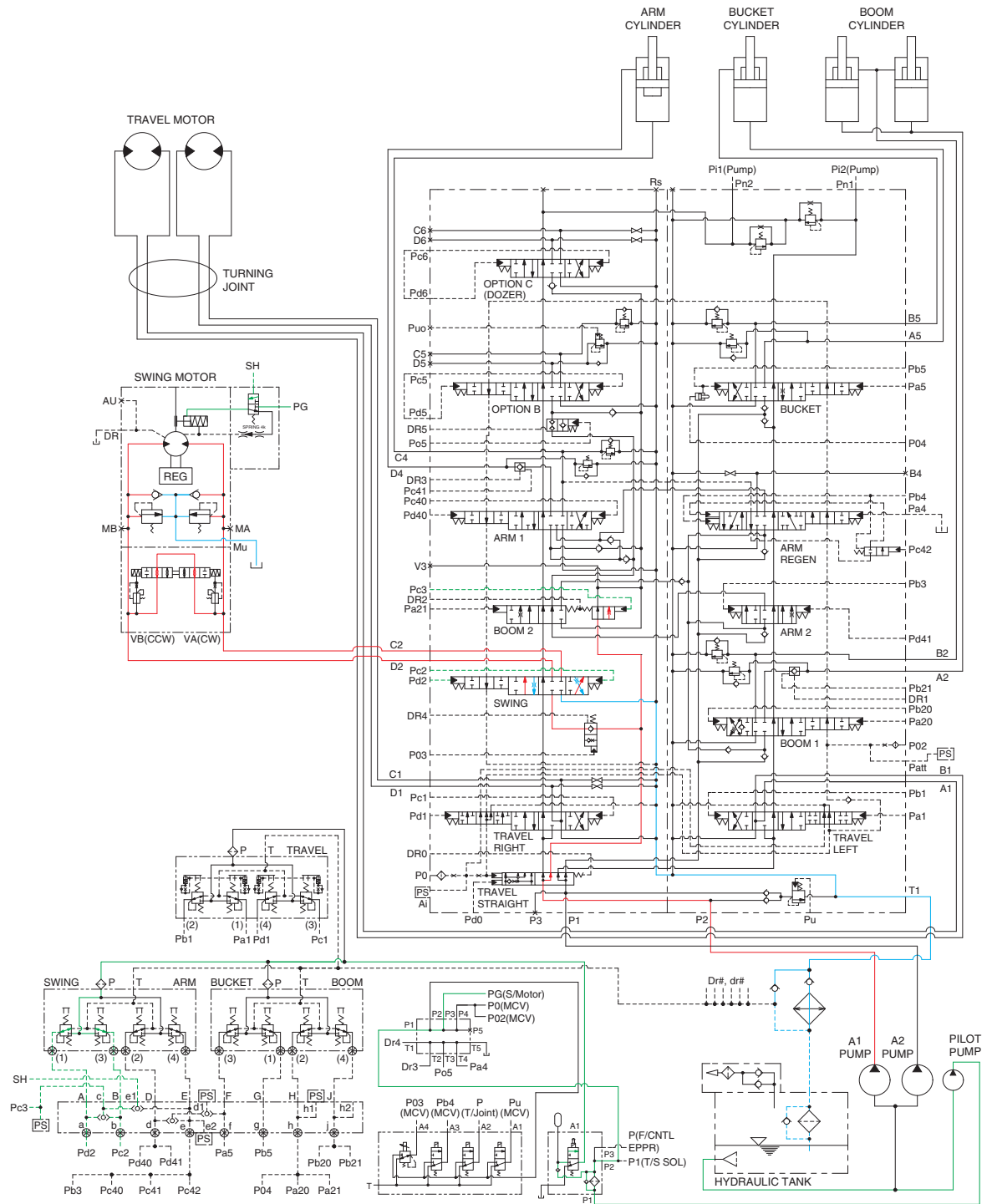

145ZF3HC18

When the left control lever is pushed left or right, the swing spool in the main control valve is moved to the left or right swing position by the pilot oil pressure from the remote control valve.

Also the swing operation preference function is operated by the pilot pressure Pc3 (refer to page 3-13).

The oil from the A1 pump flows into the main control valve and then goes to the swing motor.

At the same time, the return oil from the swing motor returns to the hydraulic oil tank through the swing spool in the main control valve.

When this happens, the upper structure swings to the left or right.

The swing parking brake, make up valve and the P<sub>u</sub> motor brake valve are provided in the swing motor.

The cavitation which will happen to the swing motor is also prevented by the make up valve in the swing motor itself.



## SWING CIRCUIT OPERATION

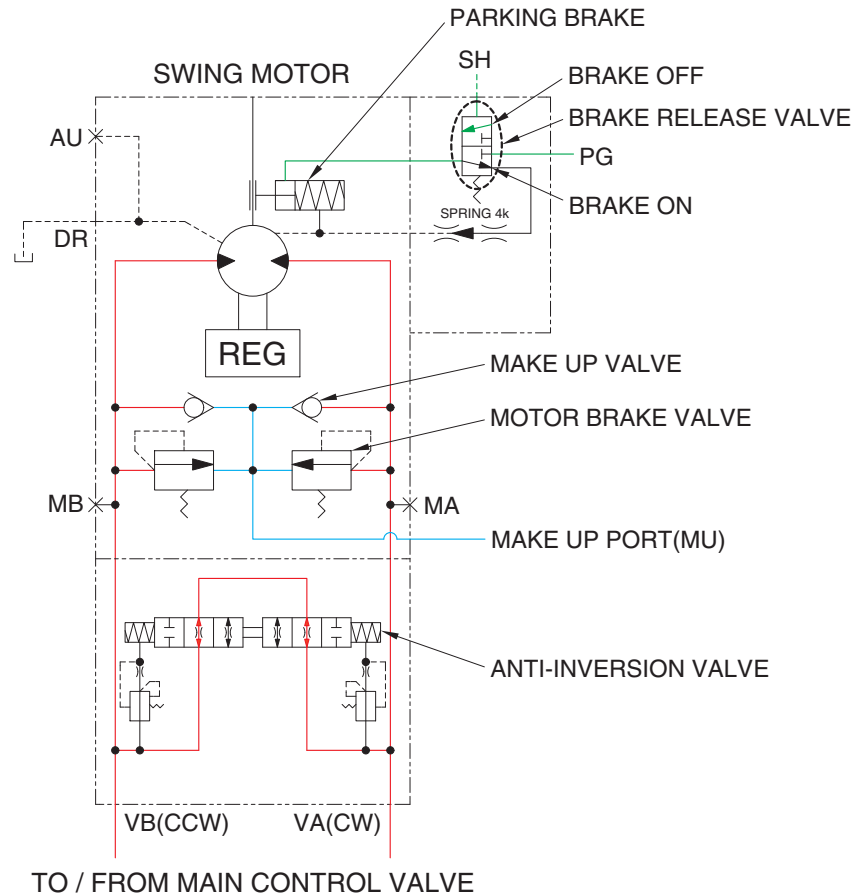

140L3HC18A

### 1) MOTOR BRAKE VALVE

Motor brake valve for the swing motor limits to cushion the starting and stopping pressure of swing operation and controls the swing motor operating pressure.

### 2) MAKE UP VALVE

The make up valves prevent cavitation by supplying return oil to the vacuum side of the motor.

### 3) PARKING BRAKE

This is function as a parking brake only when the swing control lever and arm in control lever are not operated.

#### PARKING BRAKE "OFF" OPERATION

The parking brake is released by the pilot pressure oil from the pilot pump.

When the swing control lever or arm in control lever placed in the operating position, the pilot oil flows into SH port through the MCV. This pressure transferred to the brake release valve and the brake release valve is change over. Then the pilot oil pressure PG lift the brake piston and release the parking brake.

#### PARKING BRAKE "ON" OPERATION

When the swing control lever and arm in control lever placed in the neutral position, the pressure of the pilot oil passage down.

Then the brake release valve returned to the neutral position and the oil is returned from the brake piston to the hydraulic oil tank. And the brake is set to 'ON'.

### 4) ANTI-INVERSION VALVE

This anti-inversion valve absorbs shocks produced as swing motion stops and reduced oscillation cause by swing motion.

## 10. TRAVEL FORWARD AND REVERSE OPERATION

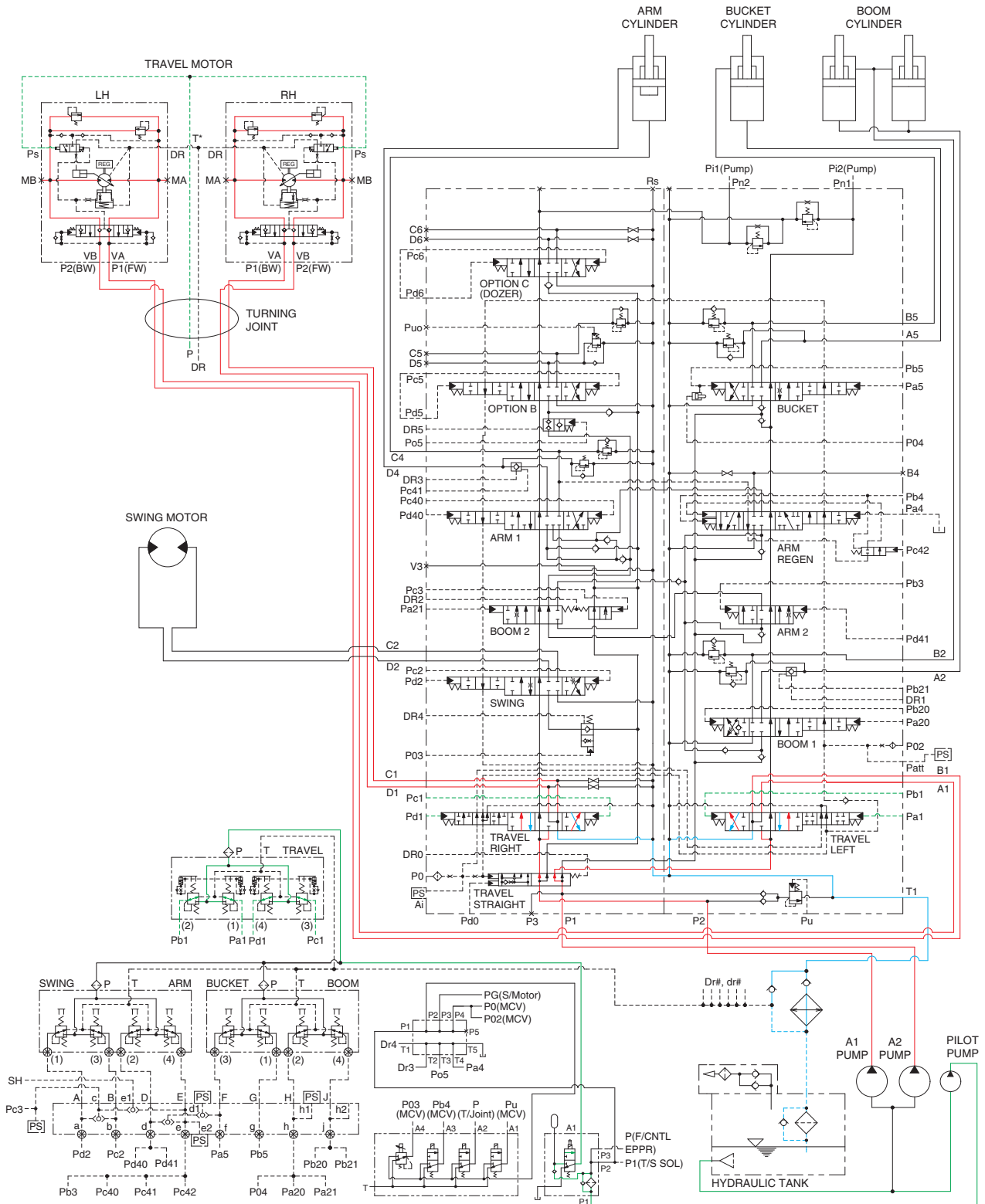

145ZF3HC19

When the travel levers are pushed forward or reverse position, the travel spools in the main control valve are moved to the forward or reverse travel position by the pilot oil pressure from the remote control valve.

The oil from the each pump flows into the main control valve and then goes to the each travel motor through the turning joint.

The return oil from both travel motors returns to the hydraulic oil tank through the turning joint and the travel spools in the main control valve.

When this happens, the machine moves to the forward or reverse.

## TRAVEL CIRCUIT OPERATION

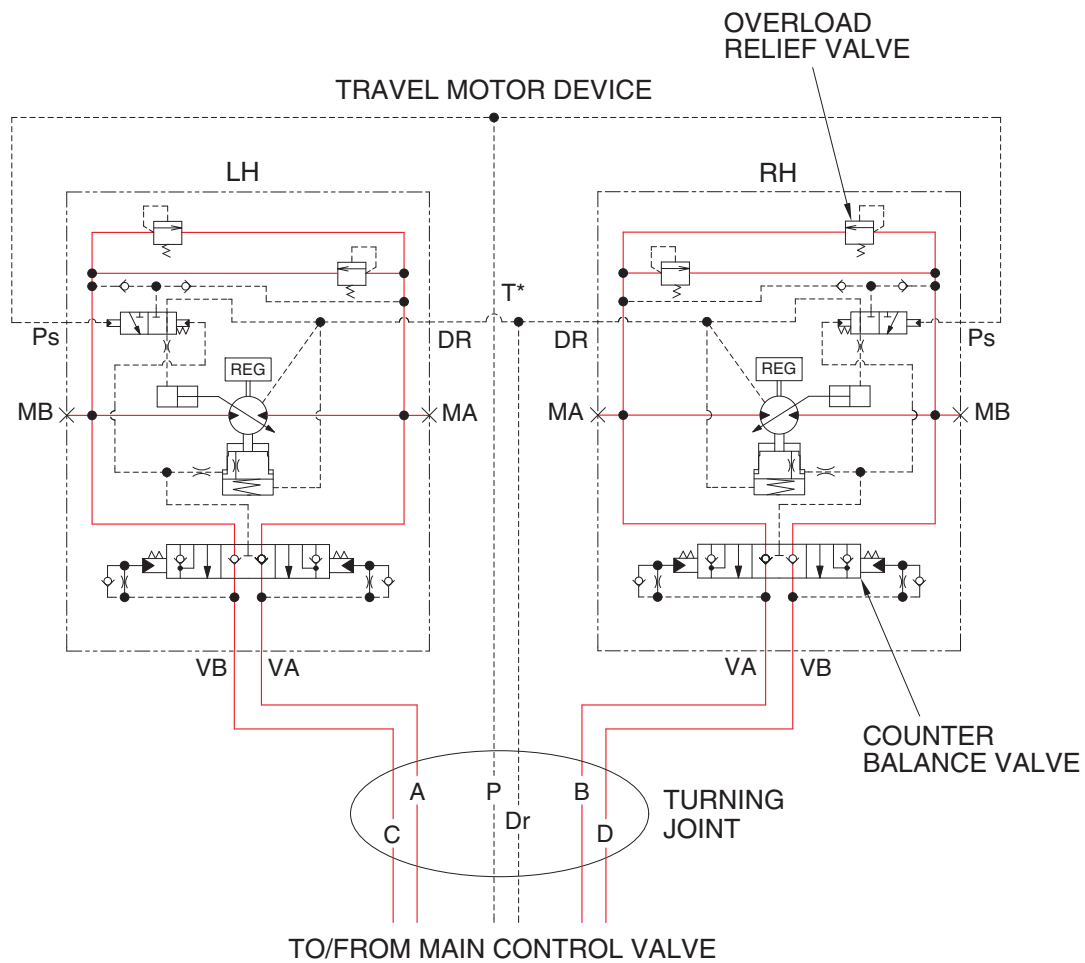

140L3HC19A

Valves are provided on travel motors to offer the following functions.

### 1) COUNTER BALANCE VALVE

When stopping the motor of slope descending, this valve to prevent the motor over run.

### 2) OVERLOAD RELIEF VALVE

Relief valve limit the circuit pressure below 350 kgf/cm<sup>2</sup> (4980 psi) to prevent high pressure generated at a time of stopping the machine. Stopping the motor, this valve sucks the oil from lower pressure passage for preventing the negative pressure and the cavitation of the motor.

# GROUP 5 COMBINED OPERATION

## 1. OUTLINE

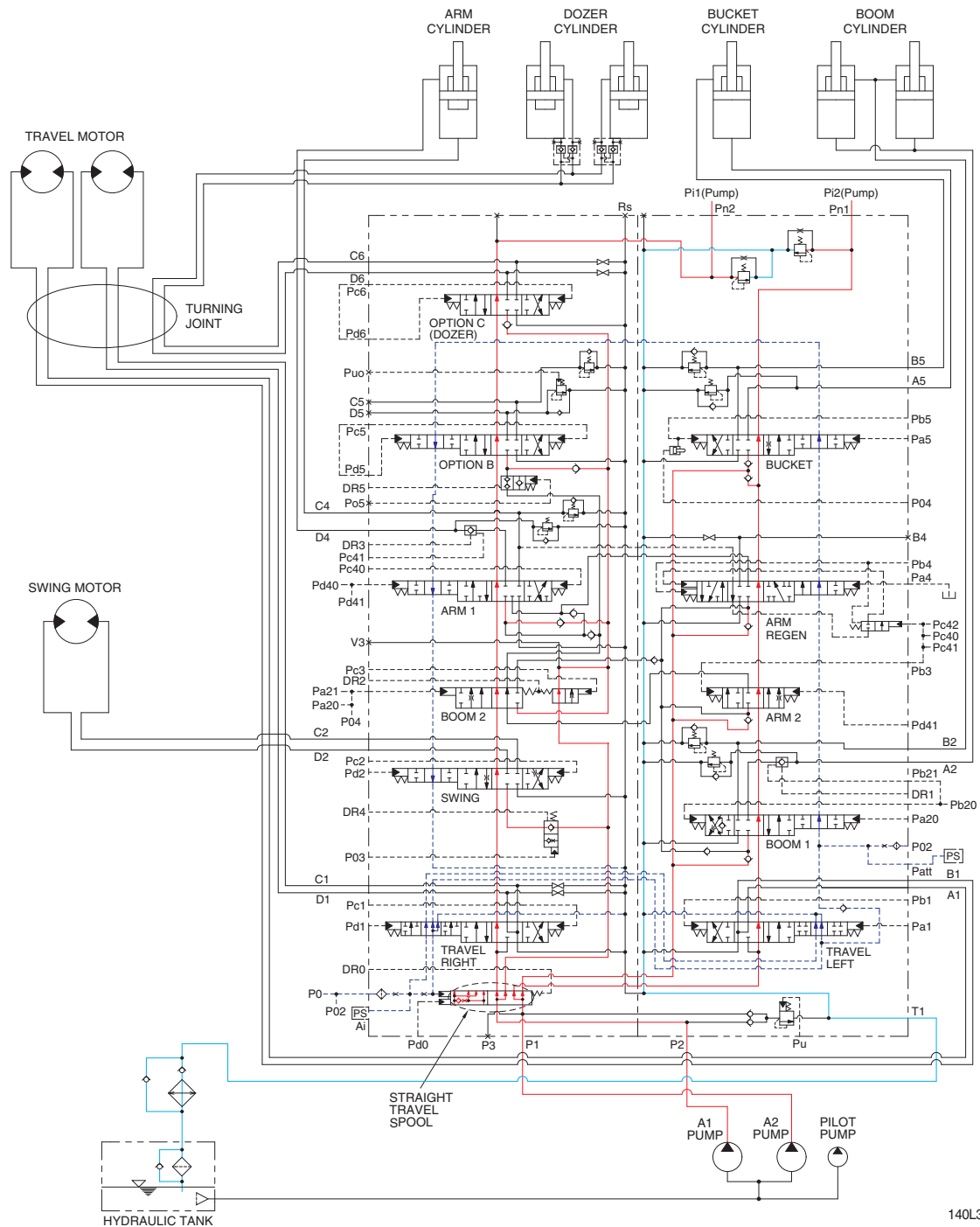

140L3HC23

The oil from the A1 and A2 pump flows through the neutral oil passage, bypass oil passage and confluence oil passage in the main control valve. Then the oil goes to each actuator and operates them. Check valves and orifices are located on these oil passage in the main control valve. These control the oil from the main pumps so as to correspond to the operation of each actuator and smooth the combined operation.

### STRAIGHT TRAVEL SPOOL

This straight travel spool for straight travel is provided in the main control valve.

If any actuator is operated when traveling, the straight travel spool is pushed to the right by the pilot oil pressure.

Consequently, the left and right travel oil supply passage are connected, and equivalent amount of oil flows into the left and right travel motors. This keeps the straight travel.

## 2. COMBINED SWING AND BOOM UP OPERATION

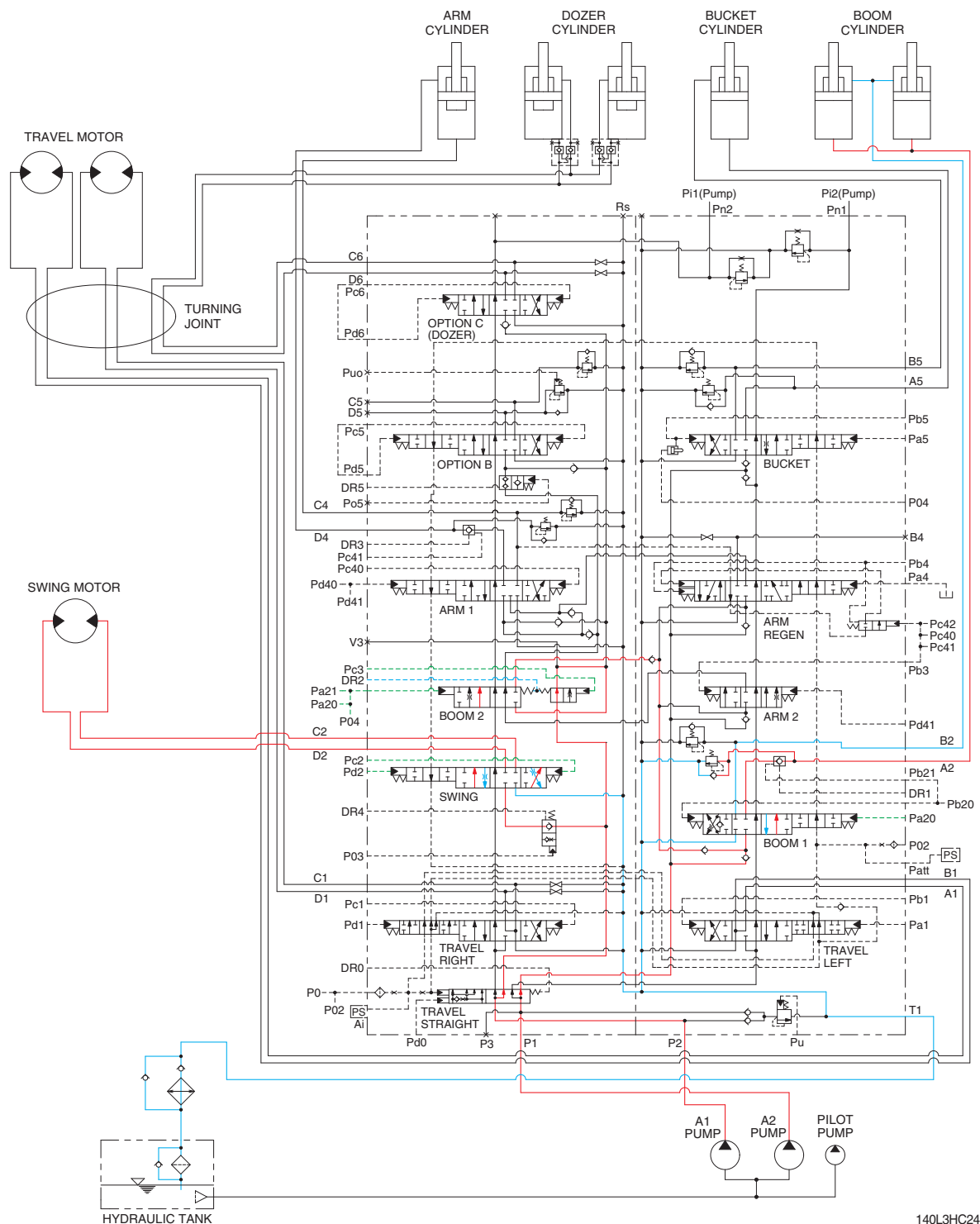

140L3HC24

When the swing and boom up functions are operated simultaneously, the swing spool and boom spools in the main control valve are moved to the functional position by the pilot oil pressure from the remote control valve.

The oil from the A1 pump flows into the swing motor through swing spool and the boom cylinder through boom 2 spool.

The oil from the A2 pump flows into the boom cylinders through the boom 1 spool in the right control valve.

The super structure swings and the boom is operated.

Refer to page 3-8 for the boom priority system.

### 3. COMBINED SWING AND ARM OPERATION

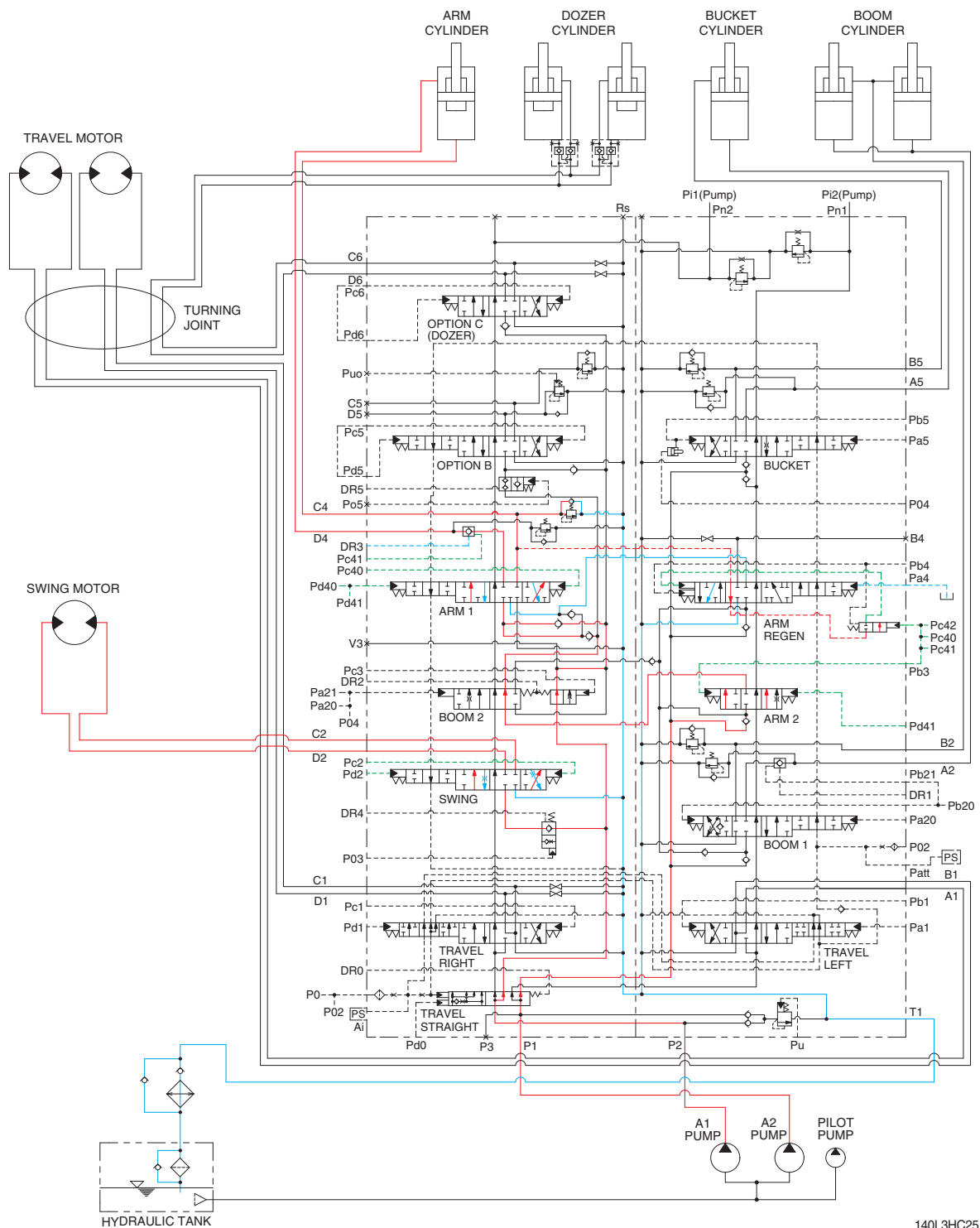

140L3HC25

When the swing and arm functions are operated simultaneously, the swing spool and arm spools in the main control valve are moved to the functional position by the pilot oil pressure from the remote control valve.

The oil from the A1 pump flows into the swing motor through swing spool and the arm cylinder through arm 1 spool.

The oil from the A2 pump flows into the arm cylinder through the arm 2 spool of the right control valve.

The super structure swings and the arm is operated.

Refer to page 3-13 for the swing operation preference function.

#### 4. COMBINED SWING AND BUCKET OPERATION

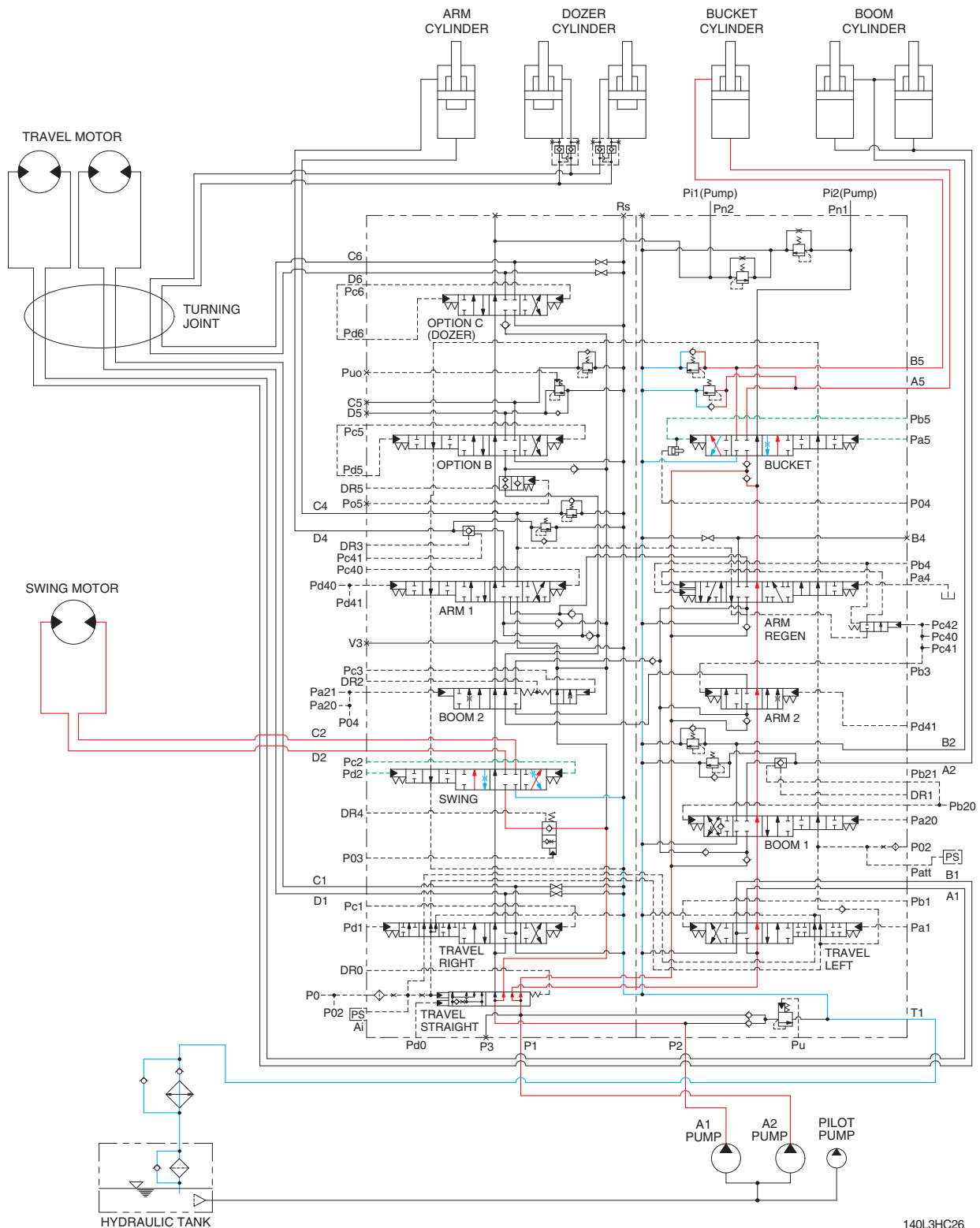

140L3HC26

When the swing and bucket functions are operated simultaneously, the swing spool and bucket spool in the main control valve are moved to the functional position by the pilot oil pressure from the remote control valve.

The oil from the A1 pump flows into the swing motor through the swing spool in the left control valve. The oil from the A2 pump flows into the bucket cylinder through the bucket spool in the right control valve.

The super structure swings and the bucket is operated.

## 5. COMBINED SWING AND TRAVEL OPERATION

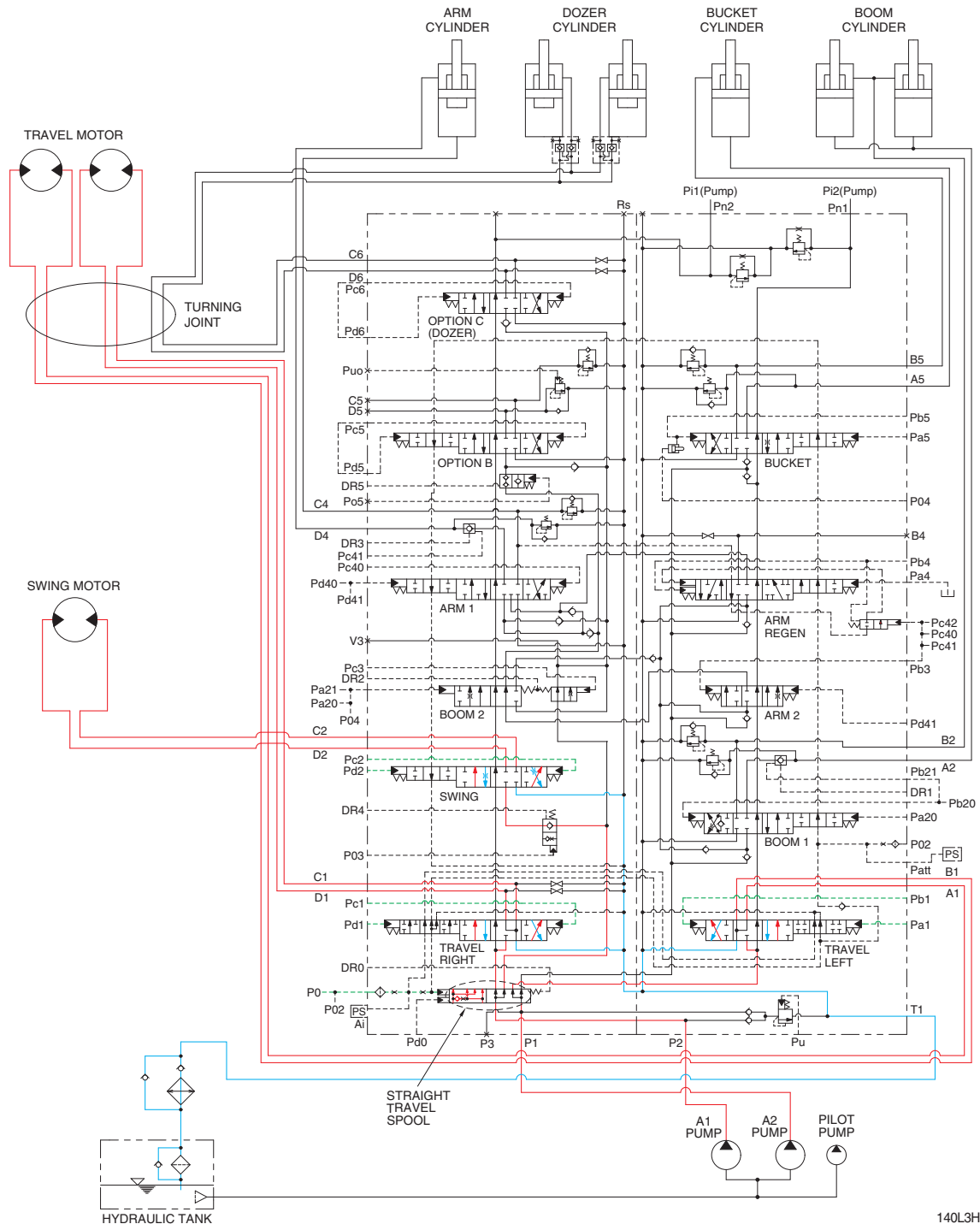

140L3HC27

When the swing and travel functions are operated simultaneously, the swing spool and travel spools in the main control valve are moved to the functional position by the pilot oil pressure from the remote control valve and straight travel spool is pushed to the right by the pilot oil pressure from the pilot pump.

The oil from the A1 pump flows into the travel motors through the RH travel spool of the left control valve and the LH travel spool of the right control valve via the straight travel spool.

The oil from the A2 pump flows into the swing motor through in the straight travel spool.

When the pressure of the travel motors is lower than the pressure of the swing motor, some oil from the A2 pump flows into the travel motors through the check valve and orifice in the straight travel spool. This prevents the rapid slowdown of the travel.

The upper structure swings and the machine travels straight.



## 6. COMBINED BOOM AND TRAVEL OPERATION

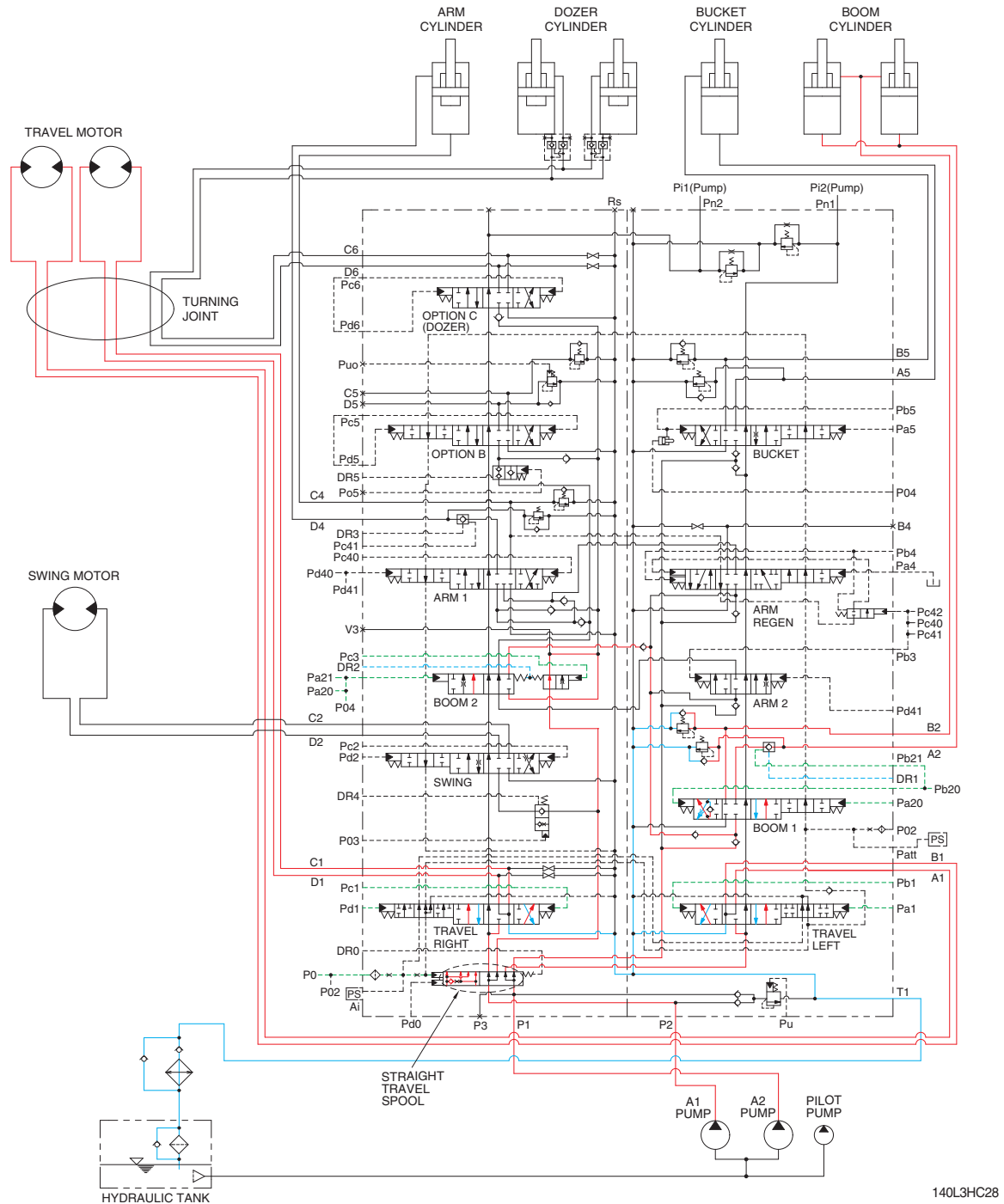

140L3HC28

When the boom and travel functions are operated simultaneously, the boom spools and travel spools in the main control valve are moved to the functional position by the pilot oil pressure from the remote control valve and the straight travel spool is pushed to the right by the oil pressure from pilot pump.

The oil from the A1 pump flows into the travel motors through the RH travel spool of the left control valve and the LH travel spool of the right control valve via the straight travel spool.

The oil from the A2 pump flows into the boom cylinders through the boom 2 spool and boom 1 spool via the parallel and confluence oil passage in case boom up operation.

When the pressure of the travel motors is lower than the pressure of the boom cylinders, some oil from the A2 pump flows into the travel motors through the check valve and orifice in the straight travel spool. This prevents the rapid slowdown of the travel.

The boom is operated and the machine travels straight.

## 7. COMBINED ARM AND TRAVEL OPERATION

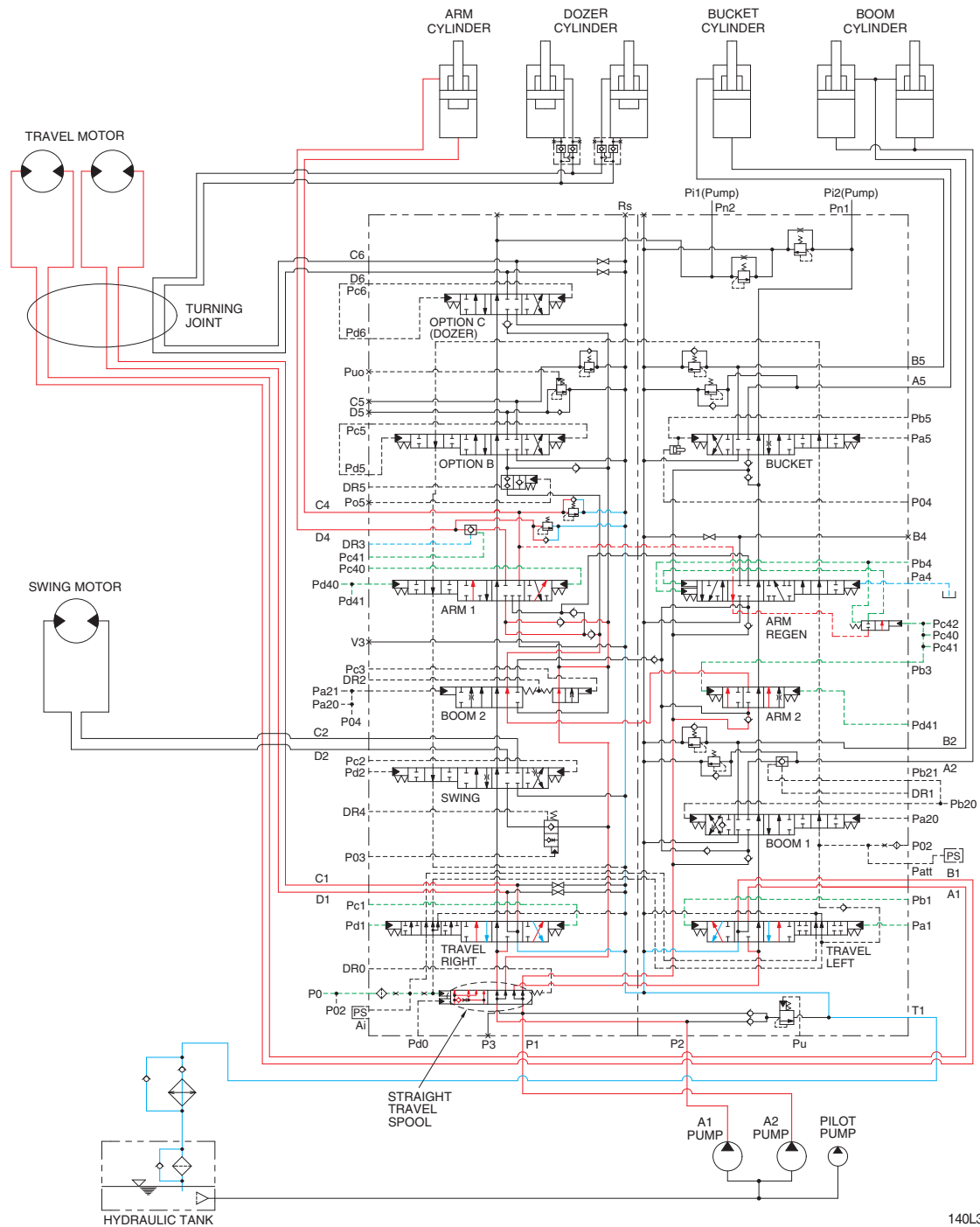

When the arm and travel functions are operated simultaneously, the arm spools and travel spools in the main control valve are moved to the functional position by the pilot oil pressure from the remote control valve and the straight travel spool is pushed to the right by the oil pressure from pilot pump. The oil from the A1 pump flows into the travel motors through the RH travel spool of the left control valve and the LH travel spool of the right control valve via the straight travel spool. The oil from the A2 pump flows into the arm cylinders through the arm 1 spool and arm 2 spool via the parallel and confluence oil passage. When the pressure of the travel motors is lower than the pressure of the arm cylinder, some oil from the A2 pump flows into the travel motors through the check valve and orifice in the straight travel spool. This prevents the rapid slowdown of the travel. The arm is operated and the machine travels straight.

## 8. COMBINED BUCKET AND TRAVEL OPERATION

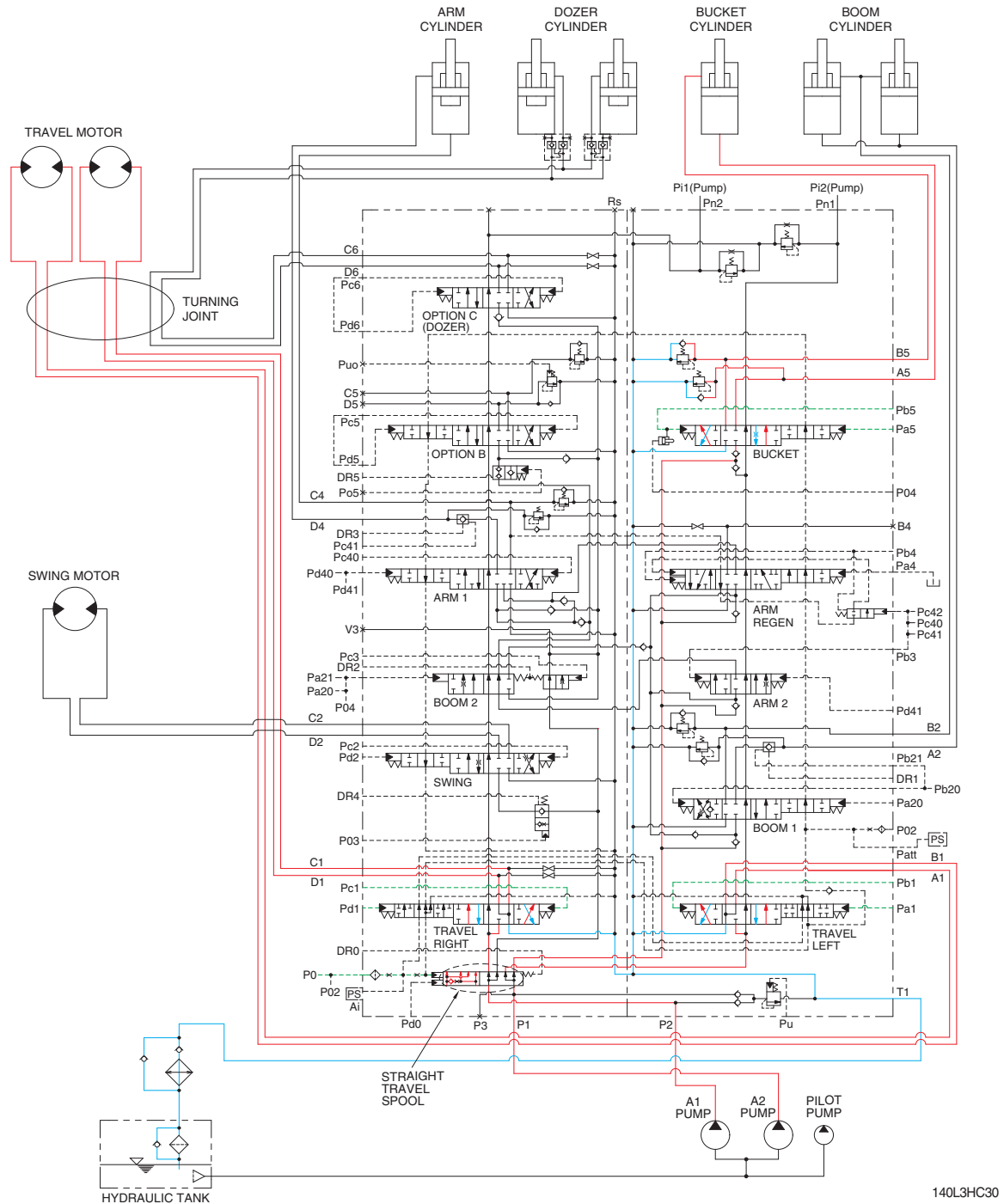

When the bucket and travel functions are operated simultaneously, the bucket spool and travel spools in the main control valve are moved to the functional position by the pilot oil pressure from the remote control valve, and the straight travel spool is pushed to the right by the oil pressure from pilot pump. The oil from the A1 pump flows into the travel motors through the RH travel spool of the left control valve and the LH travel spool of the right control valve via the straight travel spool of the control valve.

The oil from the A2 pump flows into the bucket cylinder through the bucket spool via the confluence oil passage.

When the pressure of the travel motors is lower than the pressure of the bucket cylinder, some oil from the A2 pump flows into the travel motors through the check valve and orifice in the straight travel spool. This prevents the rapid slowdown of the travel.

The bucket is operated and the machine travels straight.

## 9. COMBINED BOOM UP AND BUCKET OPERATION

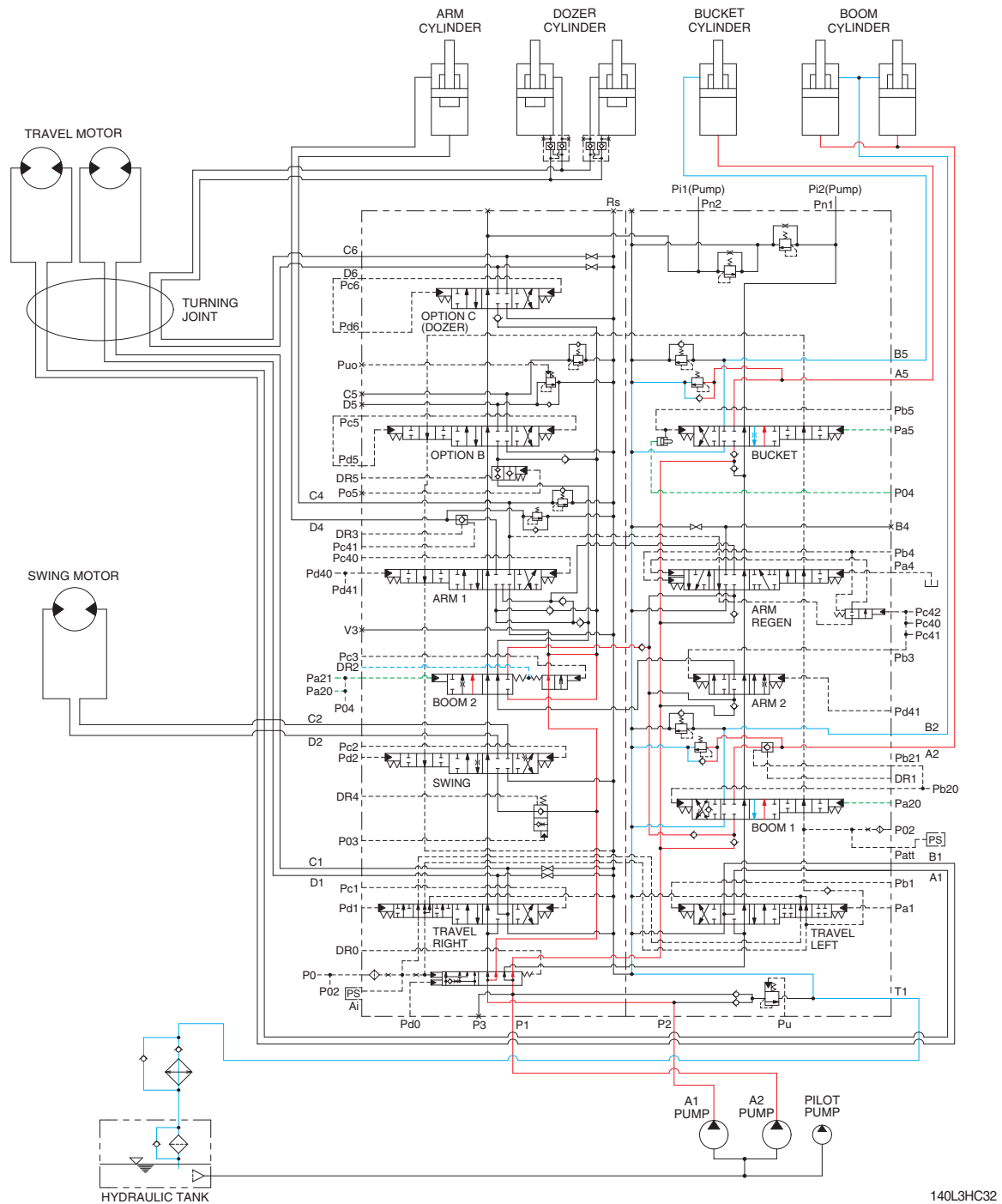

140L3HC32

When the boom up and bucket functions are operated simultaneously, each spool in the main control valve is moved to the functional position by the pilot oil pressure from the remote control valve.

The oil from the A1 pump flows into the boom cylinders through the boom 2 spool in the left control valve. The oil from the A2 pump flows into the boom cylinders and bucket cylinder through the boom 1 spool, bucket spool and the parallel and confluence oil passage in the right control valve.

Also, when the boom up and bucket in functions are operated simultaneously, the boom up operation preference function is operated by the pilot pressure P04 and then the bucket spool transfers in the half stroke not full stroke (refer to page 2-33). Therefore, the most of pressurized oil flows into boom 1 spool than the bucket spool to make the boom up operation more preferential.

The boom and bucket are operated.