

SECTION 4 ELECTRICAL SYSTEM

Group 1 Component Location	4-1
Group 2 Electrical Circuit	4-3
Group 3 Electrical Component Specification	4-22
Group 4 Connectors	4-34

SECTION 4 ELECTRICAL SYSTEM

GROUP 1 COMPONENT LOCATION

1. LOCATION 1

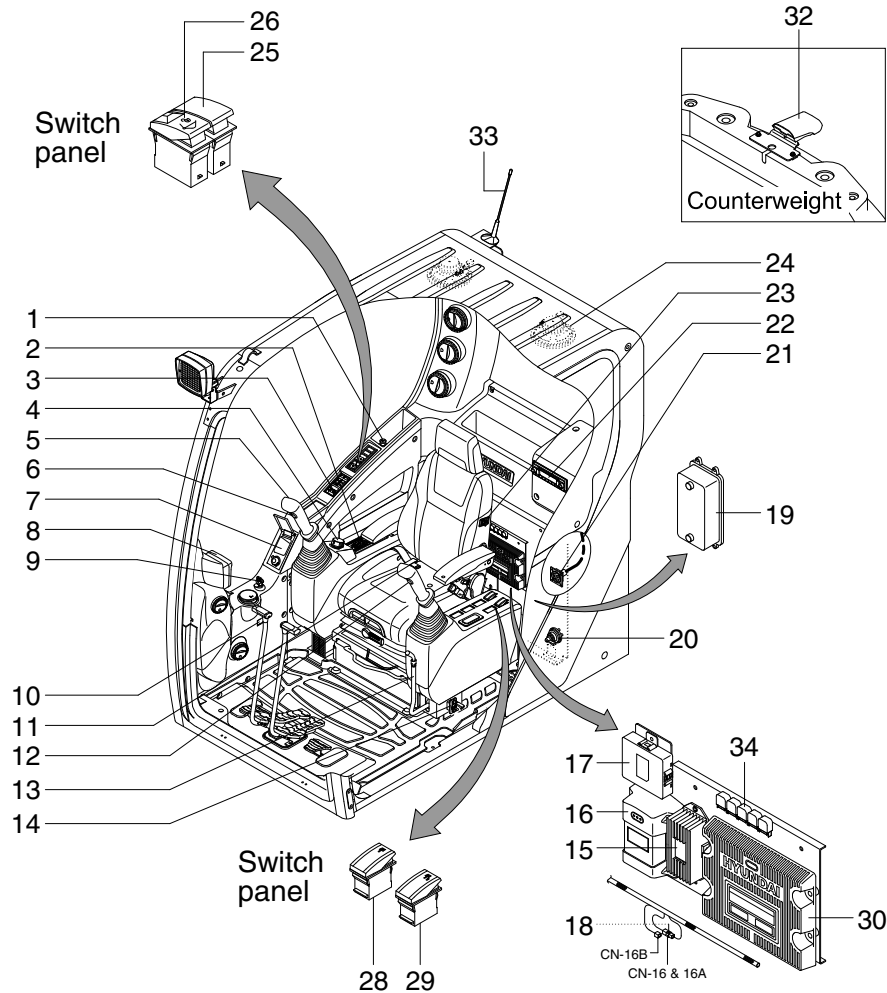

145ZF4EL01

- | | | |
|----------------------------|---------------------------------|-----------------------------|
| 1 Cigar lighter | 12 Power max switch | 23 Heated seat switch |
| 2 Aircon and heater switch | 13 Safety lever | 24 Speaker |
| 3 Remote controller | 14 Emergency engine stop switch | 25 Option attachment switch |
| 4 Accel dial switch | 15 DC/DC converter | 26 Quick clamp switch |
| 5 Horn switch | 16 Remote controller unit | 28 Swing fine switch |
| 6 Breaker operation switch | 17 Handsfree control unit | 29 Swing lock switch |
| 7 USB & socket assy | 18 Emergency engine connector | 30 Machine control unit |
| 8 Cluster | 19 Fuse & relay box | 32 Rear view camera |
| 9 Start switch | 20 Master switch | 33 Satellite antenna |
| 10 Service meter | 21 RS232 & J1939 service socket | 34 Relay - 5P |
| 11 One touch decel switch | 22 Radio & USB player | |

2. LOCATION 2

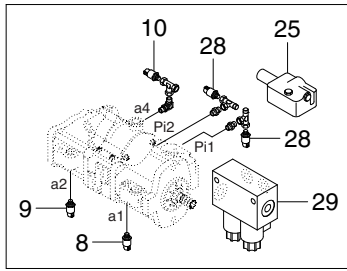

MAIN PUMP

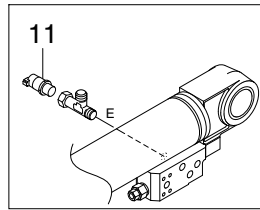

BOOM SAFETY VALVE

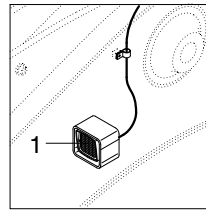

BOOM

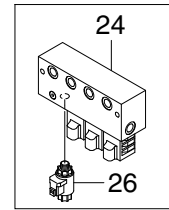

4 CARTRIDGE VALVE

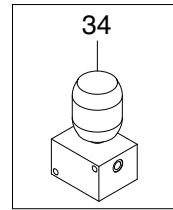

SAFETY SOL VALVE

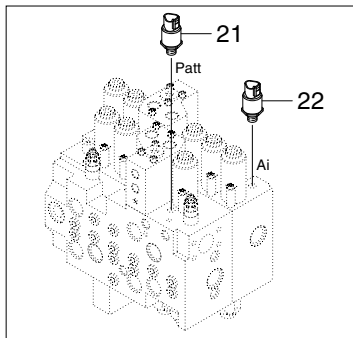
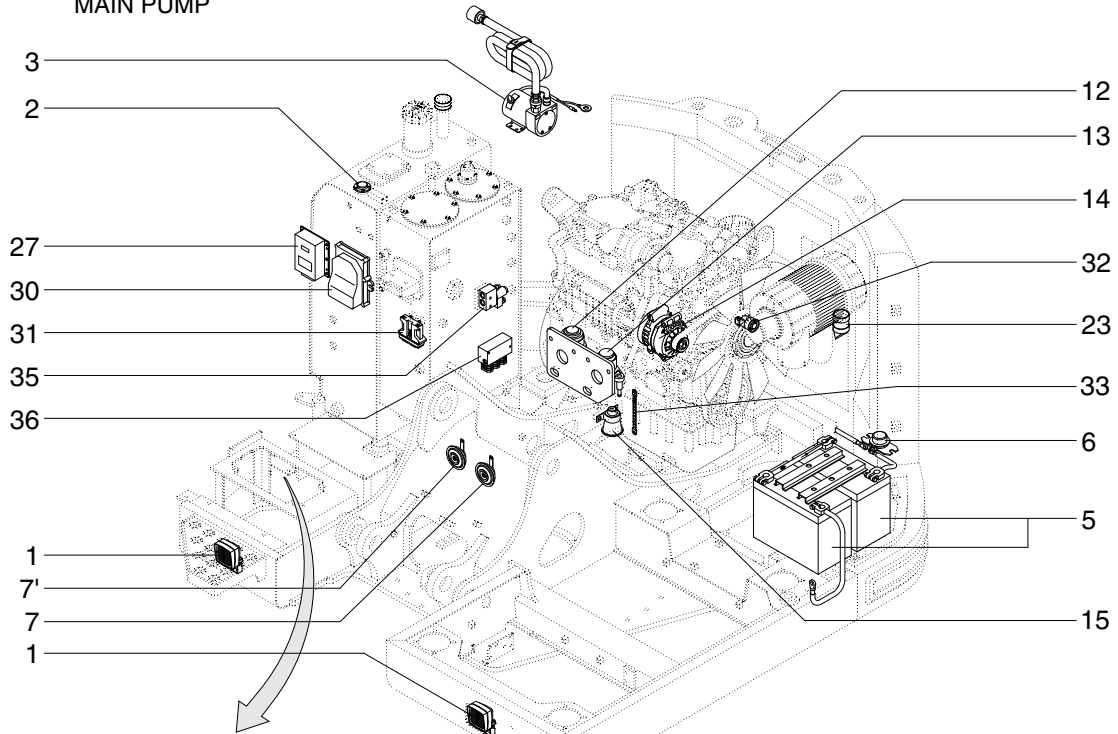

MAIN CONTROL VALVE

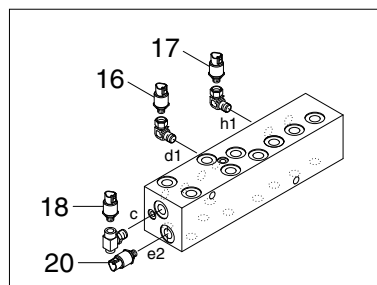

SHUTTLE BLOCK

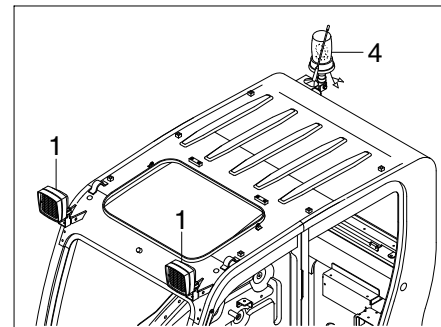

CAB

145ZF4EL02

- | | | |
|-----------------------------|----------------------------------|----------------------------------|
| 1 Lamp | 12 Start relay | 25 Pump EPPR valve |
| 2 Fuel sender | 13 Heater relay | 26 Boom priority EPPR valve |
| 3 Fuel filler pump | 14 Alternator | 27 Machine control unit - attach |
| 4 Beacon lamp | 15 Travel alarm buzzer | 28 Nega-control pressure sensor |
| 5 Battery | 16 Arm/Bucket in pressure sensor | 29 Flow control EPPR valve |
| 6 Battery relay | 17 Boom up pressure sensor | 30 Relay drive unit |
| 7 Horn - high | 18 Swing pressure sensor | 31 PVG 32 controller |
| 7' Horn - low | 20 Arm in pressure sensor | 32 Air cleaner indicator |
| 8 P1 pressure sensor | 21 Attach pressure sensor | 33 Earth strap |
| 9 P2 pressure sensor | 22 Travel pressure sensor | 34 Safety solenoid valve |
| 10 EPPR pressure sensor | 23 Air cleaner sensor | 35 Swing fine solenoid valve |
| 11 Overload pressure sensor | 24 4 cartridge valve | 36 Swing lock solenoid valve |

GROUP 2 ELECTRICAL CIRCUIT (1/2)

ELECTRICAL CIRCUIT (1/4, SERIAL NO. : -#0967)

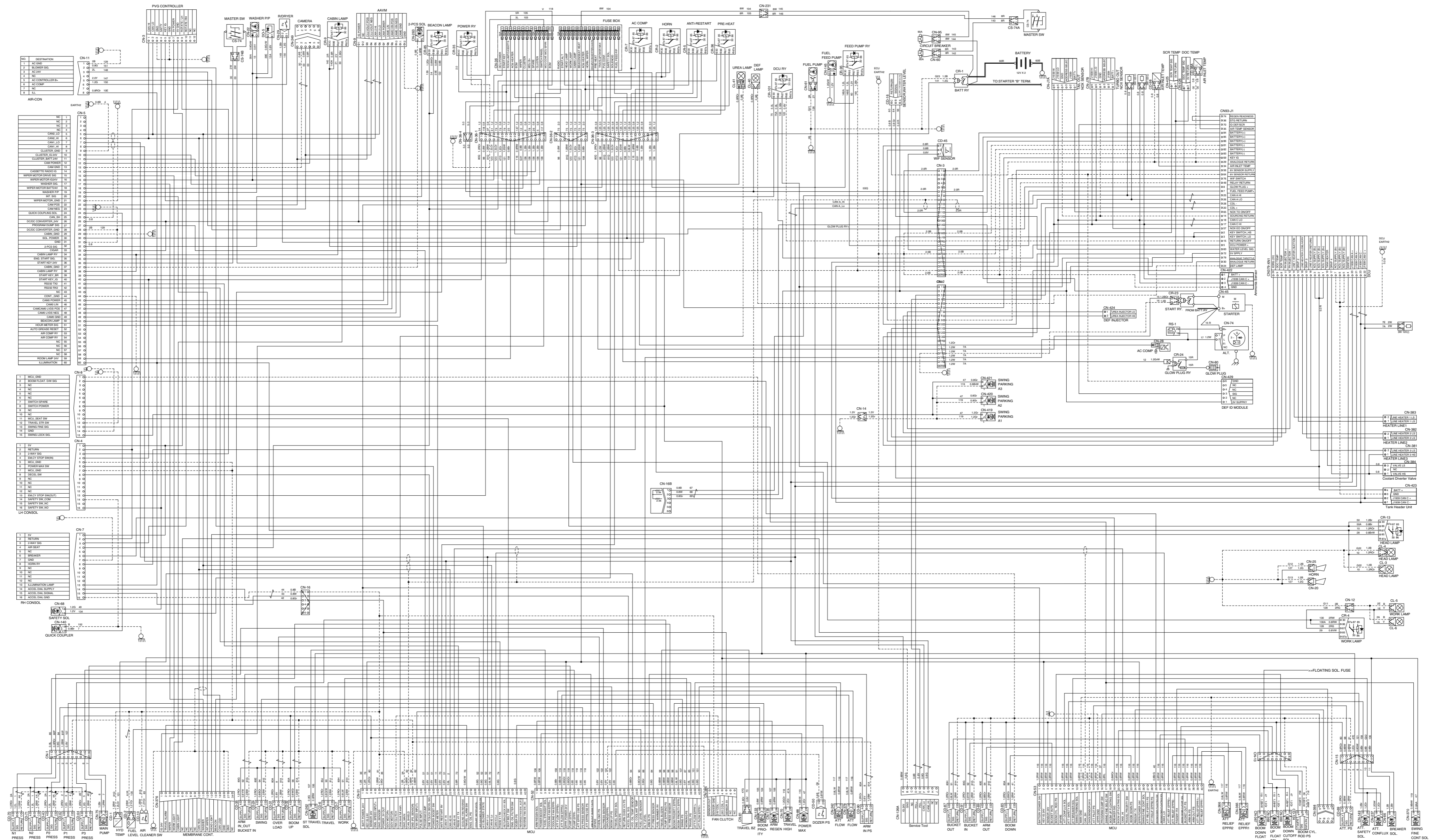

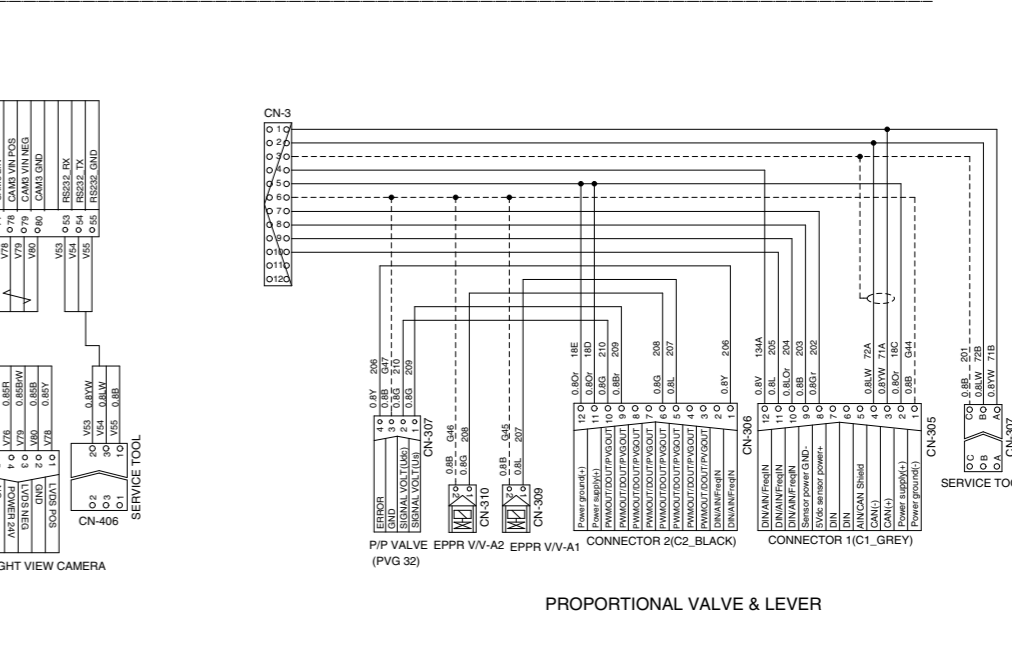
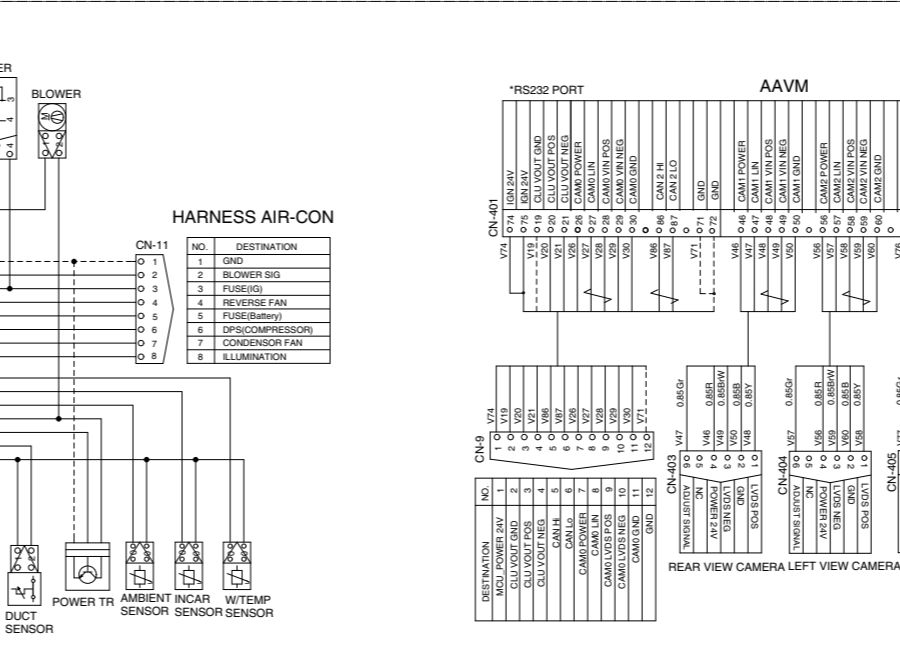
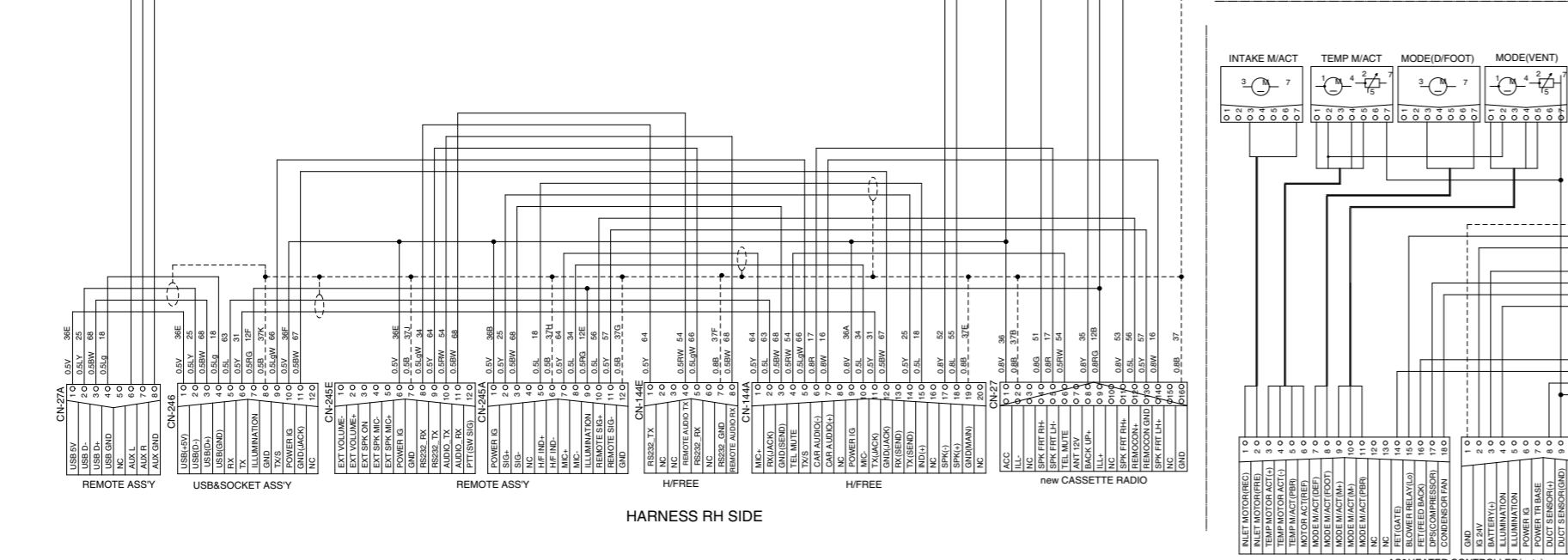
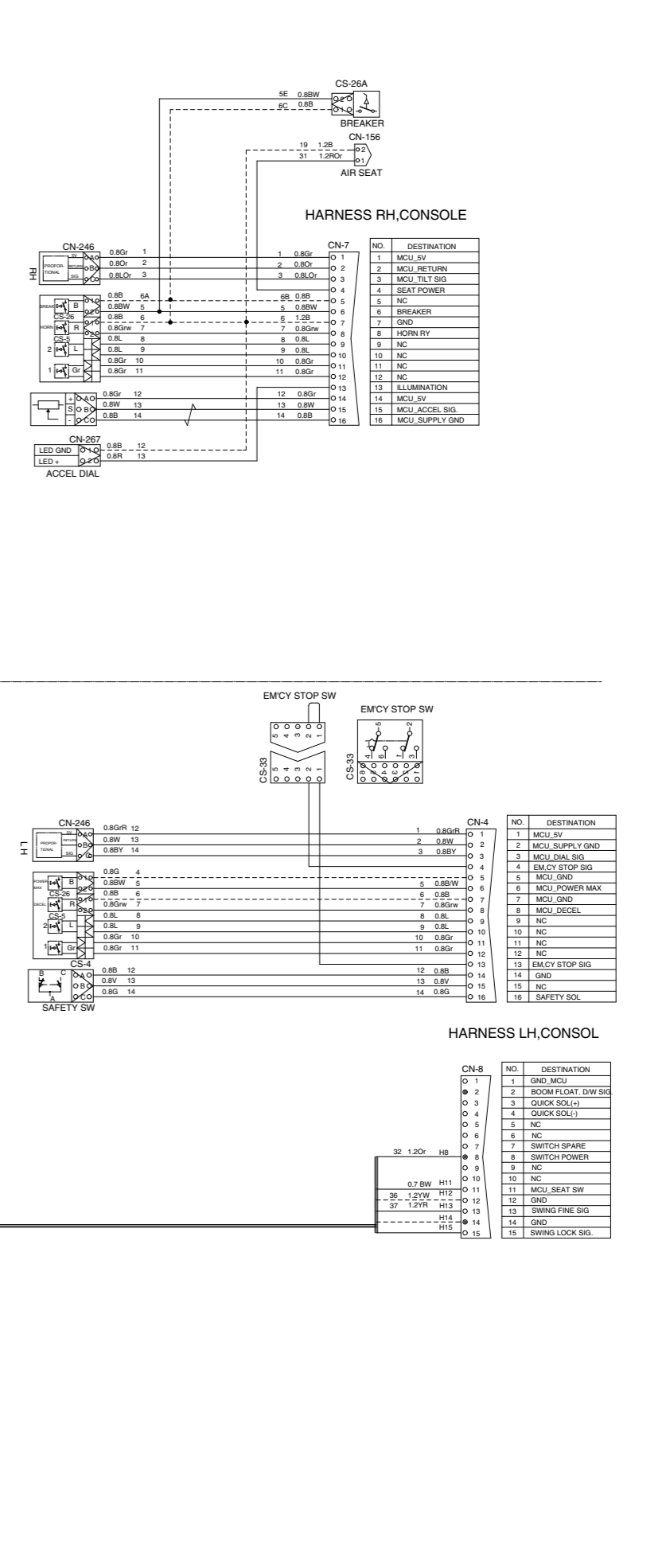
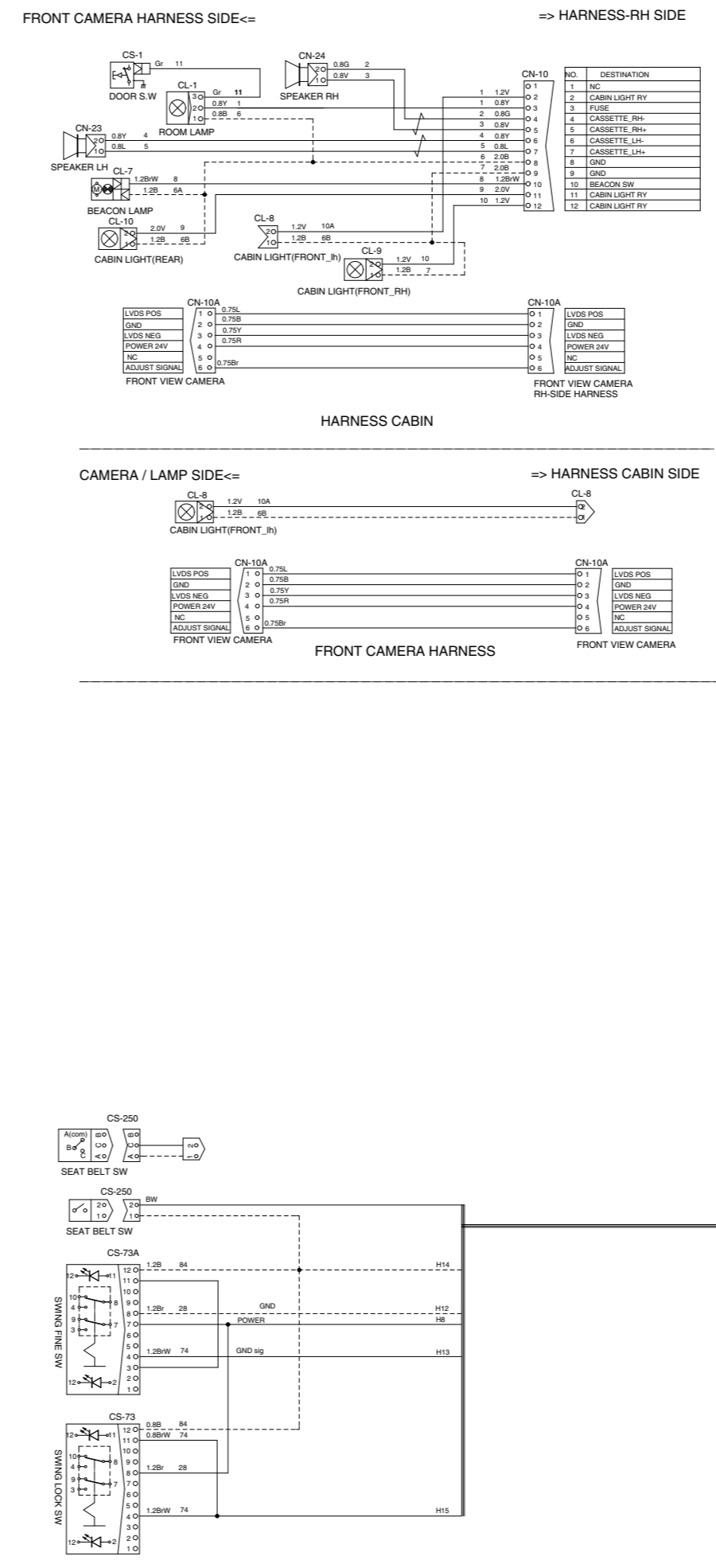
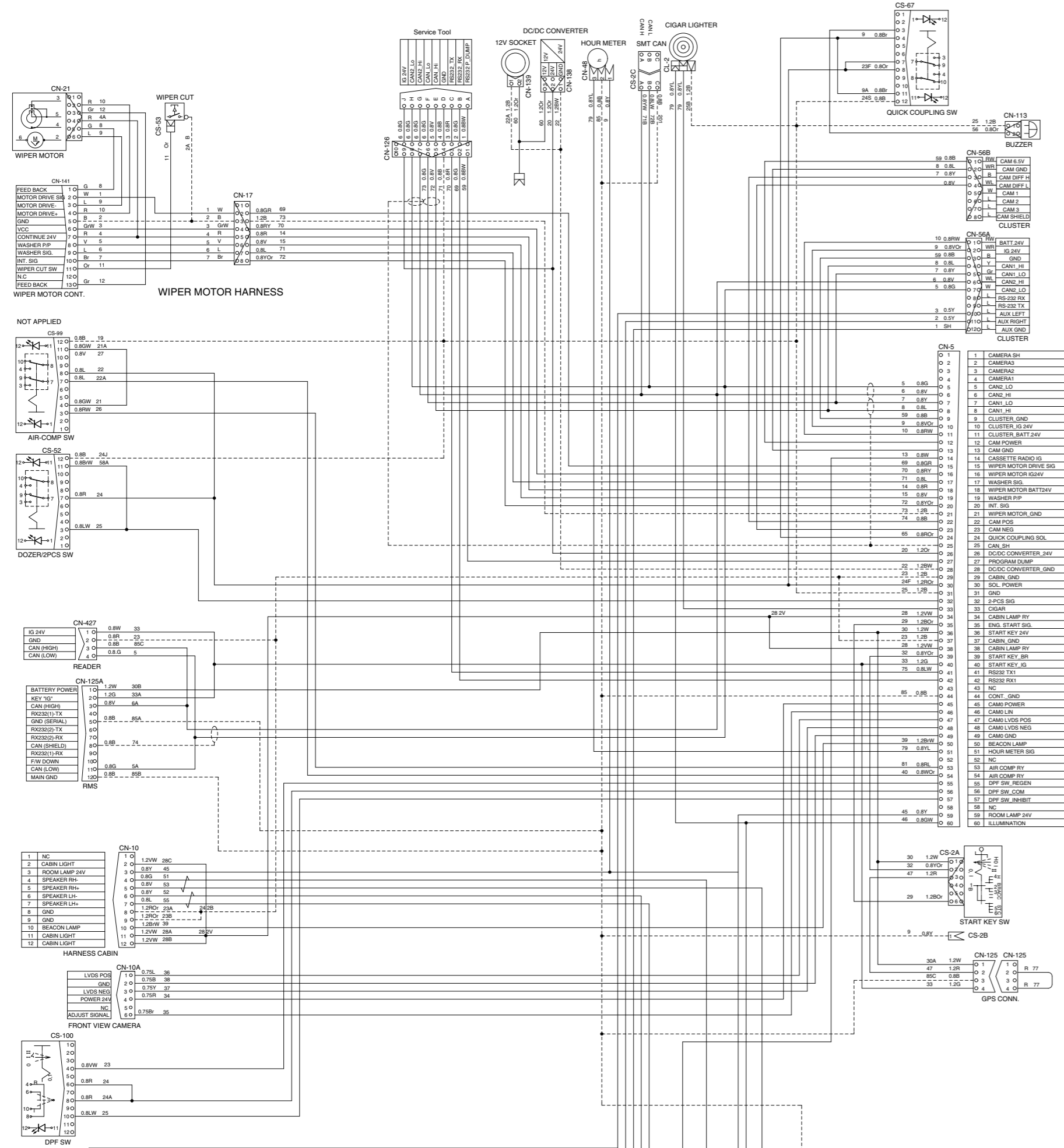

ELECTRICAL CIRCUIT (3/4, SERIAL NO. : #0968-)

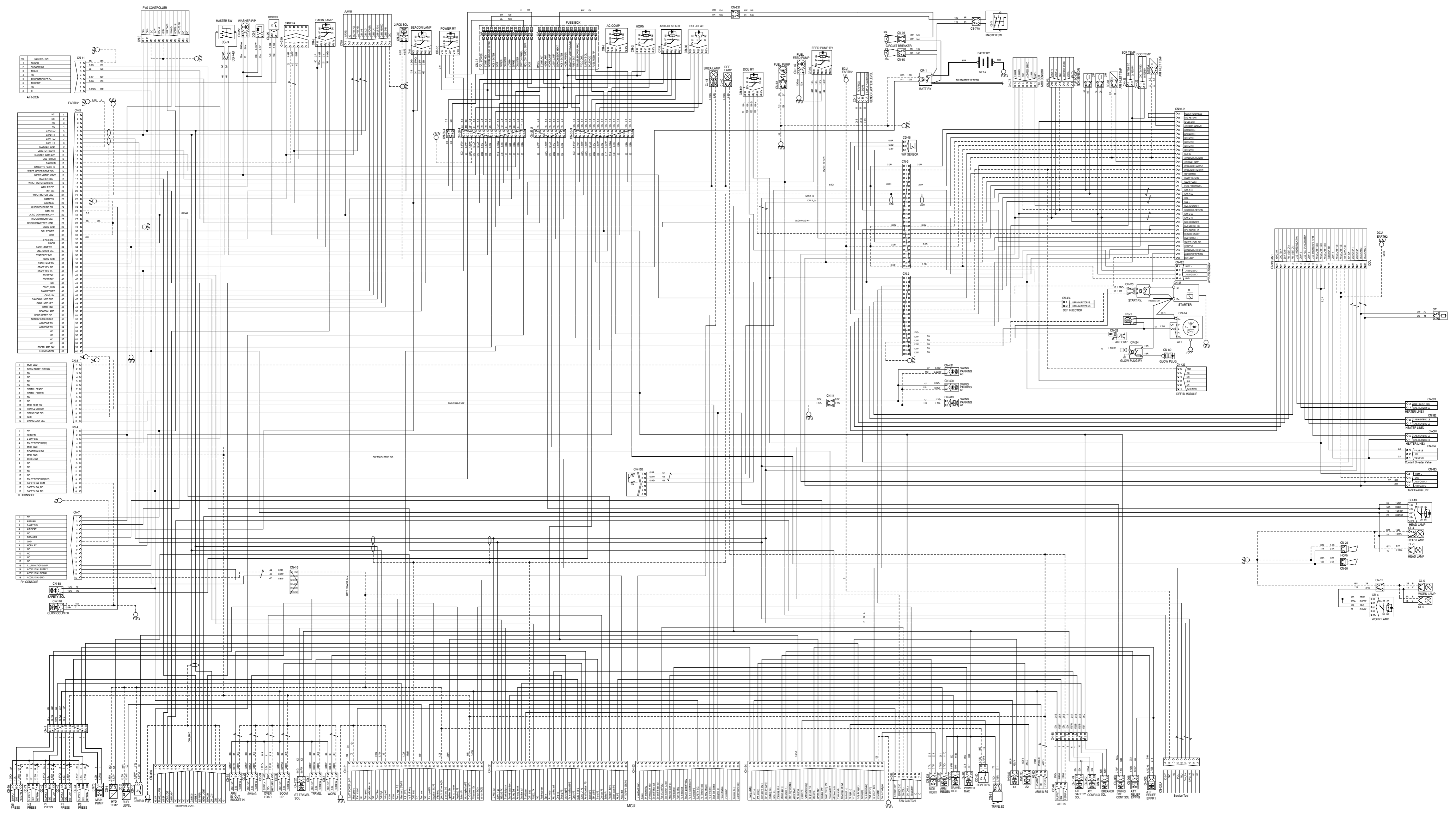

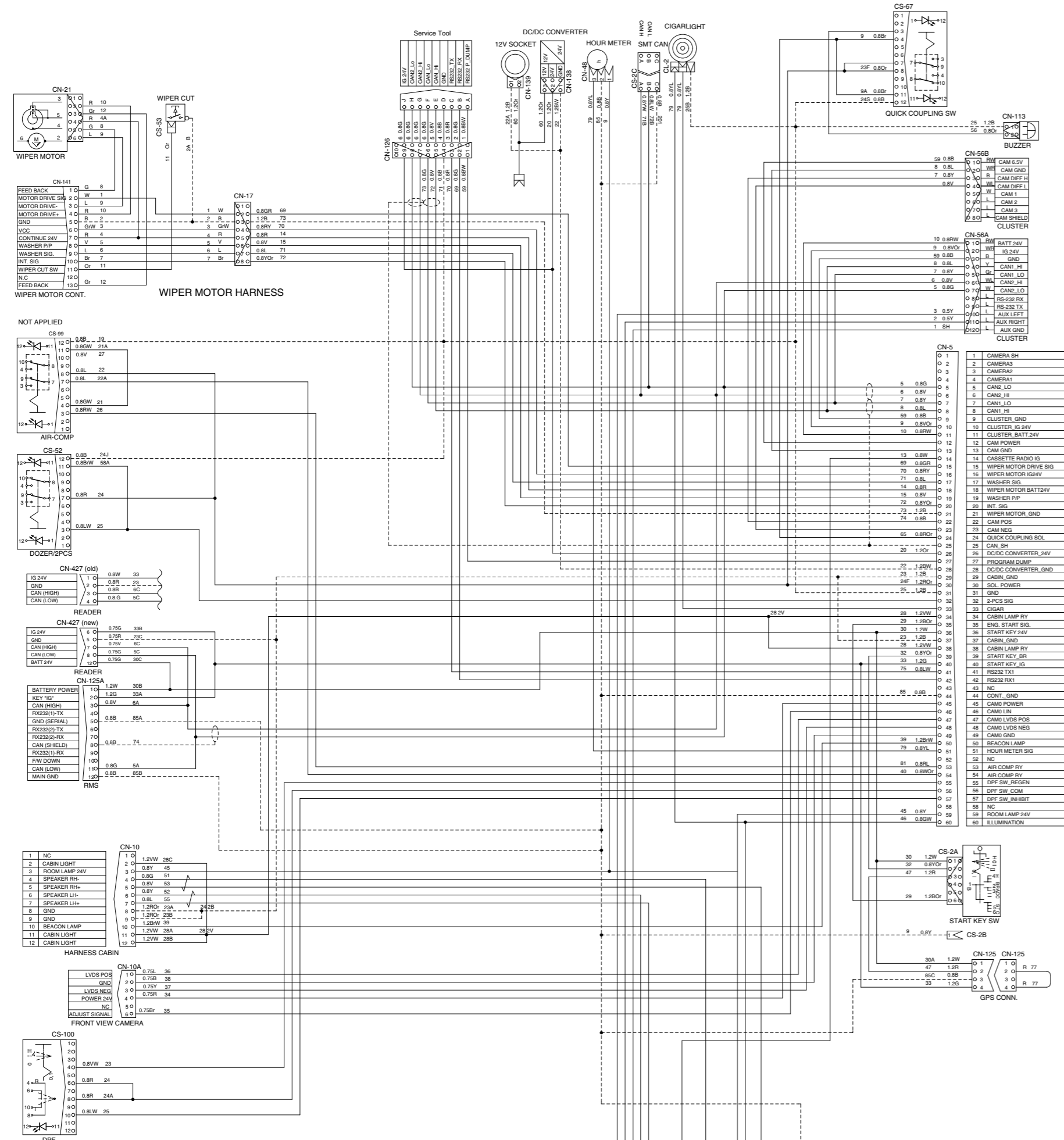

FRONT CAMERA HARNESS SIDE <=> HARNESS-RH SIDE

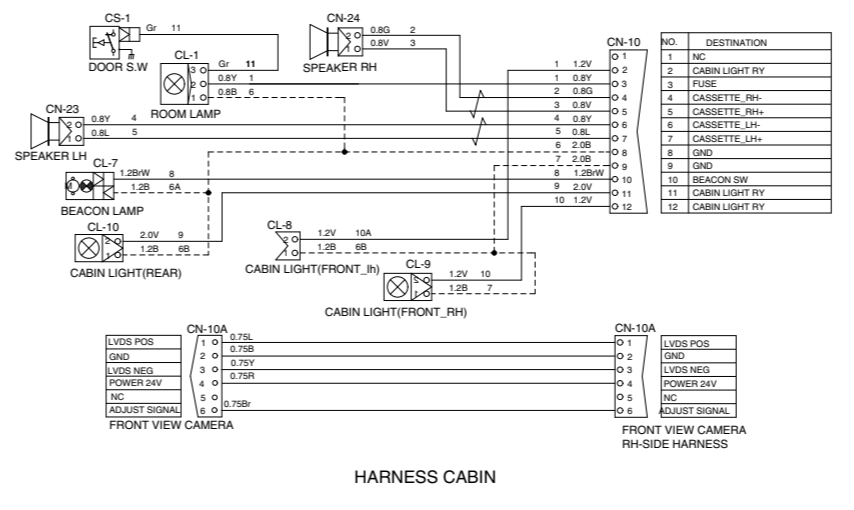

HARNESS RH, CONSOL

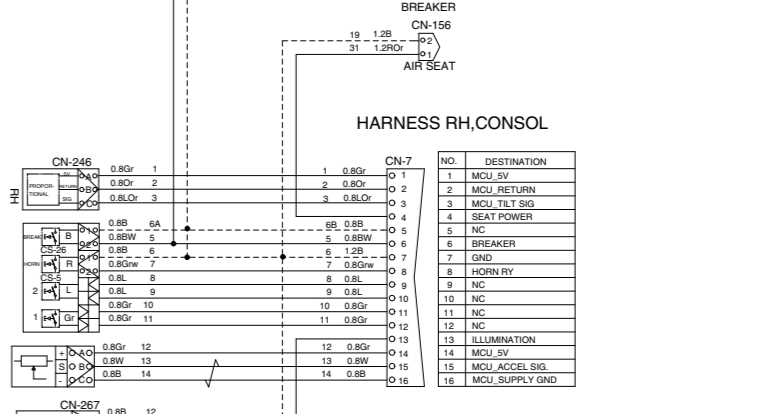

CAMERA / LAMP SIDE <=> HARNESS CABIN SIDE

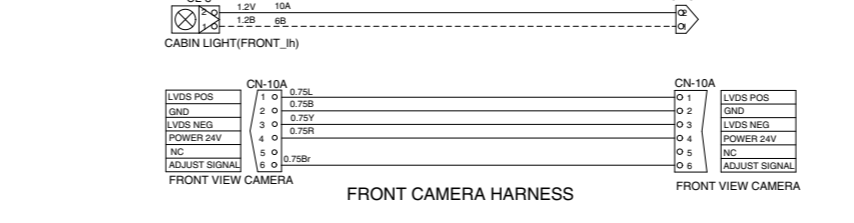

HARNESS LH, CONSOL

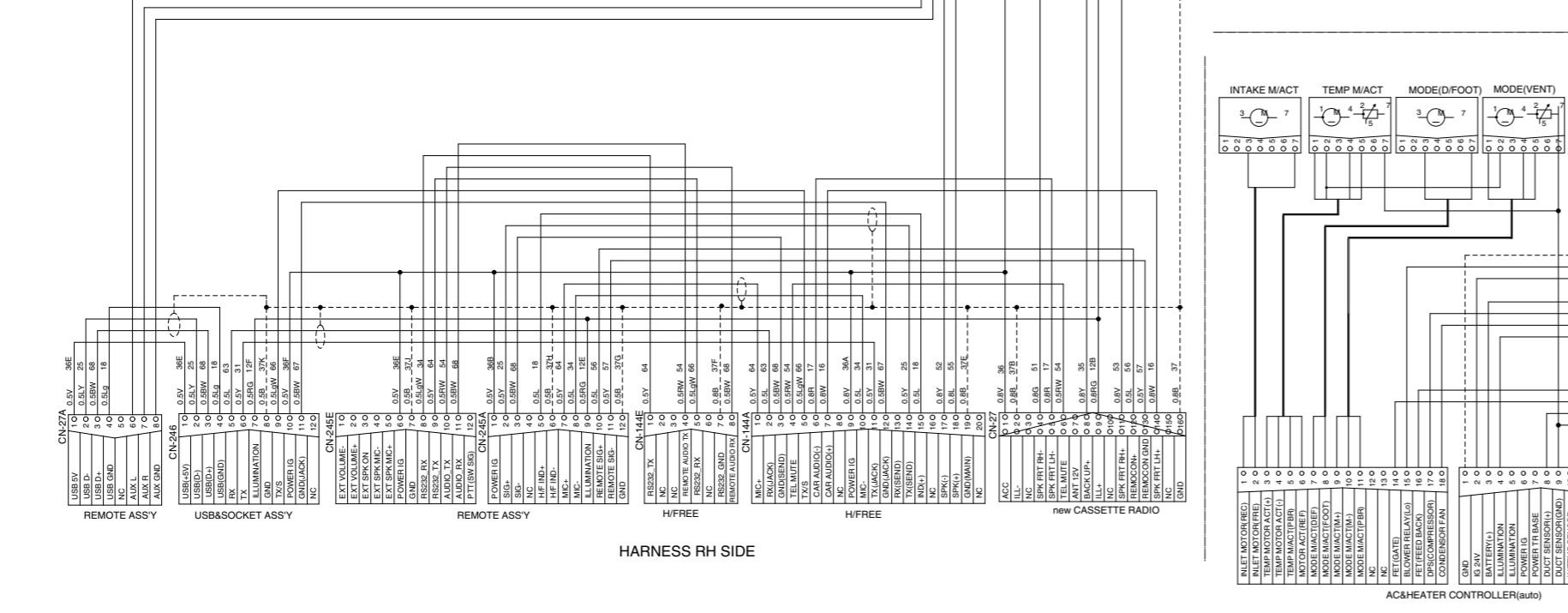
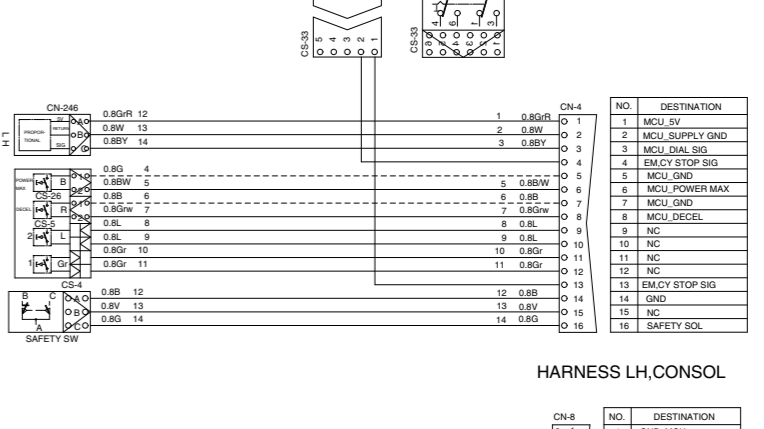

MEMORANDUM

1. POWER CIRCUIT

The negative terminal of battery is grounded to the machine chassis.

When the start switch is in the OFF position, the current flows from the positive battery terminal as shown below.

1) OPERATING FLOW

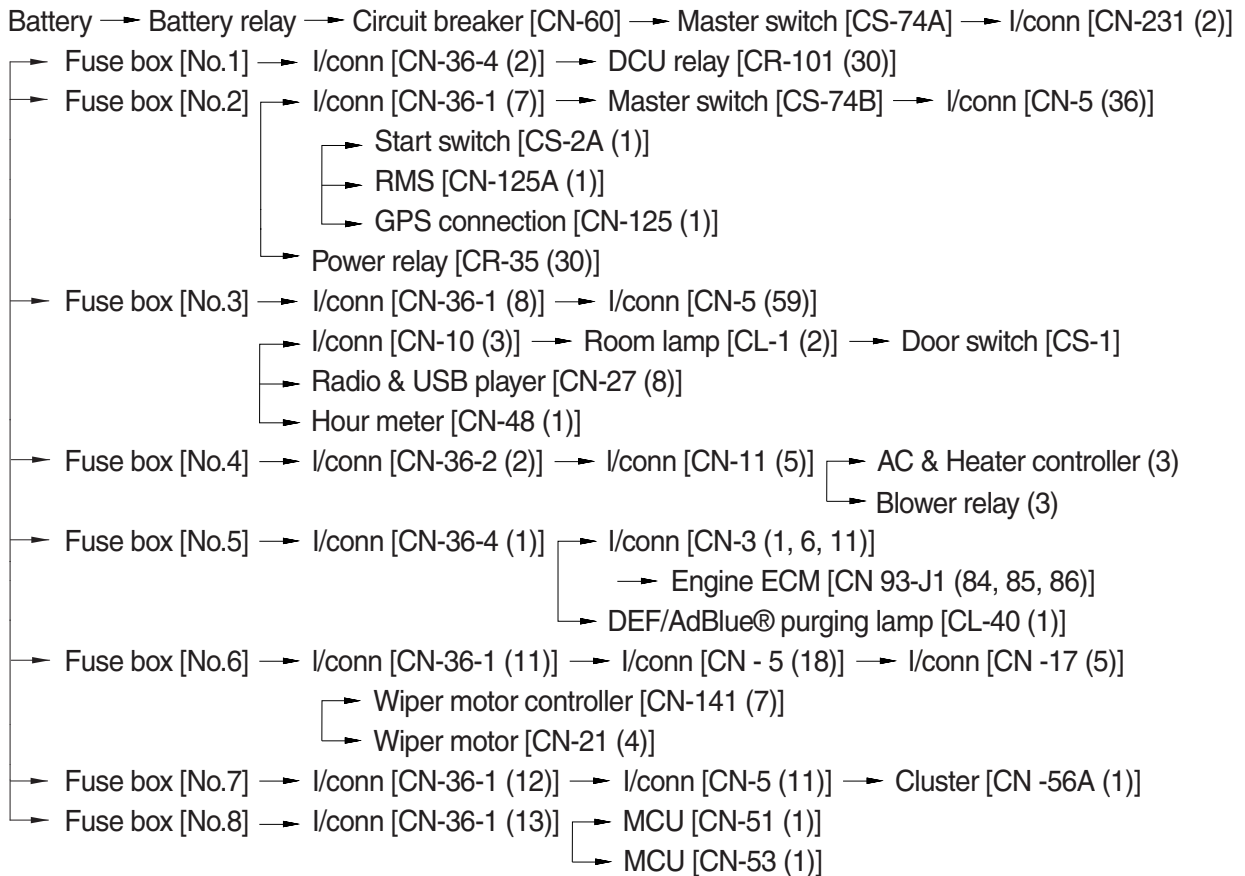

※ I/conn : Intermediate connector

2) CHECK POINT

Engine	Start switch	Check point	Voltage
OFF	OFF	① - GND (battery 1EA)	10~12.5V
		② - GND (battery 2EA)	20~25V
		③ - GND (battery relay)	20~25V
		④ - GND (circuit breaker)	20~25V

※ GND : Ground

POWER CIRCUIT

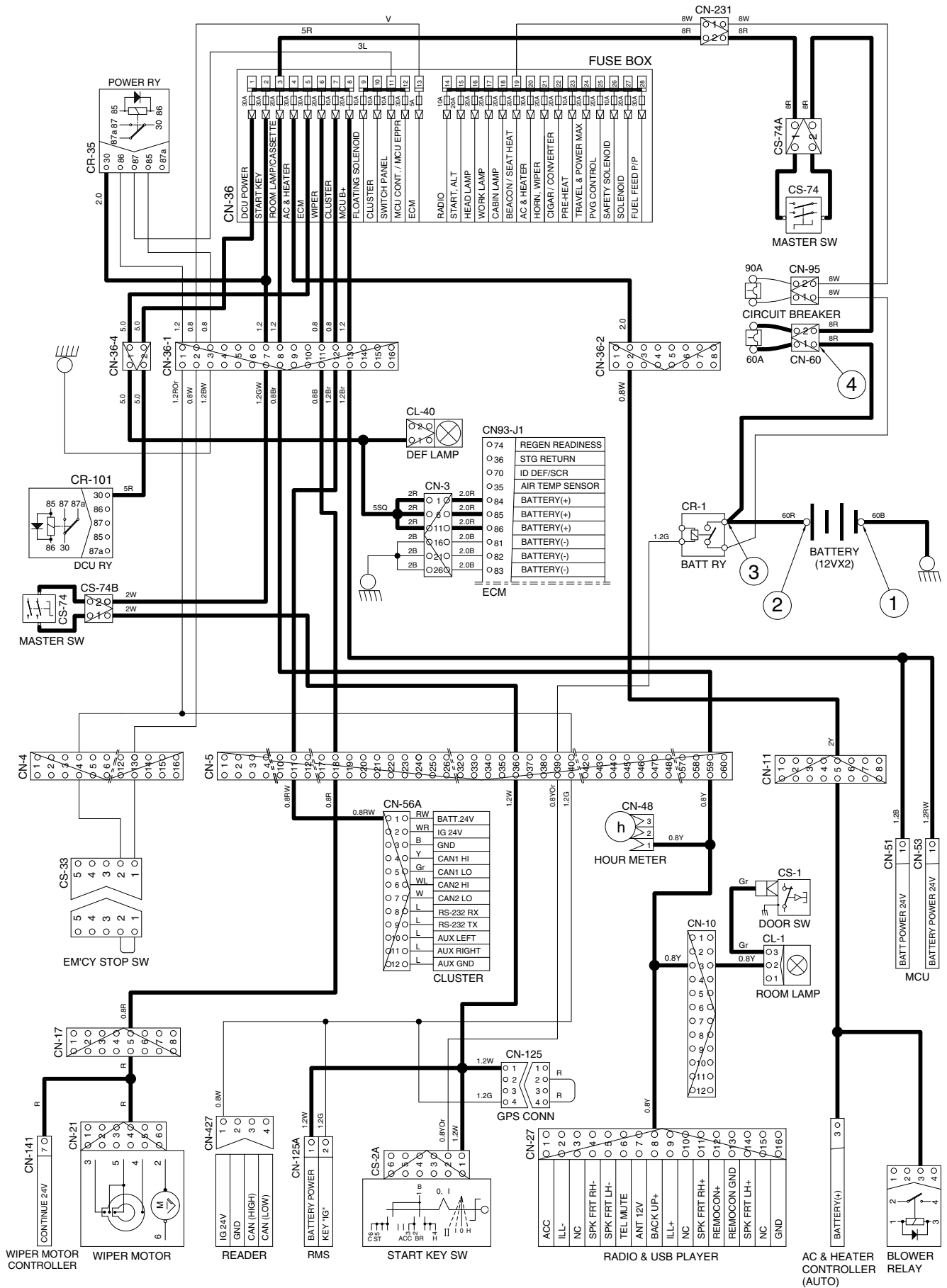

145ZF4EL05

2. STARTING CIRCUIT

1) OPERATING FLOW

Battery (+) terminal → Battery relay [CR-1] → Circuit breaker [CN-60] → Master switch [CS-74A]
 → I/conn [CN-231 (2)] → Fuse box [No.2] → I/conn [CN-36-1 (7)] → Master switch [CS-74B]
 → I/conn [CN-5 (36)] → Start switch [CS-2A (1)]

(1) When start key switch is in ON position

Start switch ON [CS-2A (2)] → I/conn [CN-5 (39)]
 → Battery relay [CR-1] → Battery relay operating (all power is supplied with the electric component)
 Start switch ON [CS-2A (3)] → GPS conn [CN-125 (2)→(4)]

I/conn [CN-5 (40)] → I/conn [CN-36-1 (1)] → Power relay [CR-35 (86)→(87)]
 → Fuse box [No.9~12]
 I/conn [CN-4 (4)] → Emergency engine stop sw [CS-33 (2)→(1)]
 → I/conn [CN-4 (13)] → I/conn [CN-36-1 (2)] → Fuse box [No. 13]
 → I/conn [CN-36-1 (6)] → I/conn [CN-2 (6)]
 → Engine ECM [CN 93-J1 (69)]

Reader [CN-427 (1)]
 RMS [CN-125A (2)]

(2) When start key switch is in START position

Start switch START [CS-2A (6)] → I/conn [CN-5 (35)] → I/conn [CN-36-3 (9)]
 → Anti-restart relay [CR-5 (86)→(87)] → I/conn [CN-36-3 (1)] → I/conn [CN-2 (16)]
 → Start relay [CR-23 (2)] → Starter motor operating

2) CHECK POINT

Engine	Start switch	Check point	Voltage
OPERATING	START	① - GND (battery) ② - GND (start key) ③ - GND (battery relay M4) ④ - GND (starter B ⁺) ⑤ - GND (starter M) ⑥ - GND (start relay) ⑦ - GND (battery relay M8)	20~25V

STARTING CIRCUIT

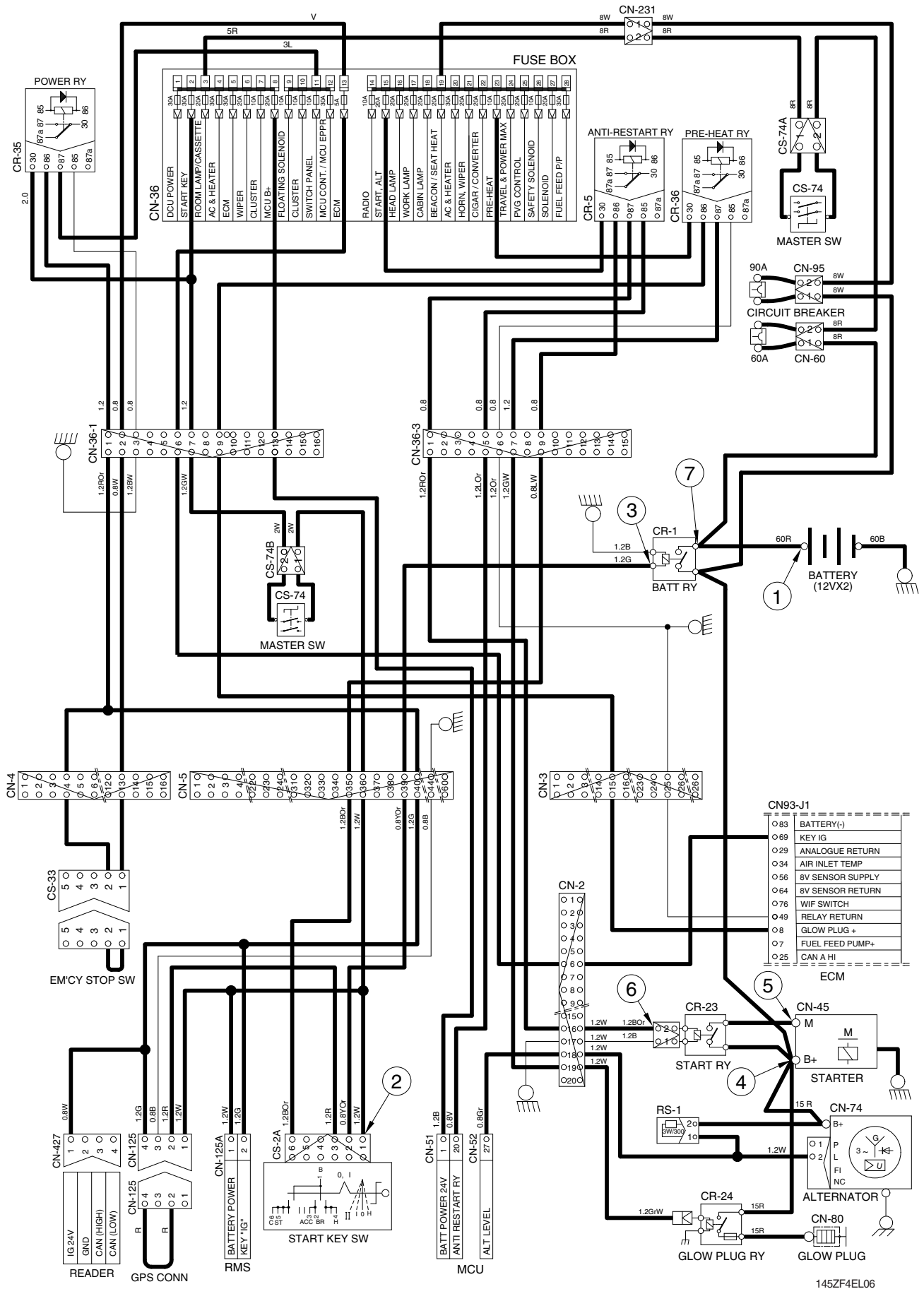

145ZF4EL06

3. CHARGING CIRCUIT

When the starter is activated and the engine is started, the operator releases the starting switch to the ON position.

Charging current generated by operating the alternator flows into the battery through the battery relay [CR-1].

The current also flows from the alternator to each electrical component and controller through the fuse box.

1) OPERATING FLOW

(1) Warning flow

Alternator [CN-74 (2)] → I/conn [CN-2 (18)] → MCU alternator level [CN-52 (27)]
 → Cluster charging warning lamp (via CAN interface)

(2) Charging flow

Alternator "B+" terminal → Starter motor [CN-45 (B+)]
 → Battery relay

- Battery (+) terminal
- Circuit breaker [CN-60] → Master switch [CS-74A] → I/conn [CN-231 (2)]
 → Fuse box [No. 1~8]
- Circuit breaker [CN-95] → I/conn [CN-231 (1)] → Fuse box [No. 14~28]

2) CHECK POINT

Engine	Start switch	Check point	Voltage
Run	ON	① - GND (battery voltage) ② - GND (battery relay) ③ - GND (alternator B ⁺ terminal) ④ - GND (alternator L terminal) ⑤ - GND (MCU)	20~25V

※ GND : Ground

CHARGING CIRCUIT

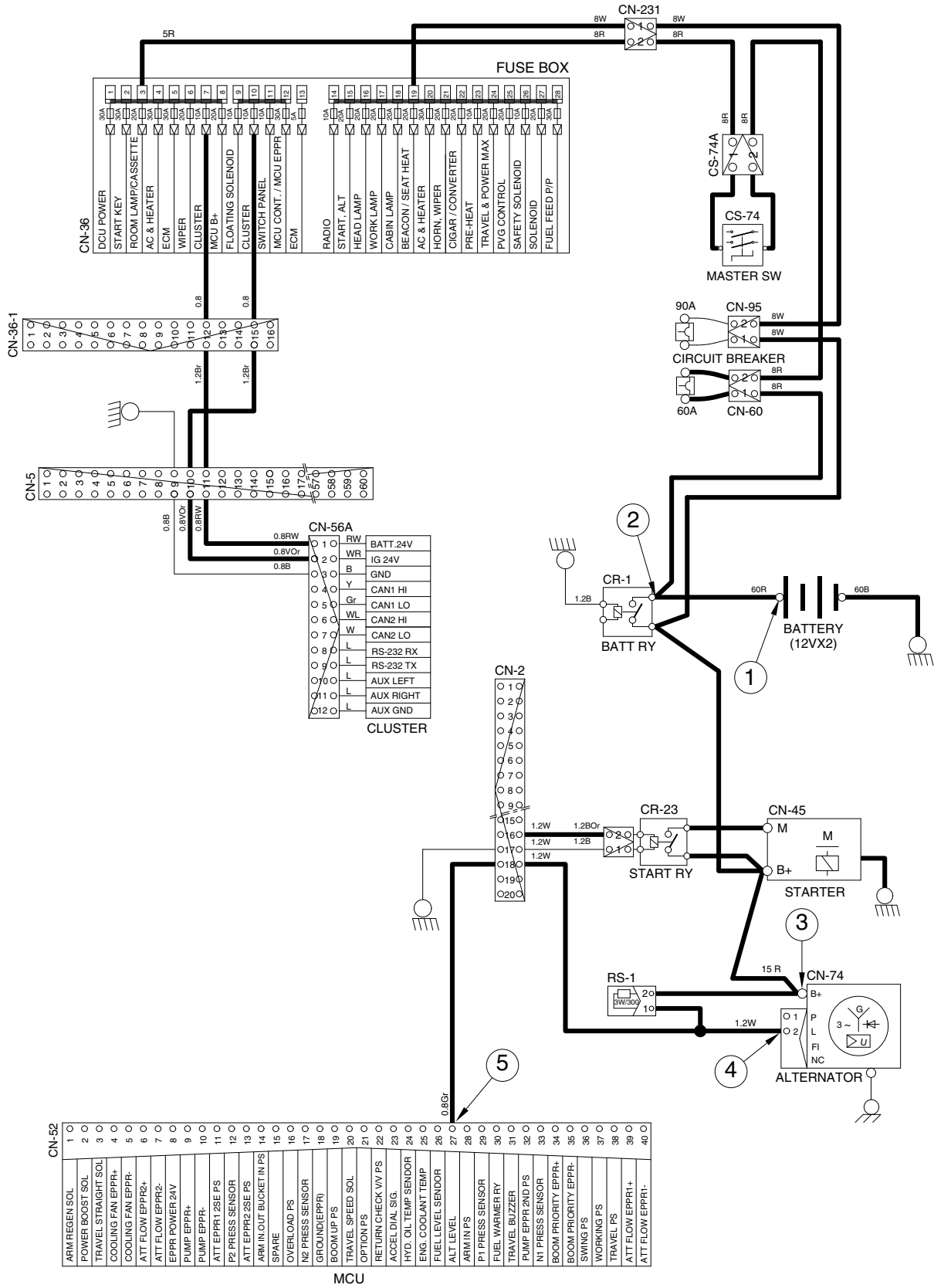

4. HEAD AND WORK LIGHT CIRCUIT

1) OPERATING FLOW

Fuse box (No.16) → I/conn [CN-36-2 (4)] → Head light relay [CR-13 (30, 86)]

Fuse box (No.17) → I/conn [CN-36-2 (5)] → Work light relay [CR-4 (30, 86)]

(1) Head light switch ON

Head light switch ON [CN-376 (13)] → Head light relay [CR-13 (85) → (87)]

→ Head light ON [CL-3 (2), CL-4 (2)]

→ I/conn [CN-7 (13)] → Accel dial LED ON [CN-267 (2)]

→ I/conn [CN-5 (60)] → Radio & USB player illumination ON [CN-27 (9)]

→ Remote controller illumination ON [CN-245A (9)]

→ USB & socket illumination ON [CN-246 (7)]

→ Cigar lighter [CL-2]

→ I/conn [CN-11 (8)] → AC & heater controller illumination ON (4)

(2) Work light switch ON

Work light switch ON [CN-376 (4)] → Work light relay [CR-4 (85) → (87)]

→ I/conn [CN-12 (2)] → Work light ON [CL-5 (2), CL-6 (2)]

2) CHECK POINT

Engine	Start switch	Check point	Voltage
STOP	ON	① - GND (fuse box) ② - GND (head light switch power output) ③ - GND (head light relay) ④ - GND (head light) ⑤ - GND (fuse box) ⑥ - GND (work light switch power output) ⑦ - GND (work light relay) ⑧ - GND (work light)	20~25V

※ GND : Ground

5. BEACON LAMP AND CAB LIGHT CIRCUIT

1) OPERATING FLOW

Fuse box (No.19) → I/conn [CN-36-1 (5)] → Beacon lamp relay [CR-85 (30, 86)]

Fuse box (No.18) → I/conn [CN-36-2 (6)] → Cab light relay [CR-9 (30, 86)]

(1) Beacon lamp switch ON

Beacon lamp switch ON [CN-376 (15)] → Beacon lamp relay [CR-85 (85)→ (87)]

→ I/conn [CN-5 (50)] → I/conn [CN-10 (10)] → Beacon lamp ON [CL-7]

(2) Cab light switch ON

Cab light switch ON [CN-376 (5)] → Cab lamp relay [CR-9 (85)→ (87)]

→ I/conn [CN-5 (34, 38)]

- I/conn [CN-10 (2)] → Cab light ON [CL-8 (2)]
- I/conn [CN-10 (12)] → Cab light ON [CL-9 (2)]
- I/conn [CN-10 (11)] → Cab light ON [CL-10 (2)]

2) CHECK POINT

Engine	Start switch	Check point	Voltage
STOP	ON	① - GND (fuse box) ② - GND (beacon lamp relay) ③ - GND (beacon lamp switch power output) ④ - GND (beacon lamp) ⑤ - GND (fuse box) ⑥ - GND (cab light relay) ⑦ - GND (cab light switch power output) ⑧ - GND (cab light)	20~25V

※ GND : Ground

BEACON LAMP AND CAB LIGHT CIRCUIT

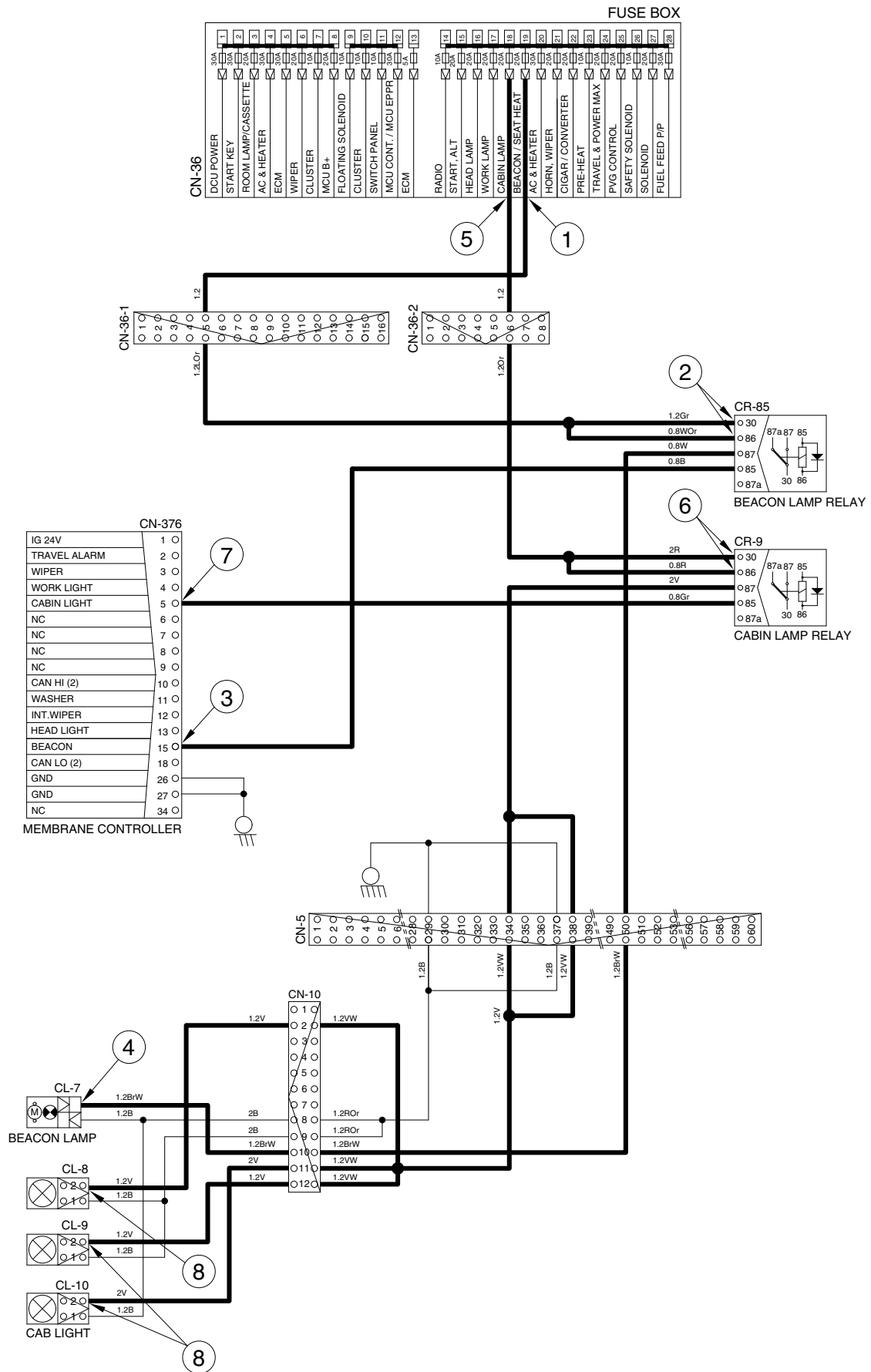

6. WIPER AND WASHER CIRCUIT

1) OPERATING FLOW

(1) Key switch ON

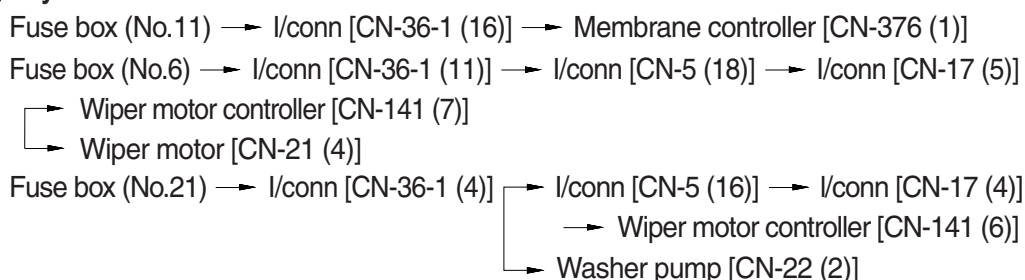

(2) Wiper switch ON (Intermittent)

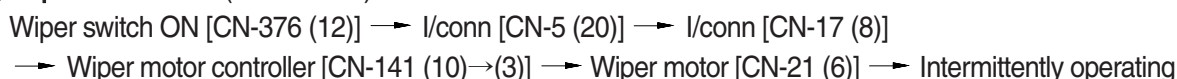

(3) Wiper switch ON (continual)

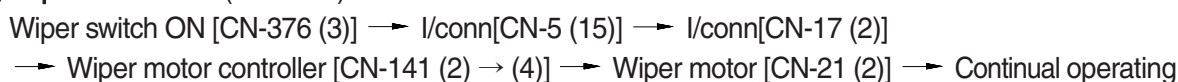

(4) Washer switch ON

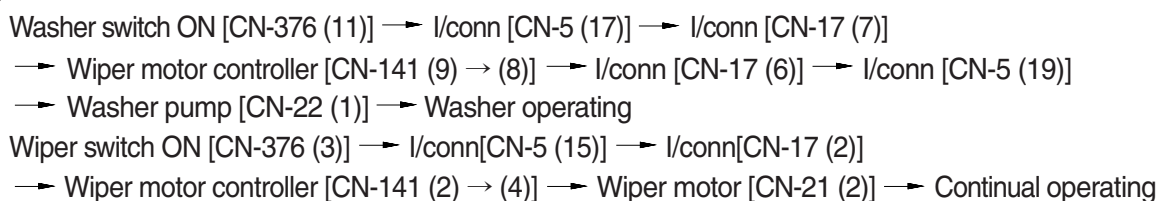

(5) Auto parking (when switch OFF)



3) CHECK POINT

Engine	Start switch	Check point	Voltage
STOP	ON	① - GND (fuse box)	20~25V
		② - GND (switch power input)	
		③ - GND (wiper power input)	
		④ - GND (switch power output)	0 ~ 5V
		⑤ - GND (wiper power input)	
		⑥ - GND (wiper power output)	24V
		⑦ - GND (wiper motor)	0 or 24V

※ GND : Ground

WIPER AND WASHER CIRCUIT

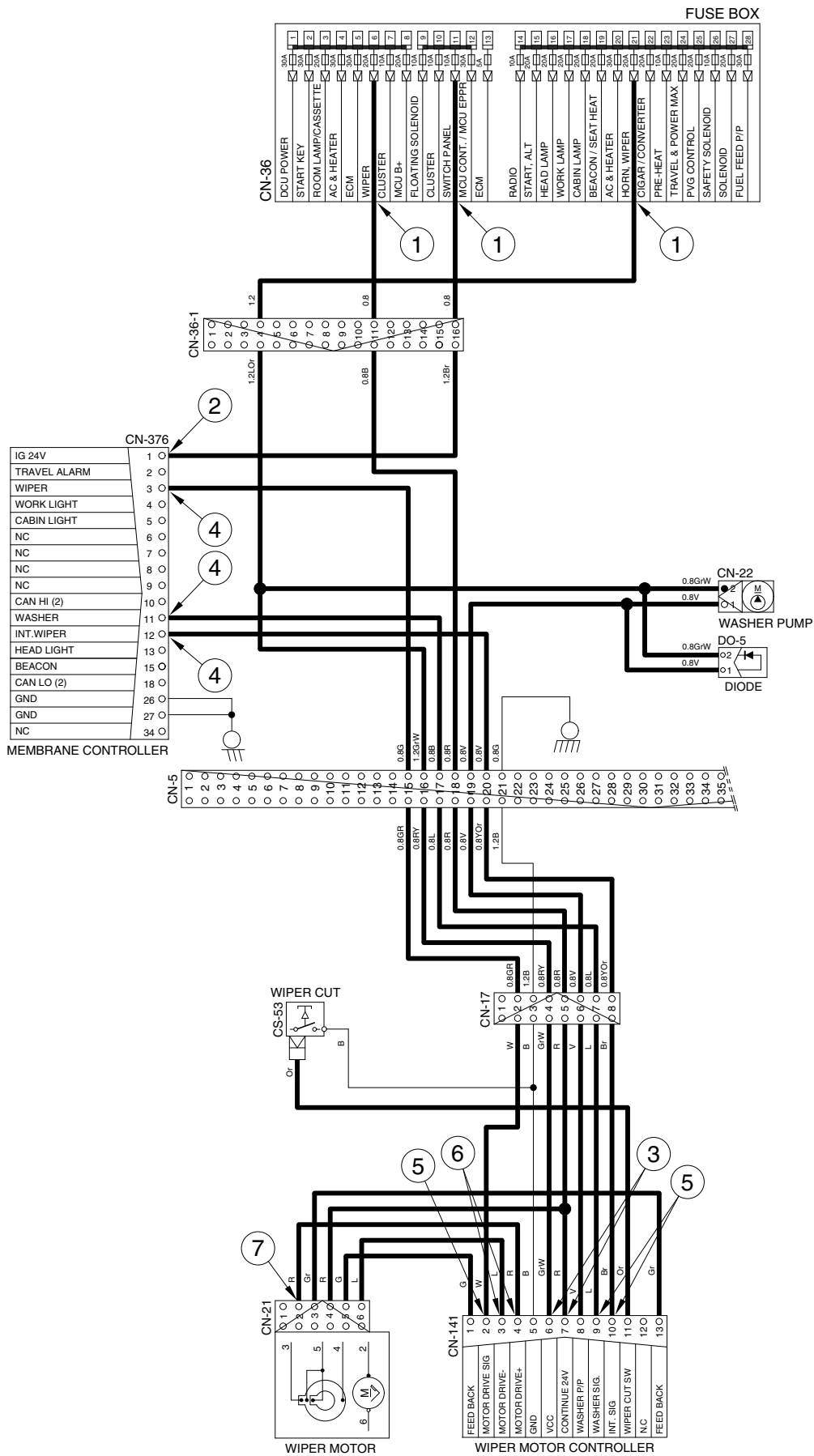

MONITORING CIRCUIT

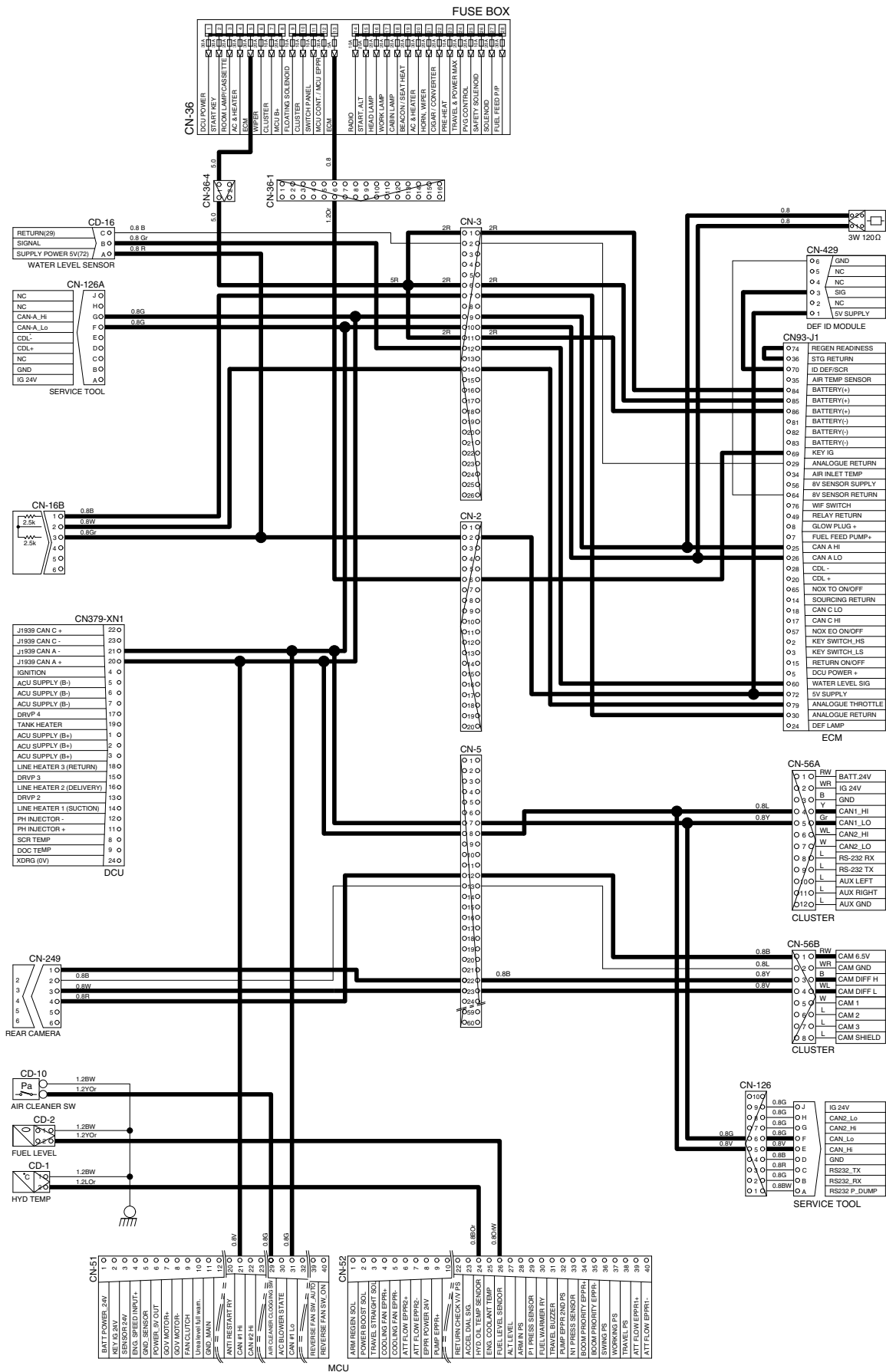

145ZF4EL12

ELECTRIC CIRCUIT FOR HYDRAULIC (1/2)

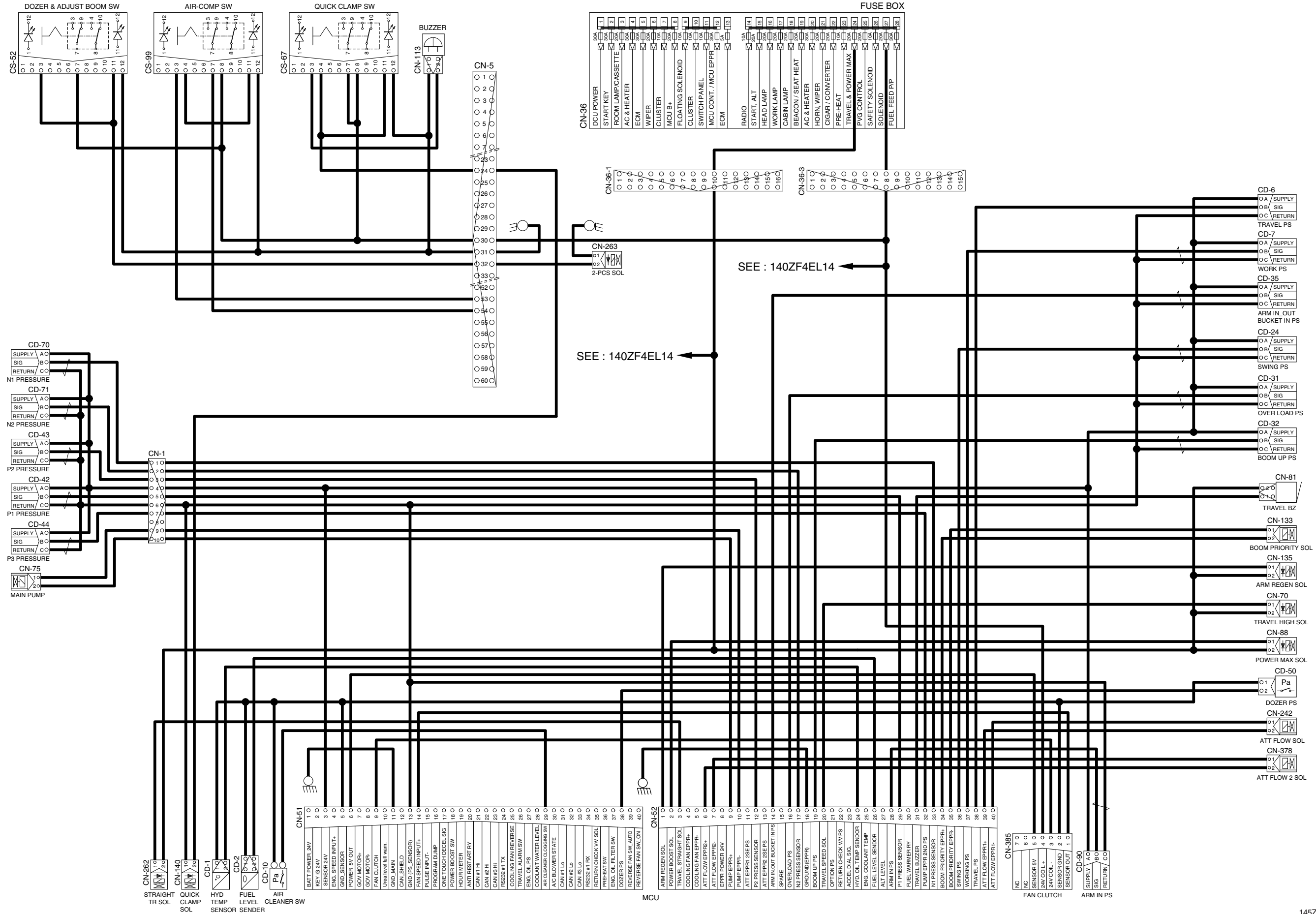

ELECTRIC CIRCUIT FOR HYDRAULIC (2/2)

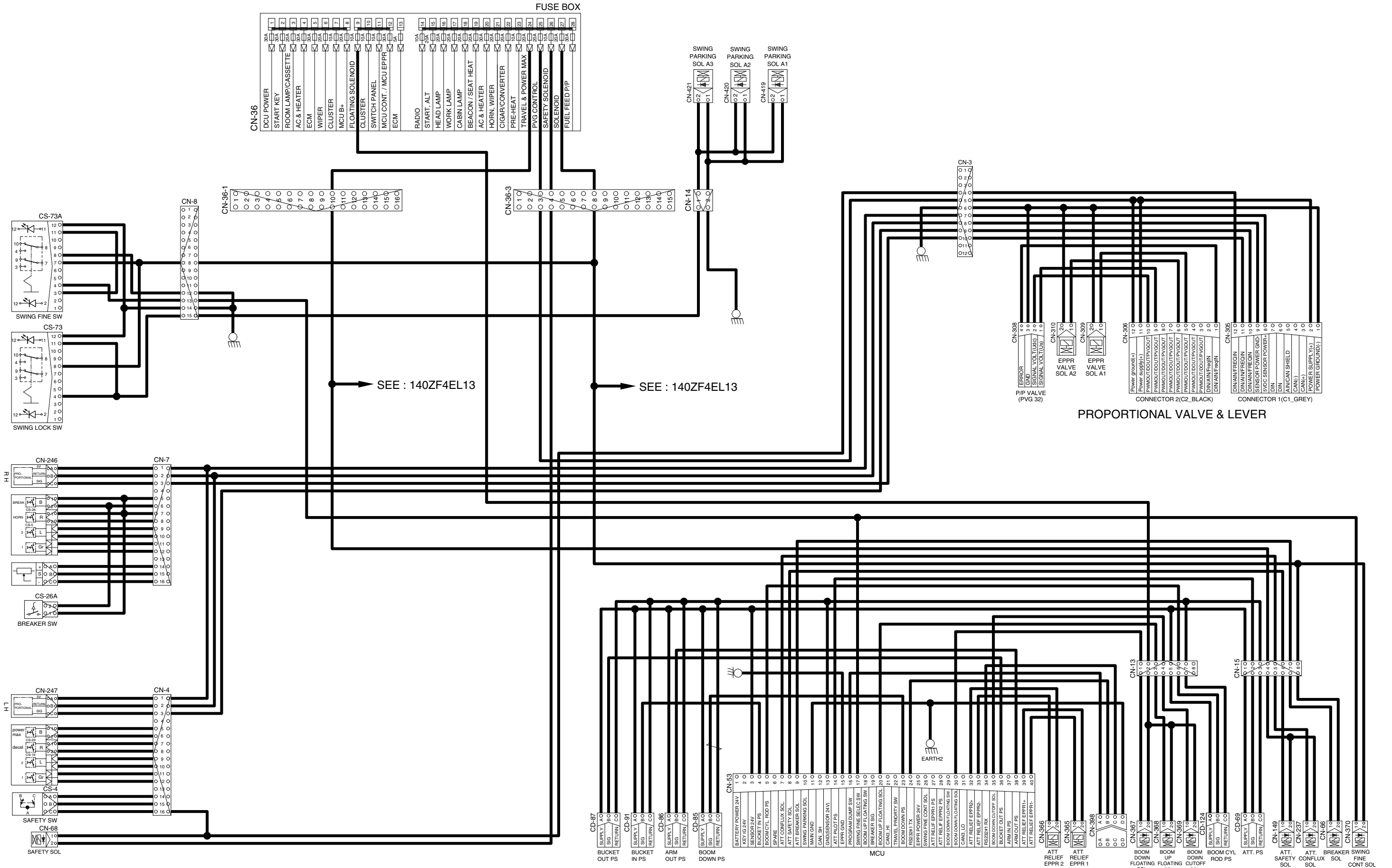

GROUP 3 ELECTRICAL COMPONENT SPECIFICATION

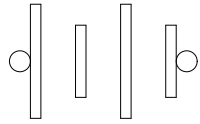
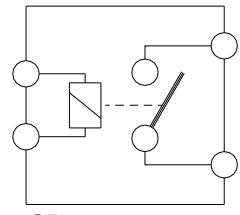
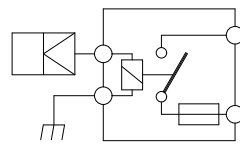
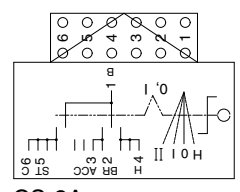
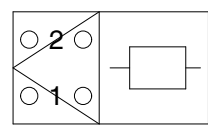

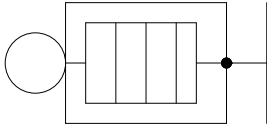
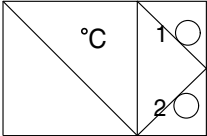
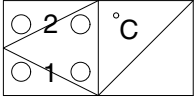
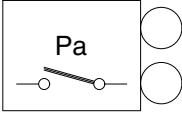
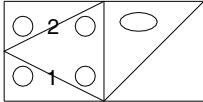
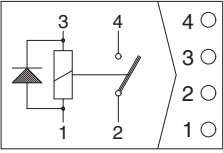
Part name	Symbol	Specifications	Check						
Battery		12V × 100Ah (2EA)	※ Check specific gravity 1.280 over : Over charged 1.280 ~ 1.250 : Normal 1.250 below : Recharging						
Battery relay	 <p style="text-align: center;">CR-1</p>	Rated load : 24V 100A (continuity) 1000A (30 seconds)	※ Check coil resistance(M4 to M4) Normal : About 50 Ω ※ Check contact Normal : ∞ Ω						
Glow plug relay	 <p style="text-align: center;">CR-24</p>	24V 200A	※ Check contact Normal : 0.942 Ω (For terminal 1-GND)						
Start key	 <p style="text-align: center;">CS-2A</p>	B-BR : 24V 1A B-ACC : 24V 10A B-C : 24V 40A	※ Check contact OFF : ∞ Ω (for each terminal) ON : 0 Ω (for terminal 1-3 and 1-2) START : 0 Ω (for terminal 1-6)						
Pressure sensor	<table border="1" style="margin-left: auto; margin-right: auto;"> <tr> <td>○ A</td> <td>SUPPLY</td> </tr> <tr> <td>○ B</td> <td>SIG</td> </tr> <tr> <td>○ C</td> <td>RETURN</td> </tr> </table> <p> CD-6 CD-7 CD-24 CD-31 CD-32 CD-35 CD-42 CD-43 CD-44 CD-69 CD-70 CD-71 CD-85 CD-86 CD-87 CD-90 CD-91 CD-124 </p>	○ A	SUPPLY	○ B	SIG	○ C	RETURN	8~30V	※ Check contact Normal : 0.1 Ω
○ A	SUPPLY								
○ B	SIG								
○ C	RETURN								
Resistor		3W 120 Ω	※ Check resistance 1-2 : 120 Ω						

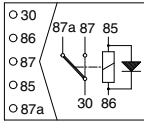
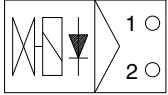
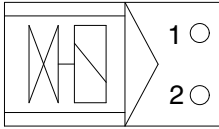
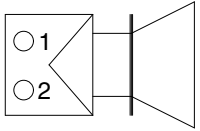
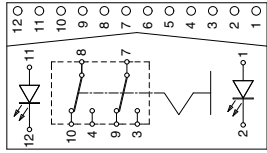
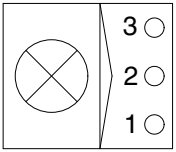
Part name	Symbol	Specifications	Check
Glow plug	 CN-80	24V 200A	※ Check resistance 0.25-0.12 Ω
Temperature sensor (hydraulic)	 CD-1	-	※ Check resistance 50°C : 804 Ω 80°C : 310 Ω 100°C : 180 Ω
Air inlet temperature sensor	 CD-98 CD-98A	-	-
Air cleaner pressure switch	 CD-10	N.O TYPE	※ Check contact High level : ∞ Ω Low level : 0 Ω
Fuel level sender	 CD-2	-	※ Check resistance Full : 50 Ω 6/12 : 350 Ω 11/12 : 100 Ω 5/12 : 400 Ω 10/12 : 150 Ω 4/12 : 450 Ω 9/12 : 200 Ω 3/12 : 500 Ω 8/12 : 250 Ω 2/12 : 550 Ω 7/12 : 300 Ω 1/12 : 600 Ω Empty warning : 700 Ω
Relay (air con blower)		24V 16A	※ Check resistance Normal : About 200 Ω (for terminal 1-3) ∞ Ω (for terminal 2-4)

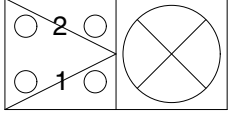
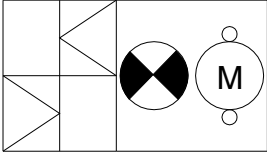
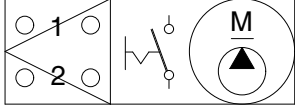
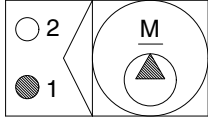
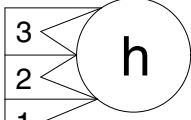
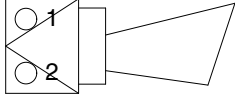
Part name	Symbol	Specifications	Check
Relay	 <p>CR-2 CR-4 CR-5 CR-7 CR-9 CR-13 CR-35 CR-36 CR-85 CR-95 CR-101</p>	24V 16A	※ Check resistance Normal : About 160 Ω (for terminal 85-86) 0 Ω (for terminal 30-87a) ∞ Ω (for terminal 30-87)
Solenoid valve	 <p>CN-66 CN-68 CN-70 CN-88 CN-135 CN-140 CN-149 CN-237 CN-262 CN-263 CN-367 CN-368 CN-369 CN-370 CN-419 CN-420 CN-421</p>	24V 1A	※ Check resistance Normal : 15~25 Ω (for terminal 1-2)
EPPR valve	 <p>CN-75 CN-133 CN-242 CN-309 CN-310 CN-365 CN-366 CN-378</p>	700mA	※ Check resistance Normal : 15~25 Ω (for terminal 1-2)
Speaker	 <p>CN-23(LH) CN-24(RH)</p>	20W 86±2dB	※ Check resistance Normal : A few Ω
Switch (locking type)	 <p>CS-52 CS-67 CS-73 CS-73A CS-99</p>	24V 1.5A	※ Check contact Normal ON : 0 Ω (for terminal 7-3) ∞ Ω (for terminal 7-9) OFF : ∞ Ω (for terminal 7-3) 0 Ω (for terminal 7-9)
Room lamp	 <p>CL-1</p>	24V 10W	※ Check disconnection Normal : 1.0 Ω ON : 0 Ω (For terminal 1-2) ∞ Ω (For terminal 1-3) OFF : ∞ Ω (For terminal 1-2) 0 Ω (For terminal 1-3)

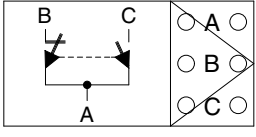
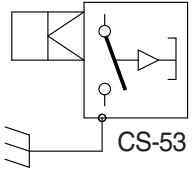
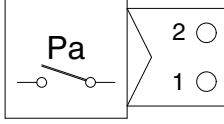
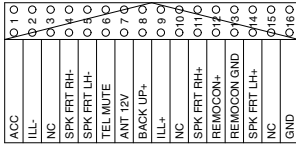
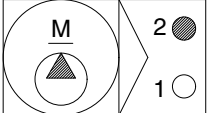
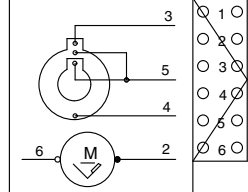
Part name	Symbol	Specifications	Check
Head lamp, Work lamp, Cab lamp	 <p>CL-3 CL-4 CL-5 CL-6 CL-8 CL-9 CL-10</p>	24V 65W (H3 Type)	※ Check disconnection Normal : 1.2 Ω
Beacon lamp	 <p>CL-7</p>	24V 70W (H1 Type) 2.4W (LED Type)	※ Check disconnection Normal : A few Ω
Fuel filler pump	 <p>CN-61</p>	24V 10A 35 l /min	※ Check resistance Normal : 1.0 Ω
Fuel feed pump	 <p>CN-145</p>	24V	-
Hour meter	 <p>CN-48</p>	16~32V	※ Check operation Supply power(24V) to terminal No.2 and connect terminal No.1 and ground
Horn	 <p>CN-20 CN-25</p>	22~28V 2A	※ Check operation Supply power(24V) to each terminal and connect ground.

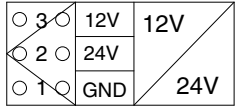
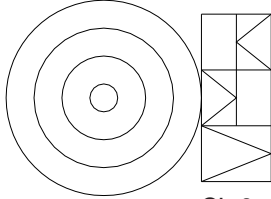
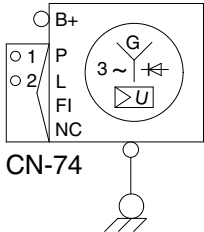
Part name	Symbol	Specifications	Check
Safety switch	 <p>CS-4</p>	24V 15A (N.C TYPE)	※ Check contact Normal : 1.0 Ω ON : 0 Ω (for terminal A-B) ∞ Ω (for terminal A-C) OFF : ∞ Ω (for terminal A-B) 0 Ω (for terminal A-C)
Wiper cut switch	 <p>CS-53</p>	24V (N.O TYPE)	※ Check contact Normal : 0 Ω (one pin to ground)
Receiver dryer	 <p>CN-29</p>	24V 2.5A (N.O TYPE)	※ Check contact Normal : ∞ Ω
Radio & USB player	 <p>CN-27</p>	24V 2A	※ Check voltage 20~25V (for terminal 1-3, 3-8)
Washer pump	 <p>CN-22</p>	24V 3.8A	※ Check contact Normal : 10.7 Ω (for terminal 1-2)
Wiper motor	 <p>CN-21</p>	24V 2A	※ Check disconnection Normal : 7 Ω (for terminal 2-6)

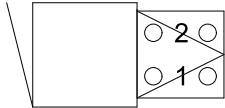
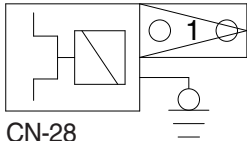
Part name	Symbol	Specifications	Check
DC/DC Converter	 <p>CN-138</p>	24V 3A	※ Check voltage 24V (for terminal 1-2) 12V (for terminal 1-3)
Cigar lighter	 <p>CL-2</p>	24V 5A 1.4W	※ Check coil resistance Normal : About 1M Ω ※ Check contact Normal : ∞ Ω Operating time : 5~15sec
Alternator	 <p>CN-74</p>	Delco Remy 24V 100A	※ Check contact Normal : 0 Ω (for terminal B ⁺ -2) Normal : 24~27.5V
Starter	 <p>CN-45</p>	24V 4.5kW	※ Check contact Normal : 0.1 Ω
Travel alarm	 <p>CN-81</p>	24V 0.5A	※ Check contact Normal : 5.2 Ω
Air conditioner compressor	 <p>CN-28</p>	24V 79W	※ Check contact Normal : 13.4 Ω

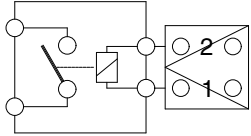
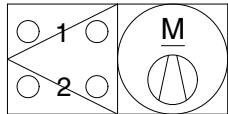
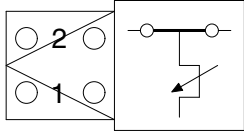
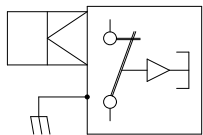
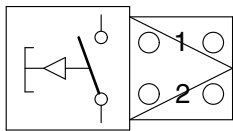
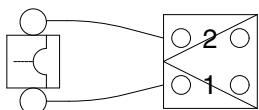
Part name	Symbol	Specifications	Check
Start relay	 <p>CR-23</p>	24V 300A	※ Check contact Normal : 0.94 Ω (for terminal 1-2)
Blower motor		24V 14A	※ Check resistance Normal : 2.5 Ω (for terminal 1-2)
Air conditioner duct sensor (switch)		1°C OFF 4°C ON	※ Check resistance Normal : 0 Ω (for terminal 1-2), the atmosphere temp : Over 4°C
Door switch	 <p>CS-1</p>	24V 2W	※ Check resistance Normal : About 5M Ω
Switch (power max, one touch decel, horn, breaker)	 <p>CS-5 CS-19 CS-26 CS-29</p>	24V 6A	※ Check resistance Normal : ∞ Ω
Circuit breaker	 <p>CN60 CN-95</p>	CN-60 : 60A CN-95 : 90A	※ Check disconnection Normal : 0 Ω (connect ring terminal and check resist between terminal 1 and 2)

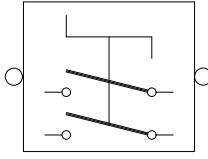
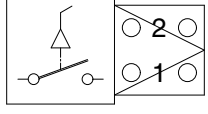
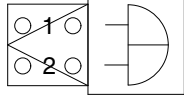
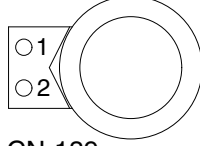
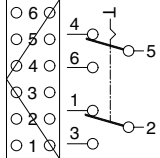
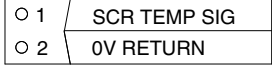
Part name	Symbol	Specifications	Check
Master switch	 <p>CS-74A CS-74B</p>	6-36V	※ Check disconnection Normal : 0.1 Ω
Breaker pedal switch	 <p>CS-26A</p>	-	-
Quick clamp buzzer	 <p>CN-113</p>	24V 80mA Min 65dB	-
12V Socket	 <p>CN-139</p>	12V 10A	-
Engine emergency stop switch	 <p>CS-33</p>	24V	※ Check contact Normal 0 Ω (for terminal 1-2)
SCR temperature sensor	 <p>CN-425</p>	-	-

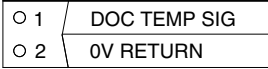
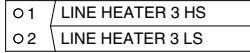
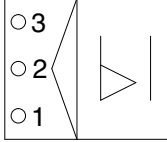
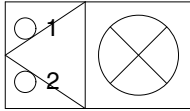
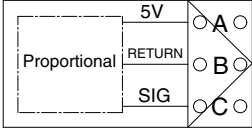
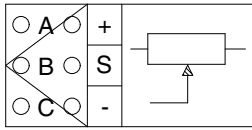
Part name	Symbol	Specifications	Check
DOC temperature sensor	 <p>CN-426</p>	-	-
DEF/AdBlue® line heater	 <p>CN-381 CN-382 CN-383</p>	-	-
WIF sensor	 <p>CD-45</p>	-	※ Check disconnection Normal : 68.8~4.94 Ω
DEF/AdBlue® fill up warning lamp (LED)	 <p>CL-40</p>	-	-
Proportional valve sensor	 <p>CN-246(RH) CN-247(LH)</p>	-	-
Accel dial	 <p>CN-142</p>	5V, 8mA	-

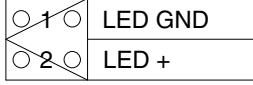
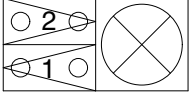
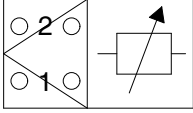
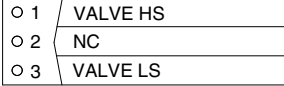
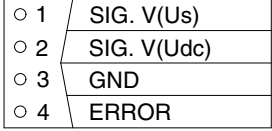
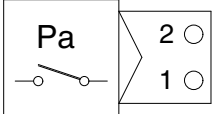
Part name	Symbol	Specifications	Check
Accel dial LED	 <p>CN-267</p>	24V	-
DEF/AdBlue® full lamp	 <p>CL-41</p>	-	-
Temperature sensor (A/C incar, A/C ambient, water)		-	-
Coolant diverter valve	 <p>CN-384</p>	-	-
Proportional valve sensor	 <p>CN-308</p>	-	-
Dozer act pressure switch	 <p>CD-50</p>	N.O type	※ Check resistance Normal : ∞ Ω (open)

Part name	Symbol	Specifications	Check												
Water level sensor	<table border="1"> <tr><td>○ C</td><td>RETURN(29)</td></tr> <tr><td>○ B</td><td>SIGNAL</td></tr> <tr><td>○ A</td><td>SUPPLY POWER 5V(72)</td></tr> </table> <p>CD-16</p>	○ C	RETURN(29)	○ B	SIGNAL	○ A	SUPPLY POWER 5V(72)	5V 12.5mA	-						
○ C	RETURN(29)														
○ B	SIGNAL														
○ A	SUPPLY POWER 5V(72)														
DEF/AdBlue® injector	<table border="1"> <tr><td>○ 1</td><td>UREA INJECTOR LS</td></tr> <tr><td>○ 2</td><td>UREA INJECTOR HS</td></tr> </table> <p>CN-424</p>	○ 1	UREA INJECTOR LS	○ 2	UREA INJECTOR HS	-	-								
○ 1	UREA INJECTOR LS														
○ 2	UREA INJECTOR HS														
Camera	<table border="1"> <tr><td>○ 1</td><td>LVDS POS</td></tr> <tr><td>○ 2</td><td>GND</td></tr> <tr><td>○ 3</td><td>LVDS NEG</td></tr> <tr><td>○ 4</td><td>POWER 24V</td></tr> <tr><td>○ 5</td><td>NC</td></tr> <tr><td>○ 6</td><td>ADJUST SIGNAL</td></tr> </table> <p>CN-249</p>	○ 1	LVDS POS	○ 2	GND	○ 3	LVDS NEG	○ 4	POWER 24V	○ 5	NC	○ 6	ADJUST SIGNAL	7V 100mA	-
○ 1	LVDS POS														
○ 2	GND														
○ 3	LVDS NEG														
○ 4	POWER 24V														
○ 5	NC														
○ 6	ADJUST SIGNAL														
NOx sensor (tail out, turbo out)	<table border="1"> <tr><td>○ 6</td><td>J1939 HI</td></tr> <tr><td>○ 5</td><td>J1939 LO</td></tr> <tr><td>○ 4</td><td>GND</td></tr> <tr><td>○ 3</td><td>ADDRESS SELEC</td></tr> <tr><td>○ 2</td><td>J1939-</td></tr> <tr><td>○ 1</td><td>BATT+</td></tr> </table> <p>CN-J7A CN-J7B</p>	○ 6	J1939 HI	○ 5	J1939 LO	○ 4	GND	○ 3	ADDRESS SELEC	○ 2	J1939-	○ 1	BATT+	-	-
○ 6	J1939 HI														
○ 5	J1939 LO														
○ 4	GND														
○ 3	ADDRESS SELEC														
○ 2	J1939-														
○ 1	BATT+														
Ammonia sensor	<table border="1"> <tr><td>○ 1</td><td>BATT +</td></tr> <tr><td>○ 2</td><td>J1939 CAN C +</td></tr> <tr><td>○ 3</td><td>J1939 CAN C -</td></tr> <tr><td>○ 4</td><td>GND</td></tr> </table> <p>CN-422</p>	○ 1	BATT +	○ 2	J1939 CAN C +	○ 3	J1939 CAN C -	○ 4	GND	-	-				
○ 1	BATT +														
○ 2	J1939 CAN C +														
○ 3	J1939 CAN C -														
○ 4	GND														
DEF/AdBlue® Id module	<table border="1"> <tr><td>○ 6</td><td>GND</td></tr> <tr><td>○ 5</td><td>NC</td></tr> <tr><td>○ 4</td><td>NC</td></tr> <tr><td>○ 3</td><td>SIG</td></tr> <tr><td>○ 2</td><td>NC</td></tr> <tr><td>○ 1</td><td>5V SUPPKY</td></tr> </table> <p>CN-429</p>	○ 6	GND	○ 5	NC	○ 4	NC	○ 3	SIG	○ 2	NC	○ 1	5V SUPPKY	-	-
○ 6	GND														
○ 5	NC														
○ 4	NC														
○ 3	SIG														
○ 2	NC														
○ 1	5V SUPPKY														

Part name	Symbol	Specifications	Check																								
Fan clutch	<table border="1" data-bbox="485 264 671 461"> <tr><td>○ 1</td><td>SENSOR OUT</td></tr> <tr><td>○ 2</td><td>SENSOR GND</td></tr> <tr><td>○ 3</td><td>24V COIL -</td></tr> <tr><td>○ 4</td><td>24V COIL +</td></tr> <tr><td>○ 5</td><td>SENSOR 5V</td></tr> <tr><td>○ 6</td><td>NC</td></tr> <tr><td>○ 7</td><td>NC</td></tr> </table> <p data-bbox="485 465 580 495">CN-385</p>	○ 1	SENSOR OUT	○ 2	SENSOR GND	○ 3	24V COIL -	○ 4	24V COIL +	○ 5	SENSOR 5V	○ 6	NC	○ 7	NC	-	-										
○ 1	SENSOR OUT																										
○ 2	SENSOR GND																										
○ 3	24V COIL -																										
○ 4	24V COIL +																										
○ 5	SENSOR 5V																										
○ 6	NC																										
○ 7	NC																										
PVG 32 controller	<table border="1" data-bbox="512 544 651 752"> <tr><td>○ 1</td><td>CAN HI</td></tr> <tr><td>○ 2</td><td>CAN LO</td></tr> <tr><td>○ 3</td><td>GND</td></tr> <tr><td>○ 4</td><td>SAFETY</td></tr> <tr><td>○ 5</td><td>KEY IG</td></tr> <tr><td>○ 6</td><td>GND</td></tr> <tr><td>○ 7</td><td>5V POWER</td></tr> <tr><td>○ 8</td><td>5V GND</td></tr> <tr><td>○ 9</td><td>ROTATE /LH</td></tr> <tr><td>○ 10</td><td>ROTATE /RH</td></tr> <tr><td>○ 11</td><td>NC</td></tr> <tr><td>○ 12</td><td>NC</td></tr> </table> <p data-bbox="512 757 592 786">CN-3A</p>	○ 1	CAN HI	○ 2	CAN LO	○ 3	GND	○ 4	SAFETY	○ 5	KEY IG	○ 6	GND	○ 7	5V POWER	○ 8	5V GND	○ 9	ROTATE /LH	○ 10	ROTATE /RH	○ 11	NC	○ 12	NC	-	-
○ 1	CAN HI																										
○ 2	CAN LO																										
○ 3	GND																										
○ 4	SAFETY																										
○ 5	KEY IG																										
○ 6	GND																										
○ 7	5V POWER																										
○ 8	5V GND																										
○ 9	ROTATE /LH																										
○ 10	ROTATE /RH																										
○ 11	NC																										
○ 12	NC																										

GROUP 4 CONNECTORS

1. CONNECTOR DESTINATION

Connector number	Type	No. of pin	Destination	Connector part No.	
				Female	Male
CN-1	AMP	10	l/conn (Frame harness-Pump PS harness)	S816-010002	S816-110002
CN-2	AMP	20	l/conn (Frame harness-Engine harness)	936777-2	936780-2
CN-3	-	26	l/conn (Frame harness-Engine harness)	1897009-2	1897013-2
CN-3A	AMP	12	PVG controller harness	174661-2	368537-1
CN-4	AMP	16	l/conn (Console harness LH-Frame harness)	368047-1	368050-1
CN-5	DEUTSCH	60	l/conn (Side harness RH-Frame harness)	DRB16-60SAE-L018	DRB14-60PAE-L018
CN-7	AMP	16	l/conn (Console harness RH-Frame harness)	368047-1	368050-1
CN-8	AMP	15	l/conn (Console harness LH-Frame harness)	2-85262-1	S816-112002
CN-10	TYCO	12	l/conn (Cab harness-Side harness RH)	368542-1	368507-1
CN-11	DEUTSCH	8	l/conn (Frame harness-Aircon harness)	DT06-8S	-
CN-12	DEUTSCH	2	l/conn (Frame harness-Boom wire harness)	DT06-2S-EP06	DT04-2P-E005
CN-13	AMP	8	l/conn (Frame harness-Boom floating harness)	174982-2	174984-2
CN-14	DEUTSCH	2	l/conn (Frame harness-Swing parking harness)	DT06-2S-EP06	DT04-2P
CN-15	AMP	8	l/conn (Frame harness-2 way harness)	174982-2	174984-2
CN-16	AMP	6	Emergency engine start & speed control	-	S816-106002
CN-16A	AMP	6	Emergency engine start & speed control	S816-006002	-
CN-16B	AMP	6	Emergency engine start & speed control	S816-006002	S816-106002
CN-17	DEUTSCH	8	l/conn (Side harness RH-Wiper harness)	DT06-8S-EP06	DT04-8P
CN-20	MOLEX	2	Horn	36812-0211	-
CN-21	AMP	6	Wiper motor	S810-006202	-
CN-22	KET	2	Washer tank	MG640605	-
CN-23	KET	2	Speaker-LH	MG610070	-
CN-24	KET	2	Speaker-RH	MG610070	-
CN-25	MOLEX	2	Horn	36812-0211	-
CN-27	KUM	16	Radio & USB player	PK145-16017	-
CN-27A	AMP	8	Radio & USB player	-	S816-108002
CN-28	KUM	1	Air conditioner compressor	NMWP01F-B	-
CN-29	KET	2	Receiver dryer	MG640795	-
CN-36-1	AMP	16	To fuse box	368047-1	-
CN-36-2	KET	8	To fuse box	MG610051	-
CN-36-3	-	26	To fuse box	1897009-2	-
CN-36-4	KET	2	To fuse box	MG610557-5	-
CN-45	RING-TERM	-	Starter motor B ⁺	S820-108000	-
CN-48	KET	1	Hour meter	2-520193-2	-

Connector number	Type	No. of pin	Destination	Connector part No.	
				Female	Male
CN-51	DEUTSCH	40	MCU	DRC26-40SA	-
CN-52	DEUTSCH	40	MCU	DRC26-40SB	-
CN-53	DEUTSCH	40	MCU (option)	DRC26-40SA	-
CN-56A	AMP	12	Cluster	-	174663-2
CN-56B	AMP	8	Cluster	-	174984-2
CN-60	YAZAKI	2	Circuit breaker	-	7122-4125-50
CN-61	DEUTSCH	2	Fuel filler pump	DT06-2S-EP06	-
CN-66	DEUTSCH	2	Breaker solenoid	DT06-2S-EP06	-
CN-68	DEUTSCH	2	Safety solenoid	DT06-2S-EP06	-
CN-70	DEUTSCH	2	Travel high solenoid	DT06-2S-EP06	-
CN-74	RING-TERM	2	Alternator "L" terminal	-	S820-108000
CN-75	AMP	2	Pump EPPR valve	S816-002002	-
CN-80	RING-TERM	-	Glow plug	S820-306000	-
CN-81	DEUTSCH	2	Travel buzzer	DT06-2S-EP06	DT04-2P-E005
CN-88	DEUTSCH	2	Power max solenoid	DT06-2S-EP06	-
CN-93-J1	DEUTSCH	86	ECM	DRCP28-86SA	-
CN-95	-	2	Circuit breaker	-	S813-130201
CN-113	KET	2	Buzzer	MG651205-5	-
CN-125	Econoseal J	4	GPS connector	S816-004002	S816-104002
CN-125A	DEUTSCH	12	RMS	DT06-12S-EP06	DT04-12P
CN-126	AMP	10	I/conn (Service tool-Frame harness)	S816-010002	S816-110002
CN-126A	-	9	Service tool	-	HD10-9-96P
CN-133	DEUTSCH	2	Boom priority solenoid	DT06-2S-EP06	-
CN-135	DEUTSCH	2	Arm regeneration solenoid	DT06-2S-EP06	-
CN-138	FASTEN	3	DC/DC Converter	S810-003202	-
CN-139	FASTEN	2	12V socket	172434-2	-
CN-140	DEUTSCH	2	Quick clamp solenoid	DT06-2S-EP06	DT04-2P-E005
CN-141	AMP	13	Wiper motor controller	172498-1	-
CN-142	DEUTSCH	3	Accel dial	DT06-3S-EP06	-
CN-144A	KET	20	Handsfree	MG610240	-
CN-144E	-	8	Handsfree	175964-2	-
CN-145	DEUTSCH	2	Fuel filler pump	DT06-2S-EP06	-
CN-149	DEUTSCH	2	Attach safety solenoid	DT06-2S-EP06	-
CN-156	-	2	Air seat heat	-	S816-102002
CN-157	AMP	1	Antena power	S822-014002	-
CN-231	-	2	To fuse box	S813-030201	-
CN-237	DEUTSCH	2	Attach confluc solenoid	DT06-2S-EP06	-
CN-242	DEUTSCH	2	Attach EPPR 1	DT06-2S-EP06	-

Connector number	Type	No. of pin	Destination	Connector part No.	
				Female	Male
CN-245	FCI	2	PTC power	-	-
CN-245A	AMP	12	Remote controller assy	368542-1	-
CN-245E	AMP	12	Remote controller assy	174045-2	-
CN-246	AMP	12	USB & socket assy	174045-2	-
CN-246	DEUTSCH	3	Proportional valve-RH	DT06-3S	DT04-3P
CN-247	DEUTSCH	3	Proportional valve-LH	DT06-3S	DT04-3P
CN-249	DEUTSCH	6	Rear view camera	-	DT04-6P
CN-259	AMP	6	Camera	S816-006002	S816-106002
CN-262	DEUTSCH	2	Straight travel solenoid	DT06-2S-EP06	DT04-2P-E005
CN-263	DEUTSCH	2	2 Piece solenoid	DT06-2S-EP06	DT04-2P-E005
CN-267	AMP	2	Accel dial LED	S816-002002	-
CN-305	DEUTSCH	12	To PVG controller	DTM06-12SA	-
CN-306	DEUTSCH	12	To PVG controller	DTM06-12SB	-
CN-307	DEUTSCH	3	Proportional-Service tool	DT06-3S-EP06	DT04-3P-E005
CN-308	AMP	4	Proportional-PVG32	2-967059-1	-
CN-309	DEUTSCH	2	Proportional-EPPR valve A1	DT06-2S-EP06	-
CN-310	DEUTSCH	2	Proportional-EPPR valve A2	DT06-2S-EP06	-
CN-365	DEUTSCH	2	Attach relief EPPR valve 1	DT06-2S-EP06	-
CN-366	DEUTSCH	2	Attach relief EPPR valve 2	DT06-2S-EP06	DT04-2P-E005
CN-367	DEUTSCH	2	Boom down floating solenoid	DT06-2S-E005	-
CN-368	DEUTSCH	2	Boom up floating solenoid	DT06-2S-E005	-
CN-369	DEUTSCH	2	Boom down cut off solenoid	DT06-2S-E005	-
CN-370	DEUTSCH	2	Swing fine control solenoid	DT06-2S-EP06	DT04-2P-E005
CN-376	AMP	34	Membrane controller	4-1437290-1	-
CN-378	DEUTSCH	2	Attach EPPR 2	DT06-2S-EP06	-
CN-379-XN1	DEUTSCH	24	DCU module	HDP24-24-31ST	-
CN-381	DEUTSCH	2	DEF/AdBlue® line heater 2	DT06-2S-EP06	-
CN-382	DEUTSCH	2	DEF/AdBlue® line heater 1	DT06-2S-EP06	-
CN-383	DEUTSCH	2	DEF/AdBlue® line heater 3	DT06-2S-EP06	-
CN-384	AMP	3	Coolant diverter valve	1-1418448-1	-
CN-385	-	7	Fan clutch	965570	-
CN-398	DEUTSCH	4	Service tool	DT06-4S	-
CN-398	DEUTSCH	4	Service tool	DT06-4S	DT04-4P
CN-419	DEUTSCH	2	Swing parking solenoid-A1	DT06-2S-EP06	-
CN-420	DEUTSCH	2	Swing parking solenoid-A2	DT06-2S-EP06	-
CN-421	DEUTSCH	2	Swing parking solenoid-A3	DT06-2S-EP06	-
CN-422	AMP	4	Ammonia sensor	1-1418390-1	-

Connector number	Type	No. of pin	Destination	Connector part No.	
				Female	Male
CN-423	DEUTSCH	4	Tank header unit	DT06-4S	-
CN-424	AMP	2	DEF/AdBlue® injector temperature sensor	2098557-1	-
CN-425	AMP	2	SCR temperature sensor	282080-1	-
CN-426	AMP	2	DOC temperature sensor	282080-1	-
CN-427	MOLEX	4	Reader-RMS	039012040	026013096
		12		5557-12R	5559-12P
CN-429	AMP	6	DEF/AdBlue® ID module sensor	776433-3	-
CN-J7A	AMP	6	NOx sensor (tail)	776433-2	-
CN-J7B	AMP	6	NOx sensor (turbo out)	776433-1	-
· Relay					
CR-1	RING-TERM	-	Battery relay	ST710289-2	-
CR-2	-	5	Horn relay	-	-
CR-4	-	5	Work lamp relay	8JA 003 526-001	-
CR-5	-	5	Anti restart relay	-	-
CR-7	-	5	Aircon compressor relay	-	-
CR-9	-	5	Cabin lamp relay	8JA 003 526-001	-
CR-13	-	5	Head lamp relay	8JA 003 526-001	-
CR-23	KET	2	Start relay	-	MG640322
CR-24	RING TERM	1	Preheat relay	S822-014000	-
CR-35	-	5	Power relay	-	-
CR-36	-	5	Preheat relay	-	-
CR-85	-	5	Beacon lamp relay	8JA 003 526-001	-
CR-95	-	5	Feed pump relay	8JA 003 526-001	-
CR-101	-	5	DCU relay	8JA 003 526-001	-
· Switch					
CS-1	SHUR	1	Door switch	S822-014002	-
CS-2A	WP	6	Start key switch	S814-006100	-
CS-2B	DEUTSCH	3	Start button	DT06-3S-EP06	DT04-3P-E005
CS-4	AMP	3	Safety switch	S816-003002	-
CS-5	DEUTSCH	2	Horn switch	-	DT04-2P-E005
CS-19	DEUTSCH	2	One touch decel switch	-	DT04-2P-E005
CS-26	DEUTSCH	2	Breaker switch	DT06-2S-EP06	-
CS-26A	AMP	2	Breaker pedal switch	S816-002002	S816-102002
CS-29	DEUTSCH	2	Power max switch	DT06-2S-EP06	-
CS-33	AMP	6	Emergency engine stop switch	S816-006002	S816-106002
CS-52	SWF	12	Adjust & dozer switch	SWF589790	-
CS-53	AMP	1	Wiper cut switch	S822-014002	-
CS-67	SWF	12	Quick clamp switch	SWF589790	-
CS-73	SWF	12	Swing lock switch	SWF589790	-

Connector number	Type	No. of pin	Destination	Connector part No.	
				Female	Male
CS-73A	SWF	12	Swing fine switch	SWF589790	-
CS-74A	AMP	2	Master switch	S813-030201	-
CS-74B	AMP	2	Master switch	S813-030201	-
CS-83	SWF	12	Spare switch	SWF589790	-
CS-99	SWF	12	Air compressor switch	SWF589790	-
CS-100	SWF	12	Spare switch	SWF589790	-
CS-107	SWF	12	Travel straight switch	SWF589790	-
CS-111	SWF	12	Boom floating switch	SWF589790	-
· Light					
CL-1	KET	3	Room lamp	MG651032	-
CL-2	AMP	1	Cigar lighter	S822-014002	S822-114002
CL-3	DEUTSCH	2	Head lamp-LH	DT06-2S-EP06	-
CL-4	DEUTSCH	2	Head lamp-RH	DT06-2S-EP06	-
CL-5	DEUTSCH	2	Work lamp-LH	DT06-2S-EP06	-
CL-6	DEUTSCH	2	Work lamp-RH	DT06-2S-EP06	-
CL-7	SHUR	1	Beacon lamp	S822-014002	S822-114002
CL-8	DEUTSCH	2	Cab light-LH	DT06-2S-EP06	DT04-2P
CL-9	DEUTSCH	2	Cab light-RH	DT06-2S-EP06	DT04-2P
CL-10	DEUTSCH	2	Cab light-rear	DT06-2S-EP06	DT04-2P
CL-40	DEUTSCH	2	DEF/AdBlue® purging lamp	DT06-2S-EP06	DT04-2P
CL-41	AMP	1	DEF/AdBlue® F/warning lamp	S822-010400	S822-101400
· Sensor, sendor					
CD-1	AMP	2	Hydraulic oil temp sender	85202-1	-
CD-2	DEUTSCH	2	Fuel sender	DT06-2S-EP06	-
CD-6	DEUTSCH	3	Travel pressure switch	DT06-3S-EP06	-
CD-7	DEUTSCH	3	Working pressure switch	DT06-3S-EP06	-
CD-10	AMP	2	Air cleaner switch	85202-1	-
CD-16	DELPHI	3	Water level sensor	12110293	-
CD-24	DEUTSCH	3	Swing pressure sensor	DT06-3S-EP06	-
CD-31	DEUTSCH	3	Overload pressure sensor	DT06-3S-EP06	DT04-3P-E004
CD-32	DEUTSCH	3	Boom up pressure sensor	DT06-3S-EP06	-
CD-35	DEUTSCH	3	Arm in/out pressure sensor	DT06-3S-EP06	-
CD-42	DEUTSCH	3	Pump pressure sensor 1	DT06-3S-EP06	-
CD-43	DEUTSCH	3	Pump pressure sensor 2	DT06-3S-EP06	-
CD-44	DEUTSCH	3	Pump pressure sensor 3	DT06-3S-EP06	-
CD-45	AMP	3	WIF sensor	776429-3	-
CD-50	KET	2	Dozer pressure sensor	MG640795	-
CD-69	DEUTSCH	3	Attach pressure sensor	DT06-3S-EP06	-

Connector number	Type	No. of pin	Destination	Connector part No.	
				Female	Male
CD-70	DEUTSCH	3	N1 pressure sensor	DT06-3S-EP06	-
CD-71	DEUTSCH	3	N2 pressure sensor	DT06-3S-EP06	-
CD-85	DEUTSCH	3	Boom down sensor	DT06-3S-EP06	-
CD-86	DEUTSCH	3	Arm out pressure sensor	DT06-3S-E005	-
CD-87	DEUTSCH	3	Bucket out pressure sensor	DT06-3S-E005	-
CD-90	DEUTSCH	3	Arm in pressure sensor	DT06-3S-EP06	-
CD-91	DEUTSCH	3	Bucket in pressure sensor	DT06-3S-E005	-
CD-98	AMP	2	Air inlet temperature sensor	776427-1	-
CD-98A	AMP	2	Air intake temperature sensor	776427-1	-
CD-124	DEUTSCH	3	Boom cylinder rod pressure snensor	DT06-3S-E005	-

2. CONNECTION TABLE FOR CONNECTORS

1) PA TYPE CONNECTOR

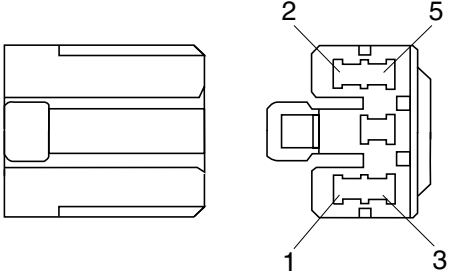
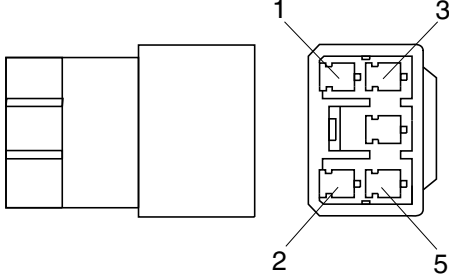
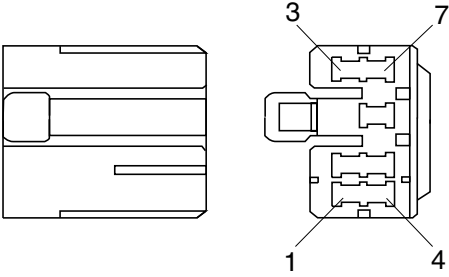
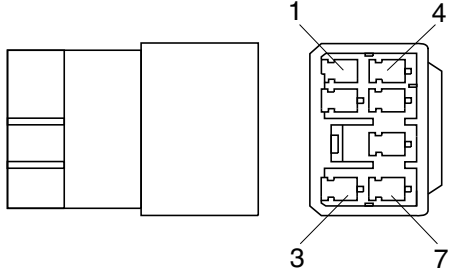
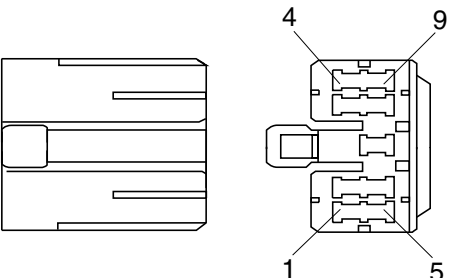
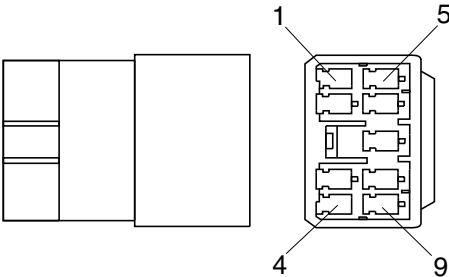
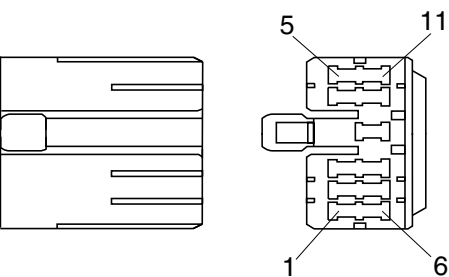
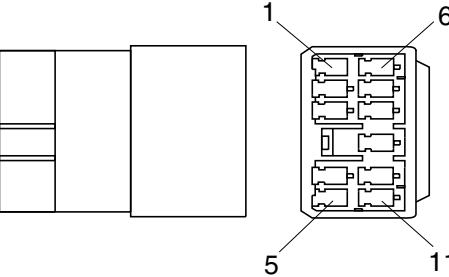
No. of pin	Receptacle connector (female)	Plug connector (male)
5	 <p style="text-align: center;">S811-005002</p>	 <p style="text-align: center;">S811-105002</p>
7	 <p style="text-align: center;">S811-007002</p>	 <p style="text-align: center;">S811-107002</p>
9	 <p style="text-align: center;">S811-009002</p>	 <p style="text-align: center;">3S811-109002</p>
11	 <p style="text-align: center;">S811-011002</p>	 <p style="text-align: center;">S811-111002</p>

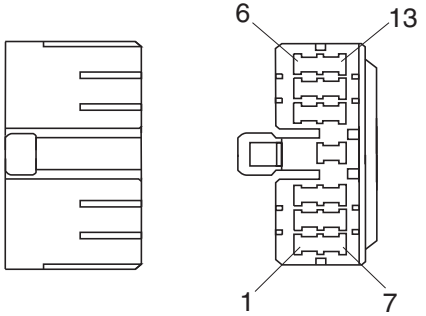
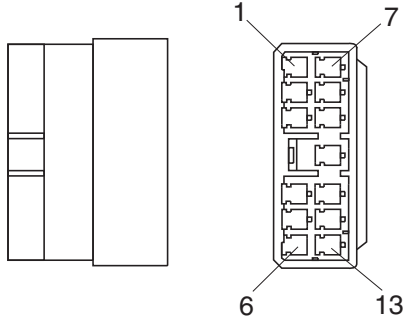
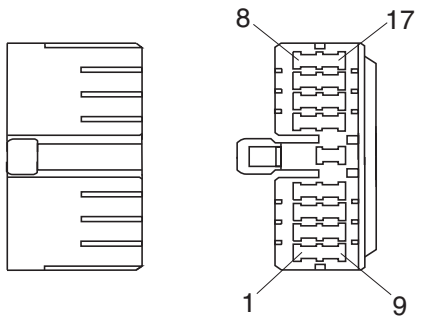
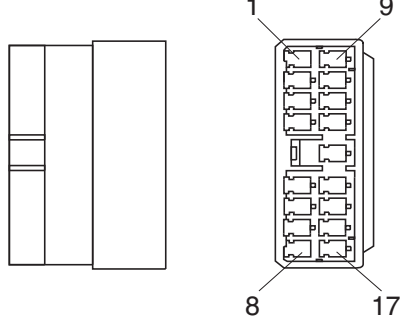
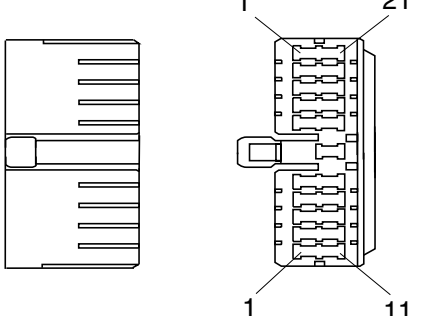
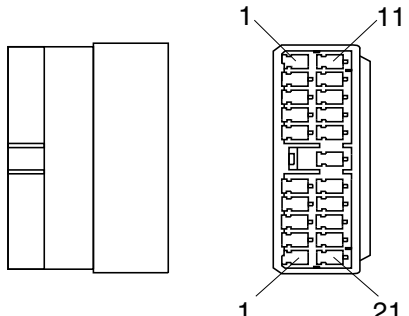
No. of pin	Receptacle connector (female)	Plug connector (male)
13	 <p style="text-align: center;">S811-013002</p>	 <p style="text-align: center;">S811-113002</p>
17	 <p style="text-align: center;">S811-017002</p>	 <p style="text-align: center;">S811-117002</p>
21	 <p style="text-align: center;">S811-021002</p>	 <p style="text-align: center;">S811-121002</p>

2) J TYPE CONNECTOR

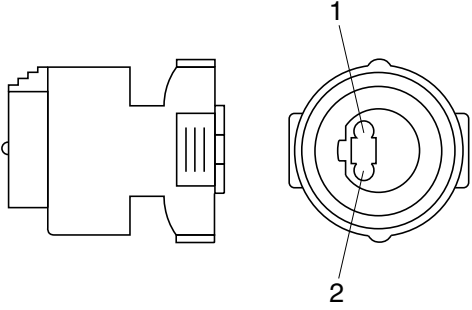
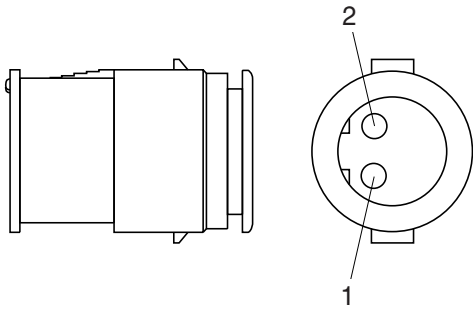
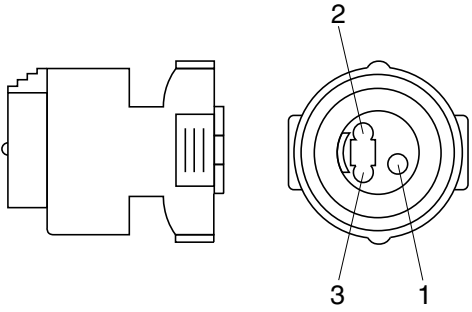
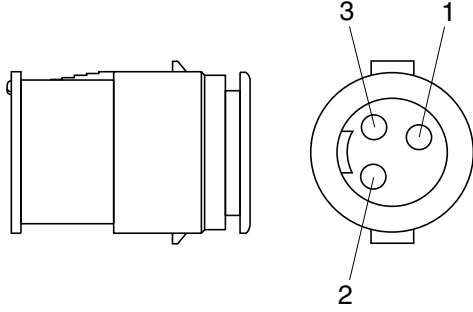
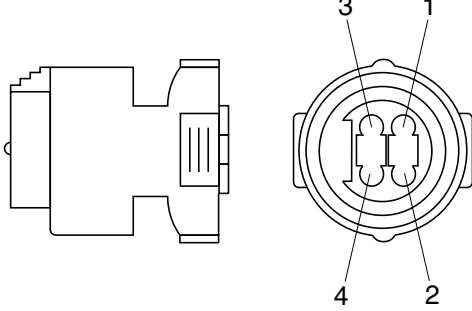
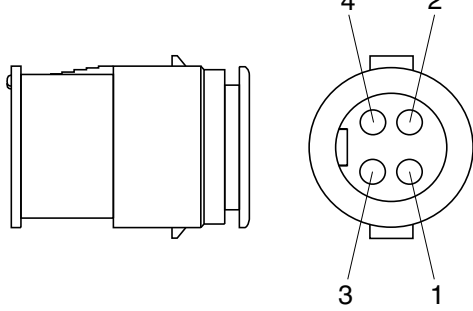
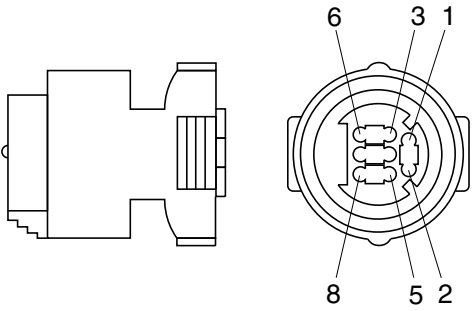
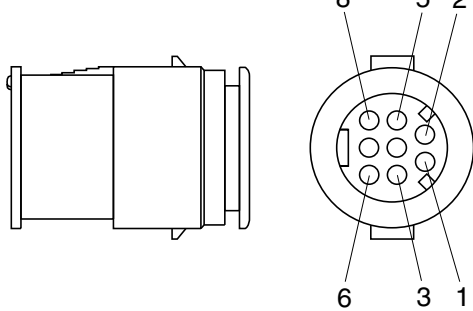
No. of pin	Receptacle connector (female)	Plug connector (male)
2	 <p style="text-align: center;">S816-002001</p>	 <p style="text-align: center;">S816-102001</p>
3	 <p style="text-align: center;">S816-003001</p>	 <p style="text-align: center;">S816-103001</p>
4	 <p style="text-align: center;">S816-004001</p>	 <p style="text-align: center;">S816-104001</p>
8	 <p style="text-align: center;">S816-008001</p>	 <p style="text-align: center;">S816-108001</p>

3) SWP TYPE CONNECTOR

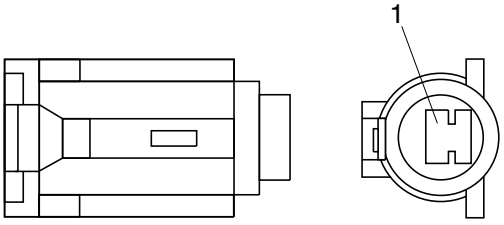
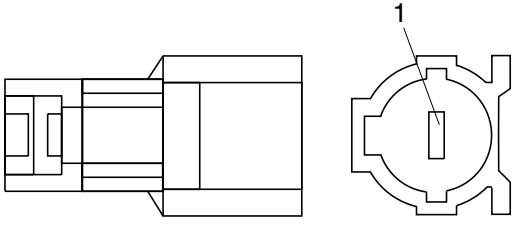
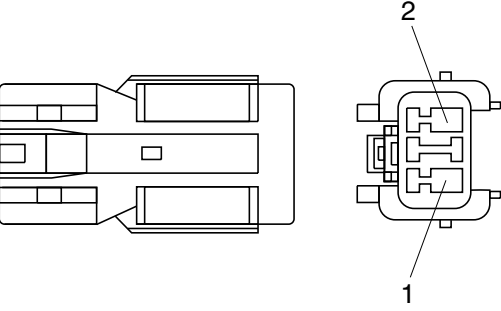
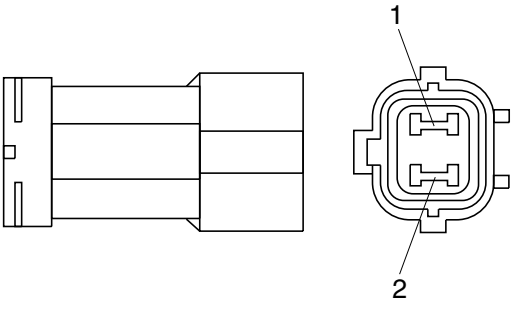
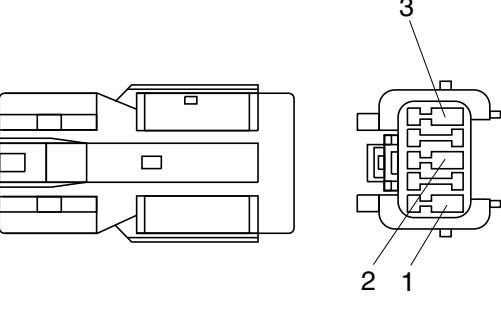
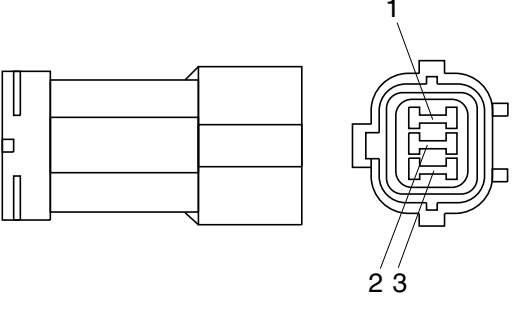
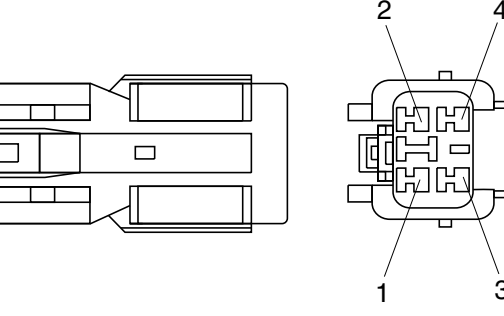
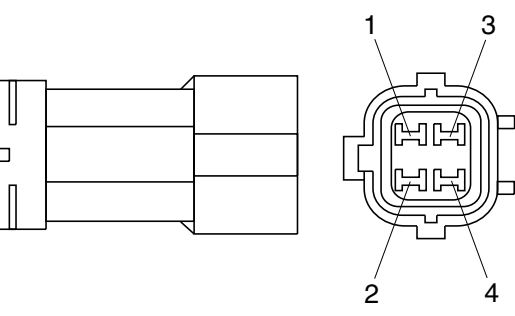
No. of pin	Receptacle connector (female)	Plug connector (male)
1	 <p data-bbox="687 680 836 712">S814-001000</p>	 <p data-bbox="1241 680 1390 712">S814-101000</p>
2	 <p data-bbox="687 1084 836 1115">S814-002000</p>	 <p data-bbox="1241 1084 1390 1115">S814-102000</p>
3	 <p data-bbox="687 1494 836 1525">S814-003000</p>	 <p data-bbox="1241 1494 1390 1525">S814-103000</p>
4	 <p data-bbox="687 1890 836 1921">S814-004000</p>	 <p data-bbox="1241 1890 1390 1921">S814-104000</p>

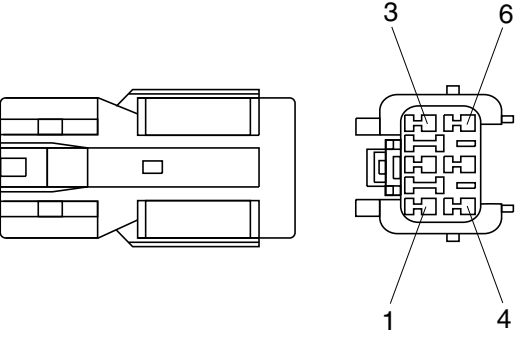
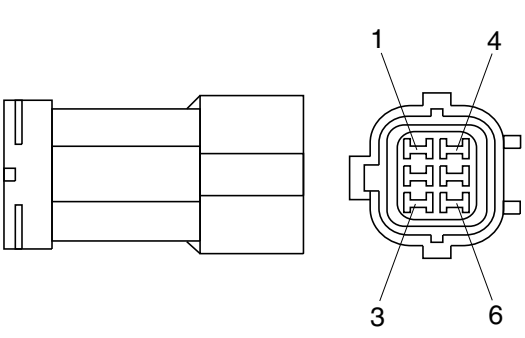
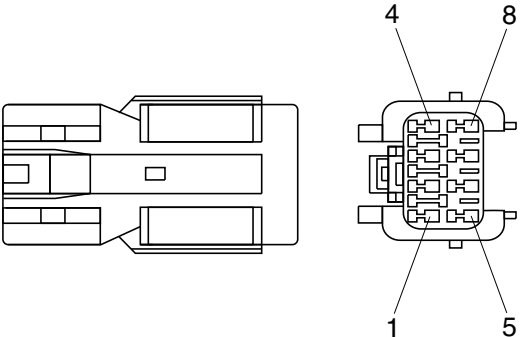
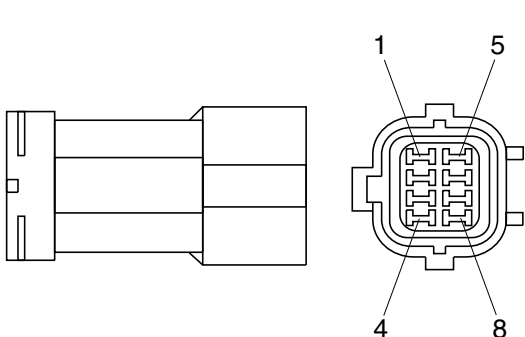
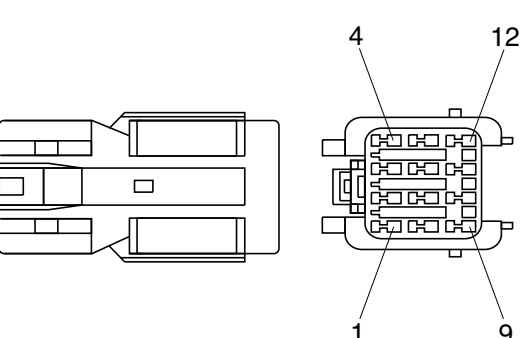
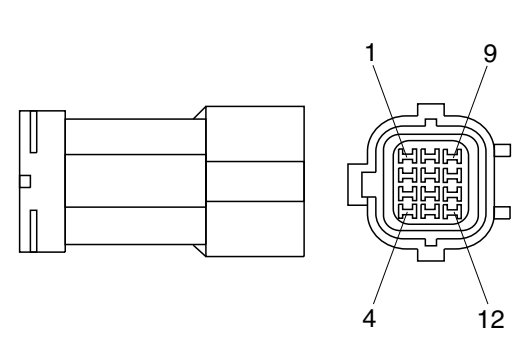
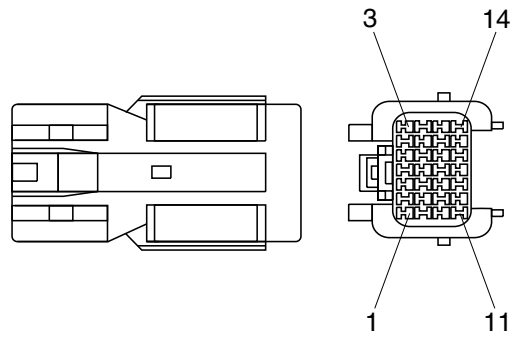
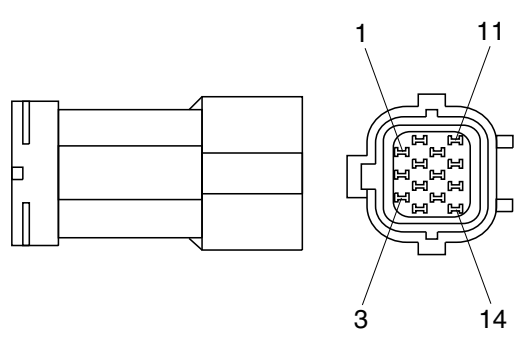
No. of pin	Receptacle connector (female)	Plug connector (male)
6	 <p data-bbox="686 638 837 672">S814-006000</p>	 <p data-bbox="1244 638 1396 672">S814-106000</p>
8	 <p data-bbox="686 1041 837 1075">S814-008000</p>	 <p data-bbox="1244 1041 1396 1075">S814-108000</p>
12	 <p data-bbox="686 1449 837 1482">S814-012000</p>	 <p data-bbox="1244 1449 1396 1482">S814-112000</p>
14	 <p data-bbox="686 1856 837 1890">S814-014000</p>	 <p data-bbox="1244 1856 1396 1890">S814-114000</p>

4) CN TYPE CONNECTOR

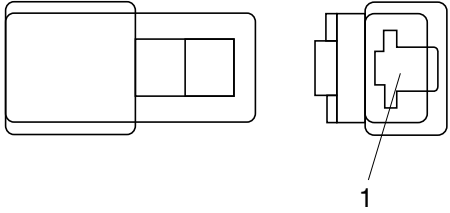
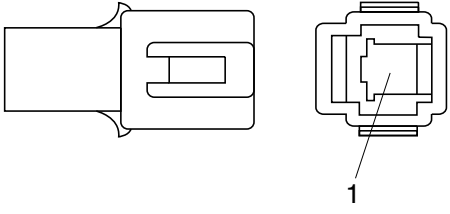
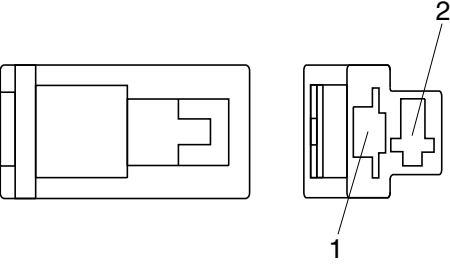
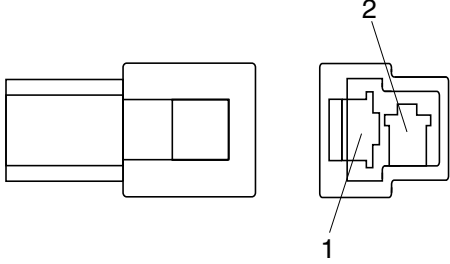
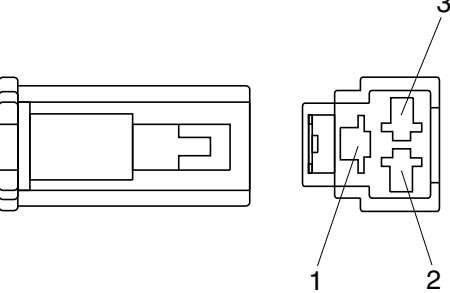
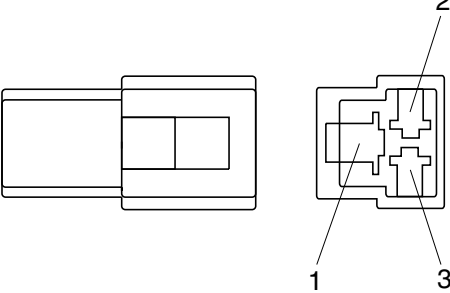
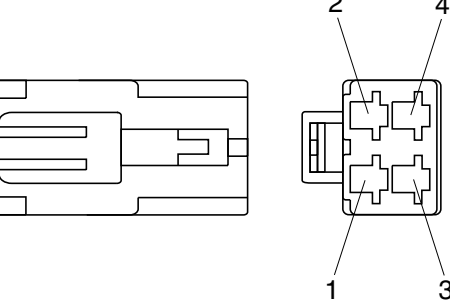
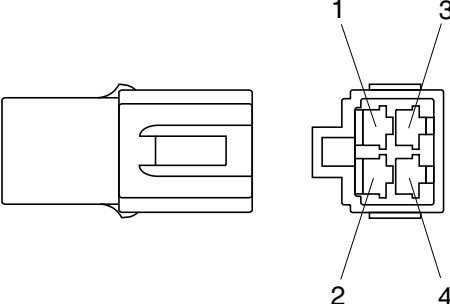
No. of pin	Receptacle connector (female)	Plug connector (male)
1	 <p data-bbox="687 680 836 712">S810-001202</p>	 <p data-bbox="1240 680 1388 712">S810-101202</p>
2	 <p data-bbox="687 1088 836 1120">S810-002202</p>	 <p data-bbox="1240 1088 1388 1120">S810-102202</p>
3	 <p data-bbox="687 1496 836 1527">S810-003202</p>	 <p data-bbox="1240 1496 1388 1527">S810-103202</p>
4	 <p data-bbox="687 1901 836 1933">S810-004202</p>	 <p data-bbox="1240 1901 1388 1933">S810-104202</p>

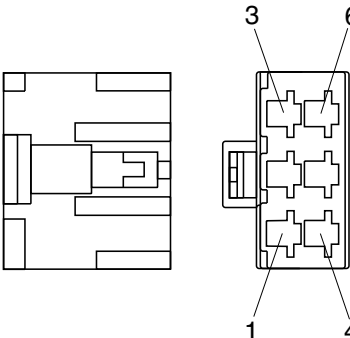
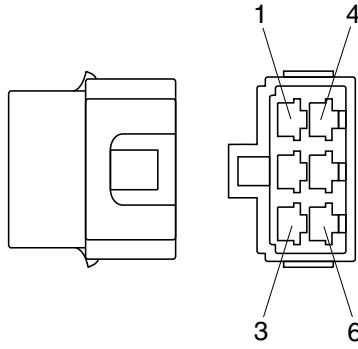
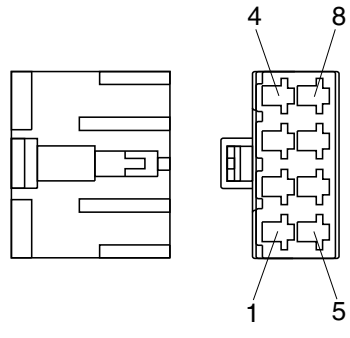
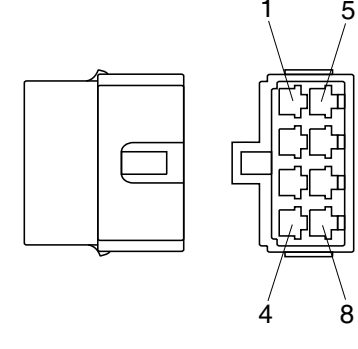
No. of pin	Receptacle connector (female)	Plug connector (male)
6	 <p data-bbox="686 638 837 672">S810-006202</p>	 <p data-bbox="1244 638 1396 672">S810-106202</p>
8	 <p data-bbox="686 1041 837 1075">S810-008202</p>	 <p data-bbox="1244 1041 1396 1075">S810-108202</p>

5) 375 FASTEN TYPE CONNECTOR

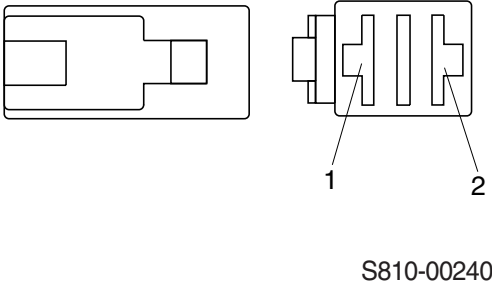
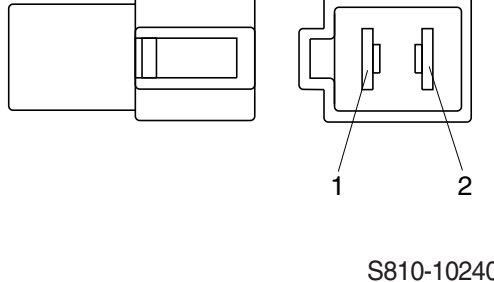
No. of pin	Receptacle connector (female)	Plug connector (male)
2	 <p style="text-align: center;">S810-002402</p>	 <p style="text-align: center;">S810-102402</p>

6) AMP ECONOSEAL CONNECTOR

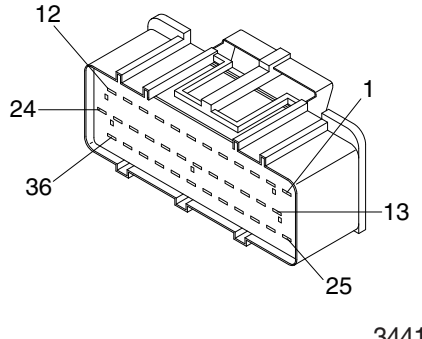
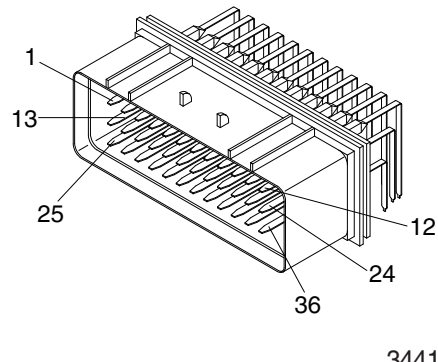
No. of pin	Receptacle connector (female)	Plug connector (male)
36	 <p style="text-align: center;">344111-1</p>	 <p style="text-align: center;">344108-1</p>

7) AMP TIMER CONNECTOR

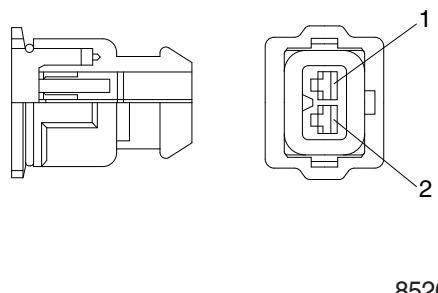
No. of pin	Receptacle connector (female)	Plug connector (male)
2	 <p style="text-align: center;">85202-1</p>	

8) AMP 040 MULTILOCK CONNECTOR

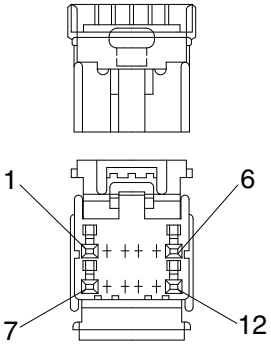
No. of pin	Receptacle connector (female)	Plug connector (male)
12	 <p style="text-align: right;">174045-2</p>	

9) AMP 070 MULTILOCK CONNECTOR

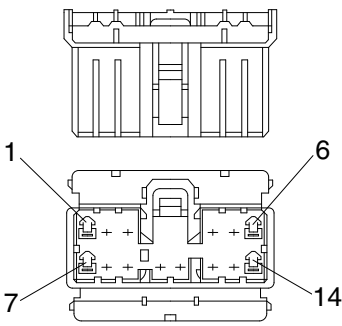
No. of pin	Receptacle connector (female)	Plug connector (male)
14	 <p style="text-align: right;">173852</p>	

10) AMP FASTIN - FASTON CONNECTOR

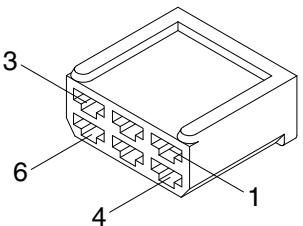
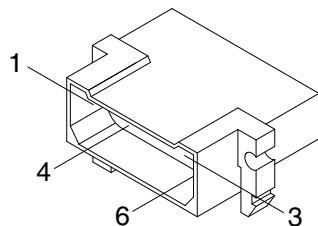
No. of pin	Receptacle connector (female)	Plug connector (male)
6	 <p style="text-align: right;">925276-0</p>	 <p style="text-align: right;">480003-9</p>

11) KET 090 CONNECTOR

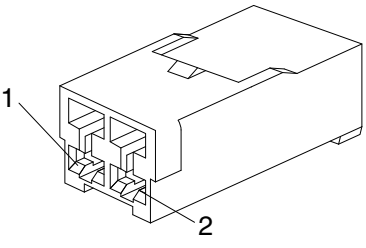
No. of pin	Receptacle connector (female)	Plug connector (male)
2	 <p style="text-align: right;">MG610070</p>	

12) KET 090 WP CONNECTORS

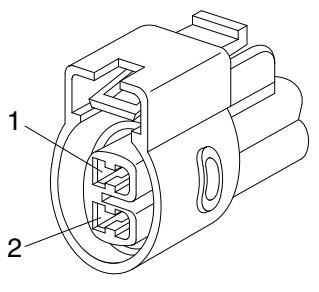
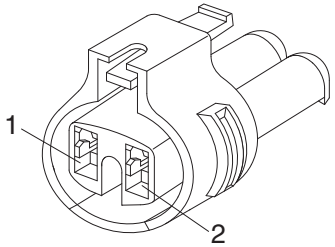
No. of pin	Receptacle connector (female)	Plug connector (male)
2	 <p style="text-align: right;">MG640605</p>	
2	 <p style="text-align: right;">MG640795</p>	

13) KET SDL CONNECTOR

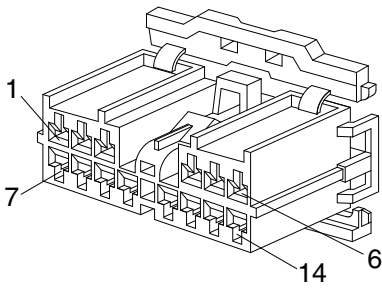
No. of pin	Receptacle connector (female)	Plug connector (male)
14	 <p data-bbox="710 683 837 705">MG610406</p>	

14) DEUTSCH DT CONNECTORS

DT 06 - 3S - ★★☆☆

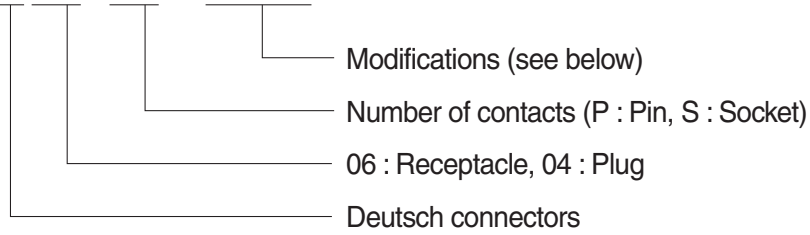

※ Modification

E003 : Standard end cap - gray

E004 : Color of connector to be black

E005 : Combination - E004 & E003

EP04 : End cap

EP06 : Combination P012 & EP04

P012 : Front seal enhancement - connectors color to black for 2, 3, 4 & 6pin

No. of pin	Receptacle connector (female)	Plug connector (male)
2	<p>DT06-2S</p>	<p>DT04-2P</p>
3	<p>DT06-3S</p>	<p>DT04-3P</p>
4	<p>DT06-4S</p>	<p>DT04-4P</p>

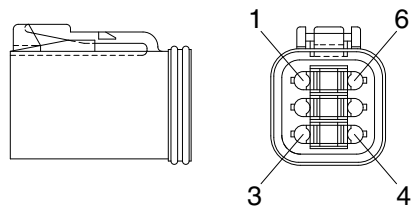
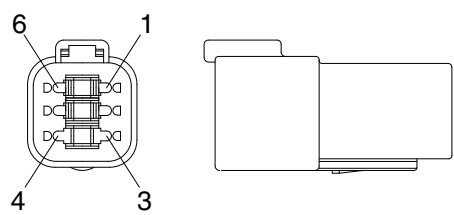
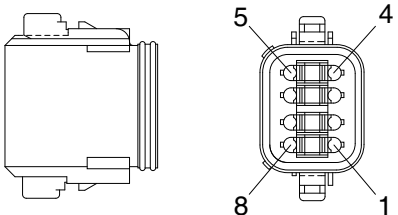
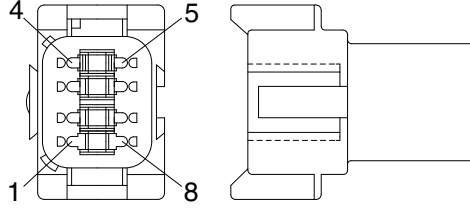
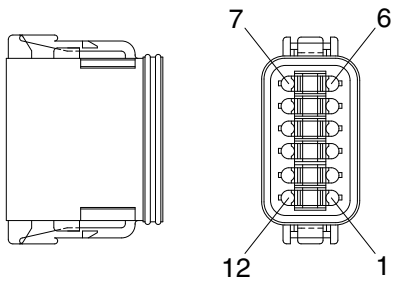
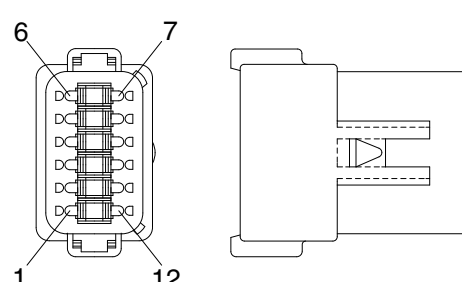
No. of pin	Receptacle connector (female)	Plug connector (male)
6	 <p style="text-align: center;">DT06-6S</p>	 <p style="text-align: center;">DT04-6P</p>
8	 <p style="text-align: center;">DT06-8S</p>	 <p style="text-align: center;">DT04-8P</p>
12	 <p style="text-align: center;">DT06-12S</p>	 <p style="text-align: center;">DT04-12P</p>

15) MOLEX 2CKTS CONNECTOR

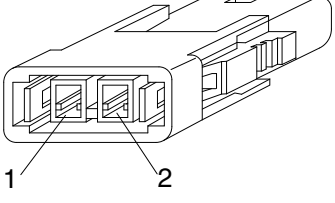
No. of pin	Receptacle connector (female)	Plug connector (male)
2	 <p style="text-align: right;">35215-0200</p>	

16) ITT SWF CONNECTOR

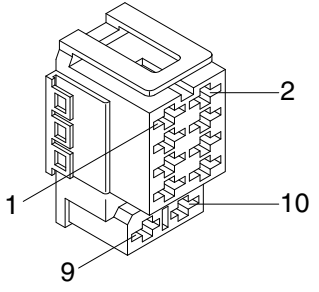
No. of pin	Receptacle connector (female)	Plug connector (male)
10	 <p style="text-align: right;">SWF593757</p>	

17) MWP NMWP CONNECTOR

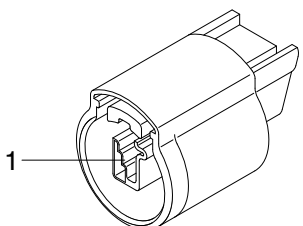
No. of pin	Receptacle connector (female)	Plug connector (male)
1	 <p style="text-align: right;">NMWP01F-B</p>	

18) ECONOSEAL J TYPE CONNECTORS

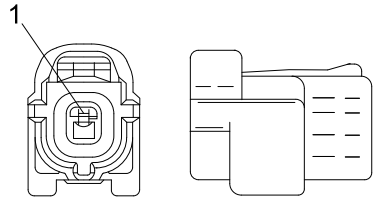
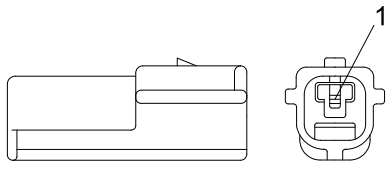
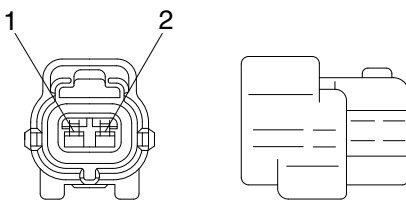
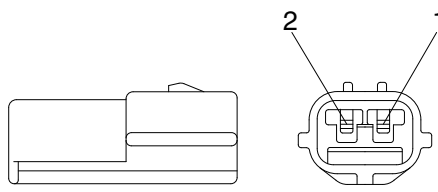
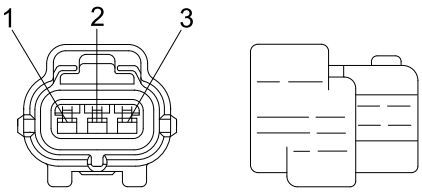
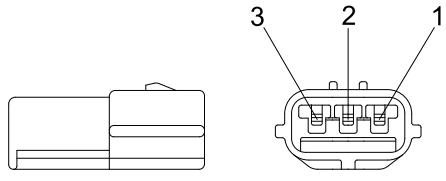
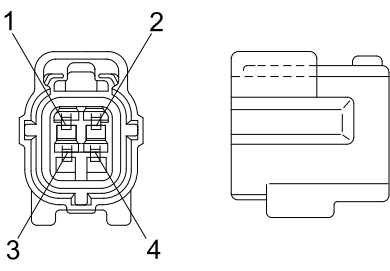
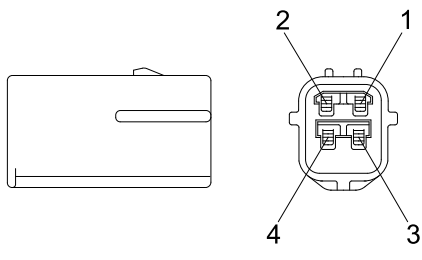
No. of pin	Receptacle connector (female)	Plug connector (male)
1	 <p style="text-align: right;">S816-001002</p>	 <p style="text-align: left;">S816-101002</p>
2	 <p style="text-align: right;">S816-002002</p>	 <p style="text-align: left;">S816-102002</p>
3	 <p style="text-align: right;">S816-003002</p>	 <p style="text-align: left;">S816-103002</p>
4	 <p style="text-align: right;">S816-004002</p>	 <p style="text-align: left;">S816-104002</p>

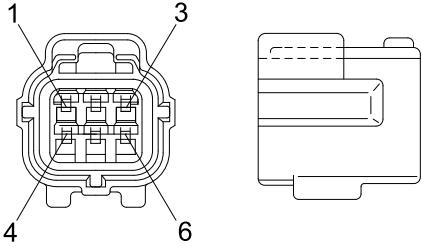
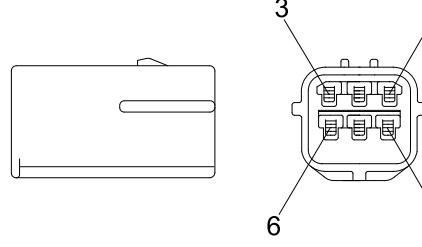
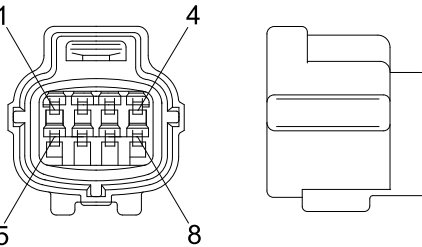
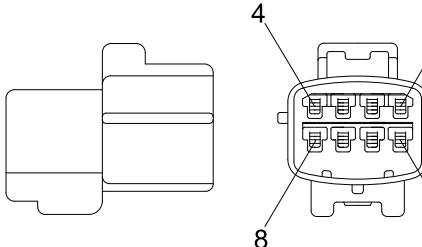
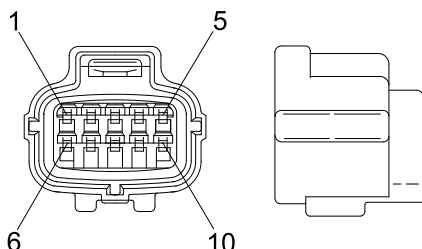
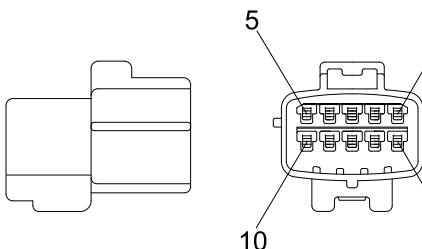
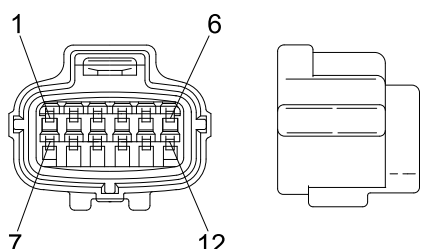
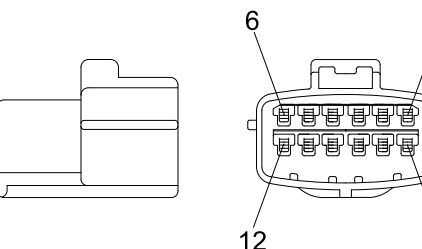
No. of pin	Receptacle connector (female)	Plug connector (male)
6	 <p style="text-align: center;">S816-006002</p>	 <p style="text-align: center;">S816-106002</p>
8	 <p style="text-align: center;">S816-008002</p>	 <p style="text-align: center;">S816-108002</p>
10	 <p style="text-align: center;">S816-010002</p>	 <p style="text-align: center;">S816-110002</p>
12	 <p style="text-align: center;">S816-012002</p>	 <p style="text-align: center;">S816-112002</p>

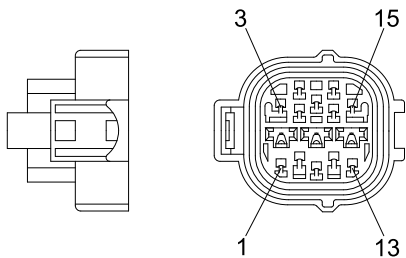
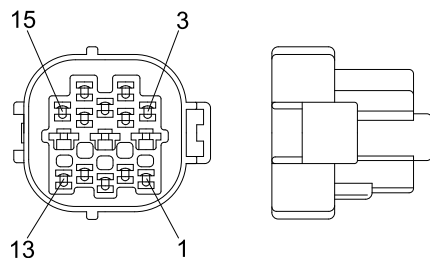
No. of pin	Receptacle connector (female)	Plug connector (male)
15	 <p style="text-align: right;">368301-1</p>	 <p style="text-align: right;">2-85262-1</p>

19) METRI-PACK TYPE CONNECTOR

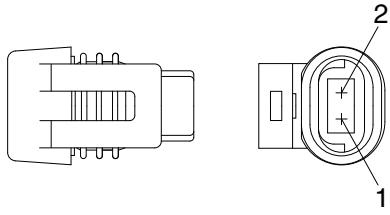
No. of pin	Receptacle connector (female)	Plug connector (male)
2	 <p style="text-align: right;">12040753</p>	

20) DEUTSCH HD30 CONNECTOR

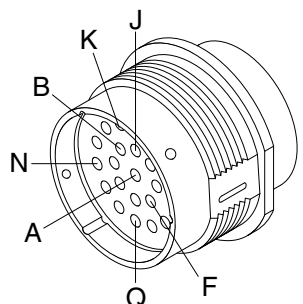
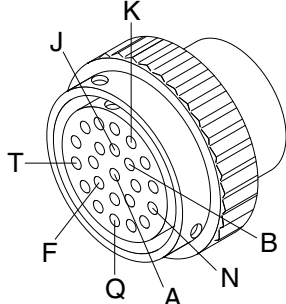
No. of pin	Receptacle connector (female)	Plug connector (male)
23	 <p style="text-align: right;">HD36-24-23SN</p>	 <p style="text-align: right;">HD34-24-23PN</p>

21) DEUTSCH MCU CONNECTOR

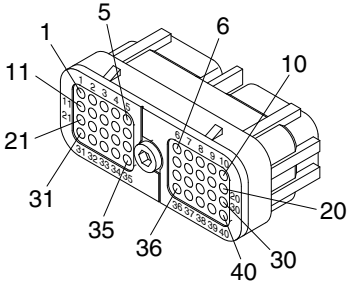
No. of pin	Receptacle connector (Female)	Plug connector (Male)
40	 <p style="text-align: right;">DRC26-40SA/B</p>	

22) DEUTSCH SERVICE TOOL CONNECTOR

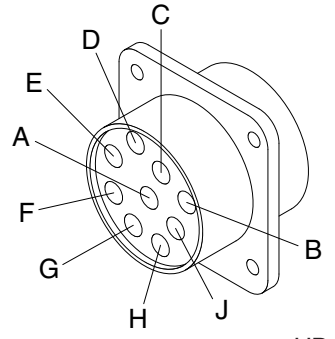
No. of pin	Receptacle connector (Female)	Plug connector (Male)
9	 <p style="text-align: right;">HD10-9-96P</p>	

23) AMP FUEL WARMER CONNECTOR

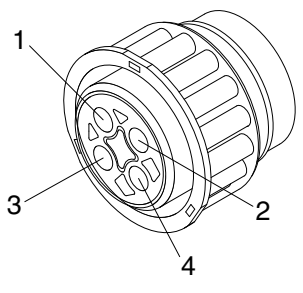
No. of pin	Receptacle connector (Female)	Plug connector (Male)
4	 <p style="text-align: right;">2-967325-3</p>	

24) DEUTSCH ENGINE ECM CONNECTOR

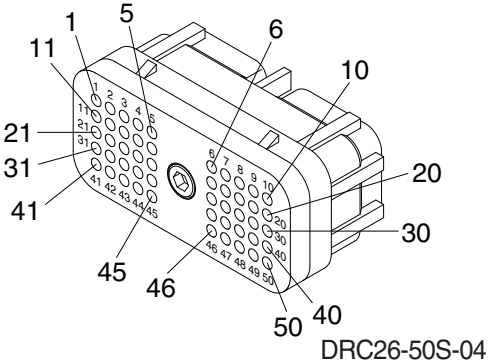
No. of pin	Receptacle connector (Female)	Plug connector (Male)
50	 <p style="text-align: right;">DRC26-50S-04</p>	

25) DEUTSCH INTERMEDIATE CONNECTOR

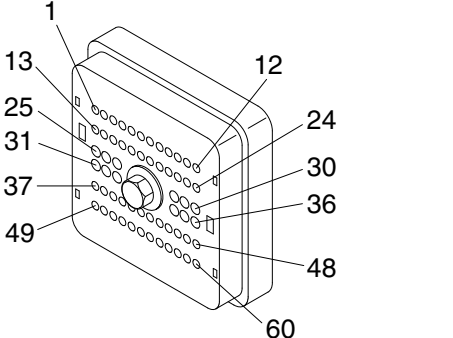
No. of pin	Receptacle connector (Female)	Plug connector (Male)
60	 <p style="text-align: right;">DRB16-60SAE-L018</p>	