

SECTION 8 DISASSEMBLY AND ASSEMBLY

Group 1 Precaution	8-1
Group 2 Tightening Torque	8-4
Group 3 Pump Device	8-7
Group 4 Main Control Valve	8-32
Group 5 Swing Device	8-46
Group 6 Travel Device	8-92
Group 7 RCV Lever	8-178
Group 8 Turning Joint	8-192
Group 9 Boom, Arm, Bucket and Dozer Cylinders	8-197
Group 10 Undercarriage	8-215
Group 11 Work Equipment	8-227

SECTION 8 DISASSEMBLY AND ASSEMBLY

GROUP 1 PRECAUTIONS

1. REMOVAL WORK

- 1) Lower the work equipment completely to the ground.
If the coolant contains antifreeze, dispose of it correctly.
- 2) After disconnecting hoses or tubes, cover them or fit blind plugs to prevent dirt or dust from entering.
- 3) When draining oil, prepare a container of adequate size to catch the oil.
- 4) Confirm the match marks showing the installation position, and make match marks in the necessary places before removal to prevent any mistake when assembling.
- 5) To prevent any excessive force from being applied to the wiring, always hold the connectors when disconnecting the connectors.
- 6) Fit wires and hoses with tags to show their installation position to prevent any mistake when installing.
- 7) Check the number and thickness of the shims, and keep in a safe place.
- 8) When raising components, be sure to use lifting equipment of ample strength.
- 9) When using forcing screws to remove any components, tighten the forcing screws alternately.
- 10) Before removing any unit, clean the surrounding area and fit a cover to prevent any dust or dirt from entering after removal.
- 11) When removing hydraulic equipment, first release the remaining pressure inside the hydraulic tank and the hydraulic piping.
- 12) If the part is not under hydraulic pressure, the following corks can be used.

Nominal number	Dimensions		
	D	d	L
06	6	5	8
08	8	6.5	11
10	10	8.5	12
12	12	10	15
14	14	11.5	18
16	16	13.5	20
18	18	15	22
20	20	17	25
22	22	18.5	28
24	24	20	30
27	27	22.5	34

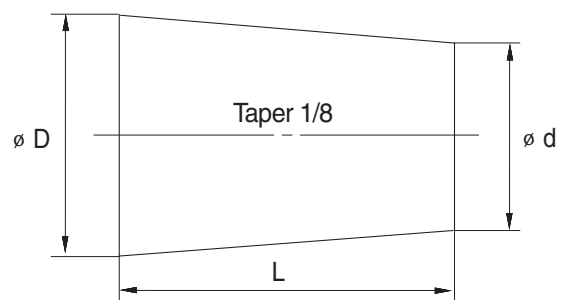

2. INSTALL WORK

- 1) Tighten all bolts and nuts (sleeve nuts) to the specified torque.
- 2) Install the hoses without twisting or interference.
- 3) Replace all gaskets, O-rings, cotter pins, and lock plates with new parts.
- 4) Bend the cotter pin or lock plate securely.
- 5) When coating with adhesive, clean the part and remove all oil and grease, then coat the threaded portion with 2-3 drops of adhesive.
- 6) When coating with gasket sealant, clean the surface and remove all oil and grease, check that there is no dirt or damage, then coat uniformly with gasket sealant.
- 7) Clean all parts, and correct any damage, dents, burrs, or rust.
- 8) Coat rotating parts and sliding parts with engine oil.
- 9) When press fitting parts, coat the surface with antifriction compound (LM-P).
- 10) After installing snap rings, check that the snap ring is fitted securely in the ring groove (Check that the snap ring moves in the direction of rotation).
- 11) When connecting wiring connectors, clean the connector to remove all oil, dirt, or water, then connect securely.
- 12) When using eyebolts, check that there is no deformation or deterioration, and screw them in fully.
- 13) When tightening split flanges, tighten uniformly in turn to prevent excessive tightening on one side.
- 14) When operating the hydraulic cylinders for the first time after repairing and reassembling the hydraulic cylinders, pumps, or other hydraulic equipment or piping, always bleed the air from the hydraulic cylinders as follows:
 - (1) Start the engine and run at low idling.
 - (2) Operate the control lever and actuate the hydraulic cylinder 4-5 times, stopping 100mm before the end of the stroke.
 - (3) Next, operate the piston rod to the end of its stroke to relieve the circuit. (The air bleed valve is actuated to bleed the air.)
 - (4) After completing this operation, raise the engine speed to the normal operating condition.
 - ※ If the hydraulic cylinder has been replaced, carry out this procedure before assembling the rod to the work equipment.
 - ※ Carry out the same operation on machines that have been in storage for a long time after completion of repairs.

3. COMPLETING WORK

- 1) If the coolant has been drained, tighten the drain valve, and add water to the specified level. Run the engine to circulate the water through the system. Then check the water level again.
- 2) If the hydraulic equipment has been removed and installed again, add engine oil to the specified level. Run the engine to circulate the oil through the system. Then check the oil level again.
- 3) If the piping or hydraulic equipment, such as hydraulic cylinders, pumps, or motors, have been removed for repair, always bleed the air from the system after reassembling the parts.
- 4) Add the specified amount of grease (molybdenum disulphied grease) to the work equipment related parts.

GROUP 2 TIGHTENING TORQUE

1. MAJOR COMPONENTS

No.	Descriptions	Bolt size	Torque		
			kgf · m	lbf · ft	
1	Engine	Engine mounting bolt (engine-bracket, FR)	M12 × 1.75	12.3 ± 1.2	89 ± 8.7
2		Engine mounting bolt (engine-bracket, RR)	M12 × 1.75	12.3 ± 1.2	89 ± 8.7
3		Engine mounting bolt (bracket-frame, FR)	M16 × 2.0	34 ± 4.0	246 ± 28.9
4		Engine mounting bolt (bracket-frame, RR)	M16 × 2.0	34 ± 4.0	246 ± 28.9
5		Radiator mounting bolt	M16 × 2.0	29.7 ± 4.5	215 ± 32.5
6		Coupling mounting socket bolt	M16 × 2.0	32.0 ± 1.6	231 ± 11.6
7		Main pump housing mounting bolt	M10 × 1.5	6.5 ± 0.7	47 ± 5.06
8	Hydraulic system	Main pump mounting socket bolt	M16 × 2.0	22 ± 1.5	159 ± 10.9
9		Main control valve mounting bolt	M12 × 1.75	12.2 ± 1.3	88.2 ± 9.4
10		Fuel tank mounting bolt	M20 × 2.5	46 ± 5.0	333 ± 36.2
11		Hydraulic oil tank mounting bolt	M20 × 2.5	46 ± 5.0	333 ± 36.2
12		Turning joint mounting bolt, nut	M12 × 1.75	12.8 ± 3.0	92.6 ± 21.7
13	Power train system	Swing motor mounting bolt	M16 × 2.0	29.6 ± 3.2	214 ± 23.1
14		Swing bearing upper part mounting bolt	M18 × 2.5	41.3 ± 4.0	299 ± 28.9
15		Swing bearing lower part mounting bolt	M16 × 1.5	29.7 ± 3.0	215 ± 21.7
16		Travel motor mounting bolt	M16 × 2.0	25.7 ± 4.0	186 ± 28.9
17		Sprocket mounting bolt	M16 × 2.0	29.7 ± 3.0	215 ± 21.7
18	Under carriage	Carrier roller mounting bolt, nut	M16 × 2.0	29.7 ± 3.0	215 ± 21.7
19		Track roller mounting bolt	M16 × 2.0	29.7 ± 3.0	215 ± 21.7
20		Track tension cylinder mounting bolt	M16 × 2.0	29.7 ± 4.5	215 ± 32.5
21		Track shoe mounting bolt, nut	5/8 - 18UNF	42 ± 4.0	304 ± 28.9
22		Track guard mounting bolt	M16 × 2.0	29.6 ± 3.2	214 ± 23.1
23	Others	Counterweight mounting bolt	M36 × 3.0	308 ± 46	2228 ± 333
24		Cab mounting bolt	M12 × 1.75	12.8 ± 3.0	92.6 ± 21.7
25		Operator's seat mounting bolt	M 8 × 1.25	4.05 ± 0.8	29.3 ± 5.8

※ For tightening torque of engine and hydraulic components, see engine maintenance guide and service manual.

2. TORQUE CHART

Use following table for unspecified torque.

1) BOLT AND NUT

(1) Coarse thread

Bolt size	8.8T		10.9T		12.9T	
	kgf·m	lbf·ft	kgf·m	lbf·ft	kgf·m	lbf·ft
M 6 × 1.0	0.8 ~ 1.2	5.8 ~ 8.6	1.2 ~ 1.8	8.7 ~ 13.0	1.5 ~ 2.1	10.9 ~ 15.1
M 8 × 1.25	2.0 ~ 3.0	14.5 ~ 21.6	2.8 ~ 4.2	20.3 ~ 30.4	3.4 ~ 5.0	24.6 ~ 36.1
M10 × 1.5	4.0 ~ 6.0	29.0 ~ 43.3	5.6 ~ 8.4	40.5 ~ 60.8	6.8 ~ 10.0	49.2 ~ 72.3
M12 × 1.75	6.8 ~ 10.2	50.0 ~ 73.7	9.6 ~ 14.4	69.5 ~ 104	12.3 ~ 16.5	89.0 ~ 119
M14 × 2.0	10.9 ~ 16.3	78.9 ~ 117	16.3 ~ 21.9	118 ~ 158	19.5 ~ 26.3	141 ~ 190
M16 × 2.0	17.9 ~ 24.1	130 ~ 174	25.1 ~ 33.9	182 ~ 245	30.2 ~ 40.8	141 ~ 295
M18 × 2.5	24.8 ~ 33.4	180 ~ 241	34.8 ~ 47.0	252 ~ 340	41.8 ~ 56.4	302 ~ 407
M20 × 2.5	34.9 ~ 47.1	253 ~ 340	49.1 ~ 66.3	355 ~ 479	58.9 ~ 79.5	426 ~ 575
M22 × 2.5	46.8 ~ 63.2	339 ~ 457	65.8 ~ 88.8	476 ~ 642	78.9 ~ 106	570 ~ 766
M24 × 3.0	60.2 ~ 81.4	436 ~ 588	84.6 ~ 114	612 ~ 824	102 ~ 137	738 ~ 991
M30 × 3.5	120 ~ 161	868 ~ 1164	168 ~ 227	1216 ~ 1641	202 ~ 272	1461 ~ 1967

(2) Fine thread

Bolt size	8.8T		10.9T		12.9T	
	kgf · m	lbf · ft	kgf · m	lbf · ft	kgf · m	lbf · ft
M 8 × 1.0	2.1 ~ 3.1	15.2 ~ 22.4	3.0 ~ 4.4	21.7 ~ 31.8	3.6 ~ 5.4	26.1 ~ 39.0
M10 × 1.25	4.2 ~ 6.2	30.4 ~ 44.9	5.9 ~ 8.7	42.7 ~ 62.9	7.0 ~ 10.4	50.1 ~ 75.2
M12 × 1.25	7.3 ~ 10.9	52.8 ~ 78.8	10.3 ~ 15.3	74.5 ~ 110	13.1 ~ 17.7	94.8 ~ 128
M14 × 1.5	12.4 ~ 16.6	89.7 ~ 120	17.4 ~ 23.4	126 ~ 169	20.8 ~ 28.0	151 ~ 202
M16 × 1.5	18.7 ~ 25.3	136 ~ 182	26.3 ~ 35.5	191 ~ 256	31.6 ~ 42.6	229 ~ 308
M18 × 1.5	27.1 ~ 36.5	196 ~ 264	38.0 ~ 51.4	275 ~ 371	45.7 ~ 61.7	331 ~ 446
M20 × 1.5	37.7 ~ 50.9	273 ~ 368	53.1 ~ 71.7	384 ~ 518	63.6 ~ 86.0	460 ~ 622
M22 × 1.5	51.2 ~ 69.2	370 ~ 500	72.0 ~ 97.2	521 ~ 703	86.4 ~ 116	625 ~ 839
M24 × 2.0	64.1 ~ 86.5	464 ~ 625	90.1 ~ 121	652 ~ 875	108 ~ 146	782 ~ 1056
M30 × 2.0	129 ~ 174	933 ~ 1258	181 ~ 245	1310 ~ 1772	217 ~ 294	1570 ~ 2126

2) PIPE AND HOSE (FLARE TYPE)

Thread size (PF)	Width across flat (mm)	kgf · m	lbf · ft
1/4"	19	4	28.9
3/8"	22	5	36.2
1/2"	27	9.5	68.7
3/4"	36	18	130
1"	41	21	152
1-1/4"	50	35	253

3) PIPE AND HOSE (ORFS TYPE)

Thread size (UNF)	Width across flat (mm)	kgf · m	lbf · ft
9/16-18	19	4	28.9
11/16-16	22	5	36.2
13/16-16	27	9.5	68.7
1-3/16-12	36	18	130
1-7/16-12	41	21	152
1-11/16-12	50	35	253

4) FITTING

Thread size	Width across flat (mm)	kgf · m	lbf · ft
1/4"	19	4	28.9
3/8"	22	5	36.2
1/2"	27	9.5	68.7
3/4"	36	18	130
1"	41	21	152
1-1/4"	50	35	253

GROUP 3 PUMP DEVICE

1. REMOVAL AND INSTALL

1) REMOVAL

- (1) Lower the work equipment to the ground and stop the engine.
- (2) Operate the control levers and pedals several times to release the remaining pressure in the hydraulic piping
- (3) Loosen the breather slowly to release the pressure inside the hydraulic tank.

▲ Escaping fluid under pressure can penetrate the skin causing serious injury.

- (4) Loosen the drain plug under the hydraulic tank and drain the oil from the hydraulic tank.

· Hydraulic tank quantity : 96 l (25.4 U.S. gal)

- (5) Remove socket bolts (11) and disconnect hoses (1,2).

- (6) Disconnect pilot line hoses (5, 6, 7, 8, 9, 10).

- (7) Remove socket bolts (12) and disconnect pump suction pipe (4).

※ When pump suction tube is disconnected, the oil inside the piping will flow out, so catch it in oil pan.

- (8) Sling the pump assembly and remove the pump mounting bolts.

· Weight : 90 kg (200 lb)

※ Pull out the pump assembly from housing.

When removing the pump assembly, check that all the hoses have been disconnected.

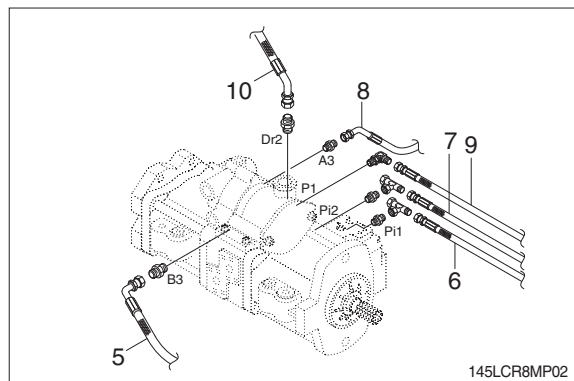
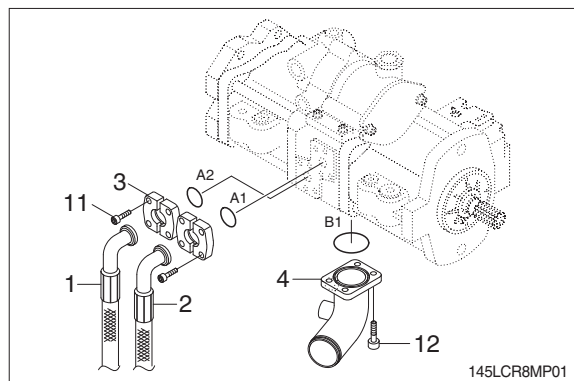

2) INSTALL

- (1) Carry out installation in the reverse order to removal.
- (2) Remove the suction strainer and clean it.
- (3) Replace return filter with new one.
- (4) Remove breather and clean it.
- (5) After adding oil to the hydraulic tank to the specified level.
- (6) Bleed the air from the hydraulic pump.
 - ① Remove the air vent plug (2EA).
 - ② Tighten plug lightly.
 - ③ Start the engine, run at low idling, and check oil come out from plug.
 - ④ Tighten plug.
- (7) Start the engine, run at low idling (3~5 minutes) to circulate the oil through the system.
- (8) Confirm the hydraulic oil level and check the hydraulic oil leak or not.

2. MAIN PUMP

1) STRUCTURE (1/2)

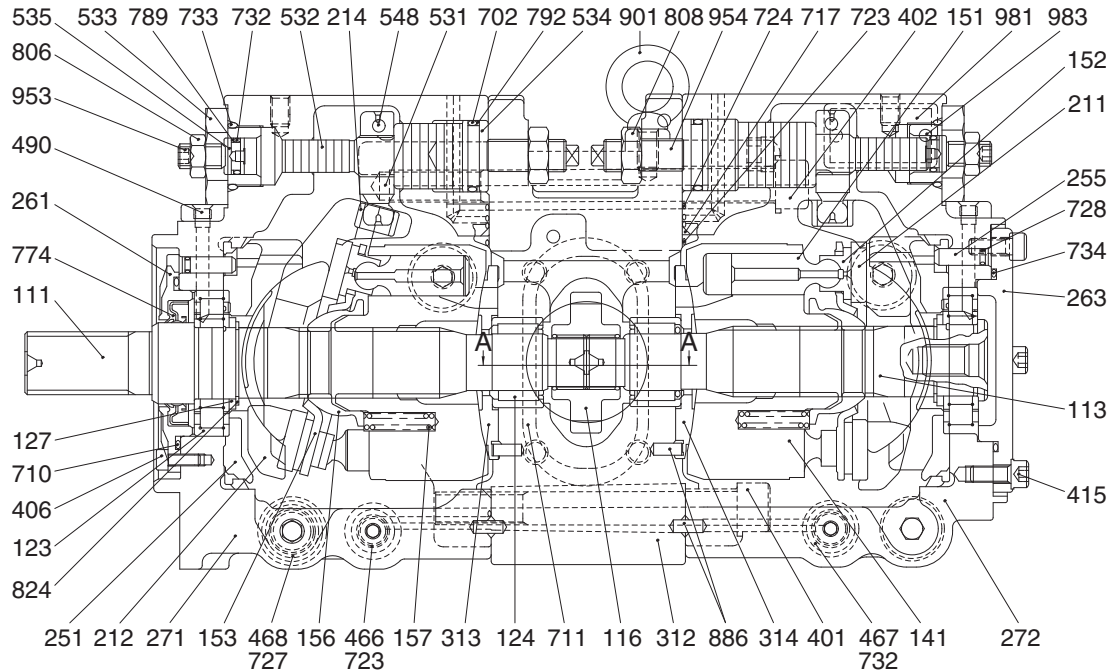

140Z92MP02

111	Drive shaft (F)	272	Pump casing (R)	711	O-ring
113	Drive shaft (R)	312	Valve block	717	O-ring
116	1st Gear	313	Valve plate (R)	723	O-ring
123	Roller bearing	314	Valve plate (L)	724	O-ring
124	Needle bearing	401	Hexagon socket bolt	728	O-ring
127	Bearing spacer	402	Hexagon socket bolt	732	O-ring
141	Cylinder block	406	Hexagon socket bolt	733	O-ring
151	Piston	415	Hexagon socket bolt	734	O-ring
152	Shoe	466	Plug	774	Oil seal
153	Set plate	467	plug	789	Back up ring
156	Bushing	468	Plug	792	Back up ring
157	Cylinder spring	490	Plug	806	Nut
211	Shoe plate	531	Tilting pin	808	Hexagon head nut
212	Swash plate	532	Servo piston	824	Snap ring
214	Bushing	533	Plug	886	Spring pin
251	Support	534	Stopper (L)	901	Eye bolt
255	Lock pin	535	Stopper (S)	953	Set screw
261	Seal cover (F)	548	Pin	954	Set screw
263	Seal cover (R)	702	O-ring	981	Plate
271	Pump casing (F)	710	O-ring	983	Pin

STRUCTURE (2/2)

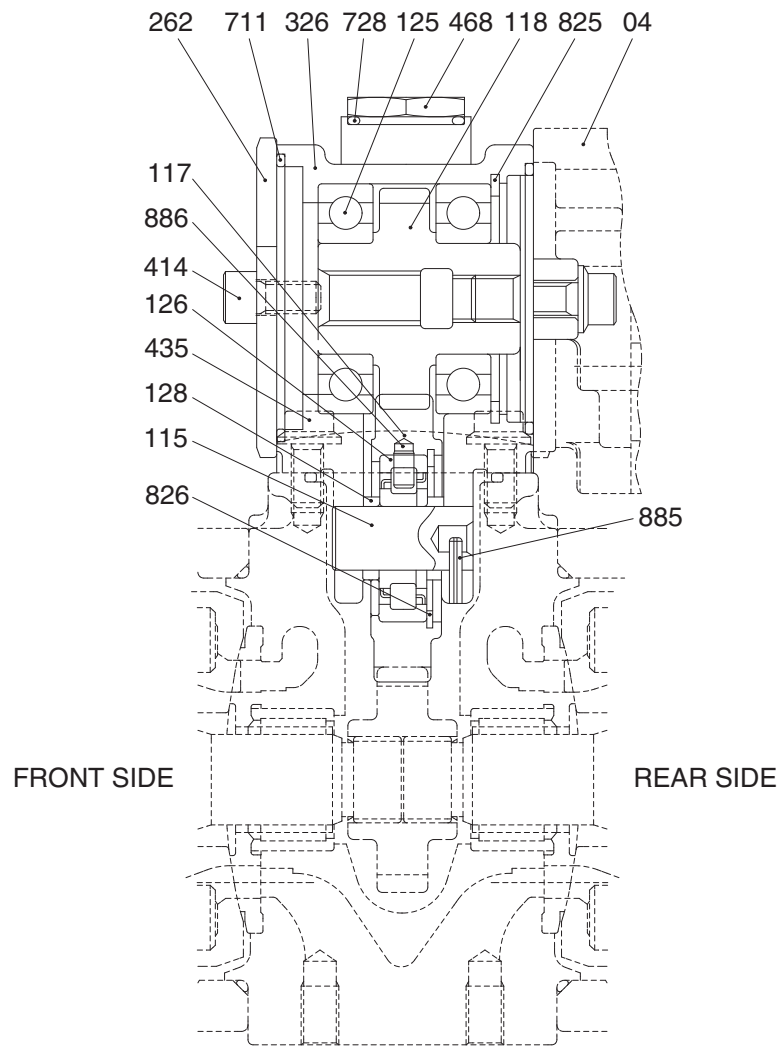

140Z92MP03

04	Gear pump	128	Bearing spacer	711	O-ring
115	Shaft	262	Cover	728	O-ring
117	Gear No. 2	326	Gear case	825	Retainer ring
118	Gear No. 3	414	Hexagon socket bolt	826	Retainer ring
125	Ball bearing	435	Flange socket bolt	885	Spring pin
126	Roller bearing	468	Plug	886	Pin

2) TOOLS AND TIGHTENING TORQUE

(1) Tools

The tools necessary to disassemble/reassemble the pump are shown in the follow list.

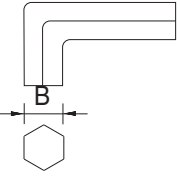
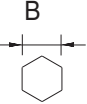
Tool name & size		Part name			
Name	B	Hexagon socket head bolt	PT plug (PT thread)	ROH/VP/UNF plug (PF screw)	Hexagon socket head setscrew
Allen wrench 	4	M 5	BP-1/16	-	M 8
	5	M 6	BP-1/8	-	M10
	6	M 8	BP-1/4	PF-1/4	M12, M14
	8	M10	BP-3/8	PF-3/8	M16, M18
	10	M12	BP-1/2	PF-1/2	M20
	14	M16, M18	BP-3/4	PF-3/4	-
	17	M20, M22	BP-1	PF-1	-
Double ring spanner, socket wrench, double (single) open end spanner 	-	Hexagon bolt	Hexagon nut	VP plug (PF screw)	
	19	M12	M12	PF-1/4	
	24	M16	M16	-	
	27	M18	M18	PF-1/2	
	30	M20	M20	-	
	41	-	-	-	PF-1
Adjustable angle wrench		Medium size, 1 set			
Screw driver		Minus type screw driver, Medium size, 2 sets			
Hammer		Plastic hammer, 1 set			
Pliers		For snap ring, TSR-160			
Steel bar		Steel bar of key material approx. 10 × 8 × 200			
Torque wrench		Capable of tightening with the specified torques			

(2) Tightening torque

Part name	Bolt size	Torque		Wrench size	
		kgf · m	lbf · ft	in	mm
Hexagon socket head bolt (material : SCM435)	M 5	0.7	5.1	0.16	4
	M 6	1.2	8.7	0.20	5
	M 8	3.0	21.7	0.24	6
	M10	5.8	42.0	0.31	8
	M12	10.0	72.3	0.39	10
	M14	16.0	116	0.47	12
	M16	24.0	174	0.55	14
	M18	34.0	246	0.55	14
PT Plug (material : S45C) ※ Wind a seal tape 1.5 to 2 turns round the plug	PT1/16	0.7	5.1	0.16	4
	PT 1/8	1.05	7.59	0.20	5
	PT 1/4	1.75	12.7	0.24	6
	PT 3/8	3.5	25.3	0.31	8
	PT 1/2	5.0	36.2	0.39	10
PF Plug (material : S45C)	PF 1/4	3.0	21.7	0.24	6
	PF 3/8	7.55	54.6	0.31	8
	PF 1/2	10.0	72.3	0.39	10
	PF 3/4	15.0	109	0.55	14
	PF 1	19.0	137	0.67	17
	PF 1 1/4	27.0	195	0.67	17
	PF 1 1/2	28.0	203	0.67	17

3) DISASSEMBLY

- (1) Select place suitable to disassembling.
 - ※ Select clean place.
 - ※ Spread rubber sheet, cloth or so on overhaul workbench top to prevent parts from being damaged.
- (2) Remove dust, rust, etc, from pump surfaces with cleaning oil or so on.
- (3) Remove drain port plug (468) and drain oil pump casing (271, 272).
- (4) Remove hexagon socket head bolts (412, 413) and remove regulator.



140Z98MP11

- (5) Place pump horizontally on workbench with its regulator fitting surface down, and remove flange socket (435) and remove PTO unit (05).
 - ※ Be careful about the attaching direction of the PTO unit (05).
 - ※ Before bringing regulator fitting surface down, spread rubber sheet on workbench without fail to prevent this surface from being damaged.



140Z98MP12

- (6) In case the pump is provided without the PTO unit (05), remove the cover (262) with the hexagon socket head cap screws (414).



140Z98MP13

- (7) Remove flange socket (435) and remove gear pump (04).



140Z98MP14

- (8) Loosen hexagon socket head bolt (401) which tighten pump casing (271, 272) and valve block (312).



140Z98MP15

- (9) Place pump horizontally on workbench with its regulator fitting surface down, and separate pump casing (271,272) from valve block (312).

- ※ Remove 1st gear (116) when separating pump casing from valve block (312) too.

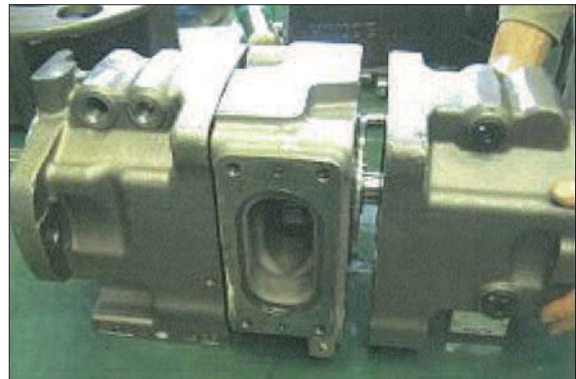

140Z98MP16

- (10) Pull out cylinder (141), pistons (151), set screw (153), spherical bush (156) and cylinder springs (157) simultaneously from pump casing (271, 272) straightly over drive shaft (111, 113).

- ※ Take care not to damage sliding surface of cylinder (141), spherical bush (156), shoes (152), swash plate (212), etc.



140Z98MP17

(11) Remove hexagon socket head bolts (406) and then seal cover (F, 261).

※ In the case removing it is difficult, and hooking pull thin rod into notch, and the cover can be removed easily.

※ Since oil seal is fitted on seal cover (F) (261), take care not to damage it at removing the cover.



140Z98MP18

(12) Tapping shaft ends of drive shaft (111, 113) lightly with plastic hammer, remove it from pump casing (271, 272).



140Z98MP19

(13) Remove shoe plate (211) and swash plate (212) from pump casing (271, 272).



140Z98MP20

(14) Insert thin steel bar into the hole and remove the lock pin (255) from pump casing (271, 272).

※ When holding with thin steel bar, do not confuse the unlocking hole with the arc shaped oil passage.



140Z98MP21

(15) Remove valve plate (313, 314) from valve block (312).

※ These may be removed in Work 8.



140Z98MP22

If necessary, remove stopper (L) (534), Qmin. plug (533), servo piston (532) and tilting pin (531) from pump casing (271, 272), and needle bearing (124) from valve block.

- ※ When removing tilting pin, use a protector to prevent pin head from being damaged.
- ※ Since lock tight is applied to fitting areas of tilting pin (531) and servo piston (532), take care not to damage servo piston (532).
- ※ Do not remove needle bearing (124) as far as possible, except the case that considered to be out of its life span.
- ※ Do not loosen hexagon nuts of valve block (312) and Qmin. plug (533).
If loosened, flow setting will be changed.

4) ASSEMBLY

(1) For reassembling reverse the disassembling procedures, paying attention to the following items.

- ① Do not fail to repair the parts damaged during disassembling, and repair replacement parts in advance.
- ② Clean each part fully with cleaning oil and dry it with compressed air.
- ③ Do not fail to apply clean working oil to sliding sections, bearings, etc. before assembling them.
- ④ In principle, replace seal parts, such as O-rings, oil seals, etc.
- ⑤ For fitting bolts, plug, etc., prepare a torque wrench or so on, and tighten them with torques shown in page 8-11, 12.
- ⑥ For the double-pump, take care not to mix up parts of the front pump with those of the rear pump.

(2) Insert the lock pin (255) after the swash plate support (251) into the pump casing (271, 272), and fit the lock pin (255) into the hole of the swash plate support (251).

- ※ In case the servo piston, tilting pin, stopper (L), stopper (S), and Qmin. plug have been removed, attached then to the pump casing in advance.
- ※ In the tightening work of the servo piston and the tilting pin, use the tool not to damaged the head of the tilting pin and the feed back pin. Besides, apply loctite (of medium strength) to the thread portion.

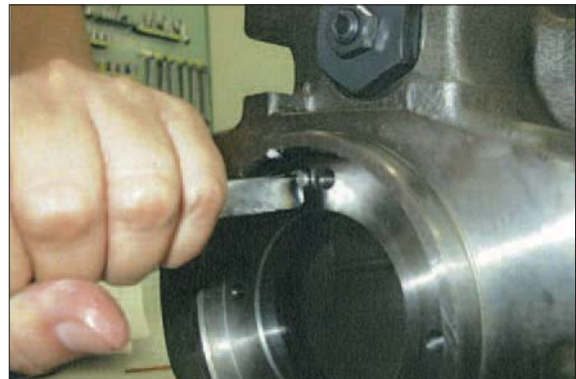

140Z98MP23

(3) Fit tilting bush (214) of swash plate (212) to tilting pin (531), and fit swash plate (212) with shoe plate (211) to swash plate support (251) correctly.

- ※ Confirm with fingers of both hands that swash plate can be removed smoothly.
- ※ Apply grease to sliding sections of swash plate (212) and swash plate support (251), and drive shaft (111, 113) can be fitted easily.
- ※ Take care not to damage shoe plate (211) surface.



140Z98MP24

(4) To pump casing (271, 272), fit drive shaft (111, 113) set with bearing (123), bearing spacer (127) and stop ring (824).



140Z98MP25

(5) In assemble of front pump, assemble seal cover (F) (261) to pump casing (271) and fix it with hexagon socket head bolt (406).

- ※ Apply grease lightly to oil seal in seal cover (F) (261).
- ※ For assemble oil seal (774), taking full care not to damage it.



140Z98MP26

(6) Assemble piston cylinder subassembly [cylinder (141), piston subassembly (151, 152), set plate (153), spherical bush (156) and cylinder spring (157)]. Fitting spline phases of cylinder, spherical bush (156) and drive shaft (111, 113), insert piston cylinder subassembly into pump casing (271, 272).



140Z98MP27

- (7) Fit valve plate (313, 314) to valve block (312), spring pin (886) into pin hole.
※ Take care not to mistake suction/delivery direction of valve plate (312).



140Z98MP28

- (8) Place pump horizontally on workbench with its regulator fitting surface down, and attach pump casing (271, 272) to valve block (312). Fit 1st gear (116) simultaneously.
※ Before bringing regulator fitting surface down, spread rubber sheet on workbench without fail to prevent this surface from being damaged.
※ Take care not to mistake direction of valve block (312). [Clockwise rotation (viewed from input shaft side)]. Fit the valve block (312) with suction flange left when regulator side below, viewed from front side.



140Z98MP29

- (9) Fix valve block (312) to pump casing (271, 272) with hexagon socket head bolts (401).



140Z98MP30

- (10) Fit gear pump (04) to pump casing (272) with hexagon socket head bolts (435).



140Z98MP31

- (11) Attach the PTO unit (05) by fastening the flange socket (435) to the valve block (312).



140Z98MP32

- (12) In case the pump is not provided with the PTO unit (05), attach the cover (262) with the hexagon socket head cap screw (414).



140Z98MP33

- (13) Putting feedback lever (611) of regulator into feedback pin (548) of tilting pin (531), fit regulator with hexagon socket head bolt (415).

※ Take care not to mix up regulator of front pump and that of rear pump.



140Z98MP34

- (14) Fit drain port plug (468).
This is the end of reassembling procedures.

3. REGULATOR

1) STRUCTURE (1/2)

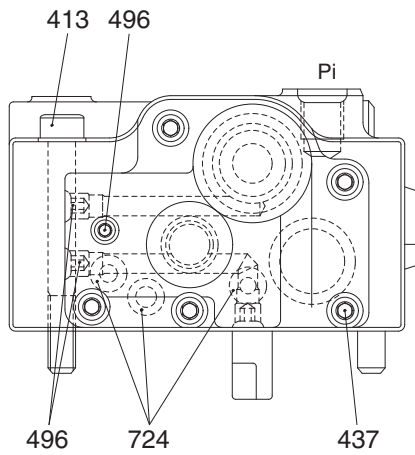
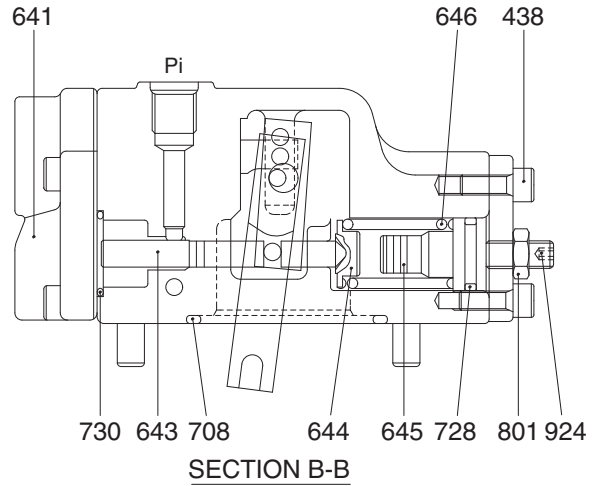
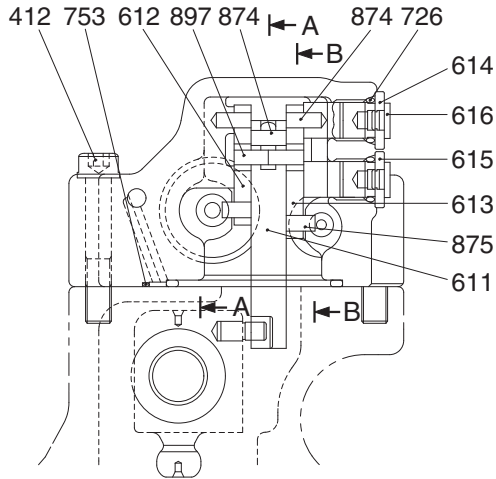

VIEW C (FRONT)

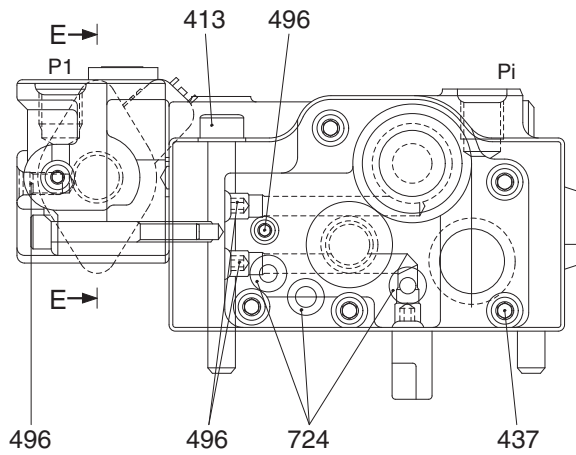

VIEW C (REAR)

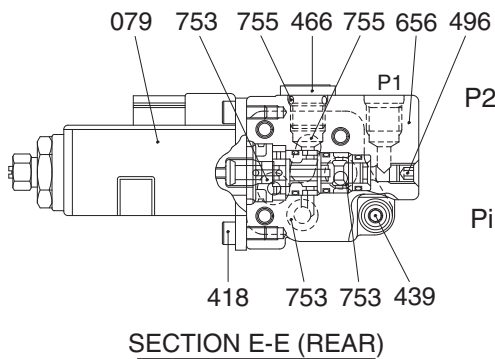

SECTION E-E (REAR)

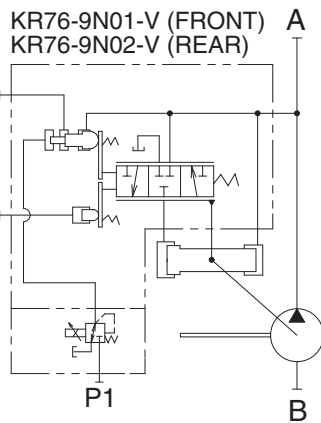

140Z92MP04

STRUCTURE (2/2)

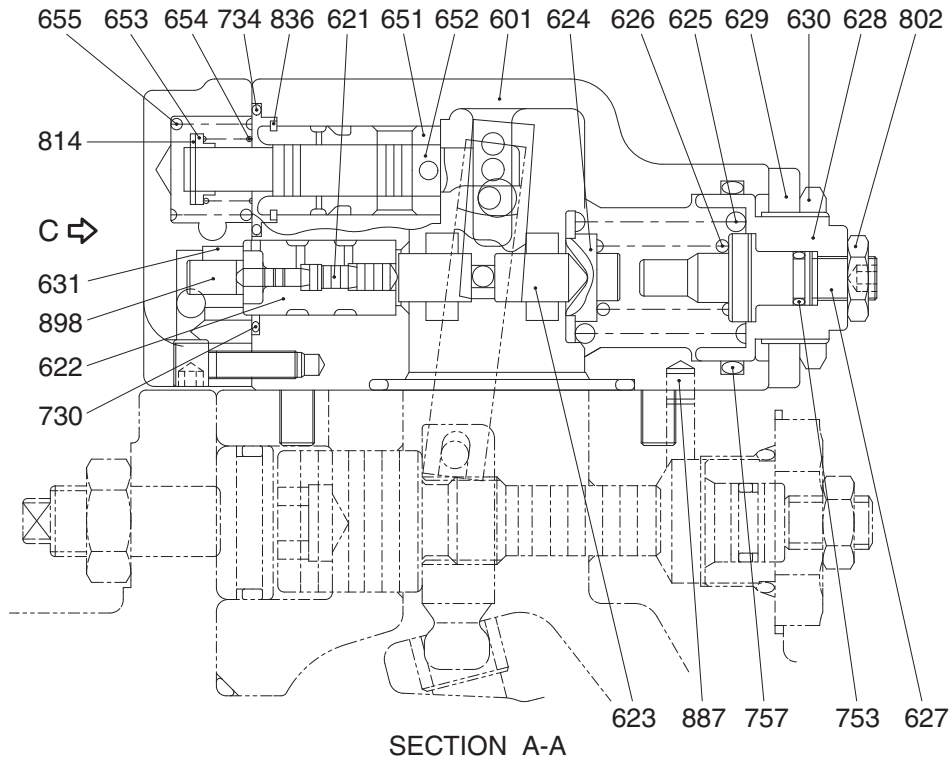



140Z92MP05

079	EPPR valve assembly	624	Spring seat (C)	708	O-ring
412	Hexagon socket screw	625	Outer spring	724	O-ring
413	Hexagon socket screw	626	Inner spring	725	O-ring
418	Hexagon socket screw	627	Adjust stem (C)	728	O-ring
437	Hexagon socket screw	628	Adjust screw (C)	730	O-ring
438	Hexagon socket screw	629	Cover (C)	734	O-ring
439	Hexagon socket screw	630	Lock nut	753	O-ring
466	Plug	631	Sleeve, Pf	755	O-ring
496	Plug	641	Pilot cover	757	O-ring
601	Casing	643	Pilot piston	801	Nut
611	Feed back lever	644	Spring seat (Q)	802	Nut
612	Lever (1)	645	Adjust stem (Q)	814	Snap ring
613	Lever (2)	646	Pilot spring	836	Snap ring
614	Center plug	651	Sleeve	874	Pin
615	Adjust plug	652	Spool	875	Pin
616	Plug	653	Spring seat	887	Pin
621	Compensator piston	654	Return spring	897	Pin
622	Piston case	655	Set spring	898	Pin
623	Compensator rod	656	Block cover	924	Set screw

2) TOOLS AND TIGHTENING TORQUE

(1) Tools

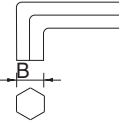
The tools necessary to disassemble/reassemble the pump are shown in the follow list.

Tool name & size		Part name			
Name	B	Hexagon socket head bolt	PT plug (PT thread)	PO plug (PF thread)	Hexagon socket head setscrew
Allen wrench 	4	M5	BP-1/16	-	M 8
	5	M6	BP-1/8	-	M10
	6	M8	BP-1/4	PO-1/4	M12, M14
Double ring spanner, socket wrench, double (single) open end spanner 	-	Hexagon head bolt	Hexagon nut	VP plug (PF thread)	
	6	M 8	M 8	-	
Adjustable angle wrench		Small size, Max 36 mm			
Screw driver		Minus type screw driver, Medium size, 2 sets			
Hammer		Plastic hammer, 1 set			
Pliers		For snap ring, TSR-160			
Steel bar		4 × 100 mm			
Torque wrench		Capable of tightening with the specified torques			
Pincers		-			
Bolt		M4, Length : 50 mm			

(2) Tightening torque

Part name	Bolt size	Torque		Wrench size	
		kgf · m	lbf · ft	in	mm
Hexagon socket head bolt (material : SCM435)	M 5	0.7	5.1	0.16	4
	M 6	1.2	8.7	0.20	5
	M 8	3.0	21.7	0.24	6
	M10	5.8	42.0	0.31	8
	M12	10.0	72.3	0.39	10
	M14	16.0	116	0.47	12
	M16	24.0	174	0.55	14
	M18	34.0	246	0.55	14
	M20	44.0	318	0.67	17
PT Plug (material : S45C) ※ Wind a seal tape 1 1/2 to 2 turns round the plug	PT1/16	0.7	5.1	0.16	4
	PT 1/8	1.05	7.59	0.20	5
	PT 1/4	1.75	12.7	0.24	6
	PT 3/8	3.5	25.3	0.31	8
	PT 1/2	5.0	36.2	0.39	10
PF Plug (material : S35C)	PF 1/4	3.0	21.7	0.24	6
	PF 1/2	10.0	72.3	0.39	10
	PF 3/4	15.0	109	0.55	14
	PF 1	19.0	137	0.67	17
	PF 1 1/4	27.0	195	0.67	17
	PF 1 1/2	28.0	203	0.67	17

3) DISASSEMBLY

Since the regulator consists of small precision finished parts, disassembly and assembly are rather complicated.

For this reason, replacement of a regulator assembly is recommended, unless there is a special reason, but in case disassembly is necessary for an unavoidable reason, read through this manual to the end before starting disassembly.

(1) Choose a place for disassembly.

- ※ Choose a clean place.
- ※ Spread rubber sheet, cloth, or so on on top of work-bench to prevent parts from being damaged.

(2) Remove dust, rust, etc. from surfaces of regulator with clean oil.

(3) Remove hexagon socket head screw (412, 413) and remove regulator main body from pump main body.

- ※ Take care not to lose O-ring.

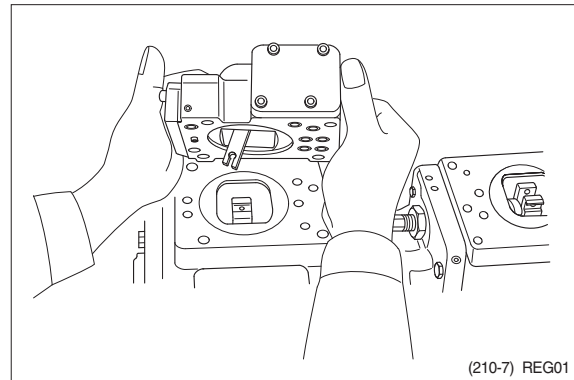

(4) Remove hexagon socket head screw (438) and remove cover (C,629)

- ※ Cover (C) is fitted with adjusting screw (C, 628), adjusting ring (C, 627), lock nut (630), hexagon nut (801) and adjusting screw (924).

- ※ Do not loosen these screws and nuts. If they are loosened, adjusted pressure-flow setting will vary.

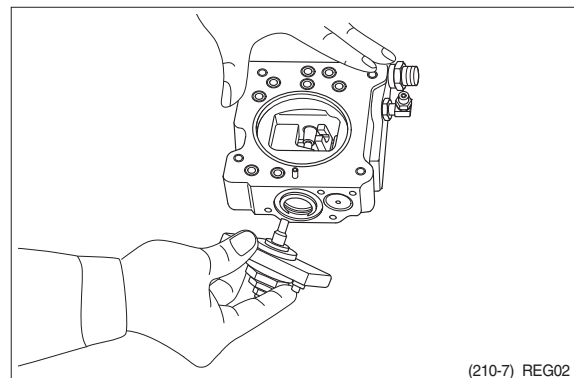

- (5) After removing cover (C, 629) subassembly, take out outer spring (625), inner spring (626) and spring seat (C, 624) from compensating section.

Then draw out adjusting ring (Q, 645), pilot spring (646) and spring seat (644) from pilot section.

- ※ Adjusting ring (Q,645) can easily be drawn out with M4 bolt.

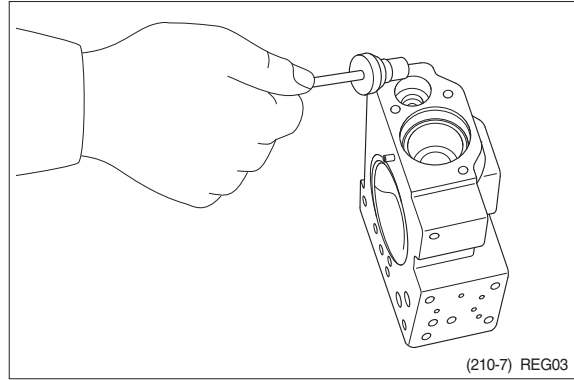

- (6) Remove hexagon socket head screws (436, 438) and remove pilot cover (641).

After removing pilot cover, take out set spring (655) from pilot section.

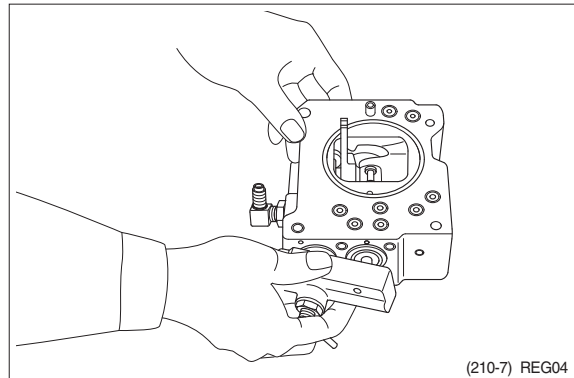

- (7) Remove snap ring (814) and take out spring seat (653), return spring (654) and sleeve (651).

- ※ Sleeve (651) is fitted with snap ring (836).
- ※ When removing snap ring (814), return spring (654) may pop out. Take care not to lose it.

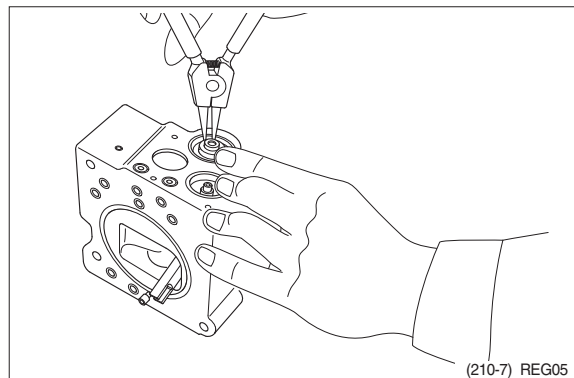

- (8) Remove prevention plug (616) and take out center plug (614) and adjusting plug (615).

- ※ Center plug (614) and adjusting plug (615) can easily be taken out with M6 bolt.

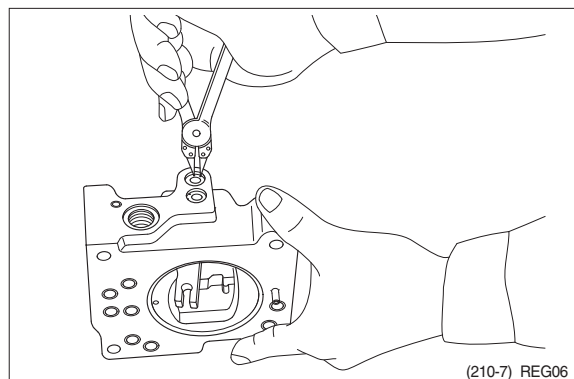

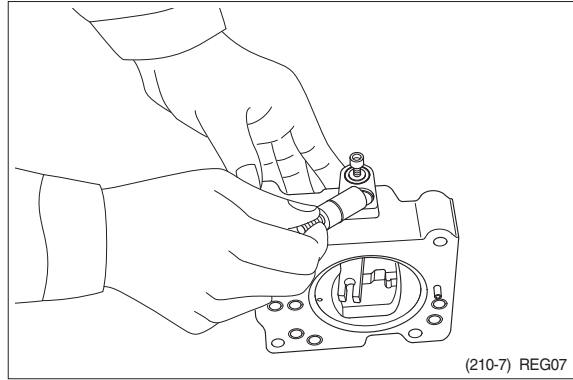

- (9) Remove lever (2, 613). Do not draw out pin (875).
※ Work will be promoted by using pincers or so on.

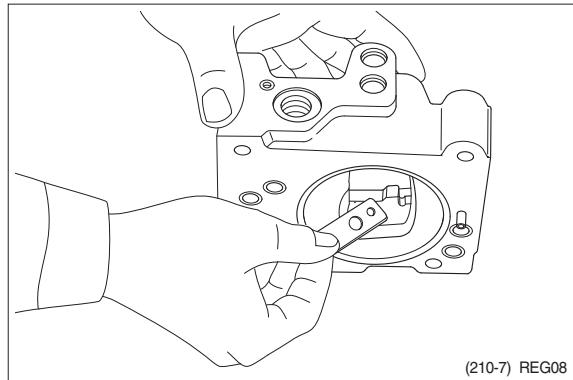

- (10) Draw out pin (874) and remove feedback lever (611).
Push out pin (874, 4 mm in dia.) from above with slender steel bar so that it may not interfere with lever (1, 612).

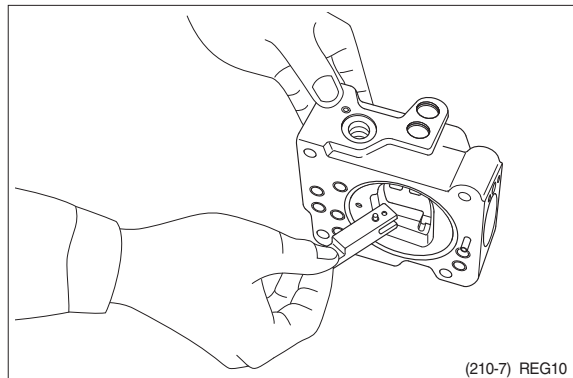
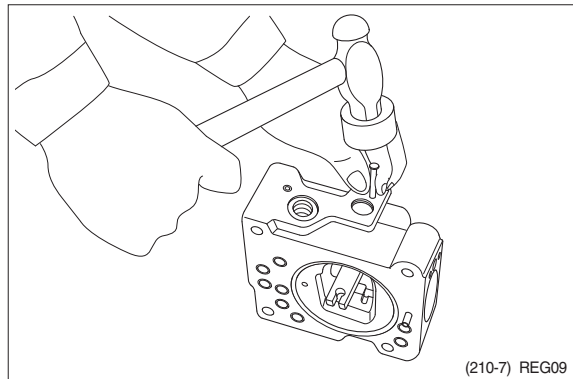

- (11) Remove lever (1, 612). Do not draw out pin (875).
 - (12) Draw out pilot piston (643) and spool (652).
 - (13) Draw out piston case (622), compensating piston (621) and compensating rod (623).
- ※ Piston case (622) can be taken out by pushing compensating rod (623) at opposite side of piston case.

This completes disassembly.

4) ASSEMBLY

(1) For assembly, reverse disassembly procedures, but pay attention to the following items.

- ① Always repair parts that were scored at disassembly.
- ② Get replacement parts ready beforehand.
Mixing of foreign matter will cause malfunction.
Therefore, wash parts well with cleaning oil, let them dry with jet air and handle them in clean place.
- ③ Always tighten bolts, plugs, etc. to their specified torques.
- ④ Do not fail to coat sliding surfaces with clean hydraulic oil before assembly.
- ⑤ Replace seals such as O-ring with new ones as a rule.

(2) Put compensating rod (623) into compensating hole of casing (601).

(3) Put pin force-fitted in lever (1, 612) into groove of compensating rod and fit lever (1) to pin force-fitted in casing.

(4) Fit spool (652) and sleeve (651) into hole in spool of casing.

- ※ Confirm that spool and sleeve slide smoothly in casing without binding.
- ※ Pay attention to orientation of spool.

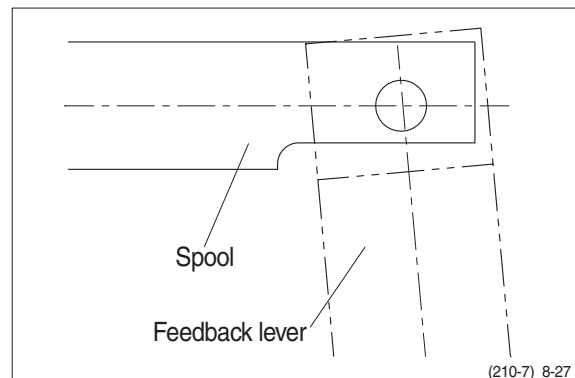

- (5) Fit feedback lever (611), matching its pin hole with pin hole in spool.
Then insert pin (874).
- ※ Insert pin in feedback lever a little to ease operation.
 - ※ Take care not to mistake direction of feedback lever.

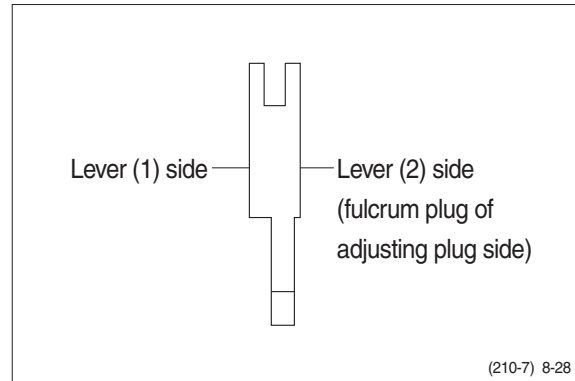

- (6) Put pilot piston (643) into pilot hole of casing.
- ※ Confirm that pilot piston slides smoothly without binding.
- (7) Put pin force-fitted in lever (2, 613) into groove of pilot piston.
Then fix lever (2).

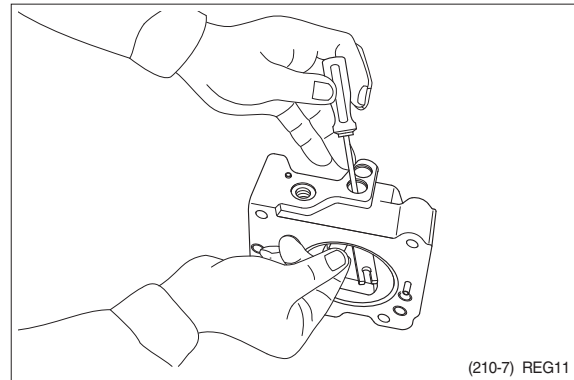

- (8) Fit center plug (614) so that pin force-fitted in center plug (614) can be put into pin hole of lever (2).
Then install prevention plug (858).
- (9) Insert adjusting plug (615) and fit locking ring.
- ※ Take care not to mistake inserting holes for fulcrum plug and adjusting plug.
- At this point in time move feedback lever to confirm that it has no large play and is free from binding.

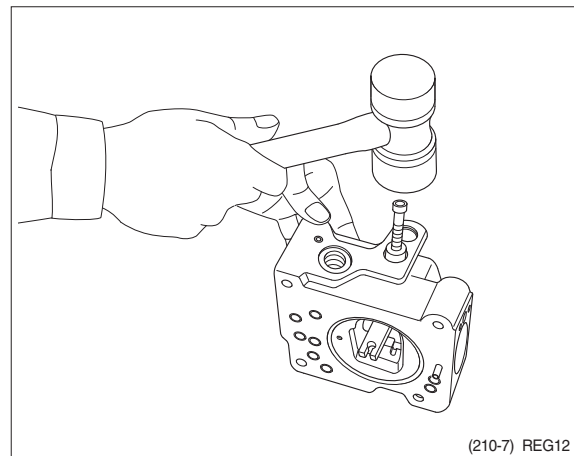

- (10) Fit return spring (654) and spring seat (653) into spool hole and attach snap ring (814).

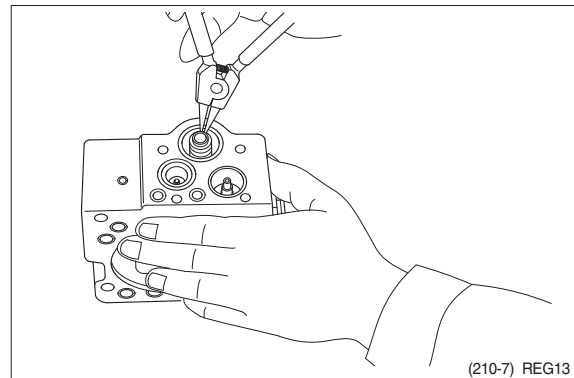

- (11) Fit set spring (655) to spool hole and put compensating piston (621) and piston case (622) into compensating hole.

Fit pilot cover (641) and tighten it with hexagonal socket head screws (437, 438).

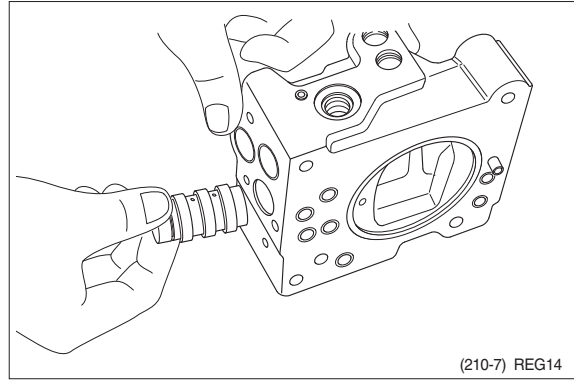

- (12) Put spring seat (644), pilot spring (646) and adjusting ring (Q, 645) into pilot hole. Then fix spring seat (624), inner spring (626) and outer spring (625) into compensating hole.

※ When fitting spring seat, take care not to mistake direction of spring seat.

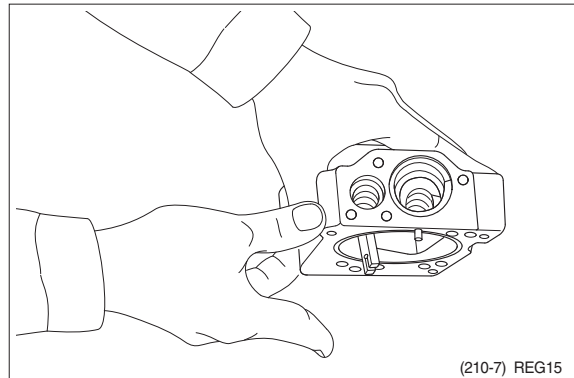

- (13) Install cover (C, 629) fitted with adjusting screws (628), adjusting ring (C, 627), lock nut (630), hexagon nut (801) and adjusting screw (924).

Then tighten them with hexagonal socket head screws (438).

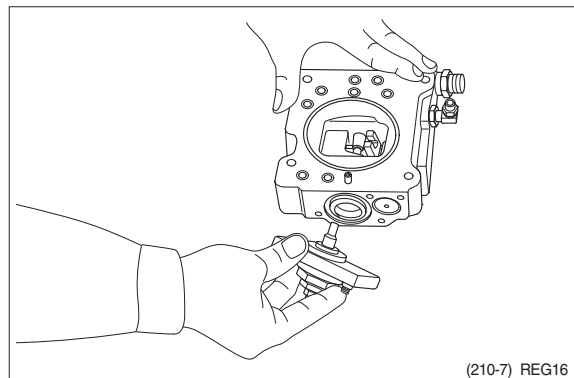

This completes assembly.

GROUP 4 MAIN CONTROL VALVE

1. REMOVAL AND INSTALL OF MOTOR

1) REMOVAL

- (1) Lower the work equipment to the ground and stop the engine.
- (2) Operate the control levers and pedals several times to release the remaining pressure in the hydraulic piping.
- (3) Loosen the breather slowly to release the pressure inside the hydraulic tank.
- ▲ **Escaping fluid under pressure can penetrate the skin causing serious injury.**
 - ※ When pipes and hoses are disconnected, the oil inside the piping will flow out, so catch it in oil pan.
- (4) Remove the wirings for the pressure sensor and so on.
- (5) Remove bolts and disconnect pipe.
- (6) Disconnect pilot line hoses.
- (7) Disconnect pilot piping.
- (8) Sling the control valve assembly and remove the control valve mounting bolt and bracket.
 - Weight : 140 kg (310 lb)
- (9) Remove the control valve assembly.
When removing the control valve assembly, check that all the piping have been disconnected.

2) INSTALL

- (1) Carry out installation in the reverse order to removal.
- (2) Bleed the air from below items.
 - ① Cylinder (Boom, arm, bucket)
 - ② Swing motor
 - ③ Travel motor※ See each item removal and install.
- (3) Confirm the hydraulic oil level and recheck the hydraulic oil leak or not.

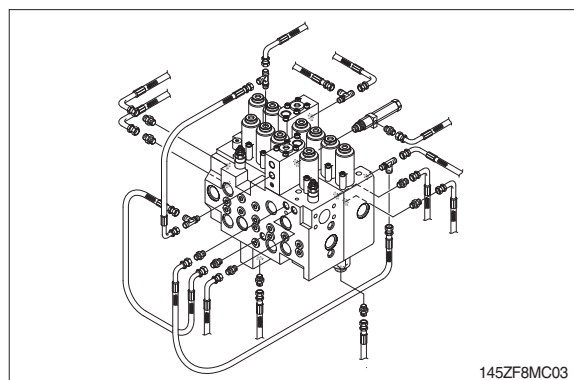
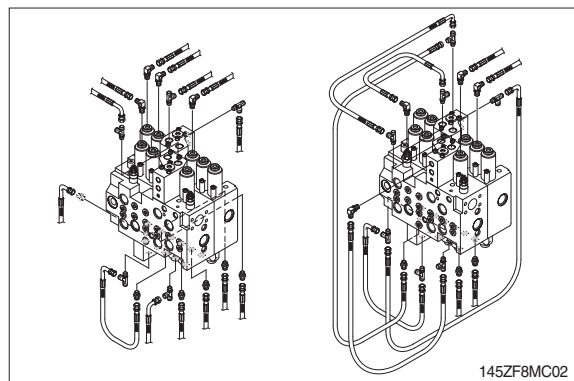
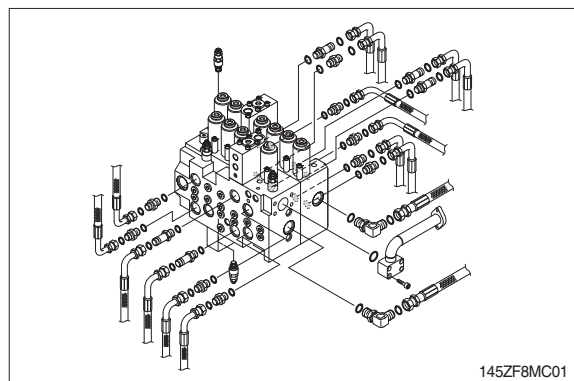

2. STRUCTURE (1/4)

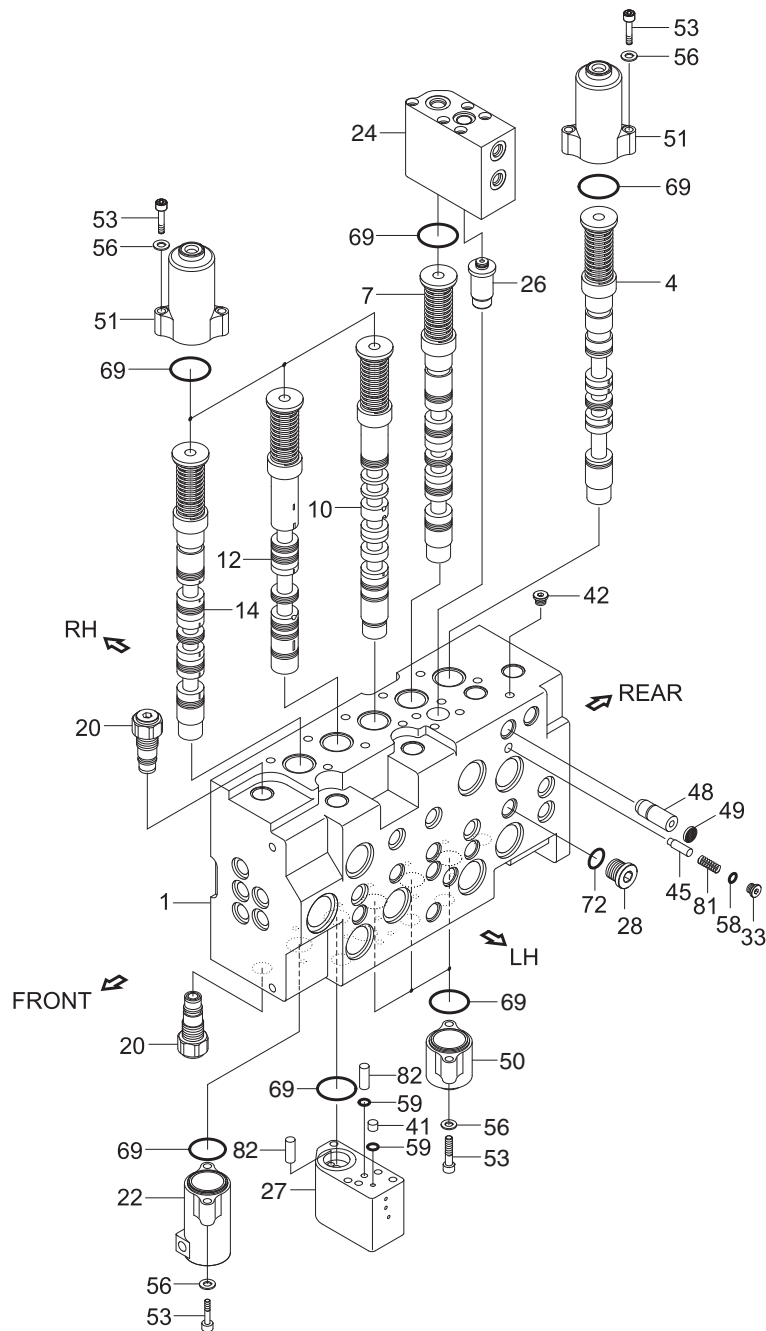

145LCR8MC04

1	Housing-P1	27	Regeneration block	53	Socket head bolt
4	Spool assy-travel LH	28	Plug	56	Plain washer
7	Spool assy-boom 1	33	Plug	58	O-ring
10	Spool assy-arm 2	41	Orifice	59	O-ring
12	Spool assy-arm regen	42	Plug	69	O-ring
14	Spool assy-bucket	45	Poppet	72	O-ring
20	Nega con relief valve	48	Orifice	81	Spring
22	Bucket stroke limiter	49	Coin type filter	82	Pin-regeneration
24	Holding valve kit A1	50	Pilot A cap		
26	Lock valve kit B	51	Pilot B1 cap		

STRUCTURE (2/4)

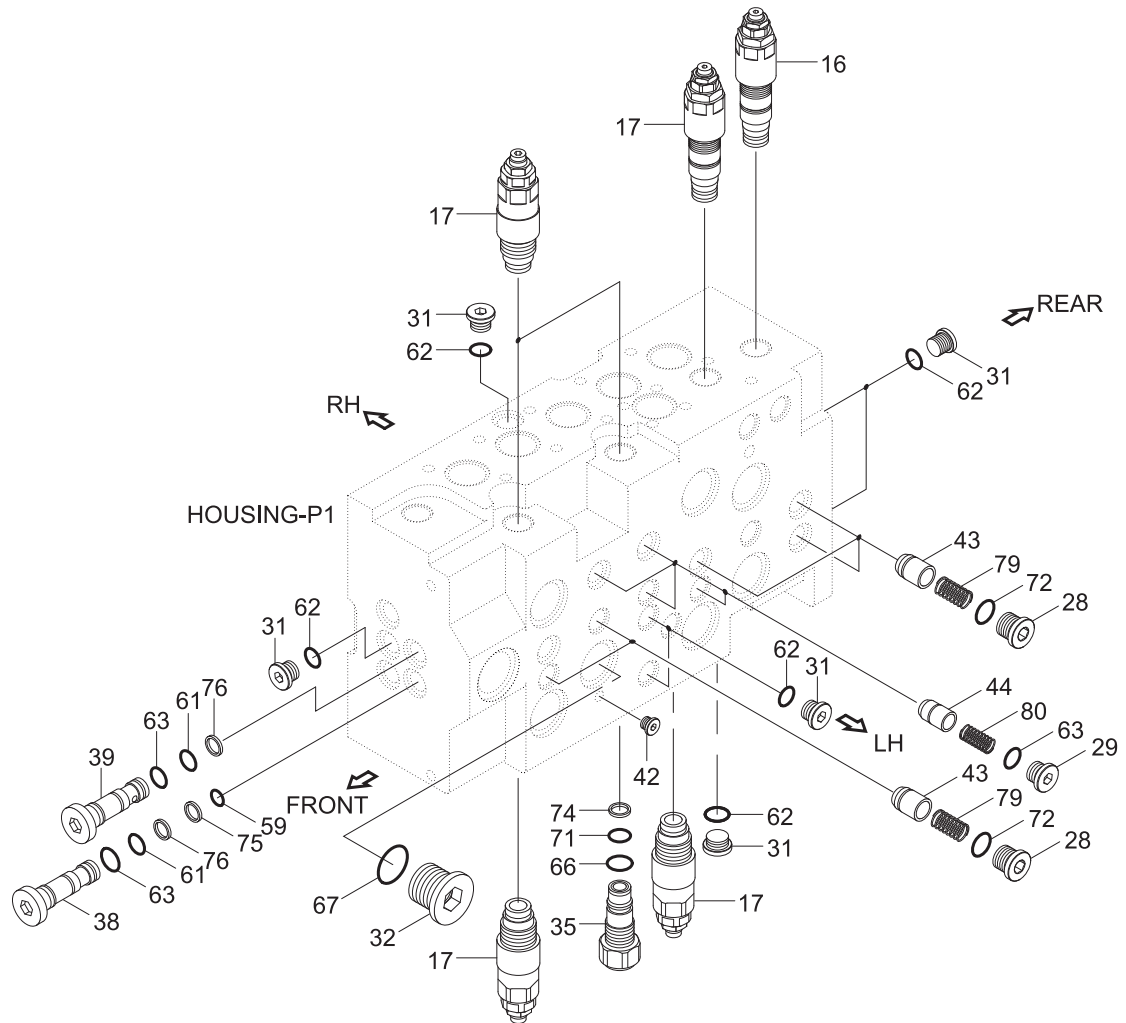

145LCR8MC05

- 16 Main relief valve
- 17 Overload relief valve
- 28 Plug
- 29 Plug
- 31 Plug
- 32 Plug
- 35 Plug
- 38 Plug
- 39 Plug

- 42 Plug
- 43 Poppet 1
- 44 Poppet 2
- 59 O-ring
- 61 O-ring
- 62 O-ring
- 63 O-ring
- 66 O-ring
- 67 O-ring

- 71 O-ring
- 72 O-ring
- 74 Back up ring
- 75 Back up ring
- 76 Back up ring
- 79 Spring
- 80 Spring

STRUCTURE (3/4)

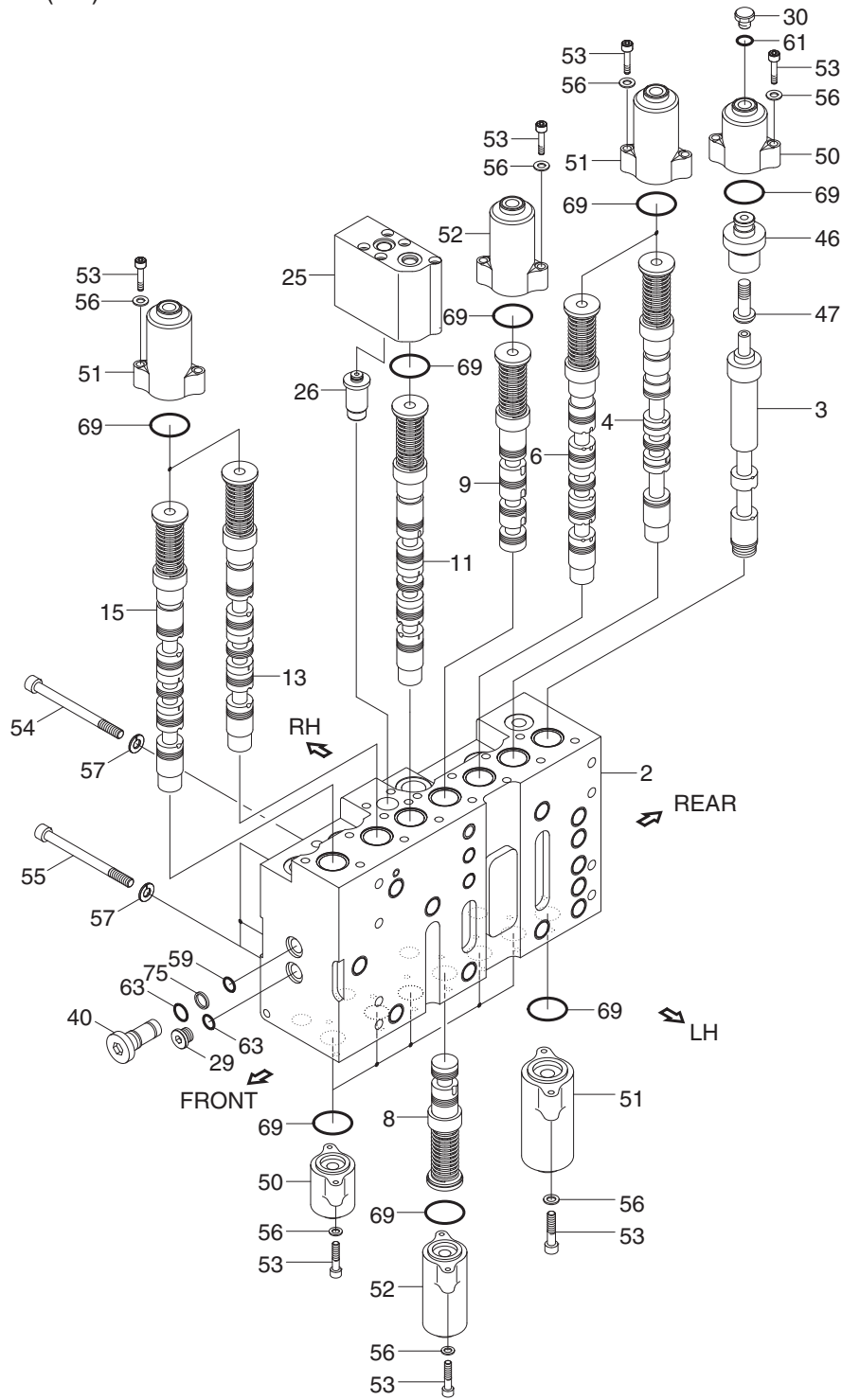

145LCR8MC06

- | | | | | | |
|----|---------------------------|----|------------------------|----|------------------|
| 2 | Housing-P2 | 26 | Lock valve kit-B | 54 | Socket head bolt |
| 3 | Spool assy | 29 | Plug | 55 | Socket head bolt |
| 4 | Spool assy-travel RH | 30 | Plug | 56 | Plain washer |
| 6 | Spool assy-swing | 40 | Plug | 57 | Spring washer |
| 8 | Spool assy-swing priority | 46 | Travel straight sleeve | 59 | O-ring |
| 9 | Spool assy-boom 2 | 47 | Travel straight piston | 61 | O-ring |
| 11 | Spool assy-arm 1 | 50 | Pilot A cap | 63 | O-ring |
| 13 | Spool assy-option B | 51 | Pilot B1 cap | 69 | O-ring |
| 15 | Spool assy-dozer | 52 | Pilot B2 cap | 75 | Back up ring |
| 25 | Holding valve kit A2 | 53 | Socket head bolt | | |

STRUCTURE (4/4)

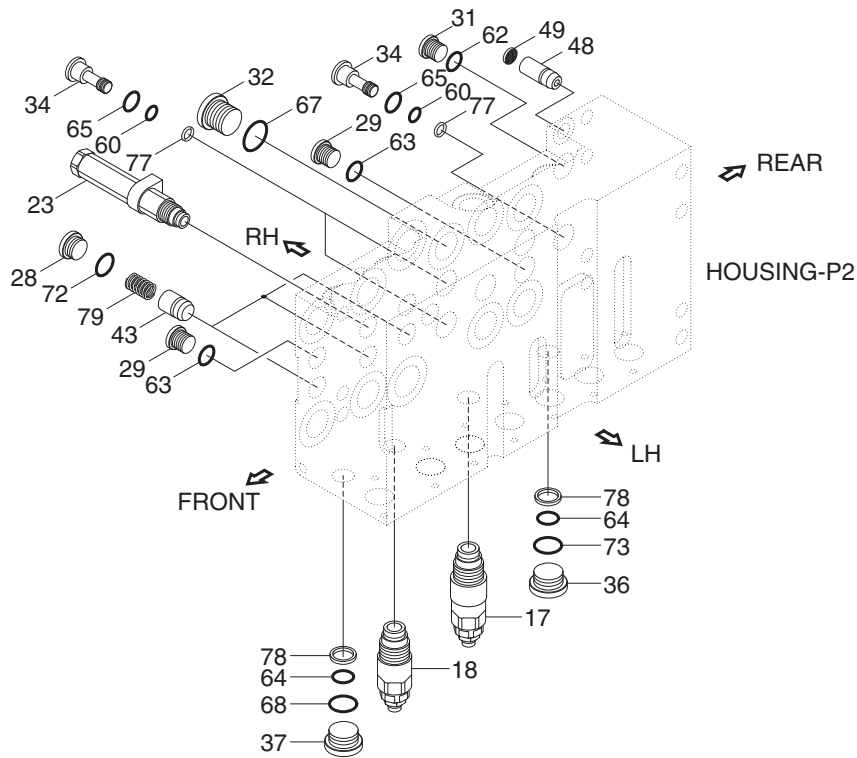
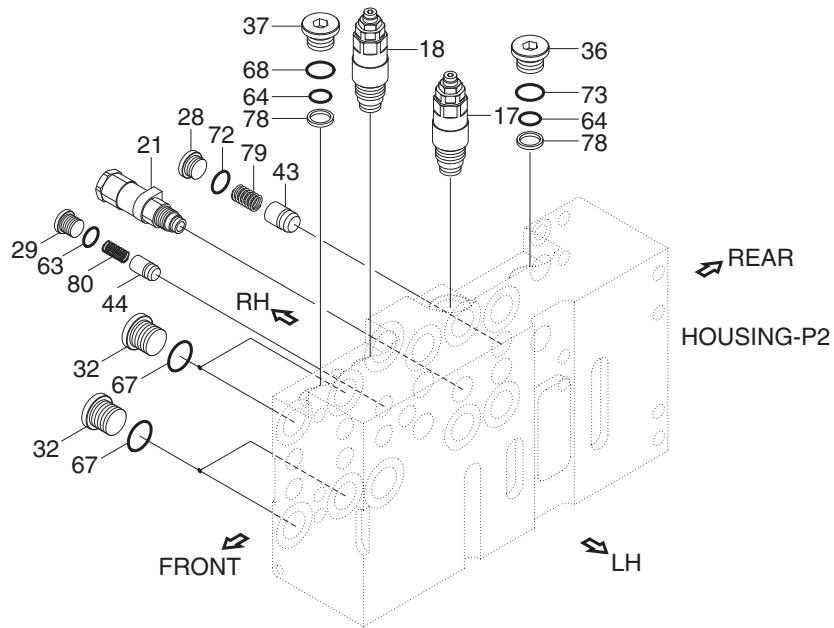

- | | | | | | |
|----|-----------------------|----|------------------|----|--------------|
| 17 | Overload relief valve | 37 | Plug | 67 | O-ring |
| 18 | Overload relief valve | 43 | Poppet 1 | 68 | O-ring |
| 21 | Swing logic valve | 44 | Poppet 2 | 72 | O-ring |
| 23 | ON/OFF valve-option | 48 | Orifice-signal | 73 | O-ring |
| 28 | Plug | 49 | Coin type filter | 77 | Back up ring |
| 29 | Plug | 60 | O-ring | 78 | Back up ring |
| 31 | Plug | 62 | O-ring | 79 | Spring |
| 32 | Plug | 63 | O-ring | 80 | Spring |
| 34 | Plug | 64 | O-ring | | |
| 36 | Plug | 65 | O-ring | | |

145LCR8MC07

3. DISASSEMBLY AND ASSEMBLY

1) GENERAL PRECAUTIONS

- (1) All hydraulic components are manufactured to a high precision. Consequently, before disassembling and assembling them, it is essential to select an especially clean place.
- (2) In handling a control valve, pay full attention to prevent dust, sand, etc. from entering into it.
- (3) When a control valve is to be removed from the machine, apply caps and masking seals to all ports. Before disassembling the valve, recheck that these caps and masking seals are fitted completely, and then clean the outside of the assembly. Use a proper bench for working. Spread paper or a rubber mat on the bench, and disassemble the valve on it.
- (4) Support the body section carefully when carrying or transferring the control valve. Do not lift by the exposed spool, end cover section etc.
- (5) After disassembling and assembling of the component it is desired to carry out various tests (for the relief characteristics, leakage, flow resistance, etc.), but hydraulic test equipment is necessary for these tests. Therefore, even when its disassembling can be carried out technically, do not disassemble such components that cannot be tested, adjusted, and so on. Additionally one should always prepare clean cleaning oil, hydraulic oil, grease, etc. beforehand.

2) TOOLS

Before disassembling the control valve, prepare the following tools beforehand.

Name of tool	Quantity	Size (mm)
Vice mounted on bench (soft jaws)	1 unit	
Hexagon wrench	Each 1 piece	5, 6, 10, 12 and 14
Socket wrench	Each 1 piece	27 and 32
Spanner	Each 1 piece	32 (main relief valve, overload relief valve, negative relief valve) 26 (holding valve)

3) DISASSEMBLY

(1) Disassembly of spools without holding valve

- ① Loosen hexagon socket head bolts with washer.
(hexagon wrench : 5 mm)
 - ② Remove the pilot cover.
- ※ Pay attention not to lose the O-ring under the pilot cover.
 - ③ Remove the spool assembly from the body by hand slightly.
- ※ When extracting each spool from its body, pay attention not to damage the body.
 - ※ When extracting each spool assembly, it must be extracted from spring side only.
 - ※ When any abnormal parts are found, replace it with completely new spool assembly.
 - ※ When disassembled, tag the components for identification so that they can be reassembled correctly.

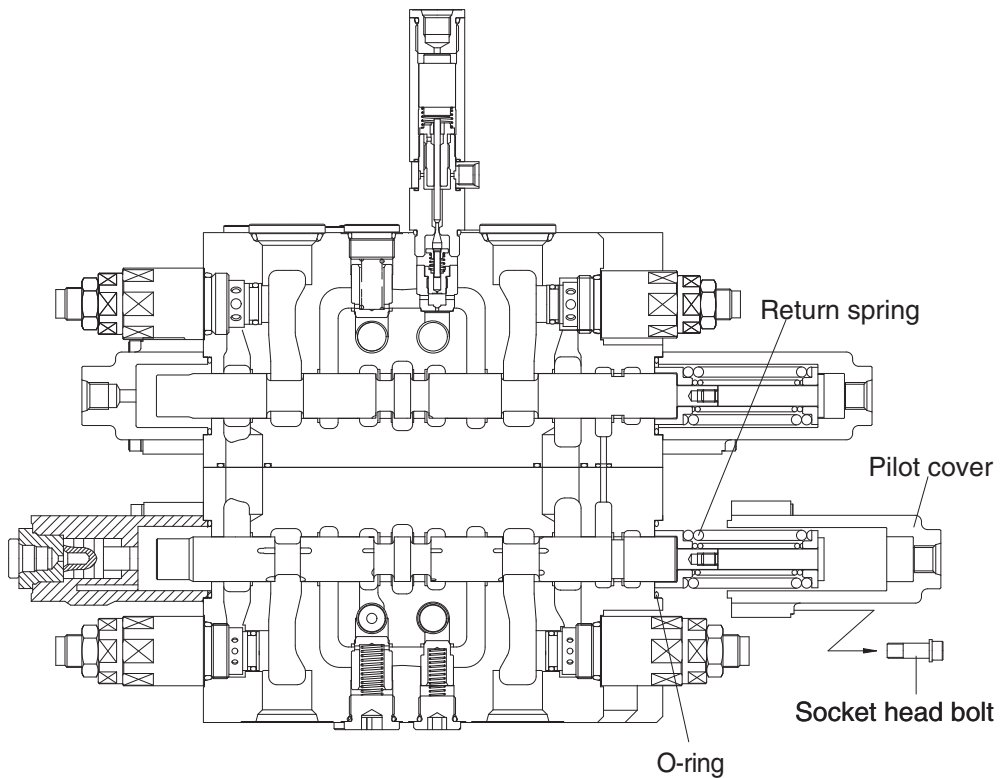

145LCR8MC10

(2) Disassembly of spools with holding valve (boom 1, Arm 1 spool)

- ① Loosen hexagon socket head bolts with washer.
(hexagon wrench : 5 mm)
- ② Remove the pilot cover with internal parts.
 - ※ Pay attention not to lose the O-ring and the poppet under the pilot cover.
 - ※ Pay attention not to damage the "piston A" under pilot cover.
- ③ Remove the spool assembly from the body by hand slightly.
 - ※ When extracting each spool from its body, pay attention not to damage the body.
 - ※ When extracting each spool assembly, it must be extracted from spring side only.
 - ※ When any abnormal parts are found, replace it with completely new spool assembly.
 - ※ When disassembled, tag the components for identification so that they can be reassembled correctly.

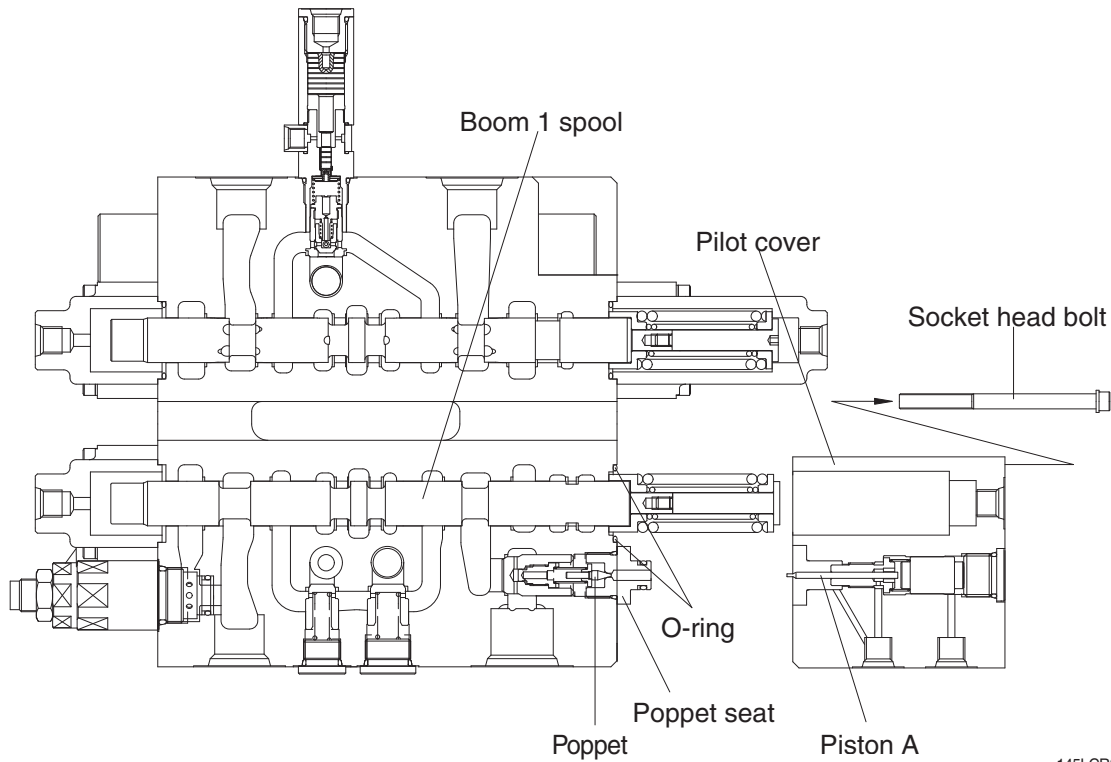

145LCR8MC11

(3) Disassembly of the holding valve

- ① Remove the pilot cover with the holding valve as described on previous page.
 - ※ Do not disassembled internal parts of the pilot cover.
- ② Loosen the poppet seat and remove the poppet, spring seat, spring and check.
(spanner : 26 mm)
 - ※ Pay attention not to lose the poppet.
 - ※ Do not disassembled internal parts of the check.

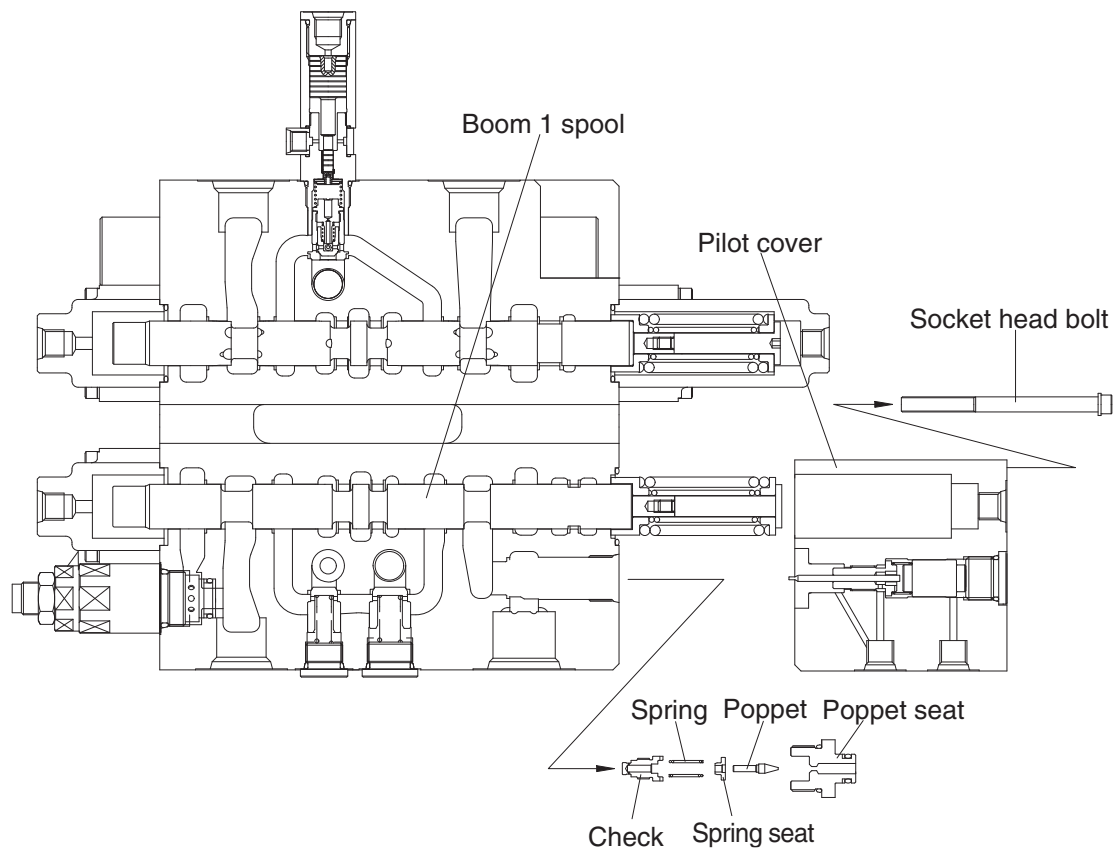

145LCR8MC12

(4) Disassembly of the load check valve and the negative relief valve

- ① The load check valve
 - a. Fix the body to suitable work bench.
 - ※ Pay attention not to damage the body.
 - b. Loosen the plug (hexagon wrench : 10 mm).
 - c. Remove the spring and the load check valve with pincers or magnet.
- ② The negative relief valve
 - a. Loosen the socket (spanner : 32 mm).
 - b. Remove the spring, spring holder, piston and negative control poppet.

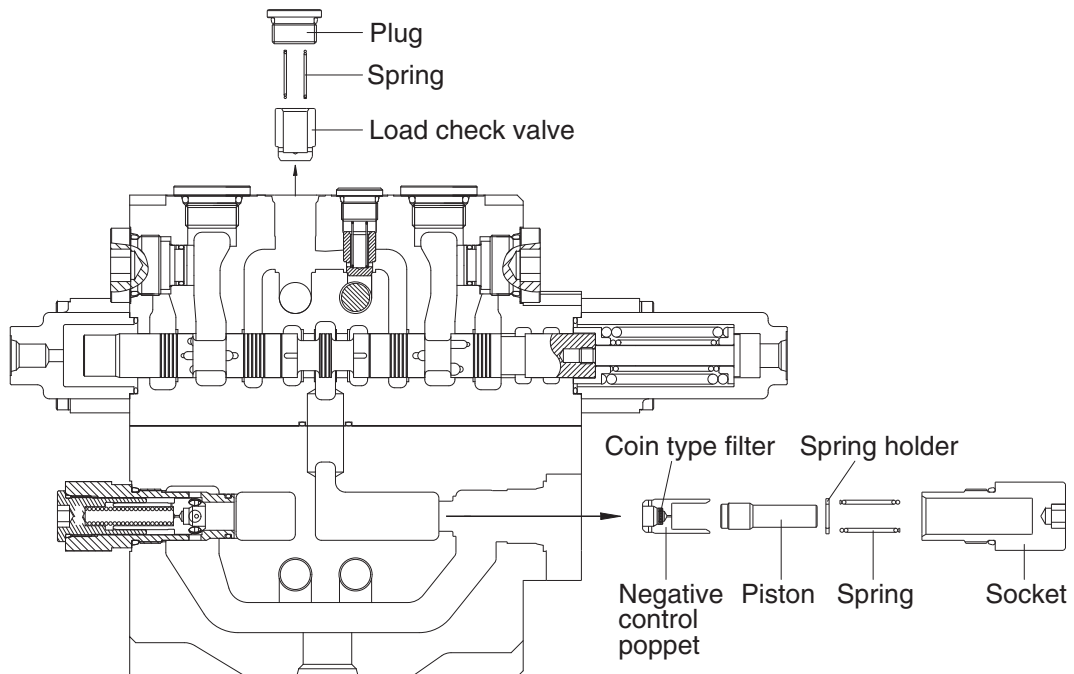

14W98MC13

(5) Disassembly of the main and overload relief valve

- ① Fix the body to suitable work bench.
 - ② Remove the main relief valve.
(spanner : 32 mm)
 - ③ Remove the overload relief valve.
(spanner : 32 mm)
- ※ When disassembled, tag the relief valve for identification so that they can be reassembled correctly.
 - ※ Pay attention not to damage seat face.
 - ※ When any abnormal parts are found, replace it with completely new relief valve assembly.

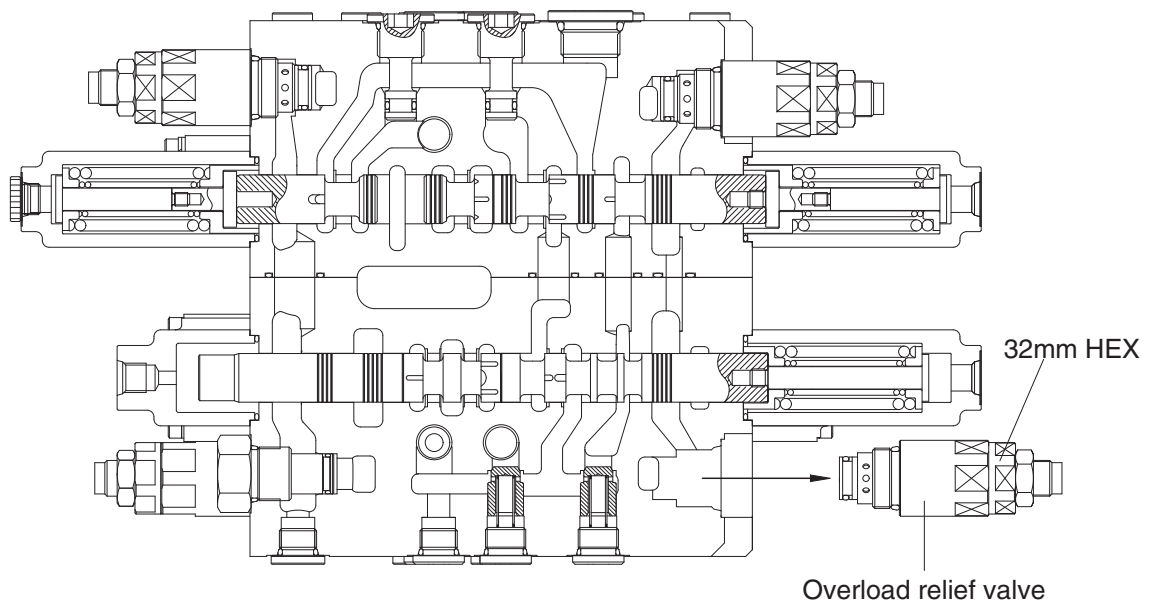
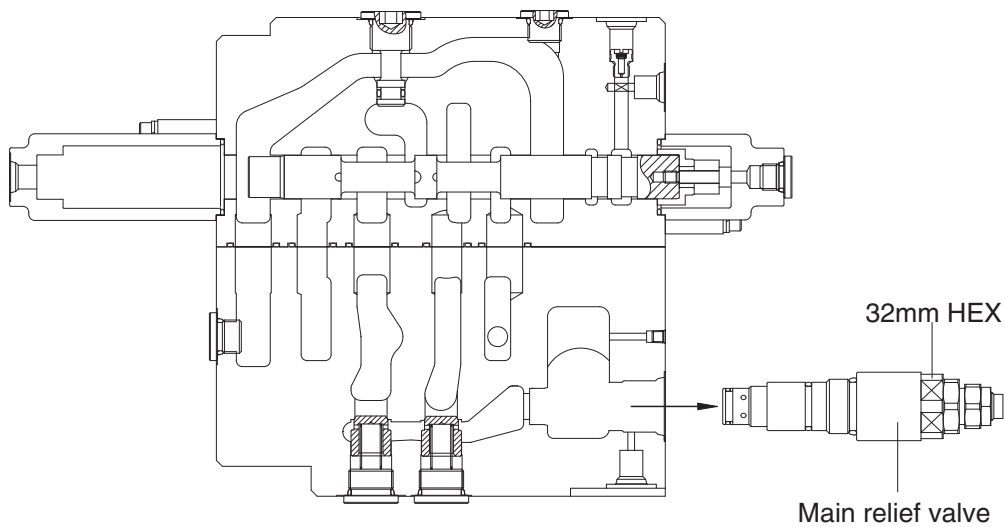

145LCR8MC14

(6) Inspection after disassembly

Clean all disassembled parts with clean mineral oil fully, and dry them with compressed air. Then, place them on clean papers or cloths for inspection.

① Control valve

- a. Check whole surfaces of all parts for burrs, scratches, notches and other defects.
- b. Confirm that seal groove faces of body and block are smooth and free of dust, dent, rust etc.
- c. Correct dents and damages and check seat faces within the body, if any, by lapping.
※ Pay careful attention not to leave any lapping agent within the body.
- d. Confirm that all sliding and fitting parts can be moved manually and that all grooves and paths are free foreign matter.
- e. If any spring is broken or deformed, replace it with new one.
- f. When a relief valve does not function properly, repair it, following it's the prescribed disassembly and assembly procedures.
- g. Replace all seals and O-rings with new ones.

② Relief valve

- a. Confirm that all seat faces at ends of all poppets and seats are free of defects and show uniform and consistent contact faces.
- b. Confirm manually that main poppet and seat can slide lightly and smoothly.
- c. Confirm that outside face of main poppet and inside face of seat are free from scratches and so on.
- d. Confirm that springs are free from breakage, deformation, and wear.
- e. Confirm that orifices of main poppet and seat section are not clogged with foreign matter.
- f. Replace all O-rings with new ones.
- g. When any light damage is found in above inspections, correct it by lapping.
- h. When any abnormal part is found, replace it with a completely new relief valve assembly.

4) ASSEMBLY

(1) General precaution

- ① In this assembly section, explanation only is shown.
For further understanding, please refer to the figures shown in the previous structure & disassembly section.
- ② Pay close attention to keeping all seals free from handling damage and inspect carefully for damage before using them.
- ③ Apply clean grease or hydraulic oil to the seal so as to ensure it is fully lubricated before assembly.
Do not stretch seals so much as to deform them permanently.
- ④ In fitting O-rings, pay close attention not to roll them into their final position in addition, a twisted
- ⑤ O-ring cannot easily untwist itself naturally and could thereby cause inadequate sealing and thereby both internal and external oil leakage.
- ⑥ Tighten fitting bolts for all sections with a torque wrench adjusted to the respective tightening torque.
- ⑦ Do not reuse removed O-rings and seals.

(2) Load check valve

- ① Assemble the load check valve and spring.
- ② Put O-rings on to plug.
- ③ Tighten plug to the specified torque.
 - Hexagon wrench : 10 mm
 - Tightening torque : 6~7 kgf · m (43.4~50.6 lbf · ft)

(3) Negative control relief valve

- ① Assemble the nega-con poppet, piston, spring holder and spring together into body.
- ② Put O-ring on to plug and tighten the latter to its specified torque.
 - Hexagon wrench : 12 mm
 - Tightening torque : 8~9 kgf · m (57.8~65.1 lbf · ft)

(4) Main relief, overload relief valves

Install main relief valve, overload relief valve into the body and tighten to the specified torque.

Component	Tools	Tightening torque	
		kgf · m	lbf · ft
Main relief valve	Spanner 32 mm	8~9	57.8~65.1
Overload relief valve	Spanner 32 mm	8~9	57.8~65.1

(5) Main spools

- ① Carefully insert the previously assembled spool assemblies into their respective bores within of body.
 - ※ Fit spool assemblies into body carefully and slowly. Do not under any circumstances push them forcibly in.

(6) Pilot covers

- ① Fit spool covers to the non-spring assembly end of the spool, and tighten the hexagonal socket head bolts to the specified torque.
 - Hexagon wrench : 5 mm
 - Tightening torque : 1.0~1.1 kgf · m (7.2~7.9 lbf · ft)
- ※ Confirm that O-rings have been fitted.
- ② Fit spring covers to the spring end for the spools, and tighten hexagon socket head bolts to the specified torque.
 - Hexagon wrench : 5mm
 - Tightening torque : 1.0~1.1 kgf·m (7.2~7.9 lbf·ft)
- ※ Confirm that O-rings have been fitted.

(7) Holding valves

- ① Assemble the check, spring seat and poppet together into body.
- ② Tighten the poppet seat to the specified torque.
 - Spanner : 26 mm
 - Tightening torque : 6~7 kgf · m (43.4~50.6 lbf · ft)
- ③ Fit the "piston A" under pilot cover with internal parts into hole on the poppet seat.
- ④ Tighten hexagon socket head bolt to specified torque.
 - Hexagon wrench : 5mm
 - Tightening torque : 1.0~1.1 kgf · m (7.2~7.9 lbf · ft)

GROUP 5 SWING DEVICE (TYPE 1)

1. REMOVAL AND INSTALL OF MOTOR

1) REMOVAL

- (1) Lower the work equipment to the ground and stop the engine.
- (2) Operate the control levers and pedals several times to release the remaining pressure in the hydraulic piping.
- (3) Loosen the breather slowly to release the pressure inside the hydraulic tank.

▲ Escaping fluid under pressure can penetrate the skin causing serious injury.

※ When pipes and hoses are disconnected, the oil inside the piping will flow out, so catch it in oil pan.

- (4) Disconnect hose assembly (2).
- (5) Disconnect pilot line hoses (3, 4, 5, 6, 7, 8).
- (6) Sling the swing motor assembly (1) and remove the swing motor mounting socket bolts (9).

· Motor device weight : 34 kg (75 lb)

- (7) Remove the swing motor assembly.
※ When removing the swing motor assembly, check that all the piping have been disconnected.

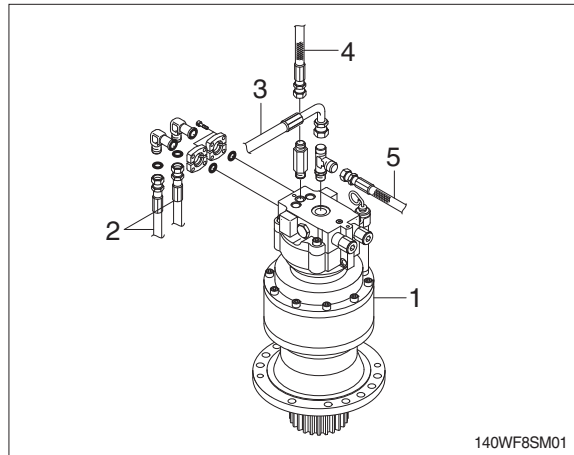

2) INSTALL

- (1) Carry out installation in the reverse order to removal.
- (2) Bleed the air from the swing motor.
 - ① Remove the air vent plug.
 - ② Pour in hydraulic oil until it overflows from the port.
 - ③ Tighten plug lightly.
 - ④ Start the engine, run at low idling and check oil come out from plug.
 - ⑤ Tighten plug fully.
- (3) Confirm the hydraulic oil level and check the hydraulic oil leak or not.

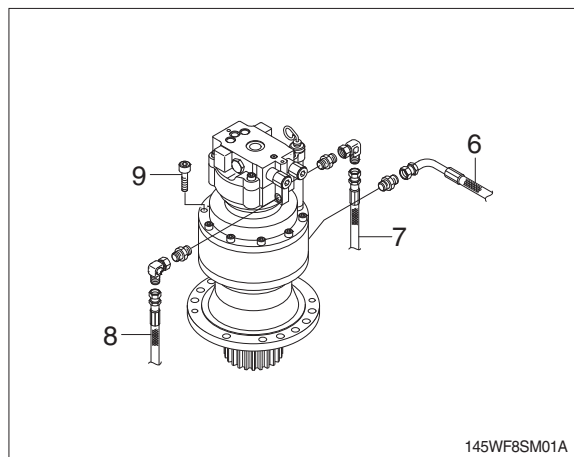

2. DISASSEMBLY AND ASSEMBLY OF SWING MOTOR

1) STRUCTURE

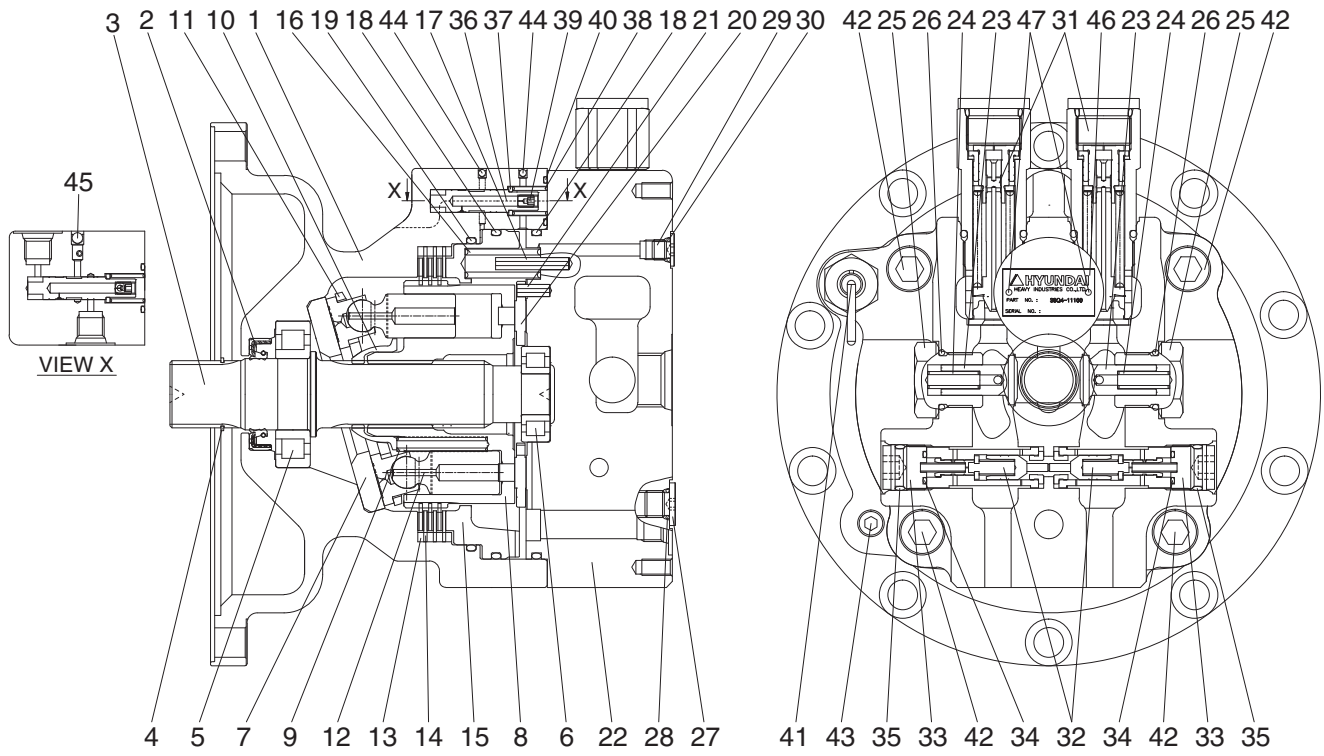

125LCR2SM22

1	Casing	17	Spring pin	33	Plug
2	Oil seal	18	O-ring	34	O-ring
3	Shaft	19	O-ring	35	O-ring
4	Snap ring	20	Valve plate	36	Time delay valve spool
5	Roller bearing	21	Spring pin	37	Spring seat
6	Roller bearing	22	Valve casing	38	Spring
7	Swash plate	23	Check valve	39	Restrictor
8	Cylinder block	24	Spring	40	O-ring
9	Spring	25	Plug	41	Level gauge assy
10	Ball guide	26	O-ring	42	Socket bolt
11	Retainer plate	27	Plug	43	Plug
12	Piston assy	28	O-ring	44	Expander
13	Friction plate	29	Plug	45	Expander
14	Separate plate	30	O-ring	46	Name plate
15	Parking piston	31	Relief valve assy	47	Rivet
16	Spring	32	Anti-rotating valve assy		

2) DISASSEMBLY

- (1) For easy assembly, put motor on worktable with the spline side of shaft (3) facing downwards.
 - ※ Lay rubber plate on worktable and take care not to damage the components.



- (2) Remove snap ring (4) using snap ring plier.



- (3) Disassemble level gauge assembly (41) using pipe wrench.



- (4) Disassemble two sets of relief valve assembly (31) using 36 mm socket wrench.



- (5) Unscrew socket bolt (42) (4EA) using 12 mm hexagon wrench.



125LCR8SM07

- (6) Remove valve plate (20) from valve casing.
※ Take care not to drop the valve plate (20).

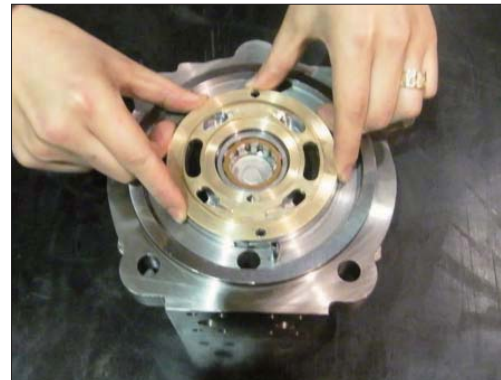

125LCR8SM08

- (7) Remove O-ring (18) from valve casing.



125LCR8SM09

- (8) Remove plug (33) using 10 mm hexagon wrench and take out anti-rotating valve assembly (32).
(same for the set on opposite side)

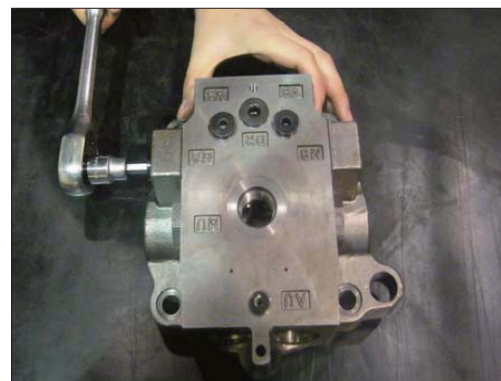

125LCR8SM10

(9) Remove plug (29) (1EA), plug (27) (2EA) using 4 mm, 6 mm hexagon wrench.

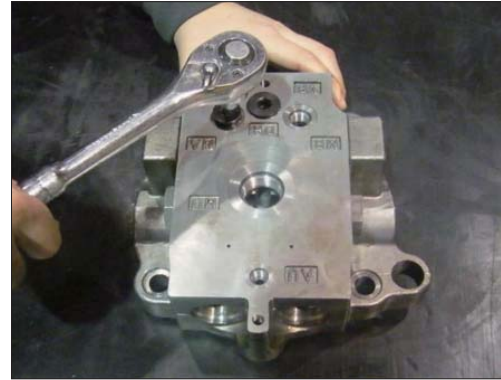

125LCR8SM11

(10) Remove plug (25) using 32 mm socket wrench and separate spring ; spring (24) and check valve (23). (same for the set on opposite side)



125LCR8SM12

(11) Separate each one of O-ring (40) and spring (38).

- ※ Do not lose spring.
- ※ Do not mix spring with other springs.



125LCR8SM13

(12) Remove spool (36) and spring seat (37).

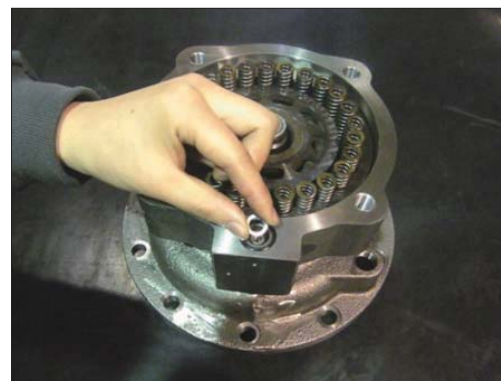

125LCR8SM14

(13) Remove spring (16) (24EA) from parking piston.



125LCR8SM15

(14) Disassemble parking piston (15) from casing using air gun.



125LCR8SM16

(15) Lay casing down horizontally and remove cylinder block assembly from shaft. And remove all friction plate (13) and separator plate (14).



125LCR8SM17

(16) Separate piston assembly (12), ball guide (10), retainer plate (11) and spring (9).



125LCR8SM18

(17) Remove O-ring (19) from casing.



125LCR6SM19

(18) Use a magnet to separate swash plate (7) from casing.

- ※ Sliding surface should be carefully treated to avoid scratches and damage.



125LCR6SM20

(19) Disassemble shaft (3) and cylindrical roller bearing (5).

- ※ Do not remove cylindrical roller bearing (5) unless malfunction is detected, since it is mounted by shrink fit.



125LCR6SM21

(20) Turn casing (1) upside down and remove oil seal (2) using jig.



125LCR6SM22

3) ASSEMBLY

※ Even though assembly is accomplished by reversing disassembly steps, be careful of the following.

- ① Repair the damaged part when disassembling and prepare parts for exchange in advance.
- ② All parts should be cleaned with cleaner, dried with compressed air.
- ③ Sliding surface, O-ring, bearing and oil seal should be lubricated with clean hydraulic oil, prior to final assembly.
- ④ Replacement of O-ring and oil seal with new parts is generally recommended.
- ⑤ Use a torque wrench to make sure that assembly fasteners are tightened to specified values.
- ⑥ When assembling bolt, spread loctite.

(1) Put casing (1) on worktable.

Press oil seal (2) using oil seal jig, until it reach the bottom.

※ Spread grease on external diameter of oil seal.



125LCR8SM23

(2) Mount cylindrical roller bearing (5, 6) on shaft (3) using shrink fitting method.



125LCR8SM24

- (3) Assemble shaft assembly in casing using urethane hammer.
※ Take care not to damage oil seal.



125LCR8SM25

- (4) Insert swash plate (7).
※ Take care not to damage sliding surface.



125LCR8SM26

- (5) After applying grease on O-ring (19), insert O-ring in casing (1).



125LCR8SM27

- (6) Assemble spring (9) (9EA) in cylinder block (8).

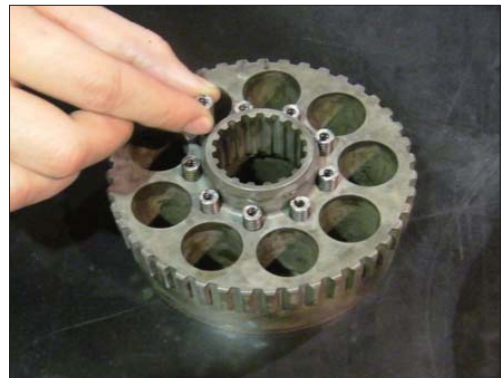

125LCR8SM28

- (7) Assemble ball guide (10) in cylinder block.
※ Take care not to damage sliding surface of cylinder block.



125LCR8SM29

- (8) Insert piston assembly (12) in retainer plate (11).
※ Do not mix piston with other piston (9EA/1set).
※ Spread sufficient amount of hydraulic oil on piston assembly.



125LCR8SM30

- (9) Place all 9 pistons simultaneously into the holes of cylinder block.
※ Take care not to damage sliding surface.



125LCR8SM31

- (10) Lay casing down horizontally and put cylinder block assembly in casing.
※ Check whether cylinder block assembly rotates smoothly.



125LCR8SM32

(11) Put friction plate (13) in casing.



125LCR8SM33

(12) Put separator plate (14) in casing.
※ Put friction plate and separator plate alternately.

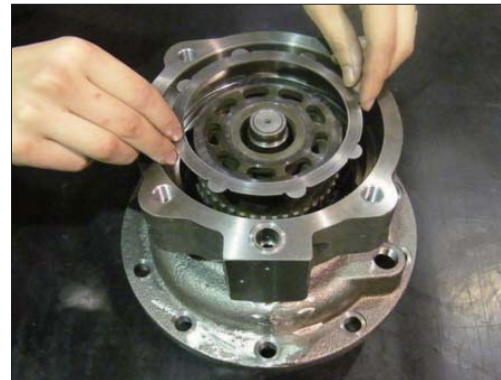

125LCR8SM34

(13) Assemble O-ring (18) in parking piston (15).
※ Apply grease on O-ring.



125LCR8SM35

(14) Assemble parking piston (15) in casing using jig.
※ Pay attention to the hole location of parking piston.



125LCR8SM36

(15) Put spring (16) (24EA) in each hole of parking piston.



125LCR8SM37

(16) Assemble restrictor (39) in spool (36).
※ Spread loctite #242.



125LCR8SM38

(17) Place spool in casing.

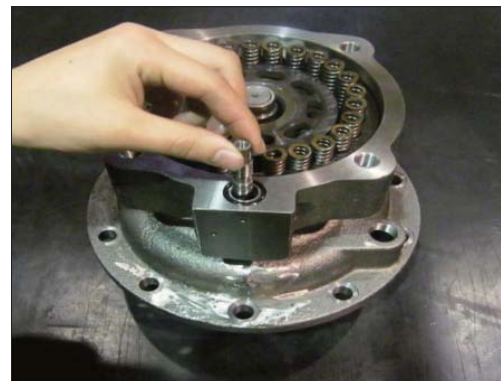

125LCR8SM39

(18) Assemble spring (38) & spring seat (37) in casing.

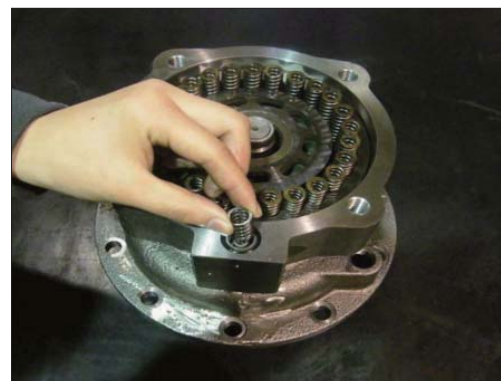

125LCR8SM40

(19) Assemble plug (27) using 6 mm hexagon wrench.

※ Tightening torque : 4.5 kgf · m (32.5 lbf · ft)



125LCR8SM41

(20) Assemble plug (29) using 4 mm hexagon wrench.

※ Tightening torque : 3 kgf · m (21.7 lbf · ft)

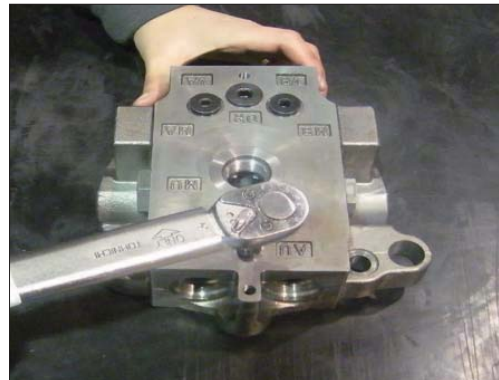

125LCR8SM42

(21) Assemble anti-rotating valve assembly (32) in valve casing.

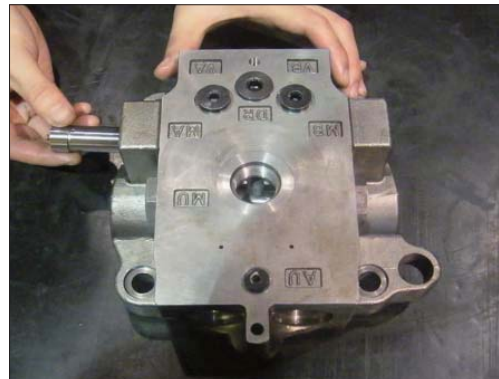

125LCR8SM43

(22) Assemble plug (33) using 32 mm hexagon wrench.

※ Tightening torque : 10 kgf · m (72.3 lbf · ft)

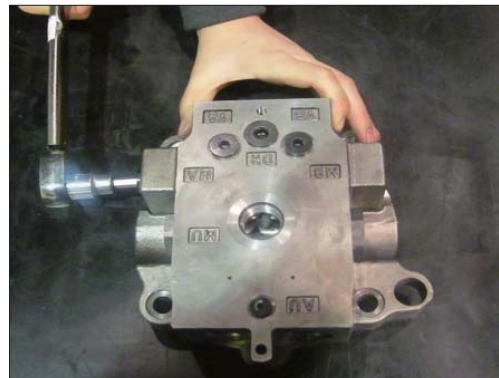

125LCR8SM44

(23) Caulk check valve (23) using jig. (same for the set on opposite side)



125LCR8SM45

(24) Assemble spring (24), plug (25). (in that order)
(same for the set on opposite side)
※ Tightening torque : 15 kgf · m (108 lbf · ft)



125LCR8SM46

(25) Assemble spring pin (21) in valve casing using jig.



125LCR8SM47

(26) Assemble O-ring (18) & cylindrical roller bearing (6) in valve casing.
※ Use jig (press fit or cold shrink fit).



125LCR8SM48

(27) Apply grease on steel side of valve plate (20) to prevent plate from sliding.

Assemble valve plate with the copper side facing upwards.

- ※ Pay attention to the assembly direction.
- ※ Take care not to damage sliding surface.



125LCR8SM49

(28) Assemble valve casing by matching its holes and pins of casing and parking piston. And tighten bolt; socket (42) (4EA) using 12 mm hexagon wrench.

- ※ Tightening torque : 17.5 kgf · m (127 lbf · ft)
- ※ Make sure valve plate stays in place.
- ※ When tightening bolts, make sure mating surfaces between casing and valve casing maintain parallel to each other.

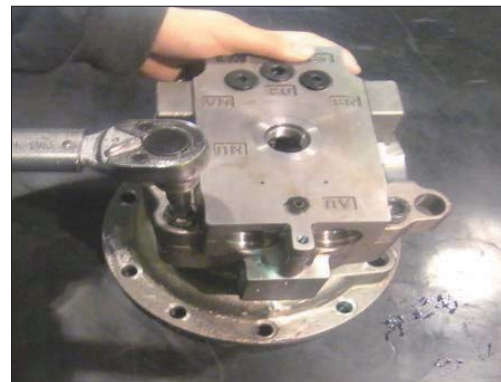

125LCR8SM50

(29) Assemble relief valve assembly (31) using 36 mm socket wrench in valve casing.

- ※ Spread grease on O-ring part of relief valve assembly.
- ※ Tightening torque : 18 kgf · m (130 lbf · ft)



125LCR8SM51

(30) Assemble snap ring (4) in shaft by using snap ring plier.



125LCR8SM52

(31) Wrap teflon tape 2 or 3 times around the tap part of level gauge assembly (41).
And assemble it using pipe wrench.

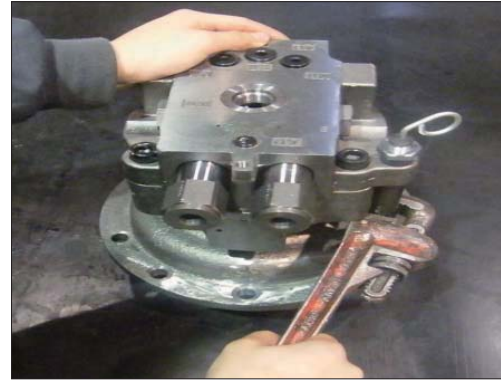

125LCR6SM53

3. REMOVAL AND INSTALL OF REDUCTION GEAR

1) REMOVAL

- (1) Remove the swing motor assembly.
For details, see removal of swing motor assembly.
- (2) Sling reduction gear assembly (1) and remove mounting bolts (2).
- (3) Remove the reduction gear assembly.
 - Reduction gear device weight : 75 kg
(165 lb)



2) INSTALL

- (1) Carry out installation in the reverse order to removal.
 - Tightening torque : 17.5 kgf · m
(126 lbf · ft)

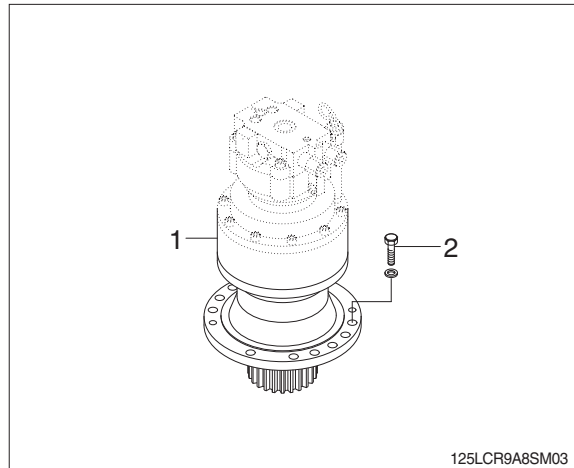

4. DISASSEMBLY AND ASSEMBLY OF REDUCTION GEAR

1) STRUCTURE

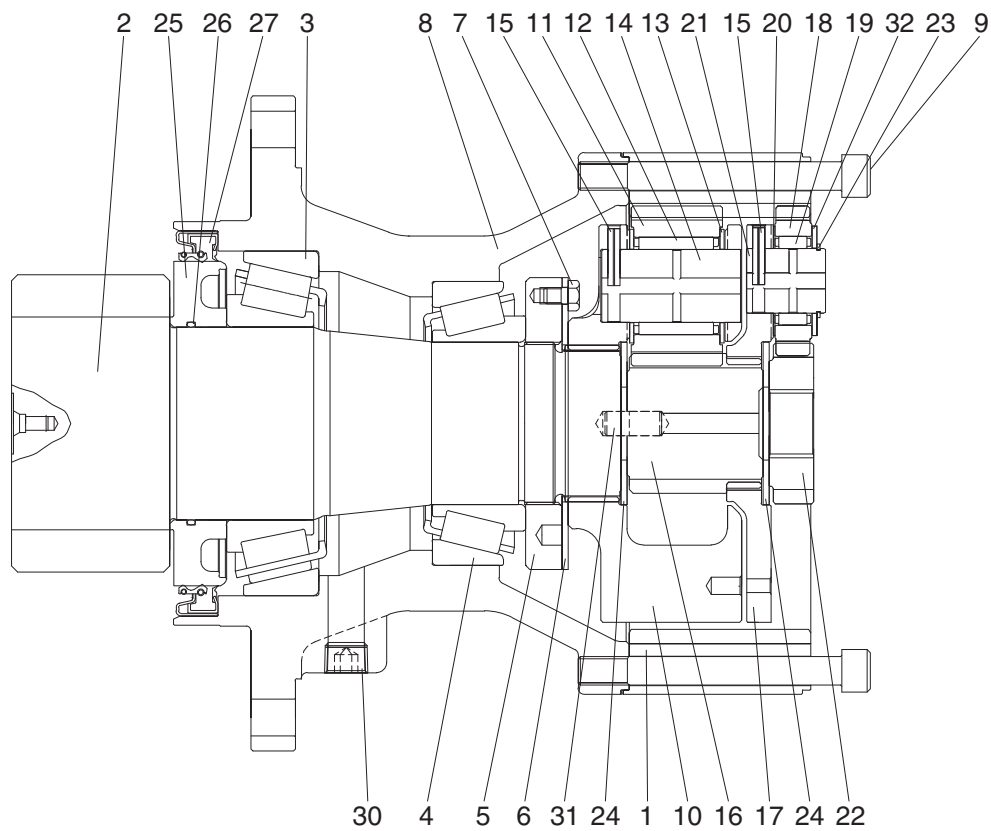

125LCR2SM23

1	Ring gear	11	Planetary gear No. 2	21	Carrier pin No. 1
2	Drive shaft	12	Needle bearing No. 2	22	Sun gear No. 1
3	Bearing	13	Thrust washer No. 2	23	Snap ring
4	Bearing	14	Carrier pin No. 2	24	Thrust plate
5	Ring nut	15	Spring pin	25	Sleeve
6	Lock plate	16	Sun gear No. 2	26	O-ring
7	Hexagon bolt	17	Carrier No. 1	27	Oil seal
8	Casing	18	Planetary gear No. 1	30	Plug
9	Socket bolt	19	Needle bearing No. 1	31	Parallel pin
10	Carrier No. 2	20	Thrust washer No. 1	32	Thrust washer No. 1

2) DISASSEMBLY

- (1) Remove the swing motor, and then place swing reduction gear on the bench.



125LCR8SM60

- (2) Disassemble sun gear No.1 (22).



125LCR8SM61

- (3) Disassemble carrier No.1 sub assembly.



125LCR8SM62

Carrier No.1 sub assy disassembly

- (4) Put carrier No.1 sub assembly on the bench, then remove the snap ring (23).



125LCR8SM63

- (5) Disassemble thrust washer No.1 (upper)
(32).(3 pcs)



125LCR8SM64

- (6) Disassemble planetary gear No.1 (18).
(3 pcs)



125LCR8SM65

- (7) Disassemble thrust plate (24).



125LCR8SM66

- (8) Disassemble needle bearing No.1 (19).
(3 pcs)



125LCR8SM67

(9) Disassemble thrust washer No.1 (lower) (20).
(3 pcs)



125LCR8SM68

(10) After placing spring pin (15) to center of carrier pin No.1 (21) with a jig, disassemble it.
(3 pcs)

※ Do not reuse spring pin, carrier and carrier pin.



125LCR8SM69

(11) Disassemble sun gear No.2 (16).



125LCR8SM70

(12) Disassemble carrier No.2 sub assembly.



125LCR8SM71

Carrier No.2 sub assy disassembly

(13) After placing spring pin (15) to center of carrier pin No.2 (14) with a press machine, disassemble it.(3 pcs)

※ Do not reuse spring pin.



125LCR8SM72

(14) Disassemble planetary gear No.2.(3 pcs)



125LCR8SM73

(15) Disassemble thrust plate (24).



125LCR8SM74

(16) Disassemble thrust washer No.2 (13).(6 pcs)



125LCR8SM75

(17) Disassemble needle bearing No.2 (12).
(3 pcs)



125LCR8SM76

(18) Separate ring gear (1) from casing (8).



125LCR8SM77

(19) Loosen a bolt (7) (4 pcs), and disassemble lock plate (6).



125LCR8SM78

(20) Disassemble nut ring (5) by using the jig.



125LCR8SM79

Drive shaft sub assy disassembly

(21) Separate drive shaft sub assembly from casing (8).



125LCR8SM80

(22) Disassemble taper bearing (3) and oil seal (27) by using a press machine.



125LCR8SM81

(23) Disassemble sleeve (25) and O-ring (26).



125LCR8SM82

(24) Disassemble the outer ring of taper bearing (3) in casing (8) by using the jig.



125LCR8SM83

3) ASSEMBLY

※ Even though assembly is accomplished by reversing disassembly steps, be careful of the following.

- ① Repair the damaged part when disassembling and prepare parts for exchange in advance.
- ② All parts should be cleaned with cleaner, dried with compressed air.
- ③ Sliding surface, O-ring, bearing and oil seal should be lubricated with clean hydraulic oil, prior to final assembly.
- ④ Replacement of O-ring and oil seal with new parts is generally recommended.
- ⑤ Use a torque wrench to make sure that assembly fasteners are tightened to specified values.
- ⑥ When assembling bolt, spread loctite.

Carrier No.1 sub assembly

- (1) After heating the carrier No.1 (17), assemble carrier pin No.1 (21) to the side without the hole.



125LCR8SM84

- (2) After drilling $\varnothing 6$ hole, assemble spring pin (15).(3 pcs)



125LCR8SM85

(3) Caulking is performed on the assembled spring pin unit.

※ To cover pins, implement the caulking in two places that are located direction of 180 degrees around assembled spring pin.

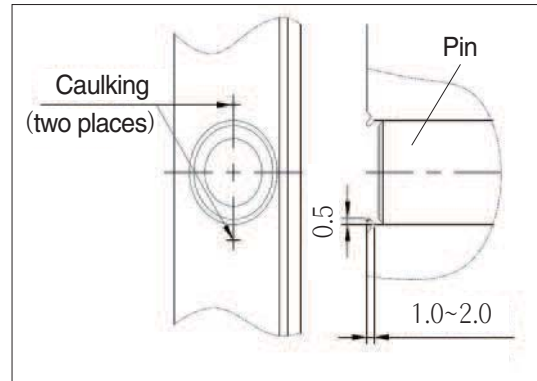

125LCR8SM86

(4) Assemble thrust washer No.1 (lower) (20).
(3 pcs)



125LCR8SM87

(5) Assemble needle bearing No.1 (19).(3 pcs)



125LCR8SM88

(6) Assemble thrust plate (24).



125LCR8SM89

- (7) Assemble planetary gear No.1 (18) of which groove is faced downward.(3 pcs)



125LCR8SM90

- (8) Assemble thrust washer No.1 (upper) (32).
(3 pcs)



125LCR8SM91

- (9) Assemble snap ring (23) (3 pcs), complete carrier No.1 sub assembly.
※ Gear rotation state should be smooth.



125LCR8SM92

Carrier No.2 sub assy assembly

- (10) Assemble needle bearing No.2 (12) in the planetary gear No.2 (11).



125LCR8SM93

- (11) After spreading grease on thrust washer No.2 (13), assemble it on both upper side and lower side of planetary gear No.2.



125LCR8SM94

- (12) Assemble thrust plate (24).



125LCR8SM95

- (13) Assemble planetary gear No.2 in the carrier No.2 (10).(3 pcs)
※ Thrust washer No.2 should not separated.



125LCR8SM96

- (14) Assemble carrier pin No.2 (14) to match the pin hole of the carrier No.2.(3 pcs)



125LCR8SM97

(15) Assemble spring pin (15).(3 pcs)



125LCR8SM98

(16) Caulking is performed on the assembled spring pin unit.

- ※ To cover pins, implement the caulking in two places that are located direction of 180 degrees around assembled spring pin.

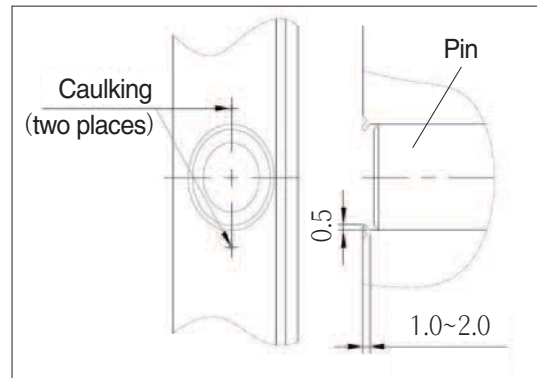

125LCR8SM99

Drive shaft sub assy assembly

(17) After heating sleeve (25), assemble O-ring (26) to groove of inside diameter in it.



125LCR8SM100

(18) Shrink fit the sleeve on drive shaft (2).

- ※ Be careful of fully seat at the bottom.



125LCR8SM101

- (19) Shrink fit taper bearing (3) on drive shaft, complete drive shaft sub assembly.



125LCR8SM102

Casing assembly

- (20) Press outer ring of the taper bearing in the casing (8) by using the jig.



125LCR8SM103

- (21) Press in oil seal (27) by using the jig.
※ Be careful of the direction of the assembly.



125LCR8SM104

- (22) Assemble drive shaft sub assembly.
※ Be careful of damage of oil seal.



125LCR8SM105

(23) After fixing drive shaft so that it does not fall, and then turn it over, press taper bearing (4).



125LCR8SM106

(24) Assemble nut ring (5) by using the jig.
※ Tightening torque : 3.5 ± 0.4 kgf · m
(25.3 ± 2.9 lbf · ft)



125LCR8SM107

(25) Place lock plate (6) on the nut ring.



125LCR8SM108

(26) After spreading loctite #242, assemble the bolt (7) (4 pcs).

※ Tightening torque : 2.5 ± 0.25 kgf · m
(18.1 ± 1.8 lbf · ft)



125LCR8SM109

(27) Press parallel pin (31) by using press machine.



125LCR8SM110

(28) Spread the loctite #515 on the casing with reference to the right detail view.
※ Loctite should not flow into casing.

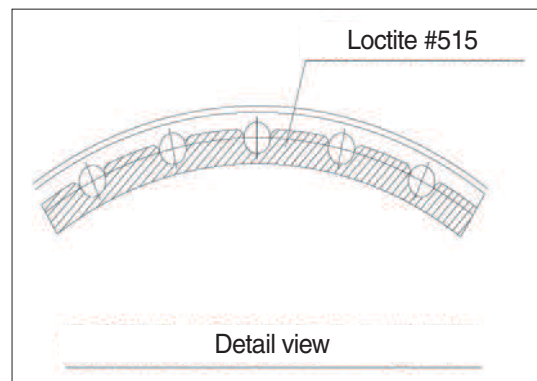

125LCR8SM111

(29) Assemble ring gear (1) in accordance with a pin hole on casing.
※ Be careful of damage of the ring gear.



125LCR8SM112

(30) Assemble carrier No.2 sub assembly.



125LCR8SM113

(31) Assemble sun gear No.2 (16).



125LCR8SM114

(32) Assemble carrier No.1 sub assembly.



125LCR8SM115

(33) Assemble sun gear No.1 (22) of which grinding surface is faced downward.



125LCR8SM116

(34) Fill with gear oil 3.5 liter.



125LCR8SM117

GROUP 5 SWING DEVICE (TYPE 2)

1. REMOVAL AND INSTALL OF MOTOR

1) REMOVAL

- (1) Lower the work equipment to the ground and stop the engine.
 - (2) Operate the control levers and pedals several times to release the remaining pressure in the hydraulic piping.
 - (3) Loosen the breather slowly to release the pressure inside the hydraulic tank.
- ▲ Escaping fluid under pressure can penetrate the skin causing serious injury.
- ※ When pipes and hoses are disconnected, the oil inside the piping will flow out, so catch it in oil pan.

- (4) Disconnect hose assembly (2).
- (5) Disconnect pilot line hoses (3, 4, 5, 6, 7, 9).
- (6) Sling the swing motor assembly (1) and remove the swing motor mounting socket bolts (10).
 - Motor device weight : 32kg (71lb)
- (7) Remove the swing motor assembly.
 - ※ When removing the swing motor assembly, check that all the piping have been disconnected.

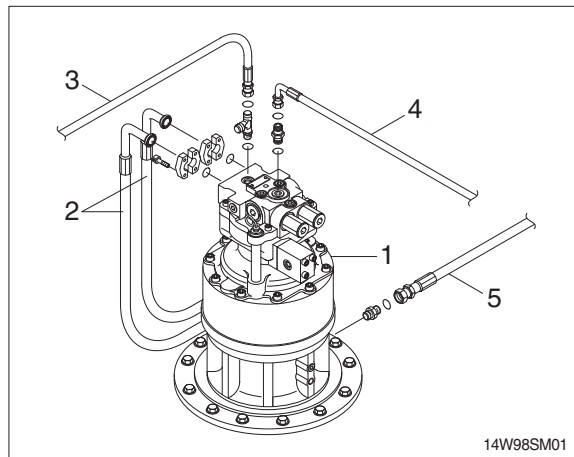

2) INSTALL

- (1) Carry out installation in the reverse order to removal.
- (2) Bleed the air from the swing motor.
 - ① Remove the air vent plug.
 - ② Pour in hydraulic oil until it overflows from the port.
 - ③ Tighten plug lightly.
 - ④ Start the engine, run at low idling and check oil come out from plug.
 - ⑤ Tighten plug fully.
- (3) Confirm the hydraulic oil level and check the hydraulic oil leak or not.

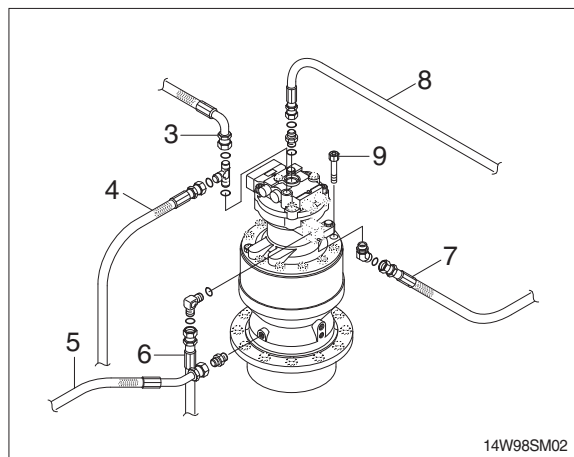

2. DISASSEMBLY AND ASSEMBLY OF SWING MOTOR

1) STRUCTURE

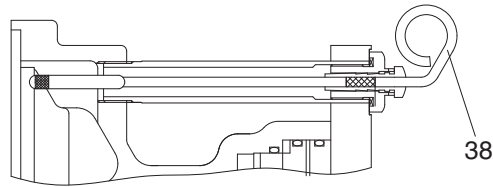

DETAIL K

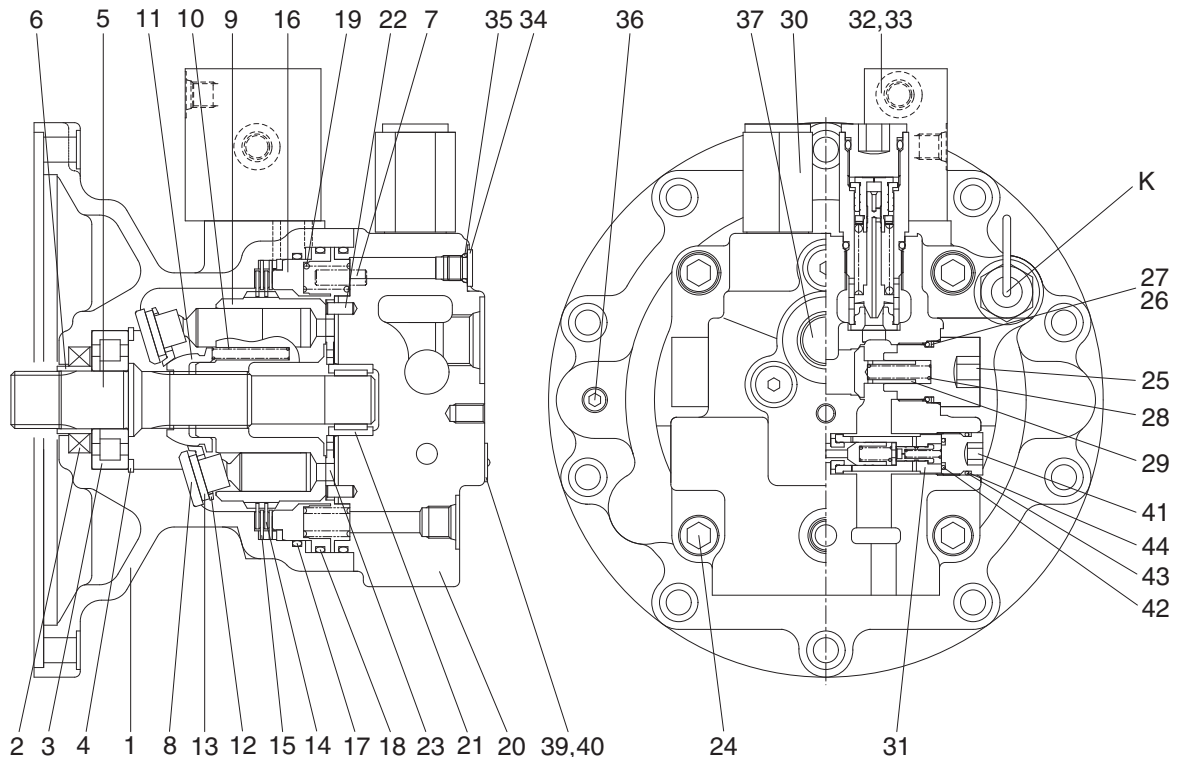

14W92SM02

1	Body	16	Brake piston	31	Anti-rotating valve
2	Oil seal	17	O-ring	32	Time delay valve
3	Roller bearing	18	O-ring	33	Wrench bolt
4	Snap ring	19	Brake spring	34	Plug
5	Drive shaft	20	Rear cover	35	O-ring
6	Bushing	21	Needle bearing	36	Plug
7	Pin	22	Pin	37	Plug
8	Shoe plate	23	Valve plate	38	Level gauge
9	Cylinder block	24	Wrench bolt	40	Rivet
10	Spring	25	Plug	41	Plug
11	Ball guide	26	Back up ring	42	O-ring
12	Set plate	27	O-ring	43	O-ring
13	Piston assembly	28	Spring	44	Back up ring
14	Friction plate	29	Check		
15	Separate plate	30	Relief valve		

2) DISASSEMBLY

- (1) Lift the motor out. Clean the motor in kerosene and dry with compressed air.
 - ※ To avoid dust inside the motor, mask all the ports of the motor with tapes.

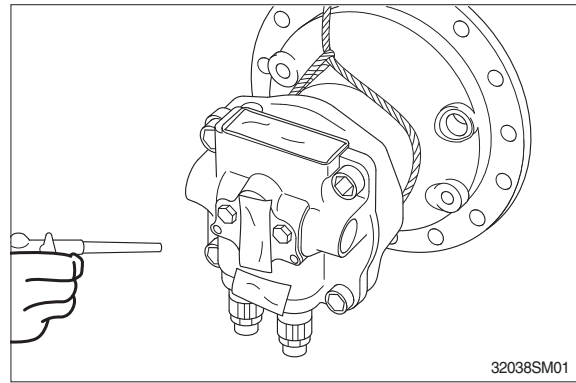

- (2) Loosen the drain plug to discharge oil in the body(1).

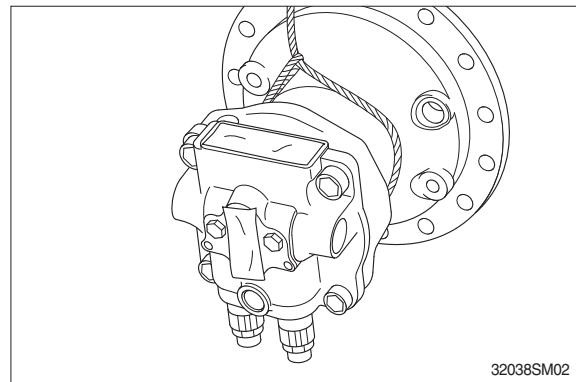

- (3) Fix the drive shaft (5) on the workbench with the end of output shaft down. Put matching marks on body (1) and valve rear cover (20) for easy reassembly.

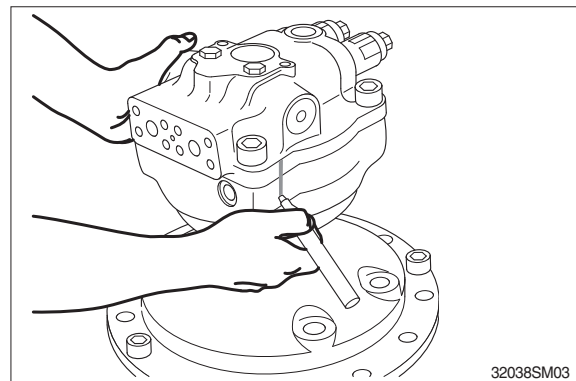

- (4) Remove the valve (32).

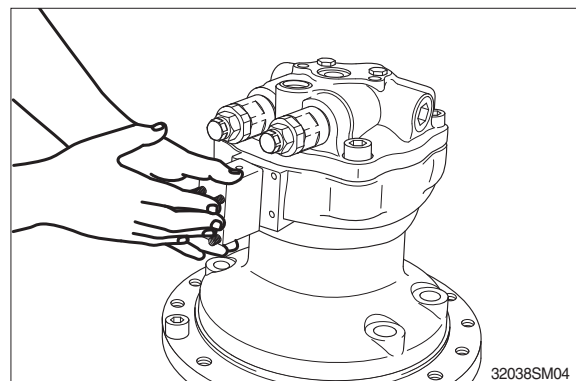

- (5) Remove the relief valve (30) from rear cover (20).

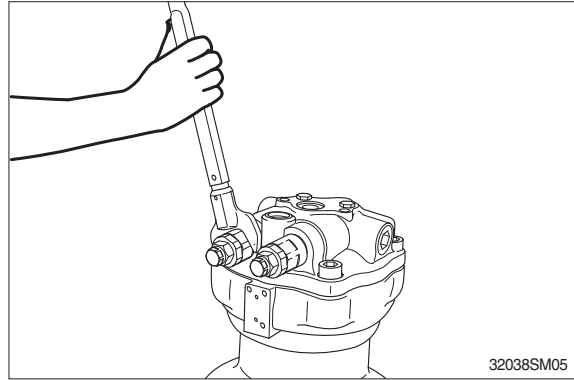

- (6) Remove plug (25) from rear cover (20) and spring (28), check (29).
※ Be careful not to damage the check seat assembly.

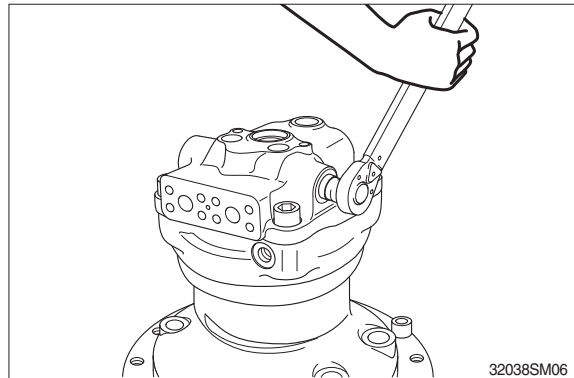

- (7) Remove rear cover (20) from body (1).
Then, remove the valve plate (23) from rear cover (20) with care.

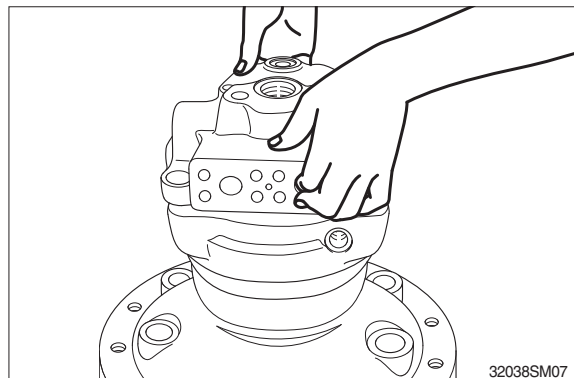

- (8) Remove the brake spring (19) from brake piston (16).

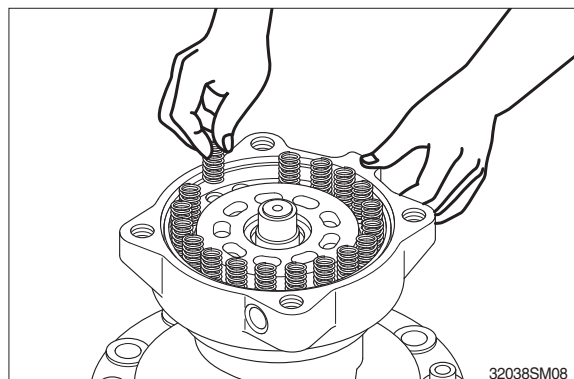

(9) Remove brake piston (16) from body (1).

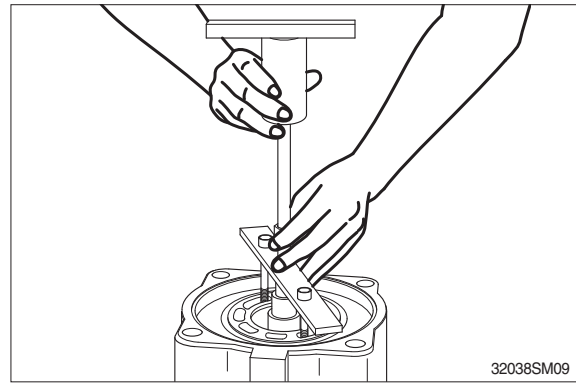

(10) Remove the cylinder (9) from the drive shaft (5) with the motor positioned horizontally. Remove ball guide (11), set plate (12), piston (13) and shoe plate (8).

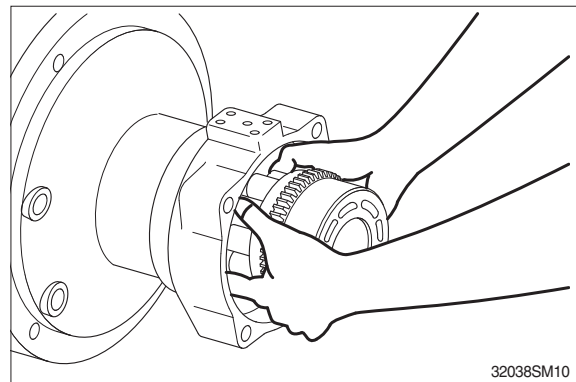

(11) Remove friction plate (14) and separate plate (15) from body (1).

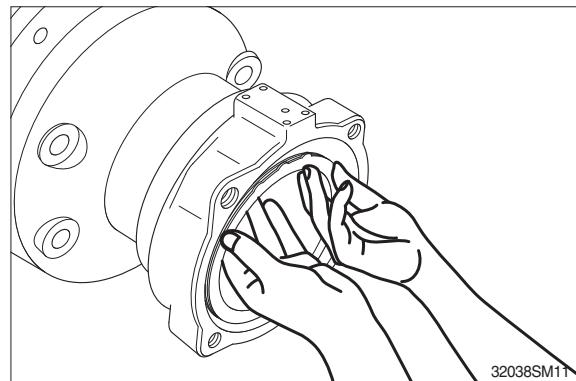

(12) Remove snap ring (4) and remove drive shaft (5) from body (1).

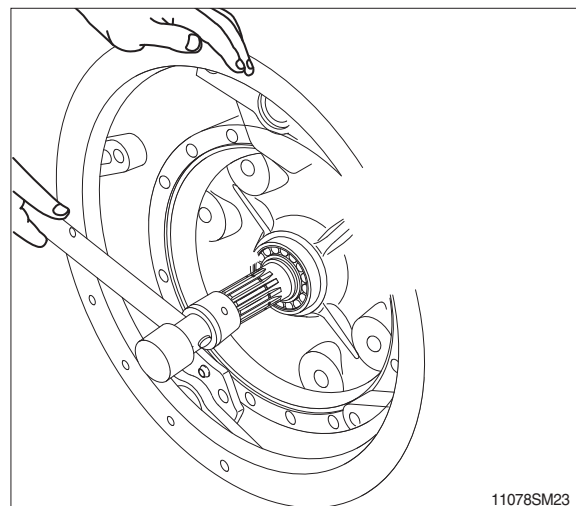

(13) Remove the cone of roller bearing (3) by press.

※ Do not reuse bearings.

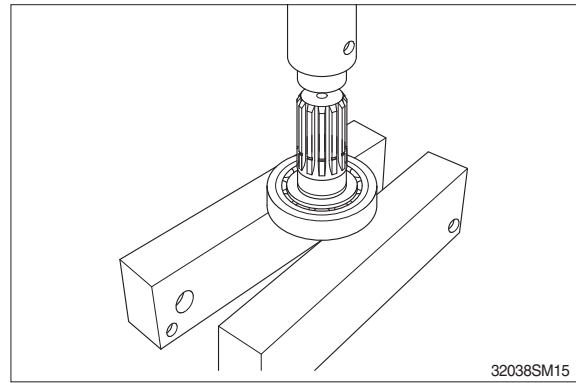
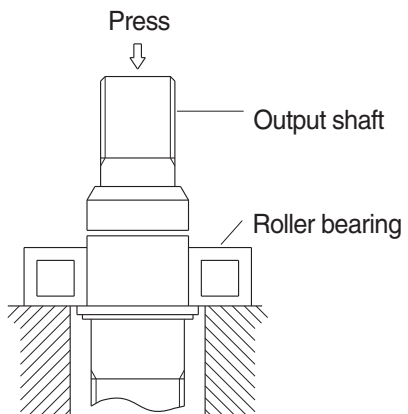

(14) Remove bushing (6) and oil seal (2) from body (1).

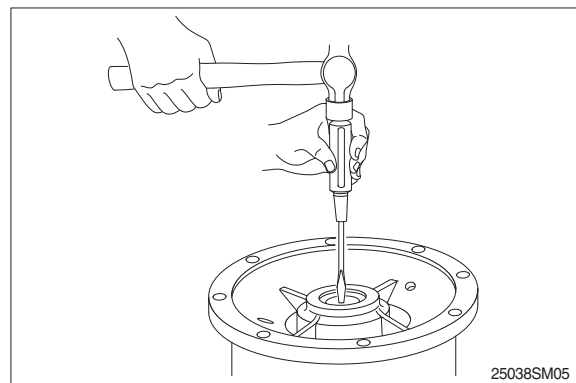

(15) Remove the needle bearing (21) from the rear cover (20) by using slide hammer bearing puller.

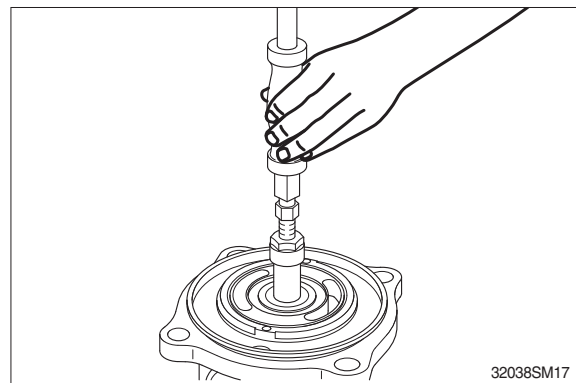

(16) When disassembling the relief valve, release the adjusting screw (5).
Remove the piston (6), spring seat (8), spring (4) and plunger (3) with the body (1) downwards.

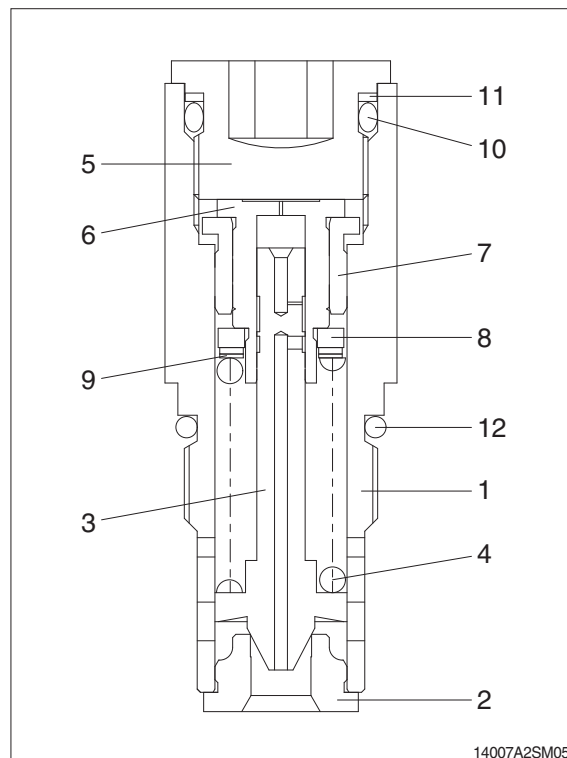

This completes disassembly.

3) ASSEMBLY

Do the reassembly in the reverse procedure of the disassembly.

- (1) Apply three bond of white color on outer surface of oil seal (2) and insert it to the body (1).

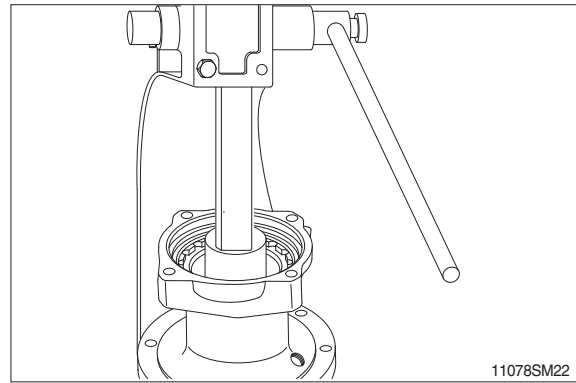

- (2) Install the roller bearing (3) to the drive shaft (5).

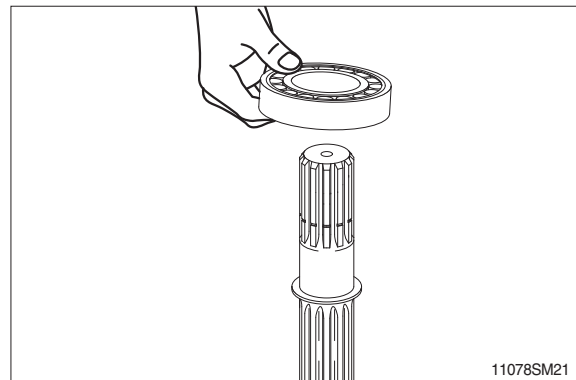

- (3) Insert the drive shaft (5) into the body (1) with the plastic hammer lightly.

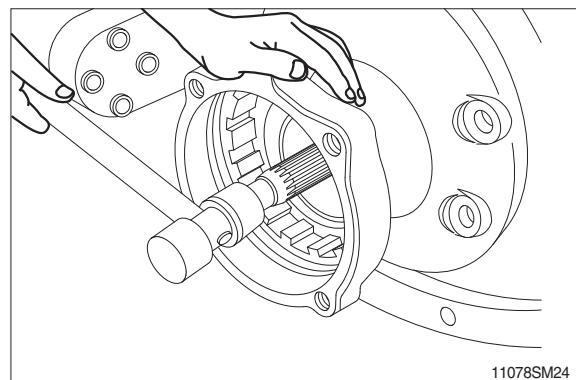

- (4) Install the snap ring (4) to the body (1).

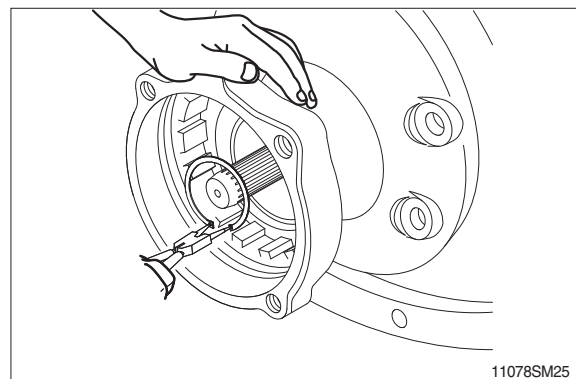

- (5) Insert the shoe plate (8) with the body (1) position horizontally.

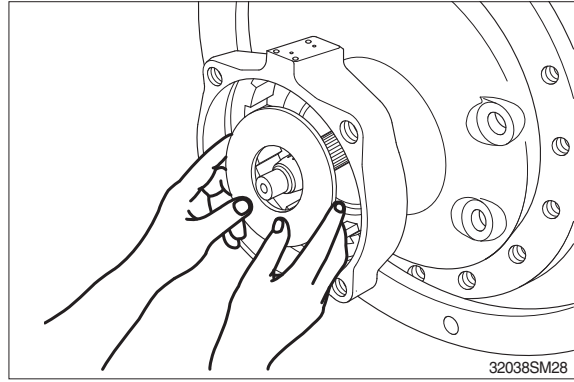

- (6) Insert the ball guide (11) into the cylinder (9).

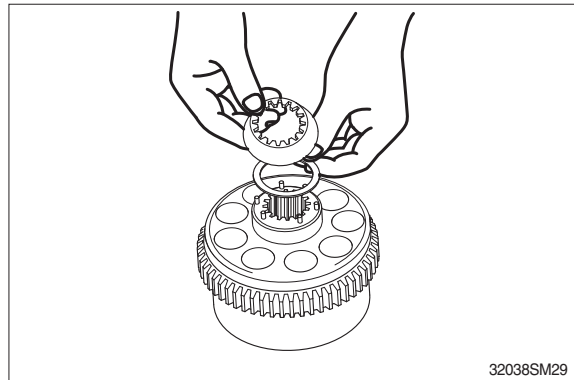

- (7) Install the piston sub-assembly (13) to the set plate (12).

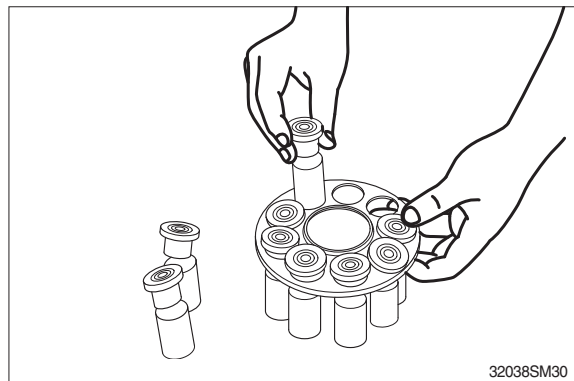

- (8) Reassemble the piston assembly (9) to the body (1).

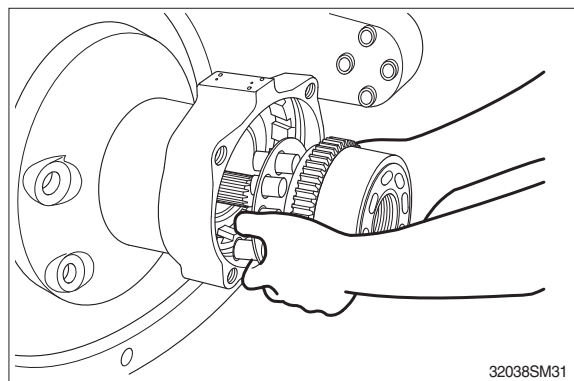

(9) Assemble friction plate (14) and separate plate (15) to the body (1).

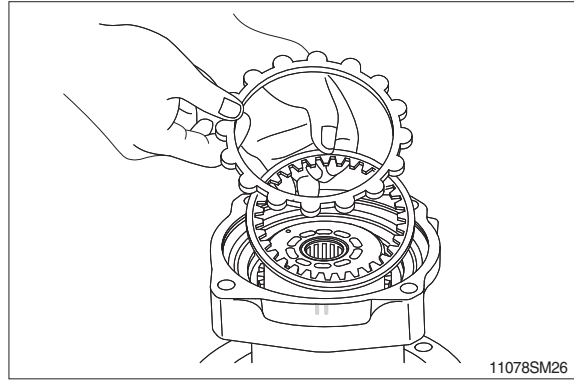

(10) Insert O-ring (17) inside the body (1).

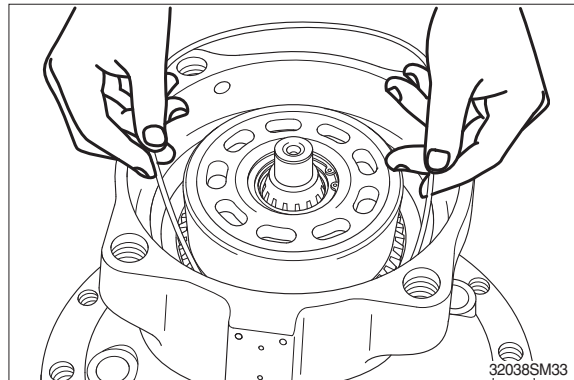

(11) Reassemble brake piston (16) to the body (1).

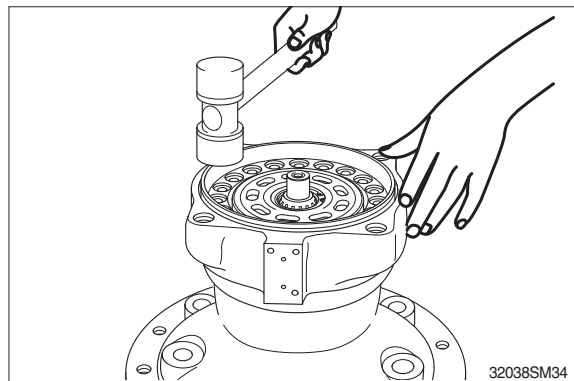

(12) Reassemble brake spring (19) to the brake piston (16).

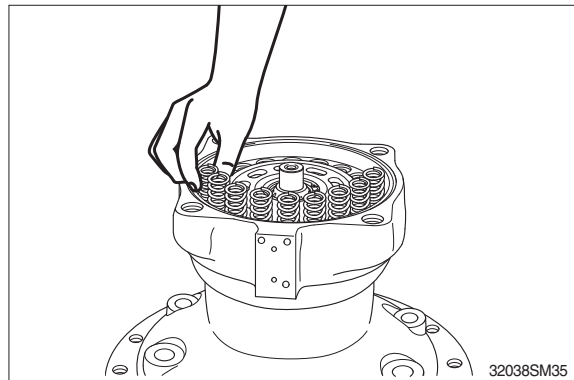

(13) When assembling the needle bearing (21), insert the needle bearing (21) into rear cover (20) by hammering.

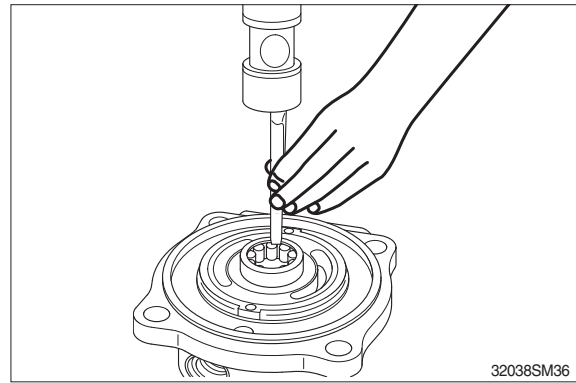

(14) Reassemble valve plate (23) to the rear cover (20) and reassemble O-ring (18).

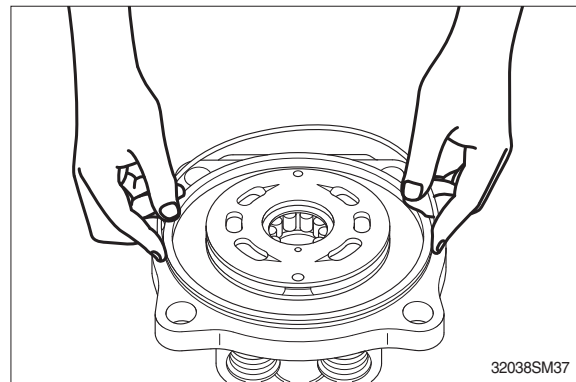

(15) Connect the rear cover (20) with the body (1) and tighten the wrench bolt (24).

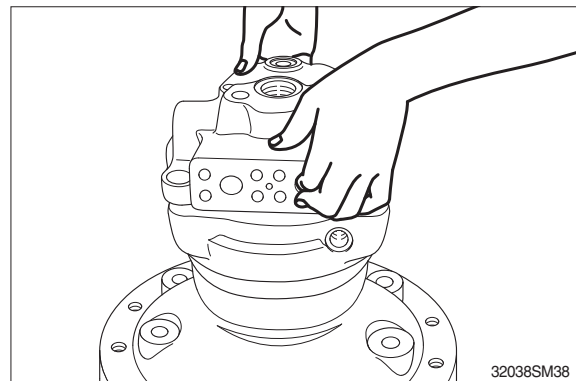

(16) Insert check (29) and spring (28) in the valve casing and install O-ring (27) and back up ring (26). Tighten plug (25) to the rear cover (20).

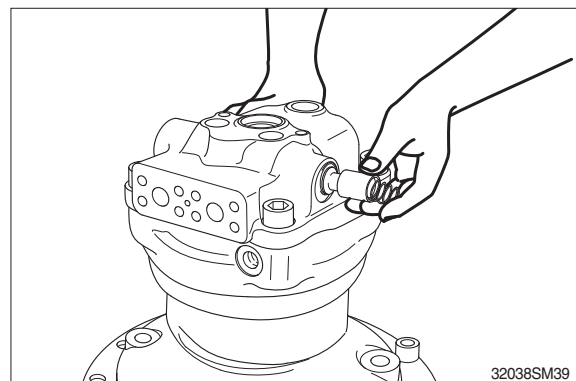

(17) Insert O-rings to the relief valve (30) and reassemble them to rear cover (20).

This completes assembly.

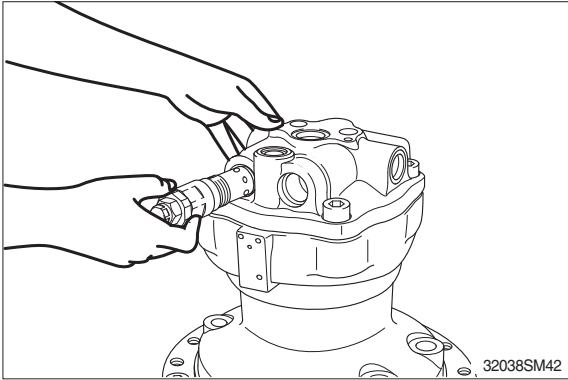

3. REMOVAL AND INSTALL OF REDUCTION GEAR

1) REMOVAL

- (1) Remove the swing motor assembly.
For details, see removal of swing motor assembly.
- (2) Sling reduction gear assembly (1) and remove mounting bolts (2).
- (3) Remove the reduction gear assembly.
 - Reduction gear device weight : 60 kg
(132 lb)



2) INSTALL

- (1) Carry out installation in the reverse order to removal.
 - Tightening torque : 29.6 ± 3.2 kgf · m
(214 ± 23.1 lbf · ft)

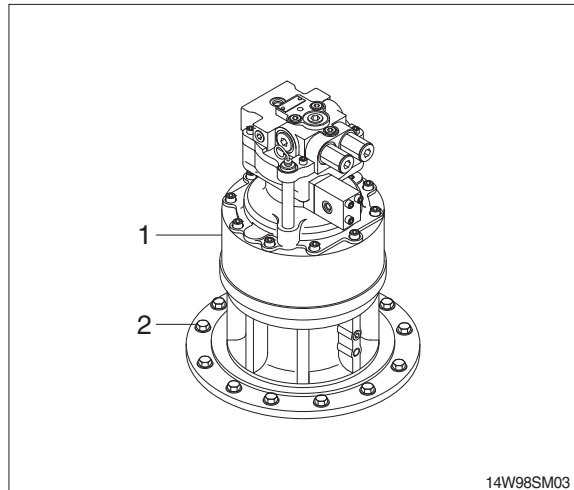

4. DISASSEMBLY AND ASSEMBLY OF REDUCTION GEAR

1) STRUCTURE

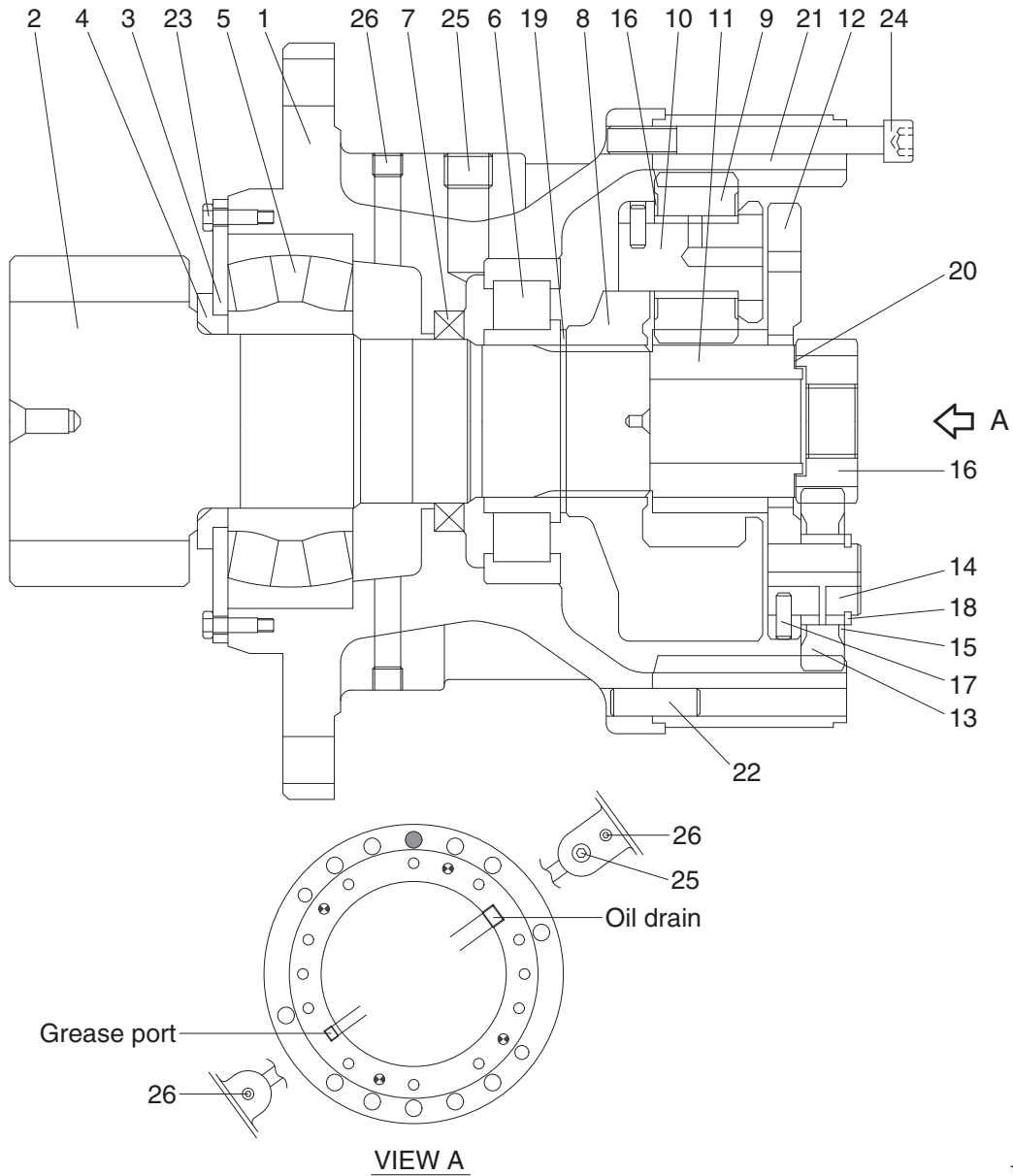

1	Casing	10	Pin No.2 assembly	19	Stop ring
2	Drive shaft	11	Sun gear No. 2	20	Side plate No. 1
3	Cover plate	12	Carrier No. 1	21	Ring gear
4	Spacer	13	Planet gear No. 1	22	Knock pin
5	Roller bearing	14	Pin No.1	23	Hexagonal bolt
6	Roller bearing	15	Thrust washer (B)	24	Socket head bolt
7	Oil seal	16	Sun gear No. 1	25	Plug
8	Carrier No. 2	17	Spring pin	26	Plug
9	Planet gear No. 2	18	Stop ring		

14W92SM03

2) DISASSEMBLY

- (1) Remove level gauge (38) from the swing motor casing.
※ Pour the gear oil out of reduction gear into the clean bowl to check out the friction decrease.

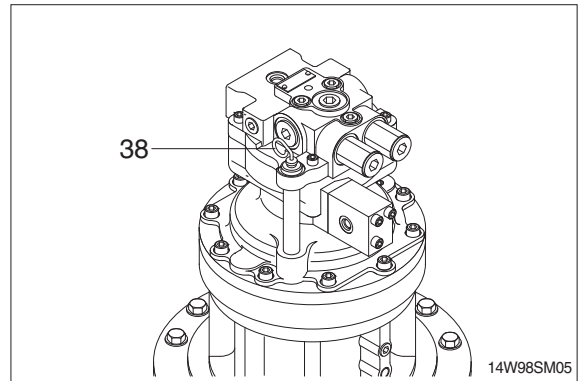

- (2) Loosen the socket bolts (24) to separate swing motor from reduction gear.

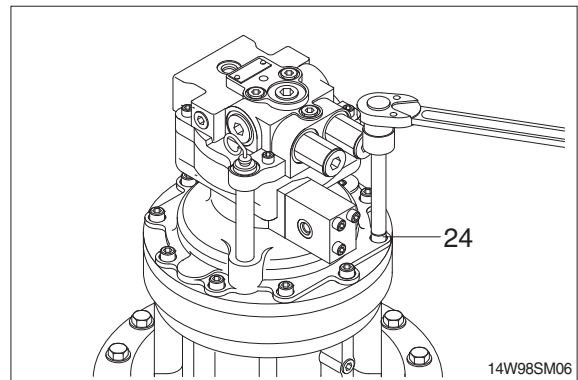

- (3) Remove sun gear 1 (16).

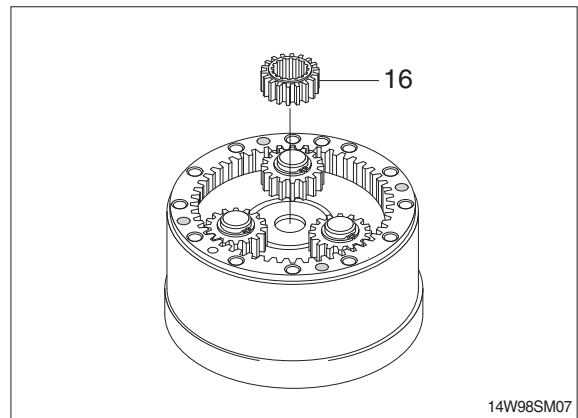

- (4) Tighten two M10 eye bolts to carrier 1 (12) and lift up and remove carrier 1 (12) as subassembly.

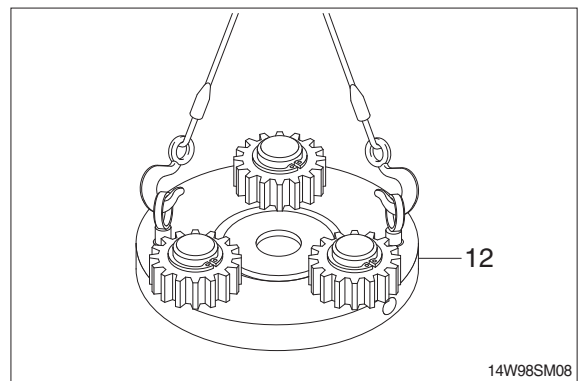

(5) Disassembling carrier 1 (12) assembly.

- ① Remove stop ring (18).
- ② Remove thrust washer (15) and planet gear 1(13) from the carrier 1 (12).
- ③ Using M8 solid drill, crush spring pin (17) so that the pin 1 (14) can be removed by hammering.

- ※ Do not reuse spring pin (17).
- ※ Do not remove pin 1 (14), carrier 1 (12) and spring pin (17) but in case of replacement.
- ※ Put matching marks on the planet gear 1 (13) and the pin 1 (14) for easy reassembly.

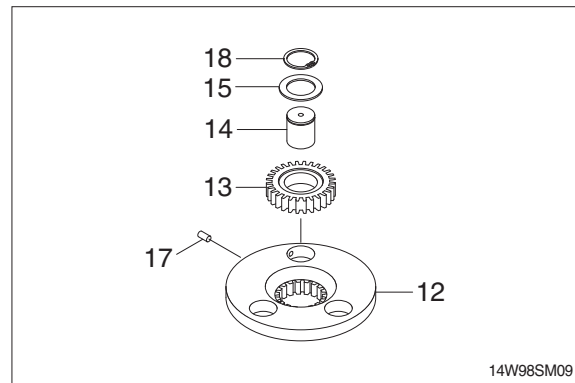

(6) Remove sun gear 2 (11) and side plate 1 (20) from carrier 2 (8).

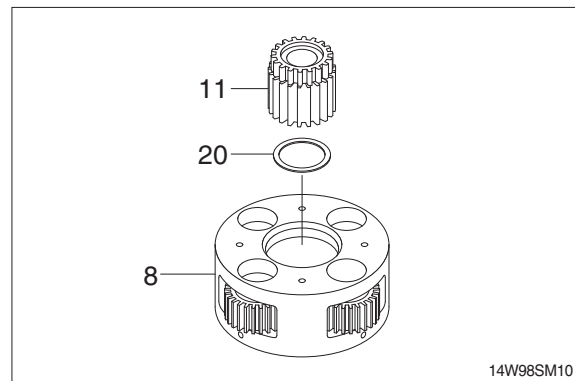

(7) Remove carrier 2 (8) assembly from casing (1).

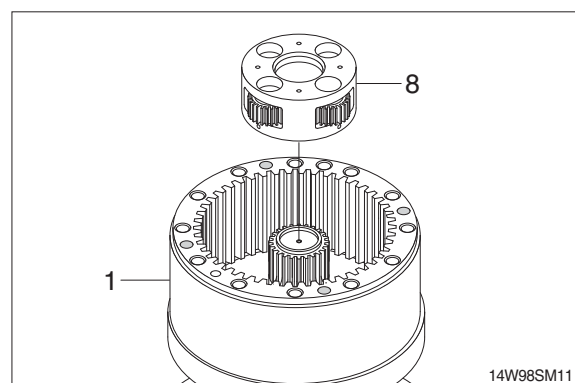

(8) Disassembling carrier 2 (8) assembly.

- ① Using M8 solid drill, crush spring pin (17) so that the pin 2 (10) can be removed.
- ※ Do not reuse spring pin (17).
- ② Remove pin 2 (10) and planet gear 2 (9) from the carrier 2 (8).
- ※ Put matching marks on the planet gear 2 (9) and the pin 2 (17) for easy reassembly.
- ※ Do not disassemble pin 2 (10), carrier 2 (8) and spring pin (17) but in case of replacement.

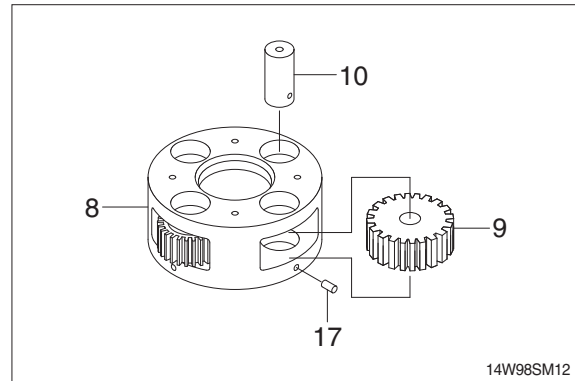

(9) Tighten two M16 eyebolt to the ring gear (21) and then lift the ring gear (21) out of casing (1).

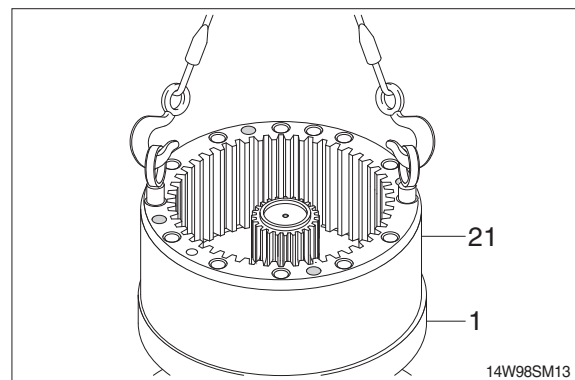

(10) Remove stop ring (19) from the drive shaft (2).

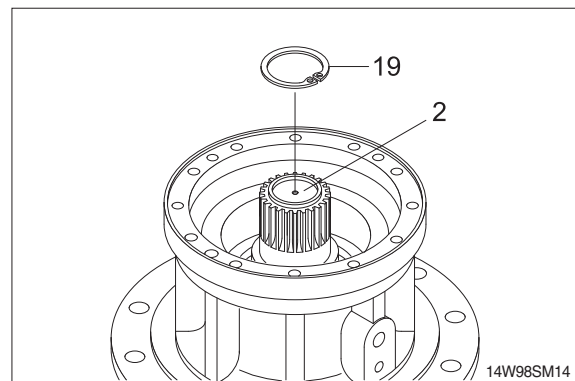

(11) Remove drive shaft (2) with roller bearing (6) and oil seal (7) assembled. Remove knock pin (22) from the casing (1).

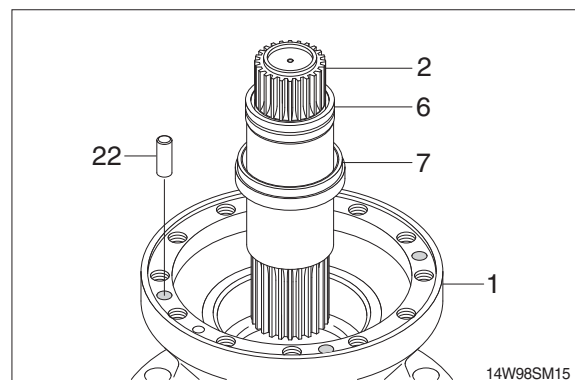

- (12) Remove roller bearing (6) and oil seal (7) from the drive shaft (2).
※ Do not reuse oil seal (20) once removed.

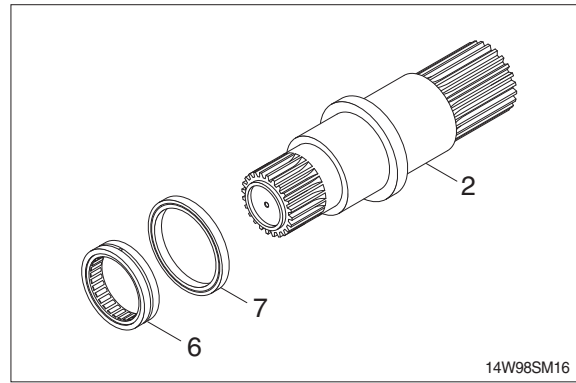

- (13) Using the bearing disassembly tool, remove roller bearing (5).

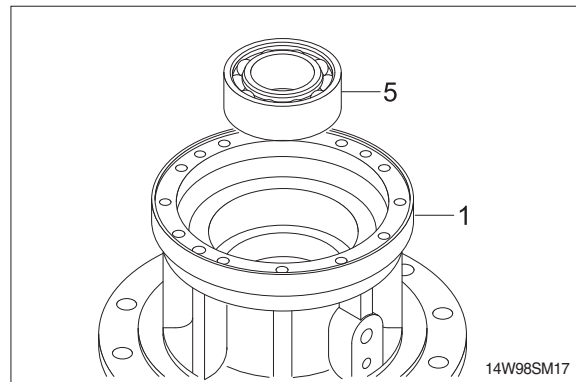

- (14) Remove plugs (25, 26) from the casing (1).

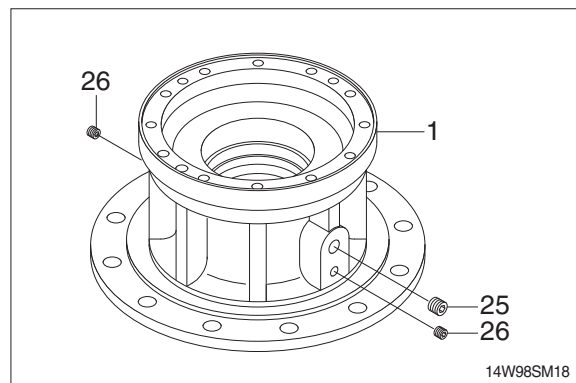

3) ASSEMBLY

- (1) Assemble roller bearing (5) inside the casing (1).

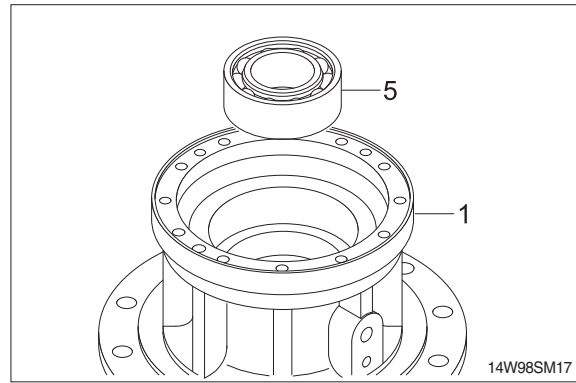

- (2) Assemble the drive shaft (2) into the casing (1) and then install oil seal (7) and roller bearing (6).

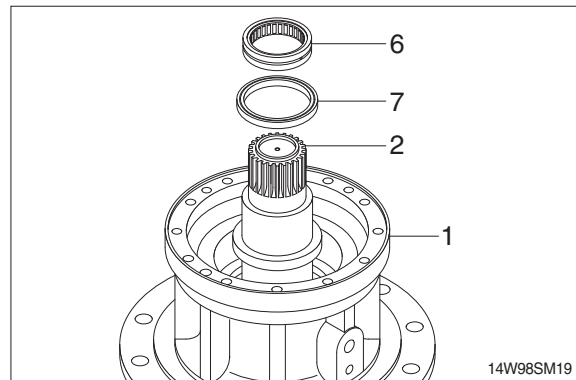

- (3) Install stop ring (19) on top of drive shaft (2).

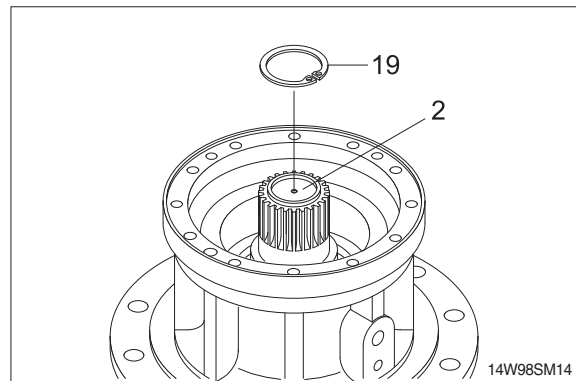

- (4) Apply loctite to the tapped holes of casing (1).

- (5) Tighten 2 M16 eye bolts to the ring gear (21) and lift up and then assemble it onto the casing (1).

※ Don't fail to coincide the knock pin (22) holes.

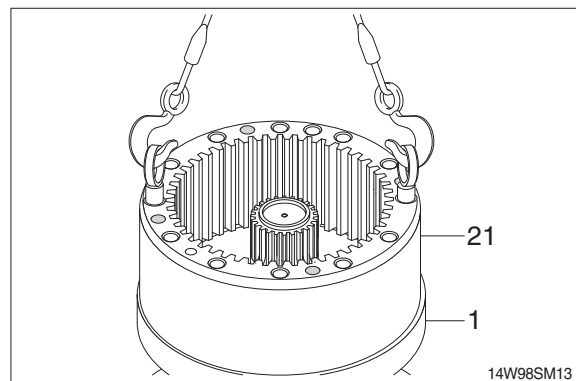

(6) Assembling carrier 2 (8) assembly.

- ① Install the planet gear 2 (9) inside the carrier 2 (8).
 - ② Assemble the pin 2 (10) to the carrier 2 (8) and then press the spring pin (17) by hammering.
 - ③ Punch 2 points of the spring pin (17) lip.
- ※ Take care not to mistake the matching marks of each part.

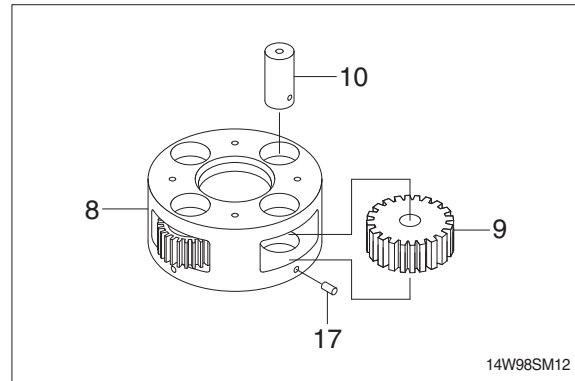

(7) Assemble carrier 2 (8) assembly correctly to the casing (1).

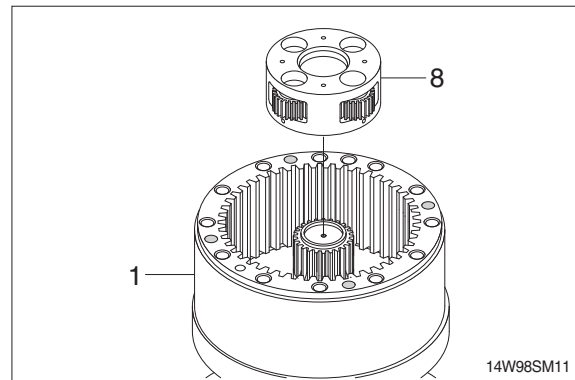

(8) Assemble sun gear 2 (11) and side plate 1 (20) to the center of the carrier 2 (8) assembly.

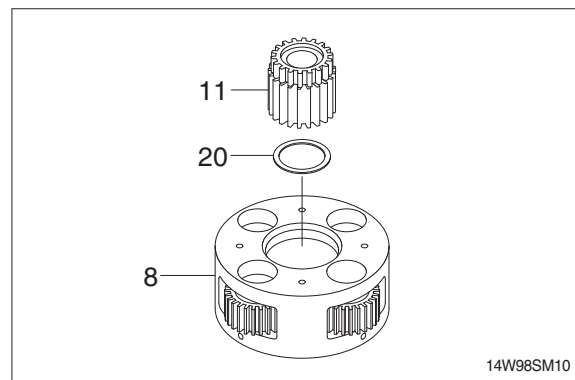

(9) Assembling carrier 1 (12) assembly.

- ① Assemble the pin1 (14) to the carrier 1 (12) and then press the spring pin (17) by hammering.
 - ② Punch 2 points of the spring pin's (17) lip.
 - ③ Assemble thrust washer (15), planet gear 1 (13), and then stop ring (18) to the pin 1 (14).
- ※ Take care not to mistake the matching marks of each part.

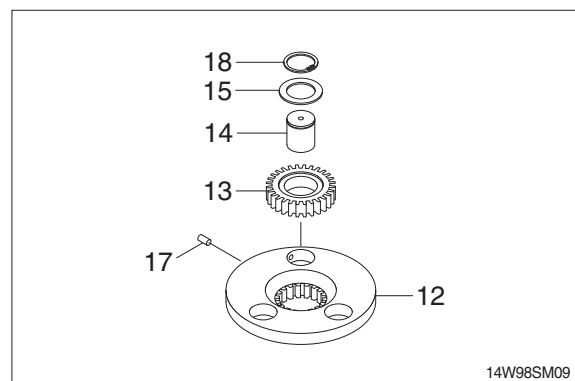

(10) Assemble carrier 1 (12) assembly into the ring gear (21).

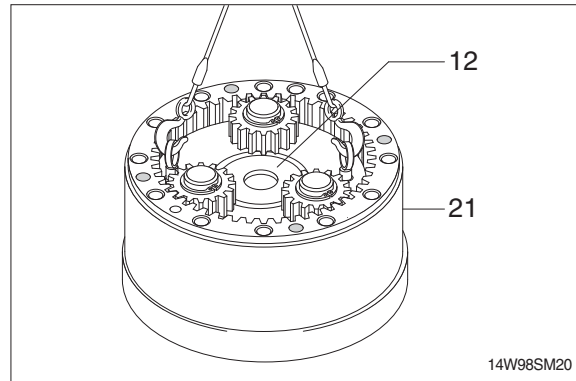

(11) Hammer 4 knock pins (22) around the ring gear (21).

(12) Assemble sun gear 1 (16) to the drive shaft of the swing reduction gear.

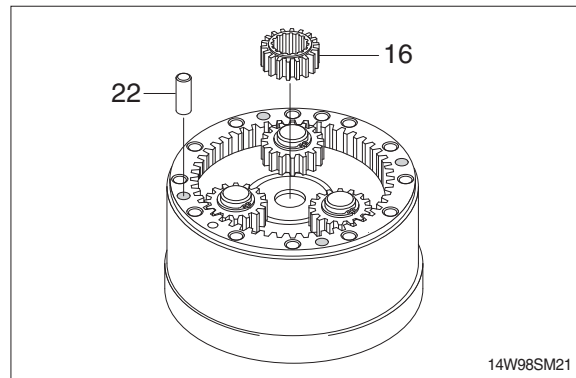

(13) Apply loctite to the tapped holes of the ring gear (21) and then mount swing motor onto the ring gear (21).

※ Don't fail to coincide the gauge bar hole.

(14) Tighten socket bolts (24) around the swing motor assembly.
· Tightening torque : 13.5 kgf · m (98 lbf · ft)

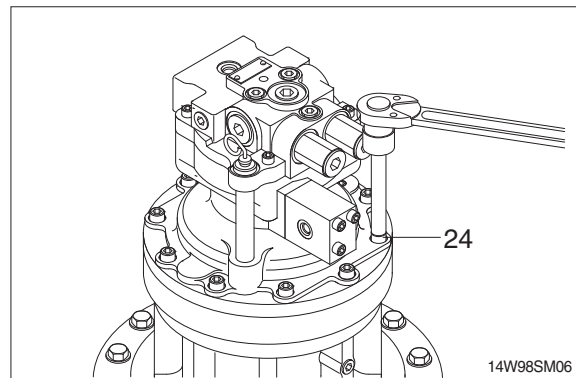

(15) Assemble plugs (25, 26) and level gauge (38).

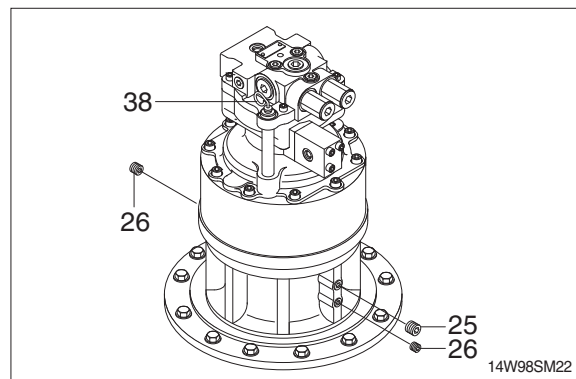

GROUP 6 TRAVEL DEVICE

■ TRAVEL MOTOR (TYPE 1)

1. REMOVAL AND INSTALL

1) REMOVAL

- (1) Swing the work equipment 90° and lower it completely to the ground.
- (2) Operate the control levers and pedals several times to release the remaining pressure in the hydraulic piping.
- (3) Loosen the breather slowly to release the pressure inside the hydraulic tank.

▲ Escaping fluid under pressure can penetrate the skin causing serious injury.

※ When pipes and hoses are disconnected, the oil inside the piping will flow out, so catch it in oil pan.

- (4) Remove the track shoe assembly.
For details, see **removal of track shoe assembly**.
- (5) Remove the cover.
- (6) Remove the hose.
※ Fit blind plugs to the disconnected hoses.
- (7) Remove the bolts and the sprocket.
- (8) Sling travel device assembly (1).
- (9) Remove the mounting bolts (2), then remove the travel device assembly.
· Weight : 240 kg (530 lb)

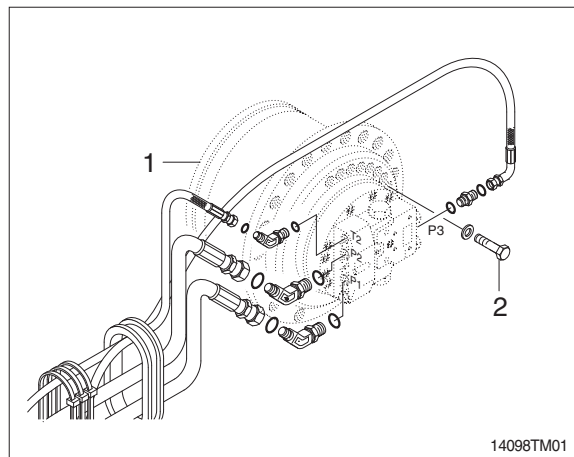

2) INSTALL

- (1) Carry out installation in the reverse order to removal.
- (2) Bleed the air from the travel motor.
 - ① Remove the air vent plug.
 - ② Pour in hydraulic oil until it overflows from the port.
 - ③ Tighten plug lightly.
 - ④ Start the engine, run at low idling, and check oil come out from plug.
 - ⑤ Tighten plug fully.
- (3) Confirm the hydraulic oil level and check the hydraulic oil leak or not.

2. TRAVEL MOTOR

1) STRUCTURE

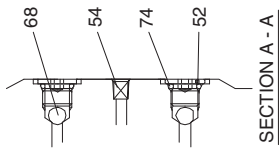
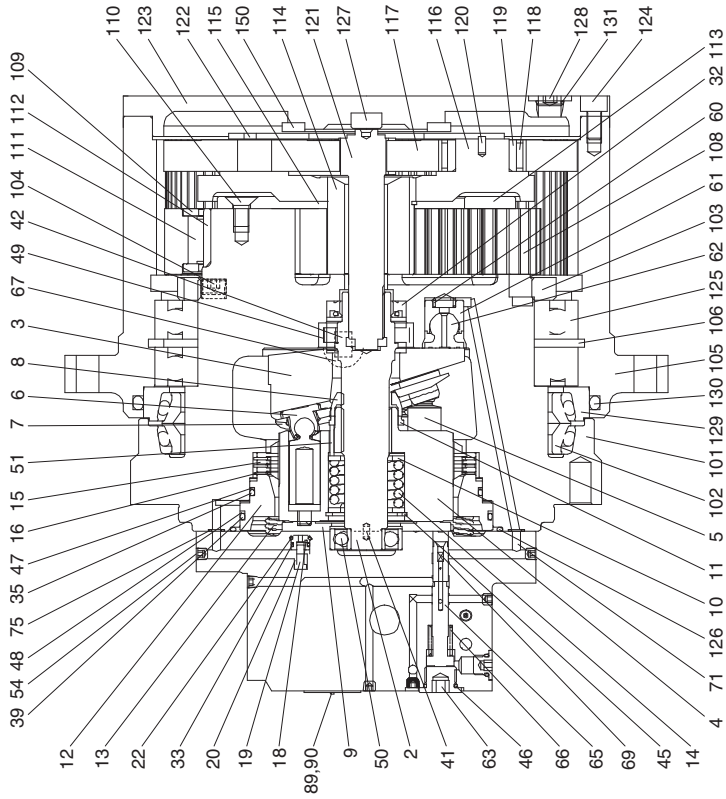
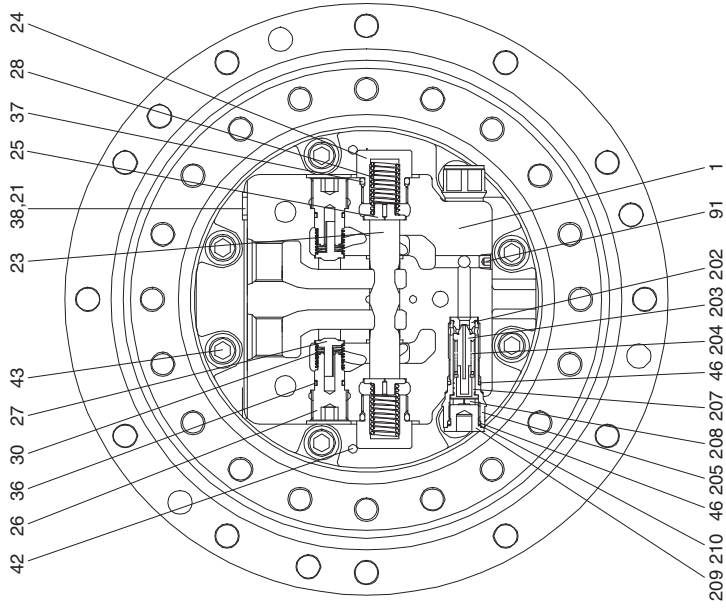

14062TW03

- | | | | | | | | | | | | | | | | |
|-----|----------------|-----|-----------------|-----|----------------|-----|----------------|-----|----------------|-----|-----------------|-----|-----|-----|-------|
| 1 | Rear flange | 19 | Valve | 39 | O-ring | 65 | 2 Speed spool | 108 | Planetary gear | 125 | Angular bearing | | | | |
| 2 | Shaft | 20 | Spring | 41 | Parallel pin | 66 | 2 Speed spring | 109 | Thrust washer | 126 | O-ring | | | | |
| 3 | Swash plate | 21 | Plug | 42 | Parallel pin | 67 | Pivot | 110 | Screw | 127 | Thrust washer | | | | |
| 4 | Cylinder block | 22 | Ring | 43 | Socket bolt | 68 | Steel ball | 111 | Needle bearing | 128 | Plug | | | | |
| 5 | Piston | 23 | Main spool | 45 | Snap ring | 69 | Set screw | 112 | Collar | 129 | Seal ring | | | | |
| 6 | Shoe | 24 | Main plug | 46 | O-ring | 71 | Orifice | 113 | Thrust plate | 130 | O-ring | | | | |
| 7 | Retainer plate | 25 | Retainer spring | 47 | Back up-ring | 74 | O-ring | 114 | Sun gear | 131 | O-ring | | | | |
| 8 | Thrust ball | 26 | Check plug | 48 | Back up-ring | 75 | O-ring | 115 | Snap ring | 150 | Thrust plate | | | | |
| 9 | Timing plate | 27 | Check valve | 49 | Roller bearing | 89 | Name plate | 116 | Holder | 205 | Body | | | | |
| 10 | Washer | 28 | Main spring | 50 | Ball bearing | 90 | Set screw | 117 | Planetary gear | 206 | Shim | | | | |
| 11 | Washer-collar | 30 | Check spring | 51 | Roller | 91 | Plug | 118 | Needle bearing | 207 | Piston | | | | |
| 12 | Piston-parking | 32 | Oil seal | 52 | Plug | 101 | Spindle | 119 | Inner race | 208 | Rod | | | | |
| 13 | Spring | 33 | O-ring | 54 | Plug | 102 | Floating seal | 120 | Spring pin | 209 | Plug | | | | |
| 14 | Spring | 35 | O-ring | 60 | Spring | 103 | Nut ring | 121 | Drive gear | 210 | Back up-ring | | | | |
| 15 | Friction plate | 36 | O-ring | 61 | Piston | 104 | Plug | 122 | Thrust plate | | | | | | |
| 16 | Mating plate | 37 | O-ring | 62 | Shoe | 105 | Hub | 123 | Cover | | | | | | |
| 18 | Seat valve | 38 | O-ring | 63 | Plug | 106 | Snap ring | 124 | Socket bolt | | | | | | |
| 2 | 210 | 46 | 204 | 203 | 202 | 91 | 1 | 209 | 210 | 46 | 204 | 203 | 202 | 91 | 1 |
| 42 | 26 | 36 | 30 | 27 | 43 | | | 42 | 26 | 36 | 30 | 27 | 43 | | |
| 23 | 38,21 | 25 | 37 | 28 | 24 | | | 23 | 38,21 | 25 | 37 | 28 | 24 | | |
| 39 | 54 | 48 | 75 | 35 | 47 | 16 | 15 | 51 | 7 | 6 | 8 | 3 | 67 | 49 | 42 |
| 104 | 110 | 112 | 109 | | | | | | | | | | | | |
| 110 | 123 | | | | | | | | | | | | | | |
| 122 | | | | | | | | | | | | | | | |
| 115 | 150 | | | | | | | | | | | | | | |
| 114 | | | | | | | | | | | | | | | |
| 121 | | | | | | | | | | | | | | | |
| 127 | | | | | | | | | | | | | | | |
| 117 | | | | | | | | | | | | | | | |
| 116 | | | | | | | | | | | | | | | |
| 120 | | | | | | | | | | | | | | | |
| 119 | | | | | | | | | | | | | | | |
| 118 | | | | | | | | | | | | | | | |
| 128 | | | | | | | | | | | | | | | |
| 131 | | | | | | | | | | | | | | | |
| 124 | | | | | | | | | | | | | | | |
| 60 | 61 | 62 | 63 | 14 | 45 | 69 | 65 | 66 | 46 | 63 | 41 | 2 | 50 | 9 | 89,90 |
| 106 | 105 | 104 | 103 | 102 | 101 | 91 | 90 | 89 | 75 | 74 | 71 | 69 | 68 | 67 | 66 |
| 124 | 123 | 122 | 121 | 120 | 119 | 118 | 117 | 116 | 120 | 116 | 117 | 127 | 121 | 114 | 115 |
| 32 | 60 | 61 | 62 | 63 | 14 | 45 | 69 | 65 | 66 | 46 | 63 | 41 | 2 | 50 | 9 |
| 108 | 109 | 110 | 111 | 112 | 113 | 114 | 115 | 116 | 117 | 118 | 119 | 120 | 121 | 122 | 123 |
| 125 | 126 | 127 | 128 | 129 | 130 | 131 | 128 | 131 | 124 | | | | | | |

2) TOOLS

(1) Standard tools

No.	Name	Description/Size	Qty
1	Hexagon wrench (JIS B 4650)	6 (M8) (PT1/4), 8 (M10)	each 1
		10 (M12) (PF1/2)	each 1
		4 (M6)	1
2	Socket wrench	-	1
3	Torque wrench	Nominal 30 kgf · m dial type	1
		Nominal 90 kgf · m dial type	1
4	Adapter for torque wrench	Socket 26, 27, 36	each 1
		Bar 4, 5, 6, 8, 10	each 1
5	Extension bar (JIS B 4637)	150 mm	1
6	Hammer (JIS B 4613)	12	1
7	Plastic hammer	L=300	1
8	(-) driver	150 mm	1
9	Snap ring plier	For shaft, For hole	1
10	Hanger	Weight : over 300 kgf	1
		Eye bolt (M16)	2
		Eye bolt (M10)	2
		Eye bolt (PF 1/2)	2
		Wire	1
11	Press	Press capacity above 200 kgf	1
12	Compressed air	3~5 kgf/cm ² , nozzle	1
13	Vessel	General vessel : W450 × D300 × H120	2
14	Heating vessel	Heating capacity : over 100°C	1
		Volume : 500 × 500 × 500	
15	Depth micro-meter	Measuring range : 0.04 ~ 0.3 mm	1
16	Air hammer	BRH-8 (compressed air 5~6 kgf/cm ²)	1
17	Sealant	Silicone rubber (780-RTV)	1

(2) Special tools

① Inversion working bench

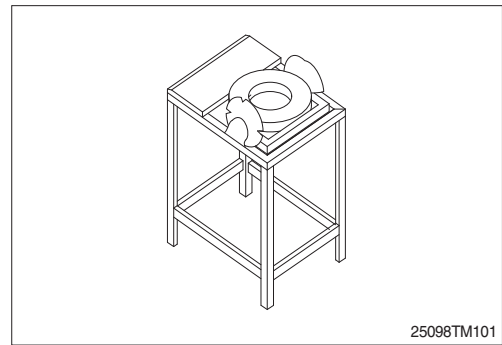

② Pressurize jig (I)

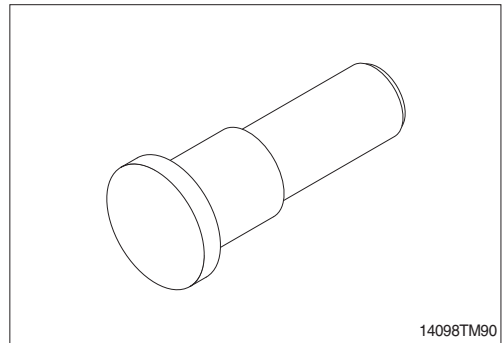

③ Pressurize jig (II)

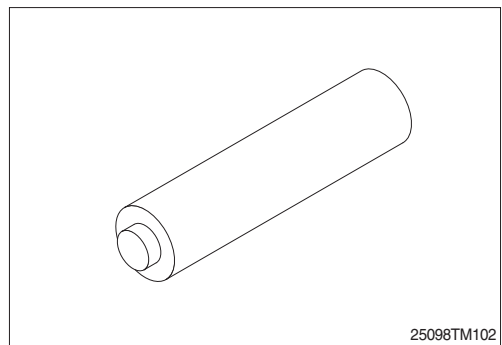

④ Aluminum bar

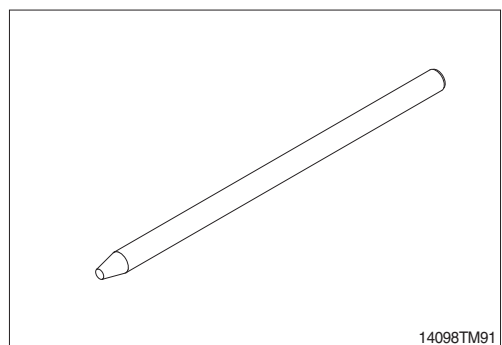

⑤ Steel bar

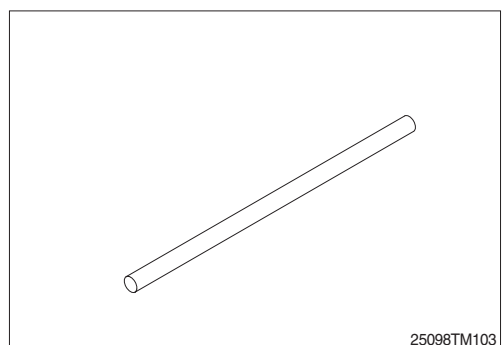

⑥ Sharp punch

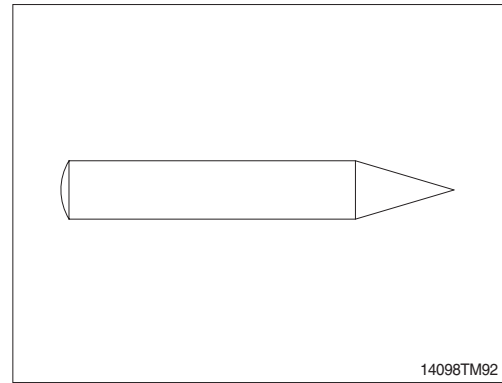

⑦ Draw bar

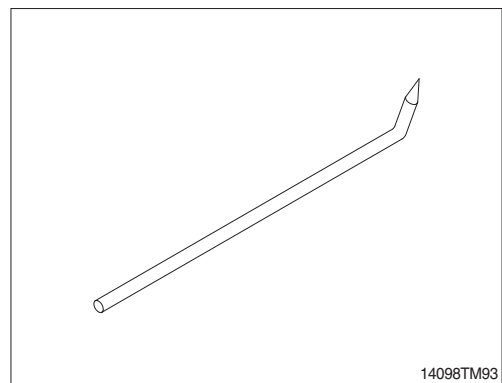

3) TIGHTENING TORQUE

Item No.	Parts name	Size	Qty	Tightening torque	
				kgf · m	lbf · ft
21	Plug	PF 3/8	1	10 ± 2	72.3 ± 14.5
24	Plug	M30×1.5	2	36 ± 7.2	260 ± 52.1
26	Plug	M24×1.5	2	17 ± 3.4	123 ± 24.6
43	Socket bolt	M10×1.5	8	5.9 ± 1.2	42.7 ± 8.7
52	RO plug	PF 1/4	4	3.0 ± 0.5	21.7 ± 3.6
54	Plug	NPTF 1/16	7	1.0 ± 0.25	7.2 ± 1.8
63, 209	Plug	PF 1/2	1	3.0 ± 0.5	21.7 ± 3.6
91	Plug	PT 1/8	4	1.25 ± 0.2	9 ± 1.4
104	Plug	PT 3/8	3	6.0 ± 0.9	43 ± 6.5
110	Screw	M6	4	0.83 ± 0.12	6 ± 0.9
128	Plug	PF 3/8	3	6.0 ± 0.9	43 ± 6.5
124	Socket bolt	M8	12	1.25 ± 0.2	9 ± 1.4
205	Body	M20	1	12 ± 1.5	86.8 ± 10.8
301	Plug	PF 1 1/2	1	26 ± 5.2	188 ± 37.6

3. DISASSEMBLY

3.1 GENERAL PRECAUTIONS

- 1) Spread rubber or vinyl cover on the work bench.
- 2) When disassembling the travel motor, provide a match mark on the mating face of each part.
- 3) Arrange the detached parts to prevent them from being damaged or lost.
- 4) The disassembled seals must be replaced with new ones as a rule even if they are free from damage. For disassembly, therefore, prepare new seals in advance.

3.2 DISASSEMBLY PROCEDURE

- 1) When inspecting or repairing the travel motors, use the disassembling procedures described below.
- 2) Numerals in brackets () following the part name denote the item numbers used in the structure drawing at page 8-68.
- 3) Prior to disassembly, install the travel motor on a inversion working bench.

3.3 DISASSEMBLING ORDER

1) DISASSEMBLING THE REDUCTION GEAR PART

- (1) Remove plugs (128, 3EA) and drain the reduction gear oil.
- (2) Loosen socket bolts (124, 16EA) and remove the cover (123).
 - ※ Remove the cover (123), after hook it, fit the eye bolt in a screw hole for use of the plug (128). If it's impossible, please remove the cover using the rod.
 - ※ You can have difficulty removing it because loctite is spread in the socket bolt (124).
 - ※ Tools
 - Hexagon wrench 6, 8

- (3) Remove thrust plate R (122) and drive gear (121).



(4) Remove planetary gear R (117), needle bearing, inner race (119) and holder (116) from hub (105).



(5) Remove sun gear (114), screw (110) and thrust plate F (113).



(6) Remove the thrust washer (109), planetary gears F (108), needle bearings (111) and collar (112) from hub (105).



(7) Remove the plugs (104, 3EA).



(8) Remove the nut ring (103) from hub (105).



(9) Remove the spindle (101) from the hub (105).

※ Remove it using a crane after eye bolt is assembled at the hub (105).

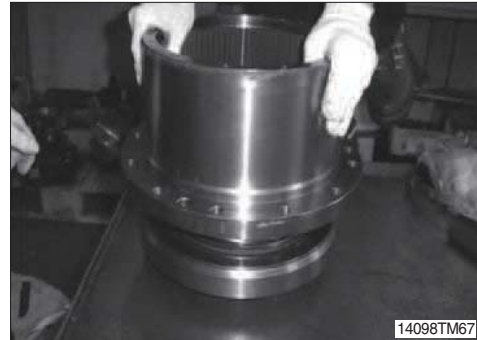

(10) Remove the floating seal (102), seal ring (129), angular bearings (125, 2EA), snap ring (106) and O-ring (130) from the hub (105).



(11) Remove the floating seal (102) from the spindle (101).

※ User can remove easily if using (-) drivers.



(12) Remove the oil seal (32) from spindle (101).

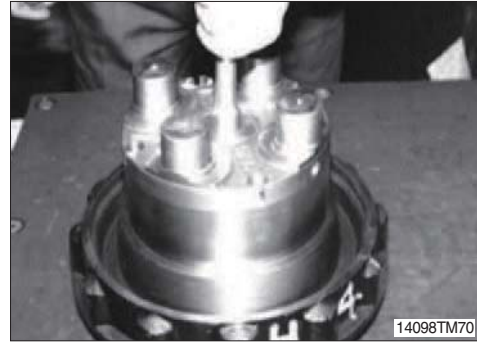

2) DISASSEMBLING THE HYDRAULIC MOTOR PART

(1) Remove the relief valve (70, 2EA) from rear flange (1).

※ Tools

- Hexagon socket
- Torque wrench



(2) Remove hexagon socket head bolts (43, 8EA) from the rear flange (1).

※ Tools

- Hexagon wrench 8

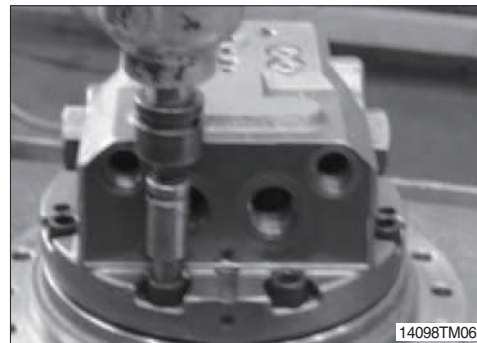

(3) Remove the rear flange (1) from the spindle (101).

(4) Remove the springs (13, 10EA) from the rear flange [1].

※ Remove the rear flange (1) carefully after taken using hands. Be careful not to detach the timing plate (9) and the spring (13) if twisted or beated by constraint.

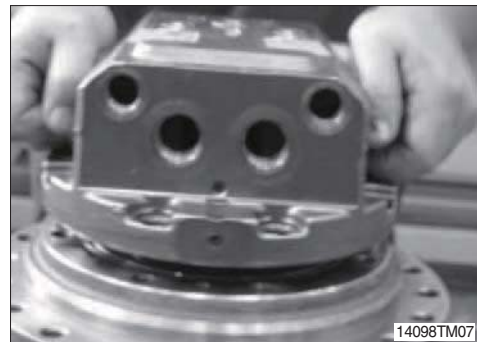

(5) Remove the parallel pin (42) from the spindle (101).



(6) Remove the O-ring (126) from the spindle (101).

※ Do not reuse the O-ring (126).



(7) Disassembling the rear flange (1) part

① Place the rear flange with the contact surface of the spindle upward.

② Remove the timing plate (9) from the rear flange (1).

※ When removing the timing plate, user can have difficulty of the removal due to the close adhesion of rear flange (1) and oil. Remove it after fitting a rod through the hole which is used when a casting is detached.

※ Be careful of the leakage due to both surface scratch if using a sharp tool.



③ Remove the parallel pin (41) from the rear flange (1).



- ④ Remove the ball bearing (50) from the rear flange (1).



(8) Disassembling the brake valve part

- ① Remove two plugs (24) from the rear flange (1).
- ※ User can work easily if sub-disassembly was done on the reversal table.
 - ※ Tools
 - Hexagon wrench 36
 - Torque wrench



- ② Take out two spring retainers (25), two springs (28) from the rear flange (1).
- ③ Remove the spool (23) from the rear flange (1).
- ※ Be careful not to damage the outer surface of the spool (23) and the sliding surface of the rear flange (1).
 - ※ Since the rear flange (1) and the spool (23) are of the selective fitting type, replace them together as a kit even if only one of the two parts is damaged.



- ④ Remove two plugs (26) from the rear flange (1).
- ※ User can work easily if sub-disassembly was done on the reversal table.
 - ※ Tools
 - Hexagon wrench 10



- ⑤ Remove the springs (30, 2EA), valves (27, 2EA) from rear flange (1).

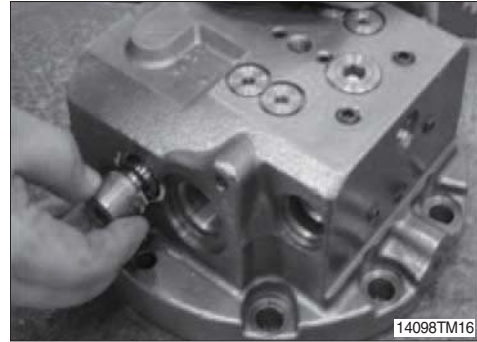

- ⑥ Remove the O-ring (37) from plug (24).
※ Do not reuse the O-ring (37).

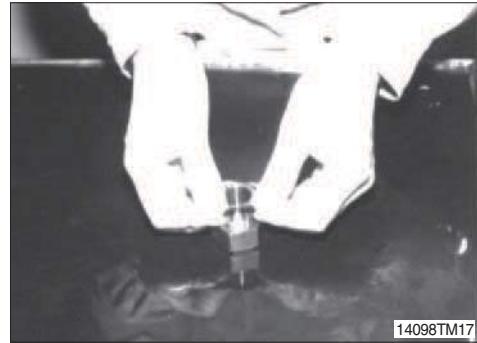

- ⑦ Remove the O-ring (36) from plug (26).
※ Do not reuse the O-ring (36).



(9) Disassembling the two speed change valve

- ① Remove the plug (63) from the rear flange (1).
※ User can work easily if sub-disassembly was done on the reversal table.
※ Tools
· Hexagon wrench 10



- ② Remove the spool (65) and spring (66) from rear flange (1).

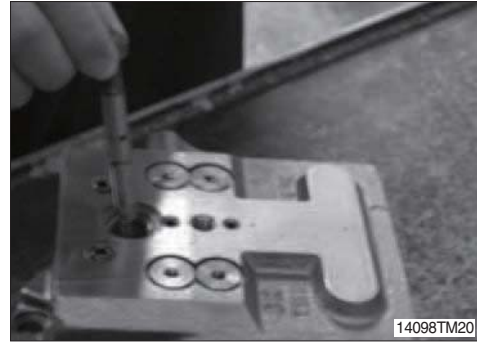

(10) Disassembling the plug (52).

- ① Do not remove plug (52) if it not to be necessary.
Disassembling the plug (52) if it was malfunction because of get mixed with dust.
Clean the plug (52) after disassembled.
- ※ Be careful not to drop the steel ball (68).

(11) Disassembling the parking brake valve (19)

- ① Mount the rear flange (1) on a working bench that the mounting side of the spindle (101) faces upward.
- ② Pushing valve seat (18) by a steel bar, disassemble ring (22) from rear flange (1).



- ※ Do not remove ring (22) if it not to be replace.
- ※ Do not reuse the ring (22), valve seat (18) and O-ring (33).

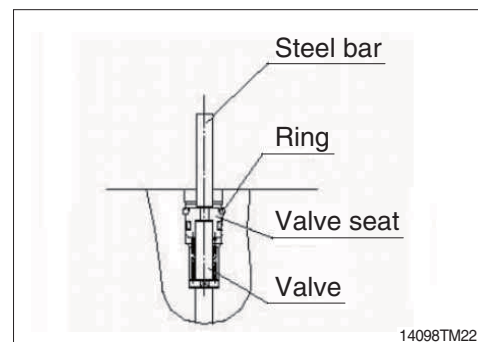

- ③ Remove the valve seat (18) by injecting compressed air from the access hole in the spindle (101) after caulking the hole of valve seat (18).

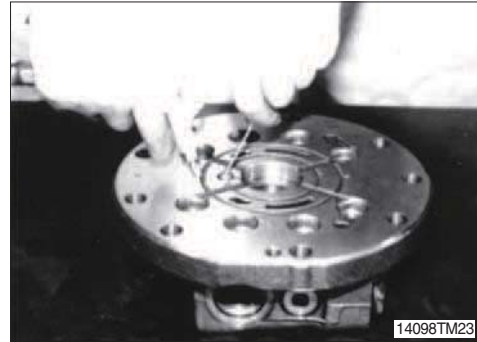

- ④ Remove the valve (19) and spring (20) from rear flange (1) downside hole with shaking lightly.

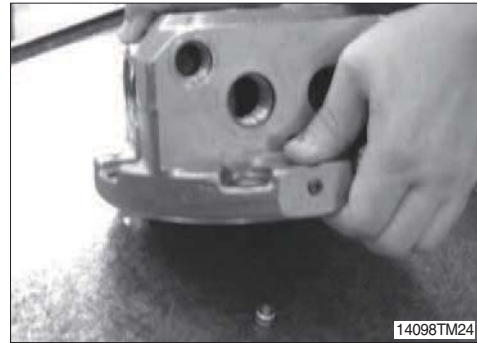

- ⑤ Remove the O-ring (33) and valve seat (18).
※ Do not reuse the O-ring (33).



(12) Disassembling the parking brake

- ① Remove the piston (12) by injecting compressed air from the parking brake access hole in the spindle (101).
※ Use the protection cover on the upper part of spindle (101) when users put the pressed air into suddenly. Otherwise part damage and accident might go on because the piston (12) is rushed out of the spindle (101).



- ② Remove the O-rings (35, 39) and backup rings (47, 48) from the piston (12).

※ Do not reuse O-rings (35, 39) and backup rings (47, 48) after removal.



(13) Disassembling the hydraulic motor part

- ① Lay the travel motor body on the side.

- ② Drain out the oil from the travel motor.

※ Place an oil receptacle under the travel motor to receive the oil flowing out as the motor is being laid on the side.

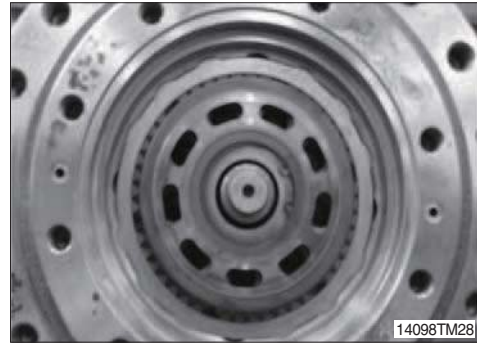

- ③ Hold the cylinder block (4) with both hands, and remove it from the shaft (2).

- ④ Remove the mating plates (16) and friction plates (15) from the cylinder block (4).

※ Before removal, hold the cylinder block (4) with both hands and turn it two to three times in a clockwise and a counterclockwise direction alternately to detach the shoe (6) from the swash plate (3).

※ Be careful that if an attempt is made to remove the cylinder block (4) without detaching the shoe (6) from the swash plate (3), then the piston, shoe and other parts that are connected to the cylinder block may come the cylinder loose and fall into the spindle (101).



(14) Disassembling the cylinder block kit

- ① Piston assembly [piston (5), shoe (6)] from the removed cylinder block (4).



- ② Piston (5) and shoe (6) from the removed retainer plate (7).



- ③ Thrust ball (8) from the removed cylinder block (4).



- ④ Roller (51, 5EA) from the removed cylinder block (204).

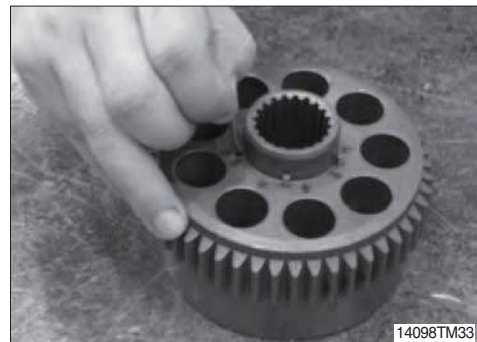

(15) Disassembling the spring of the cylinder block

- ① Put the cylinder block (4) on the pressurize jig.
 - ② Press the washer (10) with pressurize jig, and remove the spring (14) after snap ring (45) removed.
- ※ Put a vinyl cover on the sliding surface of cylinder block (4) for protection.
 - ※ Do not remove spring (14) if it not to be replace.



- ③ Remove the snap ring (45), washer (10), spring (14) and washer (10) from cylinder block (4).



(16) Disassembling the shaft

- ① Remove swash plate (3) from the shaft (2).
 - ② Remove shaft (2) from the spindle (101).
- ※ When separating the swash plate, separate and turn it by using hands to free from intervention of the stopper.



- ③ Remove speed selector piston assembly [piston (61) and shoe (62)] from the spindle [101] by feeding compressed air into the access hole in spindle (101).
 - ④ Remove parallel pins (42, 2EA) and pivots (67, 2EA) from the spindle (101).
 - ⑤ Remove roller bearing (49) from the spindle (101).
- ※ Piston assembly ; Piston (61), Shoe (62)
 - ※ Compressed air ; 3~5 kgf/cm² (43~71 psi)
 - ※ When piston (61) or shoe (62) is damaged, if exchange is necessary, they have to be exchanged together because the separation is impossible. Use the protection cover on the upper part spindle when users put the compressed air into suddenly. Otherwise part damage and accident might go on because the piston is rushed out of the spindle.



4. REASSEMBLY

4.1 GENERAL PRECAUTIONS

- 1) Reassemble in a work area that is clean and free from dust and dirt.
- 2) Handle parts with bare hands to keep them free of lint contaminants.
- 3) Repair or replace the damaged parts.
Each parts must be free of burrs its corners.
- 4) Do not reuse O-ring, oil seal and floating seal that were removed in disassembly. Provide the new parts.
- 5) Wash all parts thoroughly in a suitable solvent. Dry thoroughly with compressed air.
Do not use the cloths.
- 6) When reassembling oil motor components of travel motor, be sure to coat the sliding parts of the motor and valve with fresh hydraulic oil. (NAS class 9 or above)
- 7) Use a torque wrench to tighten bolts and plugs, to the torque specified as follows.

4.2 REASSEMBLY PROCEDURE

1) REASSEMBLE THE HYDRAULIC MOTOR PART

- (1) Install roller bearing (49) into the spindle (101).
- (2) Install pivots (67, 2EA), parallel pin (42, 2EA) and two speed piston assembly (61, 62) into the spindle (101).
- (3) Install shaft (2) into the roller bearing (49) assembled spindle (101).
※ Be careful not to damage the seal (3) of assembling part.



- (4) Lay the travel motor body on the side.
- (5) Apply lithium grease to the shaft (2)'s spline part.
- (6) Install swash plate (3) to the spindle (101).



(7) Reassemble the cylinder block kit

- ① Install washer (10), spring (14, 9EA), washer (10) and snap ring (45) in that order, into the cylinder block (4) inner part.
- ② Put the cylinder block (4) on the pressurize jig.



- ③ While pressing washer (10) by pressurize jig, install snap ring (45).
- ※ Put a vinyl cover on the sliding surface of the cylinder block (4) and timing plate (9) for protection.



(8) Reassemble the hydraulic motor

- ① Install roller (51, 5EA) to the pin hole of cylinder block (4).
- ② Install thrust ball (8) to the cylinder block (4).
- ③ Insert piston assembly [piston (61) and shoe (62), 9 set] into retainer plate (7).
- ※ After mounting, immerse the entire them in a working fluid.



- ④ Mount the piston assembly (9 set) into the cylinder block (4).
- ※ The retainer plate (7) must be in contact with the round part of thrust ball (8).



- ⑤ Install cylinder block (4) assembly to the shaft (2).
- ※ After fitting splines of both cylinder block (4) and shaft (2), assemble them.
- ※ After installing the cylinder (4), confirm whether it revolves or not by turning using both hands.
- ※ Motor is malfunction when it isn't revolve.



(9) Reassemble the parking brake

- ① Install mating plate (16) first and then a friction plate (15), one by one, into the grooves of the outer surface of the cylinder block (4).
- ※ Immerse the friction plates (15) in a working fluid before fitting them into the grooves.

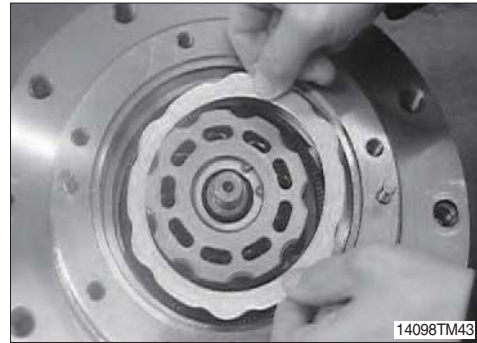

- ② Install two O-rings (35, 39) and two back up ring (47, 48) into O-ring grooves.
- ③ Mount a piston (12) in the spindle (101).
- ※ Apply a thin coat of grease to the O-rings (35, 39).
- ※ If the piston (12) does not fit into the spindle (101) because of the resistance of the O-ring, tap the edge of the piston (12) lightly and equally with a plastic hammer.
- ※ Be careful not to damage the O-ring and back up ring at this time.



2) REASSEMBLE THE REAR FLANGE (1) PART

(1) Reassemble the check valve

- ① Install O-ring (36, 2EA) on the plug (26, 2EA).
- ※ Apply grease to the O-ring (36).



- ② Install spring (30) and valve (27) into the plug (26).
- ③ Install plug (26) into the rear flange (1).
- ※ Install spring (30) and valve (27) into the plug (26), and then grease the spring (30) and the valve (27) and hand-lock the former.

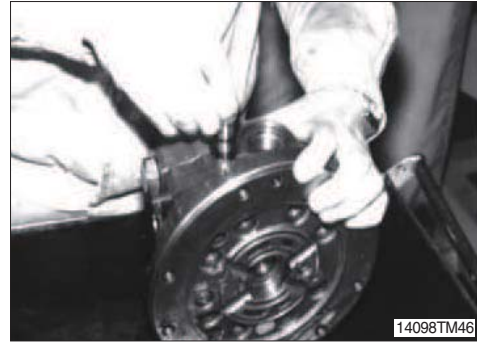

- ④ Install plug (26) in conjunction with the spring (30) and the valve (27) into the rear flange (1), and tighten the plug to the required torque.
- ※ Tightening torque : $17 \pm 2.6 \text{ kgf} \cdot \text{m}$ ($123 \pm 18.8 \text{ lbf} \cdot \text{ft}$)
- ※ Tools
 - Adapter for hexagon wrench 10
 - Torque wrench



- ⑤ Install spool (23) into the rear flange (1).
- ※ Before installing the spool (23), apply hydraulic oil to the spool. Be careful not to damage the spool's surface and the inner of rear flange (1).



- ⑥ Install O-ring (37) on the plug (24).
- Apply grease to the O-ring (37).

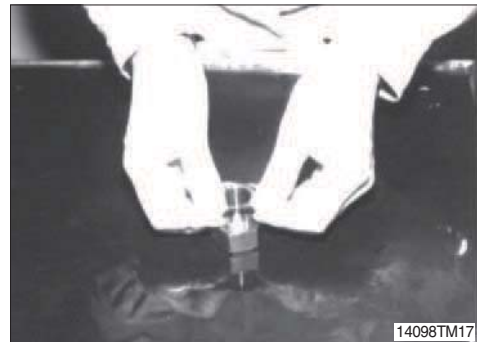

⑦ Install spring retainer (25) and spring (28) into the plug (24).

⑧ Install plug (24) into the rear flange (1).

⑨ Tighten the plug (24) to the required torque.

※ Tightening torque : 36 ± 5.4 kgf · m (260 ± 39 lbf · ft)

※ Socket (#36) / Torque for hexagon wrench.

※ Tools

· Hexagon socket 36

· Torque wrench



(2) Reassemble the two speed change valve

① Install spring (66) into the valve (65).

② Insert the valve (65) into the rear flange (1).

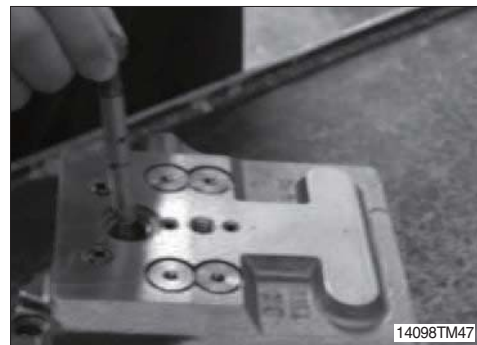

③ Insert a plug (63) into the rear flange (1).

※ Tightening torque : 13 ± 2.6 kgf · m (94 ± 18.8 lbf · ft)

※ Tools

· Adapter for hexagon wrench 10

· Torque wrench



(3) Reassemble the parking brake valve

① Install O-ring (33) on the valve seat (18).

※ Do not reuse the O-ring (33).



- ② Mount the rear flange (1) on a working bench that the mounting side of the spindle (101) faces upward.
- ③ Install valve (19), spring (20) and valve seat (18) in that order.

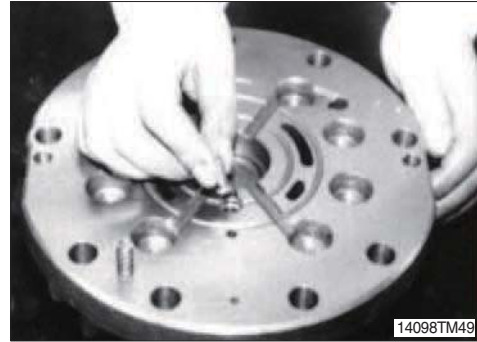

- ④ After new ring (22) bend somewhat and put the valve seat (18), then into the rear flange (1) ring's groove.
- ※ Do not reuse the ring (22).

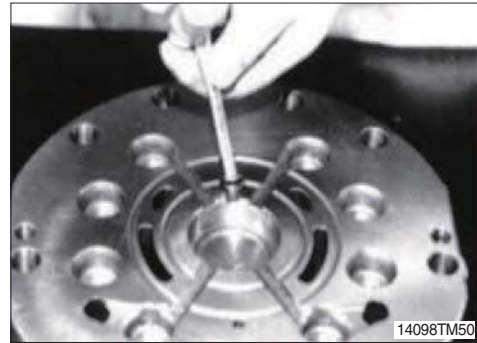

- ⑤ Install ball bearing (50) into the rear flange (1).
- ※ Apply hydraulic oil to the ball bearing (50).



- ⑥ Install parallel pin (41) into the pin hole of rear flange (1).



- ⑦ Install timing plate (9) into the rear flange (1).
※ Apply hydraulic oil to the contact surface of rear flange.



(4) Reassemble the rear flange (1) and spindle (101)

- ① Tilt the work bench 90° for travel motor reassembling.
② Insert the O-ring (75, 126) on the spindle (101).
※ Apply grease to the O-rings (75, 126) thinly.



- ③ Install parallel pins (42, 2EA) into the spindle (101).



- ④ Mount the rear flange (1) on the spindle (101).
※ When the rear flange (1) is mounted on the spindle (101), fix the spring (13) applied grease to not drop.



⑤ Tighten the socket bolt (43) into the spindle (101) to the required torque.

※ Tightening torque : $5.9 \pm 1.0 \text{ kgf} \cdot \text{m}$ ($42.7 \pm 7.2 \text{ lbf} \cdot \text{ft}$)

※ Tools

- Adapter for hexagon wrench 8
- Torque wrench

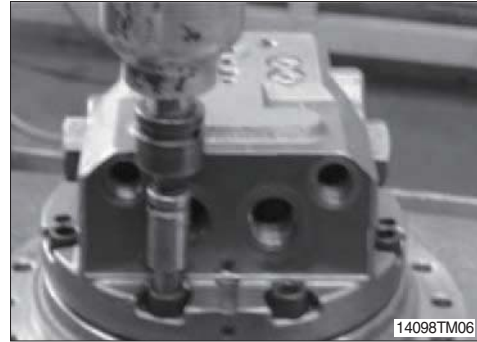

⑥ Tighten the plug (24) into the rear flange (1) to the required torque.

※ Tightening torque : $13 \pm 4.0 \text{ kgf} \cdot \text{m}$ ($94 \pm 28.9 \text{ lbf} \cdot \text{ft}$)

※ Tools

- Hexagon socket 36
- Torque wrench



⑦ Tighten the plug (26) into the rear flange (1) to the required torque.

※ Tightening torque : $36 \pm 1.5 \text{ kgf} \cdot \text{m}$
($260 \pm 10.8 \text{ lbf} \cdot \text{ft}$)

※ Tools

- Hexagon socket 10
- Torque wrench



3) REASSEMBLE THE REDUCTION GEAR ASSEMBLY

(1) Install floating seal (102) on the spindle (101).

※ Apply grease to the floating seal (102).



(2) Install angular bearing (125) and snap ring (106) into the hub (105).

※ Be careful for the insert direction.



(3) Insert the O-ring (130), the sealing (129) and floating seal (102) in the hub (105).

※ Apply grease to the floating seal (102) thinly.



(4) Install the spindle (101) into the hub (105) assembly.

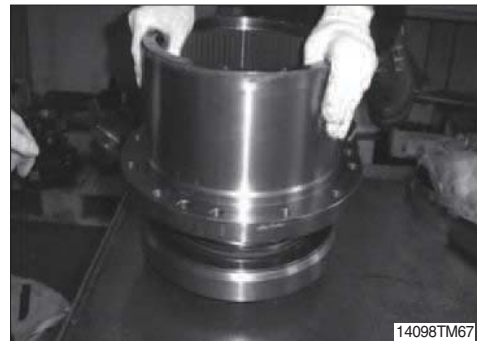

(5) Tighten the nut ring (103) and plug (104) into the hub (105) to the required torque.

※ Do not wind the seal tape to the plug (104).

※ Punch two place for not to loosen the plug (104).

※ Tightening torque : 3.5 ± 0.7 kgf · m (25.3 ± 5.1 lbf · ft)

· Hexagon socket 8

· Torque wrench



(6) Install thrust washer (109) and collar (112) into the hub (105).



(7) Install needle bearing (111) planetary gear F (108), thrust washer (109), thrust plate F (113) and screw (110) into the hub (105).

- ※ Tightening torque : 0.83 kgf · m (6.0 lbf · ft)
- Hexagon socket 5
- Torque wrench



(8) Install sun gear (114) and holder assembly, then insert needle bearing (118) and planetary gear R (117) into the hub (105).

- ※ Holder assembly : holder (116) + spring pin (120) + inner race (119)



(9) Install drive gear (121) and thrust plate R (122) into the hub (105).



- (10) Install cover (123), thrust plate (150), plug (301, 128) and socket bolt (124) into the hub (105).
※ Apply grease to the cover (123) after installed O-ring (127).



(11) Pressing the oil seal

- ① Insert the oil seal (32) by hit the pressurize jig with plastic hammer.
※ Apply grease to the seat of oil seal (32).

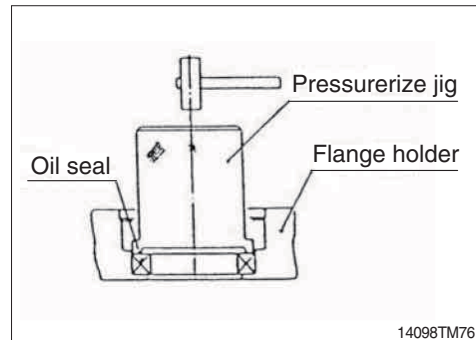

3.4 CHECKING FACTS AFTER ASSEMBLY

1) AIR TEST OF REDUCTION GEAR

Disassemble plug (128) of reduction gear part. When compressed air (0.3 kgf/cm^2) is inserted that in water during the 2 minutes, it should be not happened air bubble.

Fill the gear oil.

- Oil amount : 3.0 liter (0.79 U.S.gallon)

2) AIR TEST OF HYDRAULIC MOTOR

One port should be opened, the others port should be closed. When compressed air (3 kgf/cm^2) is inserted opened port in water during the 2 minutes, it should be not happened air bubble.

Fill the hydraulic oil.

- Oil amount : 0.55 liter (0.15 U.S.gallon)

■ TRAVEL MOTOR (TYPE 2)

1. REMOVAL AND INSTALL

1) REMOVAL

- (1) Swing the work equipment 90° and lower it completely to the ground.
- (2) Operate the control levers and pedals several times to release the remaining pressure in the hydraulic piping.
- (3) Loosen the breather slowly to release the pressure inside the hydraulic tank.

▲ Escaping fluid under pressure can penetrate the skin causing serious injury.

- ※ When pipes and hoses are disconnected, the oil inside the piping will flow out, so catch it in oil pan.
- (4) Remove the track shoe assembly.
For details, see **removal of track shoe assembly**.
 - (5) Remove the cover.
 - (6) Remove the hose.
 - ※ Fit blind plugs to the disconnected hoses.
 - (7) Remove the bolts and the sprocket.
 - (8) Sling travel device assembly (1).
 - (9) Remove the mounting bolts (2), then remove the travel device assembly.
 - Weight : 185 kg (410 lb)

2) INSTALL

- (1) Carry out installation in the reverse order to removal.
- (2) Bleed the air from the travel motor.
 - ① Remove the air vent plug.
 - ② Pour in hydraulic oil until it overflows from the port.
 - ③ Tighten plug lightly.
 - ④ Start the engine, run at low idling, and check oil come out from plug.
 - ⑤ Tighten plug fully.
- (3) Confirm the hydraulic oil level and check the hydraulic oil leak or not.

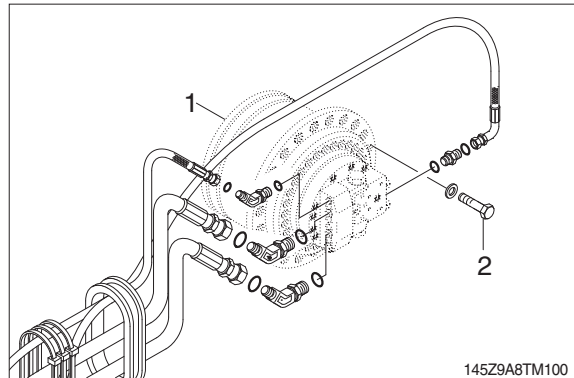

2. SPECIFICATION

1) STRUCTURE

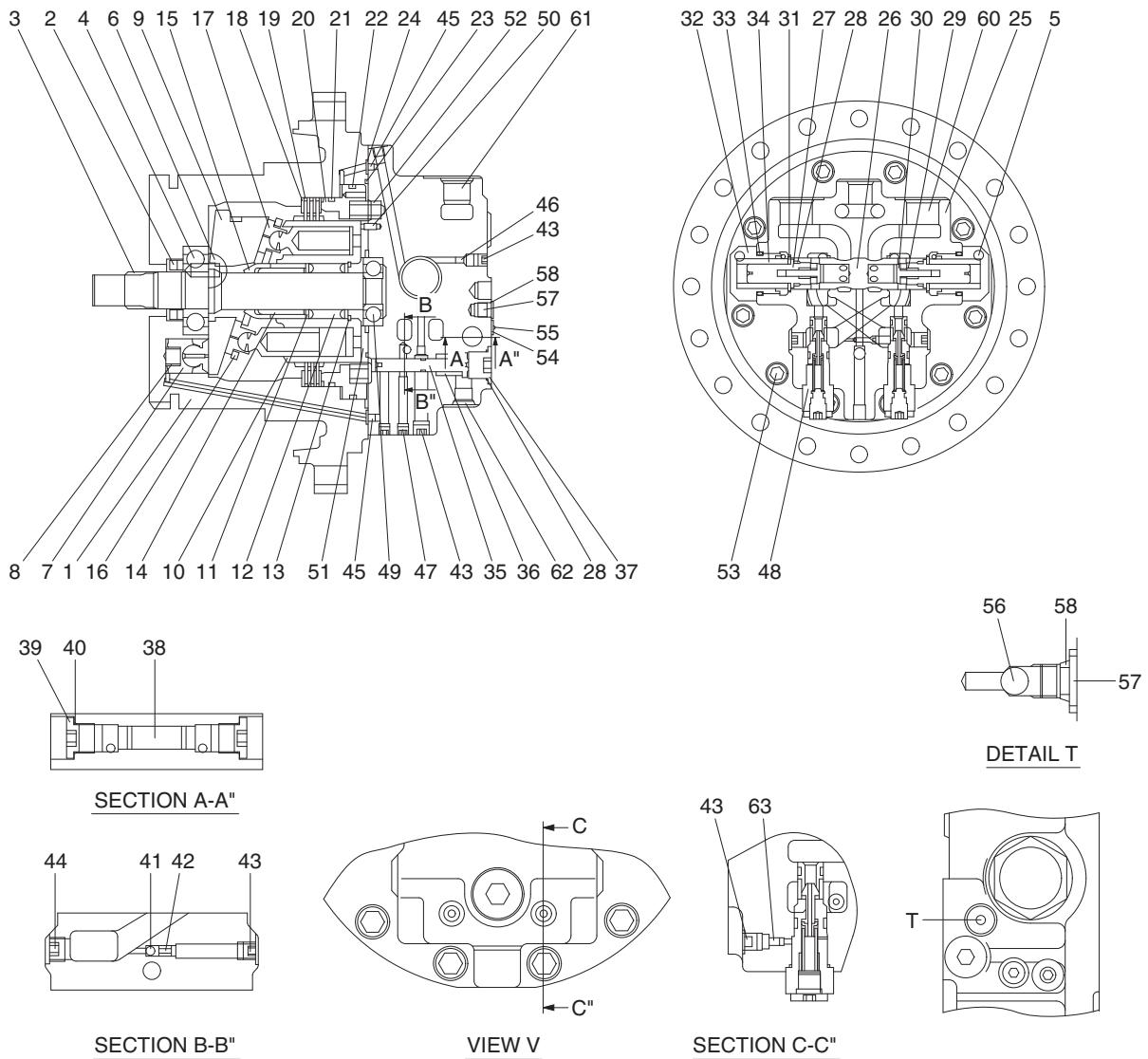

1 Shaft casing	17 Piston assy	33 O-ring	49 Bearing
2 Oil seal	18 Steel plate	34 Spring	50 Pin
3 Shaft	19 Friction plate	35 Spool	51 Valve plate
4 Bearing	20 Brake piston	36 Spring	52 Spring
5 Pin	21 Ring	37 Plug	53 Wrench bolt
6 Swash ball	22 Ring	38 Piston	54 Name plate
7 Swash piston	23 O-ring	39 Plug	55 Rivet
8 Spring	24 O-ring	40 O-ring	56 Steel ball
9 Swash plate	25 Valve casing	41 Steel ball	57 Plug
10 Cylinder block	26 Main spool	42 Orifice	58 O-ring
11 Spring seat	27 Plug	43 Plug	60 Plastic plug
12 Spring	28 O-ring	44 Plug	61 Plastic plug
13 Snap ring	29 Spring	45 Orifice	62 Plastic plug
14 Pin	30 Check	46 Orifice	63 Orifice
15 Ball guide	31 Plate	47 Plug	
16 Set plate	32 Plug	48 Relief valve assy	

145Z9A2TM02

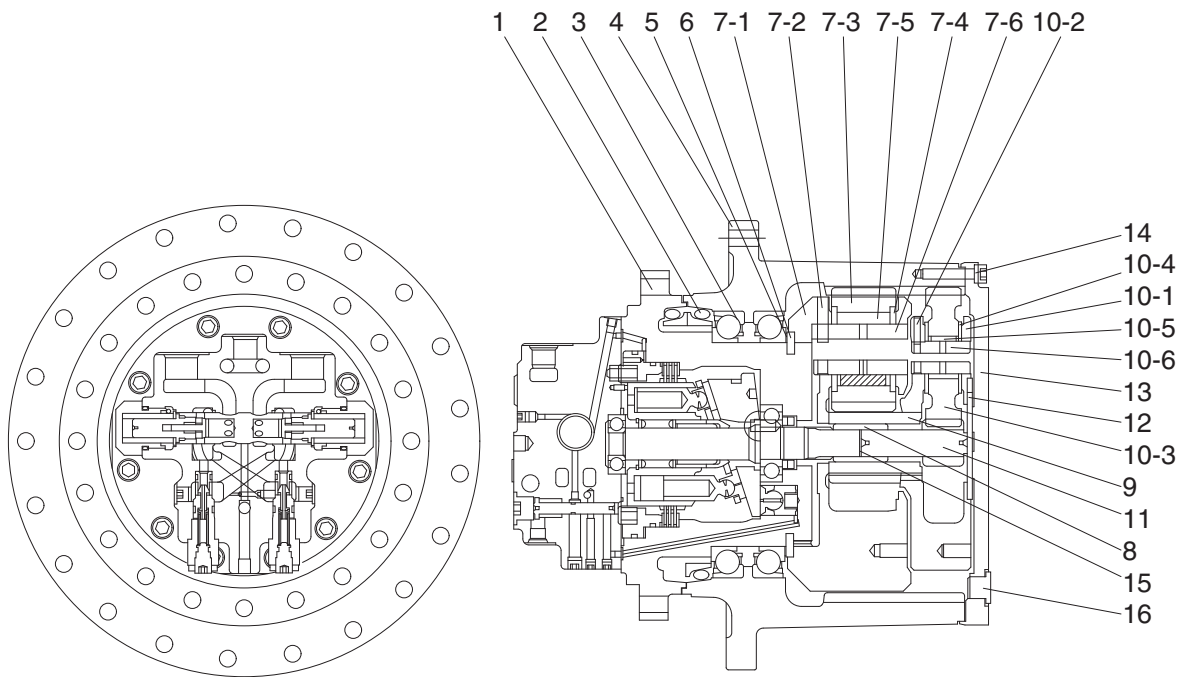

145Z9A2TM02A

- | | | |
|----------------------|-----------------------|----------------|
| 1 Spindle | 7-4 Washer 2 | 10-5 Bearing 1 |
| 2 Floating seal | 7-5 Bearing 2 | 10-6 Pin 1 |
| 3 Ball bearing | 7-6 Pin 2 | 11 Sun gear 1 |
| 4 Housing | 8 Coupling | 12 Plate 1 |
| 5 Shim | 9 Sun gear 2 | 13 Cover |
| 6 Shim | 10 Carrier assy 1 | 14 Bolt |
| 7 Carrier assy 2 | 10-1 Carrier 1 | 15 Snap ring |
| 7-1 Carrier 2 | 10-2 Spring pin 1 | 16 Plug |
| 7-2 Spring pin 2 | 10-3 Planetary gear 1 | |
| 7-3 Planetary gear 2 | 10-4 Washer 1 | |

2) TOOL AND TIGHTENING TORQUE

(1) Tools

Name of tools	B (mm)	Name of part applied
Hexagonal L-Wrench	4	Plug (42, 45, 46, 47)
	6	Plug (43, 44)
	8	Plug (39)
	10	Plug (37, 57), Wrench bolt (53)
Socket wrench/ spanner	24	Relief plug (48)
	41	Main spool plug (32)
Snap ring plier (for holes, axis)		∅ 42 (13)
Hammer		Ball bearing (49), Pin (50)
Torque wrench		Size : 5 kgf · m, 100 kgf · m
Jig for oil seal assembling		Oil seal (2)
Heating tool for bearing		Parking spring (20)

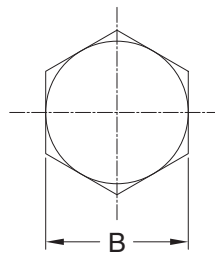
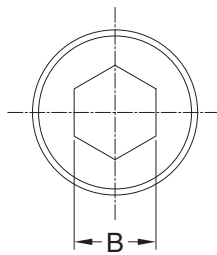

Size B

145Z9A8TM99

(2) Tightening torque

Item no.	Part name	Size	B (mm)	Torque	
				kgf · m	lbf · ft
25	Wrench bolt	-	-	68	491.8
32	Main spool plug	M36	41	45	325.5
37	Plug	PF 3/8	10	6	43.4
39	Plug	PF 1/4	8	3	21.7
42, 45, 46, 47	Plug	PT 1/16	4	0.7~1.1	5.1~8.0
43	Plug	PT 1/8	6	1.25	9.0
48	Relief valve plug	PF 1/2	24	10	72.3
53	Wrench bolt	M12×30	10	10.4	75.2

2. DISASSEMBLING AND ASSEMBLING

1) GENERAL INSTRUCTIONS

- (1) Generally, hydraulic equipment is precisely manufactured and clearances between each parts are very narrow. Therefore, disassembling and assembling works should be performed on the clean place where dusts hardly gather. Tools and kerosene to wash parts should also be clean and handled with great care.
 - (2) When motor is removed from the host machine, wash around the ports sufficiently and put the plugs so that no dust and/or water may invade. Take off these plugs just before the piping works when re-attach it to the host machine.
 - (3) Before disassembling, review the sectional drawing and prepare the required parts, depending on the purpose and the range of disassembling.
Seals, O-rings, etc., if once disassembled, are not reusable.
There are some parts that should be replaced as a subassembly.
Consult with the parts manual in advance.
 - (4) The piston can be inserted to whichever cylinder block for the initial assembling.
However, their combination should not be changed if they are once used. To reuse them, put the matching mark on both pistons and cylinder block before disassembling.
- ▲ Take great care not to pinch your hand between parts while disassembling nor let fall parts on your foot while lifting them.**

2) DISASSEMBLING MOTOR UNIT

- (1) Disassemble relief valve (48) from valve casing (25) using a torque wrench.

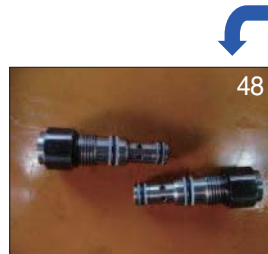

145Z9A8TM01



145Z9A8TM02

- (2) Disassemble wrench bolt (53) (M12 × 30) and take out valve casing sub assembly.



145Z9A8TM03

- (3) Remove parking spring (52) - 12EA.



145Z9A8TM04

- (4) Remove O-ring (23).



145Z9A8TM05

(5) Disassemble brake piston (20) using a jig.



(6) Disassemble friction plate (19)-3EA, steel plate (18)-4EA.

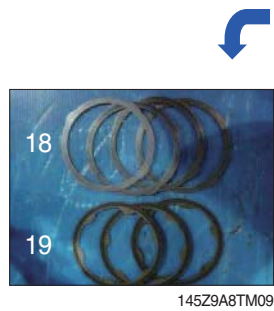

(7) Remove the cylinder block kit (II).

※ It is easier to work by placing the shaft casing (1) horizontal.



(8) Disassemble cylinder block (10), ball guide (15), set plate (16), piston assy (17), pin (14) from cylinder block kit (II).

Press spring (12) using a jig and take out snap ring (14) using a plier.

Disassemble snap ring (13), spring seat (11), spring (12) from cylinder block kit (II).



145Z9A8TM13



145Z9A8TM14



145Z9A8TM15



145Z9A8TM16

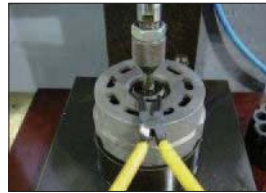

145Z9A8TM17

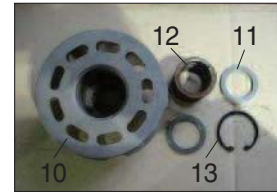

145Z9A8TM18

(9) Disassemble swash plate (9).



145Z9A8TM19

(10) Disassemble swash ball (6).



145Z9A8TM20

(11) Disassemble shaft (3) from shaft casing (1).



- After disassembled shaft (3) is placed on a jig, top of shaft is pressed down using a press. It can remove ball bearing (4) portion.

※ Remove ball bearing (4) in case it is replaced only.

- Dismantled bearing can't be reused.

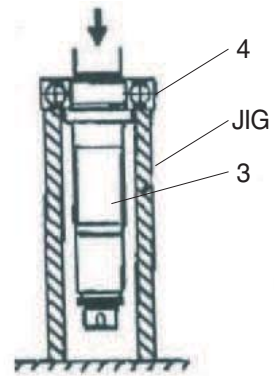

(12) Disassemble swash piston (7), spring (8) into shaft casing(1).



(13) Disassemble oil seal (2) from shaft casing (1) using a tool.

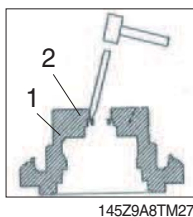

(14) Disassemble valve plate (51) and ball bearing (49) from valve casing (25).



145Z9A8TM30



145Z9A8TM31



145Z9A8TM32

(15) Disassemble plug (47) from valve casing (25).



145Z9A8TM33

(16) Disassemble plug (37) from valve casing (25) using a torque wrench and disassemble two speed control spool (35), spring (36) in regular sequence.

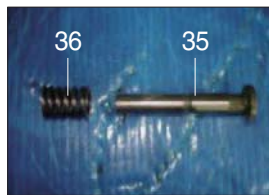

145Z9A8TM34

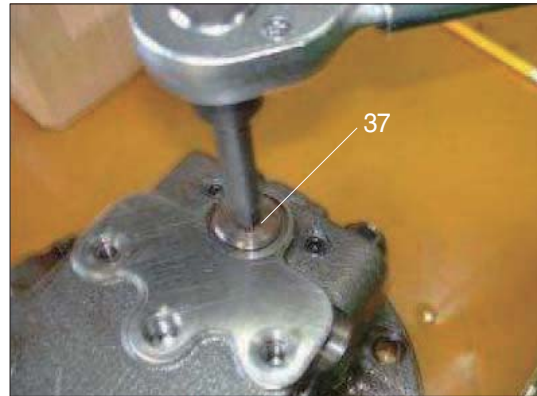

145Z9A8TM35

(17) Disassemble main spool plug (32) from valve casing (25) using a torque wrench and disassemble spring (34), plate (31), main spool (26) in regular sequence.



145Z9A8TM36



145Z9A8TM37

(18) Disassemble plug (43) from valve casing (25) and then disassemble orifice (42), steel ball (41) one by one.



145Z9A8TM38



145Z9A8TM39

(19) Disassemble plug (39), relief valve damping piston (38) from valve casing (25).



145Z9A8TM40

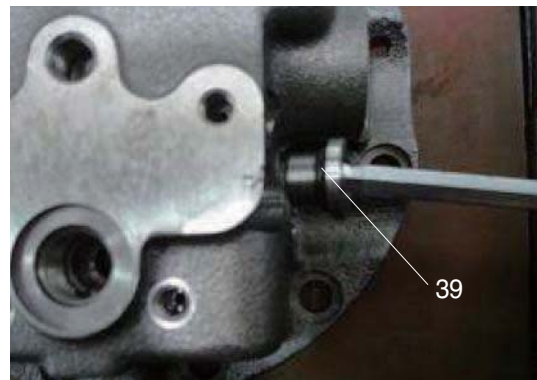

145Z9A8TM41

(20) Disassemble plug (43) from valve casing (25) and disassemble orifice (63).



145Z9A8TM42

(21) Disassemble plug (57), steel ball (56) from valve casing (25).



145Z9A8TM43



145Z9A8TM44

3) ASSEMBLING MOTOR UNIT

- (1) Put oil seal into shaft casing (1) using a jig.
 ※ Caution direction of oil seal.



145Z9A8TM45



145Z9A8TM46

- (2) Assemble swash spring (8) into shaft casing (1) and put swash piston (7) into shaft casing (1).



145Z9A8TM47



145Z9A8TM48

- (3) Press the ball bearing (4) into shaft (3) after preheating of ball bearing (4).

- ① Induction heating apparatus temperature : 100°C
- ② Be careful not to damage the sliding surface for the seal on the shaft.



145Z9A8TM49



145Z9A8TM50



145Z9A8TM51

- (4) Assemble shaft into shaft casing (1).

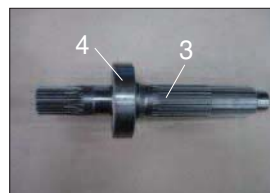

145Z9A8TM52



145Z9A8TM53

(5) Assemble swash ball (6)-2EA.



145Z9A8TM54

(6) Apply grease to swash plate (9) and assemble swash plate (9) into shaft casing (1).



145Z9A8TM55



145Z9A8TM56

(7) Slant the shaft casing (1) and then assemble cylinder block kit (II).

- Assemble spring seat (11), spring (12), spring seat (11) into cylinder block kit (II) in regular sequence.

Push down spring(12) and then assemble snap ring (13) into gap of cylinder block(10) using a plier.

- Assemble pin (14), ball guide (15), set plate (16), piston assy (17) into cylinder block (10) in regular sequence.



145Z9A8TM57

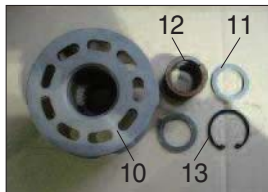

145Z9A8TM58



145Z9A8TM59



145Z9A8TM60



145Z9A8TM61



145Z9A8TM62



145Z9A8TM63



(8) Assemble friction plate (19), steel plate (18) into cylinder block in regular sequence.
Friction plate : 3 EA
Steel Plate : 4 EA



(9) Assemble parking piston (20) into shaft casing (1) using a jig.

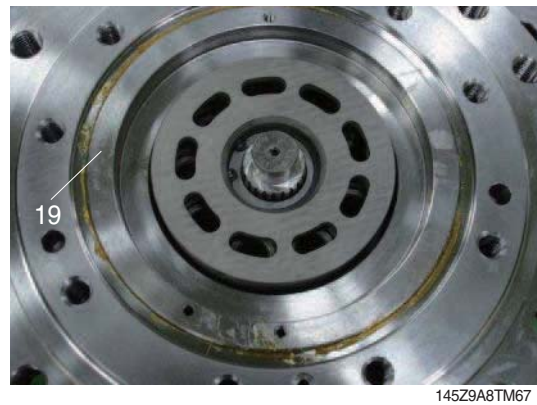

(10) Put O-ring (23) into shaft casing (1).
Apply the grease to O-ring.



(11) Put spring (36), two speed control spool (35) into valve casing (25) in regular sequence and assemble plug (37) into valve casing (25) using a torque wrench.

- Tighten torque : 10 kgf-m (72.3 lbf-ft)

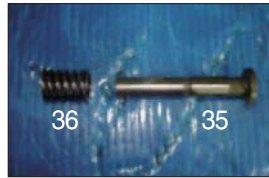

145Z9A8TM70

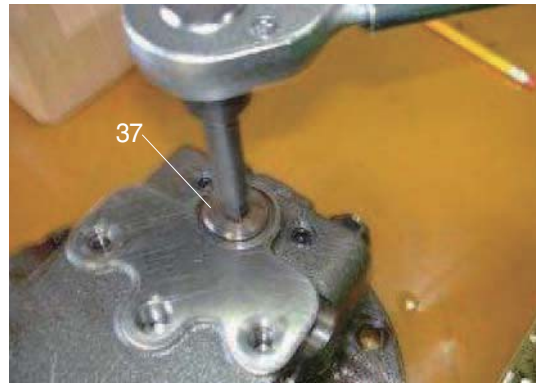

145Z9A8TM71

(12) Assemble check (30), spring (29), plug (27) into main spool (26) in regular sequence.

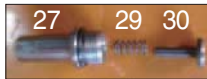

145Z9A8TM72



145Z9A8TM73



145Z9A8TM74



145Z9A8TM75

(13) Put the main spool (26) into valve casing (25) and assemble plate (31), spring (29) into it. Tighten main spool plug (32) using a torque wrench.

- Tighten torque : 45 kgf-m (325.5 lbf-ft)



145Z9A8TM76

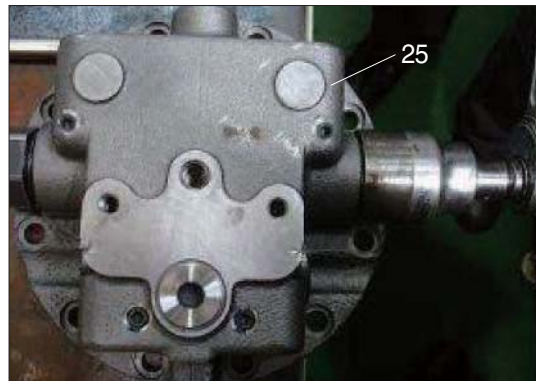

145Z9A8TM77

(14) Put relief valve damping piston (38) into valve casing (25) and assemble plug (39) into valve casing (25).

- Tighten torque : 6 kgf-m (43.4 lbf-ft)



145Z9A8TM78

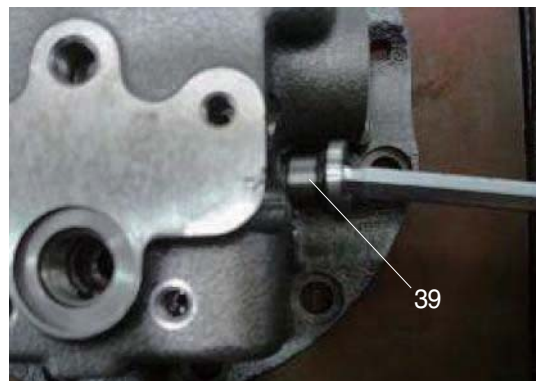

145Z9A8TM79

- (15) Put steel ball (41), orifice (42) into valve casing (25) and tighten the plug (43).
· Tighten torque : 1.25 kgf-m (9.0 lbf-ft)



145Z9A8TM80



145Z9A8TM81

- (16) Put steel ball (56) into valve casing (25) and tighten the plug (57).
· Tighten torque : 1.25 kgf-m (9.0 lbf-ft)



145Z9A8TM82



145Z9A8TM83

- (17) Assemble orifice (63) into valve casing (25) and tighten the plug (43).
· Tighten torque : 1.25 kgf-m (9.0 lbf-ft)



145Z9A8TM84

- (18) Assemble orifice (63) into valve casing (25) and tighten the plug (47).
· Tighten torque : 0.7~1.1 kgf-m
(5.1~8.0 lbf-ft)



145Z9A8TM85

(19) Assemble pin (50) into valve casing (25).

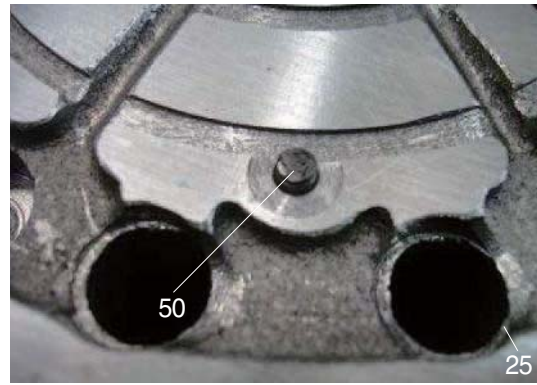

145Z9A8TM86

(20) Assemble pin (5) into valve casing (25).



145Z9A8TM87

(21) Assemble ball bearing (49) into valve casing (25).



145Z9A8TM88

(22) Apply grease on the face of valve plate and assemble valve plate (51) into valve casing (25).



145Z9A8TM89

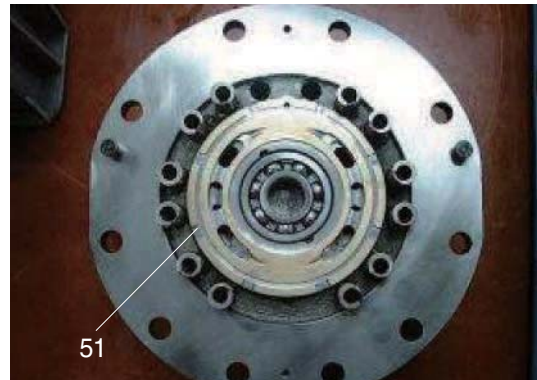

145Z9A8TM90

(23) Apply grease to brake spring (52)-12EA and assemble brake spring (52)-12EA into valve casing (25).



145Z9A8TM91

(24) Assemble valve casing (25) into shaft casing (1) and tighten the wrench bolt (53) using a torque wrench.

- Tighten torque : 10.4 kgf-m (75.2 lbf-ft)



145Z9A8TM92

(25) Assemble relief valve (48) into valve casing (25) using a torque wrench.

- Tighten torque : 10 kgf-m (72.3 lbf-ft)



145Z9A8TM93



145Z9A8TM94

4) DISASSEMBLING REDUCTION GEAR

(1) Loose plug (26)-3EA and drain reduction oil.



145Z9A8TR02

(2) Loose wrench bolt (25) using a tool.



145Z9A8TR03

(3) Disassemble end cover (24).



145Z9A8TR04

(4) Disassemble trust plate (23).



145Z9A8TR05



145Z9A8TR06

(5) Disassemble driver gear (16).



(6) Disassemble carrier No.1 (17) sub assy.
※ Assemble eyebolt into carrier No.1 tap hole and disassemble carrier No.1 (17) sub assy using a hoist.



(7) Disassemble carrier No.1 sub assy.
※ Remove spring pin No.1 (22) from carrier No.1 (17) and planetary gear No.1 (18), washer No.1 (19), needle bearing No.1 (20), carrier pin No.1 (21) in regular sequence.

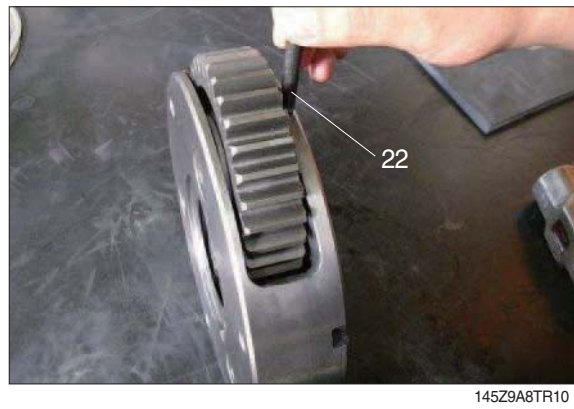

- (8) Disassemble carrier No.2 (7) sub assy.
 ※ Assemble eyebolt into carrier No.2 tap hole and disassemble carrier No.2 (7) sub assy using a hoist.



145Z9A8TR15

- (9) Disassemble carrier No.2 (7) sub assy.
 ※ Remove spring pin No.2 (12) from carrier No.2 (7) and disassemble planetary gear No.2 (8), washer No.2 (9), needle bearing No.2 (10), carrier pin No.2 (11) in regular sequence.



145Z9A8TR16



145Z9A8TR17



145Z9A8TR18



145Z9A8TR19

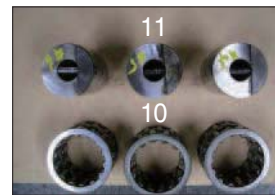

145Z9A8TR20

- (10) Push down ring gear (4) using a jig and disassemble shim (6).



145Z9A8TR21



145Z9A8TR22

(11) Disassemble ring gear sub assy (4) into motor assy.

- ※ Assemble eye bolt into tap hole of ring gear sub assy (4) and disassemble ring gear sub assy (4) using a hoist.



145Z9A8TR23

(12) Disassemble floating seal (2) from ring gear sub assy (4).



145Z9A8TR24



145Z9A8TR25

(13) Disassemble angular bearing (3) from ring gear sub assy (4).

- ※ Be careful not to damage the parts using a hammer.

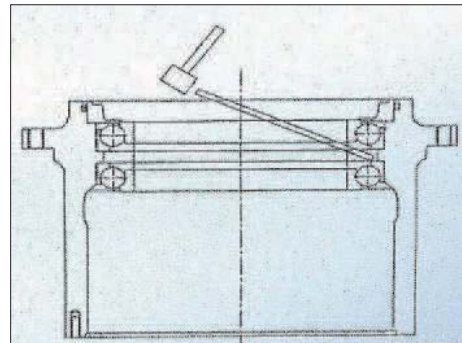

145Z9A8TR26

4) ASSEMBLING REDUCTION GEAR

Before assembling please observe following item.

- Wash all parts cleanly using solvent and dry all parts perfectly using compressed air.
- Check metal dust in casing and cleansing solution.
- Before application packing, please remove oil certainly.
- Before insert needle bearing, apply grease to bearing inlet enough.
- Apply lubricant to rotation part and sliding part.
- Damaged part or discolored part exchanges by new parts.

(1) Assemble hub

- ① Place the motor assy on the bench and assemble floating seal (2) into motor (1) using a jig.



145Z9A8TR27



145Z9A8TR28

- ② Remove completely the oil of surface that O-ring and O-ring contact.

- Dry completely the floating seal.
- After assembling the floating seal, coat lubricant to the sliding surface of the floating seal.

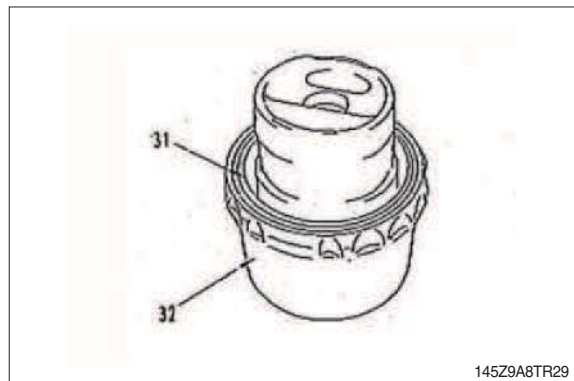

145Z9A8TR29

(2) Press angular bearing (3) into ring gear (4) using a jig.



145Z9A8TR30

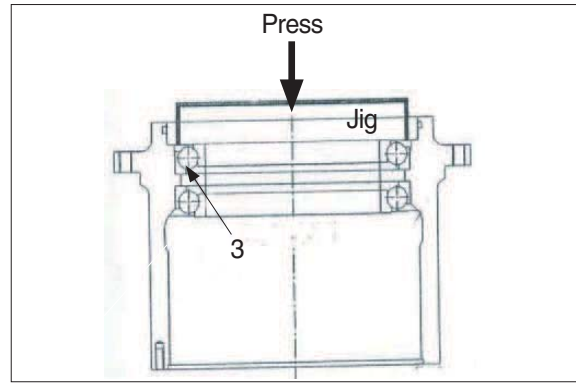

145Z9A8TR31

(3) Assemble floating seal (2) into ring gear (4) using a jig.



145Z9A8TR32



145Z9A8TR33

(4) Assemble ring gear sub assy (4) into motor assy using a assembly equipment.



145Z9A8TR34

(5) Push down ring gear (4) using a jig and assemble shim (6).

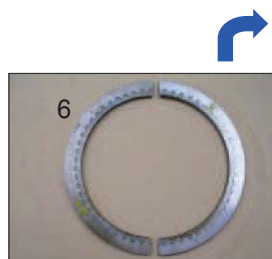

145Z9A8TR35



145Z9A8TR36

(6) Assemble carrier No.2 sub assy.

- Assemble planetary gear No.2 (8), washer No.2 (9), needle bearing No.2 (10) and carrier pin No.2 (11) into carrier No.2 (7) in regular sequence.
Assemble spring pin No.2 (12).
- Assemble spring pin No.2 (12) and caulk spring pin into pin hole.

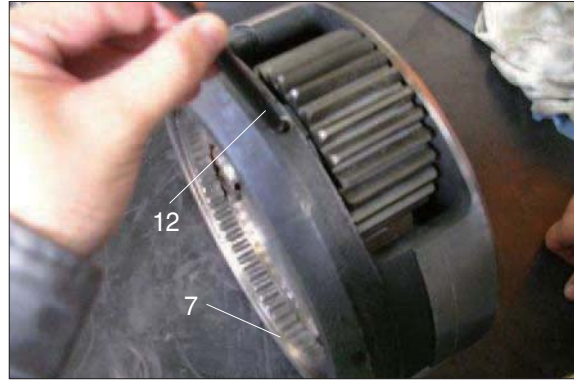

145Z9A8TR37



145Z9A8TR38



145Z9A8TR39



145Z9A8TR40

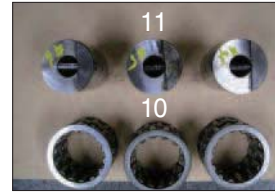

145Z9A8TR41



(7) Disassemble carrier No.2 (7) sub assy.

- Assemble eyebolt into carrier No.2 and assemble carrier No.2 (7) sub assy into ring gear using hoist.



145Z9A8TR42

(8) Disassemble carrier No.2 (7) sub assy.

- Assemble planetary gear No.1 (18), washer No.1 (19), needle bearing No.1 (20) and carrier pin No.1 (21) into carrier No.1 (17) in regular sequence.
Assemble spring pin No.1 (22)
- Assemble spring pin No.1 (22) and caulk spring pin into pin hole.

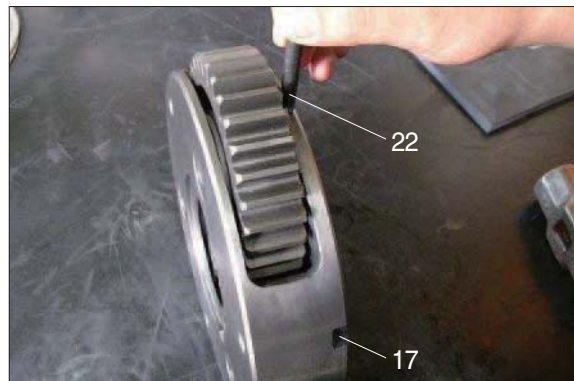

145Z9A8TR43



145Z9A8TR44



145Z9A8TR45



145Z9A8TR46



145Z9A8TR47



- (9) Assemble carrier No.1 (17) sub assy.
- Assemble eyebolt into carrier No.1 and assemble carrier No.1 (17) sub assy into ring gear using hoist.



145Z9A8TR48

- (10) Assemble driver gear(16).



145Z9A8TR49



145Z9A8TR50

- (11) Assemble trust plate (23).



145Z9A8TR51



145Z9A8TR52

- (12) Assemble end cover (24).



145Z9A8TR53

(13) Tighten wrench bolt (25) using a air impact.

- Tighten torque : 68 kgf-m (491.8 lbf-ft)



(14) Adjust control lever to be sunk the product under the test oil and then check the air leak.

- *TEST : Air pressure 0.7 kgf/cm² × 30sec

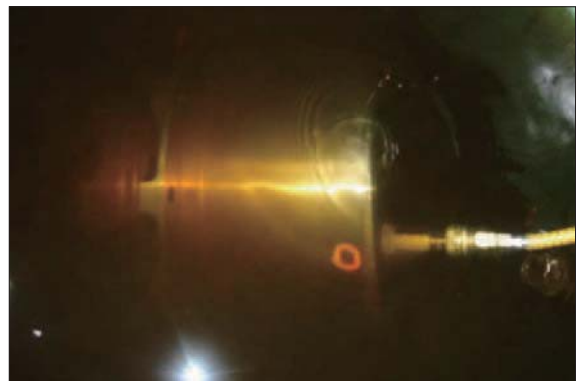

(15) Inject gear oil and assemble plug (26)-3EA.

- Volume of gear oil : 2.2 ℓ
- Tightening torque : 10 kgf-m (72.3 lbf-ft)



■ TRAVEL MOTOR (TYPE 3, 4)

1. REMOVAL AND INSTALL

1) REMOVAL

- (1) Swing the work equipment 90° and lower it completely to the ground.
- (2) Operate the control levers and pedals several times to release the remaining pressure in the hydraulic piping.
- (3) Loosen the breather slowly to release the pressure inside the hydraulic tank.

▲ Escaping fluid under pressure can penetrate the skin causing serious injury.

※ When pipes and hoses are disconnected, the oil inside the piping will flow out, so catch it in oil pan.

- (4) Remove the track shoe assembly.
For details, see **removal of track shoe assembly**.
- (5) Remove the cover.
- (6) Remove the hose.
※ Fit blind plugs to the disconnected hoses.
- (7) Remove the bolts and the sprocket.
- (8) Sling travel device assembly (1).
- (9) Remove the mounting bolts (2), then remove the travel device assembly.
· Weight : 140 kg (310 lb)

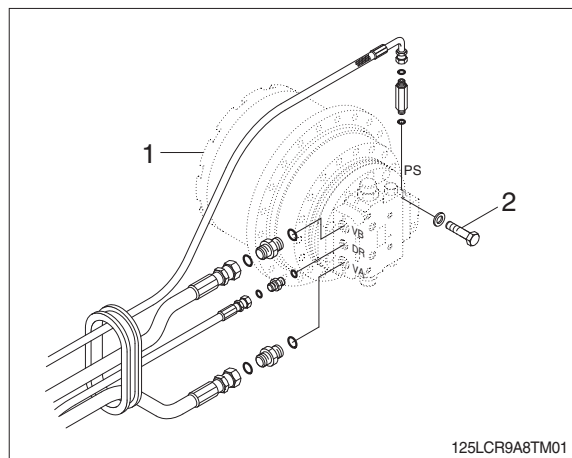

2) INSTALL

- (1) Carry out installation in the reverse order to removal.
- (2) Bleed the air from the travel motor.
 - ① Remove the air vent plug.
 - ② Pour in hydraulic oil until it overflows from the port.
 - ③ Tighten plug lightly.
 - ④ Start the engine, run at low idling, and check oil come out from plug.
 - ⑤ Tighten plug fully.
- (3) Confirm the hydraulic oil level and check the hydraulic oil leak or not.

2. TRAVEL MOTOR

1) STRUCTURE

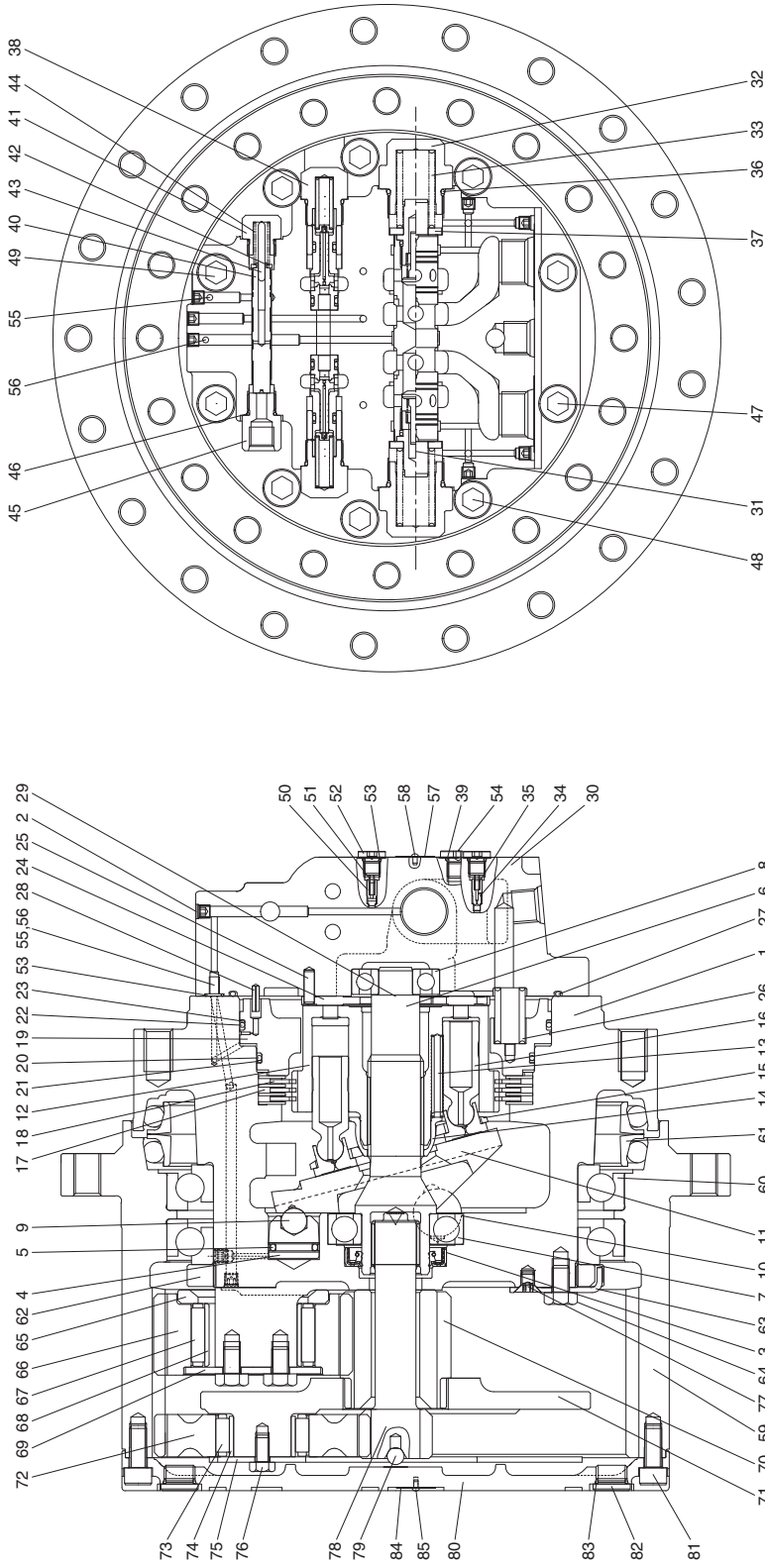

1	Casing	52	Plug	69	Thrust washer No. 2
2	Plug	53	O-ring	70	Sun gear No.2
3	Oil seal	54	Plug	71	Carrier No. 1
4	Piston	55	Restrictor	72	Planetary gear No.1
5	Piston seal	56	Restrictor	73	Needle bearing No.1
6	Shaft	57	Name plate	74	Inner race No. 1
7	Front ball bearing	58	Rivet	75	Thrust plate No. 1
8	Rear ball bearing	59	Ring gear	76	Hexagon head bolt
9	Steel ball	60	Bearing	77	Countersunk head screw
10	Steel ball	61	Floating seal assy	78	Sun gear No.1
11	Swash plate	62	Nut ring	79	Steel ball
12	Cylinder block	63	Lock plate	80	Cover
13	Spring	64	Hexagon head bolt	81	Hex socket head bolt
14	Ball guide	65	Thrust plate No. 2	82	Plug
15	Retainer plate	66	Planetary gear No.2	83	O-ring
16	Piston assy	67	Needle bearing No.2	84	Name plate
17	Friction plate	68	Inner race No. 2	85	Rivet
18	Separated plate	35	Spring		
19	Parking piston	36	O-ring		
20	O-ring	37	Spring seat		
21	Back up ring	38	Relief valve assy		
22	O-ring	39	O-ring		
23	Back up ring	40	Spool		
24	Valve plate	41	Plug		
25	Spring pin	42	Spring seat		
26	Spring	43	Parallel pin		
27	O-ring	44	Spring		
28	Spring pin	45	Connector		
29	Parallel pin	46	O-ring		
30	Rear cover	47	Hexagon socket head bolt		
31	Main spool assy	48	Hexagon socket head bolt		
32	Cover	49	Hexagon socket head bolt		
33	Spring	50	Check valve		
34	Restrictor	51	Spring		

2) DISASSEMBLY

- (1) Choose a clean place, remove contaminants (dust, etc) and cleans motor before placing it on worktable.
 - ※ Lay the rubber plate on worktable and take care not to damage the component.



125LCR8TM02

- (2) Remove the connector (45) using 21 mm socket wrench.



125LCR8TM03

- (3) Remove plug (41) using 21 mm socket wrench.

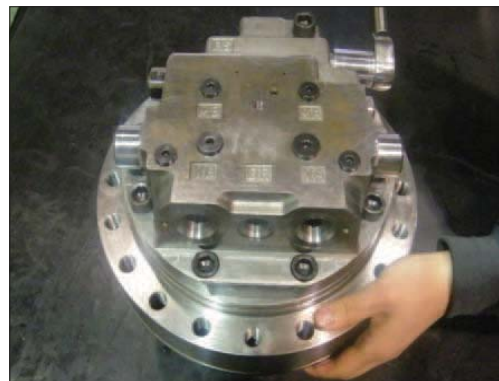

125LCR8TM04

- (4) Disassemble parallel pin (43) and spring (44).
 - ※ Do not lose spring.
 - ※ Do not mix spring with other springs.

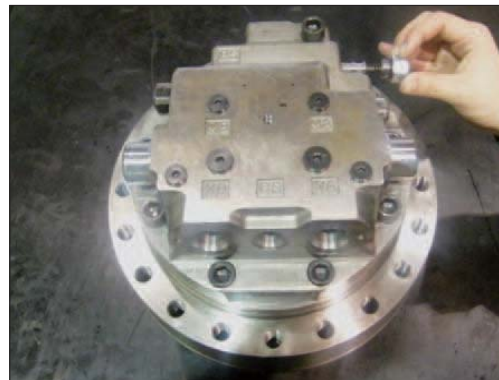

125LCR8TM05

(5) Remove spring seat (42) and spool (40).



125LCR8TM06

(6) Disassemble relief valve assembly (38) using 26 mm socket wrench. (2 sets)



125LCR8TM07

(7) Disassemble cover (32) using 41 mm socket wrench.

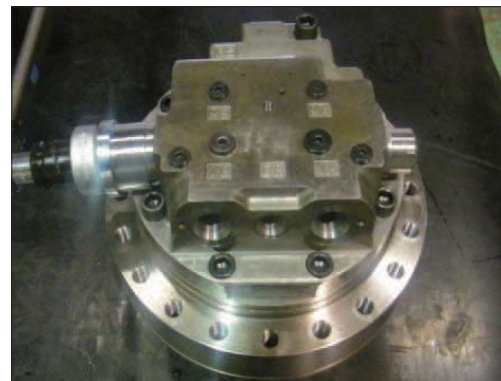

125LCR8TM08

(8) Disassemble spring seat (37) and spring (33). (2 sets)



125LCR8TM09

(9) Separate main spool assembly (31) from rear cover.

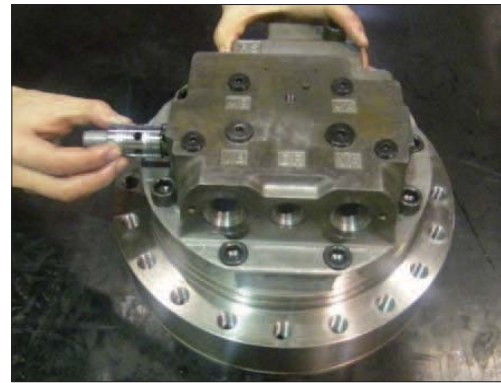

125LCR8TM10

(10) Unscrew socket bolt (47) (1EA), (48) (3EA), (49) (6EA) from rear cover.



125LCR8TM11

(11) Remove parallel pin (29).



125LCR8TM12

(12) From rear cover, disassemble valve plate (24) and O-ring (27).

※ Take care not to damage assembly surface of rear cover.



125LCR8TM13

(13) Disassemble restrictor (55, 56) (2EA).

- ※ Mark the number on restrictor and its hole to avoid confusing (55) and (56).



125LCR8TM14

(14) Remove plug (52).



125LCR8TM15

(15) Remove restrictor (34) and spring (35). (2 sets)

- ※ Do not confuse restrictor (34) and check valve (50).
- ※ Do not confuse spring (35) and spring (51).
- ※ Do not lose spring.
- ※ Do not mix spring with other springs.

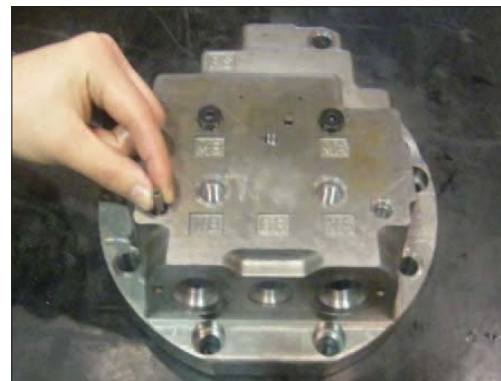

125LCR8TM16

(16) Remove plug (52) using 5 mm hexagon wrench.

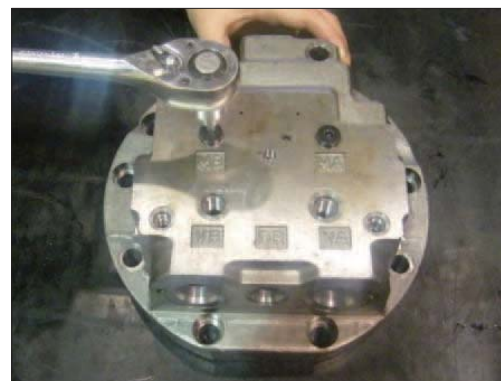

125LCR8TM17

(17) Remove check valve (50) and spring (51). (2 sets)

- ※ Do not confuse restrictor (34) and check valve (50).
- ※ Do not confuse spring (35) and spring (51).
- ※ Do not lose spring.
- ※ Do not mix spring with other springs.

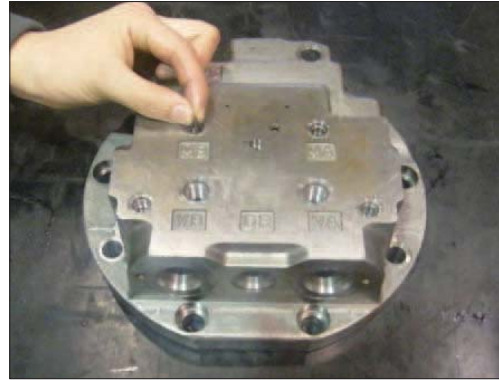

125LCR8TM18

(18) From parking piston, remove spring (26) (12ea).

- ※ Do not lose spring.
- ※ Do not mix spring with other springs.



125LCR8TM19

(19) Disassemble parking piston (19) using air gun or jig.



125LCR8TM20

(20) From parking piston, separate O-ring (22) and back-up ring (23).



125LCR8TM21

(21) From parking piston separate O-ring (20) and back-up ring (21).



125LCR8TM22

(22) Lay casing down horizontally and remove cylinder block assembly, friction plate (17) (3EA) and separator plate (18) (4EA).



125LCR8TM23

(23) Separate retainer plate (15) and piston assembly (16).

- ※ Take care not to damage sliding surface of each component.



125LCR8TM24

(24) Disassemble ball guide (14) and spring (13) (9EA).

- ※ Do not lose spring.
- ※ Do not mix spring with other springs.

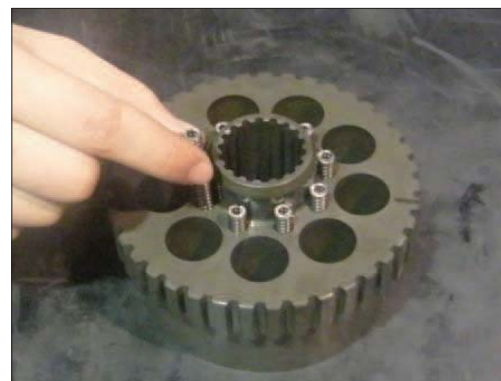

125LCR8TM25

(25) Disassemble swash plate (11) and steel ball (10).

※ Take care not to damage sliding surface.



125LCR8TM26

(26) Disassemble shaft (6) and ball bearing (7).

※ Do not remove ball bearing unless malfunction is detected, since it is mounted by shrink fit.



125LCR8TM27

(27) Disassemble 1, 2 speed piston (4) and steel ball (9) using air gun.



125LCR8TM28

(28) Disassemble piston seal (5).



125LCR8TM29

(29) Turn casing (1) upside down and remove oil seal (3) using jig.



125LCR8TM30

3) ASSEMBLY

※ Even though assembly is accomplished by reversing disassembly steps, be careful of the following.

- ① Repair the damaged part when disassembling and prepare parts for exchange in advance.
- ② All parts should be cleaned with cleaner, dried with compressed air.
- ③ Sliding surface, O-ring, bearing and oil seal should be lubricated with clean hydraulic oil, prior to final assembly.
- ④ Replacement of O-ring and oil seal with new parts is generally recommended.
- ⑤ Use a torque wrench to make sure that assembly fasteners are tightened to specified values shown table 1.
- ⑥ When assembling bolt, spread Loctite.

(1) Put casing (1) on the worktable.



125LCR8TM31

(2) After applying grease on the external diameter of oil seal (3), insert oil seal in casing.



125LCR8TM32

- (3) After applying grease on steel ball (10), insert steel ball in casing.



125LCR8TM33

- (4) After assembling piston seal (5) and steel ball (9) in 1, 2 speed piston (4), insert piston in hole of casing.
※ Check whether piston sticks in hole.
※ Use piston seal jig.



125LCR8TM34

- (5) Mount ball bearing (7) on shaft (6) by shrink fit. Insert shaft in casing.
※ Take care not to damage oil seal.



125LCR8TM35

- (6) Assemble swash plate (11) by matching its hole and steel ball.
※ Take care not to damage sliding surface.



125LCR8TM36

- (7) Assemble spring (13) (9ea) and ball guide (14) in cylinder block (12) in that order.



125LCR8TM37

- (8) Insert piston assembly (16) in retainer plate (15) and assemble them in cylinder block.
※ Spread hydraulic oil on piston assembly.
※ Take care not to damage each component.
※ Check cylinder block and piston assembly runs properly.



125LCR8TM38

- (9) Lay casing down horizontally and assemble cylinder block assembly by matching its spline with shaft.
※ Make sure swash plate stays in place.
※ Check the assembling status of cylinder block by pressing it.



125LCR8TM39

- (10) Assemble separator plate (18) (4EA) and friction plate (17) (3EA) alternately.

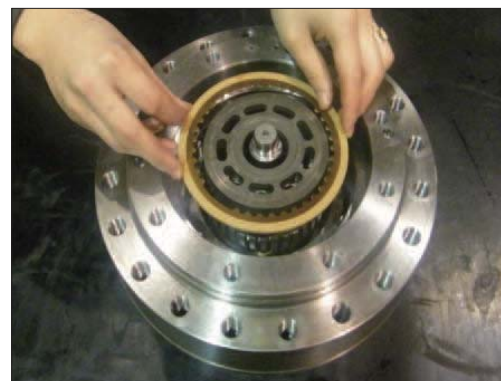

125LCR8TM40

(11) Insert back-up ring & O-ring in parking piston.



125LCR8TM41

(12) Align the pin hole of parking piston (19) with oil hole of casing, assemble them using jig.
※ Spread grease on O-ring and back-up ring.
※ Take care not to damage components.



125LCR8TM42

(13) Insert spring (26) (12EA) in parking piston.



125LCR8TM43

(14) Insert parallel pin (29) (2EA) in casing.



125LCR8TM44

(15) Assemble check valve (50) and spring (51) in order.

※ Do not confuse check valve (50) and restrictor (34).

※ Do not confuse spring (51) and spring (35)



125LCR8TM45

(16) Clamp plug (52) using 5 mm hexagon wrench.

※ Tightening torque : 1.5 kgf · m (10.9 lbf · ft)

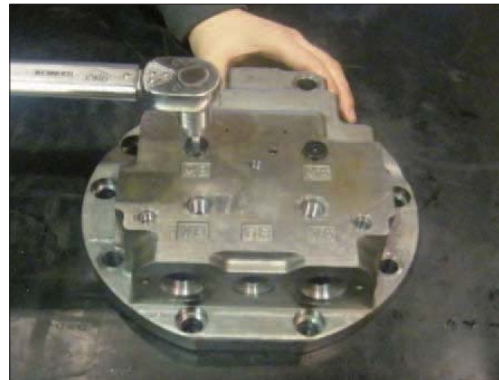

125LCR8TM46

(17) Assemble restrictor (34) and spring (35) in order.

※ Do not confuse check valve (50) and restrictor (34).

※ Do not confuse spring (51) and spring (35).



125LCR8TM47

(18) Clamp plug (52).

※ Tightening torque : 1.5 kgf · m (10.9 lbf · ft)



125LCR8TM48

(19) Clamp plug (54).

※ Tightening torque : 3 kgf · m (21.7 lbf · ft)



125LCR8TM49

(20) Assemble restrictor (55) and (56) in rear cover.

※ Check whether the restrictor is placed in exact hole.

※ Do not confuse (55) and (56).

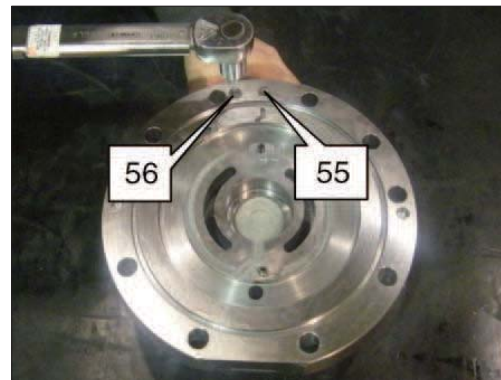

125LCR8TM50

(21) Assemble ball bearing (8) in rear cover using jig.



125LCR8TM51

(22) Insert spring pin (25) (2ea) and (28) in rear cover using jig.



125LCR8TM52

(23) After spreading grease sufficiently to the bottom side of valve plate (24), assemble valve plate in rear cover by matching its holes with pins.

- ※ Take care not to damage sliding surface.
- ※ Pay attention to the assembly direction.



125LCR8TM53

(24) Assemble O-ring (27) in rear cover.

- ※ Spread grease on O-ring.



125LCR8TM54

(25) Put rear cover upon casing, paying attention to the location of pin and hole. And tighten bolt (47), (48) and (49).

- ※ Tightening torque : 17.5 kgf · m (127 lbf · ft)
- ※ Make sure valve plate stays in place.
- ※ Check bolt position.



125LCR8TM55

(26) Assemble main spool assembly (31), spring seat (37) and spring (33) in rear cover.



125LCR8TM56

(27) Settle cover (32).

※ Tightening torque : 15 kgf · m (108 lbf · ft)

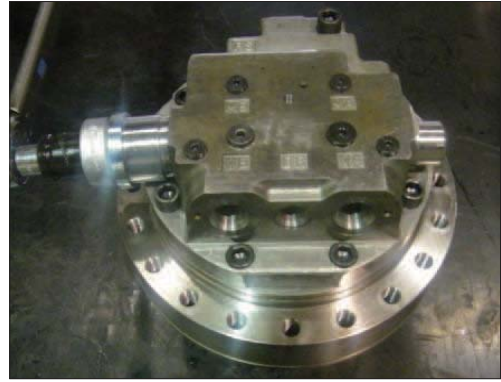

125LCR8TM57

(28) Insert relief valve (38) in rear cover.

※ Tightening torque : 15 kgf · m (108 lbf · ft)

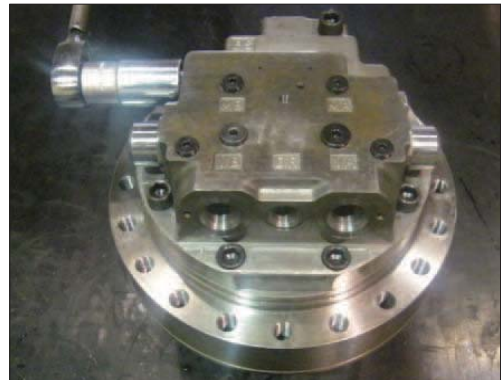

125LCR8TM58

(29) After clamping connector (45) to rear cover, assemble spool (40).

※ Tightening torque : 5 kgf · m (36 lbf · ft)

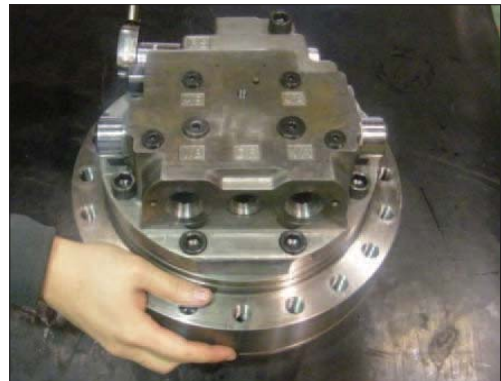

125LCR8TM59

(30) After inserting parallel pin (43), assemble seat-spring (42).

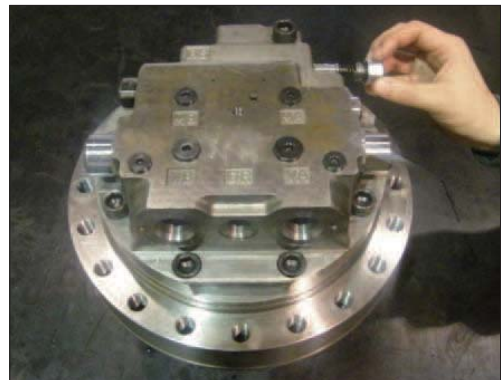

125LCR8TM60

(31) After assembling spring (44) in order, clamp plug (41).

※ Tightening torque : 5 kgf · m (36 lbf · ft)

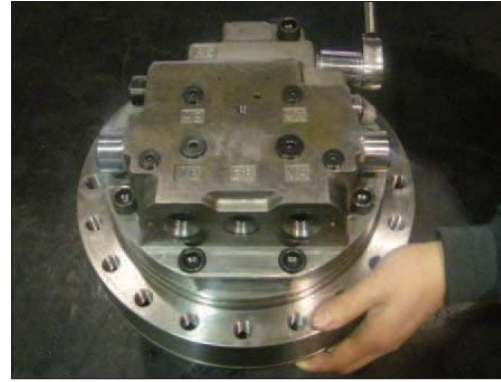

125LCR8TM61

3. TRAVEL REDUCTION GEAR DISASSEMBLY

1) While travel reduction gear is tilted to one side disassemble PF3/8 plug (24), remove gear oil and place motor side to the bench.



125LCR8TM70

2) Disassemble cover (22) by unscrewing the M10 bolts (23) (12 pcs).



125LCR8TM71

3) Disassemble sun gear No.1 (20), steel ball (21).



125LCR8TM72

4) Disassemble carrier No.1 assembly.



125LCR8TM73

Carrier No. 1 sub assy disassembly

- 5) Disassemble M8 bolt (18) from the carrier assembly. (3 pcs)



125LCR8TM74

- 6) Disassemble thrust plate No.1 (17) from the carrier assembly.



125LCR8TM75

- 7) Disassemble planetary gear No.1 (14).(3 pcs)



125LCR8TM76

- 8) Disassemble needle bearing (15).(3 pcs)
※ Do not disassemble inner race in the absence of abnormalities.



125LCR8TM77

9) Disassemble Sun gear No.2 (12).



125LCR8TM78

10) Disassemble M10 bolt (6).(4 pcs)

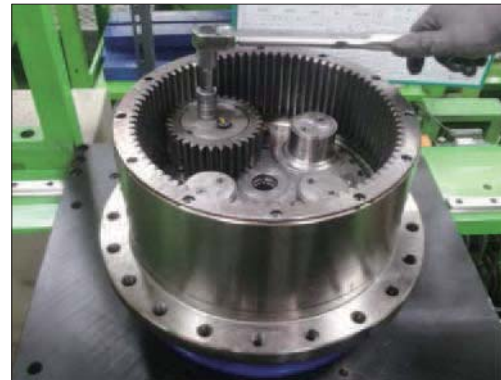

125LCR8TM79

11) Disassemble thrust washer No.2 (11).(4 pcs)



125LCR8TM80

12) Disassemble planetary gear No.2 (8).(4 pcs)



125LCR8TM81

13) Disassemble needle bearing No.2 (9).(4 pcs)



125LCR8TM82

14) Disassemble thrust plate No.2 (7).(4 pcs)

※ Do not disassemble inner race in the absence of abnormalities.



125LCR8TM83

15) Disassemble M10 bolt (6) and M8 screw bolt (19).



125LCR8TM84

16) Disassemble lock plate (5).



125LCR8TM85

17) Disassemble nut ring (4) by using the jig.



125LCR8TM86

18) Disassemble ring gear sun assembly from motor assembly.



125LCR8TM87

19) Disassemble folating seal assembly (3) from ring gear sun assembly and motor assembly.



125LCR8TM88

20) Disassemble bearing (2) (2ea) from ring gear assembly.

※ Do not disassemble bearing in the absence of abnormalities.

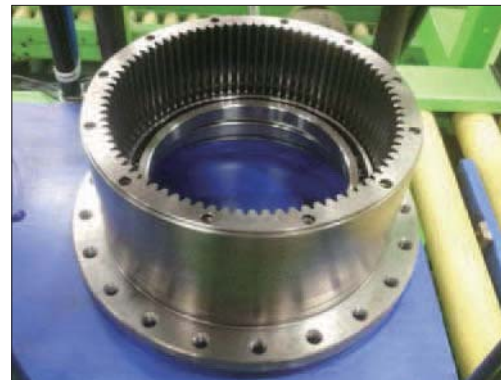

125LCR8TM89

4. TRAVEL REDUCTION GEAR ASSEMBLY

※ Even though assembly is accomplished by reversing disassembly steps, be careful of the following.

- ① Repair the damaged part when disassembling and prepare parts for exchange in advance.
- ② All parts should be cleaned with cleaner, dried with compressed air.
- ③ Sliding surface, O-ring, bearing and oil seal should be lubricated with clean hydraulic oil, prior to final assembly.
- ④ Replacement of O-ring and oil seal with new parts is generally recommended.
- ⑤ Use a torque wrench to make sure that assembly fasteners are tightened to specified values.
- ⑥ When assembling bolt, spread loctite.

1) Put carrier No.1 (13) on the jig, and shrink-fit inner race No.1 (16) to carrier pin.(3 places)

※ Do not tilt inner race to one side.

※ Match inner race and end of carrier pin.



125LCR8TM90

2) Assemble needle bearing No.1 (15).(3 pcs)



125LCR8TM91

3) Assemble planetary gear No.1 (14) of which groove is faced downward. (3 places)



125LCR8TM92

4) Assemble thrust plate No.1(17).



125LCR8TM93

5) After spreading loctite #242, assemble the M8 bolt (18).(3 pcs)

※ Tightening torque : $2.7 \pm 0.3 \text{ kgf} \cdot \text{m}$

※ After the assembly, instantly check the noise and interference by rotatong the gear.



125LCR8TM94

6) First, place bearing (2) on the ring gear (1), then put jig on it, then press it with press machine.



125LCR8TM95

- 7) After turning ring gear over, assemble bearing the same way.
※ Be care of nick and safety when turn ring gear over.



125LCR8TM96

- 8) Assemble folating seal assembly (3) by using the jig.
※ After assembling, wipe steel-lined section with alcohol.
※ Flatness deviation has to be less than 1 mm.



125LCR8TM97

- 9) Place folating seal assembly on the motor assembly then assemble it.
※ After assembling, wipe steel-lined section with alcohol.
※ Flatness deviation has to be less than 1 mm.



125LCR8TM98

- 10) After arriving safely ring gear sun assembly in the motor assembly, press it with press machine.
※ After press-fitting, clamp ring gear to fix it.
※ When using the press pay attention to bearing damage.



125LCR8TM99

14) Shrink fit the inner race No.2 (10).(4 pcs)



125LCR8TM104

15) Assemble thrust plate No.2 (7).(4 pcs)



125LCR8TM105

16) Assemble needle bearing No.2 (9).(4 pcs)



125LCR8TM106

17) Assemble planetary gear No.2 (8).(4 pcs)
※ Grooves of planetary gear will be facing up.



125LCR8TM107

18) Assemble thrust washer No.2 (11).(4 pcs)



125LCR8TM108

19) After spreading loctite #242, assemble the M10 bolt (6).(4 pcs)

※ Tightening torque : $5.5 \pm 0.6 \text{ kgf} \cdot \text{m}$
($39.8 \pm 4.3 \text{ lbf} \cdot \text{ft}$)



125LCR8TM109

20) Assemble sun gear No.2 (12).



125LCR8TM110

21) Assemble carrier No.1 assembly.



125LCR8TM111

22) Assemble sun gear No.1 (20).



125LCR8TM112

23) Place steel ball (21) on the sun gear No.1.



125LCR8TM113

24) Spread the loctite #515 on the cover (22) with reference to the right detail view.

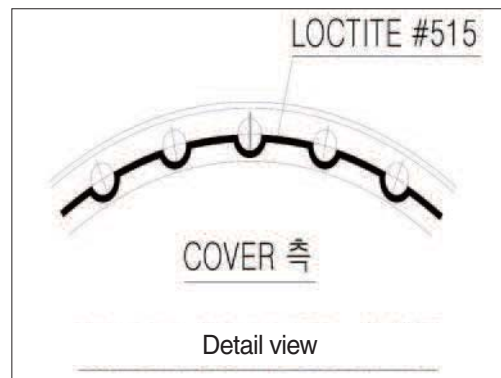

125LCR8TM114

25) Place cover (22) to fit the bolt holes.



125LCR8TM115

26) After spreading loctite #242, assemble the M10 bolt (23).(12 pcs)

※ Tightening torque : 6.3 ± 0.7 kgf · m
(45.6 ± 5.1 lbf · ft)



125LCR8TM116

27) Inject the 2.5 ± 0.3 liter gear oil to PF3/8 tap section.

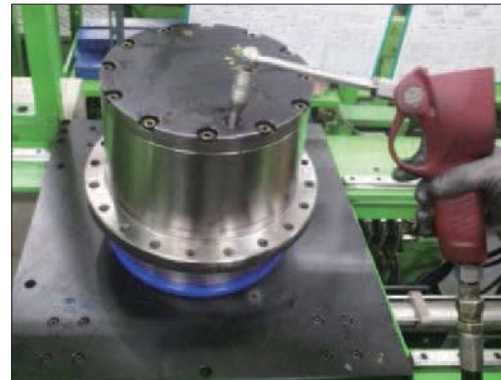

125LCR8TM117

28) After assembling the O-ring (25) to the plug (24), assemble it to the cover.(3 pcs)

※ Tightening torque : 5 ± 0.5 kgf · m
(36.2 ± 3.6 lbf · ft)



125LCR8TM118

GROUP 7 RCV LEVER

1. REMOVAL AND INSTALL

1) REMOVAL

- (1) Lower the work equipment to the ground and stop the engine.
- (2) Operate the control levers and pedals several times to release the remaining pressure in the hydraulic piping.
- (3) Loosen the breather slowly to release the pressure inside the hydraulic tank.

▲ Escaping fluid under pressure can penetrate the skin causing serious injury.

- (4) Loosen the socket bolt (1).
 - (5) Remove the cover of the console box.
 - (6) Disconnect pilot line hoses (3).
 - (7) Remove the pilot valve assembly (2).
- ※ When removing the pilot valve assembly, check that all the hoses have been disconnected.

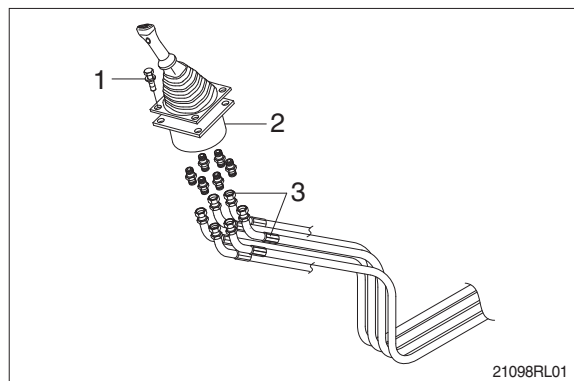

2) INSTALL

- (1) Carry out installation in the reverse order to removal.
- (2) Confirm the hydraulic oil level and check the hydraulic oil leak or not.

2. DISASSEMBLY AND ASSEMBLY

1) STRUCTURE

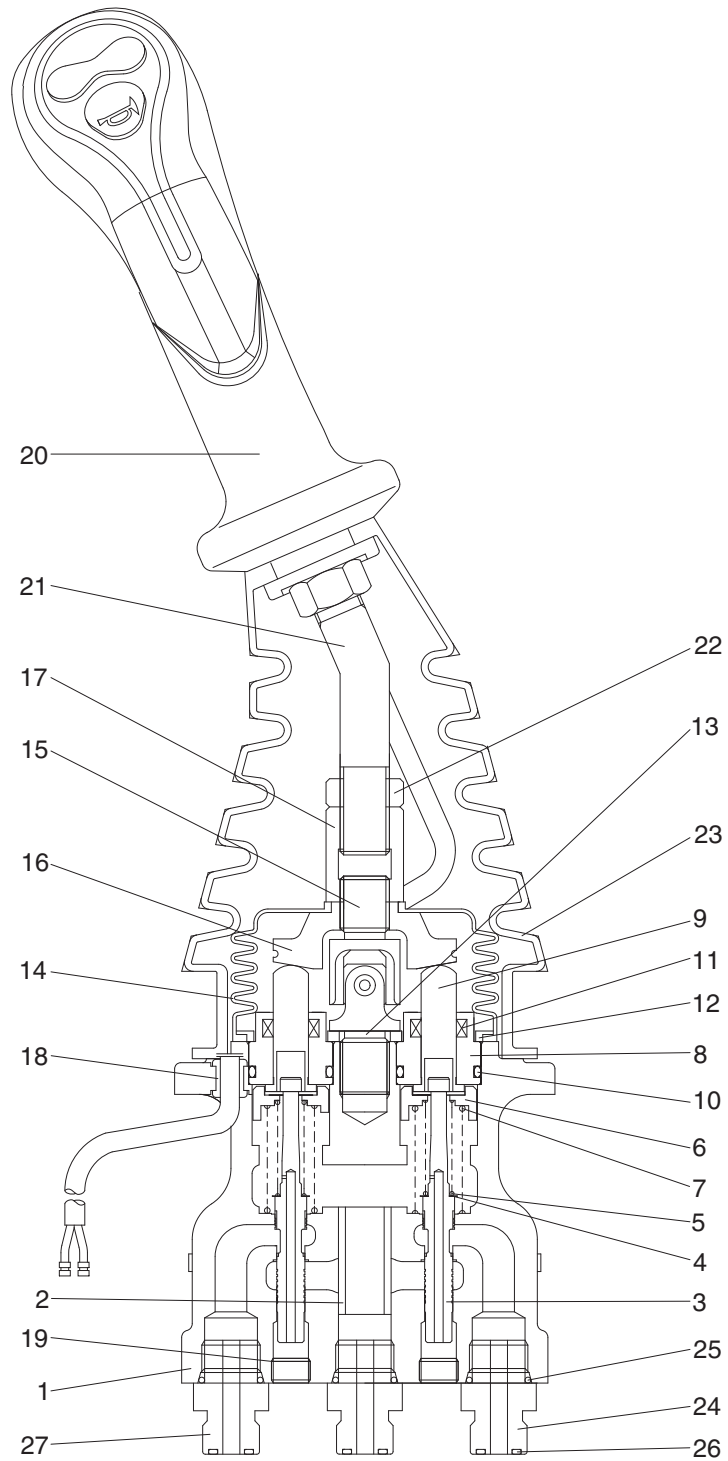

300L2RL06

1	Case	8	Plug	15	Joint assembly	22	Nut
2	Bushing	9	Push rod	16	Swash plate	23	Boot
3	Spool	10	O-ring	17	Adjusting nut	24	Last guard filter
4	Shim	11	Rod seal	18	Bushing	25	O-ring
5	Spring	12	Plate	19	Plug	26	O-ring
6	Spring seat	13	Spacer	20	Handle assembly	27	Connector
7	Spring	14	Boot	21	Handle bar		

2) TOOLS AND TIGHTENING TORQUE

(1) Tools

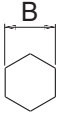
Tool name	Remark	
Allen wrench	6	
Spanne	22	
	27	
(+) Driver	Length 150	
(-) Driver	Width 4~5	
Torque wrench	Capable of tightening with the specified torques	

(2) Tightening torque

Part name	Item	Size	Torque	
			kgf · m	lbf · ft
Joint	15	M14	3.5	25.3
Swash plate	16	M14	5.0±0.35	36.2±2.5
Adjusting nut	17	M14	5.0±0.35	36.2±2.5
Lock nut	22	M14	5.0±0.35	36.2±2.5

3) DISASSEMBLY

※ Procedures are based on the type M1.

- (1) Clean pilot valve with kerosene.
 - ※ Put blind plugs into all ports
- (2) Fix pilot valve in a vise with copper (or lead) sheets.
- (3) Remove end of boot (23) from case (1) and take it out upwards.

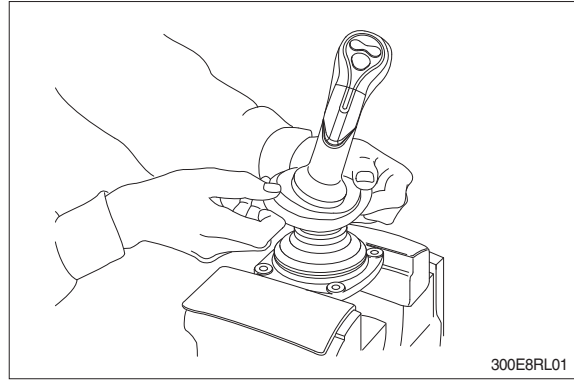

※ For valve with switch, remove cord also through hole of casing.

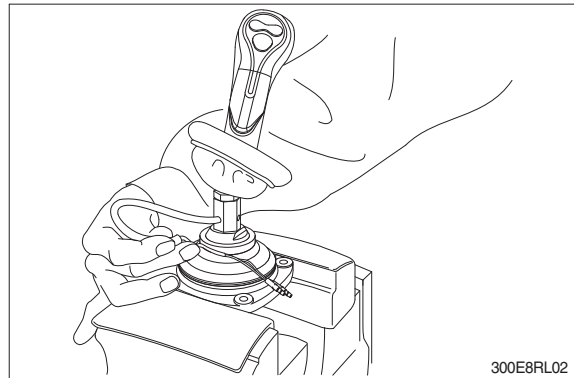

- (4) Loosen lock nut (22) and adjusting nut (17) with spanners on them respectively, and take out handle section as one body.

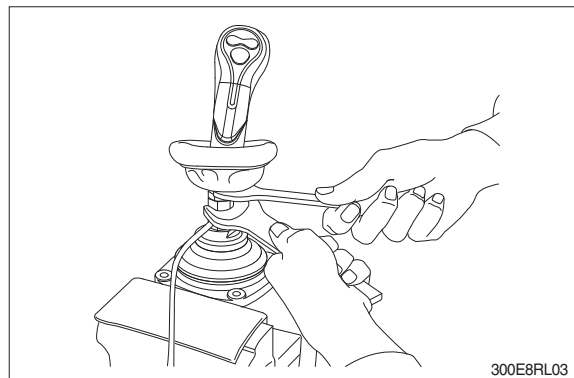

- (5) Remove the boot (14).

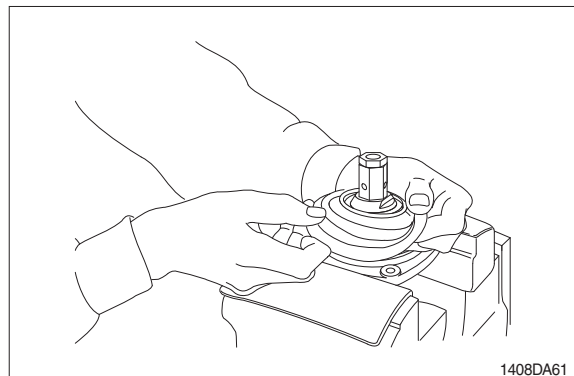

- (6) Loosen adjusting nut (17) and swash plate (16) with spanners on them respectively, and remove them.

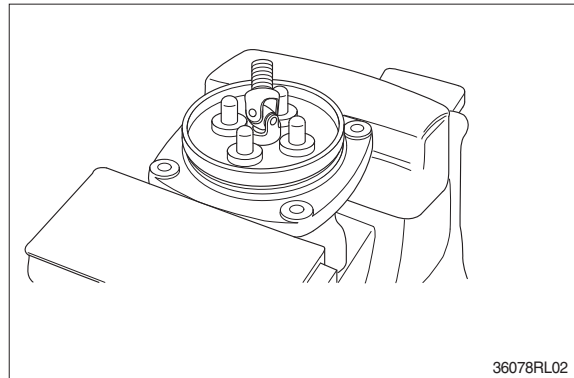
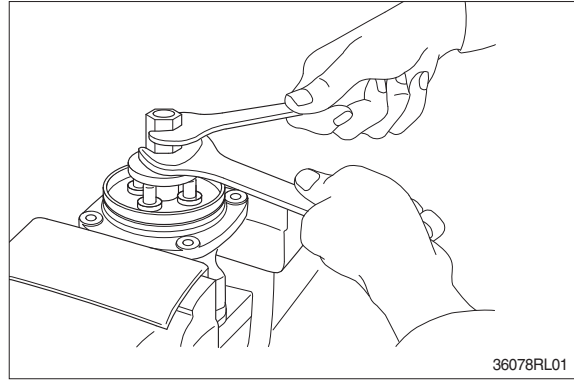

- (7) Turn joint anticlockwise to loosen it, utilizing jig (Special tool).

- ※ When return spring (7) is strong in force, plate (12), plug (8) and push rod (9) will come up on loosening joint. Pay attention to this.

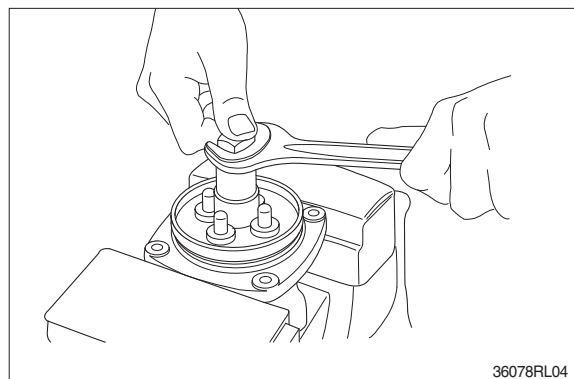
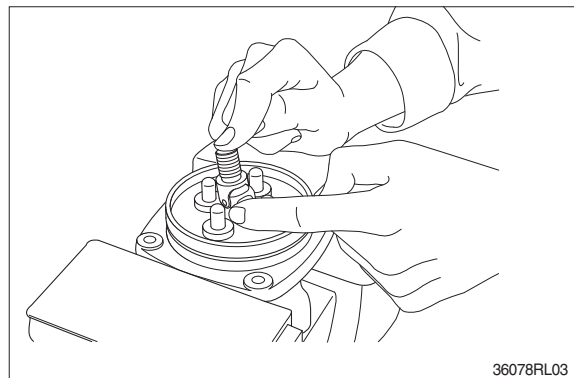

(8) Remove plate (12).

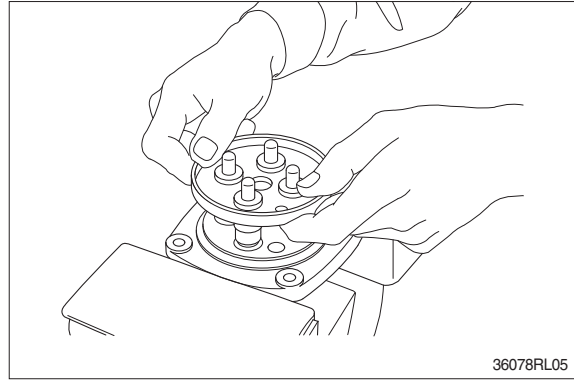

(9) When return spring (7) is weak in force, plug (8) stays in casing because of sliding resistance of O-ring.

- ※ Take it out with minus screwdriver. Take it out, utilizing external periphery groove of plug and paying attention not to damage it by partial loading.
- ※ During taking out, plug may jump up due to return spring (7) force. Pay attention to this.

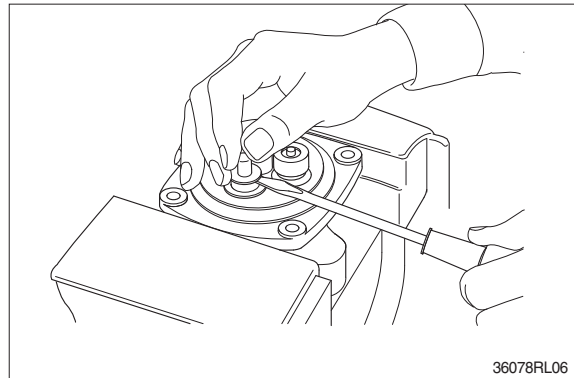

(10) Remove reducing valve subassembly and return spring (7) out of casing.

- ※ Record relative position of reducing valve subassembly and return springs.

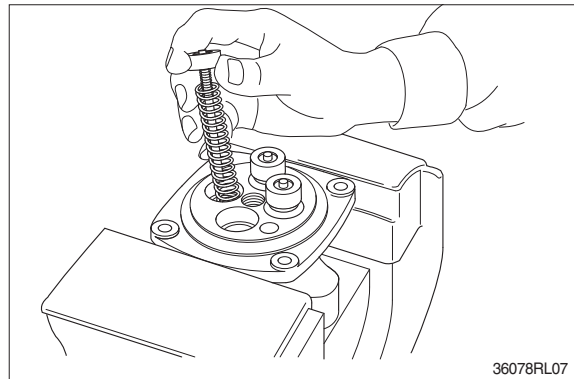

(11) Separate spool (3), spring seat (6), spring (5) and shim (4) individually.

- ※ Pay attention not to damage spool surface.
- ※ Record original position of spring seat (6).
- ※ Until being assembled, they should be handled as one subassembly group.

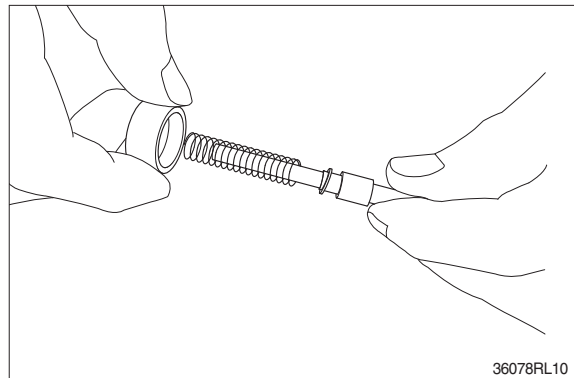

(12) Take push rod (9) out of plug (8).

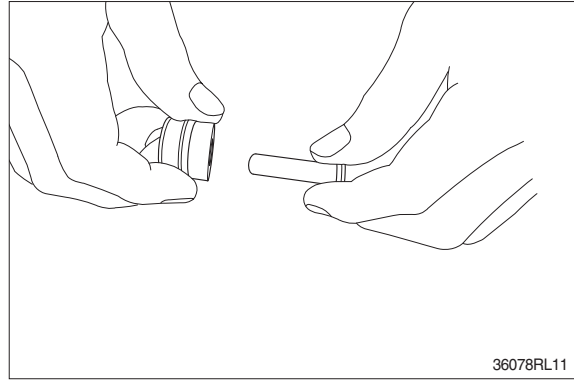

(13) Remove O-ring (10) and seal (11) from plug (8).
Use small minus screwdriver or so on to remove this seal.

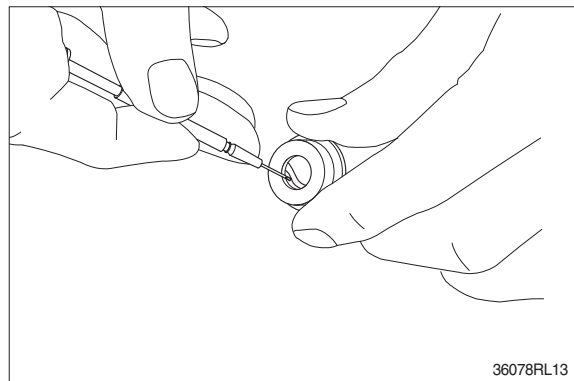
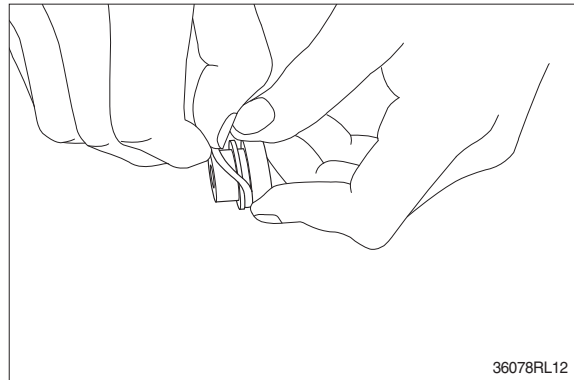

(14) Remove lock nut (22) and then boot (23).

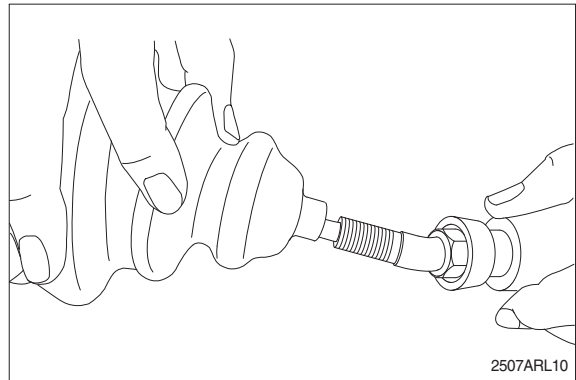
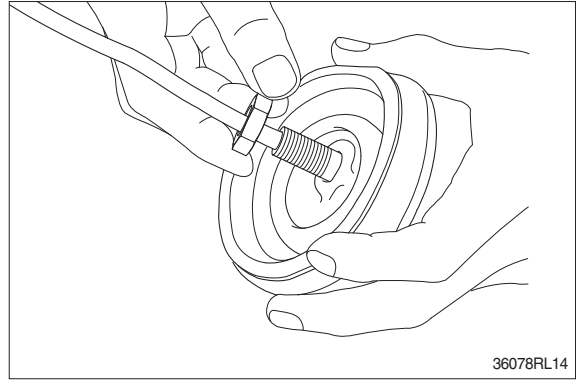

(15) Cleaning of parts

- ① Put all parts in rough cleaning vessel filled with kerosene and clean them (rough cleaning).
 - ※ If dirty part is cleaned with kerosene just after putting it in vessel, it may be damaged. Leave it in kerosene for a while to loosen dust and dirty oil.
 - ※ If this kerosene is polluted, parts will be damaged and functions of reassembled valve will be degraded.
Therefore, control cleanliness of kerosene fully.
- ② Put parts in final cleaning vessel filled with kerosene, turning it slowly to clean them even to their insides (finish cleaning).
 - ※ Do not dry parts with compressed air, since they will be damaged and/or rusted by dust and moisture in air.

(16) Rust prevention of parts

- Apply rust-preventives to all parts.
- ※ If left as they are after being cleaned, they will be rusted and will not display their functions fully after being reassembled.

4) ASSEMBLY

- (1) Put shim (4), springs (5) and spring seat (6) onto spool (3) in this order.

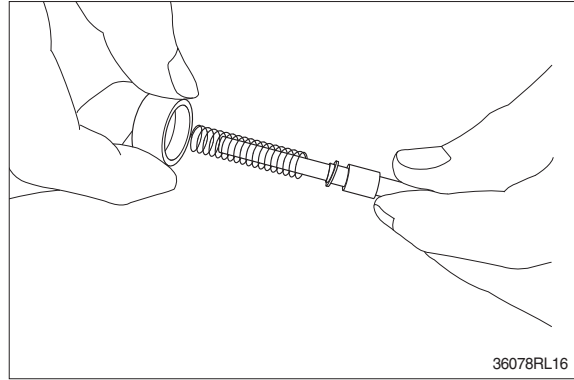

- (2) Assemble spring (7) into casing (1).
Assemble reducing valve subassembly into casing.
※ Assemble them to their original positions.

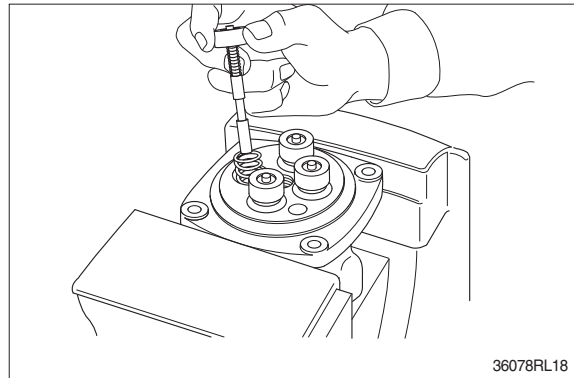

- (3) Assemble O-ring (10) onto plug (8).

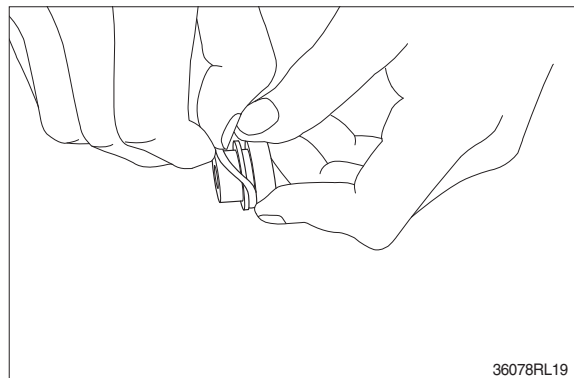

- (4) Assemble seal (11) to plug (8).
※ Assemble seal in such lip direction as shown below.

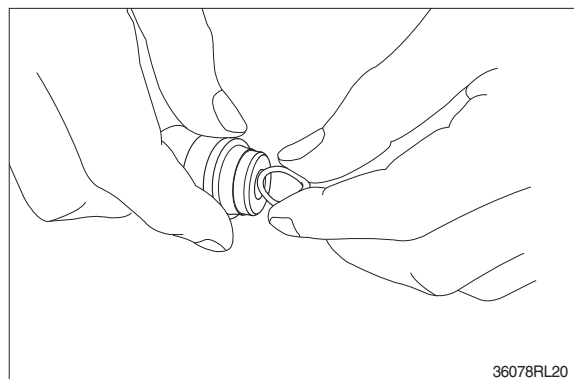

- (5) Assemble push rod (9) to plug (8).
※ Apply working oil on push-rod surface.

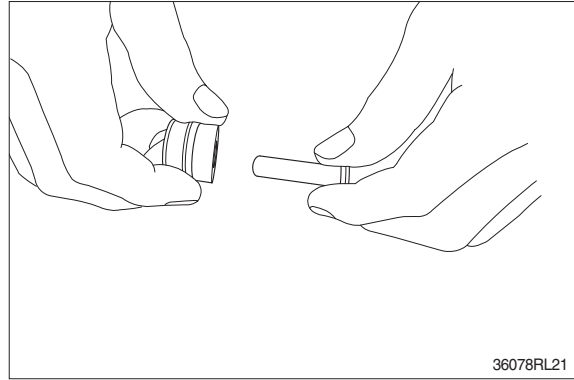

- (6) Assemble plug subassembly to casing.
※ When return spring is weak in force, subassembly stops due to resistance of O-ring.

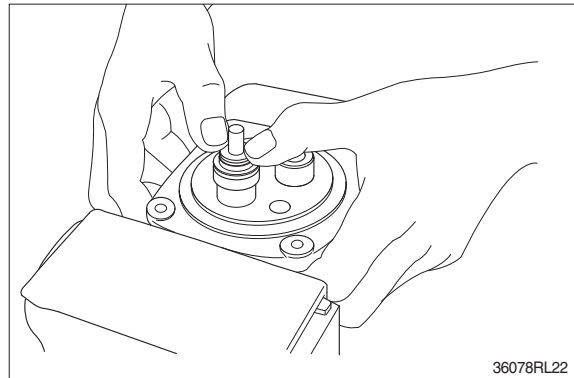

- (7) When return spring is strong in force, assemble 4 sets at the same time, utilizing plate (12), and tighten joint (15) temporarily.

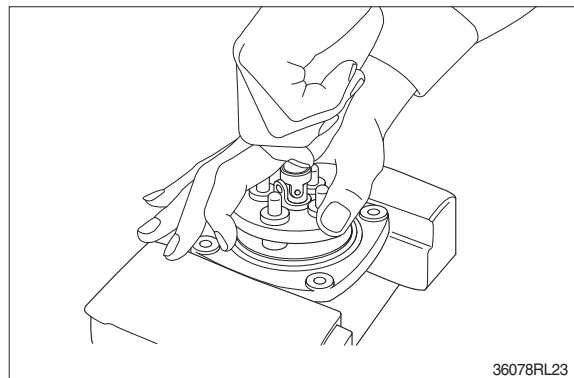

- (8) Fit plate (12).

- (9) Tighten joint (15) with the specified torque to casing, utilizing jig.

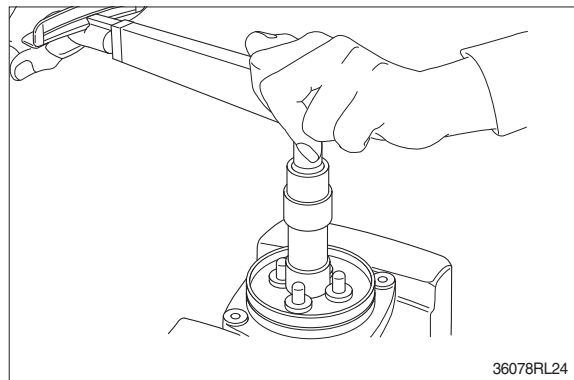

(10) Assemble swash plate (16) to joint (15).

- ※ Screw it to position that it contacts with 4 push rods evenly.
- ※ Do not screw it over.

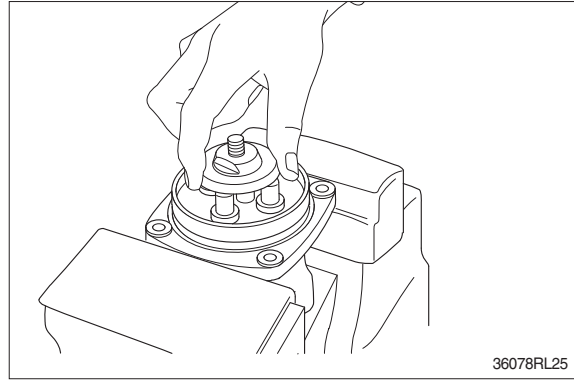

(11) Assemble adjusting nut (17), apply spanner to width across flat of plate (16) to fix it, and tighten adjusting nut to the specified torque.

- ※ During tightening, do not change position of disk.

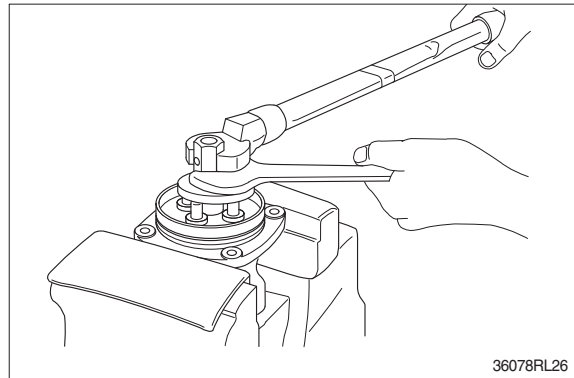

(12) Fit boot (14) to plate.

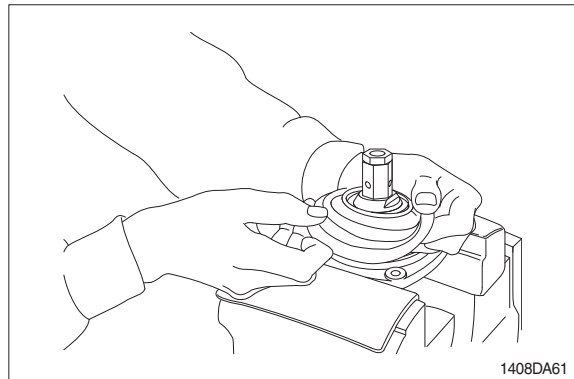

(13) Fit boot (23) and lock nut (22), and handle subassembly is assembled completely.

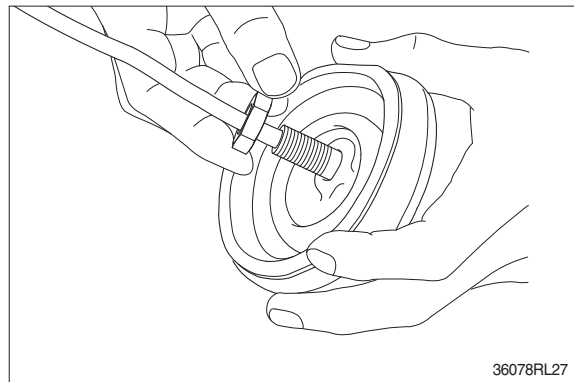
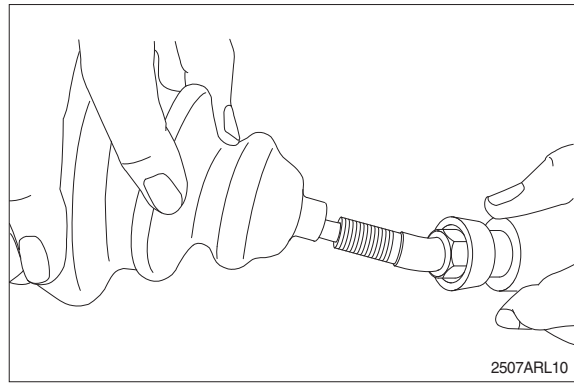

(14) Pull out cord and tube through adjusting nut hole provided in direction 60° to 120° from casing hole.

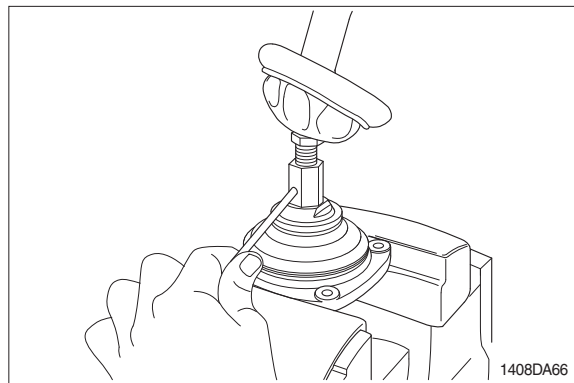

(15) Assemble bushing (18) to plate and pass cord and tube through it.
※ Provide margin necessary to operation.

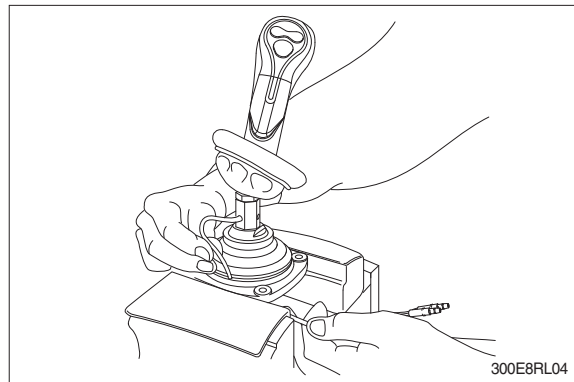

(16) Determine handle direction, tighten lock nut (22) to specified torque to fix handle.

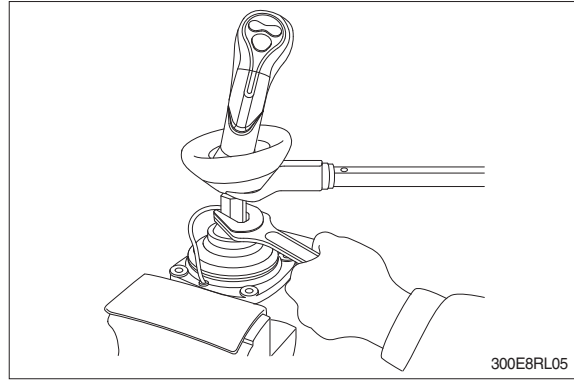

(17) Apply grease to rotating section of joint and contacting faces of disk and push rod.

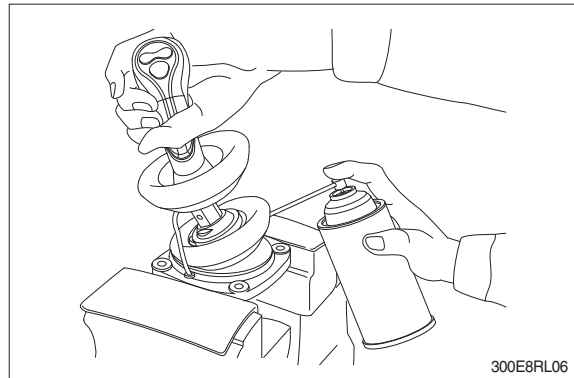

(18) Assemble lower end of bellows to casing.

(19) Inject volatile rust-preventives through all ports and then put blind plugs in ports.

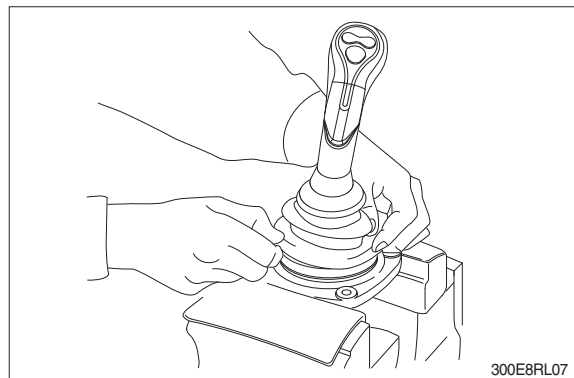

GROUP 8 TURNING JOINT

1. REMOVAL AND INSTALL

1) REMOVAL

- (1) Lower the work equipment to the ground and stop the engine.
- (2) Operate the control levers and pedals several times to release the remaining pressure in the hydraulic piping.
- (3) Loosen the breather slowly to release the pressure inside the hydraulic tank.

▲ **Escaping fluid under pressure can penetrate the skin causing serious injury.**

※ When pipes and hoses are disconnected, the oil inside the piping will flow out, so catch it in oil pan.

- (4) Disconnect all hoses.
- (5) Sling the turning joint assembly (1) and remove the mounting bolt (2).
 - Weight : 50 kg (110 lb)
 - Tightening torque : $12.3 \pm 1.3 \text{ kgf} \cdot \text{m}$
($88.9 \pm 9.4 \text{ lbf} \cdot \text{ft}$)
- (6) Remove the turning joint assembly.

※ When removing the turning joint, check that all the hoses have been disconnected.

2) INSTALL

- (1) Carry out installation in the reverse order to removal.
 - ※ Take care of turning joint direction.
 - ※ Assemble hoses to their original positions.
 - ※ Confirm the hydraulic oil level and check the hydraulic oil leak or not.

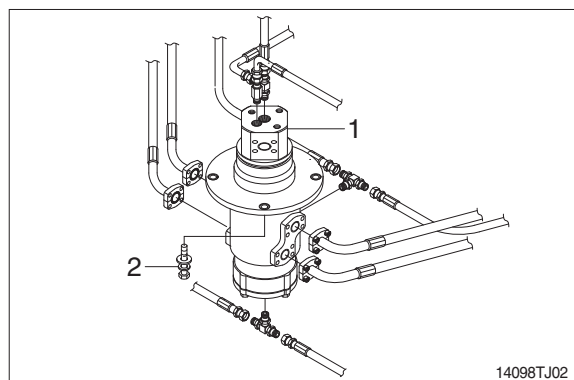
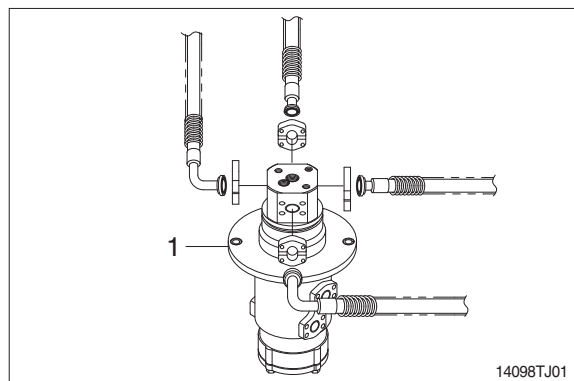

2. DISASSEMBLY AND ASSEMBLY

1) STRUCTURE

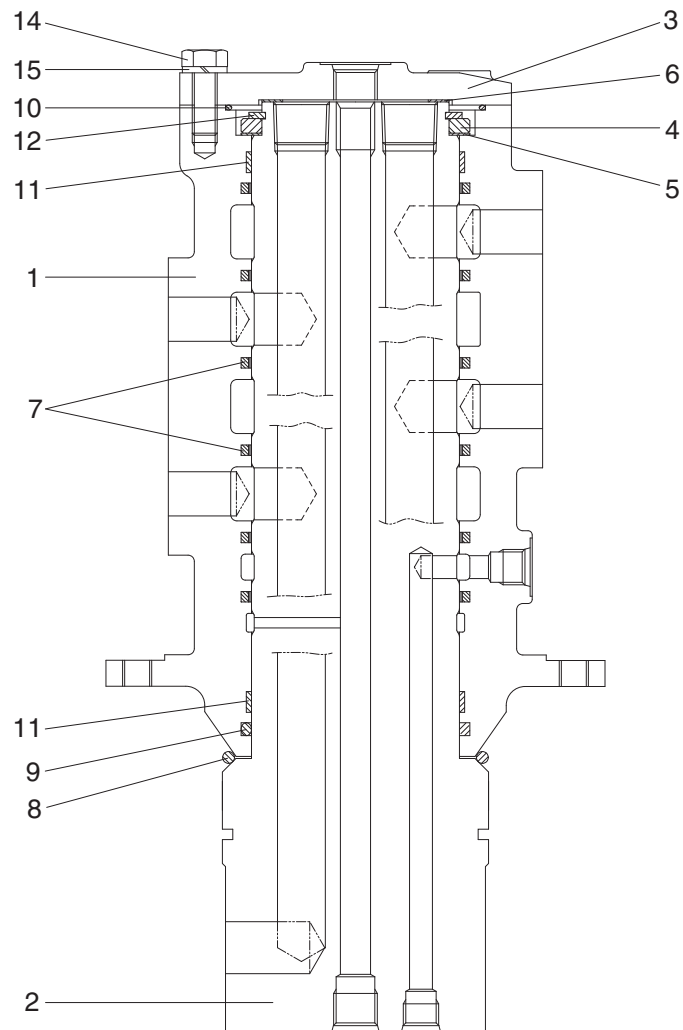

14098TJ03

- | | | | | | |
|---|--------|----|--------------|----|---------------|
| 1 | Hub | 6 | Shim | 11 | Wear ring |
| 2 | Shaft | 7 | Slipper seal | 12 | Retainer ring |
| 3 | Cover | 8 | O-ring | 13 | Plug |
| 4 | Spacer | 9 | O-ring | 14 | Hexagon bolt |
| 5 | Shim | 10 | O-ring | 15 | Spring washer |

2) DISASSEMBLY

※ Before the disassembly, clean the turning joint.

- (1) Remove bolts (14), washer (15) and cover (3).

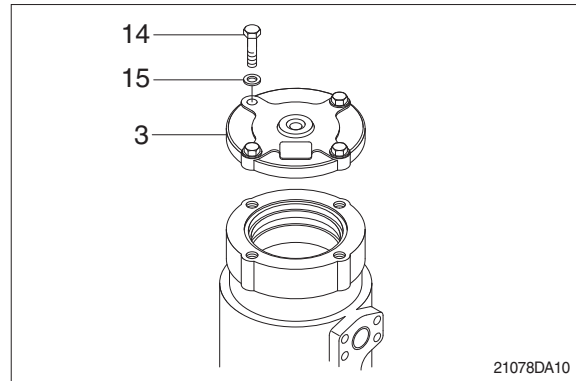

- (2) Remove shim (6) and O-ring (10).

- (3) Remove retainer ring (12), spacer (4) and shim (5).

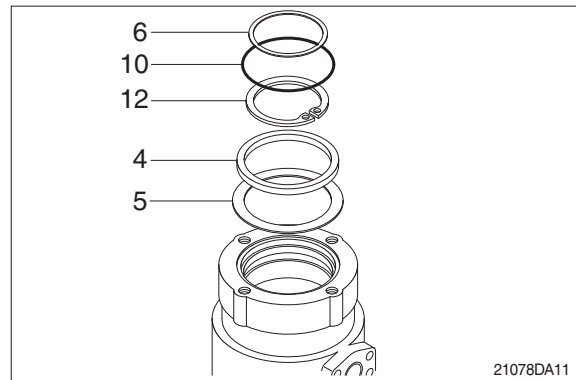

- (4) Place hub (1) on a V-block and by using a wood buffer at the shaft end, hit out shaft (2) to about 1/2 from the body with a hammer.

※ Take care not to damage the shaft (2) when remove hub (1) or rest it sideways.
※ Put a fitting mark on hub (1) and shaft (2).

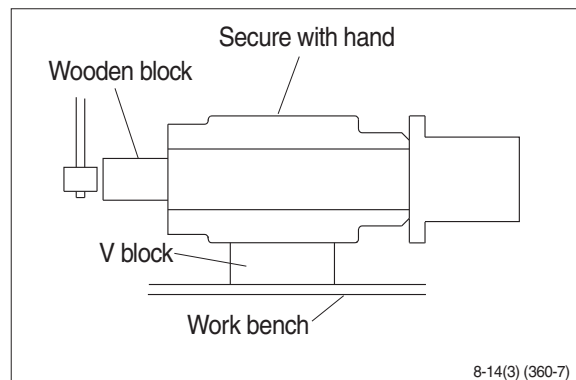

- (5) Remove six slipper seals (7) and O-ring (9), two wear ring (11) from hub (1).

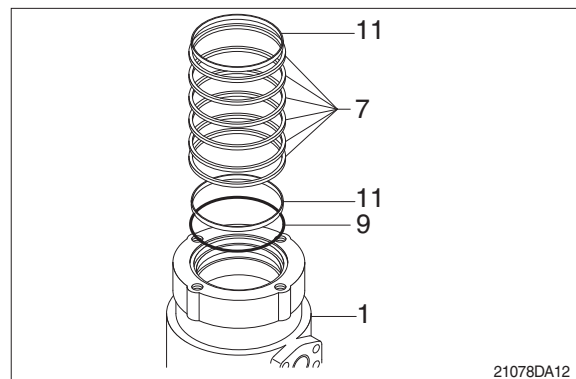

3) ASSEMBLY

- ※ Clean all parts.
- ※ As a general rule, replace oil seals and O-ring.
- ※ Coat the sliding surfaces of all parts with engine oil or grease before installing.

(1) Fix seven slipper seal (7) and O-ring (9), two wear ring (11) to hub (1).

(2) Fit O-ring (8) to shaft (2).

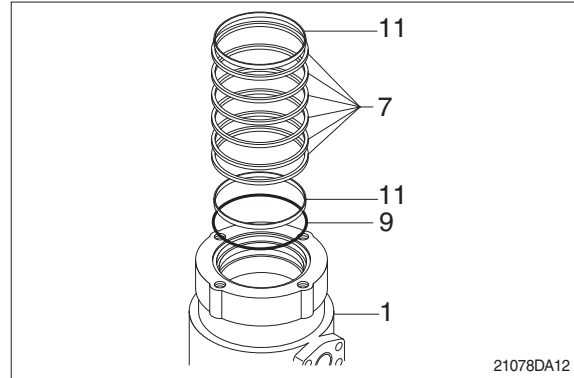

(3) Set shaft (2) on block, tap hub (1) with a plastic hammer to install.

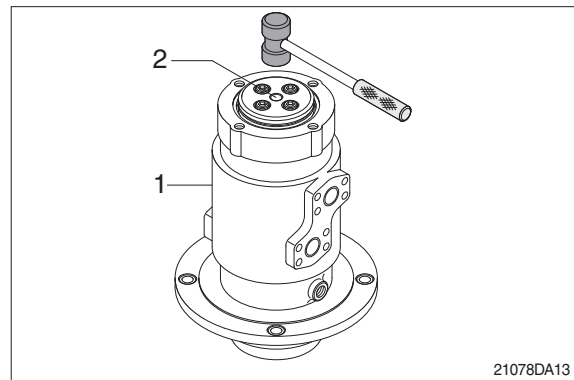

(4) Fit shim (5), spacer (4) and retainer ring (12) to shaft (2).

(5) Fit O-ring (10) to hub (1).

(6) Fit shim (6) to shaft (2).

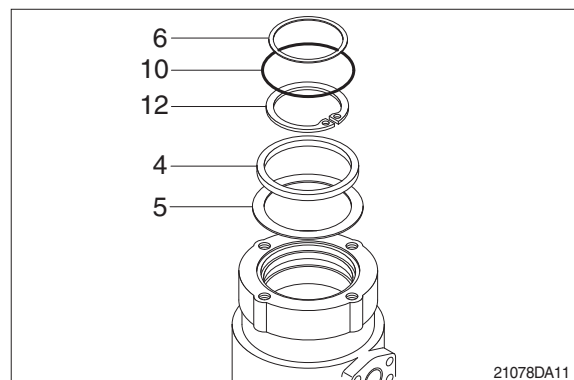

- (7) Install cover (3) to body (1) and tighten bolts (14).
- Torque : 10~12.5 kgf · m
(72.3~90.4 lbf · ft)

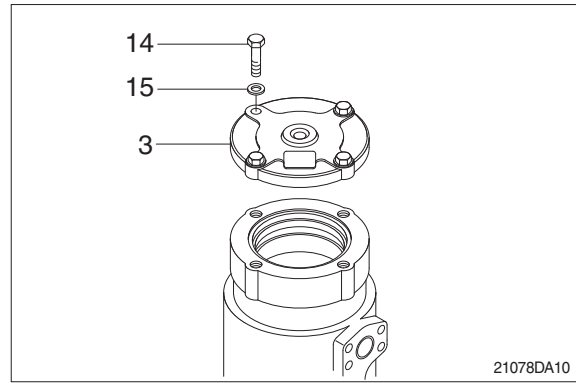

GROUP 9 BOOM, ARM, BUCKET AND DOZER CYLINDERS

1. REMOVAL AND INSTALL

1) BUCKET CYLINDER

(1) Removal

- ※ Expand the arm and bucket fully, lower the work equipment to the ground and stop the engine.
- ※ Operate the control levers and pedals several times to release the remaining pressure in the hydraulic piping.
- ※ Loosen the breather slowly to release the pressure inside the hydraulic tank.

▲ Escaping fluid under pressure can penetrate the skin causing serious injury.

- ※ Fit blind plugs in the hoses after disconnecting them, to prevent dirt or dust from entering.

① Set block between bucket cylinder and arm.



13031GE18

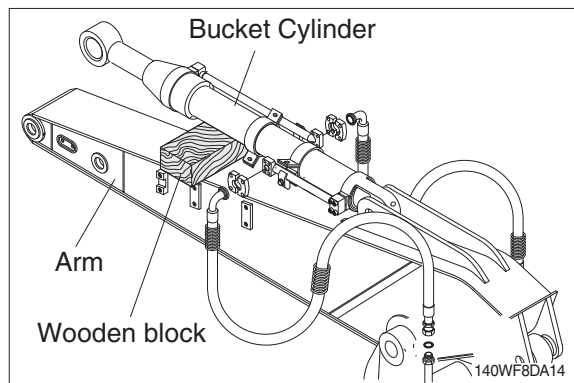

② Remove bolt (2), nut (3) and pull out pin (1).

- ※ Tie the rod with wire to prevent it from coming out.

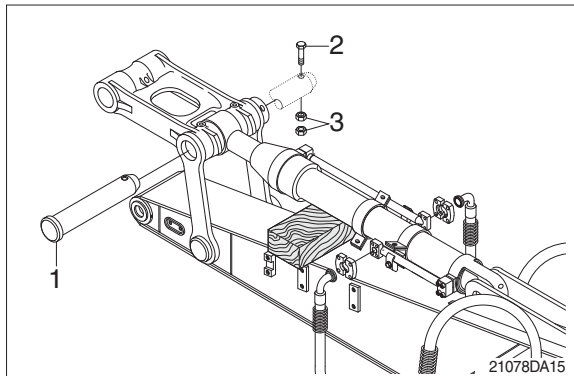

③ Disconnect bucket cylinder hoses (4) and put plugs (5) on cylinder pipe.

④ Disconnect greasing piping (6).

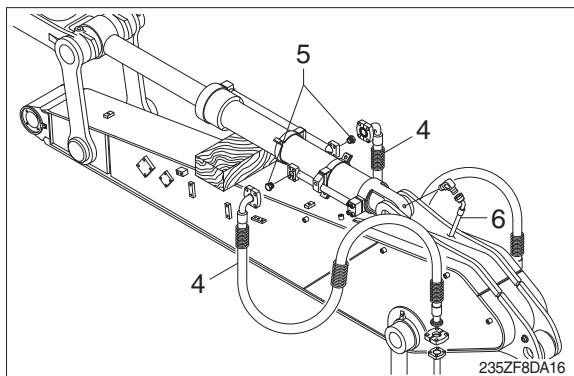

- ⑤ Sling bucket cylinder assembly (8) and remove bolt (6) then pull out pin (5).
- ⑥ Remove bucket cylinder assembly (8).
 - Weight : 100 kg (220 lb)

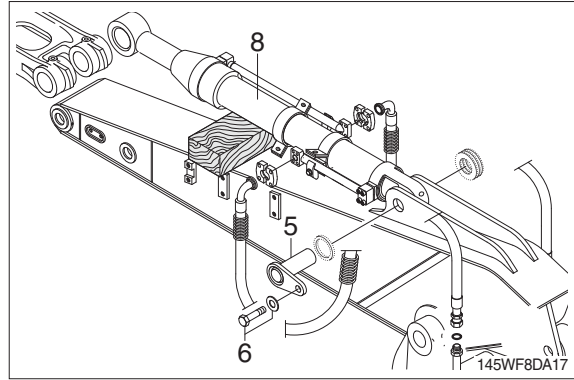

(2) Install

- ① Carry out installation in the reverse order to removal.
- ▲ When aligning the mounting position of the pin, do not insert your fingers in the pin hole.**
- ※ Bleed the air from the bucket cylinder.
 - ※ Confirm the hydraulic oil level and check the hydraulic oil leak or not.

2) ARM CYLINDER

(1) Removal

- ※ Expand the arm and bucket fully, lower the work equipment to the ground and stop the engine.
- ※ Operate the control levers and pedals several times to release the remaining pressure in the hydraulic piping.
- ※ Loosen the breather slowly to release the pressure inside the hydraulic tank.

▲ Escaping fluid under pressure can penetrate the skin causing serious injury. Fit blind plugs in the hoses after disconnecting them, to prevent dirt or dust from entering.

- ① Set block between arm cylinder and boom.

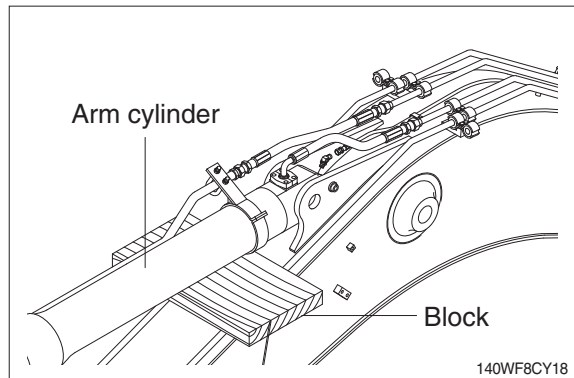

- ② Remove bolt (2) and pull out pin (1).
 - ③ Disconnect greasing piping (4) of arm cylinder rod.
- ※ Tie the rod with wire to prevent it from coming out.

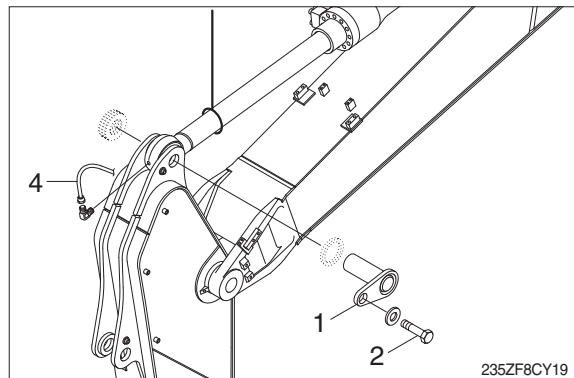

- ④ Disconnect arm cylinder hoses (5) and put plugs on cylinder pipe.
- ⑤ Disconnect greasing pipings (6).

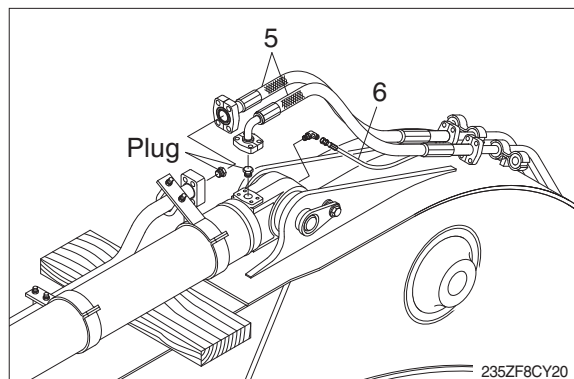

- ⑥ Sling arm cylinder assembly (9) and remove bolt (8) then pull out pin (7).
- ⑦ Remove arm cylinder assembly (9).
 - Weight : 160 kg (350 lb)

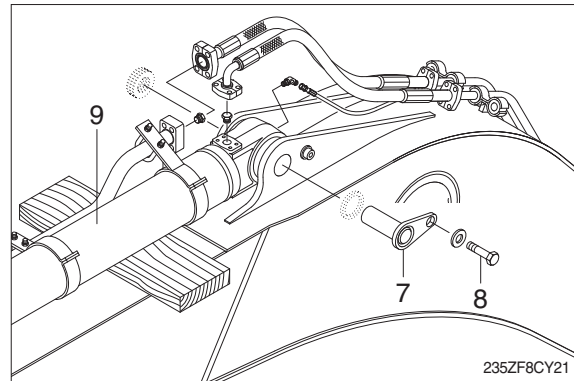

(2) Install

- ① Carry out installation in the reverse order to removal.
- ▲ When aligning the mounting position of the pin, do not insert your fingers in the pin hole.**
- ※ Bleed the air from the arm cylinder.
 - ※ Confirm the hydraulic oil level and check the hydraulic oil leak or not.

3) BOOM CYLINDER

(1) Removal

- ※ Expand the arm and bucket fully, lower the work equipment to the ground and stop the engine.
- ※ Operate the control levers and pedals several times to release the remaining pressure in the hydraulic piping.
- ※ Loosen the breather slowly to release the pressure inside the hydraulic tank.

▲ Escaping fluid under pressure can penetrate the skin causing serious injury.

- ※ Fit blind plugs in the hoses after disconnecting them, to prevent dirt or dust from entering.
- ① Disconnect greasing hoses (1).
 - ② Sling boom cylinder assembly.

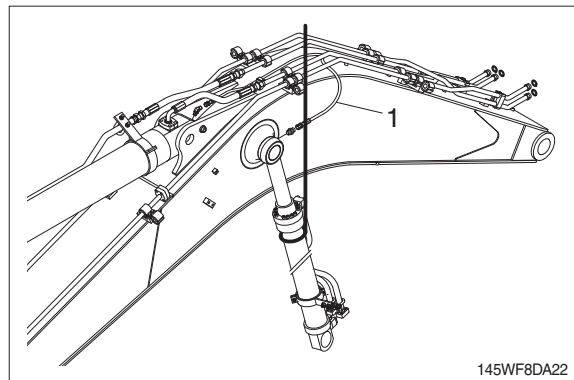

- ③ Remove bolt (4), stopper (5) and pull out pin (2).
- ※ Tie the rod with wire to prevent it from coming out.

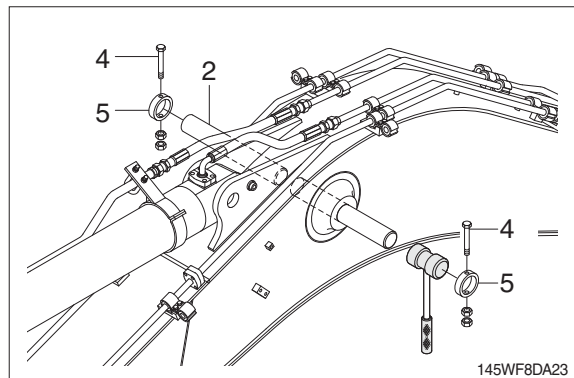

- ④ Lower the boom cylinder assembly (6) on a stand.

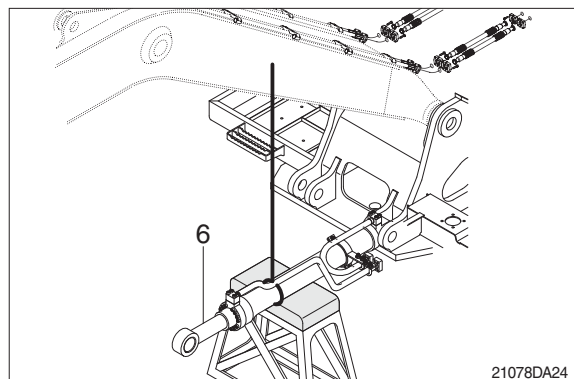

- ⑤ Disconnect boom cylinder hoses (7) and put plugs on cylinder pipe.

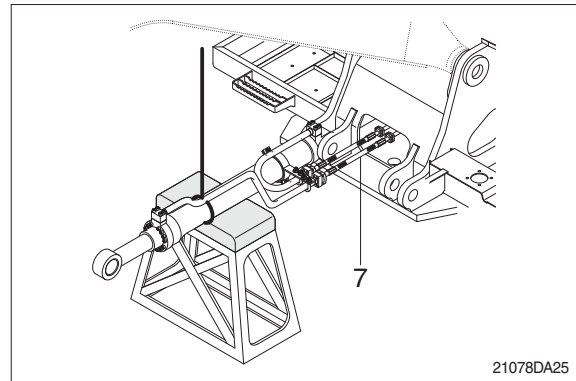

- ⑥ Remove bolt (9) and pull out pin (8).
⑦ Remove boom cylinder assembly (6).
· Weight : 130 kg (285 lb)

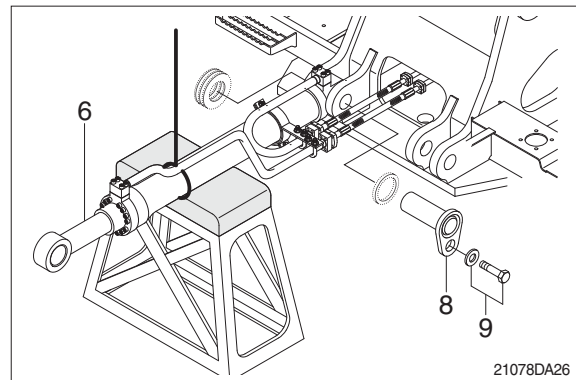

(2) Install

- ① Carry out installation in the reverse order to removal.
- ▲ When aligning the mounting position of the pin, do not insert your fingers in the pin hole.**
- ※ Bleed the air from the boom cylinder.
 - ※ Confirmed the hydraulic oil level and check the hydraulic oil leak or not.

2. DISASSEMBLY AND ASSEMBLY

1) STRUCTURE

(1) Bucket cylinder

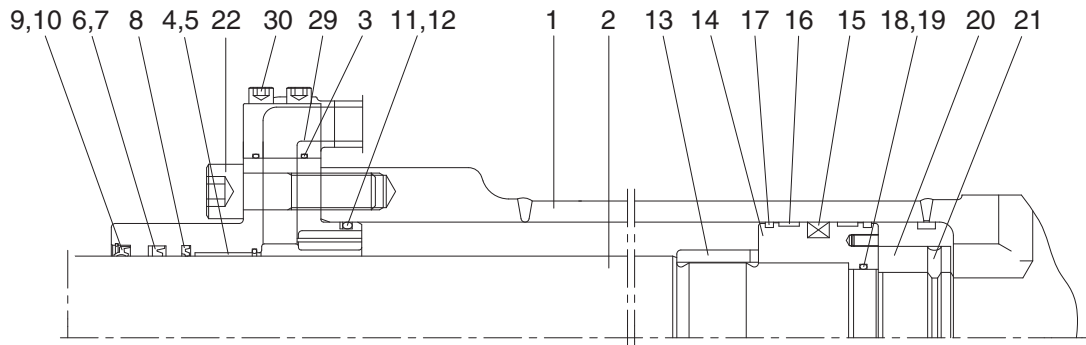

Internal detail

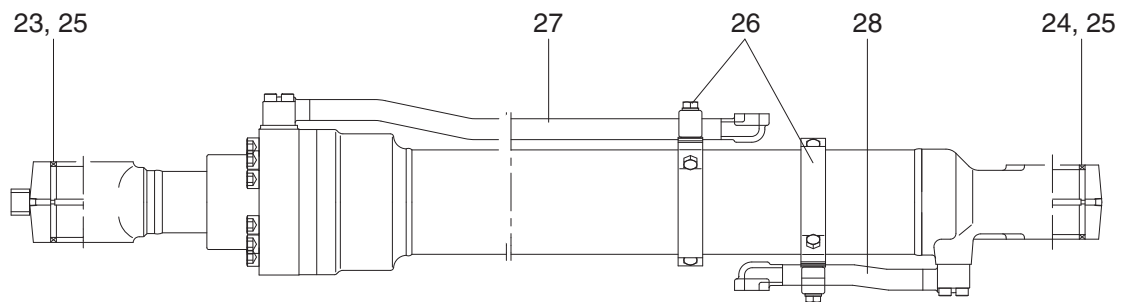

145WF8CY01

1	Tube assembly	11	O-ring	21	Hexagon socket set screw
2	Rod assembly	12	Back up ring	22	Hexagon socket head bolt
3	Gland	13	Cushion ring	23	Pin bushing
4	DD2 bushing	14	Piston	24	Pin bushing
5	Snap ring	15	Piston seal	25	Dust seal
6	Rod seal	16	Wear ring	26	Band assembly
7	Back up ring	17	Dust ring	27	Pipe assembly-R
8	Buffer ring	18	O-ring	28	Pipe assembly-B
9	Dust wiper	19	Back up ring	29	O-ring
10	Snap ring	20	Lock nut	30	Hexagon socket head bolt

(2) Arm cylinder

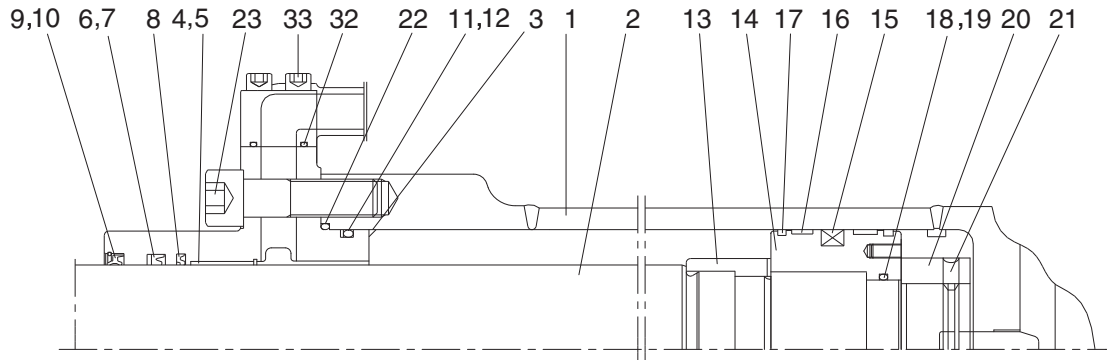

Internal detail

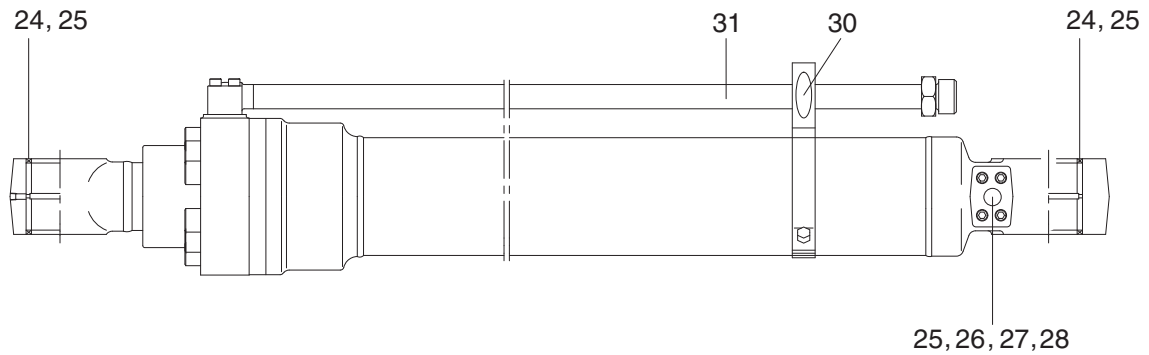

145WF8CY02

- | | | | | | |
|----|---------------|----|--------------------------|----|--------------------------|
| 1 | Tube assembly | 12 | Back up ring | 23 | Hexagon socket head bolt |
| 2 | Rod assembly | 13 | Cushion ring | 24 | Pin bushing |
| 3 | Gland | 14 | Piston | 25 | Dust seal |
| 4 | DD2 bushing | 15 | Piston seal | 26 | Check valve |
| 5 | Snap ring | 16 | Wear ring | 27 | Coil spring |
| 6 | Rod seal | 17 | Dust ring | 28 | O-ring |
| 7 | Back up ring | 18 | O-ring | 29 | Plug |
| 8 | Buffer ring | 19 | Back up ring | 30 | Band assembly |
| 9 | Dust wiper | 20 | Lock nut | 31 | Pipe assembly-R |
| 10 | Snap ring | 21 | Hexagon socket set screw | 32 | O-ring |
| 11 | O-ring | 22 | O-ring | 33 | Hexagon socket head bolt |

(3) Boom cylinder

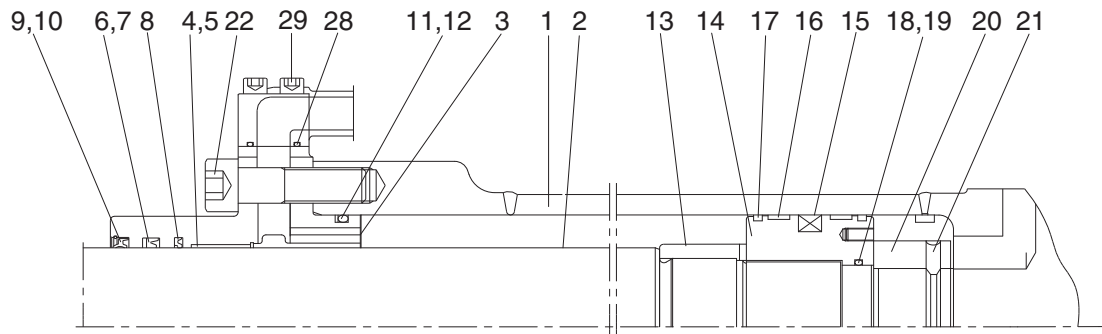

Internal detail

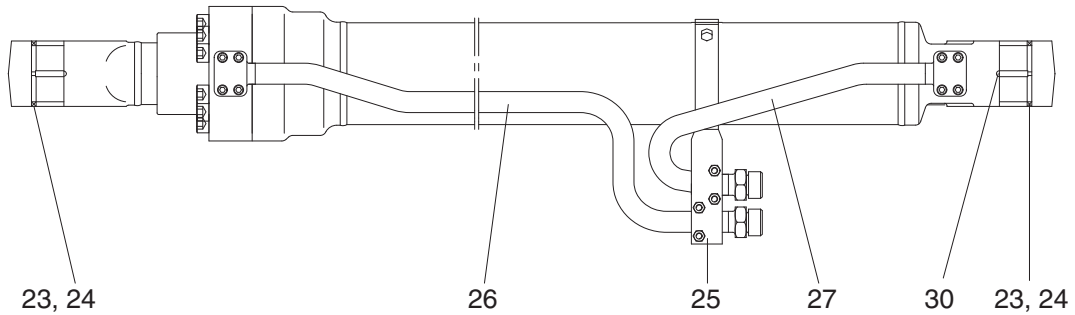

145WF8CY03

- | | | | | | |
|----|---------------|----|--------------|----|--------------------------|
| 1 | Tube assembly | 11 | O-ring | 21 | Hexagon socket set screw |
| 2 | Rod assembly | 12 | Back up ring | 22 | Hexagon socket head bolt |
| 3 | Gland | 13 | Cushion ring | 23 | Pin bushing |
| 4 | DD2 bushing | 14 | Piston | 24 | Dust seal |
| 5 | Snap ring | 15 | Piston seal | 25 | Band assembly |
| 6 | Rod seal | 16 | Wear ring | 26 | Pipe assembly-R |
| 7 | Back up ring | 17 | Dust ring | 27 | Pipe assembly-B |
| 8 | Buffer ring | 18 | O-ring | 28 | O-ring |
| 9 | Dust wiper | 19 | Back up ring | 29 | Hexagon socket head bolt |
| 10 | Snap ring | 20 | Lock nut | 30 | Socket plug |

(4) Dozer cylinder

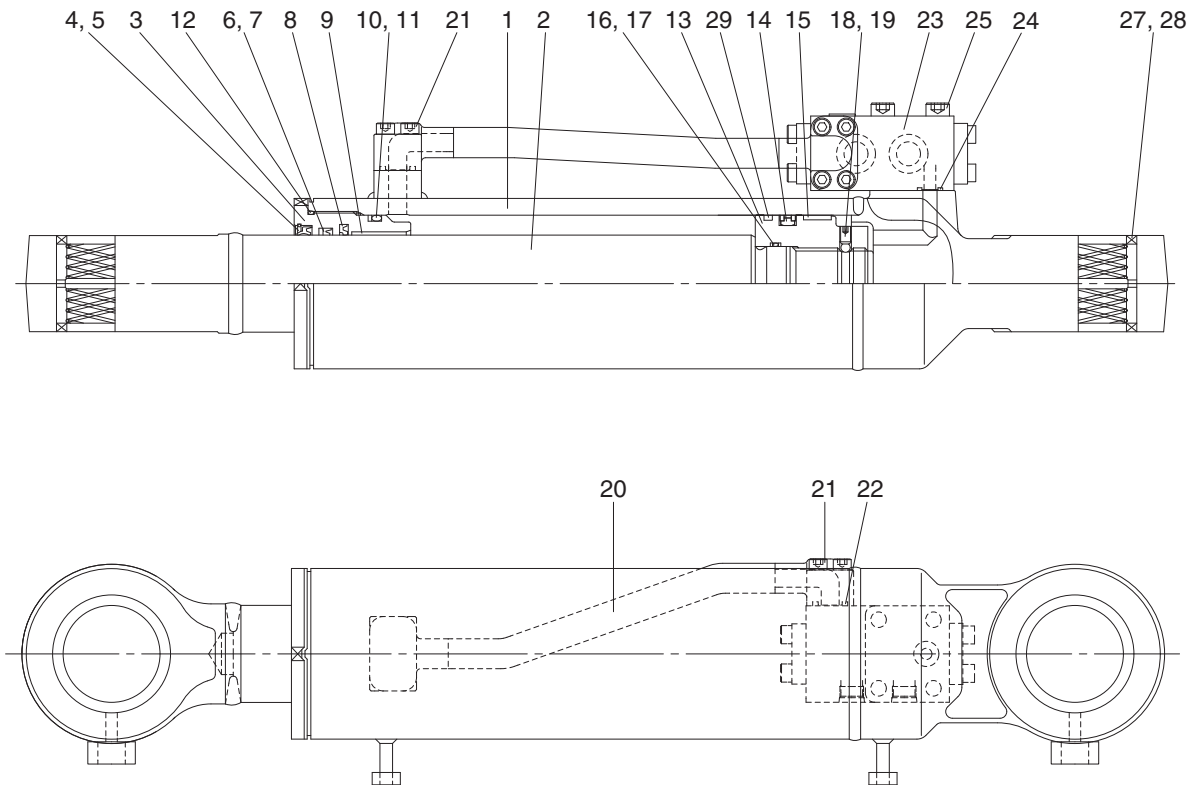

145ZF8CY05

1	Tube assembly	11	Back up ring	21	Hexagon socket head bolt
2	Rod assembly	12	O-ring	22	O-ring
3	Gland	13	Piston	23	Check valve assembly
4	Dust wiper	14	Piston seal	24	O-ring
5	Retainer ring	15	Wear ring	25	Hexagon socket head bolt
6	Rod seal	16	O-ring	26	Hexagon socket head bolt
7	Back up ring	17	Back up ring	27	Pin bushing
8	Buffer ring	18	Steel ball	28	Dust seal
9	Dry bearing	19	Set screw	29	Dust ring
10	O-ring	20	Pipe assembly		

2) TOOLS AND TIGHTENING TORQUE

(1) Tools

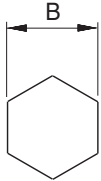
Tool name	Remark		
Allen wrench	6		
	8		
	14		
	17		
Spanner	7		
	8		
(-) Driver	Small and large sizes		
Torque wrench	Capable of tightening with the specified torques		

(2) Tightening torque

Part name		Item	Size	Torque	
				kgf · m	lbf · ft
Socket head bolt	Bucket cylinder (★1)	22	M14	15±2.0	108±14.5
	Boom cylinder (★1)	22	M14	15±2.0	108±14.5
	Arm cylinder (★1)	23	M16	23±2.0	166±14.5
Check valve mounting socket head bolt	Dozer cylinder	25	M10	5.4±0.5	39.1±3.6
Pipe mounting socket head bolt	Bucket	30	M10	5.4±0.5	39.1±3.6
	Boom	29	M8	2.7±0.3	19.6±2.2
	Arm	33	M10	5.4±0.5	39.1±3.6
	Dozer cylinder	21	M8	2.7±0.3	19.5±2.2
Lock nut	Bucket cylinder	20	M45	100±10.0	723±72.3
	Boom cylinder	20	M52		
	Arm cylinder	20	M56		
Piston	Bucket cylinder	14	-	150±15.0	1085±109
	Boom cylinder	14			
	Arm cylinder	14			
	Dozer cylinder	13	M52		
Gland	Dozer cylinder	3	M105	85±8.5	615±61.5
Set screw	Bucket cylinder	21	M8	2.7±0.3	19.5±2.2
	Boom cylinder	21	M8	2.7±0.3	19.5±2.2
	Arm cylinder	21	M8	2.7±0.3	19.5±2.2
	Dozer cylinder	19	M8	2.7±0.3	19.5±2.2

※ Apply loctite #243 (★1) on the thread before tightening.

3) DISASSEMBLY

(1) Remove cylinder head and piston rod

※ Procedures are based on the bucket cylinder.

① Hold the clevis section of the tube in a vise.

※ Use mouth pieces so as not to damage the machined surface of the cylinder tube. Do not make use of the outside piping as a locking means.

② Pull out rod assembly (2) about 200mm (7.1in). Because the rod assembly is rather heavy, finish extending it with air pressure after the oil draining operation.

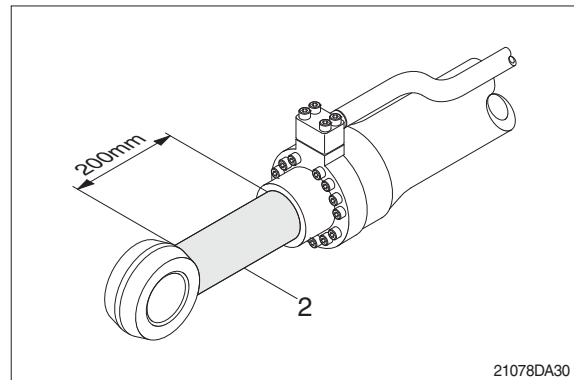

③ Loosen and remove socket bolts (22) of the gland in sequence.

※ Cover the extracted rod assembly (2) with rag to prevent it from being accidentally damaged during operation.

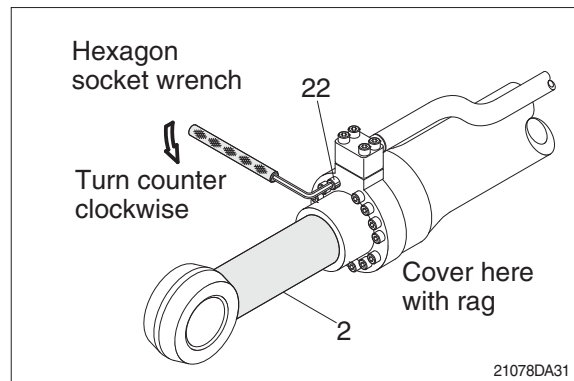

④ Draw out cylinder head and rod assembly together from tube assembly (1).

※ Since the rod assembly is heavy in this case, lift the tip of the rod assembly (2) with a crane or some means and draw it out. However, when rod assembly (2) has been drawn out to approximately two thirds of its length, lift it in its center to draw it completely.

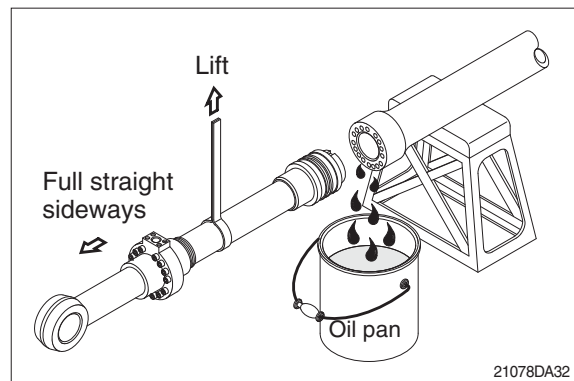

Note that the plated surface of rod assembly (2) is to be lifted. For this reason, do not use a wire sling and others that may damage it, but use a strong cloth belt or a rope.

- ⑤ Place the removed rod assembly on a wooden V-block that is set level.
- ※ Cover a V-block with soft rag.

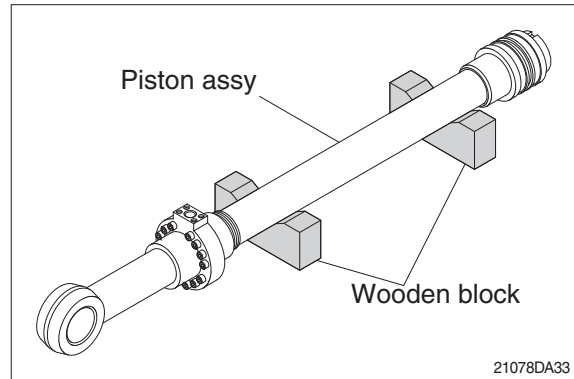

(2) Remove piston and cylinder head

- ① Remove set screw (21).
- ※ Since set screw (21) and lock nut (20) is tightened to a high torque, use a hydraulic and power wrench that utilizes a hydraulic cylinder, to remove the lock set screw (21) and lock nut (20).
- ② Remove piston assembly (14), back up ring (19), and O-ring (18).

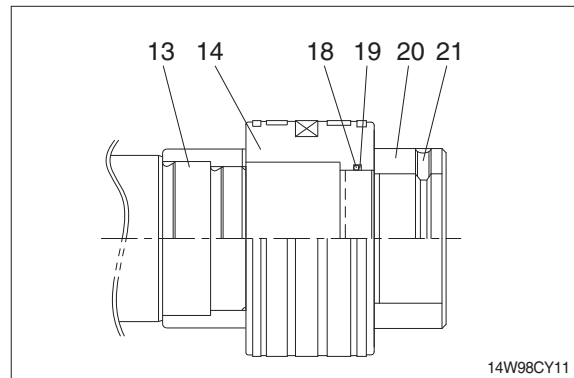

- ③ Remove the cylinder head assembly from rod assembly (2).
 - ※ If it is too heavy to move, move it by striking the flanged part of cylinder head with a plastic hammer.
 - ※ Pull it straight with cylinder head assembly lifted with a crane.
- Exercise care so as not to damage the lip of rod bushing (4) and packing (5,6,7,8,9,10) by the threads of rod assembly (2).

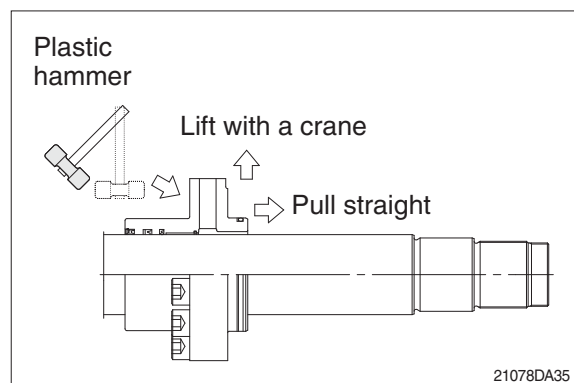

(3) Disassemble the piston assembly

- ① Remove wear ring (16).
 - ② Remove dust ring (17) and piston seal (15).
- ※ Exercise care in this operation not to damage the grooves.

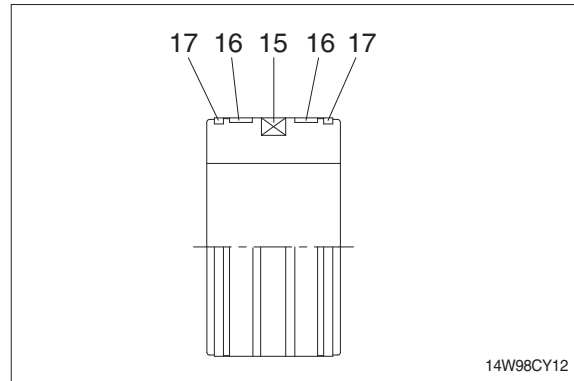

(4) Disassemble cylinder head assembly

- ① Remove back up ring (12) and O-ring (11).
 - ② Remove snap ring (10), dust wiper (9).
 - ③ Remove back up ring (7), rod seal (6) and buffer ring (8).
- ※ Exercise care in this operation not to damage the grooves.
- ※ Do not remove seal and ring, if does not damaged.
- ※ Do not remove bushing (4).

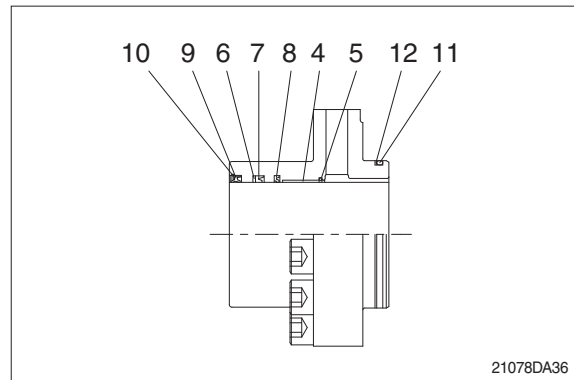

3) ASSEMBLY

(1) Assemble cylinder head assembly

- ※ Check for scratches or rough surfaces if found smooth with an oil stone.
- ① Coat the inner face of gland (3) with hydraulic oil.

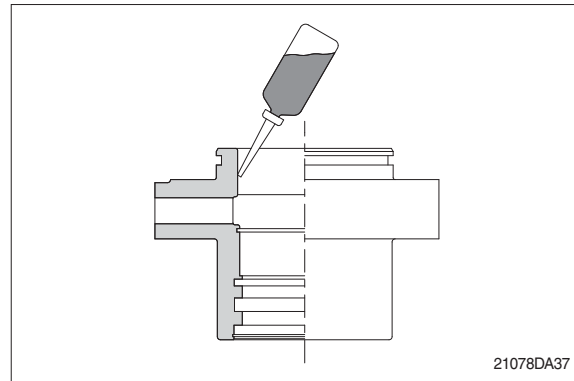

- ② Coat dust wiper (9) with grease and fit dust wiper (9) to the bottom of the hole of dust wiper.
At this time, press a pad metal to the metal ring of dust wiper.
- ③ Fit snap ring (10) to the stop face.

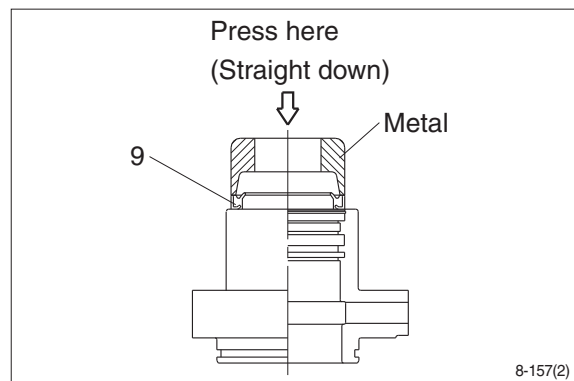

- ④ Fit back up ring (7), rod seal (6) and buffer ring (8) to corresponding grooves, in that order.
※ Coat each packing with hydraulic oil before fitting it.
※ Insert the backup ring until one side of it is inserted into groove.

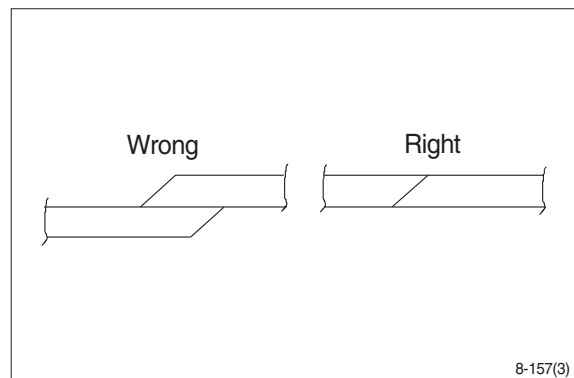

- ※ Rod seal (6) has its own fitting direction. Therefore, confirm it before fitting them.
- ※ Fitting rod seal (6) upside down may damage its lip. Therefore check the correct direction that is shown in fig.

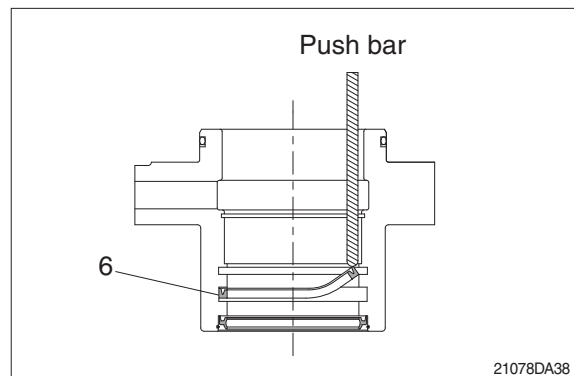

- ⑤ Fit back up ring (12) to gland (3).
- ※ Put the backup ring in the warm water of 30~50°C.
- ⑥ Fit O-ring (11) to gland (3).

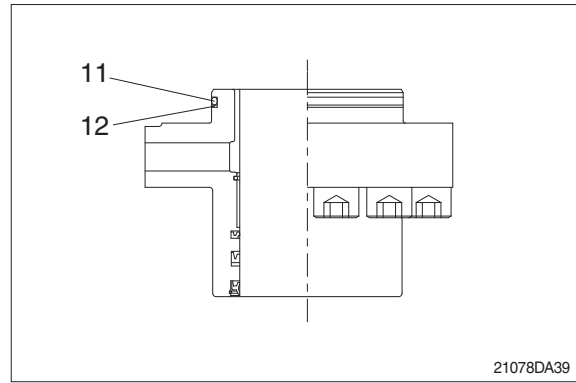

(2) Assemble piston assembly

- ※ Check for scratches or rough surfaces. If found smooth with an oil stone.
- ① Coat the outer face of piston (14) with hydraulic oil.

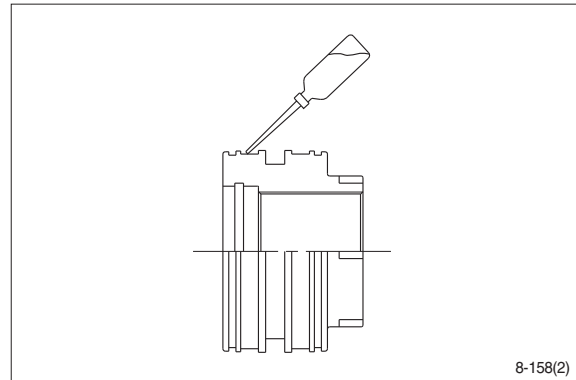

- ② Fit piston seal (15) to piston.
- ※ Put the piston seal in the warm water of 60~100°C for more than 5 minutes.
- ※ After assembling the piston seal, press its outer diameter to fit in.

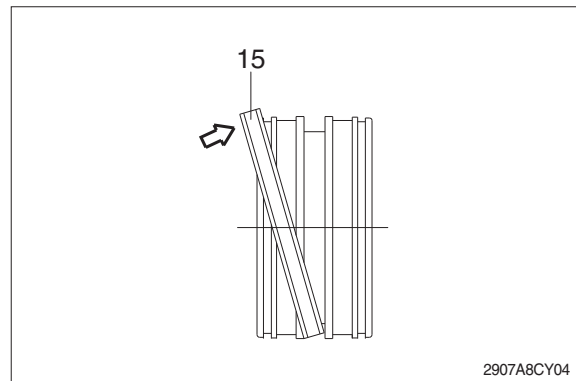

- ③ Fit wear ring (16) and dust ring (17) to piston (14).

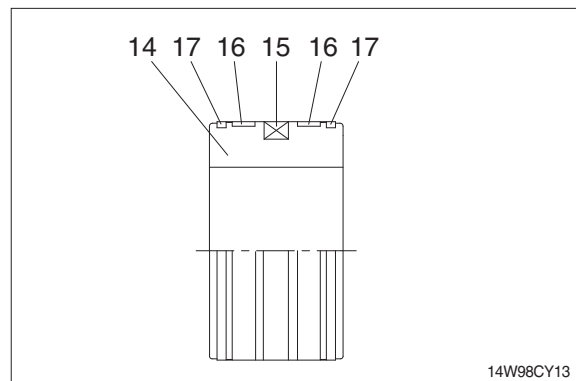

(3) Install piston and cylinder head

- ① Fix the rod assembly to the work bench.
- ② Apply hydraulic oil to the outer surface of rod assembly (2), the inner surface of piston and cylinder head.
- ③ Insert cylinder head assembly to rod assembly.

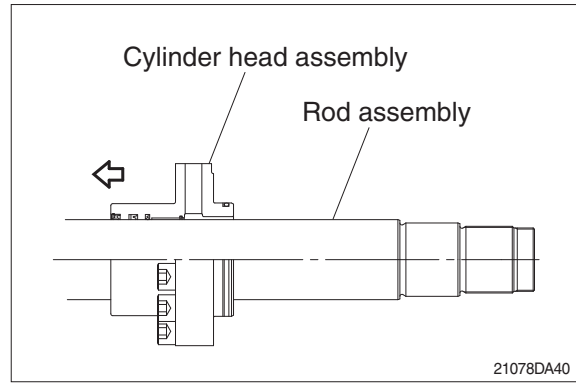

- ④ Insert cushion ring (13) to rod assembly.
- ※ Note that cushion ring (13) has a direction in which it should be fitted.

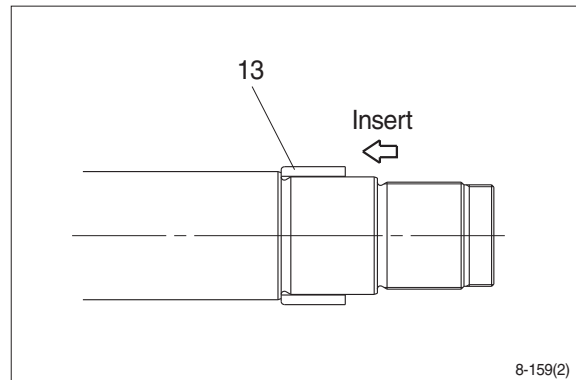

- ⑤ Fit piston assembly to rod assembly.
- Tightening torque : $150 \pm 15 \text{ kgf} \cdot \text{m}$
($1085 \pm 108 \text{ lbf} \cdot \text{ft}$)

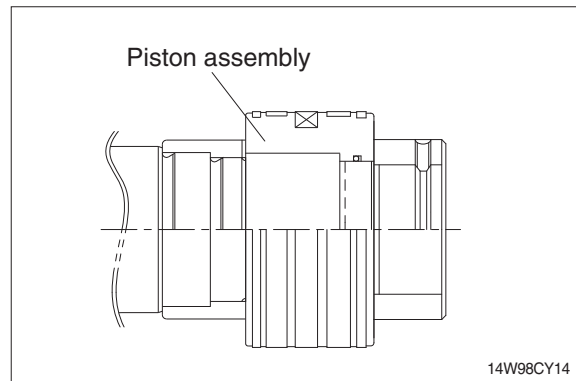

- ⑥ Fit lock nut (20) and tighten the set screw (21).
- Tightening torque :

Item		kgf · m	lbf · ft
20	Bucket	100 ± 10	723 ± 72.3
	Boom		
	Arm		
21		2.7 ± 0.3	19.6 ± 2.2

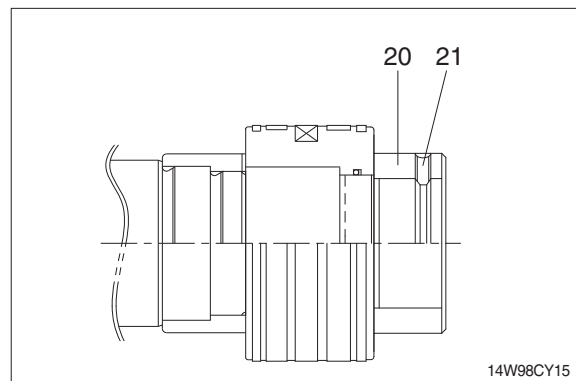

(3) Overall assemble

- ① Place a V-block on a rigid work bench.
Mount the tube assembly (1) on it and fix the assembly by passing a bar through the clevis pin hole to lock the assembly.
- ② Insert the rod assembly in to the tube assembly, while lifting and moving the rod assembly with a crane.
 - ※ Be careful not to damage piston seal by thread of tube assembly.
- ③ Match the bolt holes in the cylinder head flange to the tapped holes in the tube assembly and tighten socket bolts to a specified torque.
 - ※ Refer to the table of tightening torque.

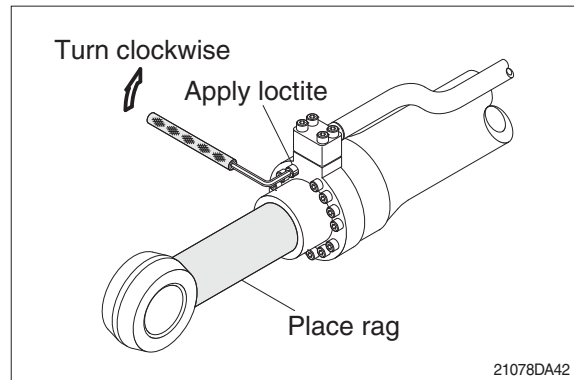
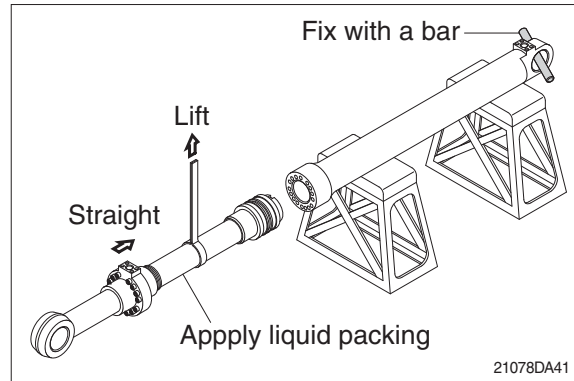

GROUP 10 UNDERCARRIAGE

1. TRACK LINK

1) REMOVAL

(1) Move track link until master pin is over front idler in the position put wooden block as shown.

(2) Loosen tension of the track link.

※ If track tension is not relieved when the grease valve is loosened, move the machine backwards and forwards.

※ Unscrew the grease nipple after release the tension by pushing the poppet only when necessarily required.

Grease leaking hole is not existing. So, while unscrew the grease nipple, grease is not leaking until the grease nipple is completely coming out. If the tension is not released in advance, the grease nipple can be suddenly popped out by pressurized grease.

(3) Push out master pin by using a suitable tool.

(4) Move the machine slowly in reverse, and lay out track link assembly (1).

※ Jack up the machine and put wooden block under the machine.

※ Don't get close to the sprocket side as the track shoe plate may fall down on your feet.

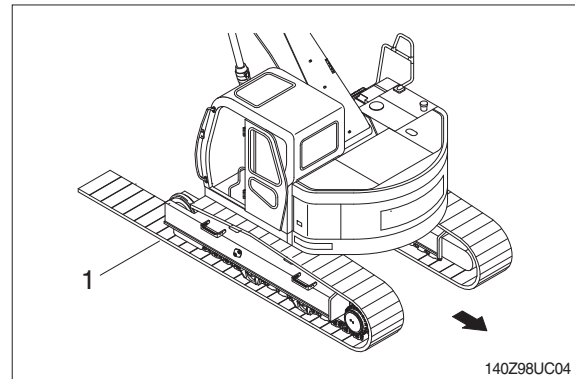
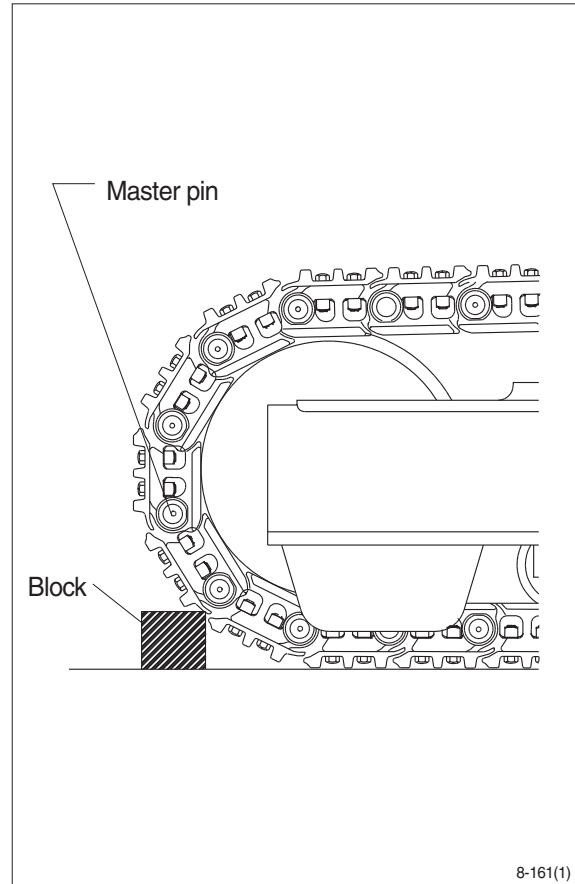

2) INSTALL

(1) Carry out installation in the reverse order to removal.

※ Adjust the tension of the track link.

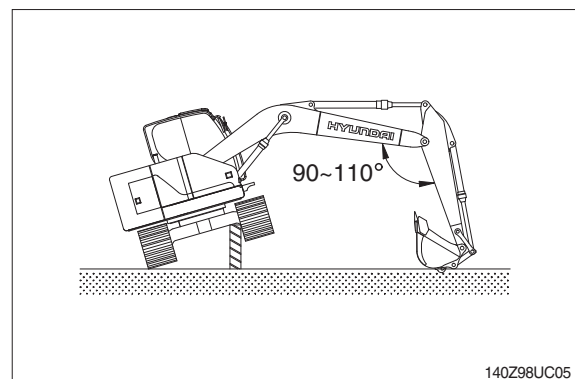

2. CARRIER ROLLER

1) REMOVAL

- (1) Loosen tension of the track link.

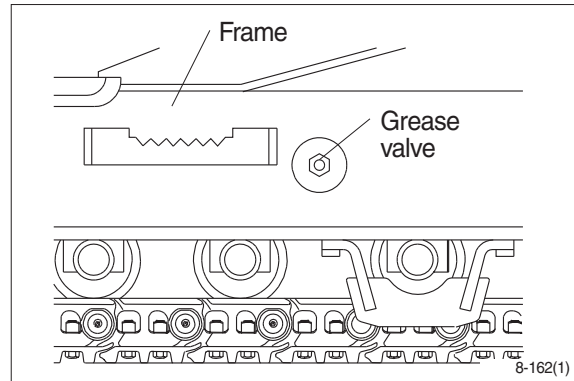

- (2) Jack up the track link height enough to permit carrier roller removal.

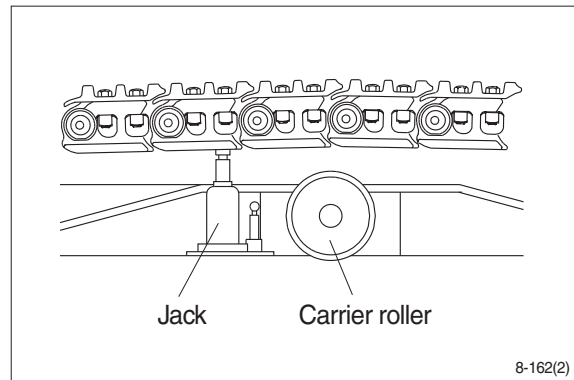

- (3) Loosen the lock nut (1).
 - Tightening torque : $29.7 \pm 4.4 \text{ kgf} \cdot \text{m}$
($215 \pm 31.8 \text{ lbf} \cdot \text{ft}$)
- (4) Open bracket(2) with a screwdriver, push out from inside, and remove carrier roller assembly.
 - Weight : 20 kg (45 lb)

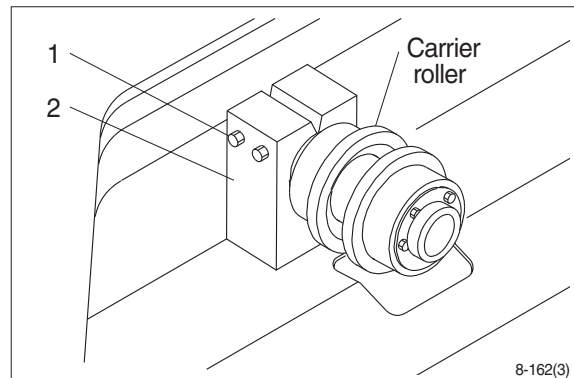

2) INSTALL

- (1) Carry out installation in the reverse order to removal.

3. TRACK ROLLER

1) REMOVAL

- (1) Loosen tension of the track link.

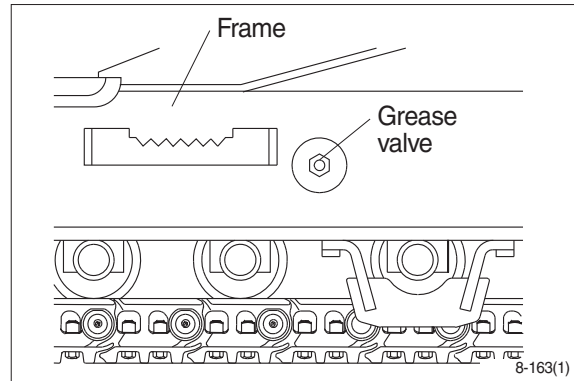

- (2) Using the work equipment, push up track frame on side which is to be removed.
※ After jack up the machine, set a block under the unit.

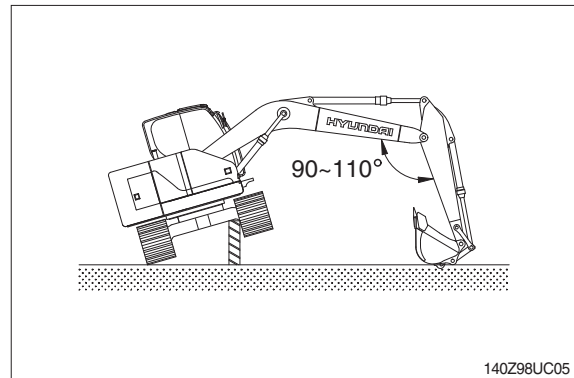

- (3) Remove the mounting bolt (1) and draw out the track roller (2).
 - Weight : 35.1 kg (77.4 lb)
 - Tightening torque : 29.6 ± 3.2 kgf · m
(214 ± 23.1 lbf · ft)

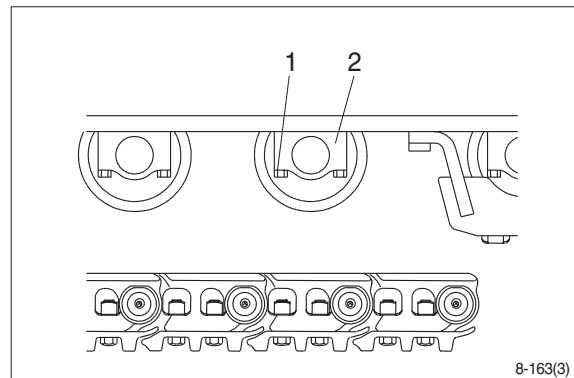

2) INSTALL

- (1) Carry out installation in the reverse order to removal.

4. IDLER AND RECOIL SPRING

1) REMOVAL

- (1) Remove the track link.
For detail, see removal of track link.

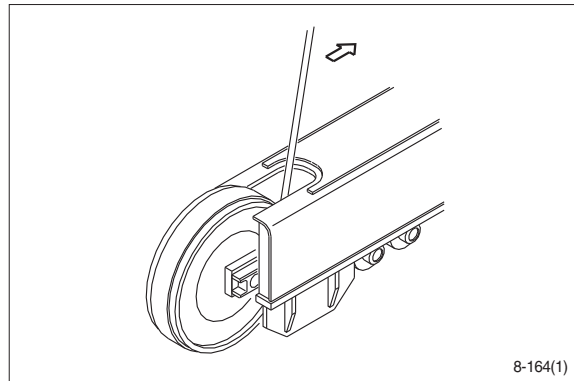

- (2) Sling the recoil spring (1) and pull out idler and recoil spring assembly from track frame, using a pry.
 - Weight : 192 kg (423 lb)

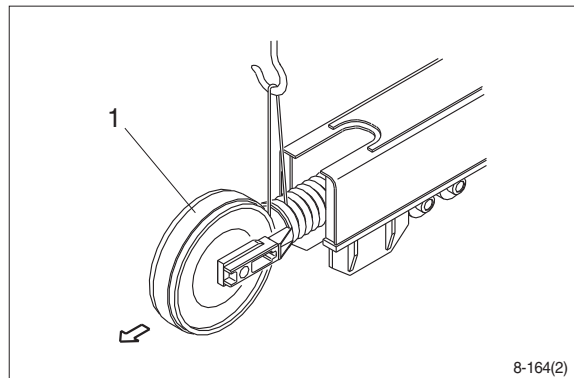

- (3) Remove the bolts (2), washers (3) and separate idler from recoil spring.
 - Tightening torque : 29.7 ± 4.5 kgf · m
(215 ± 32.5 lbf · ft)

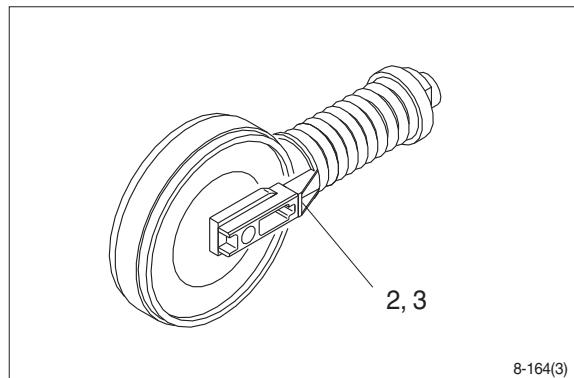

2) INSTALL

- (1) Carry out installation in the reverse order to removal.
 - ※ Make sure that the boss on the end face of the recoil cylinder rod is in the hole of the track frame.

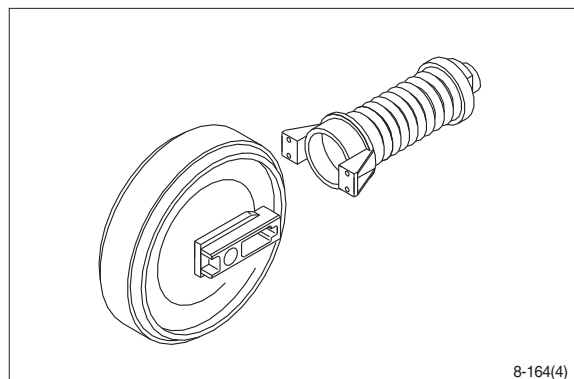

3) DISASSEMBLY AND ASSEMBLY OF IDLER

(1) Structure

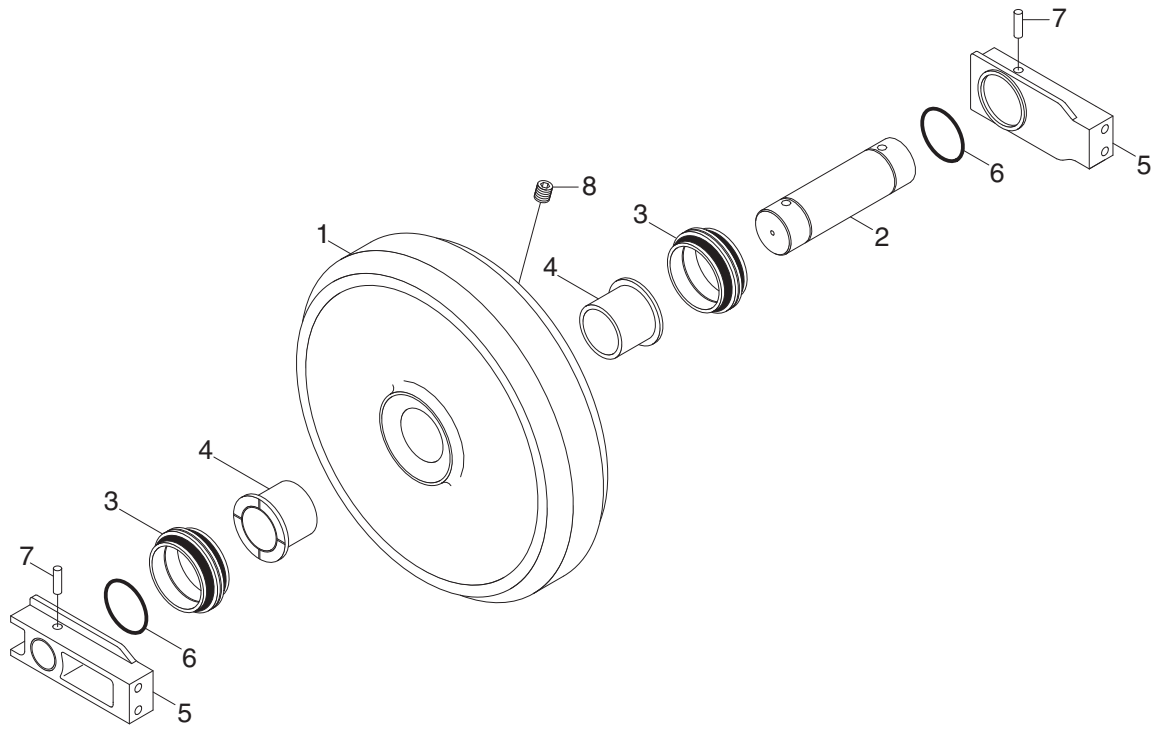

21078DA43

- 1 Shell
- 2 Shaft
- 3 Seal assembly

- 4 Bushing
- 5 Bracket
- 6 O-ring

- 7 Spring pin
- 8 Plug

(2) Disassembly

- ① Remove plug (8) and drain oil.
- ② Draw out the spring pin (7), using a press.

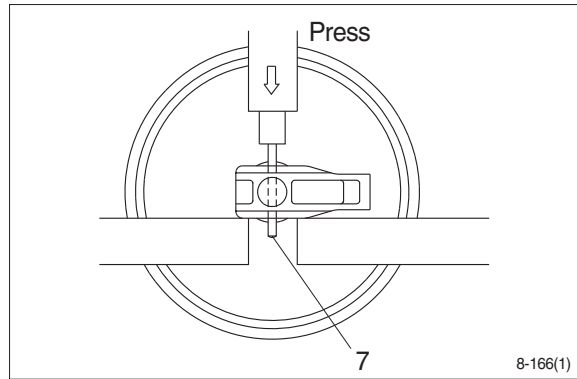

- ③ Pull out the shaft (2) with a press.
- ④ Remove seal (3) from idler (1) and bracket (5).
- ⑤ Remove O-ring (6) from shaft.

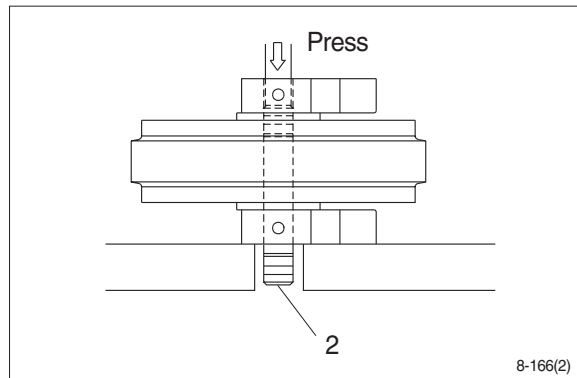

- ⑥ Remove the bushing (4) from idler, using a special tool.
Only remove bushing if replacement is necessary.

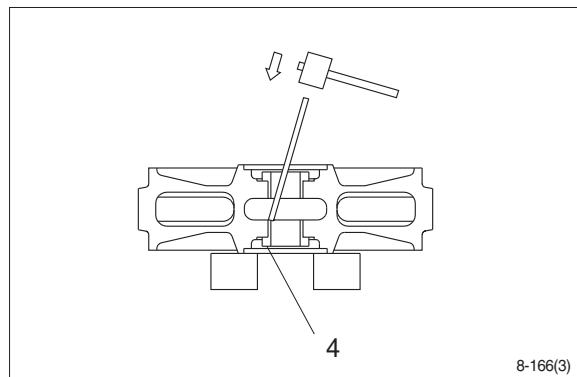

(3) Assembly

- ※ Before assembly, clean the parts.
- ※ Coat the sliding surfaces of all parts with oil.

- ① Cool up bushing (4) fully by some dry ice and press it into shell (1).

Do not press it at the normal temperature, or not knock in with a hammer even after the cooling.

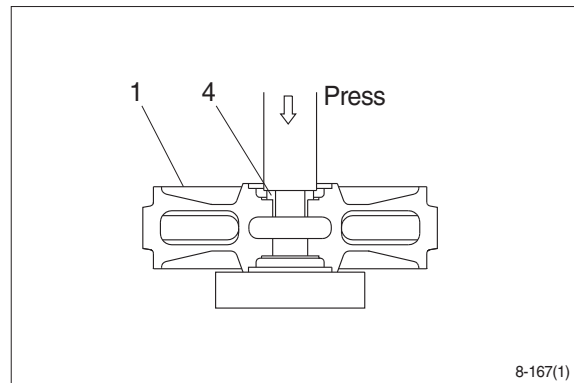

- ② Coat O-ring (6) with grease thinly, and install it to shaft (2).
- ③ Insert shaft (2) into bracket (5) and drive in the spring pin (7).

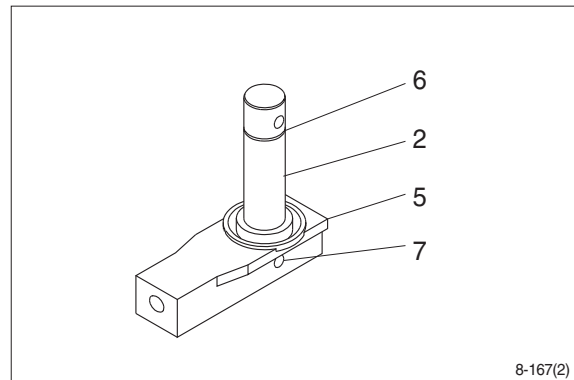

- ④ Install seal (3) to shell (1) and bracket (5).

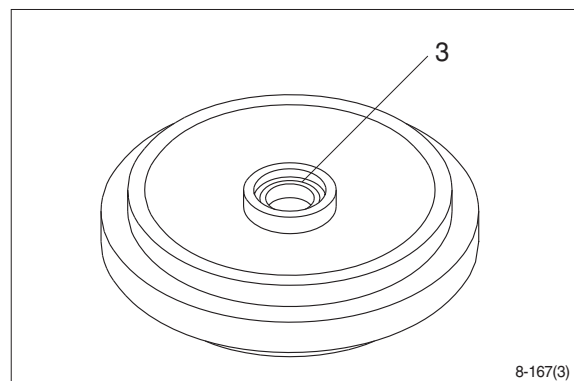

- ⑤ Install shaft (2) to shell (1).

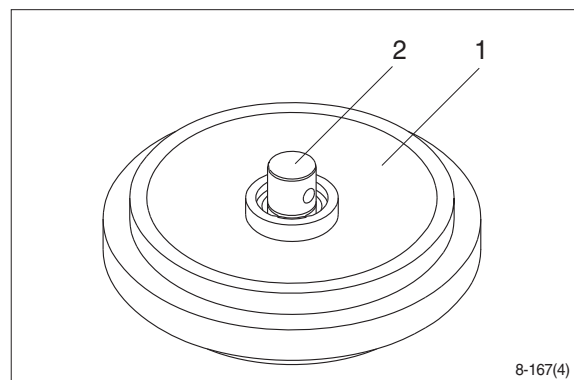

⑥ Install bracket (5) attached with seal (3).

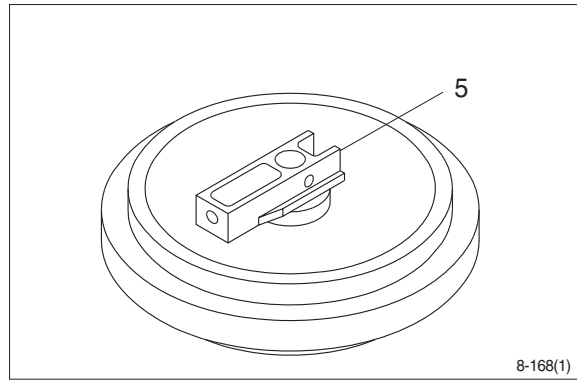

⑦ Knock in the spring pin (7) with a hammer.

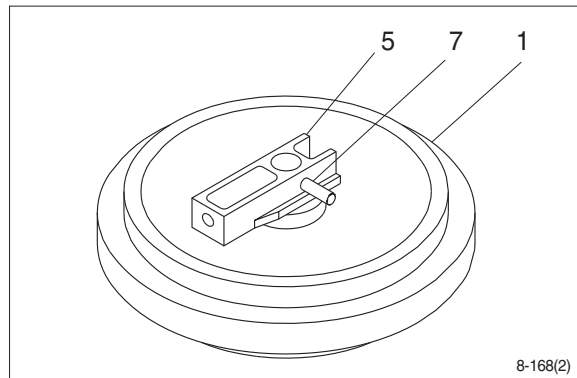

⑧ Lay bracket (5) on its side.
Supply engine oil to the specified level,
and tighten plug (8).

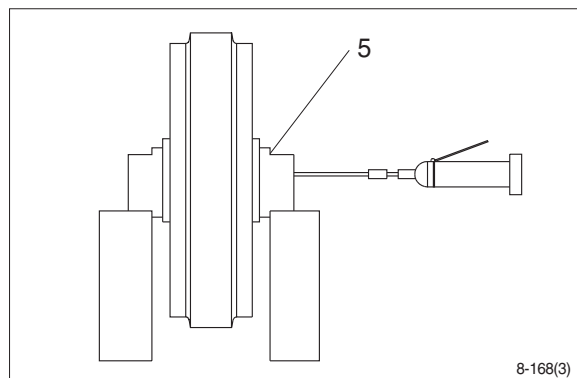

4) DISASSEMBLY AND ASSEMBLY OF RECOIL SPRING

(1) Structure

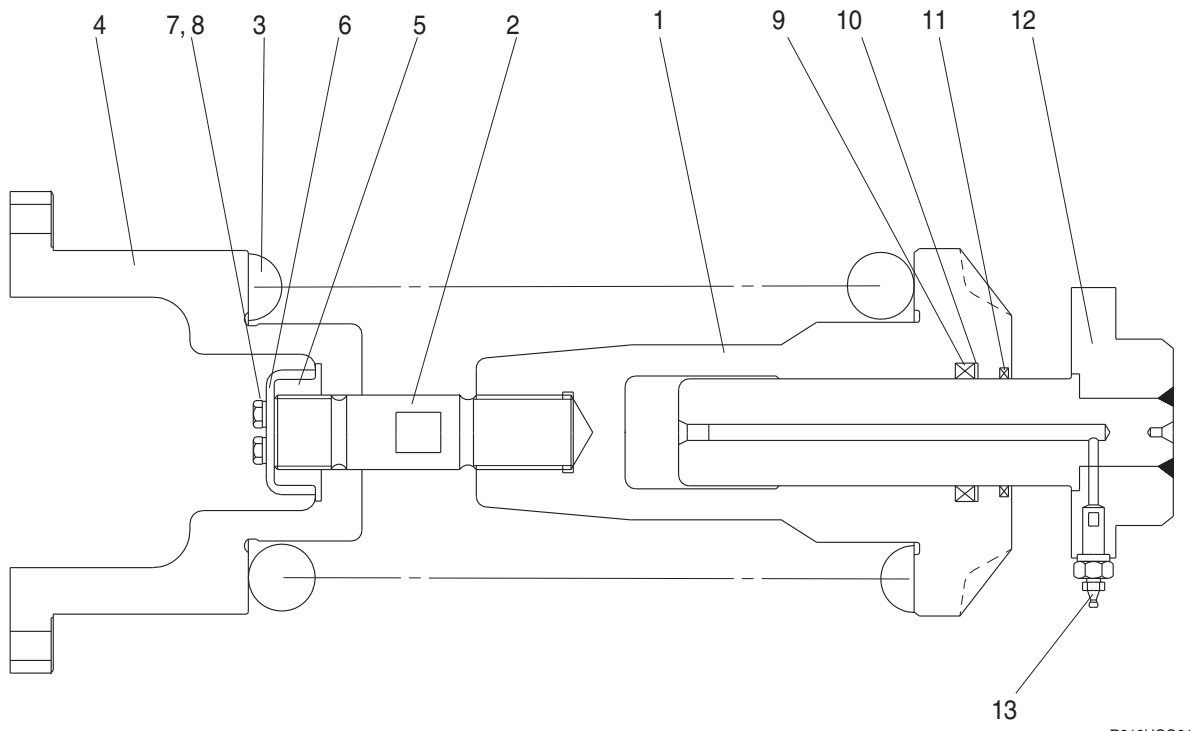

R210UCG01

- 1 Body
- 2 Tie bar
- 3 Spring
- 4 Bracket
- 5 Lock nut

- 6 Lock plate
- 7 Bolt
- 8 Spring washer
- 9 Rod seal
- 10 Back up ring

- 11 Dust seal
- 12 Rod assembly
- 13 Grease valve

(2) Disassembly

- ① Apply pressure on spring (3) with a press.
 - ※ The spring is under a large installed load. This is dangerous, so be sure to set properly.
 - Spring set load : 11132 kg (24542 lb)
- ② Remove bolt (7), spring washer (8) and lock plate (6).
- ③ Remove lock nut (5).

Take enough notice so that the press which pushes down the spring, should not be slipped out in its operation.
- ④ Lighten the press load slowly and remove bracket (4) and spring (3).

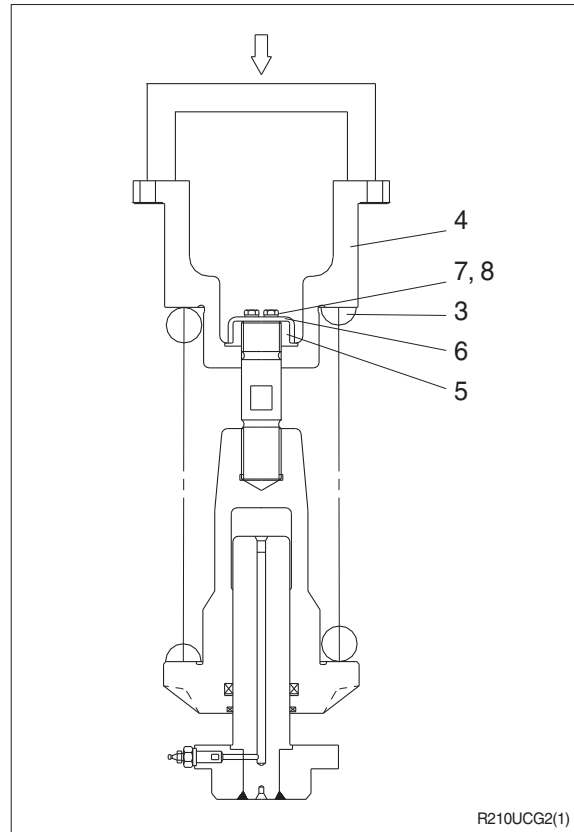

- ⑤ Remove rod (12) from body (1).
- ⑥ Remove grease valve (13) from rod (12).

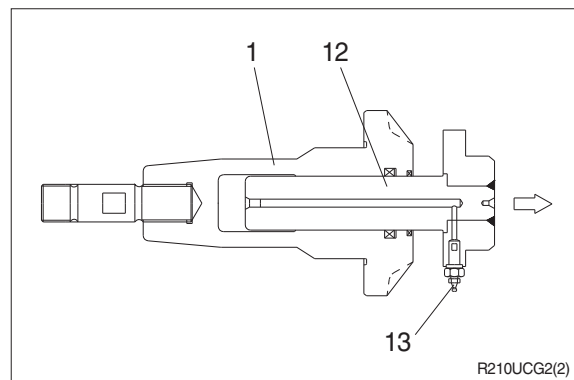

- ⑦ Remove rod seal (9), back up ring (10) and dust seal (11).

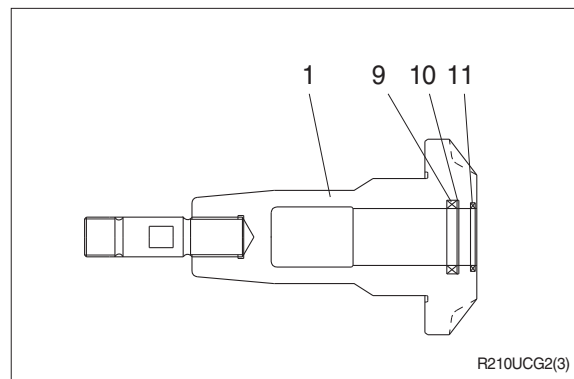

(3) Assembly

Install dust seal (11), back up ring (10) and rod seal (9) to body (1).

- ※ When installing dust seal (11) and rod seal (9), take full care so as not to damage the lip.

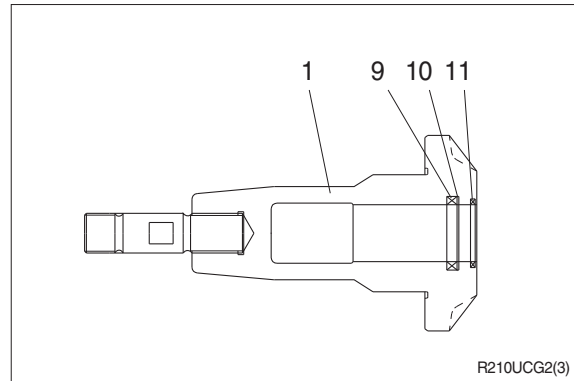

- ② Pour grease into body (1), then push in rod (12) by hand.

After take grease out of grease valve mounting hole, let air out.

- ※ If air letting is not sufficient, it may be difficult to adjust the tension of crawler.

- ③ Fit grease valve (13) to rod (12).

- Tightening torque : $13 \pm 1.0 \text{ kgf} \cdot \text{m}$
($94 \pm 7.2 \text{ lbf} \cdot \text{ft}$)

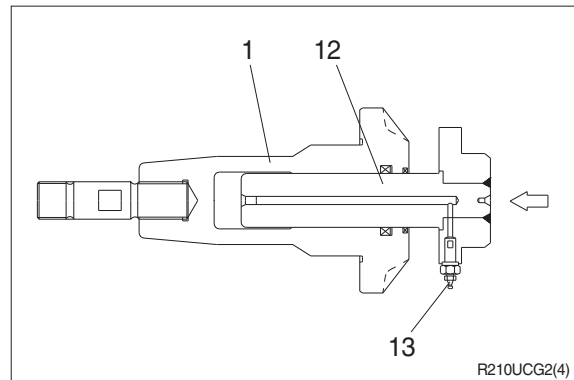

- ④ Install spring (3) and bracket (4) to body (1).

- ⑤ Apply pressure to spring (3) with a press and tighten lock nut (5).

- ※ Apply sealant before assembling.

- ※ During the operation, pay attention specially to prevent the press from slipping out.

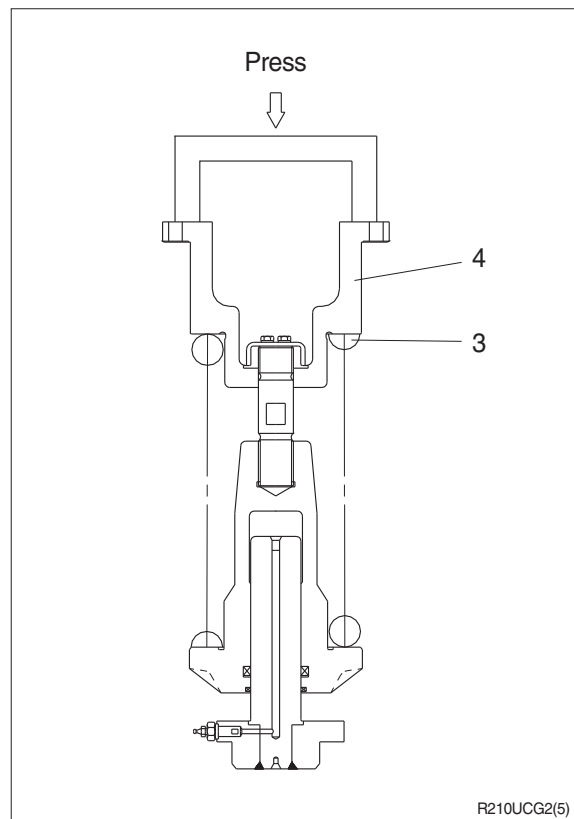

- ⑥ Lighten the press load and confirm the set length of spring (3).
- ⑦ After the setting of spring (3), install lock plate (6), spring washer (8) and bolt (7).

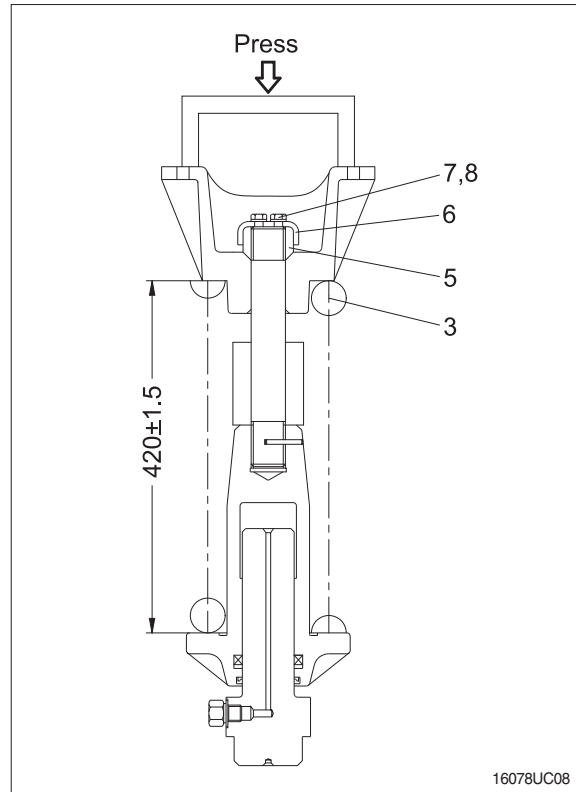

GROUP 11 WORK EQUIPMENT

1. STRUCTURE

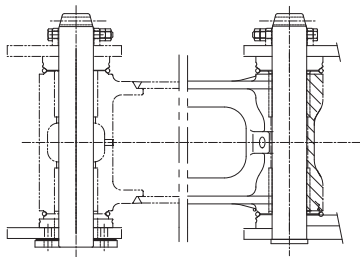
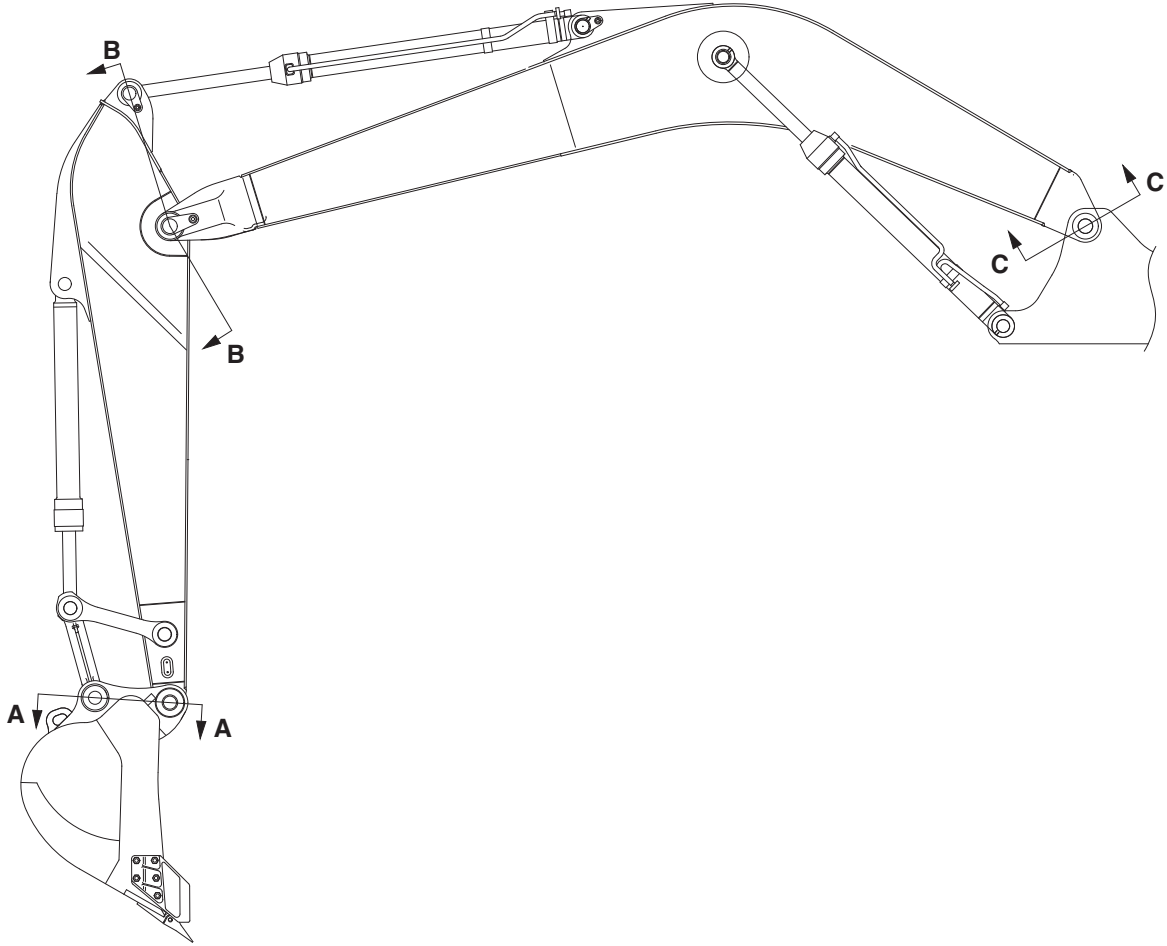

SECTION A

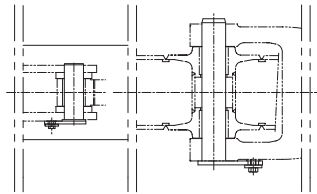

SECTION B

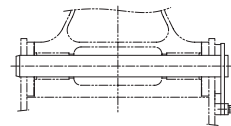

SECTION C

21078D 44

2. REMOVAL AND INSTALL

1) BUCKET ASSEMBLY

(1) Removal

- ① Lower the work equipment completely to ground with back of bucket facing down.

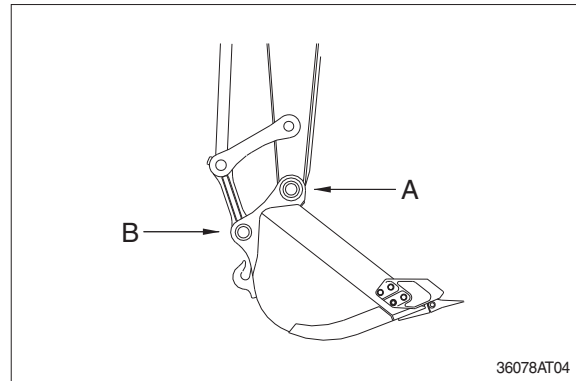

- ② Remove nut (1), bolt (2) and draw out the pin (B).

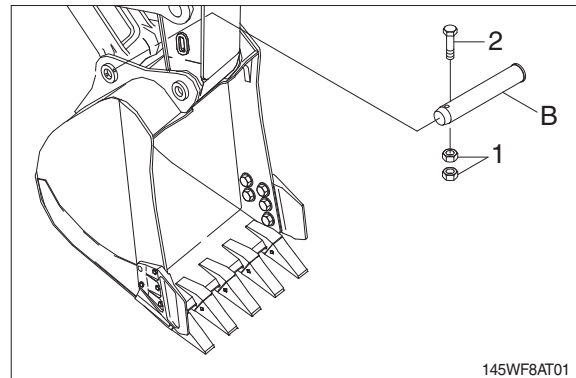

- ③ Remove nut (3), bolt (4) and draw out the pin (A) then remove the bucket assembly.
· Weight : 480 kg (1060 lb)

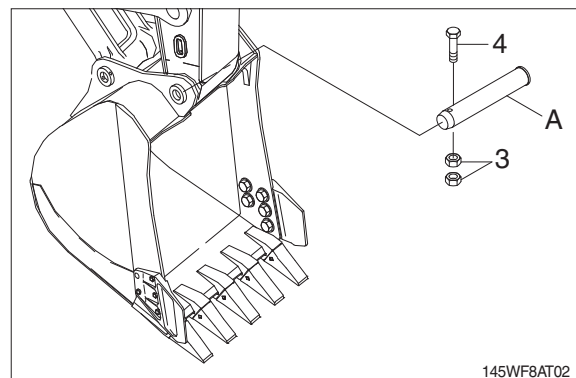

(2) Install

- ① Carry out installation in the reverse order to removal.

▲ When aligning the mounting position of the pin, do not insert your fingers in the pin hole.

- ※ Adjust the bucket clearance.
For detail, see operation manual.

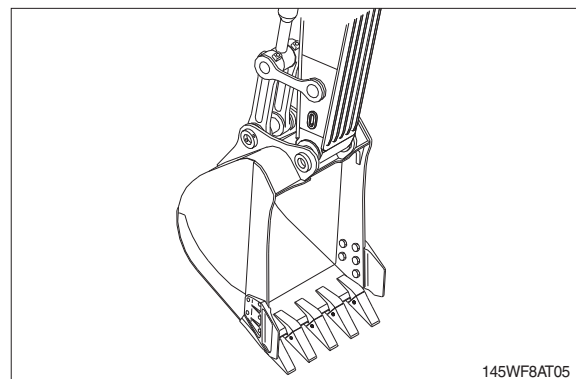

2) ARM ASSEMBLY

(1) Removal

※ Loosen the breather slowly to release the pressure inside the hydraulic tank.

▲ Escaping fluid under pressure can penetrate the skin causing serious injury.

① Remove bucket assembly.

For details, see removal of bucket assembly.

② Disconnect bucket cylinder hose (1).

▲ Fit blind plugs (5) in the piping at the chassis end securely to prevent oil from spurting out when the engine is started.

③ Sling arm cylinder assembly, remove spring, pin stopper and pull out pin.

※ Tie the rod with wire to prevent it from coming out.

④ For details, see removal of arm cylinder assembly.

Place a wooden block under the cylinder and bring the cylinder down to it.

⑤ Remove bolt (2), plate (3) and pull out the pin (4) then remove the arm assembly.

※ · Weight : 570 kg (1260 lb)

When lifting the arm assembly, always lift the center of gravity.

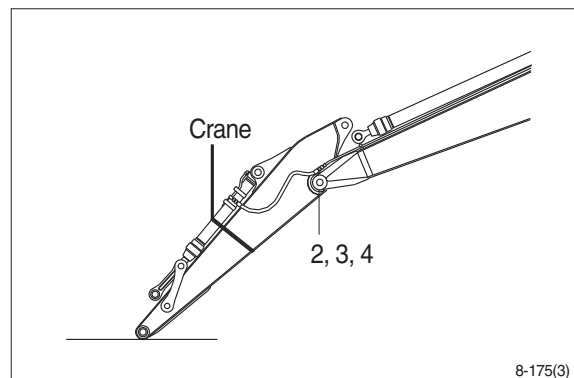
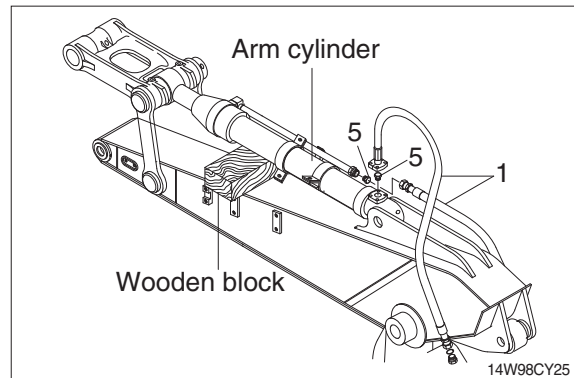
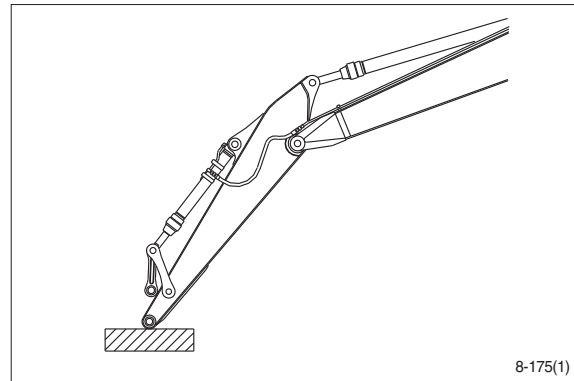

(2) Install

① Carry out installation in the reverse order to removal.

▲ When lifting the arm assembly, always lift the center of gravity.

※ Bleed the air from the cylinder.

3) BOOM CYLINDER

(1) Removal

- ① Remove arm and bucket assembly.
For details, see removal of arm and bucket assembly.
- ② Remove boom cylinder assembly from boom.
For details, see removal of arm cylinder assembly.

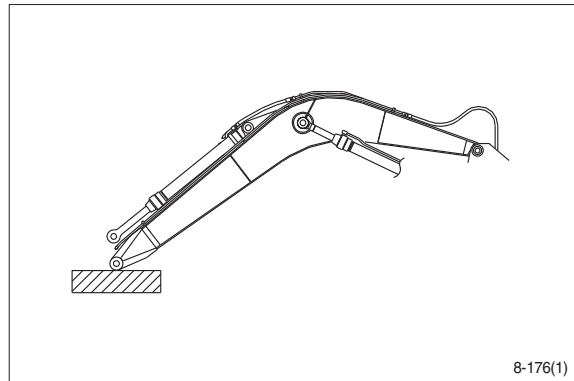

- ③ Disconnect head lamp wiring.
- ④ Disconnect bucket cylinder hose (2) and arm cylinder hose (1).
※ When the hose are disconnected, oil may spurt out.
- ⑤ Sling boom assembly (3).

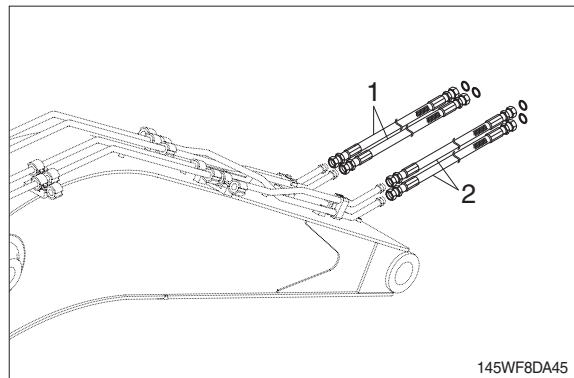

- ⑥ Remove bolt (4), plate (5) and pull out the pin (6) then remove boom assembly.
· Weight : 1020 kg (2250 lb)
※ When lifting the boom assembly always lift the center of gravity.

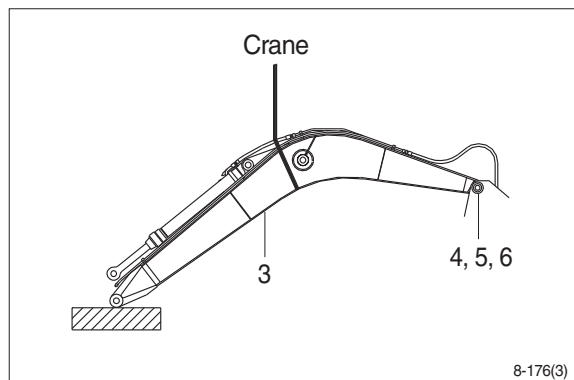

(2) Install

- ① Carry out installation in the reverse order to removal.
- ▲ When lifting the arm assembly, always lift the center of gravity.
- ※ Bleed the air from the cylinder.

