

## SECTION 4 ELECTRICAL SYSTEM

Group 1 Component Location .....	4-1
Group 2 Electrical Circuit .....	4-3
Group 3 Electrical Component Specification .....	4-22
Group 4 Connectors .....	4-33

## GROUP 1 COMPONENT LOCATION

### 1. LOCATION 1

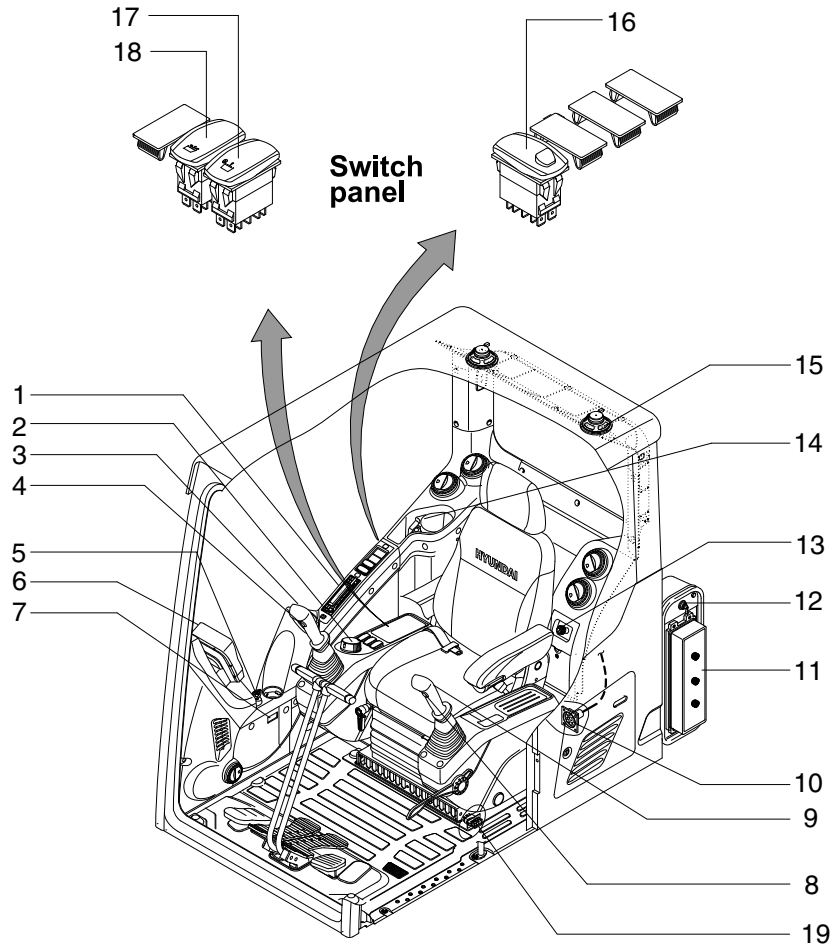

140SA4EL01

- |   |                          |    |                         |    |                              |
|---|--------------------------|----|-------------------------|----|------------------------------|
| 1 | Radio & USB player       | 8  | Power max switch (null) | 15 | Speaker                      |
| 2 | Accel dial               | 9  | One touch decel switch  | 16 | Quick clamp switch           |
| 3 | Horn switch              | 10 | RS232 service socket    | 17 | Swing lock switch            |
| 4 | Breaker operation switch | 11 | Fuse & relay box        | 18 | Fine swing switch            |
| 5 | Starting switch          | 12 | Master switch           | 19 | Emergency engine stop switch |
| 6 | Cluster                  | 13 | Cigar lighter           |    |                              |
| 7 | Service meter            | 14 | 12V socket              |    |                              |

## 2. LOCATION 2

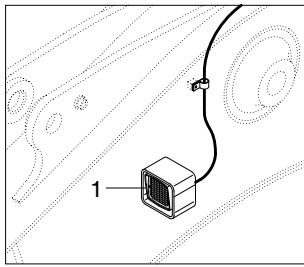

BOOM

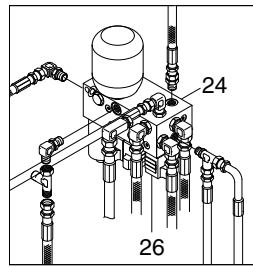

SOLENOID VALVE

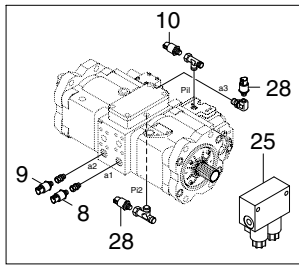

MAIN PUMP

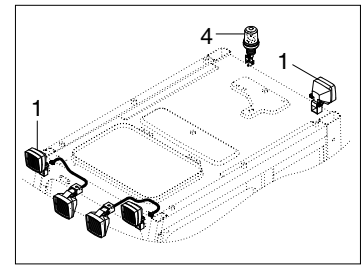

CAB

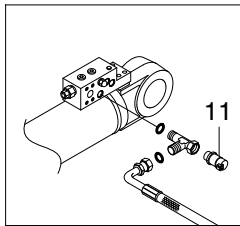

BOOM SAFETY VALVE

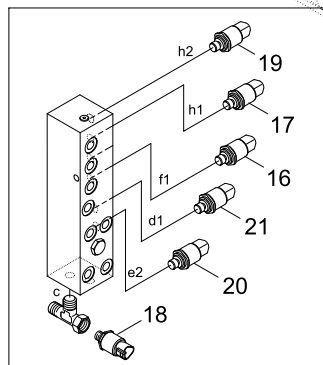
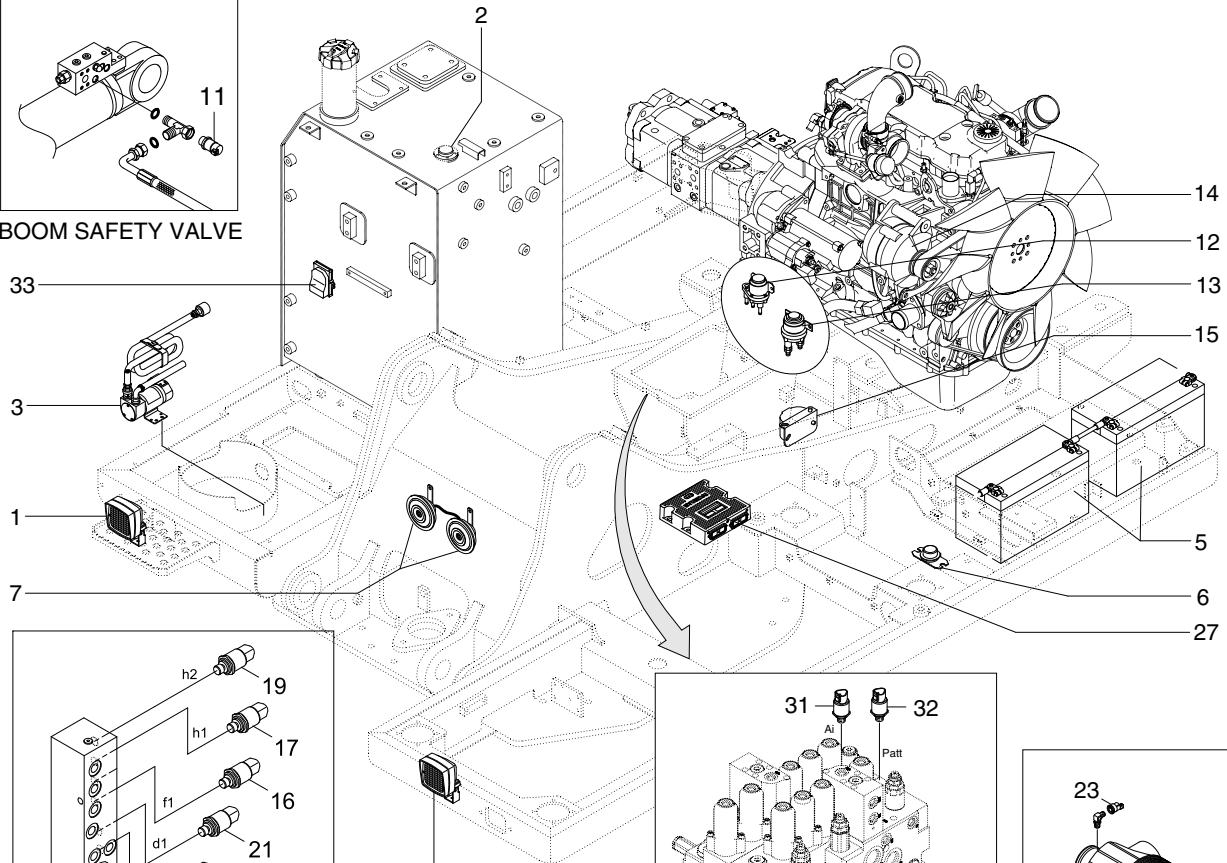

TERMINAL BLOCK

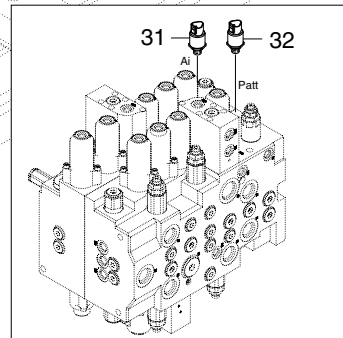

MAIN CONTROL VALVE

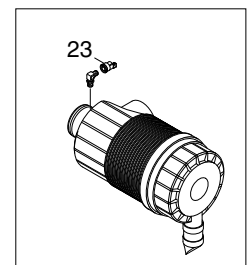

AIR CLEANER

140SA4EL02

- |                           |                              |                                 |
|---------------------------|------------------------------|---------------------------------|
| 1 Lamp                    | 11 Overload pressure sensor  | 21 Arm out pressure sensor      |
| 2 Fuel sender             | 12 Start relay               | 23 Air cleaner sensor           |
| 3 Fuel filler pump        | 13 Heater relay              | 24 Solenoid valve               |
| 4 Beacon lamp             | 14 Alternator                | 25 Pump flow control EPPR valve |
| 5 Battery                 | 15 Travel alarm buzzer       | 26 Boom priority EPPR valve     |
| 6 Battery relay           | 16 Bucket in pressure sensor | 27 MCU                          |
| 7 Horn                    | 17 Boom up pressure sensor   | 28 Nega-control pressure sensor |
| 8 A1 pump pressure sensor | 18 Swing pressure sensor     | 31 Travel pressure sensor       |
| 9 A2 pump pressure sensor | 19 Boom down pressure sensor | 32 Attach pressure sensor       |
| 10 EPPR pressure sensor   | 20 Arm in pressure sensor    | 33 RDU assy                     |

GROUP 2 ELECTRICAL CIRCUIT (1/2)

ELECTRICAL CIRCUIT (1/2)

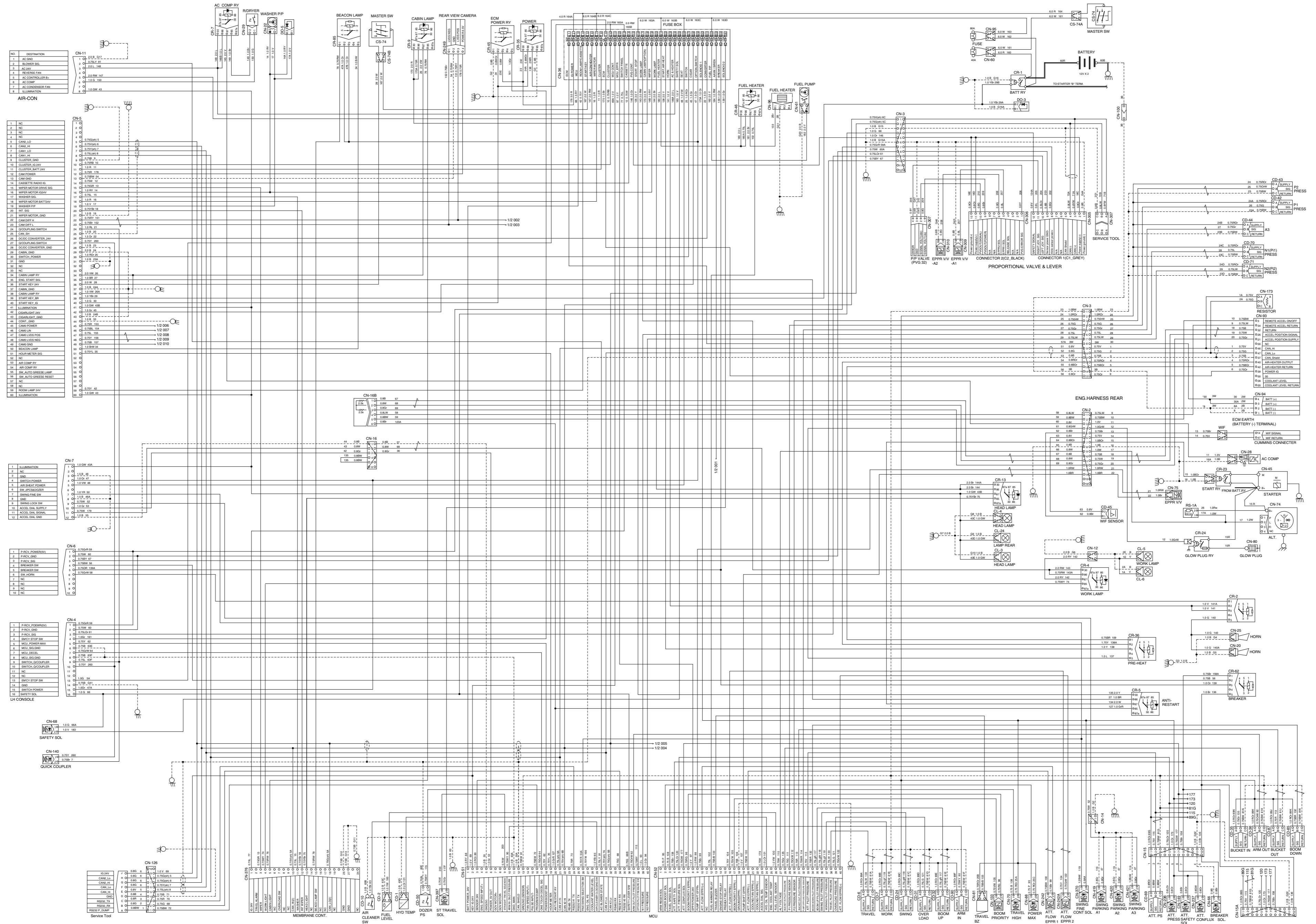

ELECTRICAL CIRCUIT (2/2)

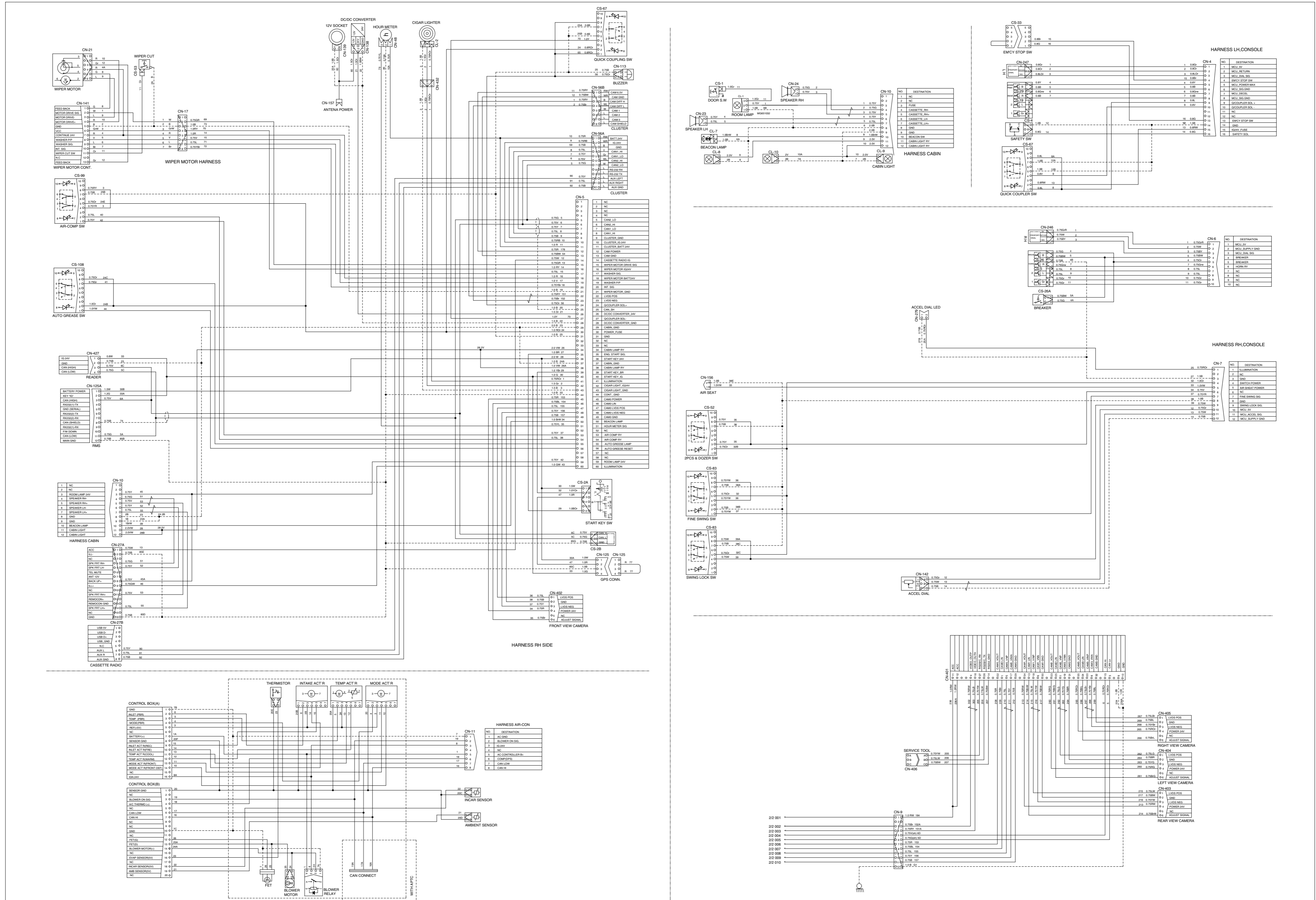

**MEMORANDUM**

## 1. POWER CIRCUIT

The negative terminal of battery is grounded to the machine chassis directly.

When the start switch is in the OFF position, the current flows from the positive battery terminal as shown below.

### 1) OPERATING FLOW

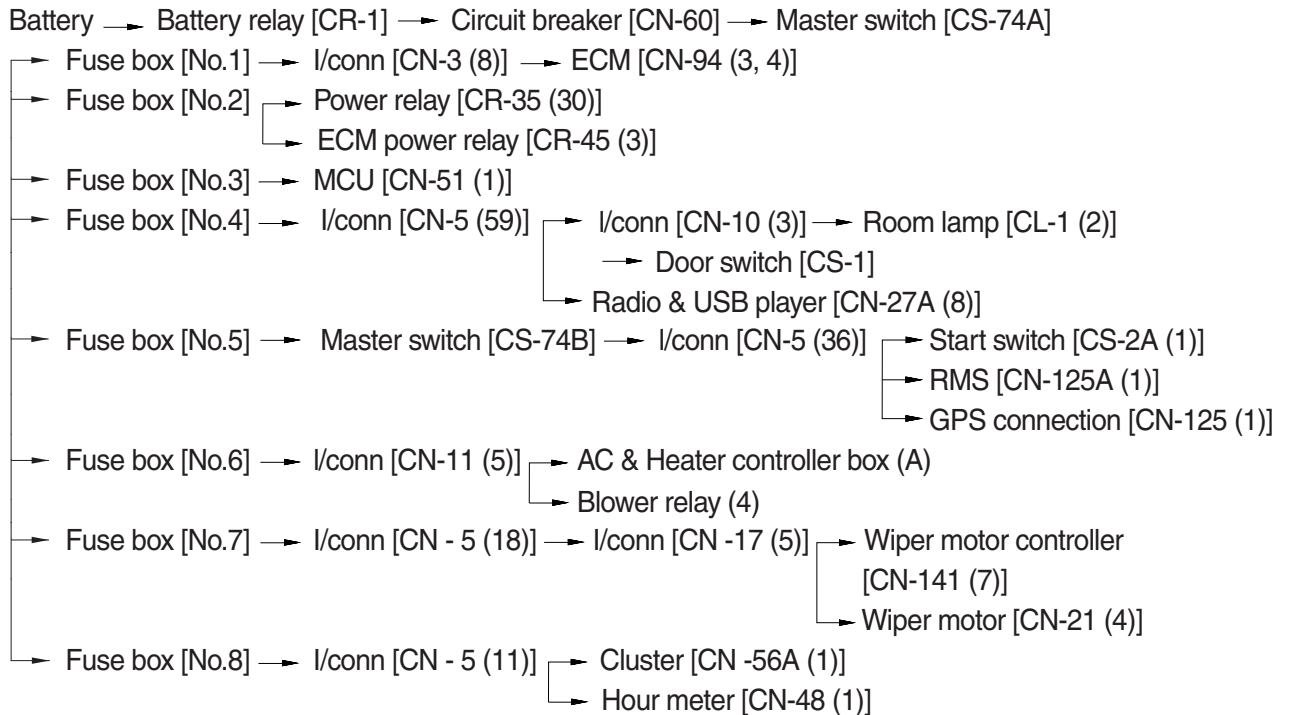

※ I/conn : Intermediate connector

### 2) CHECK POINT

Engine	Start switch	Check point	Voltage
STOP	OFF	① - GND (battery 1EA)	10~12.5V
		② - GND (battery 2EA)	20~25V
		③ - GND (battery relay)	20~25V
		④ - GND (fuse)	20~25V

※ GND : Ground

# POWER CIRCUIT

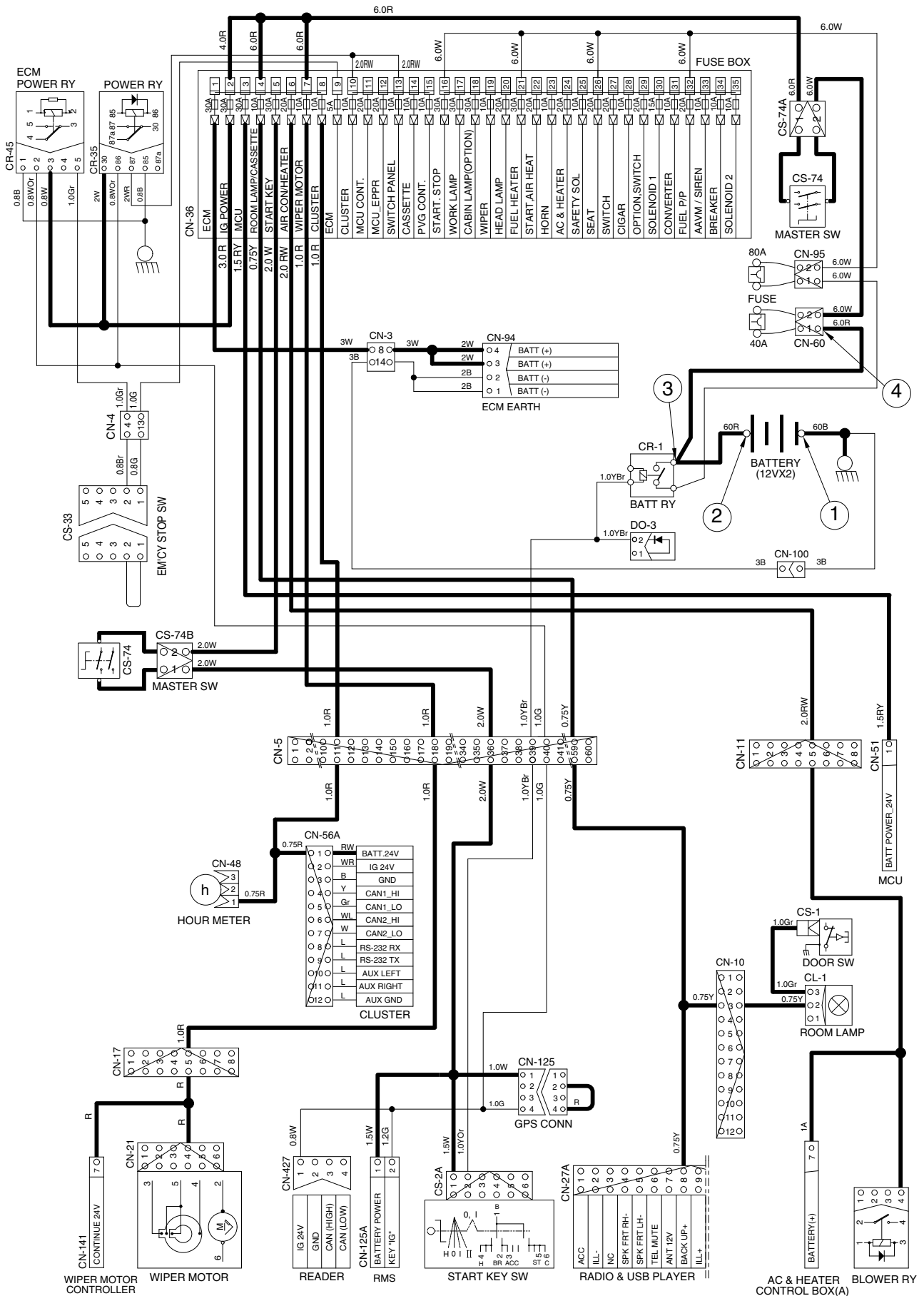

140SA4EL05



## 2. STARTING CIRCUIT

### 1) OPERATING FLOW

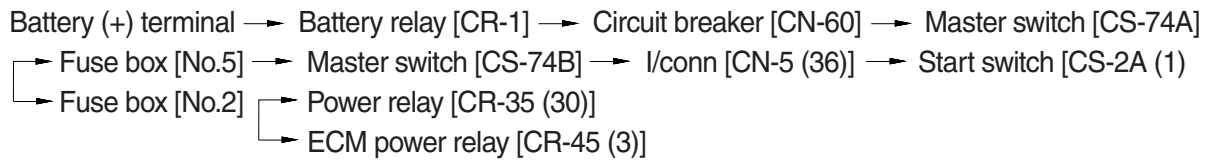

#### (1) When start switch is in ON position

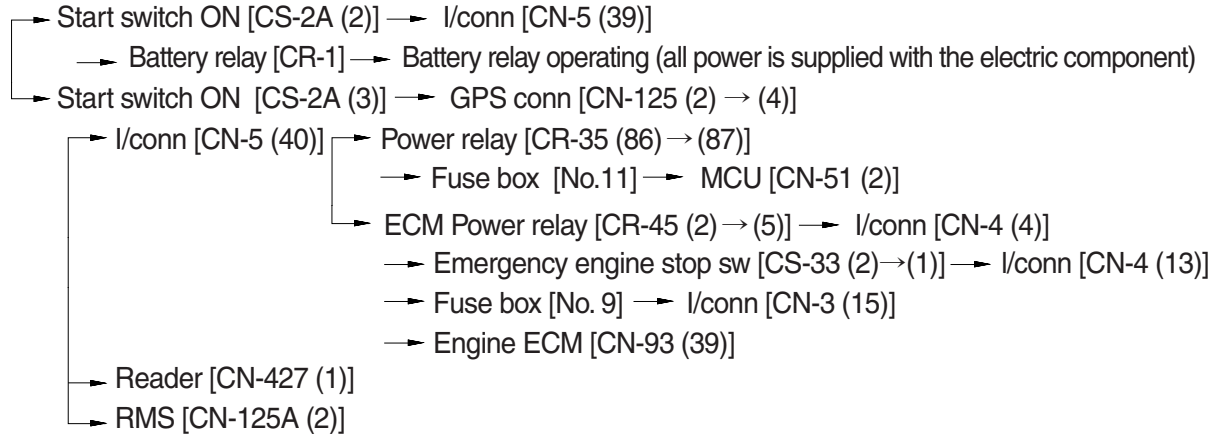

#### (2) When start switch is in START position

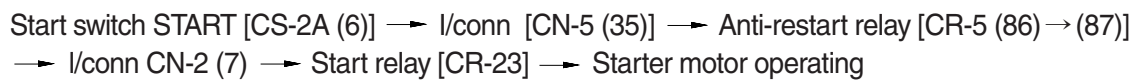

### 2) CHECK POINT

Engine	Start switch	Check point	Voltage
OPERATING	START	① - GND (battery) ② - GND (start switch) ③ - GND (battery relay M4) ④ - GND (starter B <sup>+</sup> ) ⑤ - GND (starter M) ⑥ - GND (start relay) ⑦ - GND (battery relay M8)	20~25V

# STARTING CIRCUIT

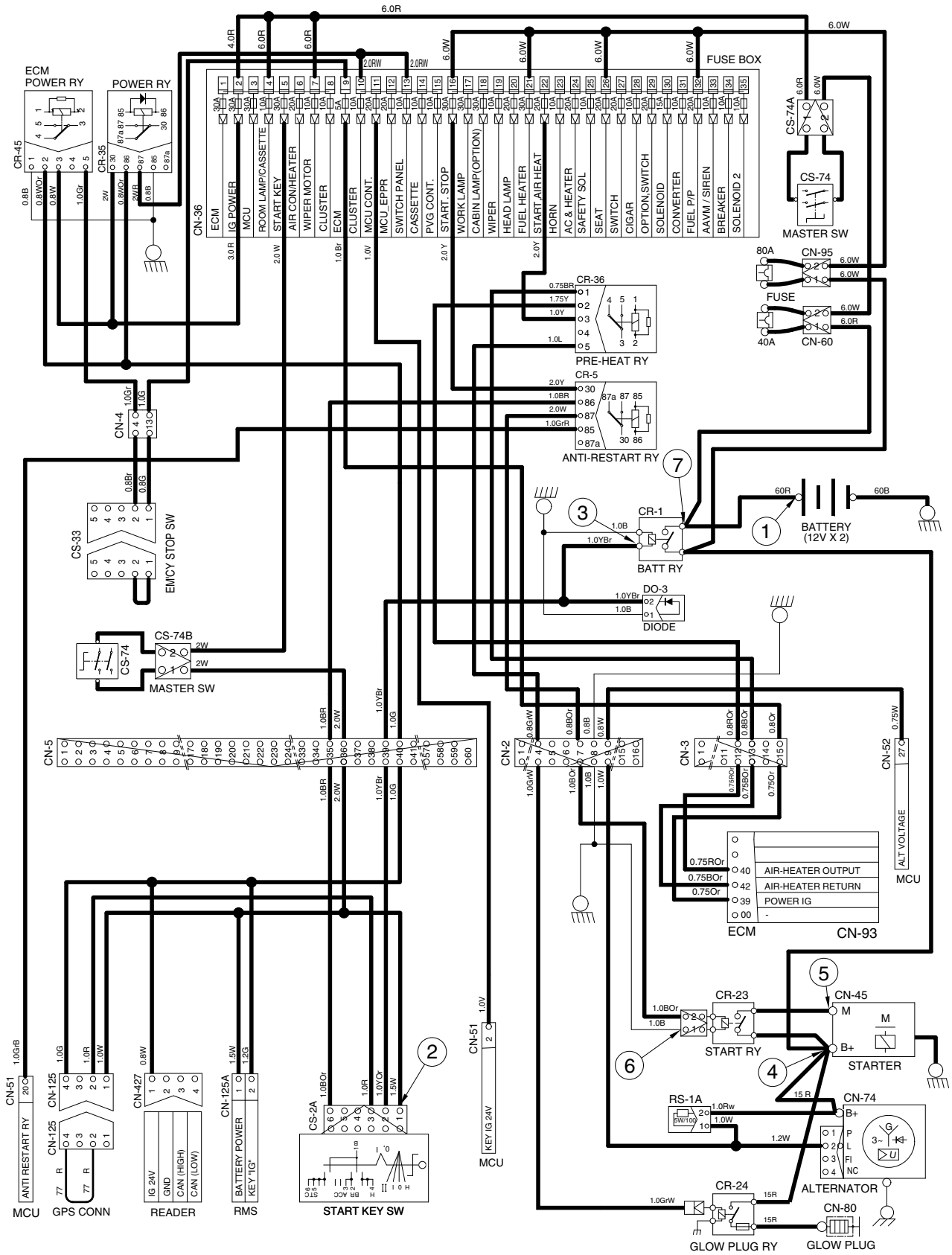

140SA4EL06

### 3. CHARGING CIRCUIT

When the starter is activated and the engine is started, the operator releases the start switch to the ON position.

Charging current generated by operating alternator flows into the battery through the battery relay [CR-1].

The current also flows from alternator to each electrical component and controller through the fuse box.

#### 1) OPERATING FLOW

##### (1) Warning flow

Alternator [CN-74 (2)] → I/conn [CN-2 (9)] → MCU alternator voltage [CN-52 (27)]  
 → Cluster charging warning lamp (Via CANbus interface)

##### (2) Charging flow

Alternator [CN-74 (B<sup>+</sup>)] → Start motor [CN-45 (B<sup>+</sup>)] → Battery relay (M8)  
 → Battery (+) terminal  
 → Fuse [CN-60] → Master switch [CS-74A] → Fuse box [No.1~8]  
 → Fuse [CN-95] → Fuse box [No.16~35]

#### 2) CHECK POINT

Engine	Start switch	Check point	Voltage
RUN	ON	① - GND (battery voltage) ② - GND (battery relay) ③ - GND (alternator B <sup>+</sup> terminal) ④ - GND (alternator 2 terminal) ⑤ - GND (MCU)	20~25V

※ GND : Ground

# CHARGING CIRCUIT

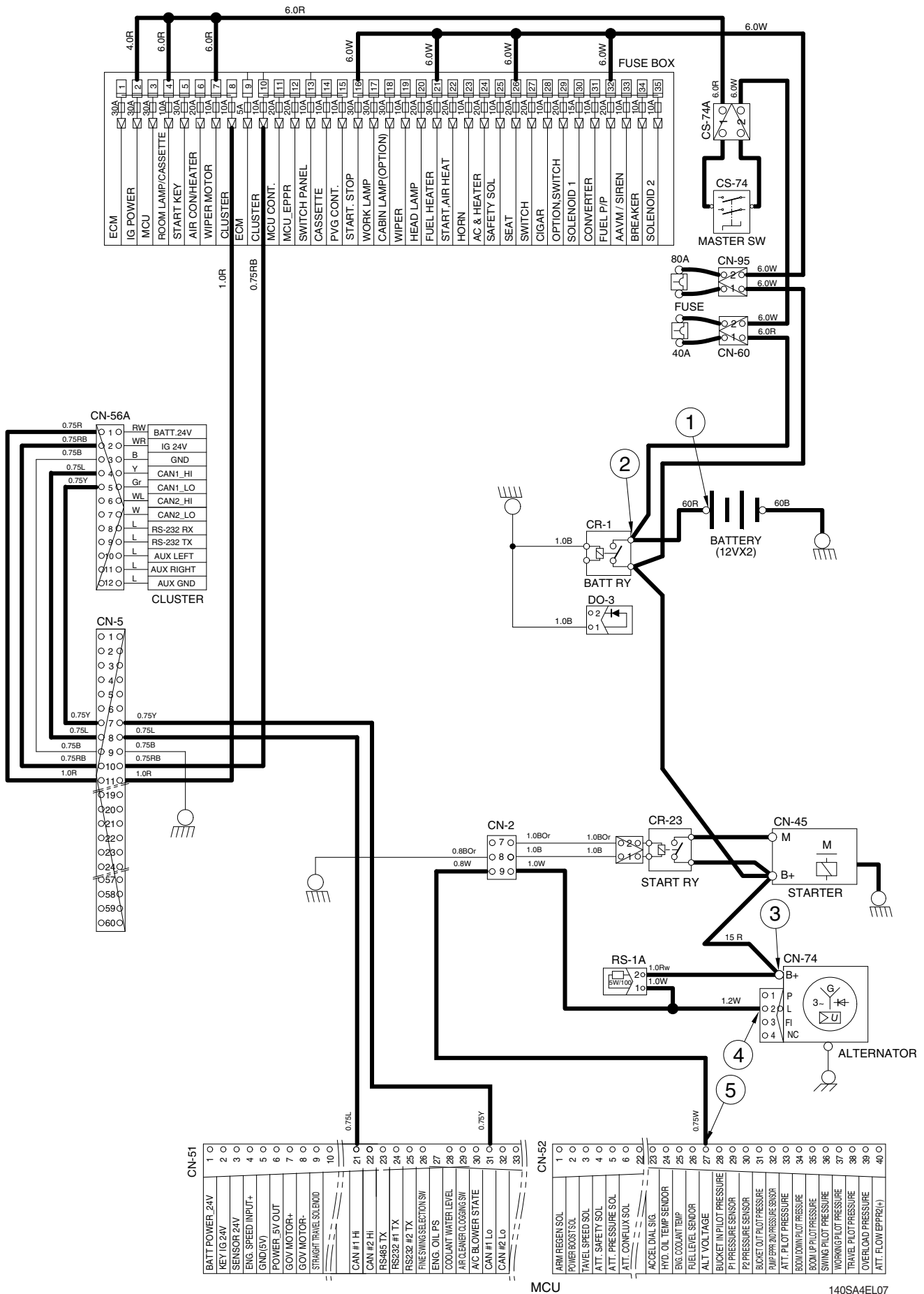

## 4. HEAD AND WORK LIGHT CIRCUIT

### 1) OPERATING FLOW

Fuse box (No.20) → Head light relay [CR-13 (30, 86)]

Fuse box (No.17) → Work light relay [CR-4 (30, 86)]

Fuse box (No.13) → Membrane controller [CN-376 (1)]

#### (1) Head light switch ON

Head light switch ON [CN-376 (13)] → Head light relay [CR-13 (85) → (87)]

→ Head light ON [CL-3 (2), CL-4 (1), CL-24 (2)]

→ I/conn [CN-5 (41)] → I/conn [CN-432 (1)] → Cigar lighter [CL-2]

→ I/conn [CN-5 (60)] → Radio & USB player illumination ON [CN-27A (9)]

→ I/conn [CN-7 (1)] → Accel dial LED [CN-279 (2)]

#### (2) Work light switch ON

Work light switch ON [CN-376 (4)] → Work light relay [CR-4 (85) → (87)]

→ I/conn [CN-12 (2)] → Work light ON [CL-5 (2), CL-6 (2)]

### 2) CHECK POINT

Engine	Start switch	Check point	Voltage
STOP	ON	① - GND (fuse box) ② - GND (switch power input) ③ - GND (head light relay) ④ - GND (head light) ⑤ - GND (fuse box) ⑥ - GND (switch power output) ⑦ - GND (work light relay) ⑧ - GND (work light)	20~25V

※ GND : Ground

# HEAD AND WORK LIGHT CIRCUIT

FUSE BOX

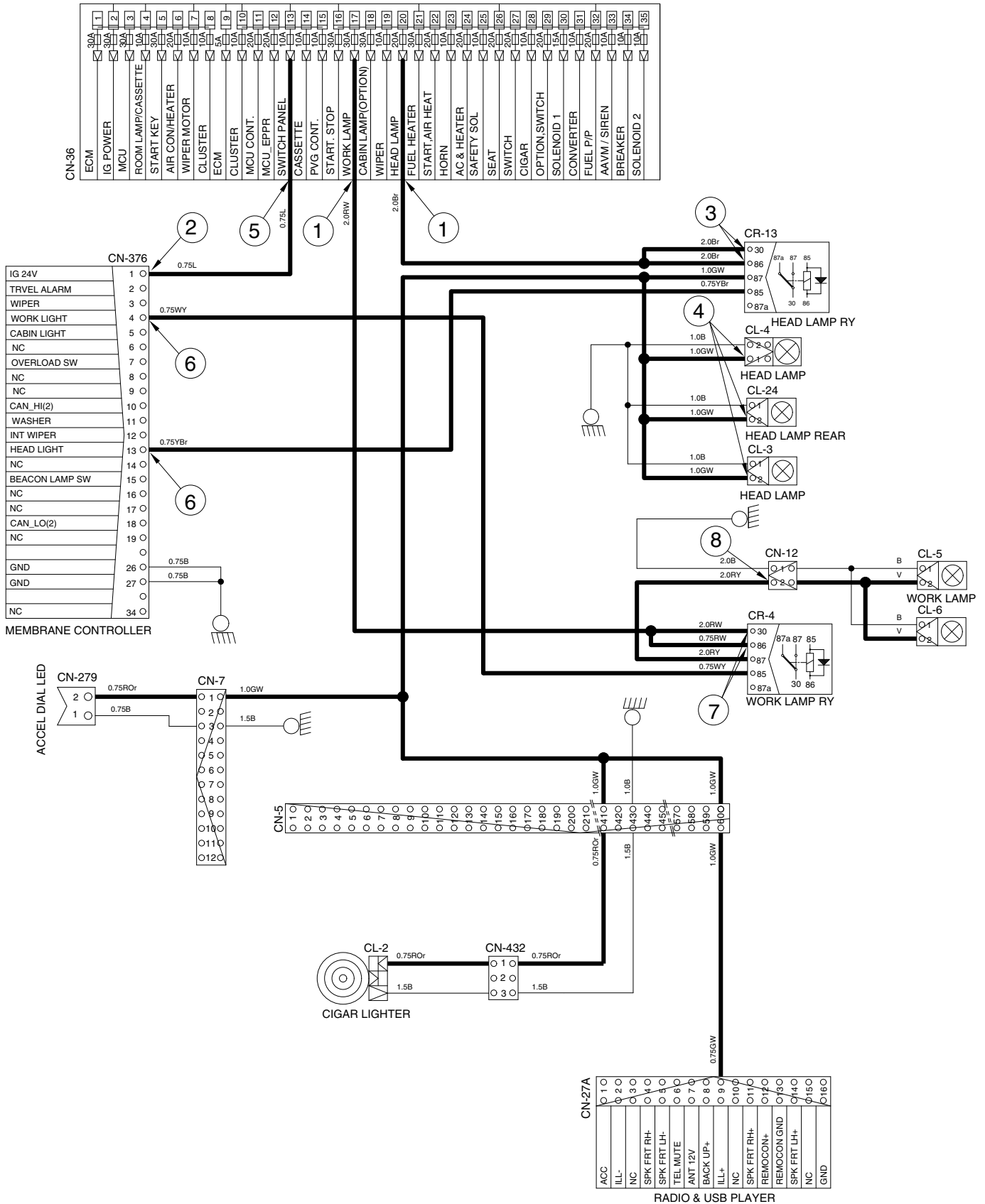

## 5. BEACON LAMP AND CAB LIGHT CIRCUIT

### 1) OPERATING FLOW

Fuse box (No.29) → Beacon lamp relay [CR-85 (2, 3)]

Fuse box (No.18) → Cab light relay [CR-9 (30, 86)]

Fuse box (No.13) → Membrane controller [CN-376 (1)]

#### (1) Beacon lamp switch ON

Beacon lamp switch ON [CN-376 (15)] → Beacon lamp relay [CR-85 (1)→ (5)]

→ I/conn [CN-5 (50)] → I/conn [CN-10 (10)] → Beacon lamp ON [CL-7]

#### (2) Cab light switch ON

Cab light switch ON [CN-376 (5)] → Cab lamp relay [CR-9 (85)→ (87)]

→ I/conn [CN-5 (34, 38)] → I/conn [CN-10 (11)] → Cab light ON [CL-8 (2)]

→ I/conn [CN-10 (12)] → Cab light ON [CL-9 (2), CL-10 (2)]

### 2) CHECK POINT

Engine	Start switch	Check point	Voltage
STOP	ON	① - GND (fuse box) ② - GND (beacon lamp relay) ③ - GND (switch power input) ④ - GND (beacon lamp) ⑤ - GND (fuse box) ⑥ - GND (cabin light relay) ⑦ - GND (switch power output) ⑧ - GND (cab light)	20~25V

※ GND : Ground

# BEACON LAMP AND CAB LIGHT CIRCUIT

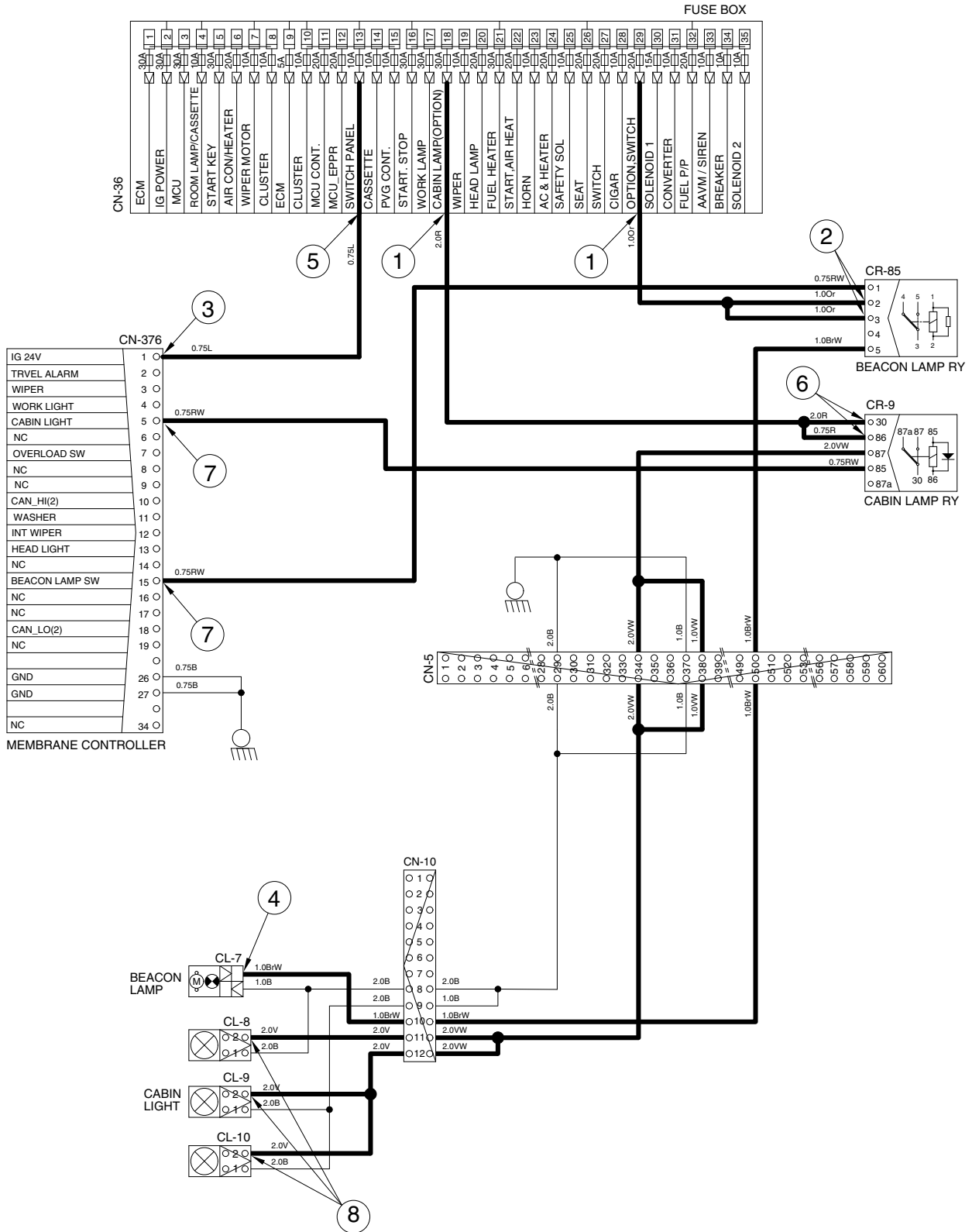



## 6. WIPER AND WASHER CIRCUIT

### 1) OPERATING FLOW

#### (1) Start switch ON

Fuse box (No.13) → Membrane controller [CN-376 (1)]

Fuse box (No.7) → I/conn [CN-5 (18)] → I/conn [CN-17 (5)] → Wiper motor controller [CN-141 (7)]  
 → Wiper motor [CN-21 (4)]

Fuse box (No.19) → I/conn [CN-5 (16)] → I/conn [CN-17 (4)] → Wiper motor controller [CN-141 (6)]  
 → Wiper pump [CN-22 (2)]

#### (2) Wiper switch ON (Intermittent)

Wiper switch ON [CN-376 (12)] → I/conn [CN-5 (20)] → I/conn [CN-17 (8)]

→ Wiper motor controller [CN-141 (10)→(3)] → Wiper motor [CN-21 (6)] → Intermittently operating

#### (3) Wiper switch ON (continual)

Wiper switch ON [CN-376 (3)] → I/conn [CN-5 (15)] → I/conn [CN-17 (2)]

→ Wiper motor controller [CN-141 (2) → (4)] → Wiper motor [CN-21 (2)] → Continual operating

#### (4) Washer switch ON

Washer switch ON [CN-376 (11)] → I/conn [CN-5 (17)] → I/conn [CN-17 (7)]

→ Wiper motor controller [CN-141 (9) → (8)] → I/conn [CN-17 (6)] → I/conn [CN-5 (19)]

→ Washer pump [CN-22 (1)] → Washer operating

Wiper switch ON [CN-376 (3)] → I/conn [CN-5 (15)] → I/conn [CN-17 (2)]

→ Wiper motor controller [CN-141 (2) → (4)] → Wiper motor [CN-21 (2)] → Continual operating

#### (5) Auto parking (when switch OFF)

Switch OFF [CN-376 (3)] → Wiper motor parking position by wiper motor controller

### 3) CHECK POINT

Engine	Start switch	Check point	Voltage
STOP	ON	① - GND (fuse box)	20~25V
		② - GND (switch power input)	
		③ - GND (switch power output)	0 ~ 5V
		④ - GND (wiper switch power input)	
		⑤ - GND (wiper power output)	24V
		⑥ - GND (wiper motor)	0 or 24V

※ GND : Ground

# WIPER AND WASHER CIRCUIT

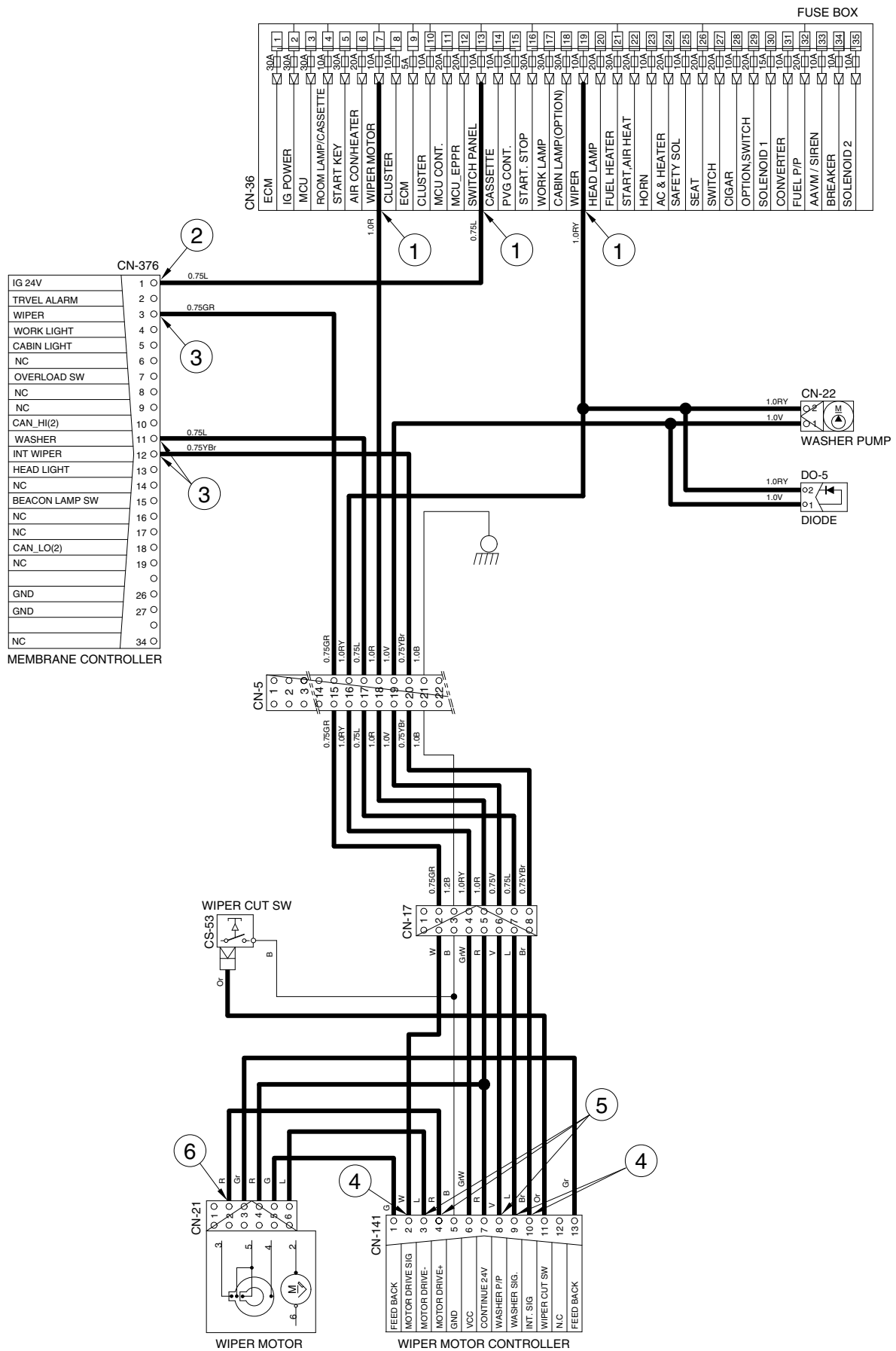

140SA4EL10

# CONTROLLER CIRCUIT

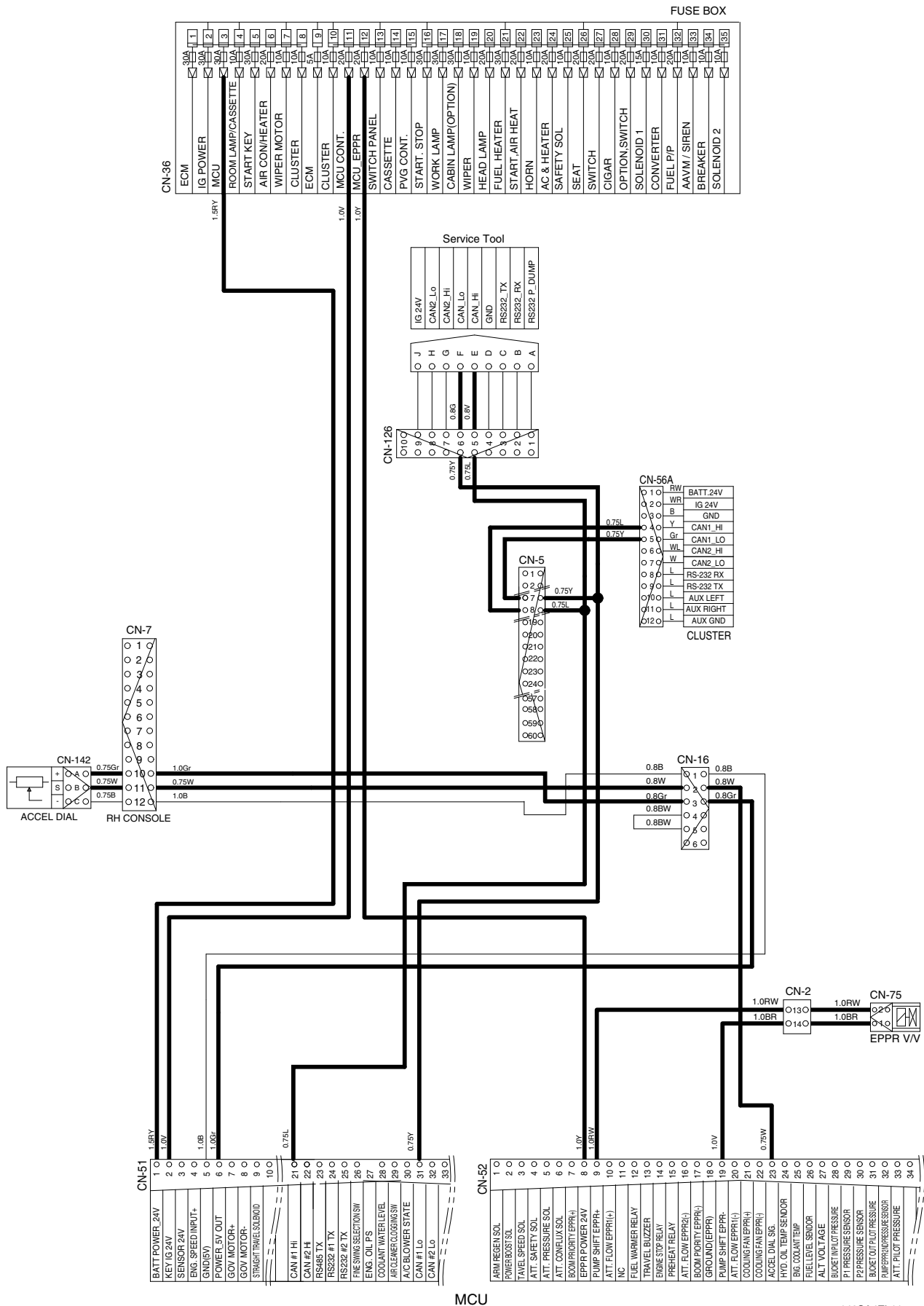

# MONITORING CIRCUIT

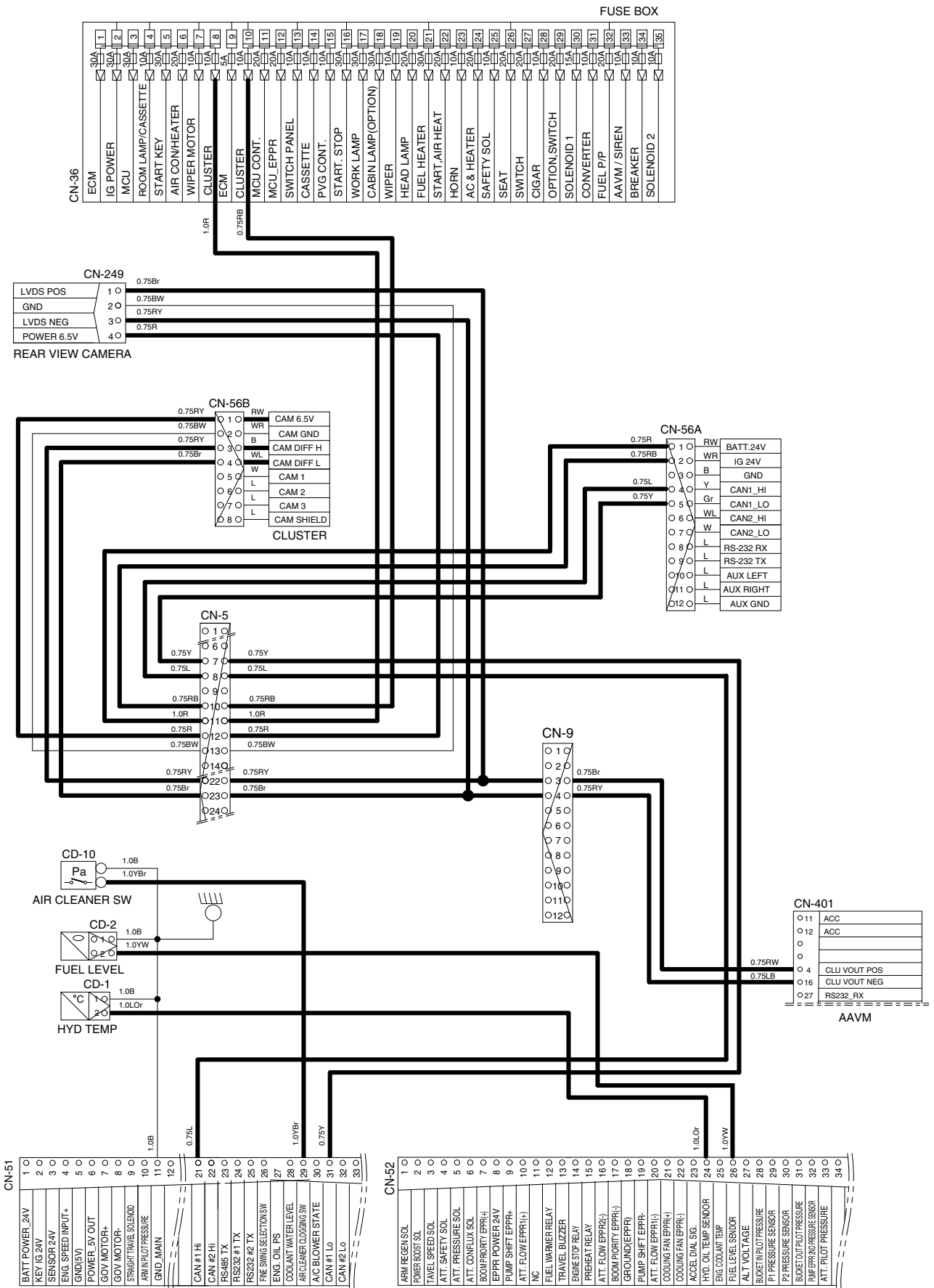

MCU

140SA4EL12

# ELECTRIC CIRCUIT FOR HYDRAULIC (1/2)

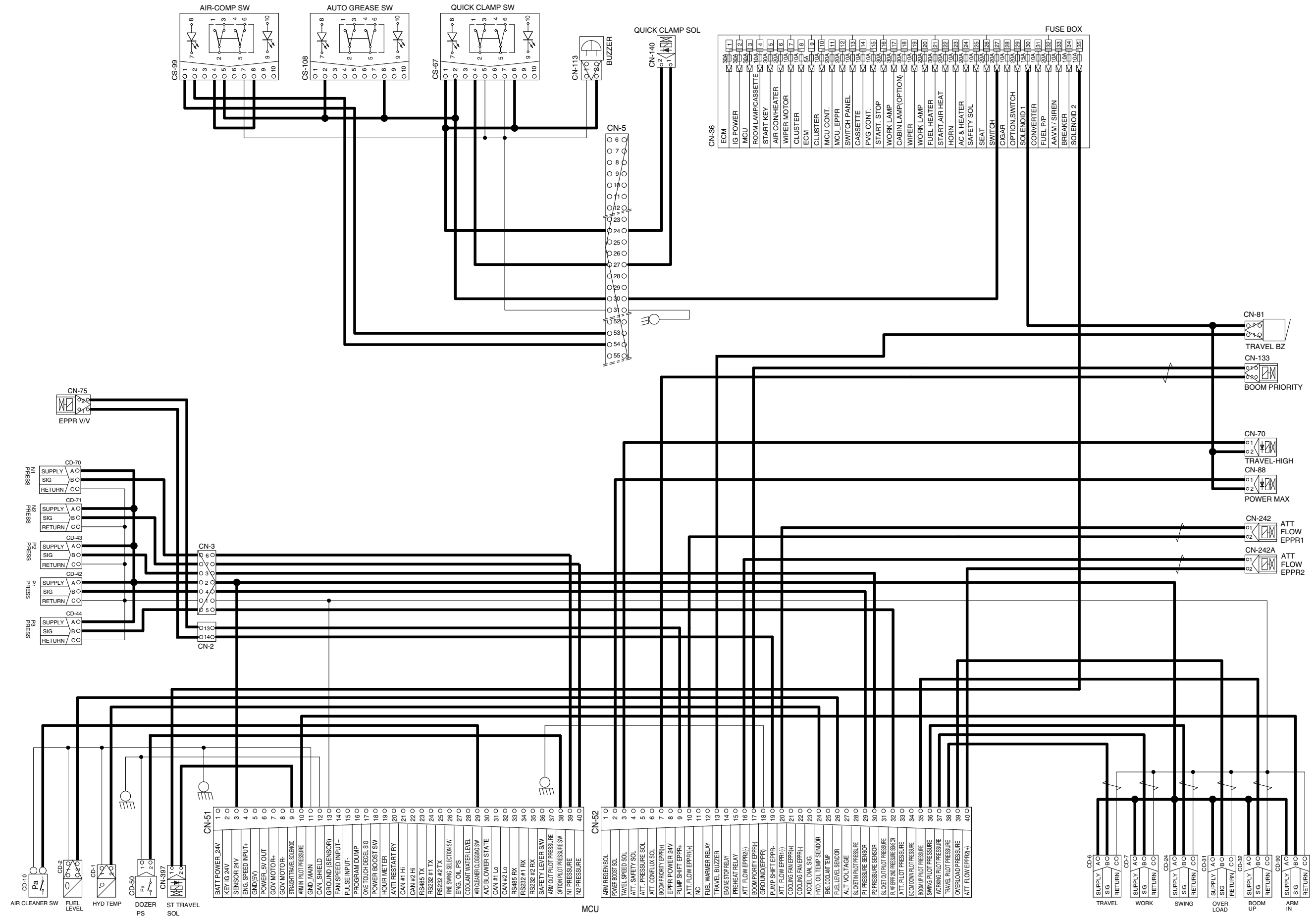

# ELECTRIC CIRCUIT FOR HYDRAULIC (2/2)

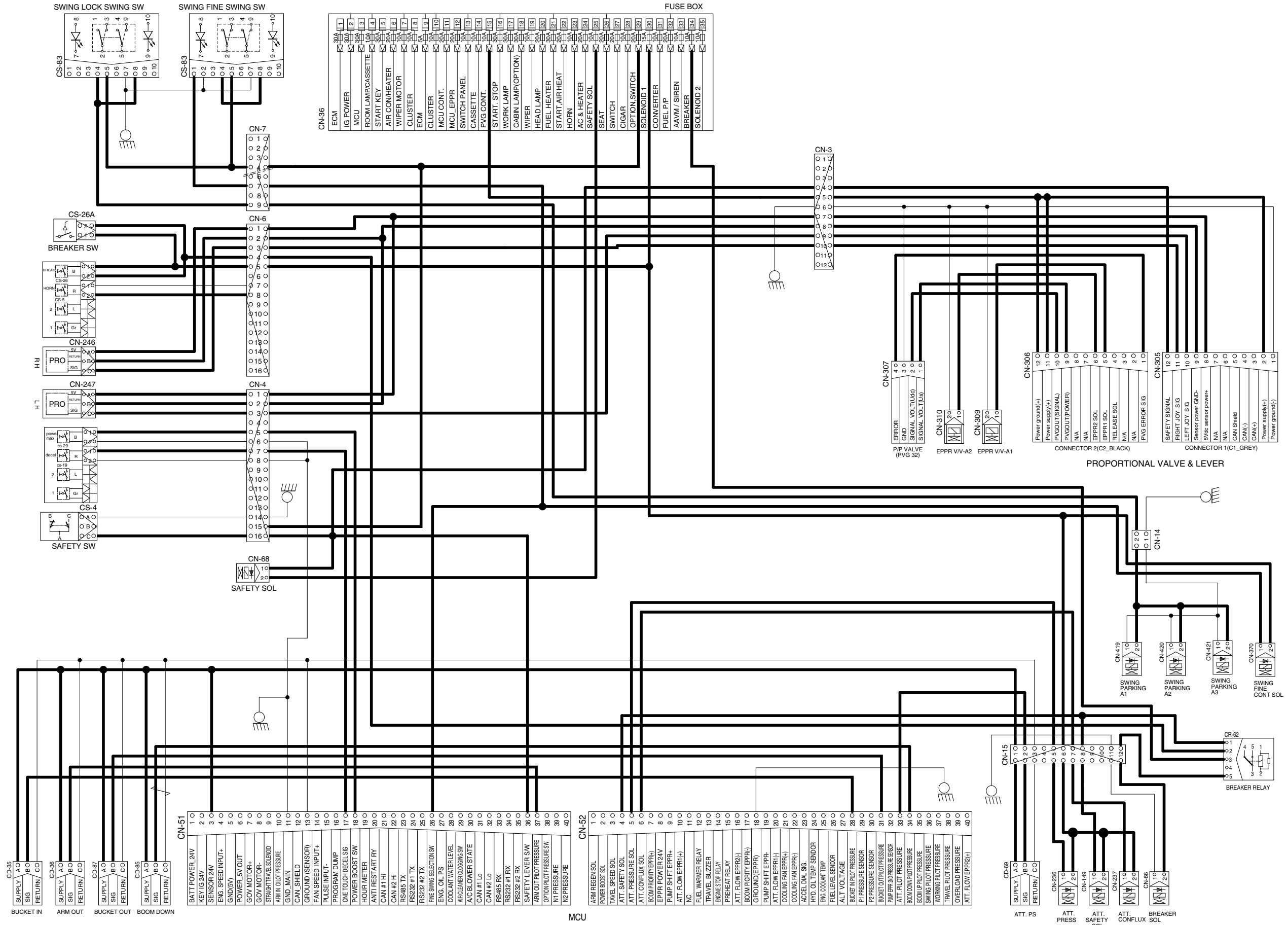

## GROUP 3 ELECTRICAL COMPONENT SPECIFICATION

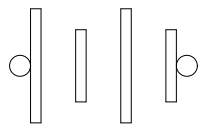
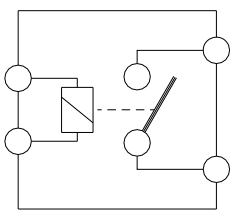
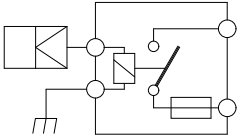
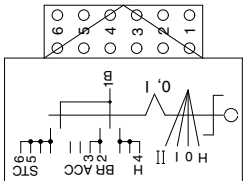
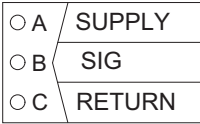
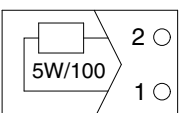
Part name	Symbol	Specifications	Check
Battery		12V × 100Ah (2EA)	※ Check specific gravity 1.280 over : Over charged 1.280 ~ 1.250 : Normal 1.250 below : Recharging
Battery relay	 <p style="text-align: center;">CR-1</p>	Rated load : 24V 100A (continuity) 1000A (30seconds)	※ Check coil resistance(M4 to M4) Normal : About 50Ω ※ Check contact Normal : ∞Ω
Glow plug relay	 <p style="text-align: center;">CR-24</p>	24V 200A	※ Check contact Normal : 0.942Ω (For terminal 1-GND)
Start switch	 <p style="text-align: center;">CS-2A</p>	B-BR : 24V 1A B-ACC : 24V 10A B-ST : 24V 40A	※ Check contact OFF : ∞Ω (for each terminal) ON : 0Ω (for terminal 1-3 and 1-2) START : 0Ω (for terminal 1-6)
Pressure sensor	 <p style="text-align: center;">                     CD-6 CD-7 CD-24 CD-31                      CD-32 CD-35 CD-36 CD-42                      CD-43 CD-44 CD-69 CD-70                      CD-71 CD-85 CD-87 CD-90                 </p>	8~30V	※ Check contact Normal : 0.1Ω
Resistor	 <p style="text-align: center;">RS-1A</p>	5W 100Ω	※ Check resistance Normal : 100Ω (For terminal 1-2)

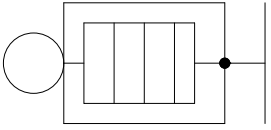
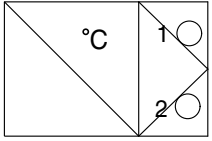
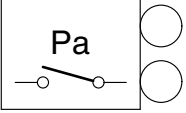
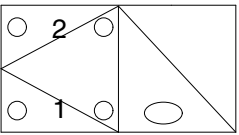
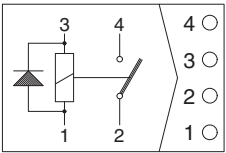
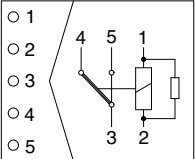
Part name	Symbol	Specifications	Check
Glow plug	 CN-80	24V 200A	※ Check resistance 0.25~0.12Ω
Temperature sensor (hydraulic)	 CD-1	-	※ Check resistance 50°C : 804Ω 80°C : 310Ω 100°C : 180Ω
Air cleaner pressure switch	 CD-10	N.O TYPE	※ Check contact High level : ∞Ω Low level : 0Ω
Fuel level sender	 CD-2	-	※ Check resistance Full : 50Ω      6/12 : 350Ω 11/12 : 100Ω    5/12 : 400Ω 10/12 : 150Ω    4/12 : 450Ω 9/12 : 200Ω     3/12 : 500Ω 8/12 : 250Ω     2/12 : 550Ω 7/12 : 300Ω     1/12 : 600Ω Empty warning : 700Ω
Relay (air con blower)		24V 20A	※ Check resistance Normal : About 200Ω (for terminal 1-3) ∞Ω (for terminal 2-4)
Relay	 CR-2 CR-36 CR-45 CR-62 CR-85	24V 16A	※ Check resistance Normal : About 160Ω (for terminal 1-2) 0Ω (for terminal 3-4) ∞Ω (for terminal 3-5)

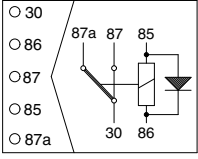
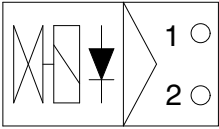
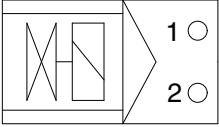
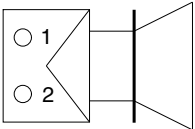
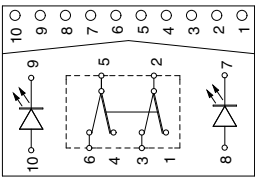
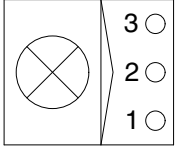

Part name	Symbol	Specifications	Check
Relay	 <p>CR-4 CR-5 CR-7 CR-9 CR-13 CR-35 CR-46</p>	24V 16A	※ Check resistance Normal : About 160 Ω (for terminal 85-86) 0 Ω (for terminal 30-87a) ∞ Ω (for terminal 30-87)
Solenoid valve	 <p>CN-66 CN-68 CN-70 CN-88 CN-140 CN-149 CN-236 CN-237 CN-370 CN-397 CN-419 CN-420 CN-421</p>	24V 1A	※ Check resistance Normal : 15~25 Ω (for terminal 1-2)
EPPR valve	 <p>CN-75 CN-133 CN-242 CN-242A CN-309 CN-310</p>	700mA	※ Check resistance Normal : 15~25 Ω (for terminal 1-2)
Speaker	 <p>CN-23 (LH) CN-24 (RH)</p>	20W	※ Check resistance Normal : A few Ω
Switch (locking type)	 <p>CS-52 CS-67 CS-83 CS-99 CS-108</p>	24V 8A	※ Check contact Normal OFF : ∞ Ω (for terminal 2-3, 5-6) 0 Ω (for terminal 1-2, 4-5)
Room lamp	 <p>CL-1</p>	24V 10W	※ Check disconnection Normal : 1.0 Ω OFF : ∞ Ω (For terminal 1-2) 0 Ω (For terminal 1-3)

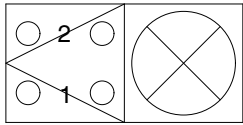
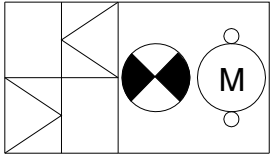
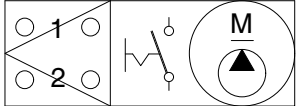
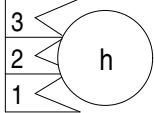
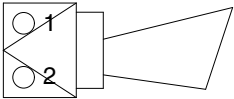
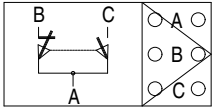
Part name	Symbol	Specifications	Check
Head lamp, Work lamp, Cab lamp	 CL-3 CL-4 CL-5 CL-6 CL-8 CL-9 CL-10 CL-24	24V 65W (H3 Type)	※ Check disconnection Normal : 1.2Ω
Beacon lamp	 CL-7	21V 70W (H1 Type)	※ Check disconnection Normal : A few Ω
Fuel filler pump	 CN-61	24V 10A 35 l /min	※ Check resistance Normal : 1.0Ω
Hour meter	 CN-48	16~32V	※ Check operation Supply power (24V) to terminal No.2 and connect terminal No.1 and ground
Horn	 CN-20 CN-25	DC22~28V 2A	※ Check operation Supply power (24V) to each terminal and connect ground.
Safety switch	 CS-4	24V 15A (N.C TYPE)	※ Check contact Normal : 0Ω (for terminal A-B) ∞ Ω (for terminal A-C) Operating : ∞ Ω (for terminal A-B) 0 Ω (for terminal A-C)

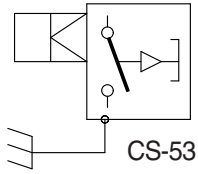
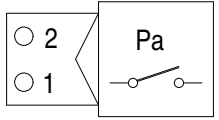
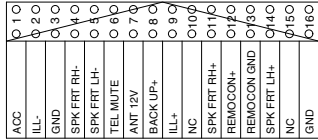
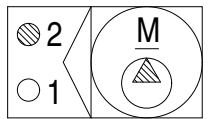
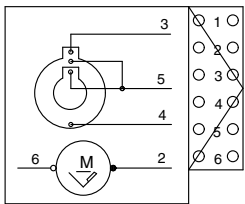
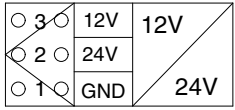
Part name	Symbol	Specifications	Check
Wiper cut switch	 <p>CS-53</p>	24V (N.O TYPE)	※ Check contact Normal : 0Ω (one pin to ground)
Receiver dryer	 <p>CN-29</p>	24V 2.5A	※ Check contact Normal : ∞Ω
Radio & USB player	 <p>CN-27A</p>	24V 2A	※ Check voltage 20~25V (for terminal 1-3, 3-8)
Washer pump	 <p>CN-22</p>	24V 3.8A	※ Check contact Normal : 10.7Ω (for terminal 1-2)
Wiper motor	 <p>CN-21</p>	24V 2A	※ Check disconnection Normal : 7Ω (for terminal 2-6)
DC/DC Converter	 <p>CN-138</p>	12V 3A	※ Check voltage 24V (for terminal 1-2) 12V (for terminal 1-3)

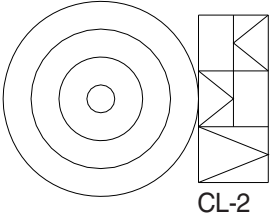
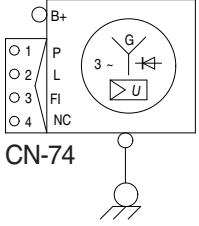
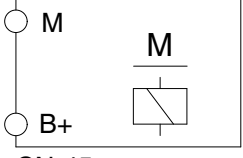
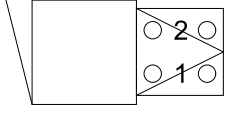
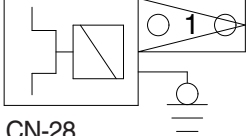
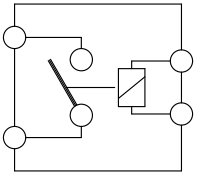
Part name	Symbol	Specifications	Check
Cigar lighter	 <p>CL-2</p>	24V 5A 1.4W	※ Check coil resistance Normal : About 1MΩ ※ Check contact Normal : ∞Ω Operating time : 5~15sec
Alternator	 <p>CN-74</p>	Denso 24V 70A	※ Check contact Normal : 0Ω (for terminal B <sup>+</sup> -2) Normal : 24~27.5V
Starter	 <p>CN-45</p>	24V 4.8kW	※ Check contact Normal : 0.1Ω
Travel alarm	 <p>CN-81</p>	24V 0.5A	※ Check contact Normal : 5.2Ω
Aircon compressor	 <p>CN-28</p>	24V 79W	※ Check contact Normal : 13.4Ω
Start relay	 <p>CR-23</p>	24V 300A	※ Check contact Normal : 0.94Ω (for terminal 1-2)

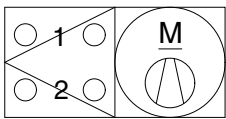
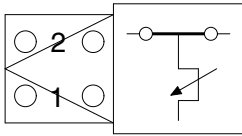
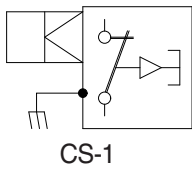
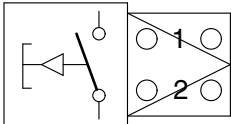
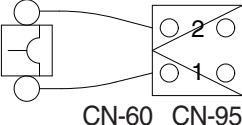
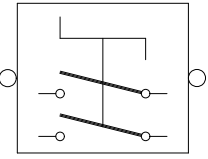
Part name	Symbol	Specifications	Check
Blower motor		24V 9.5A	※ Check resistance Normal : 2.5Ω (for terminal 1-2)
Thermistor		1°C OFF 4°C ON	※ Check resistance Normal : 0Ω (for terminal 1-2), the atmosphere temp : Over 4°C
Door switch	 <p>CS-1</p>	24V 2W	※ Check resistance Normal : About 5MΩ
Switch (power max, one touch decel, horn, breaker)	 <p>CS-5 CS-19 CS-26 CS-29</p>	24V 6A	※ Check resistance Normal : ∞Ω
Fuse	 <p>CN-60 CN-95</p>	CN-60 : 40A CN-95 : 80A	※ Check disconnection Normal : 0Ω (connect ring terminal and check resist between terminal 1 and 2)
Master switch	 <p>CS-74</p>	6-36V	※ Check disconnection Normal : 0.1Ω

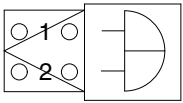
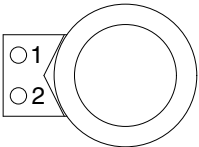
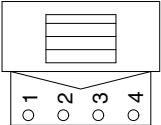
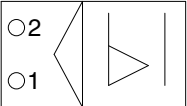
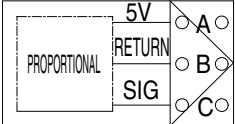
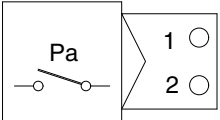
Part name	Symbol	Specifications	Check
Quick clamp buzzer	 <p>CN-113</p>	24V 200mA 107 ± 4dB	-
Socket	 <p>CN-139</p>	12V 10A	-
Fuel heater	 <p>CN-96</p>	-	-
WIF sensor	 <p>CD-45</p>	-	-
Proportional valve sensor	 <p>CN-246    CN-247</p>	-	-
Dozer pressure switch		-	-

## GROUP 4 CONNECTORS

### 1. CONNECTOR DESTINATION

Connector number	Type	No. of pin	Destination	Connector part No.	
				Female	Male
CN-2	AMP	16	I/conn (Frame harness-Engine harness)	368047-1	368050-1
CN-3	TE/AMP	15	I/conn (Frame harness-Pro vlv harness)	2-85262-1	368537-1
CN-4	AMP/TE	16	I/conn (Console harness LH-Frame harness)	368047-1	368050-1
CN-5	DEUTSCH	60	I/conn (Side harness RH-Frame harness)	DRB16-60SAE-L018	DRB14-60PAE-L018
CN-6	AMP/TE	10	I/conn (Console harness RH-Frame harness)	S816-010002	174657-2
CN-7	AMP/TE	12	I/conn (Console harness RH-Frame harness)	S816-012002	174663-2
CN-9	DEUTSCH	12	I/conn (Frame harness-AAVM harness)	DT06-12SA-EP06	DT04-12PA-P021
CN-10	DEUTSCH	12	I/conn (Cab harness-Side harness RH)	DT06-12S-EP06	DT04-12PA-P021
CN-11	DEUTSCH	8	I/conn (Frame harness-Aircon harness)	DT06-8S-EP06	-
CN-12	DEUTSCH	2	I/conn (Frame harness-Boom wire harness)	DT06-2S-EP06	DT04-2P-E005
CN-14	DEUTSCH	2	I/conn (Frame harness-Swing parking & fine control)	DT06-2S-EP06	DT04-2P-E005
CN-15	TE/AMP	12	I/conn (Frame harness-Breaker harness)	174661-2	368537-1
CN-16	TYCO	6	Emergency engine start & speed control	S816-006002	S816-106001
CN-16B	TYCO	6	Emergency engine start & speed control	S816-006002	21NB-10710
CN-17	AMP	8	I/conn (Wiper harness-Side harness RH)	S816-008002	S816-108002
CN-20	DEUTSCH	2	Horn	DT06-2S-EP06	-
CN-21	AMP	6	Wiper motor	S810-006202	-
CN-22	KET	2	Washer tank 1	MG640605	-
CN-23	KET	2	Speaker-LH	MG610070	-
CN-24	KET	2	Speaker-RH	MG610070	-
CN-25	DEUTSCH	2	Horn	DT06-2S-EP06	-
CN-27A	KUM	16	Radio & USB player	PK145-16017	-
CN-27B	AMP	8	Radio & USB player	-	174984-2
CN-28	KET	2	Aircon compressor	MG610320	-
CN-29	KET	2	Receiver dryer	MG640795	-
CN-36	-	-	Fuse & relay box	21Q7-10910	-
CN-45	RING-TERM	-	Starter motor B+	S820-108000	-
CN-48	KET	1	Hour meter	2-520193-2	-
CN-51	DEUTSCH	40	MCU	DRC26-40SA	-
CN-52	DEUTSCH	40	MCU	DRC26-40SB	-
CN-56A	AMP	12	Cluster	-	174663-2
CN-56B	AMP	8	Cluster	-	174984-2
CN-60	-	-	Fuse	-	-
CN-61	DEUTSCH	2	Fuel filler pump	DT06-2S-EP06	DT04-2P-E005
CN-66	DEUTSCH	2	Breaker solenoid	DT06-2S-EP06	-
CN-68	DEUTSCH	2	Safety solenoid	DT06-2S-EP06	-

Connector number	Type	No. of pin	Destination	Connector part No.	
				Female	Male
CN-70	DEUTSCH	2	Travel high solenoid	DT06-2S-EP06	-
CN-74	-	4	Alternator terminal	1218 6568	-
CN-75	AMP	2	Pump EPPR	S816-002002	-
CN-80	RING-TERM	-	Glow plug	S820-306000	-
CN-81	DEUTSCH	2	Travel buzzer solenoid	DT06-2S-EP06	DT04-2P-E005
CN-88	DEUTSCH	2	Power max solenoid	DT06-2S-EP06	-
CN-93	DEUTSCH	50	ECM	DRC26-50S-04	-
CN-94	DEUTSCH	4	ECM earth	DTP06-4S-EP06	-
CN-95	-	-	Fuse	-	-
CN-96	AMP	4	Fuel warmer	2-967325-1	2-967402-2
CN-96A	AMP	3	Fuel warmer	368523-1	-
CN-96B	AMP	4	Fuel warmer	2-967325-2	-
CN-100	KET	1	ECM ground	MG640944-5	-
CN-113	KET	2	Buzzer	MG651205-5	-
CN-125	Econoseal J	4	RMS connector	S816-004002	S816-104002
CN-125A	DEUTSCH	12	RMS	DT06-12S-P021	DT04-12PA-P021
CN-126	TE	10	Service tool	S816-010002	S816-110002
CN-133	DEUTSCH	2	Boom priority solenoid	DT06-2S-EP06	-
CN-138	FASTEN	3	DC/DC Converter	S810-003202	-
CN-139	FASTEN	2	12V socket	172434-2	-
CN-140	DEUTSCH	2	Quick clamp solenoid	DT06-2S-EP06	DT04-2P-E005
CN-141	AMP	13	Wiper motor controller	172498-1	-
CN-149	DEUTSCH	2	Attach safety solenoid	DT06-2S-EP06	-
CN-156	DEUTSCH	2	Air seat	DT06-2S-EP06	DT04-2P
CN-157	AMP	1	Antena power	S822-014002	-
CN-173	DEUTSCH	3	Resistor	DT06-3S-EP06	DT04-3P-EP10
CN-236	DEUTSCH	2	Attach pressure solenoid	DT06-2S-EP06	-
CN-237	DEUTSCH	2	Attach confluent solenoid	DT06-2S-EP06	-
CN-242	DEUTSCH	2	Attach EPPR 1 (A1)	DT06-2S-EP06	DT04-2P-E0005
CN-242A	DEUTSCH	2	Attach EPPR 2 (A2)	DT06-2S-EP06	DT04-2P-E0005
CN-246	DEUTSCH	3	Proportional valve-RH	DT06-3S	DT04-3P
CN-247	DEUTSCH	3	Proportional valve-LH	DT06-3S	DT04-3P
CN-249	DEUTSCH	4	Rear view camera	DT06-4S-EP06	DT04-4P-E005
CN-279	AMP	2	Accel dial LED	S816-002002	-
CN-305	DEUTSCH	12	Proportional-Connector 1	DTM06-12SA	-
CN-306	DEUTSCH	12	Proportional-Connector 2	DTM06-12SB	-
CN-307	DEUTSCH	3	Proportional-Service tool	DT06-3S-EP06	DT04-3P-E005
CN-307	AMP	4	Proportional-PVG32	2-967059-1	-
CN-309	DEUTSCH	2	Proportional-EPPR valve A2	DT06-2S-EP06	-



Connector number	Type	No. of pin	Destination	Connector part No.	
				Female	Male
CN-310	DEUTSCH	2	Proportional-EPPR valve A1	DT06-2S-EP06	-
CN-370	DEUTSCH	2	Swing fine control solenoid	DT06-2S-EP06	DT04-2P-E005
CN-376	TE	34	Membrane controller	4-1437290-1	-
CN-397	DEUTSCH	2	Straight travel solenoid	DT06-2S-EP06	DT04-2P-E005
CN-401	TE	35	AAVM controller	776164-1	-
CN-402	DEUTSCH	6	Front view camera	DT06-6S-P021	DT04-6P-P021
CN-403	DEUTSCH	6	Rear view camera	DT06-6S-EP06	DT04-6P-EP14
CN-404	DEUTSCH	6	LH view camera	DT06-6S-EP06	DT04-6P-EP14
CN-405	DEUTSCH	6	RH view camera	DT06-6S-EP06	DT04-6P-EP14
CN-406	DEUTSCH	3	RS 232	DT06-3S-EP06	DT04-3P-E005
CN-419	DEUTSCH	2	Swing parking-A3	DT06-2S-EP06	-
CN-420	DEUTSCH	2	Swing parking-A2	DT06-2S-EP06	-
CN-421	DEUTSCH	2	Swing parking-A1	DT06-2S-EP06	-
CN-427	MOLEX	4	Reader-RMS	039012040	026013096
CN-432	AMP	3	Cigar & power	174357-2	-
· Relay					
CR-1	RING-TERM	-	Battery relay	ST710289-2	-
CR-2	-	5	Horn relay	-	-
CR-4	-	5	Working lamp relay	-	-
CR-5	-	5	Anti restart relay	-	-
CR-7	-	5	Aircon compressor relay	-	-
CR-9	-	5	Cabin lamp relay	-	-
CR-13	-	5	Head lamp relay	-	-
CR-23	KET	2	Start relay	MG610320	S814-102001
CR-24	RING TERM	1	Preheat relay	S822-014000	-
CR-35	-	5	Power relay	-	-
CR-36	-	5	Preheat relay	-	-
CR-45	-	5	ECM power relay	-	-
CR-46	-	5	Fuel warmer relay	-	-
CR-62	-	5	Breaker relay	-	-
CR-85	-	5	Beacon lamp relay	-	-
· Switch					
CS-1	SHUR	1	Door switch	S822-014002	S822-114002
CS-2A	WP	6	Start key switch	S814-006100	-
CS-2B	DEUTSCH	3	BKCU	DT06-3S-EP06	DT04-3P-E005
CS-4	DEUTSCH	3	Safety switch	DT06-3S	-
CS-5	DEUTSCH	2	Horn switch	-	DT04-2P
CS-19	DEUTSCH	2	One touch decel switch	-	DT04-2P
CS-26	DEUTSCH	2	Breaker switch	DT06-2S	-

Connector number	Type	No. of pin	Destination	Connector part No.	
				Female	Male
CS-26A	AMP	2	Breaker pedal switch	S816-002002	S816-102002
CS-29	DEUTSCH	2	Power max switch	DT06-2S	-
CS-33	AMP	6	Emergency engine stop switch	S816-006002	S816-106002
CS-52	CARLING	10	Adjust & dozer switch	VC2-01	-
CS-53	AMP	1	Wiper cut switch	S822-014002	-
CS-67	CARLING	10	Quick clamp switch	VC2-01	-
CS-73	CARLING	10	Swing fine switch	VC2-01	-
CS-74A	AMP	2	Master switch	S813-030201	S813-130201
CS-74B	DEUTSCH	2	Master switch	DT06-2S-EP06	DT04-2P-E005
CS-83	CARLING	10	Swing lock switch	VC2-01	-
CS-99	CARLING	10	Air compressor switch	VC2-01	-
CS-108	CARLING	10	Auto grease switch	VC2-01	-
CS-142	DEUTSCH	3	Accel dial switch	DT06-3S	-
· Light					
CL-1	KET	3	Room lamp	MG651032	-
CL-2	AMP	1	Cigar lighter	S822-014002	S822-114002
CL-3	DEUTSCH	2	Head lamp-LH	DT06-2S-EP06	-
CL-4	DEUTSCH	2	Head lamp-RH	DT06-2S-EP06	-
CL-5	DEUTSCH	2	Work lamp-LH	DT06-2S-EP06	-
CL-6	DEUTSCH	2	Work lamp-RH	DT06-2S-EP06	-
CL-7	DEUTSCH	2	Beacon lamp	DT06-2S-EP06	DT04-2P
CL-8	DEUTSCH	2	Cab light-LH	DT06-2S-EP06	DT04-2P
CL-9	DEUTSCH	2	Cab light-RH	DT06-2S-EP06	DT04-2P
CL-10	DEUTSCH	2	Cab light	DT06-2S-EP06	DT04-2P
CL-24	DEUTSCH	2	Head lamp - Rear	DT06-2S-EP06	DT04-2P-E005
· Sensor, sender					
CD-1	AMP	2	Hydraulic oil temp sender	85202-1	-
CD-2	DEUTSCH	2	Fuel sender	DT06-2S-EP06	-
CD-6	DEUTSCH	3	Travel pressure switch	DT06-3S-EP06	-
CD-7	DEUTSCH	3	Working pressure switch	DT06-3S-EP06	-
CD-10	AMP	2	Air cleaner switch	85202-1	-
CD-24	DEUTSCH	3	Swing pressure sensor	DT06-3S-EP06	-
CD-31	DEUTSCH	3	Overload pressure sensor	DT06-3S-EP06	DT04-3P-EP06
CD-32	DEUTSCH	3	Boom up pressure sensor	DT06-3S-EP06	-
CD-35	DEUTSCH	3	Bucket in pressure sensor	DT06-3S-EP06	-
CD-36	DEUTSCH	3	Arm out pressure sensor	DT06-3S-EP06	-
CD-42	DEUTSCH	3	A1 pump pressure sensor	DT06-3S-EP06	-
CD-43	DEUTSCH	3	A2 pump pressure sensor	DT06-3S-EP06	-
CD-44	DEUTSCH	3	A3 pump pressure sensor	DT06-3S-EP06	-

Connector number	Type	No. of pin	Destination	Connector part No.	
				Female	Male
CD-45	DEUTSCH	2	WIF sensor	DT06-2S-EP06	DT04-2P-E005
CD-50	KET	2	Dozer pressure sensor	MG640795	-
CD-69	DEUTSCH	3	Attach pressure sensor	DT06-3S-EP06	-
CD-70	DEUTSCH	3	N1 pressure sensor	DT06-3S-EP06	-
CD-71	DEUTSCH	3	N2 pressure sensor	DT06-3S-EP06	-
CD-85	DEUTSCH	3	Boom down pressure sensor	DT06-3S-EP06	-
CD-87	DEUTSCH	3	Bucket out pressure sensor	DT06-3S-EP06	-
CD-90	DEUTSCH	3	Arm in pressure sensor	DT06-3S-EP06	-

## 2. CONNECTION TABLE FOR CONNECTORS

### 1) PA TYPE CONNECTOR

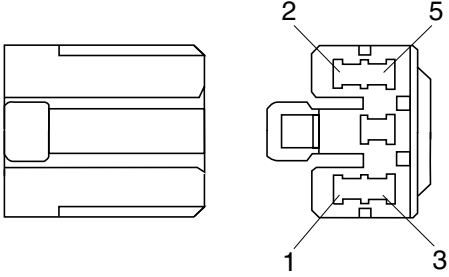
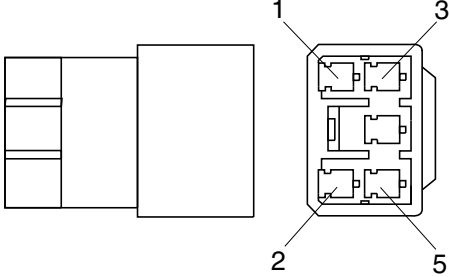
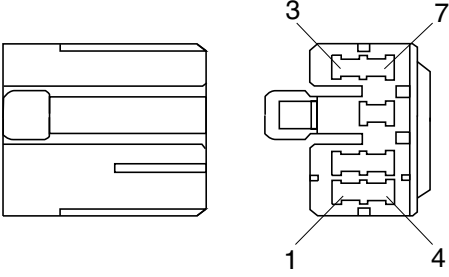
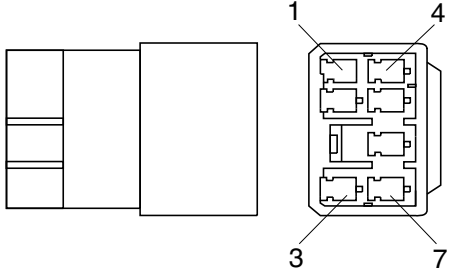
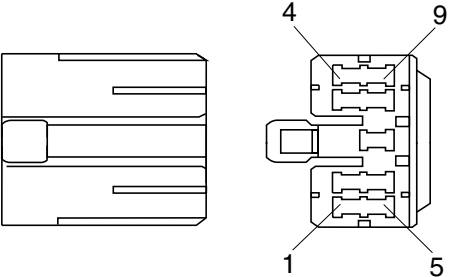
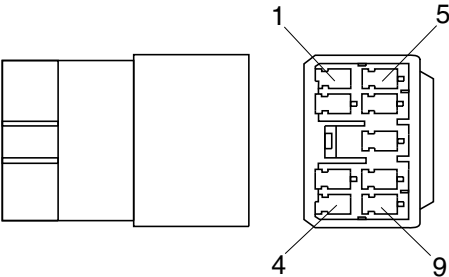
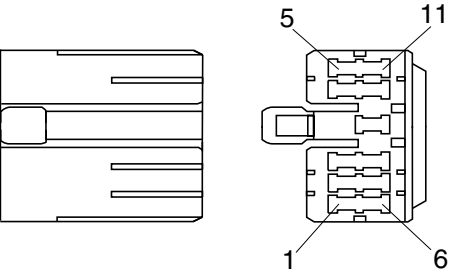
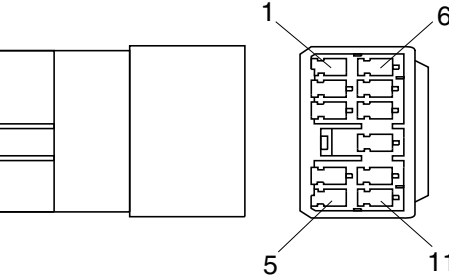
No. of pin	Receptacle connector (female)	Plug connector (male)
5	 <p style="text-align: center;">S811-005002</p>	 <p style="text-align: center;">S811-105002</p>
7	 <p style="text-align: center;">S811-007002</p>	 <p style="text-align: center;">S811-107002</p>
9	 <p style="text-align: center;">S811-009002</p>	 <p style="text-align: center;">3S811-109002</p>
11	 <p style="text-align: center;">S811-011002</p>	 <p style="text-align: center;">S811-111002</p>

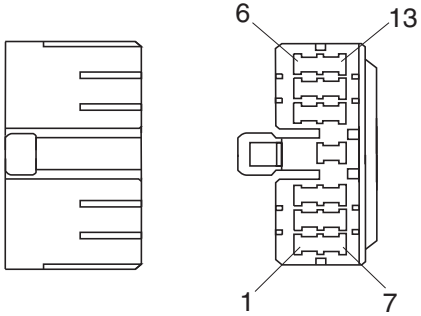
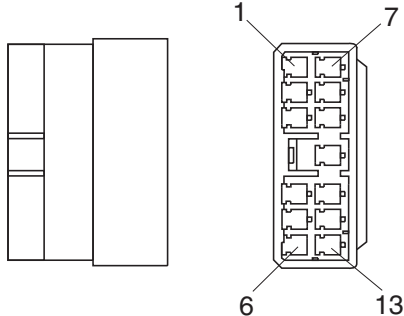
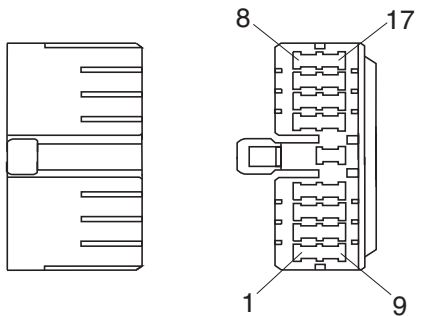
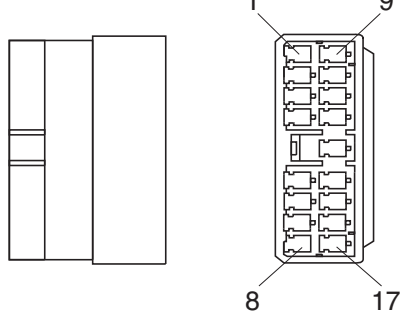
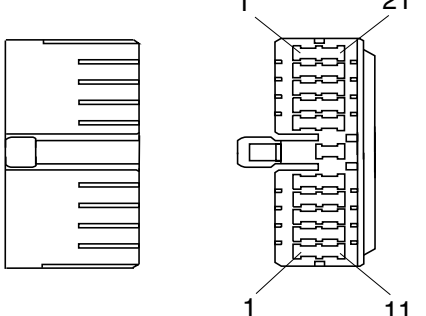
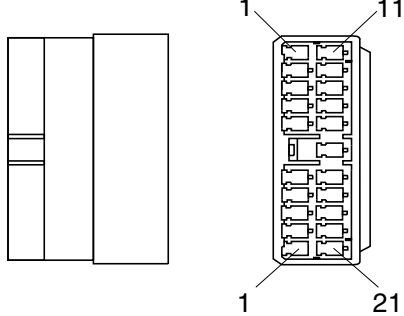
No. of pin	Receptacle connector (female)	Plug connector (male)
13	 <p style="text-align: center;">S811-013002</p>	 <p style="text-align: center;">S811-113002</p>
17	 <p style="text-align: center;">S811-017002</p>	 <p style="text-align: center;">S811-117002</p>
21	 <p style="text-align: center;">S811-021002</p>	 <p style="text-align: center;">S811-121002</p>

## 2) J TYPE CONNECTOR

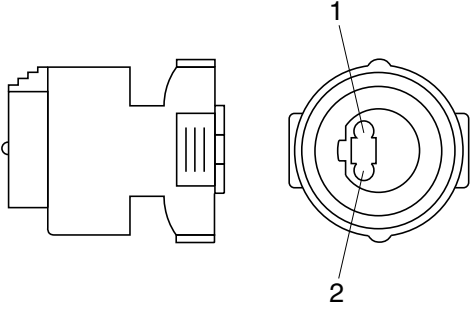
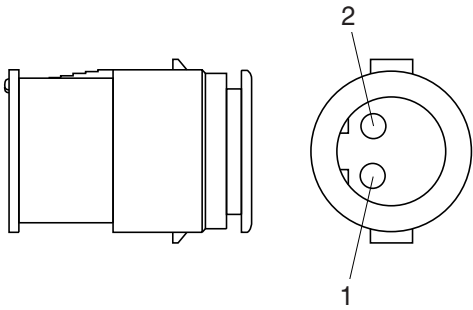
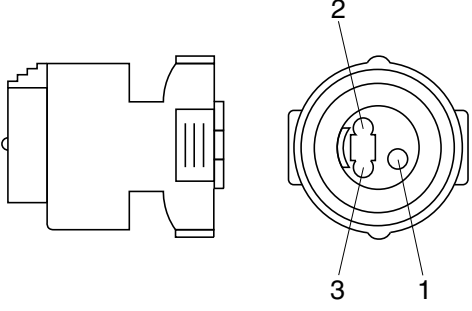
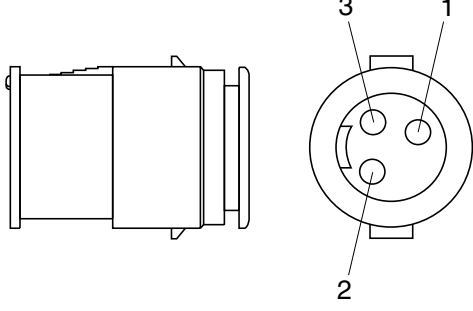
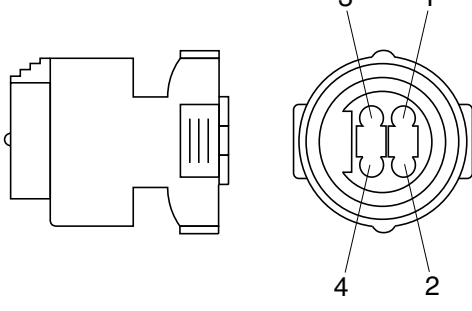
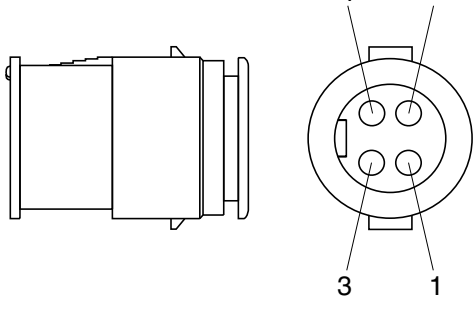
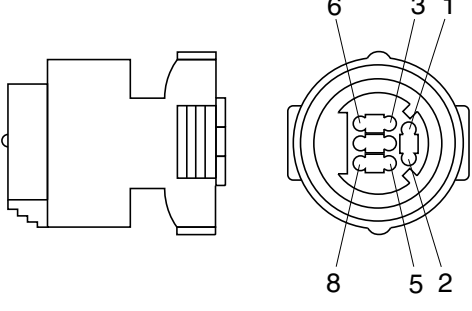
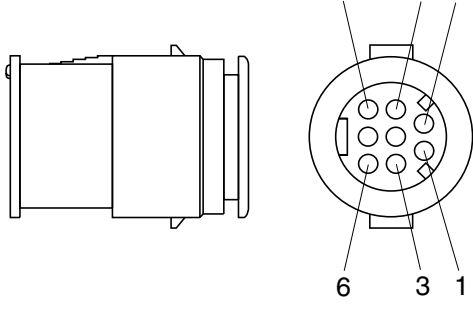
No. of pin	Receptacle connector (female)	Plug connector (male)
2	 <p style="text-align: center;">S816-002001</p>	 <p style="text-align: center;">S816-102001</p>
3	 <p style="text-align: center;">S816-003001</p>	 <p style="text-align: center;">S816-103001</p>
4	 <p style="text-align: center;">S816-004001</p>	 <p style="text-align: center;">S816-104001</p>
8	 <p style="text-align: center;">S816-008001</p>	 <p style="text-align: center;">S816-108001</p>

### 3) SWP TYPE CONNECTOR

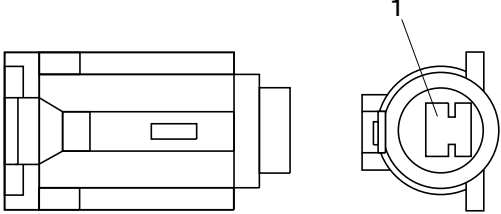
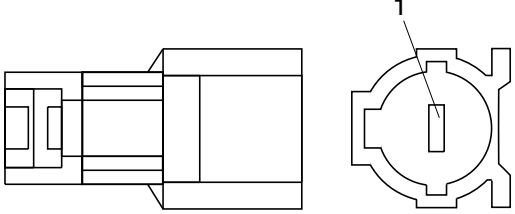
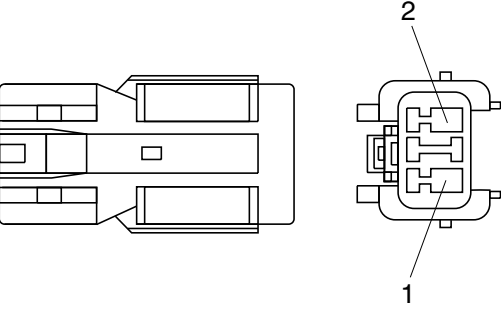
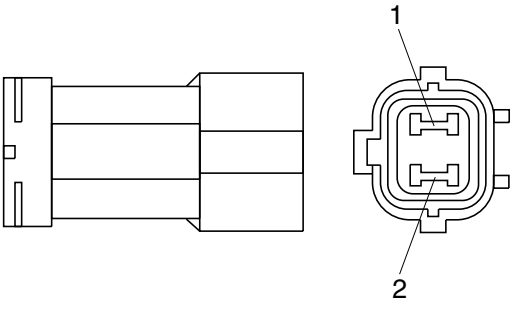
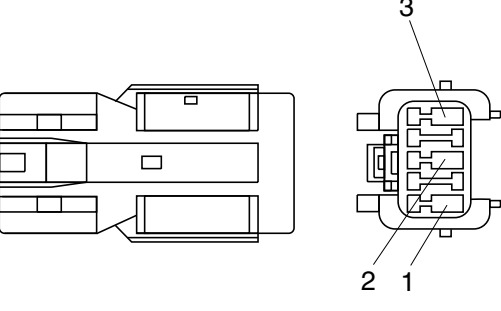
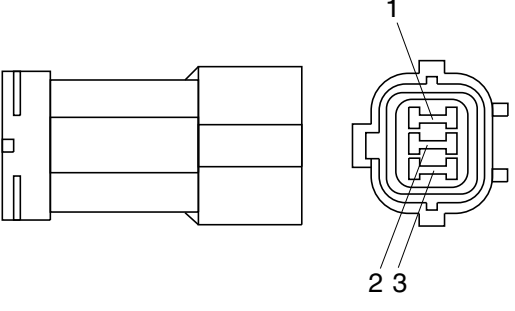
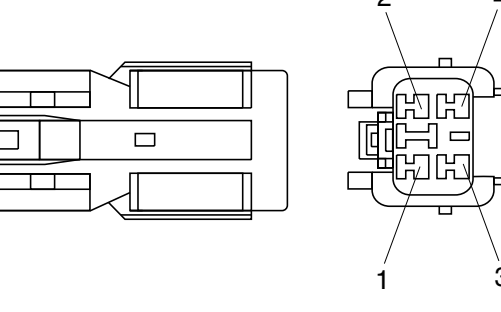
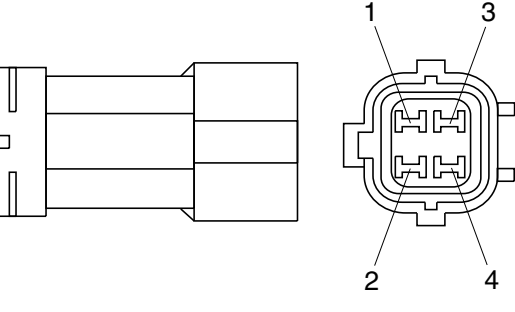
No. of pin	Receptacle connector (female)	Plug connector (male)
1	 <p data-bbox="687 680 836 712">S814-001000</p>	 <p data-bbox="1241 680 1390 712">S814-101000</p>
2	 <p data-bbox="687 1088 836 1120">S814-002000</p>	 <p data-bbox="1241 1088 1390 1120">S814-102000</p>
3	 <p data-bbox="687 1498 836 1529">S814-003000</p>	 <p data-bbox="1241 1498 1390 1529">S814-103000</p>
4	 <p data-bbox="687 1908 836 1939">S814-004000</p>	 <p data-bbox="1241 1908 1390 1939">S814-104000</p>

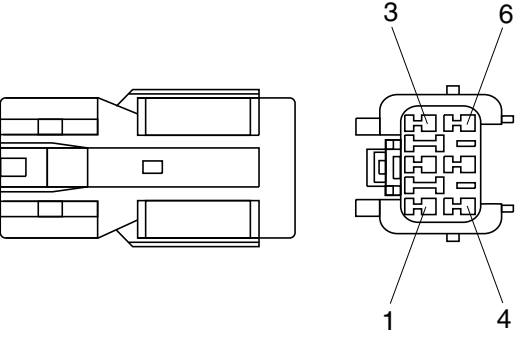
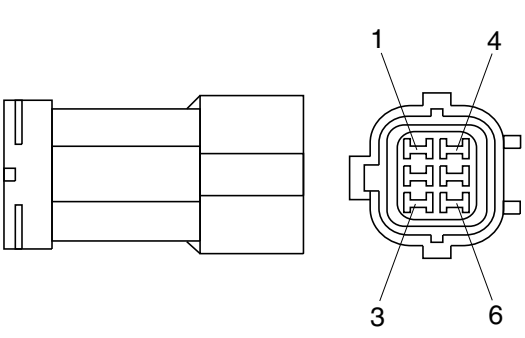
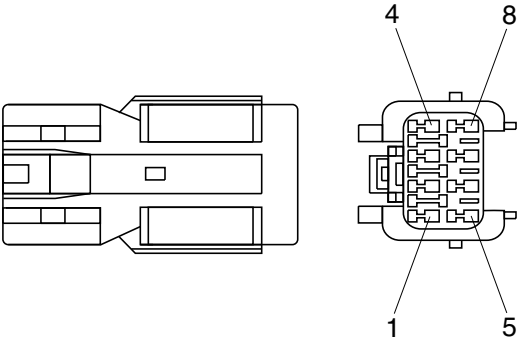
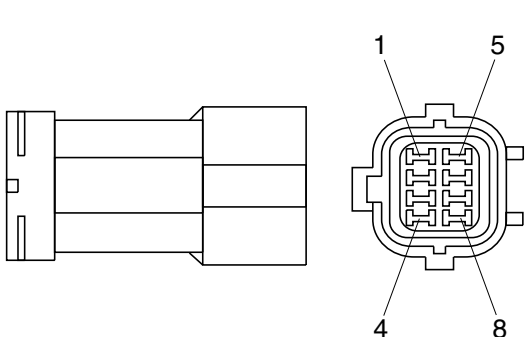
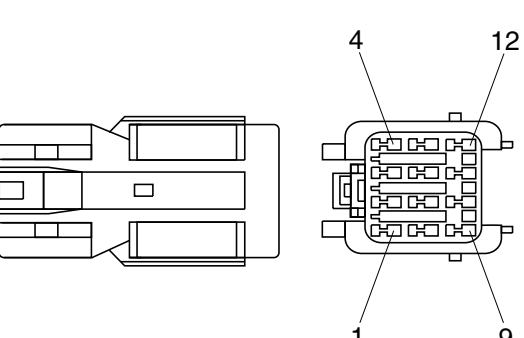
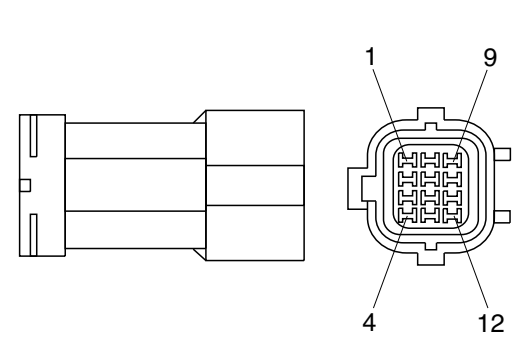
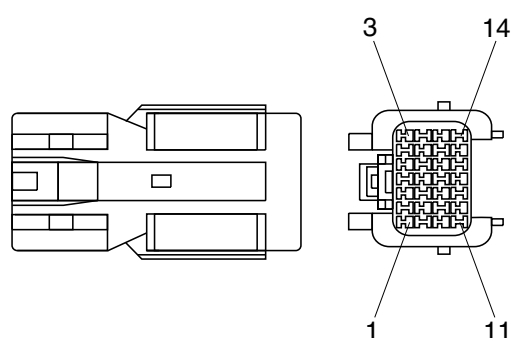
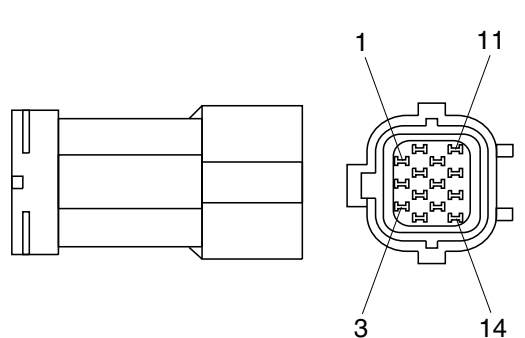
No. of pin	Receptacle connector (female)	Plug connector (male)
6	 <p data-bbox="686 638 837 672">S814-006000</p>	 <p data-bbox="1244 638 1396 672">S814-106000</p>
8	 <p data-bbox="686 1041 837 1075">S814-008000</p>	 <p data-bbox="1244 1041 1396 1075">S814-108000</p>
12	 <p data-bbox="686 1449 837 1482">S814-012000</p>	 <p data-bbox="1244 1449 1396 1482">S814-112000</p>
14	 <p data-bbox="686 1856 837 1890">S814-014000</p>	 <p data-bbox="1244 1856 1396 1890">S814-114000</p>

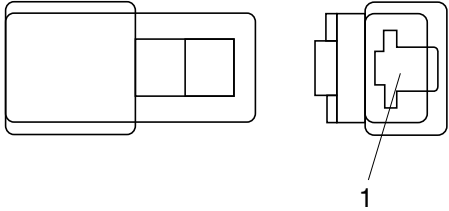
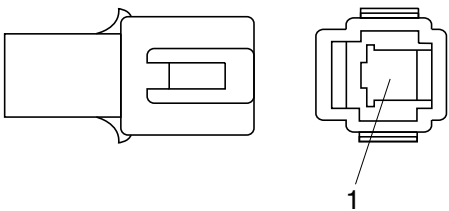
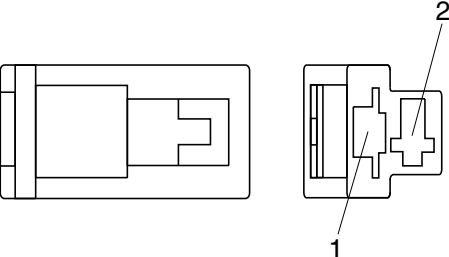
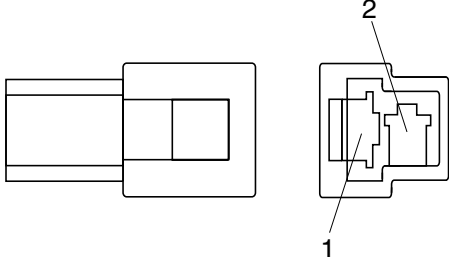
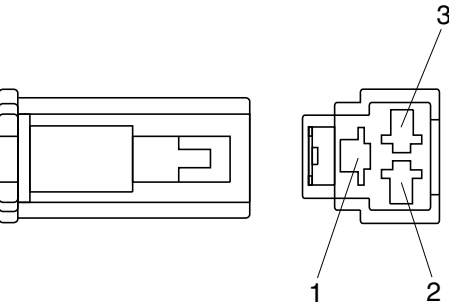
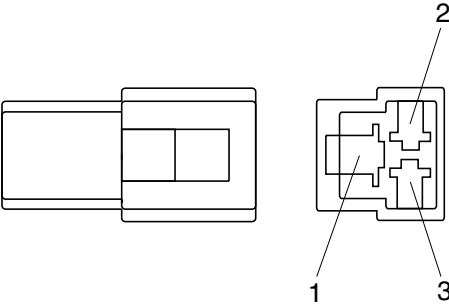
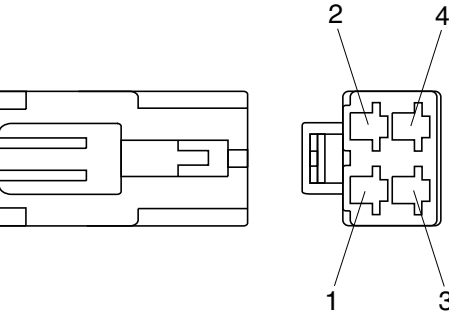
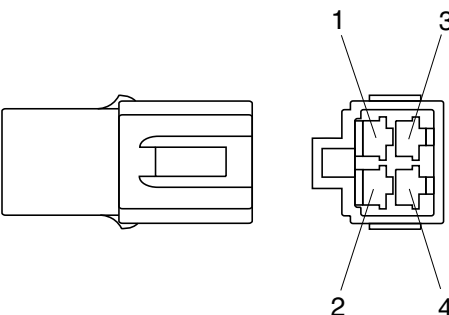

#### 4) CN TYPE CONNECTOR

No. of pin	Receptacle connector (female)	Plug connector (male)
1	 <p style="text-align: center;">S810-001202</p>	 <p style="text-align: center;">S810-101202</p>
2	 <p style="text-align: center;">S810-002202</p>	 <p style="text-align: center;">S810-102202</p>
3	 <p style="text-align: center;">S810-003202</p>	 <p style="text-align: center;">S810-103202</p>
4	 <p style="text-align: center;">S810-004202</p>	 <p style="text-align: center;">S810-104202</p>

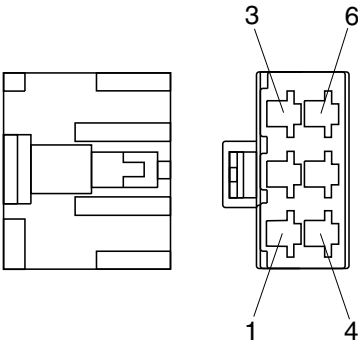
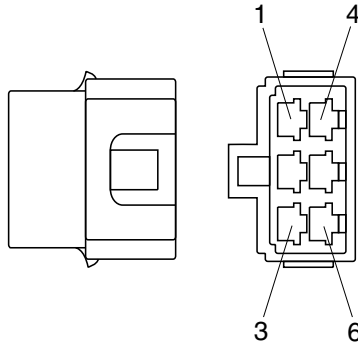
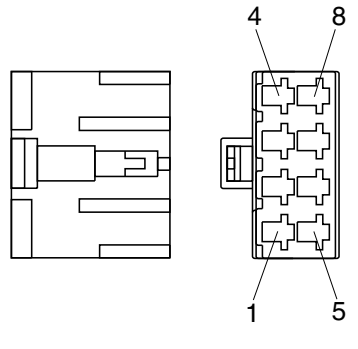
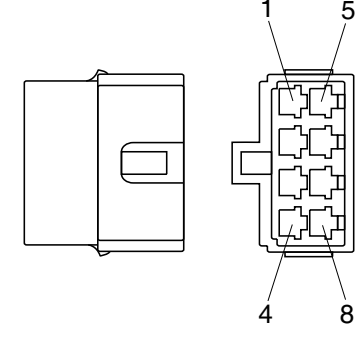
No. of pin	Receptacle connector (female)	Plug connector (male)
6	 <p data-bbox="686 638 837 672">S810-006202</p>	 <p data-bbox="1244 638 1396 672">S810-106202</p>
8	 <p data-bbox="686 1041 837 1075">S810-008202</p>	 <p data-bbox="1244 1041 1396 1075">S810-108202</p>

### 5) 375 FASTEN TYPE CONNECTOR

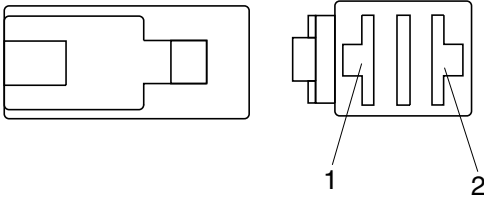
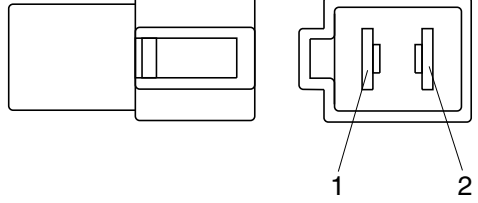
No. of pin	Receptacle connector (female)	Plug connector (male)
2	 <p style="text-align: center;">S810-002402</p>	 <p style="text-align: center;">S810-102402</p>

### 6) AMP ECONOSEAL CONNECTOR

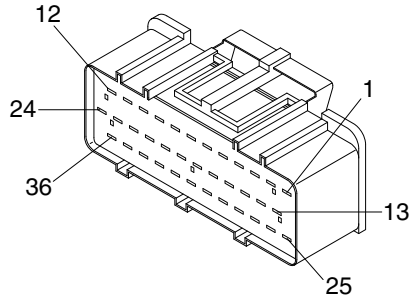
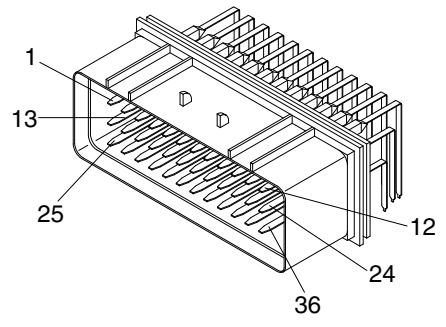
No. of pin	Receptacle connector (female)	Plug connector (male)
36	 <p style="text-align: center;">344111-1</p>	 <p style="text-align: center;">344108-1</p>

### 7) AMP TIMER CONNECTOR

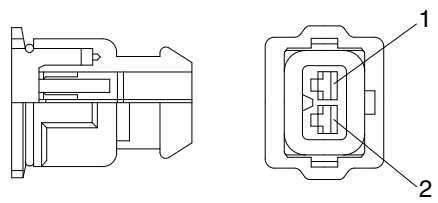
No. of pin	Receptacle connector (female)	Plug connector (male)
2	 <p style="text-align: center;">85202-1</p>	

### 8) AMP 040 MULTILOCK CONNECTOR

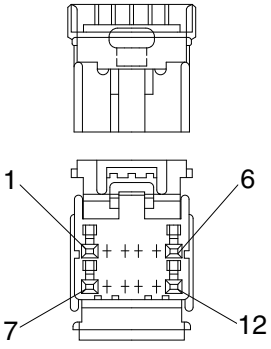
No. of pin	Receptacle connector (female)	Plug connector (male)
12	 <p style="text-align: right;">174045-2</p>	

### 9) AMP 070 MULTILOCK CONNECTOR

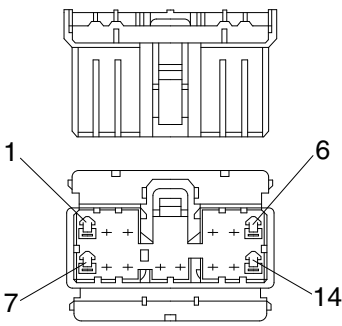
No. of pin	Receptacle connector (female)	Plug connector (male)
14	 <p style="text-align: right;">173852</p>	

### 10) AMP FASTIN - FASTON CONNECTOR

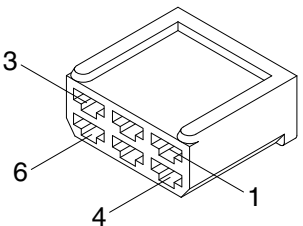
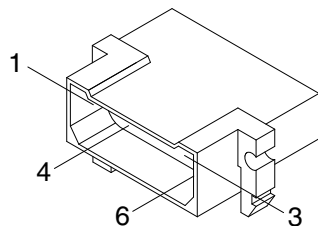
No. of pin	Receptacle connector (female)	Plug connector (male)
6	 <p style="text-align: right;">925276-0</p>	 <p style="text-align: right;">480003-9</p>

### 11) KET 090 CONNECTOR

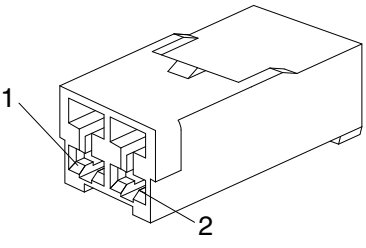
No. of pin	Receptacle connector (female)	Plug connector (male)
2	 <p style="text-align: right;">MG610070</p>	

### 12) KET 090 WP CONNECTORS

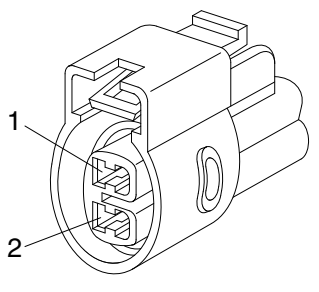
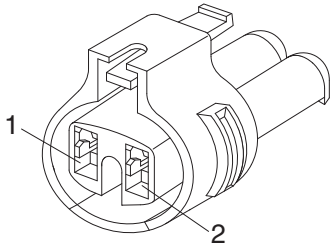
No. of pin	Receptacle connector (female)	Plug connector (male)
2	 <p style="text-align: right;">MG640605</p>	
2	 <p style="text-align: right;">MG640795</p>	

### 13) KET SDL CONNECTOR

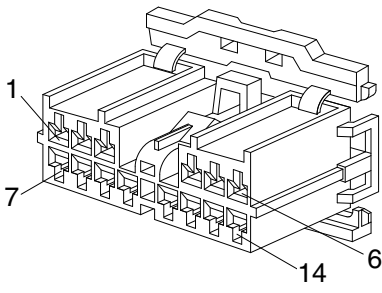
No. of pin	Receptacle connector (female)	Plug connector (male)
14	 <p data-bbox="710 683 837 705">MG610406</p>	

## 14) DEUTSCH DT CONNECTORS

DT 06 - 3S - ★★☆☆

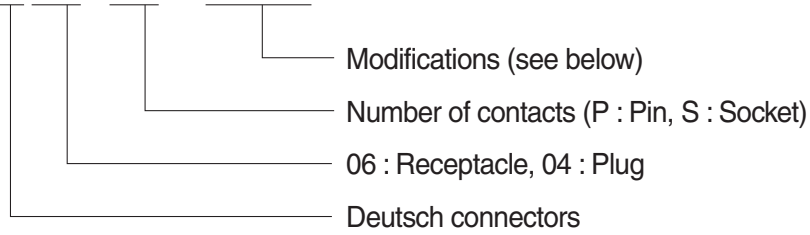

### ※ Modification

E003 : Standard end cap - gray

E004 : Color of connector to be black

E005 : Combination - E004 & E003

EP04 : End cap

EP06 : Combination P012 & EP04

P012 : Front seal enhancement - connectors color to black for 2, 3, 4 & 6pin

No. of pin	Receptacle connector (female)	Plug connector (male)
2	<p>DT06-2S</p>	<p>DT04-2P</p>
3	<p>DT06-3S</p>	<p>DT04-3P</p>
4	<p>DT06-4S</p>	<p>DT04-4P</p>

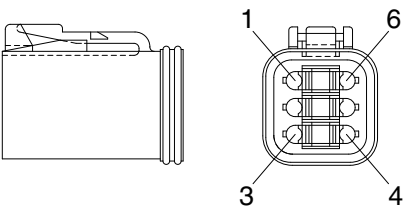
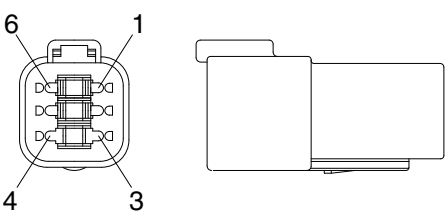
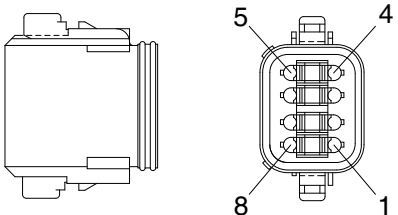
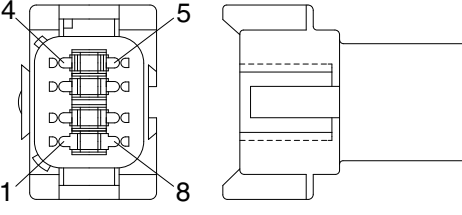
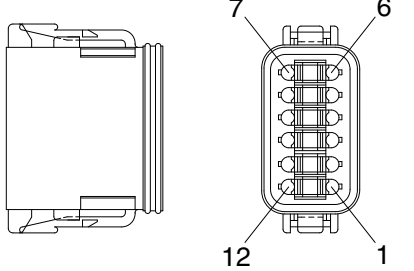
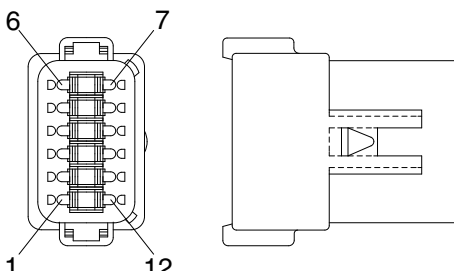
No. of pin	Receptacle connector (female)	Plug connector (male)
6	 <p style="text-align: center;">DT06-6S</p>	 <p style="text-align: center;">DT04-6P</p>
8	 <p style="text-align: center;">DT06-8S</p>	 <p style="text-align: center;">DT04-8P</p>
12	 <p style="text-align: center;">DT06-12S</p>	 <p style="text-align: center;">DT04-12P</p>

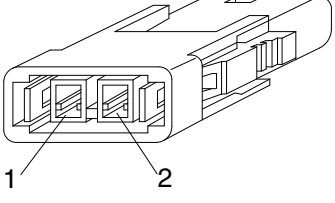

### 15) MOLEX 2CKTS CONNECTOR

No. of pin	Receptacle connector (female)	Plug connector (male)
2	 <p data-bbox="702 683 837 705">35215-0200</p>	

### 16) ITT SWF CONNECTOR

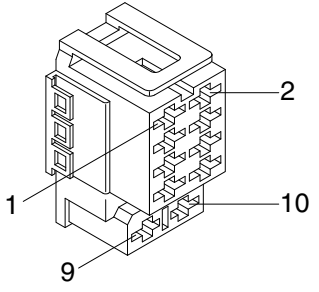
No. of pin	Receptacle connector (female)	Plug connector (male)
10	 <p data-bbox="694 1288 837 1310">SWF593757</p>	

### 17) MWP NMWP CONNECTOR

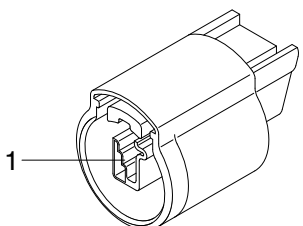
No. of pin	Receptacle connector (female)	Plug connector (male)
1	 <p data-bbox="686 1892 837 1915">NMWP01F-B</p>	

### 18) ECONOSEAL J TYPE CONNECTORS

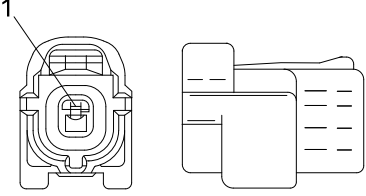
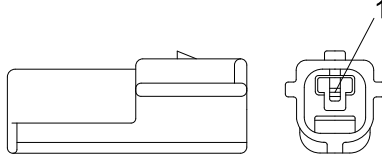
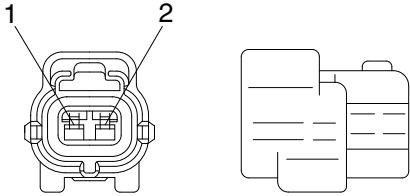
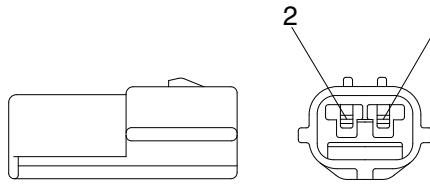
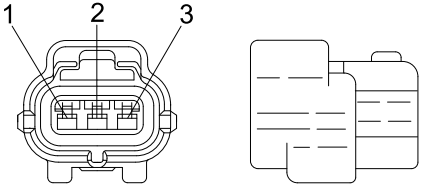
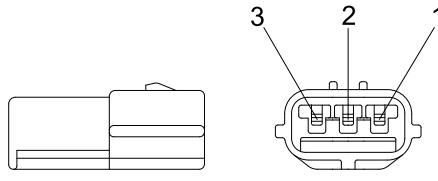
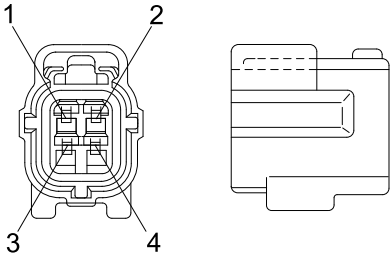
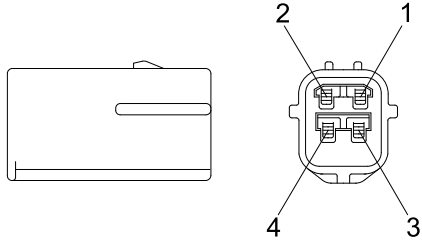
No. of pin	Receptacle connector (female)	Plug connector (male)
1	 <p style="text-align: right;">S816-001002</p>	 <p style="text-align: left;">S816-101002</p>
2	 <p style="text-align: right;">S816-002002</p>	 <p style="text-align: left;">S816-102002</p>
3	 <p style="text-align: right;">S816-003002</p>	 <p style="text-align: left;">S816-103002</p>
4	 <p style="text-align: right;">S816-004002</p>	 <p style="text-align: left;">S816-104002</p>

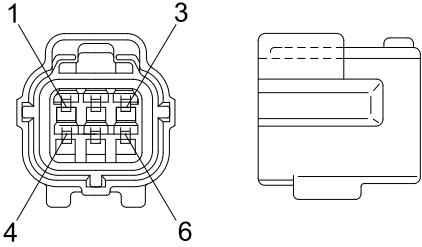
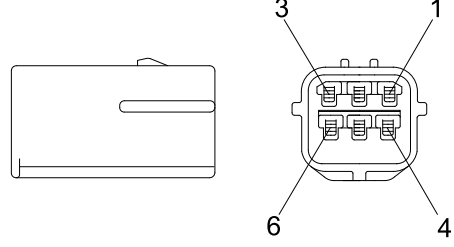
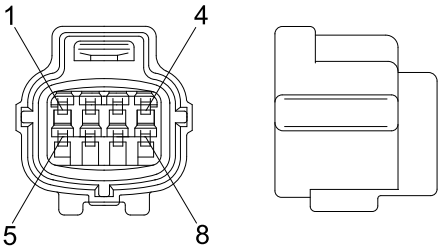
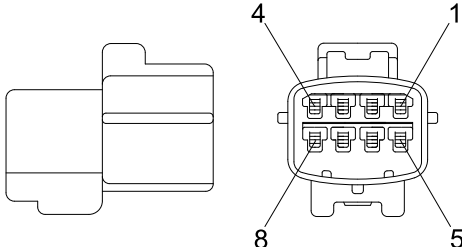
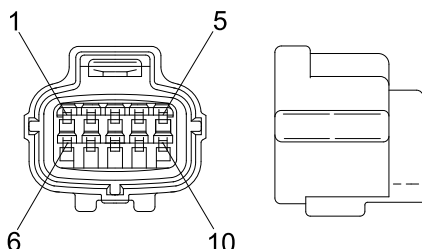
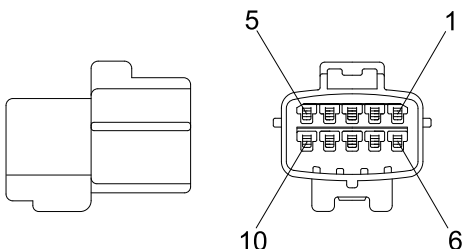
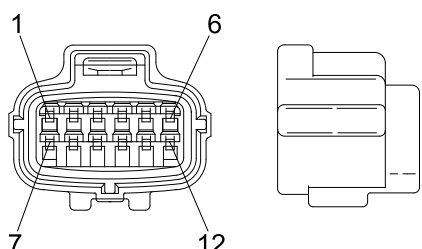
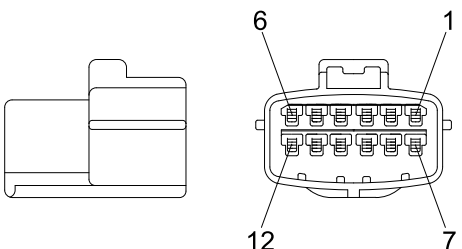
No. of pin	Receptacle connector (female)	Plug connector (male)
6	 <p data-bbox="686 638 837 672">S816-006002</p>	 <p data-bbox="1236 638 1388 672">S816-106002</p>
8	 <p data-bbox="686 1041 837 1075">S816-008002</p>	 <p data-bbox="1236 1041 1388 1075">S816-108002</p>
10	 <p data-bbox="686 1444 837 1478">S816-010002</p>	 <p data-bbox="1236 1444 1388 1478">S816-110002</p>
12	 <p data-bbox="686 1848 837 1881">S816-012002</p>	 <p data-bbox="1236 1848 1388 1881">S816-112002</p>

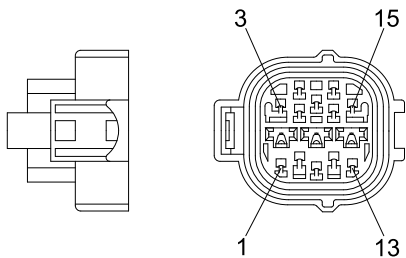
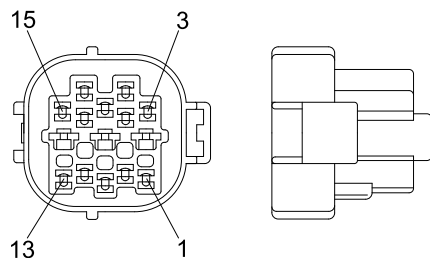
No. of pin	Receptacle connector (female)	Plug connector (male)
15	 <p style="text-align: center;">368301-1</p>	 <p style="text-align: center;">2-85262-1</p>

### 19) METRI-PACK TYPE CONNECTOR

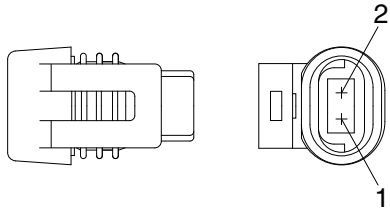
No. of pin	Receptacle connector (female)	Plug connector (male)
2	 <p style="text-align: center;">12040753</p>	

### 20) DEUTSCH HD30 CONNECTOR

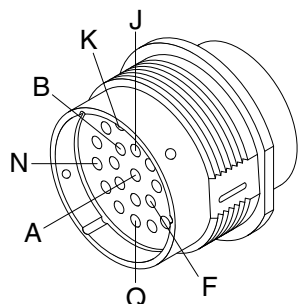
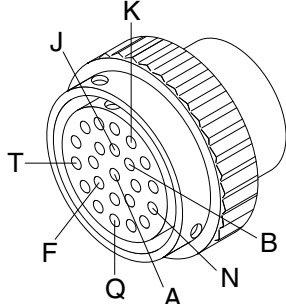
No. of pin	Receptacle connector (female)	Plug connector (male)
23	 <p style="text-align: center;">HD36-24-23SN</p>	 <p style="text-align: center;">HD34-24-23PN</p>

### 21) DEUTSCH MCU CONNECTOR

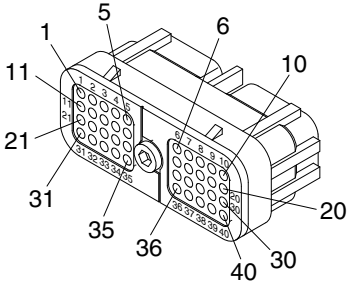
No. of pin	Receptacle connector (Female)	Plug connector (Male)
40	 <p style="text-align: right;">DRC26-40SA/B</p>	

### 22) DEUTSCH SERVICE TOOL CONNECTOR

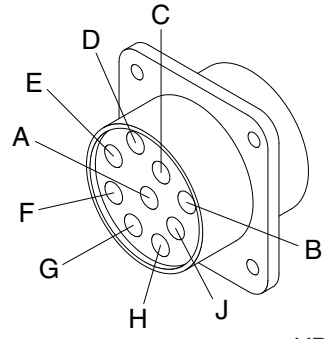
No. of pin	Receptacle connector (Female)	Plug connector (Male)
9	 <p style="text-align: right;">HD10-9-96P</p>	

### 23) AMP FUEL WARMER CONNECTOR

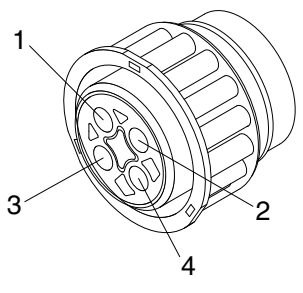
No. of pin	Receptacle connector (Female)	Plug connector (Male)
4	 <p style="text-align: right;">2-967325-3</p>	

### 24) DEUTSCH ENGINE ECM CONNECTOR

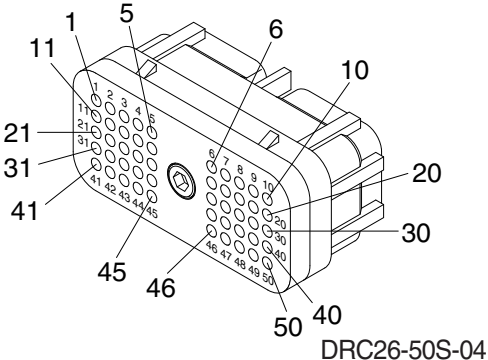
No. of pin	Receptacle connector (Female)	Plug connector (Male)
50	 <p style="text-align: right;">DRC26-50S-04</p>	

### 25) DEUTSCH INTERMEDIATE CONNECTOR

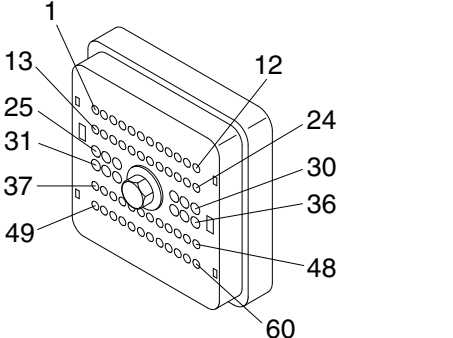
No. of pin	Receptacle connector (Female)	Plug connector (Male)
60	 <p style="text-align: right;">DRB16-60SAE-L018</p>	