

SECTION 8 DISASSEMBLY AND ASSEMBLY

Group 1	Precaution	8-1
Group 2	Tightening Torque	8-4
Group 3	Pump Device	8-7
Group 4	Main Control Valve	8-29
Group 5	Swing Device	8-43
Group 6	Travel Device	8-62
Group 7	RCV Lever	8-126
Group 8	Turning Joint	8-140
Group 9	Boom, Arm and Bucket Cylinder	8-145
Group 10	Undercarriage	8-164
Group 11	Work Equipment	8-178

SECTION 8 DISASSEMBLY AND ASSEMBLY

GROUP 1 PRECAUTIONS

1. REMOVAL WORK

- 1) Lower the work equipment completely to the ground.
If the coolant contains antifreeze, dispose of it correctly.
- 2) After disconnecting hoses or tubes, cover them or fit blind plugs to prevent dirt or dust from entering.
- 3) When draining oil, prepare a container of adequate size to catch the oil.
- 4) Confirm the match marks showing the installation position, and make match marks in the necessary places before removal to prevent any mistake when assembling.
- 5) To prevent any excessive force from being applied to the wiring, always hold the connectors when disconnecting the connectors.
- 6) Fit wires and hoses with tags to show their installation position to prevent any mistake when installing.
- 7) Check the number and thickness of the shims, and keep in a safe place.
- 8) When raising components, be sure to use lifting equipment of ample strength.
- 9) When using forcing screws to remove any components, tighten the forcing screws alternately.
- 10) Before removing any unit, clean the surrounding area and fit a cover to prevent any dust or dirt from entering after removal.
- 11) When removing hydraulic equipment, first release the remaining pressure inside the hydraulic tank and the hydraulic piping.
- 12) If the part is not under hydraulic pressure, the following corks can be used.

Nominal number	Dimensions		
	D	d	L
06	6	5	8
08	8	6.5	11
10	10	8.5	12
12	12	10	15
14	14	11.5	18
16	16	13.5	20
18	18	15	22
20	20	17	25
22	22	18.5	28
24	24	20	30
27	27	22.5	34

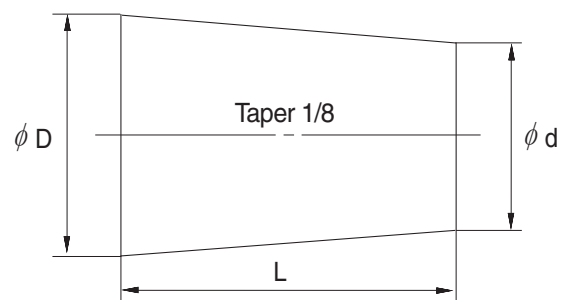

2. INSTALL WORK

- 1) Tighten all bolts and nuts (sleeve nuts) to the specified torque.
- 2) Install the hoses without twisting or interference.
- 3) Replace all gaskets, O-rings, cotter pins, and lock plates with new parts.
- 4) Bend the cotter pin or lock plate securely.
- 5) When coating with adhesive, clean the part and remove all oil and grease, then coat the threaded portion with 2-3 drops of adhesive.
- 6) When coating with gasket sealant, clean the surface and remove all oil and grease, check that there is no dirt or damage, then coat uniformly with gasket sealant.
- 7) Clean all parts, and correct any damage, dents, burrs, or rust.
- 8) Coat rotating parts and sliding parts with engine oil.
- 9) When press fitting parts, coat the surface with antifriction compound (LM-P).
- 10) After installing snap rings, check that the snap ring is fitted securely in the ring groove (Check that the snap ring moves in the direction of rotation).
- 11) When connecting wiring connectors, clean the connector to remove all oil, dirt, or water, then connect securely.
- 12) When using eyebolts, check that there is no deformation or deterioration, and screw them in fully.
- 13) When tightening split flanges, tighten uniformly in turn to prevent excessive tightening on one side.
- 14) When operating the hydraulic cylinders for the first time after repairing and reassembling the hydraulic cylinders, pumps, or other hydraulic equipment or piping, always bleed the air from the hydraulic cylinders as follows:
 - (1) Start the engine and run at low idling.
 - (2) Operate the control lever and actuate the hydraulic cylinder 4-5 times, stopping 100mm before the end of the stroke.
 - (3) Next, operate the piston rod to the end of its stroke to relieve the circuit. (The air bleed valve is actuated to bleed the air.)
 - (4) After completing this operation, raise the engine speed to the normal operating condition.
 - ※ If the hydraulic cylinder has been replaced, carry out this procedure before assembling the rod to the work equipment.
 - ※ Carry out the same operation on machines that have been in storage for a long time after completion of repairs.

3. COMPLETING WORK

- 1) If the coolant has been drained, tighten the drain valve, and add water to the specified level. Run the engine to circulate the water through the system. Then check the water level again.
- 2) If the hydraulic equipment has been removed and installed again, add engine oil to the specified level. Run the engine to circulate the oil through the system. Then check the oil level again.
- 3) If the piping or hydraulic equipment, such as hydraulic cylinders, pumps, or motors, have been removed for repair, always bleed the air from the system after reassembling the parts.
- 4) Add the specified amount of grease (molybdenum disulphied grease) to the work equipment related parts.

GROUP 2 TIGHTENING TORQUE

1. MAJOR COMPONENTS

No.	Descriptions	Bolt size	Torque		
			kgf · m	lbf · ft	
1	Engine	Engine mounting bolt (engine-bracket, FR)	M12 × 1.75	11.5 ± 1.0	81.2 ± 7.2
2		Engine mounting bolt (engine-bracket, RR)	M12 × 1.75	11.5 ± 1.0	81.2 ± 7.2
3		Engine mounting bolt (bracket-frame, FR)	M16 × 2.0	29.7 ± 4.5	215 ± 32.5
4		Engine mounting bolt (bracket-frame, RR)	M16 × 2.0	29.7 ± 4.5	215 ± 32.5
5		Radiator mounting bolt	M16 × 2.0	29.7 ± 4.5	215 ± 32.5
6		Coupling mounting socket bolt	M16 × 2.0	32.0 ± 1.6	231 ± 11.6
7		Main pump housing mounting bolt	M10 × 1.5	6.0 ± 1.5	43.4 ± 10.9
8	Hydraulic system	Main pump mounting socket bolt	M16 × 2.0	35.6 ± 7.1	257 ± 51.4
9		Main control valve mounting bolt	M12 × 1.75	12.2 ± 1.3	88.2 ± 9.4
10		Fuel tank mounting bolt	M20 × 2.5	57.9 ± 8.7	419 ± 62.9
11		Hydraulic oil tank mounting bolt	M20 × 2.5	57.9 ± 8.7	419 ± 62.9
12		Turning joint mounting bolt, nut	M12 × 1.75	12.8 ± 3.0	92.6 ± 21.7
13	Power train system	Swing motor mounting bolt	M16 × 2.0	29.6 ± 3.2	214 ± 23.1
14		Swing bearing upper part mounting bolt	M18 × 2.5	41.3 ± 4.5	299 ± 32.5
15		Swing bearing lower part mounting bolt	M16 × 1.5	31.3 ± 3.2	226 ± 23.1
16		Travel motor mounting bolt	M16 × 2.0	25.7 ± 4.0	186 ± 28.9
17		Sprocket mounting bolt	M16 × 2.0	29.7 ± 3.0	215 ± 21.7
18	Under carriage	Carrier roller mounting bolt, nut	M16 × 2.0	29.7 ± 3.0	215 ± 21.7
19		Track roller mounting bolt	M16 × 2.0	29.7 ± 3.0	215 ± 21.7
20		Track roller mounting bolt (HIGH WALKER)	M 20 × 2.5	57.9 ± 6.0	419 ± 43.4
21		Track tension cylinder mounting bolt	M16 × 2.0	29.7 ± 4.5	215 ± 32.5
22		Track shoe mounting bolt, nut	5/8 - 18UNF	42 ± 4.0	304 ± 28.9
23		Track guard mounting bolt	M16 × 2.0	29.6 ± 3.2	214 ± 23.1
24	Others	Counterweight mounting bolt	M27 × 3.0	135 ± 15	976 ± 108
25		Cab mounting bolt	M12 × 1.75	12.8 ± 3.0	92.6 ± 21.7
26		Operator's seat mounting bolt	M 8 × 1.25	4.05 ± 0.8	29.3 ± 5.8

※ For tightening torque of engine and hydraulic components, see engine maintenance guide and service manual.

2. TORQUE CHART

Use following table for unspecified torque.

1) BOLT AND NUT

(1) Coarse thread

Bolt size	8.8T		10.9T		12.9T	
	kgf·m	lbf·ft	kgf·m	lbf·ft	kgf·m	lbf·ft
M 6 × 1.0	0.8 ~ 1.2	5.8 ~ 8.6	1.2 ~ 1.8	8.7 ~ 13.0	1.5 ~ 2.1	10.9 ~ 15.1
M 8 × 1.25	2.0 ~ 3.0	14.5 ~ 21.6	2.8 ~ 4.2	20.3 ~ 30.4	3.4 ~ 5.0	24.6 ~ 36.1
M10 × 1.5	4.0 ~ 6.0	29.0 ~ 43.3	5.6 ~ 8.4	40.5 ~ 60.8	6.8 ~ 10.0	49.2 ~ 72.3
M12 × 1.75	6.8 ~ 10.2	50.0 ~ 73.7	9.6 ~ 14.4	69.5 ~ 104	12.3 ~ 16.5	89.0 ~ 119
M14 × 2.0	10.9 ~ 16.3	78.9 ~ 117	16.3 ~ 21.9	118 ~ 158	19.5 ~ 26.3	141 ~ 190
M16 × 2.0	17.9 ~ 24.1	130 ~ 174	25.1 ~ 33.9	182 ~ 245	30.2 ~ 40.8	141 ~ 295
M18 × 2.5	24.8 ~ 33.4	180 ~ 241	34.8 ~ 47.0	252 ~ 340	41.8 ~ 56.4	302 ~ 407
M20 × 2.5	34.9 ~ 47.1	253 ~ 340	49.1 ~ 66.3	355 ~ 479	58.9 ~ 79.5	426 ~ 575
M22 × 2.5	46.8 ~ 63.2	339 ~ 457	65.8 ~ 88.8	476 ~ 642	78.9 ~ 106	570 ~ 766
M24 × 3.0	60.2 ~ 81.4	436 ~ 588	84.6 ~ 114	612 ~ 824	102 ~ 137	738 ~ 991
M30 × 3.5	120 ~ 161	868 ~ 1164	168 ~ 227	1216 ~ 1641	202 ~ 272	1461 ~ 1967

(2) Fine thread

Bolt size	8.8T		10.9T		12.9T	
	kgf · m	lbf · ft	kgf · m	lbf · ft	kgf · m	lbf · ft
M 8 × 1.0	2.1 ~ 3.1	15.2 ~ 22.4	3.0 ~ 4.4	21.7 ~ 31.8	3.6 ~ 5.4	26.1 ~ 39.0
M10 × 1.25	4.2 ~ 6.2	30.4 ~ 44.9	5.9 ~ 8.7	42.7 ~ 62.9	7.0 ~ 10.4	50.1 ~ 75.2
M12 × 1.25	7.3 ~ 10.9	52.8 ~ 78.8	10.3 ~ 15.3	74.5 ~ 110	13.1 ~ 17.7	94.8 ~ 128
M14 × 1.5	12.4 ~ 16.6	89.7 ~ 120	17.4 ~ 23.4	126 ~ 169	20.8 ~ 28.0	151 ~ 202
M16 × 1.5	18.7 ~ 25.3	136 ~ 182	26.3 ~ 35.5	191 ~ 256	31.6 ~ 42.6	229 ~ 308
M18 × 1.5	27.1 ~ 36.5	196 ~ 264	38.0 ~ 51.4	275 ~ 371	45.7 ~ 61.7	331 ~ 446
M20 × 1.5	37.7 ~ 50.9	273 ~ 368	53.1 ~ 71.7	384 ~ 518	63.6 ~ 86.0	460 ~ 622
M22 × 1.5	51.2 ~ 69.2	370 ~ 500	72.0 ~ 97.2	521 ~ 703	86.4 ~ 116	625 ~ 839
M24 × 2.0	64.1 ~ 86.5	464 ~ 625	90.1 ~ 121	652 ~ 875	108 ~ 146	782 ~ 1056
M30 × 2.0	129 ~ 174	933 ~ 1258	181 ~ 245	1310 ~ 1772	217 ~ 294	1570 ~ 2126

2) PIPE AND HOSE (FLARE TYPE)

Thread size (PF)	Width across flat (mm)	kgf · m	lbf · ft
1/4"	19	4	28.9
3/8"	22	5	36.2
1/2"	27	9.5	68.7
3/4"	36	18	130.2
1"	41	21	151.9
1-1/4"	50	35	253.2

3) PIPE AND HOSE (ORFS TYPE)

Thread size (UNF)	Width across flat (mm)	kgf · m	lbf · ft
9/16-18	19	4	28.9
11/16-16	22	5	36.2
13/16-16	27	9.5	68.7
1-3/16-12	36	18	130.2
1-7/16-12	41	21	151.9
1-11/16-12	50	35	253.2

4) FITTING

Thread size	Width across flat (mm)	kgf · m	lbf · ft
1/4"	19	4	28.9
3/8"	22	5	36.2
1/2"	27	9.5	68.7
3/4"	36	18	130.2
1"	41	21	151.9
1-1/4"	50	35	253.2

GROUP 3 PUMP DEVICE

1. REMOVAL AND INSTALL

1) REMOVAL

- (1) Lower the work equipment to the ground and stop the engine.
- (2) Operate the control levers and pedals several times to release the remaining pressure in the hydraulic piping
- (3) Loosen the breather slowly to release the pressure inside the hydraulic tank.

▲ Escaping fluid under pressure can penetrate the skin causing serious injury.

- (4) Loosen the drain plug under the hydraulic tank and drain the oil from the hydraulic tank.

· Hydraulic tank quantity : 124 ℓ
(32.8 U.S. gal)

- (5) Remove socket bolts (11) and disconnect hoses (1,2).
- (6) Disconnect pilot line hoses (5, 6, 7, 8, 9, 10).
- (7) Remove socket bolts (12) and disconnect pump suction pipe (4).

※ When pump suction tube is disconnected, the oil inside the piping will flow out, so catch it in oil pan.

- (8) Sling the pump assembly and remove the pump mounting bolts.
 - Weight : 100 kg (220 lb)
 - Tightening torque : $29.7 \pm 4.5 \text{ kgf} \cdot \text{m}$
($215 \pm 32.5 \text{ lbf} \cdot \text{ft}$)

※ Pull out the pump assembly from housing.

When removing the pump assembly, check that all the hoses have been disconnected.



13031GE18

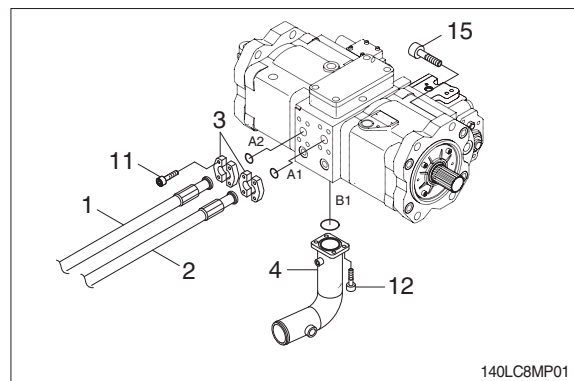

140LC8MP01

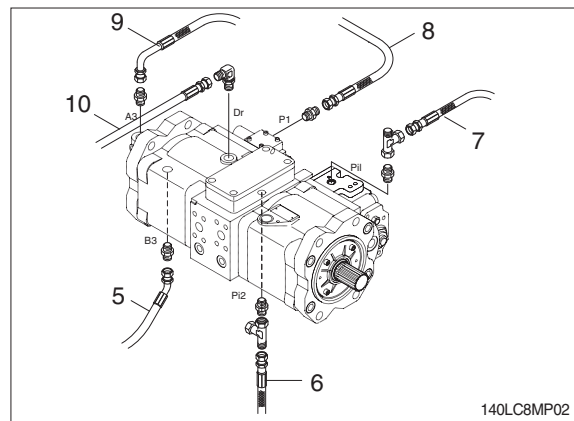

140LC8MP02

2) INSTALL

- (1) Carry out installation in the reverse order to removal.
- (2) Remove the suction strainer and clean it.
- (3) Replace return filter with new one.
- (4) Remove breather and clean it.
- (5) After adding oil to the hydraulic tank to the specified level.
- (6) Bleed the air from the hydraulic pump.
 - ① Remove the air vent plug (2EA).
 - ② Tighten plug lightly.
 - ③ Start the engine, run at low idling, and check oil come out from plug.
 - ④ Tighten plug.
- (7) Start the engine, run at low idling (3~5 minutes) to circulate the oil through the system.
- (8) Confirm the hydraulic oil level and check the hydraulic oil leak or not.

2. MAIN PUMP (1/2)

1) STRUCTURE

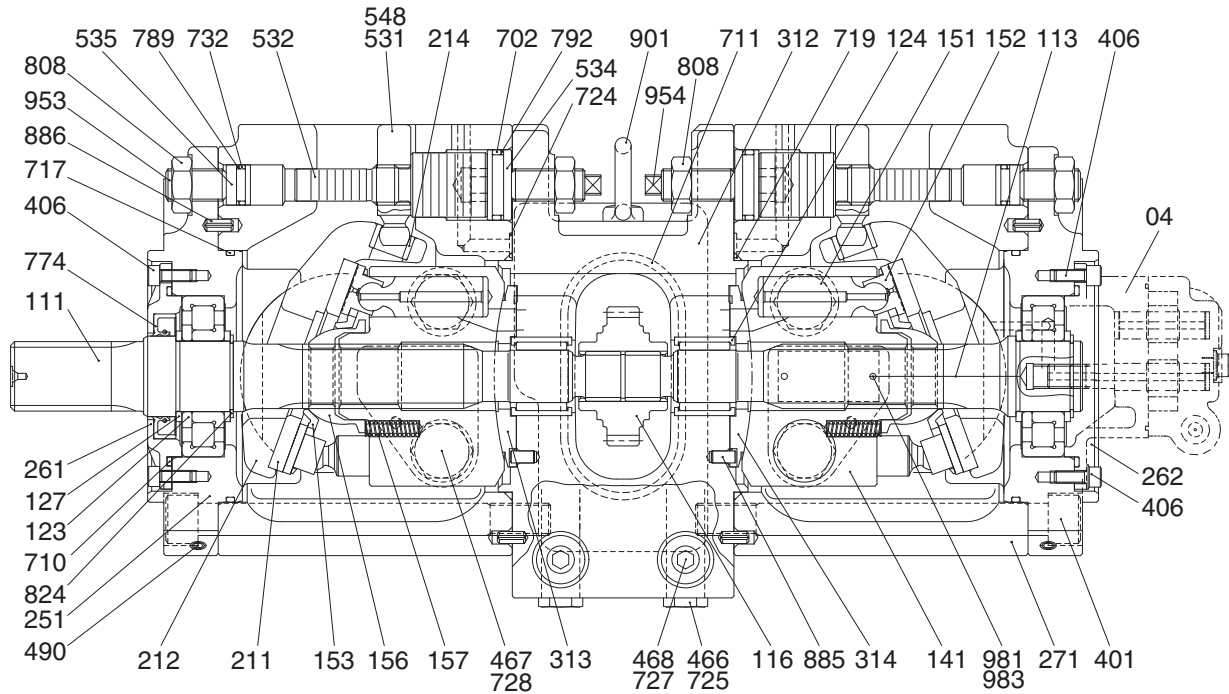

14092MP02

04	Gear pump	312	Valve block	717	O-ring
111	Drive shaft (F)	313	Valve plate (R)	719	O-ring
113	Drive shaft (R)	314	Valve plate (L)	724	O-ring
116	1st Gear	326	Cover	725	O-ring
123	Roller bearing	401	Hexagon socket bolt	727	O-ring
124	Needle bearing	406	Hexagon socket bolt	728	O-ring
127	Bearing spacer	414	Hexagon socket bolt	732	O-ring
141	Cylinder block	466	Plug	774	Oil seal
151	Piston	467	plug	789	Back up ring
152	Shoe	468	Plug	792	Back up ring
153	Set plate	490	Plug	808	Hexagon head nut
156	Bushing	531	Tilting pin	824	Snap ring
157	Cylinder spring	532	Servo piston	885	Pin
211	Shoe plate	534	Stopper (L)	886	Spring pin
212	Swash plate	535	Stopper (S)	901	Eye bolt
251	Support	548	Pin	953	Set screw
261	Seal cover (F)	702	O-ring	954	Set screw
271	Pump casing	710	O-ring	981	Plate
		711	O-ring	983	Pin

2) TOOLS AND TIGHTENING TORQUE

(1) Tools

The tools necessary to disassemble/reassemble the pump are shown in the follow list.

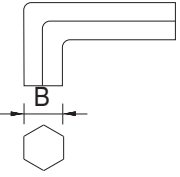
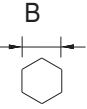
Tool name & size		Part name			
Name	B	Hexagon socket head bolt	PT plug (PT thread)	PO plug (PF thread)	Hexagon socket head setscrew
Allen wrench 	4	M 5	BP-1/16	-	M 8
	5	M 6	BP-1/8	-	M10
	6	M 8	BP-1/4	PO-1/4	M12, M14
	8	M10	BP-3/8	PO-3/8	M16, M18
	17	M20, M22	BP-1	PO-1, 1 1/4, 1 1/2	-
Double ring spanner, socket wrench, double (single) open end spanner 	-	Hexagon bolt	Hexagon nut	VP plug (PF thread)	
	19	M12	M12	VP-1/4	
	24	M16	M16	-	
	27	M18	M18	VP-1/2	
	30	M20	M20	-	
	36	-	-	VP-3/4	
Adjustable angle wrench		Medium size, 1 set			
Screw driver		Minus type screw driver, Medium size, 2 sets			
Hammer		Plastic hammer, 1 set			
Pliers		For snap ring, TSR-160			
Steel bar		Steel bar of key material approx. 10 × 8 × 200			
Torque wrench		Capable of tightening with the specified torques			

(2) Tightening torque

Part name	Bolt size	Torque		Wrench size	
		kgf · m	lbf · ft	in	mm
Hexagon socket head bolt (material : SCM435)	M 5	0.7	5.1	0.16	4
	M 6	1.2	8.7	0.20	5
	M 8	3.0	21.7	0.24	6
	M10	5.8	42.0	0.31	8
	M12	10.0	72.3	0.39	10
	M14	16.0	116	0.47	12
	M16	24.0	174	0.55	14
	M18	34.0	246	0.55	14
PT Plug (material : S45C) ※Wind a seal tape 1 1/2 to 2 turns round the plug	PT1/16	0.7	5.1	0.16	4
	PT 1/8	1.05	7.59	0.20	5
	PT 1/4	1.75	12.7	0.24	6
	PT 3/8	3.5	25.3	0.31	8
	PT 1/2	5.0	36.2	0.39	10
PF Plug (material : S45C)	PF 1/4	3.0	21.7	0.24	6
	PF 1/2	10.0	72.3	0.39	10
	PF 3/4	15.0	109	0.55	14
	PF 1	19.0	137	0.67	17
	PF 1 1/4	27.0	195	0.67	17
	PF 1 1/2	28.0	203	0.67	17

3) DISASSEMBLY

- (1) Select place suitable to disassembling.
 - ※ Select clean place.
 - ※ Spread rubber sheet, cloth or so on on overhaul workbench top to prevent parts from being damaged.
- (2) Remove dust, rust, etc, from pump surfaces with cleaning oil or so on.
- (3) Remove drain port plug (468) and let oil out of pump casing (front and rear pump).
- (4) Remove hexagon socket head bolts (412, 413) and remove regulator.

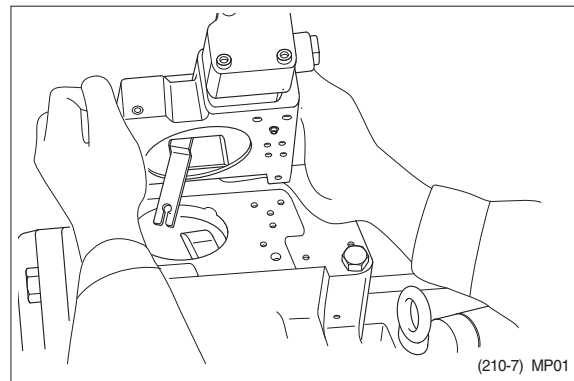

- (5) Loosen hexagon socket head bolts (401) which tighten swash plate support (251), pump casing (271) and valve block (312).
 - ※ If gear pump and so on are fitted to rear face of pump, remove them before starting this work.

- (6) Place pump horizontally on workbench with its regulator-fitting surface down and separate pump casing (271) from valve block (312).
 - ※ Before bringing this surface down, spread rubber sheet on workbench without fail to prevent this surface from being damaged.

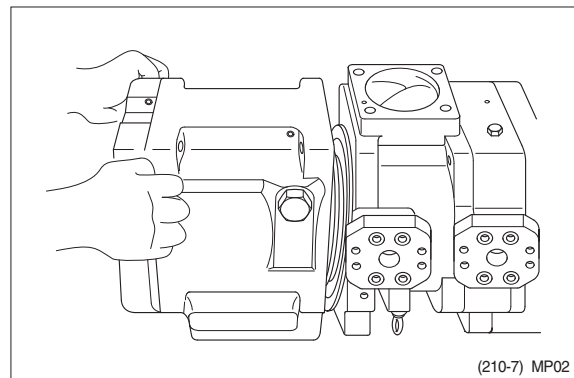

(7) Pull cylinder block (141) out of pump casing (271) straightly over drive shaft (111). Pull out also pistons (151), set plate (153), spherical bush (156) and cylinder springs (157) simultaneously.

※ Take care not to damage sliding surfaces of cylinder, spherical bushing, shoes, swash plate, etc.

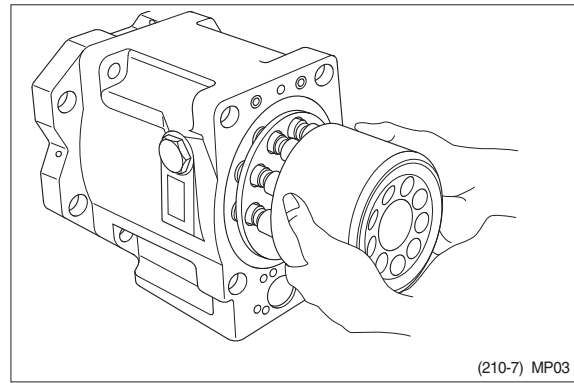

(8) Remove hexagon socket head bolts (406) and then seal cover (F, 261).

※ Fit bolt into pulling out tapped hole of seal cover (F), and cover can be removed easily.

※ Since oil seal is fitted on seal cover (F), take care not to damage it in removing cover.

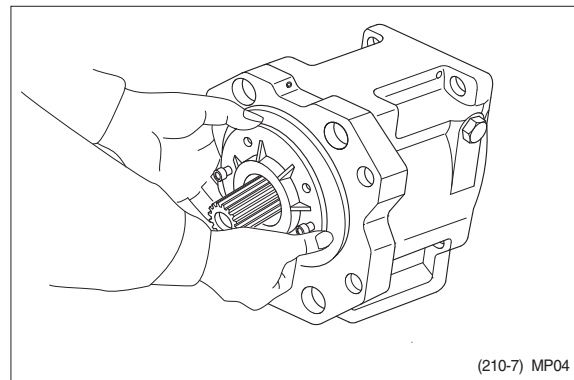

(9) Remove hexagon socket head bolts (408) and then seal cover (R, 262).

In case fitting a gear pump, first, remove gear pump.

(10) Tapping lightly fitting flange section of swash plate support (251) on its pump casing side, separate swash plate support from pump casing.

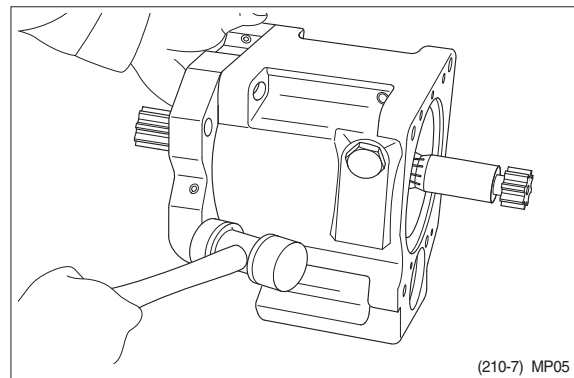

(11) Remove shoe plate (211) and swash plate (212) from pump casing (271).

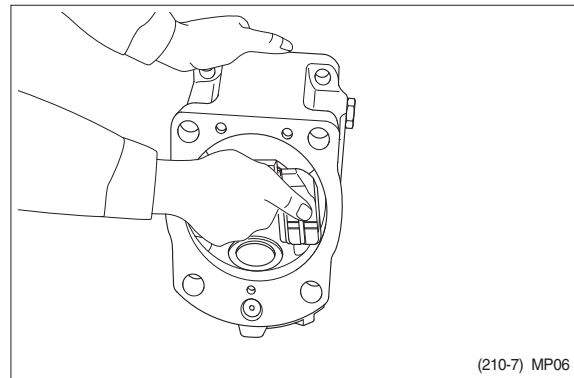

- (12) Tapping lightly shaft ends of drive shafts (111, 113) with plastic hammer, take out drive shafts from swash plate supports.

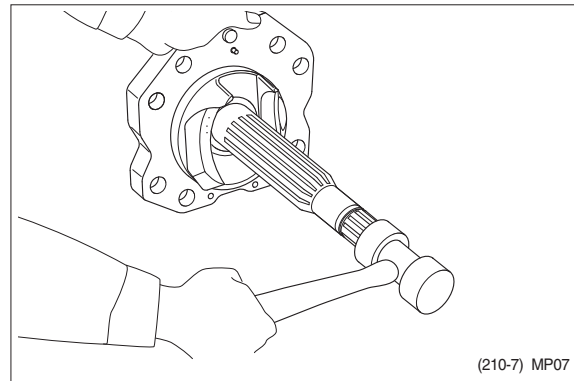

- (13) Remove valve plates (313, 314) from valve block (312).
※ These may be removed in work (6).

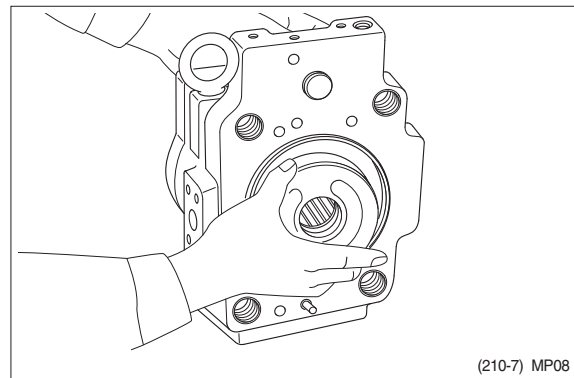

- (14) If necessary, remove stopper (L, 534), stopper (S, 535), servo piston (532) and tilting pin (531) from pump casing (271), and needle bearing (124) and splined coupling (114) from valve block (312).
- ※ In removing tilting pin, use a protector to prevent pin head from being damaged.
 - ※ Since loctite is applied to fitting areas of tilting pin and servo piston, take care not to damage servo piston.
 - ※ Do not remove needle bearing as far as possible, except when it is considered to be out of its life span.
 - ※ Do not loosen hexagon nuts of valve block and swash plate support.
If loosened, flow setting will be changed.

4) ASSEMBLY

(1) For reassembling reverse the disassembling procedures, paying attention to the following items.

- ① Do not fail to repair the parts damaged during disassembling, and prepare replacement parts in advance.
- ② Clean each part fully with cleaning oil and dry it with compressed air.
- ③ Do not fail to apply clean working oil to sliding sections, bearings, etc. before assembling them.
- ④ In principle, replace seal parts, such as O-rings, oil seals, etc.
- ⑤ For fitting bolts, plug, etc., prepare a torque wrench or so on, and tighten them with torques shown in page 8-11, 12.
- ⑥ For the double-pump, take care not to mix up parts of the front pump with those of the rear pump.

(2) Fit swash plate support (251) to pump casing (271), tapping the former lightly with a hammer.

- ※ After servo piston, tilting pin, stopper (L) and stopper (S) are removed, fit them soon to pump casing in advance for reassembling.
- ※ In tightening servo piston and tilting pin, use a protector to prevent tilting pin head and feedback pin from being damaged. In addition, apply loctite (Medium strength) to their threaded sections.

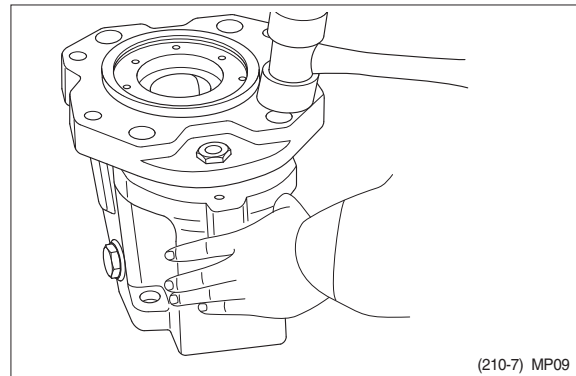

(210-7) MP09

(3) Place pump casing with its regulator fitting surface down, fit tilting bush of swash plate to tilting pin (531) and fit swash plate (212) to swash plate support (251) correctly.

- ※ Confirm with fingers of both hands that swash plate can be removed smoothly.
- ※ Apply grease to sliding sections of swash plate and swash plate support, and drive shaft can be fitted easily.

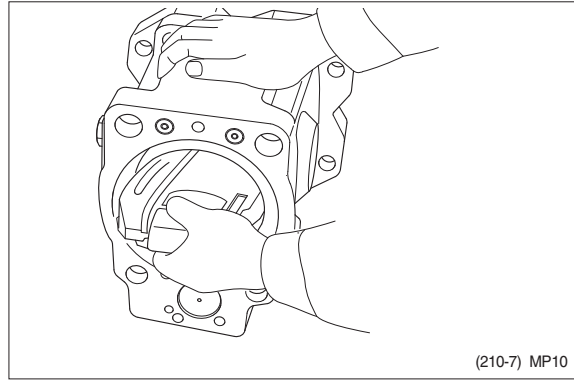

(4) To swash plate support (251), fit drive shaft (111) set with bearing (123), bearing spacer (127) and snap ring (824).

- ※ Do not tap drive shaft with hammer or so on.
- ※ Assemble them into support, tapping outer race of bearing lightly with plastic hammer.
- Fit them fully, using steel bar or so on.

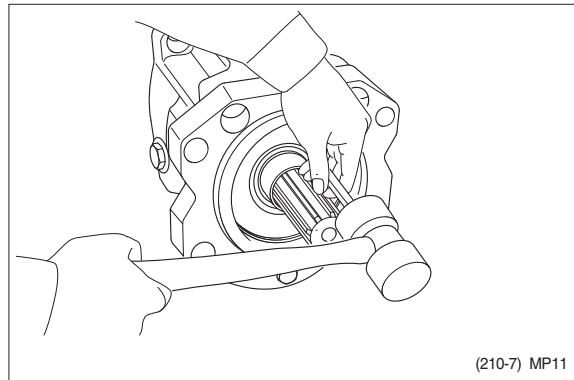

(5) Assemble seal cover (F, 261) to pump casing (271) and fix it with hexagon socket head bolts (406).

- ※ Apply grease lightly to oil seal in seal cover (F).
- ※ Assemble oil seal, taking full care not to damage it.
- ※ For tandem type pump, fit rear cover (263) and seal cover (262) similarly.

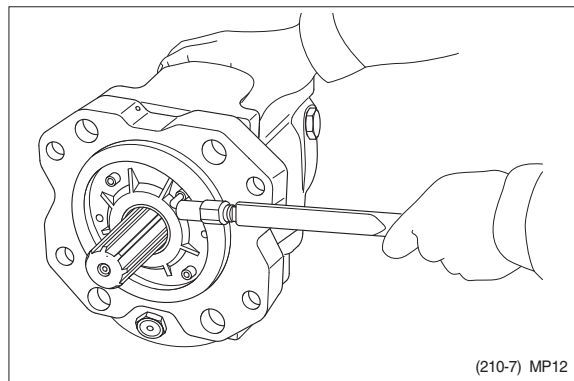

(6) Assemble piston cylinder subassembly [cylinder block (141), piston subassembly (151, 152), set plate (153), spherical bush (156), spacer (158) and cylinder spring (157)] .
Fit spline phases of retainer and cylinder.
Then, insert piston cylinder subassembly into pump casing.

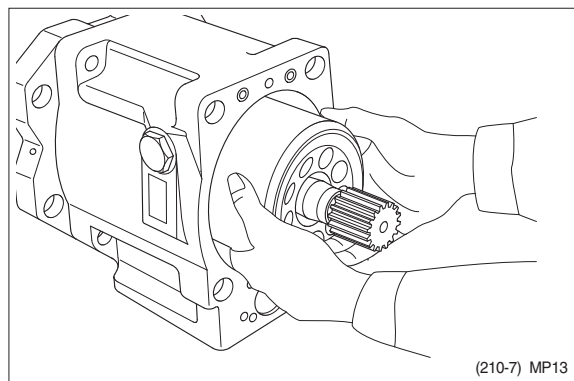

- (7) Fit valve plate (313) to valve block (312), entering pin into pin hole.
 ※ Take care not to mistake suction / delivery directions of valve plate.

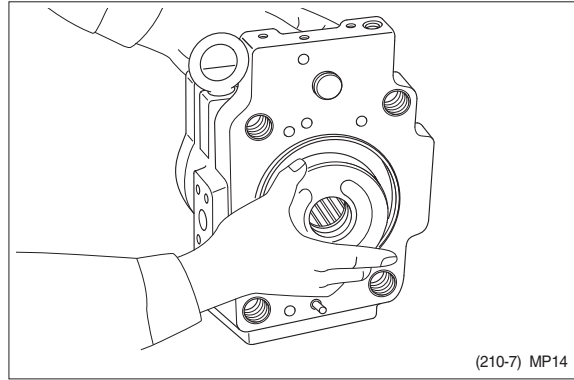

- (8) Fit valve block (312) to pump casing (271) and tighten hexagon socket head bolts (401).
 ※ At first assemble this at rear pump side, and this work will be easy.
 ※ Take care not to mistake direction of valve block.
 ※ Clockwise rotation (Viewed from input shaft side) - Fit block with regulator up and with delivery flange left, viewed from front side.
 ※ Counter clockwise rotation (Viewed from input shaft side) - Fit block with delivery flange right, viewed from front side.

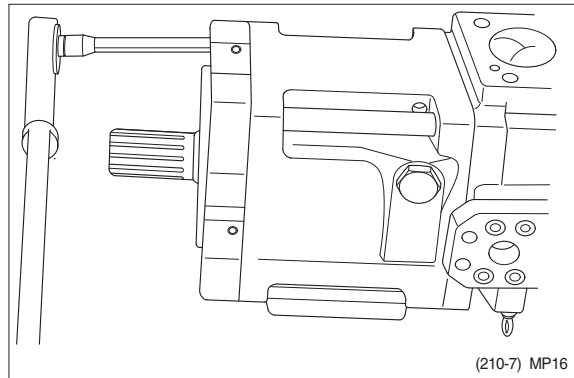

- (9) Putting feedback pin of tilting pin into feedback lever of regulator, fit regulator and tighten hexagon socket head bolts (412, 413).
 ※ Take care not to mistake regulator of front pump for that of rear pump.

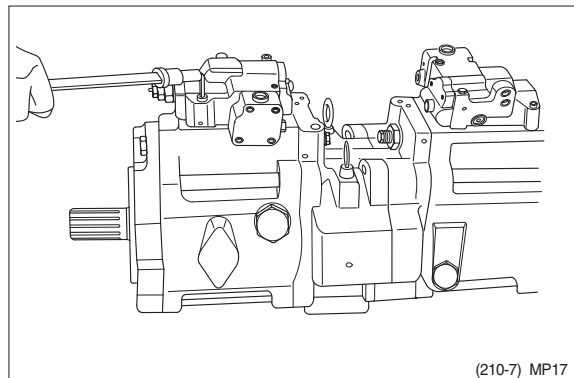

- (10) Fit drain port plug (468).
 This is the end of reassembling procedures.

3. REGULATOR

1) STRUCTURE (1/2)

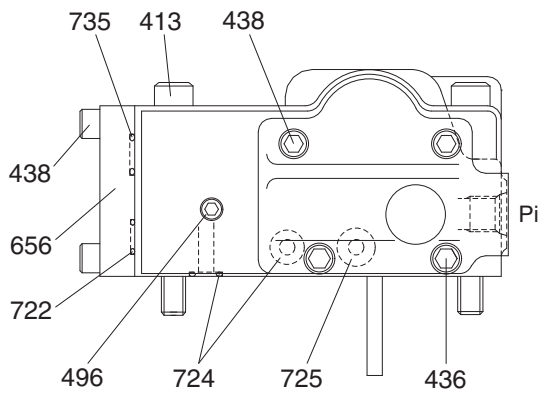
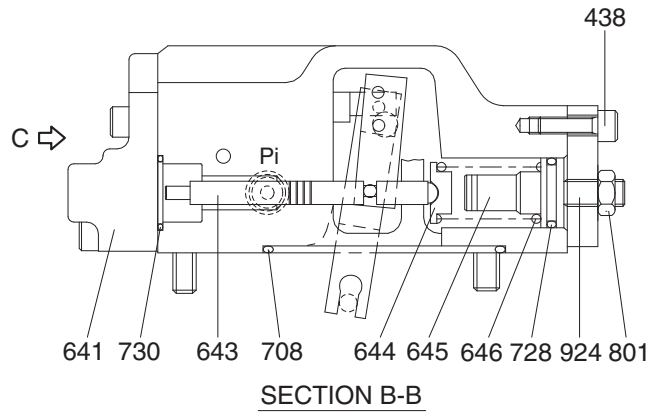
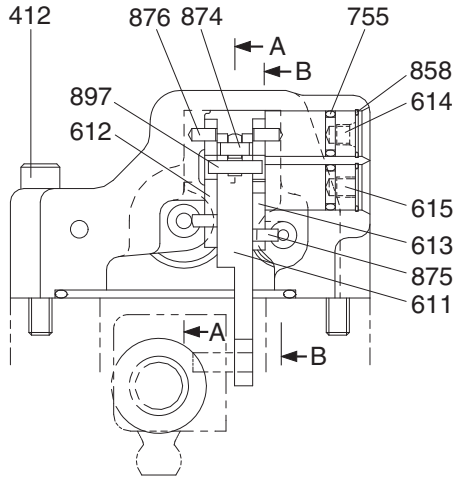

VIEW C (FRONT)

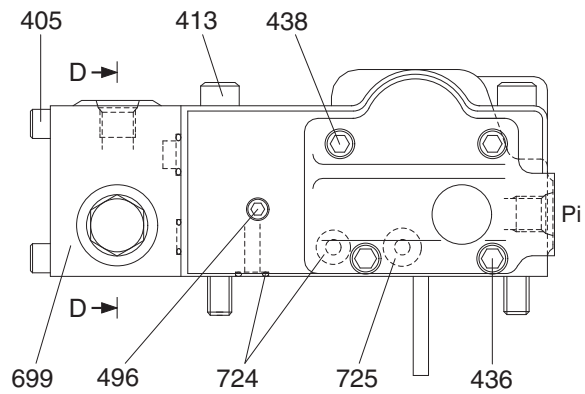

VIEW C (REAR)

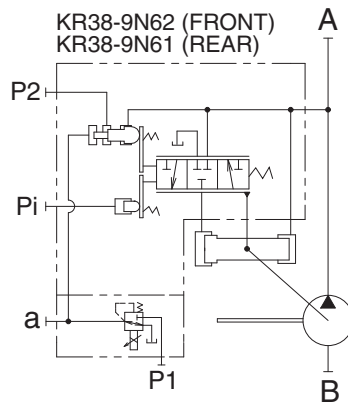
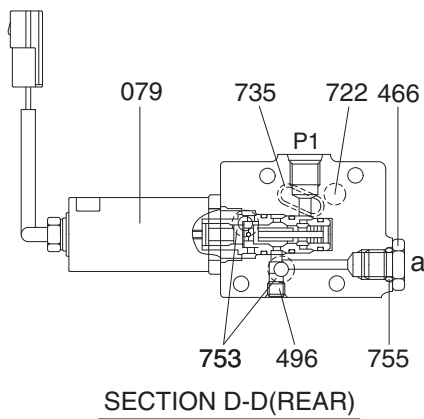

REGULATOR (2/2)

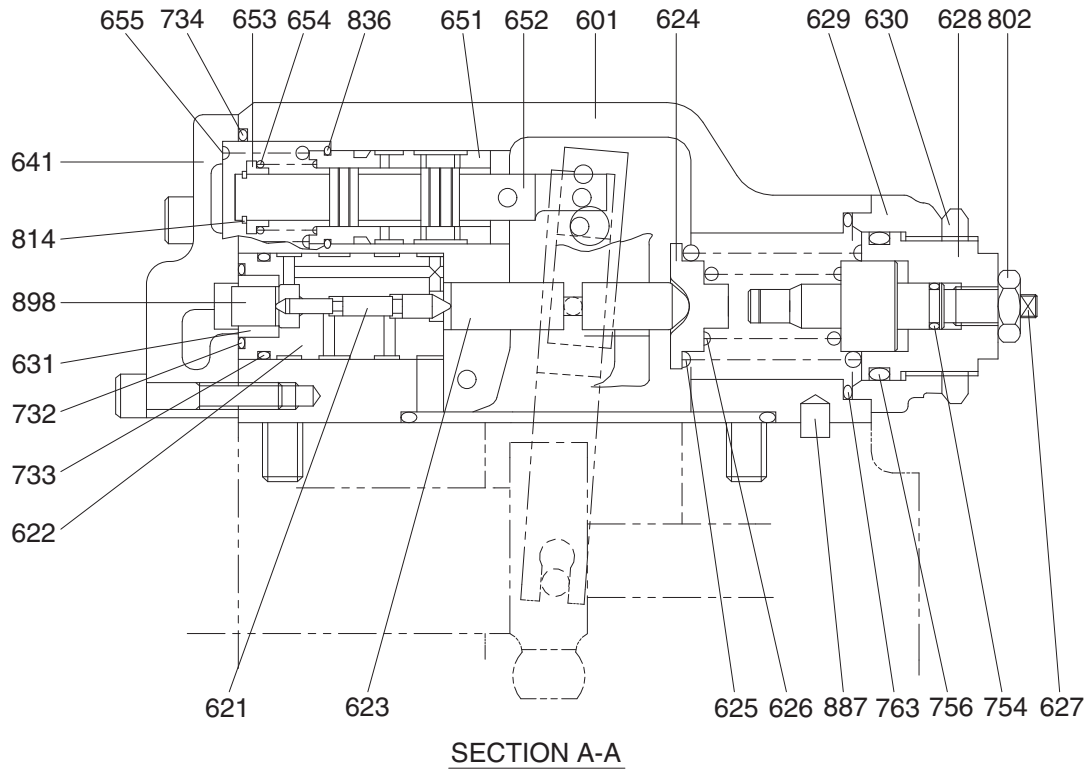



14092MP05

079	EPPR valve assembly	629	Cover (C)	733	O-ring
405	Hexagon socket screw	630	Lock nut	734	O-ring
412	Hexagon socket screw	631	Sleeve, Pf	735	O-ring
413	Hexagon socket screw	641	Pilot cover	753	O-ring
436	Hexagon socket screw	643	Pilot piston	754	O-ring
438	Hexagon socket screw	644	Spring seat (Q)	755	O-ring
466	Plug	645	Adjust stem (Q)	756	O-ring
496	Plug	646	Pilot spring	763	O-ring
601	Casing	651	Sleeve	801	Nut
611	Feed back lever	652	Spool	802	Nut
612	Lever (1)	653	Spring seat	814	Snap ring
613	Lever (2)	654	Return spring	836	Snap ring
614	Fulcrum plug	655	Set spring	858	Snap ring
615	Adjust plug	656	Block cover	874	Pin
621	Compensator piston	699	Valve casing	875	Pin
622	Piston case	708	O-ring	876	Pin
623	Compensator rod	722	O-ring	887	Pin
624	Spring seat (C)	724	O-ring	897	Pin
625	Outer spring	725	O-ring	898	Pin
626	Inner spring	728	O-ring	924	Set screw
627	Adjust stem (C)	730	O-ring		
628	Adjust screw (C)	732	O-ring		

2) TOOLS AND TIGHTENING TORQUE

(1) Tools

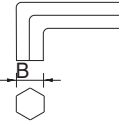
The tools necessary to disassemble/reassemble the pump are shown in the follow list.

Tool name & size		Part name			
Name	B	Hexagon socket head bolt	PT plug (PT thread)	PO plug (PF thread)	Hexagon socket head setscrew
Allen wrench 	4	M5	BP-1/16	-	M 8
	5	M6	BP-1/8	-	M10
	6	M8	BP-1/4	PO-1/4	M12, M14
Double ring spanner, socket wrench, double (single) open end spanner 	-	Hexagon head bolt	Hexagon nut	VP plug (PF thread)	
	6	M 8	M 8	-	
Adjustable angle wrench		Small size, Max 36 mm			
Screw driver		Minus type screw driver, Medium size, 2 sets			
Hammer		Plastic hammer, 1 set			
Pliers		For snap ring, TSR-160			
Steel bar		4 × 100 mm			
Torque wrench		Capable of tightening with the specified torques			
Pincers		-			
Bolt		M4, Length : 50 mm			

(2) Tightening torque

Part name	Bolt size	Torque		Wrench size	
		kgf · m	lbf · ft	in	mm
Hexagon socket head bolt (material : SCM435)	M 5	0.7	5.1	0.16	4
	M 6	1.2	8.7	0.20	5
	M 8	3.0	21.7	0.24	6
	M10	5.8	42.0	0.31	8
	M12	10.0	72.3	0.39	10
	M14	16.0	116	0.47	12
	M16	24.0	174	0.55	14
	M18	34.0	246	0.55	14
	M20	44.0	318	0.67	17
PT Plug (material : S45C) ※Wind a seal tape 1 1/2 to 2 turns round the plug	PT1/16	0.7	5.1	0.16	4
	PT 1/8	1.05	7.59	0.20	5
	PT 1/4	1.75	12.7	0.24	6
	PT 3/8	3.5	25.3	0.31	8
	PT 1/2	5.0	36.2	0.39	10
PF Plug (material : S35C)	PF 1/4	3.0	21.7	0.24	6
	PF 1/2	10.0	72.3	0.39	10
	PF 3/4	15.0	109	0.55	14
	PF 1	19.0	137	0.67	17
	PF 1 1/4	27.0	195	0.67	17
	PF 1 1/2	28.0	203	0.67	17

3) DISASSEMBLY

Since the regulator consists of small precision finished parts, disassembly and assembly are rather complicated.

For this reason, replacement of a regulator assembly is recommended, unless there is a special reason, but in case disassembly is necessary for an unavoidable reason, read through this manual to the end before starting disassembly.

- (1) Choose a place for disassembly.
 - ※ Choose a clean place.
 - ※ Spread rubber sheet, cloth, or so on on top of work-bench to prevent parts from being damaged.
- (2) Remove dust, rust, etc. from surfaces of regulator with clean oil.
- (3) Remove hexagon socket head screw (412, 413) and remove regulator main body from pump main body.
 - ※ Take care not to lose O-ring.

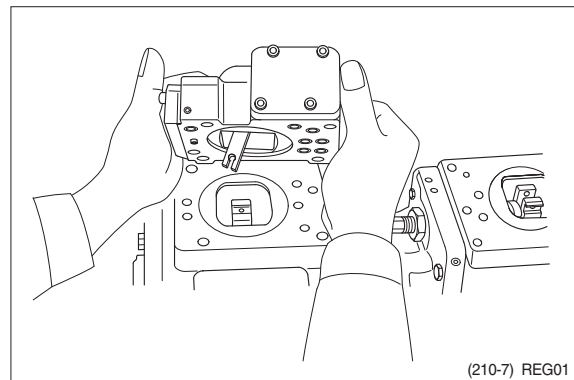

- (4) Remove hexagon socket head screw (438) and remove cover (C,629)
 - ※ Cover (C) is fitted with adjusting screw (C, 628), adjusting ring (C, 627), lock nut (630), hexagon nut (801) and adjusting screw (924).
 - ※ Do not loosen these screws and nuts. If they are loosened, adjusted pressure-flow setting will vary.

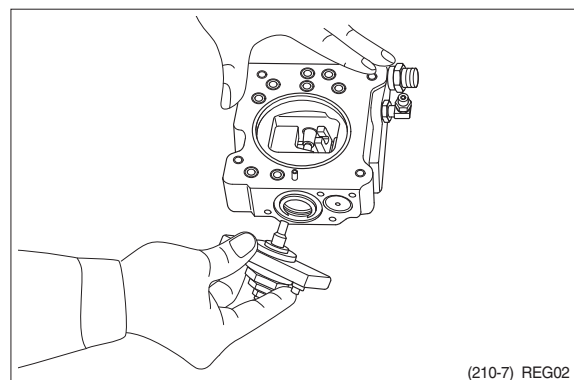

- (5) After removing cover (C, 629) subassembly, take out outer spring (625), inner spring (626) and spring seat (C, 624) from compensating section.
Then draw out adjusting ring (Q, 645), pilot spring (646) and spring seat (644) from pilot section.
- ※ Adjusting ring (Q,645) can easily be drawn out with M4 bolt.

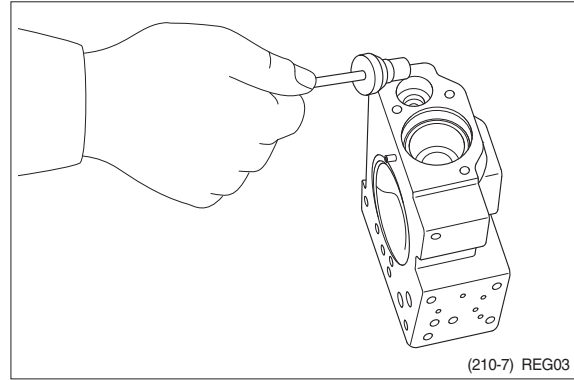

- (6) Remove hexagon socket head screws (436, 438) and remove pilot cover (641).
After removing pilot cover, take out set spring (655) from pilot section.

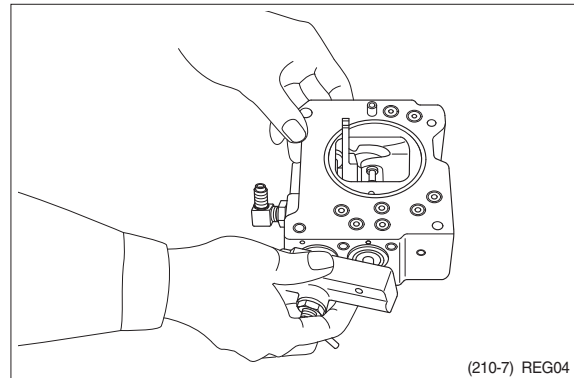

- (7) Remove snap ring (814) and take out spring seat (653), return spring (654) and sleeve (651).
- ※ Sleeve (651) is fitted with snap ring (836).
 - ※ When removing snap ring (814), return spring (654) may pop out. Take care not to lose it.

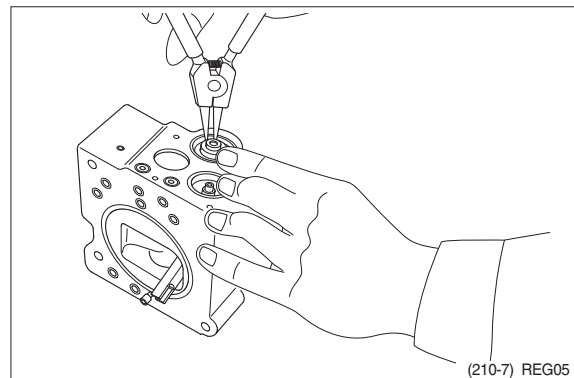

- (8) Remove locking ring (858) and take out fulcrum plug (614) and adjusting plug (615).
- ※ Fulcrum plug (614) and adjusting plug (615) can easily be taken out with M6 bolt.

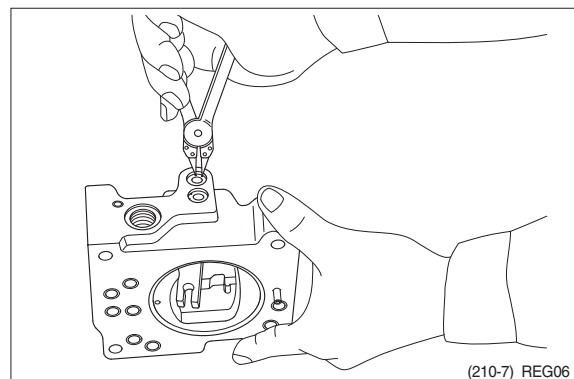

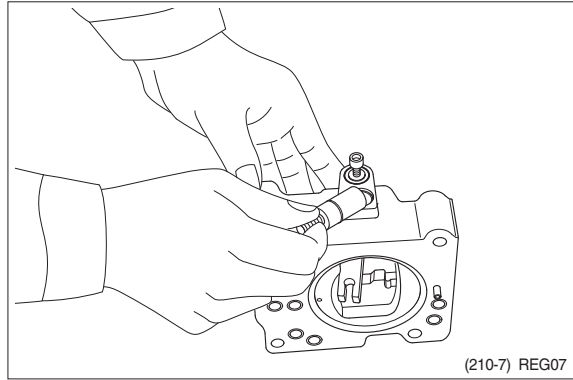

- (9) Remove lever (2, 613). Do not draw out pin (875).
※ Work will be promoted by using pincers or so on.

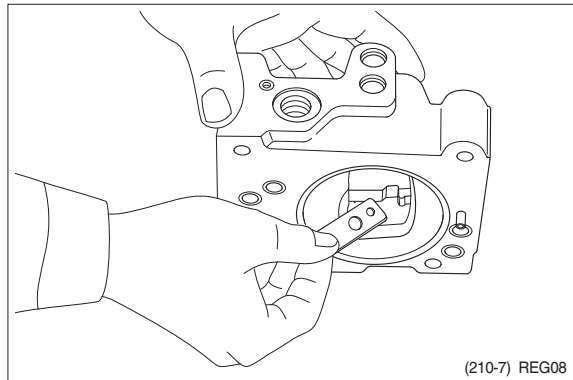

- (10) Draw out pin (874) and remove feedback lever (611).
Push out pin (874, 4 mm in dia.) from above with slender steel bar so that it may not interfere with lever (1, 612).

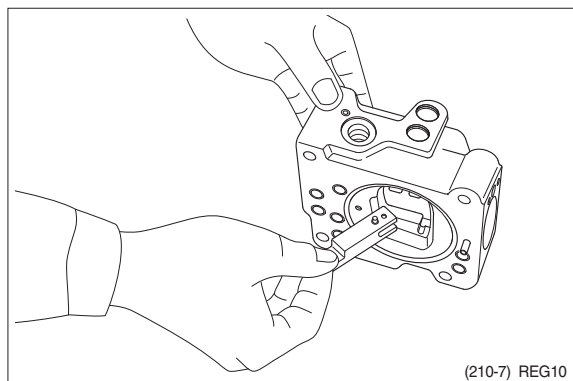
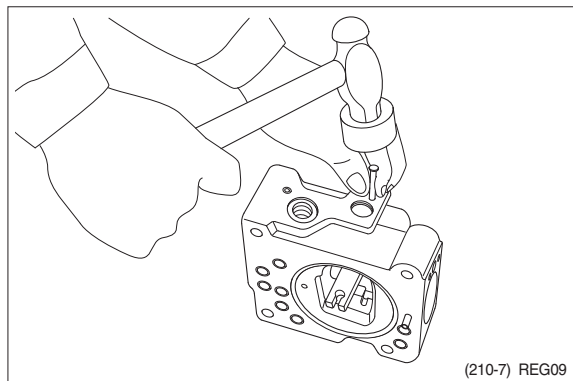

- (11) Remove lever 1 (612). Do not draw out pin (875).
 - (12) Draw out pilot piston (643) and spool (652).
 - (13) Draw out piston case (622), compensating piston (621) and compensating rod (623).
- ※ Piston case (622) can be taken out by pushing compensating rod (623) at opposite side of piston case.

This completes disassembly.

4) ASSEMBLY

(1) For assembly, reverse disassembly procedures, but pay attention to the following items.

- ① Always repair parts that were scored at disassembly.
- ② Get replacement parts ready beforehand.
Mixing of foreign matter will cause malfunction.
Therefore, wash parts well with cleaning oil, let them dry with jet air and handle them in clean place.
- ③ Always tighten bolts, plugs, etc. to their specified torques.
- ④ Do not fail to coat sliding surfaces with clean hydraulic oil before assembly.
- ⑤ Replace seals such as O-ring with new ones as a rule.

(2) Put compensating rod (623) into compensating hole of casing (601).

(3) Put pin force-fitted in lever 1 (612) into groove of compensating rod and fit lever 1 to pin force-fitted in casing.

(4) Fit spool (652) and sleeve (651) into hole in spool of casing.

- ※ Confirm that spool and sleeve slide smoothly in casing without binding.
- ※ Pay attention to orientation of spool.

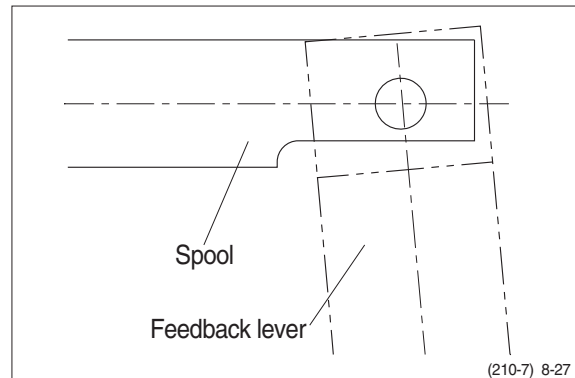

- (5) Fit feedback lever (611), matching its pin hole with pin hole in spool.
Then insert pin (874).
- ※ Insert pin in feedback lever a little to ease operation.
 - ※ Take care not to mistake direction of feedback lever.

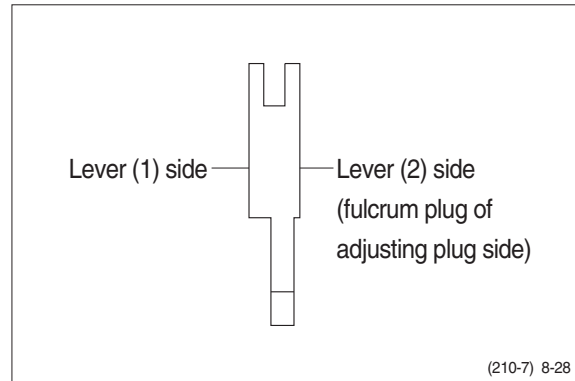

- (6) Put pilot piston (643) into pilot hole of casing.
- ※ Confirm that pilot piston slides smoothly without binding.
- (7) Put pin force-fitted in lever 2 (613) into groove of pilot piston.
Then fix lever 2.

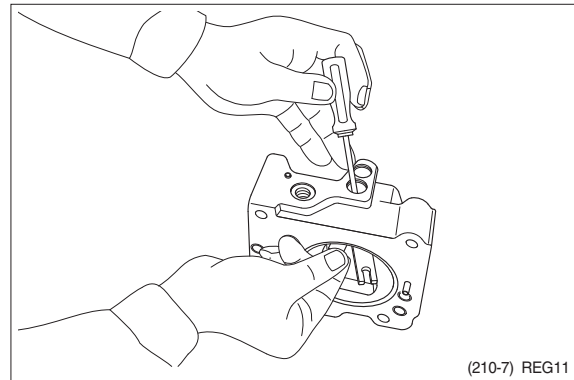

- (8) Fit fulcrum plug (614) so that pin force-fitted in fulcrum plug (614) can be put into pin hole of lever 2.
Then fix locking ring (858).
- (9) Insert adjusting plug (615) and fit locking ring.
- ※ Take care not to mistake inserting holes for fulcrum plug and adjusting plug.
- At this point in time move feedback lever to confirm that it has no large play and is free from binding.

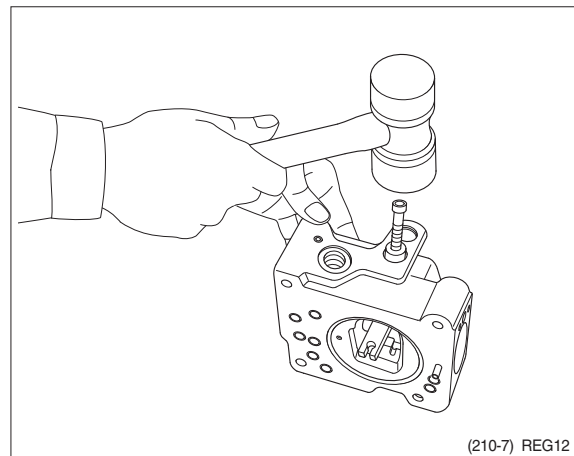

- (10) Fit return spring (654) and spring seat (653) into spool hole and attach snap ring (814).

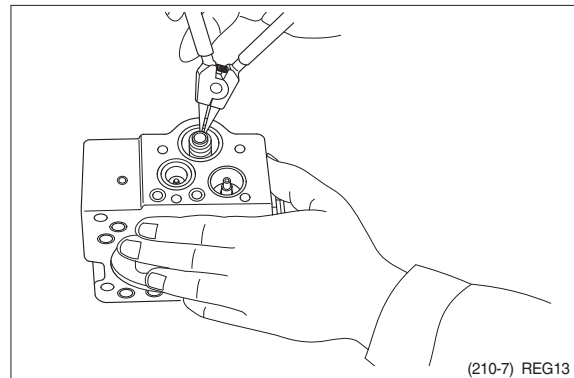

- (11) Fit set spring (655) to spool hole and put compensating piston (621) and piston case (622) into compensating hole.

Fit pilot cover (641) and tighten it with hexagonal socket head screws (436, 438).

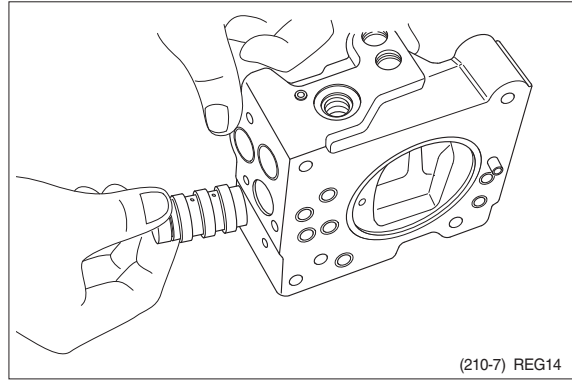

- (12) Put spring seat (644), pilot spring (646) and adjusting ring (Q, 645) into pilot hole. Then fix spring seat (624), inner spring (626) and outer spring (625) into compensating hole.

※ When fitting spring seat, take care not to mistake direction of spring seat.

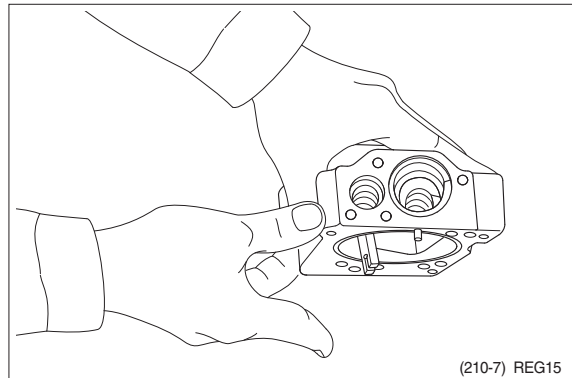

- (13) Install cover (C, 629) fitted with adjusting screws (628), adjusting ring (C, 627), lock nut (630), hexagon nut (801) and adjusting screw (924).

Then tighten them with hexagonal socket head screws (438).

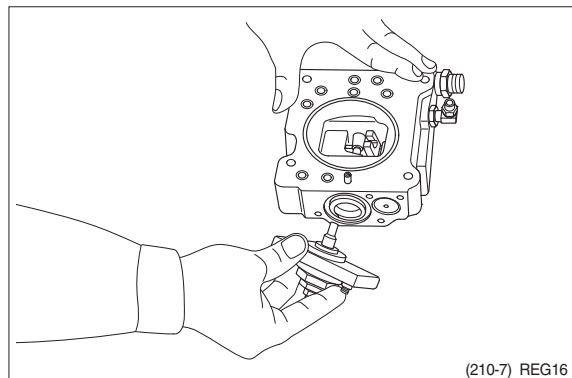

This completes assembly.

GROUP 4 MAIN CONTROL VALVE

1. REMOVAL AND INSTALL OF MOTOR

1) REMOVAL

- (1) Lower the work equipment to the ground and stop the engine.
- (2) Operate the control levers and pedals several times to release the remaining pressure in the hydraulic piping.
- (3) Loosen the breather slowly to release the pressure inside the hydraulic tank.
- ▲ **Escaping fluid under pressure can penetrate the skin causing serious injury.**
- ※ When pipes and hoses are disconnected, the oil inside the piping will flow out, so catch it in oil pan.
- (4) Remove the wirings for the pressure sensor and so on.
- (5) Remove bolts and disconnect pipe.
- (6) Disconnect pilot line hoses.
- (7) Disconnect pilot piping.
- (8) Sling the control valve assembly and remove the control valve mounting bolt and bracket.
 - Weight : 140kg (310lb)
 - Tightening torque : $12.8 \pm 3.0 \text{ kgf} \cdot \text{m}$
($92.6 \pm 21.7 \text{ lbf} \cdot \text{ft}$)

- (9) Remove the control valve assembly.
When removing the control valve assembly, check that all the piping have been disconnected.

2) INSTALL

- (1) Carry out installation in the reverse order to removal.
- (2) Bleed the air from below items.
 - ① Cylinder (Boom, arm, bucket)
 - ② Swing motor
 - ③ Travel motor※ See each item removal and install.
- (3) Confirm the hydraulic oil level and recheck the hydraulic oil leak or not.

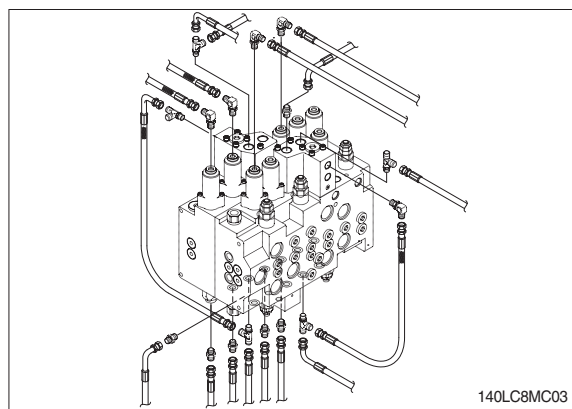
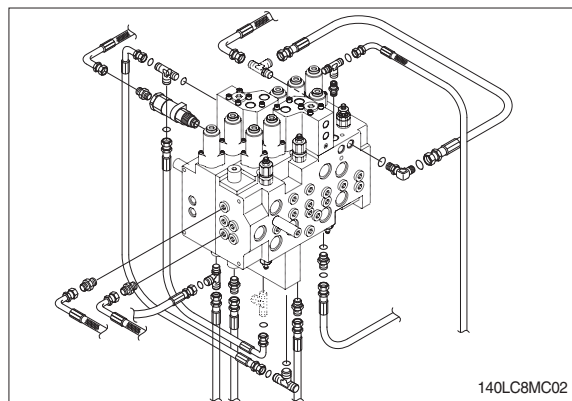
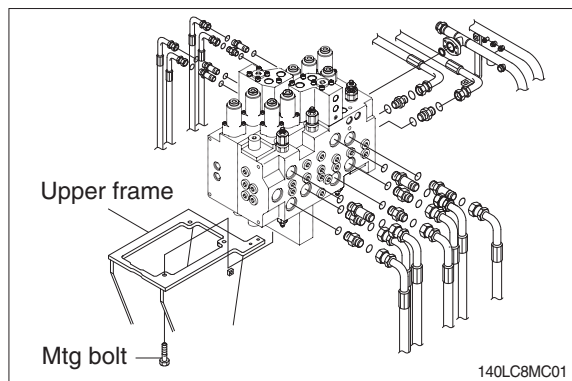

2. STRUCTURE (1/4)

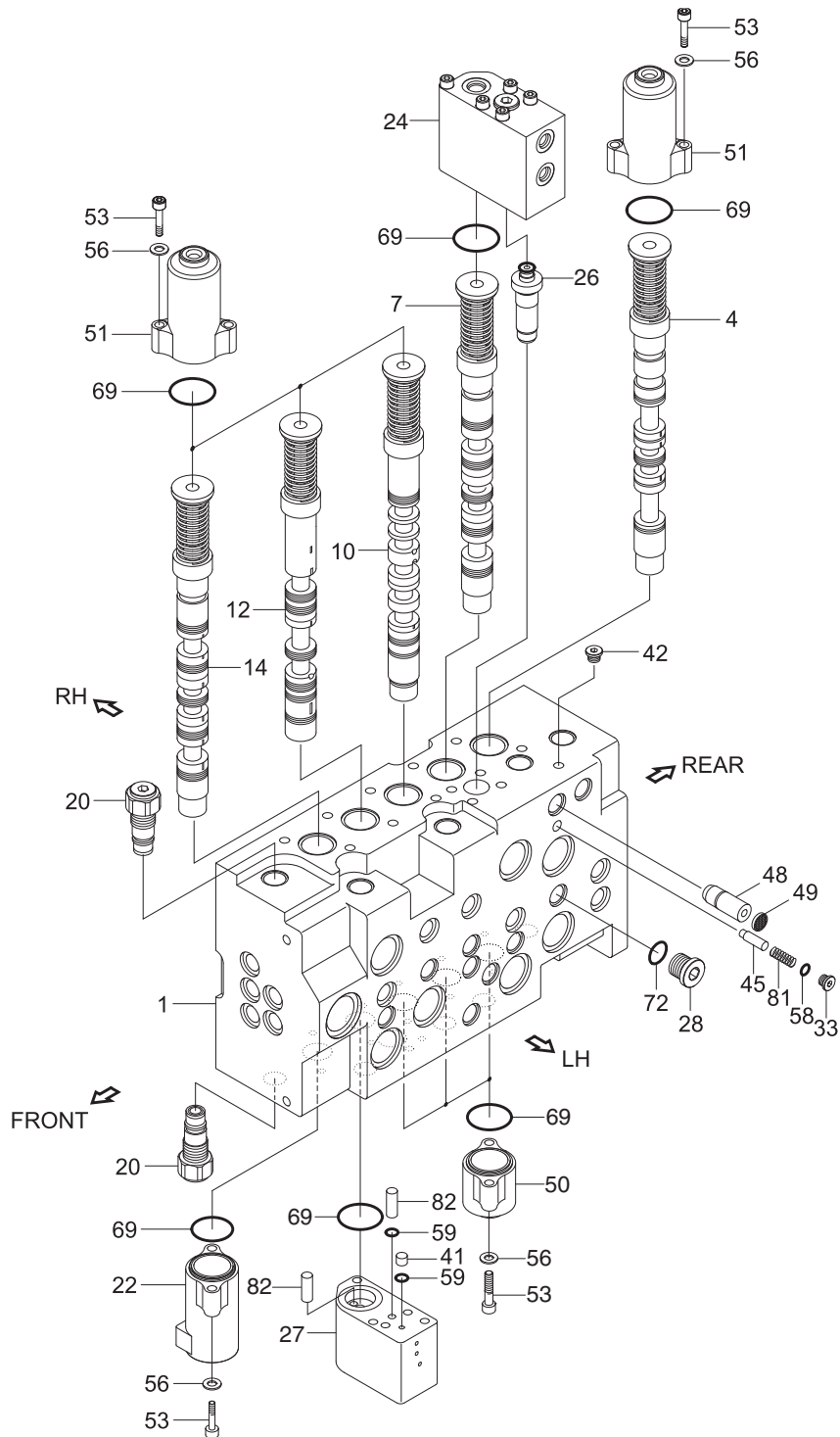

140L8MC04

1	Housing-P1	27	Regeneration block	53	Socket head bolt
4	Spool assy-travel(LH)	28	Plug	56	Plain washer
7	Spool assy-boom 1	33	Plug	58	O-ring
10	Spool assy-arm 2	41	Orifice plug	59	O-ring
12	Spool assy-arm regen	42	Plug	69	O-ring
14	Spool assy-bucket	45	Signal poppet	72	O-ring
20	Nega con relief valve	48	Signal orifice	81	Check spring
22	Bucket stroke limiter	49	Coin type filter	82	Regeneration pin
24	Holding valve kit A1	50	Pilot A cap		
26	Lock valve kit B	51	Pilot B1 cap		

STRUCTURE (2/4)

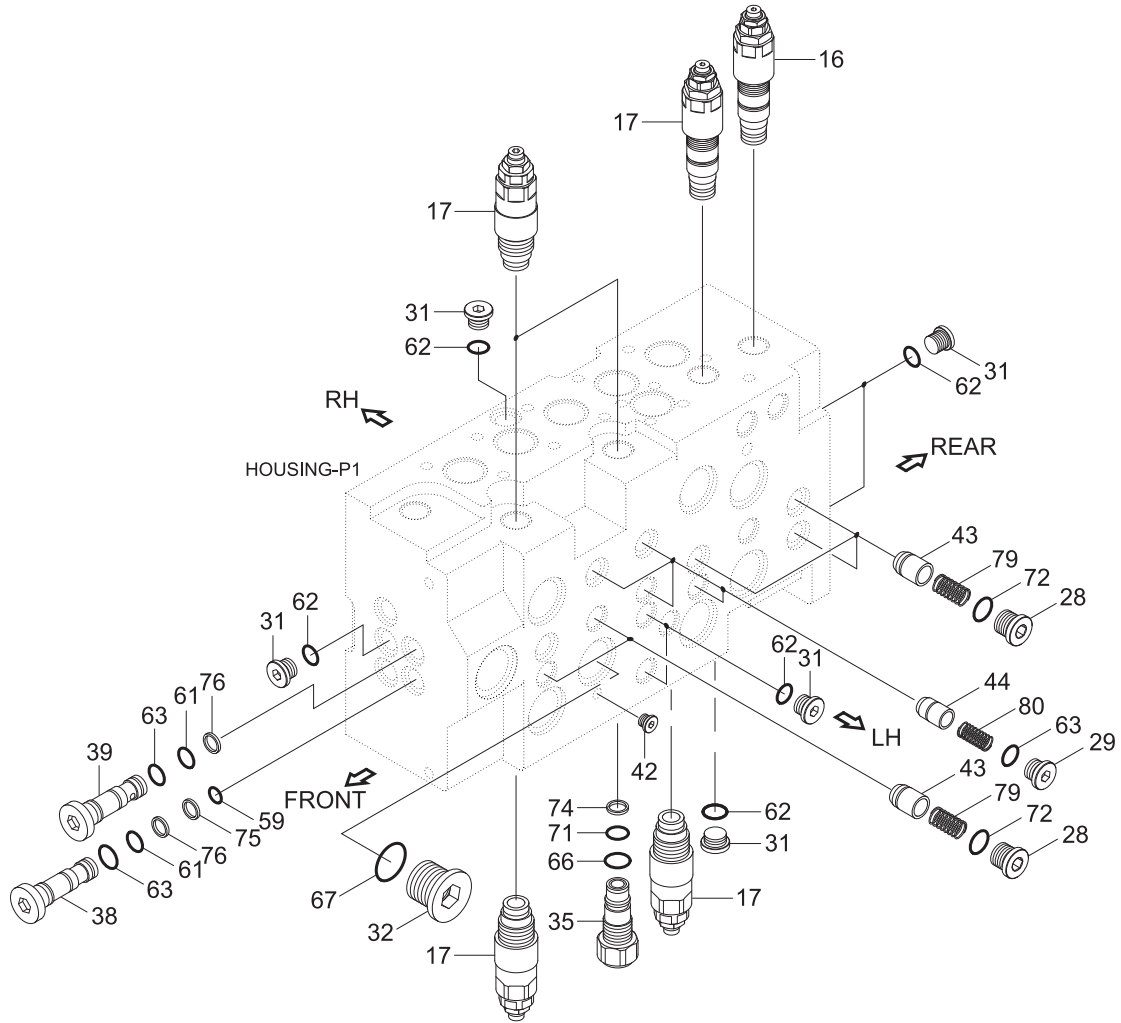

140L8MC05

- 16 Main relief valve
- 17 Overload relief valve
- 28 Plug
- 29 Plug
- 31 Plug
- 32 Plug
- 35 Plug
- 38 Plug
- 39 Plug

- 42 Plug
- 43 Poppet 1
- 44 Poppet 2
- 59 O-ring
- 61 O-ring
- 62 O-ring
- 63 O-ring
- 66 O-ring
- 67 O-ring

- 71 O-ring
- 72 O-ring
- 74 Back up ring
- 75 Back up ring
- 76 Back up ring
- 79 Spring
- 80 Spring

STRUCTURE (3/4)

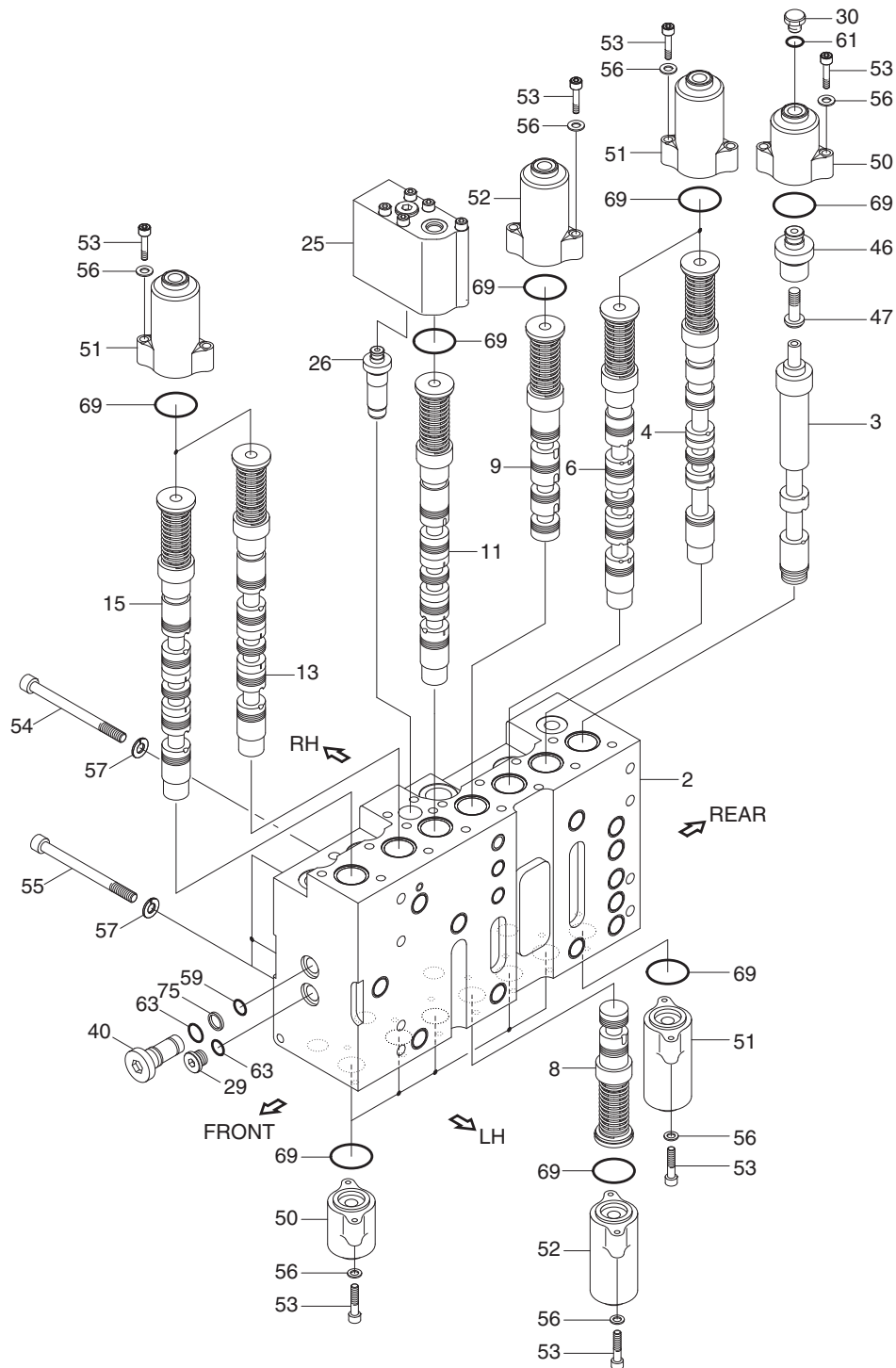

140L8MC06

- | | | | | | |
|----|----------------------------|----|-------------------|----|------------------|
| 2 | Housing-P2 | 26 | Lock valve kit B | 54 | Socket head bolt |
| 3 | Spool assy-straight travel | 29 | Plug | 55 | Socket head bolt |
| 4 | Spool assy-travel(RH) | 30 | Plug | 56 | Plain washer |
| 6 | Spool assy-swing | 40 | Plug | 57 | Spring washer |
| 8 | Spool assy-swing priority | 46 | T/straight sleeve | 59 | O-ring |
| 9 | Spool assy-boom 2 | 47 | T/straight piston | 61 | O-ring |
| 11 | Spool assy-arm 1 | 50 | Pilot A cap | 63 | O-ring |
| 13 | Spool assy-option B | 51 | Pilot B1 cap | 69 | O-ring |
| 15 | Spool assy-option C | 52 | Pilot B2 cap | 75 | Back up ring |
| 25 | Arm 1 holding valve kit A2 | 53 | Socket head bolt | | |

STRUCTURE (4/4)

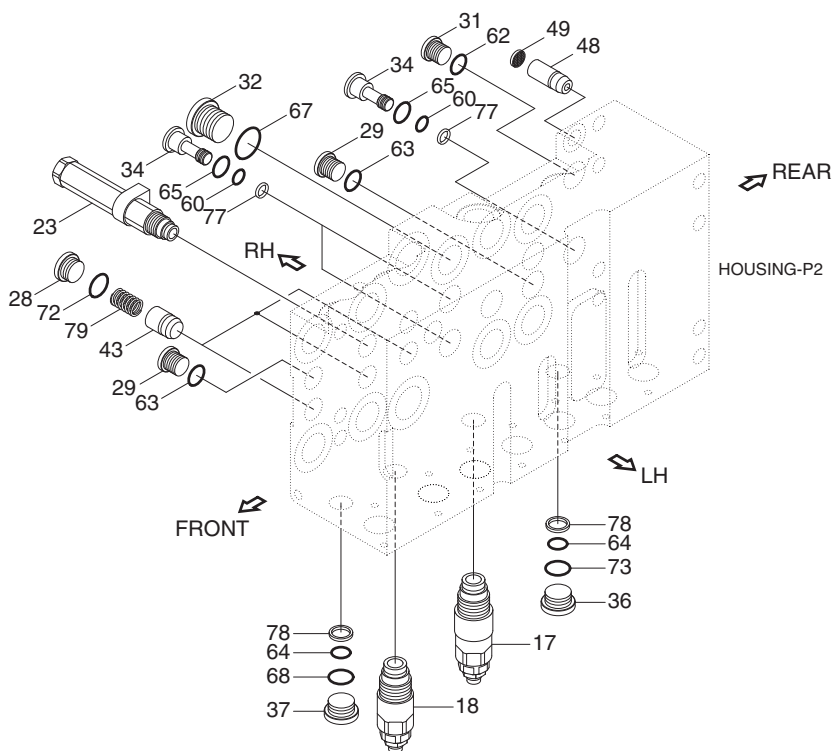
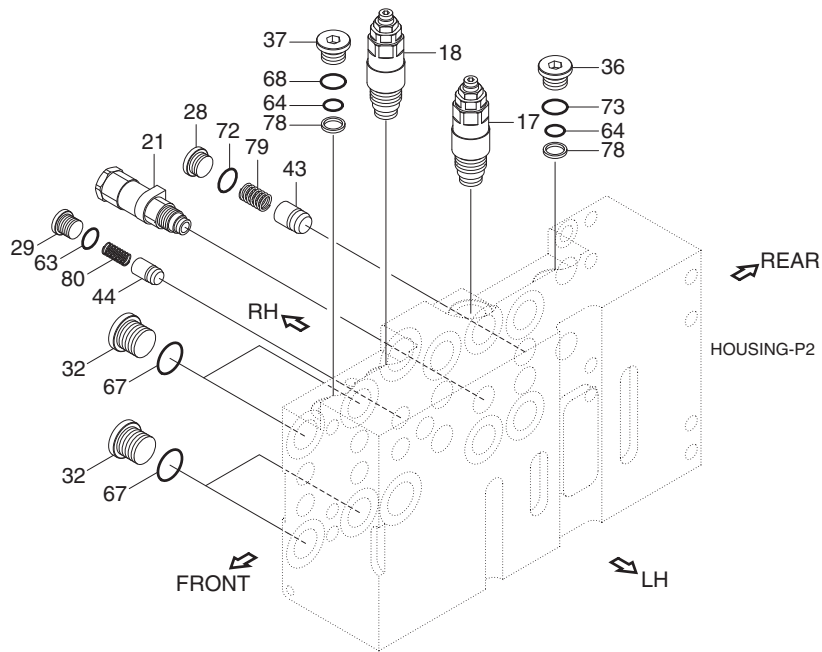

- | | | | | | |
|----|-----------------------|----|------------------|----|--------------|
| 17 | Overload relief valve | 37 | Plug | 67 | O-ring |
| 18 | Overload relief valve | 43 | Poppet 1 | 68 | O-ring |
| 21 | Swing logic valve | 44 | Poppet 2 | 72 | O-ring |
| 23 | ON/OFF valve-option | 48 | Signal orifice | 73 | O-ring |
| 28 | Plug | 49 | Coin type filter | 77 | Back up ring |
| 29 | Plug | 60 | O-ring | 78 | Back up ring |
| 31 | Plug | 62 | O-ring | 79 | Spring |
| 32 | Plug | 63 | O-ring | 80 | Spring |
| 34 | Plug | 64 | O-ring | | |
| 36 | Plug | 65 | O-ring | | |

140L8MC07

3. DISASSEMBLY AND ASSEMBLY

1) GENERAL PRECAUTIONS

- (1) All hydraulic components are manufactured to a high precision. Consequently, before disassembling and assembling them, it is essential to select an especially clean place.
- (2) In handling a control valve, pay full attention to prevent dust, sand, etc. from entering into it.
- (3) When a control valve is to be removed from the machine, apply caps and masking seals to all ports. Before disassembling the valve, recheck that these caps and masking seals are fitted completely, and then clean the outside of the assembly. Use a proper bench for working. Spread paper or a rubber mat on the bench, and disassemble the valve on it.
- (4) Support the body section carefully when carrying or transferring the control valve. Do not lift by the exposed spool, end cover section etc.
- (5) After disassembling and assembling of the component it is desired to carry out various tests (for the relief characteristics, leakage, flow resistance, etc.), but hydraulic test equipment is necessary for these tests. Therefore, even when its disassembling can be carried out technically, do not disassemble such components that cannot be tested, adjusted, and so on. Additionally one should always prepare clean cleaning oil, hydraulic oil, grease, etc. beforehand.

2) TOOLS

Before disassembling the control valve, prepare the following tools beforehand.

Name of tool	Quantity	Size (mm)
Vice mounted on bench (soft jaws)	1 unit	
Hexagon wrench	Each 1 piece	5, 6, 10, 12 and 14
Socket wrench	Each 1 piece	27 and 32
Spanner	Each 1 piece	32 (main relief valve, overload relief valve, negative relief valve) 26 (holding valve)

3) DISASSEMBLY

(1) Disassembly of spools without holding valve (travel right, travel left)

- ① Loosen hexagon socket head bolts with washer.
(hexagon wrench : 5 mm)
 - ② Remove the pilot cover.
 - ※ Pay attention not to lose the O-ring under the pilot cover.
 - ③ Remove the spool assembly from the body by hand slightly.
- ※ When extracting each spool from its body, pay attention not to damage the body.
 - ※ When extracting each spool assembly, it must be extracted from spring side only.
 - ※ When any abnormal parts are found, replace it with completely new spool assembly.
 - ※ When disassembled, tag the components for identification so that they can be reassembled correctly.

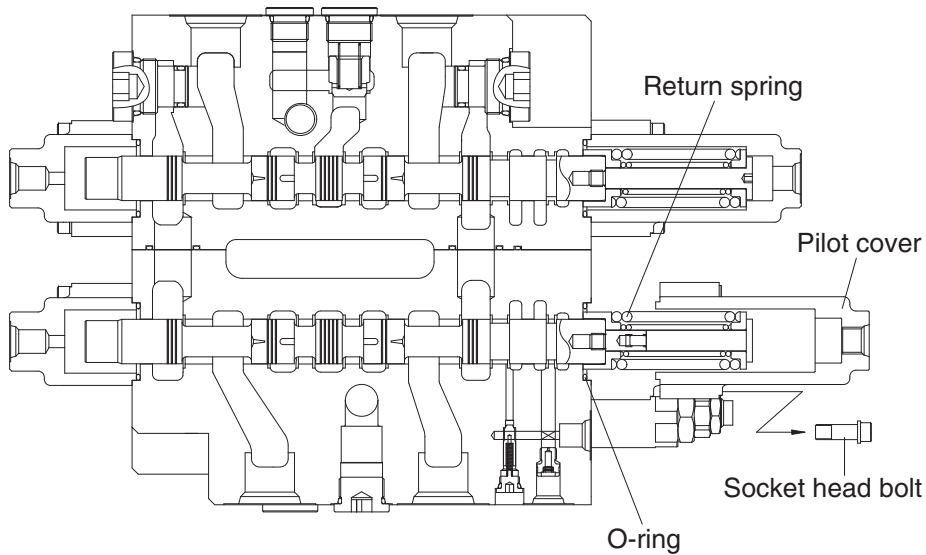

14098MC10

(2) Disassembly of spools with holding valve (boom 1, Arm 1 spool)

- ① Loosen hexagon socket head bolts with washer.
(hexagon wrench : 5 mm)
- ② Remove the pilot cover with internal parts.
 - ※ Pay attention not to lose the O-ring and the poppet under the pilot cover.
 - ※ Pay attention not to damage the "piston A" under pilot cover.
- ③ Remove the spool assembly from the body by hand slightly.
 - ※ When extracting each spool from its body, pay attention not to damage the body.
 - ※ When extracting each spool assembly, it must be extracted from spring side only.
 - ※ When any abnormal parts are found, replace it with completely new spool assembly.
 - ※ When disassembled, tag the components for identification so that they can be reassembled correctly.

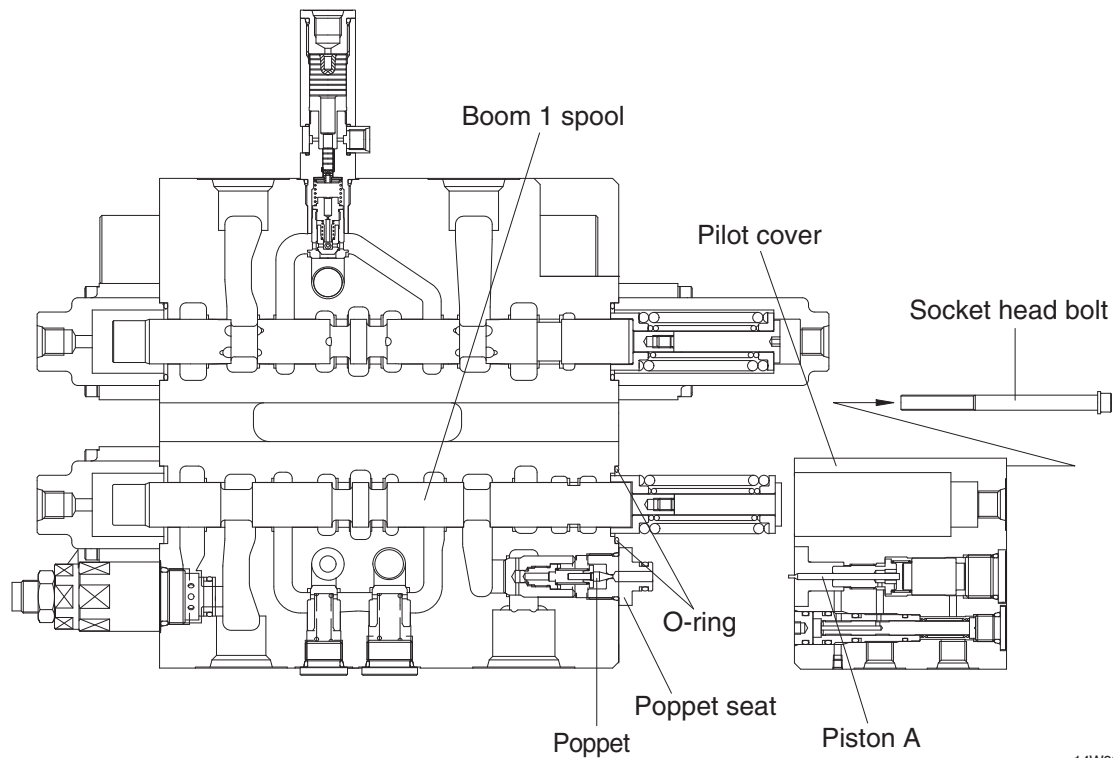

14W98MC11

(3) Disassembly of the holding valve

- ① Remove the pilot cover with the holding valve as described on previous page.
 - ※ Do not disassemble internal parts of the pilot cover.
- ② Loosen the poppet seat and remove the poppet, spring seat, spring and check.
(spanner : 26 mm)
 - ※ Pay attention not to lose the poppet.
 - ※ Do not disassemble internal parts of the check.

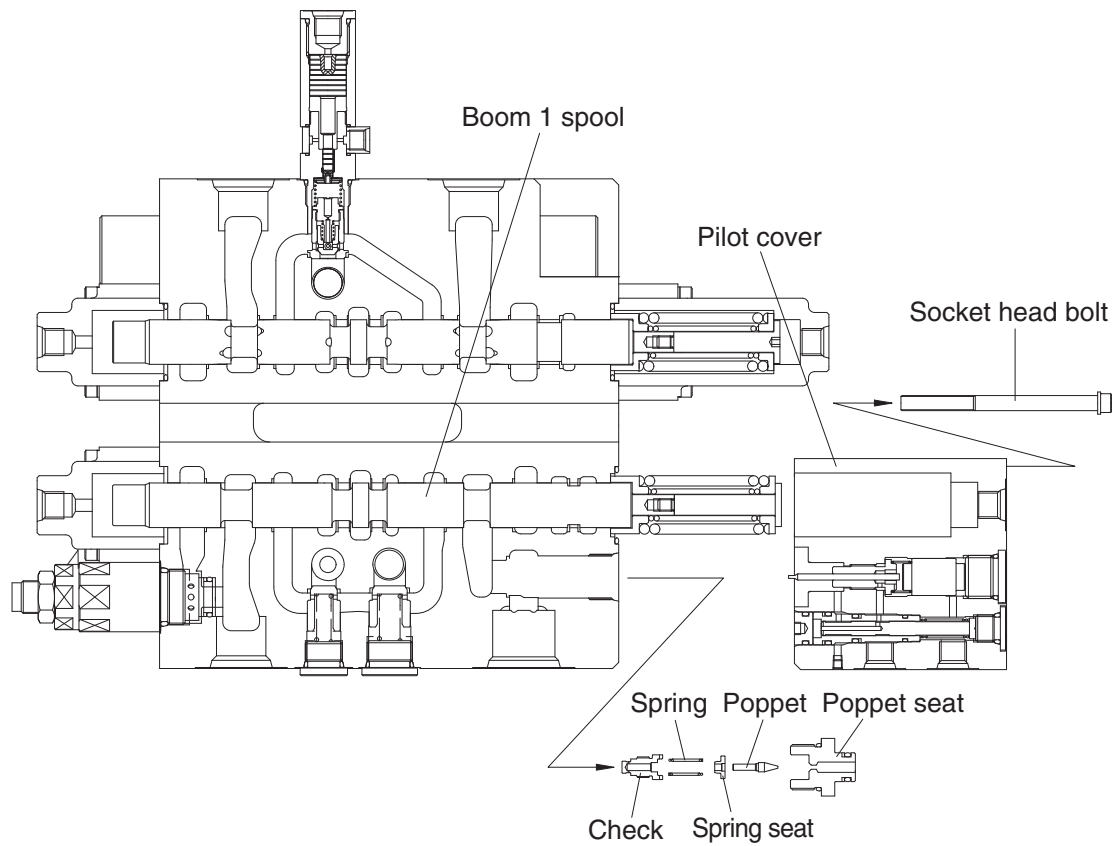

14W98MC12

(4) Disassembly of the load check valve and the negative relief valve

- ① The load check valve
 - a. Fix the body to suitable work bench.
 - ※ Pay attention not to damage the body.
 - b. Loosen the plug (hexagon wrench : 10 mm).
 - c. Remove the spring and the load check valve with pincers or magnet.
- ② The negative relief valve
 - a. Loosen the socket (spanner : 32 mm).
 - b. Remove the spring, spring holder, piston and negative control poppet.

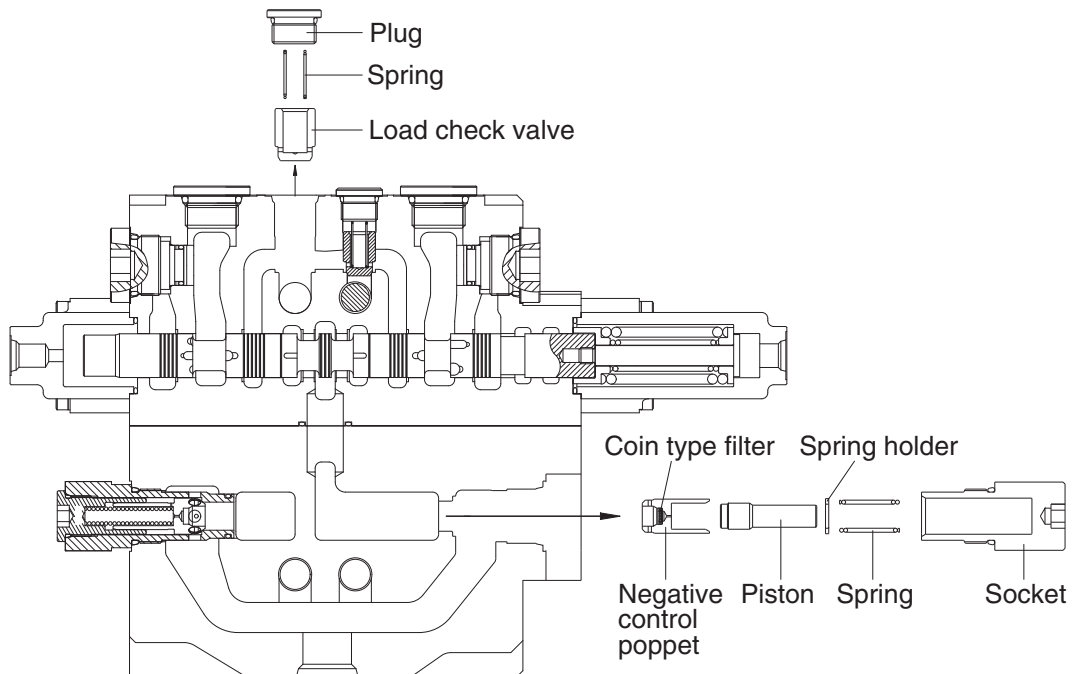

14W98MC13

(5) Disassembly of the main and overload relief valve

① Fix the body to suitable work bench.

② Remove the main relief valve.
(spanner : 32 mm)

③ Remove the overload relief valve.
(spanner : 32 mm)

※ When disassembled, tag the relief valve for identification so that they can be reassembled correctly.

※ Pay attention not to damage seat face.

※ When any abnormal parts are found, replace it with completely new relief valve assembly.

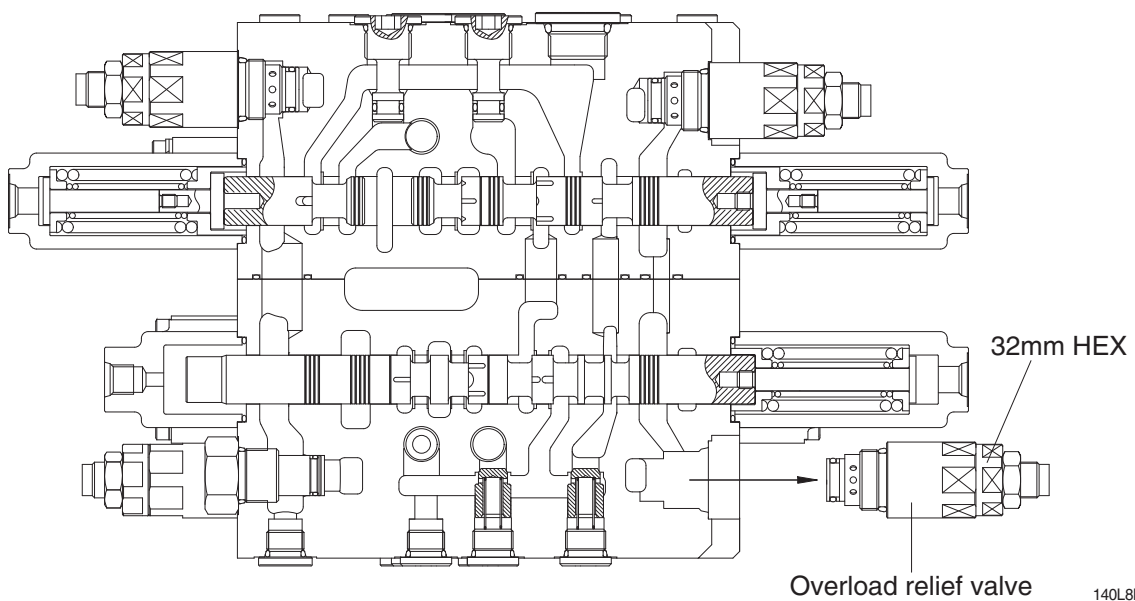
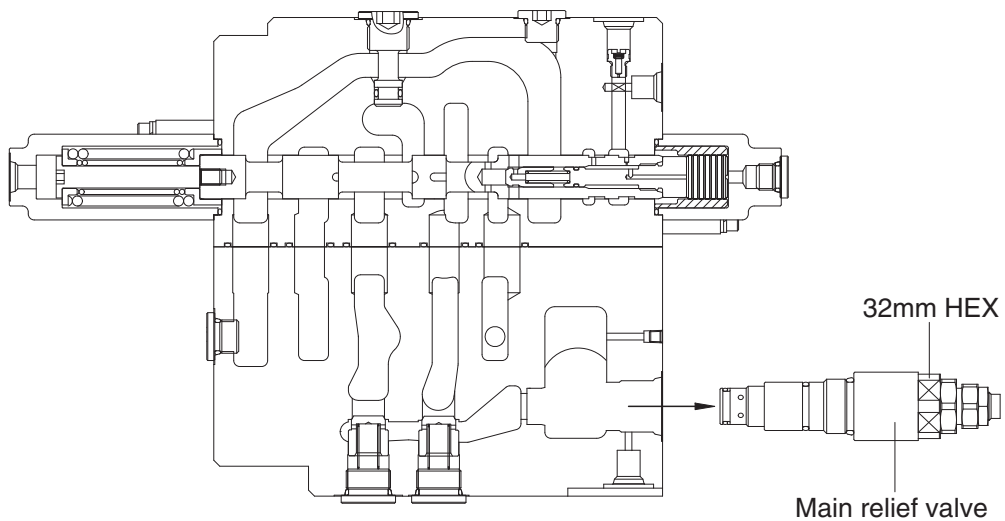

140L8MC14

(6) Inspection after disassembly

Clean all disassembled parts with clean mineral oil fully, and dry them with compressed air. Then, place them on clean papers or cloths for inspection.

① Control valve

- a. Check whole surfaces of all parts for burrs, scratches, notches and other defects.
- b. Confirm that seal groove faces of body and block are smooth and free of dust, dent, rust etc.
- c. Correct dents and damages and check seat faces within the body, if any, by lapping.
※ Pay careful attention not to leave any lapping agent within the body.
- d. Confirm that all sliding and fitting parts can be moved manually and that all grooves and paths are free foreign matter.
- e. If any spring is broken or deformed, replace it with new one.
- f. When a relief valve does not function properly, repair it, following it's the prescribed disassembly and assembly procedures.
- g. Replace all seals and O-rings with new ones.

② Relief valve

- a. Confirm that all seat faces at ends of all poppets and seats are free of defects and show uniform and consistent contact faces.
- b. Confirm manually that main poppet and seat can slide lightly and smoothly.
- c. Confirm that outside face of main poppet and inside face of seat are free from scratches and so on.
- d. Confirm that springs are free from breakage, deformation, and wear.
- e. Confirm that orifices of main poppet and seat section are not clogged with foreign matter.
- f. Replace all O-rings with new ones.
- g. When any light damage is found in above inspections, correct it by lapping.
- h. When any abnormal part is found, replace it with a completely new relief valve assembly.

4) ASSEMBLY

(1) General precaution

- ① In this assembly section, explanation only is shown.
For further understanding, please refer to the figures shown in the previous structure & disassembly section.
- ② Pay close attention to keeping all seals free from handling damage and inspect carefully for damage before using them.
- ③ Apply clean grease or hydraulic oil to the seal so as to ensure it is fully lubricated before assembly.
- ④ Do not stretch seals so much as to deform them permanently.
- ⑤ In fitting O-rings, pay close attention not to roll them into their final position in addition, a twisted O-ring cannot easily untwist itself naturally and could thereby cause inadequate sealing and
- ⑥ thereby both internal and external oil leakage.
Tighten fitting bolts for all sections with a torque wrench adjusted to the respective tightening torque.
- ⑦ Do not reuse removed O-rings and seals.

(2) Load check valve

- ① Assemble the load check valve and spring.
- ② Put O-rings on to plug.
- ③ Tighten plug to the specified torque.
 - Hexagon wrench : 10 mm
 - Tightening torque : 6~7 kgf · m (43.4~50.6 lbf · ft)

(3) Negative control relief valve

- ① Assemble the nega-con poppet, piston, spring holder and spring together into body.
- ② Put O-ring on to plug and tighten the latter to its specified torque.
 - Hexagon wrench : 12 mm
 - Tightening torque : 8~9 kgf · m (57.8~65.1 lbf · ft)

(4) Main relief, overload relief valves

Install main relief valve, overload relief valve into the body and tighten to the specified torque.

Component	Tools	Tightening torque	
		kgf · m	lbf · ft
Main relief valve	Spanner 32 mm	8~9	57.8~65.1
Overload relief valve	Spanner 32 mm	8~9	57.8~65.1

(5) Main spools

- ① Carefully insert the previously assembled spool assemblies into their respective bores within of body.
- ※ Fit spool assemblies into body carefully and slowly. Do not under any circumstances push them forcibly in.

(6) Pilot covers

① Fit spool covers to the non-spring assembly end of the spool, and tighten the hexagonal socket head bolts to the specified torque.

- Hexagon wrench : 5 mm
- Tightening torque : 1.0~1.1 kgf · m (7.2~7.9 lbf · ft)

※ Confirm that O-rings have been fitted.

② Fit spring covers to the spring end for the spools, and tighten hexagon socket head bolts to the specified torque.

- Hexagon wrench : 5mm
- Tightening torque : 1.0~1.1 kgf·m (7.2~7.9 lbf·ft)

※ Confirm that O-rings have been fitted.

(7) Holding valves

① Assemble the check, spring seat and poppet together into body.

② Tighten the poppet seat to the specified torque.

- Spanner : 26 mm
- Tightening torque : 6~7 kgf · m (43.4~50.6 lbf · ft)

③ Fit the "piston A" under pilot cover with internal parts into hole on the poppet seat.

④ Tighten hexagon socket head bolt to specified torque.

- Hexagon wrench : 5mm
- Tightening torque : 1.0~1.1 kgf · m (7.2~7.9 lbf · ft)

GROUP 5 SWING DEVICE

1. REMOVAL AND INSTALL OF MOTOR

1) REMOVAL

- (1) Lower the work equipment to the ground and stop the engine.
- (2) Operate the control levers and pedals several times to release the remaining pressure in the hydraulic piping.
- (3) Loosen the breather slowly to release the pressure inside the hydraulic tank.

▲ Escaping fluid under pressure can penetrate the skin causing serious injury.

※ When pipes and hoses are disconnected, the oil inside the piping will flow out, so catch it in oil pan.

- (4) Disconnect hose assembly (2).
- (5) Disconnect pilot line hoses (3, 4, 5, 6, 7, 8).
- (6) Sling the swing motor assembly (1) and remove the swing motor mounting socket bolts (9).

- Motor device weight : 43 kg (94.8 lb)
- Tightening torque : 17.5 ± 1.8 kgf · m
(127 ± 13.0 lbf · ft)

- (7) Remove the swing motor assembly.
※ When removing the swing motor assembly, check that all the piping have been disconnected.

2) INSTALL

- (1) Carry out installation in the reverse order to removal.
- (2) Bleed the air from the swing motor.
 - ① Remove the air vent plug.
 - ② Pour in hydraulic oil until it overflows from the port.
 - ③ Tighten plug lightly.
 - ④ Start the engine, run at low idling and check oil come out from plug.
 - ⑤ Tighten plug fully.
- (3) Confirm the hydraulic oil level and check the hydraulic oil leak or not.

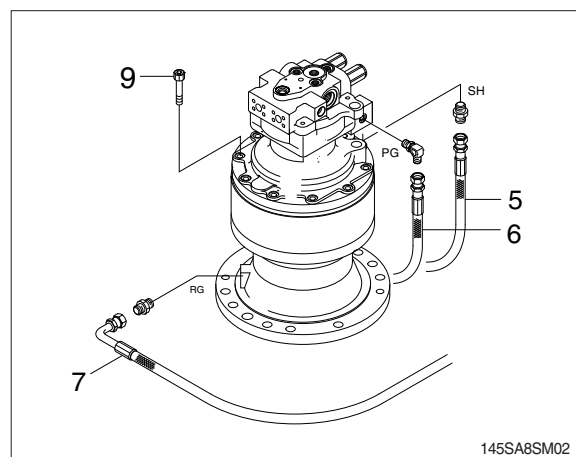
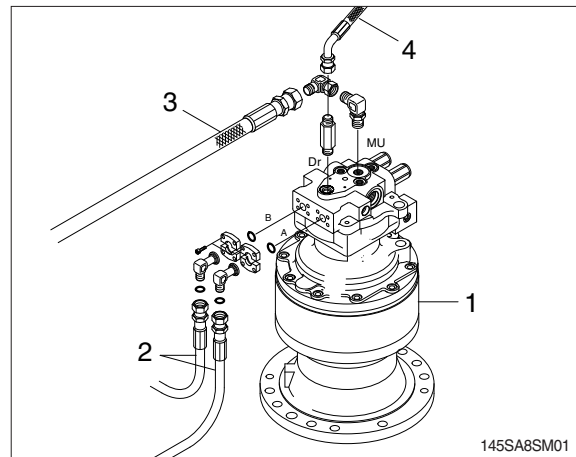

2. DISASSEMBLY AND ASSEMBLY OF SWING MOTOR

1) STRUCTURE

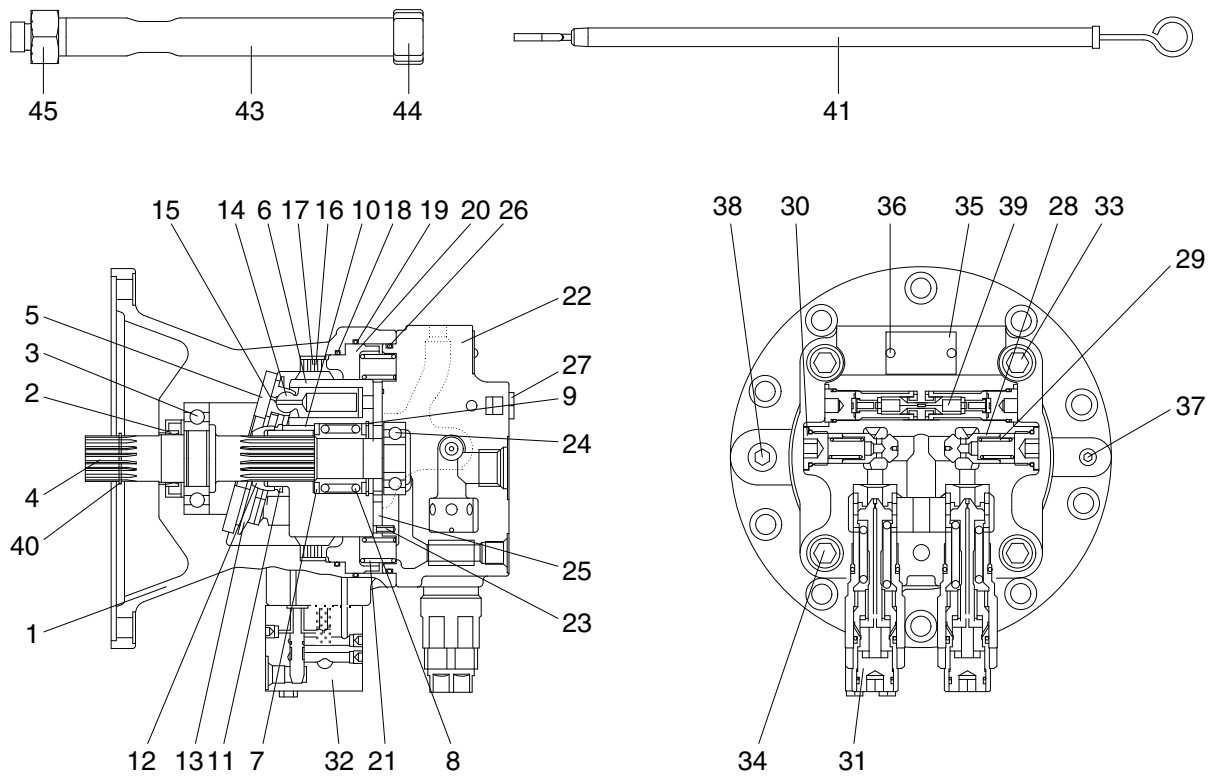

1	Casing	16	Separate plate	31	Relief valve assy
2	Oil seal	17	Friction plate	32	Brake valve assy
3	Ball bearing	18	O-ring	33	Socket bolt
4	Drive shaft	19	O-ring	34	Socket bolt
5	Shoe plate	20	Brake piston	35	Name plate
6	Cylinder block	21	Spring	36	Screw
7	Washer	22	Valve casing	37	Plug
8	Spring	23	Spring pin	38	Plug
9	Snap ring	24	Ball bearing	39	Reactionless valve assy
10	Roller	25	Valve plate	40	Snap ring
11	Collar washer	26	O-ring	41	Level gauge
12	Thrust ball	27	Plug	42	pipe
13	Retainer plate	28	Plunger	43	Bar
14	Piston	29	Spring	44	Cap
15	Shoe	30	Plug	45	Reducer

145WF2SM81

3. REMOVAL AND INSTALL OF REDUCTION GEAR

1) REMOVAL

- (1) Remove the swing motor assembly.
For details, see removal of swing motor assembly.
- (2) Sling reduction gear assembly (1) and remove dowel pin (3) and mounting bolts (2).
- (3) Remove the reduction gear assembly.
 - Reduction gear weight : 75 kg
(165 lb)



2) INSTALL

- (1) Carry out installation in the reverse order to removal.
 - Tightening torque : 29.6 ± 3.2 kgf · m
(214 ± 23.1 lbf · ft)

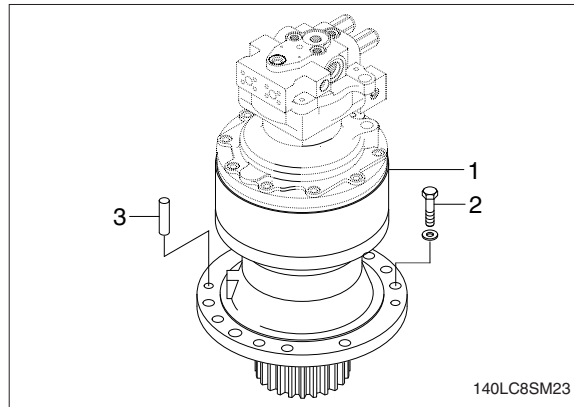

4. DISASSEMBLY AND ASSEMBLY OF REDUCTION GEAR

1) STRUCTURE

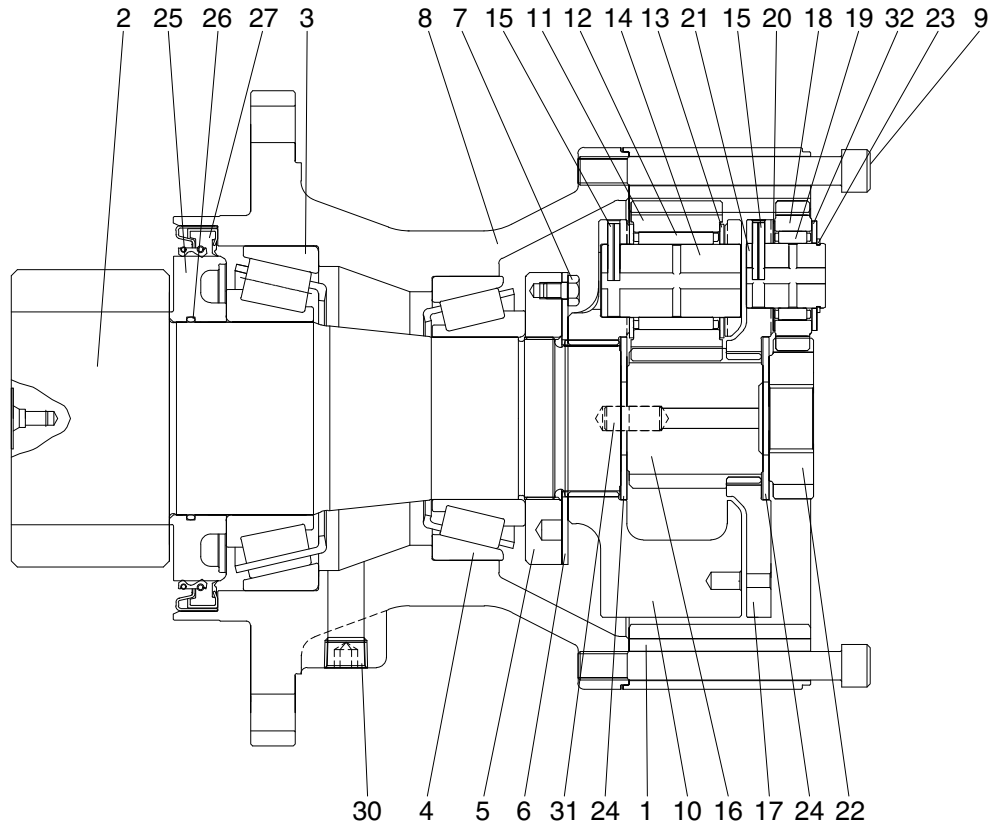

125LCR2SM23

1	Ring gear	11	Planetary gear No. 2	21	Carrier pin No. 1
2	Drive shaft	12	Needle bearing No. 2	22	Sun gear No. 1
3	Taper roller bearing	13	Thrust washer No. 2	23	Snap ring
4	Taper roller bearing	14	Carrier pin No. 2	24	Thrust plate
5	Ring nut	15	Spring pin	25	Sleeve
6	Lock plate	16	Sun gear No. 2	26	O-ring
7	Hexagon bolt	17	Carrier No. 1	27	Oil seal
8	Casing	18	Planetary gear No. 1	30	Plug
9	Socket bolt	19	Needle bearing No. 1	31	Parallel pin
10	Carrier No. 2	20	Thrust washer No. 1	32	Thrust washer No. 1

2) DISASSEMBLY

- (1) Remove the swing motor, and then place swing reduction gear on the bench.

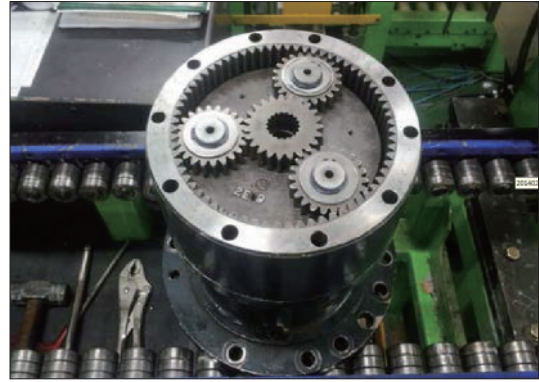

125LCR8SM60

- (2) Disassemble sun gear No.1 (22).

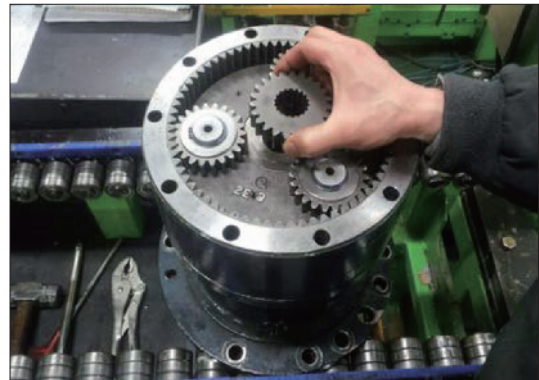

125LCR8SM61

- (3) Disassemble carrier No.1 sub assembly.

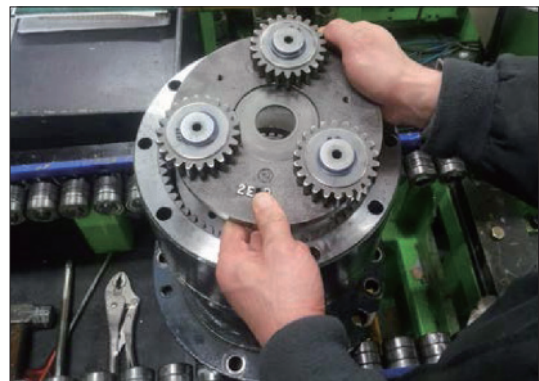

125LCR8SM62

Carrier No.1 sub assy disassembly

- (4) Put carrier No.1 sub assembly on the bench, then remove the snap ring (23).



125LCR8SM63

- (5) Disassemble thrust washer No.1 (upper)
(32).(3 pcs)



125LCR8SM64

- (6) Disassemble planetary gear No.1 (18).
(3 pcs)



125LCR8SM65

- (7) Disassemble thrust plate (24).



125LCR8SM66

- (8) Disassemble needle bearing No.1 (19).
(3 pcs)

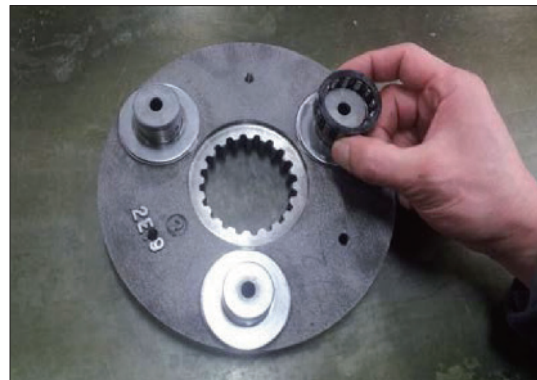

125LCR8SM67

(9) Disassemble thrust washer No.1 (lower) (20).
(3 pcs)

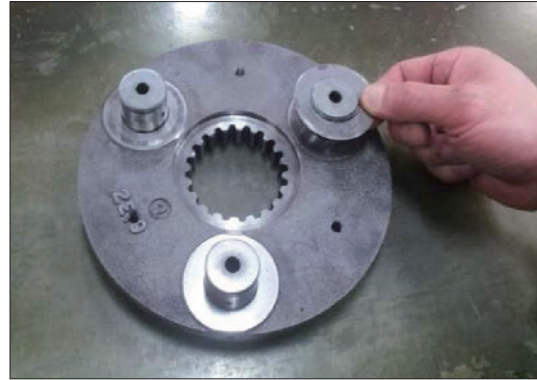

125LCR8SM68

(10) After placing spring pin (15) to center of carrier pin No.1 (21) with a jig, disassemble it.
(3 pcs)
※ Do not reuse spring pin, carrier and carrier pin.

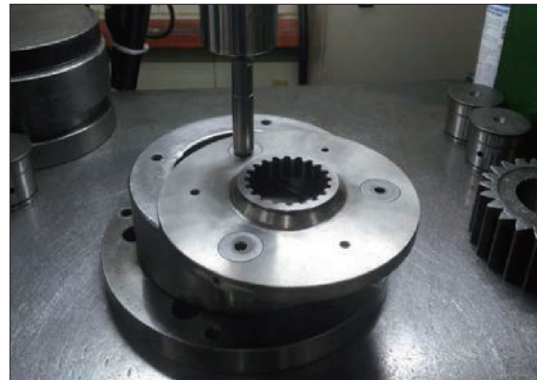

125LCR8SM69

(11) Disassemble sun gear No.2 (16).

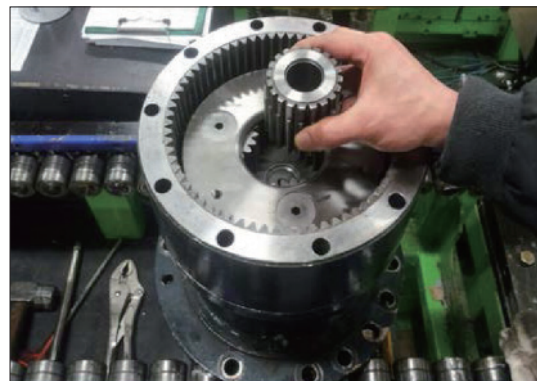

125LCR8SM70

(12) Disassemble carrier No.2 sub assembly.

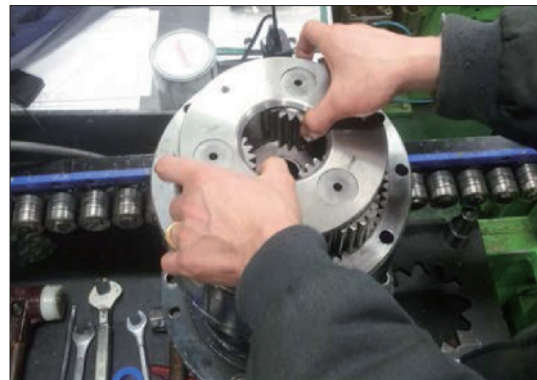

125LCR8SM71

Carrier No.2 sub assy disassembly

(13) After placing spring pin (15) to center of carrier pin No.2 (14) with a press machine, disassemble it.(3 pcs)

※ Do not reuse spring pin.



125LCR8SM72

(14) Disassemble planetary gear No.2.(3 pcs)



125LCR8SM73

(15) Disassemble thrust plate (24).



125LCR8SM74

(16) Disassemble thrust washer No.2 (13).(6 pcs)



125LCR8SM75

(17) Disassemble needle bearing No.2 (12).
(3 pcs)



125LCR8SM76

(18) Separate ring gear (1) from casing (8).



125LCR8SM77

(19) Loosen bolt (7) (4 pcs), and disassemble lock plate (6).

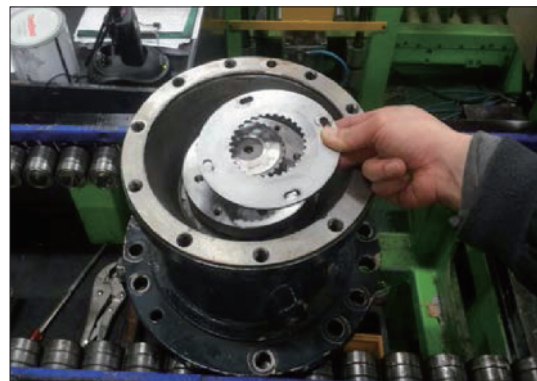

125LCR8SM78

(20) Disassemble ring nut (5) by using the jig.



125LCR8SM79

Drive shaft sub assy disassembly

(21) Separate drive shaft sub assembly from casing (8).



125LCR8SM80

(22) Disassemble taper roller bearing (3) and oil seal (27) by using a press machine.



125LCR8SM81

(23) Disassemble sleeve (25) and O-ring (26).



125LCR8SM82

(24) Disassemble the outer ring of taper roller bearing (3) in casing (8) by using the jig.



125LCR8SM83

3) ASSEMBLY

※ Even though assembly is accomplished by reversing disassembly steps, be careful of the following.

- ① Repair the damaged part when disassembling and prepare parts for exchange in advance.
- ② All parts should be cleaned with cleaner, dried with compressed air.
- ③ Sliding surface, O-ring, bearing and oil seal should be lubricated with clean hydraulic oil, prior to final assembly.
- ④ Replacement of O-ring and oil seal with new parts is generally recommended.
- ⑤ Use a torque wrench to make sure that assembly fasteners are tightened to specified values.
- ⑥ When assembling bolt, spread loctite.

Carrier No.1 sub assembly

- (1) After heating the carrier No.1 (17), assemble carrier pin No.1 (21) to the side without the hole.



125LCR8SM84

- (2) After drilling $\varnothing 6$ hole, assemble spring pin (15).(3 pcs)

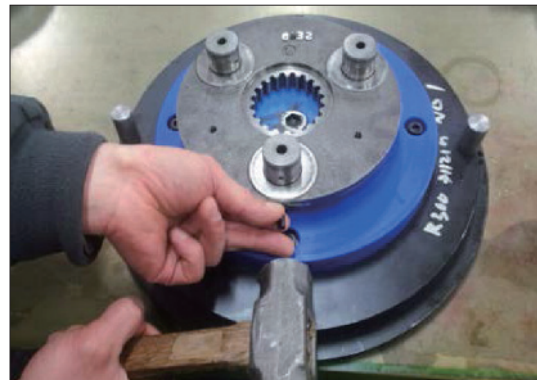

125LCR8SM85

(3) Caulking is performed on the assembled spring pin unit.

※ To cover pins, implement the caulking in two places that are located direction of 180 degrees around assembled spring pin.

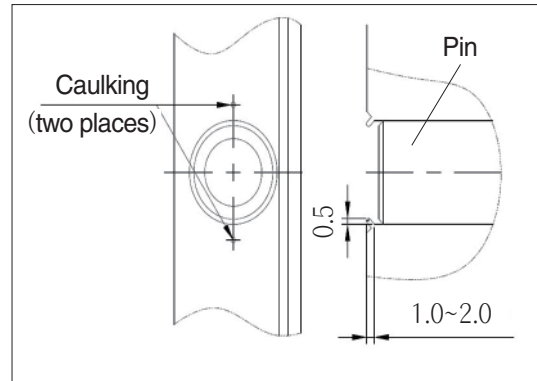

125LCR8SM86

(4) Assemble thrust washer No.1 (lower) (20).
(3 pcs)

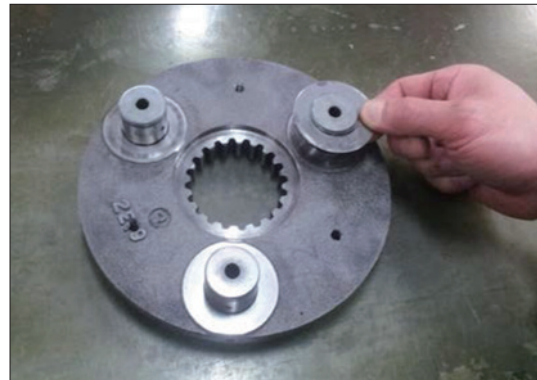

125LCR8SM87

(5) Assemble needle bearing No.1 (19).(3 pcs)

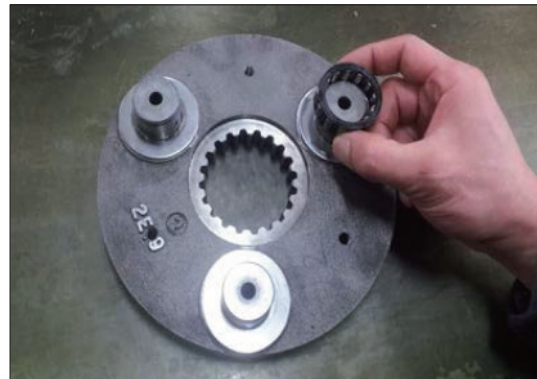

125LCR8SM88

(6) Assemble thrust plate (24).



125LCR8SM89

- (7) Assemble planetary gear No.1 (18) of which groove is faced downward.(3 pcs)



125LCR8SM90

- (8) Assemble thrust washer No.1 (upper) (32).
(3 pcs)



125LCR8SM91

- (9) Assemble snap ring (23) (3 pcs), complete carrier No.1 sub assembly.
※ Gear rotation state should be smooth.



125LCR8SM92

Carrier No.2 sub assy assembly

- (10) Assemble needle bearing No.2 (12) in the planetary gear No.2 (11).



125LCR8SM93

- (11) After spreading grease on thrust washer No.2 (13), assemble it on both upper side and lower side of planetary gear No.2.



125LCR8SM94

- (12) Assemble thrust plate (24).



125LCR8SM95

- (13) Assemble planetary gear No.2 in the carrier No.2 (10).(3 pcs)
※ Thrust washer No.2 should not separated.



125LCR8SM96

- (14) Assemble carrier pin No.2 (14) to match the pin hole of the carrier No.2.(3 pcs)



125LCR8SM97

(15) Assemble spring pin (15).(3 pcs)



125LCR8SM98

(16) Caulking is performed on the assembled spring pin unit.

- ※ To cover pins, implement the caulking in two places that are located direction of 180 degrees around assembled spring pin.

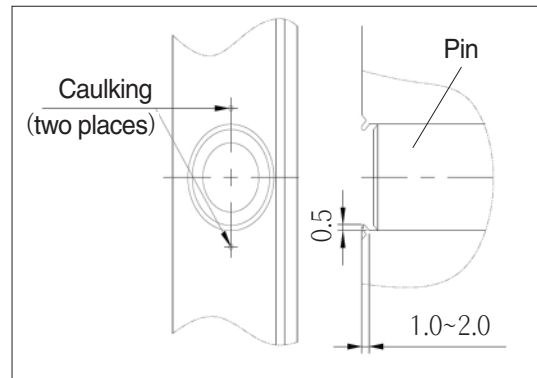

125LCR8SM99

Drive shaft sub assy assembly

(17) After heating sleeve (25), assemble O-ring (26) to groove of inside diameter in it.



125LCR8SM100

(18) Shrink fit the sleeve on drive shaft (2).

- ※ Be careful of fully seat at the bottom.



125LCR8SM101

- (19) Shrink fit taper roller bearing (3) on drive shaft, complete drive shaft sub assembly.



125LCR8SM102

Casing assembly

- (20) Press outer ring of the taper roller bearing in the casing (8) by using the jig.

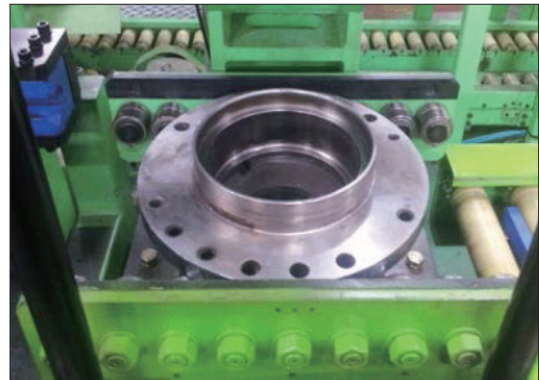

125LCR8SM103

- (21) Press in oil seal (27) by using the jig.
※ Be careful of the direction of the assembly.

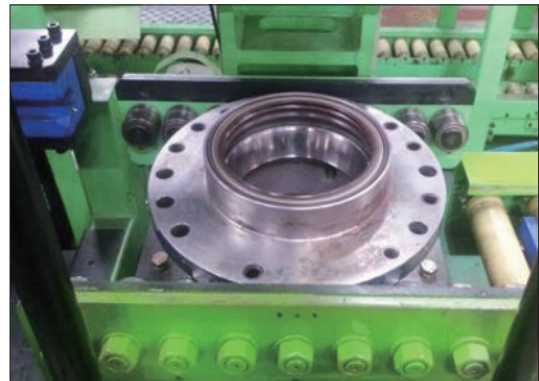

125LCR8SM104

- (22) Assemble drive shaft sub assembly.
※ Be careful of damage of oil seal.



125LCR8SM105

(23) After fixing drive shaft so that it does not fall, and then turn it over, press taper bearing (4).



125LCR8SM106

(24) Assemble nut ring (5) by using the jig.

※ Tightening torque : 3.5 ± 0.4 kgf · m
(25.3 ± 2.9 lbf · ft)



125LCR8SM107

(25) Place lock plate (6) on the nut ring.

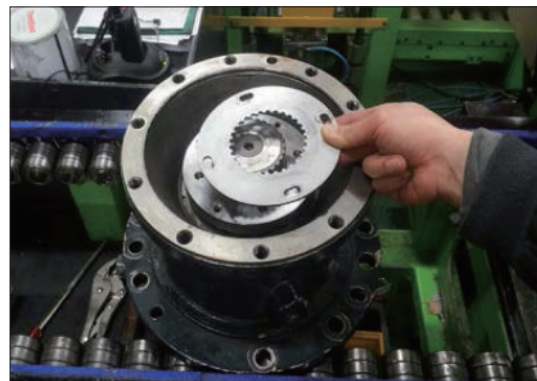

125LCR8SM108

(26) After spreading loctite #242, assemble the bolt (7) (4 pcs).

※ Tightening torque : 2.5 ± 0.25 kgf · m
(18.1 ± 1.8 lbf · ft)

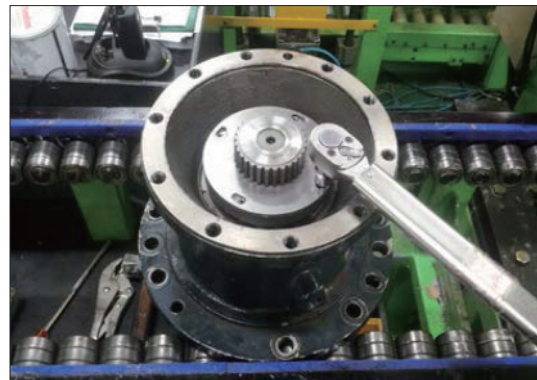

125LCR8SM109

(27) Press parallel pin (31) by using press machine.

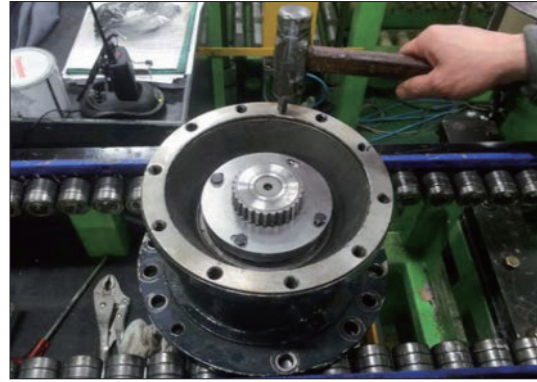

125LCR8SM110

(28) Spread the loctite #515 on the casing with reference to the right detail view.
※ Loctite should not flow into casing.

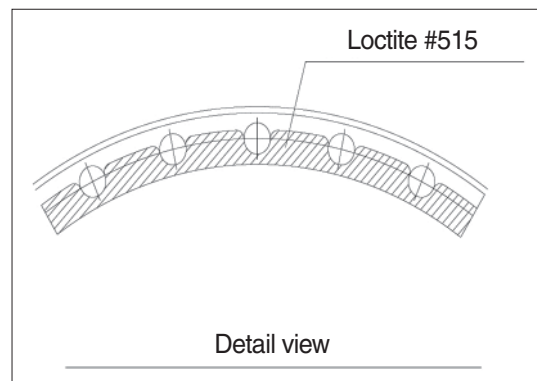

125LCR8SM111

(29) Assemble ring gear (1) in accordance with a pin hole on casing.
※ Be careful of damage of the ring gear.

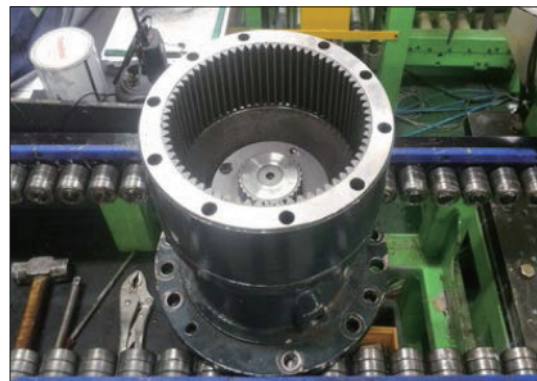

125LCR8SM112

(30) Assemble carrier No.2 sub assembly.

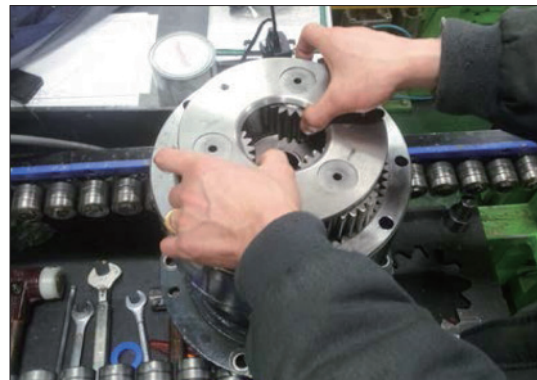

125LCR8SM113

(31) Assemble sun gear No.2 (16).

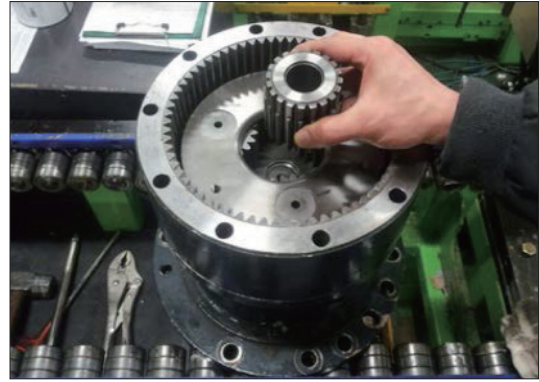

125LCR8SM114

(32) Assemble carrier No.1 sub assembly.

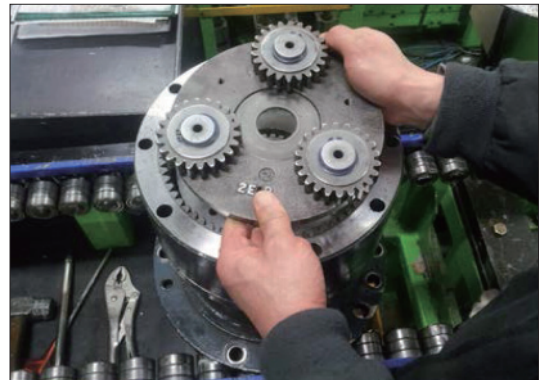

125LCR8SM115

(33) Assemble sun gear No.1 (22) of which grinding surface is faced downward.

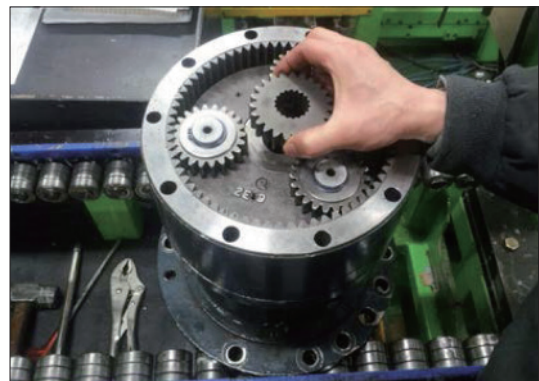

125LCR8SM116

(34) Fill with gear oil 3.5 liter.



125LCR8SM117

GROUP 6 TRAVEL DEVICE (STD)

1. REMOVAL AND INSTALL

1) REMOVAL

- (1) Swing the work equipment 90° and lower it completely to the ground.
- (2) Operate the control levers and pedals several times to release the remaining pressure in the hydraulic piping.
- (3) Loosen the breather slowly to release the pressure inside the hydraulic tank.

▲ Escaping fluid under pressure can penetrate the skin causing serious injury.

※ When pipes and hoses are disconnected, the oil inside the piping will flow out, so catch it in oil pan.

- (4) Remove the track shoe assembly.
For details, see **removal of track shoe assembly**.

- (5) Remove the cover.

- (6) Remove the hose.

※ Fit blind plugs to the disconnected hoses.

- (7) Remove the bolts and the sprocket.
 - Tightening torque : $29.7 \pm 3.0 \text{ kgf} \cdot \text{m}$
($215 \pm 21.7 \text{ lbf} \cdot \text{ft}$)

- (8) Sling travel device assembly (1).

- (9) Remove the mounting bolts (2), then remove the travel device assembly.
 - Weight : 140 kg (310 lb)
 - Tightening torque : $25.7 \pm 4.0 \text{ kgf} \cdot \text{m}$
($186 \pm 28.9 \text{ lbf} \cdot \text{ft}$)

2) INSTALL

- (1) Carry out installation in the reverse order to removal.
- (2) Bleed the air from the travel motor.
 - ① Remove the air vent plug.
 - ② Pour in hydraulic oil until it overflows from the port.
 - ③ Tighten plug lightly.
 - ④ Start the engine, run at low idling, and check oil come out from plug.
 - ⑤ Tighten plug fully.
- (3) Confirm the hydraulic oil level and check the hydraulic oil leak or not.

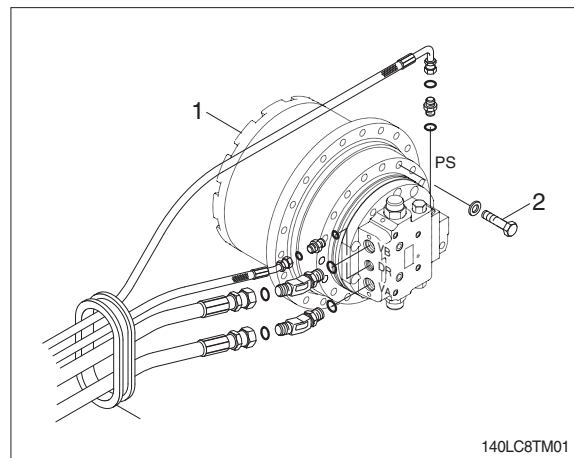

2. TRAVEL MOTOR

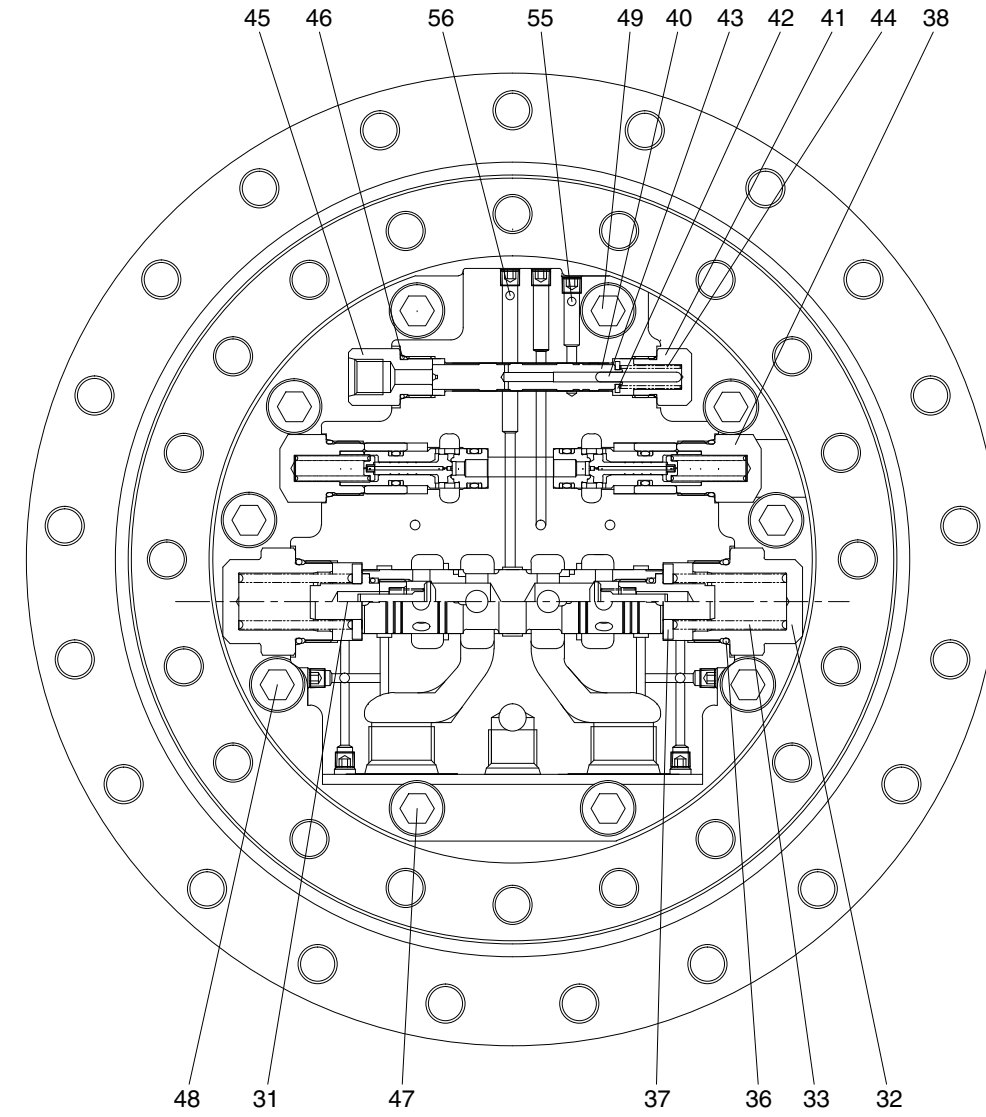
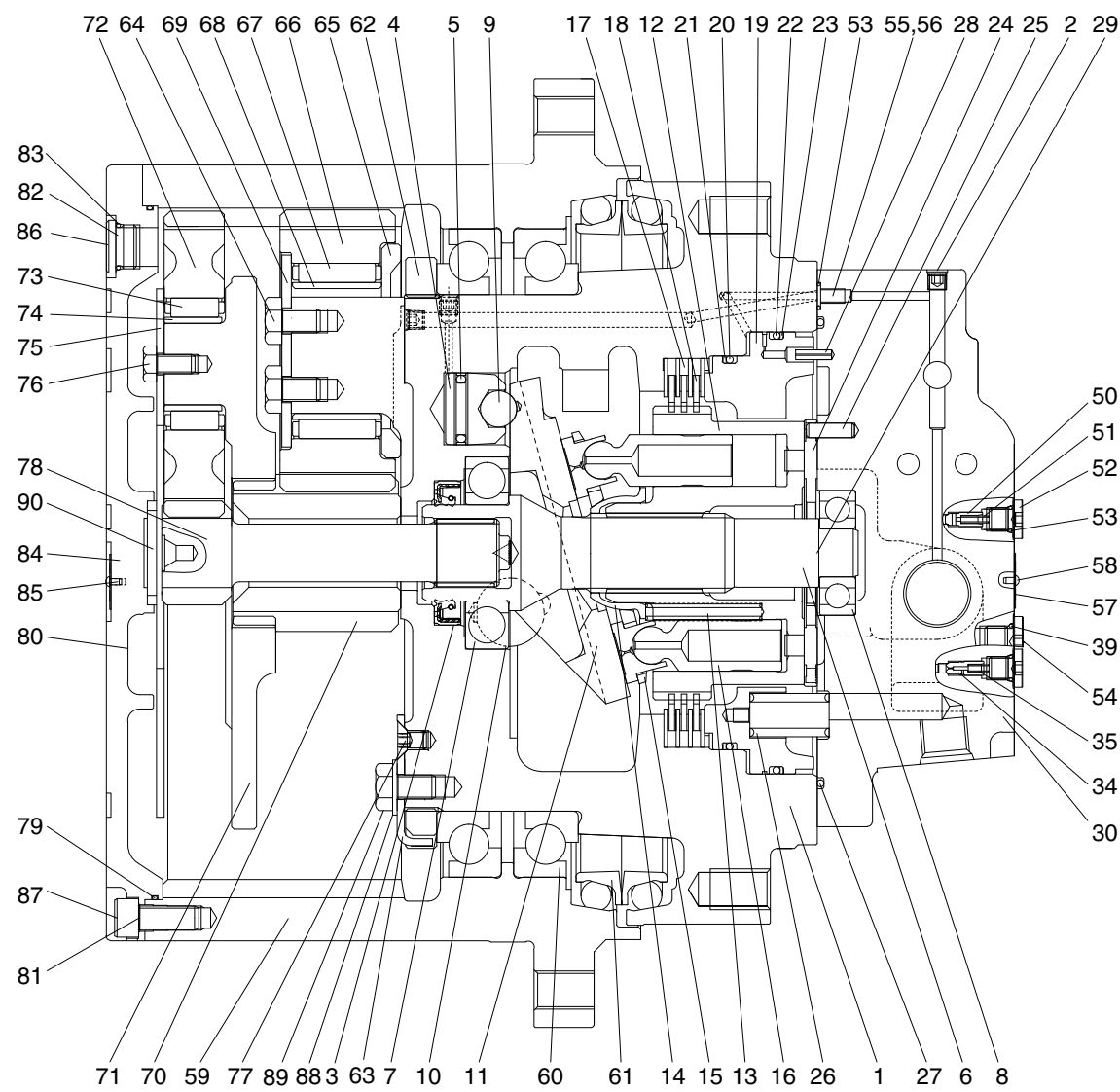

- | | | | | |
|----------------------|--------------------|-----------------------------|------------------------|---------------------------|
| 1 Casing | 19 Parking piston | 37 Spring seat | 55 Restrictor | 73 Needle bearing No.1 |
| 2 Plug | 20 O-ring | 38 Relief valve assy | 56 Restrictor | 74 Inner race No. 1 |
| 3 Oil seal | 21 Back up ring | 39 O-ring | 57 Name plate | 75 Thrust plate No. 1 |
| 4 Piston | 22 O-ring | 40 Spool | 58 Rivet | 76 Hexagon head bolt |
| 5 Piston seal | 23 Back up ring | 41 Plug | 59 Ring gear | 77 Countersunk head screw |
| 6 Shaft | 24 Valve plate | 42 Spring seat | 60 Bearing | 78 Sun gear No.1 |
| 7 Front ball bearing | 25 Spring pin | 43 Parallel pin | 61 Floating seal assy | 79 O-ring |
| 8 Rear ball bearing | 26 Spring | 44 Spring | 62 Nut ring | 80 Cover |
| 9 Steel ball | 27 O-ring | 45 Connector | 63 Lock plate | 81 Hex socket head bolt |
| 10 Pivot | 28 Spring pin | 46 O-ring | 64 Hexagon head bolt | 82 Plug |
| 11 Swash plate | 29 Parallel pin | 47 Hexagon socket head bolt | 65 Thrust plate No. 2 | 83 O-ring |
| 12 Cylinder block | 30 Rear cover | 48 Hexagon socket head bolt | 66 Planetary gear No.2 | 84 Name plate |
| 13 Spring | 31 Main spool assy | 49 Hexagon socket head bolt | 67 Needle bearing No.2 | 85 Rivet |
| 14 Ball guide | 32 Cover | 50 Check valve | 68 Inner race No. 2 | 86 Rubber cap |
| 15 Retainer plate | 33 Spring | 51 Spring | 69 Thrust washer No. 2 | 87 Rubber cap |
| 16 Piston assy | 34 Restrictor | 52 Plug | 70 Sun gear No.2 | 88 Plain washer |
| 17 Friction plate | 35 Spring | 53 O-ring | 71 Carrier No.1 | 89 Hexagon bolt |
| 18 Separated plate | 36 O-ring | 54 Plug | 72 Planetary gear No.1 | 90 Thrust plate |

130ZF2TM21

2) DISASSEMBLY

- (1) Choose a clean place, remove contaminants (dust, etc) and cleans motor before placing it on worktable.
 - ※ Lay the rubber plate on worktable and take care not to damage the component.



125LCR8TM02

- (2) Remove the connector (45) using 21 mm socket wrench.

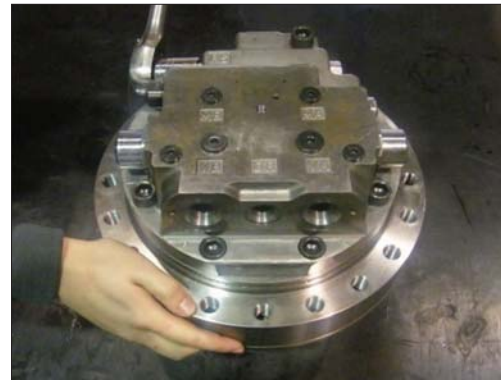

125LCR8TM03

- (3) Remove plug (41) using 21 mm socket wrench.

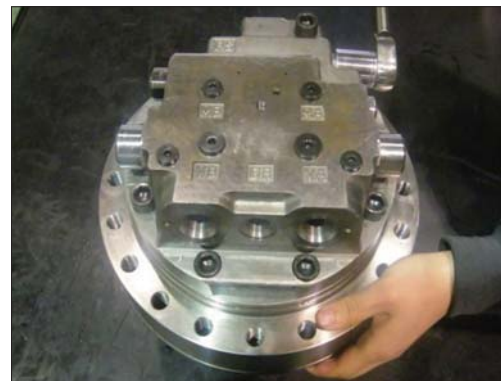

125LCR8TM04

- (4) Disassemble parallel pin (43) and spring (44).
 - ※ Do not lose spring.
 - ※ Do not mix spring with other springs.

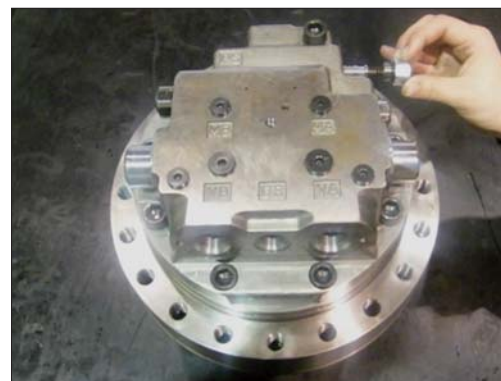

125LCR8TM05

(5) Remove spring seat (42) and spool (40).



125LCR8TM06

(6) Disassemble relief valve assembly (38) using 26 mm socket wrench. (2 sets)

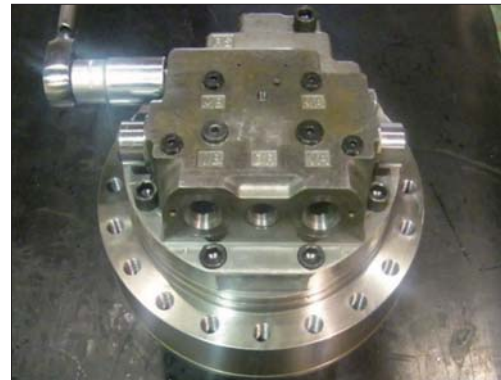

125LCR8TM07

(7) Disassemble cover (32) using 41 mm socket wrench.

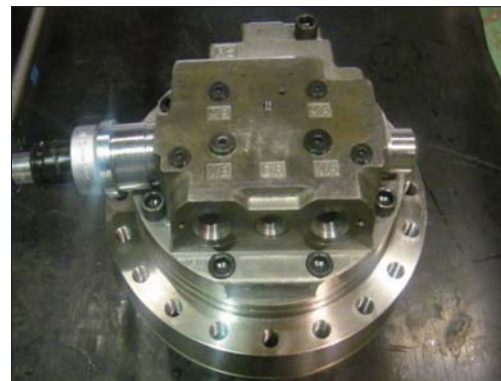

125LCR8TM08

(8) Disassemble spring seat (37) and spring (33). (2 sets)



125LCR8TM09

- (9) Separate main spool assembly (31) from rear cover.

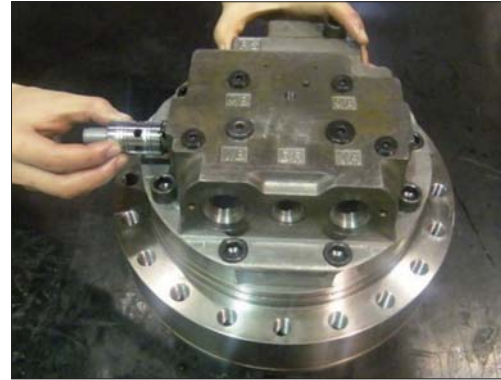

125LCR8TM10

- (10) Unscrew socket bolt (47) (1EA), (48) (3EA), (49) (6EA) from rear cover.



125LCR8TM11

- (11) Remove parallel pin (29).



125LCR8TM12

- (12) From rear cover, disassemble valve plate (24) and O-ring (27).

※ Take care not to damage assembly surface of rear cover.



125LCR8TM13

(13) Disassemble restrictor (55, 56) (2EA).

- ※ Mark the number on restrictor and its hole to avoid confusing (55) and (56).



125LCR8TM14

(14) Remove plug (52).



125LCR8TM15

(15) Remove restrictor (34) and spring (35). (2 sets)

- ※ Do not confuse restrictor (34) and check valve (50).
- ※ Do not confuse spring (35) and spring (51).
- ※ Do not lose spring.
- ※ Do not mix spring with other springs.

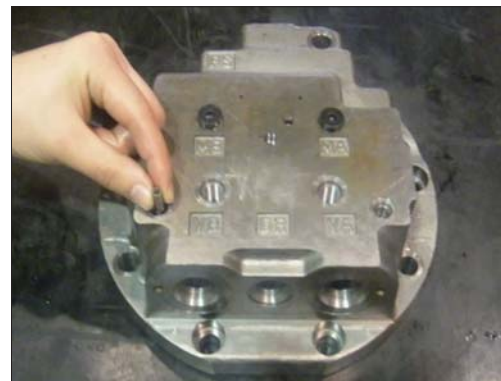

125LCR8TM16

(16) Remove plug (52) using 5 mm hexagon wrench.

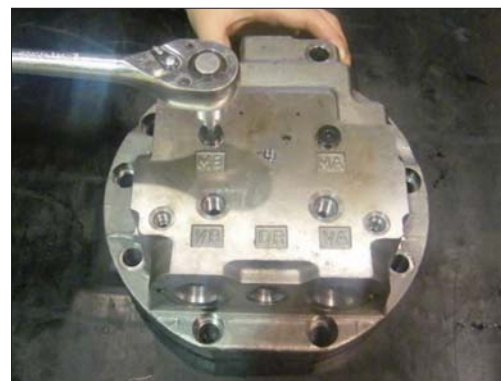

125LCR8TM17

(17) Remove check valve (50) and spring (51). (2 sets)

- ※ Do not confuse restrictor (34) and check valve (50).
- ※ Do not confuse spring (35) and spring (51).
- ※ Do not lose spring.
- ※ Do not mix spring with other springs.



125LCR8TM18

(18) From parking piston, remove spring (26) (12ea).

- ※ Do not lose spring.
- ※ Do not mix spring with other springs.



125LCR8TM19

(19) Disassemble parking piston (19) using air gun or jig.



125LCR8TM20

(20) From parking piston, separate O-ring (22) and back-up ring (23).



125LCR8TM21

(21) From parking piston separate O-ring (20) and back-up ring (21).



125LCR8TM22

(22) Lay casing down horizontally and remove cylinder block assembly, friction plate (17) (3EA) and separator plate (18) (4EA).



125LCR8TM23

(23) Separate retainer plate (15) and piston assembly (16).

- ※ Take care not to damage sliding surface of each component.



125LCR8TM24

(24) Disassemble ball guide (14) and spring (13) (9EA).

- ※ Do not lose spring.
- ※ Do not mix spring with other springs.



125LCR8TM25

(25) Disassemble swash plate (11) and pivot (10).

※ Take care not to damage sliding surface.



125LCR8TM26

(26) Disassemble shaft (6) and ball bearing (7).

※ Do not remove ball bearing unless malfunction is detected, since it is mounted by shrink fit.



125LCR8TM27

(27) Disassemble 1, 2 speed piston (4) and steel ball (9) using air gun.



125LCR8TM28

(28) Disassemble piston seal (5).



125LCR8TM29

(29) Turn casing (1) upside down and remove oil seal (3) using jig.



125LCR8TM30

3) ASSEMBLY

※ Even though assembly is accomplished by reversing disassembly steps, be careful of the following.

- ① Repair the damaged part when disassembling and prepare parts for exchange in advance.
- ② All parts should be cleaned with cleaner, dried with compressed air.
- ③ Sliding surface, O-ring, bearing and oil seal should be lubricated with clean hydraulic oil, prior to final assembly.
- ④ Replacement of O-ring and oil seal with new parts is generally recommended.
- ⑤ Use a torque wrench to make sure that assembly fasteners are tightened to specified values shown table1.
- ⑥ When assembling bolt, spread Loctite.

(1) Put casing (1) on the worktable.



125LCR8TM31

(2) After applying grease on the external diameter of oil seal (3), insert oil seal in casing.



125LCR8TM32

- (3) After applying grease on pivot (10), insert steel ball in casing.



125LCR8TM33

- (4) After assembling piston seal (5) and steel ball (9) in 1, 2 speed piston (4), insert piston in hole of casing.
※ Check whether piston sticks in hole.
※ Use piston seal jig.



125LCR8TM34

- (5) Mount ball bearing (7) on shaft (6) by shrink fit.
Insert shaft in casing.
※ Take care not to damage oil seal.



125LCR8TM35

- (6) Assemble swash plate (11) by matching its hole and steel ball.
※ Take care not to damage sliding surface.



125LCR8TM36

- (7) Assemble spring (13) (9ea) and ball guide (14) in cylinder block (12) in that order.



125LCR8TM37

- (8) Insert piston assembly (16) in retainer plate (15) and assemble them in cylinder block.
※ Spread hydraulic oil on piston assembly.
※ Take care not to damage each component.
※ Check cylinder block and piston assembly runs properly.



125LCR8TM38

- (9) Lay casing down horizontally and assemble cylinder block assembly by matching its spline with shaft.
※ Make sure swash plate stays in place.
※ Check the assembling status of cylinder block by pressing it.



125LCR8TM39

- (10) Assemble separator plate (18) (4EA) and friction plate (17) (3EA) alternately.

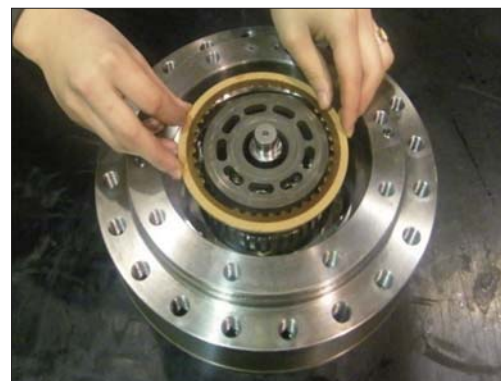

125LCR8TM40

(11) Insert back-up ring & O-ring in parking piston.



125LCR8TM41

(12) Align the pin hole of parking piston (19) with oil hole of casing, assemble them using jig.
※ Spread grease on O-ring and back-up ring.
※ Take care not to damage components.



125LCR8TM42

(13) Insert spring (26) (12EA) in parking piston.



125LCR8TM43

(14) Insert parallel pin (29) (2EA) in casing.



125LCR8TM44

(15) Assemble check valve (50) and spring (51) in order.

※ Do not confuse check valve (50) and restrictor (34).

※ Do not confuse spring (51) and spring (35)



125LCR8TM45

(16) Clamp plug (52) using 5 mm hexagon wrench.

※ Tightening torque : $3.0 \pm 0.3 \text{ kgf} \cdot \text{m}$
($21.7 \pm 2.2 \text{ lbf} \cdot \text{ft}$)

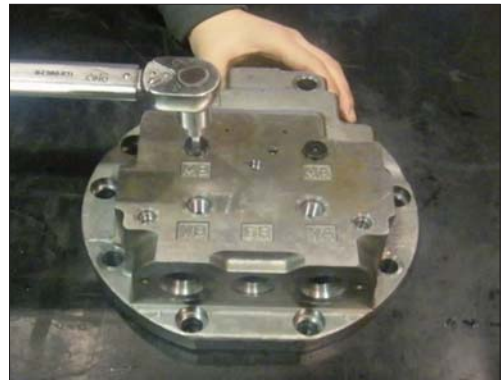

125LCR8TM46

(17) Assemble restrictor (34) and spring (35) in order.

※ Do not confuse check valve (50) and restrictor (34).

※ Do not confuse spring (51) and spring (35).

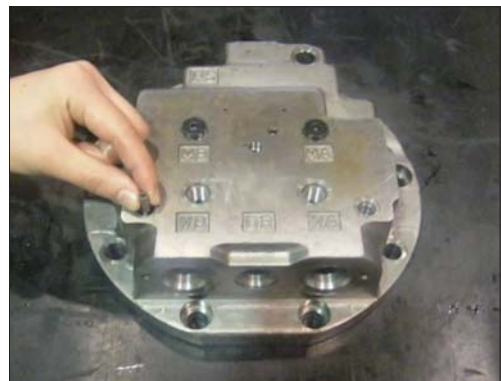

125LCR8TM47

(18) Clamp plug (52).

※ Tightening torque : $3.0 \pm 0.3 \text{ kgf} \cdot \text{m}$
($21.7 \pm 2.2 \text{ lbf} \cdot \text{ft}$)

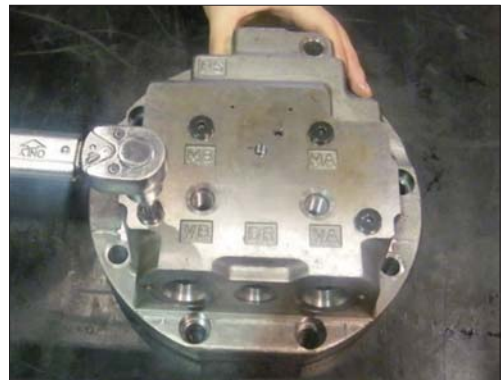

125LCR8TM48

(19) Clamp plug (54).

- ※ Tightening torque : 4.5 ± 0.5 kgf · m
(32.5 ± 3.6 lbf · ft)



125LCR8TM49

(20) Assemble restrictor (55) and (56) in rear cover.

- ※ Check whether the restrictor is placed in exact hole.
- ※ Do not confuse (55) and (56).

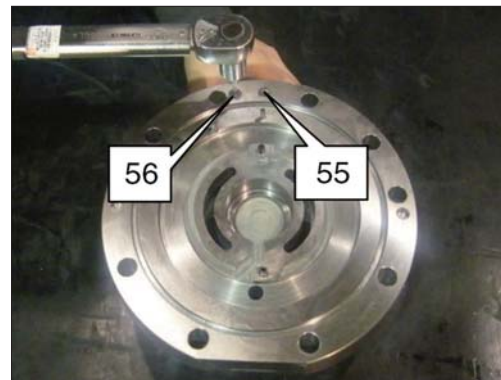

125LCR8TM50

(21) Assemble ball bearing (8) in rear cover using jig.



125LCR8TM51

(22) Insert spring pin (25) (2ea) and (28) in rear cover using jig.



125LCR8TM52

(23) After spreading grease sufficiently to the bottom side of valve plate (24), assemble valve plate in rear cover by matching its holes with pins.

- ※ Take care not to damage sliding surface.
- ※ Pay attention to the assembly direction.

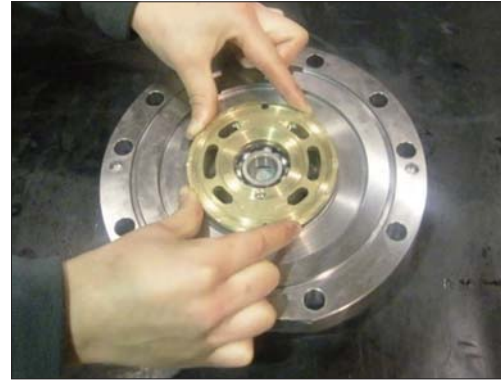

125LCR8TM53

(24) Assemble O-ring (27) in rear cover.

- ※ Spread grease on O-ring.



125LCR8TM54

(25) Put rear cover upon casing, paying attention to the location of pin and hole. And tighten bolt (47), (48) and (49).

- ※ Tightening torque : 17.5 ± 1.8 kgf · m
(127 ± 13.0 lbf · ft)
- ※ Make sure valve plate stays in place.
- ※ Check bolt position.



125LCR8TM55

(26) Assemble main spool assembly (31), spring seat (37) and spring (33) in rear cover.

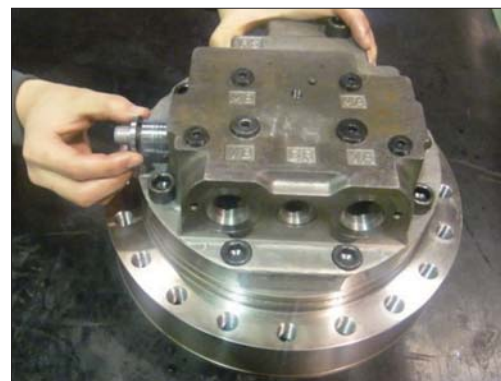

125LCR8TM56

(27) Settle cover (32).

- ※ Tightening torque : 15 ± 1.5 kgf · m
(108 ± 10.8 lbf · ft)

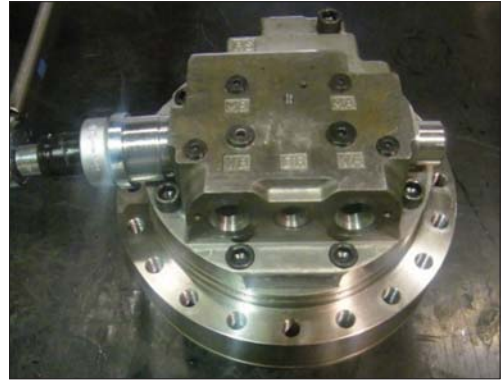

125LCR8TM57

(28) Insert relief valve (38) in rear cover.

- ※ Tightening torque : 15 ± 1.8 kgf · m
(108 ± 13.0 lbf · ft)

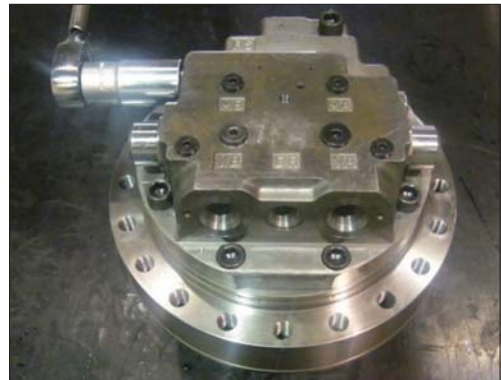

125LCR8TM58

(29) After clamping connector (45) to rear cover, assemble spool (40).

- ※ Tightening torque : 5.5 ± 0.5 kgf · m
(39.8 ± 3.6 lbf · ft)

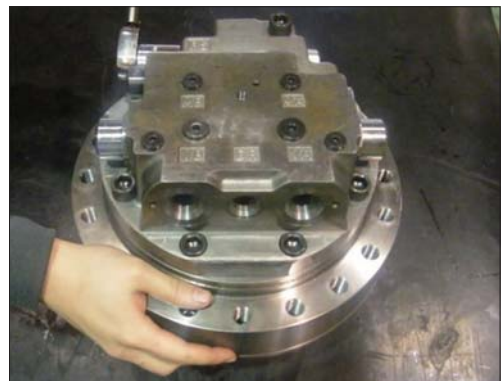

125LCR8TM59

(30) After inserting parallel pin (43), assemble seat-spring (42).

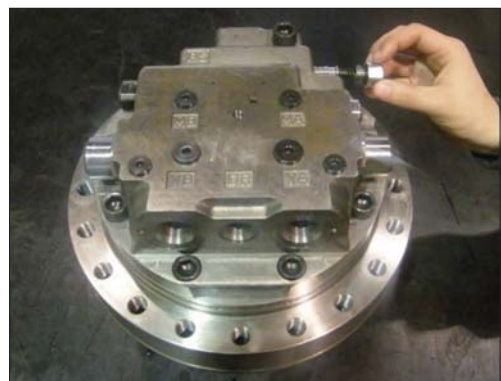

125LCR8TM60

(31) After assembling spring (44) in order, clamp plug (41).

※ Tightening torque : $5.5 \pm 0.5 \text{ kgf} \cdot \text{m}$
($39.8 \pm 3.6 \text{ lbf} \cdot \text{ft}$)

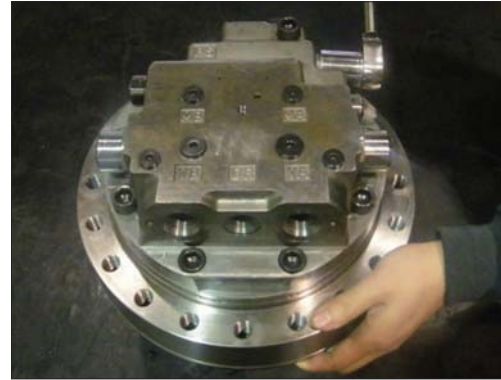

125LCR8TM61

3. TRAVEL REDUCTION GEAR DISASSEMBLY

1) While travel reduction gear is tilted to one side disassemble PF3/8 plug (82), remove gear oil and place motor side to the bench.



125LCR8TM70

2) Disassemble cover (80) by unscrewing the M10 bolts (81) (12 pcs).



125LCR8TM71

3) Disassemble sun gear No.1 (78).



125LCR8TM72

4) Disassemble carrier No.1 assembly.



125LCR8TM73

Carrier No. 1 sub assy disassembly

- 5) Disassemble M8 bolt (76) from the carrier assembly. (3 pcs)



125LCR8TM74

- 6) Disassemble thrust plate No.1 (75) from the carrier assembly.



125LCR8TM75

- 7) Disassemble planetary gear No.1 (72).(3 pcs)



125LCR8TM76

- 8) Disassemble needle bearing (73).(3 pcs)
※ Do not disassemble inner race in the absence of abnormalities.



125LCR8TM77

9) Disassemble Sun gear No.2 (70).



125LCR8TM78

10) Disassemble M10 bolt (64).(4 pcs)



125LCR8TM79

11) Disassemble thrust washer No.2 (65).(4 pcs)



125LCR8TM80

12) Disassemble planetary gear No.2 (66).(4 pcs)



125LCR8TM81

13) Disassemble needle bearing No.2 (67).(4 pcs)



125LCR8TM82

14) Disassemble thrust plate No.2 (69).(4 pcs)

※ Do not disassemble inner race in the absence of abnormalities.



125LCR8TM83

15) Disassemble M10 bolt (89), plain washer (88) and M8 screw (77).



125LCR8TM84

16) Disassemble lock plate (63).



125LCR8TM85

17) Disassemble nut ring (62) by using the jig.



125LCR8TM86

18) Disassemble ring gear assembly (59) from motor assembly.



125LCR8TM87

19) Disassemble floating seal assembly (61) from ring gear assembly and motor assembly.



125LCR8TM88

20) Disassemble bearing (60) (2ea) from ring gear assembly.

※ Do not disassemble bearing in the absence of abnormalities.

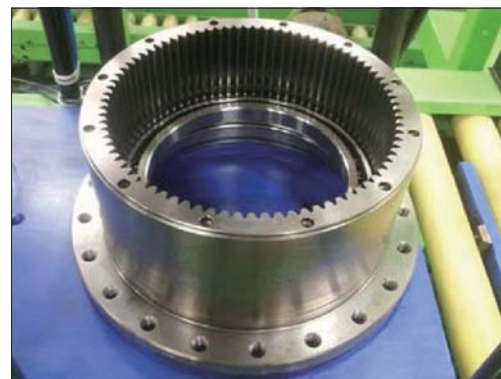

125LCR8TM89

4. TRAVEL REDUCTION GEAR ASSEMBLY

※ Even though assembly is accomplished by reversing disassembly steps, be careful of the following.

- ① Repair the damaged part when disassembling and prepare parts for exchange in advance.
- ② All parts should be cleaned with cleaner, dried with compressed air.
- ③ Sliding surface, O-ring, bearing and oil seal should be lubricated with clean hydraulic oil, prior to final assembly.
- ④ Replacement of O-ring and oil seal with new parts is generally recommended.
- ⑤ Use a torque wrench to make sure that assembly fasteners are tightened to specified values.
- ⑥ When assembling bolt, spread loctite.

1) Put carrier No.1 (71) on the jig, and shrink-fit inner race No.1 (74) to carrier pin.(3 places)

※ Do not tilt inner race to one side.

※ Match inner race and end of carrier pin.



125LCR8TM90

2) Assemble needle bearing No.1 (73).(3 pcs)



125LCR8TM91

- 3) Assemble planetary gear No.1 (72) of which groove is faced downward. (3 places)



125LCR8TM92

- 4) Assemble thrust plate No.1 (75).



125LCR8TM93

- 5) After spreading loctite #242, assemble the M8 bolt (76).(3 pcs)
※ Tightening torque : $2.7 \pm 0.3 \text{ kgf} \cdot \text{m}$
※ After the assembly, instantly check the noise and interference by rotatong the gear.



125LCR8TM94

- 6) First, place bearing (60) on the ring gear (59), then put jig on it, then press it with press machine.



125LCR8TM95

- 7) After turning ring gear over, assemble bearing the same way.
※ Be care of nick and safety when turn ring gear over.



125LCR8TM96

- 8) Assemble folating seal assembly (61) by using the jig.
※ After assembling, wipe steel-lined section with alcohol.
※ Flatness deviation has to be less than 1 mm.

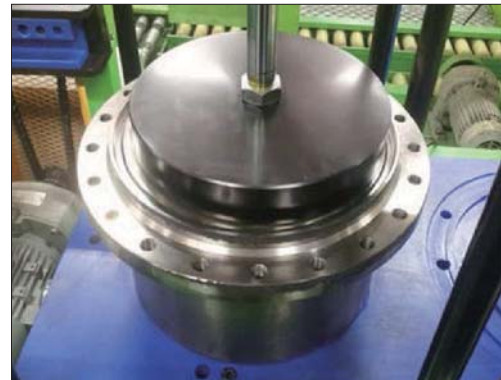

125LCR8TM97

- 9) Place folating seal assembly on the motor assembly then assemble it.
※ After assembling, wipe steel-lined section with alcohol.
※ Flatness deviation has to be less than 1 mm.



125LCR8TM98

- 10) After arriving safely ring gear assembly in the motor assembly, press it with press machine.
※ After press-fitting, clamp ring gear to fix it.
※ When using the press pay attention to bearing damage.



125LCR8TM99

14) Shrink fit the inner race No.2 (68).(4 pcs)

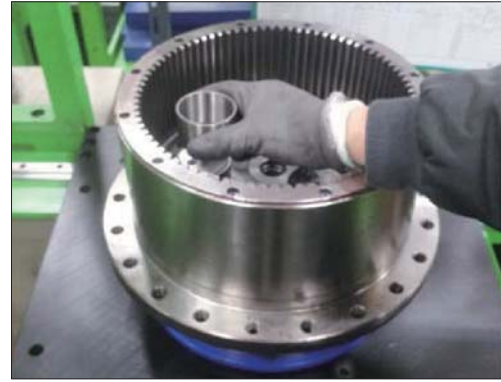

125LCR8TM104

15) Assemble thrust plate No.2 (69).(4 pcs)



125LCR8TM105

16) Assemble needle bearing No.2 (67).(4 pcs)



125LCR8TM106

17) Assemble planetary gear No.2 (66).(4 pcs)

※ Grooves of planetary gear will be facing up.



125LCR8TM107

18) Assemble thrust washer No.2 (65).(4 pcs)



125LCR8TM108

19) After spreading loctite #242, assemble the M10 bolt (64).(4 pcs)

※ Tightening torque : $5.5 \pm 0.6 \text{ kgf} \cdot \text{m}$
($39.8 \pm 4.3 \text{ lbf} \cdot \text{ft}$)



125LCR8TM109

20) Assemble sun gear No.2 (70).



125LCR8TM110

21) Assemble carrier No.1 assembly.



125LCR8TM111

22) Assemble sun gear No.1 (72).



125LCR8TM112

23) Spread the loctite #515 on the cover (80) with reference to the right detail view.

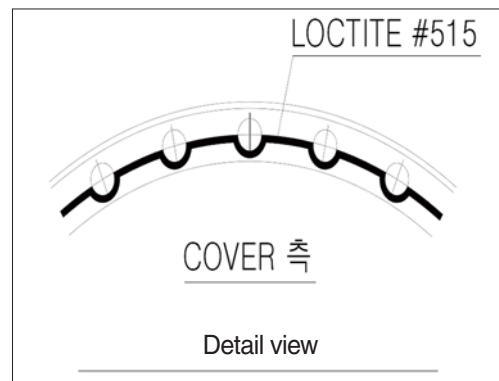

125LCR8TM114

24) Place cover (80) to fit the bolt holes.



125LCR8TM115

25) After spreading loctite #242, assemble the M10 bolt (81).(12 pcs)

※ Tightening torque : $6.3 \pm 0.7 \text{ kgf} \cdot \text{m}$
($45.6 \pm 5.1 \text{ lbf} \cdot \text{ft}$)



125LCR8TM116

26) Inject the 2.3 ± 0.3 liter gear oil to PF3/8 tap section.



125LCR8TM117

27) After assembling the O-ring (83) to the plug (82), assemble it to the cover. (3 pcs)

※ Tightening torque : 5.5 ± 0.5 kgf · m
(39.8 ± 3.6 lbf · ft)



125LCR8TM118

TRAVEL DEVICE (HIGH WALKER, TYPE1)

1. REMOVAL AND INSTALL

1) REMOVAL

- (1) Swing the work equipment 90 ° and lower it completely to the ground.
- (2) Operate the control levers and pedals several times to release the remaining pressure in the hydraulic piping.
- (3) Loosen the breather slowly to release the pressure inside the hydraulic tank.

▲ Escaping fluid under pressure can penetrate the skin causing serious injury.

- ※ When pipes and hoses are disconnected, the oil inside the piping will flow out, so catch it in oil pan.
- (4) Remove the track shoe assembly.
For details, see **removal of track shoe assembly**.
 - (5) Remove the cover.
 - (6) Remove the hose.
 - ※ Fit blind plugs to the disconnected hoses.
 - (7) Remove the bolts and the sprocket.
 - Tightening torque : 29.7 ± 3.0 kgf · m
(215 ± 21.7 lbf · ft)
 - (8) Sling travel device assembly (1).
 - (9) Remove the mounting bolts (2), then remove the travel device assembly.
 - Weight : 300 kg (660 lb)
 - Tightening torque : 25.7 ± 4.0 kgf · m
(166 ± 28.9 lbf · ft)

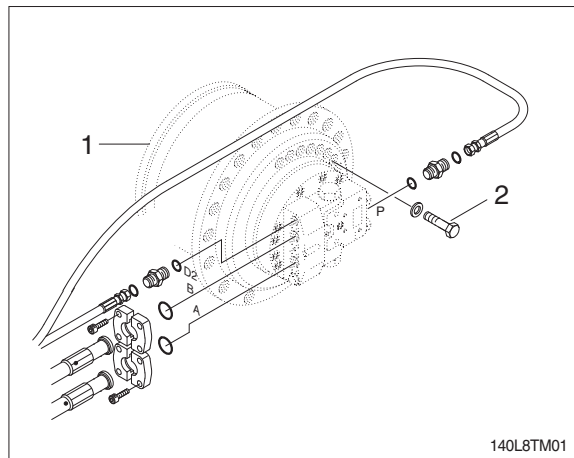

2) INSTALL

- (1) Carry out installation in the reverse order to removal.
- (2) Bleed the air from the travel motor.
 - ① Remove the air vent plug.
 - ② Pour in hydraulic oil until it overflows from the port.
 - ③ Tighten plug lightly.
 - ④ Start the engine, run at low idling, and check oil come out from plug.
 - ⑤ Tighten plug fully.
- (3) Confirm the hydraulic oil level and check the hydraulic oil leak or not.

2. TRAVEL MOTOR

1) STRUCTURE

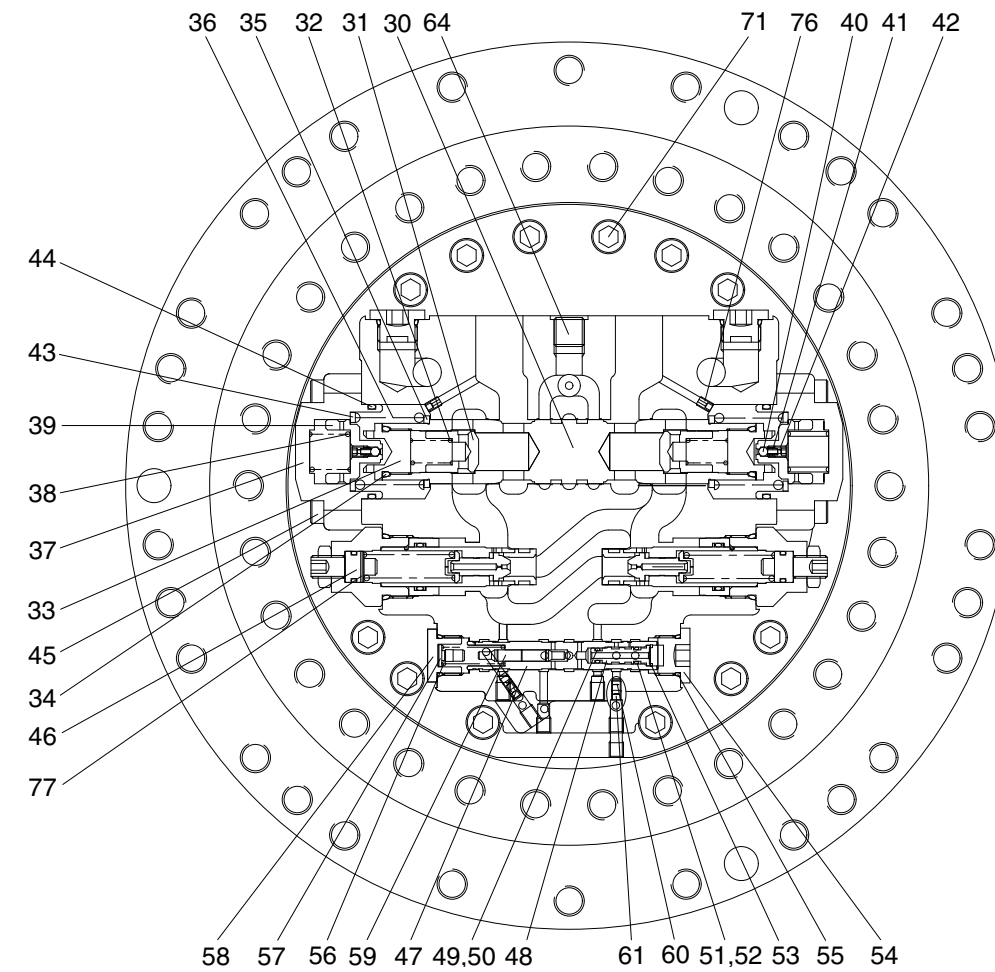
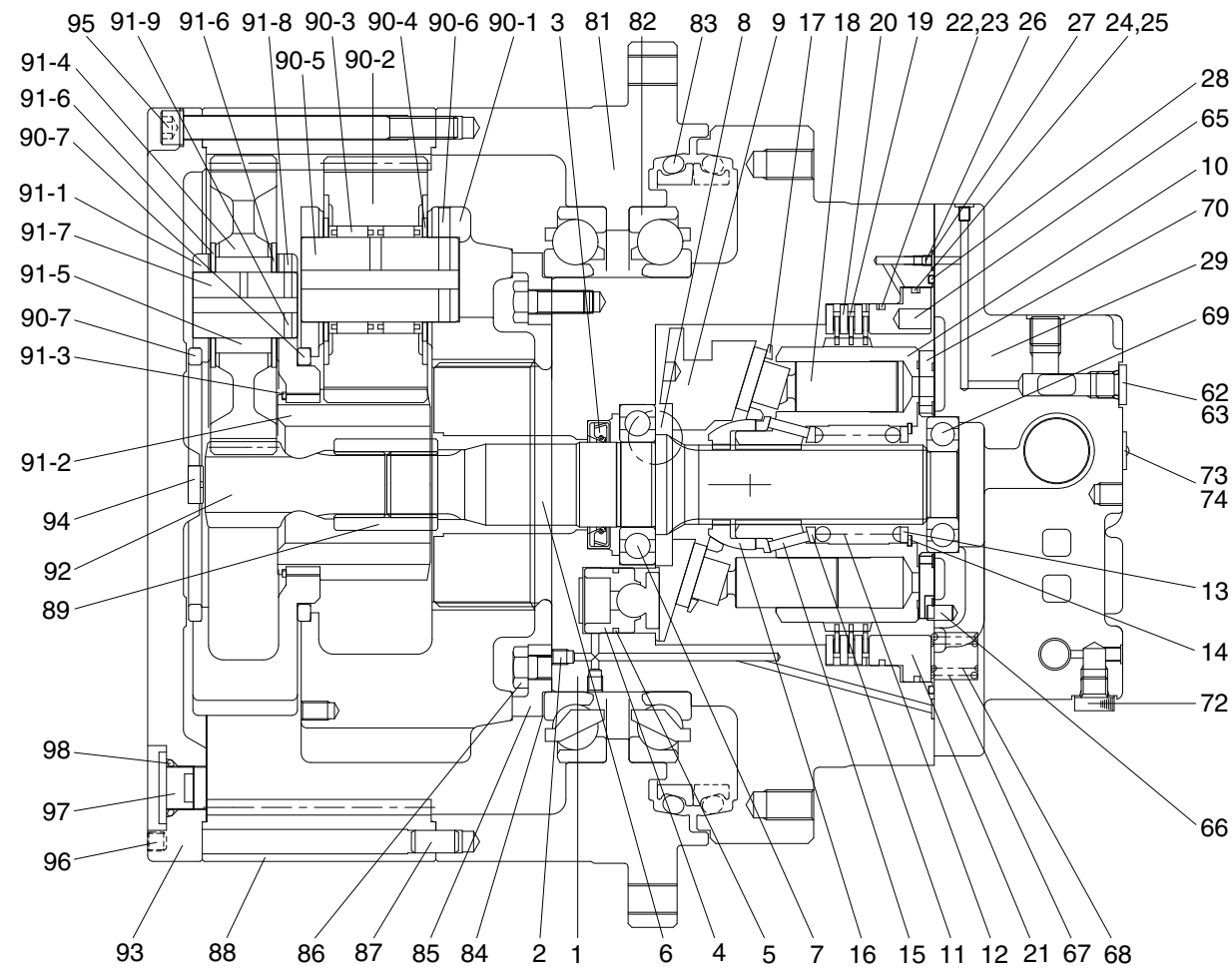

1 Shaft casing	20 Separate plate	39 Spool	58 Plug	77 Shim	91-1 Carrier No.1
2 Plug	21 Parking piston	40 Steel ball	59 Spool	81 Housing	91-2 Sun-gear No.2
3 Oil seal	22 O-ring	41 Spring	60 Orifice	82 Main bearing	91-3 Retaining ring
4 Swash piston	23 Back up ring	42 Plug	61 Orifice	83 Floating seal	91-4 Planetary gear No.1
5 Piston ring	24 O-ring	43 Spring seat	62 Plug	84 Shim	91-5 Needle bearing No.1
6 Shaft	25 Back up ring	44 O-ring	63 O-ring	85 Retainer	91-6 Thrust washer
7 Bearing	26 Orifice	45 Wrench bolt	64 Plug	86 Hex head bolt	91-7 Pin No.1
8 Steel ball	27 O-ring	46 Relief valve assy	65 Pin	87 Parallel pin	91-8 Spring pin
9 Swash plate	28 O-ring	47 Spool	66 Pin	88 Ring gear	91-9 Spring pin
10 Cylinder block	29 Rear cover	48 Guide	67 Spring	89 Coupling	92 Sun gear No.1
11 Spring seat	30 Spool	49 O-ring	68 Spring	90 Carrier assy No.2	93 Cover
12 Spring	31 Check	50 Back up ring	69 Bearing	90-1 Carrier No.2	94 Pad
13 End plate	32 Spring	51 O-ring	70 Valve plate	90-2 Planetary gear No.2	95 Hex socket head bolt
14 Snap ring	33 Plug	52 Back up ring	71 Wrench bolt	90-3 Needle bearing No.2	96 Hex socket Screw
15 Pin	34 O-ring	53 Snap ring	72 Plug	90-4 Thrust washer	97 Hydraulic plug
16 Ball guide	35 Spring seat	54 plug	73 Name plate	90-5 Pin No.2	98 O-ring
17 Set plate	36 Spring	55 O-ring	74 Rivet	90-6 Spring pin	99 Name plate
18 Piston assy	37 Cover	56 Spring	75 Seal kit	90-7 Thrust ring	
19 Friction plate	38 Spring	57 Spring seat	76 Orifice	91 Carrier assy No.1	

16092TM02

2) TOOLS AND TIGHTENING TORQUE

(1) Tools

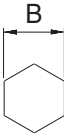
Tool name		Remark	
Allen wrench		2, 5, 4, 6, 10	
Socket for socket wrench, spanner	Socket	8, 14, 24, 27	
Torque wrench		Capable of tightening with the specified torques	
Pliers		-	
Plastic and iron hammer		Wooden hammer allowed. Normal 1 or so	
Monkey wrench		-	
Oil seal inserting jig		-	
Bearing pliers		-	
Seal tape		-	
Eye bolt		M10, M12, M14	
Press (0.5 ton)		-	
Oil stone		-	
Bearing assembling jig		-	

(2) Tightening torque

Part name	Item	Size	Torque	
			kgf · m	lbf · ft
Plug	2	NPT 1/16	1 ± 0.1	7.2 ± 0.7
Orifice	26	M5	0.7 ± 0.1	5 ± 0.7
Wrench bolt	45	M12 × 40	10 ± 1.0	72 ± 7.0
Relief valve	46	HEX 27	18 ± 1.0	130 ± 7.0
Plug	54	PF 1/2	8.5 ± 1.0	61 ± 7.0
Plug	58	HEX 24	5 ± 1.0	36 ± 7.0
Plug	62	PF 1/4	5 ± 1.0	36 ± 7.0
Wrench bolt	71	M12 × 35	10 ± 1.0	72 ± 7.0
Hex head bolt	-	M12 × 25	11 ± 1.5	79 ± 10
Hex socket head bolt	-	M12 × 155	11 ± 1.5	79 ± 10
Hex socket head plug	-	PF 3/4	19 ± 1	137 ± 7.0

3. OUTLINE OF DISASSEMBLING

1) GENERAL SUGGESTIONS

- (1) Select a clean place for dismantling.
Spread a rubber plate on a working table in order to prohibit the damage of parts.
- (2) Clean a deceleration equipment and a motor part, washing out dirt and unnecessary substances.
- (3) Without any damage of O-ring, oil seal, the adhered surface of other seals, a gear, a pin, the adhered surface of other bearings, and the surface of moisturized copper, treat each parts.
- (4) Numbers written in the parenthesis, (), next to the name of a part represent the part numbers of a cross-sectional view annexed with a drawing.
- (5) The side of a pipe in a motor can be written as a rear side; the side of out-put as a front side.
- (6) Using and combining a liquid gasket, both sides must be dried completely before spraying a liquid gasket.
- (7) In case of bonding bolts, combine a standard torque by torque wrench after spraying loctite 262 on the tab parts. (It can be dealt as assembling NPTF screws and an acceleration equipment.)

2) DISASSEMBLING

- (1) Unloosing wrench bolt and disassemble cover (37).
※ Wrench bolt = M12×40L-8 EA
(purchasing goods)

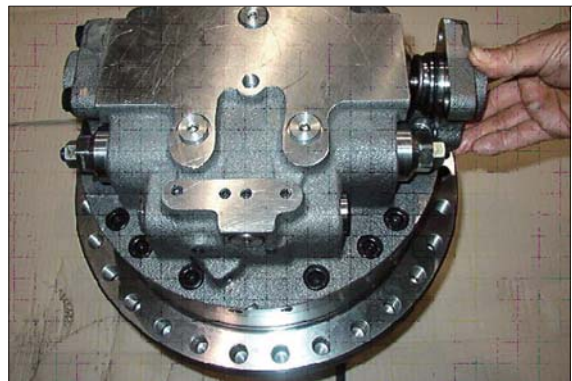

21078TM21

- (2) Disassemble parts related to counterbalance valve.



21078TM22

- (3) Unloosing wrench bolt (M12×35L, 16 EA) and disassemble rear cover assembly from motor assembly.

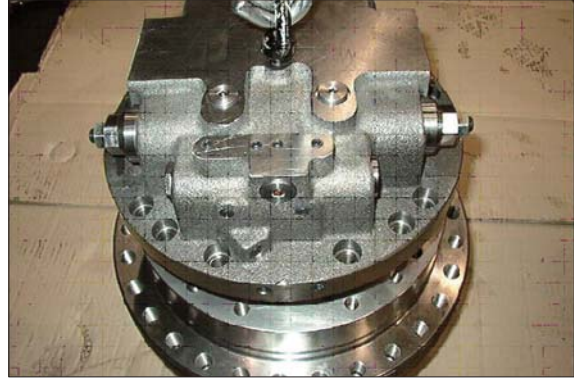

21078TM23



21078TM24

- (4) Dismantle packing piston (21) using compressed air.



21078TM25

- (5) Disassembly rotary kit from motor assembly (cylinder block assembly, piston assembly, ball guide, set plate, friction plate, steel plate...)

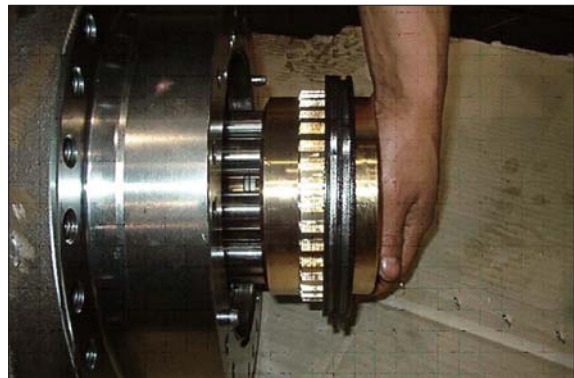

21078TM26

- (6) Using a jig, disassemble swash plate (9) from shaft casing.



21078TM27

- (7) Using compressed air, disassemble piston swash (4) piston ring (5), respectively.



21078TM28



21078TM29

- (8) Using a hammer, disassemble shaft (6) from shaft casing (1).

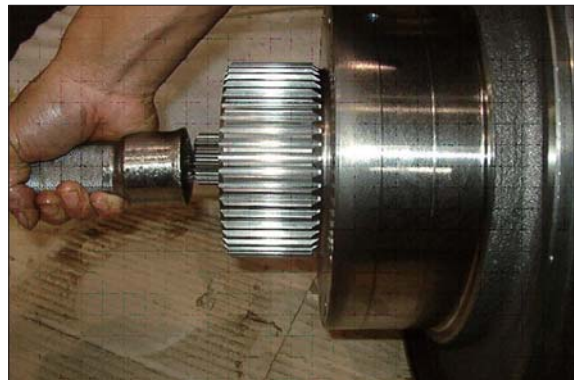

21078TM30

■ Disassemble cylinder sub.

- (9) Disassemble cylinder block assembly, piston assembly (9) and seat plate (M).



21078TM31



21078TM32

- (10) Disassemble ball guide (16), ring and pin (15) from cylinder block, respectively.



21078TM33



21078TM34



21078TM35

(11) Pushing spring (12) by an assembling jig, disassemble snap ring (14), spring seat (13), spring (12) and spring seat (11), respectively.



21078TM36



21078TM37

■ Disassemble valve casing sub.

(12) Using an hexagon wrench, unloosing wrench bolt (45) and disassemble cover (37), spring (38), spool (39), spring seat (43), spring (36) and spring seat (35), respectively.
(same balance on both sides)

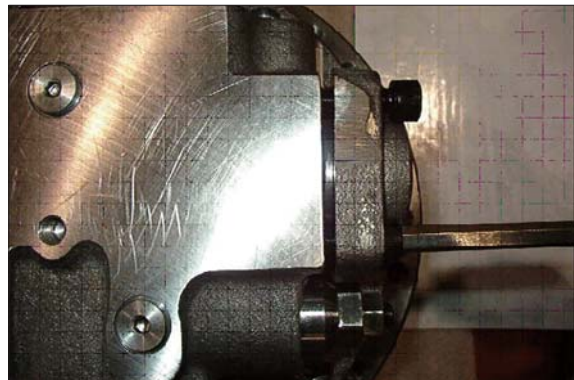

21078TM38



21078TM39

(13) Disassemble spool (59), spool (47), O-ring (51), guide (48) and snap ring (53) on rear cover, respectively.

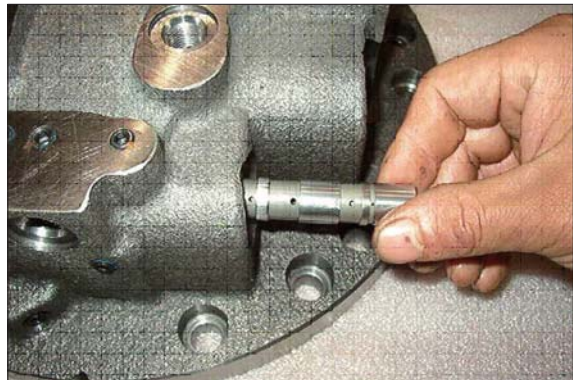

21078TM40



21078TM41

(14) Using a torque wrench, disassemble relief valve assembly (46) on rear cover.



21078TM42

4. OUTLINE FOR ASSEMBLING

1) GENERAL SUGGESTIONS

- (1) After washing each parts cleanly, dry it with compressed air.
Provided that you do not wash friction plate with treated oil.
- (2) In bonding each part, fasten bond torque.
- (3) When using a hammer, do not forget to use a plastic hammer.

2) ASSEMBLING

■ Assemble the sub of turning axis

- (1) Using a jig, assemble oil seal (3) into shaft casing (1)

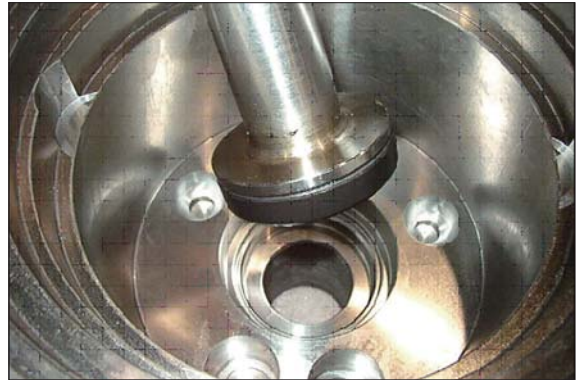

21078TM43

- (2) Have a bearing (8) thermal reacted into shaft (6).



21078TM44



21078TM45



21078TM46

- (3) Using a jig, assemble shaft assembly into shaft casing (1).



21078TM47

- (4) After spreading grease on steel ball (8) assemble into shaft casing (1).



21078TM48

- (5) Assemble swash piston assembly (4, 5) into shaft casing (1).



21078TM49

- (6) Assemble swash plate (9) into shaft casing (1).

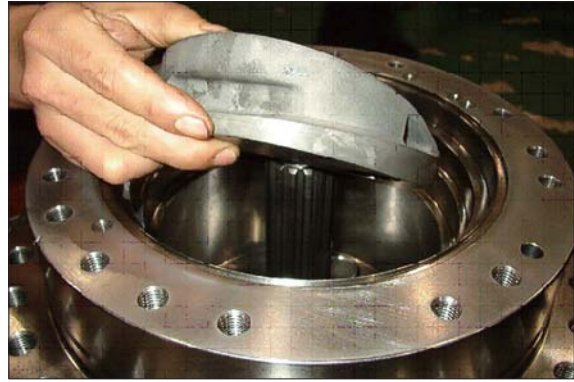

21078TM50

■ Assemble cylinder block sub.

- (7) Assemble spring seat (13), spring (12), spring seat (11) into cylinder block (10) respectively, pushing spring (12) using by a jig, assemble snap ring (14) with a snap ring (14).



21078TM51



21078TM52

(8) Assemble ring, pin (15) on cylinder block (10) ball guide (16) respectively.

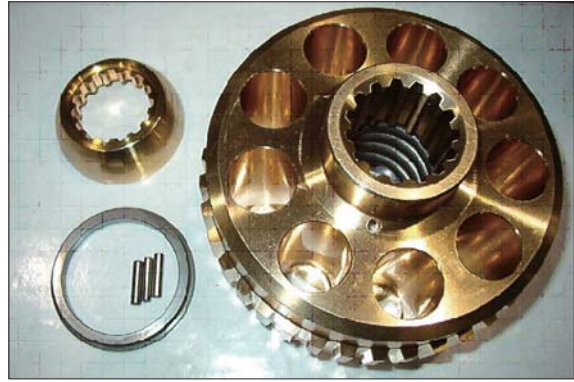

21078TM53



21078TM54

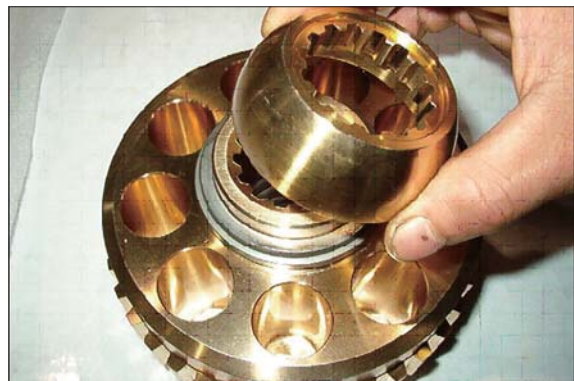

21078TM55

(9) Assemble cylinder block assembly, piston assembly (9), seat plate (17).



21078TM56

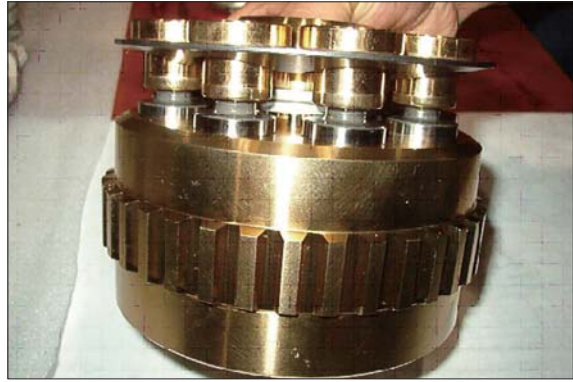

21078TM57

(10) Assemble cylinder block assembly (9) into shaft casing (1).

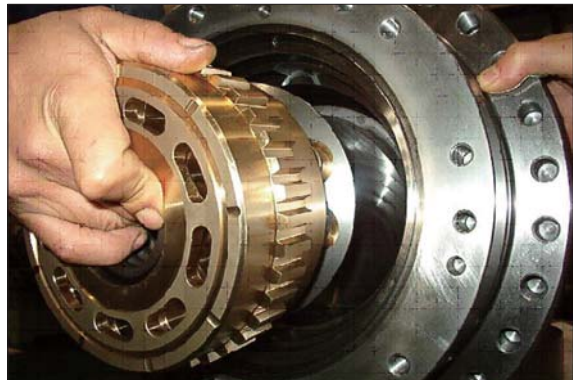

21078TM58

(11) Assemble friction plate (19) and plate (20) into shaft casing (1) respectively, prepare 6 set.



21078TM59



21078TM59-1

(12) Assemble O-ring (22, 23) into packing piston (21).



21078TM60

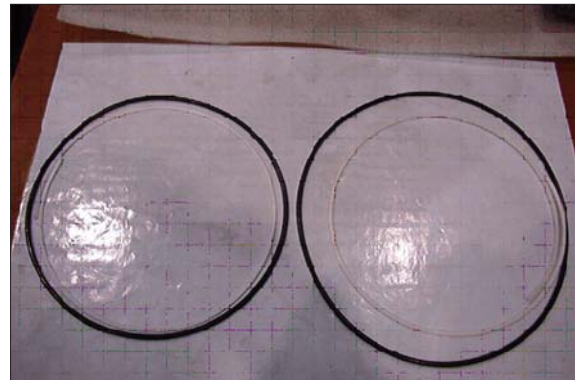

21078TM60-1

(13) After spreading grease on packing piston (21) bond wrench bolt and assemble shaft casing (1).



21078TM61

■ Assemble rear cover sub.

(14) Using a jig, assemble bearing (69) into rear cover (29).



21078TM62

(15) After assembling spool (59), spool (47), O-ring (51), guide (48) and snap ring (53) respectively into rear cover (29). Using torque wrench, assemble it.



21078TM63

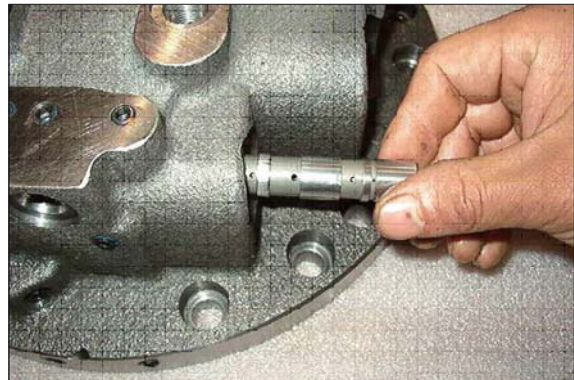

21078TM64

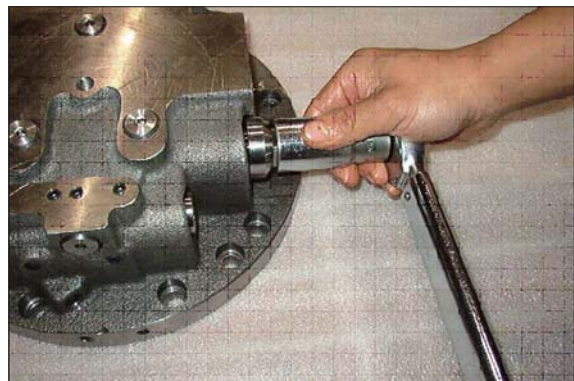

21078TM65

(16) Assemble spring seat (35), spring (36), spring seat (43), spool (39), spring (38), cover (37) respectively and assemble wrench bolt (45).
(same balance on both sides)

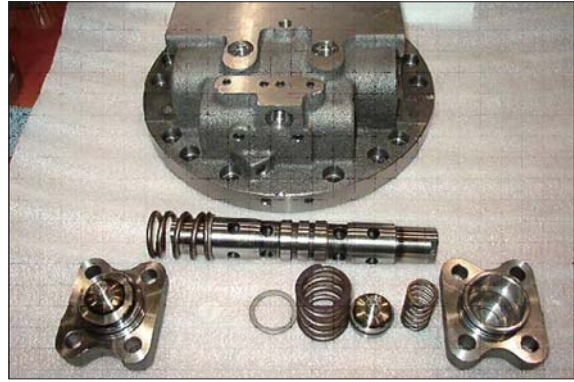

21078TM66

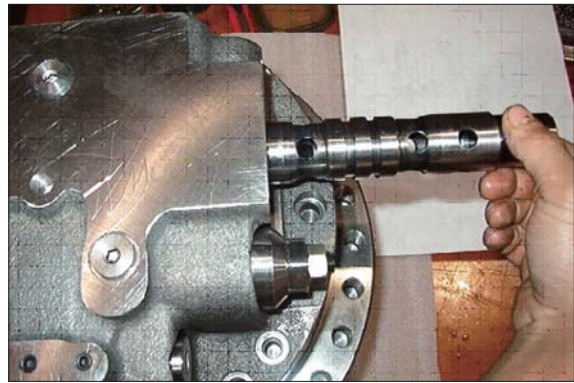

21078TM67

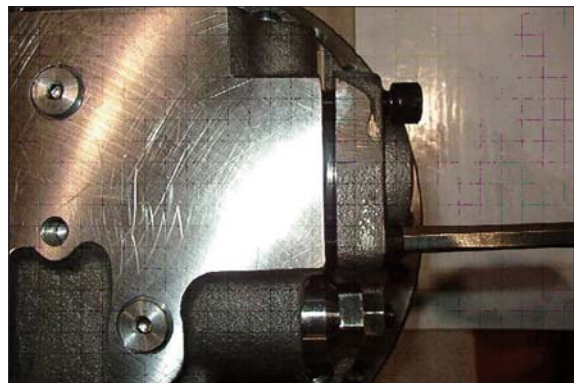

21078TM67-1

(17) Assemble plug (2).

※Plug (NPT1/16) - 11 EA



21078TM68



21078TM69

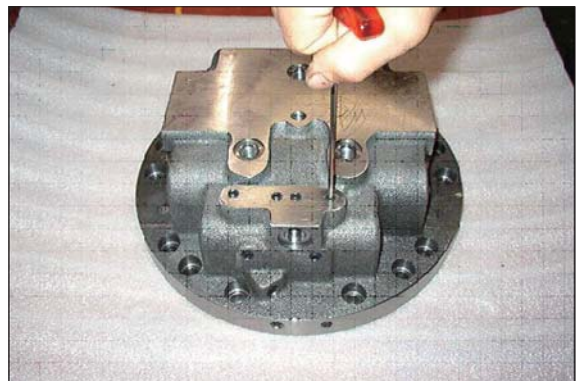

21078TM70



21078TM71

(18) Assemble plug (64).

※Plug (PT3/8) - 11 EA



21078TM72

(19) Assemble plug (62, 63) into rear cover (29) and assemble relief valve assembly.

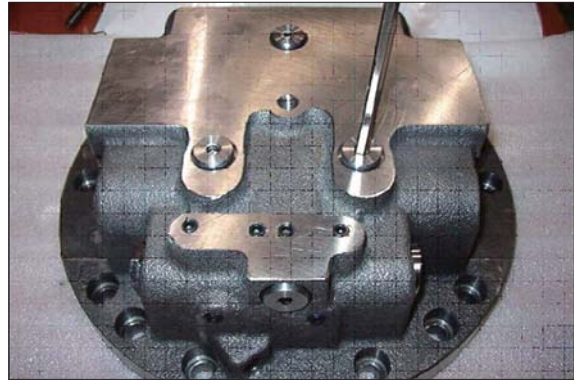

21078TM73

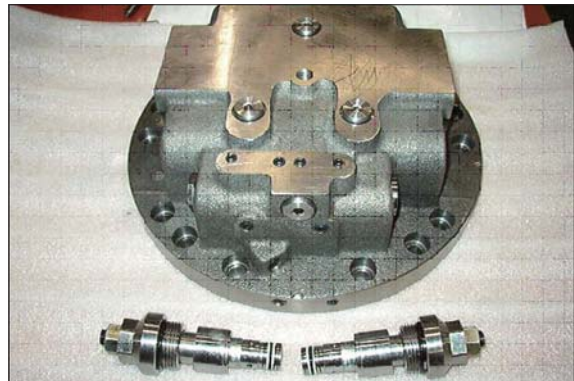

21078TM74

(20) Put spring (67, 68) together into rear cover (29), prepare 6 set.



21078TM75



21078TM76

(21) Assemble valve plate (70) into rear cover (29).

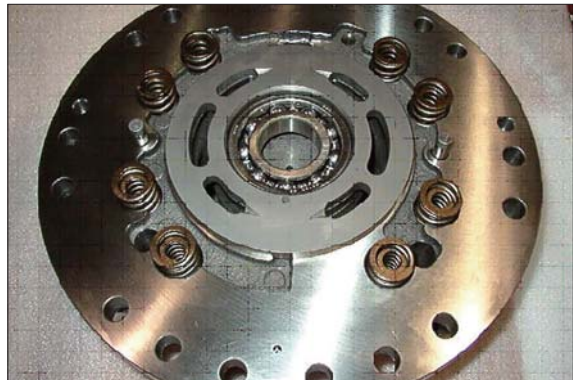

21078TM77

(22) After assembling shaft casing (1) and rear cover (29).
Assemble spool assembly (30), spring (38), spool (39), cover (37) after then complete assembly with wrench bolt (45).

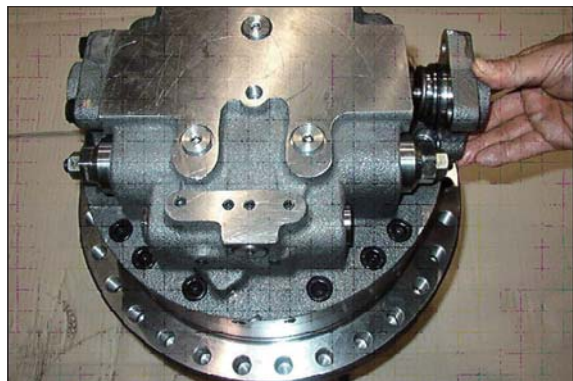

21078TM78

(23) Finish assembly.



21078TM79

5. DISASSEMBLING REDUCTION UNIT

1) PREPARATION FOR DISASSEMBLING

- (1) The reduction units removed from excavator are usually covered with mud. Wash outside of propelling unit and dry it.
- (2) Locate reducer in order for drain port to be at the lowest level loosen taper screw plug of drain port, and drain oil from reduction gear.
 - ※ While oil is still hot, inside of the unit may be pressurized.

▲ Take care of the hot oil gushing out of the unit when loosening the plug.

(3) Mark for mating

Put marks on each mating parts when disassembling so as to reassemble correctly as before.



21078TM80

2) SETTING REDUCTION UNIT (OR WHOLE PROPELLING UNIT) ON WORK STAND FOR DISASSEMBLING

- (1) Remove M12 hexagon socket head bolts (95) at 3 places from cover (93) almost equally apart each other, and then install M12×155L eye bolts. Lift up the unit using them and place it on work stand with cover upward.

▲ Take great care not to pinch your hand between parts while disassembling nor let fall parts on your foot while lifting them.



21078TM81

3) REMOVING COVER

- (1) Remove the rest of M12 hexagon socket head bolts (95) that securing gear and housing. Loosen all the socket bolts and then, disassemble cover.
- (2) As the cover (93) is adhered to ring gear (88), disassemble ring gear (88) and cover (93) by lightly hammering slantwise upward using sharpened punch inserted between the cover and ring gear.

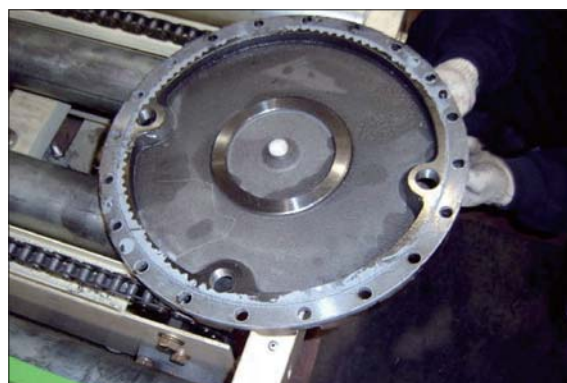

21078TM82

4) REMOVING NO.1 CARRIER SUB ASSEMBLY

- (1) Screw three M10 eye-bolt in No.1 carrier and lift up and remove No.1 carrier Assy.



21078TM83

- (2) Remove No.1 sun gear

- ※ Be sure to maintain it vertical with the ground when disassembling No.1 sun gear.



21078TM84

5) REMOVING NO.2 CARRIER SUB ASSEMBLY

- (1) Screw three M10 eye-bolt in No.2 carrier and lift up and remove No.2 carrier Assy.



21078TM85

- (2) Remove No.2 sun gear

- ※ Be sure to maintain it vertical with the ground when disassembling No.2 sun gear.

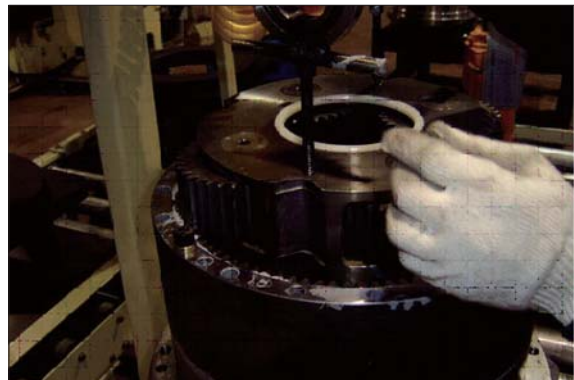

21078TM86

6) REMOVING RING GEAR

- (1) As the ring gear (88) is adhered to housing (81), disassemble ring gear (88) and housing (81) by lightly hammering slantwise upward using sharpen punch inserted between the ring gear and housing.
 - ※ Carefully disassembling ring gear not to make scratch on it.
- (2) Screw M14 eye-bolt in ring gear and lift up and remove it.

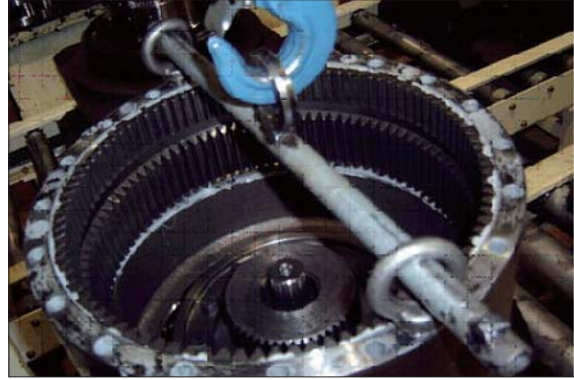

21078TM87

7) REMOVING COUPLING

- (1) Remove coupling.

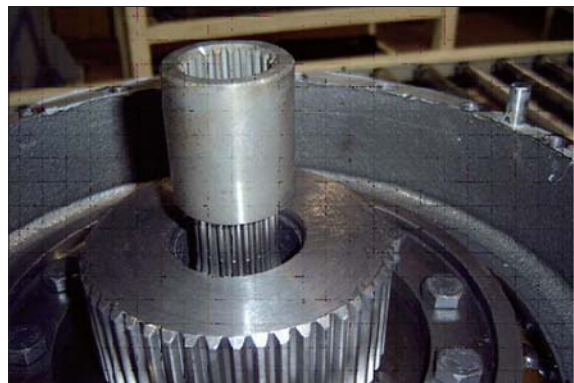

21078TM88

8) REMOVING RETAINER & SHIM

- (1) Remove M12 hexagon socket head bolts that secure retainer and motor.
- (2) Remove retainer & shim.

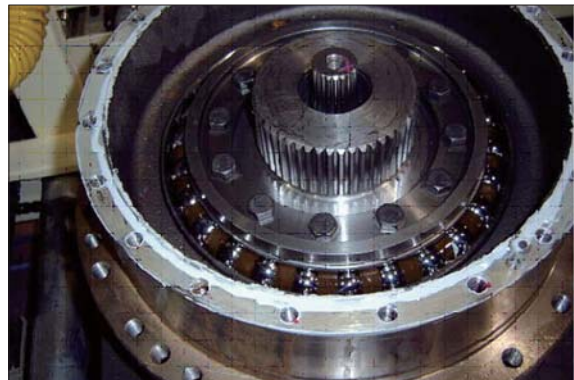

21078TM89

9) REMOVING HOUSING SUB ASSEMBLY

- (1) Screw M12 eye bolt in housing and lift up housing assembly including angular bearing and floating seal.

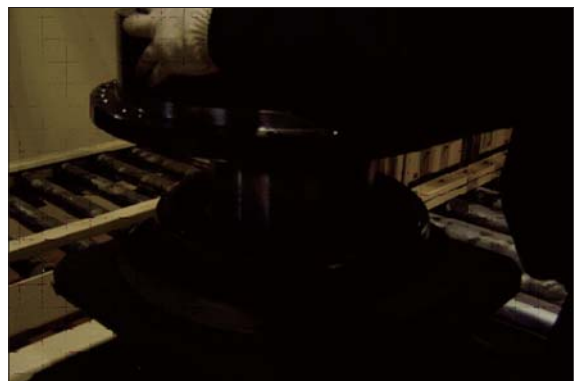

21078TM90

10) REMOVING FLOATING SEAL

- (1) Lift up a piece of floating seal of motor side.



21078TM91

11) DISASSEMBLING HOUSING ASSEMBLY

- (1) After turning housing, lift up a piece of floating seal from housing and then remove it.
- ※ Don't disassemble angular bearing.

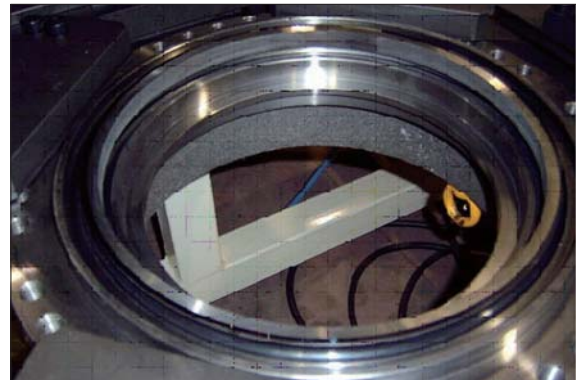

21078TM92

12) DISASSEMBLING NO.1 CARRIER

- (1) Remove thrust ring (90-7) from carrier.
- (2) Knock spring pin (91-8) fully into No.1 pin (91-7).
- (3) Remove planetary, thrust washer, No.1 pin, bearing from carrier.

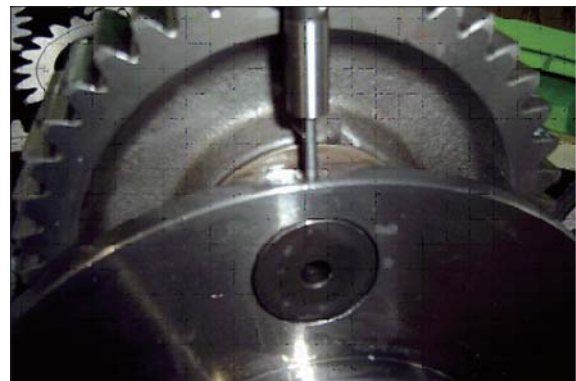

21078TM93



21078TM94



21078TM95

13) DISASSEMBLING NO.2 CARRIER

- (1) Disassemble No.2 carriers, using the same method for No.1 carrier assembly.



21078TM96



21078TM97

6. ASSEMBLY REDUCTION GEAR

1) GENERAL NOTES

Clean every part by kerosene and dry them by air blow.

Surfaces to be applied by locktite must be decreased by solvent.

Check every part for any abnormal.

Each hexagon socket head bolt should be used with locktite No. 262 applied on its threads.

Apply gear oil slightly on each part before assembling.

Take great care not to pinch your hand between parts or tools while assembling nor let fall parts on your foot while lifting them.

Inspection before reassembling

Thrust washer

- Check if there are seizure, abnormal wear or uneven wear.
- Check if wear is over the allowable limit.

Gears

- Check if there are pitting or seizure on the tooth surface.
- Check if there are cracks on the root of tooth by die check.

Bearings

- Rotate by hand to see if there are something unusual such as noise or uneven rotation.

Floating seal

- Check flaw or score on sliding surfaces or O-ring.

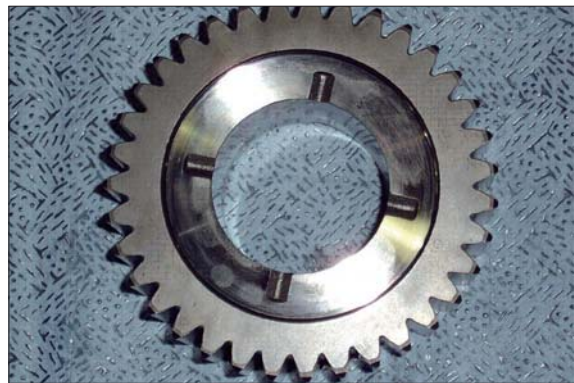

21078TM98

2) ASSEMBLING NO.1 CARRIER

(1) Put No.1 carrier (91-1) on a flat place.

(2) Install No.1 needle bearing (91-5) into No.1 planetary gear (91-4), put 2 EA of No.1 thrust washer (91-6) on both sides of bearing, and then, install it into carrier.



21078TM99

- (3) Install No.1 pin (91-5) into No.1 carrier where the holes for No.1 pin (91-5) are to be in line with those of No.1 carrier, and then, install spring pins into the holes.



21078TM100

- (4) Caulk carrier holes as shown on the picture.
 (5) Assemble thrust ring (90-7) into carrier.



21078TM101

3) ASSEMBLING NO.2 CARRIER

- (1) Put No.2 carrier (90-1) on a flat place.
 (2) Install No.2 needle bearing (90-3) into No.2 planetary gear (90-2), put 2 EA of No.2 thrust washer (90-4) on both sides of bearing, and then, install it into carrier.

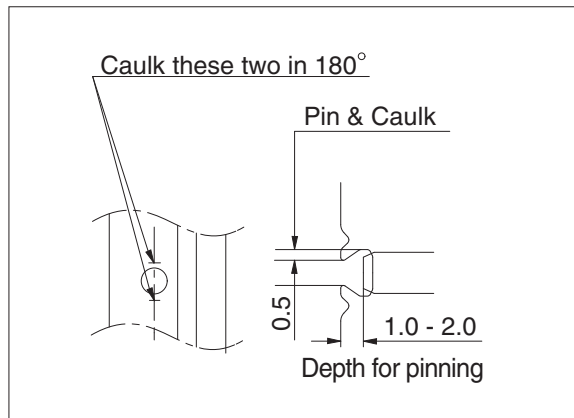

21078TM102

- (3) Install No.2 pin (90-5) into No.2 carrier where the holes for No.2 pin (90-5) are to be in line with those of No.2 carrier, and then, install spring pins into the holes.



21078TM103

- (4) Caulk carrier holes as shown on the picture.
- (5) Assembly thrust ring (90-7) into carrier.



21078TM104

4) ASSEMBLING FLOATING SEAL (83) AND MAIN BEARING (82)

- (1) Assemble floating seal into motor by use of pressing jig. Grease the contact parts for floating seal which is assembled into motor.
- (2) Heat bearing at 60~70°C and then, put into the motor side.

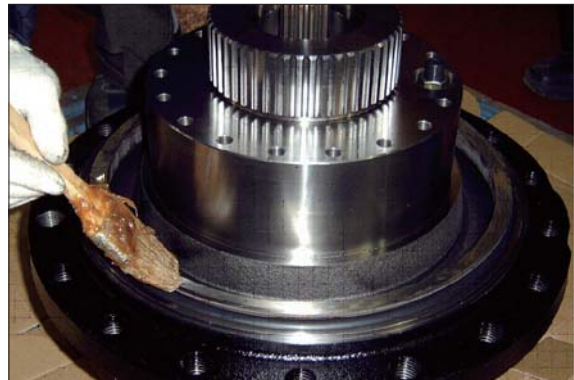

21078TM105

- ※ Be sure to maintain it vertical with the ground when assembling bearing and floating seal.



21078TM106

5) ASSEMBLING HOUSING

- (1) Heat housing at 60~70°C while clearing it out and then, assemble floating seal into housing by use of pressing jig.
- ※ Be sure to maintain it vertical with the ground when assembling floating seal.



21078TM705

6) INSTALLING HOUSING ASSEMBLY

- (1) Install 2 EA of M12 eye-bolt into housing assembly.
 - (2) Assemble housing into motor by use of hoist and eye-bolt.
- ※ Be sure to tighten eye-bolt deep enough.



21078TM108

7) INSTALLING MAIN BEARING (82)

- (1) Heat main bearing at 60~70 °C and then, install.
- ※ Be sure to maintain it vertical with the ground when assembling bearing.

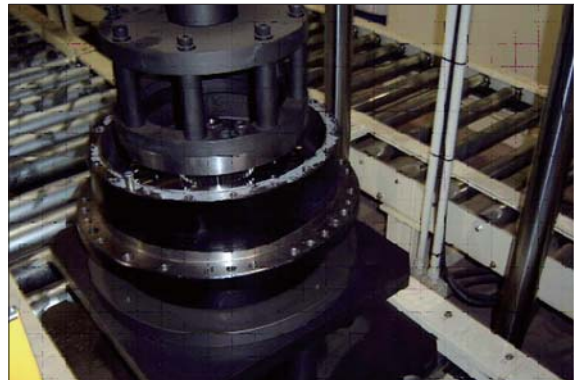

21078TM109

8) INSTALLING RETAINER (85) AND SHIM (84)

- (1) Measure clearance between main bearing and retainer by use of jig to decide the thickness of shim and select an appropriate shim, and then, assemble retainer.
- (2) Apply locktite (#262) on M12 hexagon head bolt, and then, bolt.

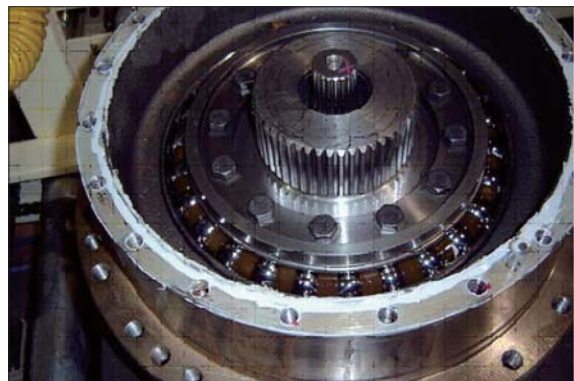

21078TM110

9) INSTALLING COUPLING

- (1) Install coupling on spline of the motor.

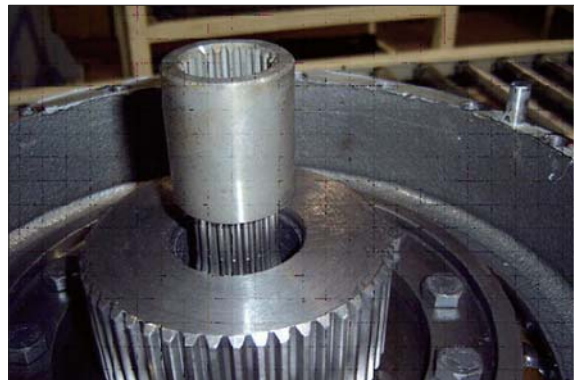

21078TM111

10) INSTALLING RING GEAR

- (1) Apply three bone #1104 (loctite #515) on housing for ring gear without gap.
- (2) Insert lock pin into housing hole.
- (3) Install M14 eye-bolt on the tap of ring gear.
- (4) Lift ring gear and then, assemble into housing in order for hole of ring gear and parallel pin of housing to be in line.
- (5) Temporarily secure 4EA of M12 hexagon socket bolt and shim with cover thickness having appropriate torque.

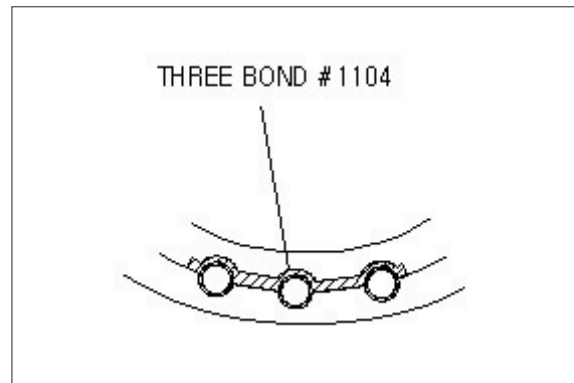

21078TM112A

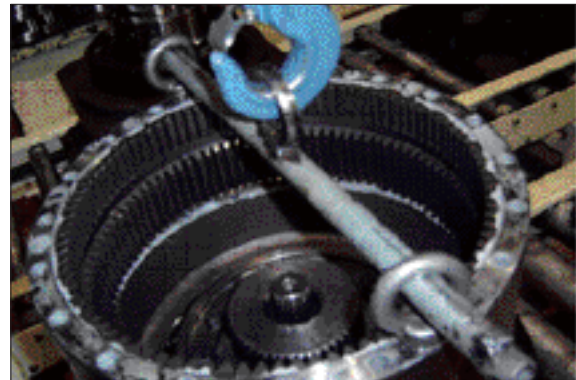

21078TM113

11) INSTALLING NO.2 CARRIER SUB ASSEMBLY

- (1) Install M10 eye-bolt on No.2 carrier assembly.
- (2) Lift No.2 carrier assembly and then, slowly put it down on ring gear.
- (3) Rotate planetary gear by hands and install on ring gear.



21078TM114

12) INSTALLING NO.2 SUN GEAR (91-2)

- (1) Install No.2 sun gear on the spline of No.2 carrier and No.2 planetary gear, matching teeth of them.



21078TM115

- (2) Install No.2 sun gear on the spline of No.2 carrier and No.2 planetary gear, matching teeth of them.

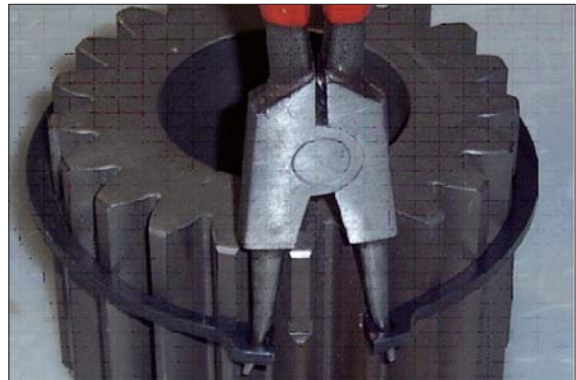

21078TM116

13) INSTALLING NO.1 CARRIER SUB ASSEMBLY

- (1) Install M10 eye-bolt on No.2 carrier assembly.
- (2) Lift No.1 carrier assembly and then, slowly put it down on ring gear.
- (3) Rotate planetary gear by hands and install on ring gear.



21078TM117

14) INSTALLING NO.1 SUN GEAR (92)

- (1) Put down No.1 sun gear on No.1 carrier, maintaining it vertical with spline of coupling.
- (2) Install No.1 sun gear on No.1 planetary gear, matching their teeth.



21078TM118

15) INSTALLING COVER (93)

- (1) Beat pad (94) with plastic hammer, and press it into the center of cover.
- (2) Apply three bond #1104, loctite (#515) on the ring gear for cover without gap.
- (3) Put cover on ring gear, apply loctite (#262) on M12 hexagon socket head bolt, and then, bolt.

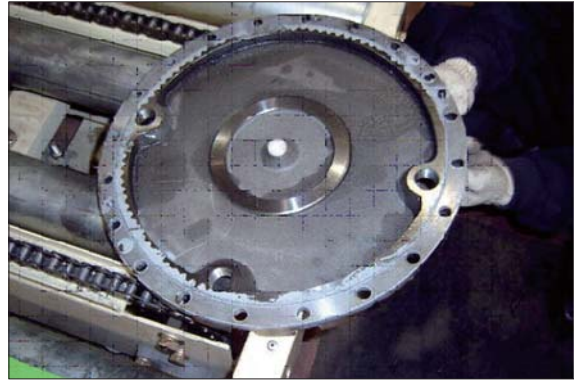

21078TM119

- (4) Fill gear oil (5.8 liter) into drain port.
- (5) Apply gear oil on PF3/4 hydraulic plug (97) and then, bolt.



21078TM120

GROUP 7 RCV LEVER

1. REMOVAL AND INSTALL

1) REMOVAL

- (1) Lower the work equipment to the ground and stop the engine.
- (2) Operate the control levers and pedals several times to release the remaining pressure in the hydraulic piping.
- (3) Loosen the breather slowly to release the pressure inside the hydraulic tank.

▲ Escaping fluid under pressure can penetrate the skin causing serious injury.

- (4) Loosen the socket bolt (1).
 - Tightening torque : $2.5 \pm 0.5 \text{ kgf} \cdot \text{m}$
($18.1 \pm 3.6 \text{ lbf} \cdot \text{ft}$)
- (5) Remove the cover of the console box.
- (6) Disconnect pilot line hoses (3).
- (7) Remove the pilot valve assembly (2).
 - ※ When removing the pilot valve assembly, check that all the hoses have been disconnected.

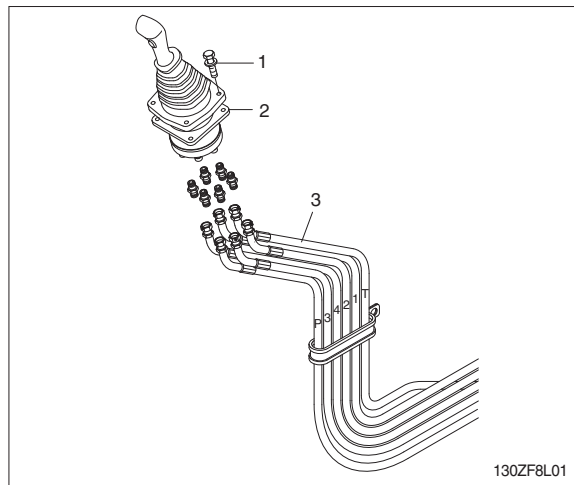

2) INSTALL

- (1) Carry out installation in the reverse order to removal.
- (2) Confirm the hydraulic oil level and check the hydraulic oil leak or not.

2. DISASSEMBLY AND ASSEMBLY

1) STRUCTURE

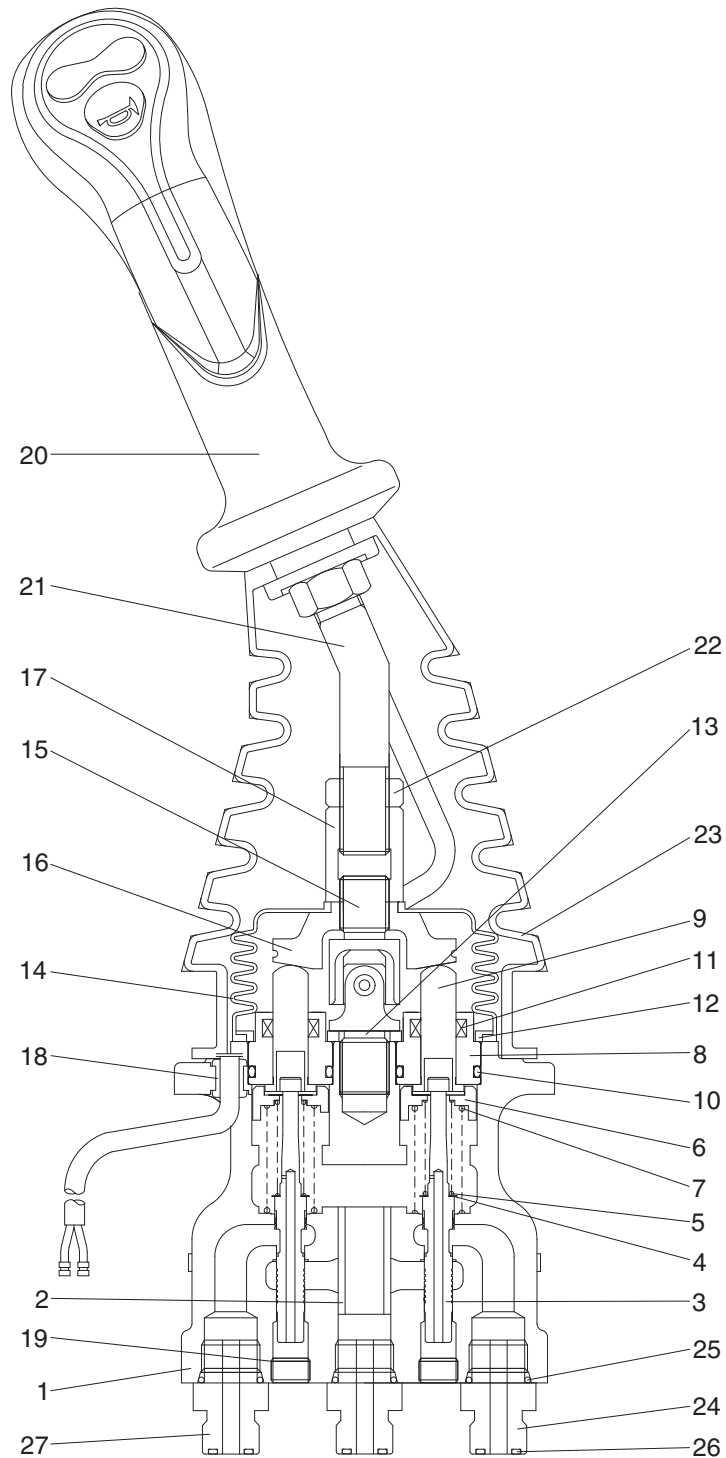

300L2RL06

1	Case	8	Plug	15	Joint assembly	22	Nut
2	Bushing	9	Push rod	16	Swash plate	23	Boot
3	Spool	10	O-ring	17	Adjusting nut	24	Last guard filter
4	Shim	11	Rod seal	18	Bushing	25	O-ring
5	Spring	12	Plate	19	Plug	26	O-ring
6	Spring seat	13	Spacer	20	Handle assembly	27	Connector
7	Spring	14	Boot	21	Handle bar		

2) TOOLS AND TIGHTENING TORQUE

(1) Tools

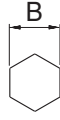
Tool name	Remark	
Allen wrench	6	
Spanne	22	
	27	
(+) Driver	Length 150	
(-) Driver	Width 4~5	
Torque wrench	Capable of tightening with the specified torques	

(2) Tightening torque

Part name	Item	Size	Torque	
			kgf · m	lbf · ft
Joint	15	M14	3.5	25.3
Swash plate	16	M14	5.0±0.35	36.2±2.5
Adjusting nut	17	M14	5.0±0.35	36.2±2.5
Lock nut	22	M14	5.0±0.35	36.2±2.5

3) DISASSEMBLY

※ Procedures are based on the type M1.

- (1) Clean pilot valve with kerosene.
 - ※ Put blind plugs into all ports
- (2) Fix pilot valve in a vise with copper (or lead) sheets.
- (3) Remove end of boot (23) from case (1) and take it out upwards.

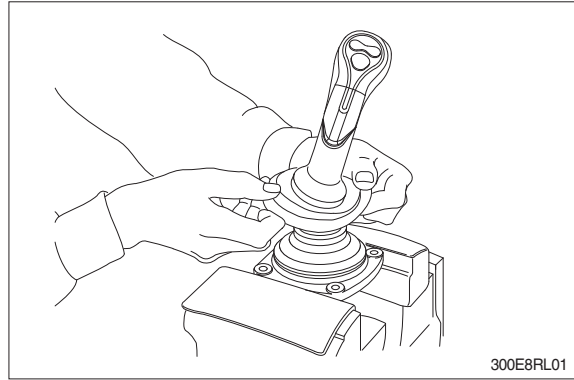

※ For valve with switch, remove cord also through hole of casing.

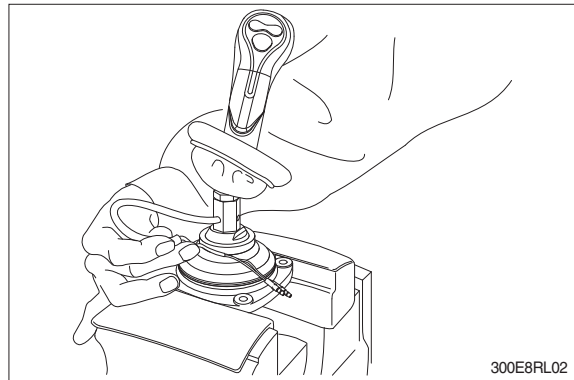

- (4) Loosen lock nut (22) and adjusting nut (17) with spanners on them respectively, and take out handle section as one body.

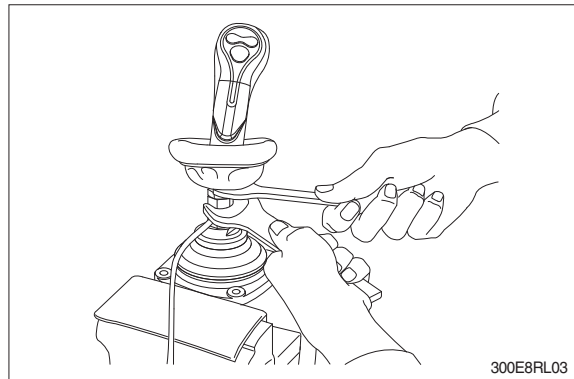

- (5) Remove the boot (14).

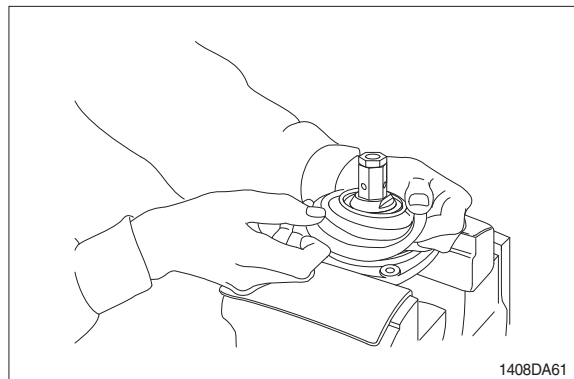

- (6) Loosen adjusting nut (17) and swash plate (16) with spanners on them respectively, and remove them.

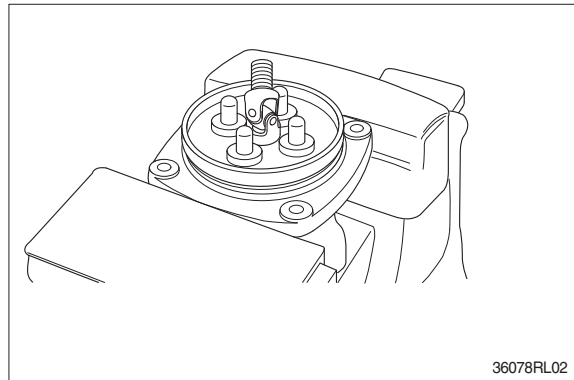
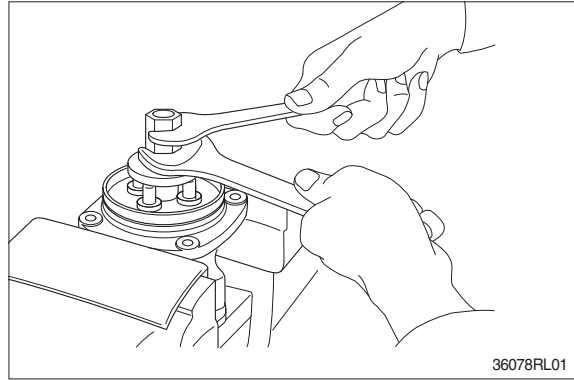

- (7) Turn joint anticlockwise to loosen it, utilizing jig (Special tool).

- ※ When return spring (7) is strong in force, plate (12), plug (8) and push rod (9) will come up on loosening joint. Pay attention to this.

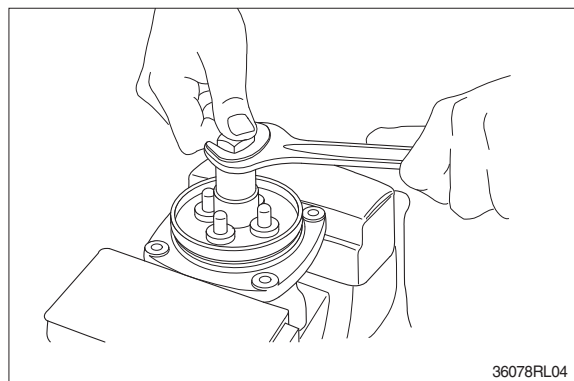
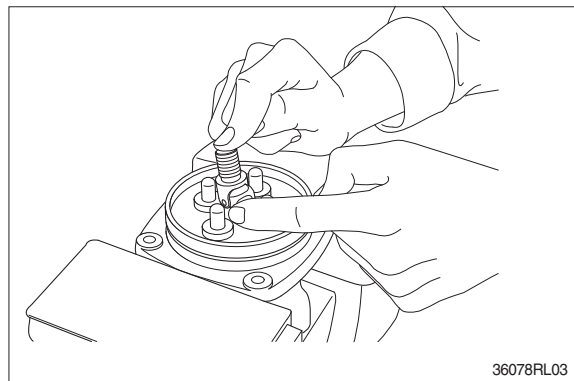

(8) Remove plate (12).

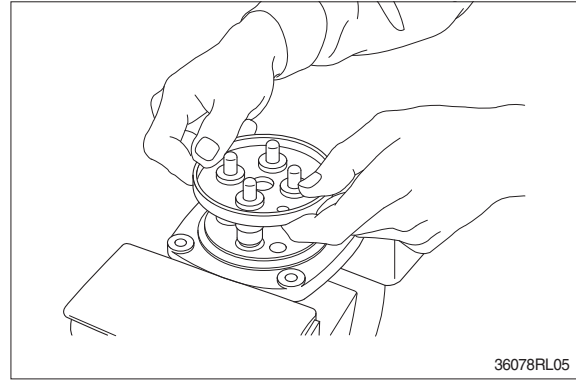

(9) When return spring (7) is weak in force, plug (8) stays in casing because of sliding resistance of O-ring.

- ※ Take it out with minus screwdriver. Take it out, utilizing external periphery groove of plug and paying attention not to damage it by partial loading.
- ※ During taking out, plug may jump up due to return spring (7) force. Pay attention to this.

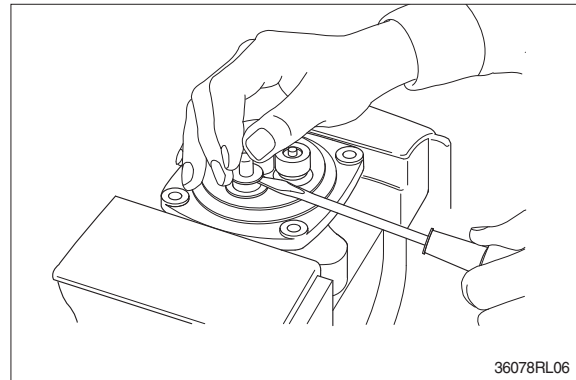

(10) Remove reducing valve subassembly and return spring (7) out of casing.

- ※ Record relative position of reducing valve subassembly and return springs.

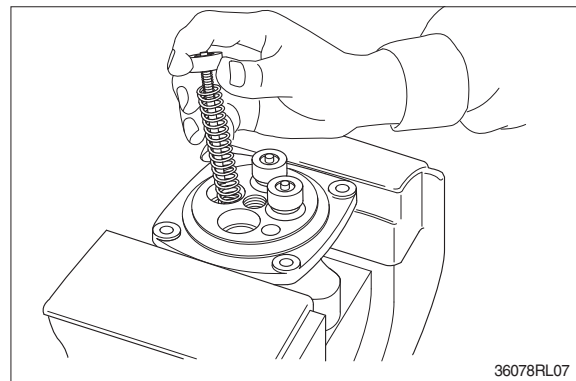

(11) Separate spool (3), spring seat (6), spring (5) and shim (4) individually.

- ※ Pay attention not to damage spool surface.
- ※ Record original position of spring seat (6).
- ※ Until being assembled, they should be handled as one subassembly group.

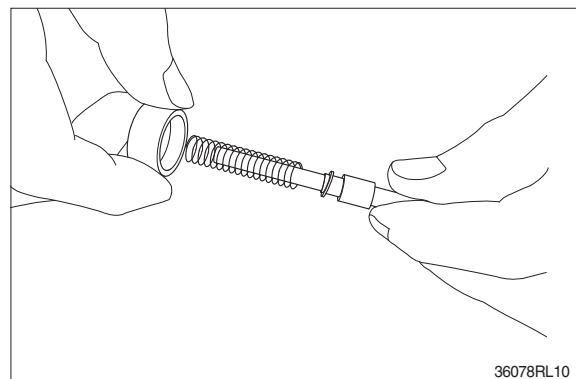

(12) Take push rod (9) out of plug (8).

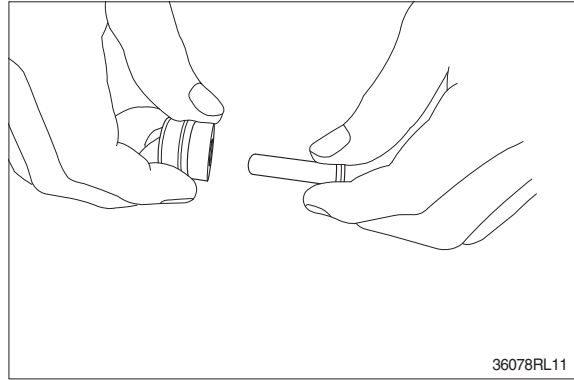

(13) Remove O-ring (10) and seal (11) from plug (8).
Use small minus screwdriver or so on to remove this seal.

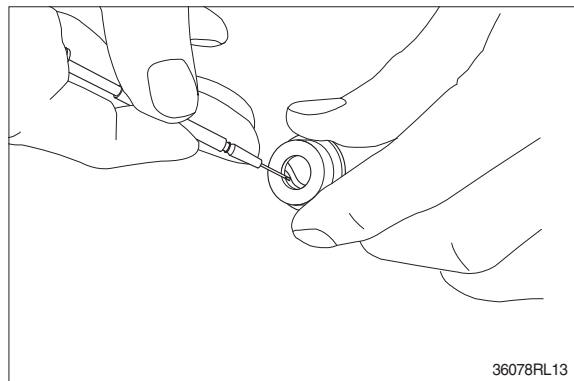
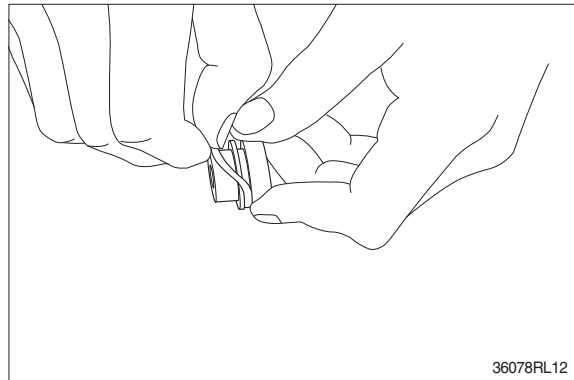

(14) Remove lock nut (22) and then boot (23).

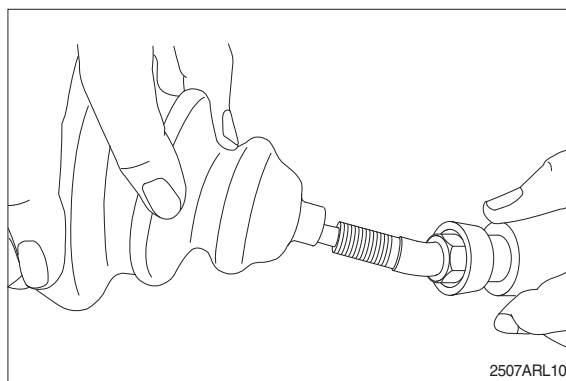
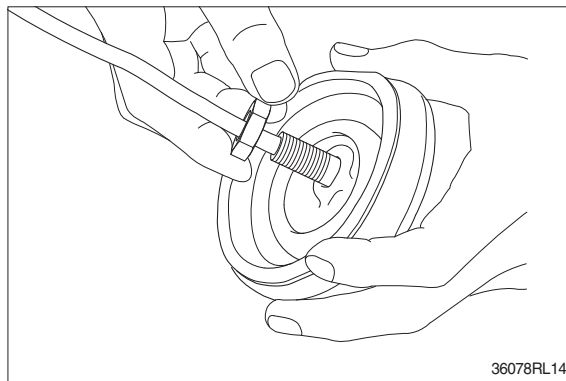

(15) Cleaning of parts

- ① Put all parts in rough cleaning vessel filled with kerosene and clean them (rough cleaning).
 - ※ If dirty part is cleaned with kerosene just after putting it in vessel, it may be damaged. Leave it in kerosene for a while to loosen dust and dirty oil.
 - ※ If this kerosene is polluted, parts will be damaged and functions of reassembled valve will be degraded.
Therefore, control cleanliness of kerosene fully.
- ② Put parts in final cleaning vessel filled with kerosene, turning it slowly to clean them even to their insides (finish cleaning).
 - ※ Do not dry parts with compressed air, since they will be damaged and/or rusted by dust and moisture in air.

(16) Rust prevention of parts

- Apply rust-preventives to all parts.
- ※ If left as they are after being cleaned, they will be rusted and will not display their functions fully after being reassembled.

4) ASSEMBLY

- (1) Put shim (4), springs (5) and spring seat (6) onto spool (3) in this order.

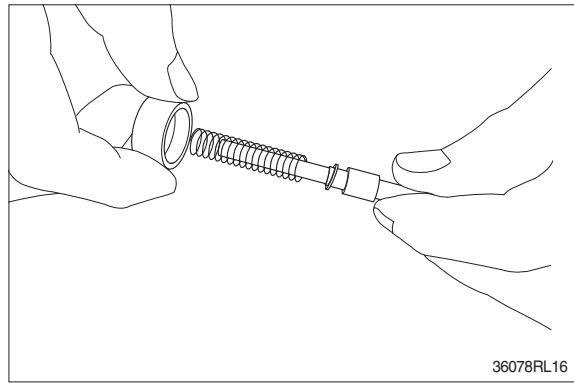

- (2) Assemble spring (7) into casing (1).
Assemble reducing valve subassembly into casing.
※ Assemble them to their original positions.

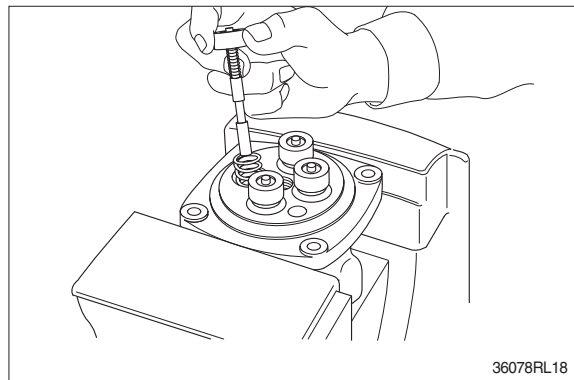

- (3) Assemble O-ring (10) onto plug (8).

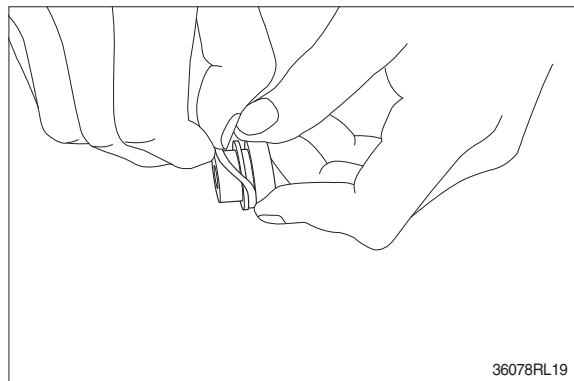

- (4) Assemble seal (11) to plug (8).
※ Assemble seal in such lip direction as shown below.

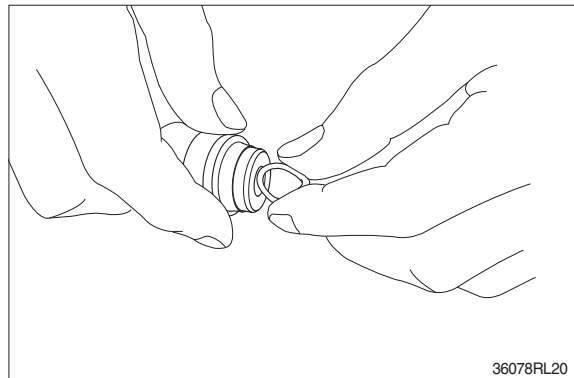

- (5) Assemble push rod (9) to plug (8).
※ Apply working oil on push-rod surface.

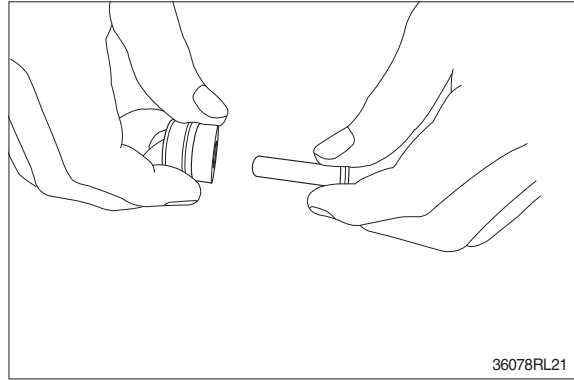

- (6) Assemble plug subassembly to casing.
※ When return spring is weak in force, subassembly stops due to resistance of O-ring.

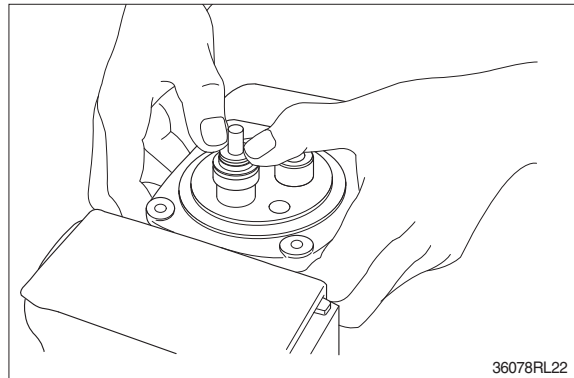

- (7) When return spring is strong in force, assemble 4 sets at the same time, utilizing plate (12), and tighten joint (15) temporarily.

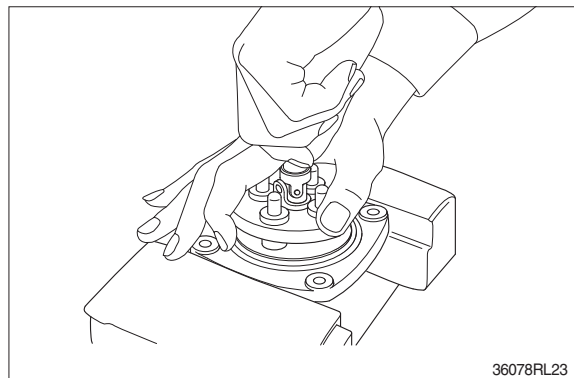

- (8) Fit plate (12).

- (9) Tighten joint (15) with the specified torque to casing, utilizing jig.

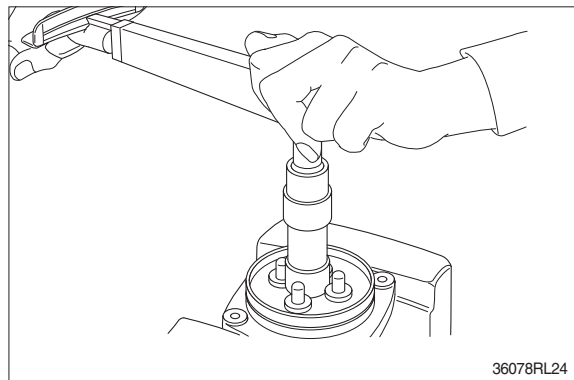

- (10) Assemble swash plate (16) to joint (15).
- ※ Screw it to position that it contacts with 4 push rods evenly.
 - ※ Do not screw it over.

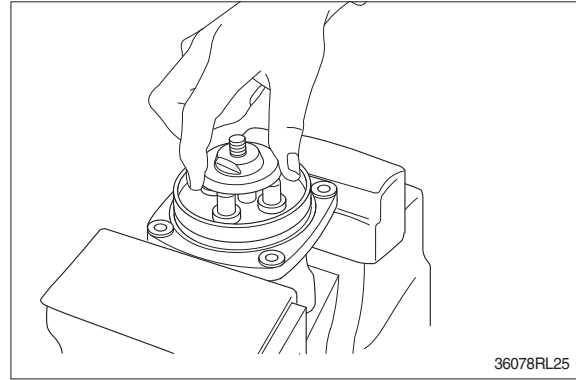

- (11) Assemble adjusting nut (17), apply spanner to width across flat of plate (16) to fix it, and tighten adjusting nut to the specified torque.
- ※ During tightening, do not change position of disk.

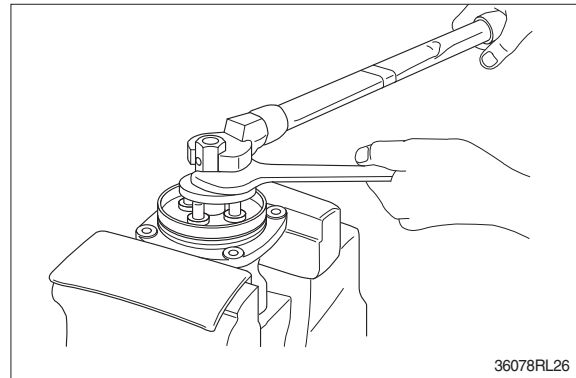

- (12) Fit boot (14) to plate.

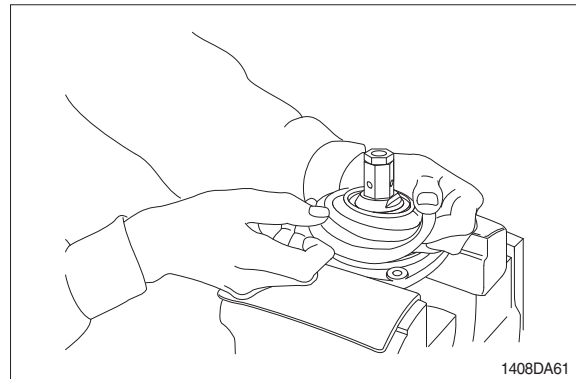

(13) Fit boot (23) and lock nut (22), and handle subassembly is assembled completely.

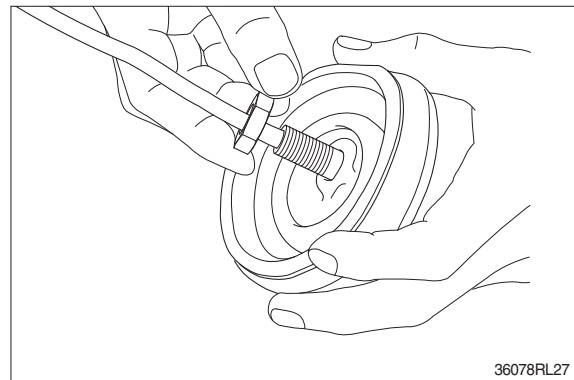
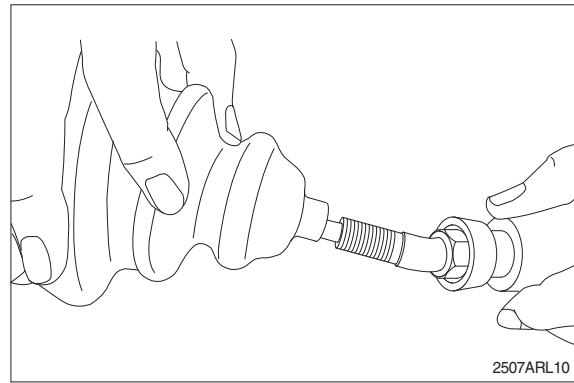

(14) Pull out cord and tube through adjusting nut hole provided in direction 60 ° to 120 ° from casing hole.

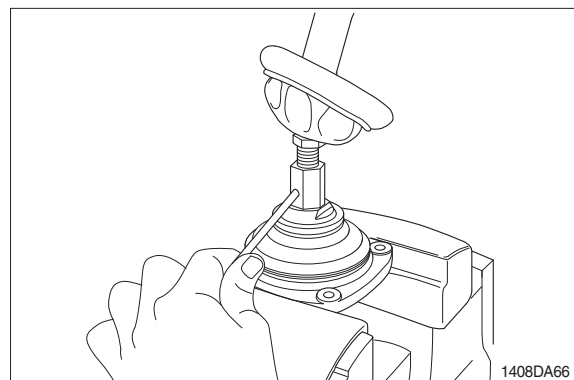

(15) Assemble bushing (18) to plate and pass cord and tube through it.
※ Provide margin necessary to operation.

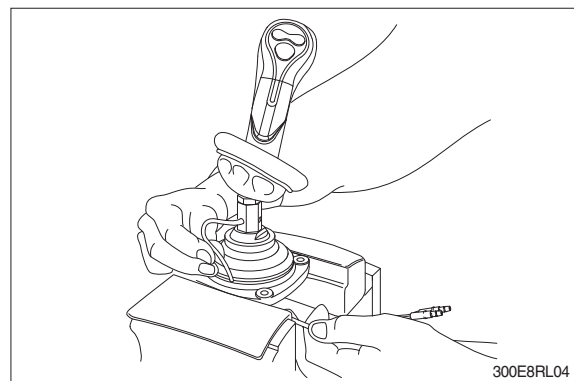

(16) Determine handle direction, tighten lock nut (22) to specified torque to fix handle.

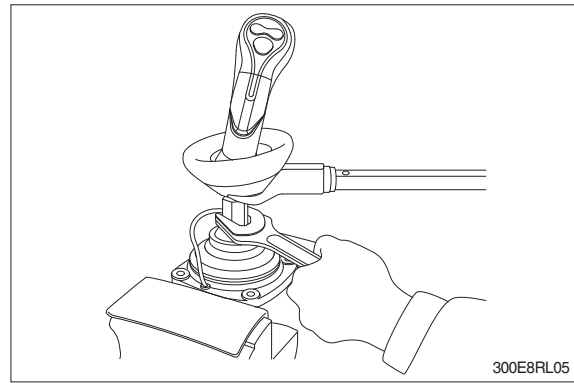

(17) Apply grease to rotating section of joint and contacting faces of disk and push rod.

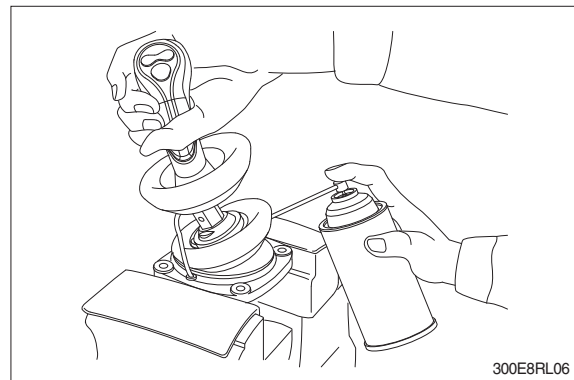

(18) Assemble lower end of bellows to casing.
(19) Inject volatile rust-preventives through all ports and then put blind plugs in ports.

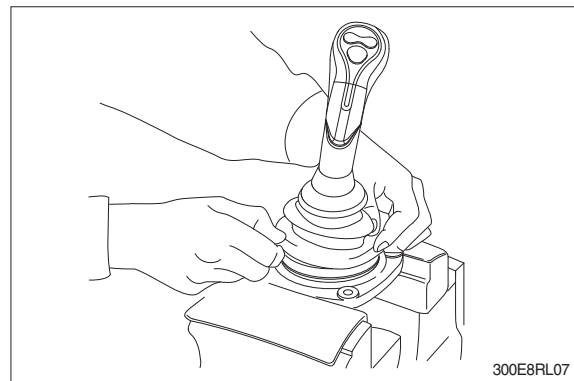

GROUP 8 TURNING JOINT

1. REMOVAL AND INSTALL

1) REMOVAL

- (1) Lower the work equipment to the ground and stop the engine.
- (2) Operate the control levers and pedals several times to release the remaining pressure in the hydraulic piping.
- (3) Loosen the breather slowly to release the pressure inside the hydraulic tank.

▲ **Escaping fluid under pressure can penetrate the skin causing serious injury.**

※ When pipes and hoses are disconnected, the oil inside the piping will flow out, so catch it in oil pan.

- (4) Disconnect all hoses.
- (5) Sling the turning joint assembly (1) and remove the mounting bolt (2).
 - Weight : 50 kg (110 lb)
 - Tightening torque : $12.3 \pm 1.3 \text{ kgf} \cdot \text{m}$
($88.9 \pm 9.4 \text{ lbf} \cdot \text{ft}$)
- (6) Remove the turning joint assembly.

※ When removing the turning joint, check that all the hoses have been disconnected.

2) INSTALL

- (1) Carry out installation in the reverse order to removal.
 - ※ Take care of turning joint direction.
 - ※ Assemble hoses to their original positions.Confirm the hydraulic oil level and check the hydraulic oil leak or not.

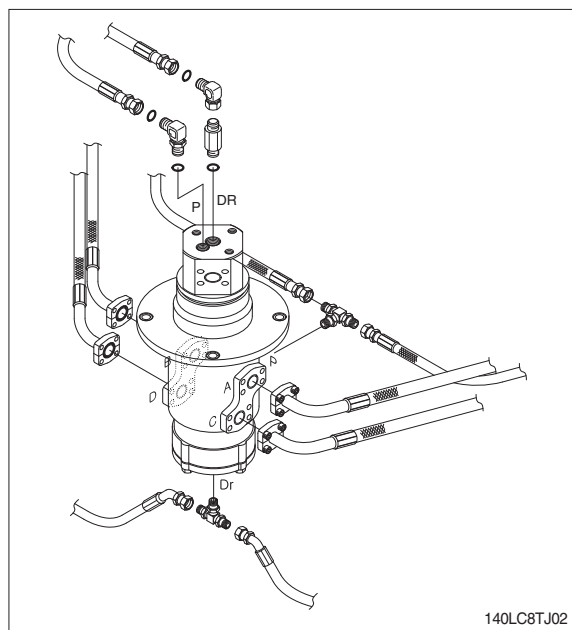
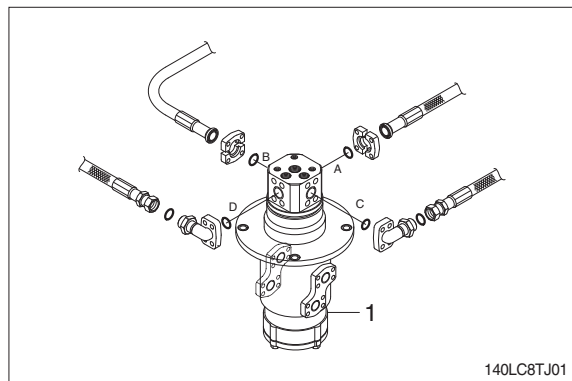

2. DISASSEMBLY AND ASSEMBLY

1) STRUCTURE

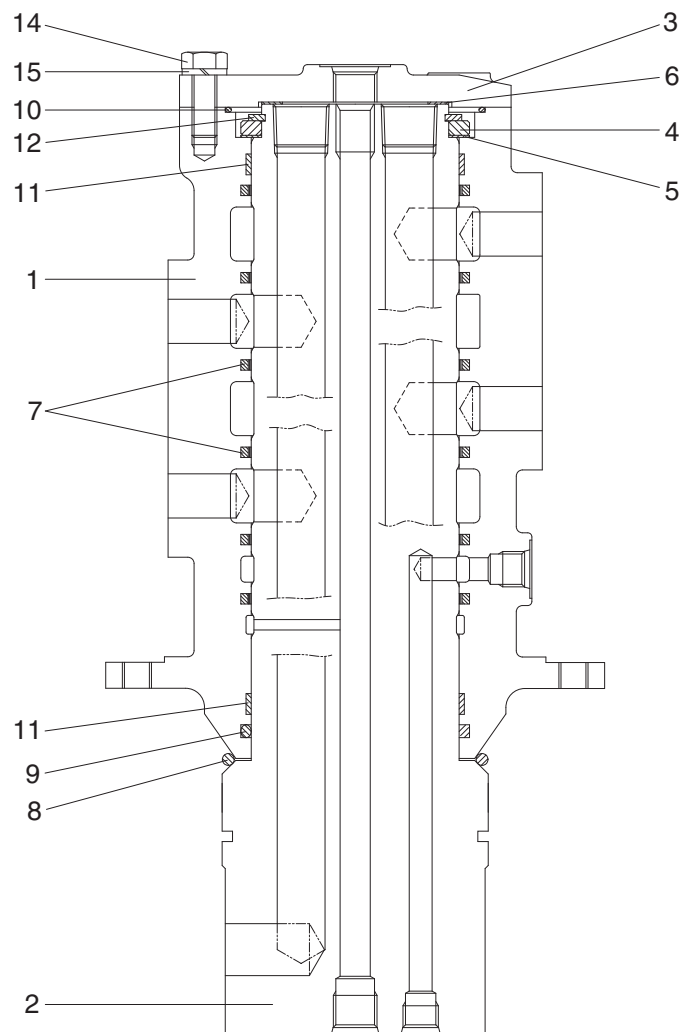

14098TJ03

- | | | | | | |
|---|--------|----|--------------|----|---------------|
| 1 | Hub | 6 | Shim | 11 | Wear ring |
| 2 | Shaft | 7 | Slipper seal | 12 | Retainer ring |
| 3 | Cover | 8 | O-ring | 13 | Plug |
| 4 | Spacer | 9 | O-ring | 14 | Hexagon bolt |
| 5 | Shim | 10 | O-ring | 15 | Spring washer |

2) DISASSEMBLY

※ Before the disassembly, clean the turning joint.

(1) Remove bolts (14), washer (15) and cover (3).

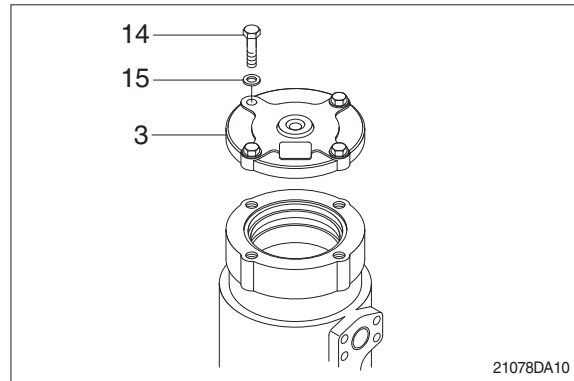

(2) Remove shim (6) and O-ring (10).

(3) Remove retainer ring (12), spacer (4) and shim (5).

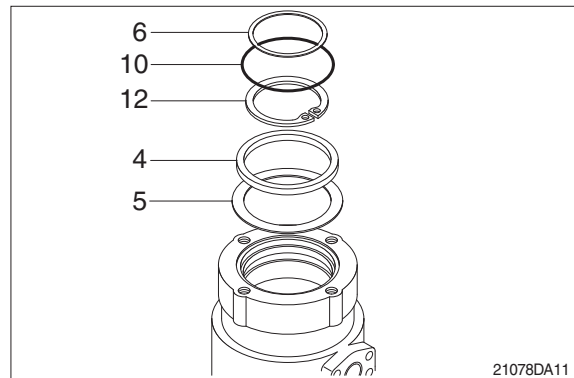

(4) Place hub (1) on a V-block and by using a wood buffer at the shaft end, hit out shaft (2) to about 1/2 from the body with a hammer.

※ Take care not to damage the shaft (2) when remove hub (1) or rest it sideways.

※ Put a fitting mark on hub (1) and shaft (2).

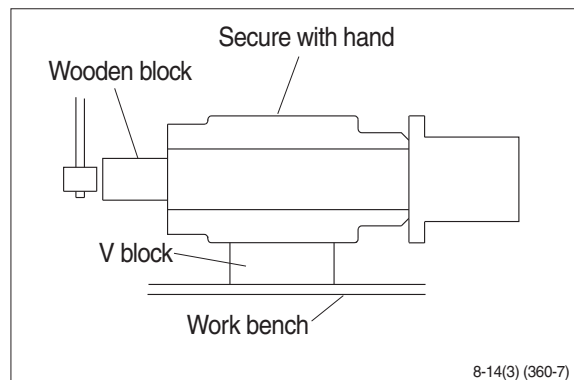

(5) Remove six slipper seals (7) and O-ring (9), two wear ring (11) from hub (1).

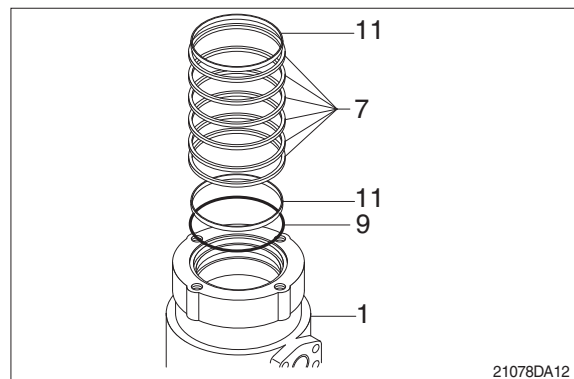

3) ASSEMBLY

- ※ Clean all parts.
- ※ As a general rule, replace oil seals and O-ring.
- ※ Coat the sliding surfaces of all parts with engine oil or grease before installing.

(1) Fix seven slipper seal (7) and O-ring (9), two wear ring (11) to hub (1).

(2) Fit O-ring (8) to shaft (2).

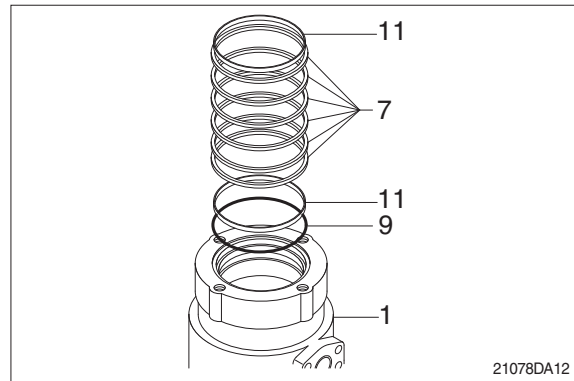

(3) Set shaft (2) on block, tap hub (1) with a plastic hammer to install.

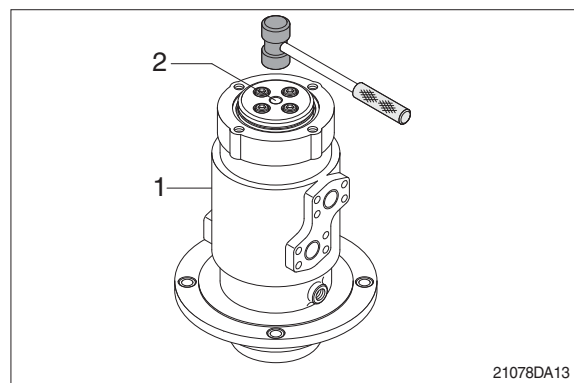

(4) Fit shim (5), spacer (4) and retainer ring (12) to shaft (2).

(5) Fit O-ring (10) to hub (1).

(6) Fit shim (6) to shaft (2).

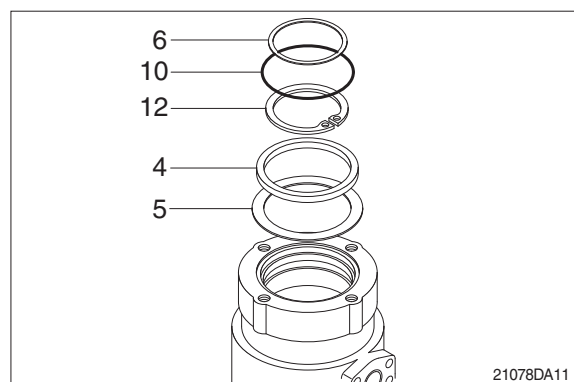

- (7) Install cover (3) to body (1) and tighten bolts (14).
- Torque : 10~12.5 kgf · m
(72.3~90.4 lbf · ft)

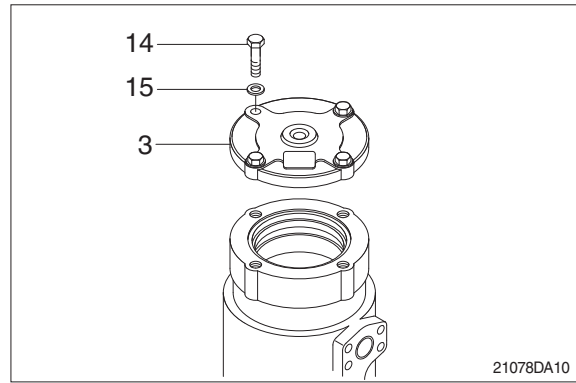

GROUP 9 BOOM, ARM, BUCKET AND DOZER CYLINDERS

1. REMOVAL AND INSTALL

1) BUCKET CYLINDER

(1) Removal

- ※ Expand the arm and bucket fully, lower the work equipment to the ground and stop the engine.
- ※ Operate the control levers and pedals several times to release the remaining pressure in the hydraulic piping.
- ※ Loosen the breather slowly to release the pressure inside the hydraulic tank.
- ▲ **Escaping fluid under pressure can penetrate the skin causing serious injury.**
- ※ Fit blind plugs in the hoses after disconnecting them, to prevent dirt or dust from entering.

- ① Set block between bucket cylinder and arm.

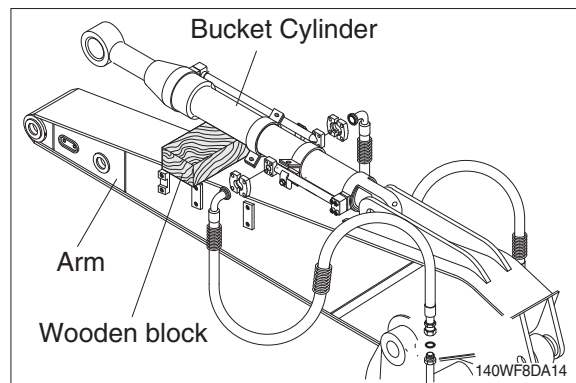

- ② Remove bolt (2), nut (3) and pull out pin (1).

· Tightening torque : 29.7 ± 4.5 kgf-m
(215 ± 32.5 lbf-ft)

- ※ Tie the rod with wire to prevent it from coming out.

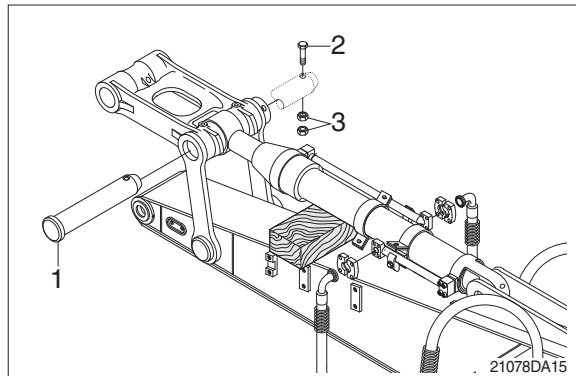

- ③ Disconnect bucket cylinder hoses (4) and put plugs (5) on cylinder pipe.

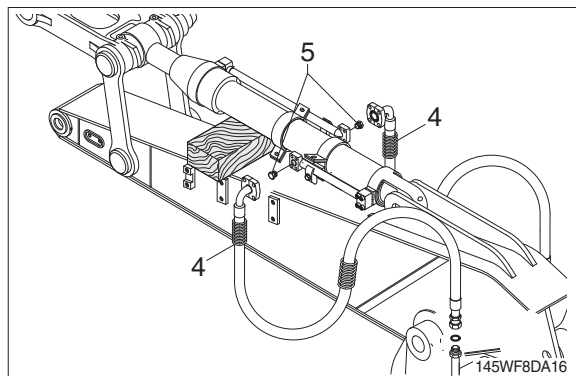

- ④ Sling bucket cylinder assembly (8) and remove bolt (6) then pull out pin (5).
- ⑤ Remove bucket cylinder assembly (8).
 - Weight : 100 kg (220 lb)
 - Tightening torque : 29.7 ± 4.5 kgf-m
(215 ± 32.5 lbf-ft)

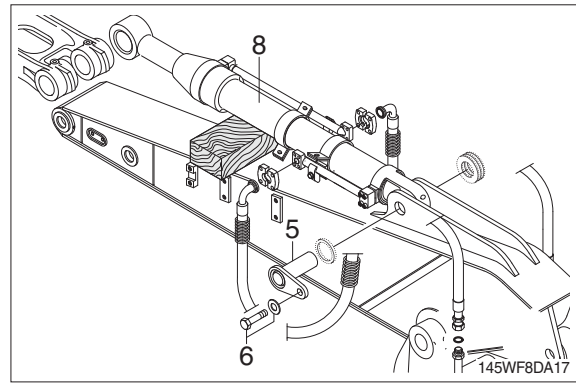

(2) Install

- ① Carry out installation in the reverse order to removal.
- ▲ When aligning the mounting position of the pin, do not insert your fingers in the pin hole.**
- ※ Bleed the air from the bucket cylinder.
 - ※ Confirm the hydraulic oil level and check the hydraulic oil leak or not.

2) ARM CYLINDER

(1) Removal

- ※ Expand the arm and bucket fully, lower the work equipment to the ground and stop the engine.
- ※ Operate the control levers and pedals several times to release the remaining pressure in the hydraulic piping.
- ※ Loosen the breather slowly to release the pressure inside the hydraulic tank.

▲ Escaping fluid under pressure can penetrate the skin causing serious injury. Fit blind plugs in the hoses after disconnecting them, to prevent dirt or dust from entering.

- ① Set block between arm cylinder and boom.

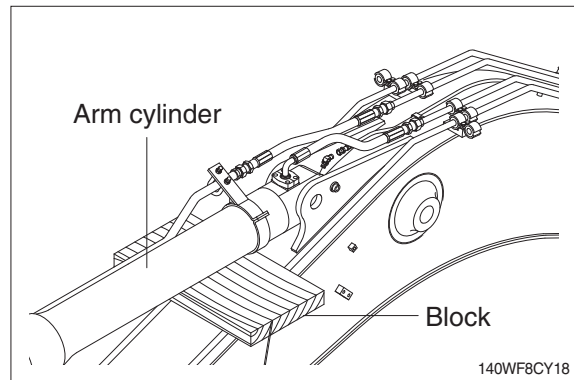

- ② Remove bolt (2) and pull out pin (1).

- ※ Tie the rod with wire to prevent it from coming out.
 - Tightening torque : 29.7 ± 4.5 kgf·m
(215 ± 32.5 lbf·ft)

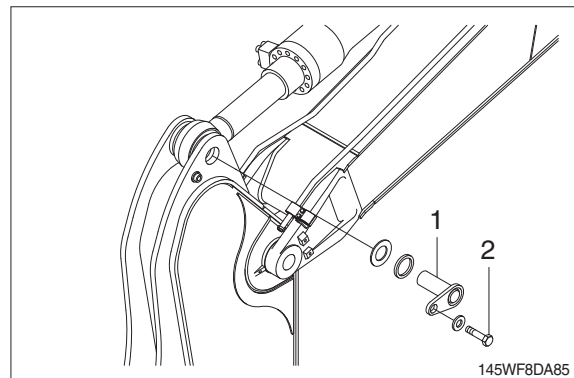

- ③ Disconnect arm cylinder hoses (4) and put plugs on cylinder pipe.

- ④ Disconnect greasing pipings (5).

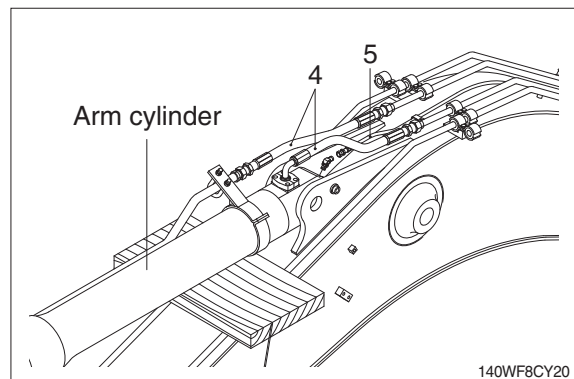

- ⑤ Sling arm cylinder assembly(8) and remove bolt (7) then pull out pin (6).
- ⑥ Remove arm cylinder assembly (8).
 - Weight : 160 kg (350 lb)
 - Tightening torque : 29.7 ± 4.5 kgf-m
(215 ± 32.5 lbf-ft)

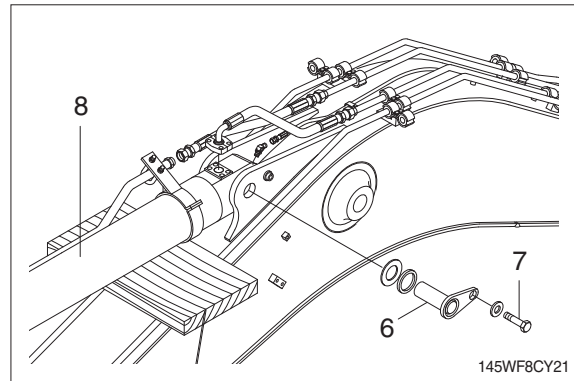

(2) Install

- ① Carry out installation in the reverse order to removal.
- ▲ When aligning the mounting position of the pin, do not insert your fingers in the pin hole.**
- ※ Bleed the air from the arm cylinder.
 - ※ Confirm the hydraulic oil level and check the hydraulic oil leak or not.

3) BOOM CYLINDER

(1) Removal

- ※ Expand the arm and bucket fully, lower the work equipment to the ground and stop the engine.
- ※ Operate the control levers and pedals several times to release the remaining pressure in the hydraulic piping.
- ※ Loosen the breather slowly to release the pressure inside the hydraulic tank.

▲ Escaping fluid under pressure can penetrate the skin causing serious injury.

- ※ Fit blind plugs in the hoses after disconnecting them, to prevent dirt or dust from entering.
- ① Disconnect greasing hoses (1).
 - ② Sling boom cylinder assembly.

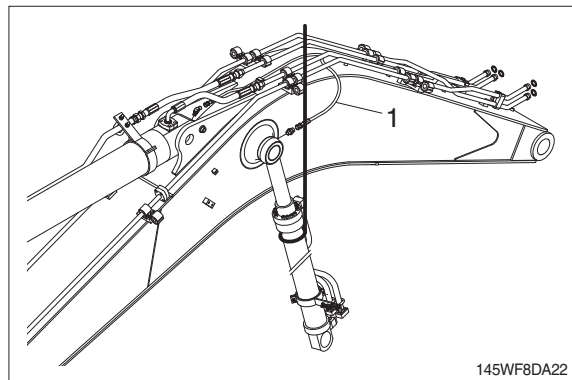

- ③ Remove bolt (4), stopper (5) and pull out pin (2).

· Tightening torque : 29.7 ± 4.5 kgf·m
(215 ± 32.5 lbf·ft)

- ※ Tie the rod with wire to prevent it from coming out.

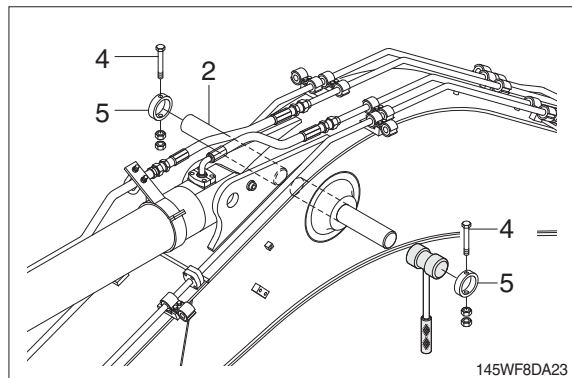

- ④ Lower the boom cylinder assembly (6) on a stand.

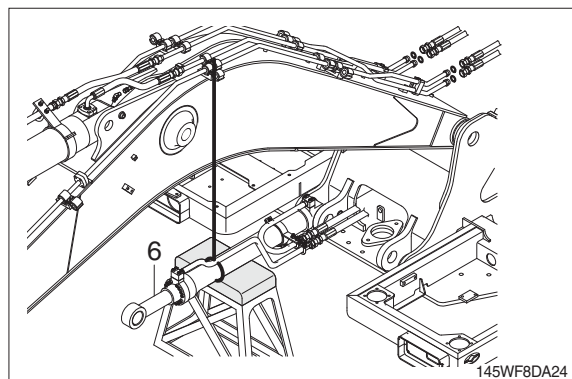

- ⑤ Disconnect boom cylinder hoses (7) and put plugs on cylinder pipe.

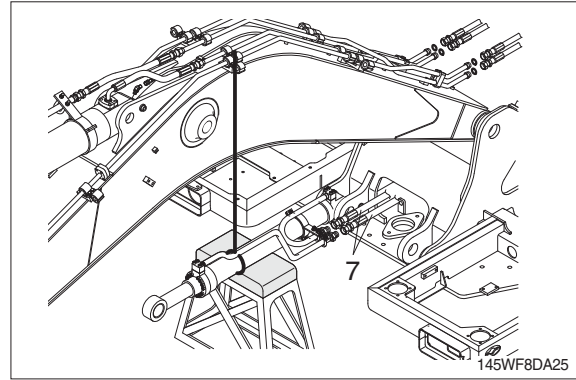

- ⑥ Remove bolt (9) and pull out pin (8).
· Tightening torque : 29.7 ± 4.5 kgf-m
(215 ± 32.5 lbf-ft)
- ⑦ Remove boom cylinder assembly (6).
· Weight : 130 kg (285 lb)

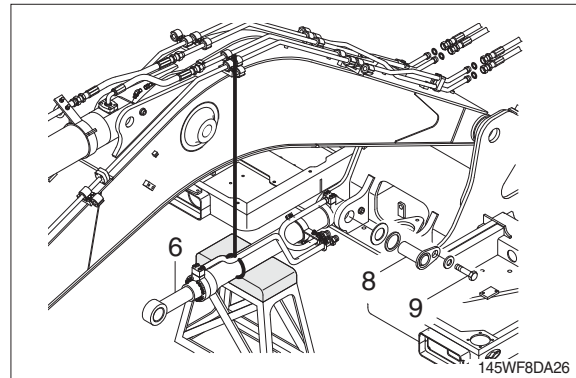

(2) Install

- ① Carry out installation in the reverse order to removal.
- ▲ **When aligning the mounting position of the pin, do not insert your fingers in the pin hole.**
- ※ Bleed the air from the boom cylinder.
 - ※ Confirmed the hydraulic oil level and check the hydraulic oil leak or not.

2. DISASSEMBLY AND ASSEMBLY

1) STRUCTURE

(1) Bucket cylinder

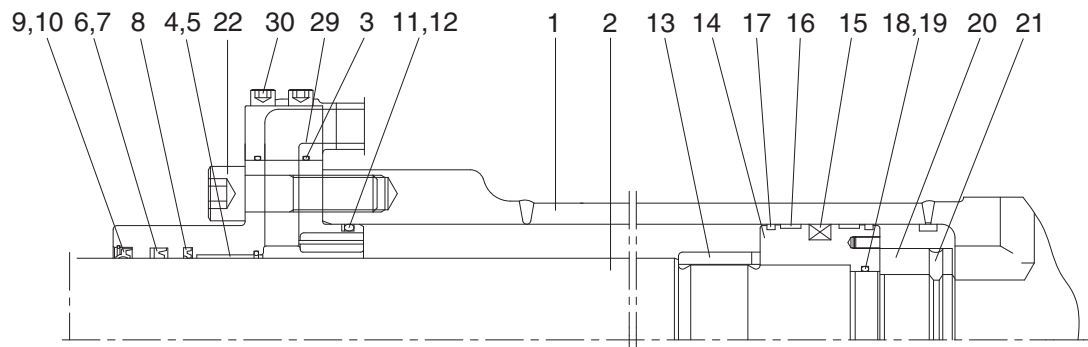

Internal detail

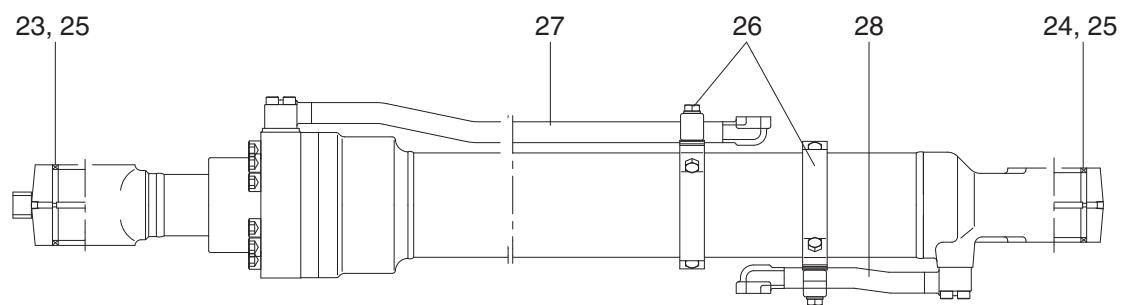

145WF8CY01

1	Tube assembly	11	O-ring	21	Hexagon socket set screw
2	Rod assembly	12	Back up ring	22	Hexagon socket head bolt
3	Gland	13	Cushion ring	23	Pin bushing
4	DD2 bushing	14	Piston	24	Pin bushing
5	Snap ring	15	Piston seal	25	Dust seal
6	Rod seal	16	Wear ring	26	Band assembly
7	Back up ring	17	Dust ring	27	Pipe assembly-R
8	Buffer ring	18	O-ring	28	Pipe assembly-B
9	Dust wiper	19	Back up ring	29	O-ring
10	Snap ring	20	Lock nut	30	Hexagon socket head bolt

(2) Arm cylinder

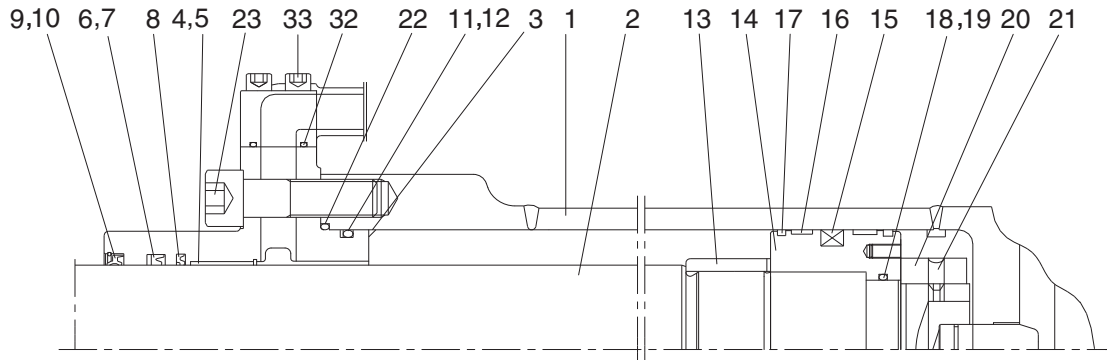

Internal detail

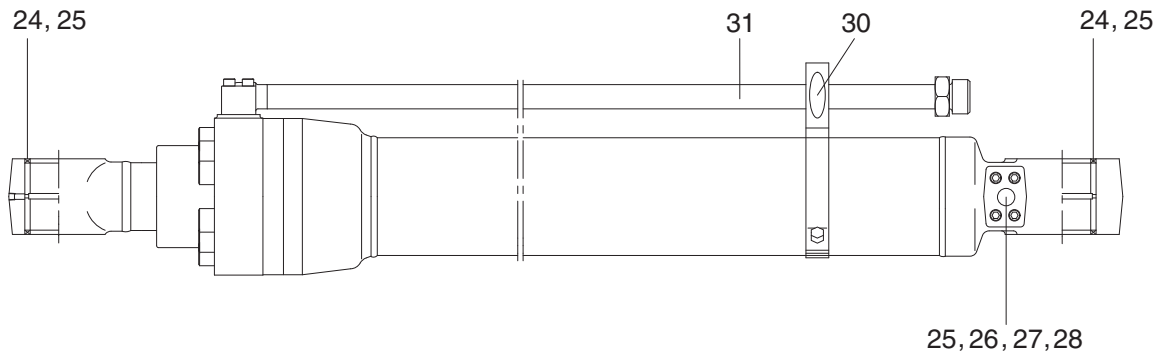

145WF8CY02

- | | | | | | |
|----|---------------|----|--------------------------|----|--------------------------|
| 1 | Tube assembly | 12 | Back up ring | 23 | Hexagon socket head bolt |
| 2 | Rod assembly | 13 | Cushion ring | 24 | Pin bushing |
| 3 | Gland | 14 | Piston | 25 | Dust seal |
| 4 | DD2 bushing | 15 | Piston seal | 26 | Check valve |
| 5 | Snap ring | 16 | Wear ring | 27 | Coil spring |
| 6 | Rod seal | 17 | Dust ring | 28 | O-ring |
| 7 | Back up ring | 18 | O-ring | 29 | Plug |
| 8 | Buffer ring | 19 | Back up ring | 30 | Band assembly |
| 9 | Dust wiper | 20 | Lock nut | 31 | Pipe assembly-R |
| 10 | Snap ring | 21 | Hexagon socket set screw | 32 | O-ring |
| 11 | O-ring | 22 | O-ring | 33 | Hexagon socket head bolt |

(3) Boom cylinder

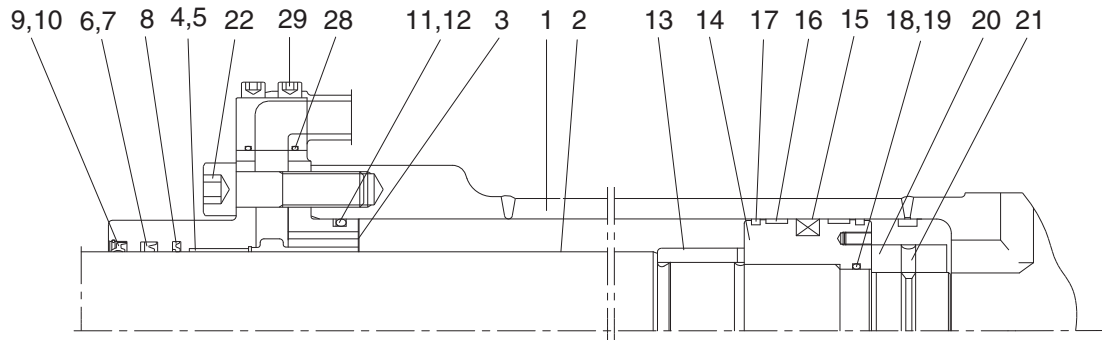

Internal detail

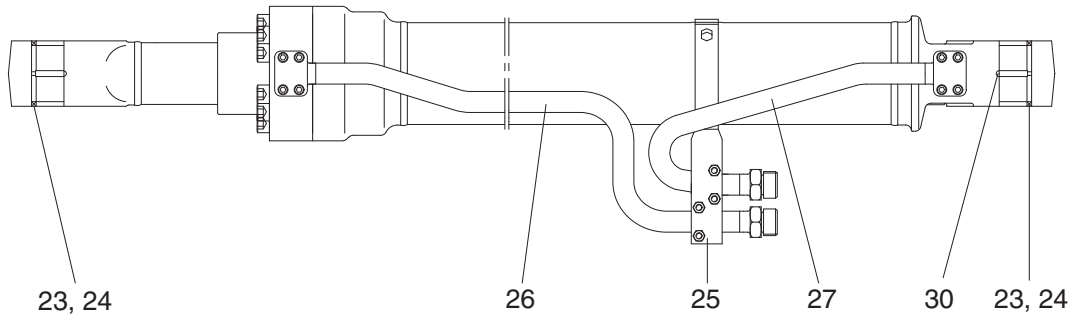

140LC8CY03

- | | | | | | |
|----|---------------|----|--------------|----|--------------------------|
| 1 | Tube assembly | 11 | O-ring | 21 | Hexagon socket set screw |
| 2 | Rod assembly | 12 | Back up ring | 22 | Hexagon socket head bolt |
| 3 | Gland | 13 | Cushion ring | 23 | Pin bushing |
| 4 | DD2 bushing | 14 | Piston | 24 | Dust seal |
| 5 | Snap ring | 15 | Piston seal | 25 | Band assembly |
| 6 | Rod seal | 16 | Wear ring | 26 | Pipe assembly-R |
| 7 | Back up ring | 17 | Dust ring | 27 | Pipe assembly-B |
| 8 | Buffer ring | 18 | O-ring | 28 | O-ring |
| 9 | Dust wiper | 19 | Back up ring | 29 | Hexagon socket head bolt |
| 10 | Snap ring | 20 | Lock nut | 30 | Socket plug |

(4) Adjust boom cylinder

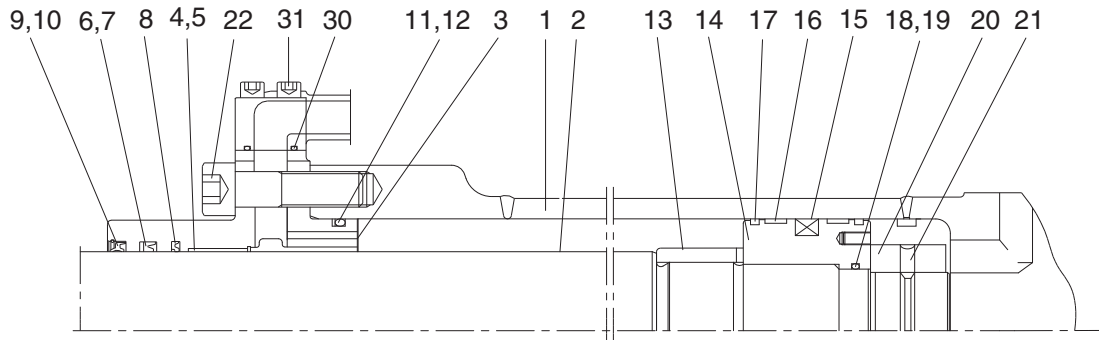

Internal detail

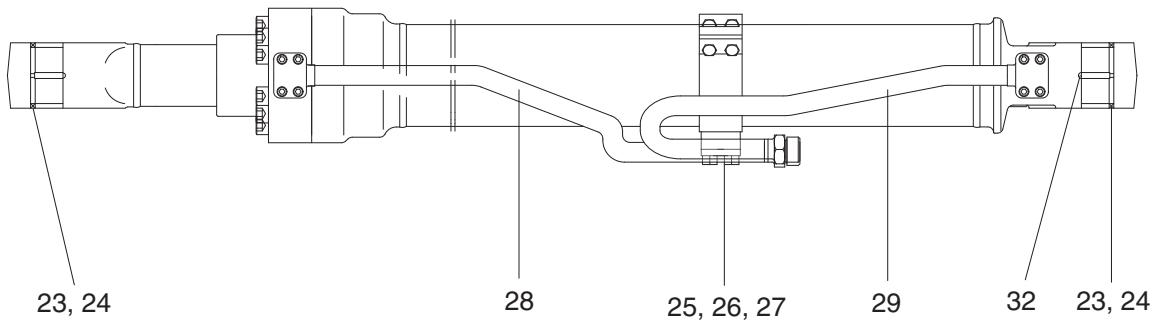

140LC8CY04

- | | | | | | |
|----|---------------|----|--------------------------|----|--------------------------|
| 1 | Tube assembly | 12 | Back up ring | 23 | Pin bushing |
| 2 | Rod assembly | 13 | Cushion ring | 24 | Dust seal |
| 3 | Gland | 14 | Piston | 25 | Band assembly |
| 4 | DD2 bushing | 15 | Piston seal | 26 | Hexagon head bolt |
| 5 | Snap ring | 16 | Wear ring | 27 | Spring washer |
| 6 | Rod seal | 17 | Dust ring | 28 | Pipe assembly-R |
| 7 | Back up ring | 18 | O-ring | 29 | Pipe assembly-B |
| 8 | Buffer ring | 19 | Back up ring | 30 | O-ring |
| 9 | Dust wiper | 20 | Lock nut | 31 | Hexagon socket head bolt |
| 10 | Snap ring | 21 | Hexagon socket set screw | 32 | Socket plug |
| 11 | O-ring | 22 | Hexagon socket head bolt | | |

(5) Dozer cylinder

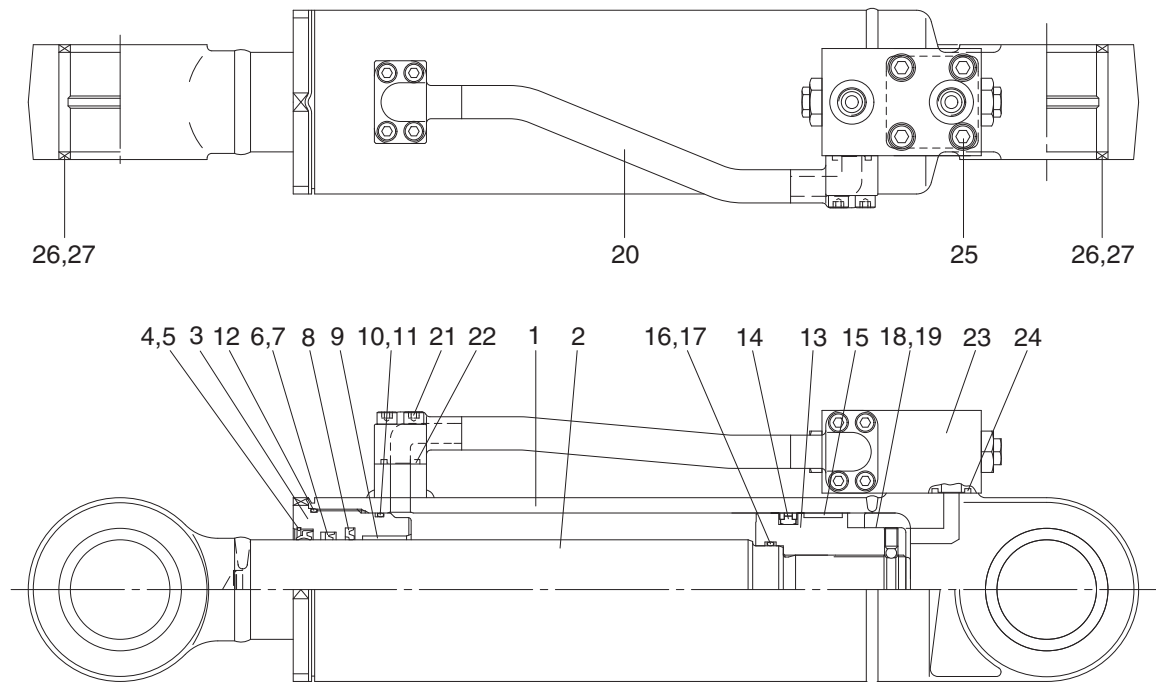

14098CY05

- | | | | | | |
|---|---------------|----|--------------|----|--------------------------|
| 1 | Tube assembly | 10 | O-ring | 19 | Set screw |
| 2 | Rod assembly | 11 | Back up ring | 20 | Pipe assembly |
| 3 | Gland | 12 | O-ring | 21 | Hexagon socket head bolt |
| 4 | Dust wiper | 13 | Piston | 22 | O-ring |
| 5 | Retainer ring | 14 | Piston seal | 23 | Check valve assembly |
| 6 | Rod seal | 15 | Wear ring | 24 | O-ring |
| 7 | Back up ring | 16 | O-ring | 25 | Hexagon socket head bolt |
| 8 | Buffer ring | 17 | Back up ring | 26 | Pin bushing |
| 9 | DU bushing | 18 | Steel ball | 27 | Dust seal |

2) TOOLS AND TIGHTENING TORQUE

(1) Tools

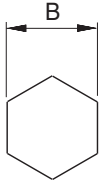
Tool name	Remark	
Allen wrench	6	
	8	
	14	
	17	
Spanner	7	
	8	
(-) Driver	Small and large sizes	
Torque wrench	Capable of tightening with the specified torques	

(2) Tightening torque

Part name	Item	Size	Torque		
			kgf · m	lbf · ft	
Socket head bolt	Bucket cylinder (★1)	22	M14	15 ± 2.0	108 ± 14.5
	Boom cylinder (★1)	22	M14	15 ± 2.0	108 ± 14.5
	Arm cylinder (★1)	23	M16	23 ± 2.0	166 ± 14.5
	Adjust boom cylinder (★1)	22	M14	15 ± 2.0	108 ± 14.5
Check valve mounting socket head bolt	Dozer cylinder	25	M10	5.4 ± 0.5	39.1 ± 3.6
Pipe mounting socket head bolt	Bucket cylinder	30	M10	5.4 ± 0.5	39.1 ± 3.6
	Boom cylinder	29	M8	2.7 ± 0.3	19.5 ± 2.2
	Arm cylinder	33	M10	5.4 ± 0.5	39.1 ± 3.6
	Adjust boom cylinder	29	M8	2.7 ± 0.3	19.5 ± 2.2
	Dozer cylinder	21	M8	2.7 ± 0.3	19.5 ± 2.2
Lock nut	Bucket cylinder	20	M45	100 ± 10.0	723 ± 72.3
	Boom cylinder	20	M50		
	Arm cylinder	20	M55		
	Adjust boom cylinder	20	M50		
Piston	Bucket cylinder	14	-	150 ± 15.0	1085 ± 109
	Boom cylinder	14			
	Arm cylinder	14			
	Adjust boom cylinder	14			
	Dozer cylinder	13			
Gland	Dozer cylinder	3	M105	85 ± 8.5	615 ± 61.5
Set screw	Bucket cylinder	21	M8	2.7 ± 0.3	19.5 ± 2.2
	Boom cylinder	21	M8	2.7 ± 0.3	19.5 ± 2.2
	Arm cylinder	21	M8	2.7 ± 0.3	19.5 ± 2.2
	Adjust boom cylinder	21	M8	2.7 ± 0.3	19.5 ± 2.2
	Dozer cylinder	19	M8	2.7 ± 0.3	19.5 ± 2.2

※ Apply loctite #243 (★1) on the thread before tightening.

3) DISASSEMBLY

(1) Remove cylinder head and piston rod

※ Procedures are based on the bucket cylinder.

① Hold the clevis section of the tube in a vise.

※ Use mouth pieces so as not to damage the machined surface of the cylinder tube. Do not make use of the outside piping as a locking means.

② Pull out rod assembly (2) about 200mm (7.1in). Because the rod assembly is rather heavy, finish extending it with air pressure after the oil draining operation.

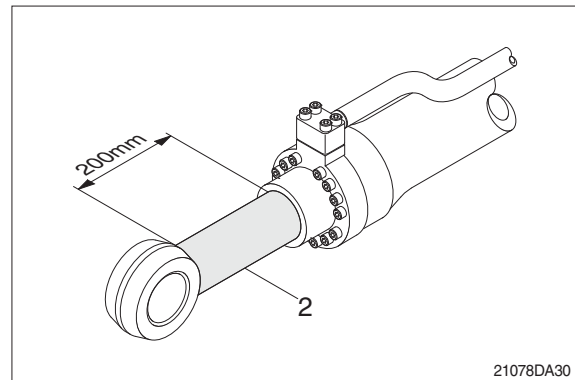

③ Loosen and remove socket bolts (22) of the gland in sequence.

※ Cover the extracted rod assembly (2) with rag to prevent it from being accidentally damaged during operation.

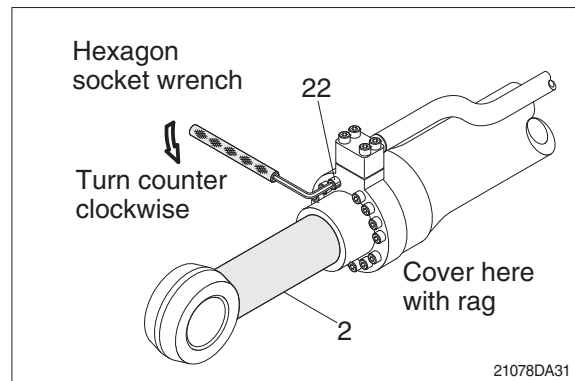

④ Draw out cylinder head and rod assembly together from tube assembly (1).

※ Since the rod assembly is heavy in this case, lift the tip of the rod assembly (2) with a crane or some means and draw it out. However, when rod assembly (2) has been drawn out to approximately two thirds of its length, lift it in its center to draw it completely.

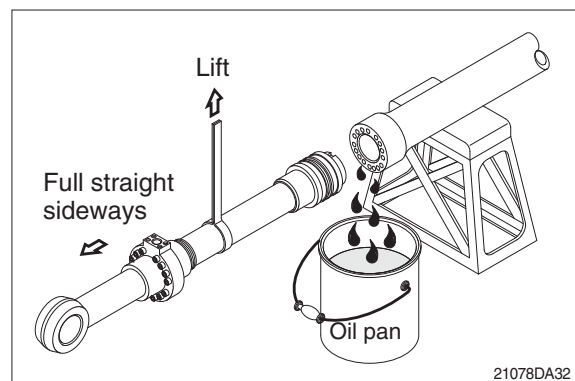

Note that the plated surface of rod assembly (2) is to be lifted. For this reason, do not use a wire sling and others that may damage it, but use a strong cloth belt or a rope.

- ⑤ Place the removed rod assembly on a wooden V-block that is set level.
- ※ Cover a V-block with soft rag.

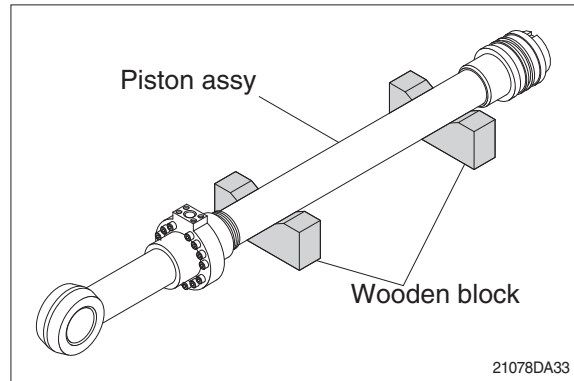

(2) Remove piston and cylinder head

- ① Remove set screw (21).
- ※ Since set screw (21) and lock nut (20) is tightened to a high torque, use a hydraulic and power wrench that utilizes a hydraulic cylinder, to remove the lock set screw (21) and lock nut (20).
- ② Remove piston assembly (14), back up ring (19), and O-ring (18).

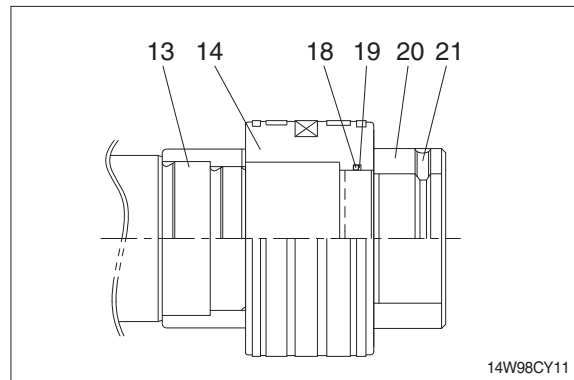

- ③ Remove the cylinder head assembly from rod assembly (2).
 - ※ If it is too heavy to move, move it by striking the flanged part of cylinder head with a plastic hammer.
 - ※ Pull it straight with cylinder head assembly lifted with a crane.
- Exercise care so as not to damage the lip of rod bushing (4) and packing (5,6,7,8,9,10) by the threads of rod assembly (2).

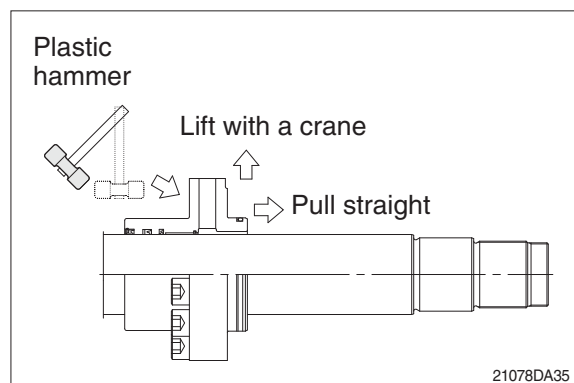

(3) Disassemble the piston assembly

- ① Remove wear ring (16).
 - ② Remove dust ring (17) and piston seal (15).
- ※ Exercise care in this operation not to damage the grooves.

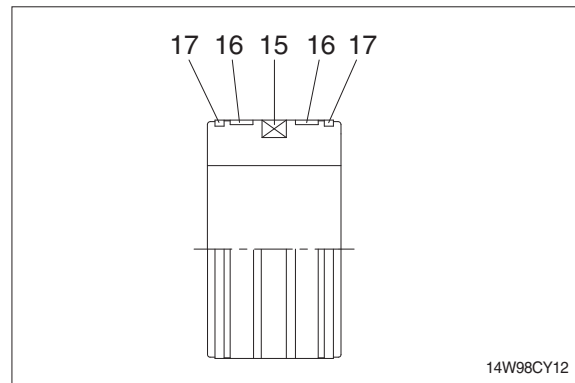

(4) Disassemble cylinder head assembly

- ① Remove back up ring (12) and O-ring (11).
 - ② Remove snap ring (10), dust wiper (9).
 - ③ Remove back up ring (7), rod seal (6) and buffer ring (8).
- ※ Exercise care in this operation not to damage the grooves.
- ※ Do not remove seal and ring, if does not damaged.
- ※ Do not remove bushing (4).

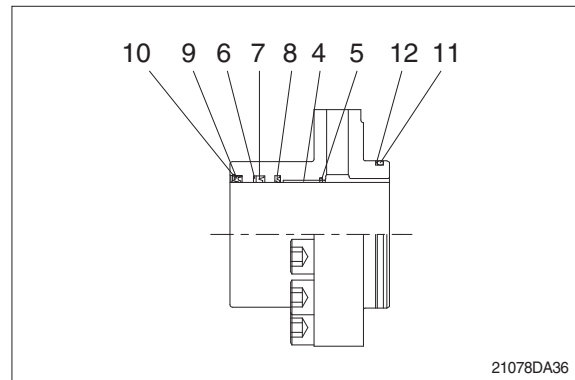

3) ASSEMBLY

(1) Assemble cylinder head assembly

※ Check for scratches or rough surfaces if found smooth with an oil stone.

① Coat the inner face of gland (3) with hydraulic oil.

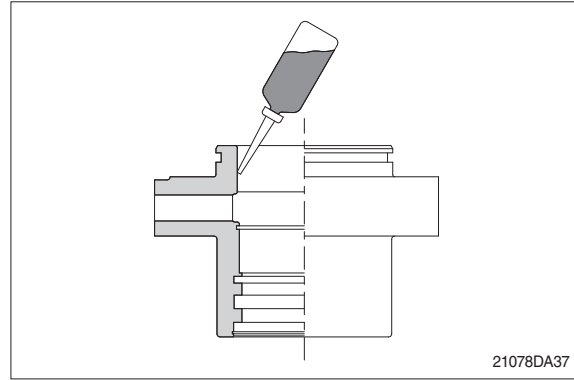

② Coat dust wiper (9) with grease and fit dust wiper (9) to the bottom of the hole of dust seal.

At this time, press a pad metal to the metal ring of dust seal.

③ Fit snap ring (10) to the stop face.

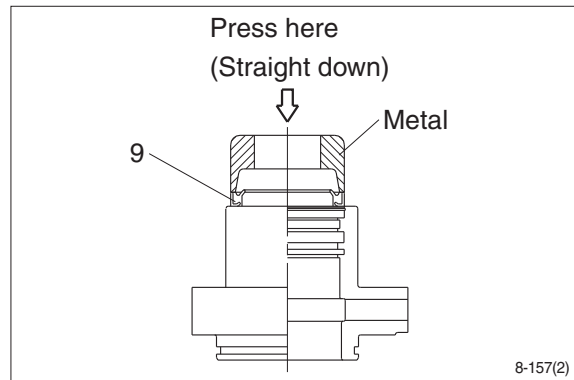

④ Fit back up ring (7), rod seal (6) and buffer ring (8) to corresponding grooves, in that order.

※ Coat each packing with hydraulic oil before fitting it.

※ Insert the backup ring until one side of it is inserted into groove.

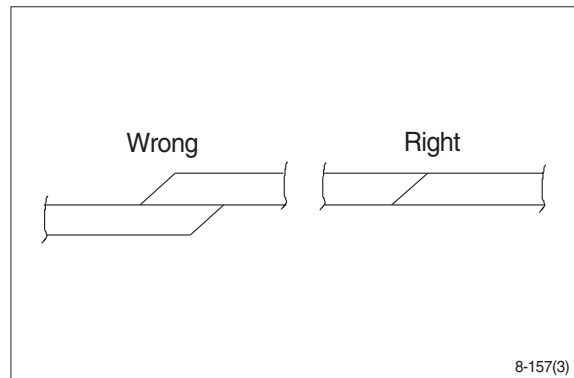

※ Rod seal (6) has its own fitting direction. Therefore, confirm it before fitting them.

※ Fitting rod seal (6) upside down may damage its lip. Therefore check the correct direction that is shown in fig.

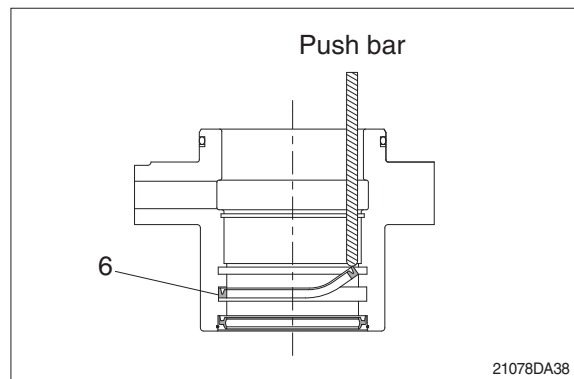

- ⑤ Fit back up ring (12) to gland (3).
- ※ Put the backup ring in the warm water of 30~50°C.
- ⑥ Fit O-ring (11) to gland (3).

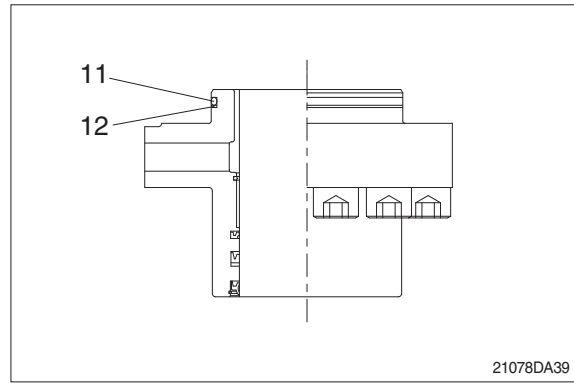

(2) Assemble piston assembly

- ※ Check for scratches or rough surfaces. If found smooth with an oil stone.
- ① Coat the outer face of piston (14) with hydraulic oil.

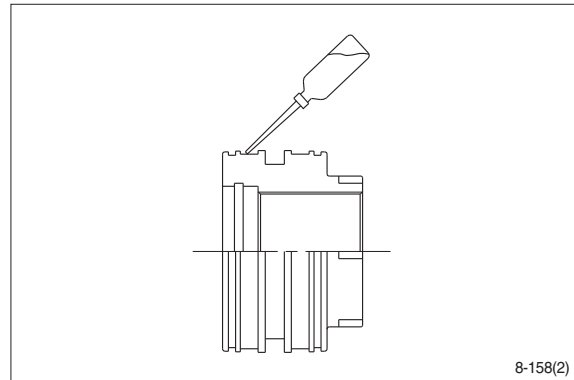

- ② Fit piston seal (15) to piston.
- ※ Put the piston seal in the warm water of 60~100°C for more than 5 minutes.
- ※ After assembling the piston seal, press its outer diameter to fit in.

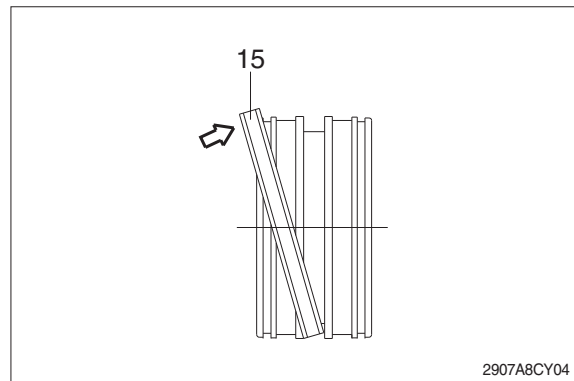

- ③ Fit wear ring (16) and dust ring (17) to piston (14).

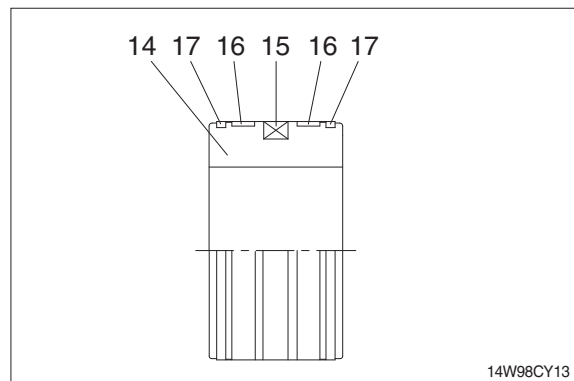

(3) Install piston and cylinder head

- ① Fix the rod assembly to the work bench.
- ② Apply hydraulic oil to the outer surface of rod assembly (2), the inner surface of piston and cylinder head.
- ③ Insert cylinder head assembly to rod assembly.

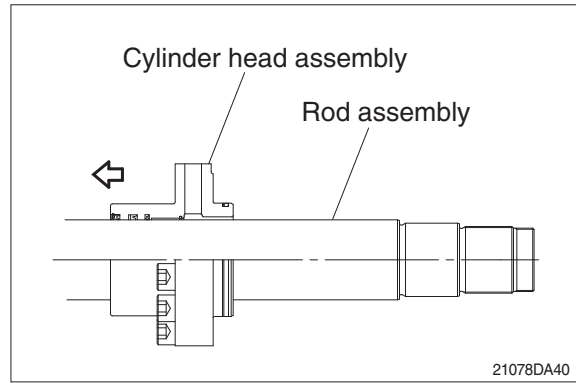

- ④ Insert cushion ring (13) to rod assembly.
- ※ Note that cushion ring (13) has a direction in which it should be fitted.

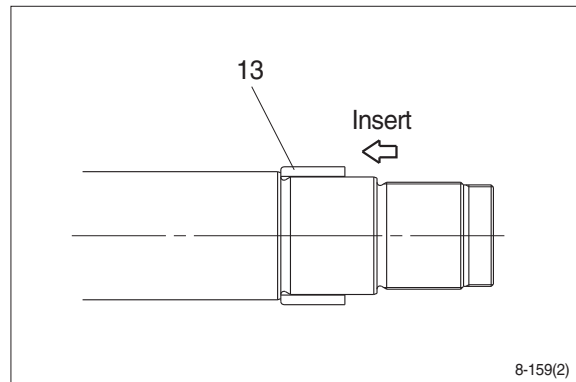

- ⑤ Fit piston assembly to rod assembly.
- Tightening torque : $150 \pm 15 \text{ kgf} \cdot \text{m}$
($1085 \pm 108 \text{ lbf} \cdot \text{ft}$)

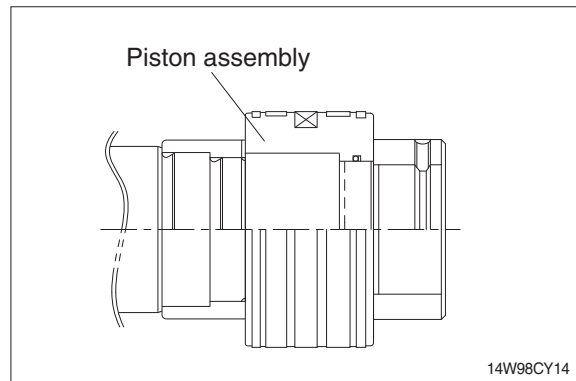

- ⑥ Fit lock nut (20) and tighten the set screw (21).
- Tightening torque :

Item		kgf · m	lbf · ft
20	Bucket	100 ± 10	723 ± 72.3
	Boom		
	Arm		
21		2.7 ± 0.3	19.5 ± 2.2

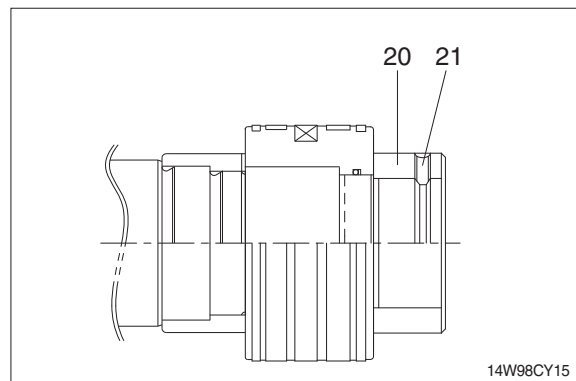

(3) Overall assemble

- ① Place a V-block on a rigid work bench.
Mount the tube assembly (1) on it and fix the assembly by passing a bar through the clevis pin hole to lock the assembly.
- ② Insert the rod assembly in to the tube assembly, while lifting and moving the rod assembly with a crane.
 - ※ Be careful not to damage piston seal by thread of tube assembly.
- ③ Match the bolt holes in the cylinder head flange to the tapped holes in the tube assembly and tighten socket bolts to a specified torque.
 - ※ Refer to the table of tightening torque.

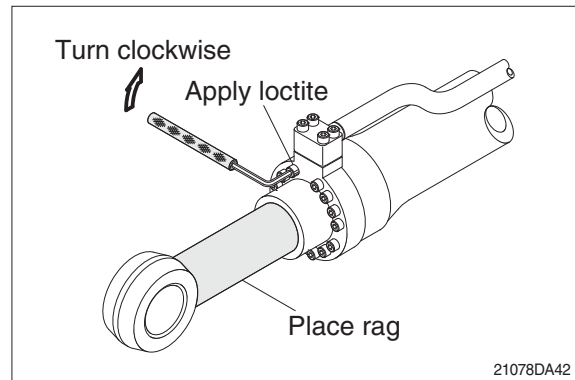
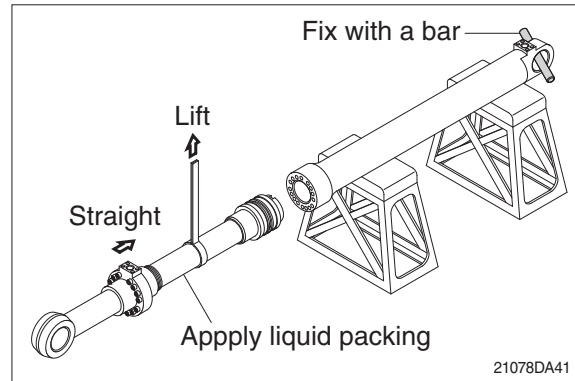

GROUP 10 UNDERCARRIAGE

1. TRACK LINK

1) REMOVAL

(1) Move track link until master pin is over front idler in the position put wooden block as shown.

(2) Loosen tension of the track link.

※ If track tension is not relieved when the grease valve is loosened, move the machine backwards and forwards.

※ Unscrew the grease nipple after release the tension by pushing the poppet only when necessarily required.

Grease leaking hole is not existing. So, while unscrew the grease nipple, grease is not leaking until the grease nipple is completely coming out. If the tension is not released in advance, the grease nipple can be suddenly popped out by pressurized grease.

(3) Push out master pin by using a suitable tool.

(4) Move the machine slowly in reverse, and lay out track link assembly (1).

※ Jack up the machine and put wooden block under the machine.

※ Don't get close to the sprocket side as the track shoe plate may fall down on your feet.

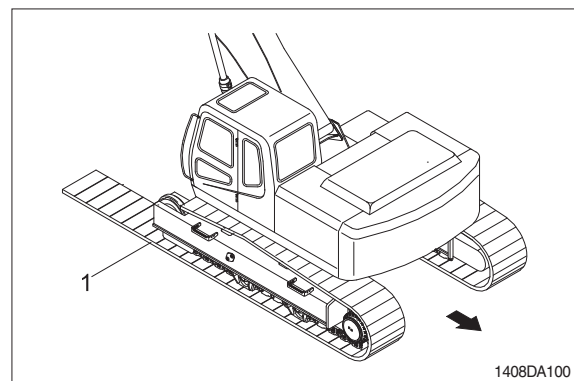
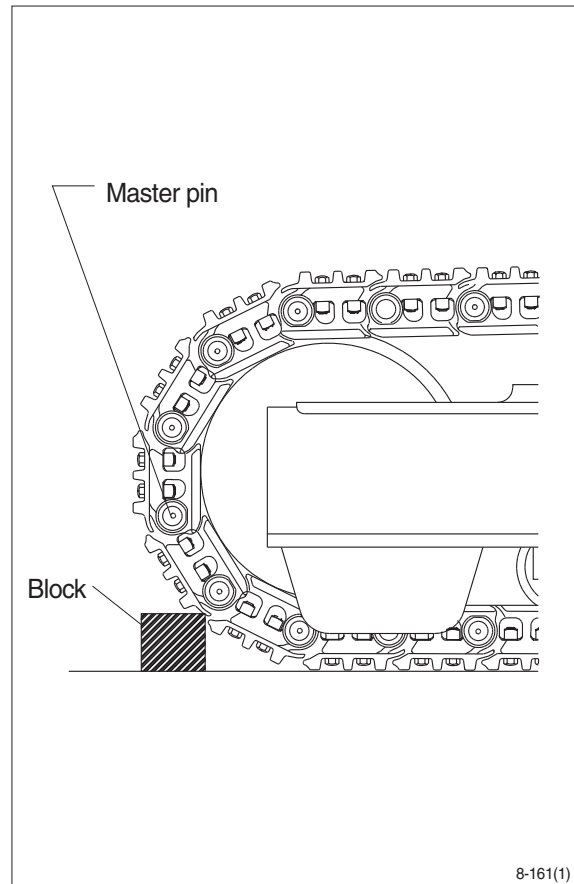

2) INSTALL

(1) Carry out installation in the reverse order to removal.

※ Adjust the tension of the track link.

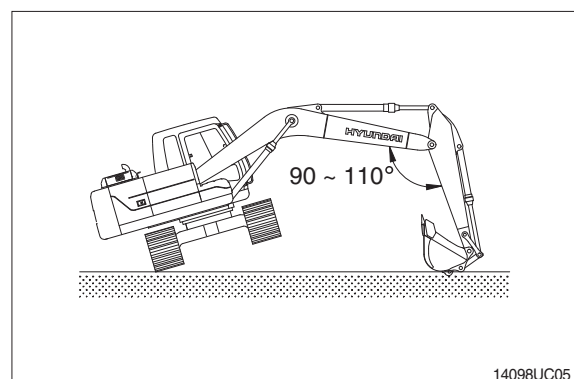

2. CARRIER ROLLER

1) REMOVAL

- (1) Loosen tension of the track link.

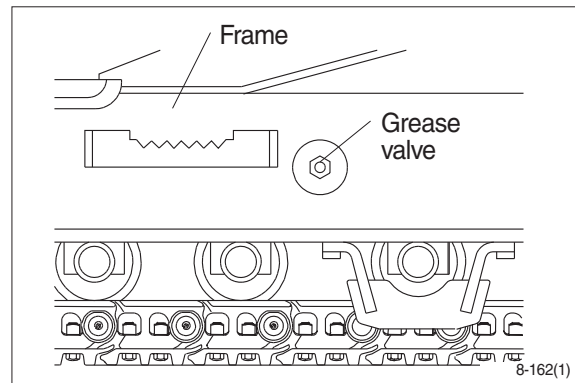

- (2) Jack up the track link height enough to permit carrier roller removal.

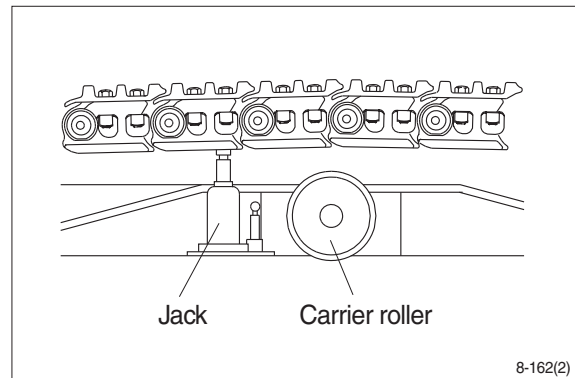

- (3) Loosen the lock nut (1).
- (4) Open bracket(2) with a screwdriver, push out from inside, and remove carrier roller assembly.
 - Weight : 19 kg (42 lb)
 - Tightening torque : 29.7 ± 4.5 kgf-m
(215 ± 32.5 lbf-ft)

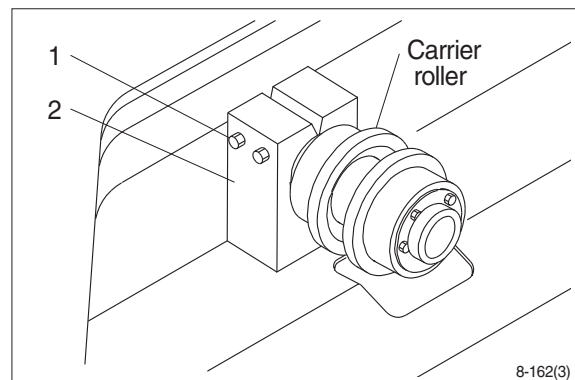

2) INSTALL

- (1) Carry out installation in the reverse order to removal.

3. TRACK ROLLER

1) REMOVAL

- (1) Loosen tension of the track link.

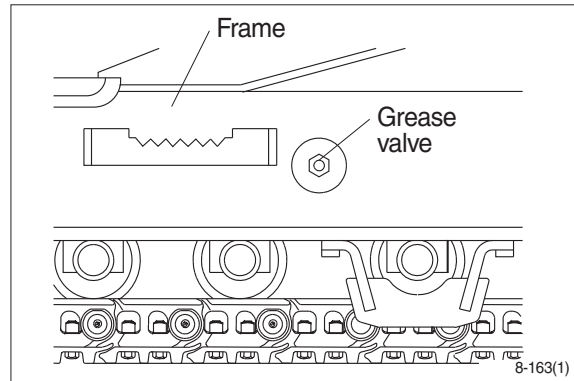

- (2) Using the work equipment, push up track frame on side which is to be removed.
※ After jack up the machine, set a block under the unit.

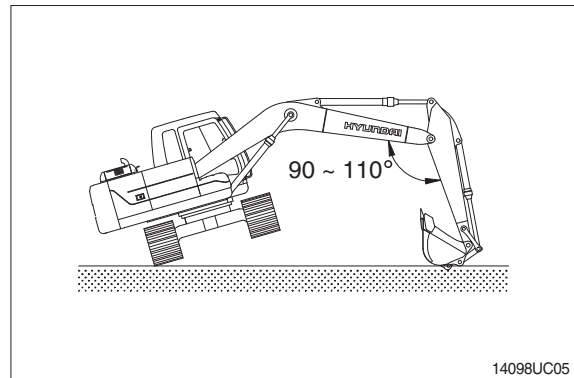

- (3) Remove the mounting bolt (1) and draw out the track roller (2).
 - Weight : 33 kg (73 lb)
 - Tightening torque : 29.7 ± 4.5 kgf·m
(215 ± 32.5 lbf·ft)

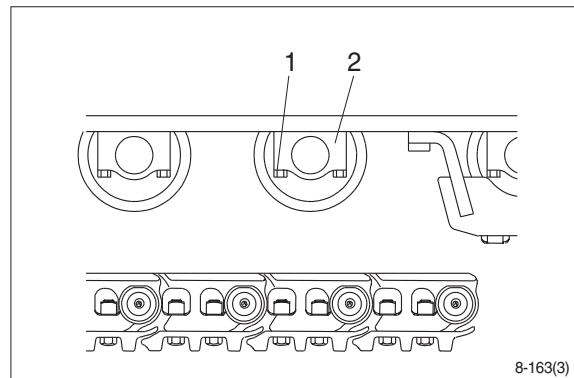

2) INSTALL

- (1) Carry out installation in the reverse order to removal.

4. IDLER AND RECOIL SPRING

1) REMOVAL

- (1) Remove the track link.
For detail, see removal of track link.

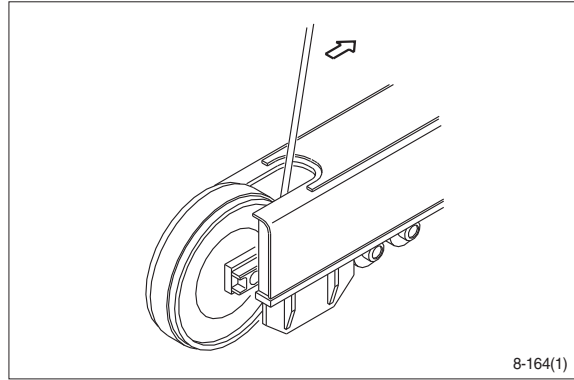

- (2) Sling the recoil spring (1) and pull out idler and recoil spring assembly from track frame, using a pry.
· Weight : 192 kg (423 lb)

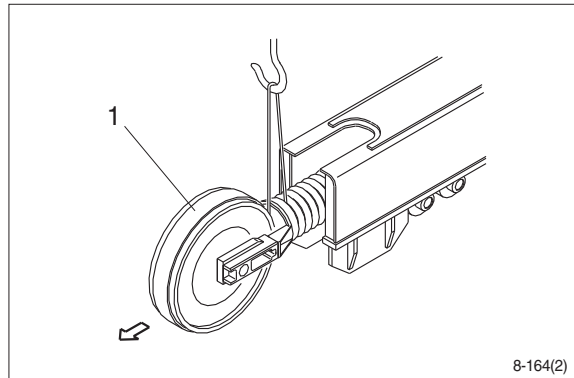

- (3) Remove the bolts (2), washers (3) and separate idler from recoil spring.
· Tightening torque : 29.7 ± 4.5 kgf·m
(215 ± 32.5 lbf·ft)

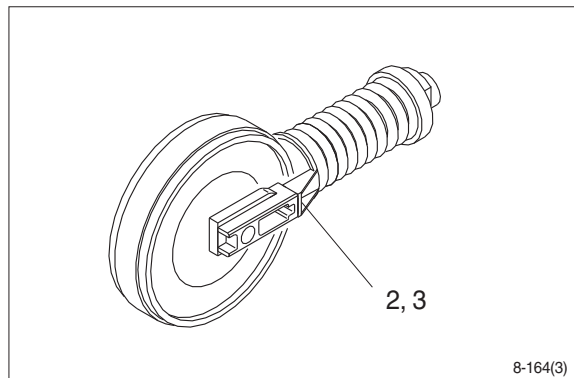

2) INSTALL

- (1) Carry out installation in the reverse order to removal.
※ Make sure that the boss on the end face of the recoil cylinder rod is in the hole of the track frame.

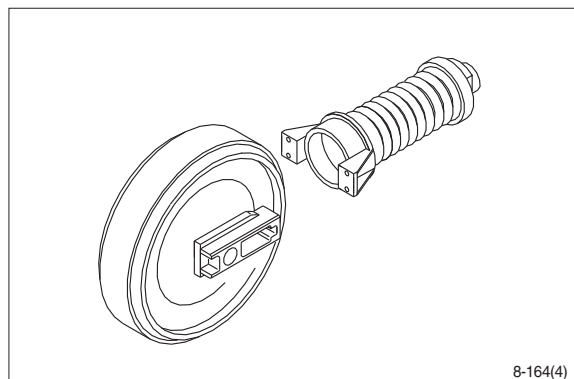

3) DISASSEMBLY AND ASSEMBLY OF IDLER

(1) Structure (standard)

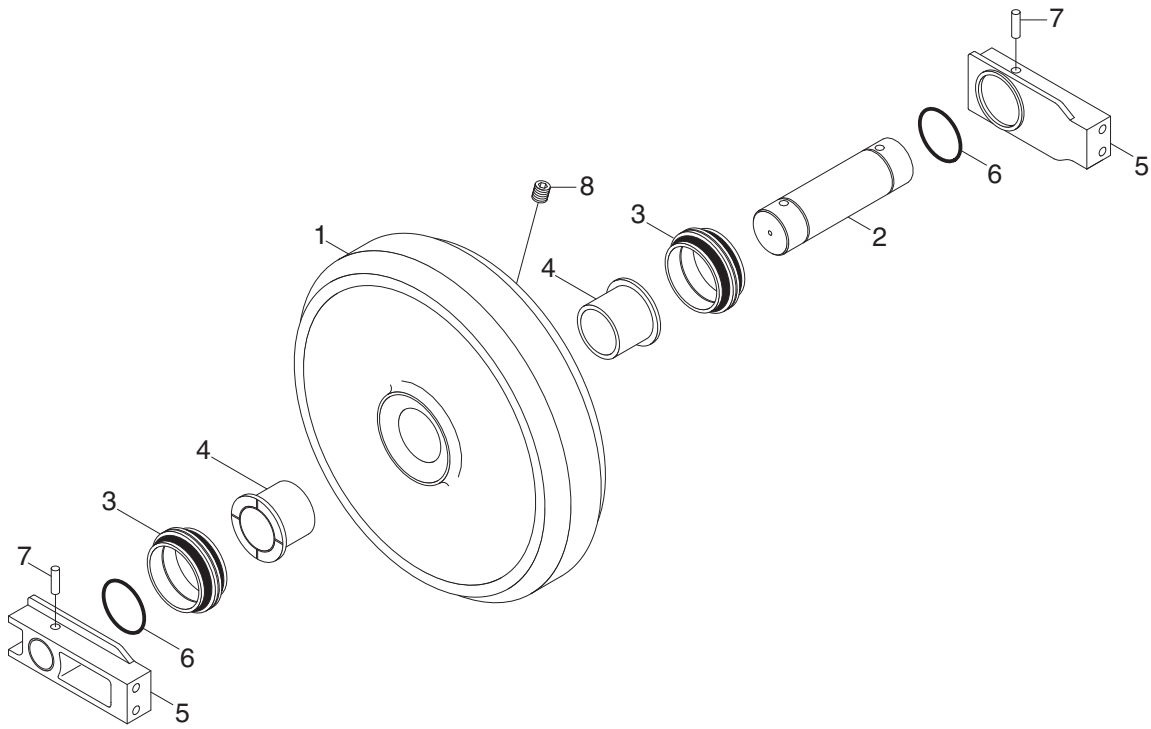

21078DA43

- 1 Shell
- 2 Shaft
- 3 Seal assembly

- 4 Bushing
- 5 Bracket
- 6 O-ring

- 7 Spring pin
- 8 Plug

(1) Structure (High walker, type 1 & 2)

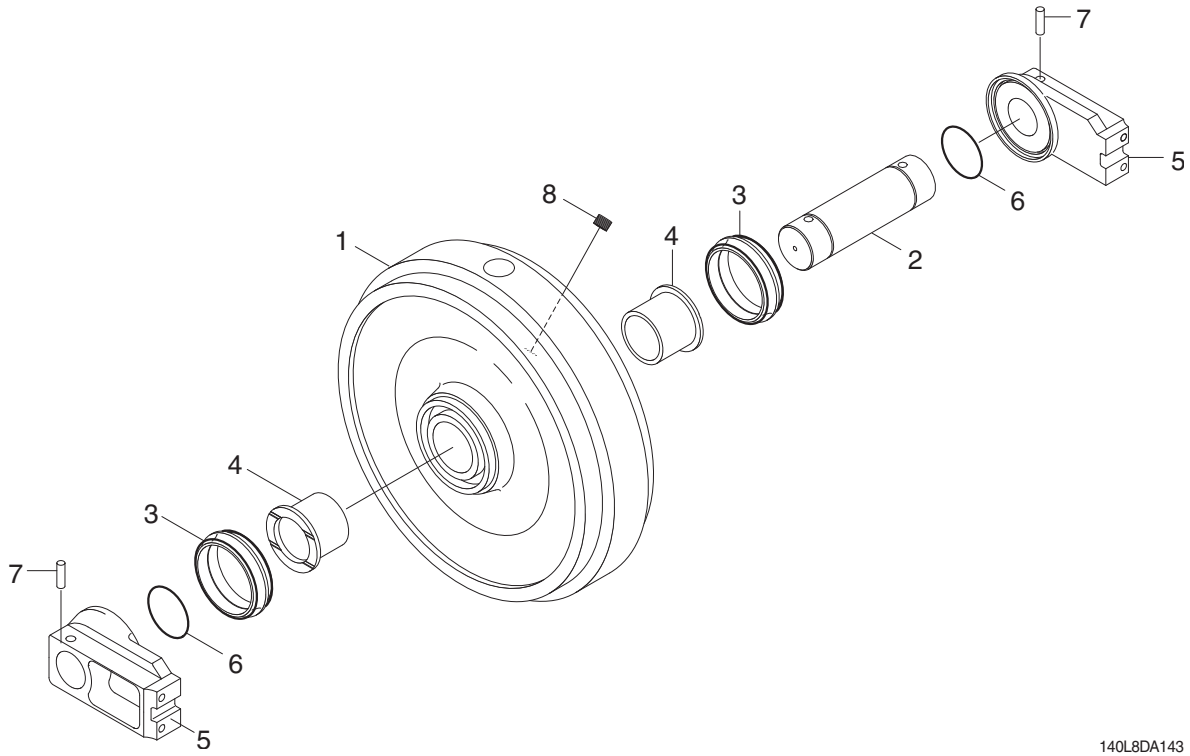

140L8DA143

- 1 Shell
- 2 Shaft
- 3 Seal assy

- 4 Bushing
- 5 Bracket
- 6 O-ring

- 7 Spring pin
- 8 Hex Plug

(2) Disassembly

※ The illustrations are base on the type 1.

- ① Remove plug and drain oil.
- ② Draw out the spring pin (7), using a press.

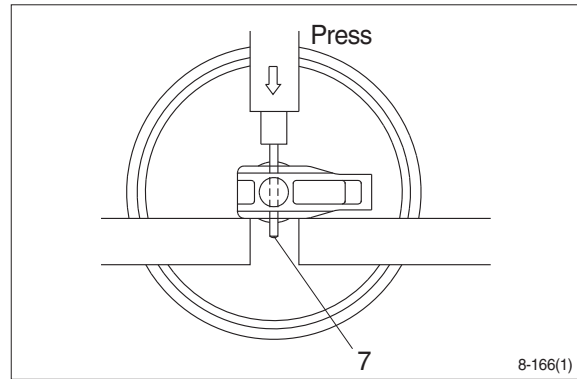

- ③ Pull out the shaft (2) with a press.
- ④ Remove seal (3) from idler (1) and bracket (5).
- ⑤ Remove O-ring (6) from shaft.

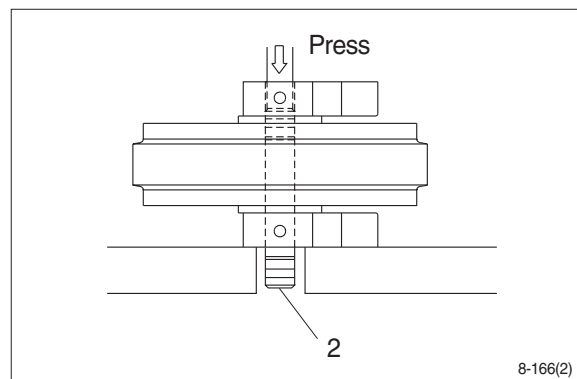

- ⑥ Remove the bushing (4) from idler, using a special tool.
Only remove bushing if replacement is necessary.

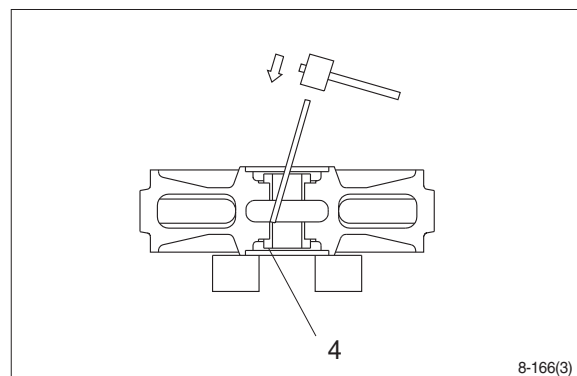

(3) Assembly

- ※ Before assembly, clean the parts.
- ※ Coat the sliding surfaces of all parts with oil.
- ① Cool up bushing (4) fully by some dry ice and press it into shell (1).
Do not press it at the normal temperature, or not knock in with a hammer even after the cooling.

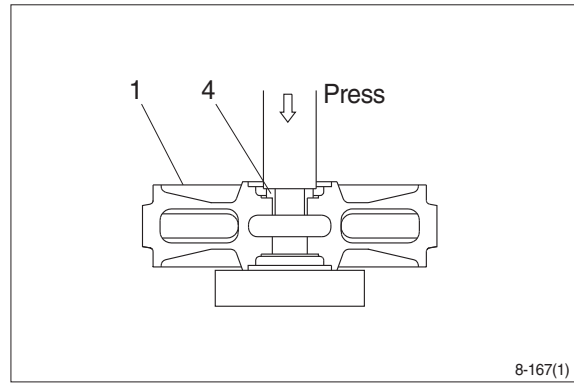

- ② Coat O-ring (6) with grease thinly, and install it to shaft (2).
- ③ Insert shaft (2) into bracket (5) and drive in the spring pin (7).

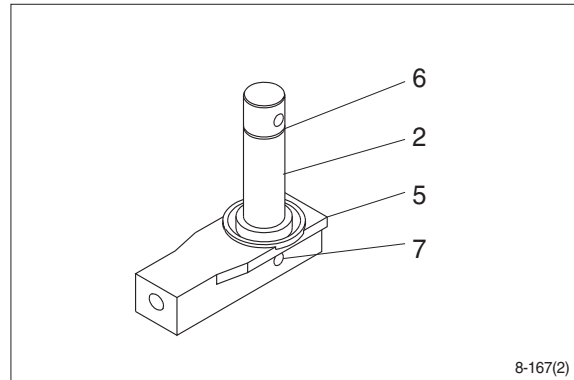

- ④ Install seal (3) to shell (1) and bracket (5).

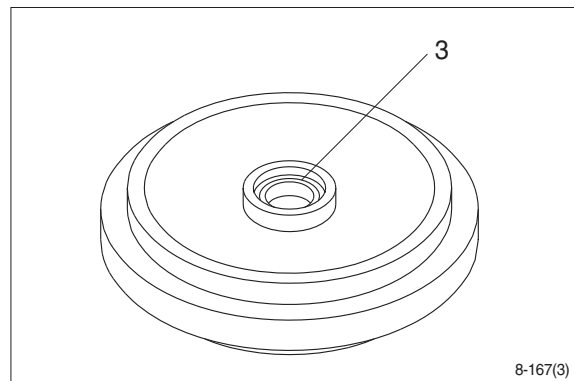

- ⑤ Install shaft (2) to shell (1).

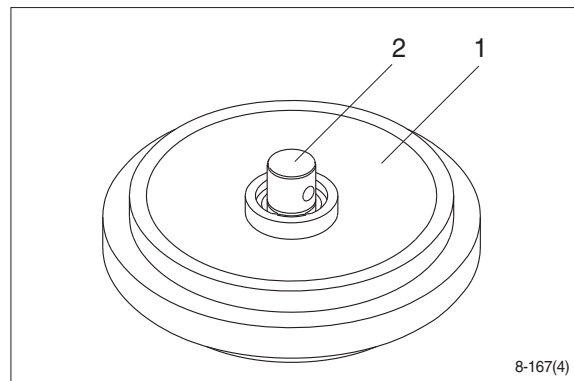

- ⑥ Install bracket (5) attached with seal (3).

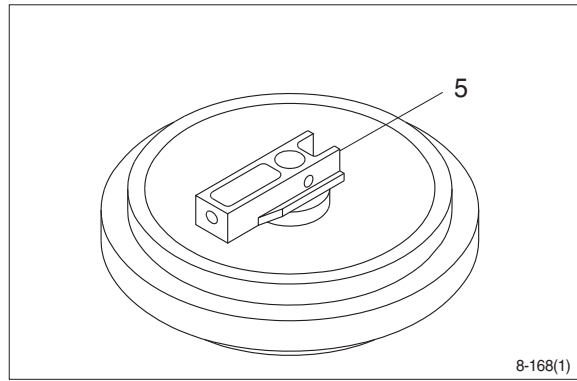

- ⑦ Knock in the spring pin (7) with a hammer.

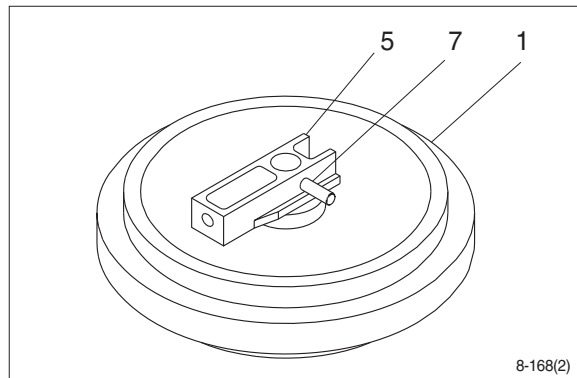

- ⑧ Lay bracket (5) on its side.
Supply engine oil to the specified level,
and tighten plug.

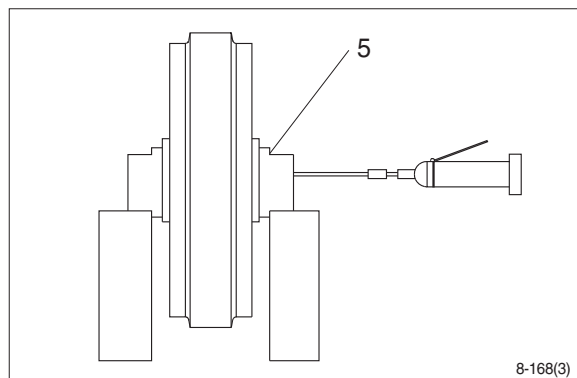

4) DISASSEMBLY AND ASSEMBLY OF RECOIL SPRING

(1) Structure (standard)

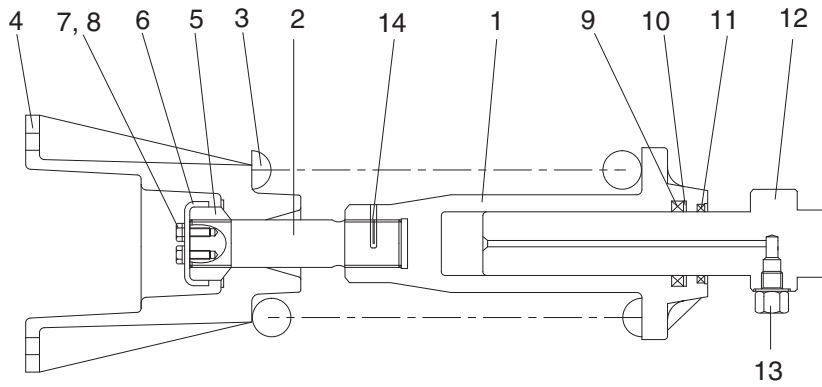

140LC8UC30

- | | | | | | |
|---|----------|----|---------------|----|--------------|
| 1 | Body | 6 | Lock plate | 11 | Dust seal |
| 2 | Tie bar | 7 | Bolt | 12 | Rod |
| 3 | Spring | 8 | Spring washer | 13 | Grease valve |
| 4 | Bracket | 9 | Rod packing | 14 | Spring pin |
| 5 | Lock nut | 10 | Back up ring | | |

Structure (High walker, type 1 & 2)

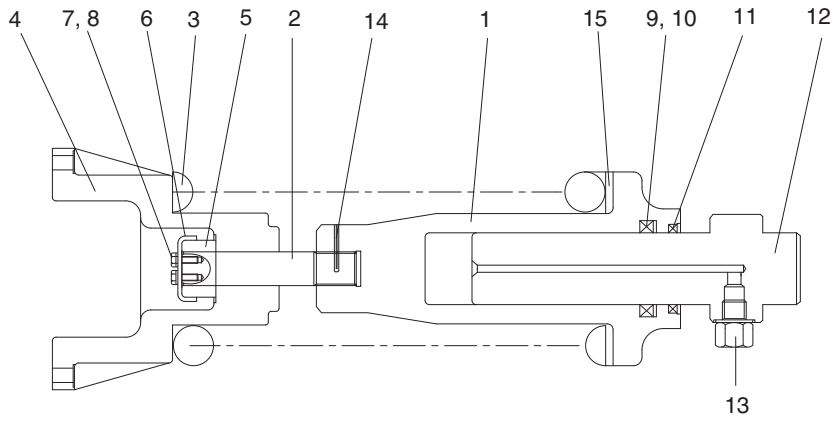

140L8UC130

- | | | | | | |
|---|----------|----|---------------|----|--------------|
| 1 | Body | 6 | Lock plate | 11 | Dust seal |
| 2 | Tie bar | 7 | Bolt | 12 | Rod assembly |
| 3 | Spring | 8 | Spring washer | 13 | Grease valve |
| 4 | Bracket | 9 | Rod seal | 14 | Spring pin |
| 5 | Lock nut | 10 | Back up ring | 15 | Spacer |

(2) Disassembly

※ The illustrations are base on the type

① 1.

Apply pressure on spring (3) with a press.

※ The spring is under a large installed load.

This is dangerous, so be sure to set

② properly.

Remove bolt (7), spring washer (8) and

③ lock plate (6).

Remove lock nut (5).

Take enough notice so that the press which pushes down the spring, should

④ not be slipped out in its operation.

Lighten the press load slowly and remove

bracket (4) and spring (3).

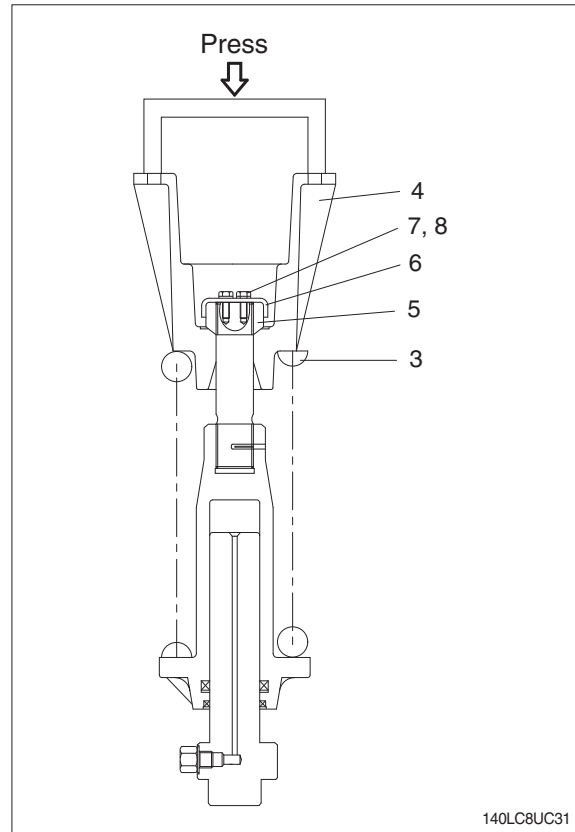

⑤ Remove rod (12) from body (1).

⑥ Remove grease valve (13) from rod (12).

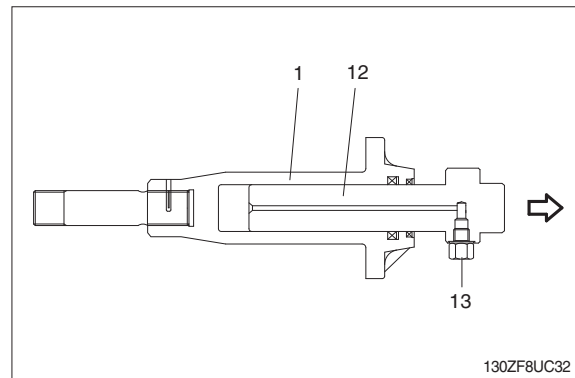

⑦ Remove rod seal (9), back up ring (10) and dust seal (11).

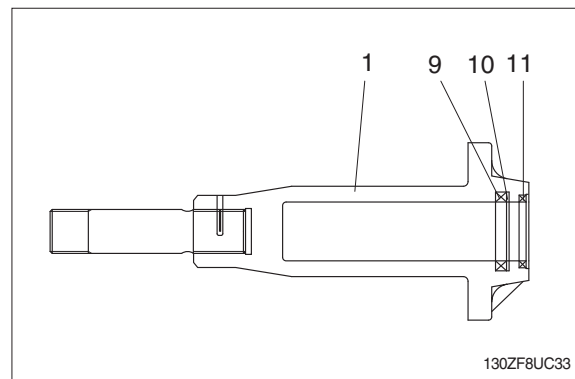

(3) Assembly

Install dust seal (11), back up ring (10) and rod seal (9) to body (1).

- ※ When installing dust seal (11) and rod seal (9), take full care so as not to damage the lip.

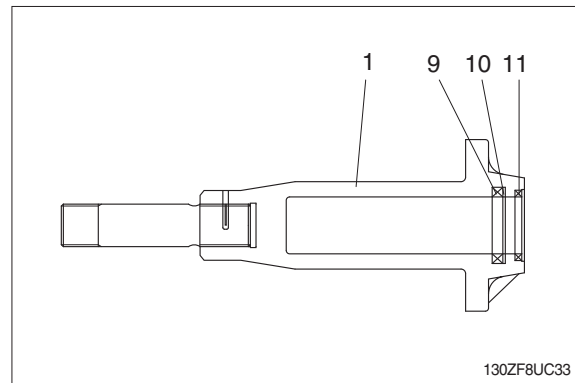

② Pour grease into body (1), then push in rod (12) by hand.

After take grease out of grease valve mounting hole, let air out.

- ※ If air letting is not sufficient, it may be difficult to adjust the tension of crawler.

③ Fit grease valve (13) to rod (12).

- Tightening torque : $13.0 \pm 0.5 \text{ kgf} \cdot \text{m}$
($94.0 \pm 3.6 \text{ lbf} \cdot \text{ft}$)

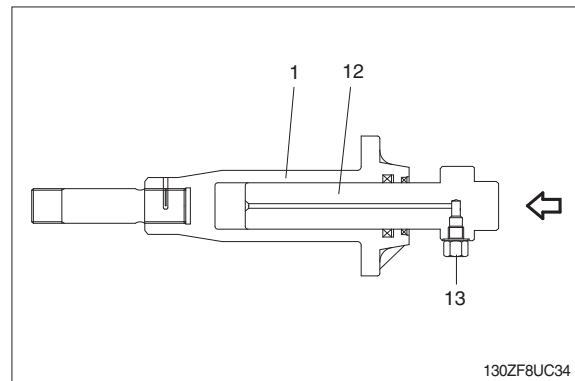

④ Install spring (3) and bracket (4) to body (1).

⑤ Apply pressure to spring (3) with a press and tighten lock nut (5).

- Spring set load
 - Standard : 8497 kg (18733 lb)
 - High walker : 11908 kg (26253 lb)

- ※ Apply sealant before assembling.
- ※ During the operation, pay attention specially to prevent the press from slipping out.

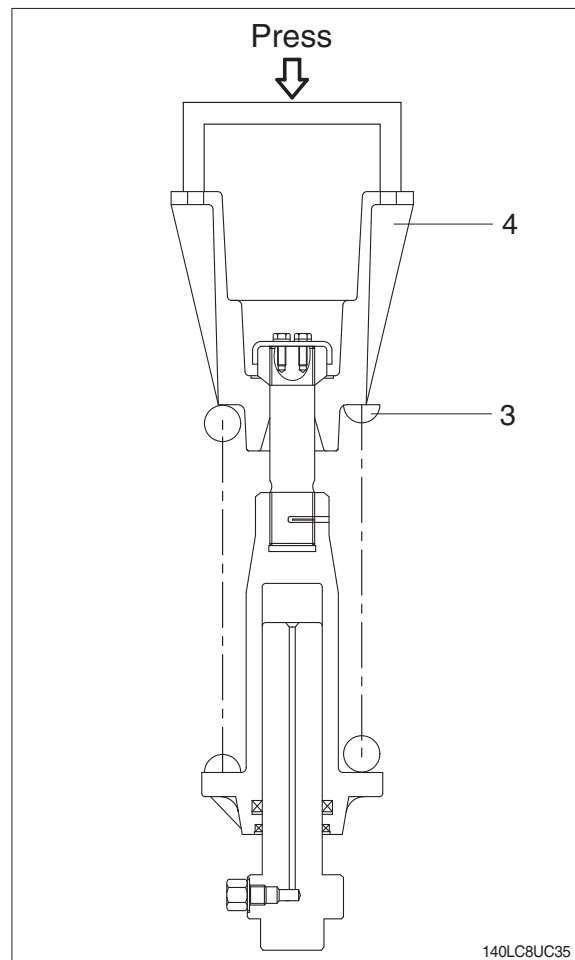

- ⑥ Lighten the press load and confirm the set length of spring (3).
- Standard : 405 ± 1.5 mm
 - High walker : 420 ± 1.5 mm
- ⑦ After the setting of spring (3), install lock plate (6), spring washer (8) and bolt (7).
- Tightening torque : 15 ± 0.5 kgf·m
(108 ± 3.6 lbf·ft)

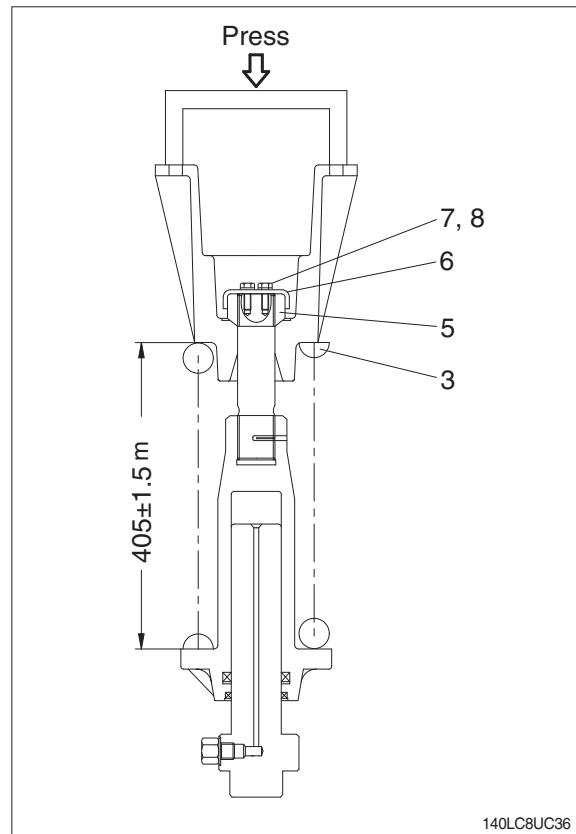

GROUP 11 WORK EQUIPMENT

1. STRUCTURE

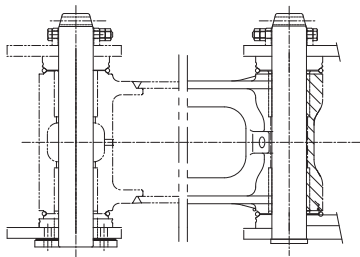
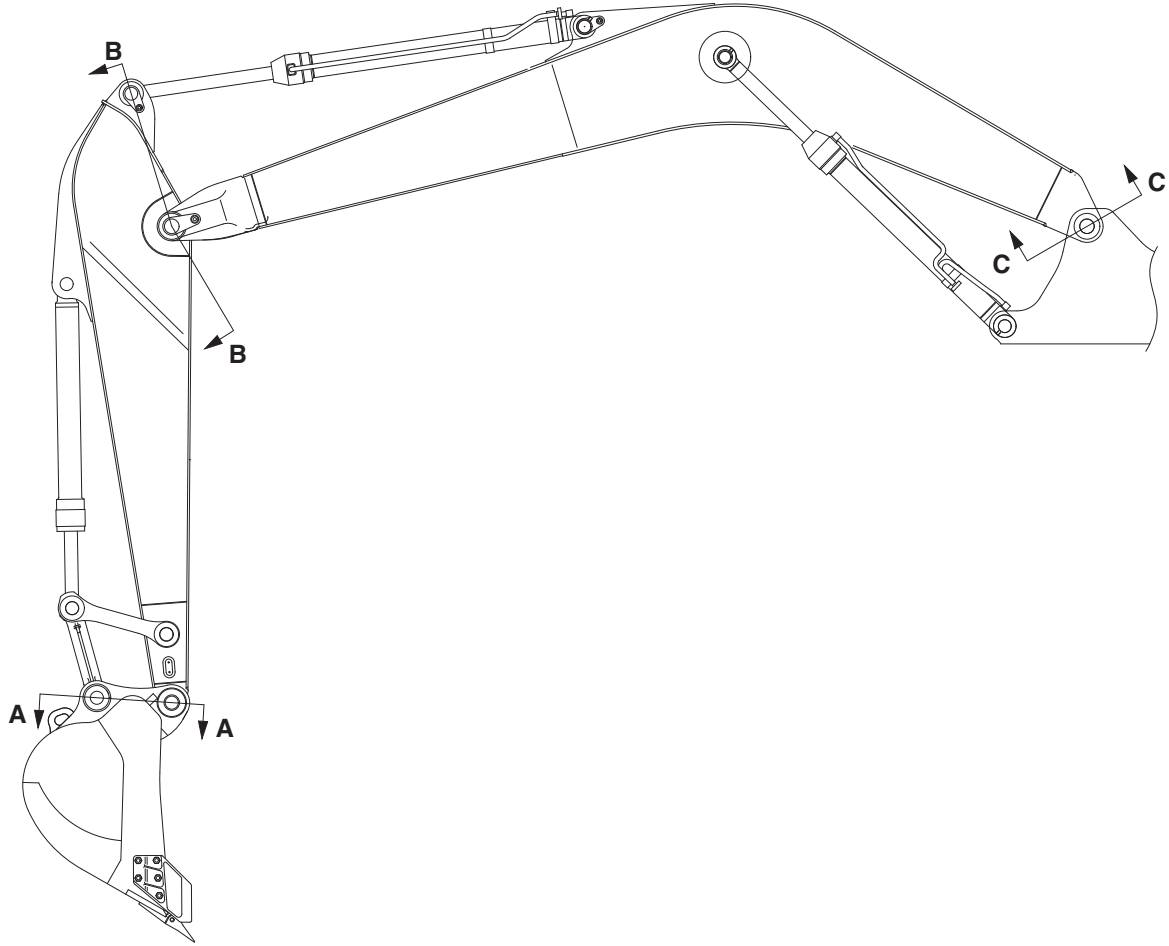

SECTION A

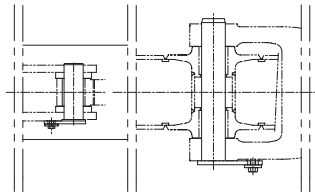

SECTION B

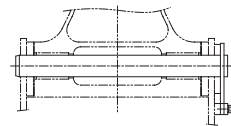

SECTION C

21078DA44

2. REMOVAL AND INSTALL

1) BUCKET ASSEMBLY

(1) Removal

- ① Lower the work equipment completely to ground with back of bucket facing down.

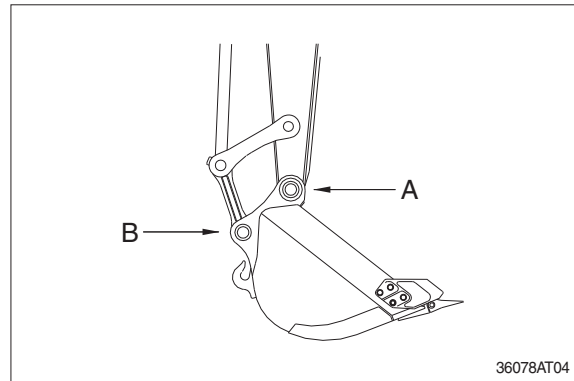

- ② Remove nut (1), bolt (2) and draw out the pin (B).

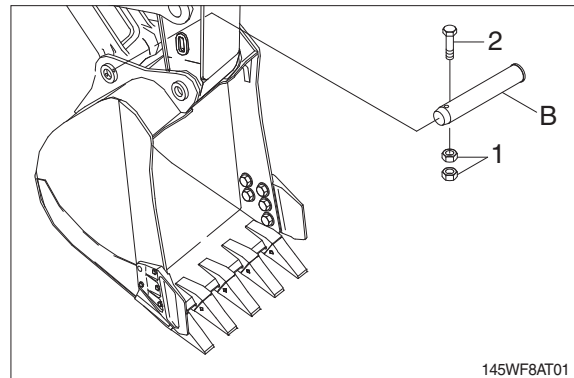

- ③ Remove nut (3), bolt (4) and draw out the pin (A) then remove the bucket assembly.
 - Weight : 480 kg (1060 lb)
 - Tightening torque : 29.7 ± 4.5 kgf·m
(215 ± 32.5 lbf·ft)

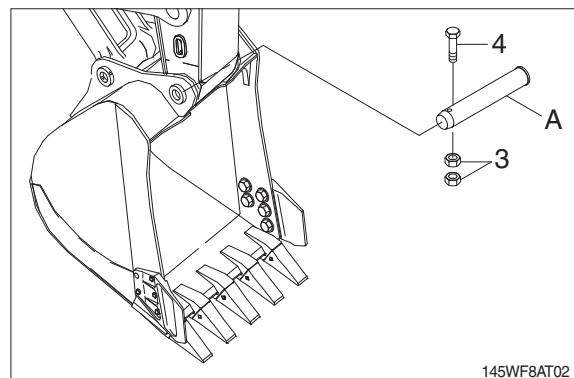

(2) Install

- ① Carry out installation in the reverse order to removal.
- ▲ When aligning the mounting position of the pin, do not insert your fingers in the pin hole.**
- ※ Adjust the bucket clearance.
For detail, see operation manual.

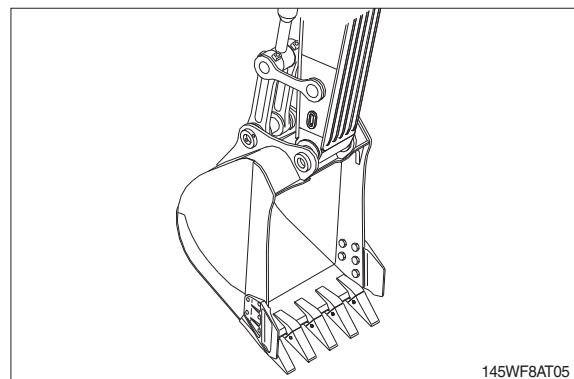

2) ARM ASSEMBLY

(1) Removal

※ Loosen the breather slowly to release the pressure inside the hydraulic tank.

▲ Escaping fluid under pressure can penetrate the skin causing serious injury.

① Remove bucket assembly.

For details, see removal of bucket assembly.

② Disconnect bucket cylinder hose (1).

▲ Fit blind plugs (5) in the piping at the chassis end securely to prevent oil from spurting out when the engine is started.

③ Sling arm cylinder assembly, remove spring, pin stopper and pull out pin.

※ Tie the rod with wire to prevent it from coming out.

④ For details, see removal of arm cylinder assembly.

Place a wooden block under the cylinder and bring the cylinder down to it.

⑤ Remove bolt (2), plate (3) and pull out the pin (4) then remove the arm assembly.

· Weight : 570 kg (1260 lb)

· Tightening torque : 12.8 ± 3.0 kgf·m
(92.6 ± 21.7 lbf·ft)

※ When lifting the arm assembly, always lift the center of gravity.

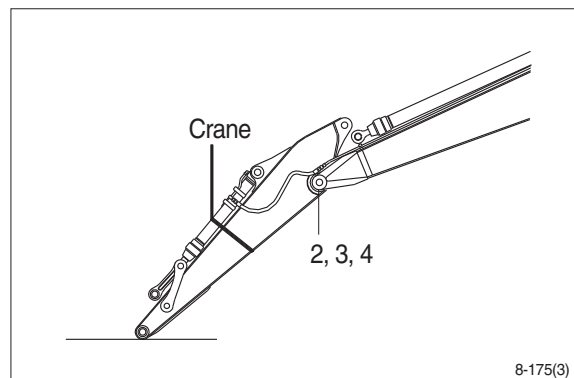
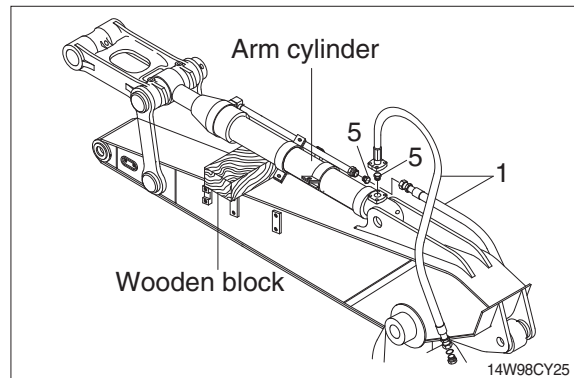
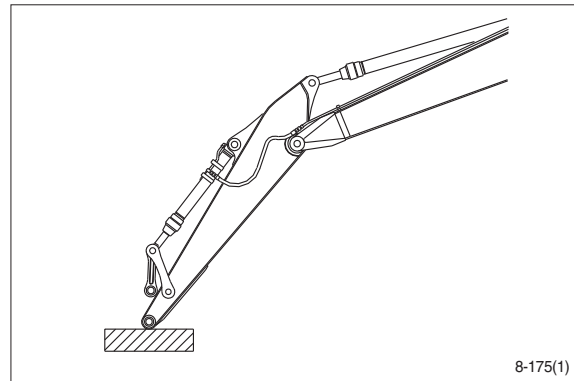

(2) Install

① Carry out installation in the reverse order to removal.

▲ When lifting the arm assembly, always lift the center of gravity.

※ Bleed the air from the cylinder.

3) BOOM CYLINDER

(1) Removal

- ① Remove arm and bucket assembly.
For details, see removal of arm and bucket assembly.
- ② Remove boom cylinder assembly from boom.
For details, see removal of arm cylinder assembly.

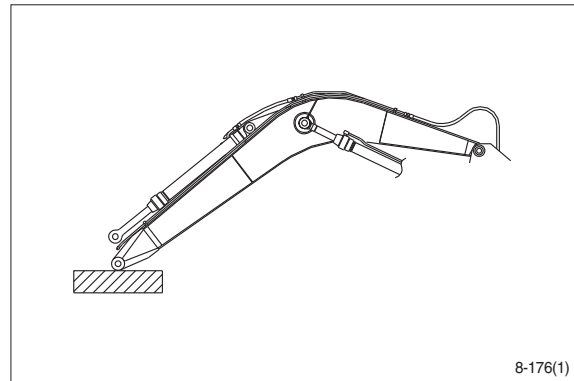

- ③ Disconnect head lamp wiring.
- ④ Disconnect bucket cylinder hose (2) and arm cylinder hose (1).
- ※ When the hose are disconnected, oil may spurt out.
- ⑤ Sling boom assembly (3).

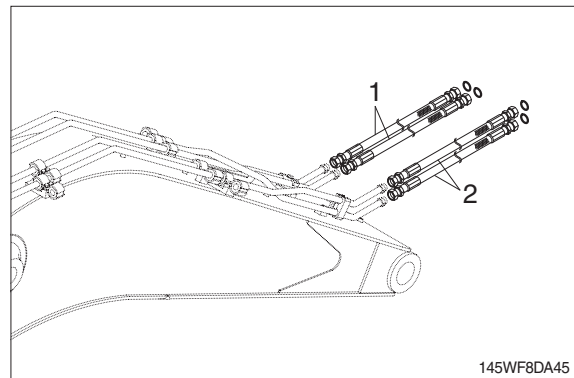

- ⑥ Remove bolt (4), plate (5) and pull out the pin (6) then remove boom assembly.
 - Weight : 1020 kg (2250 lb)
 - Tightening torque : 12.8 ± 3.0 kgf·m
(92.6 ± 21.7 lbf·ft)
- ※ When lifting the boom assembly always lift the center of gravity.

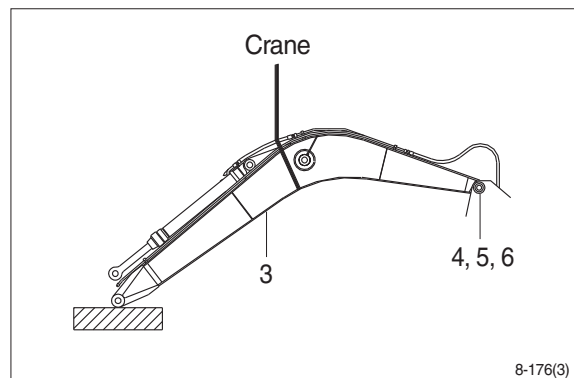

(2) Install

- ① Carry out installation in the reverse order to removal.
- ▲ When lifting the arm assembly, always lift the center of gravity.
- ※ Bleed the air from the cylinder.

