

SECTION 6 MAINTENANCE STANDARD

Group 1 Operational Performance Test	6-1
Group 2 Major Components	6-19

SECTION 6 MAINTENANCE STANDARD

GROUP 1 OPERATIONAL PERFORMANCE TEST

1. PURPOSE

Performance tests are used to check:

1) OPERATIONAL PERFORMANCE OF A NEW MACHINE

Whenever a new machine is delivered in parts and reassembled at a customer's site, it must be tested to confirm that the operational performance of the machine meets HD Hyundai Construction Equipment spec.

2) OPERATIONAL PERFORMANCE OF A WORKING MACHINE

With the passage of time, the machine's operational performance deteriorates, so that the machine needs to be serviced periodically to restore it to its original performance level.

Before servicing the machine, conduct performance tests to check the extent of deterioration, and to decide what kind of service needs to be done (by referring to the "Service Limits" in this manual).

3) OPERATIONAL PERFORMANCE OF A REPAIRED MACHINE

After the machine is repaired or serviced, it must be tested to confirm that its operational performance was restored by the repair and/or service work done.

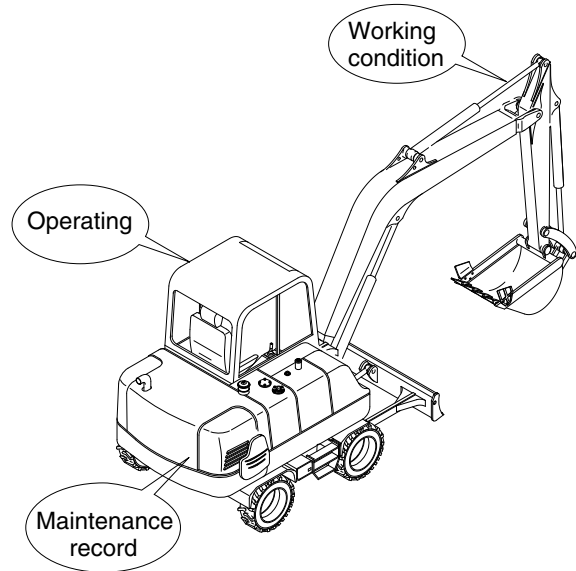

55W76MS01

2. TERMINOLOGY

1) STANDARD

Specifications applied to the brand-new machine, components and parts.

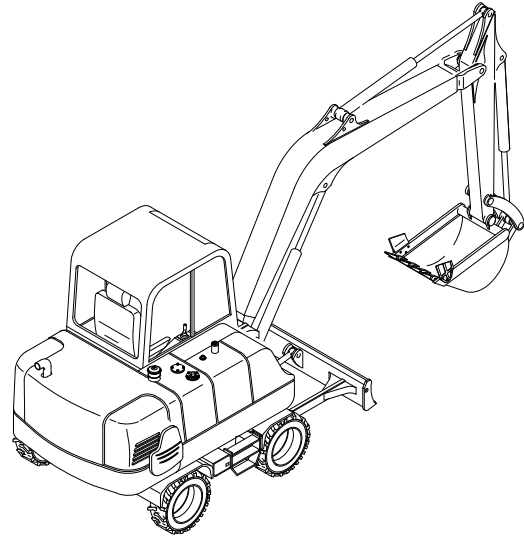

55W76MS02

2) SERVICE LIMIT

The lowest acceptable performance level. When the performance level of the machine falls below this level, the machine must be removed from work and repaired. Necessary parts and components must be replaced.

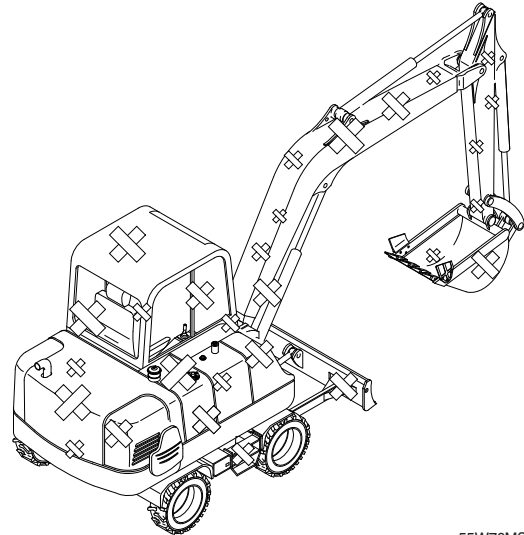

55W76MS03

3. OPERATION FOR PERFORMANCE TESTS

- 1) Observe the following rules in order to carry out performance tests accurately and safely.

(1) The machine

Repair any defects and damage found, such as oil or water leaks, loose bolts, cracks and so on, before starting to test.

(2) Test area

- ① Select a hard, flat surface.
- ② Secure enough space to allow the machine to run straight more than 20m, and to make a full swing with the front attachment extended.
- ③ If required, rope off the test area and provide signboards to keep unauthorized personnel away.

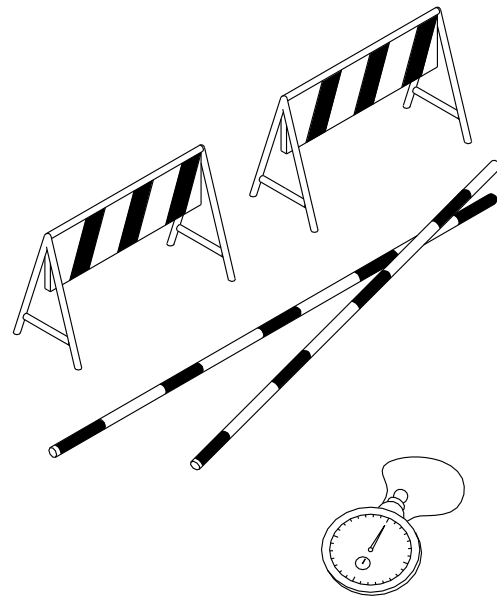

(3) Precautions

- ① Before starting to test, agree upon the signals to be employed for communication among coworkers. Once the test is started, be sure to communicate with each other using these signals, and to follow them without fail.
- ② Operate the machine carefully and always give first priority to safety.
- ③ While testing, always take care to avoid accidents due to landslides or contact with high voltage power lines. Always confirm that there is sufficient space for full swings.
- ④ Avoid polluting the machine and the ground with leaking oil. Use oil pans to catch escaping oil. Pay special attention to this when removing hydraulic pipings.

7-3 (140-7)

(4) Make precise measurements

- ① Accurately calibrate test instruments in advance to obtain correct data.
- ② Carry out tests under the exact test conditions prescribed for each test item.
- ③ Repeat the same test and confirm that the test data obtained can be procured repeatedly. Use mean values of measurements if necessary.

2) ENGINE SPEED

- (1) Measure the engine speed at each power mode
- ※ The engine speed at each power mode must meet standard RPM; if not, all other operational performance data will be unreliable. It is essential to perform this test first.

(2) Preparation

- ① Warm up the machine, until the engine coolant temperature reaches 50°C or more, and the hydraulic oil is 50 ± 5°C.
- ② Set the accel dial at 10 (Max) position.
- ③ Measure the engine RPM.

(3) Measurement

- ① Start the engine. The engine will run at start idle speed. Measure engine speed with a engine rpm display.
- ② Measure and record the engine speed at each mode (P, S).
- ③ Select the P-mode.
- ④ Lightly operate the bucket control lever a few times, then return the control lever to neutral; The engine will automatically enter the auto-idle speed after 4 seconds.
- ⑤ Measure and record the auto deceleration speed.

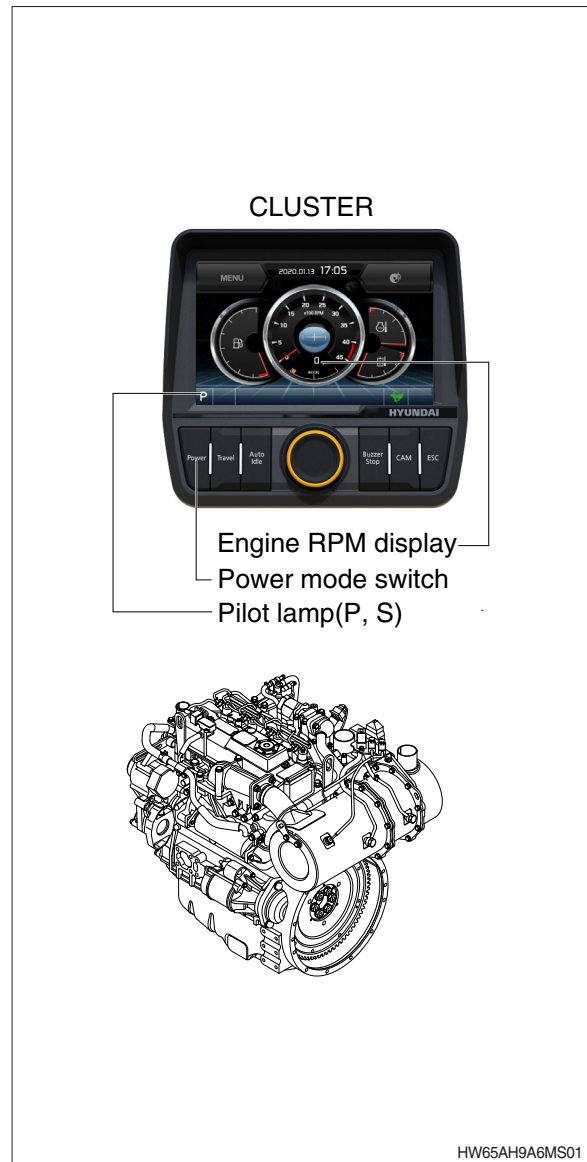

(4) Evaluation

The measured speeds should meet the following specifications.

Unit : rpm

Model	Engine speed	Standard	Remark
HW65AH	Start idle	1000 ± 50	
	P mode	2300 ± 50	
	S mode	1950 ± 50	
	Auto decel	1100 ± 50	

Condition : Set the accel dial at 10 (Max) position.

3) TRAVEL SPEED

(1) Measure the time required for the excavator to travel a 50m at high speed and a 20m at low speed test run.

(2) Preparation

- ① Adjust the pressure of both tires to be equal.
- ② Prepare a flat and solid test track 50m in length, with extra length of 150m for machine acceleration.
- ③ Set the traveling position as figure.
- ④ Keep the hydraulic oil temperature at $50 \pm 5^{\circ}\text{C}$.

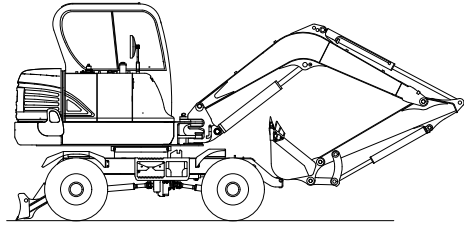

555W96MS04

(3) Measurement

- ① Measure both the low and high speed of the machine.
- ② Before starting either the low or high speed tests, adjust the RH multifunction switch to the speed to be tested.
- ③ Start traveling the machine in the extra length with the two speed switch at high or low speed.
- ④ Measure the time required to travel 50m at high speed or 20m at low speed.
- ⑤ After measuring the forward travel speed, turn the upperstructure 180° and measure the reverse travel speed.
- ⑥ Repeat steps ④ and ⑤ three times in each direction and calculate the average values.

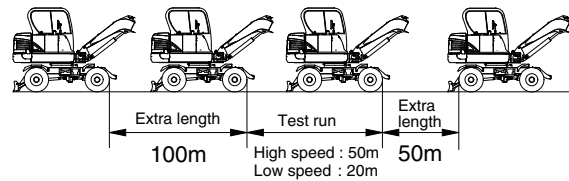

555W96MS05

(4) Evaluation

The average measured time should meet the following specifications.

Unit : Seconds

Model	Travel speed	Standard	Maximum allowable	Remarks
HW65AH	Low speed	5.5 ± 0.5	7.9	Seconds/20m
	High speed	6.0 ± 0.5	8.4	Seconds/50m

4) SWING SPEED

(1) Measure the time required to swing three complete turns.

(2) Preparation

- ① Check the lubrication of the swing gear and swing bearing.
- ② Place the machine on flat, solid ground with ample space for swinging. Do not conduct this test on slopes.
- ③ Lower the dozer blade at ground.
- ④ With the arm rolled out and bucket rolled in, hold the bucket so that the height of the bucket pin is the same as the boom foot pin. The bucket must be empty.
- ⑤ Keep the hydraulic oil temperature at $50 \pm 5^{\circ}\text{C}$.

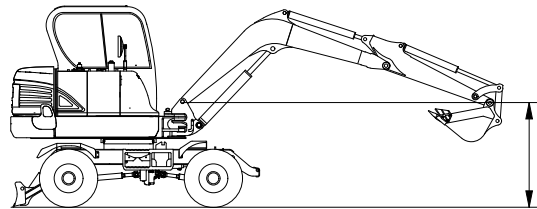

555W96MS07

(3) Measurement

- ① Operate swing control lever fully.
- ② Swing 1 turn and measure time taken to swing next 2 revolutions.
- ③ Repeat steps ① and ② three time and calculate the average values.

(4) Evaluation

The time required for 2 swings should meet the following specifications.

Unit : Seconds / 2 revolutions

Model	Standard	Maximum allowable	Remark
HW65AH	13.9 ± 1.0	17.4	-

5) SWING FUNCTION DRIFT CHECK

- (1) Measure the swing drift on the bearing outer circumference when stopping after a 360° full speed swing.

(2) Preparation

- ① Check the lubrication of the swing gear and swing bearing.
- ② Place the machine on flat, solid ground with ample space for swinging. Do not conduct this test on slopes.
- ③ Lower the dozer blade at ground.
- ④ With the arm rolled out and bucket rolled in, hold the bucket so that the height of the bucket pin is the same as the boom foot pin. The bucket must be empty.
- ⑤ Make two chalk marks: one on the swing bearing and one directly below it on the track frame.
- ⑥ Swing the upperstructure 360°.
- ⑦ Keep the hydraulic oil temperature at $50 \pm 5^{\circ}\text{C}$.

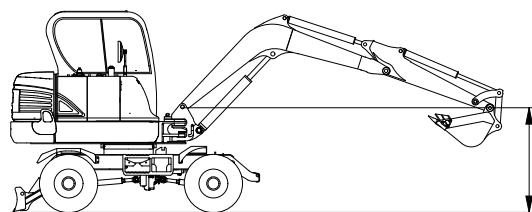

555W96MS07

(3) Measurement

- ① Operate the swing control lever fully and return it to the neutral position when the mark on the upperstructure aligns with that on track frame after swinging 360°.
- ② Measure the distance between the two marks.
- ③ Align the marks again, swing 360°, then test the opposite direction.
- ④ Repeat steps ② and ③ three times each and calculate the average values.

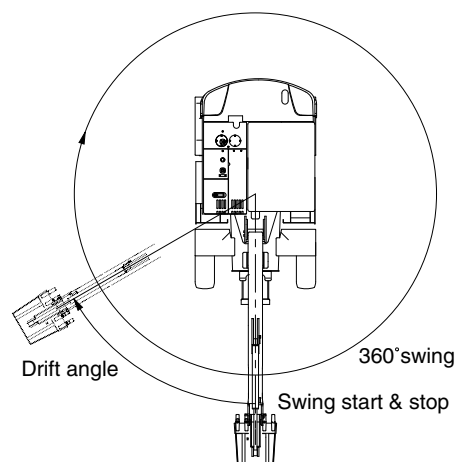

55W76MS08

(4) Evaluation

The measured drift angle should be within the following specifications.

Unit : Degree

Model	Standard	Maximum allowable	Remark
HW65AH	45 below	60	-

6) SWING BEARING PLAY

(1) Measure the swing bearing play using a dial gauge to check the wear of bearing races and balls.

(2) Preparation

- ① Check swing bearing mounting cap screws for loosening.
- ② Check the lubrication of the swing bearing. Confirm that bearing rotation is smooth and without noise.
- ③ Install a dial gauge on the track frame as shown, using a magnetic base.
- ④ Position the upperstructure so that the boom aligns with the tracks facing towards the front axle.
- ⑤ Position the dial gauge so that its needle point comes into contact with the bottom face of the bearing outer race.
- ⑥ Bucket should be empty.

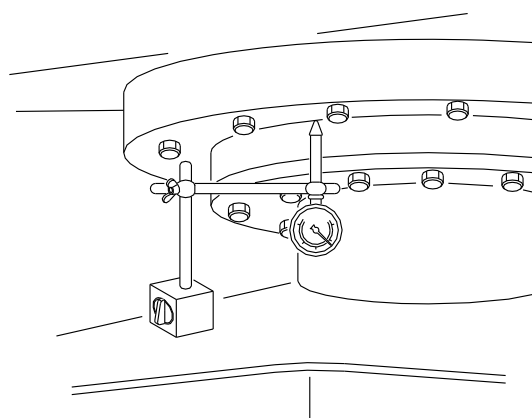

7-10(1) 140-7

(3) Measurement

- ① With the arm rolled out and bucket rolled in, hold the bottom face of the bucket to the same height of the boom foot pin. Record the dial gauge reading (h1).
- ② Lower the bucket to the ground and use it to raise the front axle 50 cm. Record the dial gauge reading (h2).
- ③ Calculate bearing play (H) from this data (h1 and h2) as follows.

$$H = h2 - h1$$

Measurement : h1

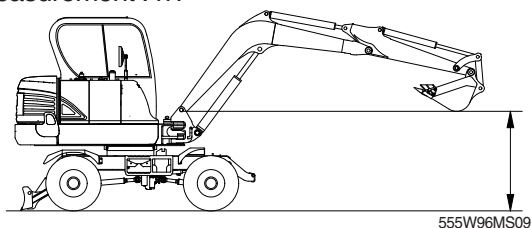

Measurement : h2

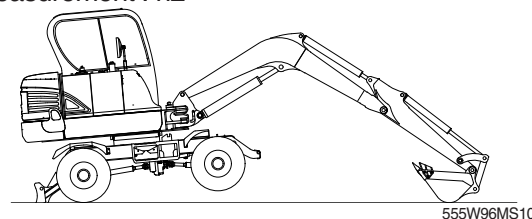

(4) Evaluation

The measured drift should be within the following specifications.

Unit : mm

Model	Standard	Maximum allowable	Remark
HW65AH	0.5 ~ 1.2	2.4	

7) HYDRAULIC CYLINDER CYCLE TIME

(1) Measure the cycle time of the boom, standard arm, and standard bucket cylinders.

(2) Preparation

① To measure the cycle time of the boom cylinder.

With the arm rolled out and the empty bucket rolled out, lower the bucket to the ground, as shown.

② To measure the cycle time of the arm cylinder.

With the empty bucket rolled in, position the arm so that it is vertical to the ground. Lower the boom until the bucket is 0.5m above the ground.

③ To measure the cycle time of the bucket cylinder.

The empty bucket should be positioned at midstroke between roll-in and roll-out, so that the sideplate edges are vertical to the ground.

④ Keep the hydraulic oil temperature at $50 \pm 5^\circ\text{C}$.

(3) Measurement

① To measure cylinder cycle times.

- Boom cylinder.

Measure the time it takes to raise the boom, and the time it takes to lower the boom. To do so, position the boom at one stroke end then move the control lever to the other stroke end as quickly as possible.

- Arm cylinder.

Measure the time it takes to roll in the arm, and the time it takes to roll out the arm. To do so, position the bucket at one stroke end, then move the control lever to the other stroke end as quickly as possible.

Boom cylinder

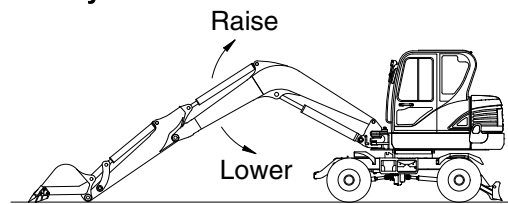

Arm cylinder

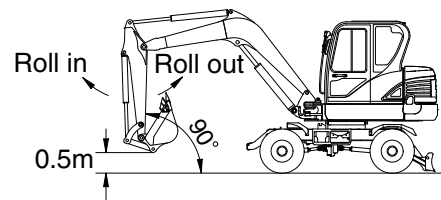

Bucket cylinder

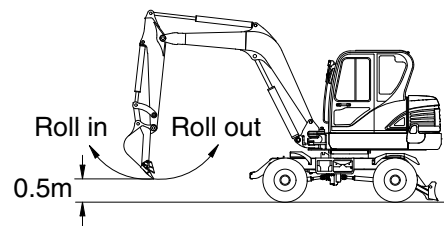

555W96MS11

- Bucket cylinders

Measure the time it takes to roll in the bucket, and the time it takes to roll out the bucket. To do so, position the bucket at one stroke end, then move the control lever to the other stroke end as quickly as possible.

- Repeat each measurement 3 times and calculate the average values.

(4) Evaluation

The average measured time should meet the following specifications.

Unit : Seconds

Model	Function	Standard	Maximum allowable	Remarks
HW65AH	Boom raise	2.2±0.4	2.8	
	Boom lower	2.6±0.4	3.3	
	Arm in	2.3±0.4	2.9	
	Arm out	2.2±0.3	2.8	
	Bucket load	3.5±0.3	4.4	
	Bucket dump	2.3±0.4	2.9	
	Boom swing (LH)	4.6±0.7	5.75	
	Boom swing (RH)	5.5±0.7	6.9	
	Dozer up (raise)	2.3±0.3	2.9	
	Dozer down (lower)	2.8±0.3	3.5	

8) DIG FUNCTION DRIFT CHECK

- (1) Measure dig function drift, which can be caused by oil leakage in the control valve and boom, standard arm, and standard bucket cylinders, with the loaded bucket. When testing the dig function drift just after cylinder replacement, slowly operate each cylinder to its stroke end to purge air.

(2) Preparation

- ① Load bucket fully. Instead of loading the bucket, weight (W) of the following specification can be used.

$$W = M^3 \times 1.5$$

Where :

M^3 = Bucket heaped capacity (m³)

1.5 = Soil specific gravity

- ② Position the arm cylinder with the rod 20 to 30 mm extended from the fully retracted position.
- ③ Position the bucket cylinder with the rod 20 to 30 mm retracted from the fully extended position.
- ④ With the arm rolled out and bucket rolled in, hold the bucket so that the height of the bucket pin is the same as the boom foot pin.
- ⑤ Keep the hydraulic oil temperature at $50 \pm 5^\circ\text{C}$.

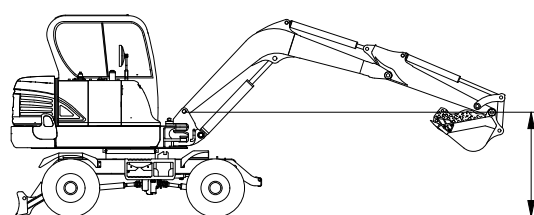

555W96MS12

(3) Measurement

- ① Stop the engine.
- ② Five minutes after the engine has been stopped, measure the changes in the positions of the boom, arm and bucket cylinders.
- ③ Repeat step ② three times and calculate the average values.

- (4) The measured drift should be within the following specifications.

Unit : mm / 5min

Model	Drift to be measured	Standard	Maximum allowable	Remarks
HW65AH	Boom cylinder	10 below	5	
	Arm cylinder	20 below	5	
	Bucket cylinder	20 below	5	
	Dozer cylinder	10 below	15	

9) CONTROL LEVER OPERATING FORCE

(1) Use a spring scale to measure the maximum resistance of each control lever at the middle of the grip.

(2) Preparation

① Keep the hydraulic oil temperature at $50 \pm 5^\circ\text{C}$.

(3) Measurement

- ① Start the engine.
- ② Operate each boom, arm, bucket and swing lever at full stroke and measure the maximum operating force for each.
- ③ Repeat steps ② three times and calculate the average values.

(4) Evaluation

The measured operating force should be within the following specifications.

Unit : kgf

Model	Kind of lever	Standard	Maximum allowable	Remarks
HW65AH	Boom lever	1.4 or below	1.9	
	Arm lever	1.4 or below	1.9	
	Bucket lever	1.4 or below	1.9	
	Swing lever	1.4 or below	1.9	

10) CONTROL LEVER STROKE

(1) Measure each lever stroke at the lever top using a ruler.

※ When the lever has play, take a half of this value and add it to the measured stroke.

(2) Preparation

Keep the hydraulic oil temperature at $50 \pm 5^\circ\text{C}$.

(3) Measurement

- ① Stop the engine.
- ② Measure each lever stroke at the lever top from neutral to the stroke end using a ruler.
- ③ Repeat step ② three times and calculate the average values.

(4) Evaluation

The measured drift should be within the following specifications.

Unit : mm

Model	Kind of lever	Standard	Maximum allowable	Remarks
HW65AH	Boom lever	82 ± 10	103	
	Arm lever	82 ± 10	103	
	Bucket lever	82 ± 10	103	
	Swing lever	82 ± 10	103	

11) PILOT PRIMARY PRESSURE

(1) Preparation

- ① Stop the engine.
- ② Push the pressure release button to bleed air.
- ③ Loosen and remove plug on the pilot pump delivery port (A4) and connect pressure gauge.
- ④ Start the engine and check for oil leakage from the port.
- ⑤ Keep the hydraulic oil temperature at $50 \pm 5^{\circ}\text{C}$.

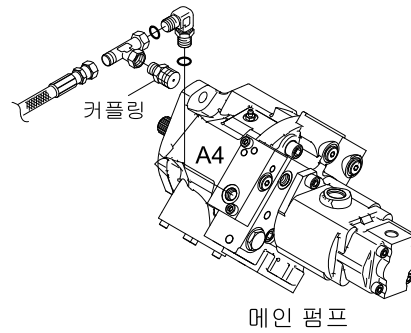

(2) Measurement

- ① Measure the primary pilot pressure at rated rpm.

HW60A6MA14

(3) Evaluation

The average measured pressure should meet the following specifications:

Unit : kgf / cm²

Model	Standard	Remark
HW65AH	30 ± 5	

12) FOR TRAVEL SPEED SELECTING PRESSURE:

(1) Preparation

- ① Stop the engine.
- ② Push the pressure release button to bleed air.
- ③ To measure the speed selecting pressure: Install a connector and pressure gauge assembly to turning joint D, E port as shown.
- ④ Start the engine and check for on leakage from the adapter.
- ⑤ Keep the hydraulic oil temperature at $50 \pm 5^\circ\text{C}$.

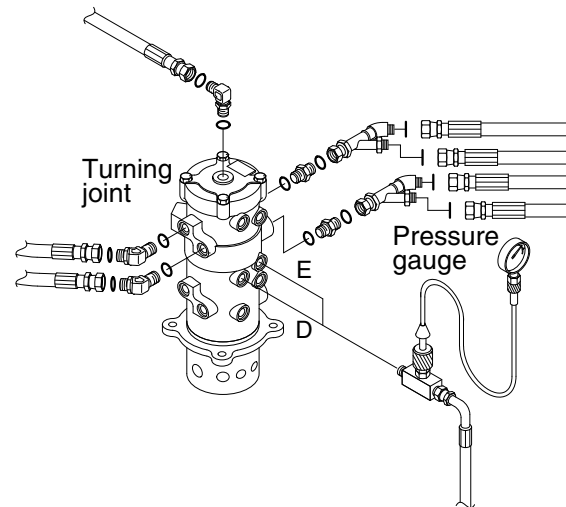

55W76MS15

(2) Measurement

- ① Lower the bucket and dozer blade to the ground to raise the tires off the ground.
- ② Select the following switch positions.
Parking switch : OFF
- ③ Measure the travel speed selecting pressure in the Hi or Lo position.
- ④ Operate the travel speed switch turns to the high or low position and measure the port D (high) or E (low) pressure.
- ⑤ Repeat steps ③ three times and calculate the average values.

(3) Evaluation

The average measured pressure should be within the following specifications.

Unit : kgf / cm²

Model	Travel speed mode	Standard		Maximum allowable	Remarks
		D port	E port		
HW65AH	Low speed	-	30 ± 5	-	
	High speed	30 ± 5	-	-	

13) SWING PARKING BRAKE RELEASING PRESSURE

(1) Preparation

- ① Stop the engine.
- ② Push the pressure release button to bleed air.
- ③ Install a connector and pressure gauge assembly to swing motor SH port, as shown.
- ④ Start the engine and check for oil leakage from the adapter.
- ⑤ Keep the hydraulic oil temperature at $50 \pm 5^\circ\text{C}$.

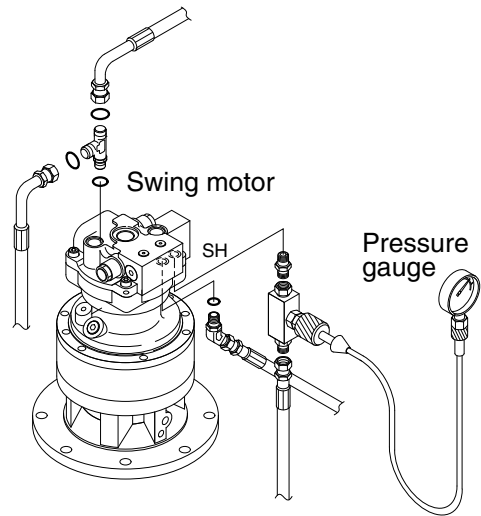

55W76MS16

(2) Measurement

- ① Operate the swing function or arm roll in function and measure the swing brake control pressure with the brake disengaged. Release the control lever to return to neutral and measure the control pressure when the brake is applied.
- ② Repeat three times and calculate the average values.

(3) Evaluation

The average measured pressure should be within the following specifications.

Unit : kgf / cm²

Model	Description	Standard	Remarks
HW65AH	Brake disengaged	30 ± 5	
	Brake applied	0	

14) MAIN PUMP DELIVERY PRESSURE

(1) Preparation

- ① Stop the engine.
- ② Push the pressure release button to bleed air.
- ③ To measure the main pump pressure.
Install a connector and pressure gauge assembly main pump gauge port (1G, 2G) as shown.
- ④ Start the engine and check for oil leakage from the port.
- ⑤ Keep the hydraulic oil temperature at $50 \pm 5^{\circ}\text{C}$.

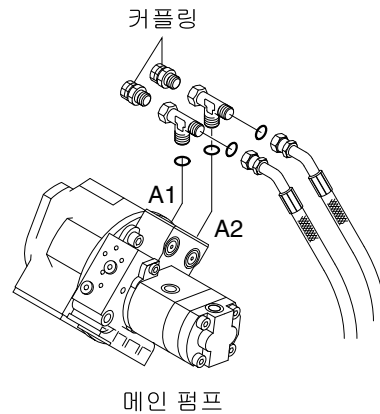

(2) Measurement

- ① Measure the main pump delivery pressure at high idle.

HW60A6MA17

(3) Evaluation

The average measured pressure should meet the following specifications.

Unit : kgf / cm^2

Model	Engine speed	Standard	Allowable limits	Remarks
HW65AH	High ilde	20 ± 5	-	

15) SYSTEM PRESSURE REGULATOR RELIEF SETTING

(1) Preparation

- ① Stop the engine.
- ② Push the pressure release button to bleed air.
- ③ To measure the system relief pressure. Install a connector and pressure gauge assembly main pump gauge port, as shown.
- ④ Start the engine and check for oil leakage from the port.
- ⑤ Keep the hydraulic oil temperature at $50 \pm 5^{\circ}\text{C}$.

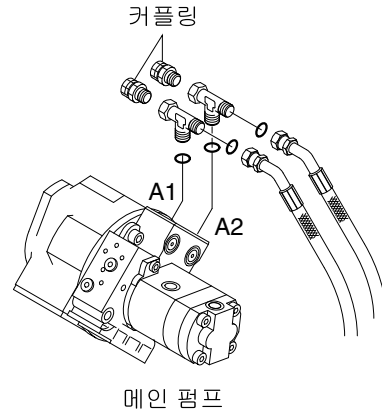

(2) Measurement

- ① Slowly operate each control lever of boom, arm and bucket functions at full stroke over relief and measure the pressure.
- ② In the swing function, place bucket against an immovable object and measure the relief pressure.
- ③ In the travel function, lock undercarriage with an immovable object and measure the relief pressure.

HW60A6MA17

(3) Evaluation

The average measured pressure should be within the following specifications.

Unit : kgf / cm²

Model	Function to be tested	Standard
HW65AH	Boom, Arm, Bucket	220 ± 10
	Travel	220 ± 10
	Swing	220 ± 10

GROUP 2 MAJOR COMPONENT

1. MAIN PUMP

Before inspection, wash the parts well and dry them completely.

Inspect the principal parts with care and replace them with new parts when any abnormal wear exceeding the allowable limit or damage considered harmful is found.

Replace the seal also when any remarkable deformation and damage are found.

1) PISTON ASSEMBLY AND CYLINDER BLOCK

- (1) Check the appearance visually.
No damage, scouring, abnormal wear (particularly, in the slide portion) should be found.
- (2) Check the clearance between the piston outside dia and cylinder block inside dia.
 $D-d \leq 0.050 \text{ mm}$

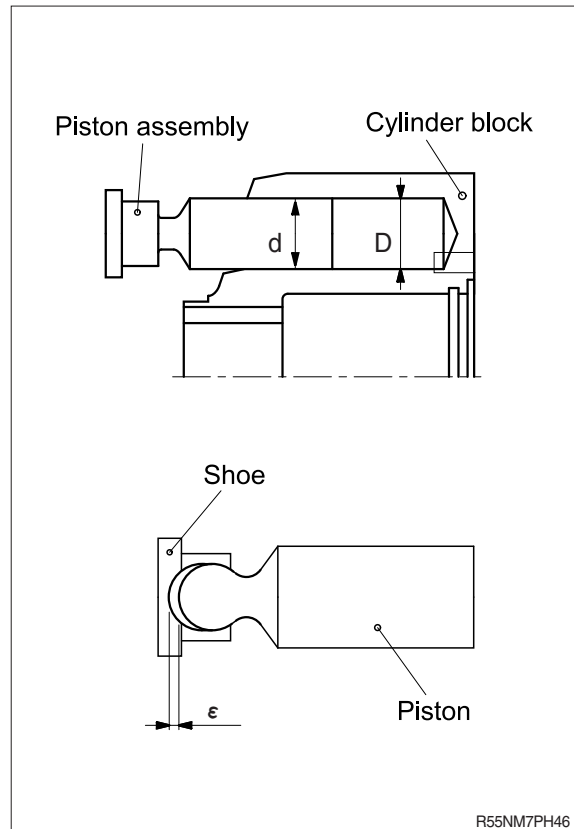

2) PISTON SHOE AND PISTON

- (1) Check the axial play of the piston and piston shoe.
 $\epsilon \leq 0.2 \text{ mm}$

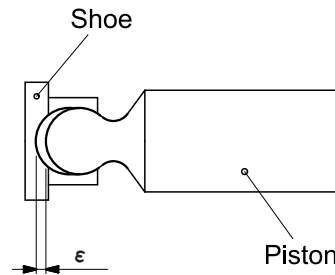

3) SHAFT

- (1) Check the wear amount of the oil seal mounting section.
Wear amount $\leq 0.025 \text{ mm}$

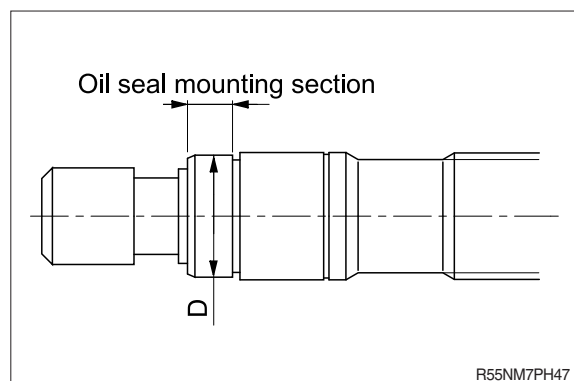

4) CONTROL PLATE

- (1) Check the slide surface for any damage.
When the damage is large, replace the plate with new one.

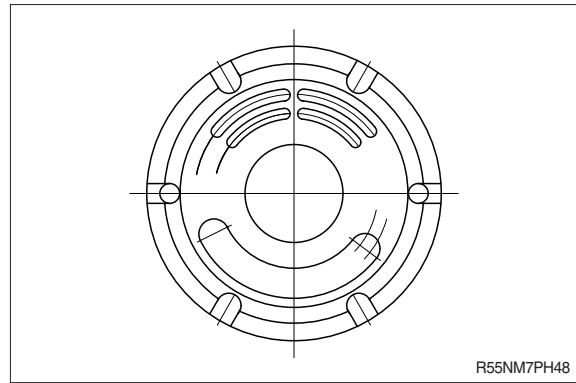

5) GUIDE AND RETAINER

- (1) Check for scouring or stepped wear.
If this can not be corrected, replace the guide and retainer with new full-set.
- (2) Fine scouring or damage can be corrected with lapping.
Carry out thorough washing after lapping.

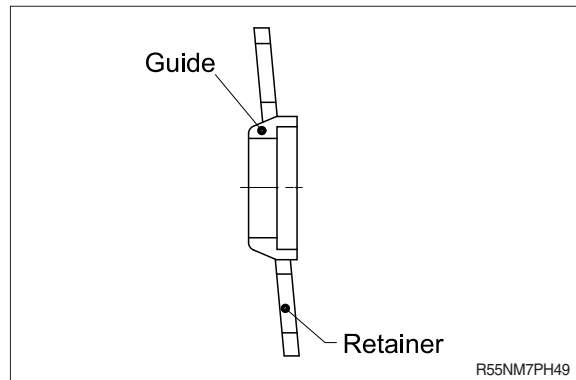

2. MAIN CONTROL VALVE

Part name	Inspection item	Criteria & measure
Block	<ul style="list-style-type: none"> Existence of scratch, rusting or corrosion. 	<ul style="list-style-type: none"> In case of damage in following section, replace part. <ul style="list-style-type: none"> Sliding sections of casing fore and spool, especially land sections applied with holded pressure. Seal pocket section where spool is inserted. Seal section of port where O-ring contacts. Seal section of each relief valve for main, travel, and port. Other damages that may damage normal functions.
Spool	<ul style="list-style-type: none"> Existence of scratch, gnawing, rusting or corrosion. O-ring seal sections at both ends. Insert spool in casing hole, rotate and reciprocate it. 	<ul style="list-style-type: none"> Replacement when its outside sliding section has scratch (Especially on seals-contacting section). Replacement when its sliding section has scratch. Correction or replacement when O-ring is damaged or when spool does not move smoothly.
Poppet	<ul style="list-style-type: none"> Damage of poppet or spring Insert poppet into casing and function it. 	<ul style="list-style-type: none"> Correction or replacement when sealing is incomplete. Normal when it can function lightly without being caught.
Around spring	<ul style="list-style-type: none"> Rusting, corrosion, deformation or breaking of spring, spring seat, plug or cover. 	<ul style="list-style-type: none"> Replacement for significant damage.
Around seal for spool	<ul style="list-style-type: none"> External oil leakage. Rusting, corrosion or deformation of seal plate. 	<ul style="list-style-type: none"> Correction or replacement. Correction or replacement.
Main relief valve & port relief valve	<ul style="list-style-type: none"> External rusting or damage. Contacting face of valve seat. Contacting face of poppet. Abnormal spring. O-rings, back up rings and seals. 	<ul style="list-style-type: none"> Replacement. Replacement when damaged. Replacement when damaged. Replacement. 100% replacement in general.

3. SWING DEVICE

1) WEARING PARTS

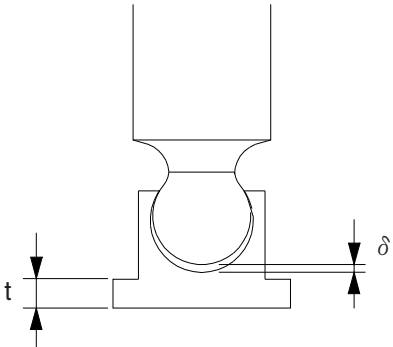
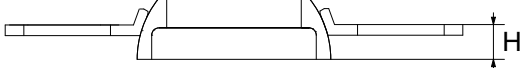
Inspection item	Standard dimension	Recommended replacement value	Counter measures
Clearance between piston and cylinder block bore	0.020	0.045	Replace piston or cylinder block
Play between piston and shoe caulking section (δ)	0	0.3	Replace assembly of piston and shoe
Thickness of shoe (t)	4	3.8	Replace assembly of piston and shoe
Combined height of set plate and guide (H)	17.4	17	Replace set of set plate and guide
Thickness of friction plate	3.6	3.2	Replace
			

2) SLIDING PARTS

Part name	Standard roughness	Remark
Shoe	0.8S	
Shoe plate	0.8S	
Cylinder	0.8S	
Valve plate	0.8S	

4. TRAVEL MOTOR

- 1) Free of corrosion, erosion or fretting; no damage to splines or keyways.

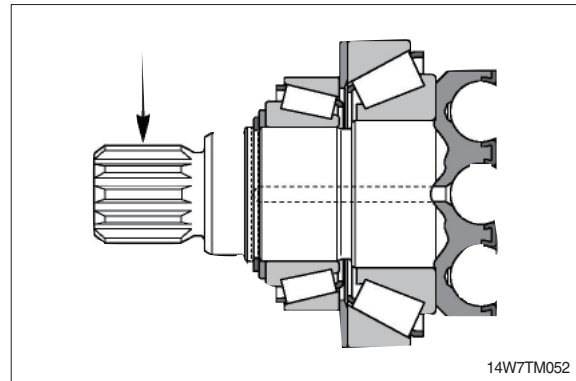

2) Pistons

- No scoring and no pittings.

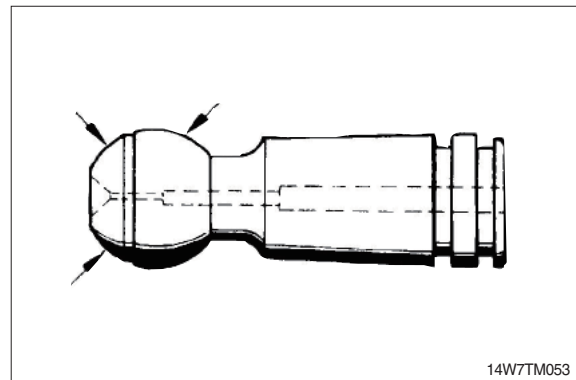

3) Center pin

- No scoring and no pittings.

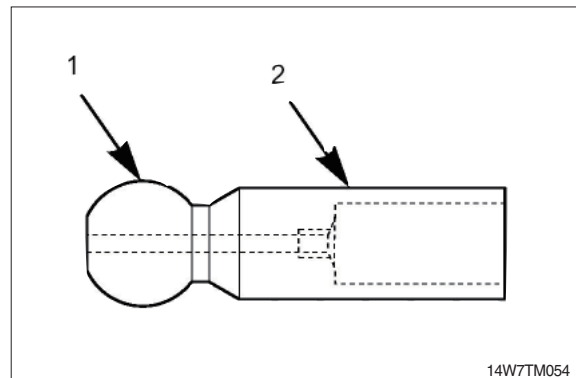

4) Retaining plate

- No scoring and no evidence of wear.

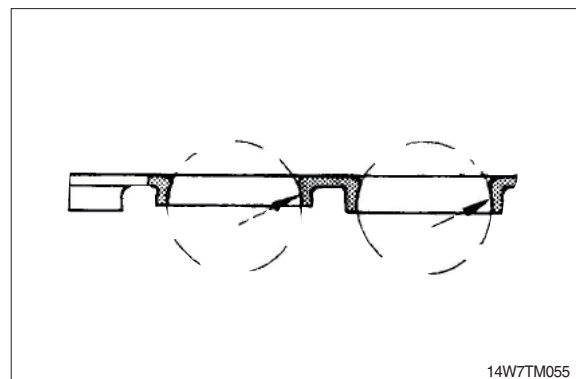

5) Cylinder block/control lens

- ① Bores free of scoring, no evidence of wear.
- ② Faces smooth and even, free of cracks and scoring.

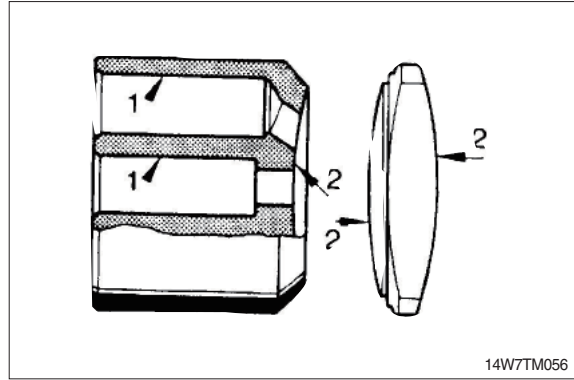

6) Control housing

Sliding surface and side guides free of scoring and no wear.

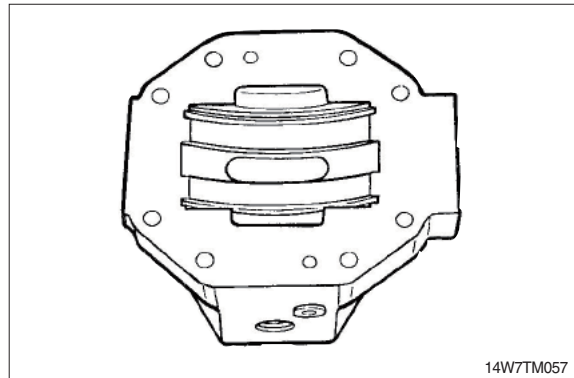

7) Visual check

Bearing areas free of scoring and no evidence of wear.

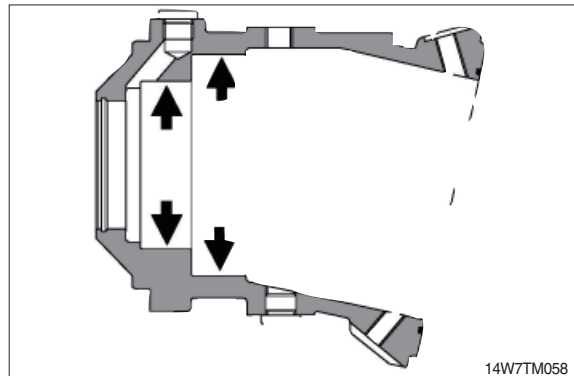

5. RCV LEVER

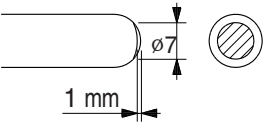
Maintenance check item	Criteria	Remark
Leakage	The valve is to be replaced when the leakage becomes more than 1000 cc/m at neutral handle position, or more than 2000 cc/m during operation.	Conditions : Primary pressure : 30 kgf/cm ² Oil viscosity : 23 cSt
Spool	This is to be replaced when the sliding surface has worn more than 10 μ m, compared with the non-sliding surface.	The leakage at the left condition is estimated to be nearly equal to the above leakage.
Push rod	 <p>This is to be replaced when the top end has worn more than 1mm.</p>	
Play at operating section	The pin, shaft, and joint of the operating section are to be replaced when their plays become more than 2 mm due to wears or so on.	When a play is due to looseness of a tightened section, adjust it.
Operation stability	When abnormal noises, hunting, primary pressure drop, etc. are generated during operation, and these cannot be remedied, referring to section 6 troubleshooting, replace the related parts.	

Notes 1. It is desirable to replace seal materials, such as O-rings, every disassembling. However, they may be reused, after being confirmed to be free of damage.

6. ACCELERATOR PEDAL

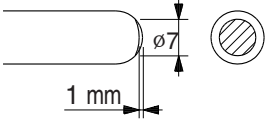
Maintenance check item	Criteria	Remark
Leakage	The valve is to be replaced when the leakage effect to the system. For example, the primary pressure drop.	Conditions : Primary pressure : 30 kgf/cm ² Oil viscosity : 23 cSt
Spool	This is to be replaced when the sliding surface has worn more than 10 μ m, compared with the non-sliding surface.	The leakage at the left condition is estimated to be nearly equal to the above leakage.
Push rod	 <p>This is to be replaced when the top end has worn more than 1mm.</p>	
Play at operating section	The pin, shaft, and joint of the operating section are to be replaced when their plays become more than 2mm due to wears or so on.	When a play is due to looseness of a tightened section, adjust it.
Operation stability	When abnormal noises, hunting, primary pressure drop, etc. are generated during operation, and these cannot be remedied, referring to section 6 troubleshooting, replace the related parts.	

Notes 1. It is desirable to replace seal materials, such as O-rings, every disassembling. However, they may be reused, after being confirmed to be free of damage.

7. TURNING JOINT

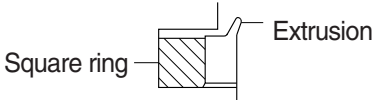
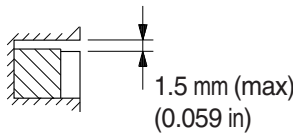
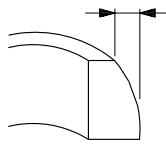
Part name		Maintenance standards	Remedy
Body, Stem	Sliding surface with sealing sections	Plating worn or peeled due to seizure or contamination	Replace
	Sliding surface between body and stem other than sealing section	· Worn abnormality or damaged more than 0.1 mm (0.0039 in) in depth due to seizure contamination	Replace
		· Damaged more than 0.1 mm (0.0039 in) in depth	Smooth with oilstone
	Sliding surface with thrust plate	· Worn more than 0.5 mm (0.02 in) or abnormality	Replace
		· Worn less than 0.5 mm (0.02 in)	Smooth
		· Damage due to seizure or contamination remediable within wear limit (0.5 mm) (0.02 in)	Smooth
Cover	Sliding surface with thrust plate	· Worn more than 0.5 mm (0.02 in) or abnormality	Replace
		· Worn less than 0.5 mm (0.02 in)	Smooth
		· Damage due to seizure or contamination remediable within wear limit (0.5 mm) (0.02 in)	Replace
Seal set	-	<ul style="list-style-type: none"> · Extruded excessively from seal groove square ring 	Replace
	-	<ul style="list-style-type: none"> · Slipper ring 1.5 mm (0.059 in) narrower than seal groove, or narrower than back ring 	Replace
	-	<ul style="list-style-type: none"> · Worn more than 0.5 mm (0.02 in) ~ 1.5 mm (MAX) (0.059 in) 	Replace

8. CYLINDER

Part name	Inspecting section	Inspection item	Remedy
Piston rod	• Neck of rod pin	• Presence of crack	• Replace
	• Weld on rod hub	• Presence of crack	• Replace
	• Stepped part to which piston is attached	• Presence of crack	• Replace
	• Threads	• Presence of crack	• Recondition or replace
	• Plated surface	• Plating is not worn off to base metal Rust is not present on plating Scratches are not present	• Replace or replate • Replace or replate • Recondition, replate or replace
	• Rod	• Wear of O.D.	• Recondition, replate or replace
Cylinder tube	• Bushing at mounting part	• Wear of I.D.	• Replace
	• Weld on bottom	• Presence of crack	• Replace
	• Weld on head	• Presence of crack	• Replace
	• Weld on hub	• Presence of crack	• Replace
	• Tube interior	• Presence of faults	• Replace if oil leak is seen
	• Bushing at mounting part	• Wear on inner surface	• Replace
Gland	• Bushing	• Flaw on inner surface	• Replace if flaw is deeper than coating

9. WORK EQUIPMENT

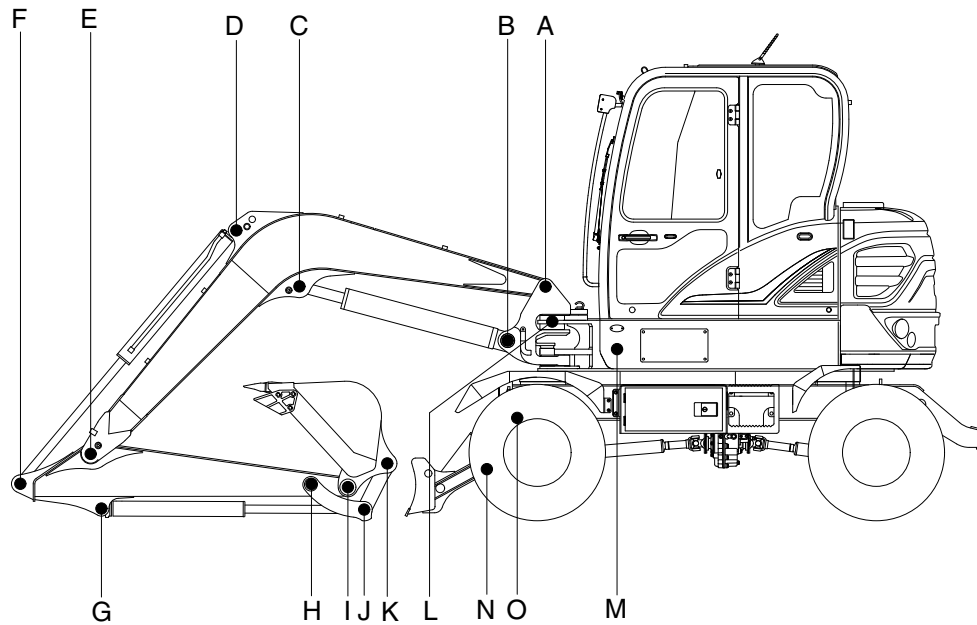

HW606MS30

Unit : mm

Mark	Measuring point (pin and bushing)	Normal value	Pin		Bushing		Remedy & Remark
			Recomm. service limit	Limit of use	Recomm. service limit	Limit of use	
A	Boom Rear	55	54	53.5	55.5	56	Replace
B	Boom Cylinder Head	60	59	58.5	60.5	61	"
C	Boom Cylinder Rod	60	59	58.5	60.5	61	"
D	Arm Cylinder Head	50	49	48.5	50.5	51	"
E	Boom Front	50	49	48.5	50.5	51	"
F	Arm Cylinder Rod	50	49	48.5	50.5	51	"
G	Bucket Cylinder Head	45	44	43.5	45.5	46	"
H	Arm Link	45	44	43.5	45.5	46	"
I	Bucket and Arm Link	45	44	43.5	45.5	46	"
J	Bucket Cylinder Rod	45	44	43.5	45.5	46	"
K	Bucket Link	45	44	43.5	45.5	46	"
L	Boom swing post	110	109	108.5	110.5	111	"
M	Boom swing cylinder	50	49	48.5	50.5	51	"
N	Blade cylinder	55	54	53.5	55.5	56	"
O	Blade and frame link	35	34	33.5	35.5	36	"