

## SECTION 3 HYDRAULIC SYSTEM

Group 1 Hydraulic Circuit .....	3-1
Group 2 Main Circuit .....	3-4
Group 3 Pilot Circuit .....	3-7
Group 4 Single Operation .....	3-12
Group 5 Combined Operation .....	3-27

# GROUP 1 HYDRAULIC CIRCUIT

## 1. HYDRAULIC CIRCUIT (1/3)

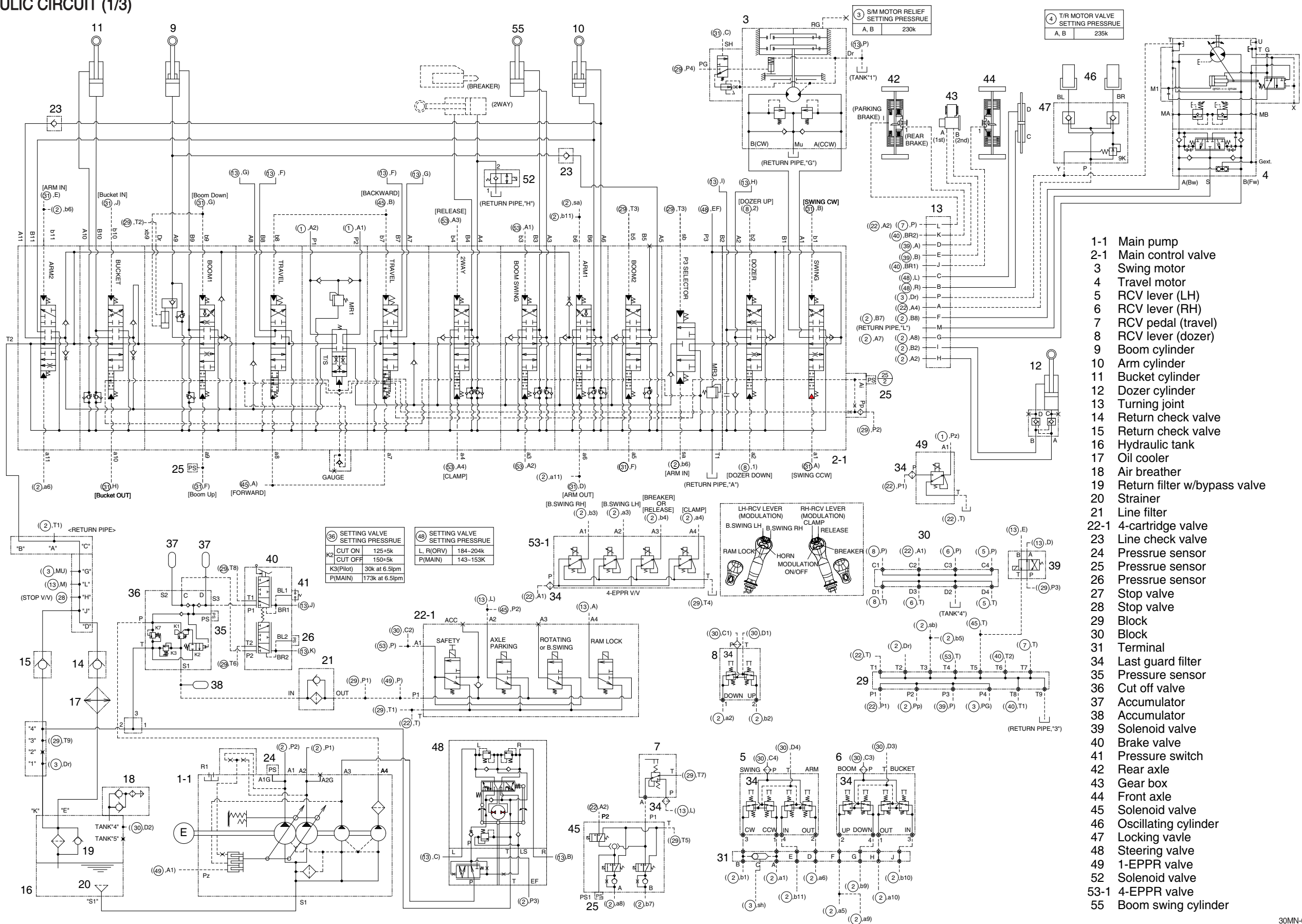

- 1-1 Main pump
- 2-1 Main control valve
- 3 Swing motor
- 4 Travel motor
- 5 RCV lever (LH)
- 6 RCV lever (RH)
- 7 RCV pedal (travel)
- 8 RCV lever (dozer)
- 9 Boom cylinder
- 10 Arm cylinder
- 11 Bucket cylinder
- 12 Dozer cylinder
- 13 Turning joint
- 14 Return check valve
- 15 Return check valve
- 16 Hydraulic tank
- 17 Oil cooler
- 18 Air breather
- 19 Return filter w/bypass valve
- 20 Strainer
- 21 Line filter
- 22-1 4-cartridge valve
- 23 Line check valve
- 24 Pressure sensor
- 25 Pressure sensor
- 26 Pressure sensor
- 27 Stop valve
- 28 Stop valve
- 29 Block
- 30 Block
- 31 Terminal
- 34 Last guard filter
- 35 Pressure sensor
- 36 Cut off valve
- 37 Accumulator
- 38 Accumulator
- 39 Solenoid valve
- 40 Brake valve
- 41 Pressure switch
- 42 Rear axle
- 43 Gear box
- 44 Front axle
- 45 Solenoid valve
- 46 Oscillating cylinder
- 47 Locking valve
- 48 Steering valve
- 49 1-EPPR valve
- 52 Solenoid valve
- 53-1 4-EPPR valve
- 55 Boom swing cylinder

## 2. HYDRAULIC CIRCUIT (2/3)

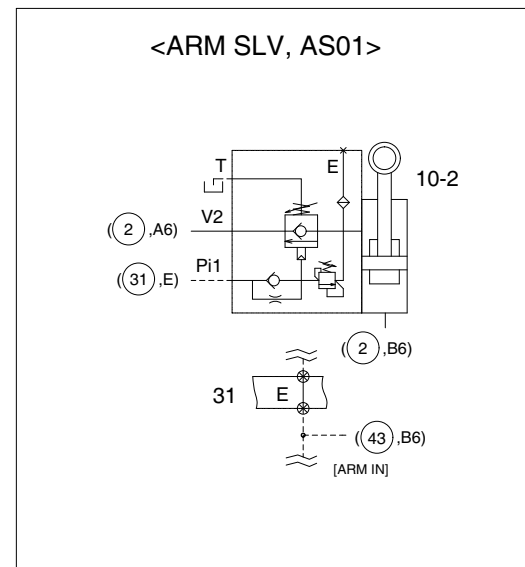
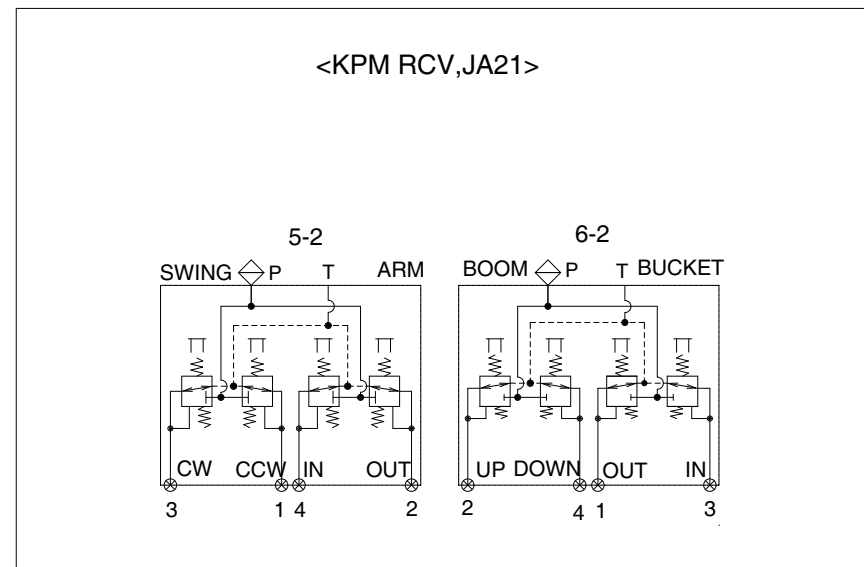
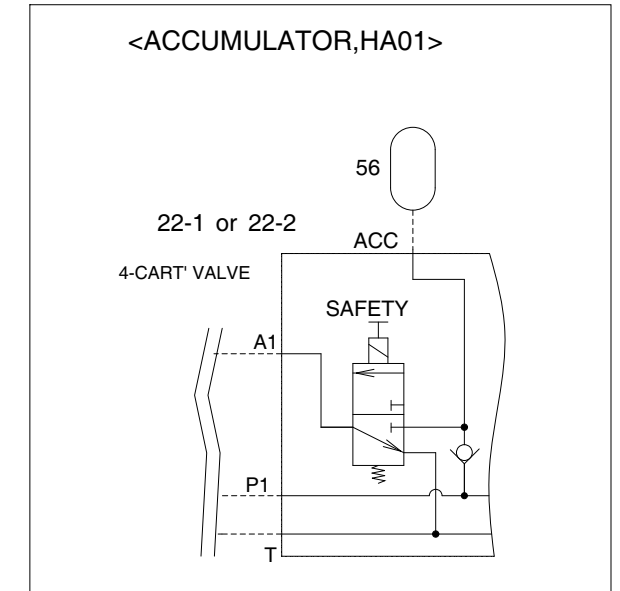
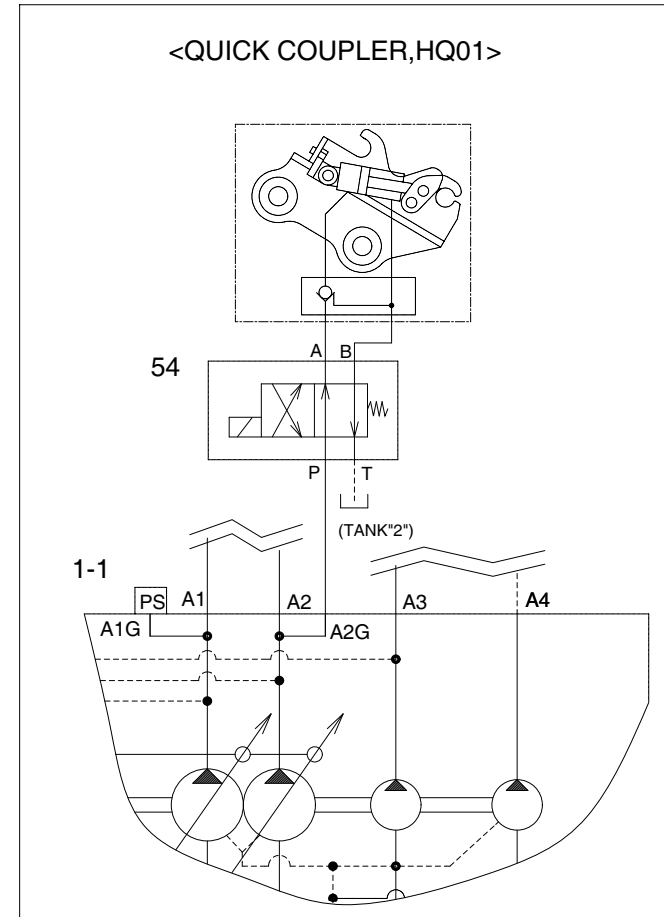
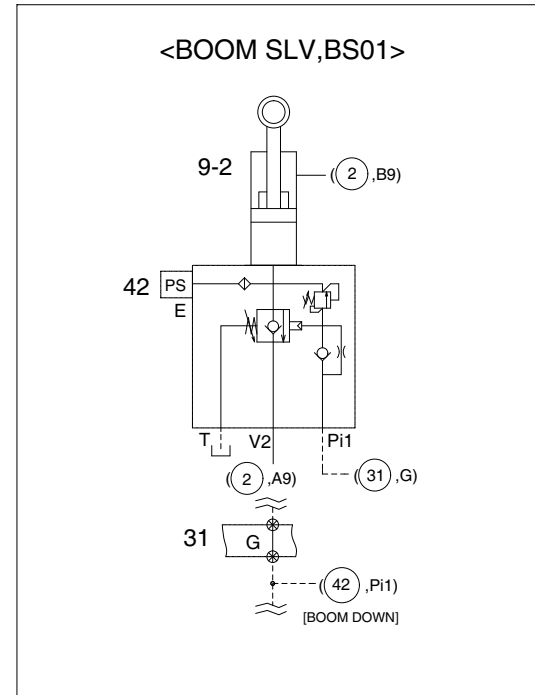
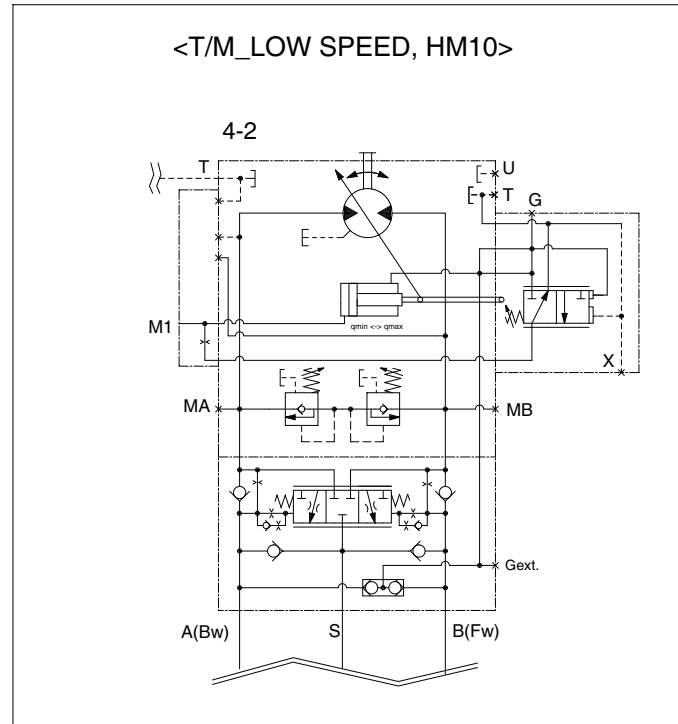

- 1-1 Main pump
- 4-2 Travel motor
- 5-2 RCV lever-LH
- 6-2 RCV lever-RH
- 9-2 Boom cylinder with SLV
- 10-2 Arm cylinder with SLV
- 54 Solenoid valve
- 56 Accumulator

### 3. HYDRAULIC CIRCUIT (3/3)

<ROTATING,HR02>

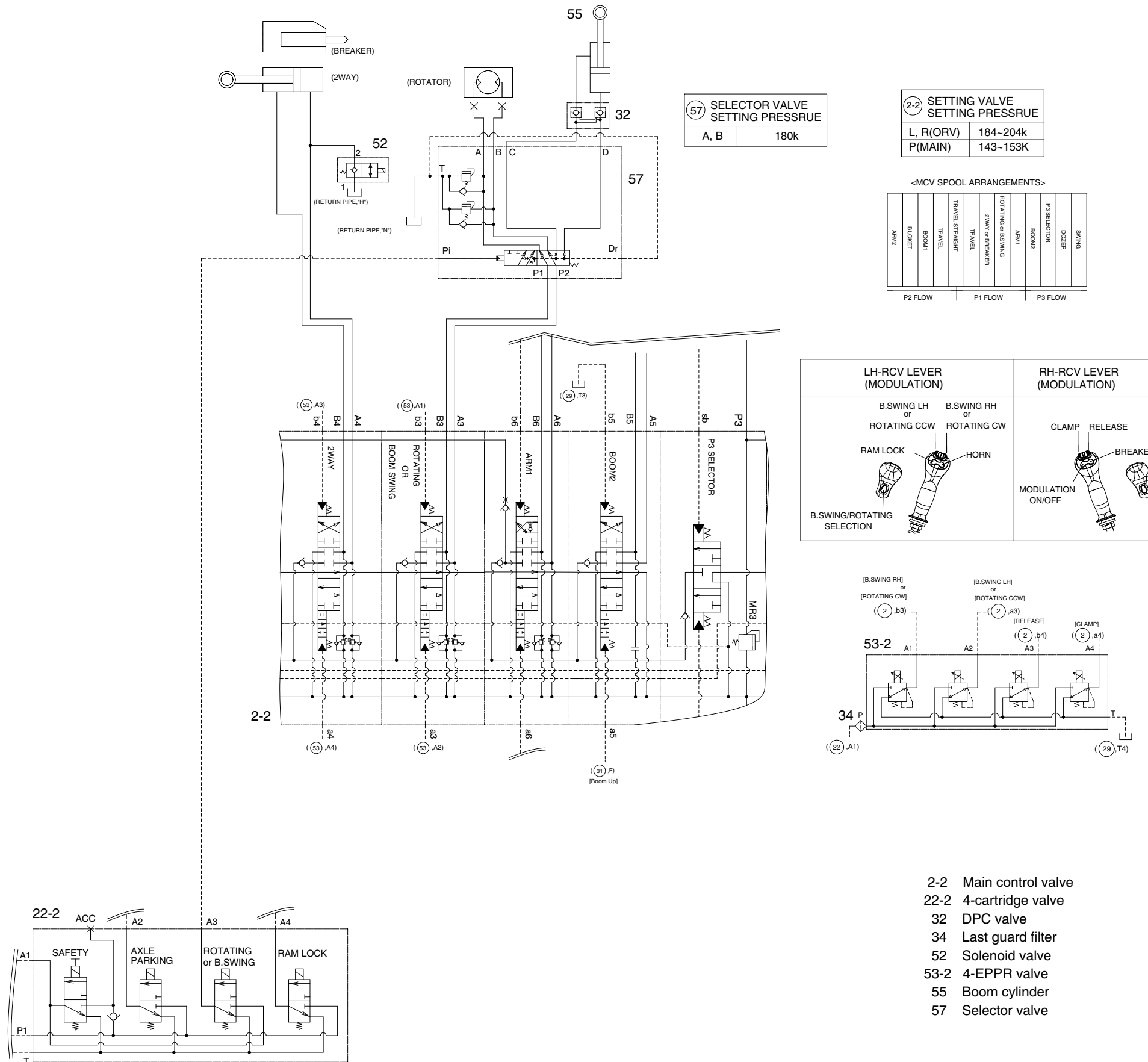

57 SELECTOR VALVE SETTING PRESSURE	
A, B	180k

2-2 SETTING VALVE SETTING PRESSURE	
L, R (ORV)	184-204k
P (MAIN)	143-153k

<MCV SPOOL ARRANGEMENTS>

ARM2	ARM1	BOOM2	BOOM1	TRAVEL STRAIGHT	TRAVEL	2WAY or BREAKER	ROTATING or B.SWING	P3 SELECTOR	DOZER	SWING
P2 FLOW			P1 FLOW				P3 FLOW			

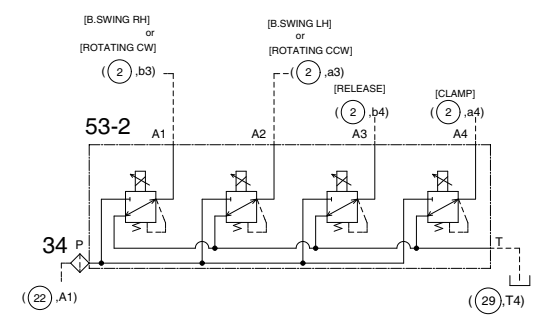
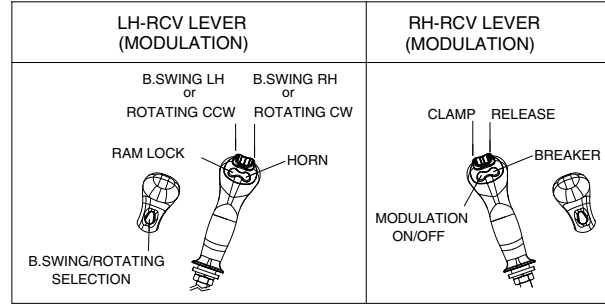

- 2-2 Main control valve
- 22-2 4-cartridge valve
- 32 DPC valve
- 34 Last guard filter
- 52 Solenoid valve
- 53-2 4-EPPR valve
- 55 Boom cylinder
- 57 Selector valve

## GROUP 2 MAIN CIRCUIT

The main hydraulic circuit consists of suction circuit, delivery circuit, return circuit and drain circuit.

The hydraulic system consists of one main pump, one control valve, one swing motor, four cylinders and two travel motors.

The swash plate type variable displacement axial piston pump is used as the main pump and is driven by the engine at ratio 1.0 of engine speed.

### 1. SUCTION AND DELIVERY CIRCUIT

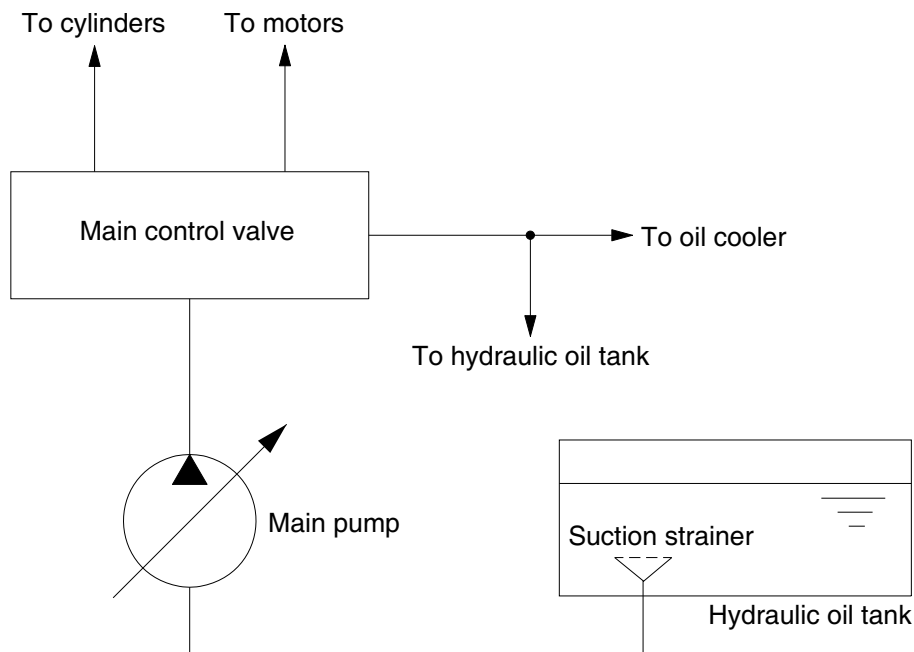

140L3CI01

The pumps receive oil from the hydraulic tank through a suction filter. The discharged oil from the pump flows into the control valve and goes out the tank ports.

The oil discharged from the main pump flows to the actuators through the control valve.

The control valve controls the hydraulic functions.

The return oil from the actuators flows to the hydraulic tank through the control valve and the oil cooler.

## 2. RETURN CIRCUIT

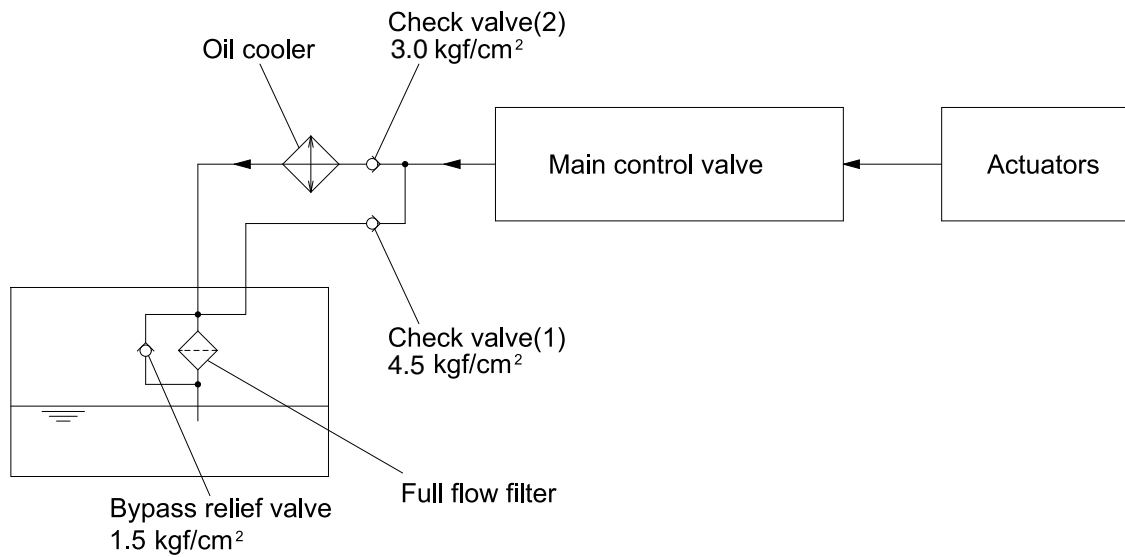

HW65AH3CI02

All oil returned from each actuator returns to the hydraulic tank through the control valve.

The bypass check valves are provided in the return circuit.

The setting pressure of bypass check valves are  $3.0 \text{ kgf/cm}^2$  (43 psi) and  $4.5 \text{ kgf/cm}^2$  (64 psi). Usually, oil returns to the hydraulic tank from the left side of control valve through oil cooler.

When oil temperature is low, viscosity becomes higher and flow resistance increases when passing through the oil cooler. When the oil pressure exceeds  $4.5 \text{ kgf/cm}^2$  (64 psi), the oil returns directly to the hydraulic tank, resulting in the oil temperature being raised quickly at an appropriate level.

When the oil cooler is clogged, the oil returns directly to the hydraulic tank through bypass check valve (1).

The full-flow filter and bypass relief valve are provided in the hydraulic tank.

The oil returned from right and left side of control valve is combined and filtered by the full-flow filter. A bypass relief valve is provided in the full-flow filter.

When the filter element is clogged, the bypass relief valve opens at  $1.5 \text{ kgf/cm}^2$  (21 psi) differential pressure.

### 3. DRAIN CIRCUIT

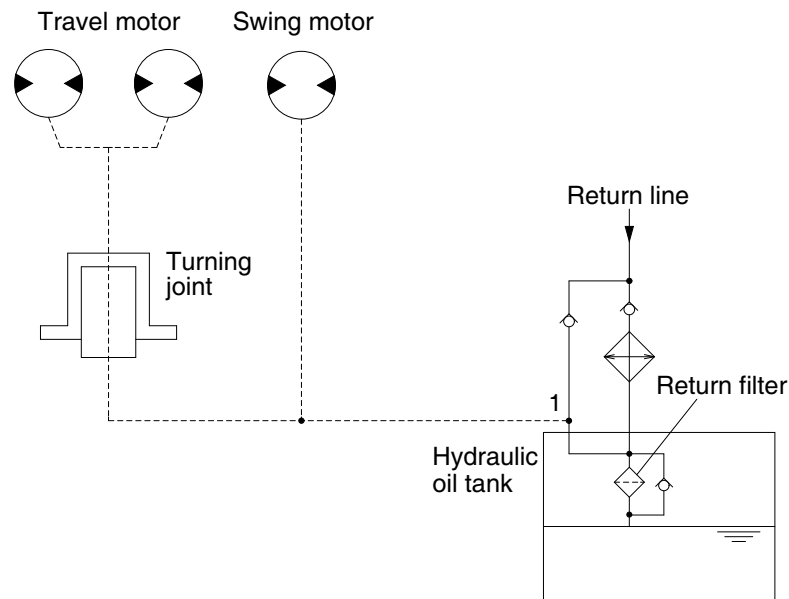

HW65AH3CI03

Besides internal leaks from the motors and main pump, the oil for lubrication circulates.

#### 1) TRAVEL MOTOR DRAIN CIRCUIT

Oil leaked from the right and left travel motors comes out of the drain ports provided in the respective motor casing and join with each other. These oils pass through the turning joint and return to the hydraulic tank after being filtered by return filter.

#### 2) SWING MOTOR DRAIN CIRCUIT

Oil leaked from the swing motor returns to the hydraulic tank passing through a return filter with oil drained from the travel circuit.

## GROUP 3 PILOT CIRCUIT

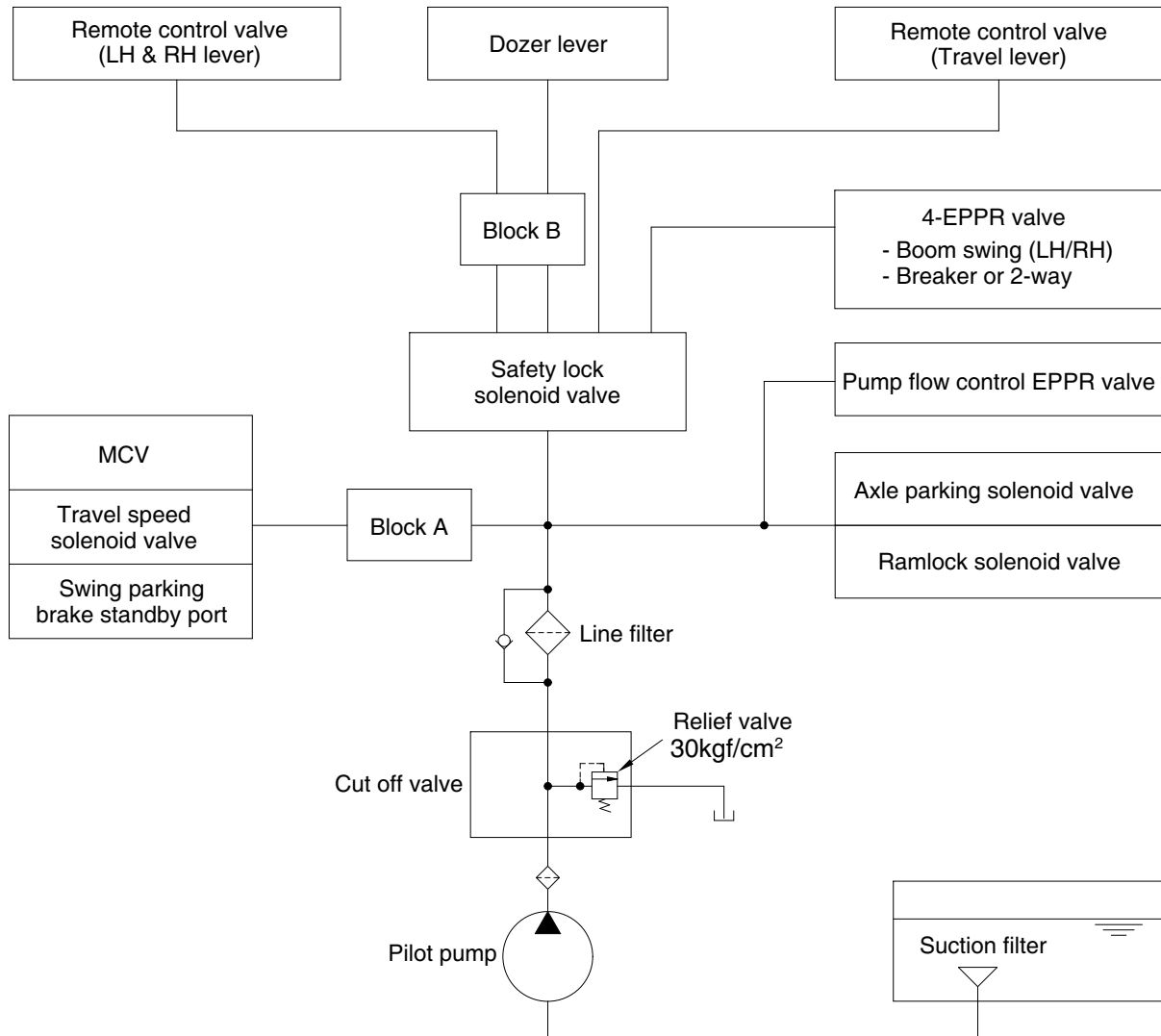

HW65AH3CI04

The pilot circuit consists of suction circuit, delivery circuit and return circuit.

The pilot pump receives the oil from the hydraulic tank through the suction filter.

The pilot pressure is controlled by the relief valve in the cut off valve.

The discharged oil from the pilot pump flows to the control valves, solenoid valves and EPPR valves through the cut off valve and line filter as below.

- RCV lever (LH & RH) and dozer lever through the safety lock solenoid valve and block B.
- RCV pedal (travel), forward/reverse travel solenoid valve and 4-EPPR valve (boom swing and breaker or 2-way) through the safety lock solenoid valve.
- Auto idle supply port of MCV, parking brake standby port of swing motor and travel speed solenoid valve through the block A.
- Axle parking solenoid valve, ram lock solenoid valve and pump flow control EPPR valve.



# 1. SUCTION, DELIVERY AND RETURN CIRCUIT

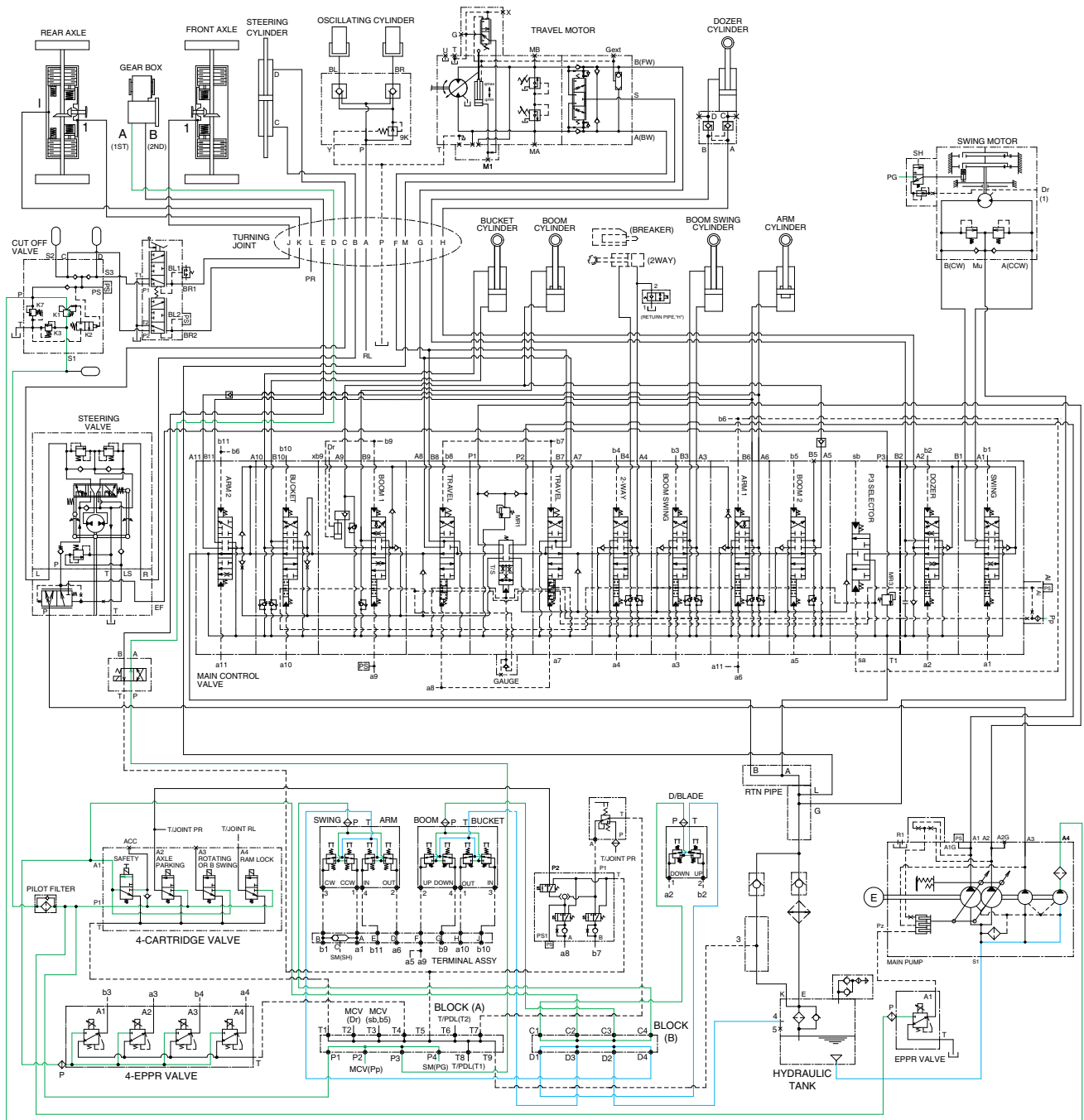

HW65AH3HC02

The pilot pump receives oil from the hydraulic tank. The discharged oil from the pilot pump flows to the safety solenoid valve through the line filter. The oil is filtered by the line filter. The oil filtered by line filter flows remote control valve through safety solenoid valve.

Also, the oil flows EPPR valves, solenoid valves and auto idle port of MCV.

The pilot relief valve is provided in the cut off valve for limiting the pilot circuit pressure.

The return oil flow into the hydraulic tank.

## 2. SAFETY VALVE (SAFETY LEVER)

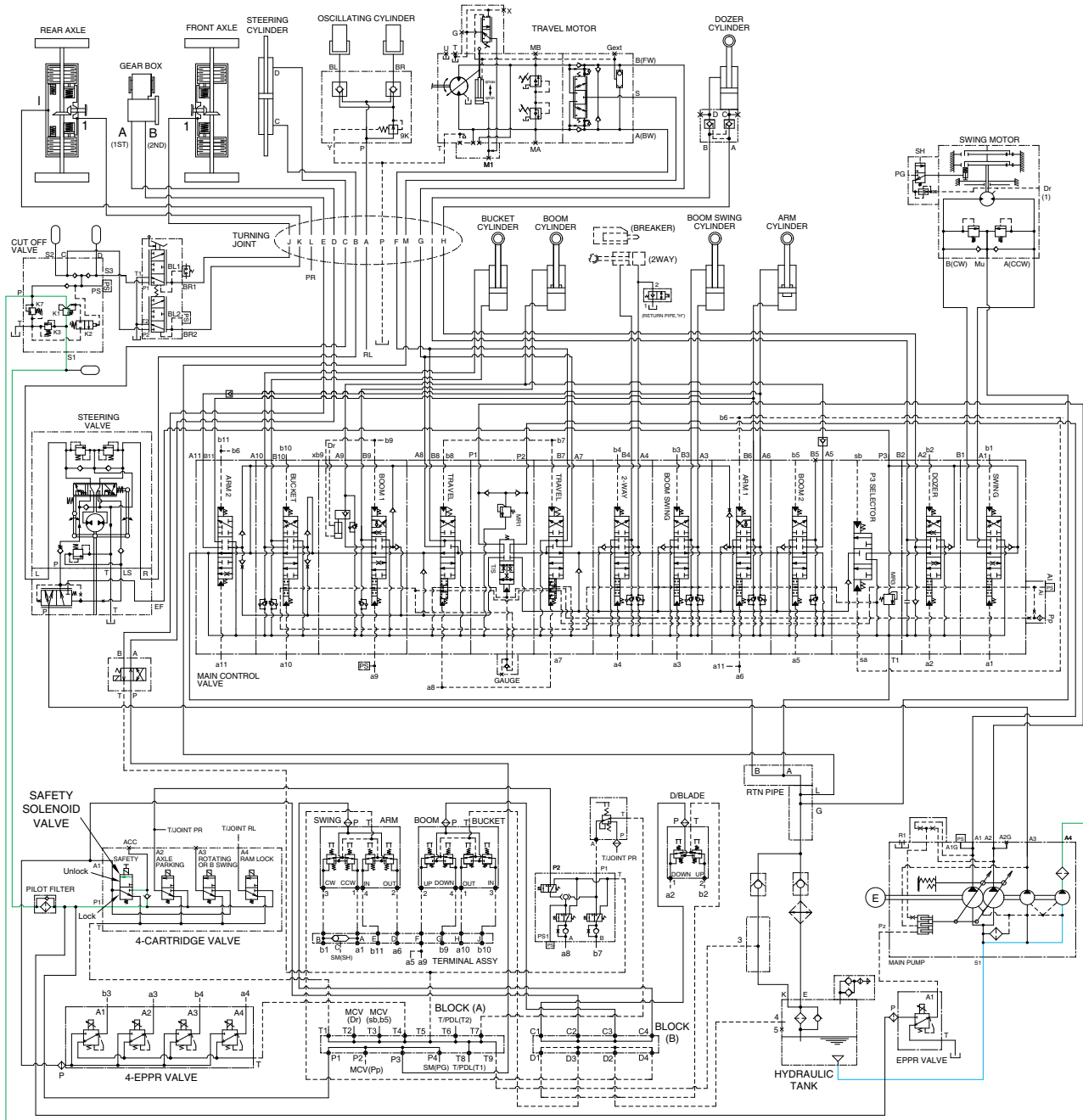

HW65AH3HC03

When the lever of the safety solenoid valve is in the unlock position, oil flows into the remote control valve through solenoid valve and line filter.

When the lever of the safety solenoid valve is in the lock position, oil does not flow into the remote control valve, because of the blocked port.

### 3. TRAVEL SPEED CONTROL SYSTEM

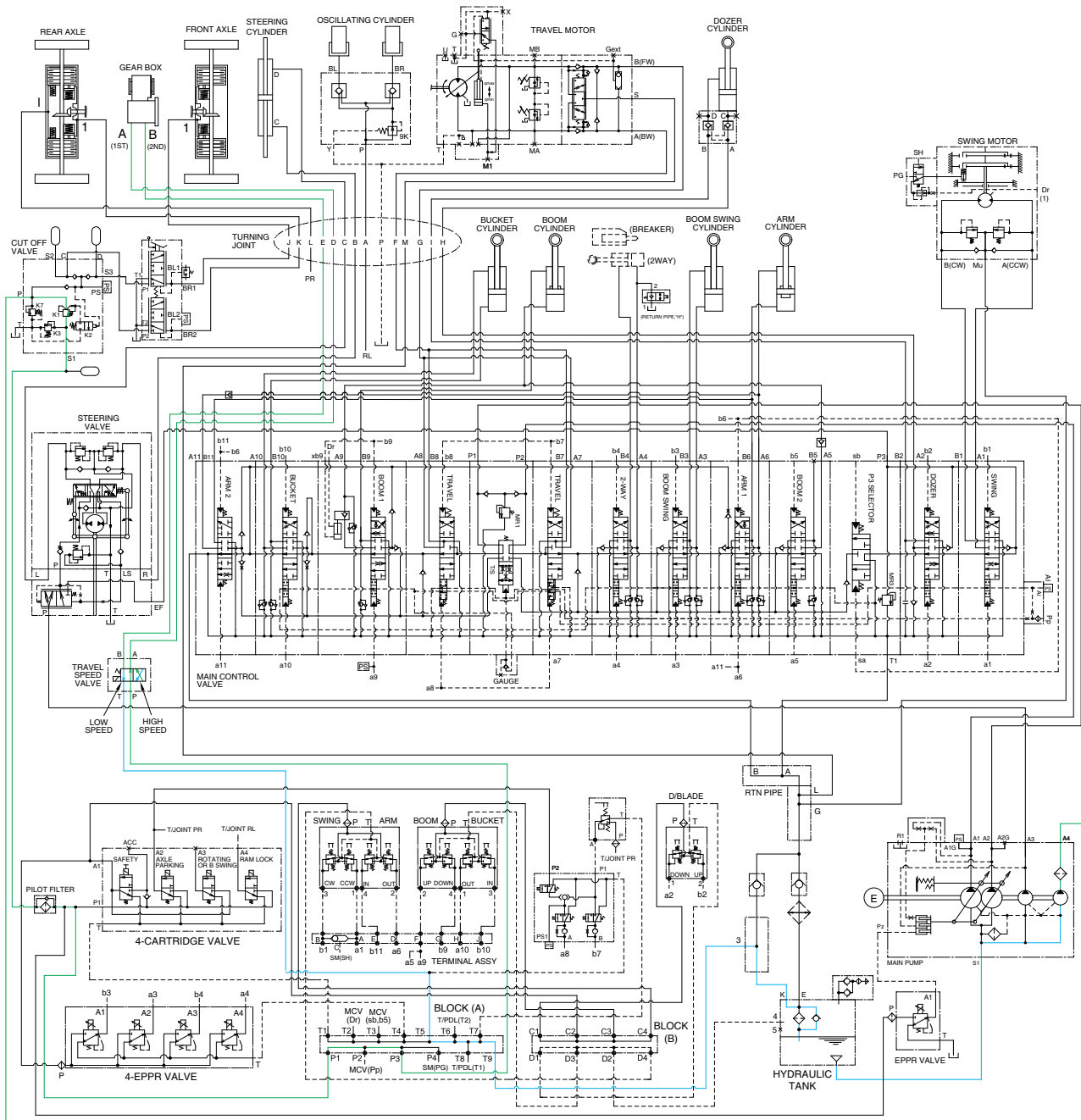

HW65AH3HC04

When the travel speed switch of the RH multifunction switch was placed in high or low position, the travel speed solenoid valve is changed to high or low speed position and thus the gear box is changed into high or low speed condition.

The pressure oil from pilot pump flows to the gear box through relief valve of cut off valve and the travel speed solenoid valve.

## 4. SWING PARKING BRAKE RELEASE

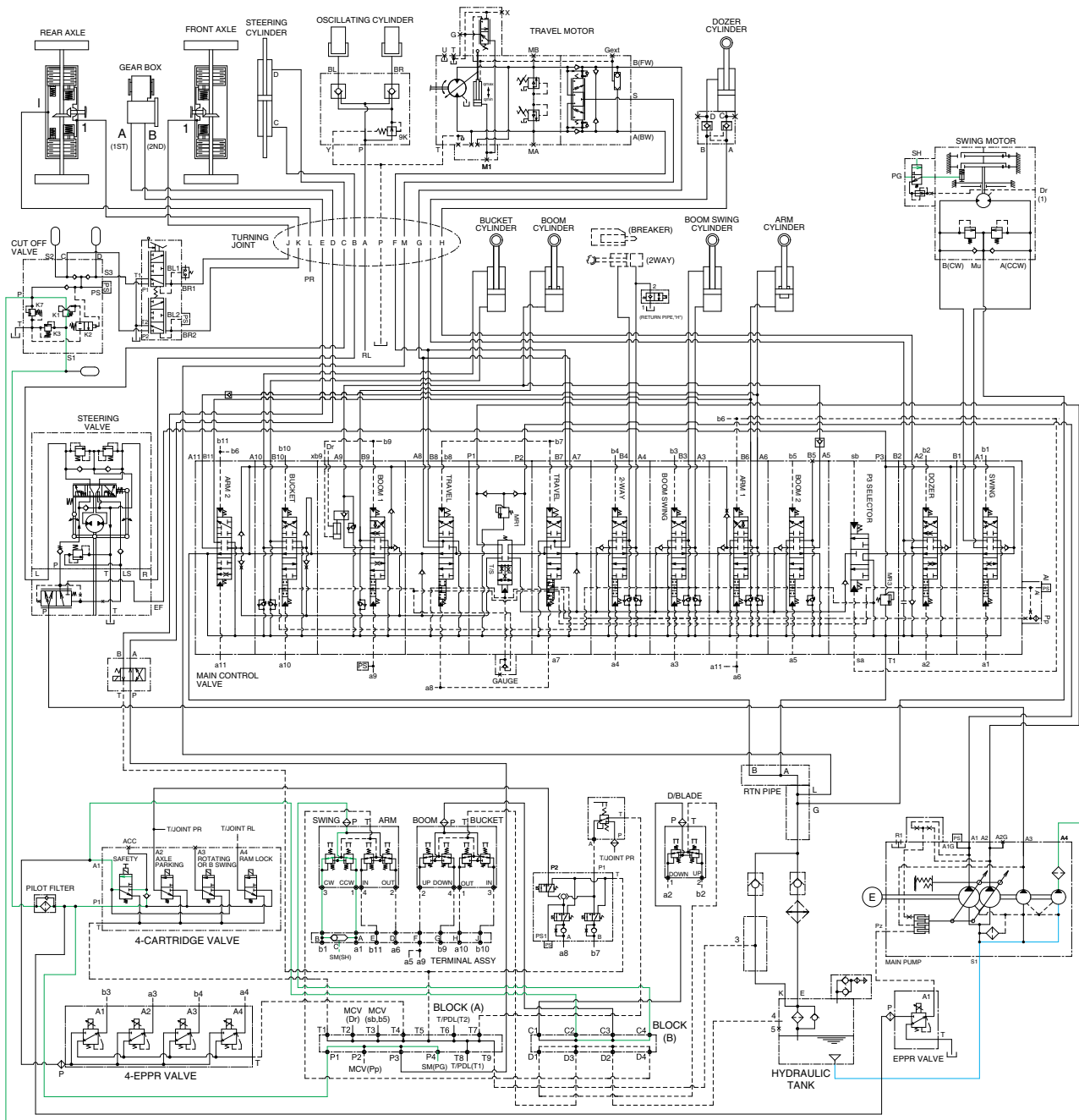

HW65AH3HC05

When the swing control lever is tilted, the pilot oil flow into SH port of shuttle valve, this pressure move spool so, discharged oil from pilot pump flow into PG port.

This pressure is applied to swing motor disc, thus the brake is released.

When the swing control lever is set in the neutral position, oil in the swing motor disc cylinder is drained, thus the brake is applied.

# GROUP 4 SINGLE OPERATION

## 1. BOOM UP OPERATION

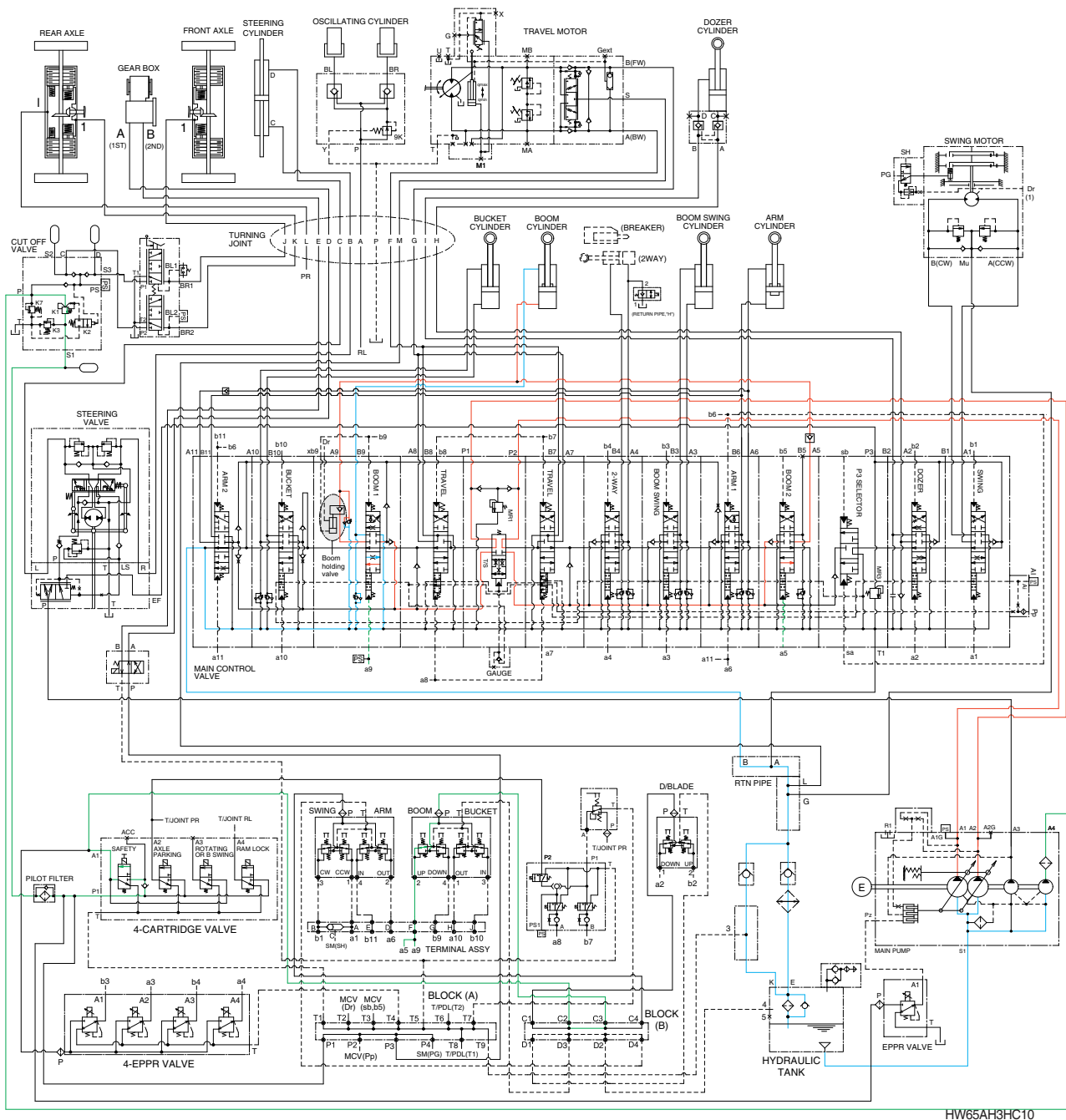

When the right control lever is pulled back, the boom spools in the main control valve are moved to the up position by the pilot oil pressure (a5, a9) from the remote control valve. The oil from the A1 and A2 pump flows into the main control valve and then goes to the large chamber of boom cylinder. At the same time, the oil from the small chamber of boom cylinder returns to the hydraulic oil tank through the boom 1 spool in the main control valve. When this happens, the boom goes up. The excessive pressure in the boom cylinder bottom end circuit is prevented by relief valve. When the boom is up and the control lever is returned to neutral position, the circuit for the holding pressure at the bottom end of the boom cylinder is closed by the boom holding valve. This prevents the hydraulic drift of boom cylinder.

## 2. BOOM DOWN OPERATION

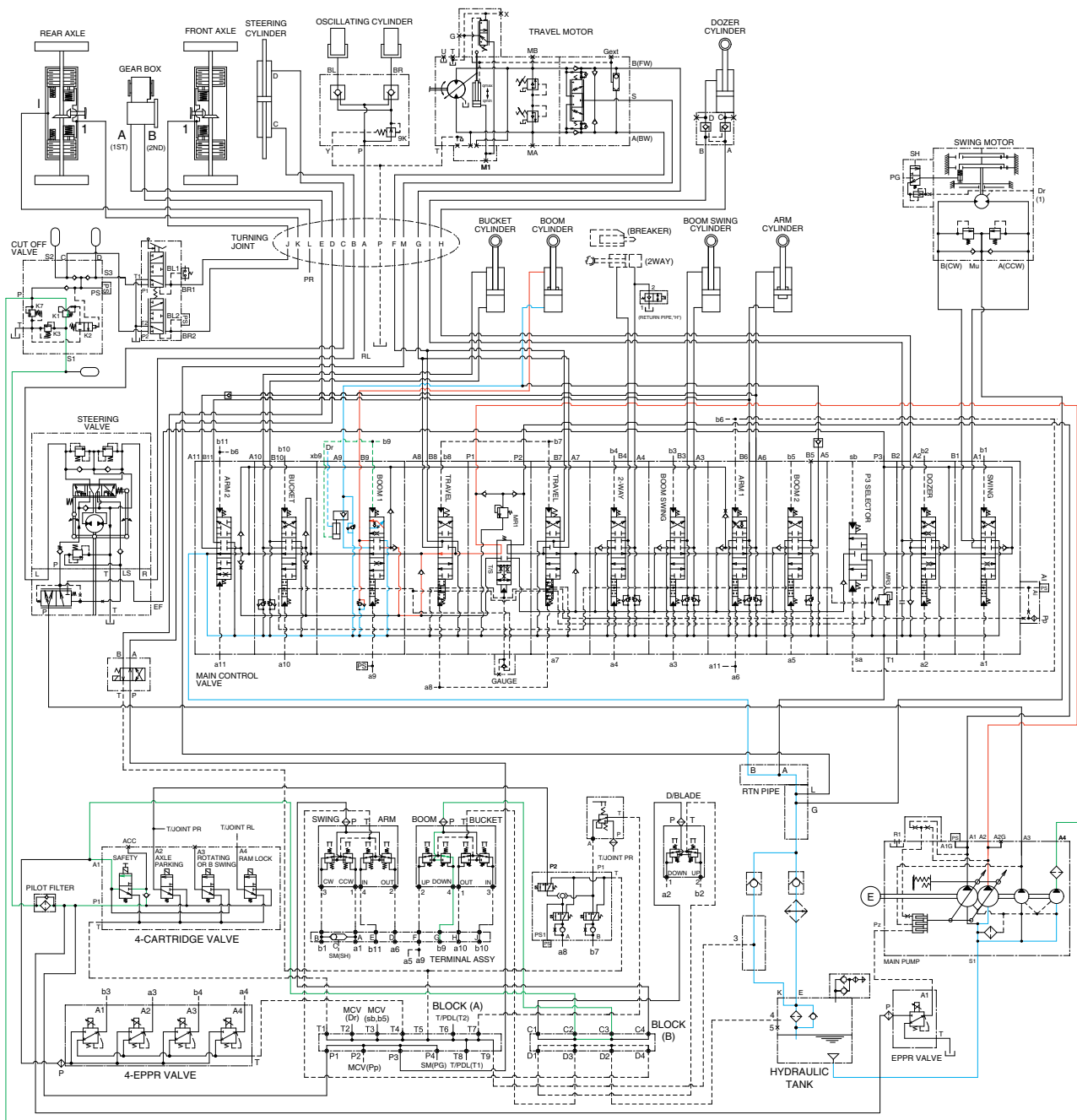

HW65AH3HC11

When the right control lever is pushed forward, the boom spool in the main control valve are moved to the down position by the pilot oil pressure (b9) from the remote control valve.

The oil from the A2 pump flows into the main control valve and then goes to the small chamber of boom cylinder. At the same time, the oil from the large chamber of boom cylinder returns to the hydraulic tank through the boom spool in the main control valve.

The excessive pressure in the boom cylinder rod end circuit is prevented by the relief valve.

### 3. ARM ROLL IN OPERATION

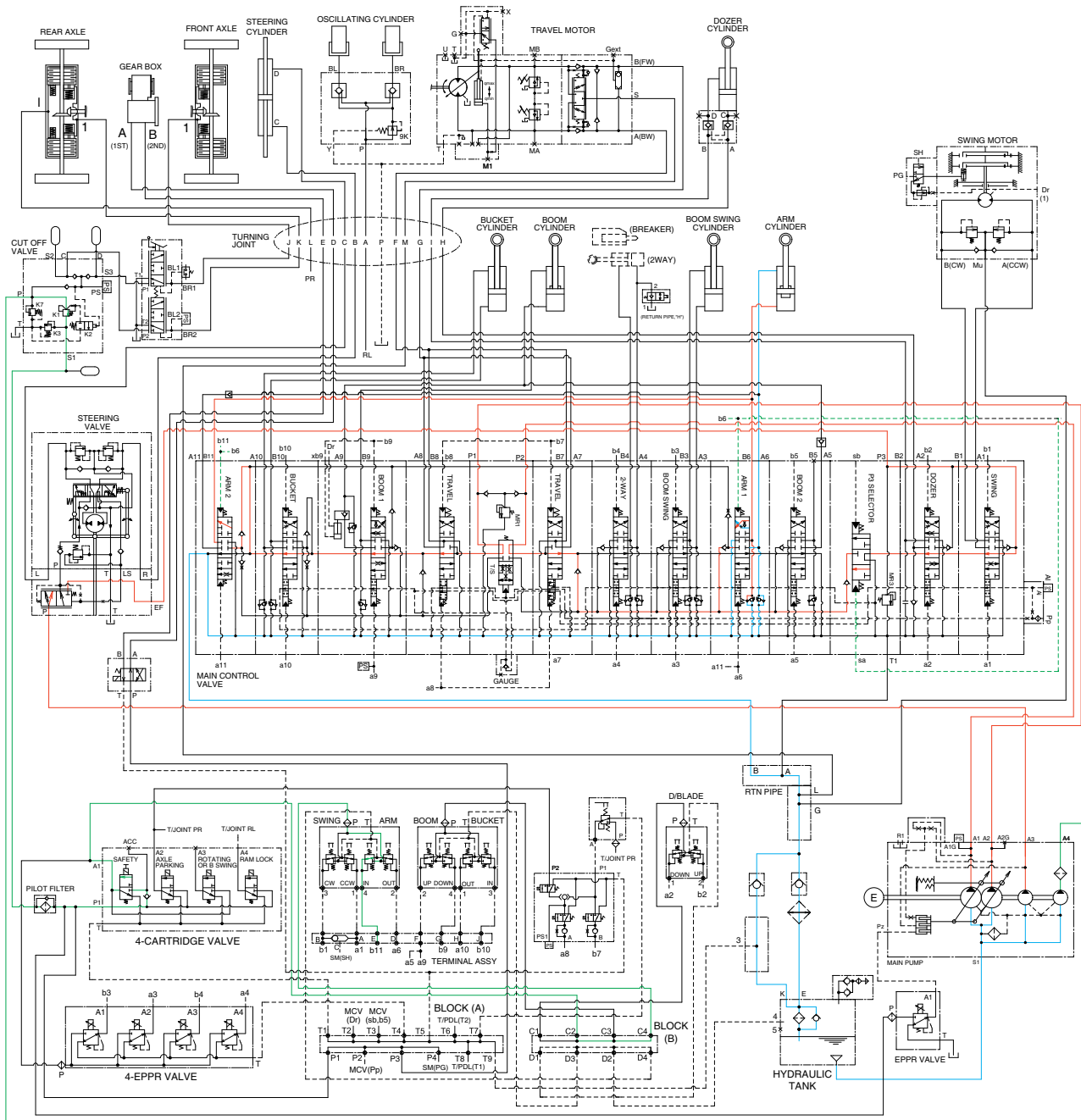

HW65AH3HC12

When the left control lever is pulled back, the arm spools in the main control valve are moved to the roll in position by the pilot oil pressure (b6, b11) from the remote control valve. Also, the pilot pressure (sa) flows to the P3 selector valve and it moves the up position. The oil from the A1, A2 and A3 pump flows into the main control valve and then goes to the large chamber of arm cylinder. At the same time, the oil from small chamber of arm cylinder returns to the hydraulic oil tank through the arm 1 spool in the main control valve. When this happens, the arm rolls in. The cavitation which will happen to the bottom of the arm cylinder is also prevented by the make-up valve in the main control valve.

## 4. ARM ROLL OUT OPERATION

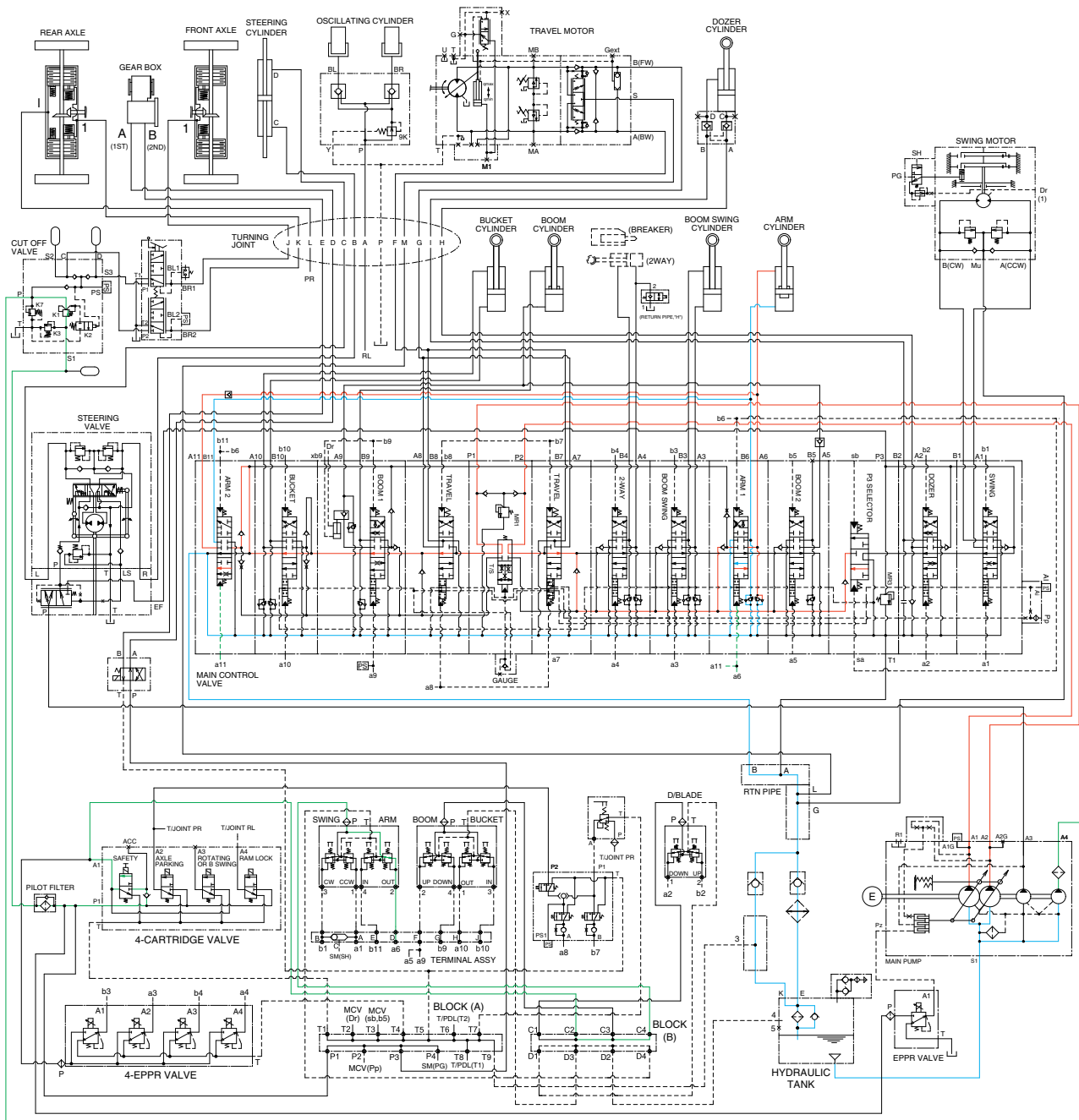

HW65AH3HC13

When the left control lever is pushed forward, the arm spools in the main control valve are moved to the roll out position by the pilot oil pressure (a6, a11) from the remote control valve.

The oil from the A1 and A2 pump flows into the main control valve and then goes to the small chamber of arm cylinder.

At the same time, the oil from the large chamber of arm cylinder returns to the hydraulic oil tank through the arm 1 spool in the main control valve. When this happens, the arm rolls out.

The cavitation which will happen to the rod of the arm cylinder is also prevented by the make-up valve in the main control valve.



## 5. BUCKET ROLL IN OPERATION

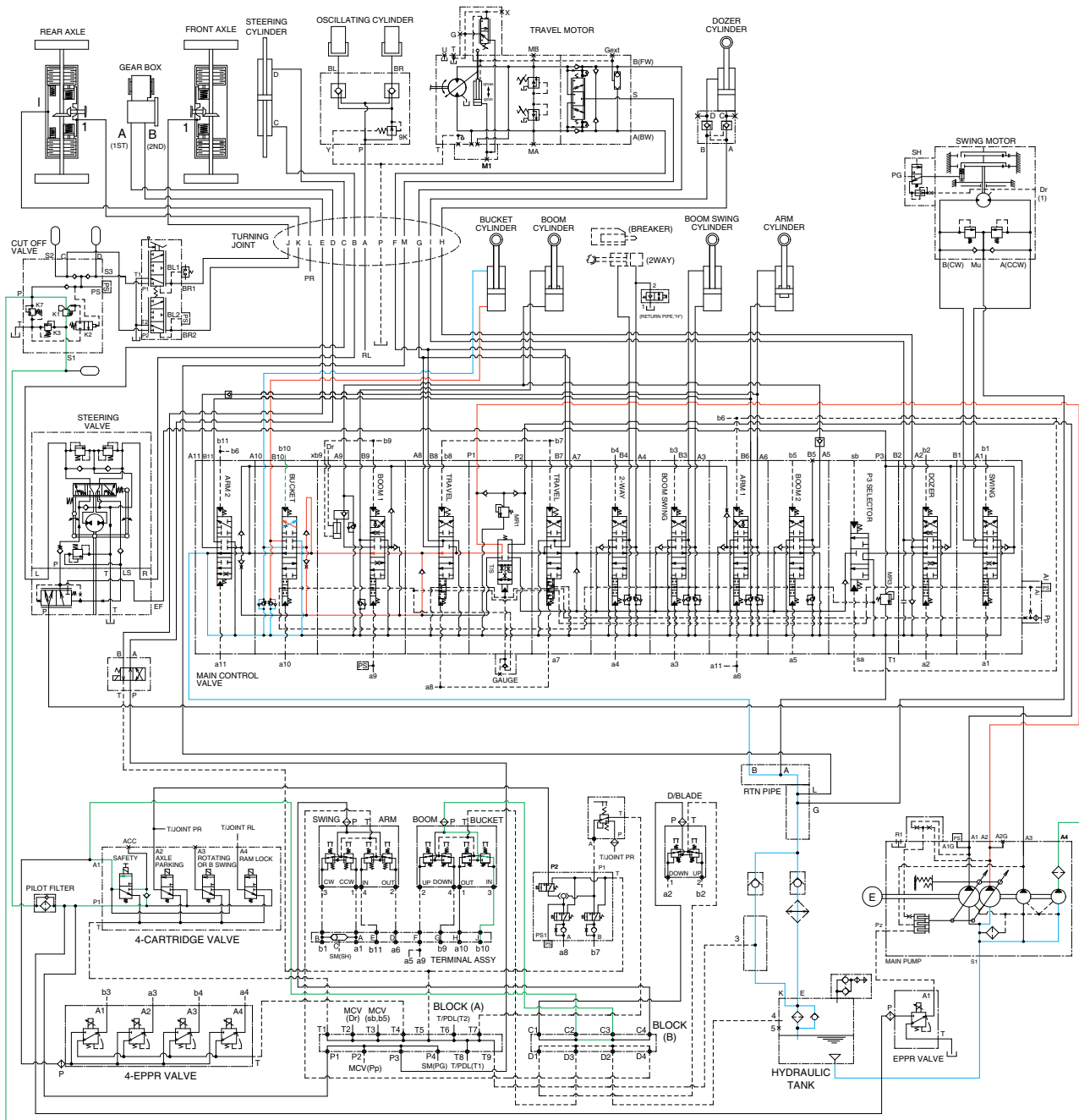

HW65AH3HC14

When the right control lever is pulled left, the bucket spool in the main control valve is moved to the roll in position by the pilot oil pressure (b10) from the remote control valve.

The oil from the A2 pump flows into the main control valve and then goes to the large chamber of bucket cylinder.

At the same time, the oil from the small chamber of bucket cylinder returns to the hydraulic oil tank through the bucket spool in the main control valve. When this happens, the bucket rolls in.

The cavitation which will happen to the bottom of the bucket cylinder is also prevented by the make-up valve in the main control valve.



## 7. SWING OPERATION

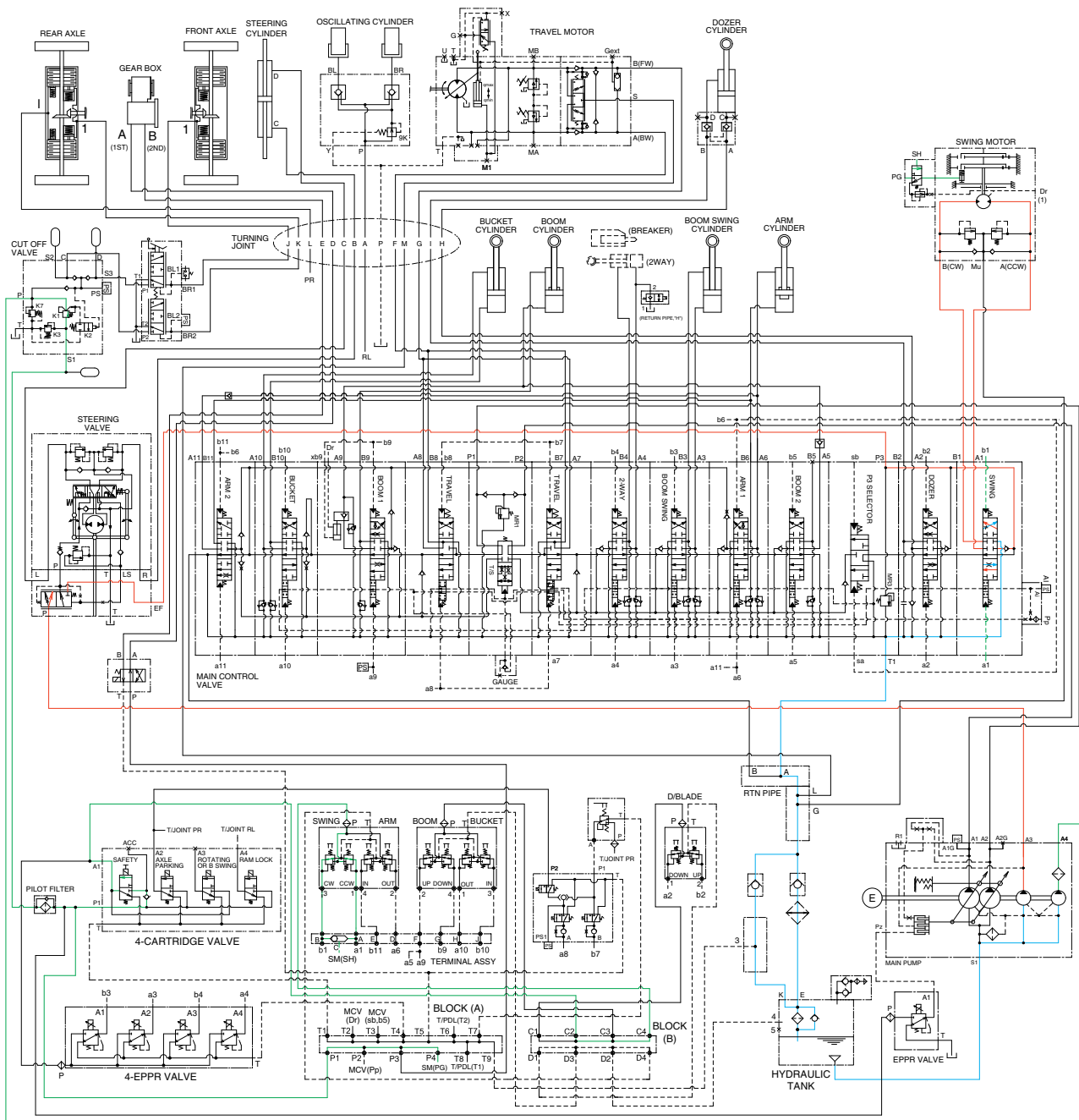

HW65AH3HC16

When the left control lever is pushed left or right, the swing spool in the main control valve is moved to the left or right swing position by the pilot oil pressure (a1, b1) from the remote control valve.

The oil from the A3 pump flows into the main control valve through the cut off valve and then goes to the swing motor.

At the same time, the return oil from the swing motor returns to the hydraulic oil tank through the swing spool in the main control valve. When this happens, the superstructure swings to the left or right. The swing parking brake, make up valve and the overload relief valve are provided in the swing motor. The cavitation which will happen to the swing motor is also prevented by the make up valve in the swing motor itself.

## SWING CIRCUIT OPERATION

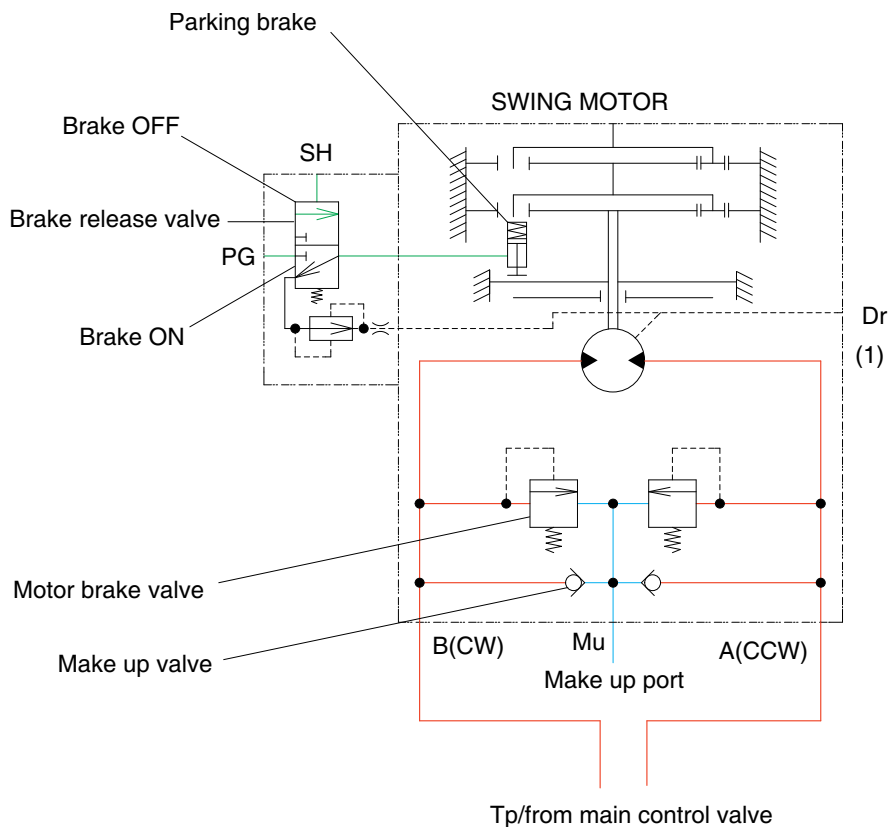

HW65AH3HC17

### 1) MOTOR BRAKE VALVE

Motor brake valve for the swing motor limits to cushion the starting and stopping pressure of swing operation.

### 2) MAKE UP VALVE

The make up valves prevent cavitation by supplying return oil to the vacuum side of the motor.

### 3) PARKING BRAKE

In case that the parking, of the machine at slope is required during operation, there is the danger of involuntary swing caused by the self weight of the machine. The brake is connected to prevent this involuntary swing.

#### PARKING BRAKE "OFF" OPERATION

The parking brake is released by the pilot pressure oil from the pilot pump.

When the left control lever placed in the swing position, the pilot pressure (SH) at the shuttle valve is transferred to the brake release valve and the brake release valve is change over. Then the pilot pressure (PG) lift the brake piston and release the parking brake.

#### PARKING BRAKE "ON" OPERATION

When the control lever placed in the neutral position, the pressure of the pilot oil passage down. Then the brake release valve returned to the neutral position and the oil is returned from the brake piston to the tank. And the brake is set to 'ON'.

## 8. TRAVEL FORWARD AND REVERSE OPERATION

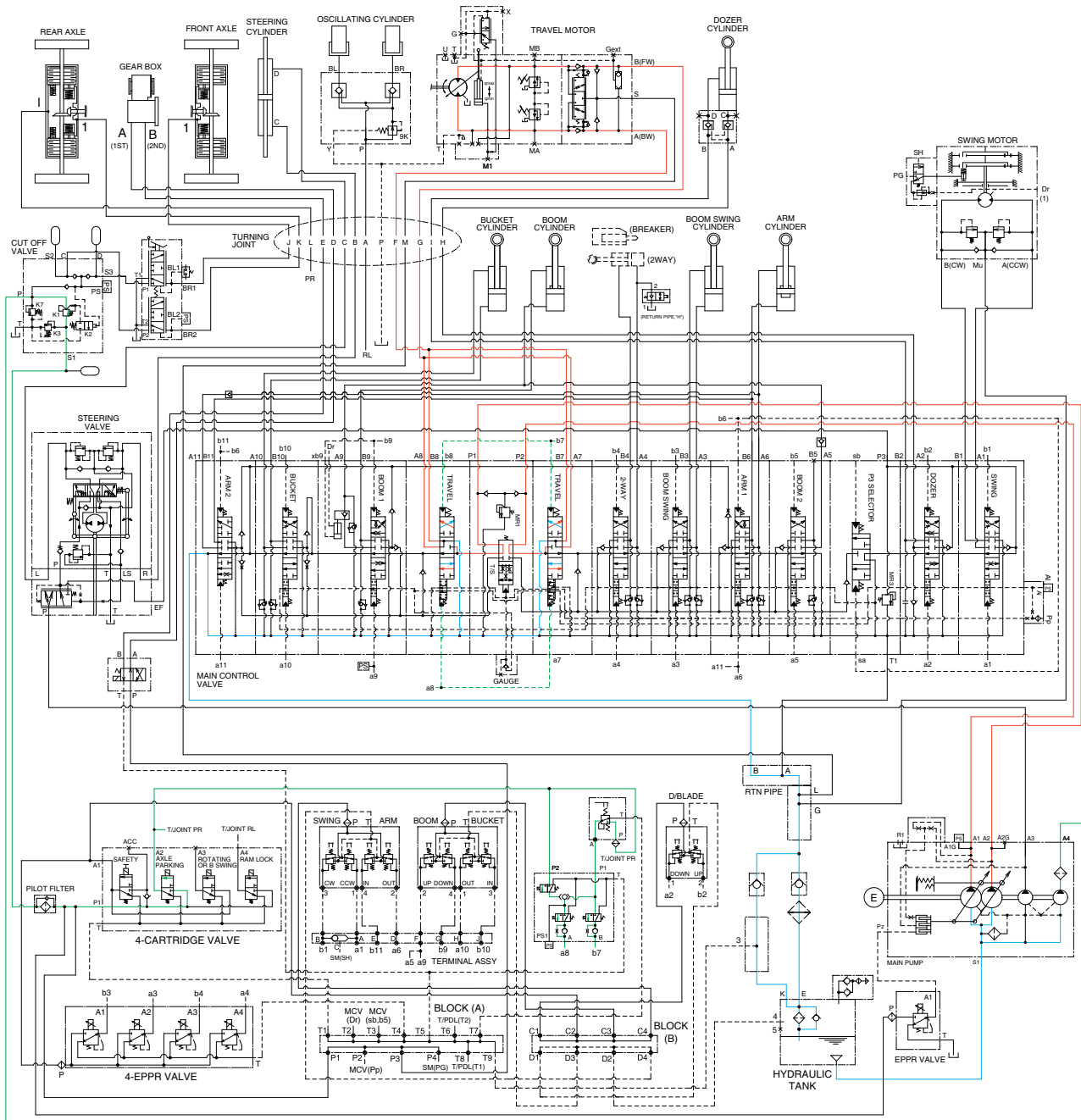

HW65AH3HC18

When the FNR lever of the RH multifunction switch is placed in forward or reverse position, the travel spools in the main control valve is moved to the forward or reverse position by the pilot oil pressure (a7, a8 or b7, b8) from pilot pump through the axle parking solenoid valve and then goes to the travel forward/reverse solenoid valve. The oil from the both pumps (A1, A2) flows into the main control valve and then goes to the travel motor. At the same time, the oil returned from the travel motor returns to the hydraulic oil tank through the turning joint and travel spools in the main control valve. When this happens, the machine moves forward or reverse.

## TRAVEL CIRCUIT OPERATION

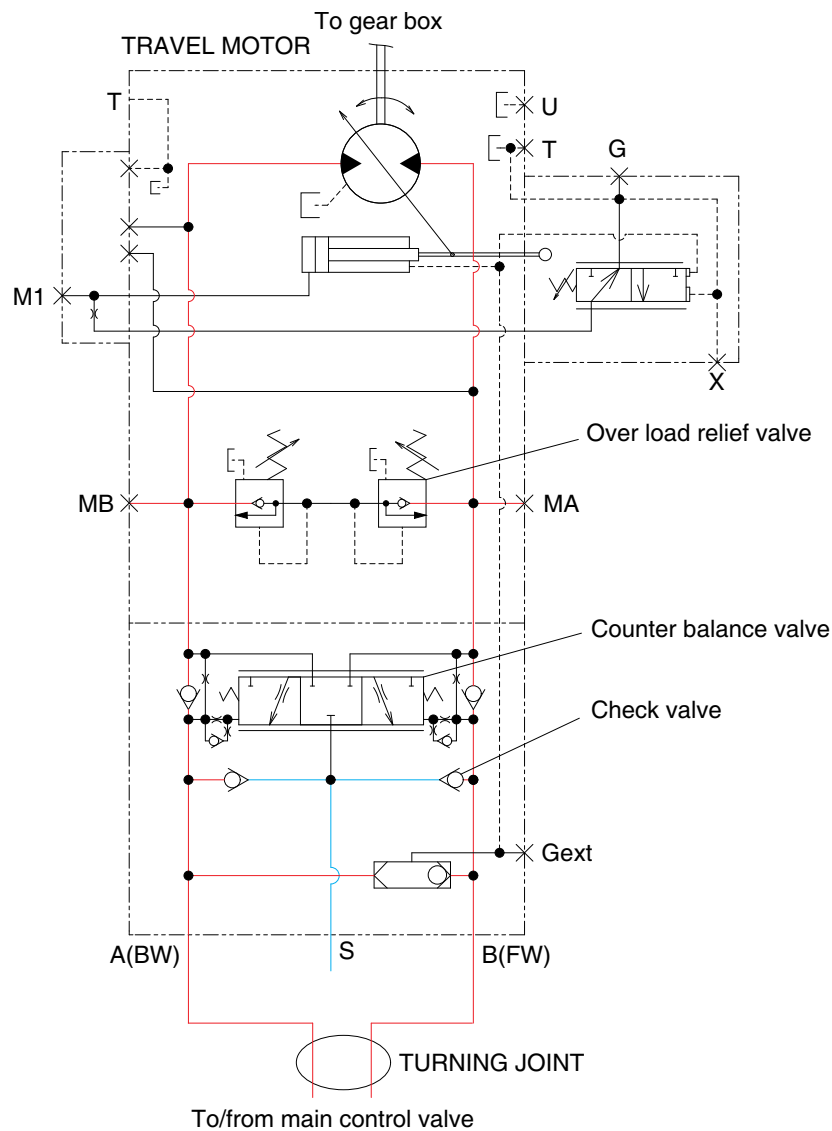

HW65AH3HC19

Valves are provided on travel motors to offer the following functions.

### 1) COUNTER BALANCE VALVE

When stopping the motor of slope descending, this valve to prevent the motor over run.

### 2) OVERLOAD RELIEF VALVE

Relief valve limit the circuit pressure below  $235 \text{ kgf/cm}^2$  (3340 psi) to prevent high pressure generated at the time of stopping the machine. Stopping the motor, this valve sucks the oil from lower pressure passage for preventing the negative pressure and the cavitation of the motor.

## 9. DOZER UP OPERATION

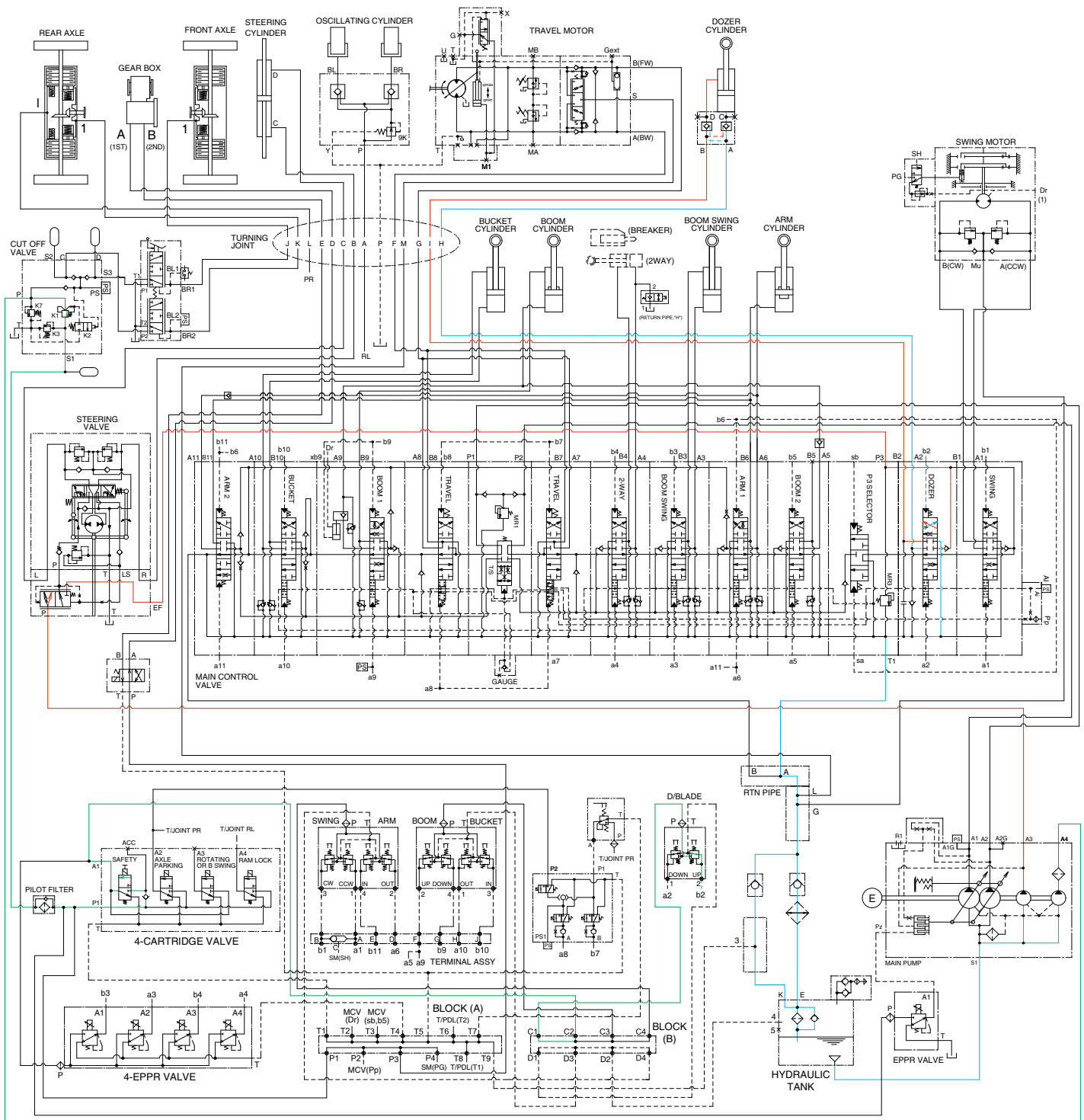

HW65AH3HC20

When the dozer control lever is pulled back, the dozer spool in the main control valve is moved to the dozer up position by the pilot oil pressure (b2) from the remote control valve.

The oil from the A3 pump flows into the main control valve and then goes to the small chamber of dozer cylinder.

At the same time, the oil from the large chamber of dozer cylinder returns to the hydraulic oil tank through the dozer spool in the main control valve. When this happens, the dozer goes up.

# 10. DOZER DOWN OPERATION

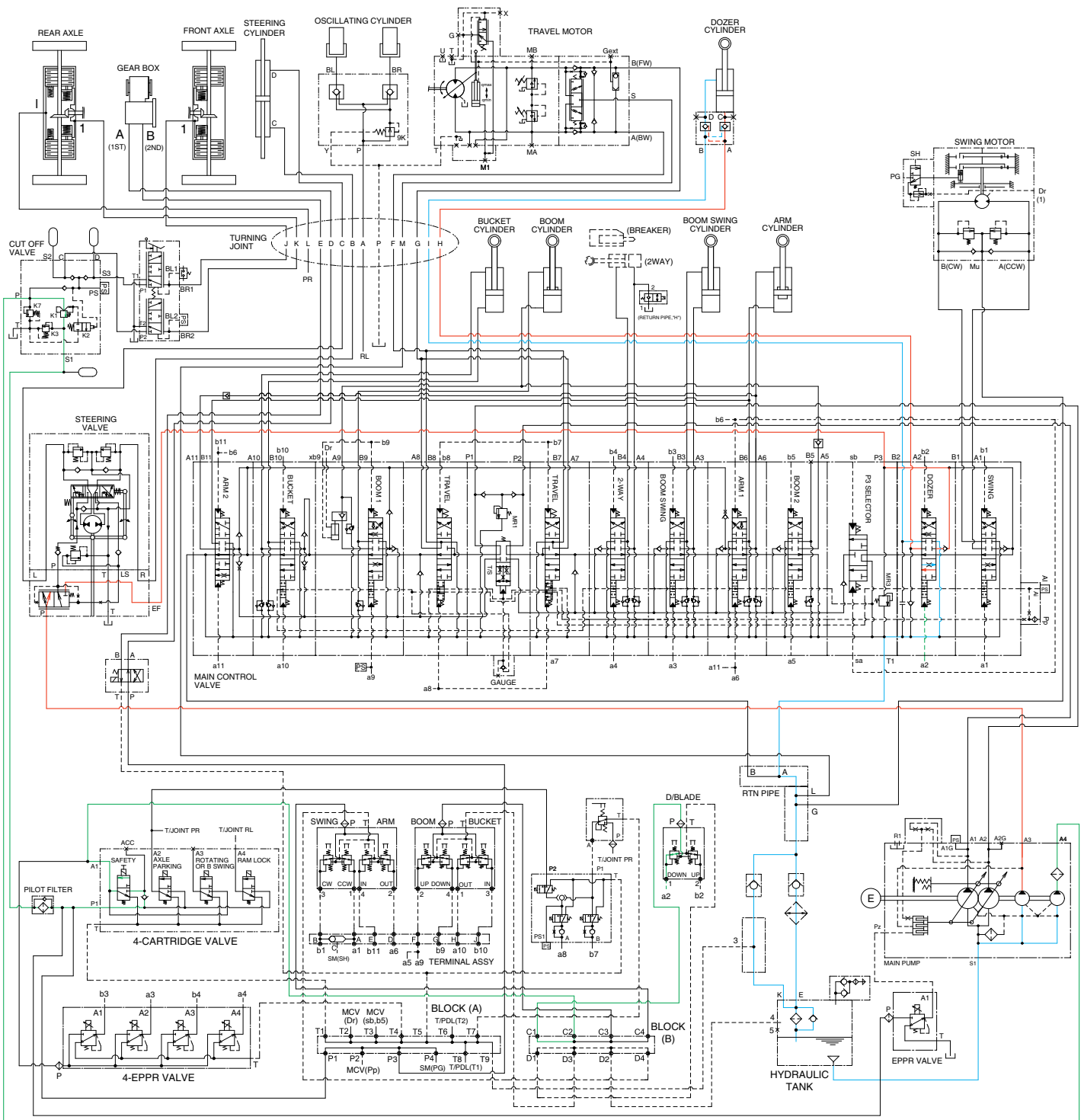

HW65AH3HC21

When the dozer control lever is pushed forward, the dozer spool in the main control valve is moved to the dozer down position by the pilot oil pressure (a2) from the remote control valve. The oil from the A3 pump flows into the main control valve and then goes to the large chamber of dozer cylinder. At the same time, the oil from the small chamber of dozer cylinder returns to the hydraulic oil tank through the dozer spool in the main control valve. When this happens, the dozer blade is down.



# 11. FRONT AND REAR AXLE BRAKE SYSTEM (SERVICE BRAKE)

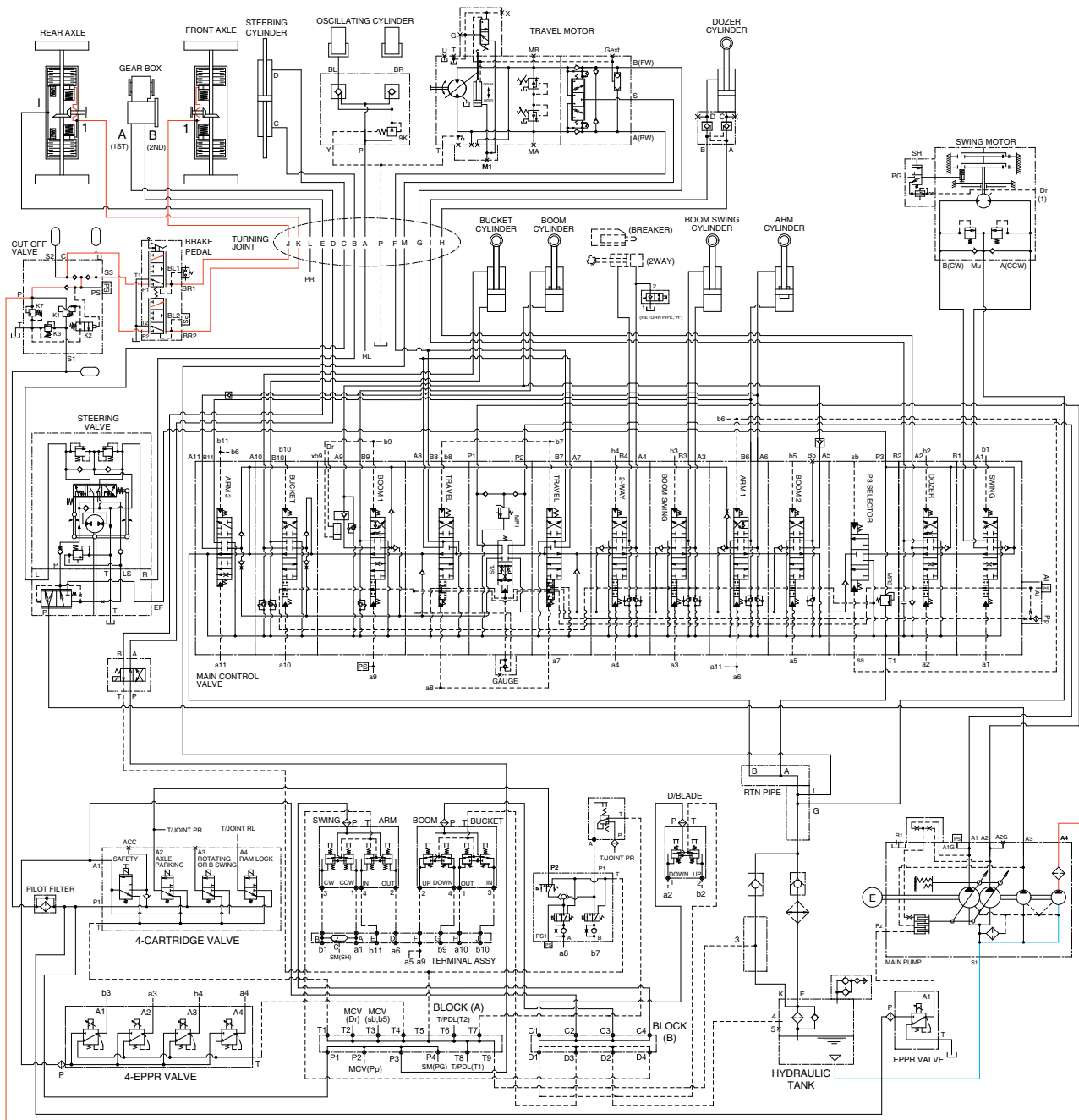

HW65AH3HC22

When the brake pedal (valve) is pushed, the discharged oil from the pilot pump (P4) flows into the front and rear axle brake disc through the solenoid valve of cut-off valve. This pressure is applied to axle brake disc, thus the service brake is applied.

## 12. STEERING CIRCUIT OPERATION

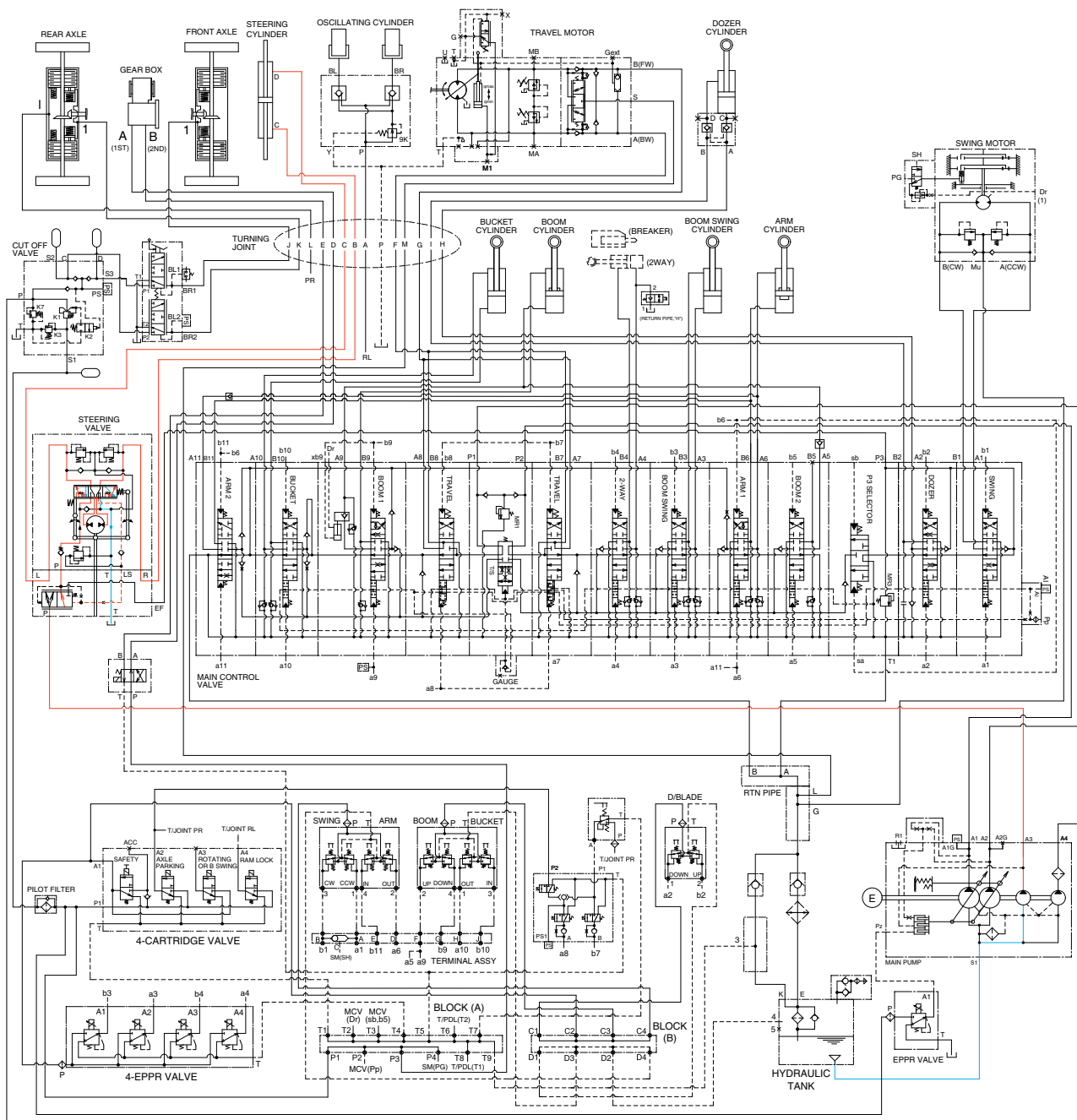

HW65AH3HC23

When the steering wheel is turned to the left or right, the spool within the steering valve turns left or right hand direction : Because the spool is connected with steering column.

At this time, the oil discharged from the pump (A3) flows into steering cylinder through spool and gerotor within the steering valve.

Then the steering direction is applied.

### 13. RAM LOCK CIRCUIT OPERATION

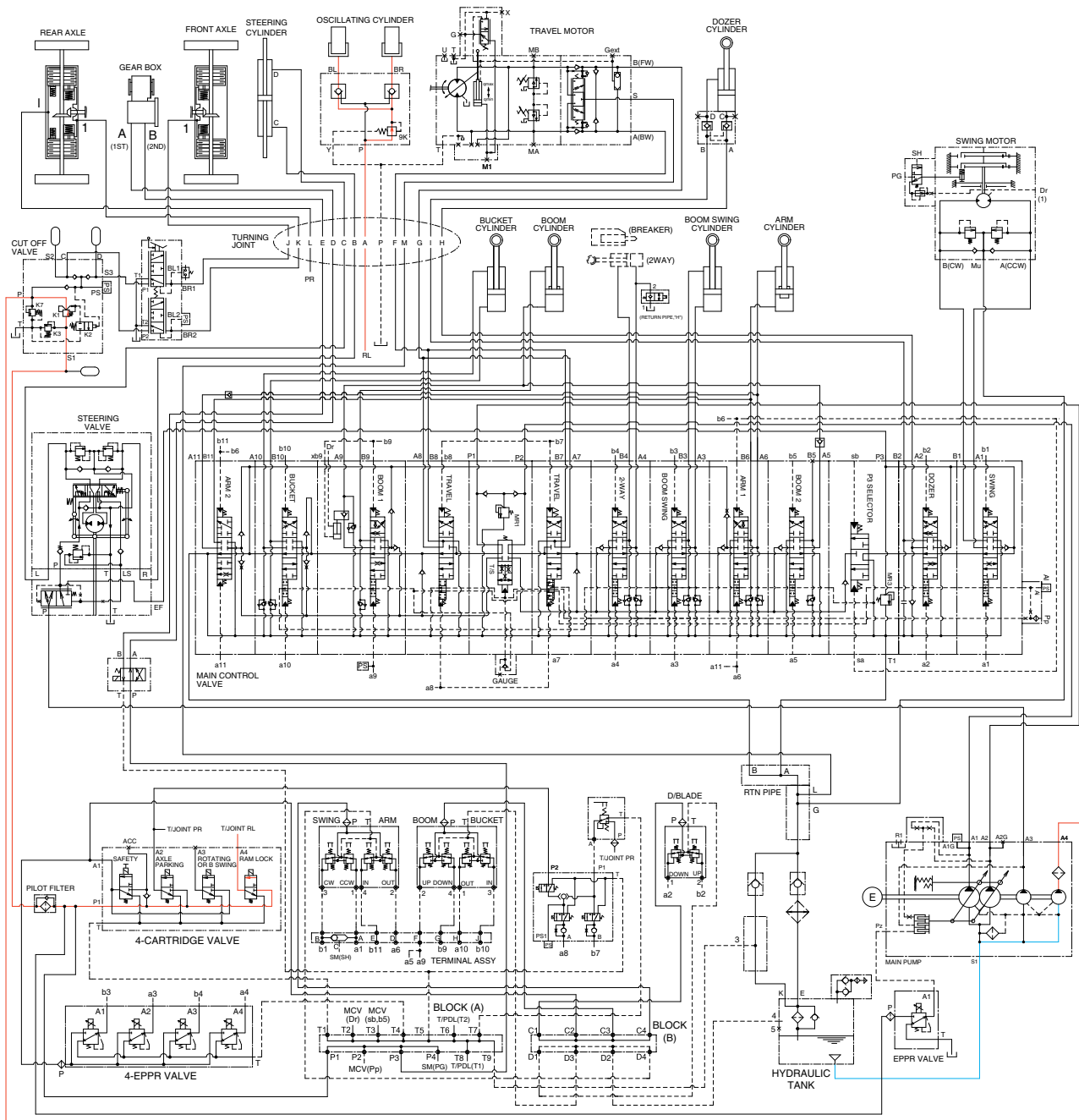

HW65AH3HC24

When the ram lock switch is selected on the switch panel, the oil discharged from the pilot pump flows into oscillating cylinder through ram lock solenoid valve and locking valve. This pressure is applied to check valve and oscillating cylinder, thus the oscillating function is operated (ram lock released).

# GROUP 5 COMBINED OPERATION

## 1. OUTLINE

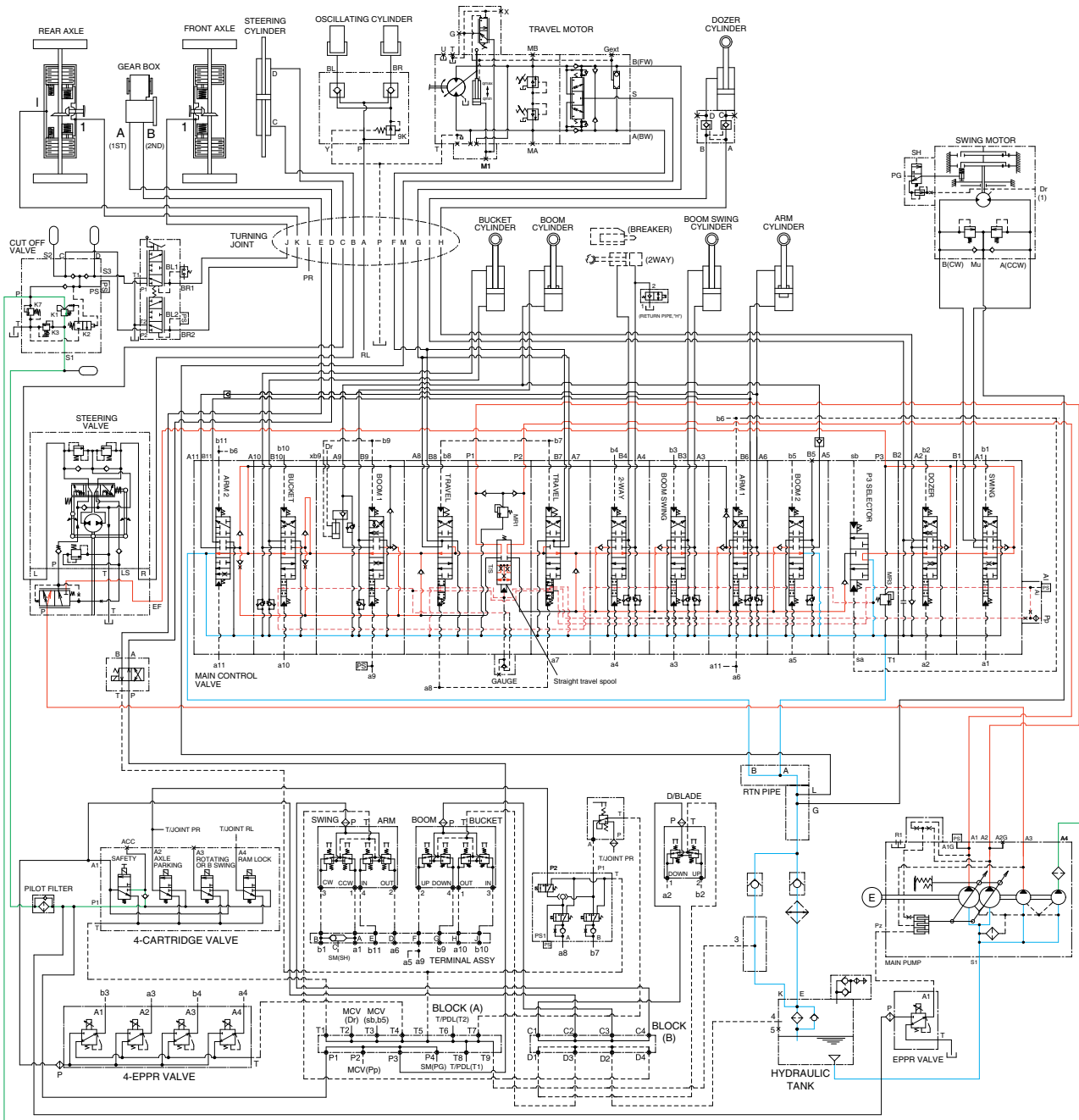

HW65AH3HC25

The oil from the A1, A2, A3 pump flows through the neutral oil passage, bypass oil passage and confluence oil passage in the main control valve. Then the oil goes to each actuator and operates them. Check valves and orifices are located on these oil passage in the main control valve. These control the oil from the main pumps so as to correspond to the operation of each actuator and smooth the combined operation.

### Straight travel spool

This straight travel spool for straight travel is provided in the main control valve.

If any of boom, arm or bucket lever etc is operated when traveling, the straight travel spool is pushed to the up by the pilot oil pressure.

Consequently, the left and right travel oil supply passage are connected, and equivalent amount of oil flows into the left and right travel motors. This keeps the straight travel.

## 2. COMBINED SWING AND BOOM OPERATION

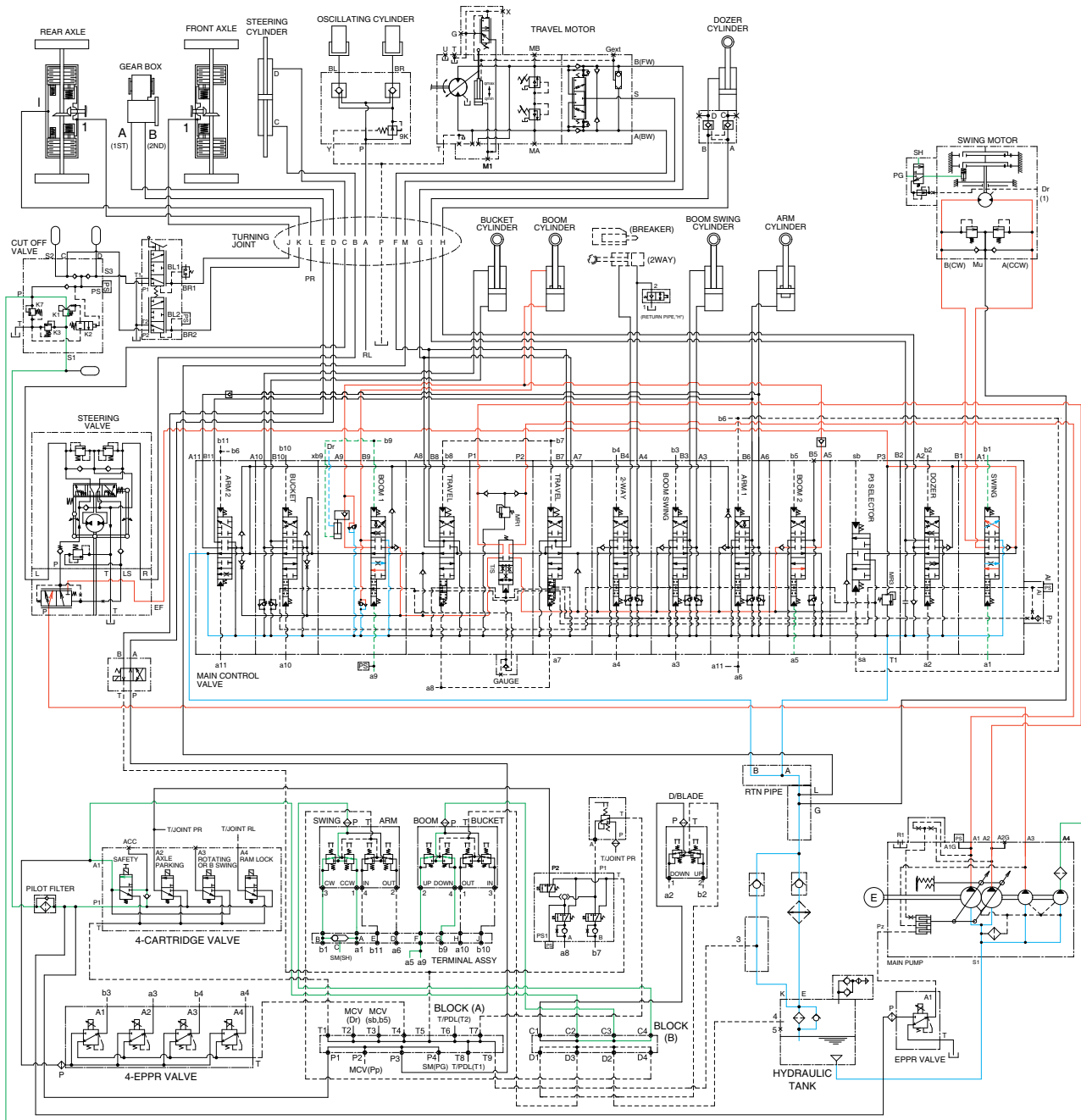

HW65AH3HC26

When the swing and boom functions are operated, simultaneously the swing spool and boom spools in the main control valve are moved to the functional position by the pilot oil pressure (a1, b1, a5, a9, b9) from the remote control valve.

The oil from the A1 and A2 pump flows into the boom cylinder through boom 1 and boom 2 spools.

The oil from the A3 pump flows into the swing motor through the swing spool.

The superstructure swings and the boom is operated.

### 3. COMBINED SWING AND ARM OPERATION

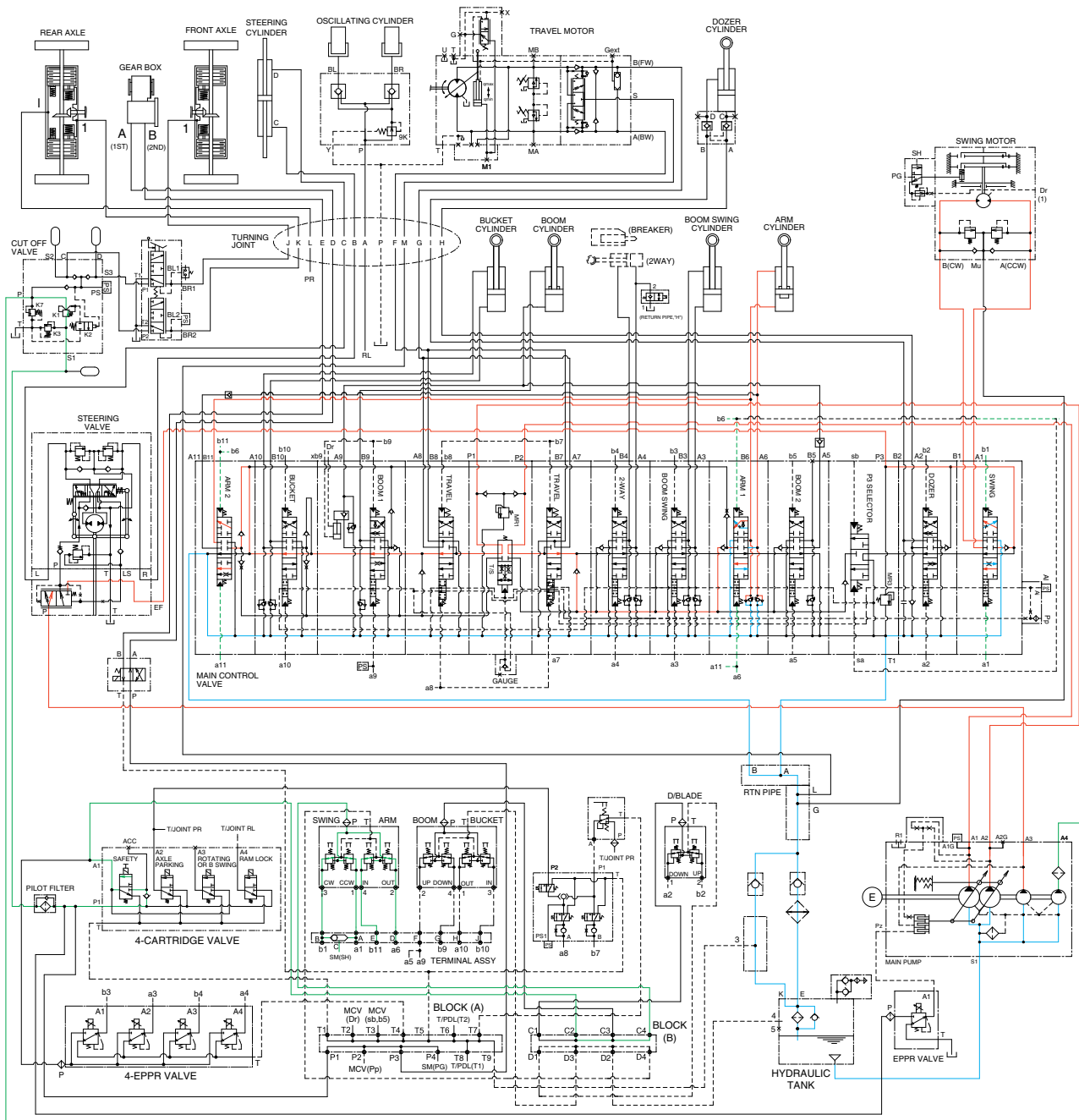

HW65AH3HC27

When the swing and arm functions are operated, simultaneously the swing spool and arm spools in the main control valve are moved to the functional position by the pilot oil pressure (a1, b1, a6, a11, b6, b11) from the remote control valve.

The oil from the A3 pump flows into the swing motor through swing spool.

The oil from the A1 and A2 pump flows into the arm cylinder through the arm 1 and arm 2 spools.

The superstructure swings and the arm is operated.

## 4. COMBINED SWING AND BUCKET OPERATION

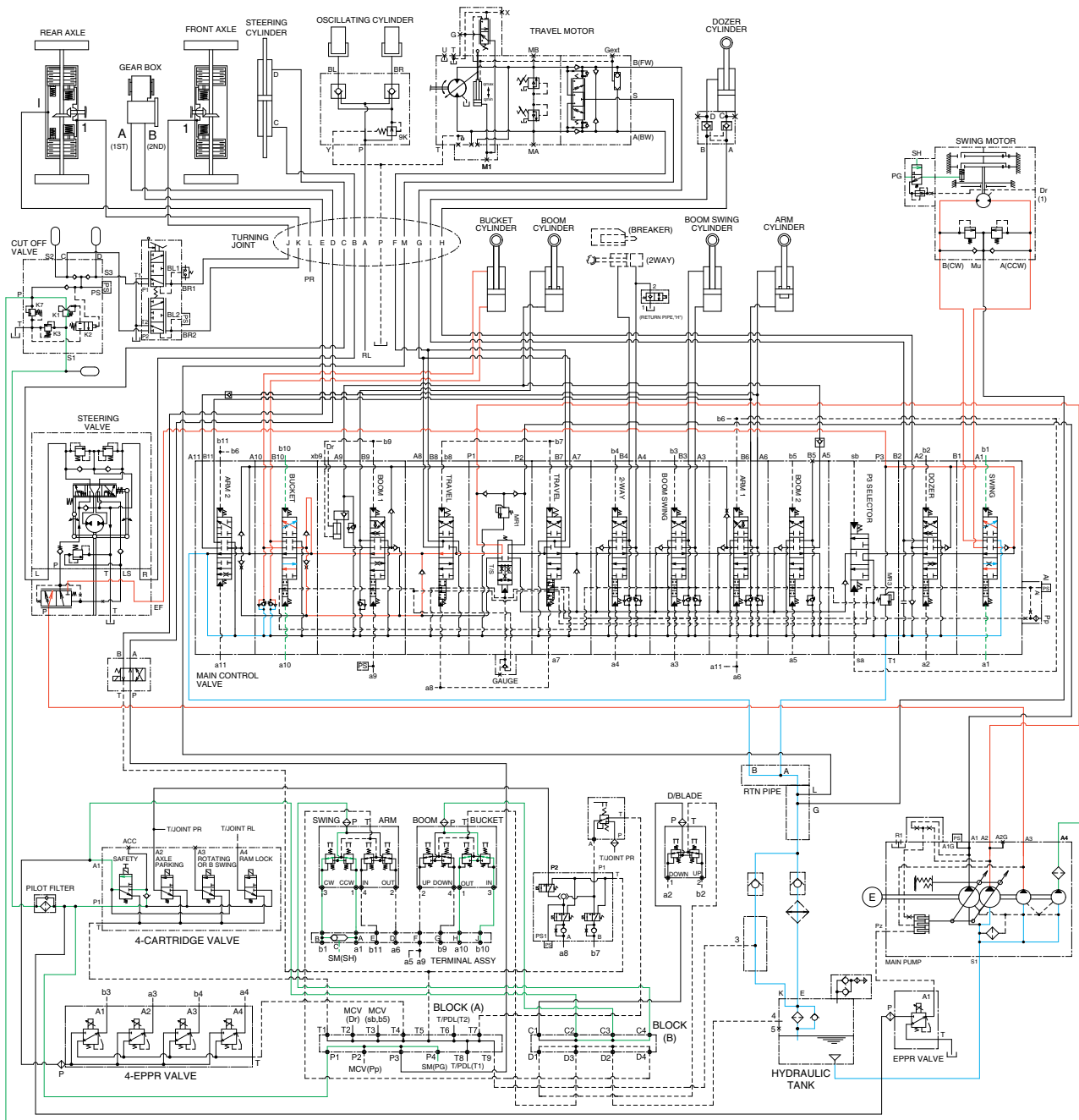

HW65AH3HC28

When the swing and bucket functions are operated, simultaneously the swing spool and bucket spool in the main control valve are moved to the functional position by the pilot oil pressure (a1, b1, a10, b10) from the remote control valve.

The oil from the A3 pump flows into the swing motor through the swing spool.

The oil from the A2 pump flows into the bucket cylinder through the bucket spool.

The superstructure swings and the bucket is operated.

## 5. COMBINED SWING, BOOM, ARM AND BUCKET OPERATION

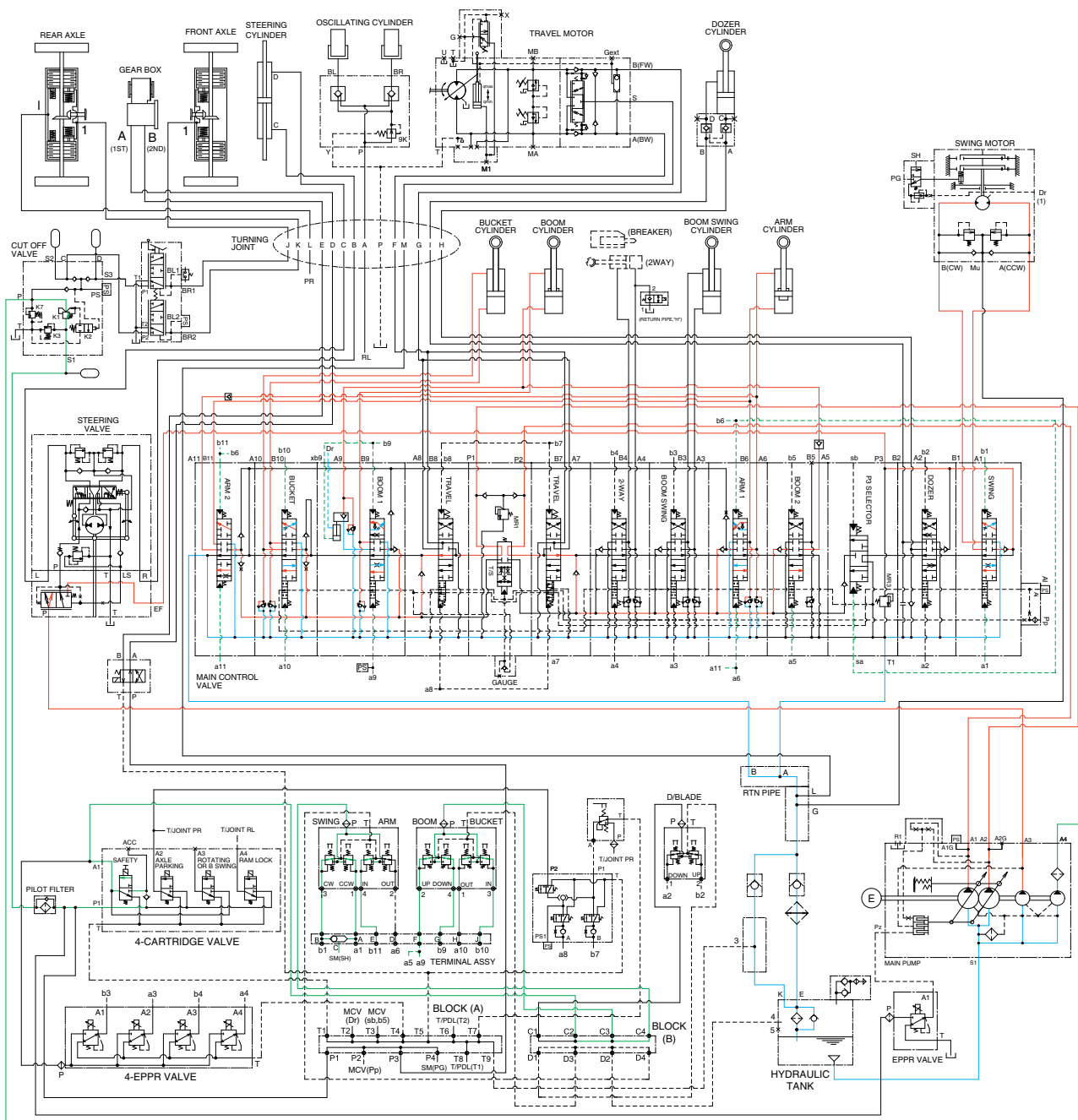

HW65AH3HC29

When the swing, boom, arm and bucket functions are operated, simultaneously each spool in the main GEAR control valve is moved to the functional position by the pilot oil pressure (a1, b1, a5, a9, b9, a6, a11, b6, b11, a10, b10) from the remote control valve.

The oil from the A2 pump flows into the boom cylinder, arm cylinder and bucket cylinder through boom 1 spool, arm 2 spool, bucket spool.

The oil from the A1 pump flows into the boom cylinder and arm cylinder through the boom 2 spool and arm 1 spool.

The oil from the A3 pump flows into the swing motor through the swing spool.

The superstructure swings and the boom, arm and bucket are operated.