

## SECTION 4 ELECTRICAL SYSTEM

Group 1 Component Location .....	4-1
Group 2 Electrical Circuit .....	4-3
Group 3 Electrical Component Specification .....	4-25
Group 4 Connectors .....	4-37

# SECTION 4 ELECTRICAL SYSTEM

## GROUP 1 COMPONENT LOCATION

### 1. LOCATION 1

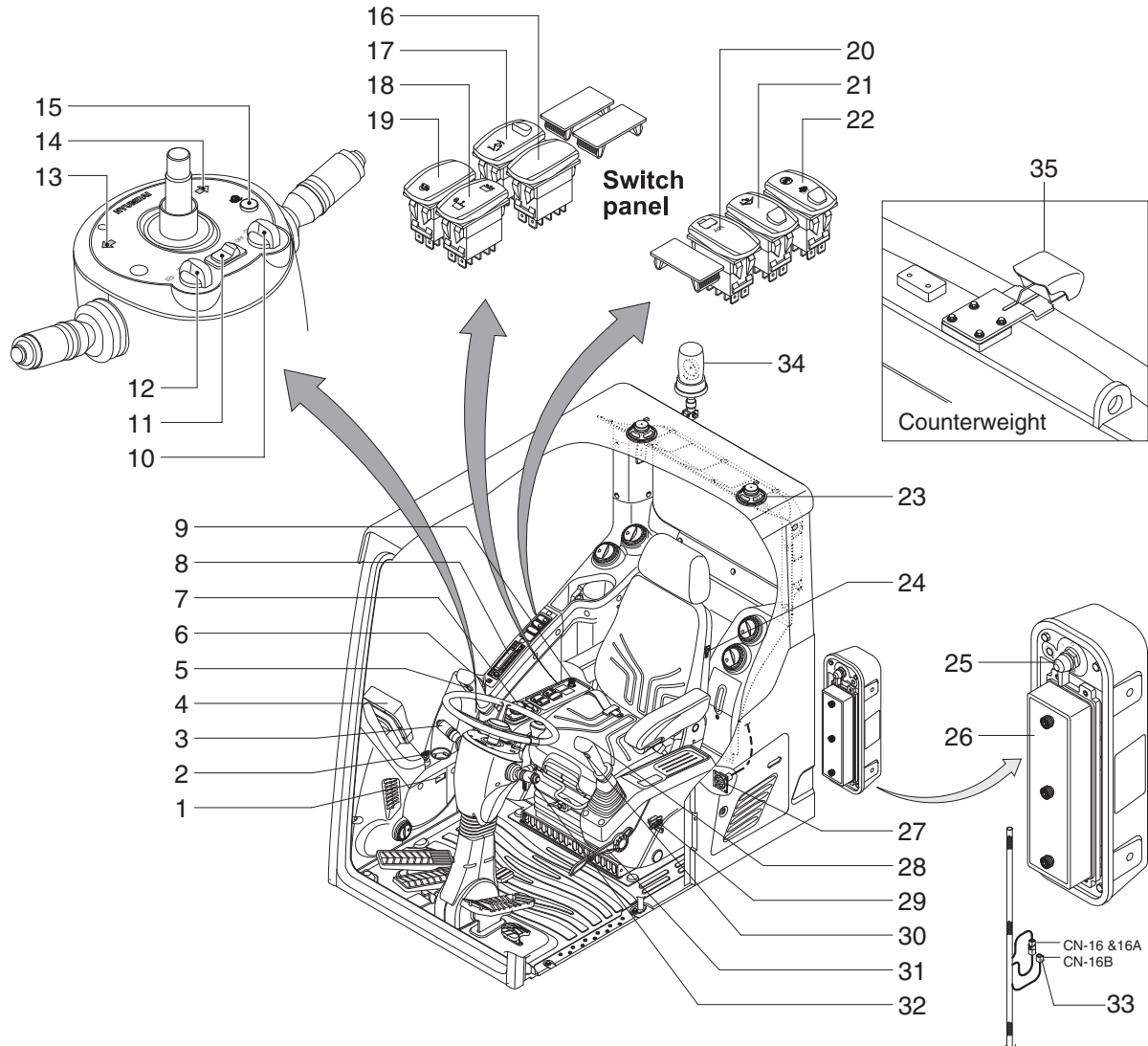

210WF4EL01

- |                              |                               |   |
|------------------------------|-------------------------------|---|
| 1 Service meter              | 13 Left turning pilot lamp    | 25 Master switch                            |
| 2 Start switch               | 14 Right turning pilot lamp   | 26 Fuse & relay box                         |
| 3 Multi function switch (RH) | 15 Creep button               | 27 RS232 & J1939 service socket             |
| 4 Cluster                    | 16 Option attach switch       | 28 One touch decel switch                   |
| 5 Breaker operation switch   | 17 Boom floating switch       | 29 Emergency engine stop switch             |
| 6 Horn switch                | 18 Swing lock/fine switch     | 30 Power max switch                         |
| 7 Haptic controller          | 19 Creep switch               | 31 Safety lever                             |
| 8 Radio & USB player         | 20 Air compressor switch      | 32 Multi function switch (LH)               |
| 9 Cigar lighter              | 21 Quick clamp switch         | 33 Emergency engine speed control connector |
| 10 Ram lock rotary switch    | 22 SCR system cleaning switch |   |
| 11 Hazard switch             | 23 Speaker                    | 34 Beacon lamp                              |
| 12 Select rotary switch      | 24 Heated seat switch         | 35 Rear view camera                         |

## 2. LOCATION 2

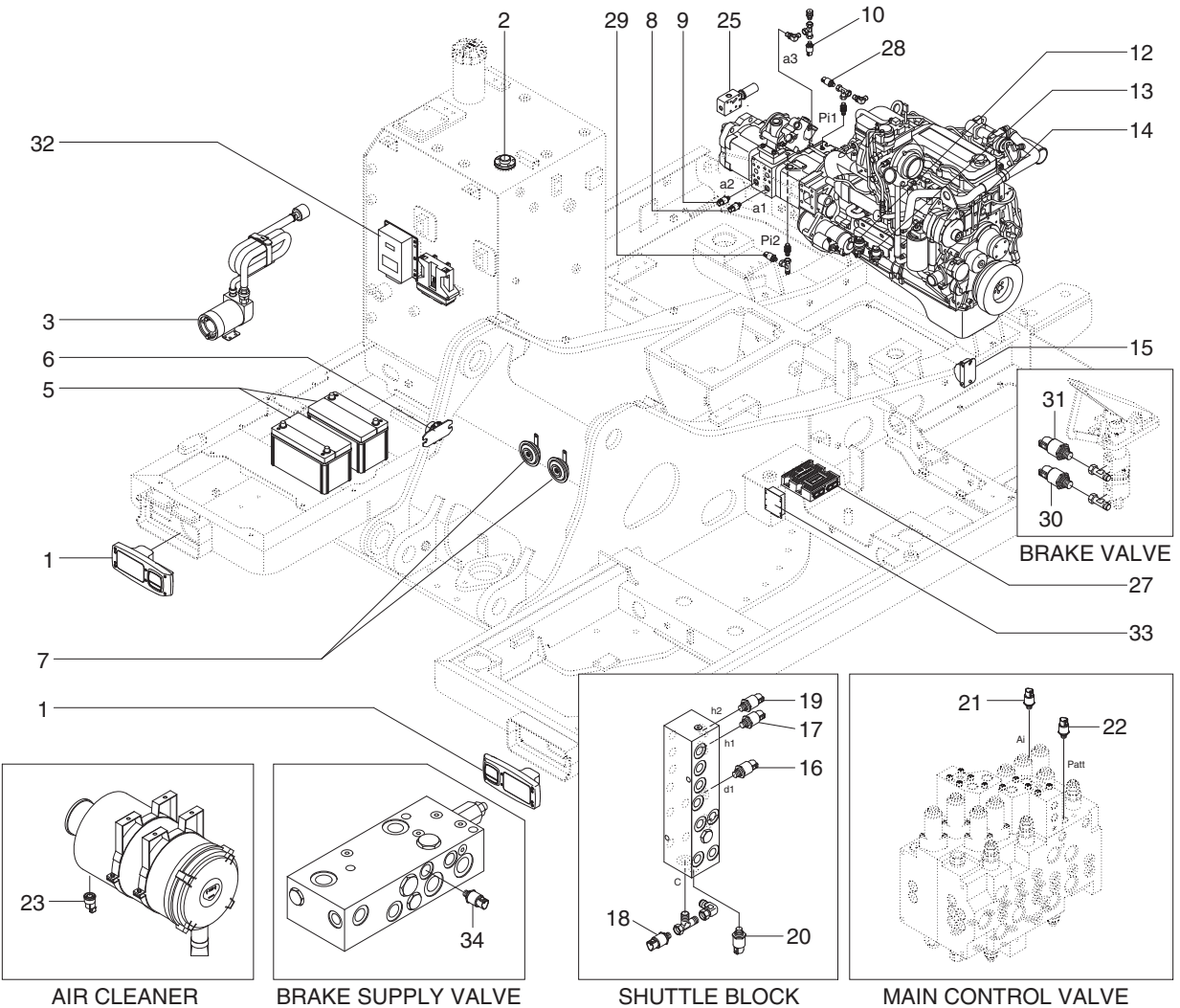
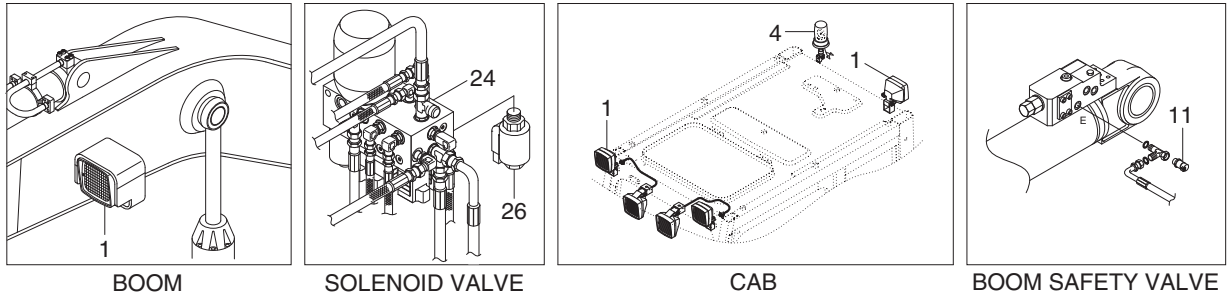

140WF4EL02

- |                             |                                  |                                     |
|-----------------------------|----------------------------------|-------------------------------------|
| 1 Lamp                      | 13 Heater relay                  | 25 Pump EPPR valve                  |
| 2 Fuel sender               | 14 Alternator                    | 26 Boom priority EPPR valve         |
| 3 Fuel filler pump          | 15 Travel alarm buzzer           | 27 MCU                              |
| 4 Beacon lamp               | 16 Arm/Bucket in pressure sensor | 28 Nega 1 pressure sensor           |
| 5 Battery                   | 17 Boom up pressure sensor       | 29 Nega 2 pressure sensor           |
| 6 Battery relay             | 18 Swing pressure sensor         | 30 Brake pressure sensor            |
| 7 Horn                      | 19 Boom down pressure sensor     | 31 Brake pilot lamp pressure switch |
| 8 P1 pressure sensor        | 20 Arm in pressure sensor        | 32 MCU (opt)                        |
| 9 P2 pressure sensor        | 21 Travel pressure sensor        | 33 MCU (opt)                        |
| 10 EPPR pressure sensor     | 22 Attachment pressure sensor    | 34 Transmission oil pressure sensor |
| 11 Overload pressure sensor | 23 Air cleaner sensor            |                                     |
| 12 Start relay              | 24 5 cartridge valve             |                                     |





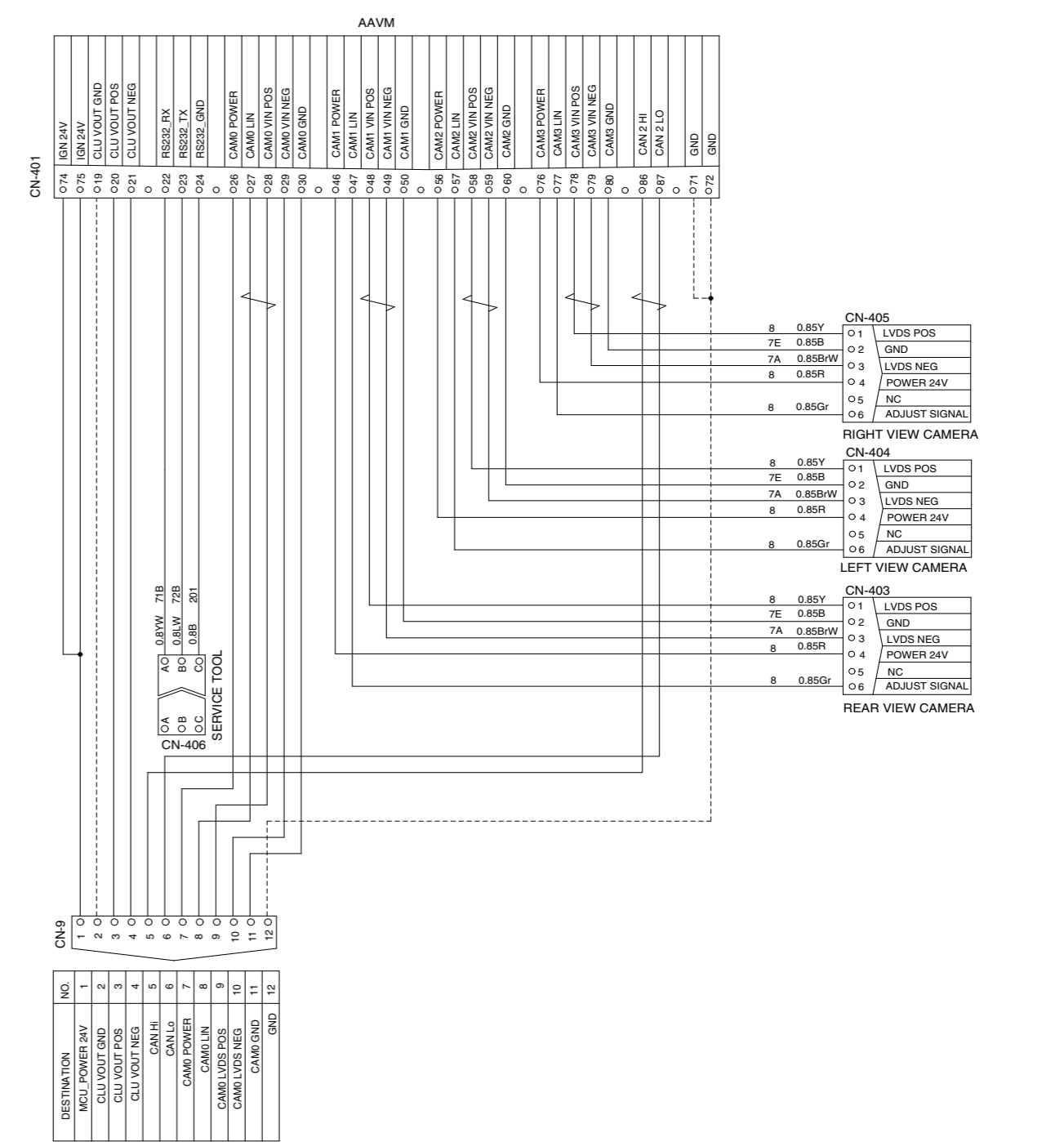
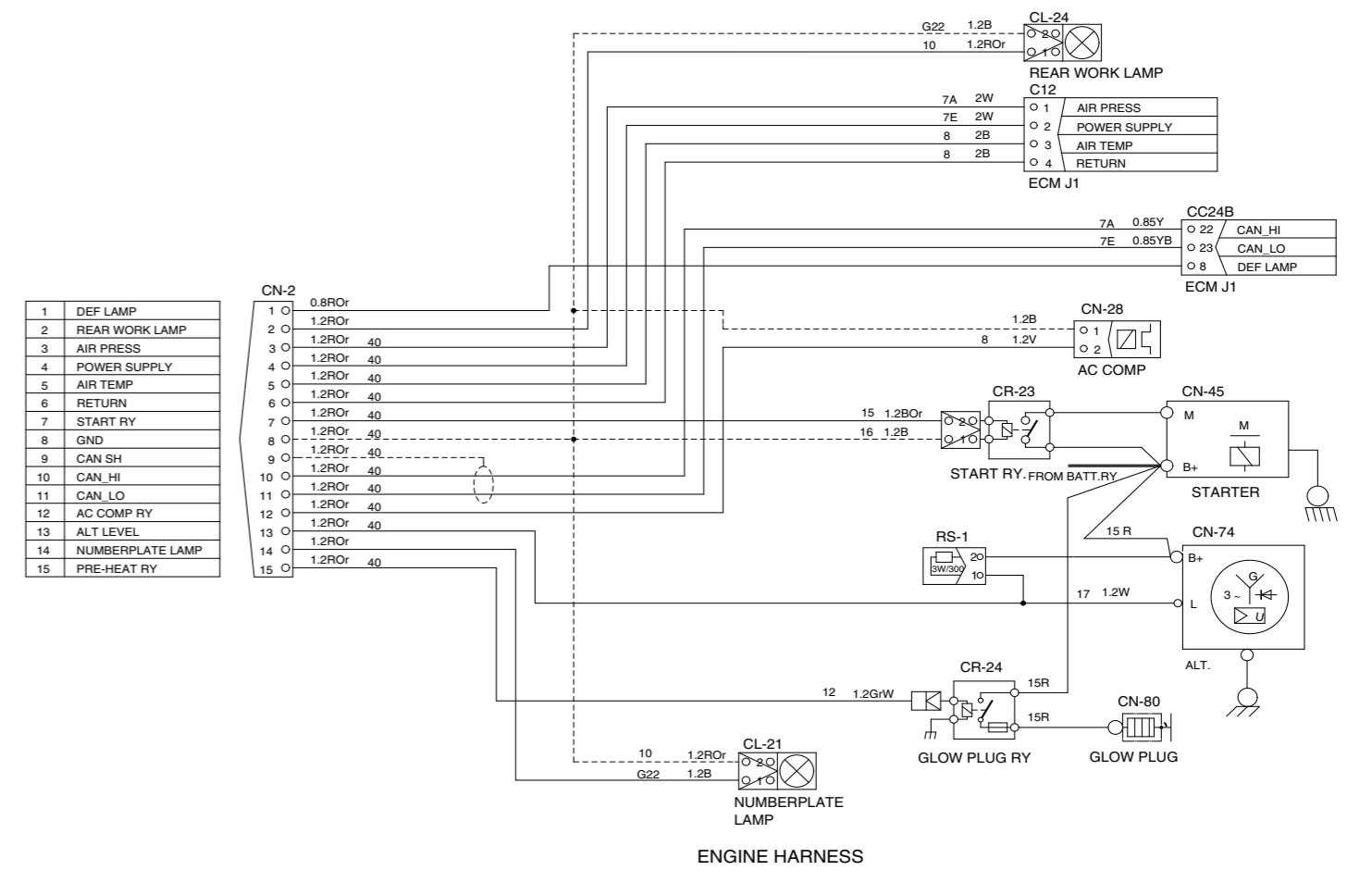
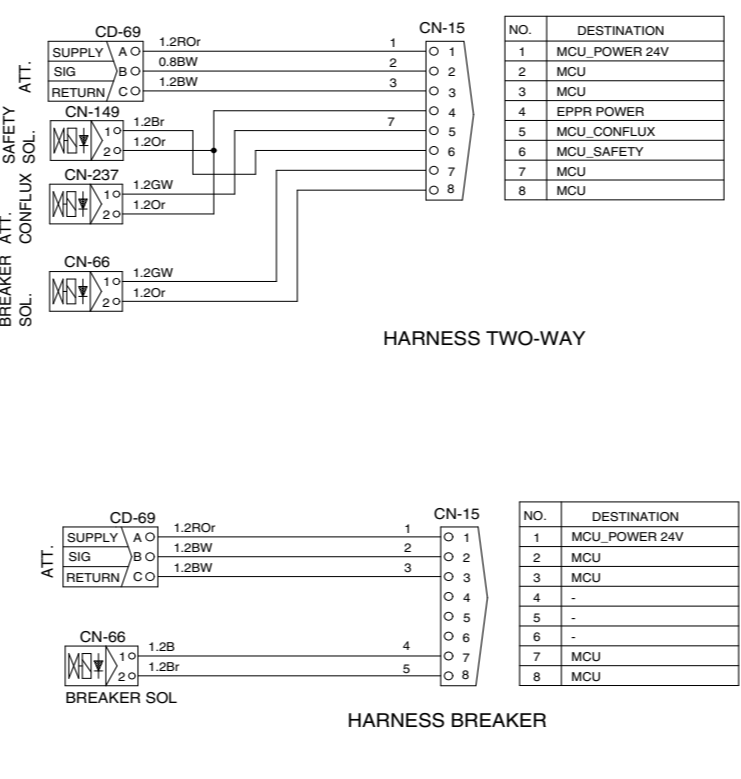
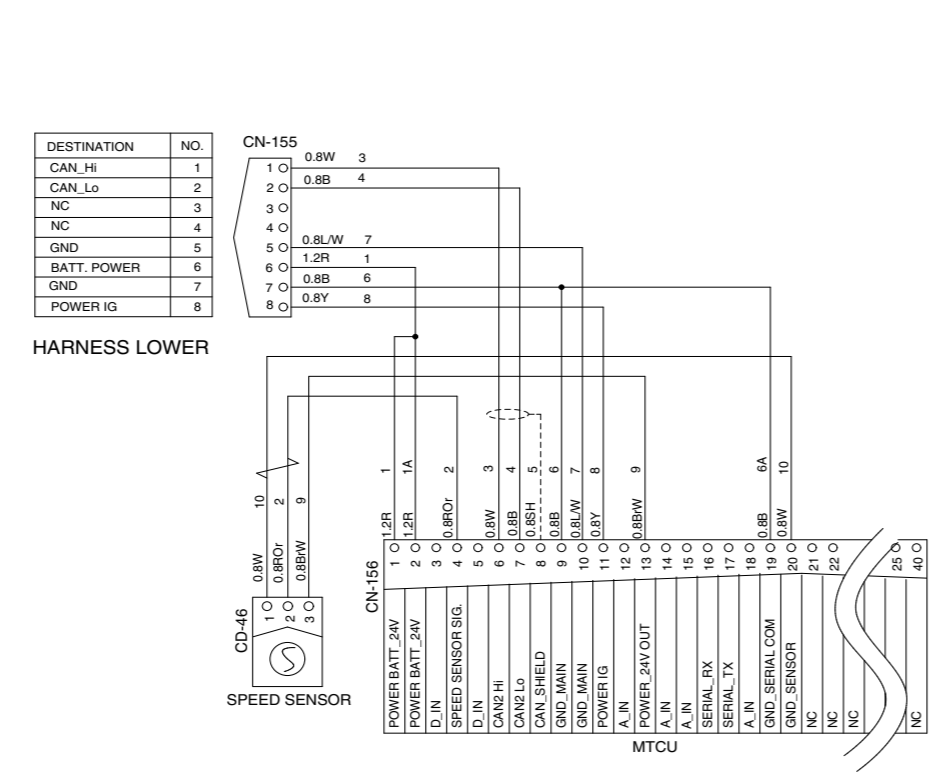
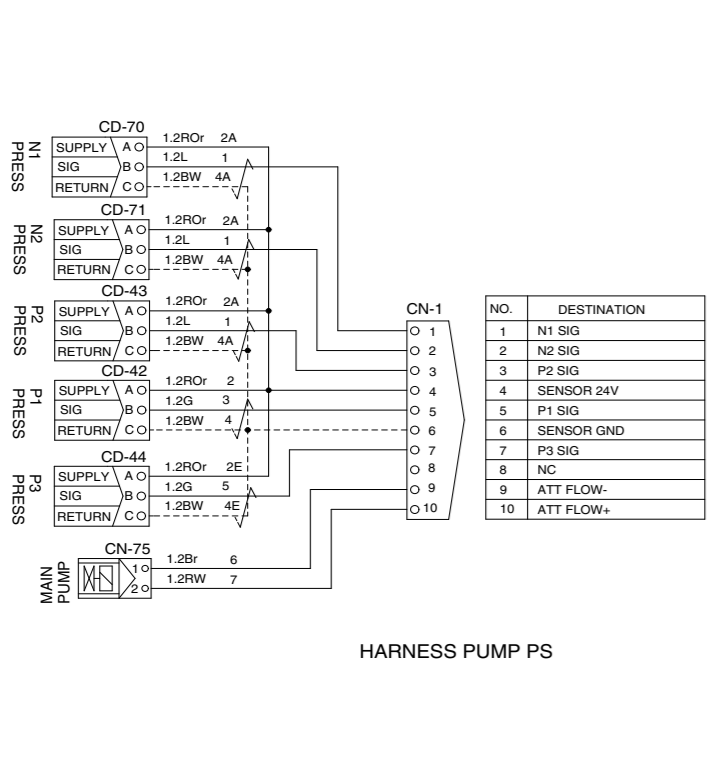
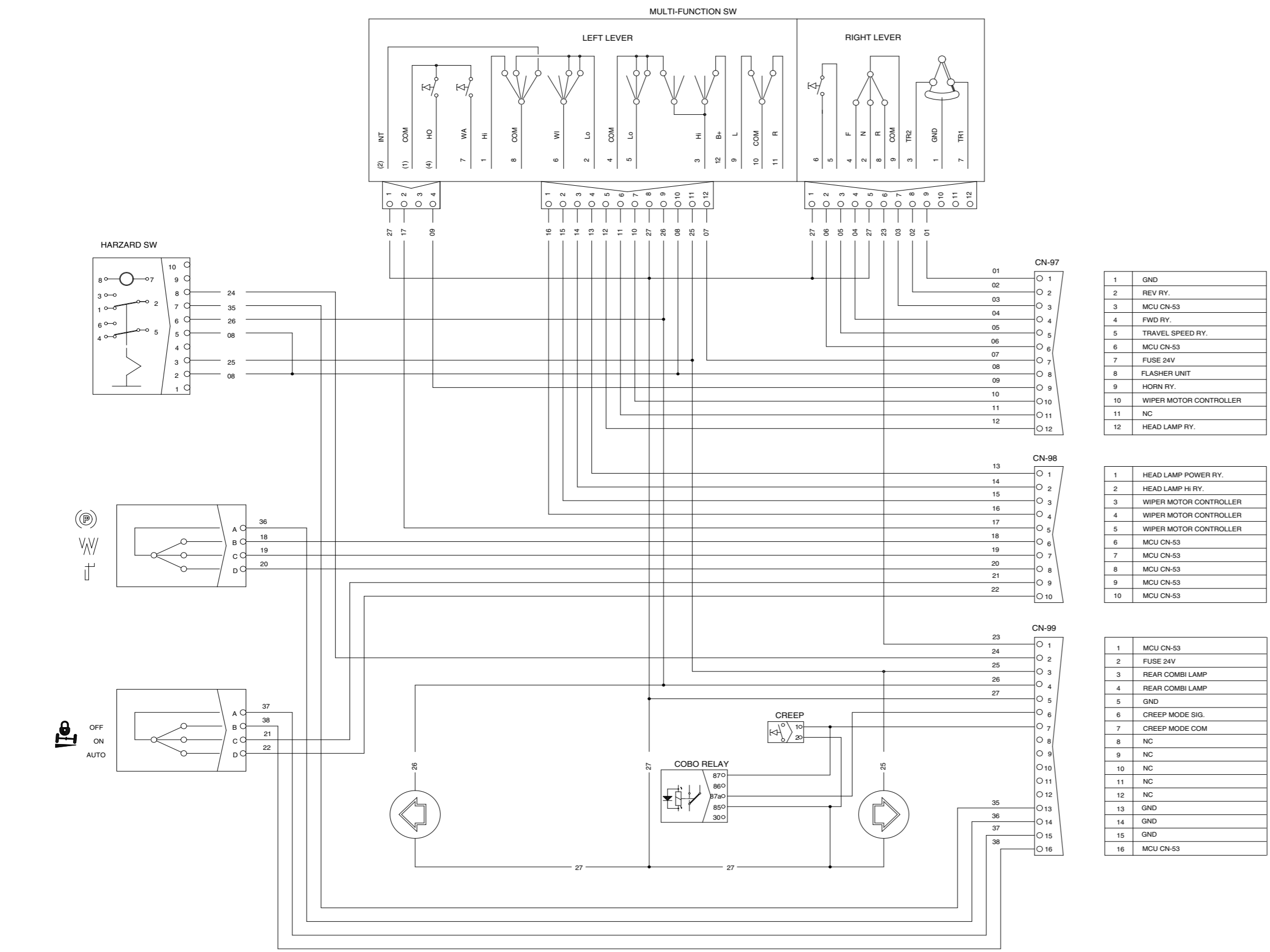

ELECTRICAL CIRCUIT (4/6, SERIAL NO. HW160 : #0176- / HW180 : #0095-)

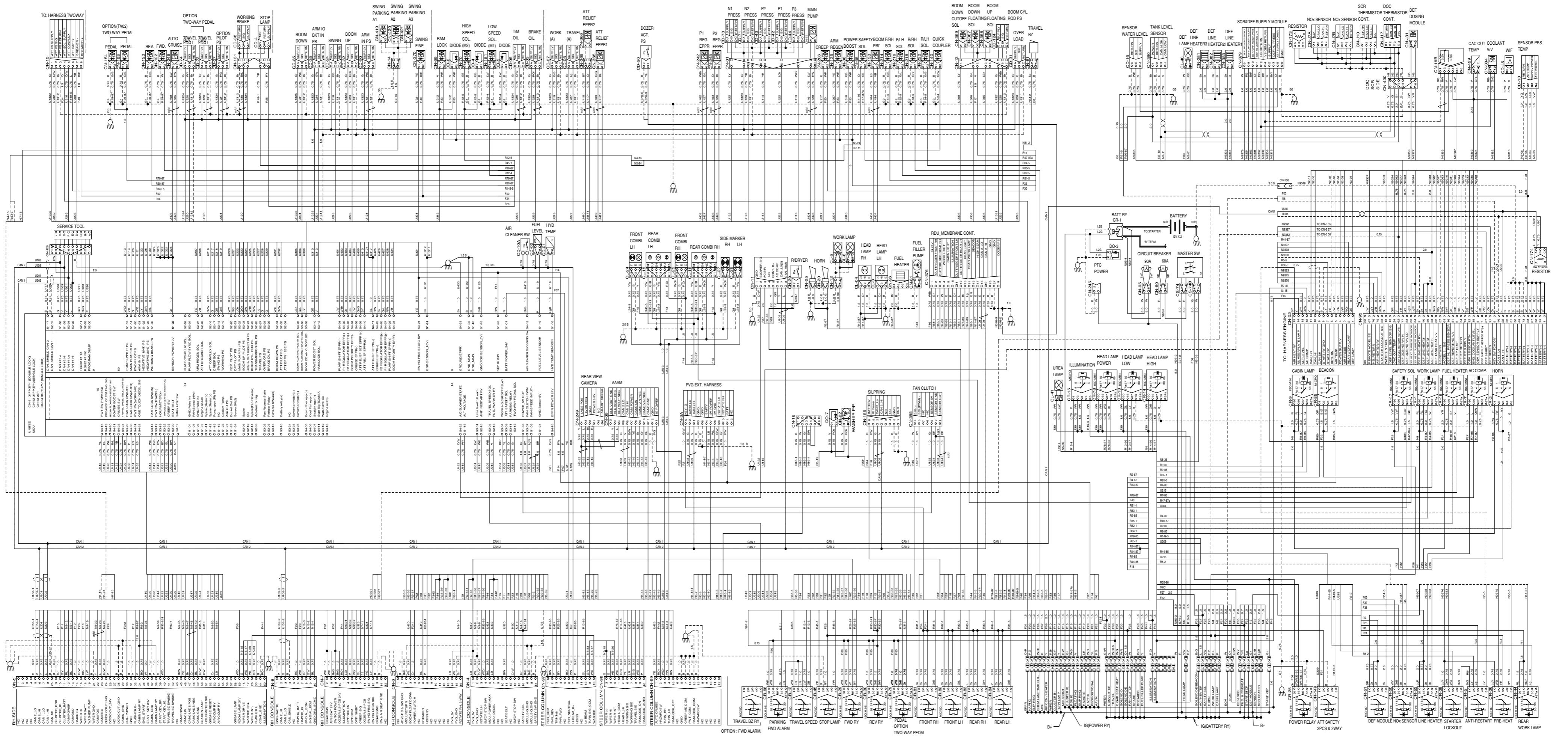

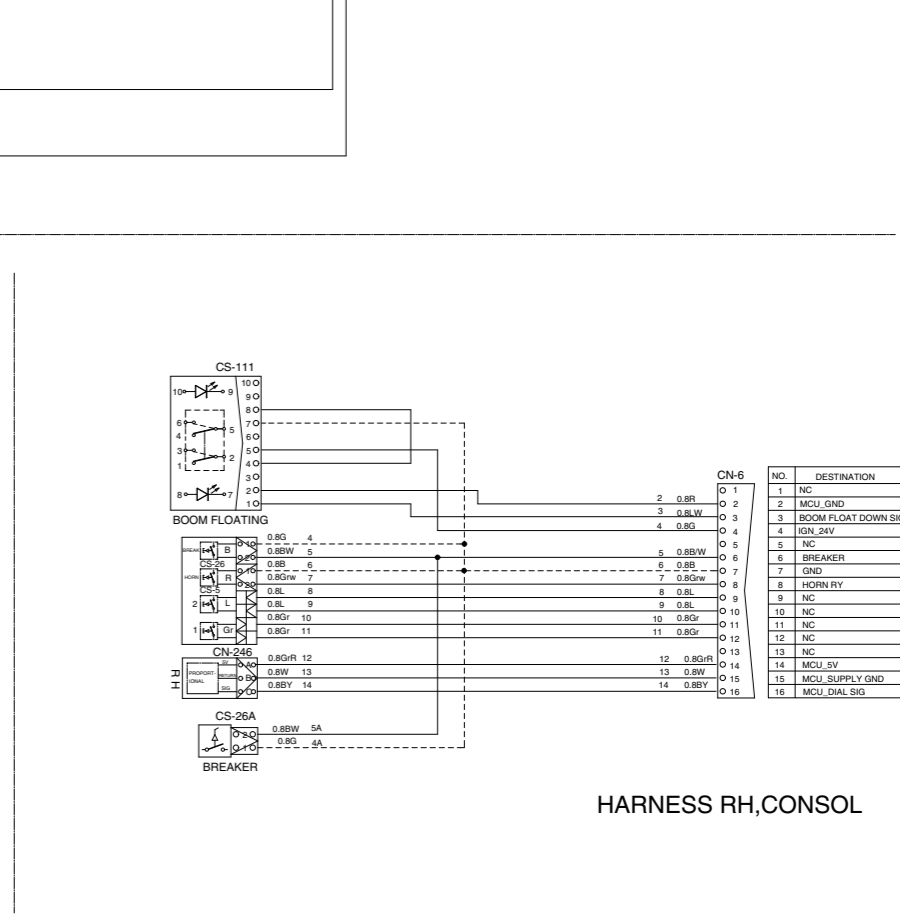
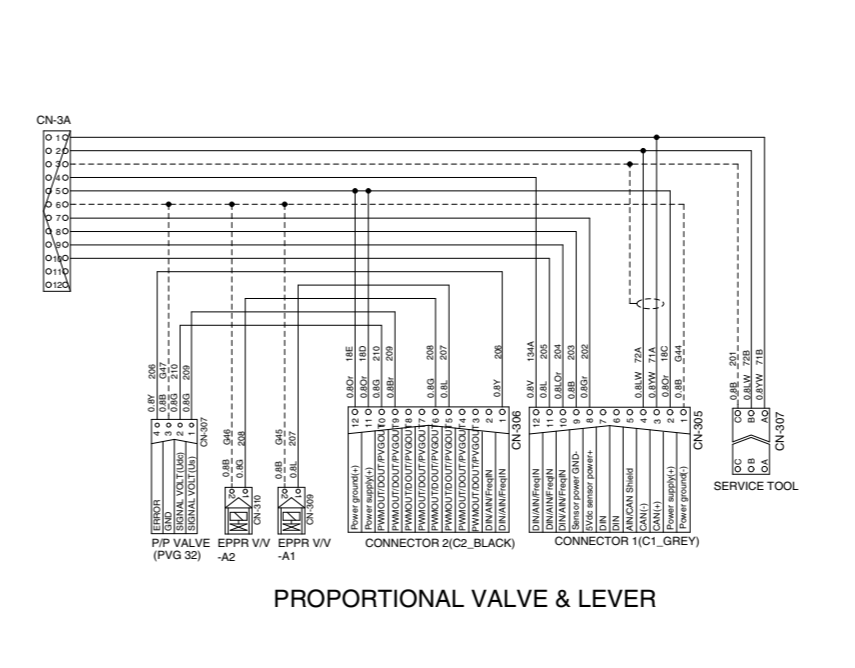
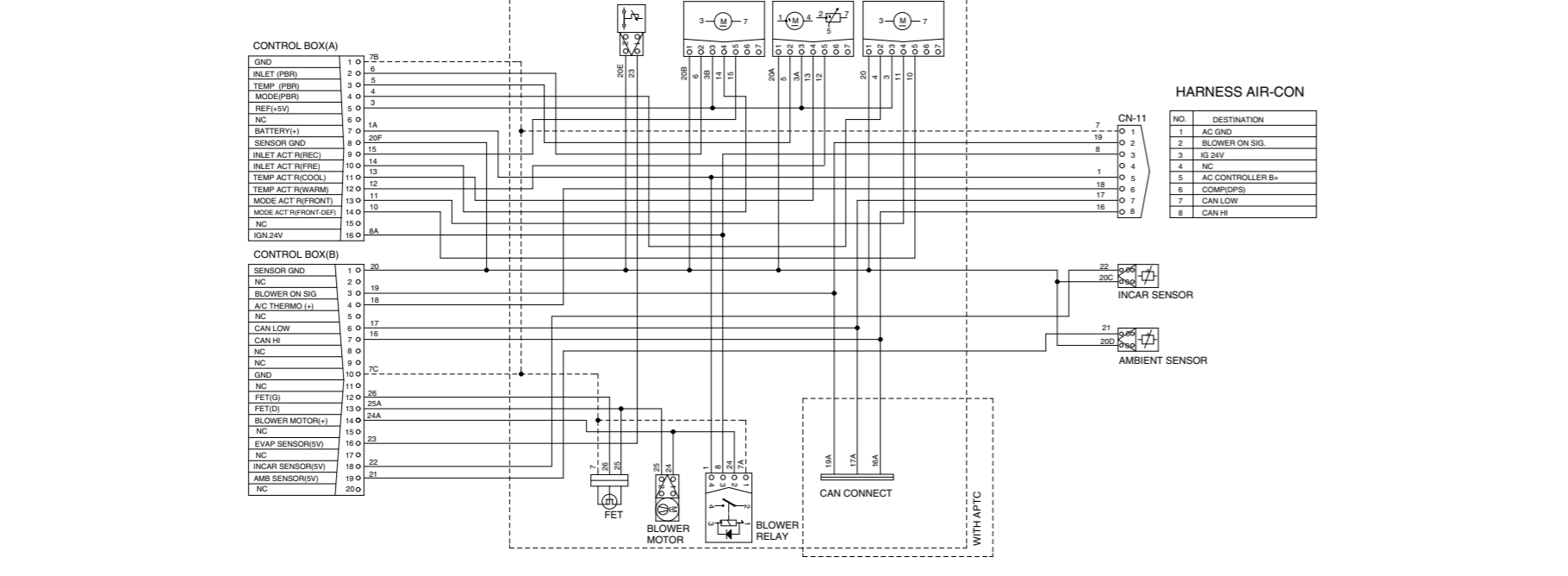
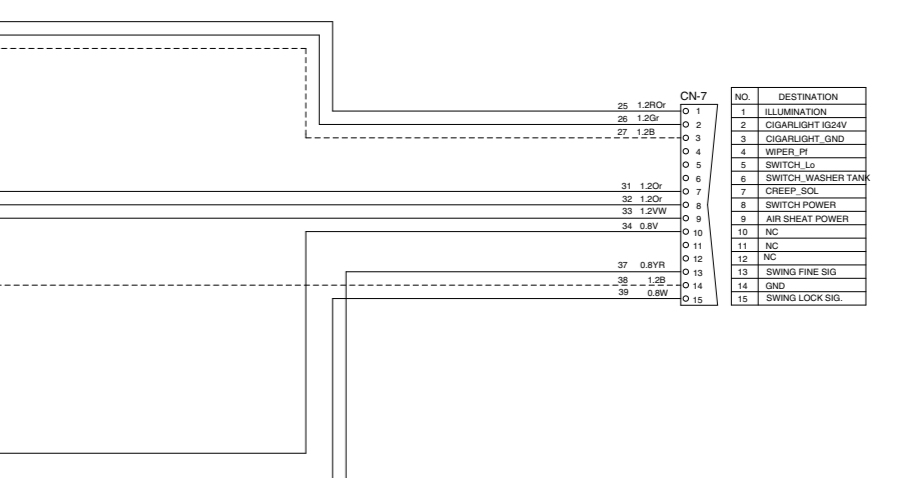
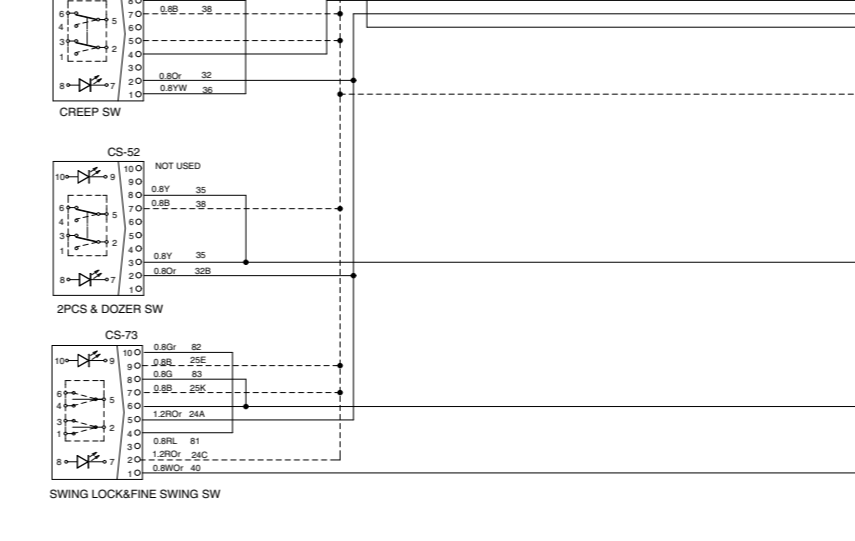
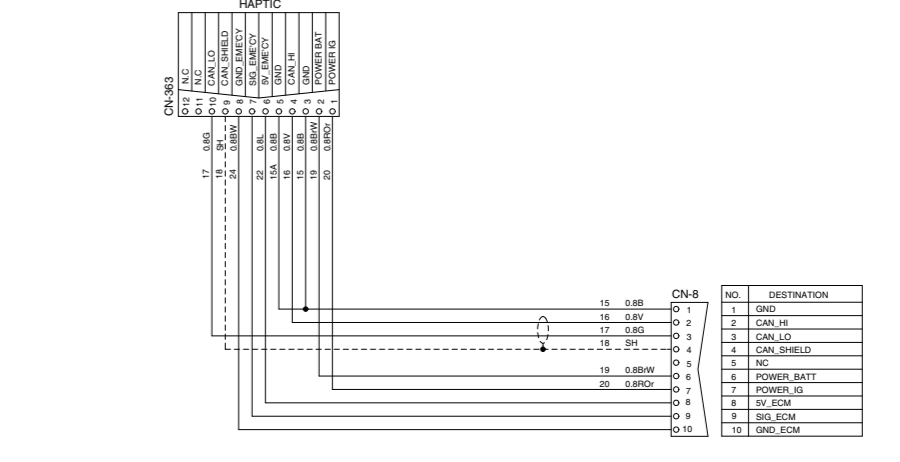
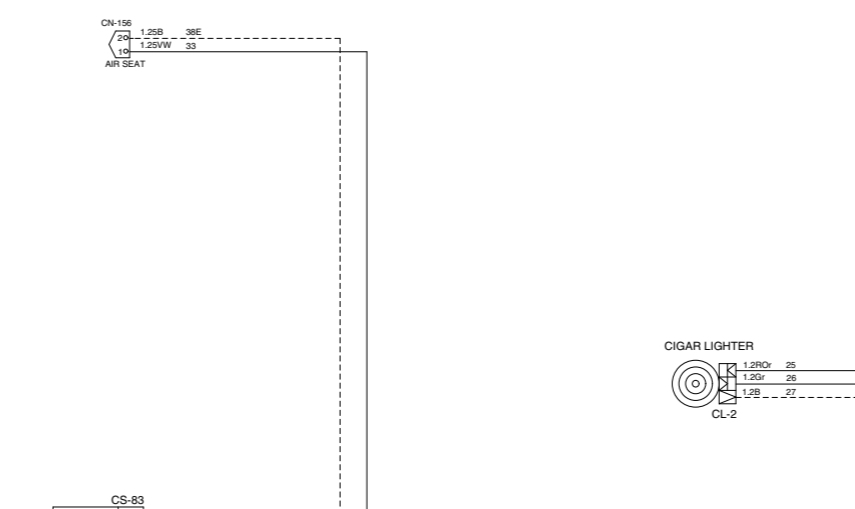
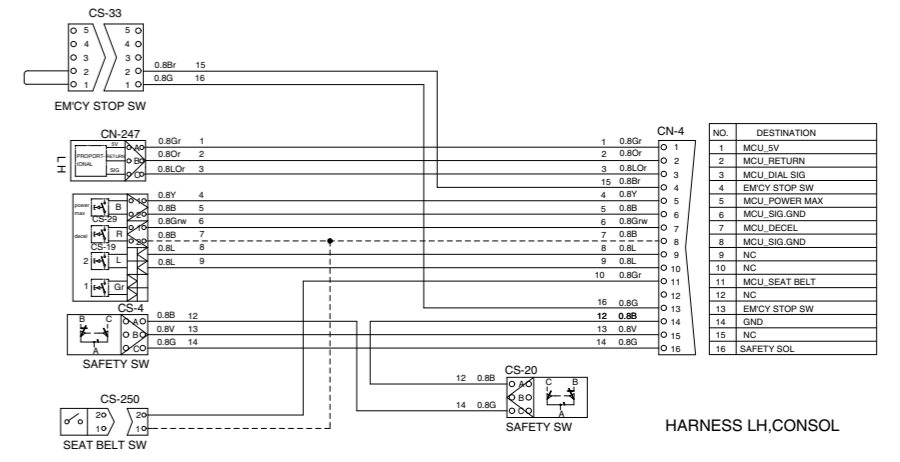
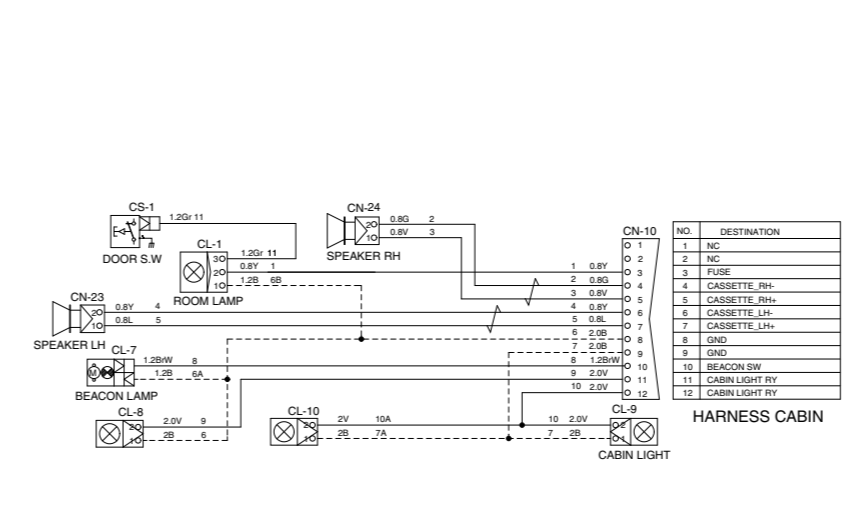
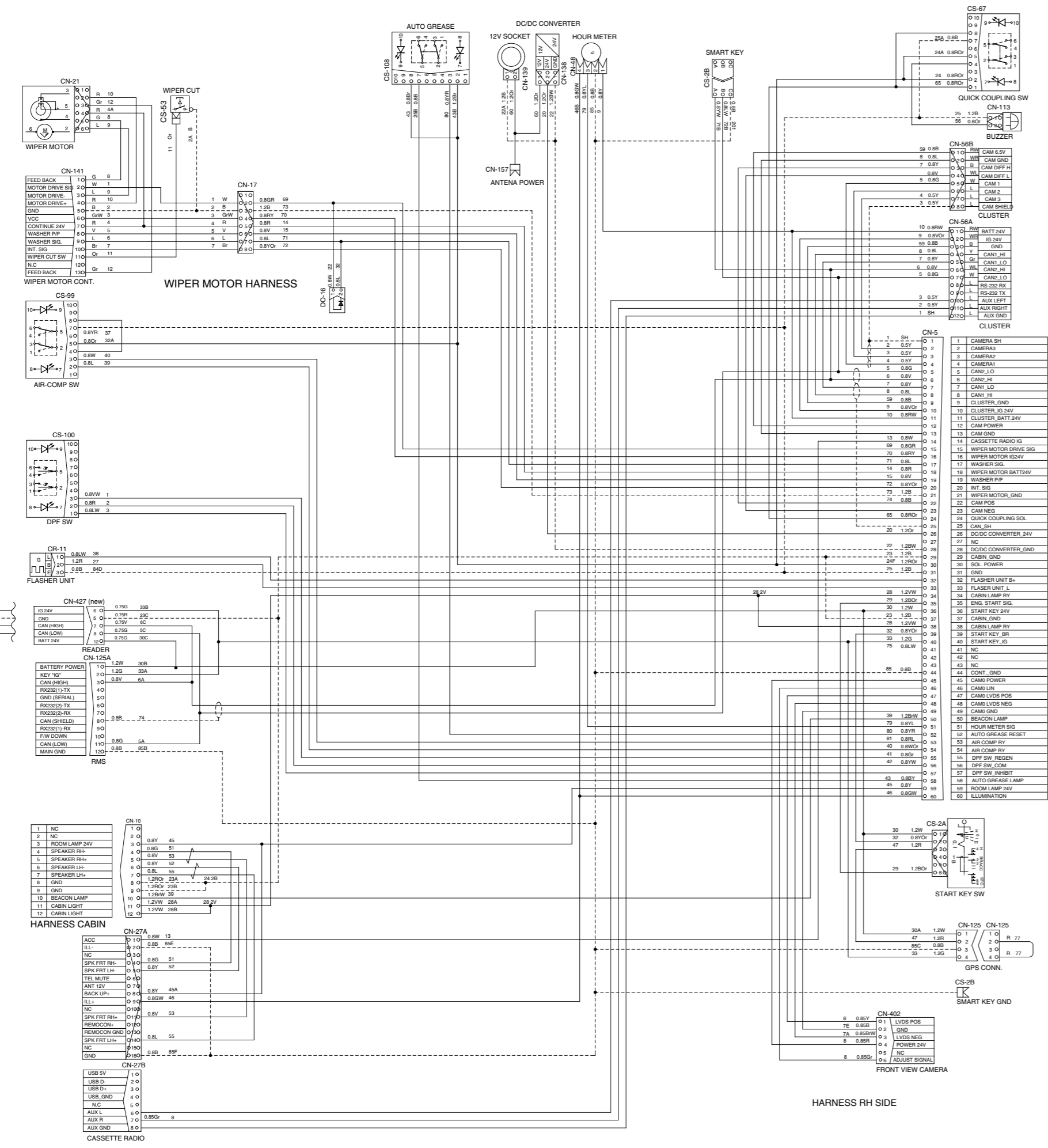



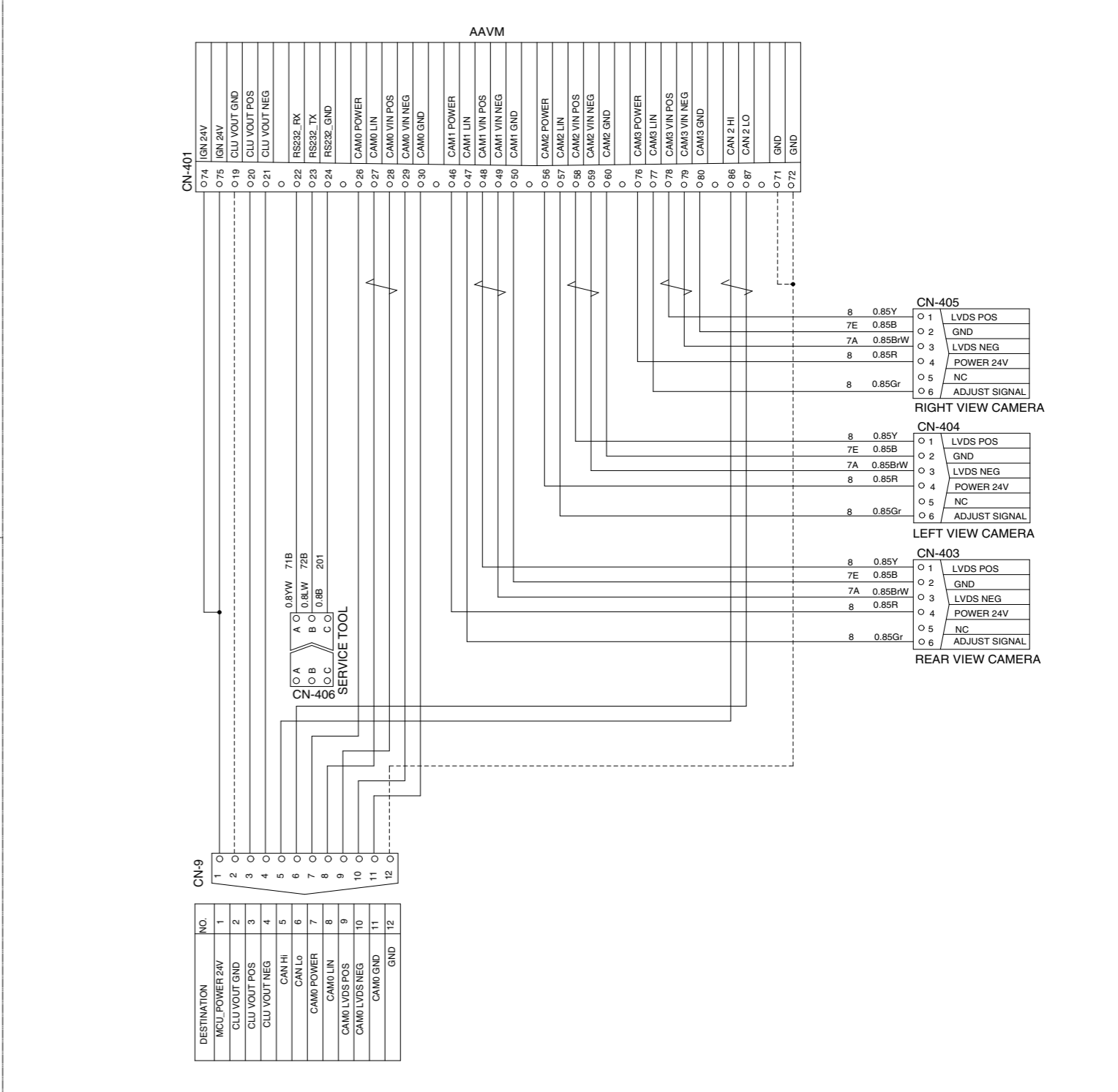
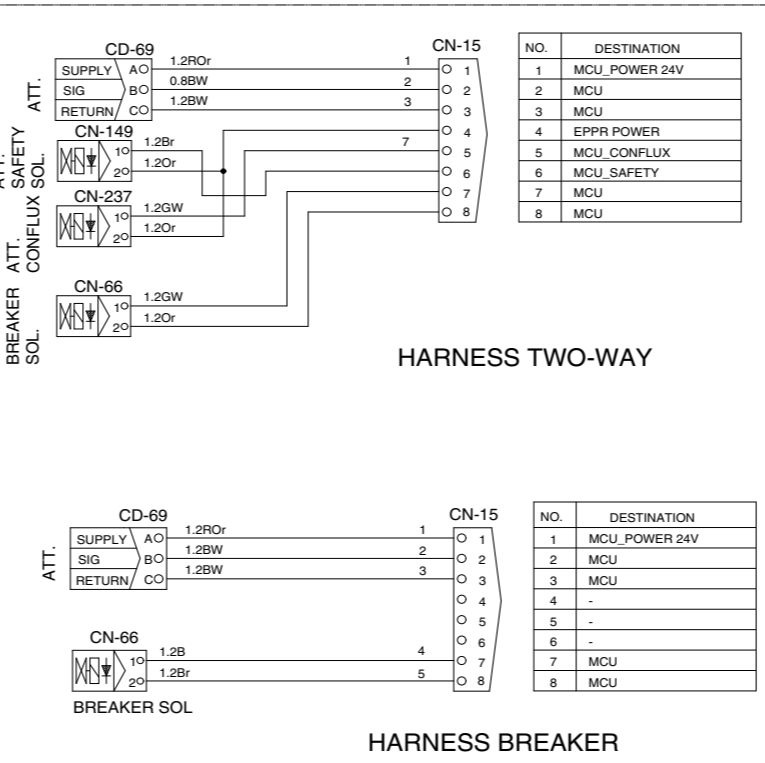
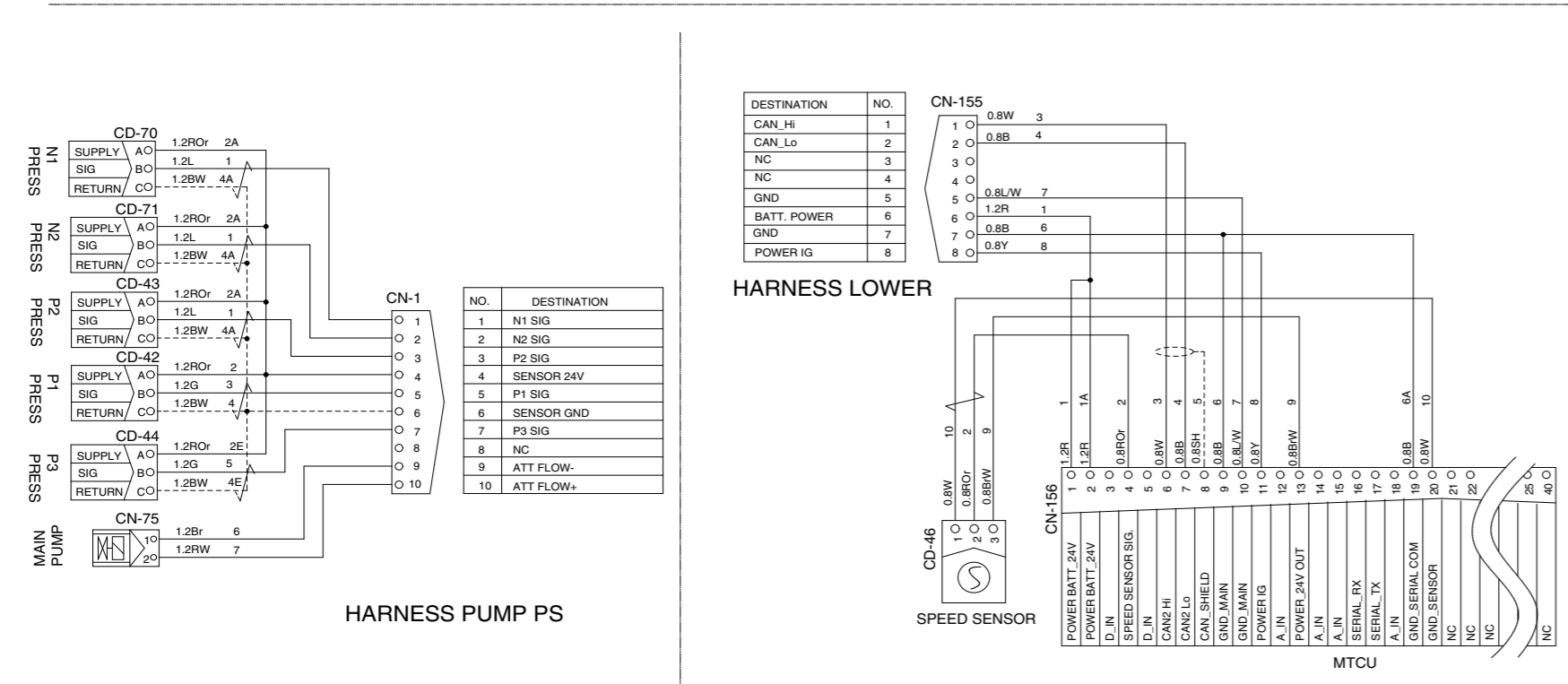
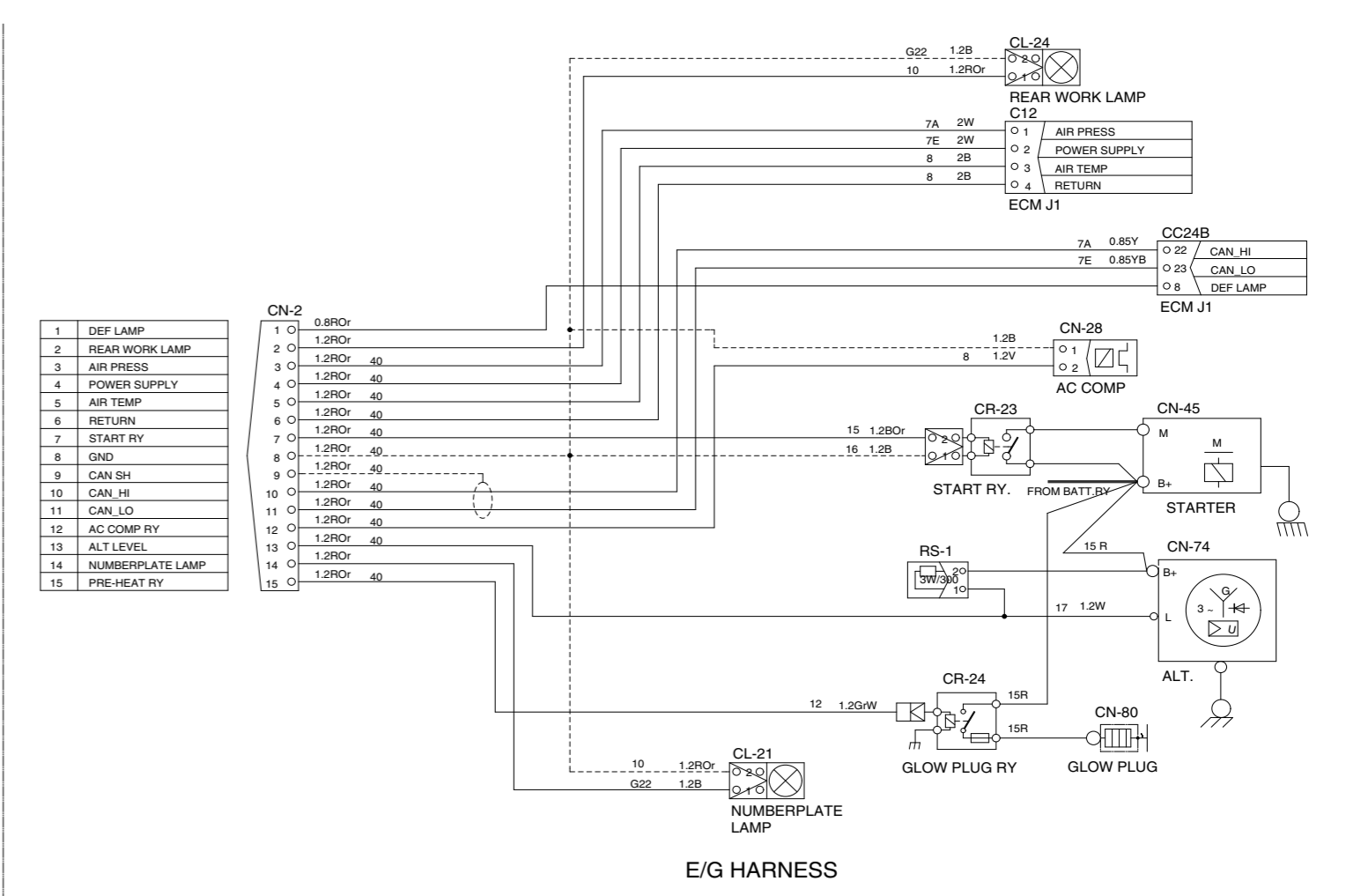
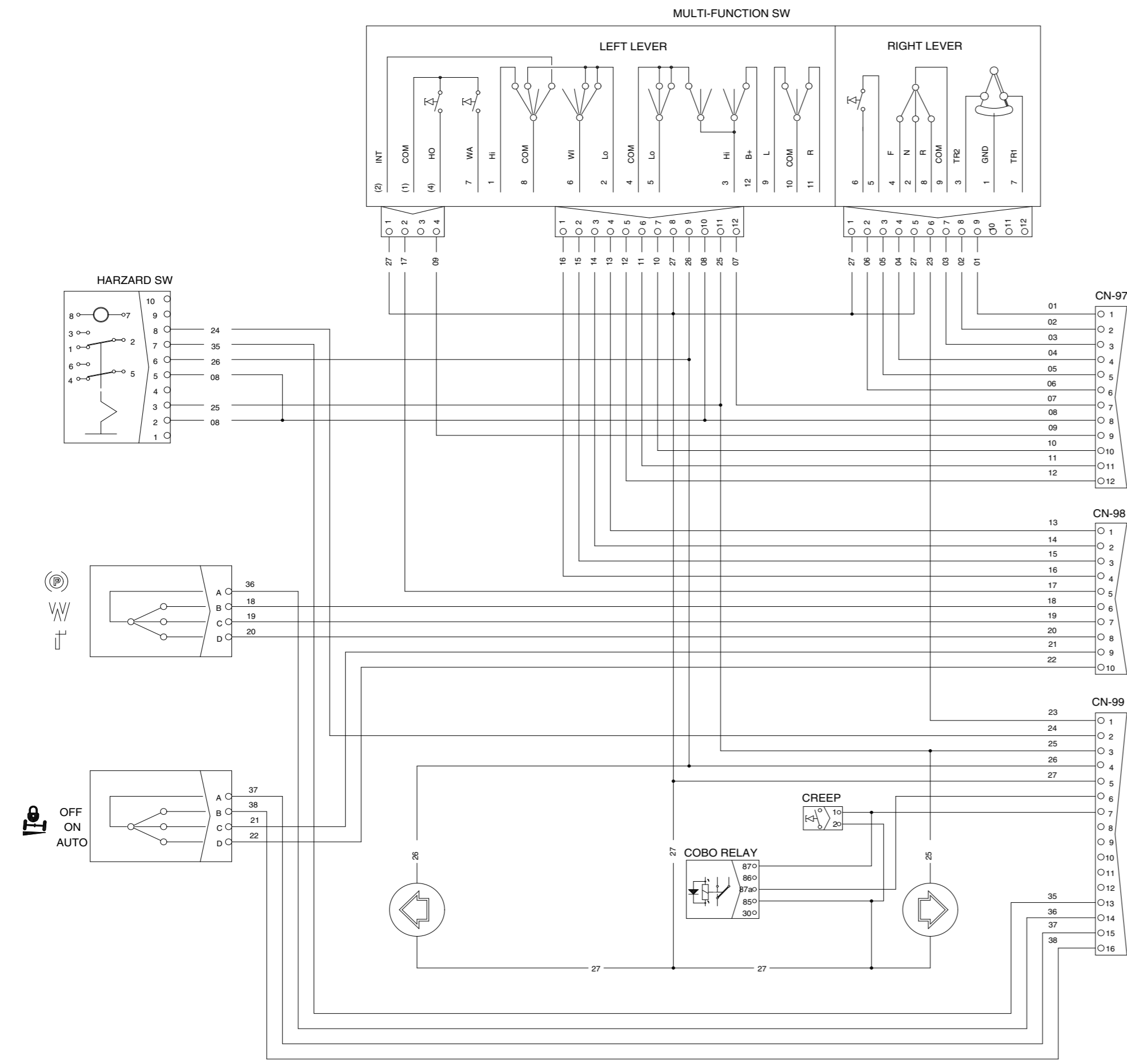

**MEMORANDUM**

# 1. POWER CIRCUIT

The negative terminal of battery is grounded to the machine chassis.

When the start switch is in the OFF position, the current flows from the positive battery terminal as shown below.

## 1) OPERATING FLOW

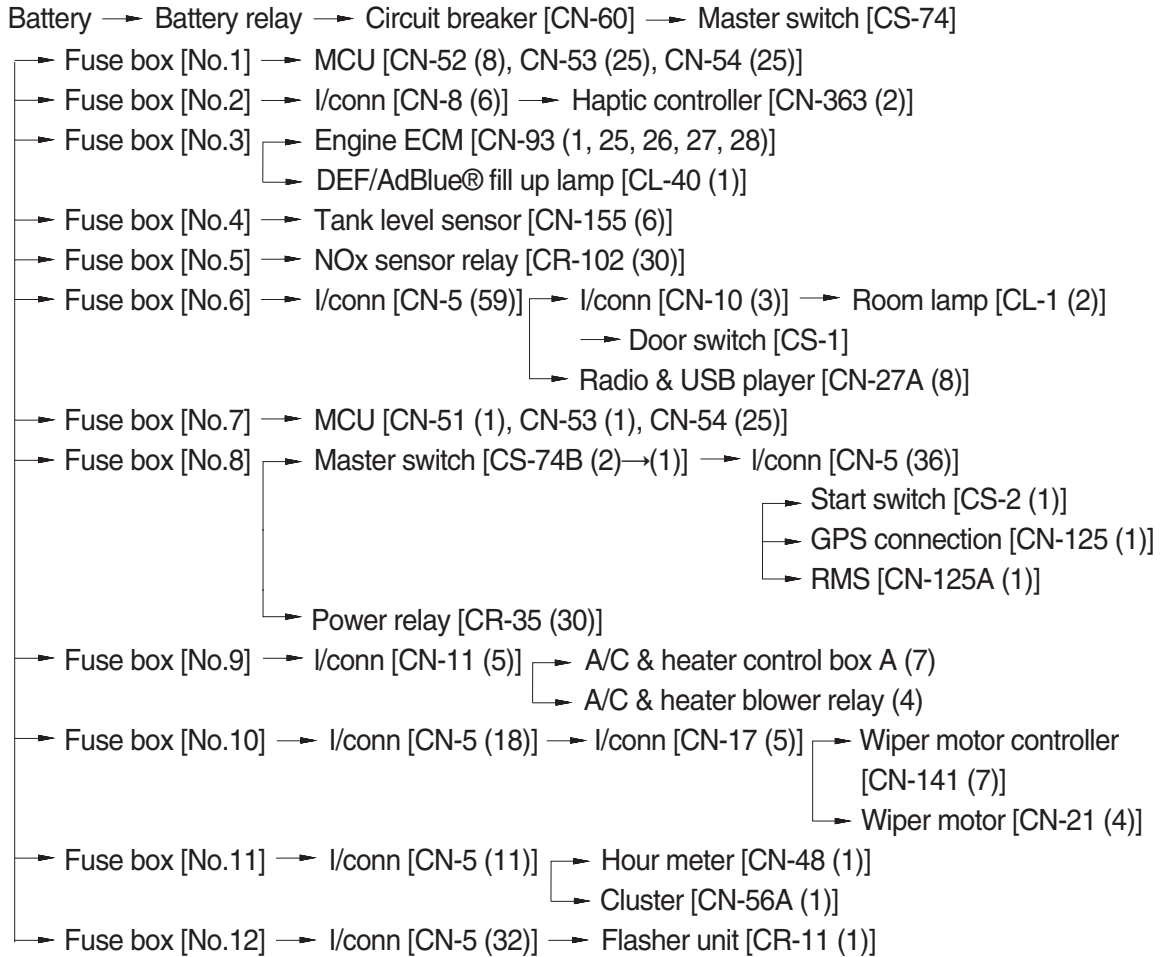

I/conn : Intermediate connector

## 2) CHECK POINT

Engine	Start switch	Check point	Voltage
OFF	OFF	① - GND (battery 1EA)	10~12.5 V
		② - GND (battery 2EA)	20~25 V
		③ - GND (battery relay 2EA)	20~25 V
		④ - GND (circuit breaker)	20~25 V

※ GND : Ground

# POWER CIRCUIT

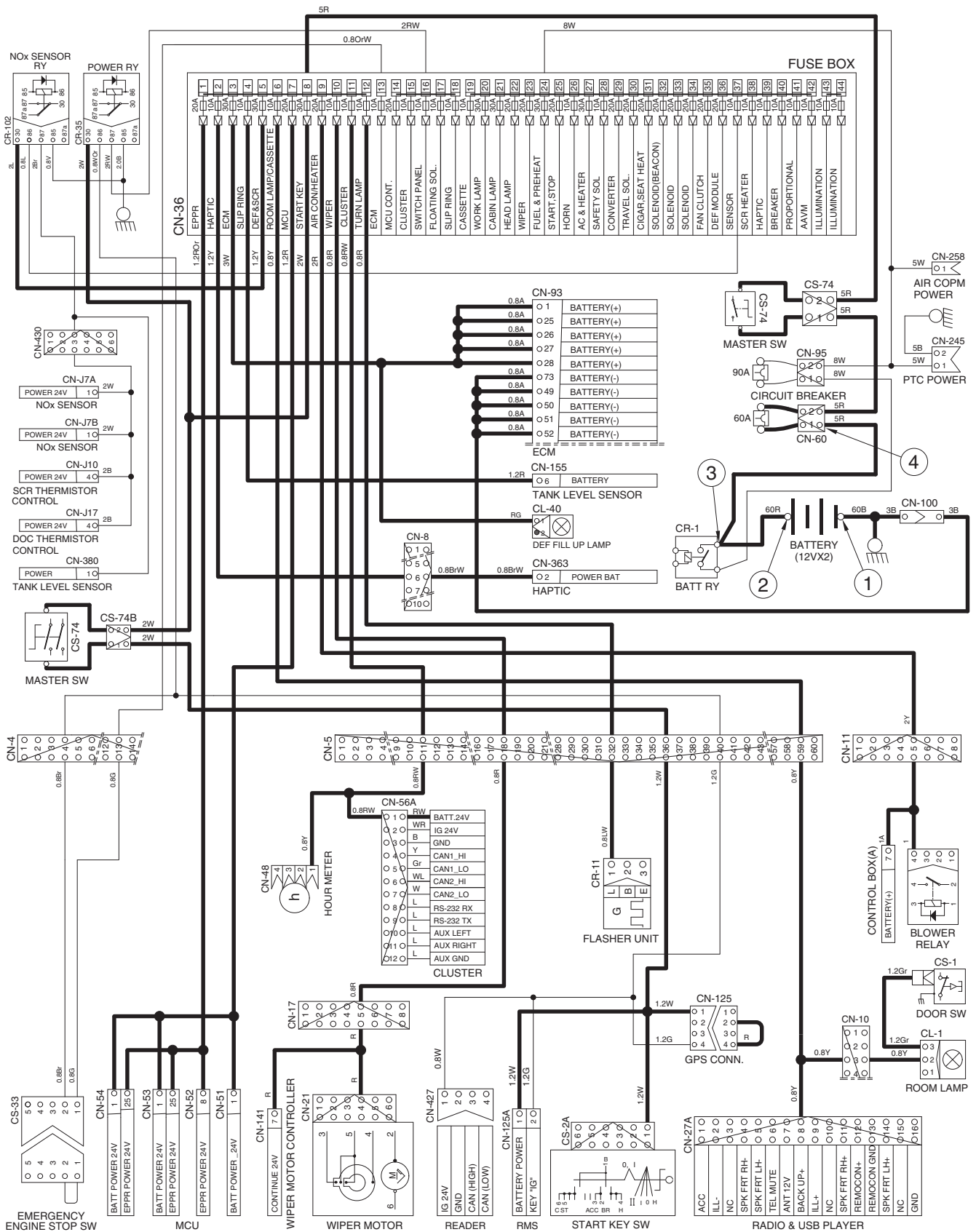

140WF4EL03



# STARTING CIRCUIT

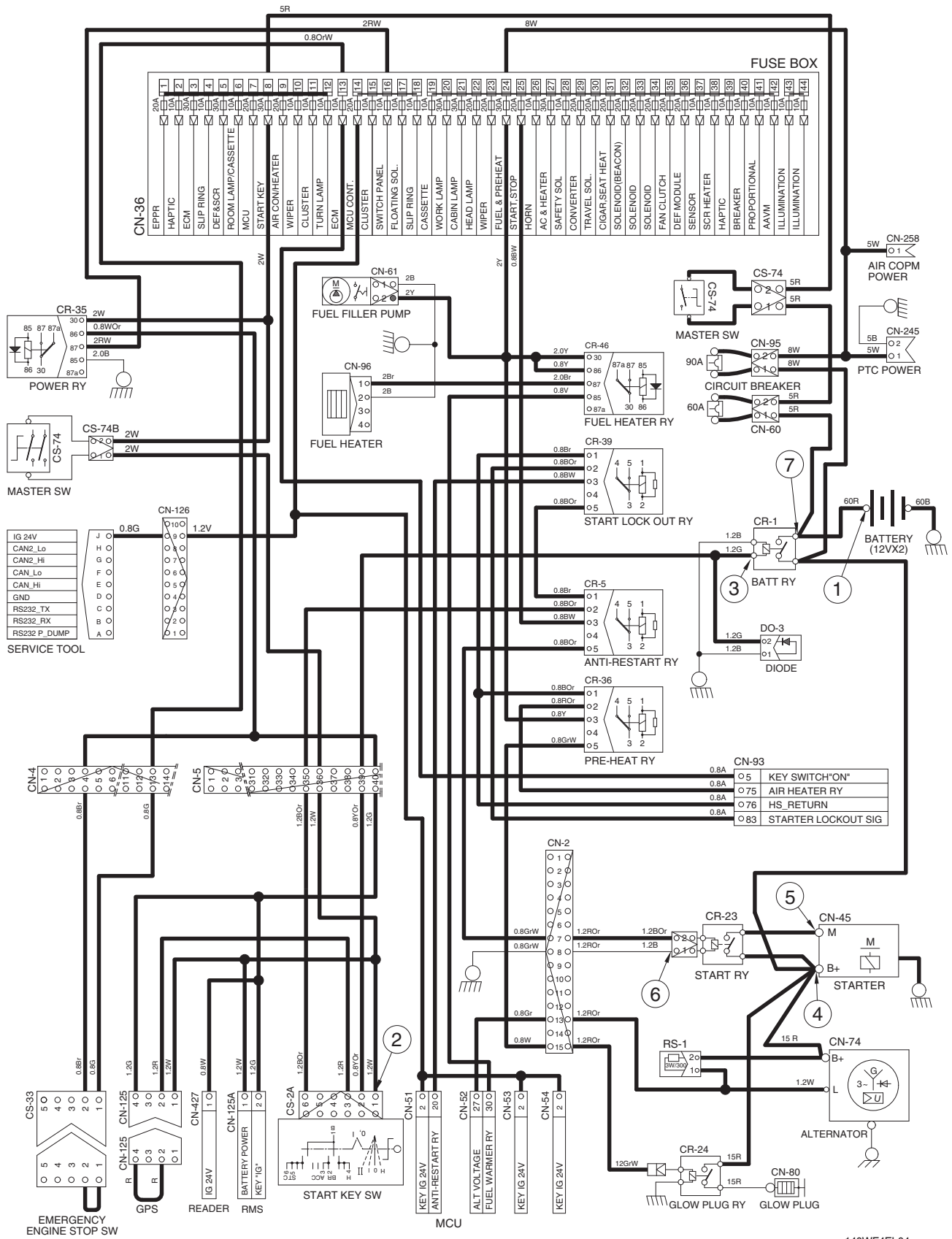

140WF4EL04

### 3. CHARGING CIRCUIT

When the starter is activated and the engine is started, the operator releases the key switch to the ON position.

Charging current generated by operating alternator flows into the battery through the battery relay [CR-1].

The current also flows from alternator to each electrical component and controller through the fuse box.

#### 1) OPERATING FLOW

##### (1) Warning flow

Alternator [CN-74 (L)] → I/conn [CN-2 (13)] → MCU alternator level [CN-52 (27)] → Cluster charging warning lamp (via CAN interface)

##### (2) Charging flow

Alternator [CN-74 (B<sup>+</sup>)] → Starter [CN-45 (B<sup>+</sup>)] → Battery relay (M8)

- Battery (+) terminal
- Circuit breaker [CN-60] → Master switch [CS-74] → Fuse box [No. 1~12]
- Circuit breaker [CN-95] → Fuse box [No. 19~44]

#### 2) CHECK POINT

Engine	Start switch	Check point	Voltage
Run	ON	① - GND (battery voltage) ② - GND (battery relay) ③ - GND (alternator B <sup>+</sup> terminal) ④ - GND (alternator L terminal) ⑤ - GND (MCU)	20~30 V

※ GND : Ground

# CHARGING CIRCUIT

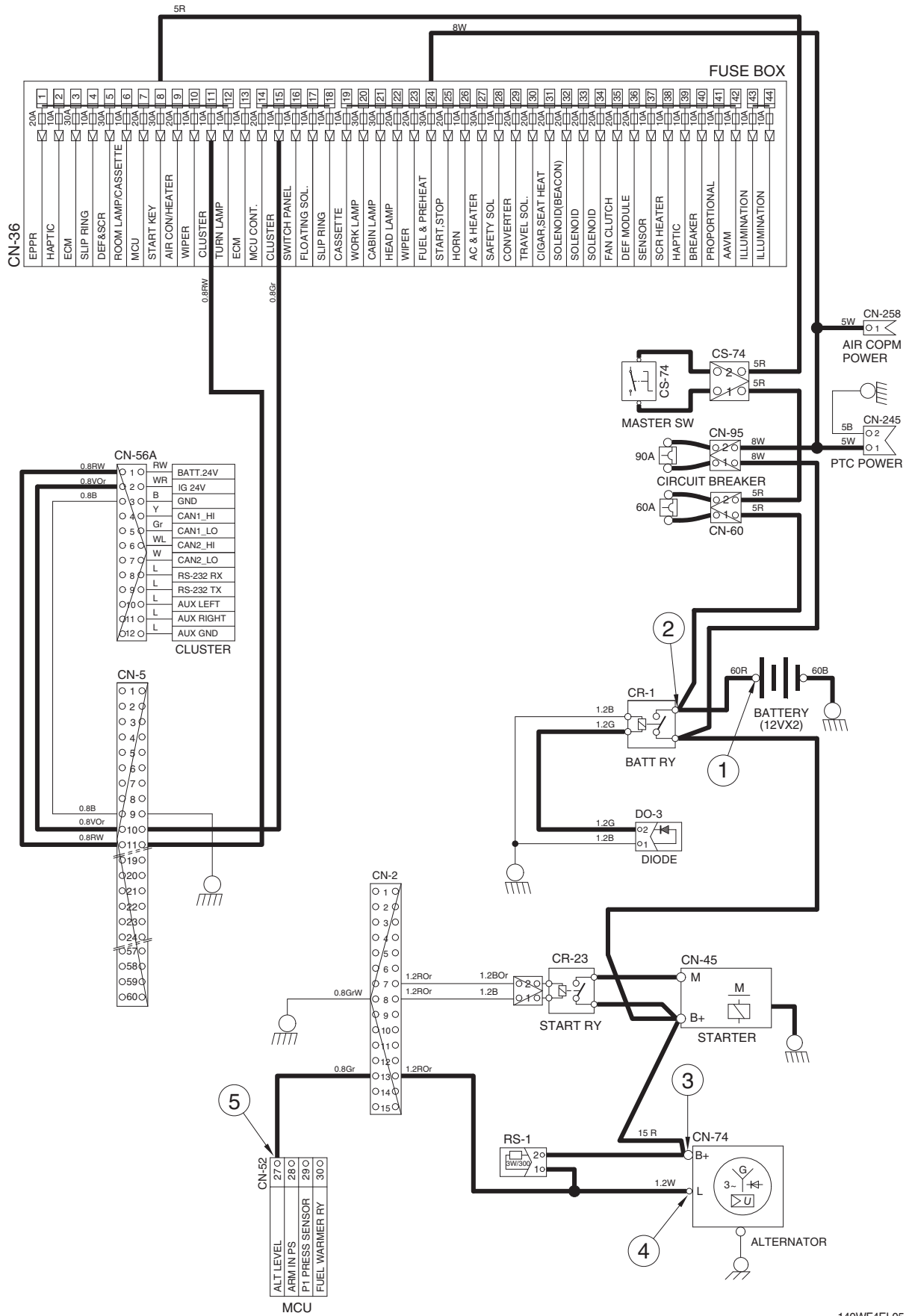



## 4. HEAD AND WORK LIGHT CIRCUIT

### 1) OPERATING FLOW

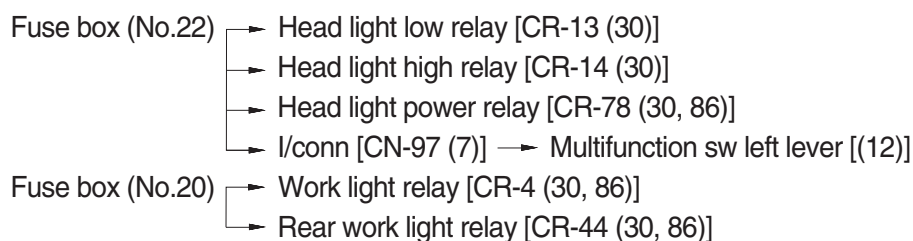

#### (1) Head light switch ON

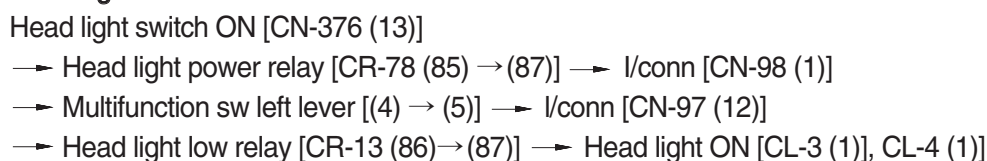

#### (2) Work light switch ON

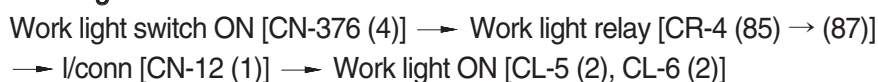

#### (3) Rear work light switch ON

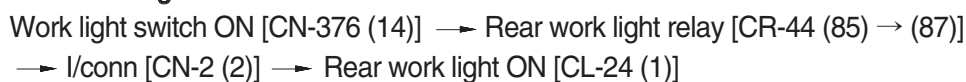

### 2) CHECK POINT

Engine	Start switch	Check point	Voltage
STOP	ON	① - GND (fuse box) ② - GND (switch power output) ③ - GND (head light relay) ④ - GND (head light) ⑤ - GND (fuse box) ⑥ - GND (switch power output) ⑦ - GND (work light relay) ⑧ - GND (work light) ⑨ - GND (switch power output) ⑩ - GND (rear work light relay) ⑪ - GND (rear work light)	20~30 V

※ GND : Ground



## 5. BEACON LAMP AND CAB LIGHT CIRCUIT

### 1) OPERATING FLOW

Fuse box (No.32) → Beacon lamp relay [CR-85 (2, 3)]

Fuse box (No.21) → Cab light relay [CR-9 (30, 86)]

#### (1) Beacon lamp switch ON

Beacon lamp switch ON [CN-376 (15)] → Beacon light relay [CR-85 (1) → (5)]

→ I/conn [CN-5 (50)] → I/conn [CN-10 (10)] → Beacon lamp ON [CL-7]

#### (2) Cab light switch ON

Cab light switch ON [CN-376 (5)] → Cab lamp relay [CR-9 (85) → (87)]

→ I/conn [CN-5 (34, 38)] → I/conn [CN-10 (11)] → Cab light ON [CL-8 (2)]

→ I/conn [CN-10 (12)] → Cab light ON [CL-9 (2), CL-10 (2)]

### 2) CHECK POINT

Engine	Start switch	Check point	Voltage
STOP	ON	① - GND (fuse box) ② - GND (beacon lamp relay) ③ - GND (switch power output) ④ - GND (beacon lamp) ⑤ - GND (fuse box) ⑥ - GND (cab light relay) ⑦ - GND (switch power output) ⑧ - GND (cab light)	20~25 V

※ GND : Ground

# BEACON LAMP AND CAB LIGHT CIRCUIT

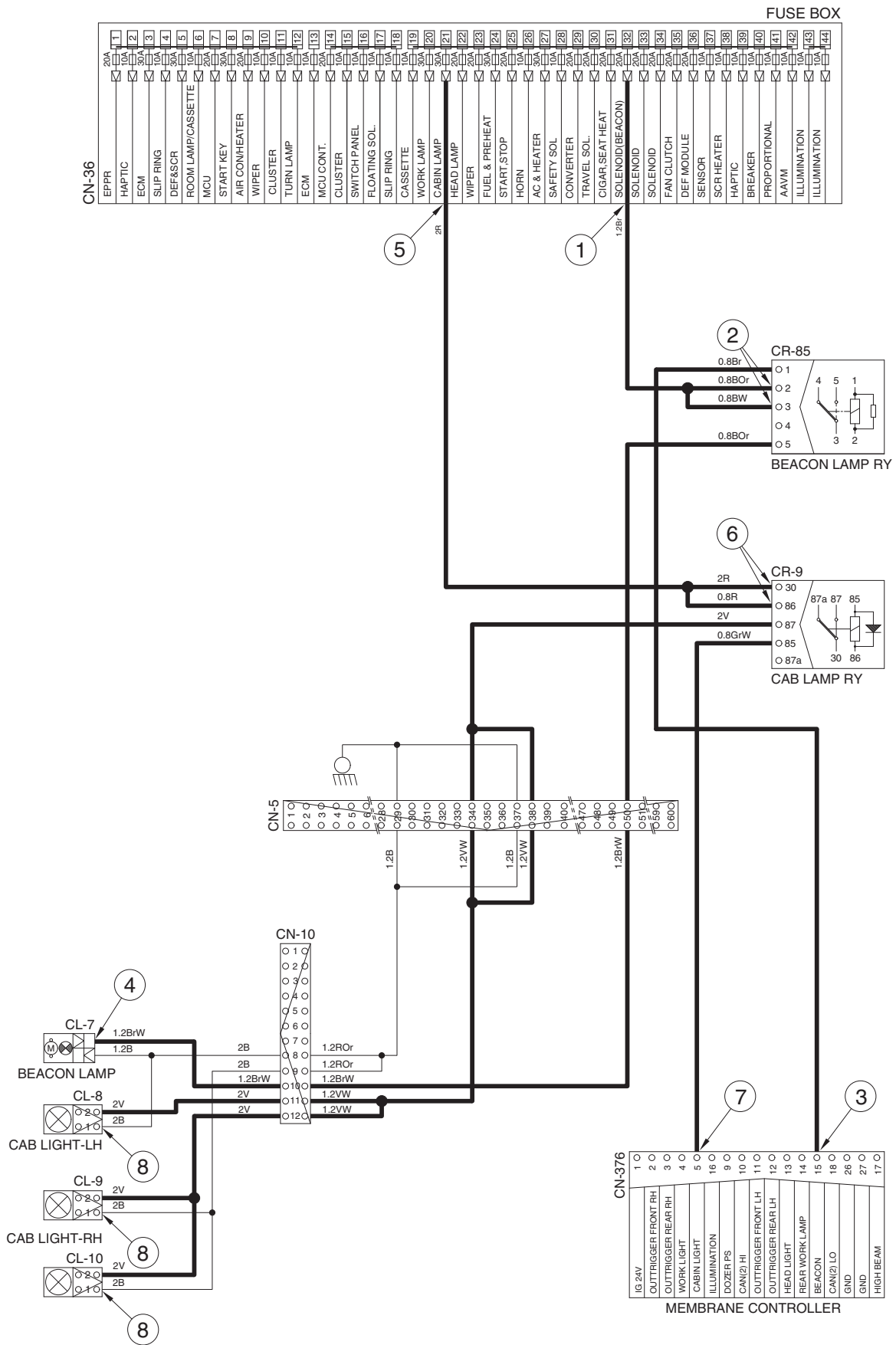

140WF4EL07



# WIPER AND WASHER CIRCUIT

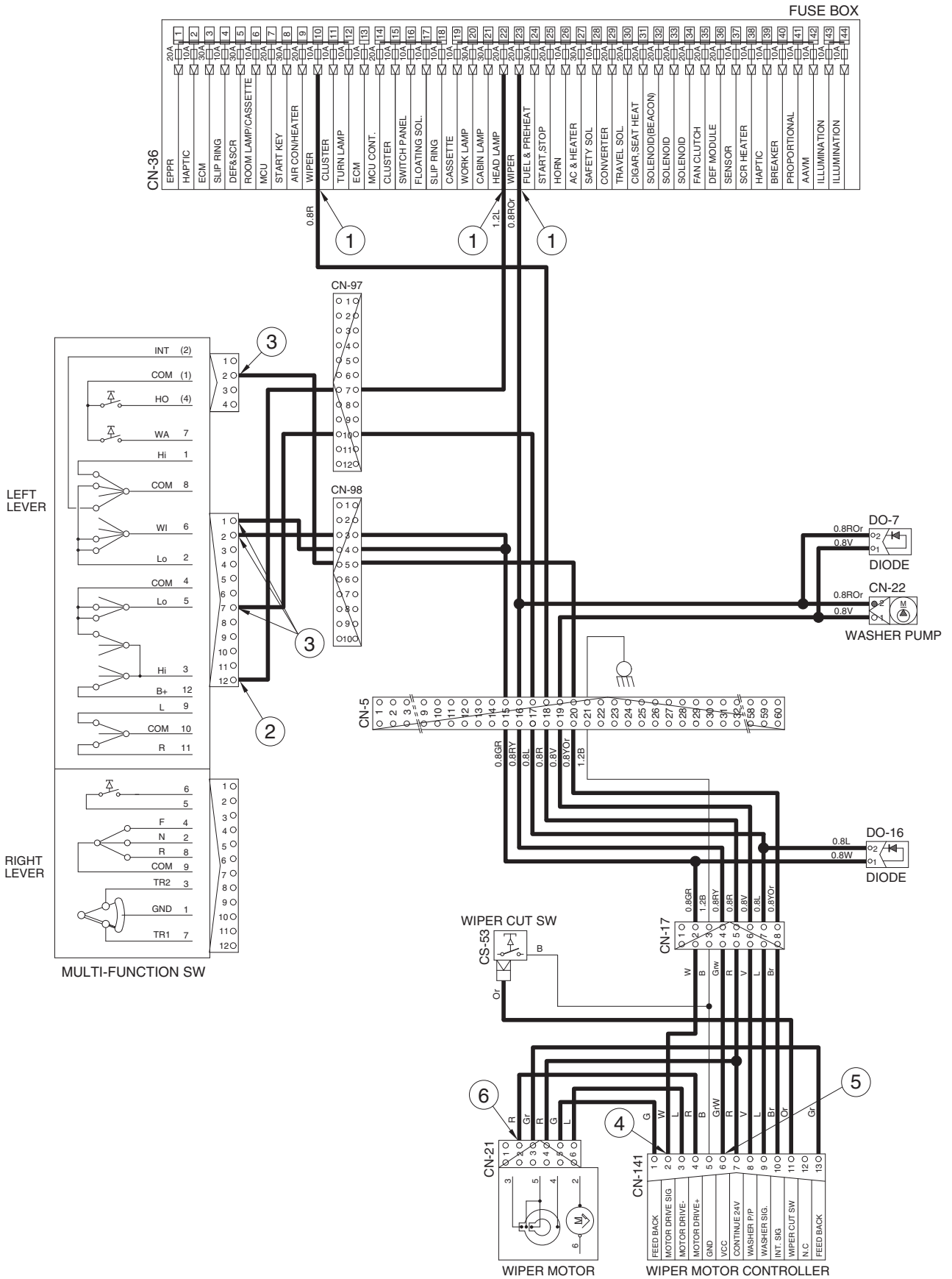

140WF4EL08

# ILLUMINATION CIRCUIT

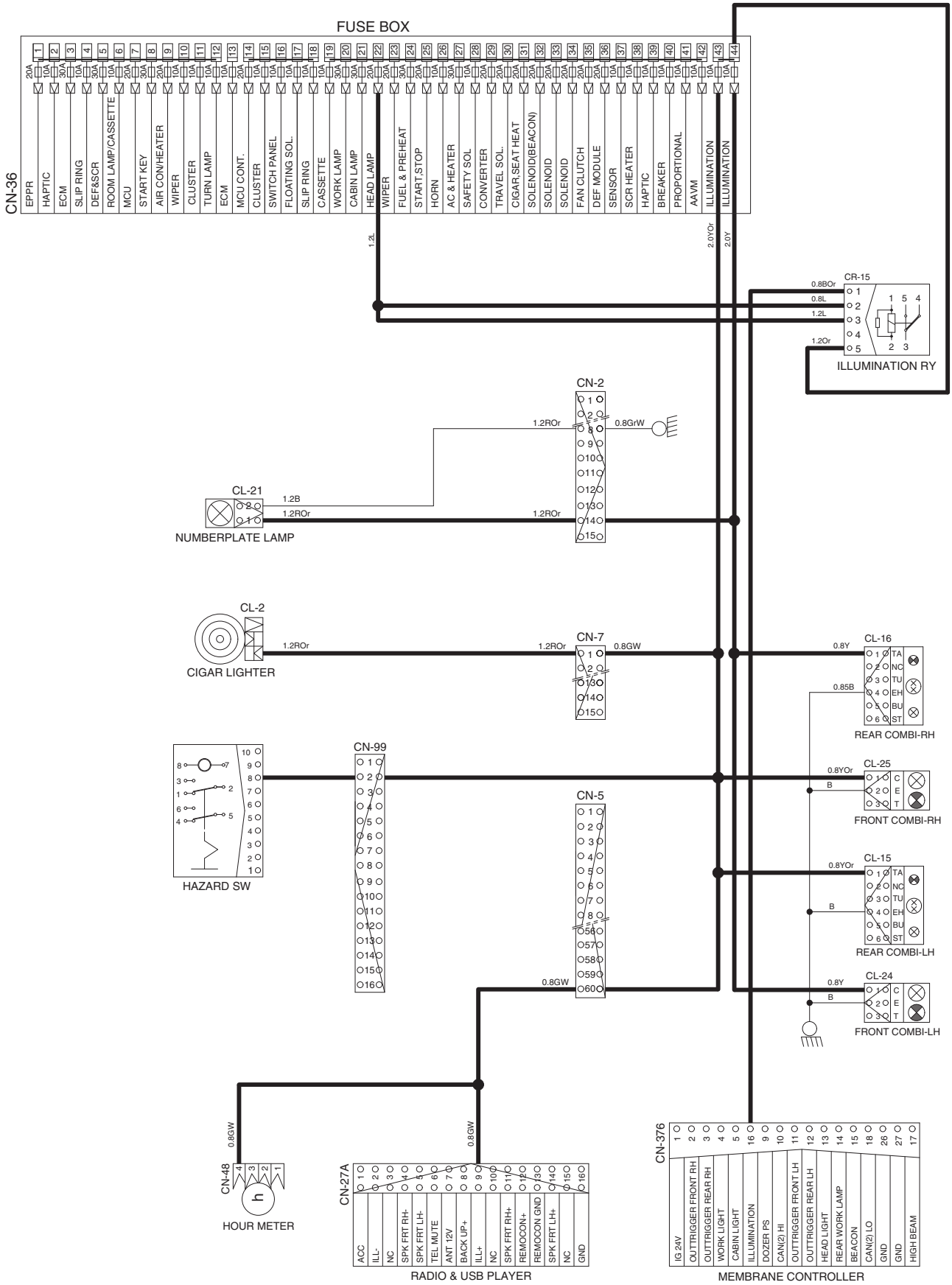





# CONTROLLER CIRCUIT

FUSE BOX

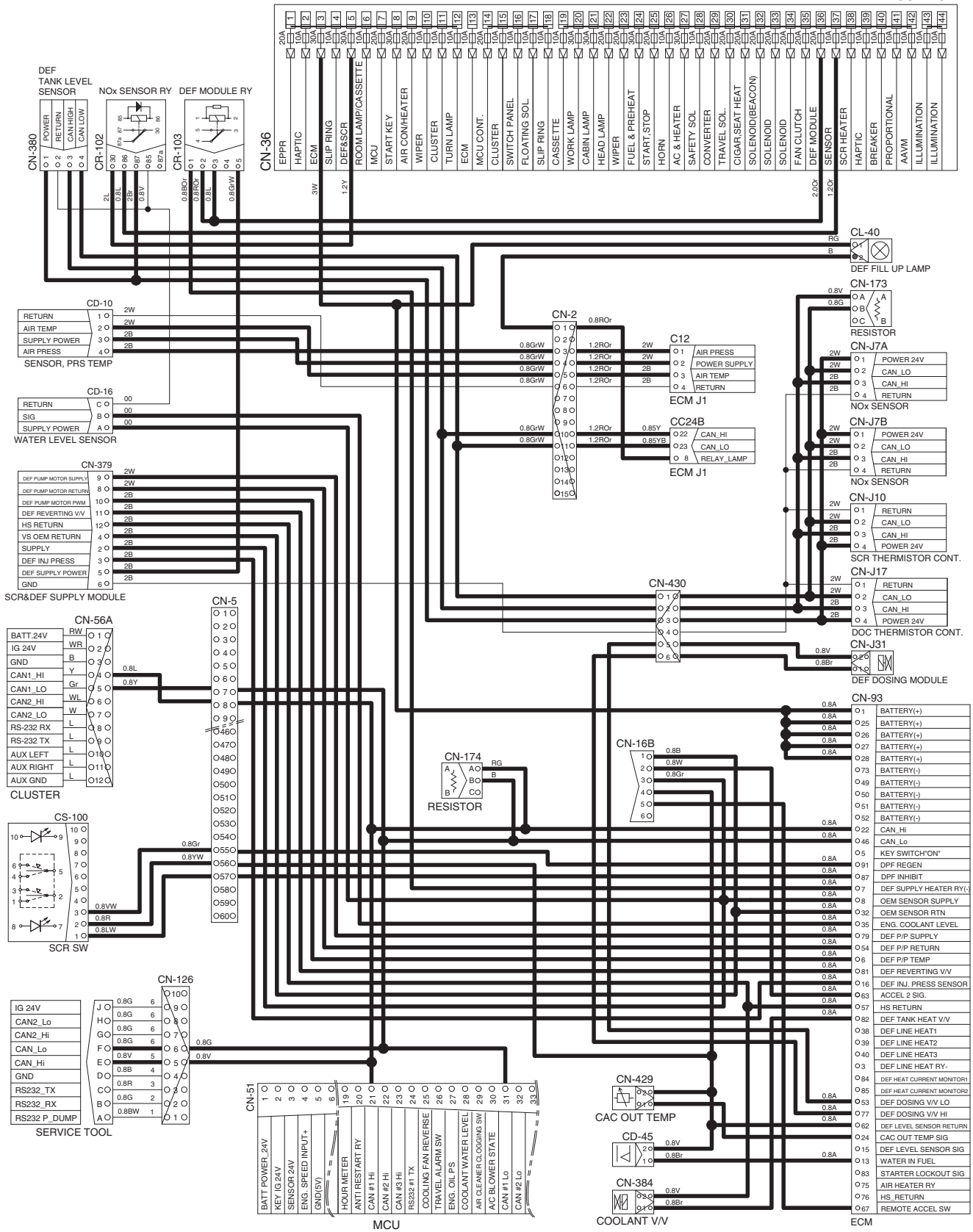

140WF4EL11

# MONITORING CIRCUIT

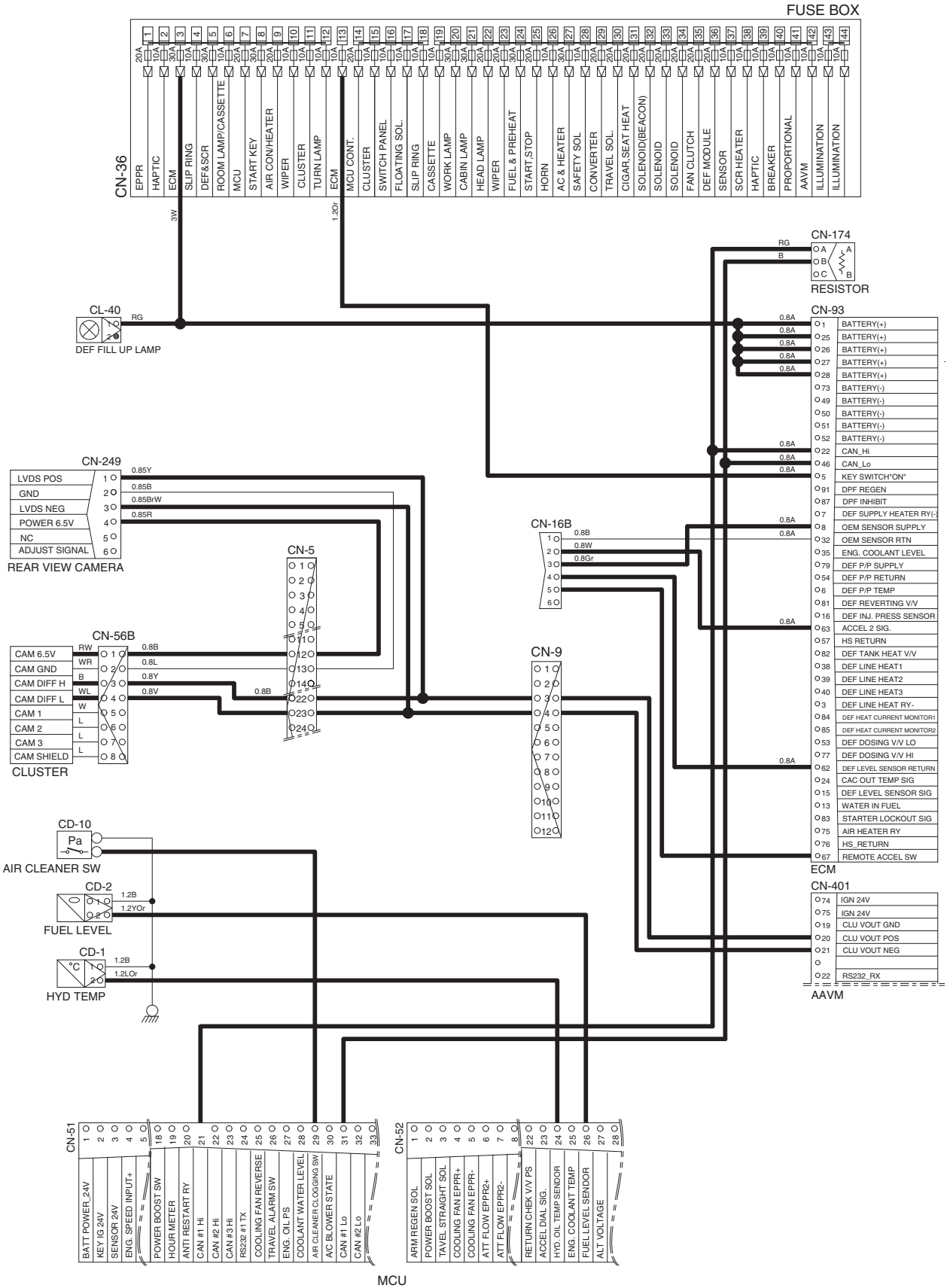

# ELECTRIC CIRCUIT FOR HYDRAULIC (1/2)

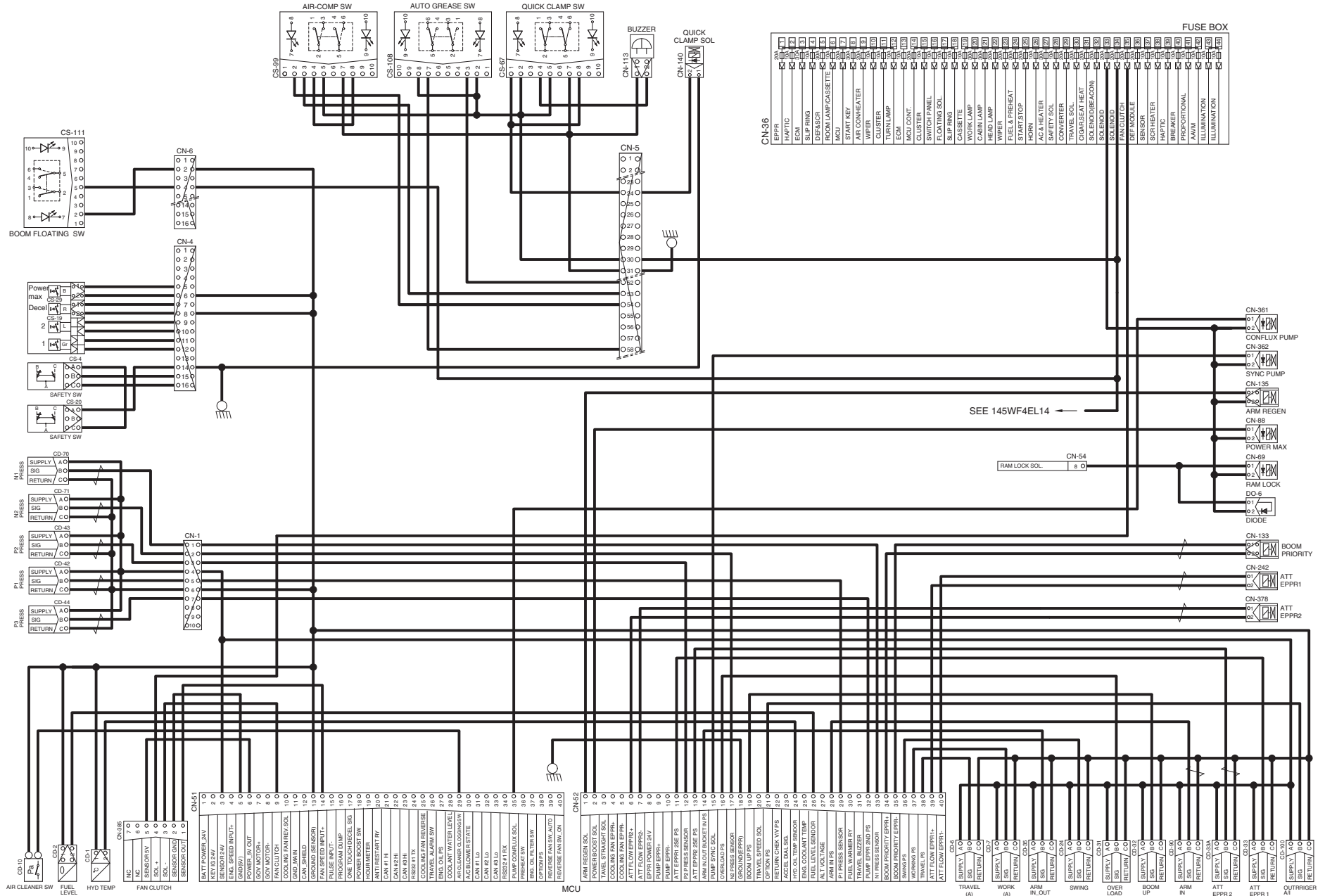

SEE 145WF4EL14

RAM LOCK SOL CN-54

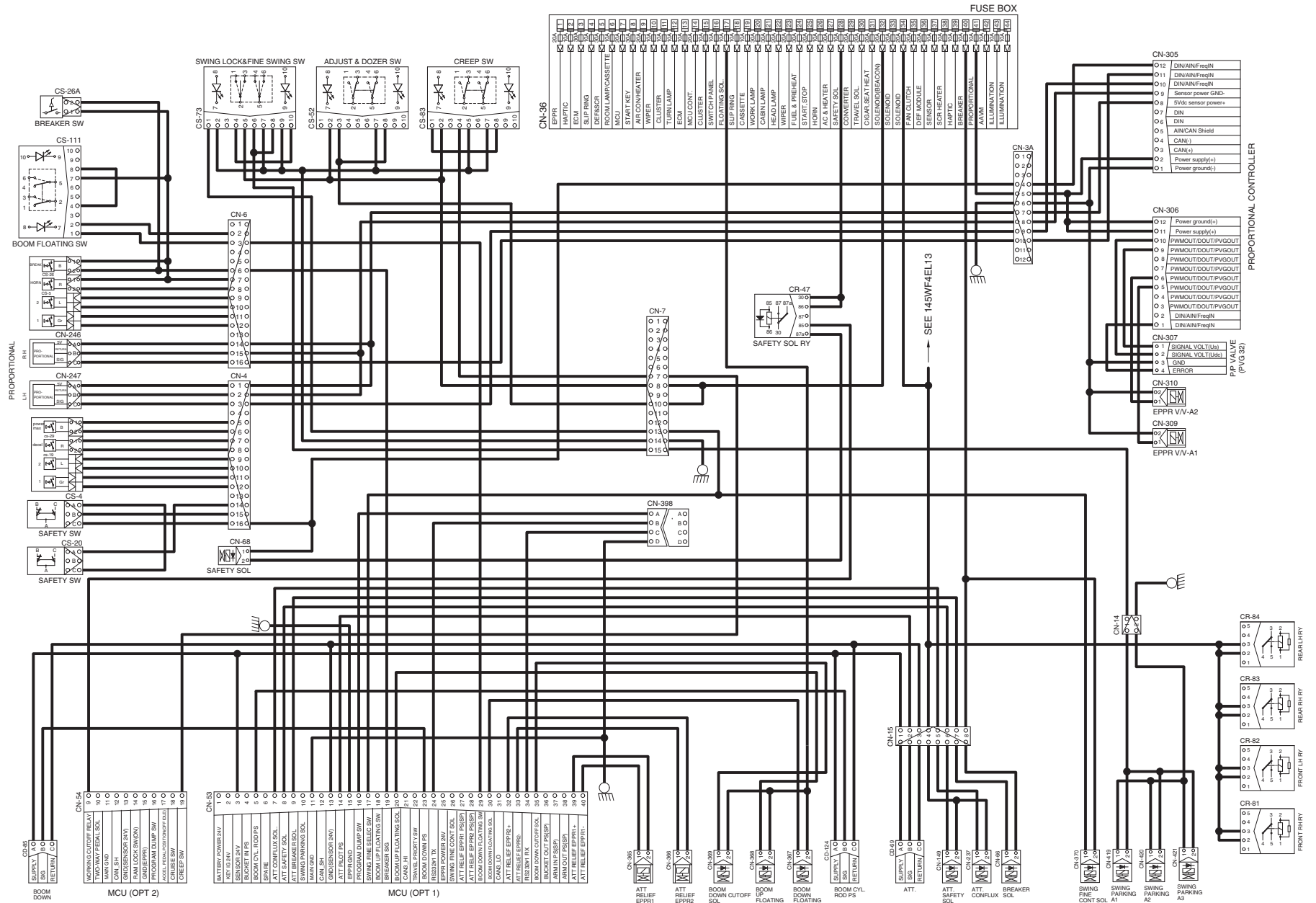

# ELECTRIC CIRCUIT FOR HYDRAULIC (2/2)

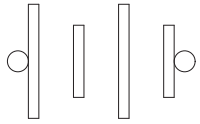
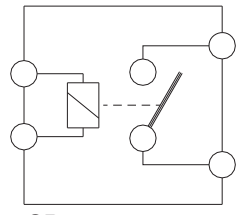
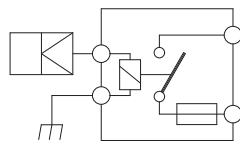
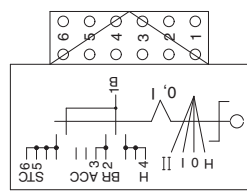

## GROUP 3 ELECTRICAL COMPONENT SPECIFICATION

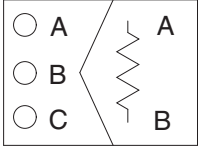
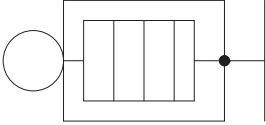
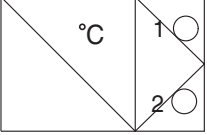
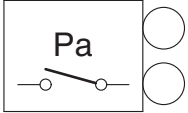
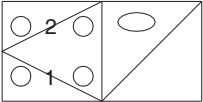
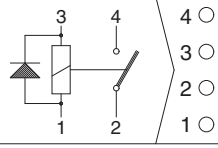
Part name	Symbol	Specifications	Check						
Battery		12V × 100Ah (2EA)	※ Check specific gravity 1.280 over : Over charged 1.280 ~ 1.250 : Normal 1.250 below : Recharging						
Battery relay	 <p style="text-align: center;">CR-1</p>	Rated load : 24V 100A (continuity) 1000A (30 seconds)	※ Check coil resistance(M4 to M4) Normal : About 50 Ω ※ Check contact Normal : ∞ Ω						
Glow plug relay	 <p style="text-align: center;">CR-24</p>	24V 200A	※ Check contact Normal : 0.942 Ω (For terminal 1-GND)						
Start key	 <p style="text-align: center;">CS-2A</p>	B-BR : 24V 1A B-ACC : 24V 10A B-ST : 24V 40A	※ Check contact OFF : ∞ Ω (for each terminal) ON : 0 Ω (for terminal 1-3 and 1-2) START : 0 Ω (for terminal 1-6)						
Pressure sensor	<table border="1" style="margin-left: auto; margin-right: auto;"> <tr><td>○ A</td><td>SUPPLY</td></tr> <tr><td>○ B</td><td>SIG</td></tr> <tr><td>○ C</td><td>RETURN</td></tr> </table> <p>CD-3 CD-5 CD-6 CD-7 CD-16 CD-24 CD-31 CD-32 CD-35 CD-38 CD-42 CD-43 CD-44 CD-69 CD-70 CD-71 CD-73 CD-74 CD-85 CD-90 CD-93 CD-100 CD-124</p>	○ A	SUPPLY	○ B	SIG	○ C	RETURN	8~30V	※ Check contact Normal : 0.1 Ω
○ A	SUPPLY								
○ B	SIG								
○ C	RETURN								
Stop lamp pressure sensor	<table border="1" style="margin-left: auto; margin-right: auto;"> <tr><td>○ A</td><td>SUPPLY</td></tr> <tr><td>○ B</td><td>RETURN</td></tr> <tr><td>○ C</td><td>SIG</td></tr> </table> <p>CD-4</p>	○ A	SUPPLY	○ B	RETURN	○ C	SIG	8~30V	※ Check contact Normal : 0.1 Ω
○ A	SUPPLY								
○ B	RETURN								
○ C	SIG								

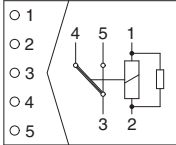
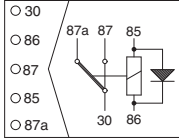
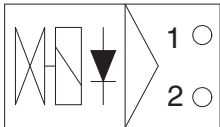
Part name	Symbol	Specifications	Check
Resistor	 <p>CN-173 CN-174</p>	3W	※ Check resistance A-B : 120 Ω
Glow plug	 <p>CN-80</p>	24V 200A	※ Check resistance 0.25~0.12 Ω
Temperature sensor (hydraulic)	 <p>CD-1</p>	-	※ Check resistance 50°C : 804 Ω 80°C : 310 Ω 100°C : 180 Ω
Air cleaner pressure switch	 <p>CD-10</p>	N.O TYPE	※ Check contact High level : ∞ Ω Low level : 0 Ω
Fuel level sender	 <p>CD-2</p>	-	※ Check resistance Full : 50 Ω      6/12 : 350 Ω 11/12 : 100 Ω    5/12 : 400 Ω 10/12 : 150 Ω    4/12 : 450 Ω 9/12 : 200 Ω     3/12 : 500 Ω 8/12 : 250 Ω     2/12 : 550 Ω 7/12 : 300 Ω     1/12 : 600 Ω Empty warning : 700 Ω
Relay (air con blower)		24V 16A	※ Check resistance Normal : About 200 Ω (for terminal 1-3) 0 Ω (for terminal 2-4)

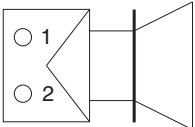
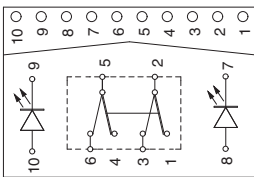
Part name	Symbol	Specifications	Check
Relay	 <p>CR-5 CR-12 CR-15 CR-36 CR-39 CR-45 CR-66 CR-81 CR-82 CR-83 CR-84 CR-85 CR-93 CR-103</p>	24V 16A	※ Check resistance Normal : About 160 Ω (for terminal 1-2) 0 Ω (for terminal 3-4) ∞ Ω (for terminal 3-5)
Relay	 <p>CR-2 CR-4 CR-7 CR-9 CR-13 CR-14 CR-29 CR-30 CR-35 CR-44 CR-46 CR-47 CR-78 CR-79 CR-102 CR-104</p>	24V 16A	※ Check resistance Normal : About 160 Ω (for terminal 85-86) 0 Ω (for terminal 30-87a) ∞ Ω (for terminal 30-87)
Solenoid valve	 <p>CN-66 CN-68 CN-69 CN-70 CN-88 CN-122 CN-123 CN-135 CN-140 CN-149 CN-153 CN-154 CN-181 CN-206 CN-214 CN-216 CN-218 CN-220 CN-237 CN-264 CN-361 CN-362 CN-367 CN-368 CN-369 CN-370 CN-419 CN-420 CN-421</p>	24V 1A	※ Check resistance Normal : 15~25 Ω (for terminal 1-2)
EPPR valve	 <p>CN-75 CN-133 CN-242 CN-246 CN-309 CN-310 CN-365 CN-366 CN-378</p>	700mA	※ Check resistance Normal : 15~25 Ω (for terminal 1-2)
Speaker	 <p>CN-23(LH) CN-23(RH)</p>	20W	※ Check resistance Normal : A few Ω
Switch (locking type)	 <p>CS-52 CS-67 CS-83 CS-99 CS-108 CS-111</p>	24V 1.5A	※ Check contact Normal ON : 0 Ω (for terminal 2-3, 5-6) ∞ Ω (for terminal 1-2, 4-5) OFF : ∞ Ω (for terminal 2-3, 5-6) 0 Ω (for terminal 1-2, 4-5)

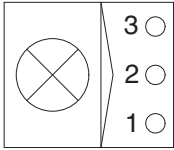
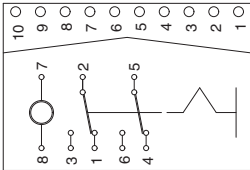
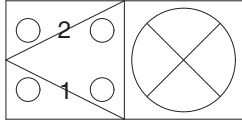
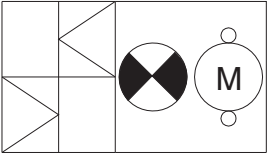
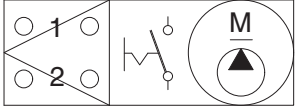
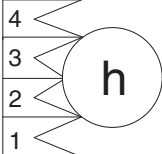
Part name	Symbol	Specifications	Check
Room lamp	 <p>CL-1</p>	24V 10W	※ Check disconnection Normal : 1.0 Ω ON : 0 Ω (For terminal 1-2) ∞ Ω (For terminal 1-3) OFF : ∞ Ω (For terminal 1-2) 0 Ω (For terminal 1-3)
Hazard switch		24V 1.5A	※ Check contact Normal ON : 0 Ω (For terminal 2-3, 5-6) ∞ Ω (For terminal 2-10, 5-4) OFF : ∞ Ω (For terminal 2-3, 5-6) 0 Ω (For terminal 2-10, 5-4)
Work lamp, Cab lamp, Number plate lamp	 <p>CL-5 CL-6 CL-8 CL-9 CL-10 CL-21 CL-24</p>	24V 65W (H3 Type)	※ Check disconnection Normal : 1.2 Ω
Beacon lamp	 <p>CL-7</p>	21V 70W (H1 Type)	※ Check disconnection Normal : A few Ω
Fuel filler pump	 <p>CN-61</p>	24V 10A 35 l /min	※ Check resistance Normal : 1.0 Ω
Hour meter	 <p>CN-48</p>	16~32V	※ Check operation Supply power(24V) to terminal No.2 and connect terminal No.1 and ground

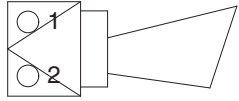
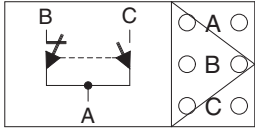
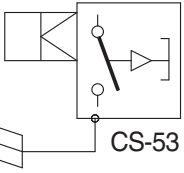
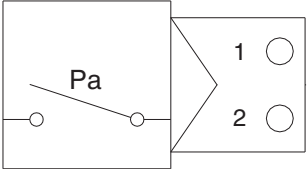
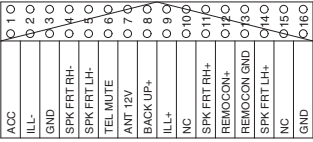
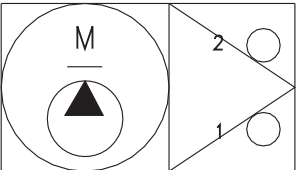

Part name	Symbol	Specifications	Check
Horn	 CN-20 CN-25	DC22~28V 2A	※ Check operation Supply power (24V) to each terminal and connect ground.
Safety switch	 CS-4 CS-20	24V 15A (N.C TYPE)	※ Check contact Normal : 1.0 Ω ON : 0 Ω (for terminal A-B) ∞ Ω (for terminal A-C) OFF : ∞ Ω (for terminal A-B) 0 Ω (for terminal A-C)
Wiper cut switch	 CS-53	24V (N.O TYPE)	※ Check contact Normal : 0 Ω (one pin to ground)
Receiver dryer	 CN-29	24V 2.5A	※ Check contact Normal : ∞ Ω
Radio & USB player	 CN-27A	24V 2A	※ Check voltage 20~25V (for terminal 1-3, 3-8)
Washer pump	 CN-22	24V 3.8A	※ Check contact Normal : 10.7 Ω (for terminal 1-2)

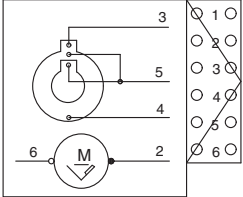
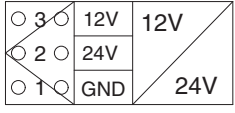
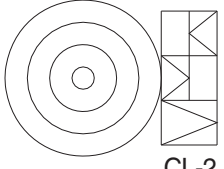
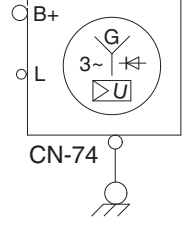
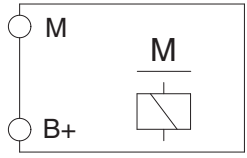
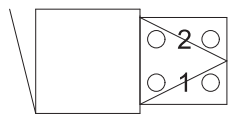
Part name	Symbol	Specifications	Check
Wiper motor	 <p>CN-21</p>	24V 2A	※ Check disconnection Normal : 7 Ω (for terminal 2-6)
DC/DC converter	 <p>CN-138</p>	12V 3A	※ Check voltage 24V (for terminal 1-2) 12V (for terminal 1-3)
Cigar lighter	 <p>CL-2</p>	24V 5A 1.4W	※ Check coil resistance Normal : About 1M Ω ※ Check contact Normal : ∞ Ω Operating time : 5~15sec
Alternator	 <p>CN-74</p>	Denso 24V 95A	※ Check contact Normal : 0 Ω (for terminal B <sup>+</sup> -L) Normal : 24~27.5V
Starter	 <p>CN-45</p>	Nippon denso 24V 4.8kW	※ Check contact Normal : 0.1 Ω
Travel alarm	 <p>CN-81</p>	24V 0.5A	※ Check contact Normal : 5.2 Ω

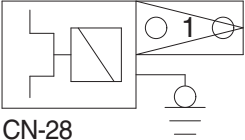
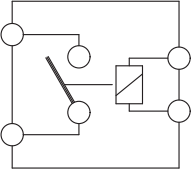
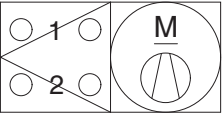
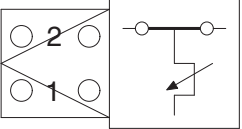
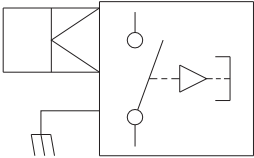
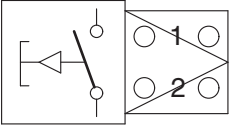
Part name	Symbol	Specifications	Check
Air conditioner compressor	 CN-28	24V 79W	※ Check contact Normal : 13.4 Ω
Start relay	 CR-23	24V 300A	※ Check contact Normal : 0.94 Ω (for terminal 1-2)
Blower motor		24V 9.5A	※ Check resistance Normal : 2.5 Ω (for terminal 1-2)
Duct sensor (switch)		1°C OFF 4°C ON	※ Check resistance Normal : 0 Ω (for terminal 1-2), the atmosphere temp : Over 4°C
Door switch	 CS-1	24V 2W	※ Check resistance Normal : About 5M Ω
Switch (power max, one touch decel, horn, breaker)	 CS-5 CS-19 CS-26 CS-29	24V 6A	※ Check resistance Normal : ∞ Ω

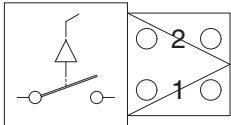
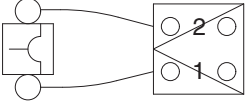
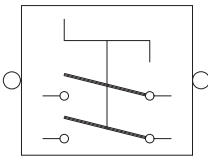
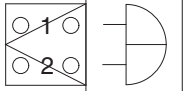
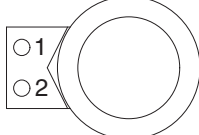
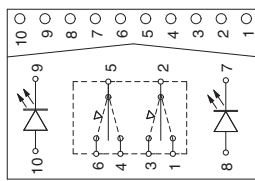
Part name	Symbol	Specifications	Check
Breaker selection switch	 <p>CS-26A</p>	-	-
Circuit breaker	 <p>CN-60 CN-95</p>	CN-60 : 60A CN-95 : 90A	※ Check disconnection Normal : 0 Ω (connect ring terminal and check resist between terminal 1 and 2)
Master switch	 <p>CS-74B</p>	6-36V	※ Check disconnection Normal : 0.1 Ω
Quick clamp buzzer	 <p>CN-113</p>	24V 200mA 107 ± 4dB	-
Socket	 <p>CN-139</p>	12V 10A	-
SCR switch	 <p>CS-100</p>	24V 8A	※ Check contact Normal OFF : ∞ Ω (for terminal 2-1, 2-3, 4-5, 5-6)

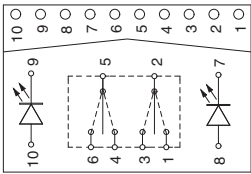
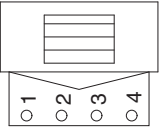
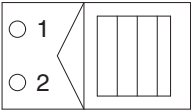
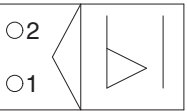
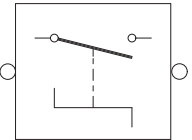
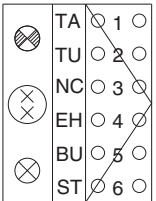
Part name	Symbol	Specifications	Check
Swing lock/fine switch	 <p>CS-73</p>	24V 8A	※ Check contact Normal OFF : $\infty \Omega$ (for terminal 2-1, 2-3, 4-5, 5-6)
Fuel heater	 <p>CN-96</p>	-	-
DEF/AdBlue® line heater	 <p>CN-381 CN-382 CN-383</p>	-	-
WIF sensor	 <p>CD-45</p>	-	※ Check disconnection Normal : 68.8~4.94 $\Omega$
Master switch	 <p>CS-74</p>	6 - 36V	※ Check disconnection Normal : 0.1 $\Omega$
Rear combination lamp-LH,RH	 <p>CL-15 CL-16</p>	24V 21W×2 LED	※ Check resistance Normal : 4.8 $\Omega$ (For terminal 1-4) Normal : 2.1 $\Omega$ (For terminal 2-4, 4-5, 4-6)

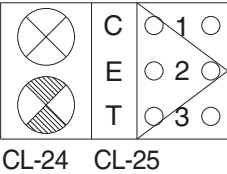
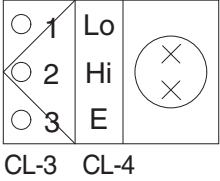
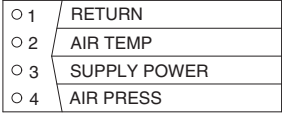
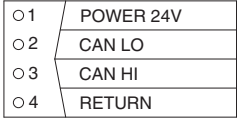
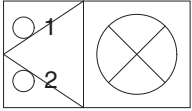
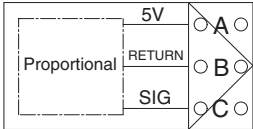
Part name	Symbol	Specifications	Check
Front combination lamp-LH, RH	 <p>CL-24 CL-25</p>	24V 21W 24V 10W	※ Check resistance Normal : 4.8 Ω (For terminal 1-2) Normal : 2.1 Ω (For terminal 2-3)
Head lamp -LH, RH	 <p>CL-3 CL-4</p>	24V 75/70W	※ Check resistance Normal : 1.0 Ω (For terminal 1-3, 2-3) Normal : 1.5 Ω (For terminal 1-2)
PRS temp sensor	 <p>CD-10</p>	5.0V 0.2A	※ Check contact Normal 0 Ω (for terminal 1-2, 47.5 Ω) ∞ Ω (for terminal 3-1, 1k Ω) ∞ Ω (for terminal 4-1, 1k Ω)
Sensor (NOx, SCR, DOC)	 <p>CN-J7A CN-J7B CN-J10 CN-J17</p>	-	-
DEF/AdBlue® fill up warning lamp (LED)	 <p>CL-40</p>	-	-
Proportional valve sensor	 <p>CN-246 CN-247</p>	-	-

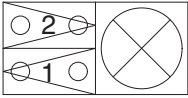
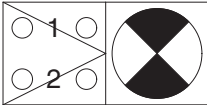
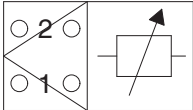
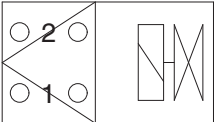
Part name	Symbol	Specifications	Check								
DEF/AdBlue® full lamp	 CL-41	-	-								
Side marker lamp - LH, RH	 CL-26 CL-27	-	-								
Air conditioner temperature sensor (incar, ambient)		-	-								
EPPR valve	 CN-384 CN-J31	24V 700mA	※ Check resistance Normal : 15~25 Ω (For terminal 1-2)								
DEF/AdBlue® tank level sensor	<table border="1" data-bbox="443 1406 715 1541"> <tr><td>○ 1</td><td>POWER</td></tr> <tr><td>○ 2</td><td>RETURN</td></tr> <tr><td>○ 3</td><td>CAN HIGH</td></tr> <tr><td>○ 4</td><td>CAN LOW</td></tr> </table> CN-380	○ 1	POWER	○ 2	RETURN	○ 3	CAN HIGH	○ 4	CAN LOW	-	-
○ 1	POWER										
○ 2	RETURN										
○ 3	CAN HIGH										
○ 4	CAN LOW										
Proportional valve sensor	<table border="1" data-bbox="443 1686 715 1816"> <tr><td>○ 1</td><td>SIG. V(U<sub>s</sub>)</td></tr> <tr><td>○ 2</td><td>SIG. V(U<sub>dc</sub>)</td></tr> <tr><td>○ 3</td><td>GND</td></tr> <tr><td>○ 4</td><td>ERROR</td></tr> </table> CN-307	○ 1	SIG. V(U <sub>s</sub> )	○ 2	SIG. V(U <sub>dc</sub> )	○ 3	GND	○ 4	ERROR	-	-
○ 1	SIG. V(U <sub>s</sub> )										
○ 2	SIG. V(U <sub>dc</sub> )										
○ 3	GND										
○ 4	ERROR										

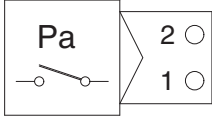
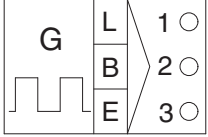
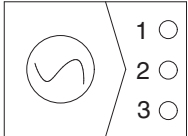
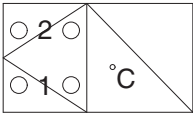
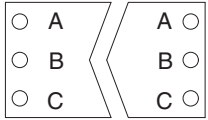
Part name	Symbol	Specifications	Check												
Dozer act pressure switch	 <p>CD-50</p>	N.O type	* Check resistance Normal : ∞ Ω (open)												
Flasher unit	 <p>CR-11</p>	24V 85~190 C/M 50dB	-												
Speed sensor	 <p>CD-46</p>	-	-												
CAC out temperature sensor	 <p>CN-429</p>	-	-												
Smart button	 <p>CS-2B</p>	-	-												
Camera	<table border="1" data-bbox="469 1646 676 1809"> <tr><td>○1</td><td>LVDS POS</td></tr> <tr><td>○2</td><td>GND</td></tr> <tr><td>○3</td><td>LVDS NEG</td></tr> <tr><td>○4</td><td>POWER 24V</td></tr> <tr><td>○5</td><td>NC</td></tr> <tr><td>○6</td><td>ADJUST SIGNAL</td></tr> </table> <p>CN-249 CN-402 CN-403 CN-404 CN-405</p>	○1	LVDS POS	○2	GND	○3	LVDS NEG	○4	POWER 24V	○5	NC	○6	ADJUST SIGNAL	-	-
○1	LVDS POS														
○2	GND														
○3	LVDS NEG														
○4	POWER 24V														
○5	NC														
○6	ADJUST SIGNAL														



## GROUP 4 CONNECTORS

### 1. CONNECTOR DESTINATION

Connector number	Type	No. of pin	Destination	Connector part No.	
				Female	Male
CN-1	AMP	10	I/conn (Frame harness-Pump PS harness)	S816-010002	S816-110002
CN-2	DELPHI	15	I/conn (Frame harness-Engine harness)	13964577	-
CN-3	TYCO	12	I/conn (Frame harness-AAVM harness)	174661-2	368537-1
CN-3A	AMP	12	PVG harness	174661-2	368537-1
CN-4	AMP	16	I/conn (Console harness LH-Frame harness)	368047-1	368050-1
CN-5	DEUTSCH	60	I/conn (Side harness RH-Frame harness)	DRB16-60SAE-L018	DRB12-60PAE-L018
CN-6	AMP	16	I/conn (Console harness RH-Frame harness)	368047-1	368050-1
CN-7	AMP	15	I/conn (Console harness RH-Frame harness)	2-85262-1	936301-1
CN-8	AMP	10	I/conn (Console harness RH-Frame harness)	S816-010002	174655-2
CN-9	DEUTSCH	12	I/conn (Frame harness-AAVM harness)	DT06-12S	DT04-12PA-P021
CN-10	DEUTSCH	12	I/conn (Cab harness-Side harness RH)	DT06-12S-EP06	DT04-12PA-P021
CN-11	DEUTSCH	8	I/conn (Frame harness-Aircon harness)	DT06-8S-EP06	-
CN-11	-	3	Flasher unit	S810-003702	-
CN-12	DEUTSCH	2	I/conn (Frame harness-Boom wire harness)	DT06-2S-EP06	DT04-2P-E004
CN-14	DEUTSCH	2	I/conn (Frame harness-2 way harness)	DT06-2S-EP06	DT04-2P-EP06
CN-15	AMP	8	I/conn (Frame harness-Two way harness)	S816-008002	174984-2
CN-16	AMP	6	Emergency engine start & speed control	S816-006002	-
CN-16A, B	AMP	6	Emergency engine start & speed control	-	S816-106002
CN-17	AMP	8	I/conn (Side harness RH-Wiper motor harness)	S816-008002	S816-108202
CN-20	MOLEX	2	Horn	36825-0211	-
CN-21	AMP	6	Wiper motor	S810-006202	-
CN-22	KET	2	Washer pump	MG640605	-
CN-23	KET	2	Speaker-LH	MG610070	-
CN-24	KET	2	Speaker-RH	MG610070	-
CN-25	MOLEX	2	Horn	36825-0211	-
CN-27A	KUM	16	Radio & USB player	PK145-16017	-
CN-27B	AMP	8	USB player	-	174984-2
CN-28	KUM	1	Aircon compressor	NMWP01F-B	-
CN-29	KET	2	Receiver dryer	MG640795	-
CN-36	TYCO	-	Fuse box (micro relay)	-	3-1393292-8
CN-45	RING-TERM	-	Starter motor B <sup>+</sup>	S820-308000	-
CN-48	KET	1	Service meter	2-520193-2	-
CN-51	DEUTSCH	40	MCU	DRC26-40SA	-
CN-52	DEUTSCH	40	MCU	DRC26-40SC	-

Connector number	Type	No. of pin	Destination	Connector part No.	
				Female	Male
CN-53	DEUTSCH	40	MCU	DRC26-40SA	-
CN-54	DEUTSCH	40	MCU	DRC26-40SA	-
CN-56A	AMP	8	Cluster	-	174663-2
CN-56B	AMP	12	Cluster	-	174984-2
CN-60	AMP	2	Circuit breaker	-	S813-130202
CN-61	DEUTSCH	2	Fuel filler pump	DT06-2S-EP06	-
CN-66	DEUTSCH	2	Breaker solenoid	DT06-2S-EP06	-
CN-68	DEUTSCH	2	Safety solenoid	DT06-2S-EP06	-
CN-69	DEUTSCH	2	Ram lock solenoid	DT06-2S-EP06	-
CN-70	DEUTSCH	2	Travel high solenoid	DT06-2S-EP06	-
CN-74	KET	1	Alternator "L" terminal	MG640-188-4	-
CN-75	AMP	2	Pump EPPR valve	S816-002002	-
CN-80	RING-TERM	-	Glow plug	S820-306000	-
CN-81	DEUTSCH	2	Travel buzzer solenoid	DT06-2S-EP06	-
CN-88	DEUTSCH	2	Power max solenoid	DT06-2S-EP06	-
CN-93	DELPHI	-	To ECU	13964577	-
CN-95	AMP	2	Circuit breaker	-	S813-130202
CN-96	AMP	4	Fuel warmer	2-967325-3	-
CN-97	AMP	12	Multifunction switch	-	S816-112002
CN-98	-	10	Multifunction switch	-	S816-11002
CN-99	-	16	Multifunction switch	-	S816-116002
CN-100	KET	1	Battery earth	MG640994-5	-
CN-113	KET	2	Quick clamp buzzer	MG651205-5	-
CN-122	DEUTSCH	2	Forward solenoid	DT06-2S-EP06	-
CN-123	DEUTSCH	2	Reverse solenoid	DT06-2S-EP06	-
CN-125	Econoseal J	4	GPS connector	S816-004002	S816-104002
CN-125A	DEUTSCH	12	GPS	DT06-12S-P021	DT04-12PA-P021
CN-126	AMP	4	Service tool	2-1418390-1	S816-110002
CN-128	DEUTSCH	2	Rear outrigger solenoid - LH	DT06-2S-EP06	-
CN-131	-	6	I/conn (Frame harness-Stop lamp harness)	S816-006002	S816-106002
CN-133	DEUTSCH	2	Boom priority EPPR valve	DT06-2S-EP06	-
CN-135	DEUTSCH	2	Arm regeneration solenoid	DT06-2S-EP06	-
CN-138	FASTEN	3	DC/DC Converter	S810-003202	-
CN-139	FASTEN	2	12V socket	172434-2	-
CN-140	DEUTSCH	2	Quick clamp solenoid	DT06-2S-EP06	DT04-2P-E005
CN-141	AMP	13	Wiper motor controller	172498-1	DT04-3P-EP10
CN-147	AMP	4	Fuel heater	2-967325-3	-
CN-149	DEUTSCH	2	Attach safety solenoid	DT06-2S-EP06	-

Connector number	Type	No. of pin	Destination	Connector part No.	
				Female	Male
CN-153	DEUTSCH	2	Travel safety solenoid	DT06-2S-EP06	-
CN-154	DEUTSCH	2	Travel safety solenoid	DT06-2S-EP06	-
CN-155	DEUTSCH	8	Slipling (Frame harness-Lower harness)	DT06-8S-EP06	DT04-8P-E003
CN-156	DEUTSCH	60	TMCU	DRC26-40SA	-
CN-156	DEUTSCH	2	Air seat	-	DT04-2P
CN-157	AMP	1	Antena power	S822-014002	-
CN-173	DEUTSCH	3	Resistor	DT06-3S-EP06	DT04-3P-EP10
CN-174	DEUTSCH	3	Resistor	DT06-3S-EP06	-
CN-181	DEUTSCH	2	Travel low speed solenoid	DT06-2S-EP06	-
CN-206	DEUTSCH	2	Creep solenoid	DT06-2S-EP06	-
CN-214	DEUTSCH	2	Front outrigger solenoid - RH	DT06-2S-EP06	-
CN-216	DEUTSCH	2	Front outrigger solenoid - LH	DT06-2S-EP06	-
CN-220	DEUTSCH	2	Rear outrigger solenoid - RH	DT06-2S-EP06	-
CN-237	DEUTSCH	2	Attach confluc solenoid	DT06-2S-EP06	-
CN-242	DEUTSCH	2	Attachment EPPR 1 pressure sensor	DT06-2S-EP06	-
CN-245	-	2	PTC Power	S813-030201	-
CN-246	DEUTSCH	2	Cruise solenoid	DT06-2S-EP06	-
CN-249	DEUTSCH	6	Rear view camera	DT06-6S-EP06	DT04-6P
CN-258	KET	1	Air compressor	MG640944-5	-
CN-263	DEUTSCH	2	Air compressor	DT06-2S-EP06	-
CN-264	DEUTSCH	2	2 PCS solenoid	DT06-2S-EP06	DT04-2P-E005
CN-305	DEUTSCH	12	AAVM	DTM06-12SA	-
CN-306	DEUTSCH	12	AAVM	DTM06-12SB	-
CN-307	DEUTSCH	3	Service tool	DT06-3S-EP06	DT06-3P-E005
CN-308	-	4	PVG32	2-967059-1	-
CN-309	DEUTSCH	2	A1 EPPR valve	DT06-2S-EP06	-
CN-310	DEUTSCH	2	A2 EPPR valve	DT06-2S-EP06	-
CN-363	-	12	Haptic controller	174045-2	-
CN-365	DEUTSCH	2	Attachment relief EPPR valve 1	DT06-2S-EP06	-
CN-366	DEUTSCH	2	Attachment relief EPPR valve 2	DT06-2S-EP06	DT04-2P-E005
CN-367	DEUTSCH	2	Boom down floating solenoid	DT06-2S-EP06	-
CN-368	DEUTSCH	2	Boom up floating solenoid	DT06-2S-EP06	-
CN-369	DEUTSCH	2	Boom down cut-off solenoid	DT06-2S-E005	-
CN-370	DEUTSCH	2	Swing fine control solenoid	DT06-2S-EP06	DT04-2P-E005
CN-376	TYCO	23	RDU	7706087-2	-
CN-378	DEUTSCH	2	Attachment EPPR 2 pressure sensor	DT06-2S-EP06	-
CN-379	TYCO	12	SCR supply module	2-1703639-1	-
CN-381	BOSCH	2	DEF/AdBlue® line heater 1	1-928-403-847	-

Connector number	Type	No. of pin	Destination	Connector part No.	
				Female	Male
CN-382	BOSCH	2	DEF/AdBlue® line heater 2	1-928-403-847	-
CN-383	BOSCH	2	DEF/AdBlue® line heater 3	1-928-403-847	-
CN-384	DEUTSCH	2	Coolant valve	DT06-2S-EP06	-
CN-385	-	7	Fan clutch	965570	-
CN-398	DEUTSCH	4	RS 232	DT04-4S-E005	DT06-4P-E005
CN-399	TYCO	-	DEF/AdBlue® tank level sensor	1-967325-1	-
CN-399	DEUTSCH	4	Service tool	-	DT04-4P-E005
CN-401	FCI	90	AAVM controller	A2C00021583	-
CN-402	DEUTSCH	6	Front view camera	DT06-6S-P021	DT04-6P-P021
CN-403	DEUTSCH	6	Rear view camera	-	DT04-6P-EP14
CN-404	DEUTSCH	6	Left view camera	-	DT04-6P-EP14
CN-405	DEUTSCH	6	Right view camera	-	DT04-6P-EP14
CN-406	DEUTSCH	3	RS 232	DT06-3S-EP06	DT04-3P-E005
CN-419	DEUTSCH	2	Swing parking A1	DT06-2S-EP06	-
CN-420	DEUTSCH	2	Swing parking A2	DT06-2S-EP06	-
CN-421	DEUTSCH	2	Swing parking A3	DT06-2S-EP06	-
CN-427	MOLEX	4	Reader	039012040	026013096
		12		5557-12R	5559-12P
CN-429	DELPHI	2	CAC out temperature	12162197	-
CN-430	DEUTSCH	6	l/conn (Side harness RH-Aftertreatment harness)	DT06-6S-EP06	DT06-6P-E005
CN-J7A	TYCO	4	DOC NOx sensor	2-1418390-1	-
CN-J7B	TYCO	4	SCR NOx sensor	1-1418390-1	-
CN-J10	TYCO	4	SCR thermistor	5-1418390-1	-
CN-J17	TYCO	4	DOC thermistor	4-1418390-1	-
CN-J31	BOSCH	2	DEF/AdBlue® dosing module	1_928_403_874	-
· Relay					
CR-1	RING-TERM	-	Battery relay	ST710289-2	-
CR-2	-	5	Horn relay	-	-
CR-4	-	5	Working lamp relay	-	-
CR-5	-	5	Anti restart relay	-	-
CR-7	-	5	Aircon compressor relay	-	-
CR-9	-	5	Cabin lamp relay	-	-
CR-11	AMP	3	Flasher unit relay	S810-003702	-
CR-12	-	5	Travel speed relay	-	-
CR-13	-	5	Head lamp low relay	-	-
CR-14	-	5	Head lamp high relay	-	-
CR-15	-	5	Illumination relay	-	-
CR-23	KET	2	Start relay	S814-002001	-
CR-24	RING TERM	1	Preheat relay	S822-014000	-

Connector number	Type	No. of pin	Destination	Connector part No.	
				Female	Male
CR-29	-	5	Travel forward relay	-	-
CR-30	-	5	Travel reverse relay	-	-
CR-35	-	5	Power relay	-	-
CR-36	-	5	Preheat relay	-	-
CR-39	-	5	Starter lockout relay	-	-
CR-44	-	5	Rear work lamp relay	-	-
CR-45	-	5	Stop lamp relay	-	-
CR-46	-	5	Fuel warmer relay	-	-
CR-47	-	5	Safety solenoid relay	-	-
CR-62	-	5	Breaker relay	-	-
CR-66	-	5	Parking relay	-	-
CR-78	-	5	Head lamp power relay	-	-
CR-79	-	5	Pedal relay	-	-
CR-81	-	5	Front outrigger relay - RH	-	-
CR-82	-	5	Front outrigger relay - LH	-	-
CR-83	-	5	Rear outrigger relay - RH	-	-
CR-84	-	5	Rear outrigger relay - LH	-	-
CR-85	-	5	Beacon lamp relay	-	-
CR-93	-	5	Travel buzzer lamp relay	-	-
CR-102	-	5	NOx sensor relay	-	-
CR-103	-	5	DEF module relay	-	-
CR-104	-	5	Line heater relay	-	-
· Switch					
CS-1	SHUR	1	Door switch	S822-014002	-
CS-2A	WP	6	Start key switch	S814-006100	-
CS-2B	DEUTSCH	3	Smart key	DT06-3S-EP06	DT04-3P-E005
CS-4	DEUTSCH	3	Safety switch 1	DT06-3S-EP06	-
CS-5	DEUTSCH	2	Horn switch	-	DT04-2P-E005
CS-19	DEUTSCH	2	One touch decel switch	-	DT04-2P-E005
CS-20	AMP	1	Safety switch 2	S822-014002	-
CS-26	DEUTSCH	2	Breaker switch	DT06-2S-EP06	-
CS-29	DEUTSCH	2	Power max switch	DT06-2S-EP06	-
CS-52	CARLING	10	Travel buzzer	VC2-01	-
CS-52	CARLING	10	2 PCS & dozer switch	VC2-01	-
CS-53	AMP	1	Wiper cut switch	S822-014002	-
CS-67	CARLING	10	Quick clamp switch	VC2-01	-
CS-73	CARLING	10	Swing lock & fine switch	VC2-01	-
CS-74A	AMP	2	Master switch	S813-030201	-

Connector number	Type	No. of pin	Destination	Connector part No.	
				Female	Male
CS-74B	DEUTSCH	2	Master switch	DT06-2S-EP06	-
CS-78	CARLING	10	Lower wiper switch	VC2-01	-
CS-99	CARLING	10	Air compressor switch	VC2-01	-
CS-100	CARLING	10	SCR switch	VC2-01	-
CS-108	CARLING	10	Auto grease switch	VC2-01	-
CS-111	CARLING	10	Boom floating switch	VC2-01	-
· Light					
CL-1	KET	3	Room lamp	MG651032	-
CL-2	AMP	1	Cigar lighter	S822-014002	S822-114002
CL-3	-	3	Head lamp-LH	S810-003702	-
CL-4	-	3	Head lamp-RH	S810-003702	-
CL-5	DEUTSCH	2	Work lamp-LH	DT06-2S-EP06	-
CL-6	DEUTSCH	2	Work lamp-RH	DT06-2S-EP06	-
CL-7	SHUR	1	Beacon lamp	S822-014002	S822-114002
CL-8	DEUTSCH	2	Cab light-LH	DT06-2S-EP06	DT04-2P
CL-9	DEUTSCH	2	Cab light-RH	DT06-2S-EP06	DT04-2P
CL-10	DEUTSCH	2	Cab light-RH	DT06-2S-EP06	DT04-2P
CL-15	AMP	6	Rear combination lamp-LH	PB625-06027	-
CL-16	AMP	6	Rear combination lamp-RH	PB625-06027	-
CL-21	KET	2	Number plate lamp	-	S814-102000
CL-24	AMP	3	Front combination lamp-LH	S816-003002	-
CL-24	DEUTSCH	2	Rear work lamp	DT06-2S-EP06	DT04-2P-E005
CL-25	AMP	3	Front combination lamp-RH	S816-003002	-
CL-26	-	2	Side marker-LH	S816-002002	-
CL-27	-	3	Side marker-RH	S816-002002	-
CL-40	DEUTSCH	2	DEF/AdBlue® lamp	DT06-2S-EP06	-
CL-41	DEUTSCH	2	DEF/AdBlue® Fill up warning lamp	DT06-2S-EP06	-
· Sensor, sendor					
CD-1	AMP	2	Hydraulic oil temp sender	85202-1	-
CD-2	DEUTSCH	2	Fuel level sender	DT06-2S-EP06	-
CD-3	DEUTSCH	3	Brake oil pressure sensor	DT06-3S-EP06	-
CD-4	DEUTSCH	3	Stop lamp pressure sensor	DT06-3S-EP06	-
CD-5	DEUTSCH	3	Transmission oil pressure sensor	DT06-3S-EP06	-
CD-6	DEUTSCH	3	Travel pressure sensor	DT06-3S-EP06	-
CD-7	DEUTSCH	3	Working pressure sensor	DT06-3S-EP06	-
CD-9	DEUTSCH	3	Arm in pressure sensor	DT06-3S-EP06	-
CD-10	SUMITOMO	4	PRS temperature sensor	6098-0144	-
CD-10	AMP	2	Air cleaner switch	85202-1	-

Connector number	Type	No. of pin	Destination	Connector part No.	
				Female	Male
CD-16	AMP	3	Water level sensor	1211-0293	-
CD-24	DEUTSCH	3	Swing pressure sensor	DT06-3S-EP06	-
CD-31	DEUTSCH	3	Overload pressure sensor	DT06-3S-EP06	-
CD-32	DEUTSCH	3	Boom up pressure sensor	DT06-3S-EP06	-
CD-35	DEUTSCH	3	Arm in & out and bucket in pressure sensor	DT06-3S-EP06	-
CD-38	DEUTSCH	3	Work brake pressure sensor	DT06-3S-EP06	-
CD-42	DEUTSCH	3	Pump pressure 1	DT06-3S-EP06	-
CD-43	DEUTSCH	3	Pump pressure 2	DT06-3S-EP06	-
CD-44	DEUTSCH	3	Pump pressure 3	DT06-3S-EP06	-
CD-45	DEUTSCH	2	WIF sensor	DT06-2S-EP06	-
CD-46	AMP	3	Speed sensor	282087	-
CD-50	KET	2	Outrigger action pressure sensor	MG640975	-
CD-66	DEUTSCH	2	Breaker pressure sensor	DT06-2S-EP06	-
CD-69	DEUTSCH	3	Attach pressure sensor	DT06-3S-EP06	-
CD-70	DEUTSCH	3	N1 pressure sensor	DT06-3S-EP06	-
CD-71	DEUTSCH	3	N2 pressure sensor	DT06-3S-EP06	-
CD-73	DEUTSCH	3	Travel forward pressure sensor	DT06-3S-EP06	-
CD-74	DEUTSCH	3	Travel reverse pressure sensor	DT06-3S-EP06	DT04-3P
CD-85	DEUTSCH	3	Boom down pressure sensor	DT06-3S-EP06	-
CD-90	DEUTSCH	3	Arm in pressure soensor	DT06-3S-EP06	-
CD-100	DEUTSCH	3	Outrigger pressure sensor	DT06-3S-EP06	-
CD-124	DEUTSCH	3	Boom rod cylinder pressure sensor	DT06-3S-EP06	-

## 2. CONNECTION TABLE FOR CONNECTORS

### 1) PA TYPE CONNECTOR

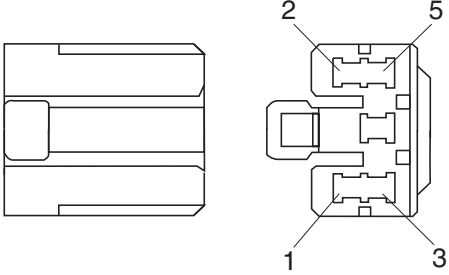
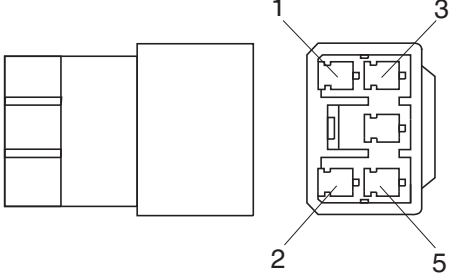
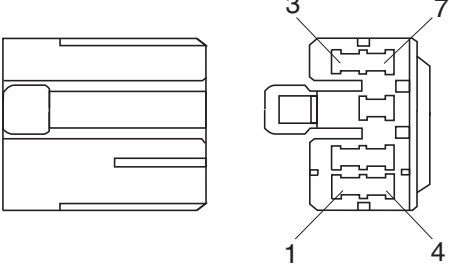
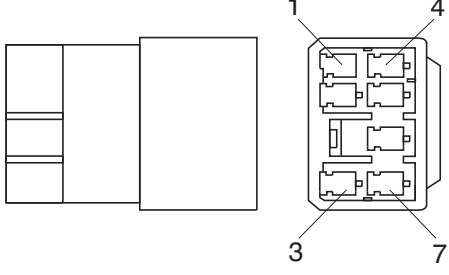
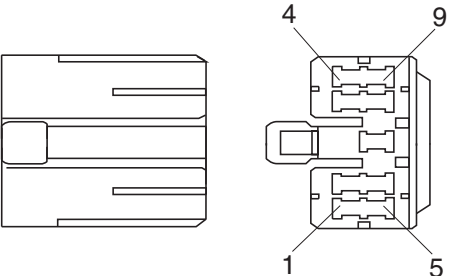
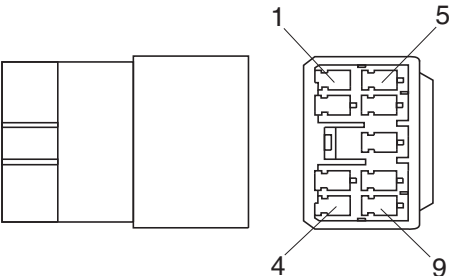
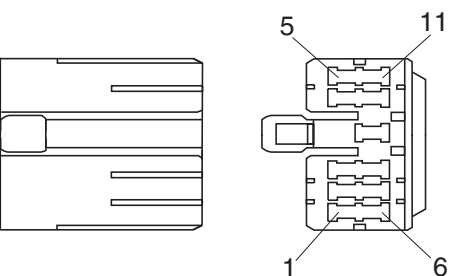
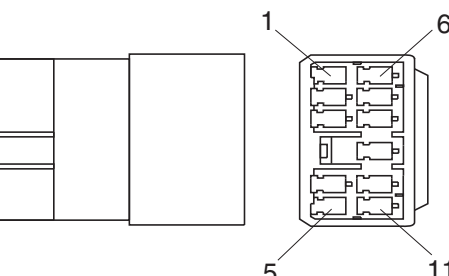
No. of pin	Receptacle connector (female)	Plug connector (male)
5	 <p data-bbox="687 734 836 768">S811-005002</p>	 <p data-bbox="1241 734 1390 768">S811-105002</p>
7	 <p data-bbox="687 1144 836 1178">S811-007002</p>	 <p data-bbox="1241 1144 1390 1178">S811-107002</p>
9	 <p data-bbox="687 1550 836 1583">S811-009002</p>	 <p data-bbox="1230 1550 1378 1583">3S811-109002</p>
11	 <p data-bbox="687 1957 836 1991">S811-011002</p>	 <p data-bbox="1241 1957 1390 1991">S811-111002</p>

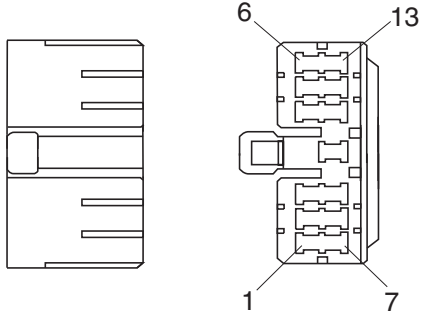
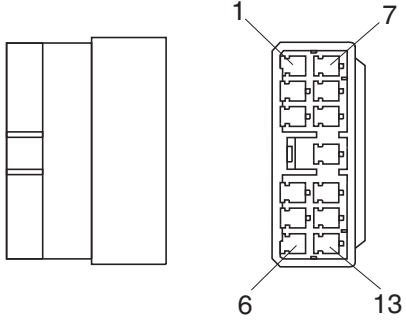
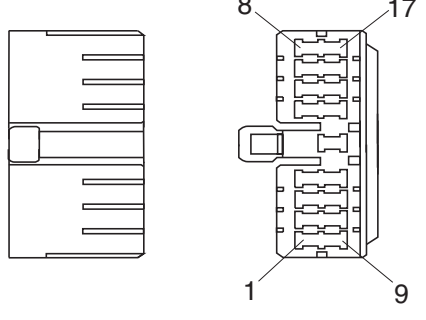
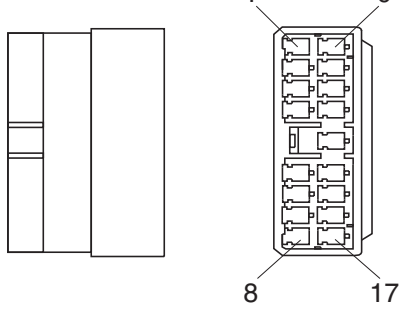
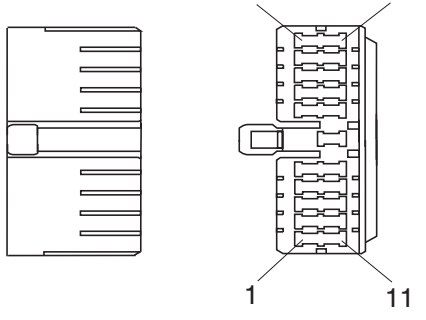
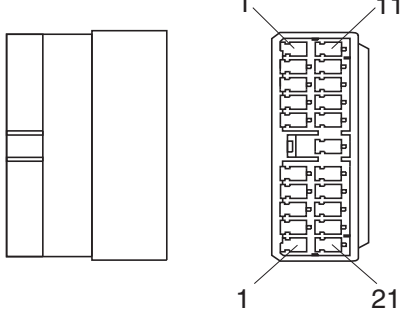

No. of pin	Receptacle connector (female)	Plug connector (male)
13	 <p style="text-align: center;">S811-013002</p>	 <p style="text-align: center;">S811-113002</p>
17	 <p style="text-align: center;">S811-017002</p>	 <p style="text-align: center;">S811-117002</p>
21	 <p style="text-align: center;">S811-021002</p>	 <p style="text-align: center;">S811-121002</p>

## 2) J TYPE CONNECTOR

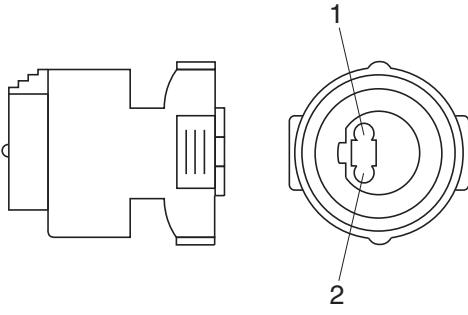
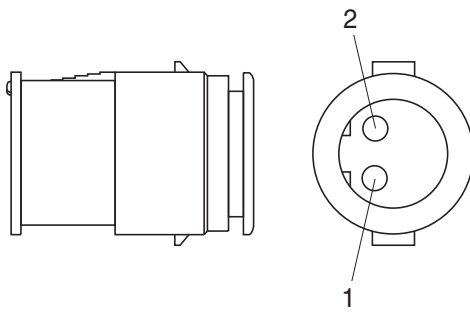
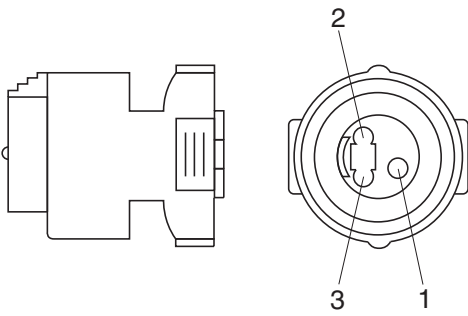
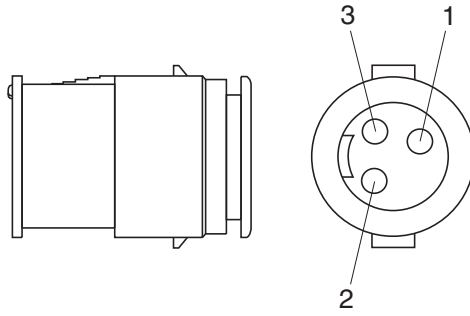
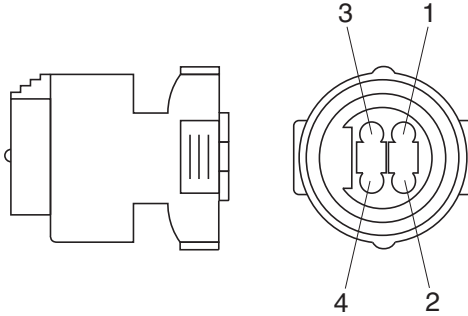
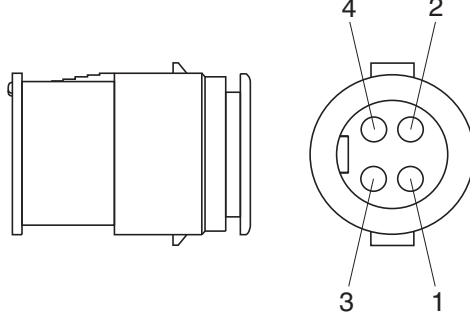
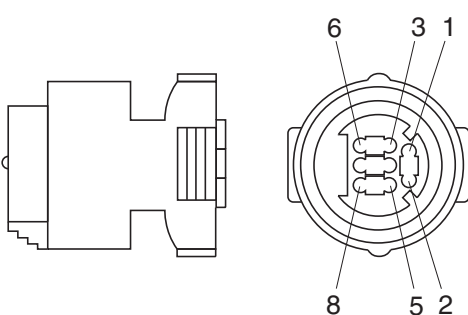
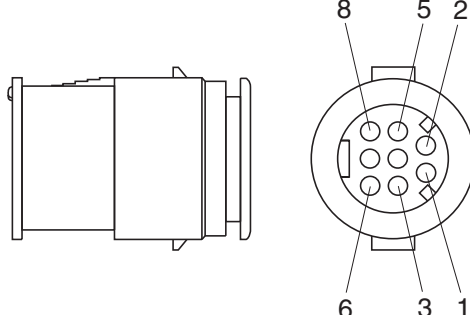
No. of pin	Receptacle connector (female)	Plug connector (male)
2	 <p style="text-align: center;">S816-002001</p>	 <p style="text-align: center;">S816-102001</p>
3	 <p style="text-align: center;">S816-003001</p>	 <p style="text-align: center;">S816-103001</p>
4	 <p style="text-align: center;">S816-004001</p>	 <p style="text-align: center;">S816-104001</p>
8	 <p style="text-align: center;">S816-008001</p>	 <p style="text-align: center;">S816-108001</p>

### 3) SWP TYPE CONNECTOR

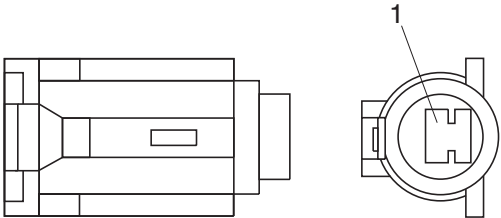
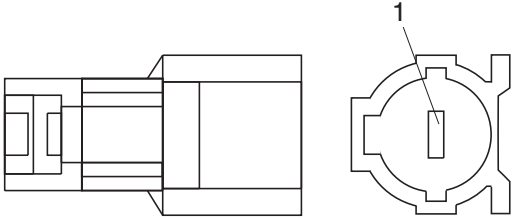
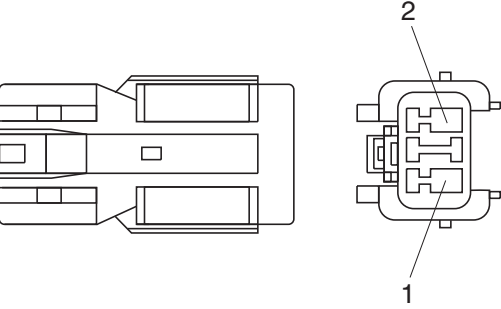
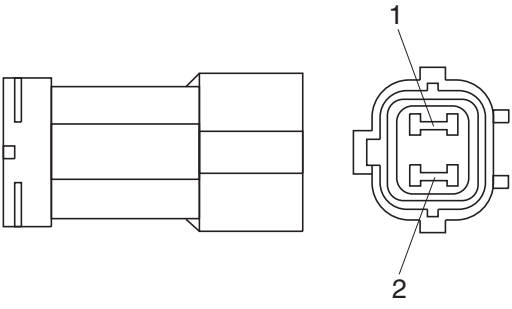
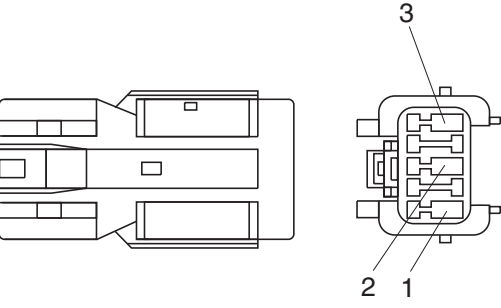
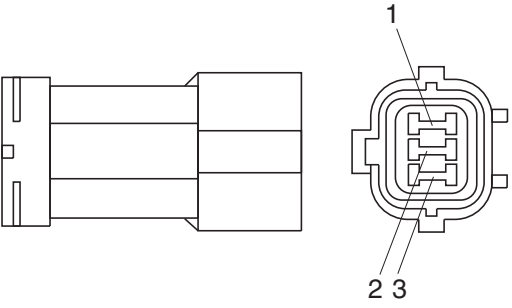
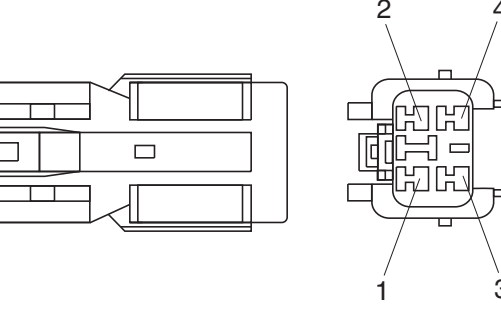
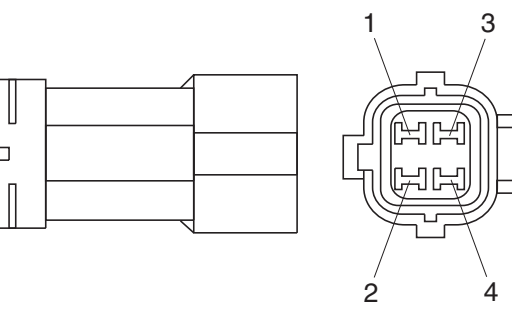
No. of pin	Receptacle connector (female)	Plug connector (male)
1	 <p data-bbox="687 685 836 712">S814-001000</p>	 <p data-bbox="1241 685 1390 712">S814-101000</p>
2	 <p data-bbox="687 1093 836 1120">S814-002000</p>	 <p data-bbox="1241 1093 1390 1120">S814-102000</p>
3	 <p data-bbox="687 1500 836 1527">S814-003000</p>	 <p data-bbox="1241 1500 1390 1527">S814-103000</p>
4	 <p data-bbox="687 1904 836 1930">S814-004000</p>	 <p data-bbox="1241 1904 1390 1930">S814-104000</p>

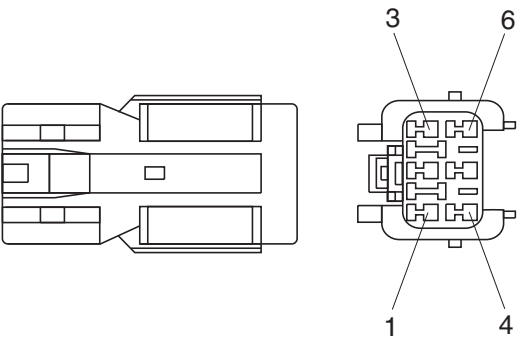
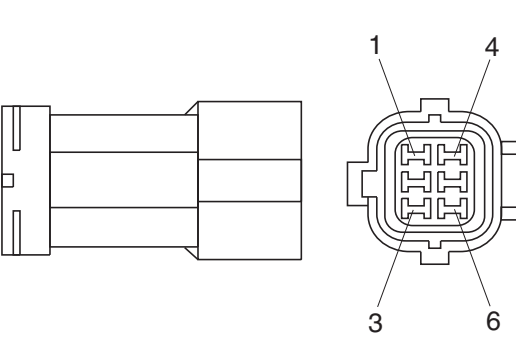
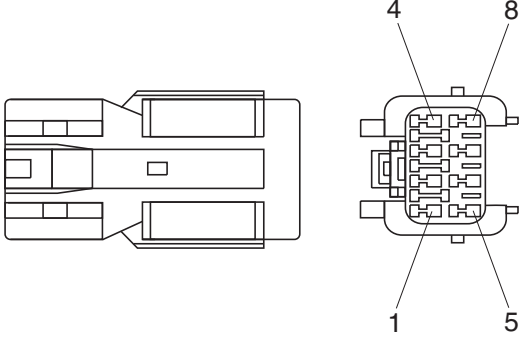
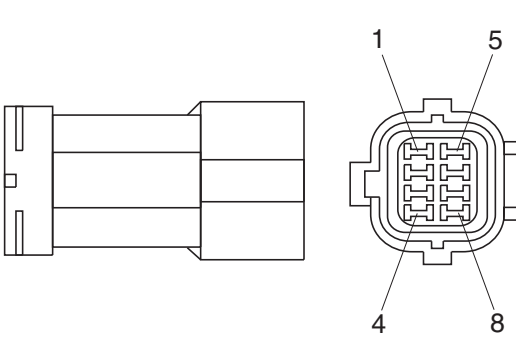
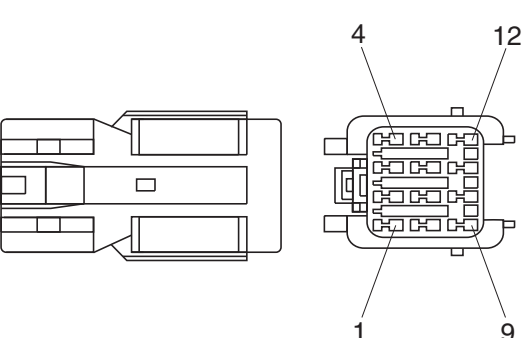
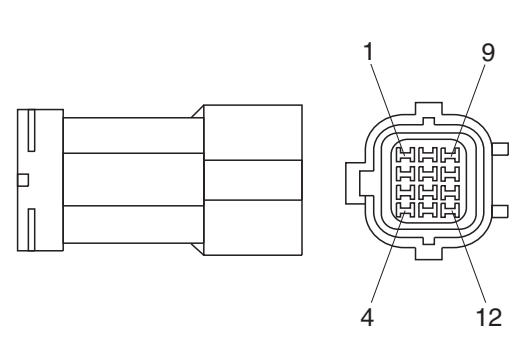
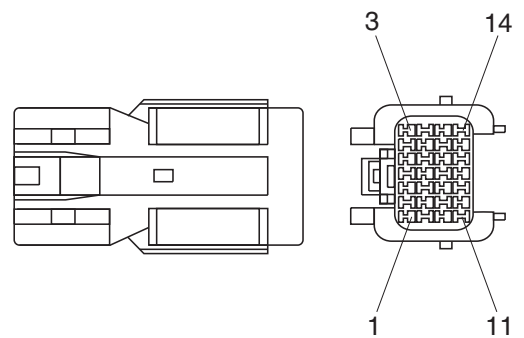
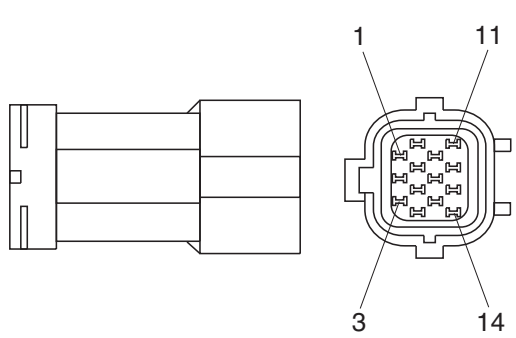
No. of pin	Receptacle connector (female)	Plug connector (male)
6	 <p data-bbox="686 638 837 672">S814-006000</p>	 <p data-bbox="1244 638 1396 672">S814-106000</p>
8	 <p data-bbox="686 1041 837 1075">S814-008000</p>	 <p data-bbox="1244 1041 1396 1075">S814-108000</p>
12	 <p data-bbox="686 1444 837 1478">S814-012000</p>	 <p data-bbox="1244 1444 1396 1478">S814-112000</p>
14	 <p data-bbox="686 1848 837 1881">S814-014000</p>	 <p data-bbox="1244 1848 1396 1881">S814-114000</p>

#### 4) CN TYPE CONNECTOR

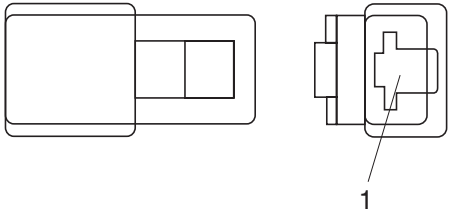
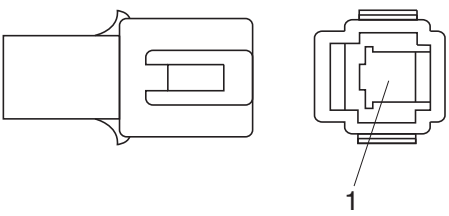
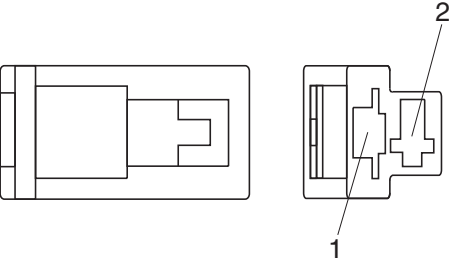
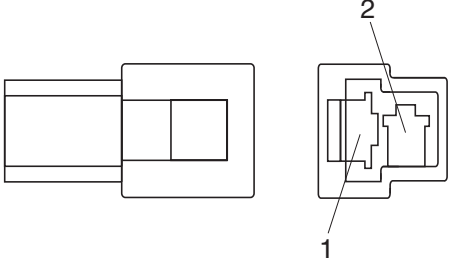
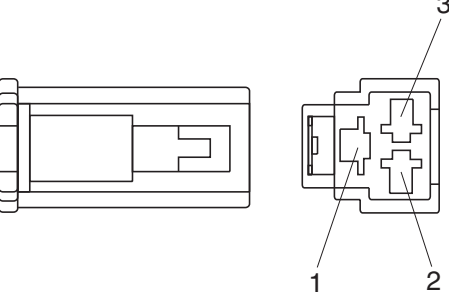
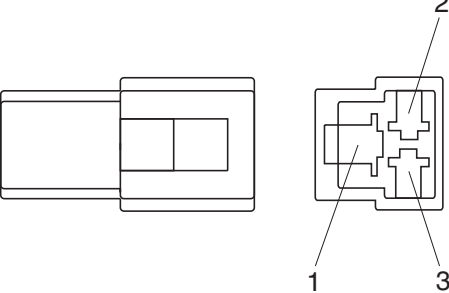
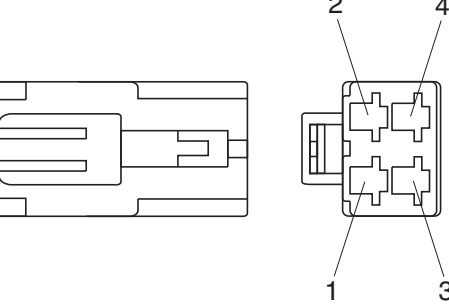
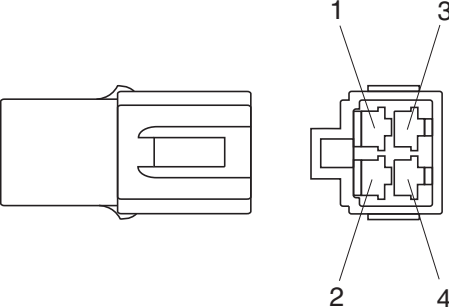
No. of pin	Receptacle connector (female)	Plug connector (male)
1	 <p style="text-align: center;">S810-001202</p>	 <p style="text-align: center;">S810-101202</p>
2	 <p style="text-align: center;">S810-002202</p>	 <p style="text-align: center;">S810-102202</p>
3	 <p style="text-align: center;">S810-003202</p>	 <p style="text-align: center;">S810-103202</p>
4	 <p style="text-align: center;">S810-004202</p>	 <p style="text-align: center;">S810-104202</p>

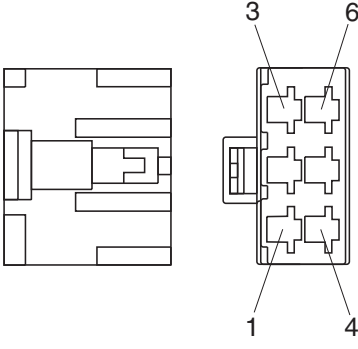
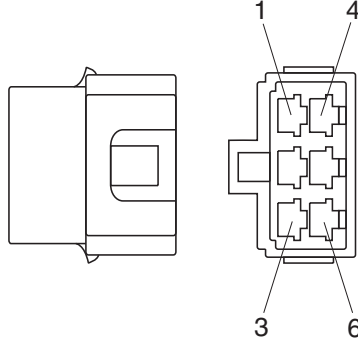
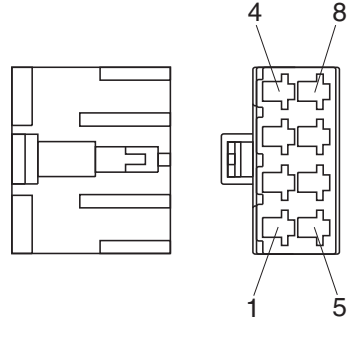
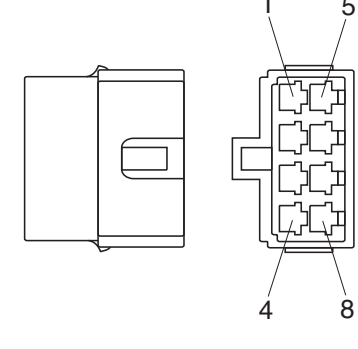
No. of pin	Receptacle connector (female)	Plug connector (male)
6	 <p data-bbox="686 645 837 678">S810-006202</p>	 <p data-bbox="1244 645 1396 678">S810-106202</p>
8	 <p data-bbox="686 1059 837 1093">S810-008202</p>	 <p data-bbox="1244 1059 1396 1093">S810-108202</p>

### 5) 375 FASTEN TYPE CONNECTOR

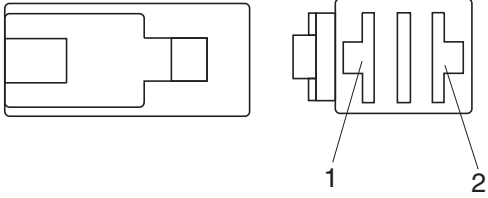
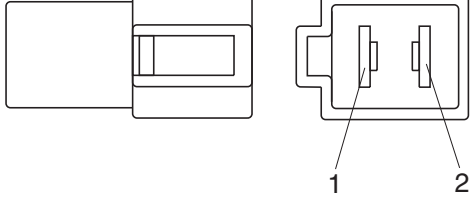
No. of pin	Receptacle connector (female)	Plug connector (male)
2	 <p style="text-align: center;">S810-002402</p>	 <p style="text-align: center;">S810-102402</p>

### 6) AMP ECONOSEAL CONNECTOR

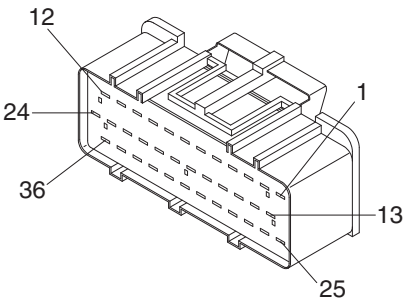
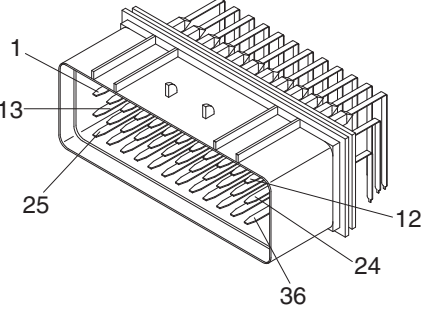
No. of pin	Receptacle connector (female)	Plug connector (male)
36	 <p style="text-align: center;">344111-1</p>	 <p style="text-align: center;">344108-1</p>

### 7) AMP TIMER CONNECTOR

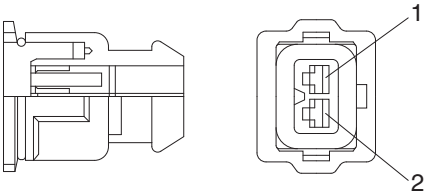
No. of pin	Receptacle connector (female)	Plug connector (male)
2	 <p style="text-align: center;">85202-1</p>	

### 8) AMP 040 MULTILOCK CONNECTOR

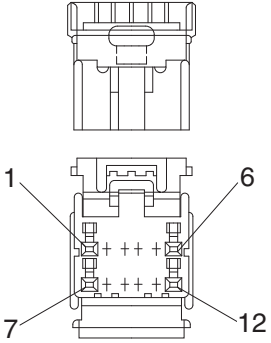
No. of pin	Receptacle connector (female)	Plug connector (male)
12	 <p style="text-align: right;">174045-2</p>	

### 9) AMP 070 MULTILOCK CONNECTOR

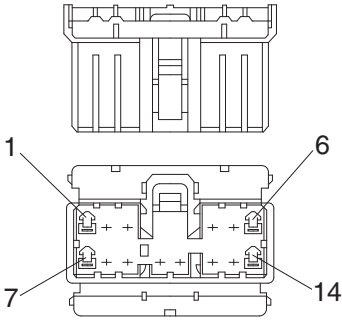
No. of pin	Receptacle connector (female)	Plug connector (male)
14	 <p style="text-align: right;">173852</p>	

### 10) AMP FASTIN - FASTON CONNECTOR

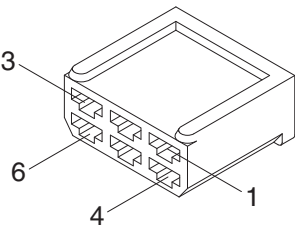
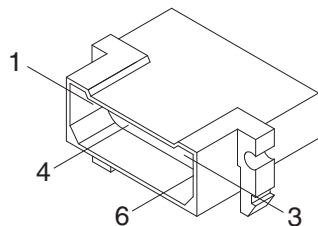
No. of pin	Receptacle connector (female)	Plug connector (male)
6	 <p style="text-align: right;">925276-0</p>	 <p style="text-align: right;">480003-9</p>

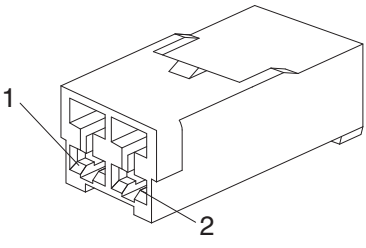

### 11) KET 090 CONNECTOR

No. of pin	Receptacle connector (female)	Plug connector (male)
2	 <p style="text-align: right;">MG610070</p>	

### 12) KET 090 WP CONNECTORS

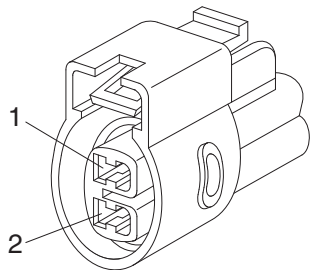
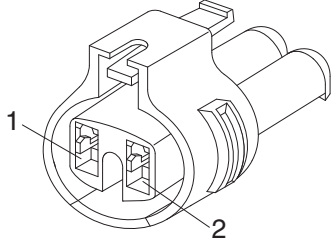
No. of pin	Receptacle connector (female)	Plug connector (male)
2	 <p style="text-align: right;">MG640605</p>	
2	 <p style="text-align: right;">MG640795</p>	

### 13) KET SDL CONNECTOR

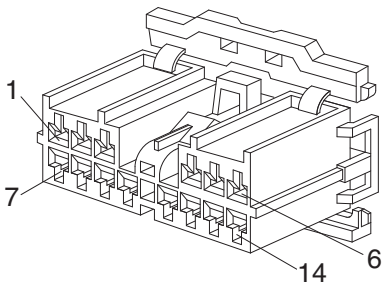
No. of pin	Receptacle connector (female)	Plug connector (male)
14	 <p data-bbox="710 683 837 705">MG610406</p>	

## 14) DEUTSCH DT CONNECTORS

DT 06 - 3S - ★★★★★

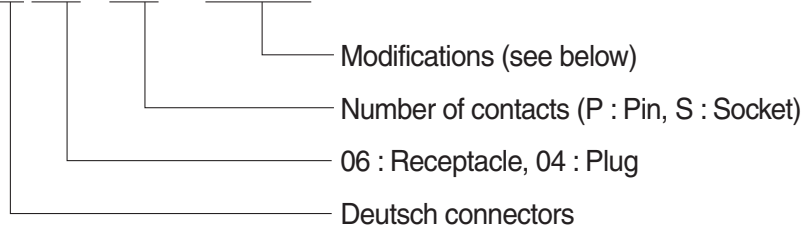

※ Modification

E003 : Standard end cap - gray

E004 : Color of connector to be black

E005 : Combination - E004 & E003

EP04 : End cap

EP06 : Combination P012 & EP04

P012 : Front seal enhancement - connectors color to black for 2, 3, 4 & 6pin

No. of pin	Receptacle connector (female)	Plug connector (male)
2	<p>DT06-2S</p>	<p>DT04-2P</p>
3	<p>DT06-3S</p>	<p>DT04-3P</p>
4	<p>DT06-4S</p>	<p>DT04-4P</p>

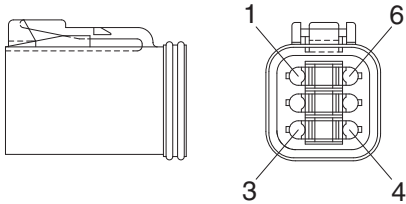
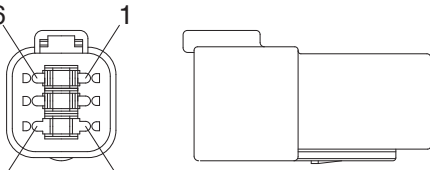
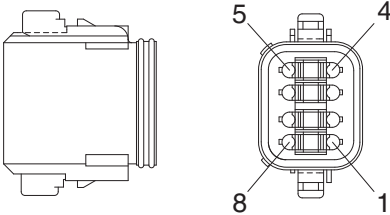
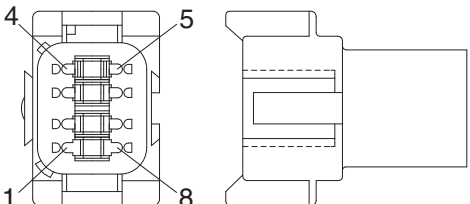
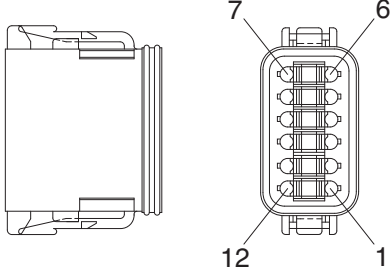
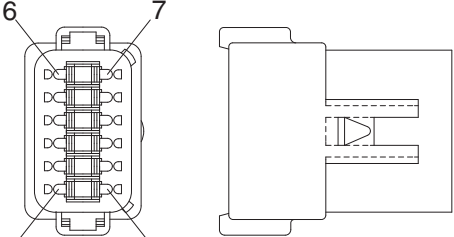
No. of pin	Receptacle connector (female)	Plug connector (male)
6	 <p style="text-align: center;">DT06-6S</p>	 <p style="text-align: center;">DT04-6P</p>
8	 <p style="text-align: center;">DT06-8S</p>	 <p style="text-align: center;">DT04-8P</p>
12	 <p style="text-align: center;">DT06-12S</p>	 <p style="text-align: center;">DT04-12P</p>

**15) MOLEX 2CKTS CONNECTOR**

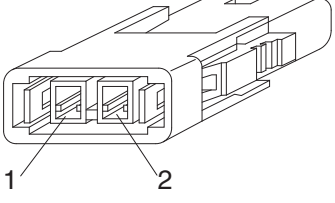
No. of pin	Receptacle connector (female)	Plug connector (male)
2	 <p style="text-align: right;">35215-0200</p>	

**16) ITT SWF CONNECTOR**

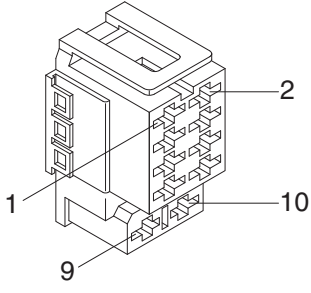
No. of pin	Receptacle connector (female)	Plug connector (male)
10	 <p style="text-align: right;">SWF593757</p>	

**17) MWP NMWP CONNECTOR**

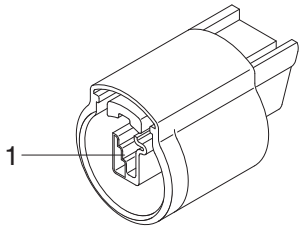
No. of pin	Receptacle connector (female)	Plug connector (male)
1	 <p style="text-align: right;">NMWP01F-B</p>	

### 18) ECONOSEAL J TYPE CONNECTORS

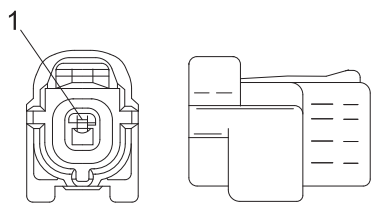
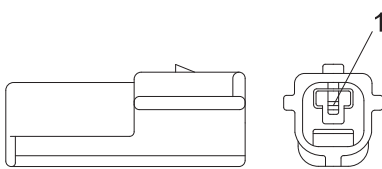
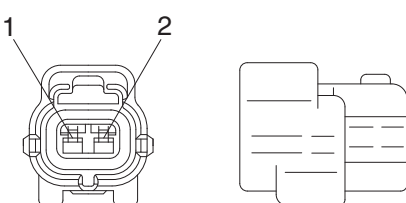
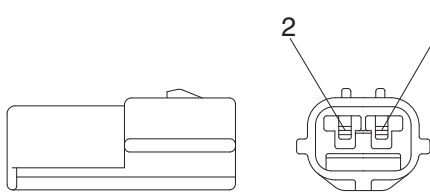
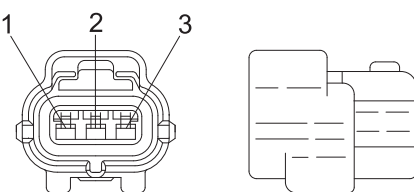
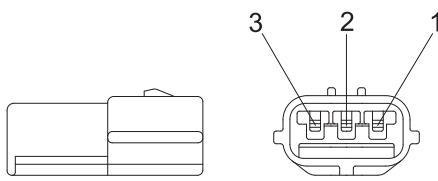
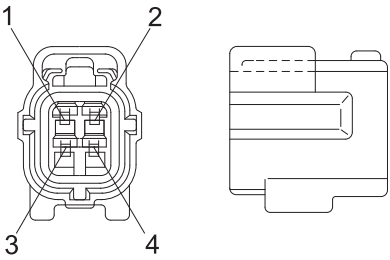
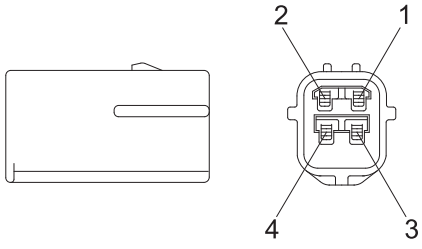
No. of pin	Receptacle connector (female)	Plug connector (male)
1	 <p style="text-align: center;">S816-001002</p>	 <p style="text-align: center;">S816-101002</p>
2	 <p style="text-align: center;">S816-002002</p>	 <p style="text-align: center;">S816-102002</p>
3	 <p style="text-align: center;">S816-003002</p>	 <p style="text-align: center;">S816-103002</p>
4	 <p style="text-align: center;">S816-004002</p>	 <p style="text-align: center;">S816-104002</p>

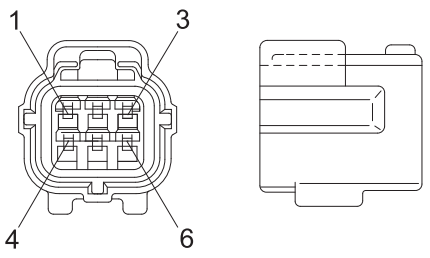
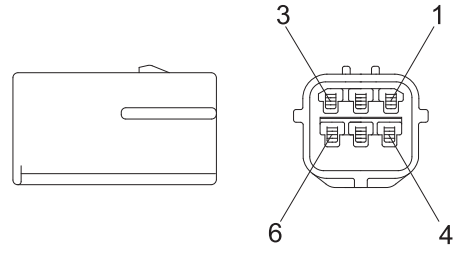
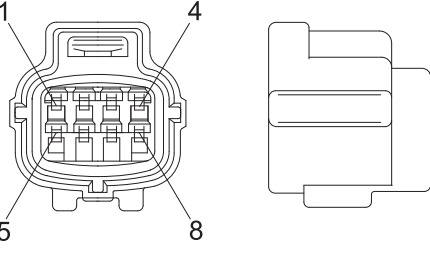
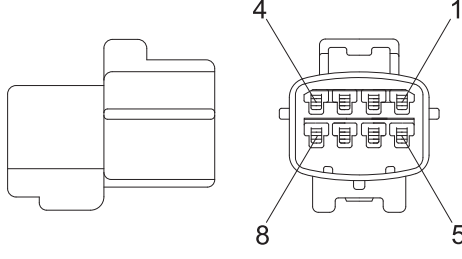
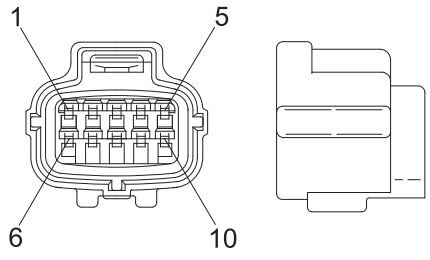
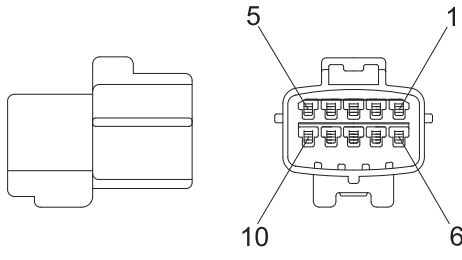
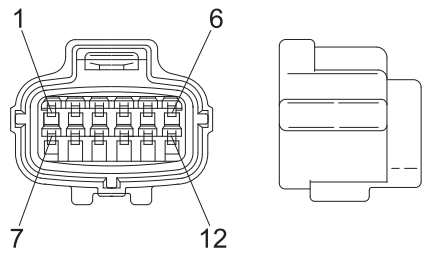
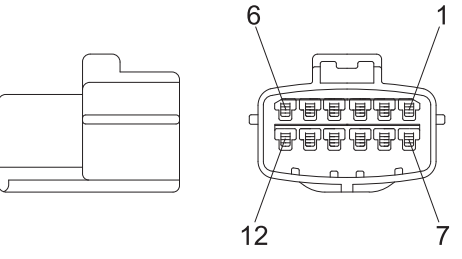
No. of pin	Receptacle connector (female)	Plug connector (male)
6	 <p data-bbox="686 638 837 672">S816-006002</p>	 <p data-bbox="1236 638 1388 672">S816-106002</p>
8	 <p data-bbox="686 1041 837 1075">S816-008002</p>	 <p data-bbox="1236 1041 1388 1075">S816-108002</p>
10	 <p data-bbox="686 1444 837 1478">S816-010002</p>	 <p data-bbox="1236 1444 1388 1478">S816-110002</p>
12	 <p data-bbox="686 1848 837 1881">S816-012002</p>	 <p data-bbox="1236 1848 1388 1881">S816-112002</p>

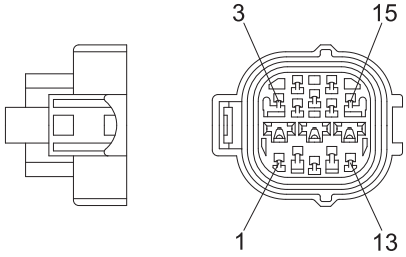
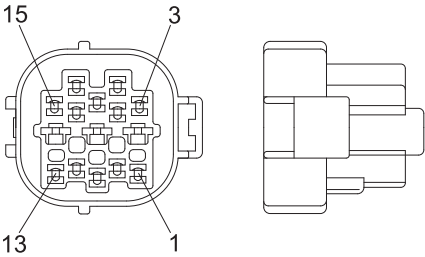
No. of pin	Receptacle connector (female)	Plug connector (male)
15	 <p data-bbox="730 636 836 667">368301-1</p>	 <p data-bbox="1278 636 1383 667">2-85262-1</p>

### 19) METRI-PACK TYPE CONNECTOR

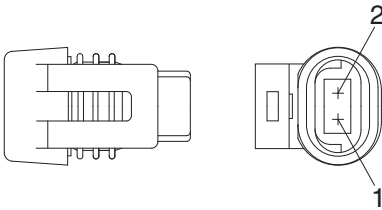
No. of pin	Receptacle connector (female)	Plug connector (male)
2	 <p data-bbox="724 1238 829 1270">12040753</p>	

### 20) DEUTSCH HD30 CONNECTOR

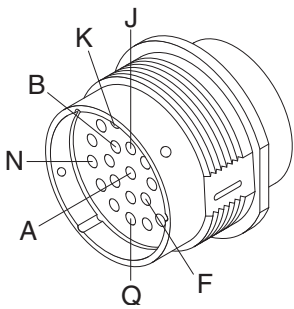
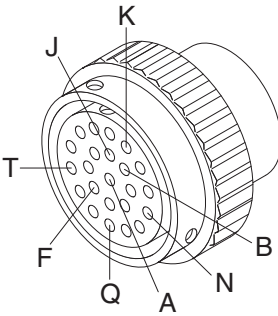
No. of pin	Receptacle connector (female)	Plug connector (male)
23	 <p data-bbox="667 1839 836 1870">HD36-24-23SN</p>	 <p data-bbox="1219 1839 1388 1870">HD34-24-23PN</p>

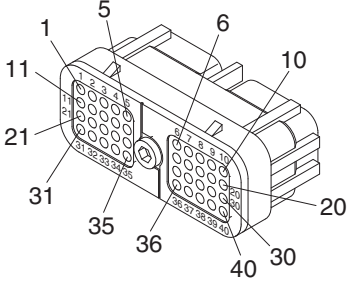

### 21) DEUTSCH MCU CONNECTOR

No. of pin	Receptacle connector (female)	Plug connector (male)
40	 <p style="text-align: right;">DRC26-40SA/B</p>	

### 22) DEUTSCH SERVICE TOOL CONNECTOR

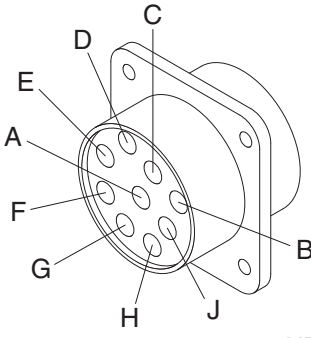
No. of pin	Receptacle connector (female)	Plug connector (male)
9	 <p style="text-align: right;">HD10-9-96P</p>	

### 23) AMP FUEL WARMER CONNECTOR

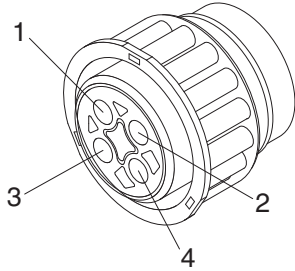
No. of pin	Receptacle connector (female)	Plug connector (male)
4	 <p style="text-align: right;">2-967325-3</p>	

### 24) DEUTSCH ENGINE ECM CONNECTOR

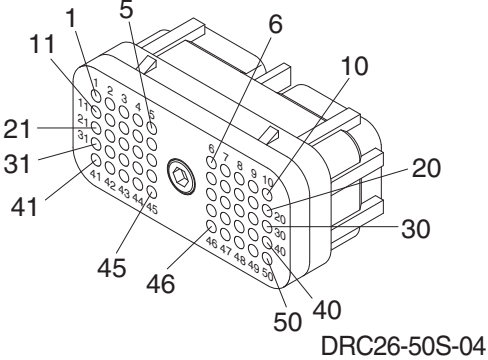
No. of pin	Receptacle connector (female)	Plug connector (male)
50	 <p style="text-align: right;">DRC26-50S-04</p>	

### 25) DEUTSCH INTERMEDIATE CONNECTOR

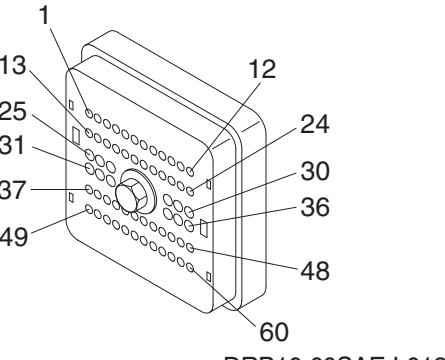
No. of pin	Receptacle connector (female)	Plug connector (male)
60	 <p style="text-align: right;">DRB16-60SAE-L018</p>	