

SECTION 6 TROUBLESHOOTING

Group 1 Before Troubleshooting	6-1
Group 2 Hydraulic and Mechanical System	6-4
Group 3 Electrical System	6-26
Group 4 Mechatronics System	6-42
Group 5 Air conditioner and Heater System	6-73

SECTION 6 TROUBLESHOOTING

GROUP 1 BEFORE TROUBLESHOOTING

1. INTRODUCTION

When a trouble is occurred in the machine, this section will help an service man to repair the machine with easy.

The trouble of machine is parted Hydraulic & Mechanical system, Electrical system and Mechatronics system. At each system part, an service man can check the machine according to the troubleshooting process diagram.

※ **Before carrying out troubleshooting procedure, check monitoring menu in the cluster.**

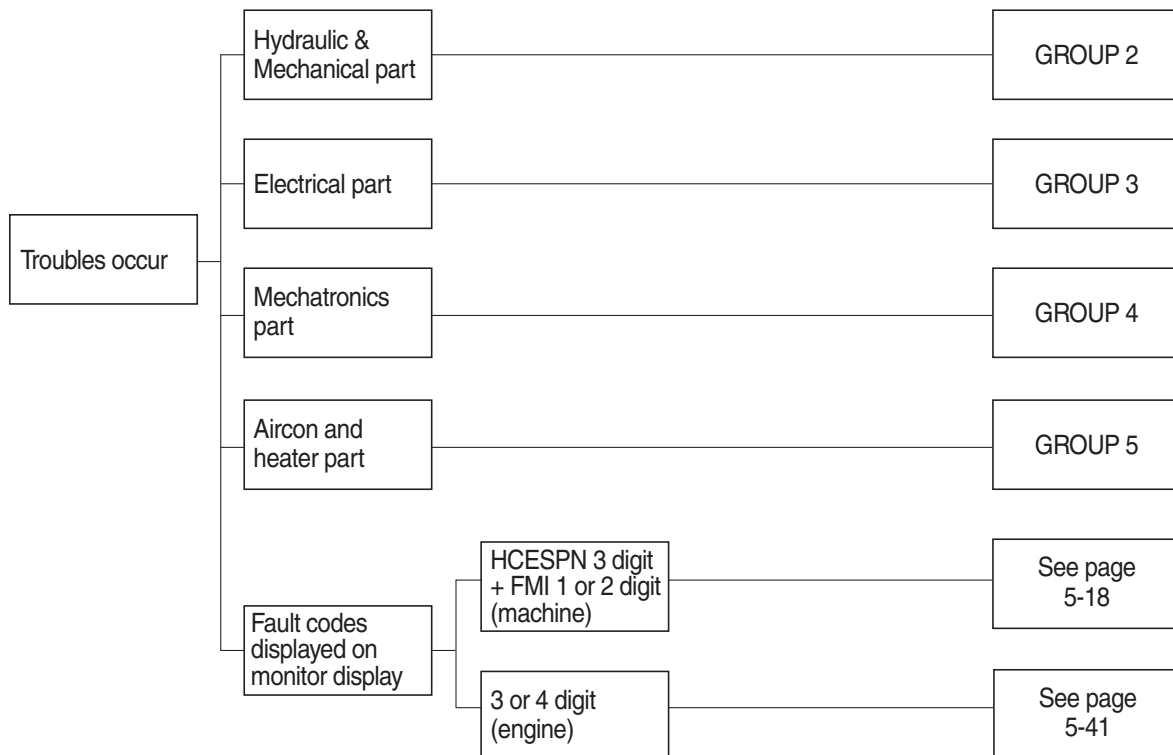

2. DIAGNOSING PROCEDURE

To carry out troubleshooting efficiently, the following steps must be observed.

STEP 1. Study the machine system

Study and know how the machine is operating, how the system is composing, what kinds of function are installed in the machine and what are specifications of the system components by the machine service manual.

Especially, deepen the knowledge for the related parts of the trouble.

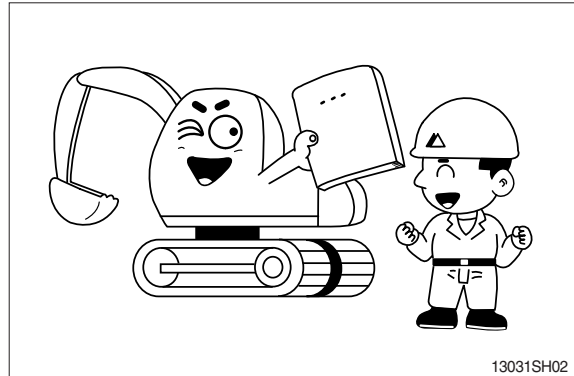

STEP 2. Ask the operator

Before inspecting, get the full story of malfunctions from a witness --- the operator.

- 1) How the machine is used and when it is serviced?
- 2) When the trouble was noticed and what work the machine was doing at that time?
- 3) What is the phenomenon of the trouble?
Was the trouble getting worse, or did it come out suddenly for the first time?
- 4) Did the machine have any troubles previously? If so, which parts were repaired before.

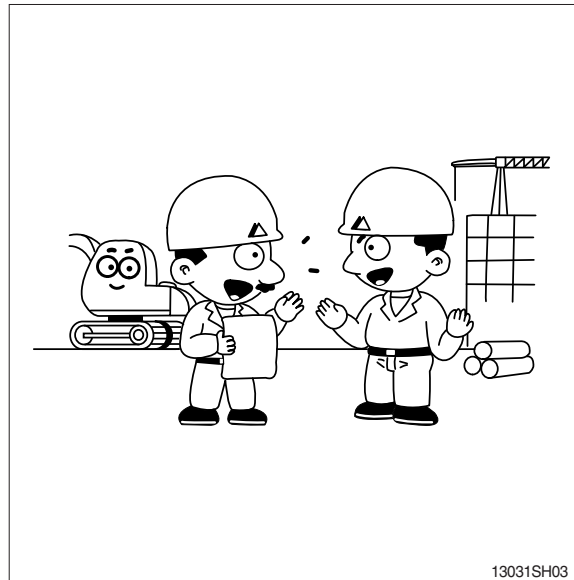

STEP 3. Inspect the machine

Before starting troubleshooting, check the machine for the daily maintenance points as shown in the operator's manual.

And also check the electrical system including batteries, as the troubles in the electrical system such as low battery voltage, loose connections and blown out fuses will result in malfunction of the controllers causing total operational failures of the machine.

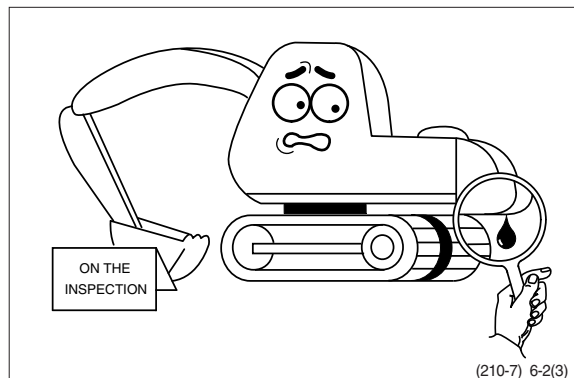

STEP 4. Inspect the trouble actually on the machine

In case that some trouble cannot be confirmed, obtain the details of the malfunction from the operator.

Also, check if there are any incomplete connections of the wire harnesses or not.

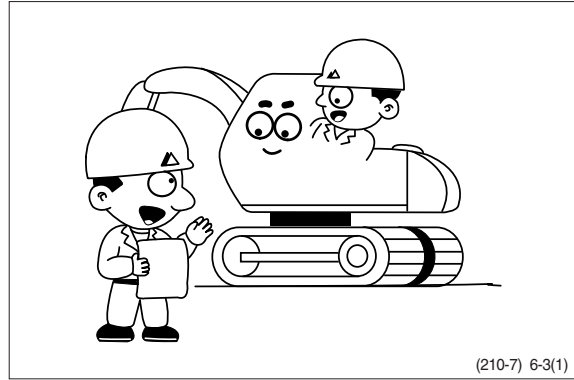

STEP 5. Perform troubleshooting

According to where the trouble parts are located, hydraulic & mechanical system part or electrical system part or mechatronics system part, perform troubleshooting the machine refer to the each system part's troubleshooting process diagram.

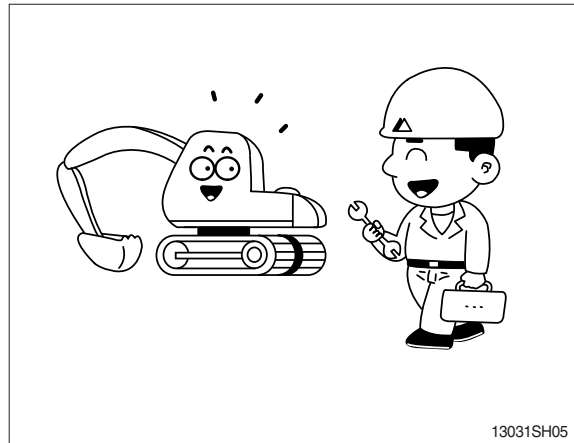

STEP 6. Trace a cause

Before reaching a conclusion, check the most susceptible causes again. Try to trace what the real cause of the trouble is.

Make a plan of the appropriate repairing procedure to avoid consequential malfunctions.

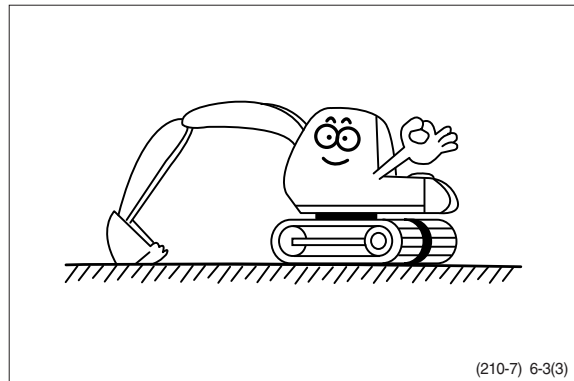

GROUP 2 HYDRAULIC AND MECHANICAL SYSTEM

1. INTRODUCTION

1) MACHINE IN GENERAL

- (1) If even a minor fault is left intact and operation is continued, a fatal failure may be caused, entailing a large sum of expenses and long hours of restoration.
Therefore when even a small trouble occurs, do not rely on your intuition and experience, but look for the cause based on the troubleshooting principle and perform maintenance and adjustment to prevent major failure from occurring. Keep in mind that a fault results from a combination of different causes.
- (2) The following lists up commonly occurring faults and possible causes with this machine. For the troubleshooting of the engine, refer to the coming troubleshooting and repair.
- (3) When carrying out troubleshooting, do not hurry to disassemble the components.
It will become impossible to find the cause of the problem.
- (4) Ask user or operator the following.
 - ① Was there any strange thing about machine before failure occurred?
 - ② Under what conditions did the failure occur?
 - ③ Have any repairs been carried out before the failure?
- (5) Check before troubleshooting.
 - ① Check oil and fuel level.
 - ② Check for any external leakage of oil from components.
 - ③ Check for loose or damage of wiring and connections.

2) MACHINE STATUS MONITORING ON THE CLUSTER

- (1) The machine status such as the engine rpm, oil temperature, voltage and pressure etc. can be checked by this menu.

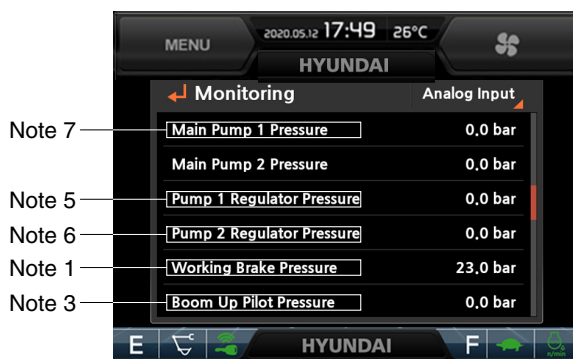

Analog 1

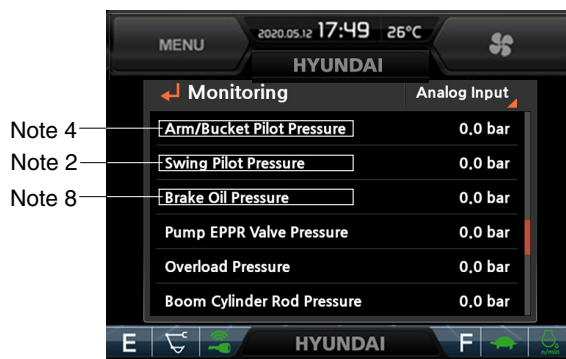

Analog 2

140WA6HS01

(2) Specification

No.	Description	Specification
Note 1	Work pilot pressure	$40 \begin{smallmatrix} +2 \\ 0 \end{smallmatrix}$ bar
Note 2	Swing pilot pressure	0~40 bar
Note 3	Boom up pilot pressure	0~40 bar
Note 4	Arm/bucket pilot pressure	0~40 bar
Note 5	Pump 1 regulator pressure	0~50 bar
Note 6	Pump 2 regulator pressure	0~50 bar
Note 7	Pump 1 pressure	350 bar
Note 8	Brake oil pressure	60 ± 3 bar

2. DRIVE SYSTEM

1) UNUSUAL NOISE COMES OUT OF PUMP CONNECTION

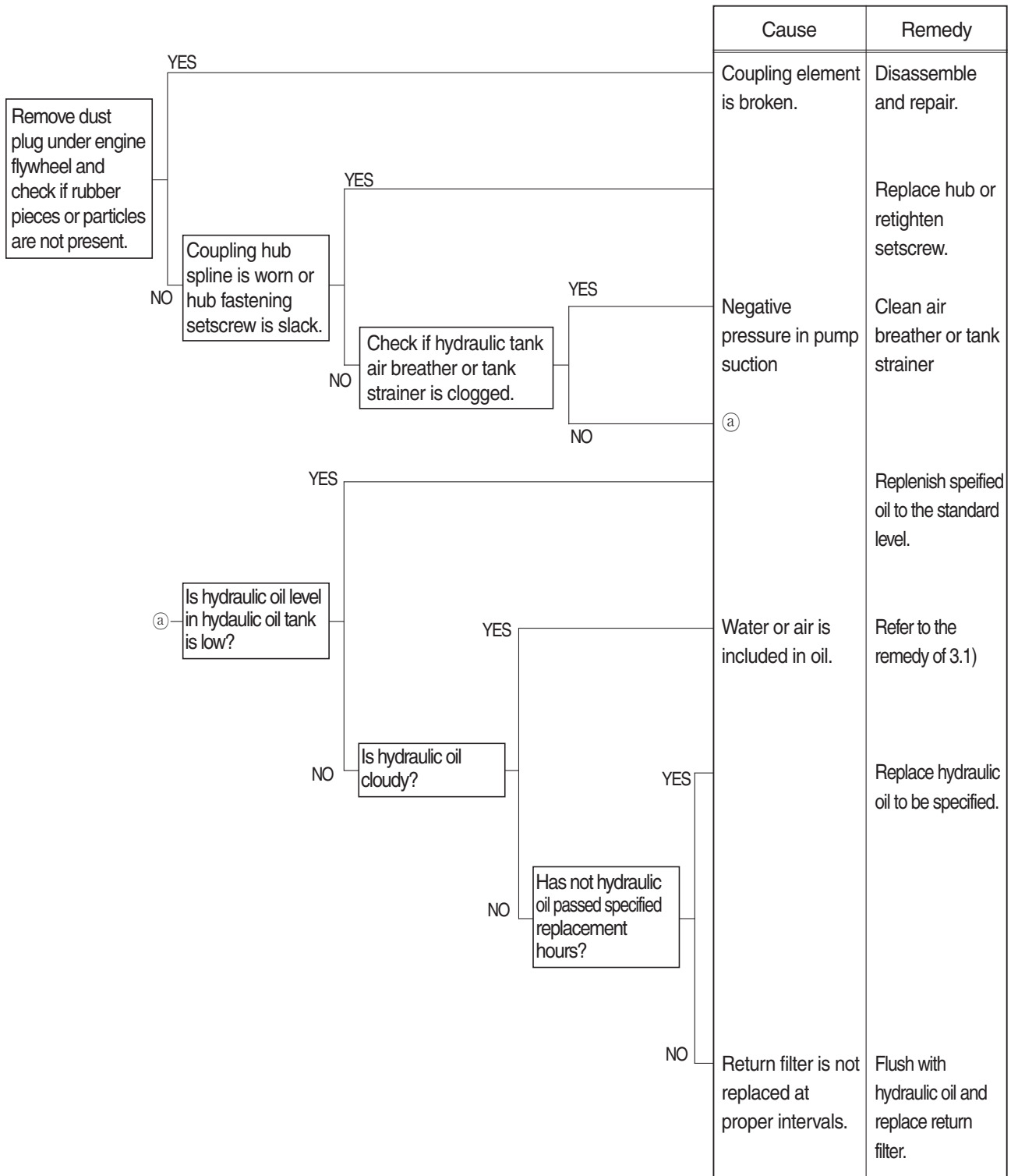

2) ENGINE STARTS BUT MACHINE DOES NOT OPERATE AT ALL

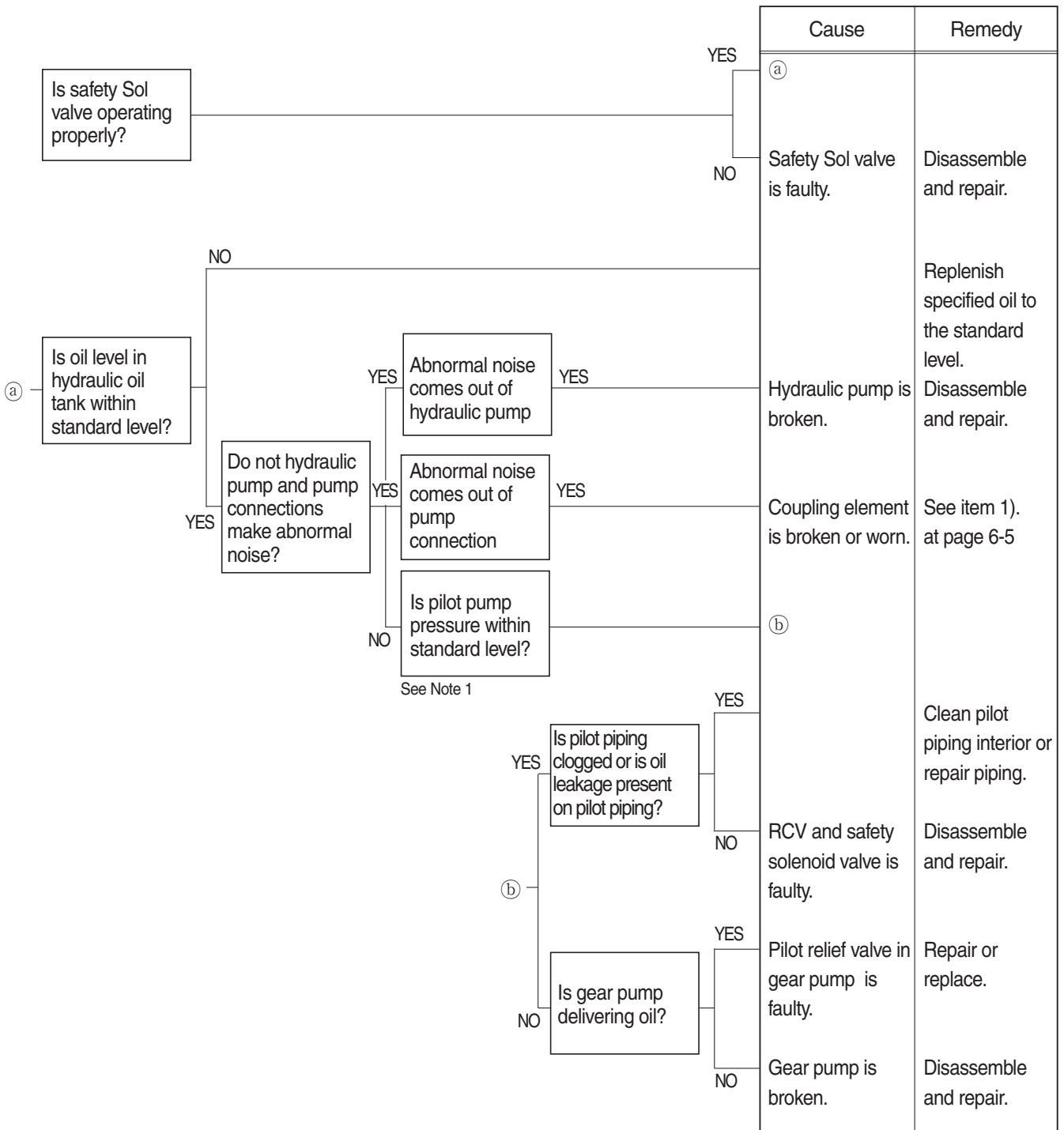

3. HYDRAULIC SYSTEM

1) HYDRAULIC OIL IS CLOUDY

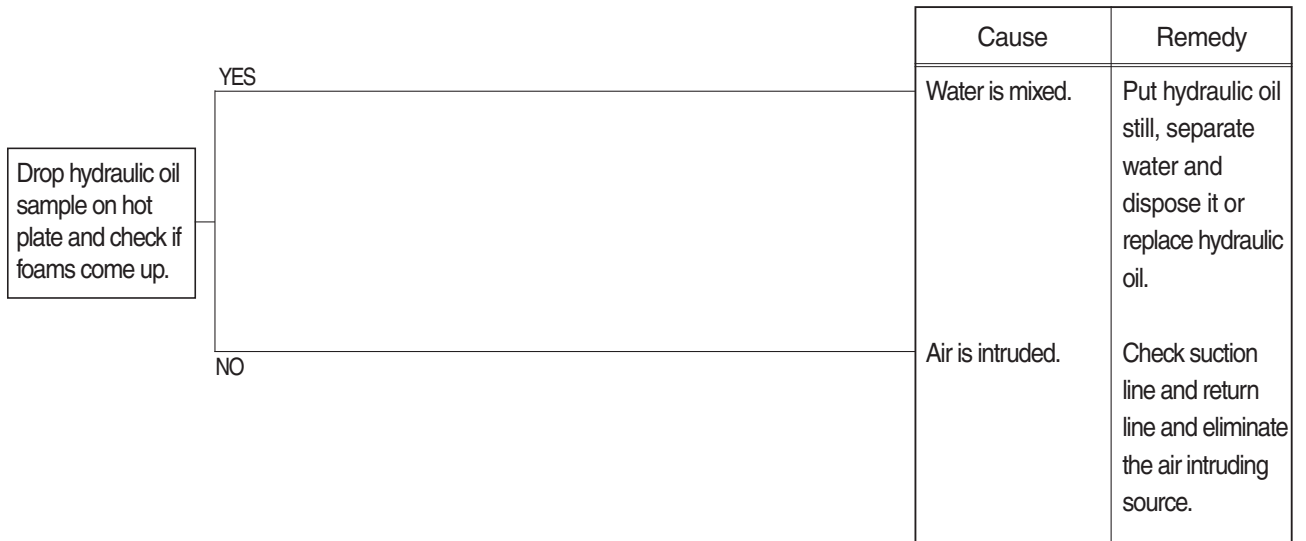

2) HYDRAULIC OIL TEMPERATURE HAS RISEN ABNORMALLY

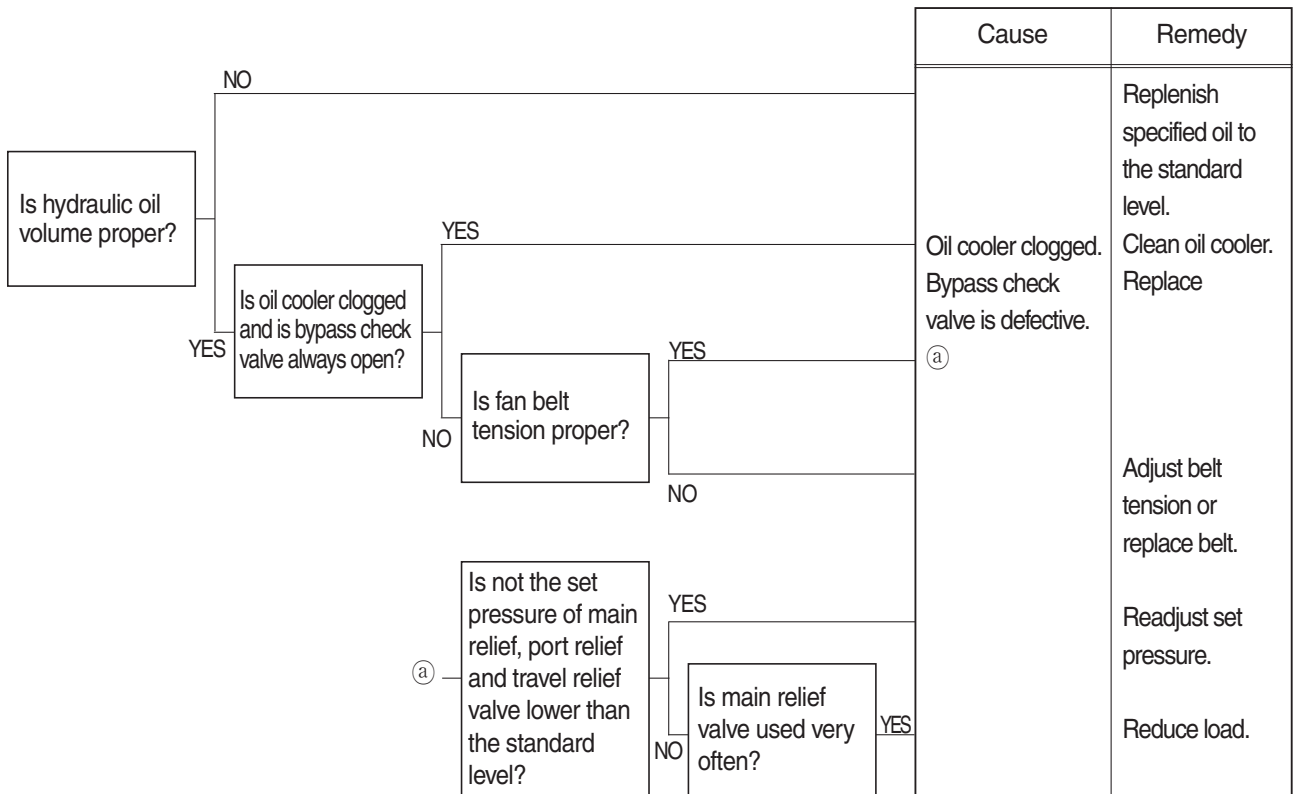

3) CAVITATION OCCURS WITH PUMP

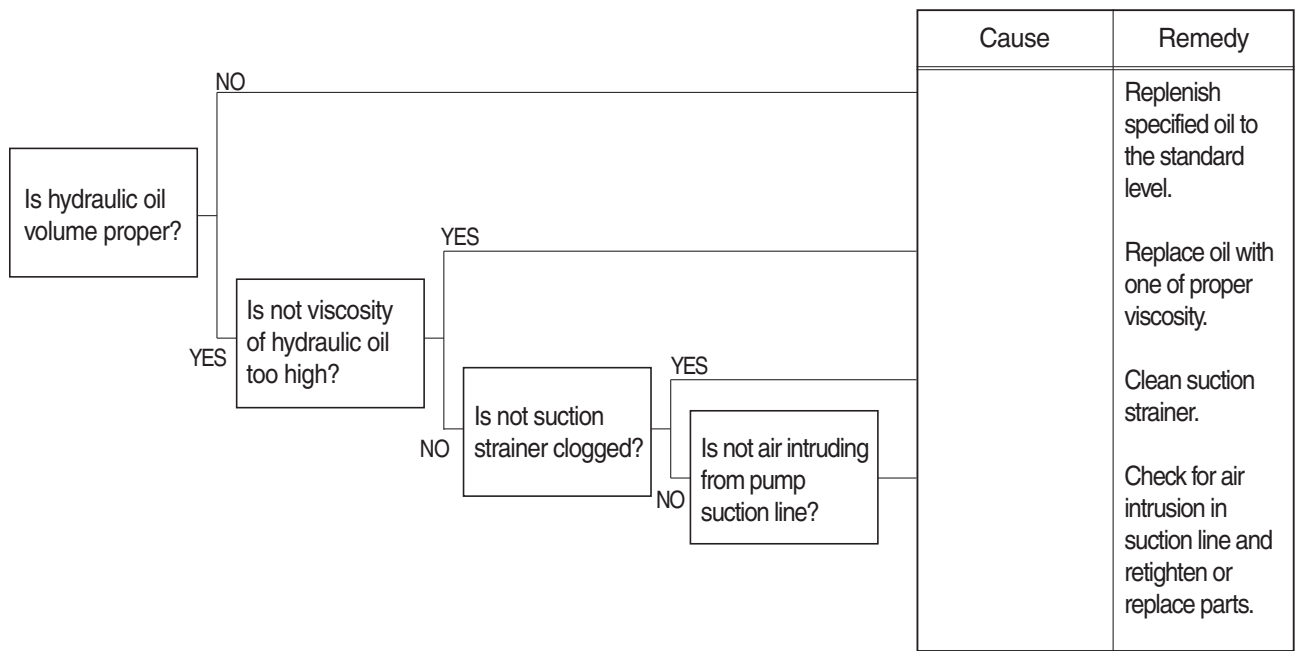

4) HYDRAULIC OIL IS CONTAMINATED

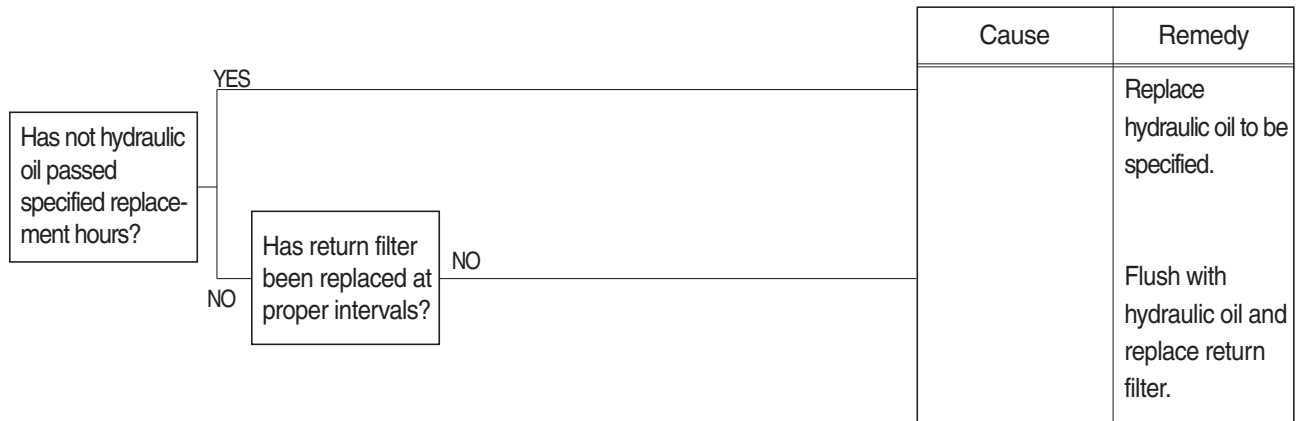

4. SWING SYSTEM

1) BOTH LH AND RH SWING ACTIONS ARE IMPOSSIBLE

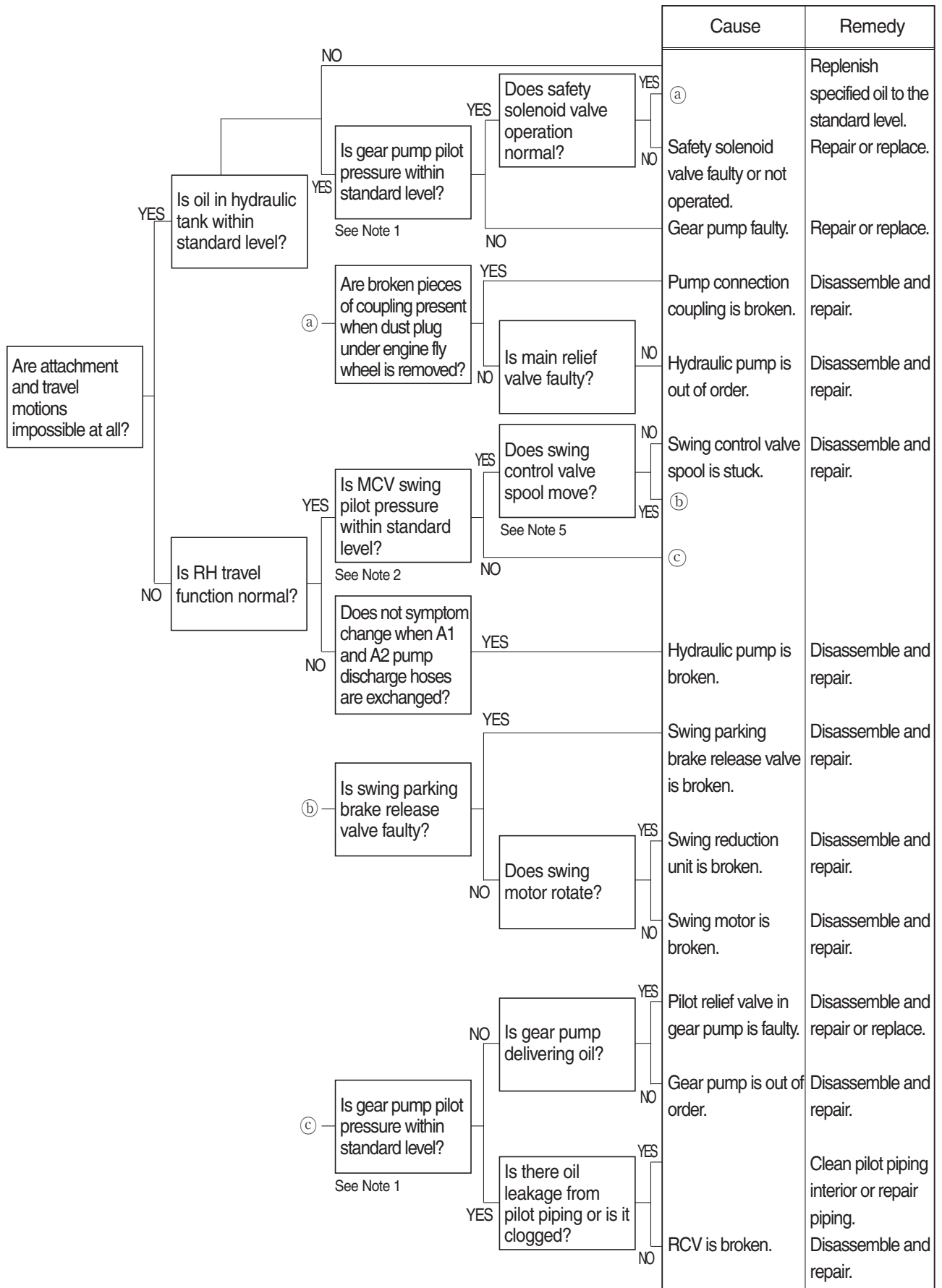

2) SWING SPEED IS LOW

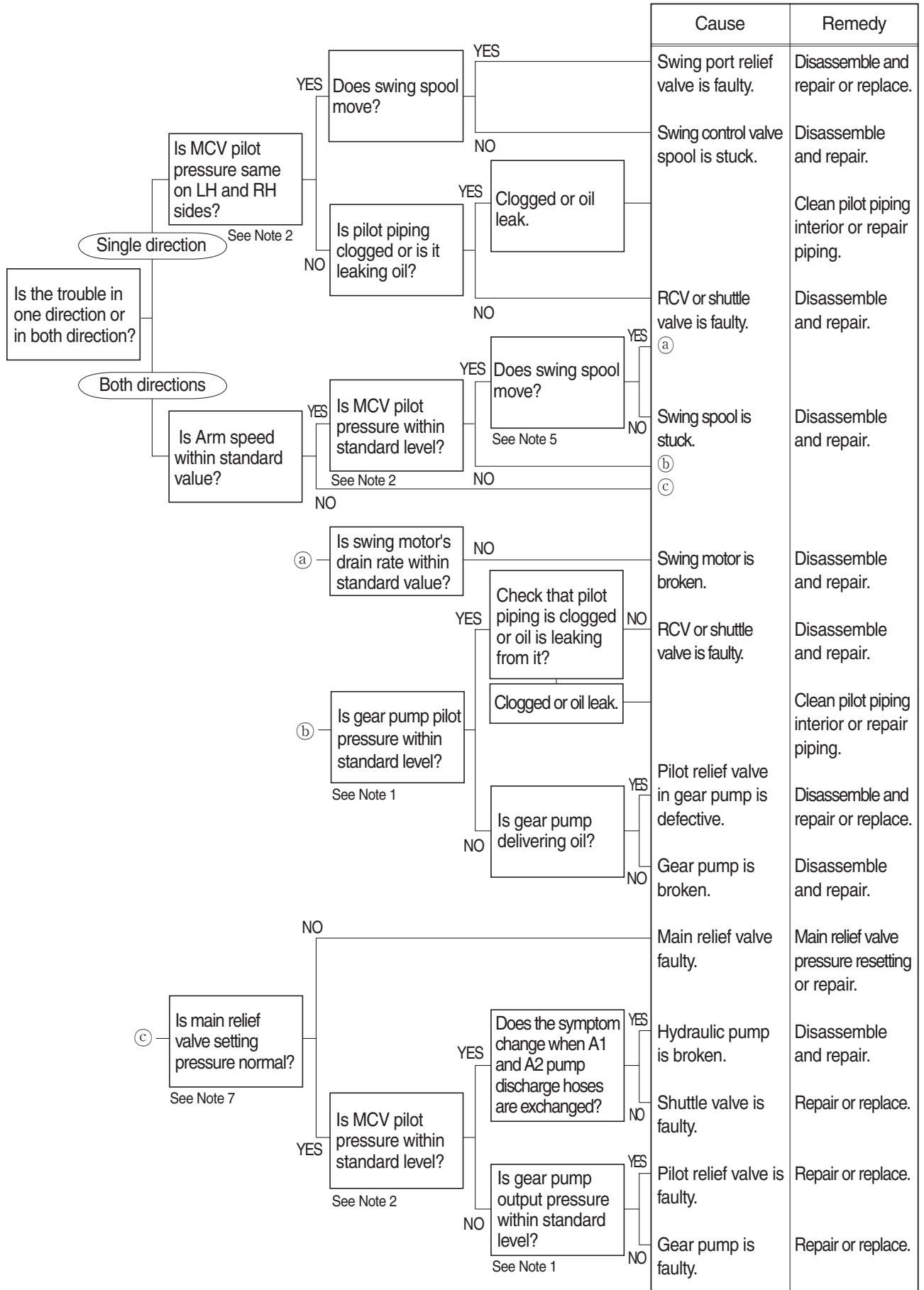

3) SWING MOTION IS IMPOSSIBLE IN ONE DIRECTION

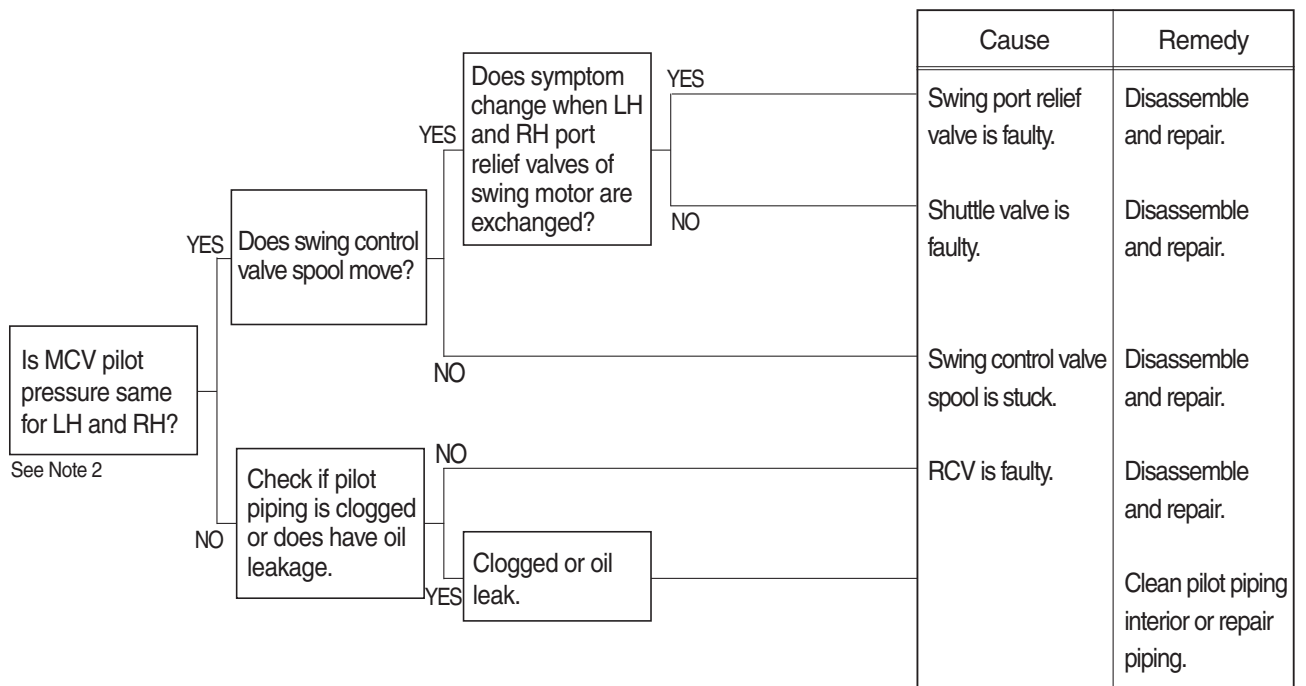

4) MACHINE SWINGS BUT DOES NOT STOP

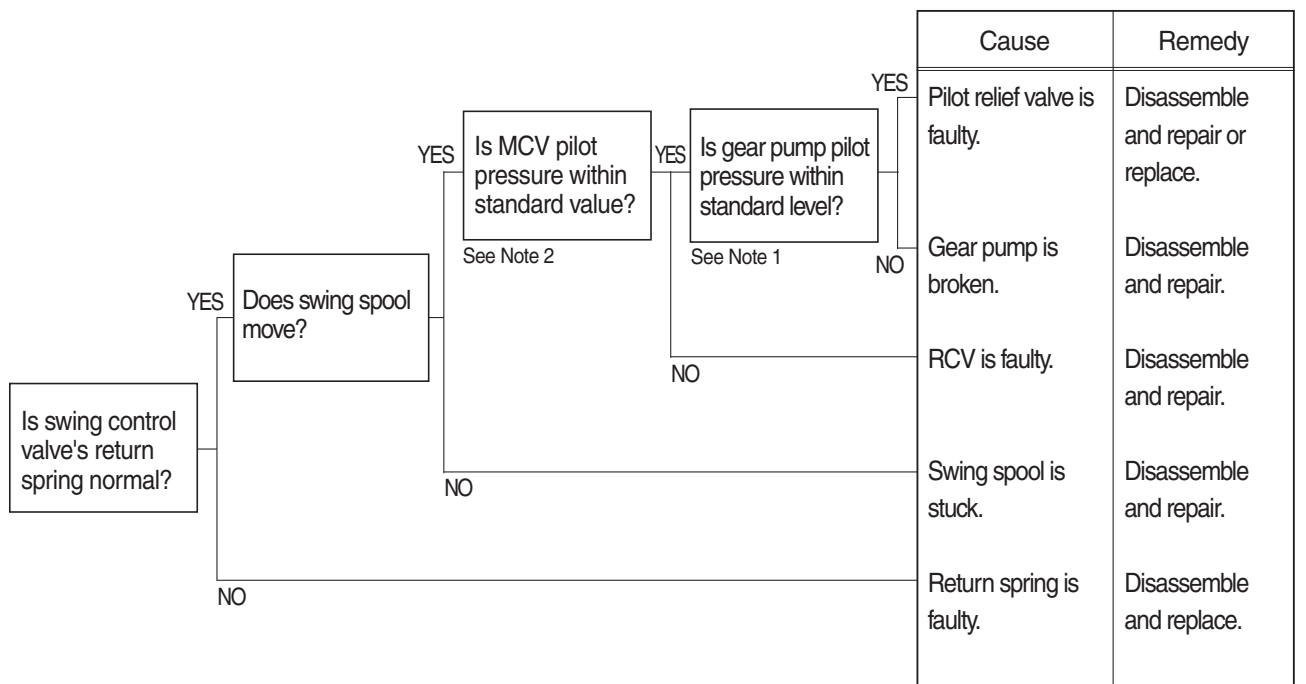

5) THE SWING UNIT DRIFTS WHEN THE MACHINE IS AT REST ON A SLOPE

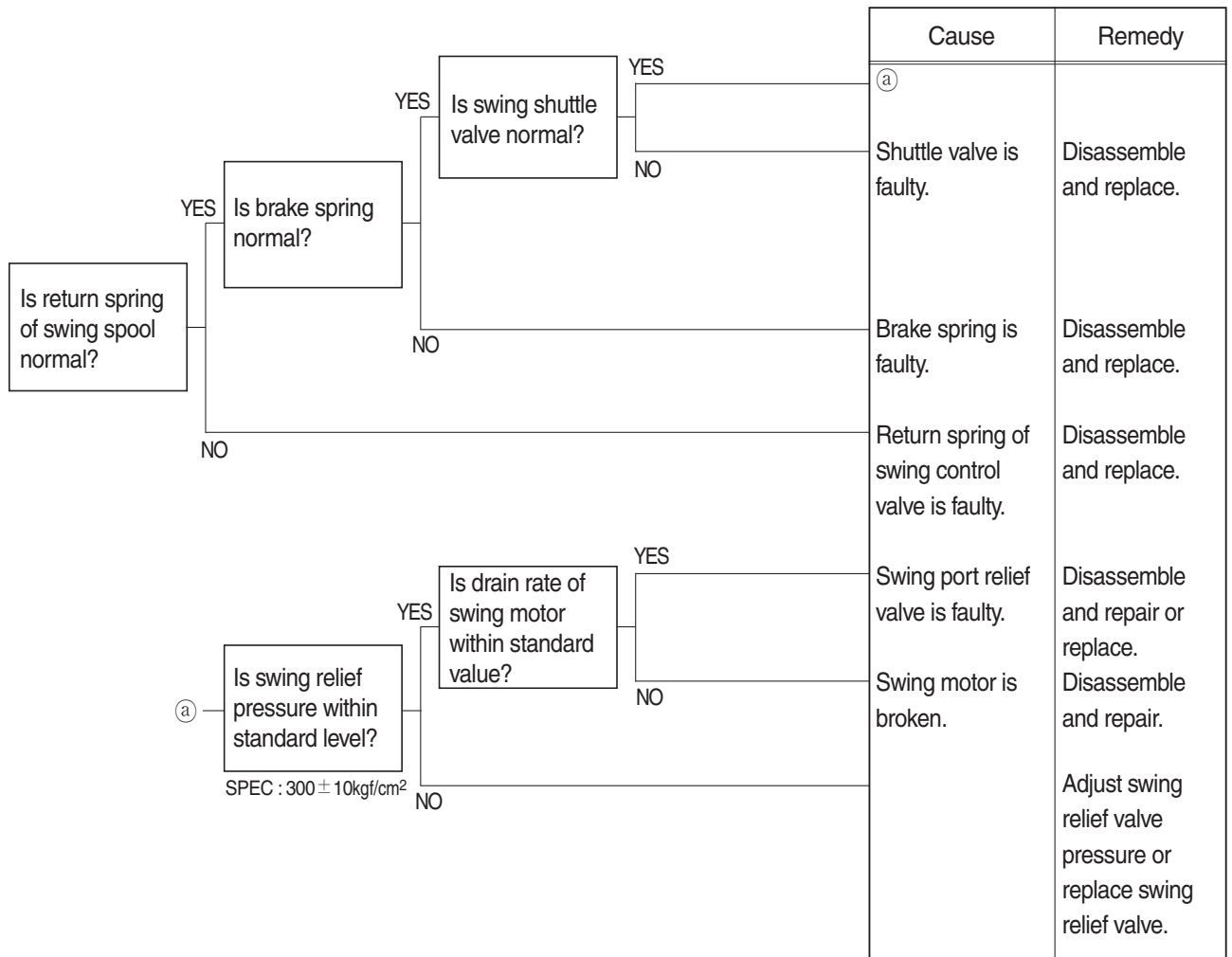

6) LARGE SHOCK OCCURS WHEN STOP SWINGING

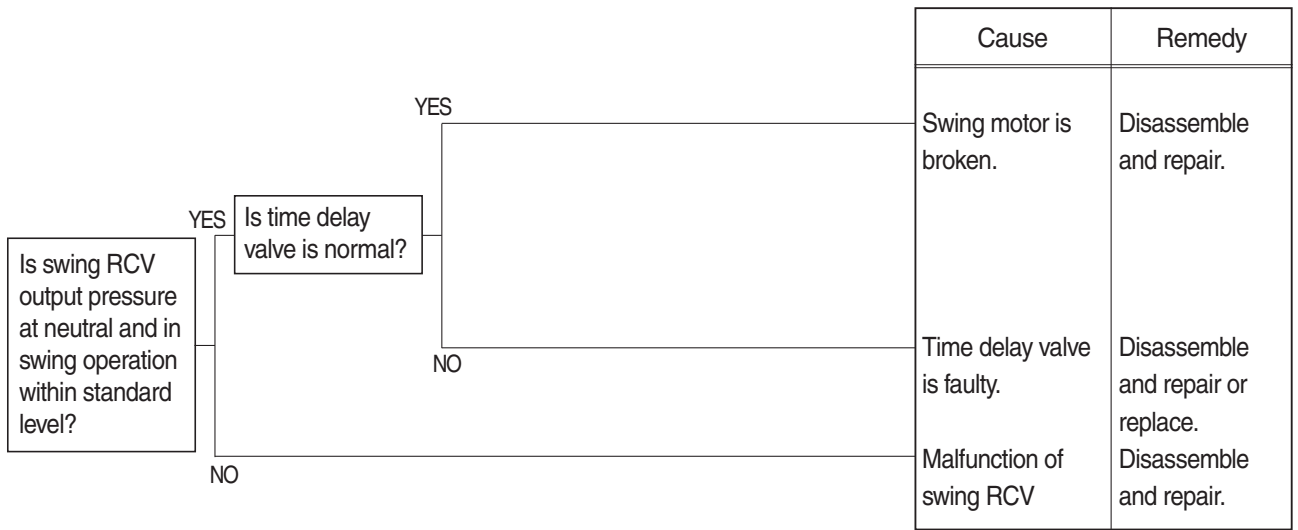

7) LARGE SOUND OCCURS WHEN STOP SWINGING

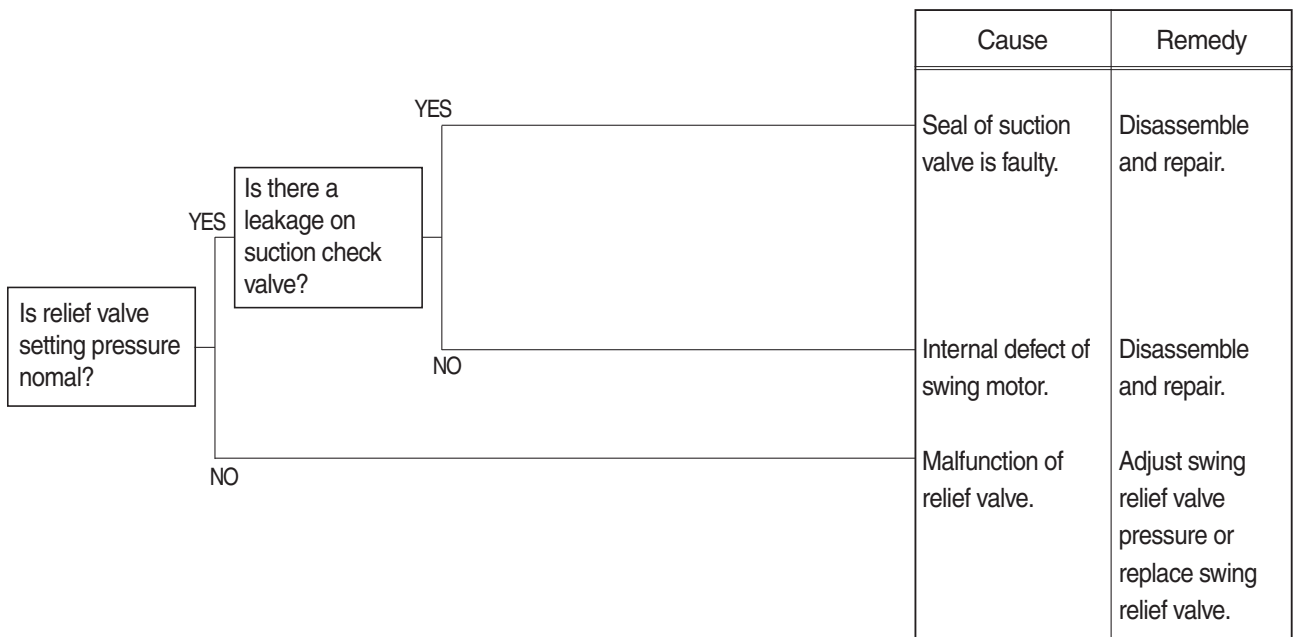

5. TRAVEL SYSTEM

1) TRAVEL DOES NOT FUNCTION

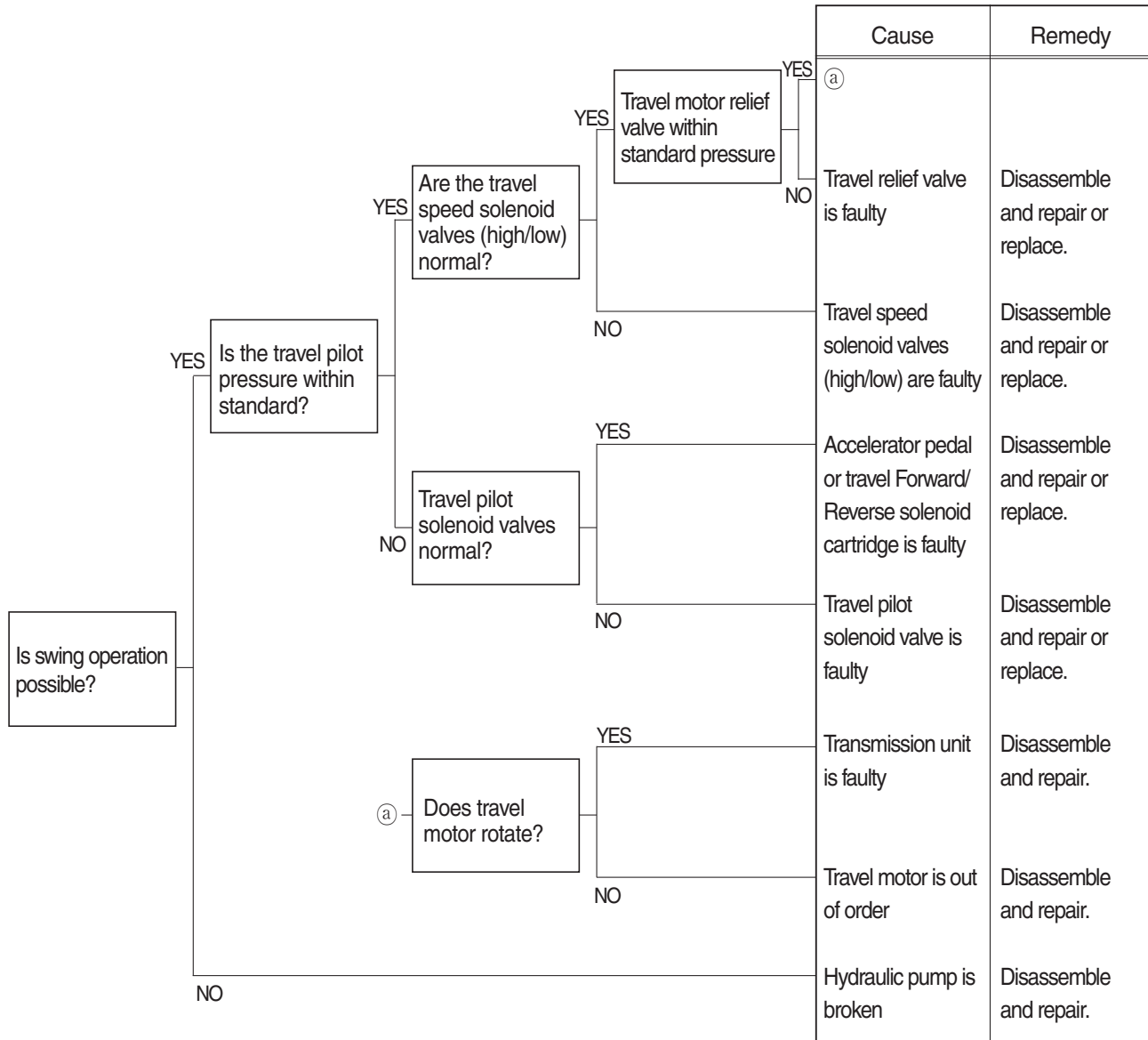

2) TRAVEL ACTION IS POWERLESS (travel only)

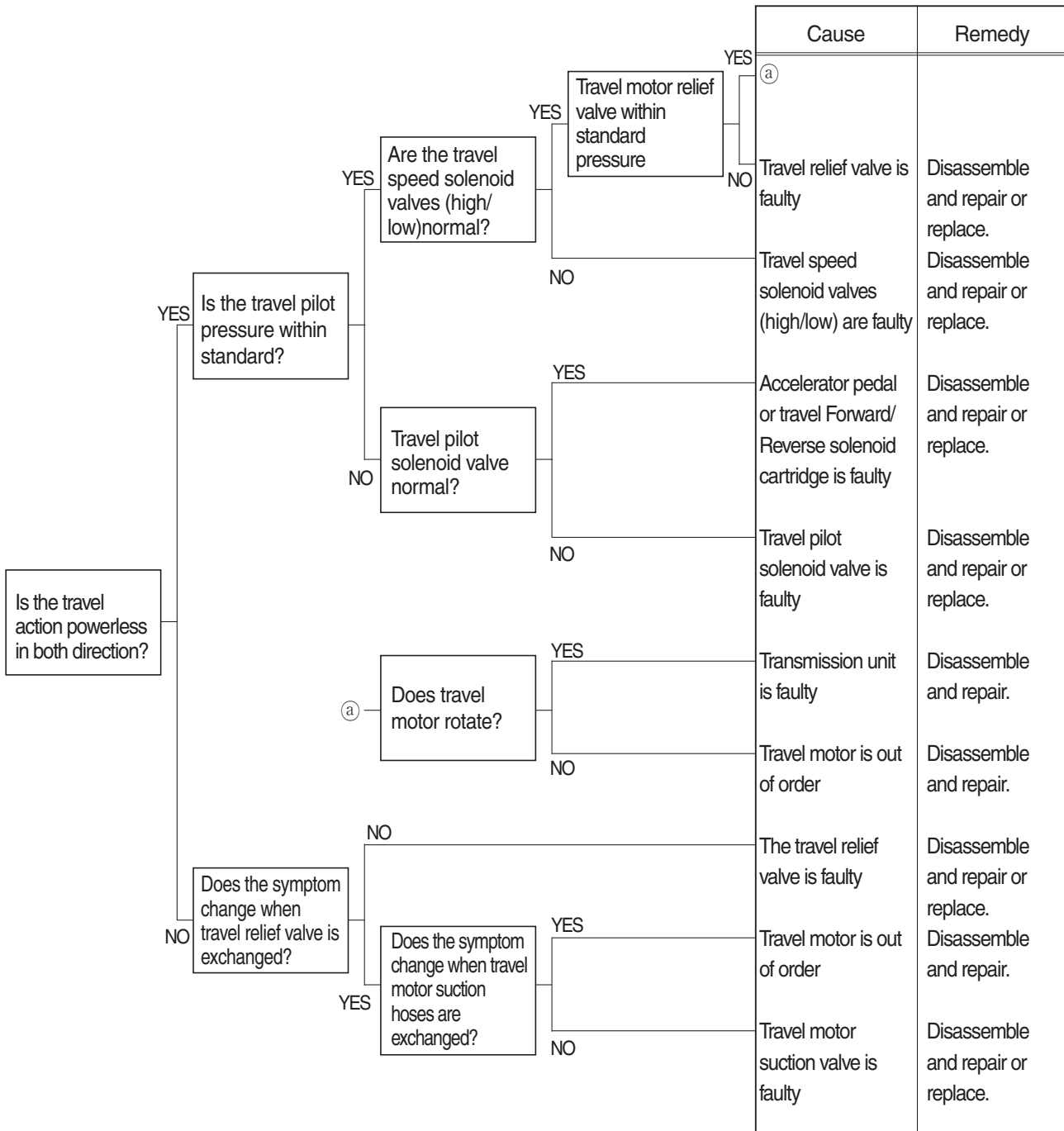

3) THE HYDRAULIC MOTOR DOES NOT GET STARTED

	Cause	Remedy
<p>The hydraulic motor does not get started</p>	<p>The spool does not work properly. (The spool keeps fully open)</p>	<p>Screw the fitting bolts one more time with correct tightening torque. If the spool turns out to be damaged, it should be repaired or the new one should be used</p>
	<p>The anti-avitation check valve does not work properly. (The check valve is kept open.)</p>	<p>Ditto</p>

4) IT TAKES TIME TO ACCELERATE THE MOTOR

	Cause	Remedy
<p>It takes time to accelerate the motor</p>	<p>The spool does not work properly.</p>	<p>Screw the fitting bolts one more time with correct tightening torque. If the spool turns out to be damaged, it should be repaired, or the new one should be used.</p>
	<p>The orifice for closing the counterbalance is clogged.</p>	<p>Remove the foreign matter by disassembling and cleaning.</p>
	<p>Wrong setting of pressure of the relief valve.</p>	<p>Adjust at the correct value. If the relief valve turns out to be out of order, the new one should be used.</p>

5) IT IS NOT POSSIBLE TO REDUCE THE MOTOR SMOOTHLY

It is not possible to reduce the motor smoothly

Cause	Remedy
The orifice for closing the counterbalance is clogged. The opening of the neutral position of the spool is clogged.	Remove the foreign matter by disassembling and cleaning.
Wrong setting of pressure of the relief valve.	Adjust at the correct value. If the relief valve turns out to be out of order, the new one should be used.

6) EXTRAORDINARY NOISE IS HEARD WHEN SUDDENLY REDUCING THE SPEED FROM THE HIGH-SPEED MODE

It takes time to accelerate the motor

Cause	Remedy
The anti-cavitation valve does not work properly.	Screw the fitting bolts one more time with correct tightening torque. If the valve turns out to be damaged, is should be repaired.

6. ATTACHMENT SYSTEM

1) BOOM OR ARM ACTION IS IMPOSSIBLE AT ALL

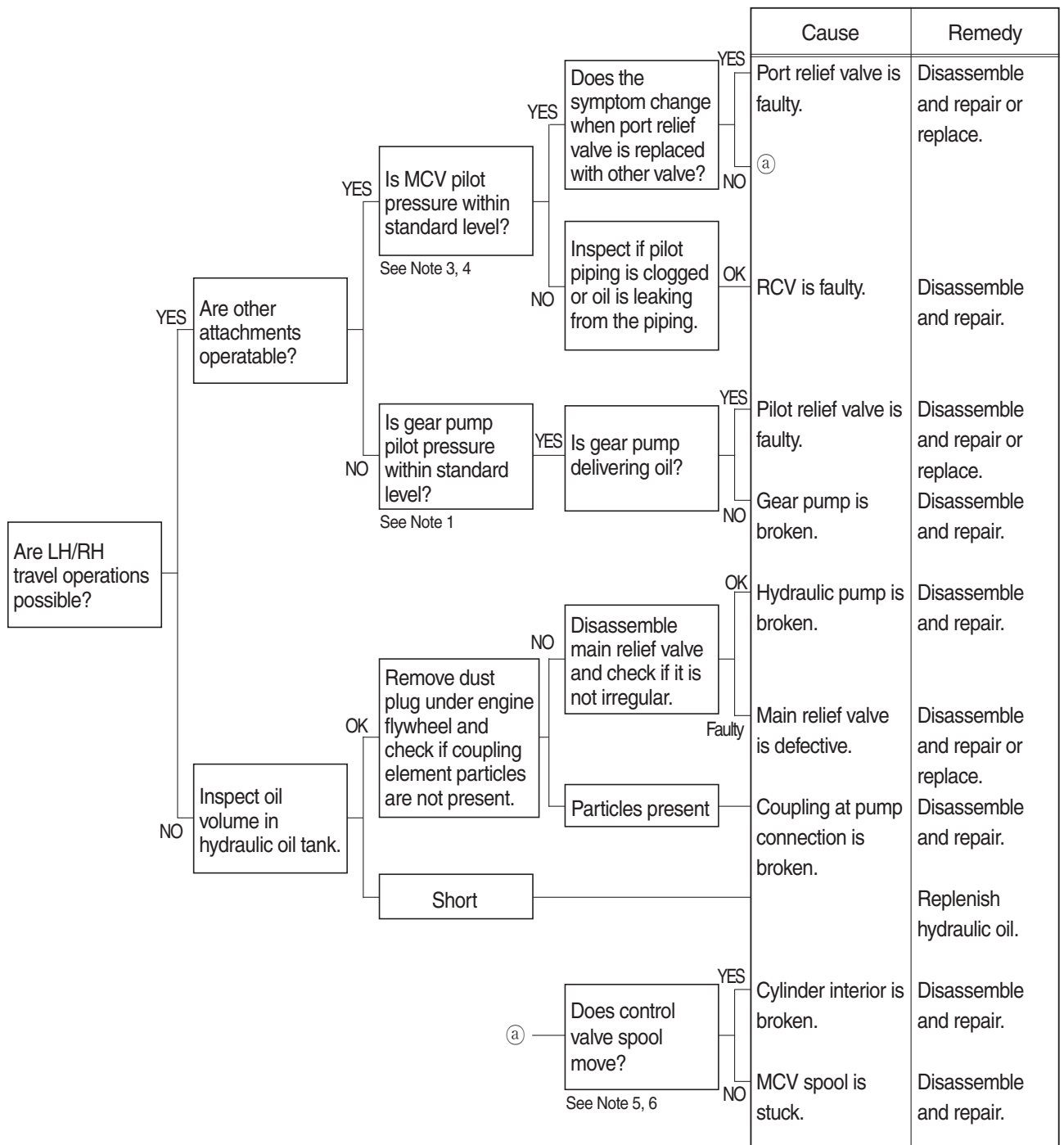

2) BOOM, ARM OR BUCKET SPEED IS LOW

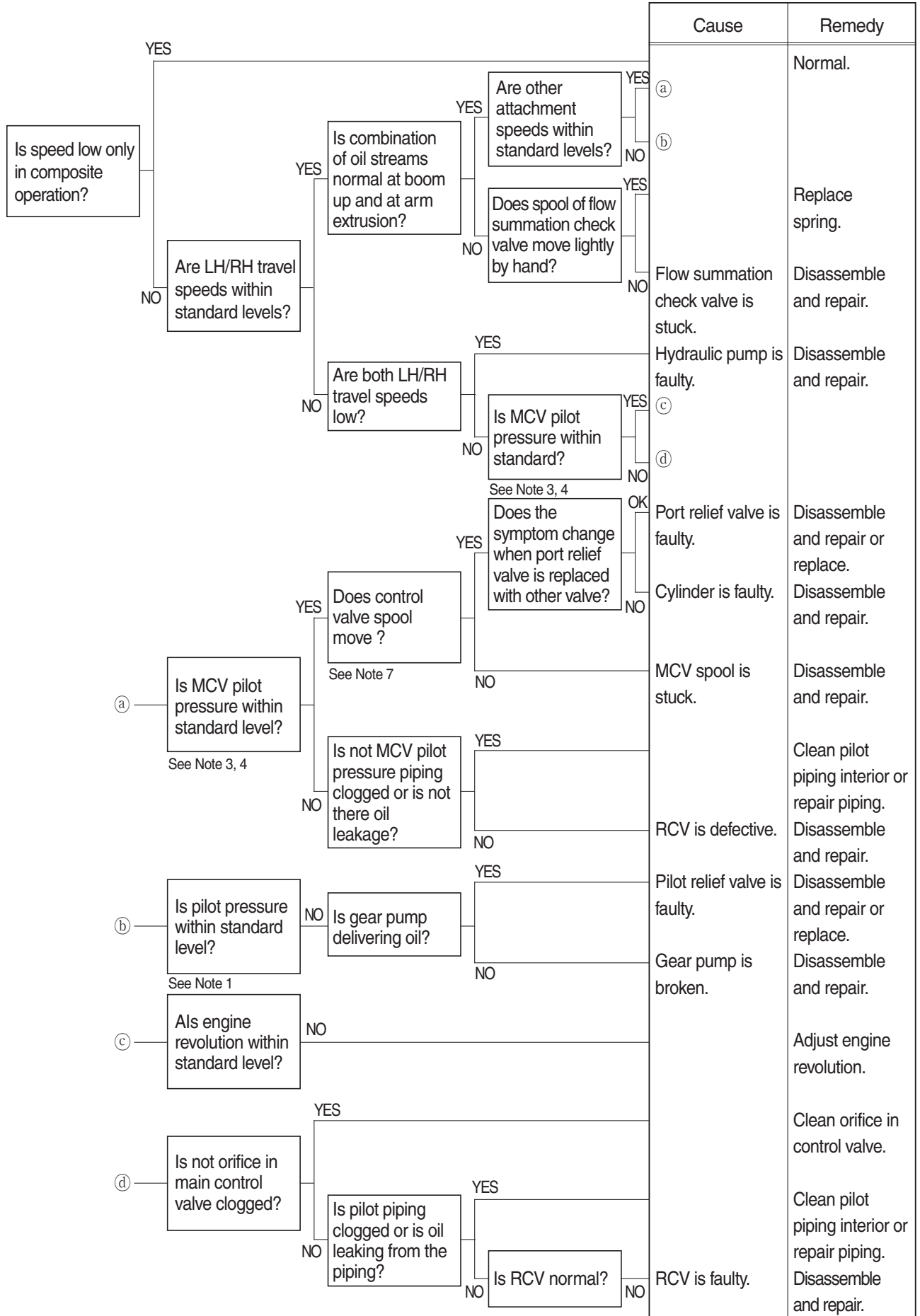

3) BOOM, ARM OR BUCKET CYLINDER EXTENDS OR CONTRACTS ITSELF AND ATTACHMENT FALLS

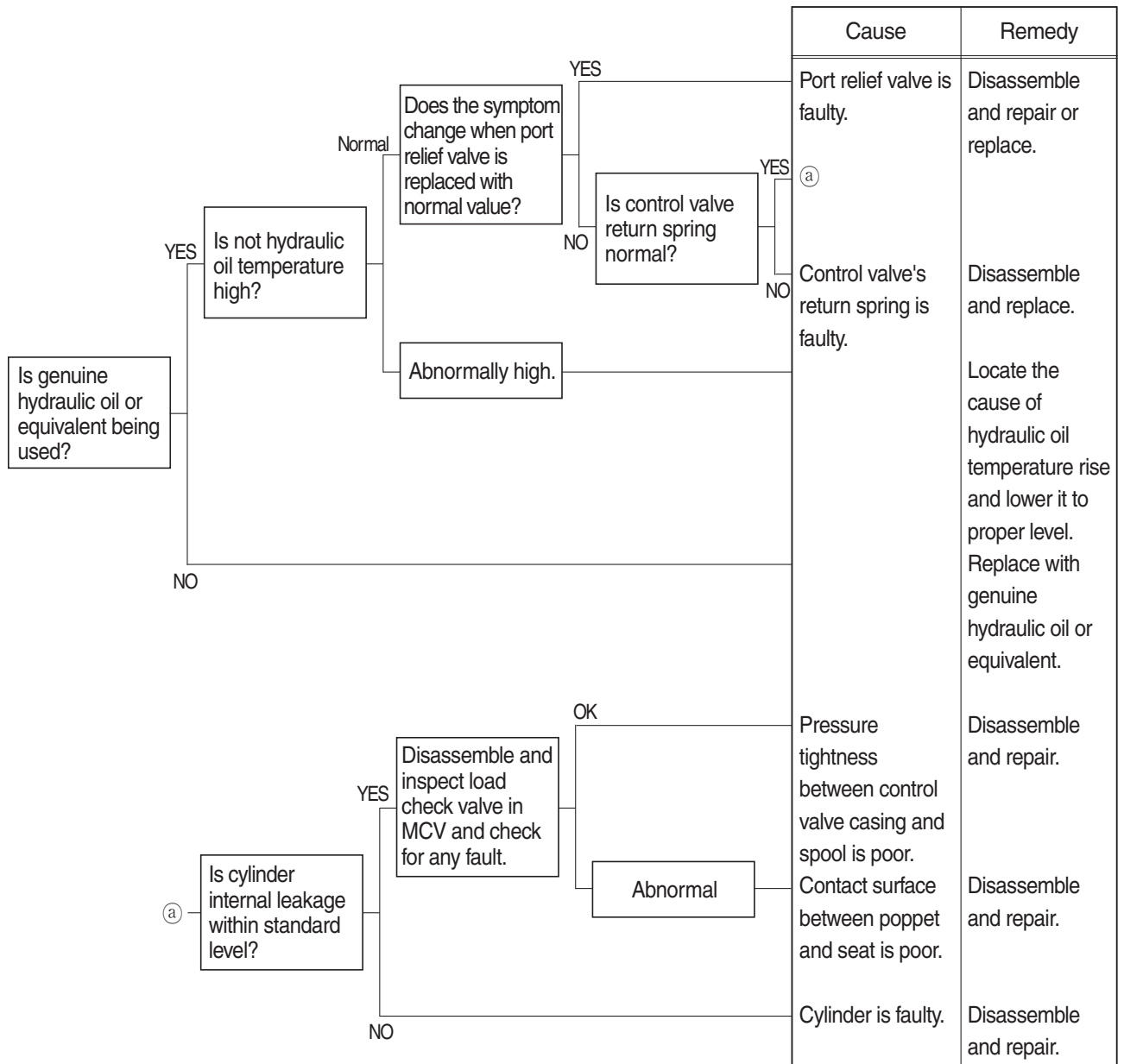

4) BOOM, ARM OR BUCKET POWER IS WEAK

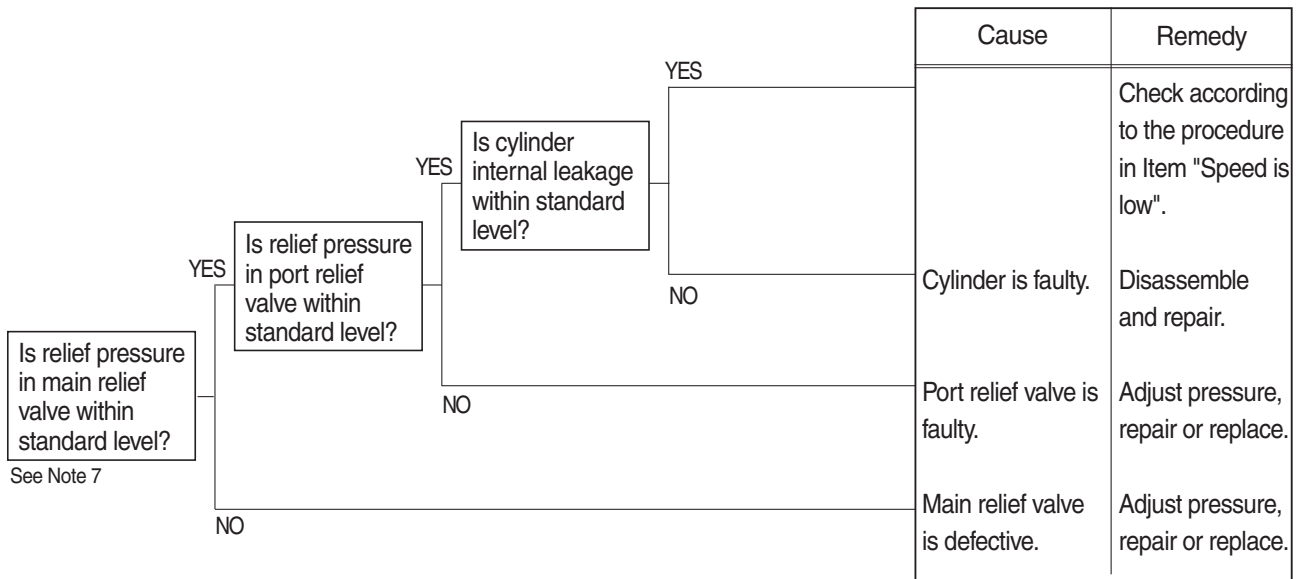

5) ONLY BUCKET OPERATION IS TOTALLY IMPOSSIBLE

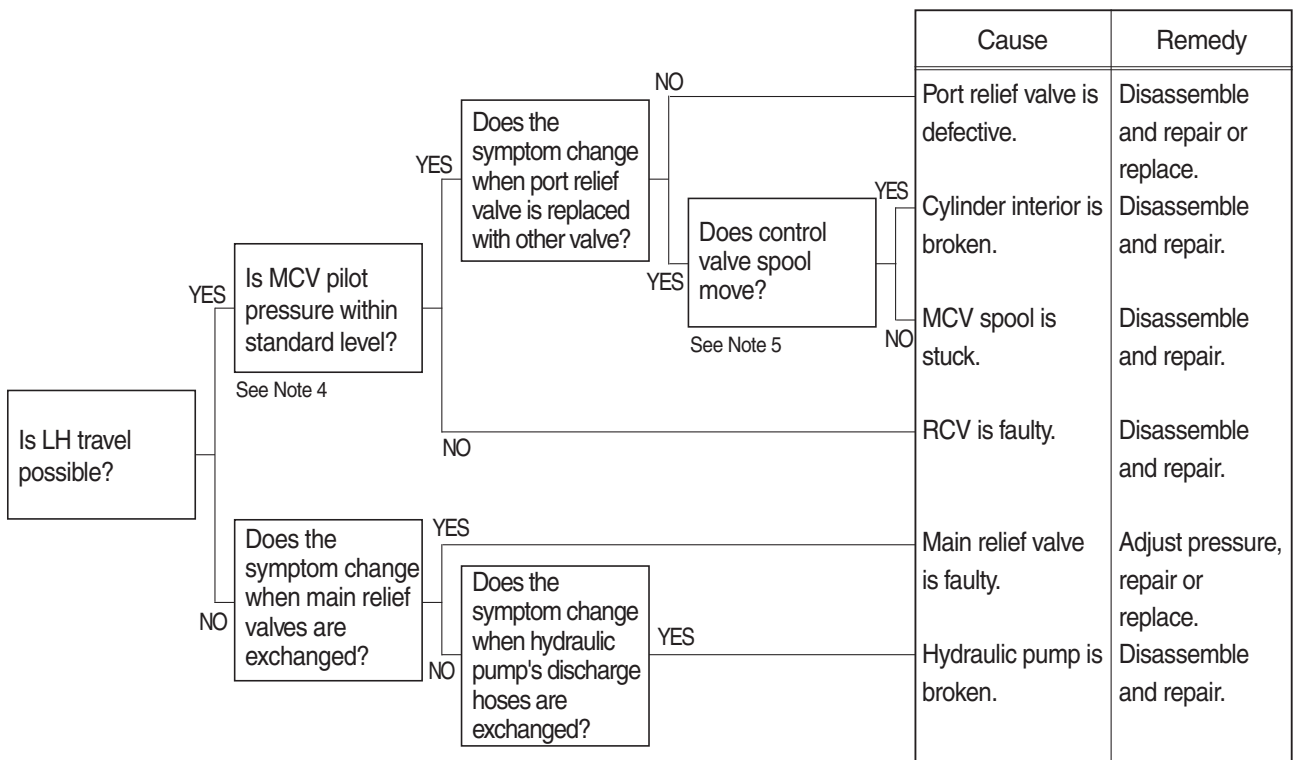

6) BOOM MAKES A SQUEAKING NOISE WHEN BOOM IS OPERATED

<p>Is boom foot pin greased sufficiently?</p>	YES		
	NO	Boom foot pin has run out of grease.	<p>Frictional noise occurs between the sliding faces of boom cylinder's oil seal and boom proper.</p> <p>※ Frictional noise will disappear if they are kept used.</p> <p>Supply grease to it.</p> <p>※ If seizure is in an initial stage, supply sufficient grease. If seizure is in a grown state, correct it by paper lapping or with an oil stone.</p>

7) TIME LAG OF MACHINE WORKING IS LARGE.

<p>Is overload relief valve for each spool working properly?</p>	YES		Refer to 2)
	NO	Overload relief valve is faulty.	Disassemble and repair.

※ HOW TO CHECK INTERNAL BOOM CYLINDER LEAKAGE

1. Lower the bucket teeth to the ground with bucket cylinder fully retracted and arm cylinder rod retracted almost in full.

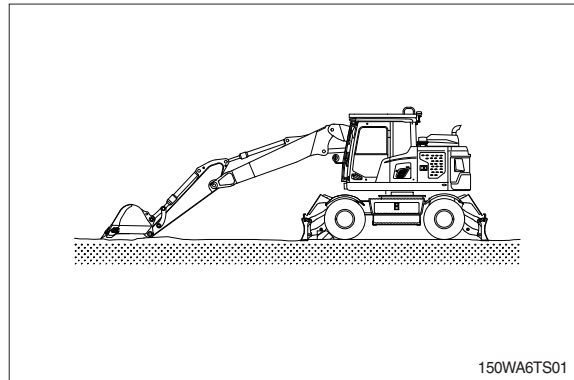

2. Disconnect hose (A) from rod side of boom cylinder and drain oil from cylinders and hose. (put cups on piping and hose ends)

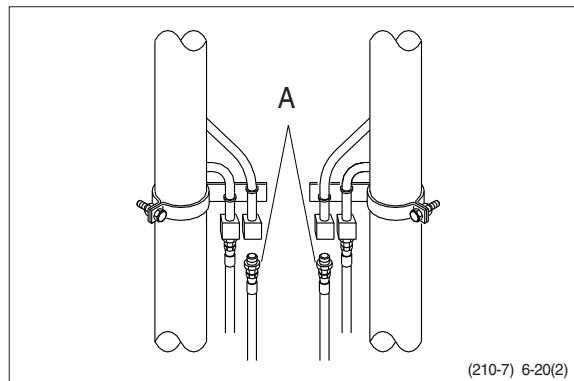

3. Raise bucket OFF the ground by retracting the arm cylinder rod.

If oil leaks from piping side and boom cylinder rod is retracted there is an internal leak in the cylinder.

If no oil leaks from piping side and boom cylinder rod is retracted, there is an internal leak in the control valve.

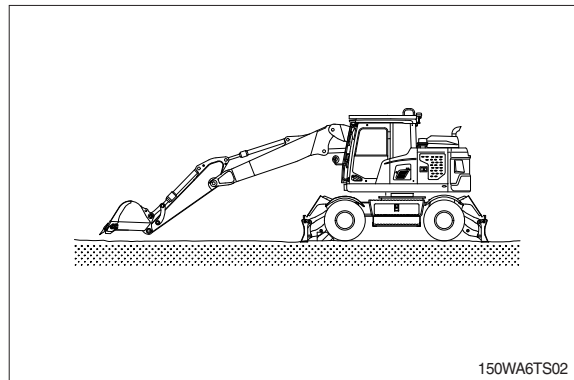

7. FRONT AXLE AND REAR AXLE

Problem	Cause	Correction
Insufficient braking	1. Incorrect adjustment	Inspect disc thickness and if discs are usable readjust brakes to the specifications in the manual.
	2. Brake discs worn out	Inspect disc thickness and replace if necessary.
	3. Incorrect brake fluid	Replace all seals in axle and master cylinder that have made contact with the incorrect fluid and all brake hoses. If incorrect fluid leaked into axle oil, seals and O-rings in axle must be replaced.
	4. Loss of brake fluid	Inspect for and repair any leaks in outside circuit or master cylinder. If caused by incorrect brake fluid see correction No.3. If leak is to the outside replace the O-rings between the center and intermediate housings. If leak is to the inside replace above O-rings and brake piston O-rings.
	5. Overheated axle causing brake fluid to vaporize. (Brake return when axle cools)	See "overheating" problem.
Soft brake pedal	6. Air in brake circuit	Bleed air in brake circuit.
Ineffective safety brake	7. Incorrect adjustment	See correction No.1.
	8. Brake disc worn out	See correction No.2.
Overheating	9. Oil level wrong	Drain, flush and refill oil to proper level.
	10. Too small of a brake gap	Readjust brakes to the specifications.
	11. Park brake dragging	Unlock the brake and adjust the correct gap.
	12. Incorrect brake fluid in system	See correction No.3.
	13. No free-pedal at master cylinder	Readjust brake pedal.
	14. Restriction in brake lines	Inspect for and replace damage lines.
15. Restriction in return line of brake servo system	Inspect for and replace damaged return line. Inspect for and remove any filter, tee'd in line or any other source of back pressure from the return line.	
16. Incorrect lubricant	Change the retaining rings of the brake circuit and brake pump.	
Diff-lock inoperative	17. If manual control, loose or misadjusted linkage	Inspect and correct linkage and readjust.
	18. If hydraulic control, problems in the hydraulic or electrical circuits of the machine.	Refer to the hydraulic or electrical section in this manual.
	19. If hydraulic control problems in actuating cylinder (noteable through loss of hydraulic oil or increase of the oil level in axle)	Rebuilt cylinder.
	20. If with limit slip differential, worn discs	Replace discs.

Problem	Cause	Correction
Oil coming out of breather	21. Leak in internal brake system 22. Leak in diff-lock actuating cylinder	See correction No.2 and No.3. See correction No.19.
Nospin indexing noise when driving straight ※ With nospin, fatigue damage can occur on the side with the larger tire.	23. Unequal tire pressure left and right 24. Different style, size or brand of tires between left and right hand side	Inflate tires to the recommended pressure in this manual, or until the rolling radius is equal. Change tires to make the rolling radius equal. Vary the tire pressure within the specifications until the rolling radius is equal.
Noise during coast and under power the same	25. Wheel bearings damaged	Replace and adjust
Noise under power greater than during coast	26. Low oil level 27. Incorrect lubricant 28. Ring and pinion worn 29. Worn ring and pinion bearings 30. Worn planetary gears or bearings	Refill oil to proper level See correction No.16. Inspect through top cover. Replace and adjust. Replace and adjust Replace.
Noise during coast greater than under power	31. Loose pinion nut 32. Only pinion bearing damaged	Inspect ring, pinion and pinion bearings. If undamaged, retighten nut. See correction No.29.
Noise during turn (Without nospin)	33. Worn spider and/or side gears	Replace.
A stick slip noise when going from forward to reverse	34. Worn or damaged cardan shaft 35. Loose wheel 36. Articulation box joint and achsel shaft damaged 37. Spider pins loose in diff-carrier 38. Damaged or missing spider and/or side gear washers	Inspect and replace. Inspect for wheel and wheel stud damage. Replace if needed and retorque lugnuts. Inspect and replace. Inspect through top cover. Replace. See correction No.33.

GROUP 3 ELECTRICAL SYSTEM

1. WHEN STARTING SWITCH IS TURNED ON, MONITOR PANEL DISPLAY DOES NOT APPEAR

- Before disconnecting the connector, always turn the starting switch OFF.
- Before carrying out below procedure, check all the related connectors are properly inserted and short of fuse No. 12, 16.
- After checking, insert the disconnected connectors again immediately unless otherwise specified.

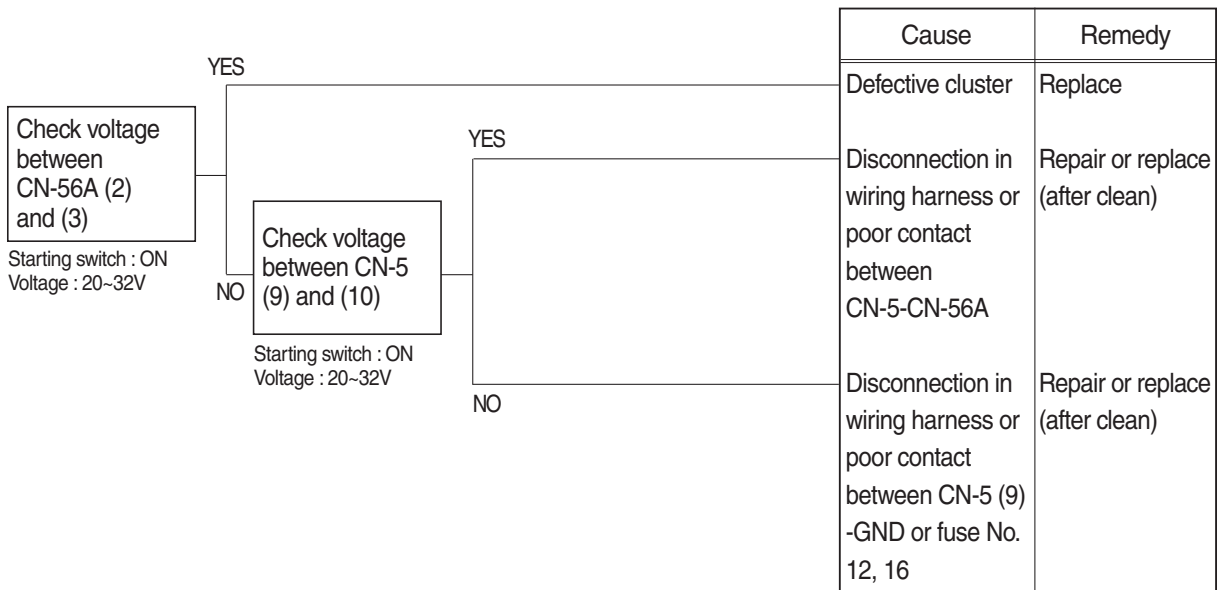

Check voltage

YES	20~32V
NO	0V

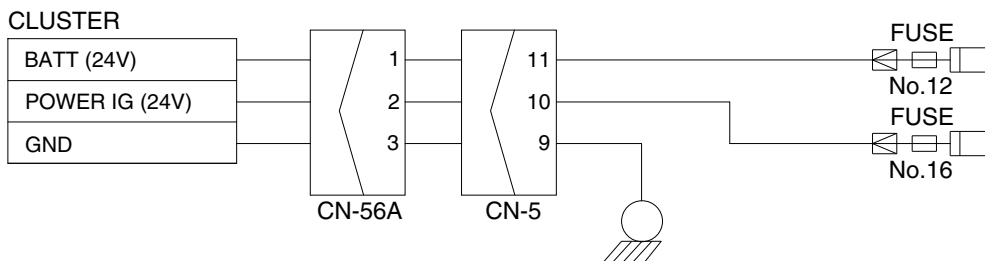

2. COMMUNICATION ERROR FLASHES ON THE CLUSTER (HCESPN 840, FMI 2)

- Before disconnecting the connector, always turn the starting switch OFF.
- Before carrying out below procedure, check all the related connectors are properly inserted.
- After checking, insert the disconnected connectors again immediately unless otherwise specified.

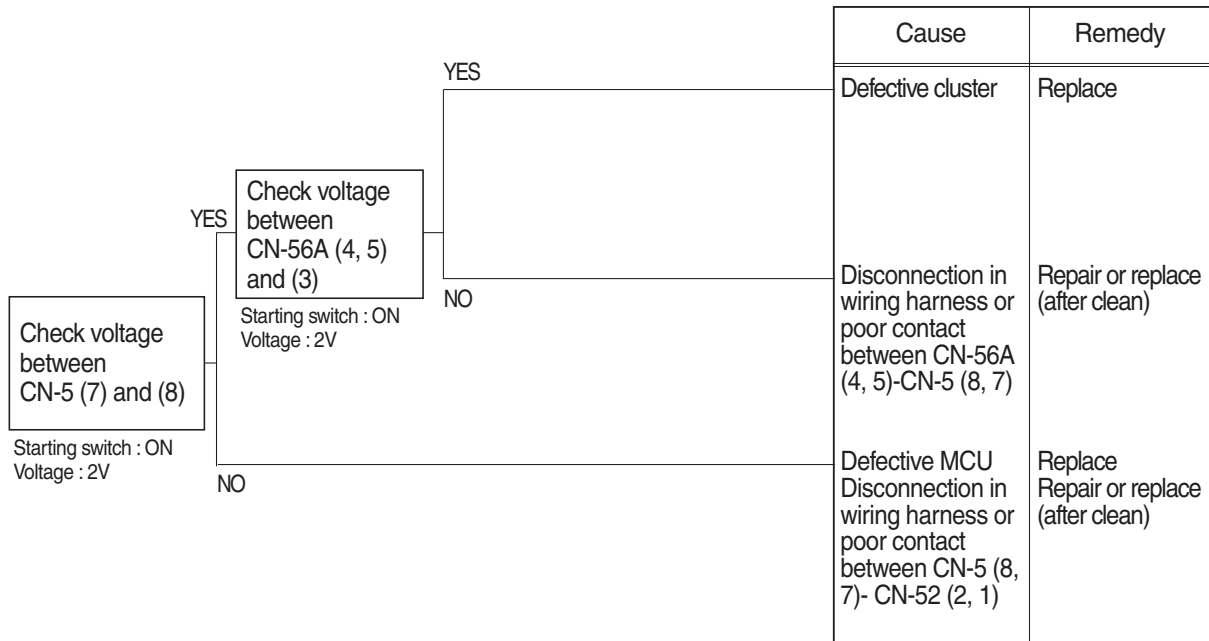

Check voltage

YES	2V
NO	0V

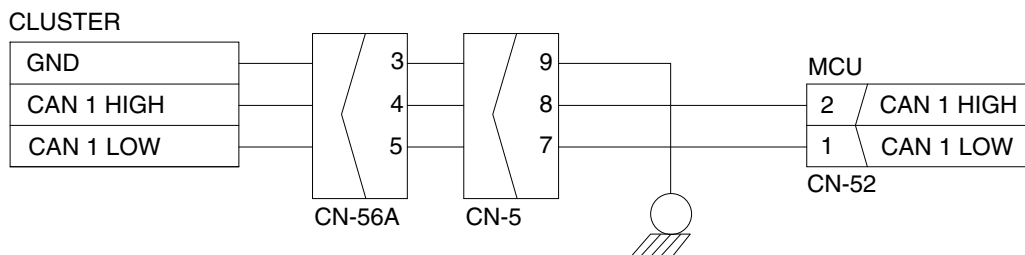

3. BATTERY CHARGING WARNING LAMP LIGHTS UP (Starting switch : ON)

- Before disconnecting the connector, always turn the starting switch OFF.
- Before carrying out below procedure, check all the related connectors are properly inserted.
- After checking, insert the disconnected connectors again immediately unless otherwise specified.

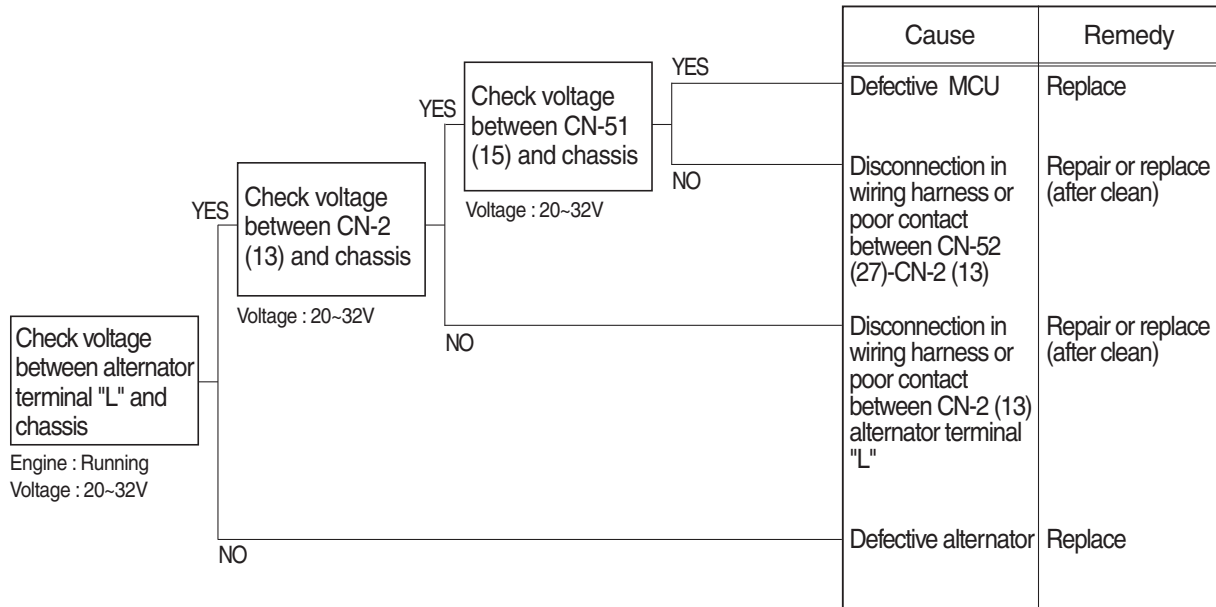

Check voltage

YES	20~32V
NO	0V

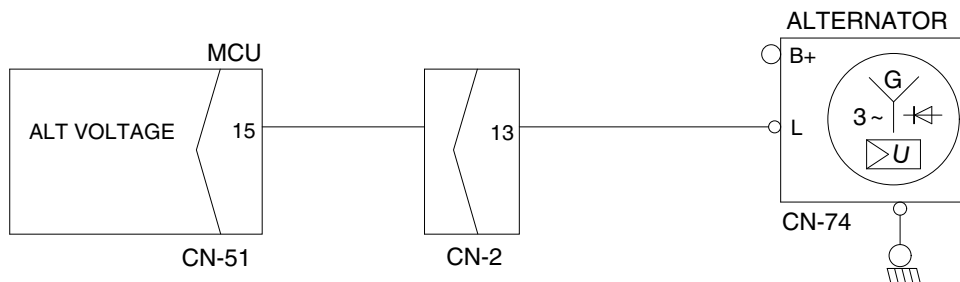

140WA6ES03

4. WHEN COOLANT OVERHEAT WARNING LAMP LIGHTS UP (engine is started)

- Before disconnecting the connector, always turn the starting switch OFF.
- Before carrying out below procedure, check all the related connectors are properly inserted.
- After checking, insert the disconnected connectors again immediately unless otherwise specified.

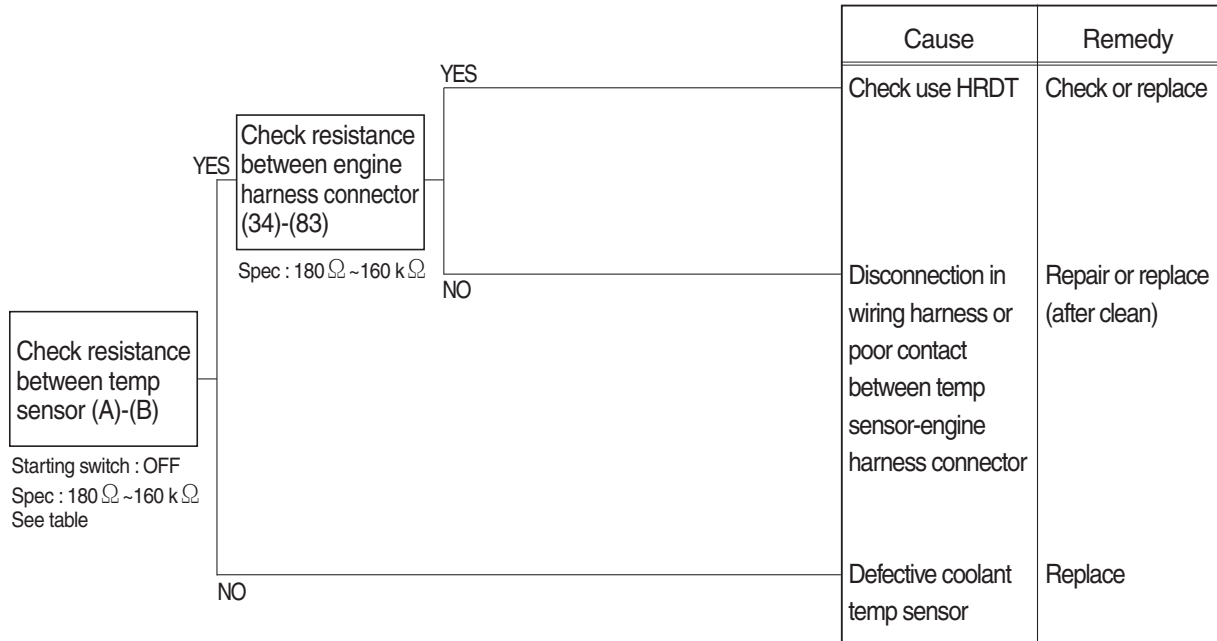

Check Table

Temperature (°C)	0	25	50	80	95
Resistance (kΩ)	30~37	9.3~10.7	3.2~3.8	1.0~1.3	0.7~0.8

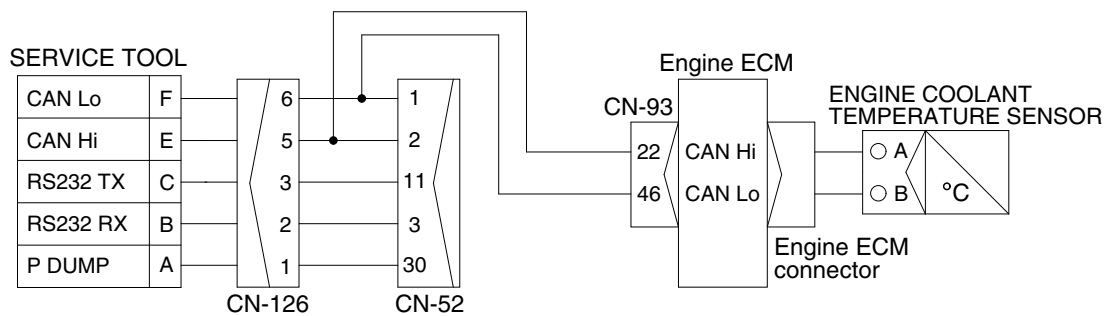

140WA6ES04

5.  **WHEN AIR CLEANER WARNING LAMP LIGHTS UP** (engine is started)

- Before disconnecting the connector, always turn the starting switch OFF.
- Before carrying out below procedure, check all the related connectors are properly inserted.
- After checking, insert the disconnected connectors again immediately unless otherwise specified.

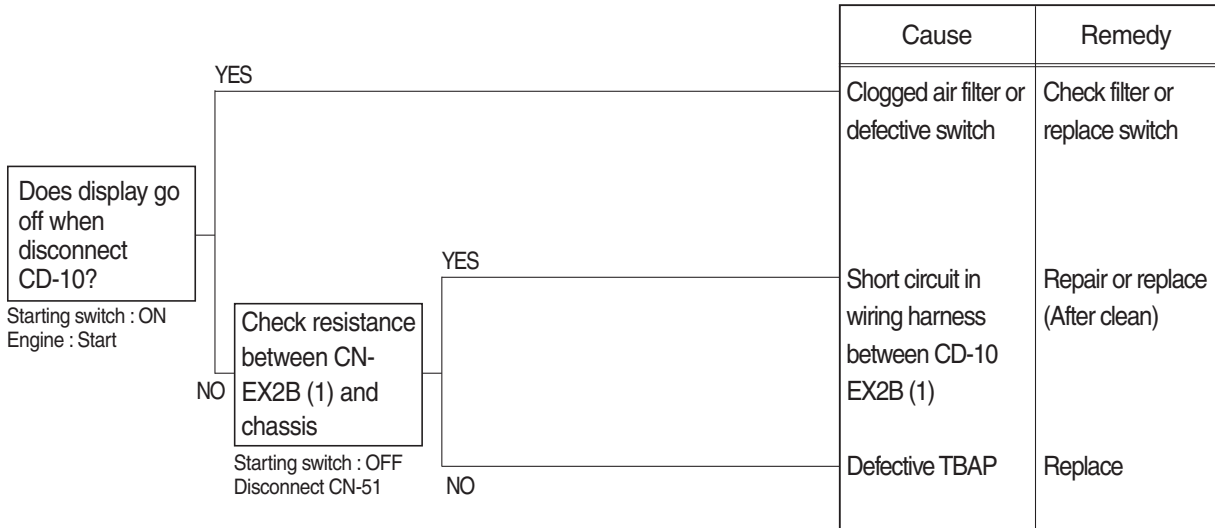

Check resistance

YES	MAX 1Ω
NO	MIN 1MΩ

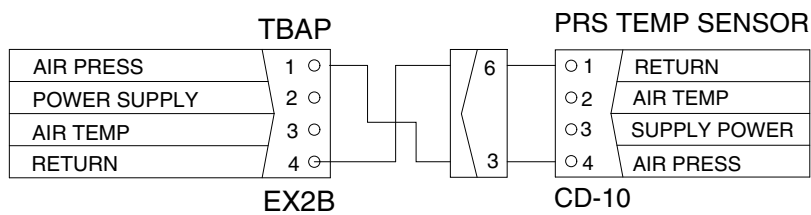

6.  **WHEN ENGINE OIL PRESSURE WARNING LAMP LIGHTS UP** (engine is started)

- Before disconnecting the connector, always turn the starting switch OFF.
- Before carrying out below procedure, check all the related connectors are properly inserted.
- After checking, insert the disconnected connectors again immediately unless otherwise specified.

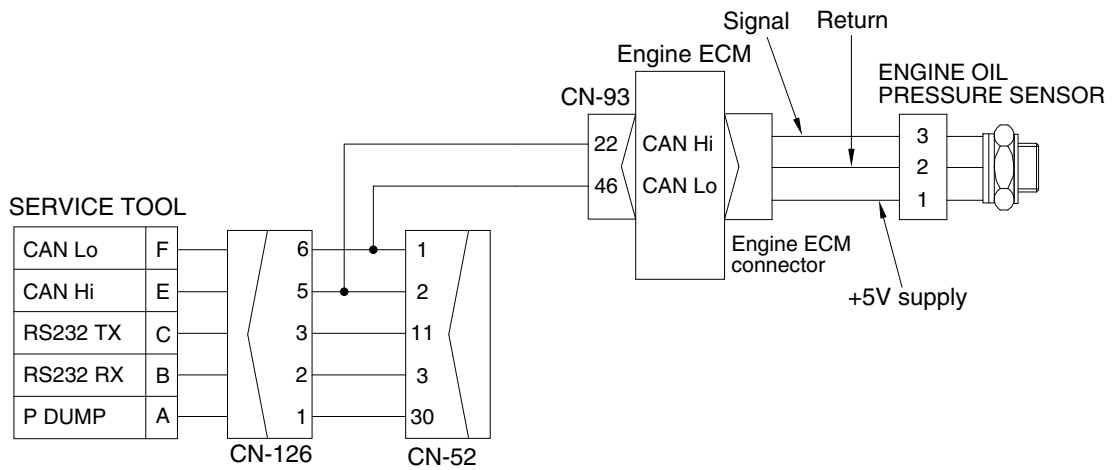
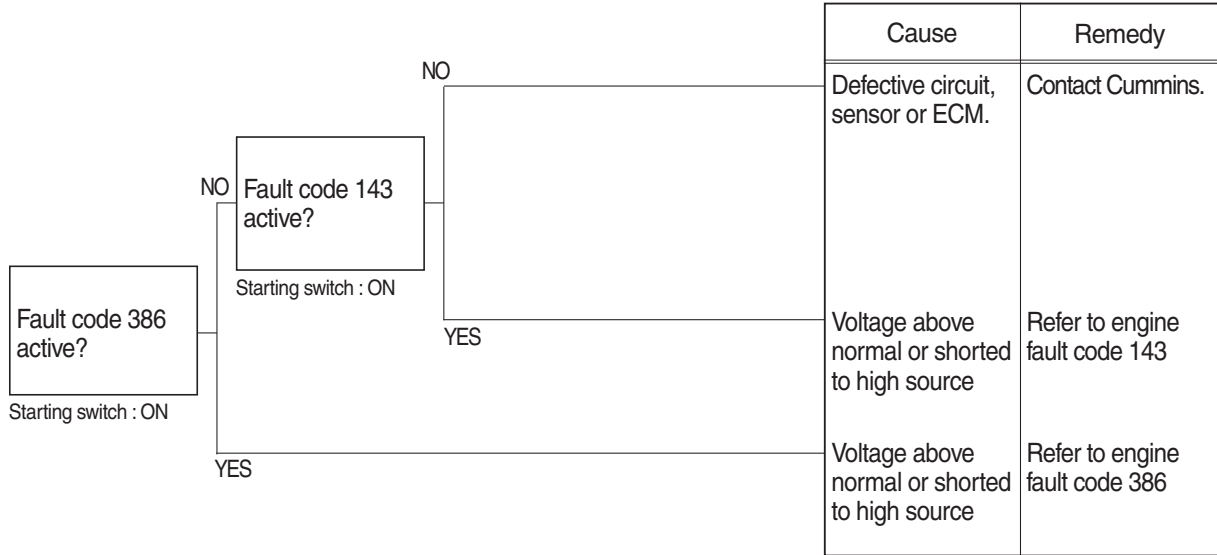

140WA6ES07

7. WHEN HYDRAULIC OIL TEMPERATURE WARNING LAMP LIGHTS UP (engine is started)

- Before disconnecting the connector, always turn the starting switch OFF.
- Before carrying out below procedure, check all the related connectors are properly inserted.
- After checking, insert the disconnected connectors again immediately unless otherwise specified.

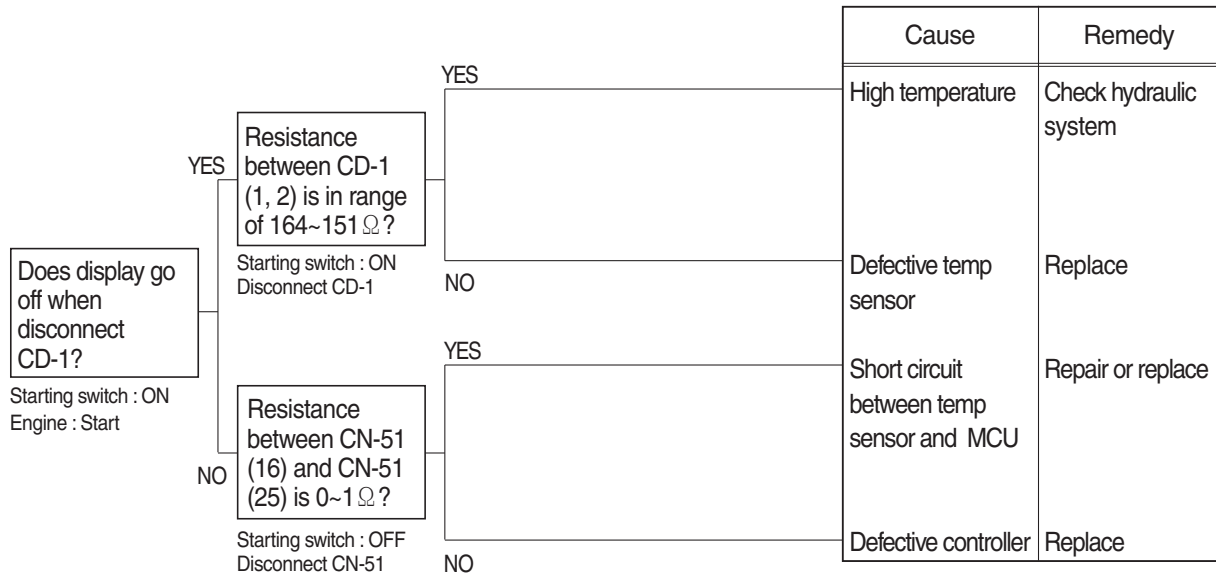

Check Table

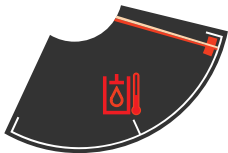

Temperature (°C)	~ -30	~ -10	~ 0	~ 40	~ 70	~ 80	~ 90	~ 100	105~
Resistance (kΩ)	22.22 ~31.78	8.16 ~10.74	5.18 ~ 6.6	1.06 ~1.28	0.39 ~0.476	0.322 ~0.298	0.243 ~0.219	0.185 ~0.167	0.164 0.151

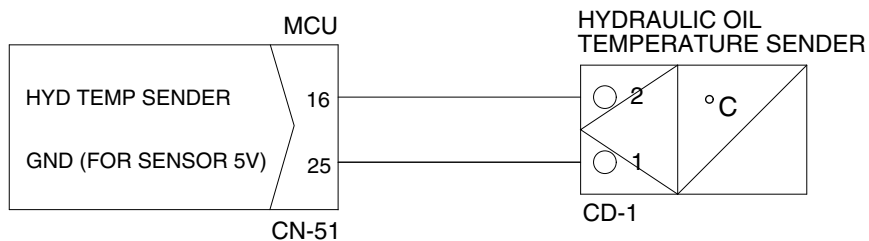

8. WHEN COOLANT TEMPERATURE GAUGE DOES NOT OPERATE (HCESPN 304, FMI 3 or 4)

- Before disconnecting the connector, always turn the starting switch OFF.
- Before carrying out below procedure, check all the related connectors are properly inserted.
- After checking, insert the disconnected connectors again immediately unless otherwise specified.

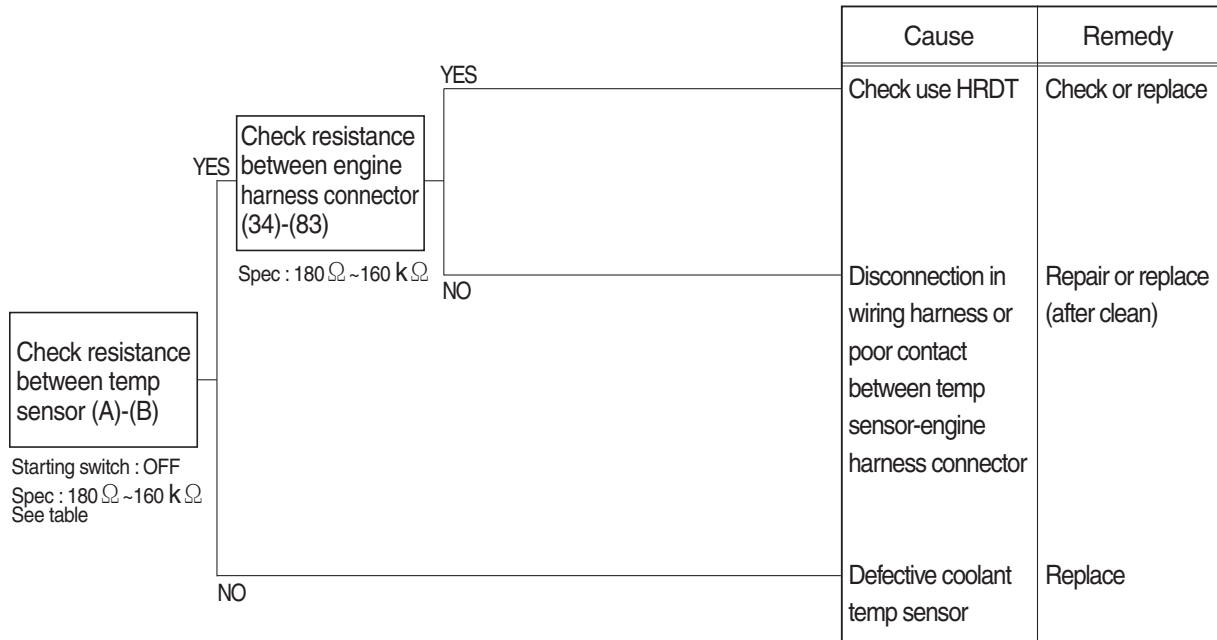

Check Table

Temperature (°C)	0	25	50	80	95
Resistance (kΩ)	30~37	9.3~10.7	3.2~3.8	1.0~1.3	0.7~0.8

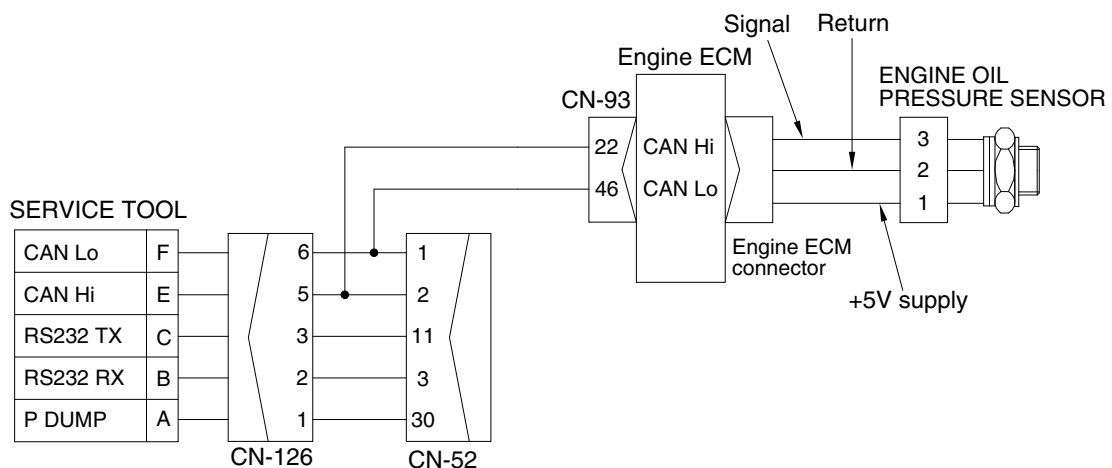

140WA6ES07

9. WHEN FUEL GAUGE DOES NOT OPERATE (HCESPN 301, FMI 3 or 4)

- Before disconnecting the connector, always turn the starting switch OFF.
- Before carrying out below procedure, check all the related connectors are properly inserted.
- After checking, insert the disconnected connectors again immediately unless otherwise specified.

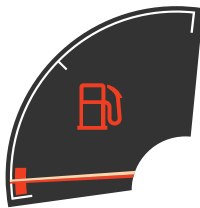
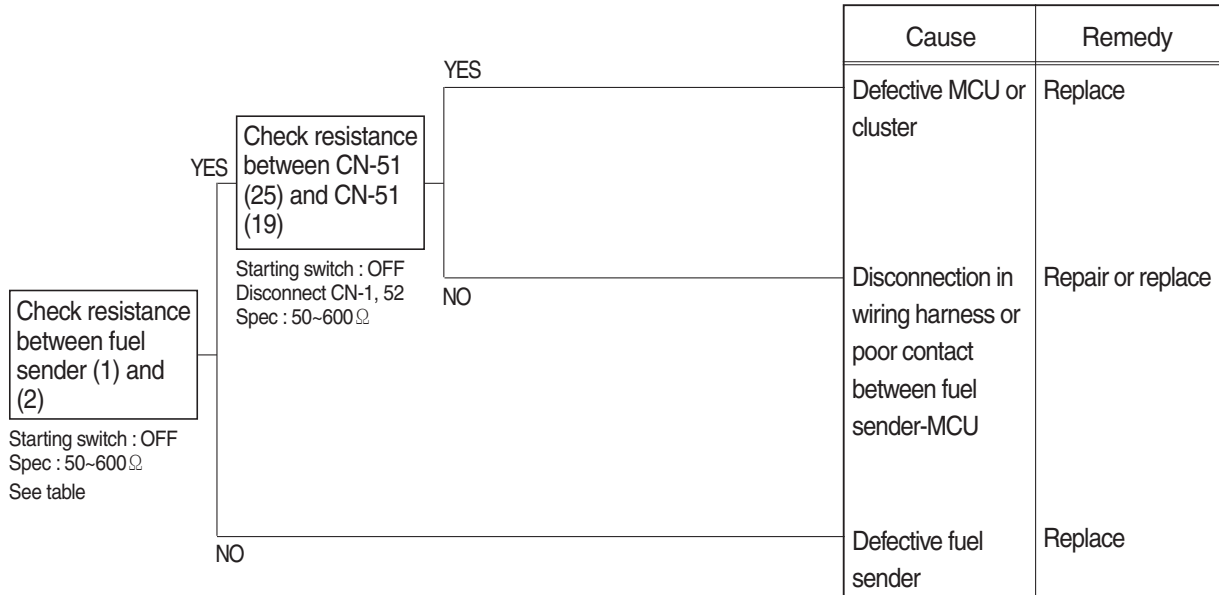

Check Table

Range	Resistance (Ω)	Range	Resistance (Ω)
Full	50	5/12	400
11/12	100	4/12	450
10/12	150	3/12	500
9/12	200	2/12	550
8/12	250	1/12	600
7/12	300	Empty warning	700
6/12	350	-	-

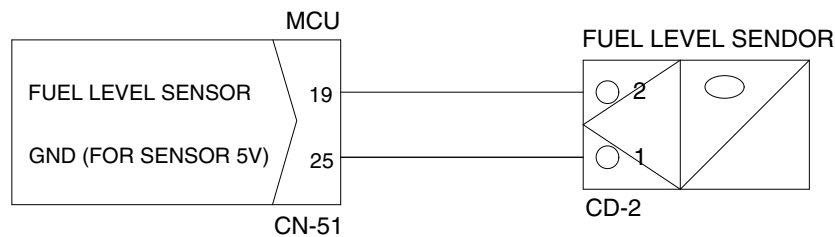

10. WHEN SAFETY SOLENOID DOES NOT OPERATE

- Before disconnecting the connector, always turn the starting switch OFF.
- Before carrying out below procedure, check all the related connectors are properly inserted and short of fuse No. 28.
- After checking, insert the disconnected connectors again immediately unless otherwise specified.

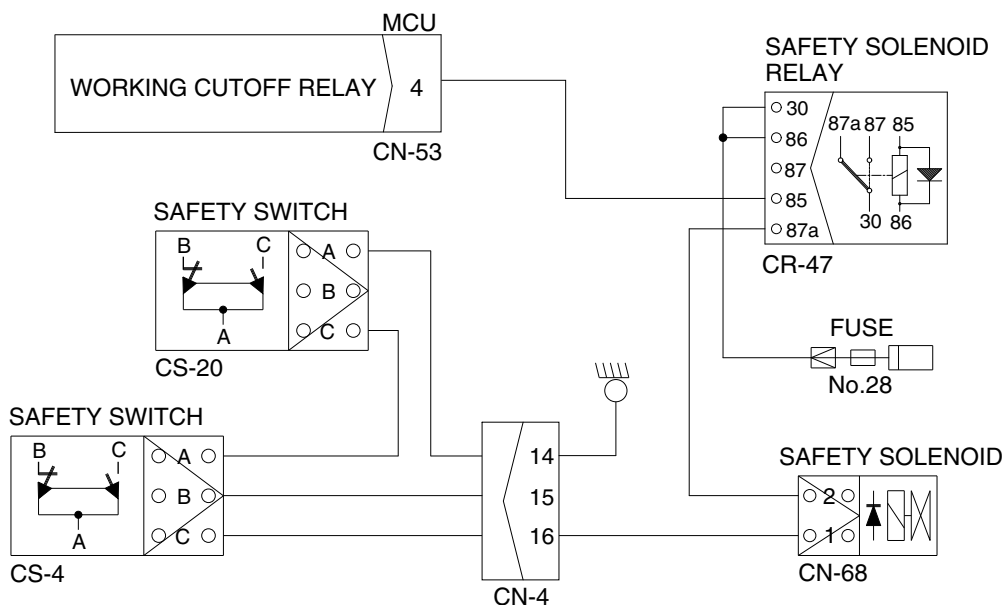
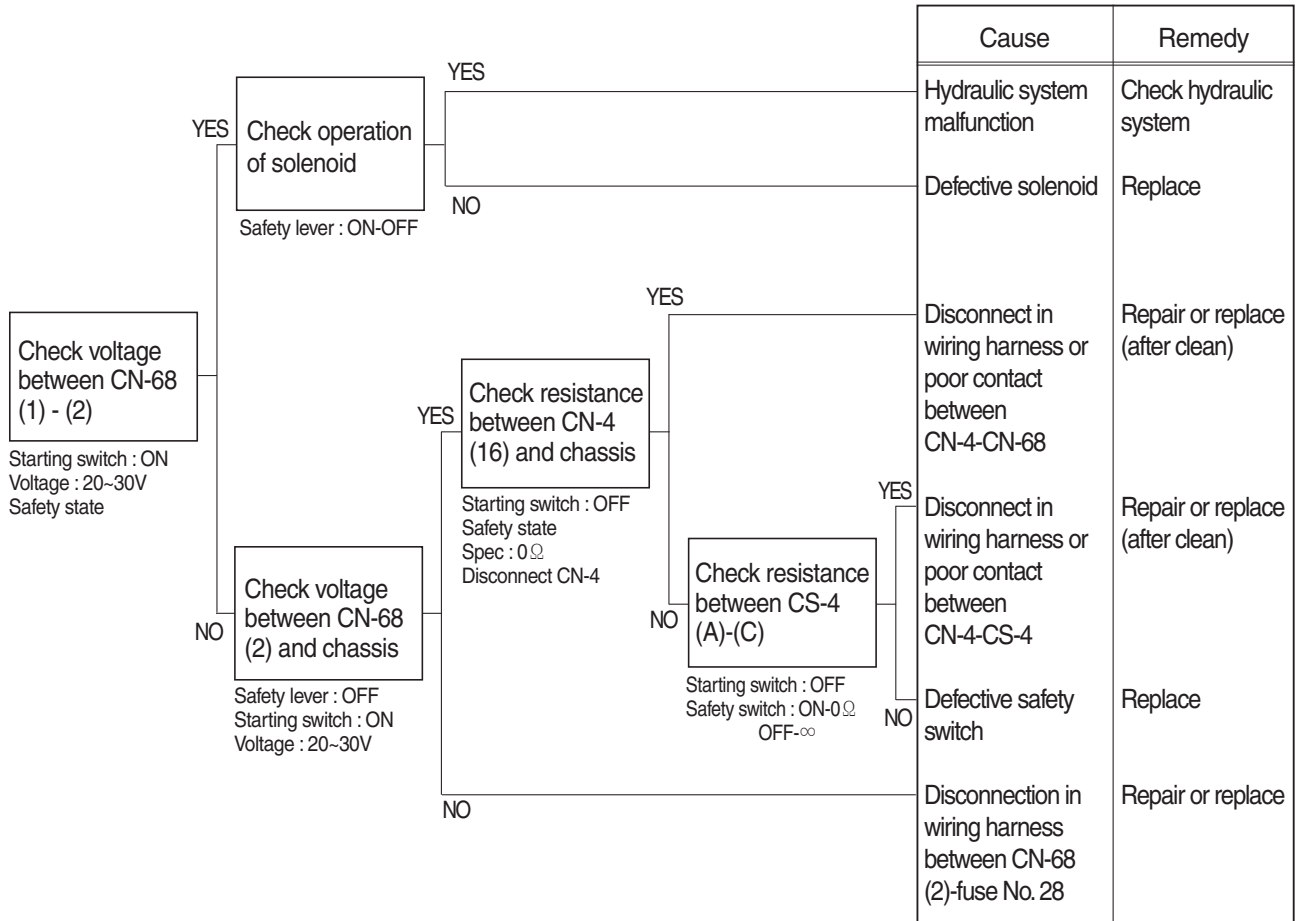

140WA6ES12

11. WHEN TRAVEL SPEED 1, 2 DOES NOT OPERATE (HCESPN 167, FMI 4 or 6)

- Before disconnecting the connector, always turn the starting switch OFF.
- Before carrying out below procedure, check all the related connectors are properly inserted and short of fuse No. 30.
- After checking, insert the disconnected connectors again immediately unless otherwise specified.

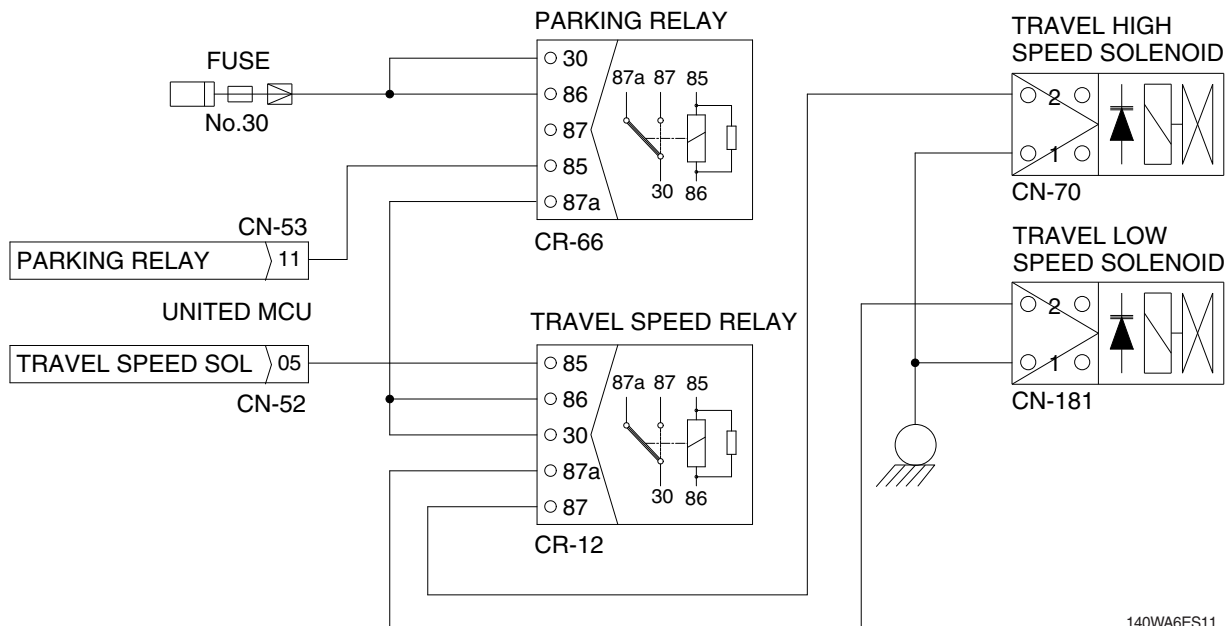
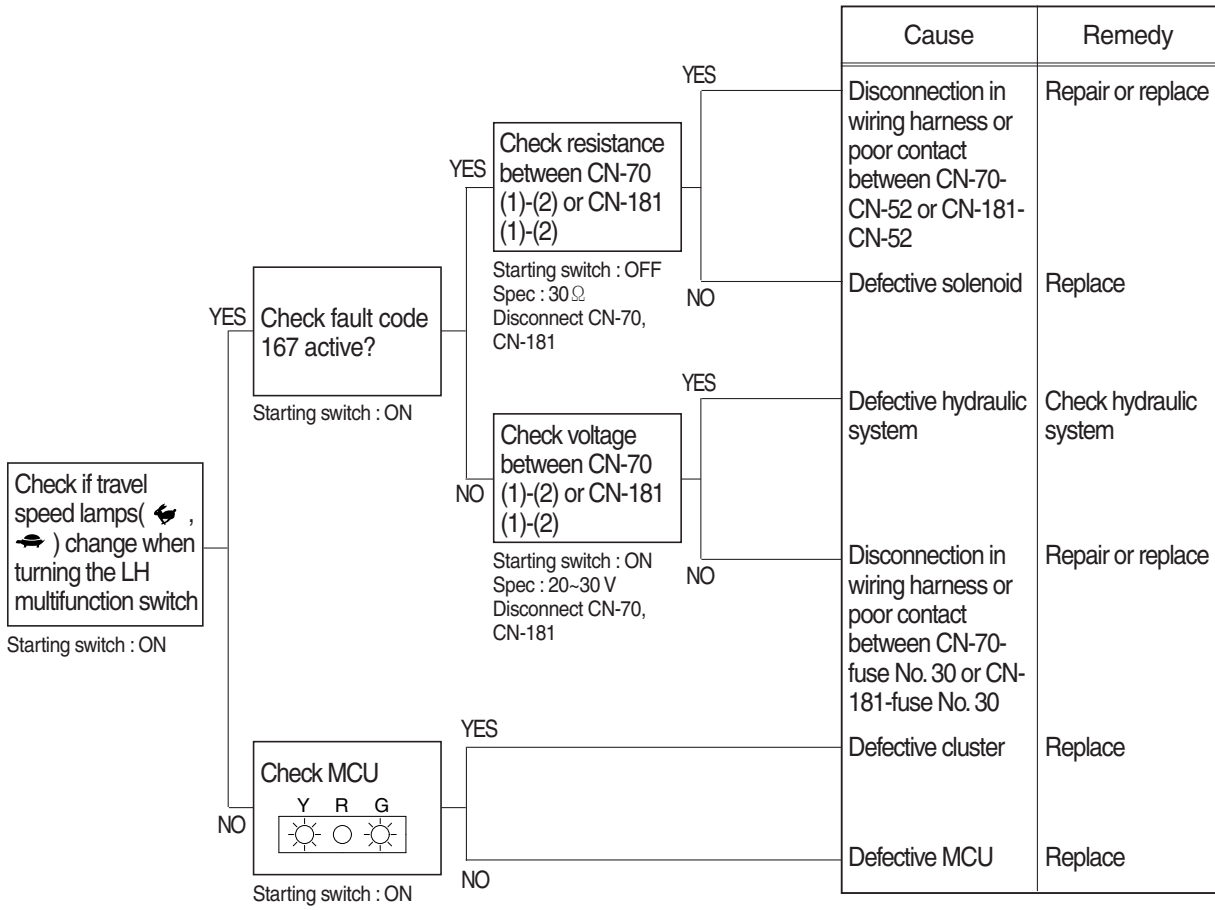

140WA6ES11

12. WHEN ENGINE DOES NOT START (lights up condition)

- Before disconnecting the connector, always turn the starting switch OFF.
- Before carrying out below procedure, check all the related connectors are properly inserted and short of fuse No. 4, 9, 14, 15, 25, 26, 38.
- After checking, insert the disconnected connectors again immediately unless otherwise specified.

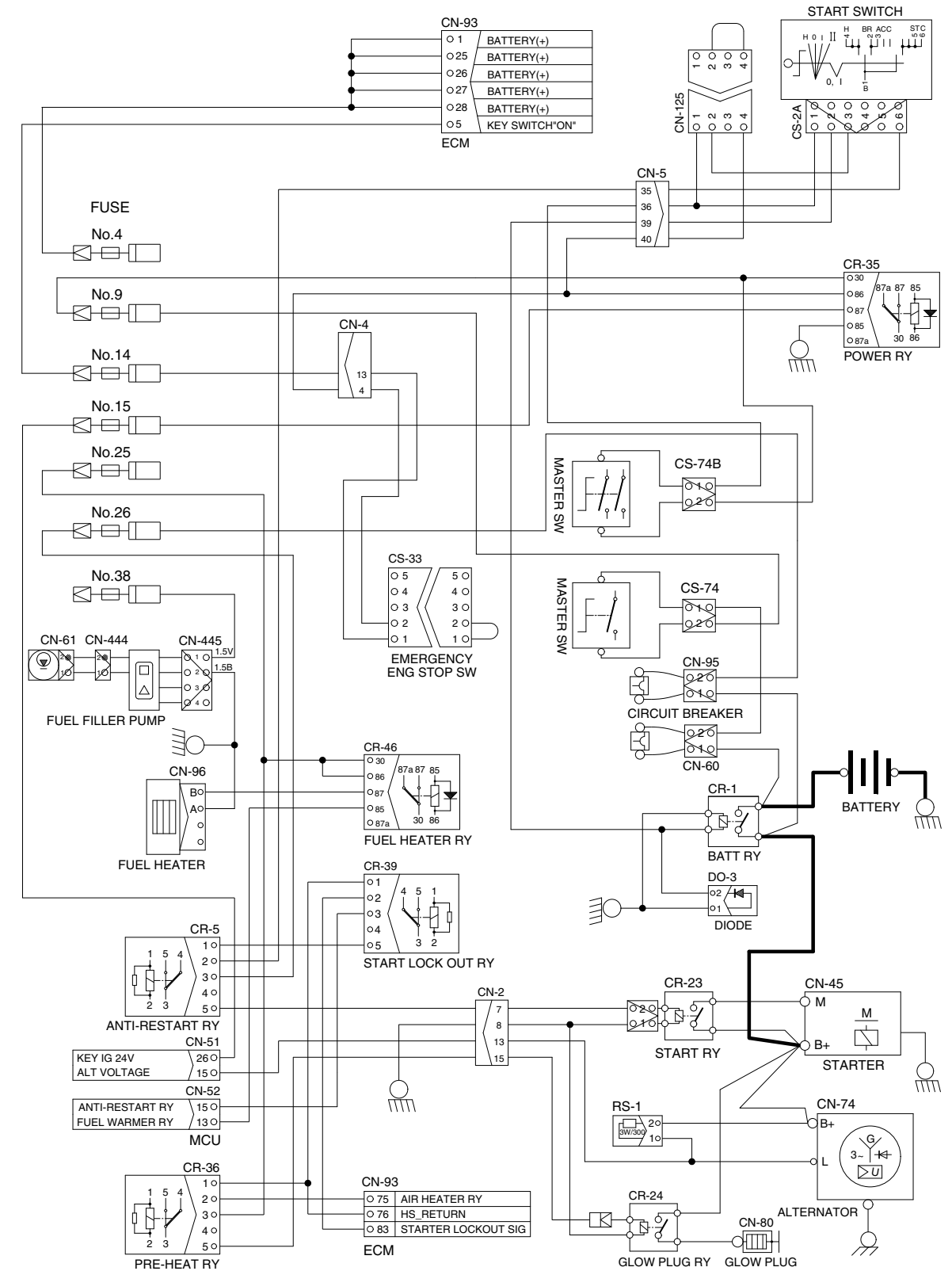
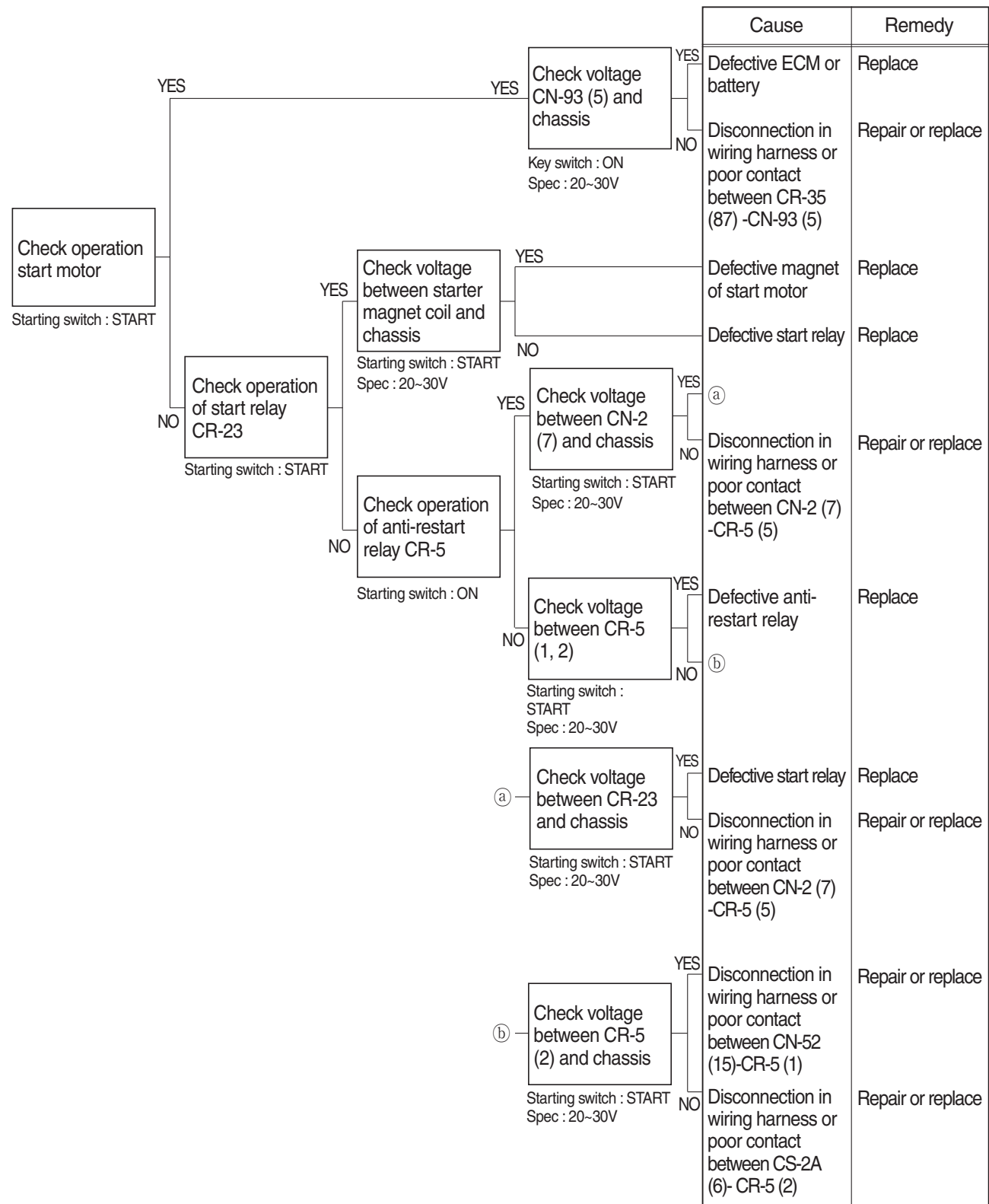

13. WHEN STARTING SWITCH ON DOES NOT OPERATE

- Before disconnecting the connector, always turn the starting switch OFF.
- Before carrying out below procedure, check all the related connectors are properly inserted, master switch ON and check open circuit of circuit breaker (CN-60, CN-95).
- After checking, insert the disconnected connectors again immediately unless otherwise specified.

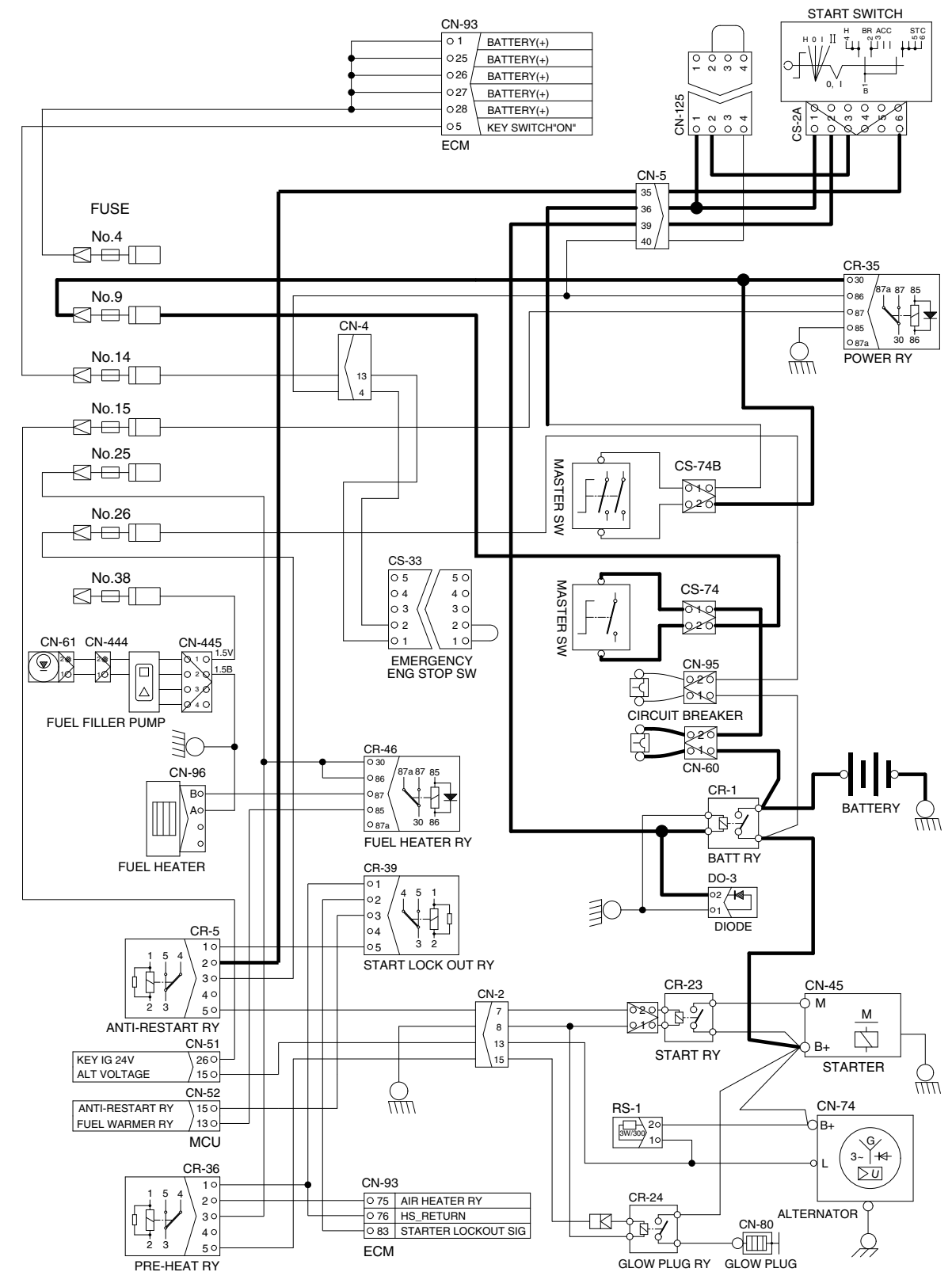
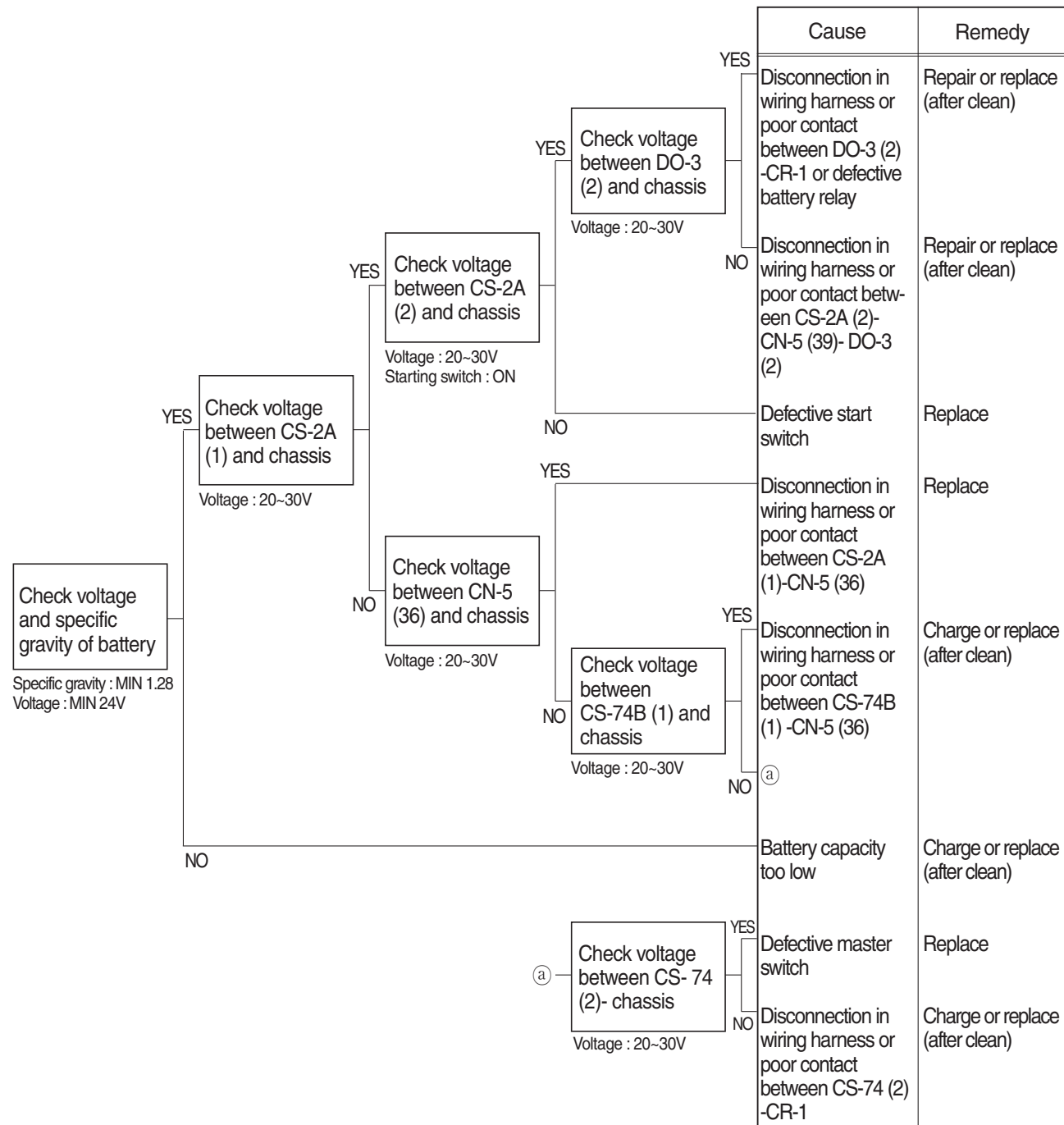

14. WHEN STARTING SWITCH IS TURNED ON, WIPER MOTOR DOES NOT OPERATE

- Before disconnecting the connector, always turn the starting switch OFF.
- Before carrying out below procedure, check all the related connectors are properly inserted and the fuse No. 11, 24 and 40 is not blown out.
- After checking, insert the disconnected connectors again immediately unless otherwise specified.

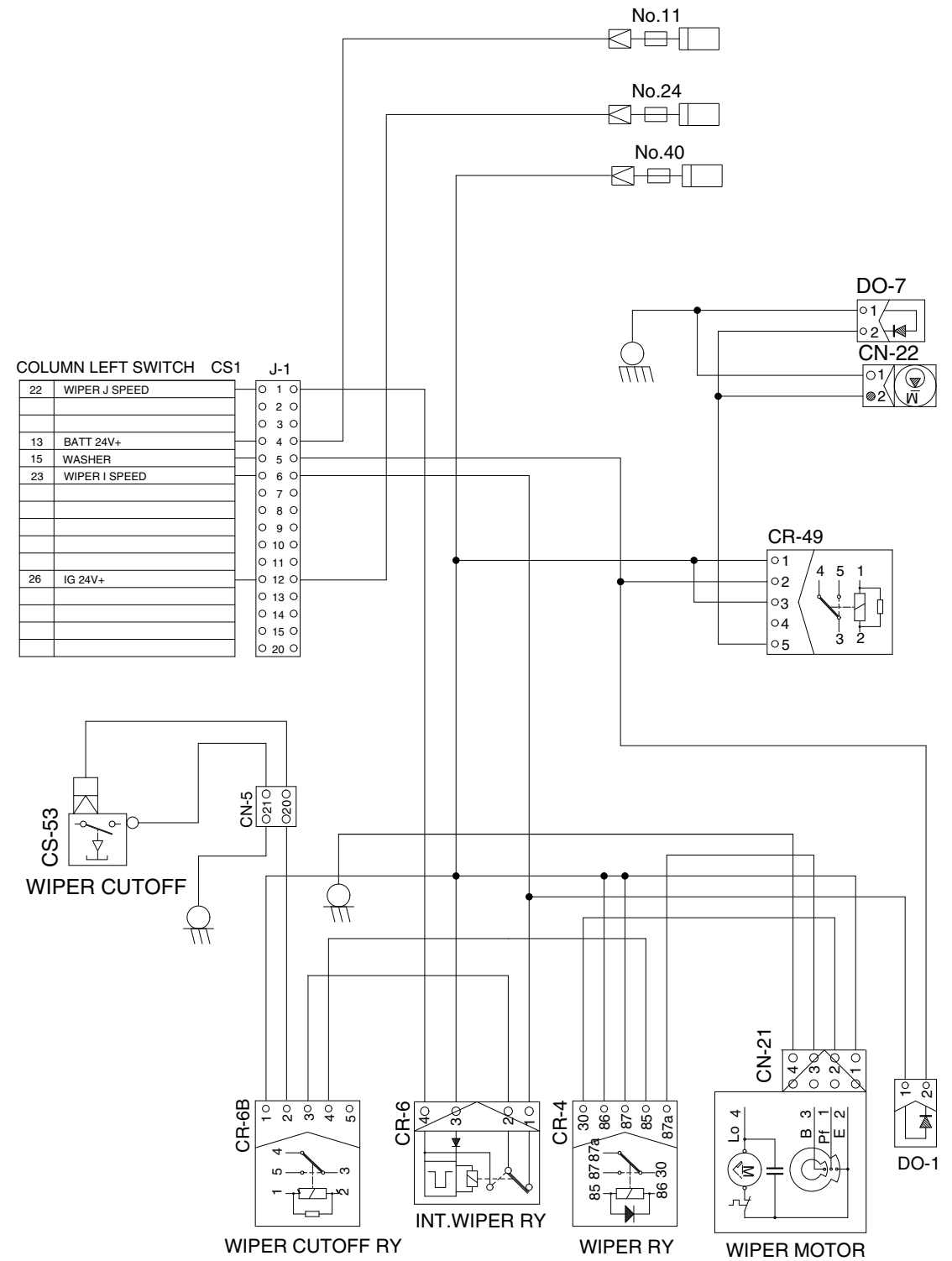
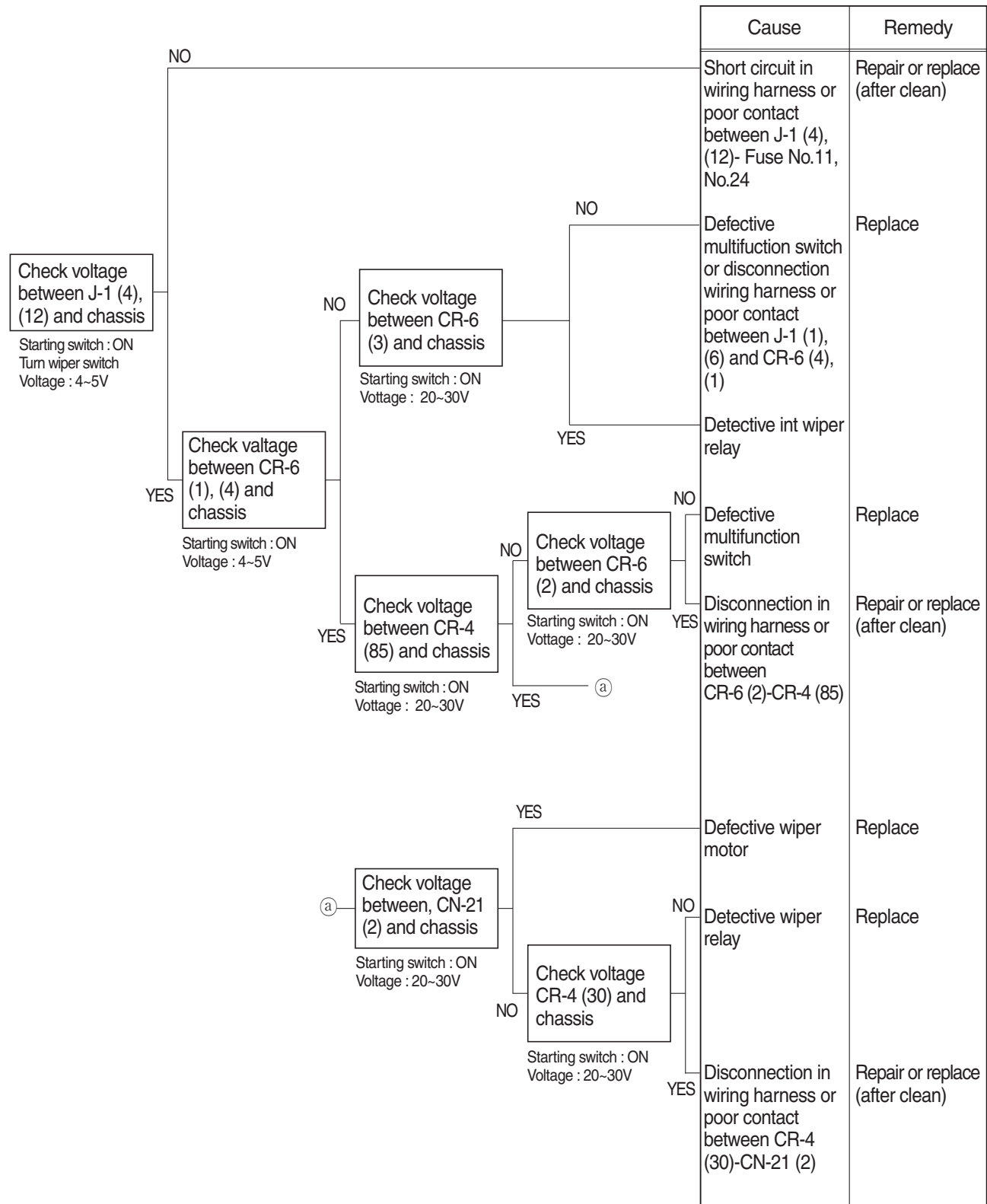

15. WHEN STARTING SWITCH IS TURNED ON, HEAD LAMP DOES NOT LIGHTS UP

- Before disconnecting the connector, always turn the starting switch OFF.
- Before carrying out below procedure, check all the related connectors are properly inserted and short of fuse No. 11, 17, 23.
- After checking, insert the disconnected connectors again immediately unless otherwise specified.

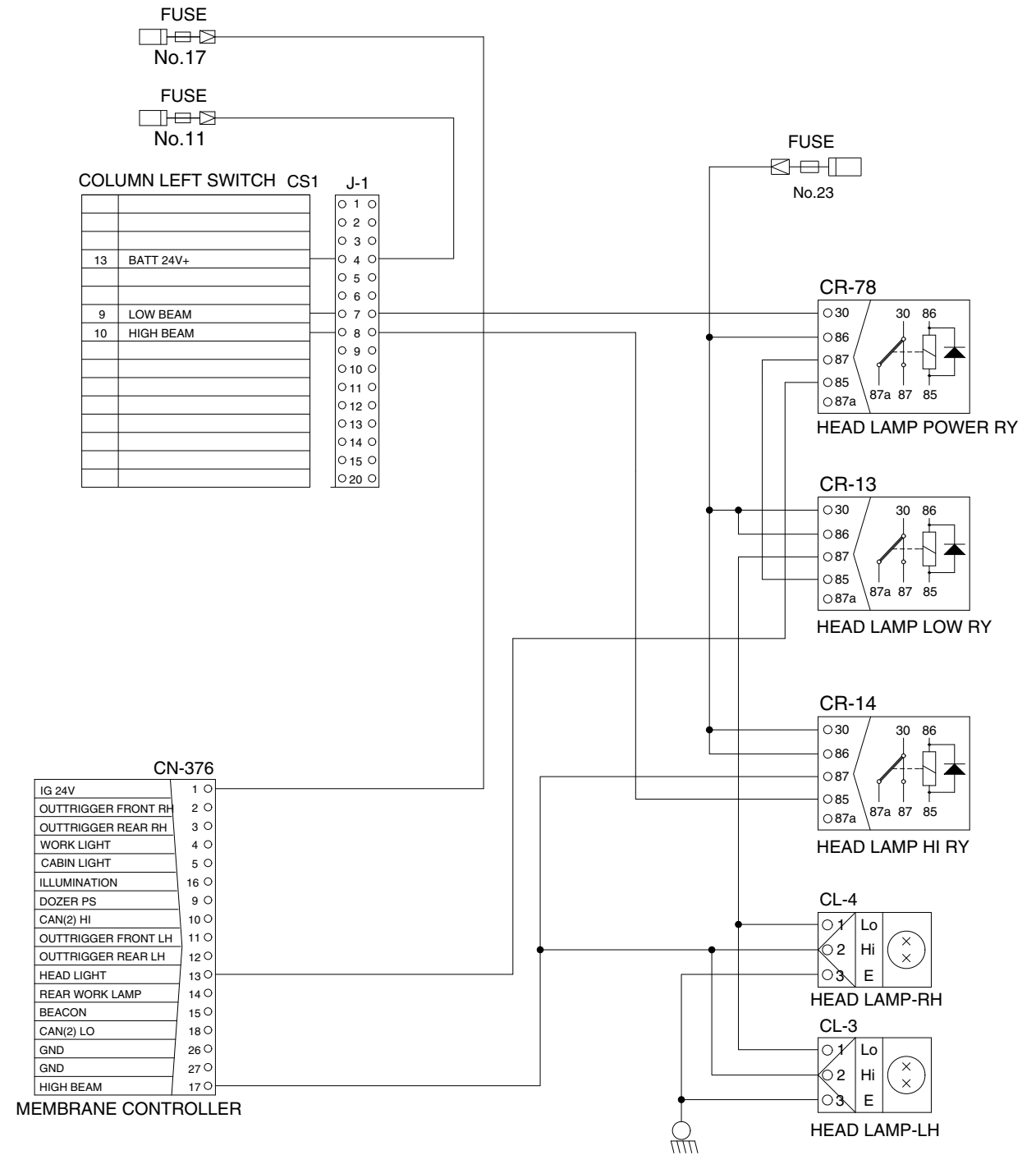
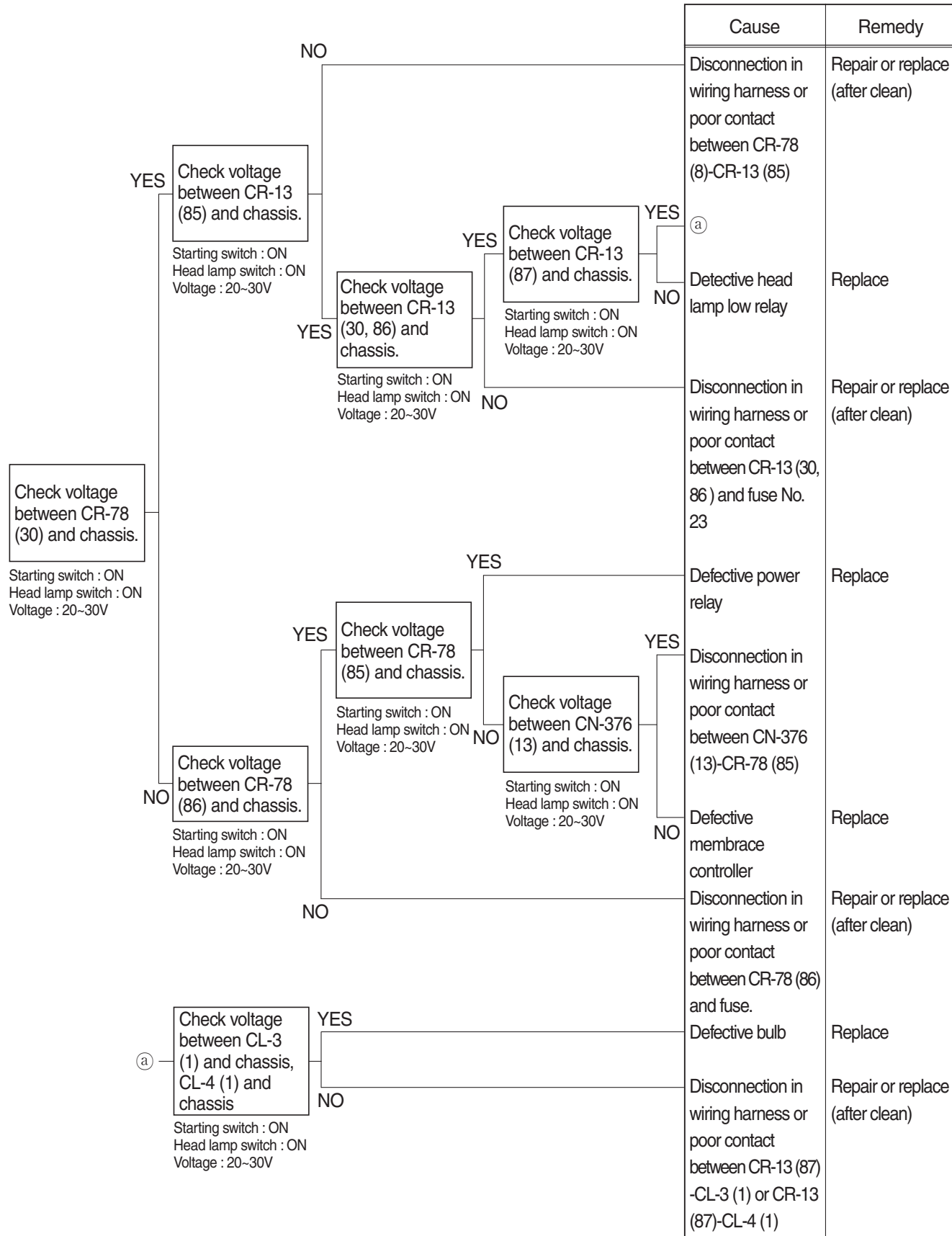

16. WHEN STARTING SWITCH IS TURNED ON, WORK LAMP DOES NOT LIGHTS UP

- Before disconnecting the connector, always turn the starting switch OFF.
- Before carrying out below procedure, check all the related connectors are properly inserted and short of fuse No. 17, 21.
- After checking, insert the disconnected connectors again immediately unless otherwise specified.

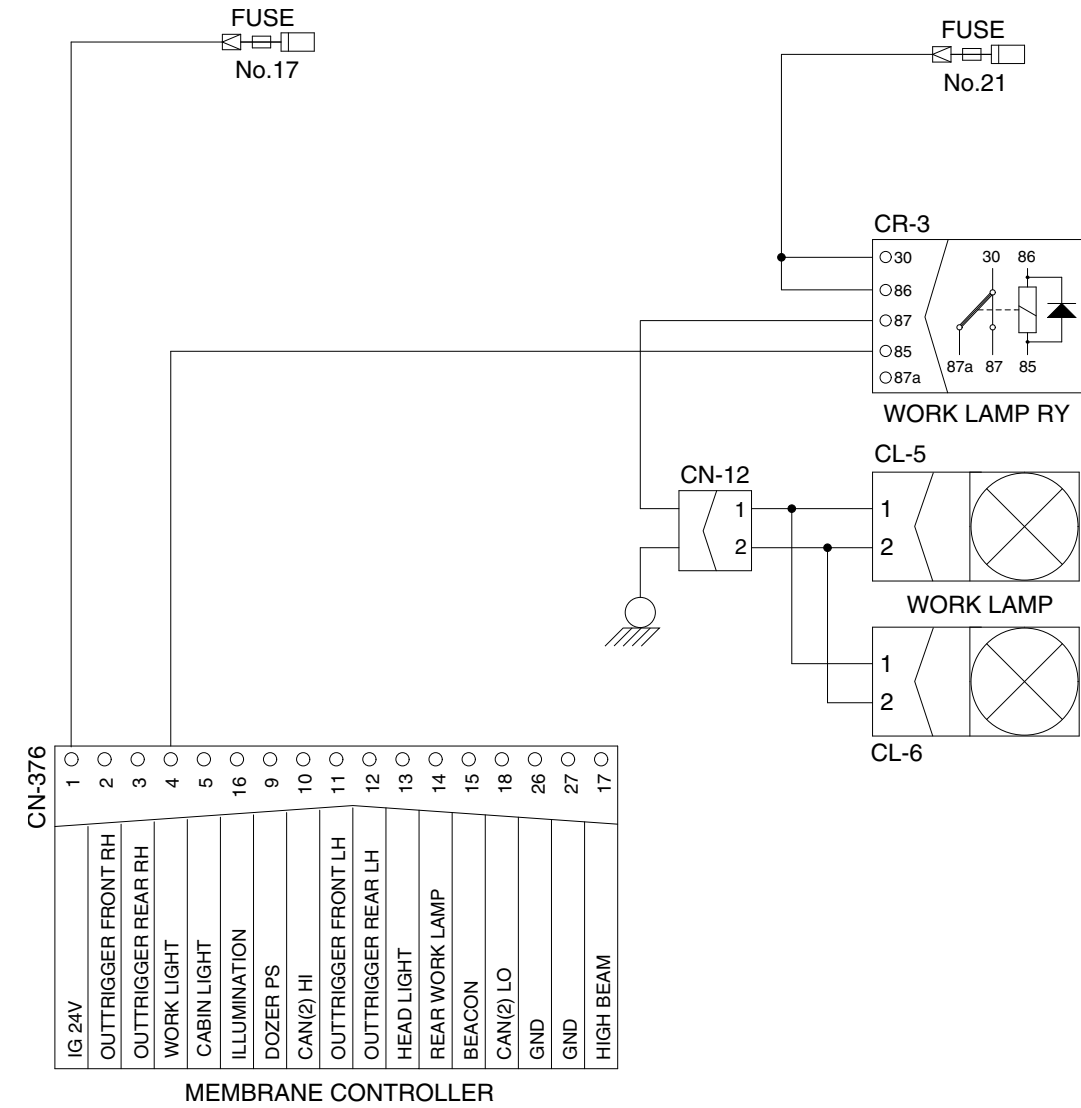
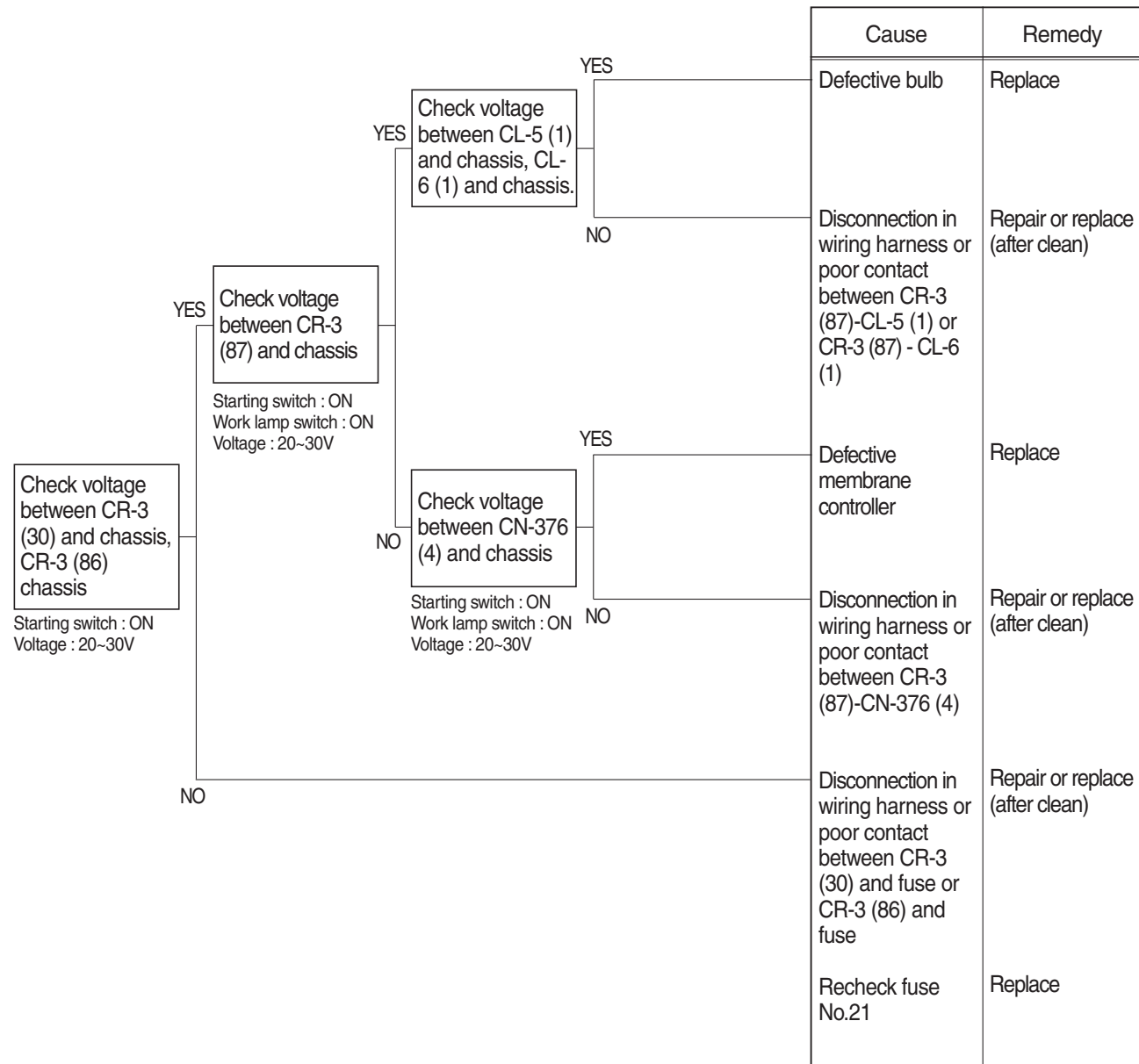

GROUP 4 MECHATRONICS SYSTEM

1. ALL ACTUATORS SPEED ARE SLOW

- ※ Boom, Arm, Bucket, Swing and travel speed are slow, but engine speed is good.
- ※ Spec : P-mode 1600 ± 50 rpm S-mode 1500 ± 50 rpm E-mode 1450 ± 50 rpm
- ※ Before carrying out below procedure, check all the related connectors are properly inserted and fault code on the cluster.

1) INSPECTION PROCEDURE

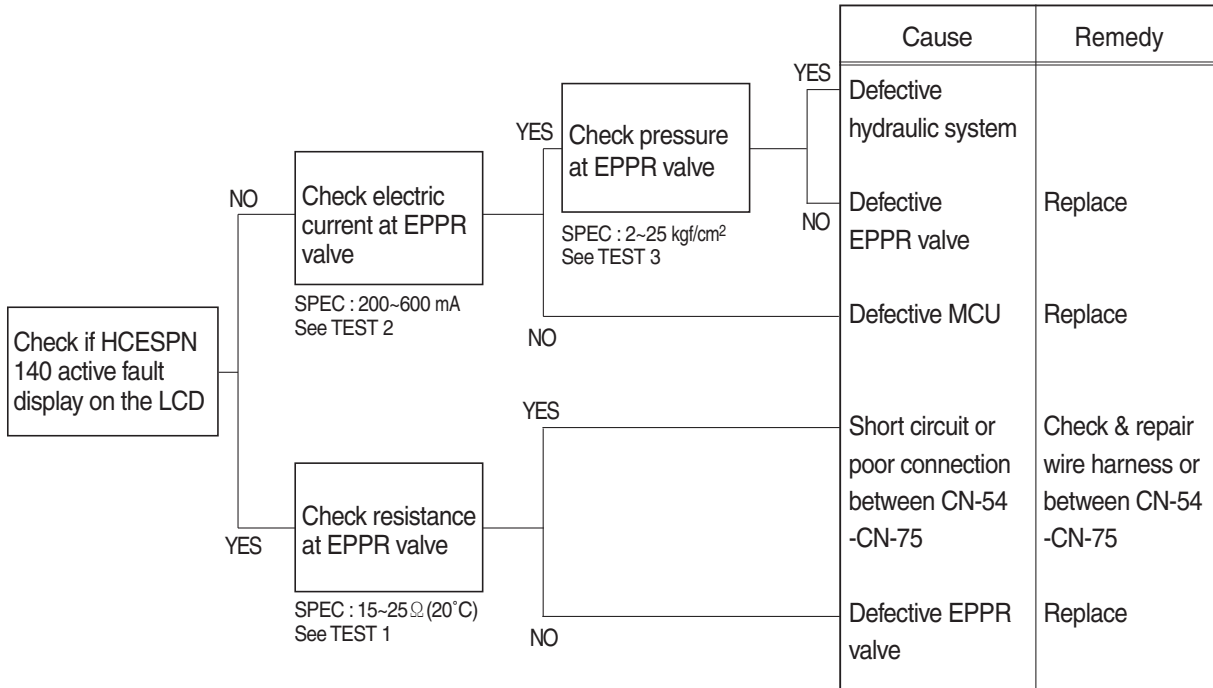

Wiring diagram

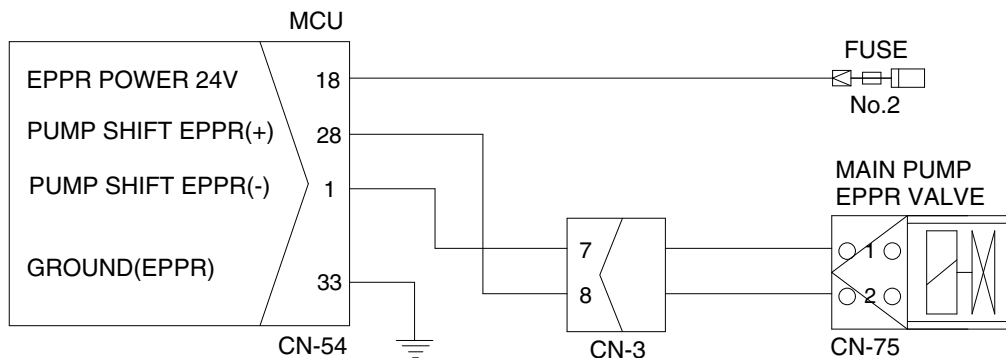

140WA6MS01

2) TEST PROCEDURE

(1) **Test 1** : Check resistance at connector CN-75.

- ① Starting switch OFF.
- ② Disconnect connector CN-75 from EPPR valve at main hydraulic pump.
- ③ Check resistance between 2 lines as figure.

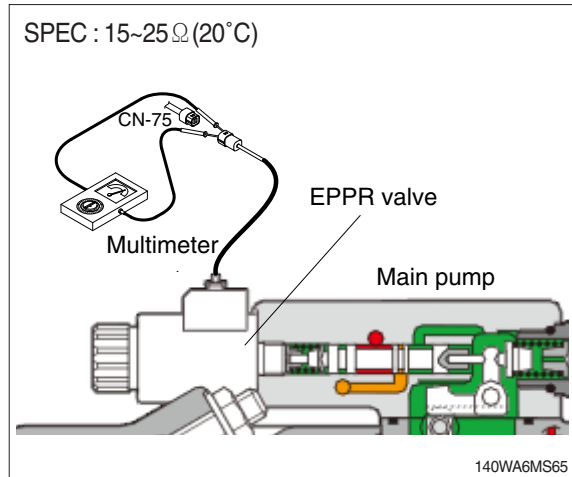

(2) **Test 2** : Check electric current at EPPR valve.

- ① Disconnect connector CN-75 from EPPR valve.
- ② Insert the adapter to CN-75 and install multimeter as figure.
- ③ Start engine.
- ④ Set S-mode and cancel auto decel mode.
- ⑤ Position the multimodal dial at 10.
- ⑥ If tachometer show approx 1500 ± 50 rpm disconnect one wire harness from EPPR valve.
- ⑦ Check electric current at bucket circuit relief position.

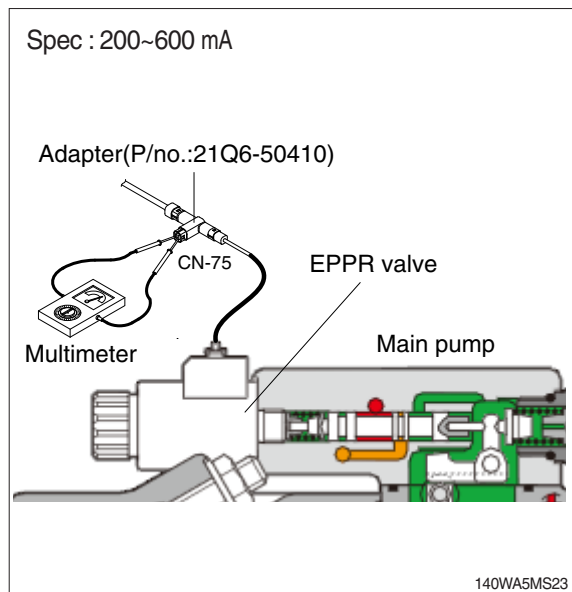

(3) **Test 3** : Check pressure at EPPR valve.

- ① Remove plug and connect pressure gauge as figure.
 - Gauge capacity : 0 to 50 kgf/cm²
(0 to 725 psi)
- ② Start engine.
- ③ Set S-mode and cancel auto decel mode.
- ④ Position the multimodal dial at 10.
- ⑤ If tachometer show approx 1500 ± 50 rpm check pressure at relief position of bucket circuit by operating bucket control lever.
- ⑥ If pressure is not correct, adjust it.
- ⑦ After adjust, test the machine.

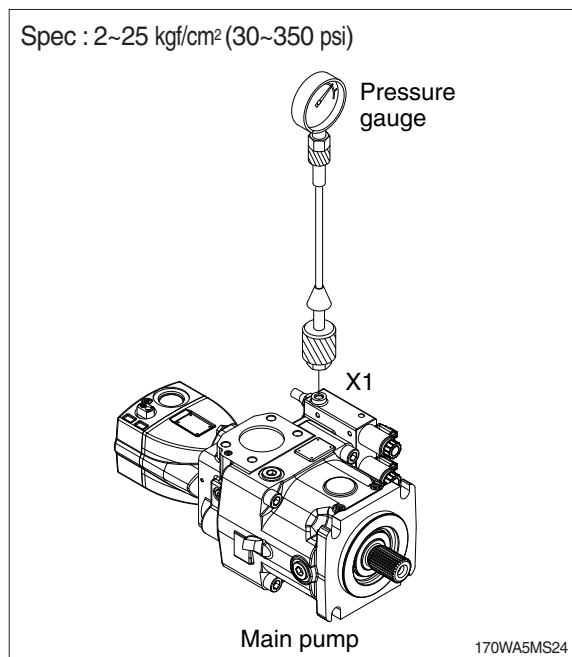

2. ENGINE STALL

※ Before carrying out below procedure, check all the related connectors are properly inserted.

1) INSPECTION PROCEDURE

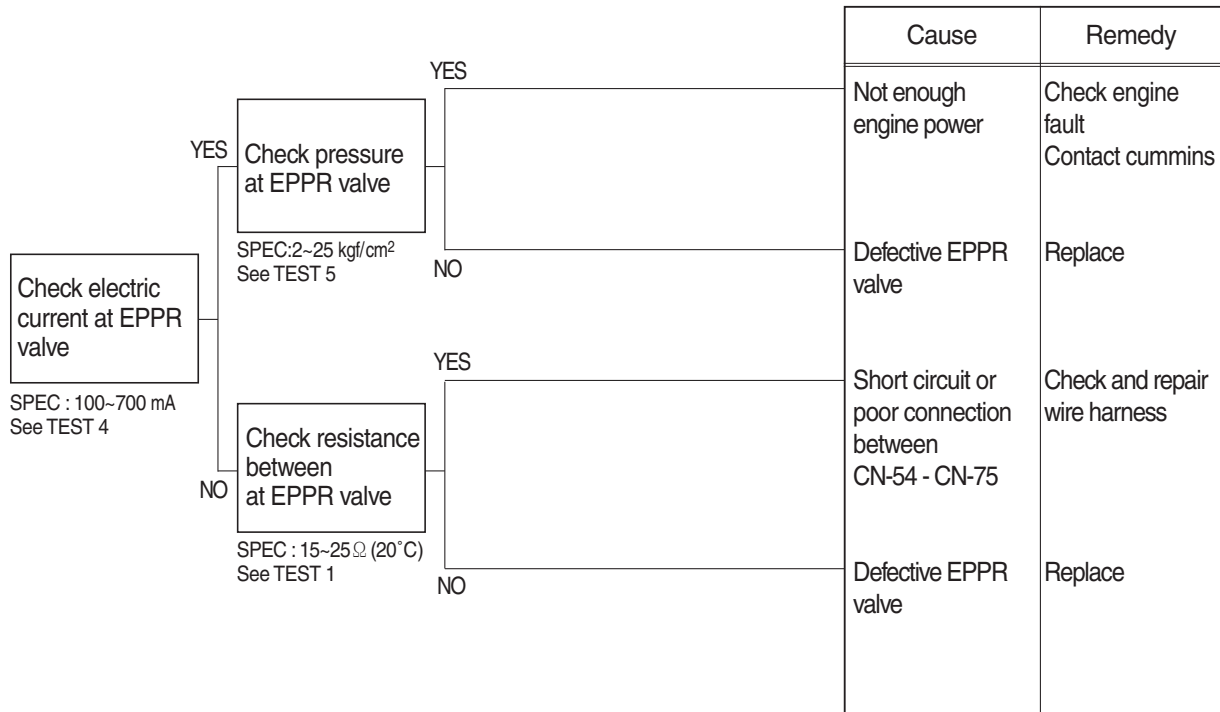

Wiring diagram

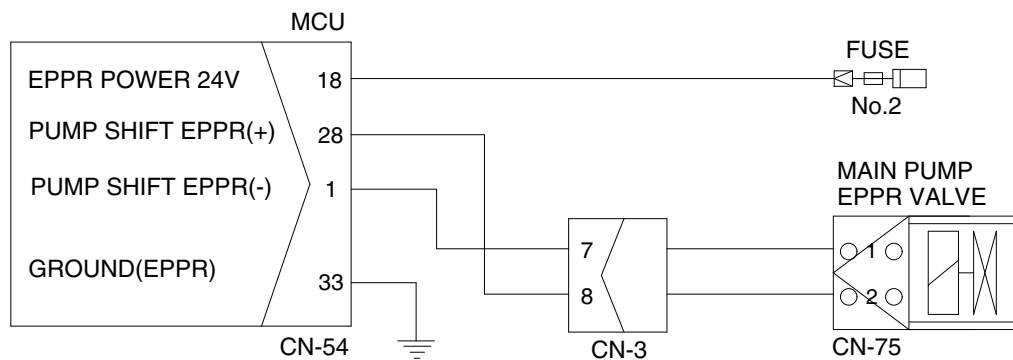

140WA6MS01

2) TEST PROCEDURE

(1) Test 4 : Check electric current at EPPR valve.

- ① Disconnect connector CN-75 from EPPR valve.
- ② Insert the adapter to CN-75 and install multimeter as figure.
- ③ Start engine.
- ④ Set S-mode and cancel auto decel mode.
- ⑤ Position the multimodal dial at 10.
- ⑥ If rpm show approx 1500 ± 50 rpm disconnect one wire harness from EPPR valve.
- ⑦ Check electric current at bucket circuit relief position.

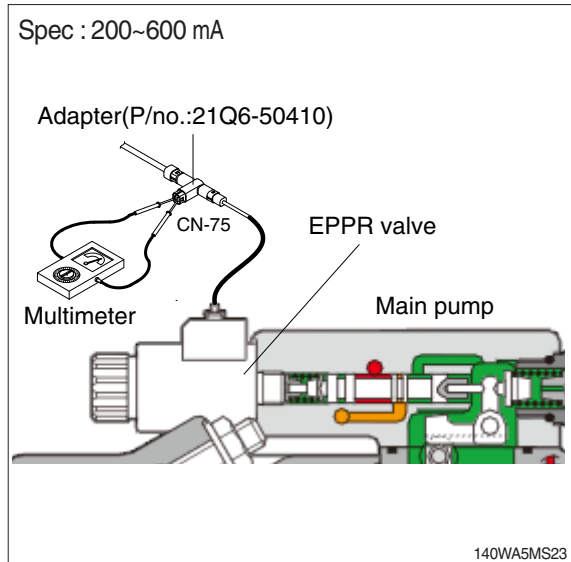

(2) Test 5 : Check pressure at EPPR valve.

- ① Remove plug and connect pressure gauge as figure.
 - Gauge capacity : 0 to 50 kgf/cm²
(0 to 725 psi)
- ② Start engine.
- ③ Set S-mode and cancel auto decel mode.
- ④ Position the multimodal dial at 10.
- ⑤ If rpm show approx 1500 ± 50 rpm check pressure at relief position of bucket circuit by operating bucket control lever.
- ⑥ If pressure is not correct, adjust it.
- ⑦ After adjust, test the machine.

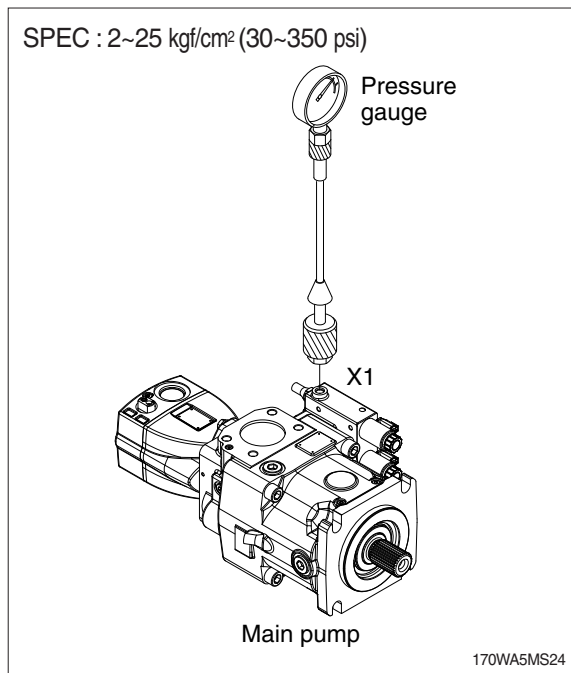

3. MALFUNCTION OF CLUSTER OR MODE SELECTION SYSTEM

※ Before carrying out below procedure, check all the related connectors are properly inserted.

1) INSPECTION PROCEDURE

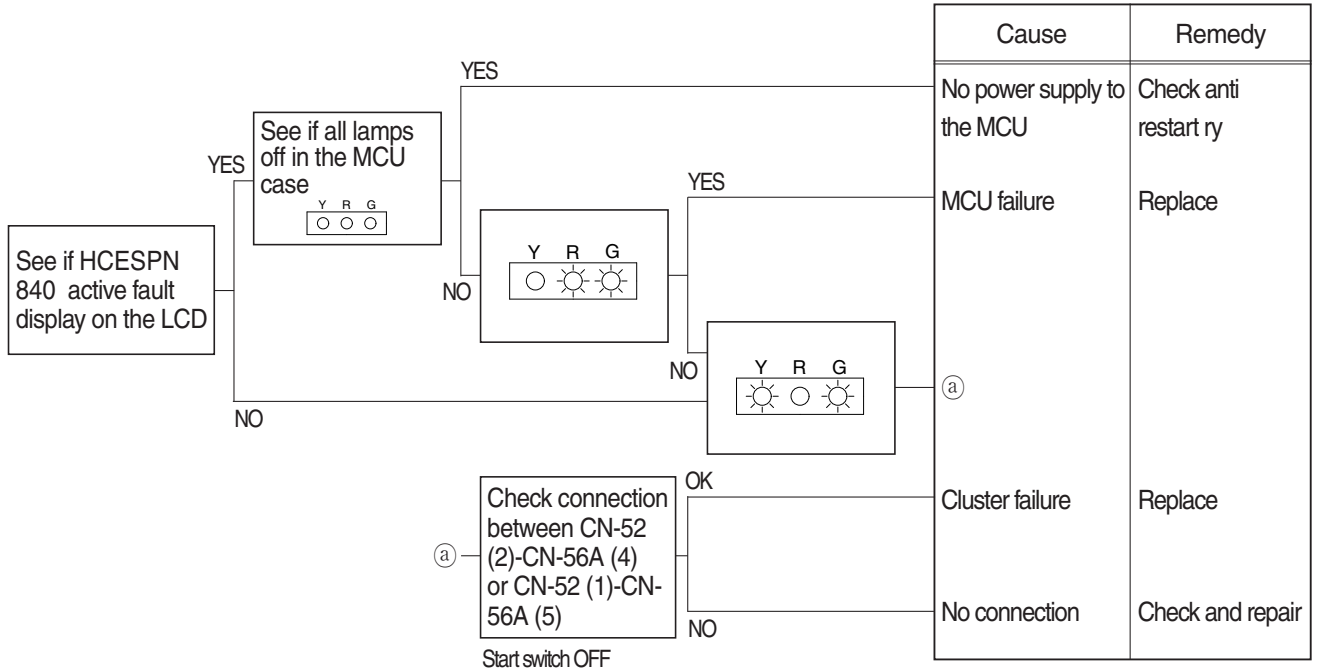

Wiring diagram

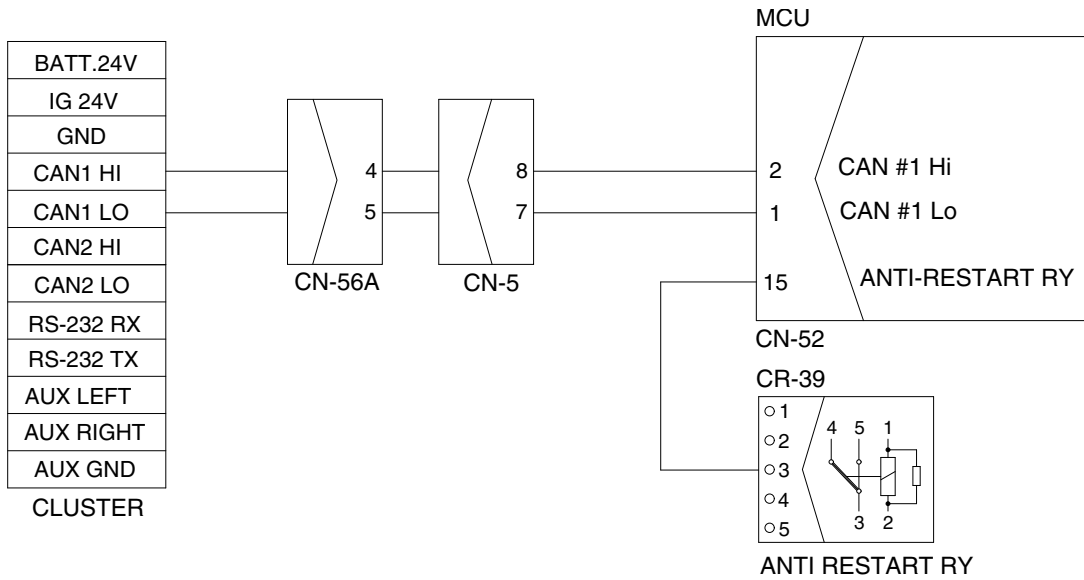

140WA6MS02

4. AUTO DECEL SYSTEM DOES NOT WORK

- Fault code : HCESPN 105, FMI 0~4 (work pressure sensor)
HCESPN 108, FMI 0~4 (travel oil pressure sensor)

※ Before carrying out below procedure, check all the related connectors are properly inserted.

1) INSPECTION PROCEDURE

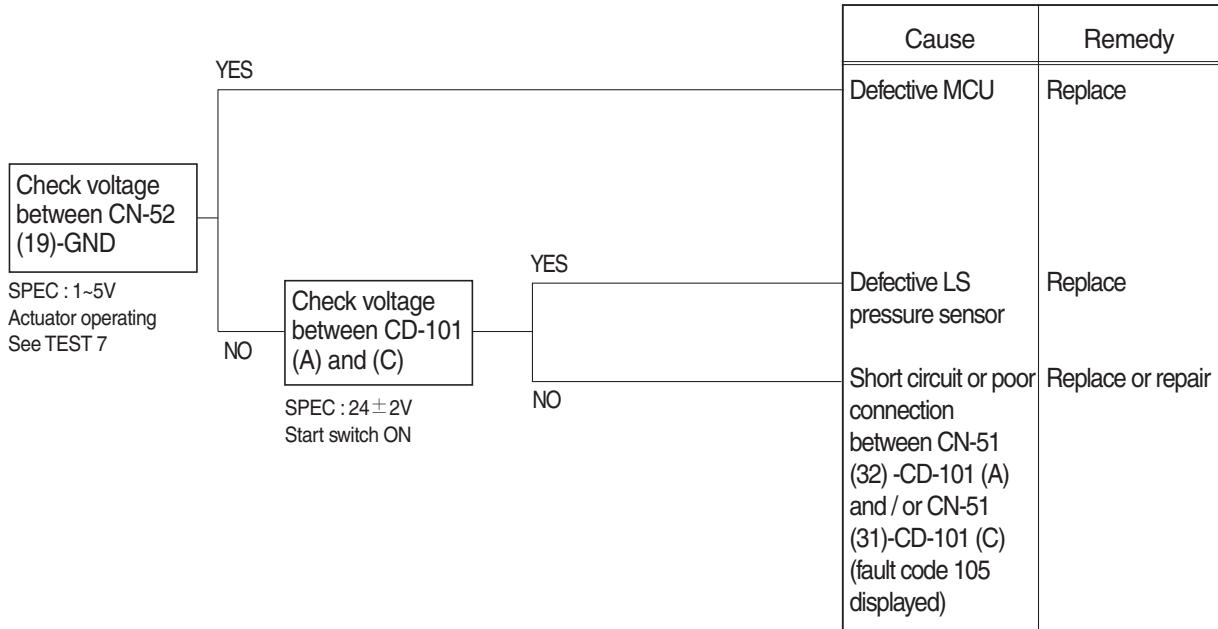

Wiring diagram

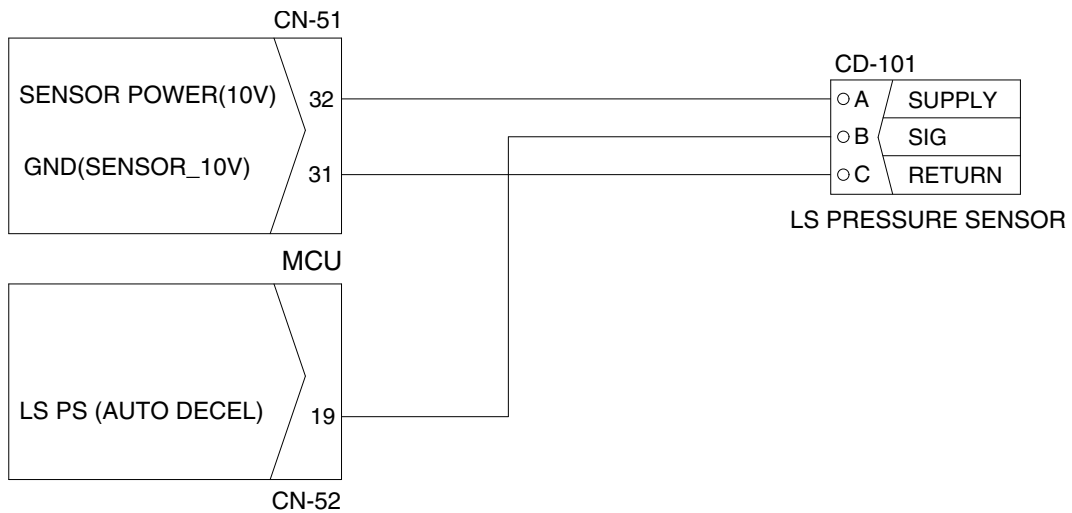

2) TEST PROCEDURE

(1) **Test 7** : Check voltage at CN-52 (19) and ground.

- ① Prepare 1 piece of thin sharp pin, steel or copper.
- ② Insert prepared pin to rear side of connectors : One pin to (19) of CN-52.
- ③ Starting switch ON.
- ④ Check voltage as figure.

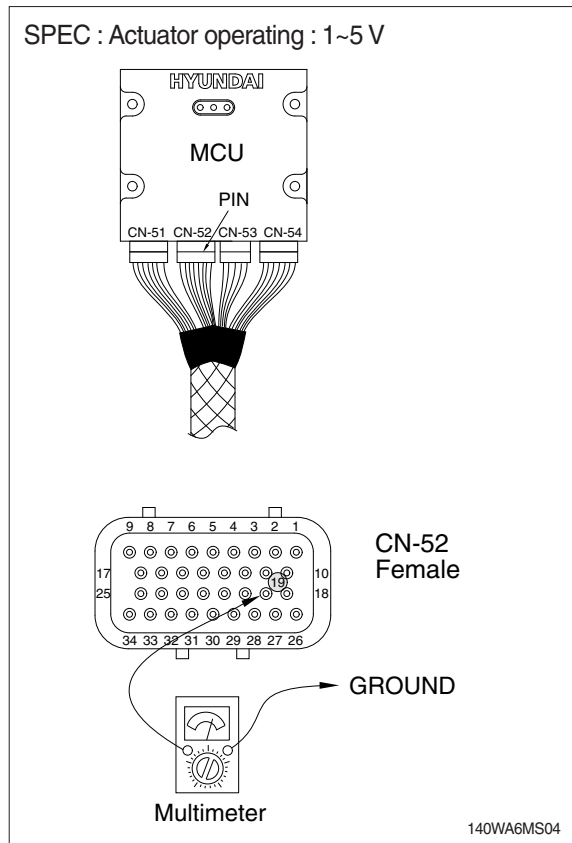

5. MALFUNCTION OF PUMP (A) PRESSURE SENSOR

· Fault code : HCESPN 120, FMI 0~4

※ Before carrying out below procedure, check all the related connectors are properly inserted.

1) INSPECTION PROCEDURE

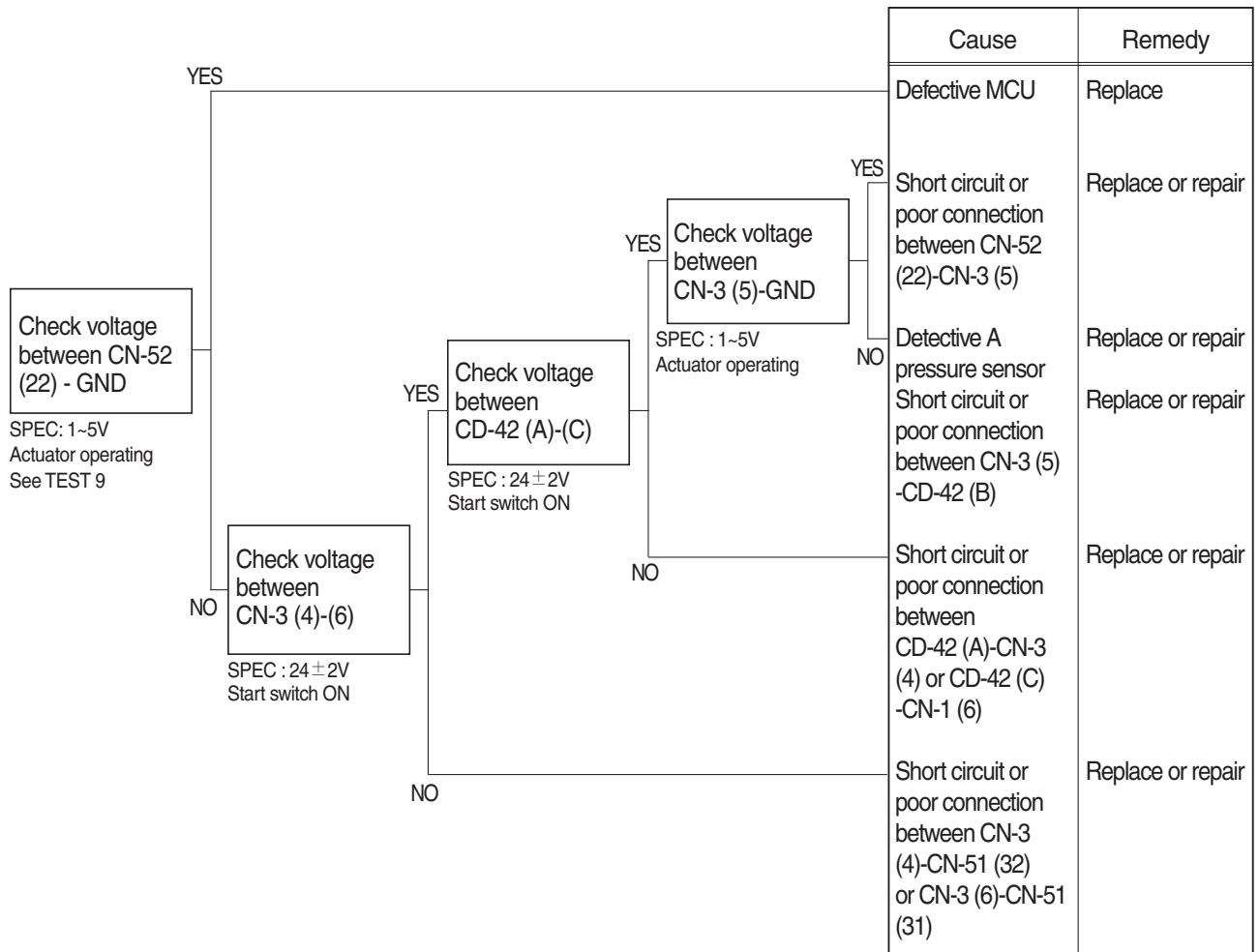

Wiring diagram

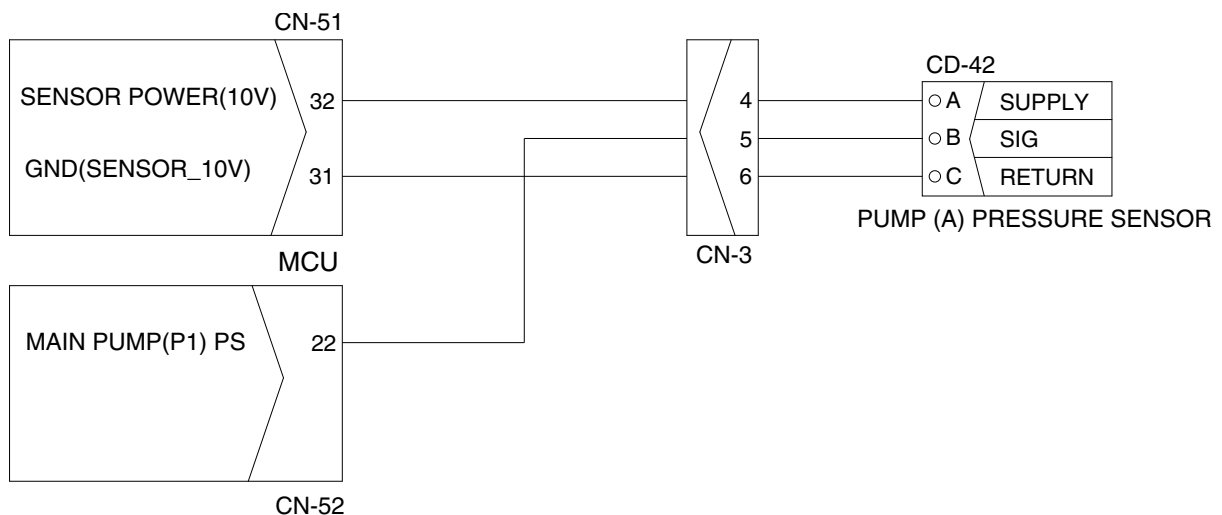

140WA6MS05

2) TEST PROCEDURE

(1) **Test 9** : Check voltage at CN-52 (22) and ground.

- ① Prepare 1 piece of thin sharp pin, steel or copper.
- ② Insert prepared pin to rear side of connectors : One pin to (22) of CN-52.
- ③ Starting switch ON.
- ④ Check voltage as figure.

SPEC : Actuator operating : 1~5 V

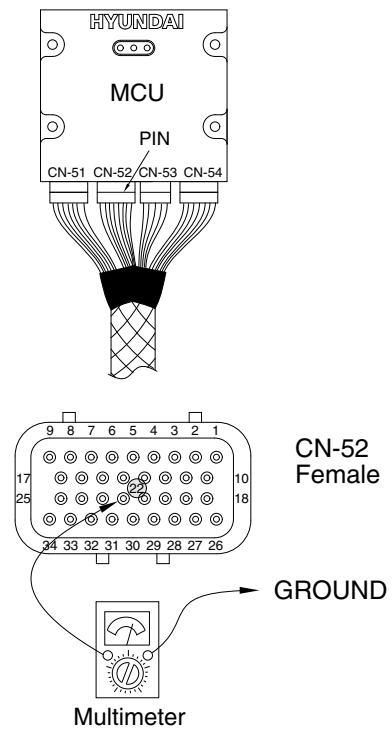

140WF6MS106

6. MALFUNCTION OF PUMP (B) PRESSURE SENSOR

· Fault code : HCESPN 121, FMI 0~4

※ Before carrying out below procedure, check all the related connectors are properly inserted.

1) INSPECTION PROCEDURE

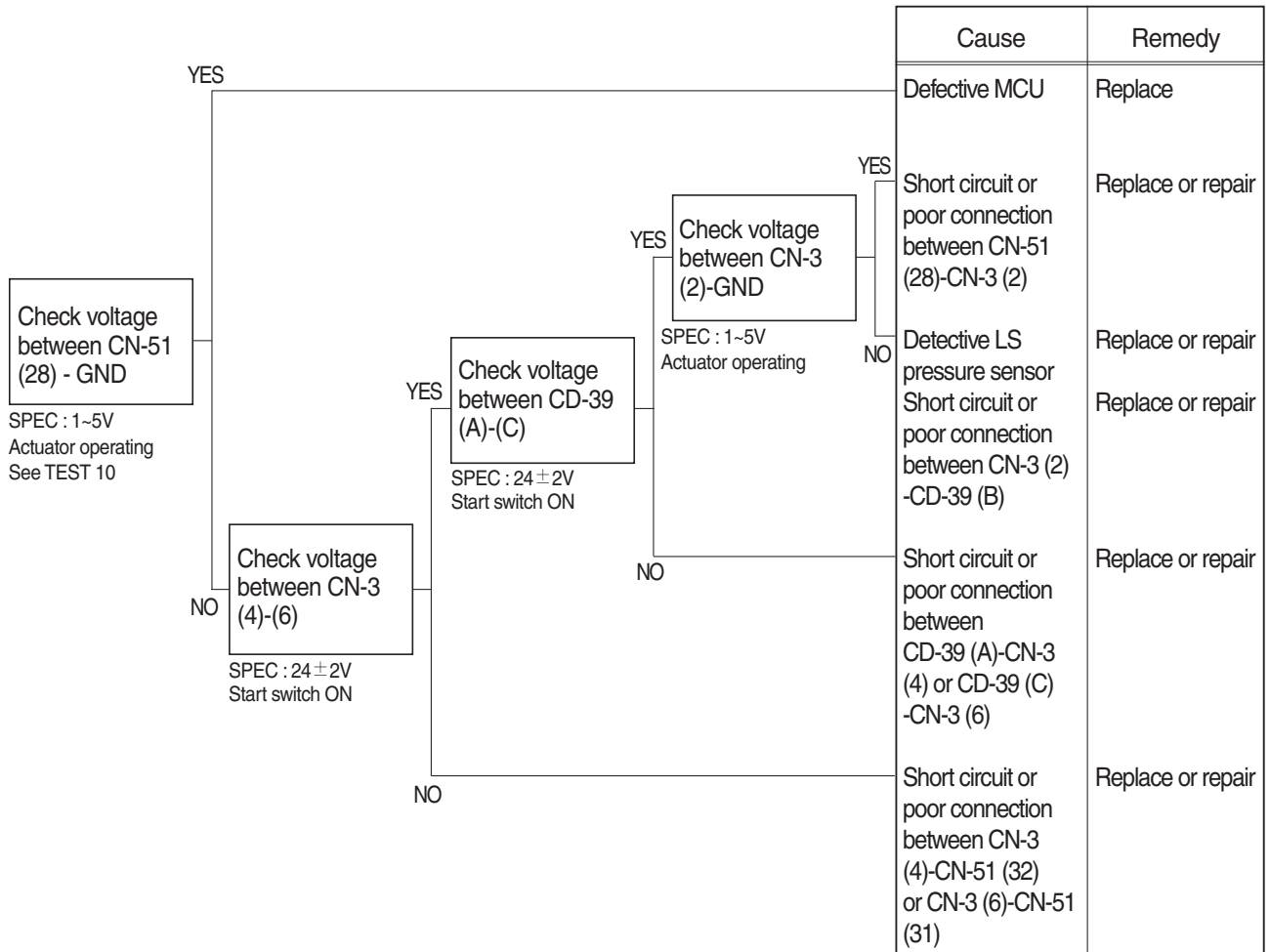

Wiring diagram

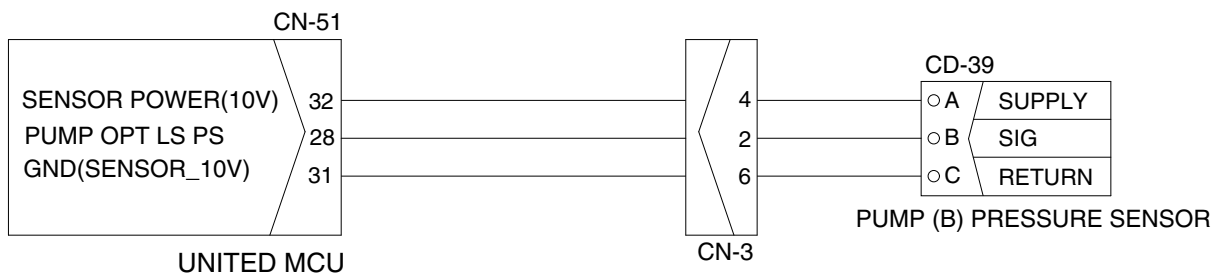

2) TEST PROCEDURE

(1) Test 10 : Check voltage at CN-51 (28) and ground.

- ① Prepare 1 piece of thin sharp pin, steel or copper.
- ② Insert prepared pin to rear side of connectors : One pin to (28) of CN-51.
- ③ Starting switch ON.
- ④ Check voltage as figure.

SPEC : Actuator operating : 1~5 V

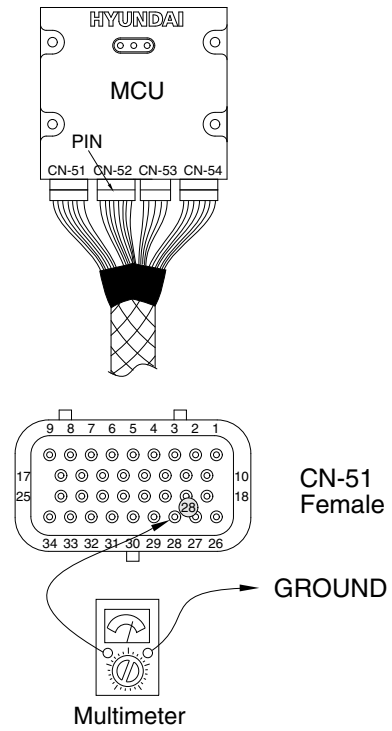

140WA6MS56

7. MALFUNCTION OF PUMP OPT PRESSURE SENSOR

· Fault code : HCESPN 125, FMI 0~4

※ Before carrying out below procedure, check all the related connectors are properly inserted.

1) INSPECTION PROCEDURE

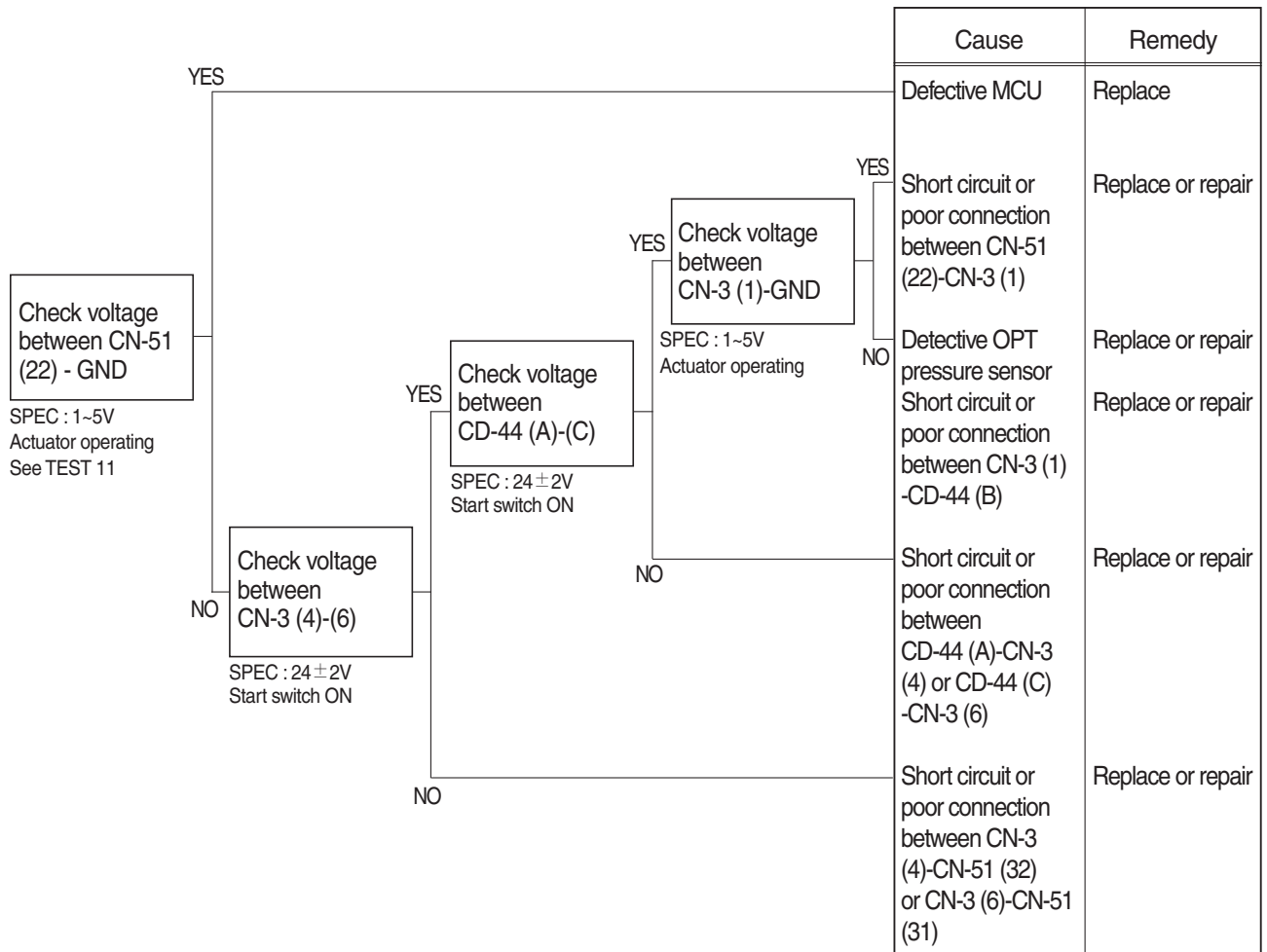

Wiring diagram

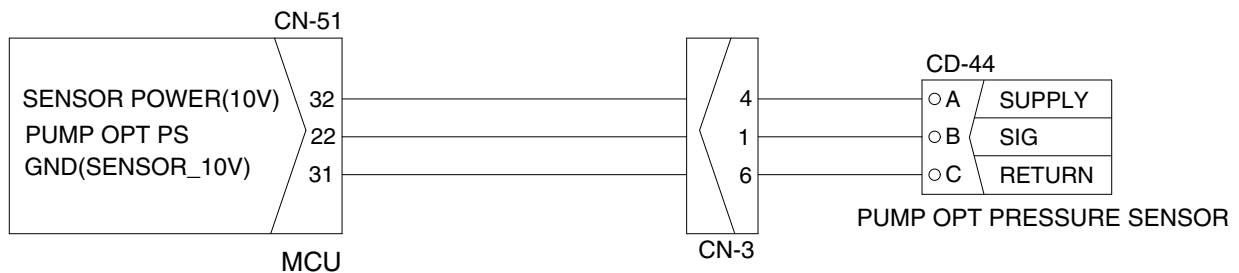

2) TEST PROCEDURE

(1) **Test 11** : Check voltage at CN-51 (22) and ground.

- ① Prepare 1 piece of thin sharp pin, steel or copper.
- ② Insert prepared pin to rear side of connectors : One pin to (22) of CN-51.
- ③ Starting switch ON.
- ④ Check voltage as figure.

SPEC : Actuator operating : 1~5 V

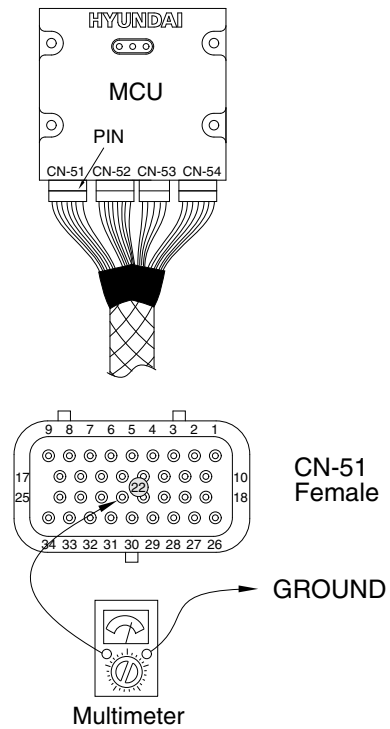

140WA6MS10

8. MALFUNCTION OF SWING PRESSURE SENSOR

· Fault code : HCESPN 135, FMI 0~4

※ Before carrying out below procedure, check all the related connectors are properly inserted.

1) INSPECTION PROCEDURE

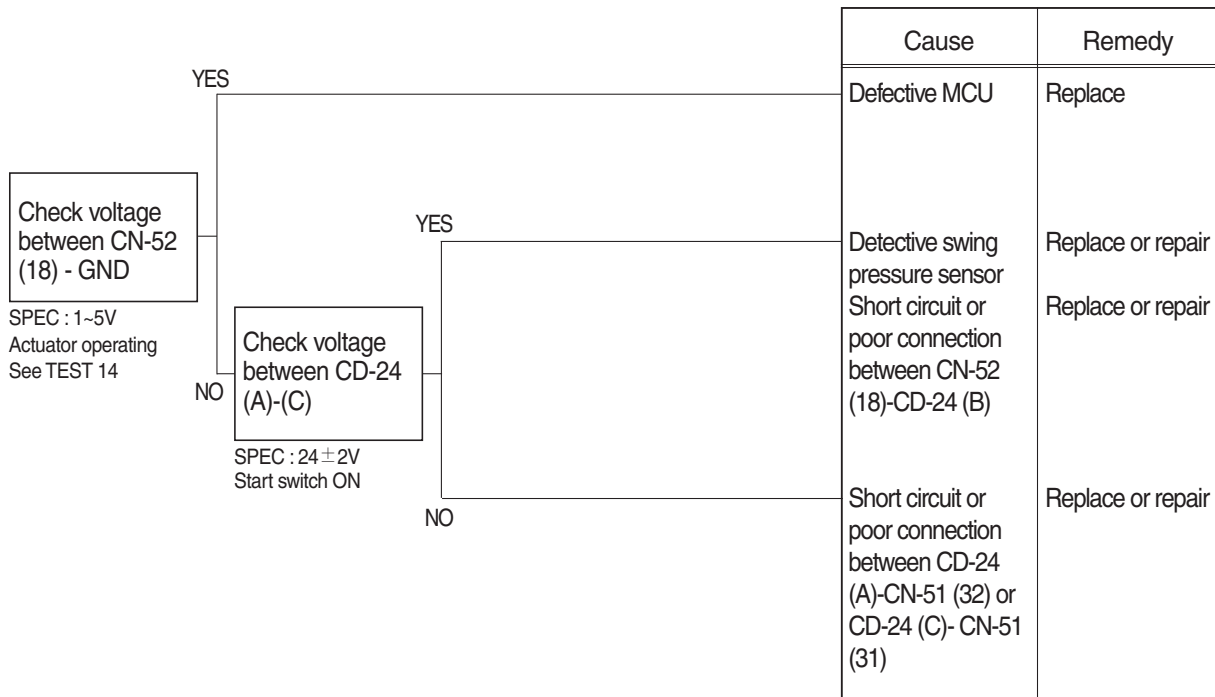

Wiring diagram

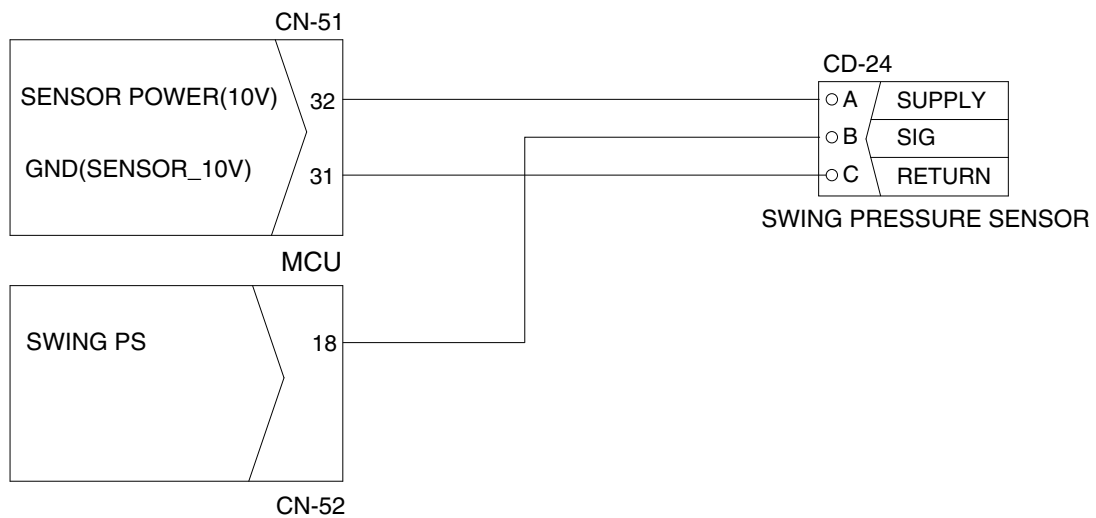

140WA6MS15

2) TEST PROCEDURE

(1) Test 14 : Check voltage at CN-52 (18) and ground.

- ① Prepare 1 piece of thin sharp pin, steel or copper.
- ② Insert prepared pin to rear side of connectors : One pin to (18) of CN-52.
- ③ Starting switch ON.
- ④ Check voltage as figure.

SPEC : Actuator operating : 1~5 V

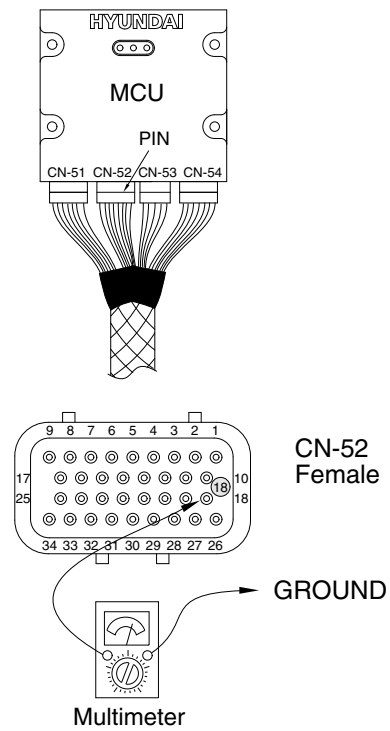

140WF6MS116

9. MALFUNCTION OF ARM OUT PRESSURE SENSOR

· Fault code : HCESPN 133, FMI 0~4

※ Before carrying out below procedure, check all the related connectors are properly inserted.

1) INSPECTION PROCEDURE

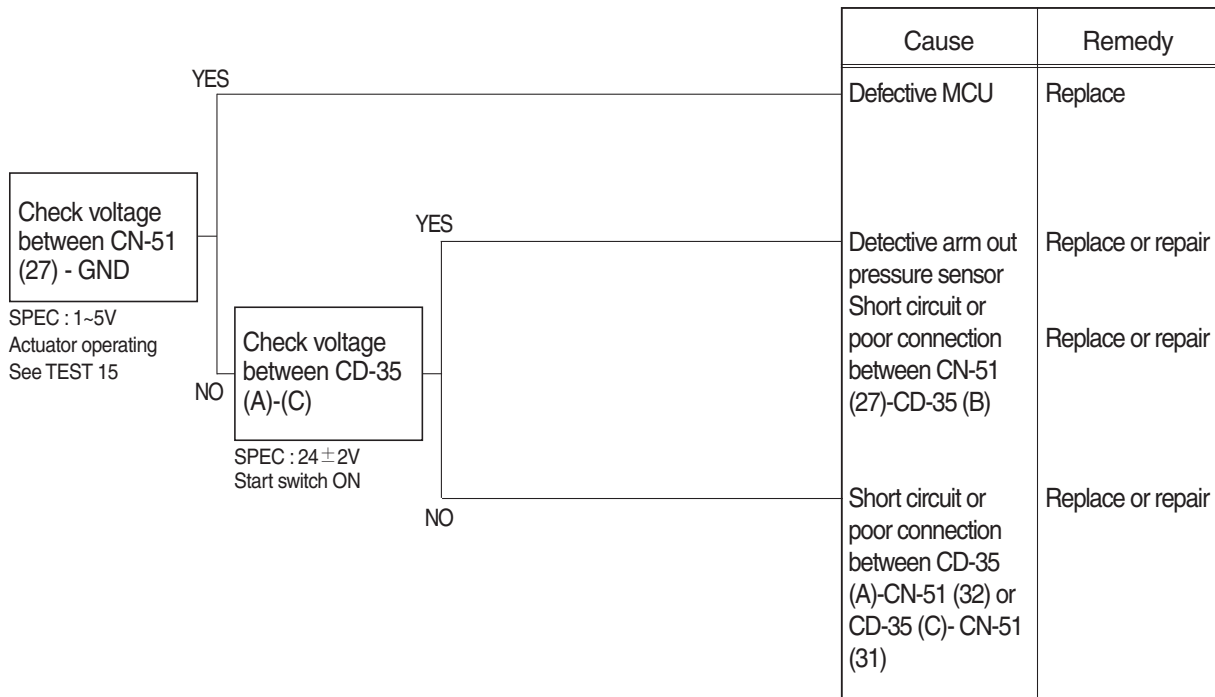

Wiring diagram

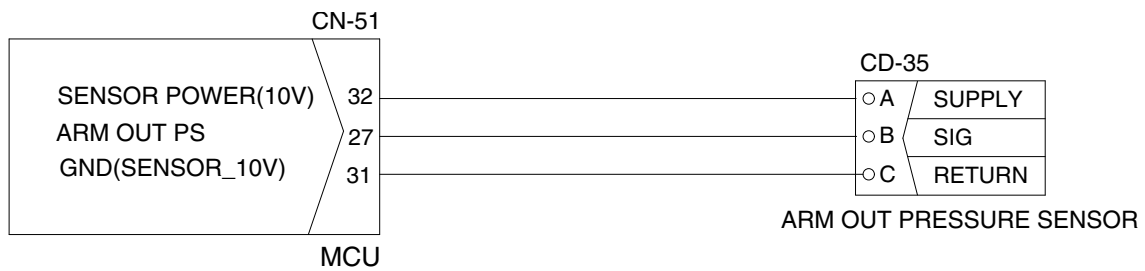

140WA6MS17

2) TEST PROCEDURE

(1) **Test 15** : Check voltage at CN-51 (27) and ground.

- ① Prepare 1 piece of thin sharp pin, steel or copper.
- ② Insert prepared pin to rear side of connectors : One pin to (27) of CN-51.
- ③ Starting switch ON.
- ④ Check voltage as figure.

SPEC : Actuator operating : 1~5 V

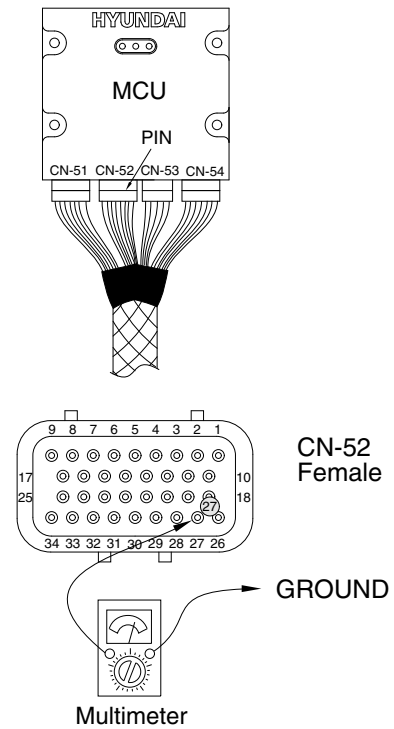

140WA6MS18

10. MALFUNCTION OF BOOM UP PRESSURE SENSOR

· Fault code : HCESPN 127, FMI 0~4

※ Before carrying out below procedure, check all the related connectors are properly inserted.

1) INSPECTION PROCEDURE

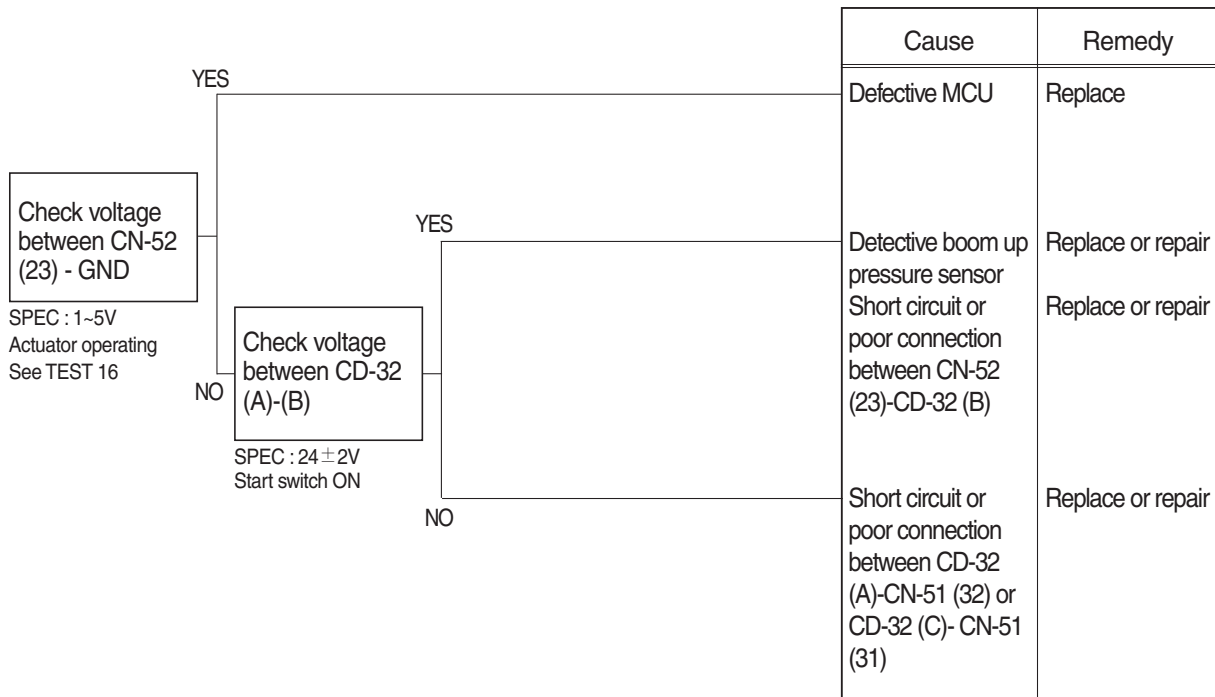

Wiring diagram

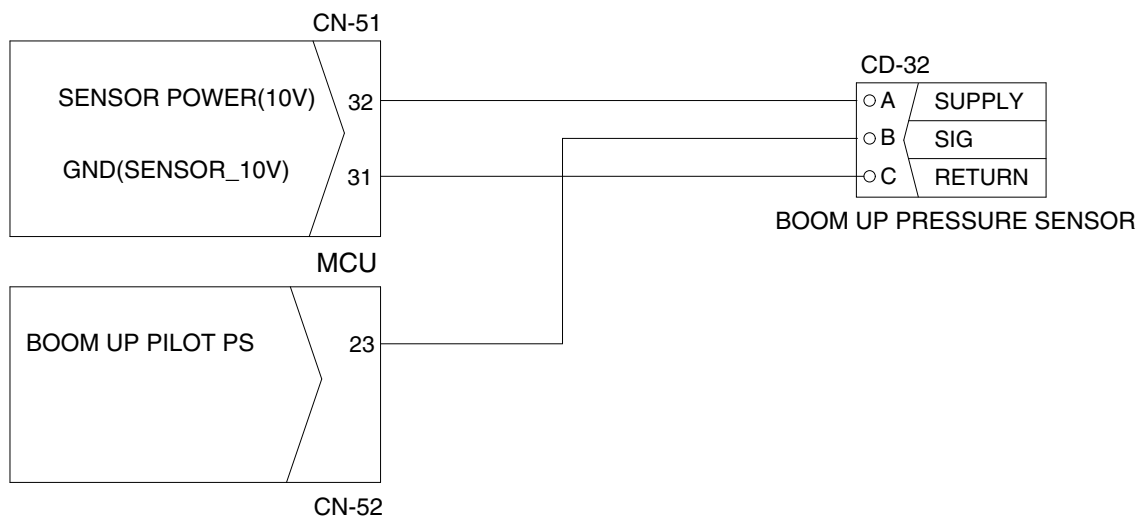

140WA6MS19

2) TEST PROCEDURE

(1) **Test 16** : Check voltage at CN-52 (23) and ground.

- ① Prepare 1 piece of thin sharp pin, steel or copper.
- ② Insert prepared pin to rear side of connectors : One pin to (23) of CN-52.
- ③ Starting switch ON.
- ④ Check voltage as figure.

SPEC : Actuator operating : 1~5 V

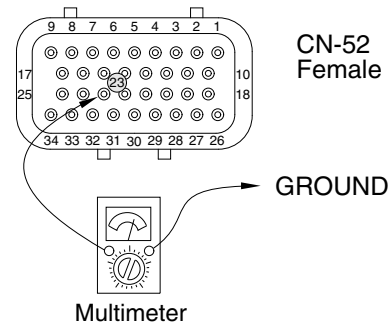
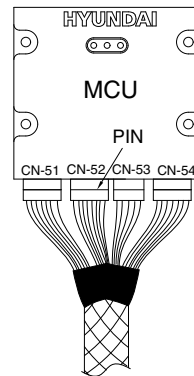

140WF6MS120

11. MALFUNCTION OF BOOM DOWN PRESSURE SENSOR

· Fault code : HCESPN 128, FMI 0~4

※ Before carrying out below procedure, check all the related connectors are properly inserted.

1) INSPECTION PROCEDURE

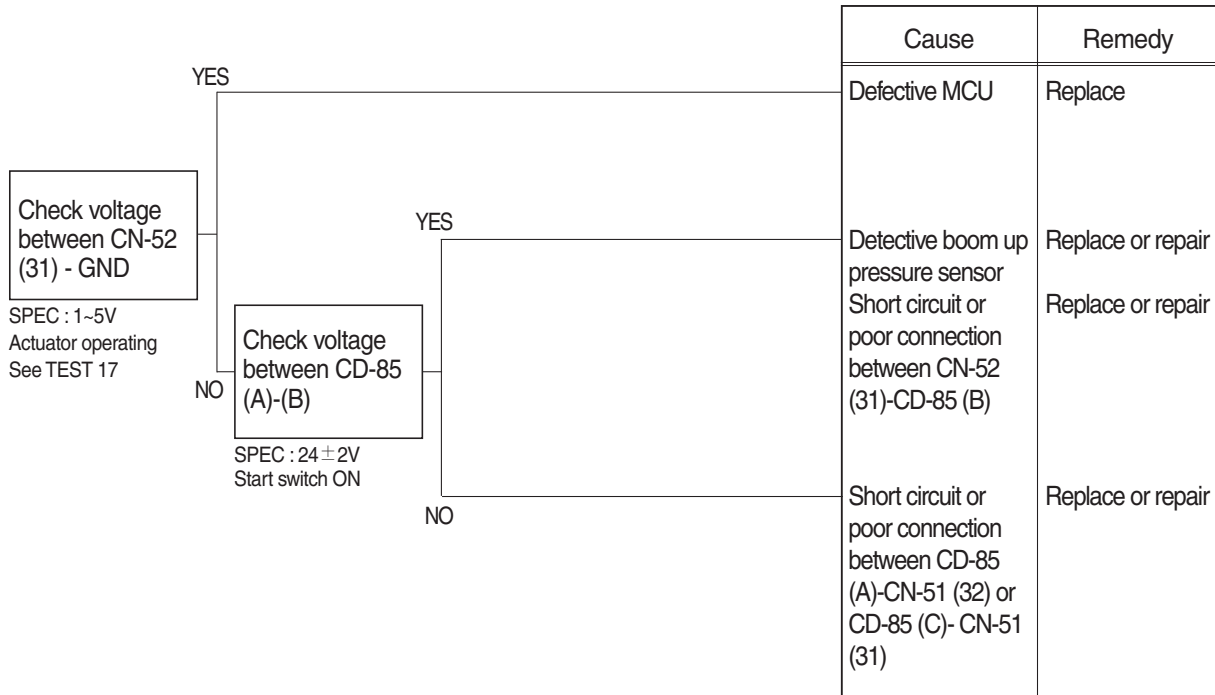

Wiring diagram

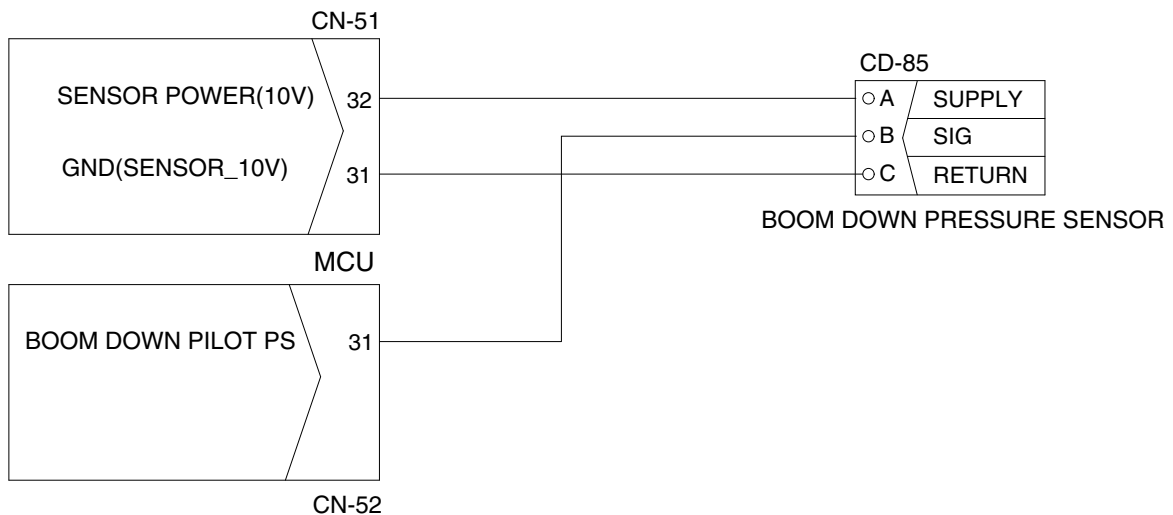

140WA6MS25

2) TEST PROCEDURE

(1) **Test 17** : Check voltage at CN-52 (31) and ground.

- ① Prepare 1 piece of thin sharp pin, steel or copper.
- ② Insert prepared pin to rear side of connectors : One pin to (31) of CN-52.
- ③ Starting switch ON.
- ④ Check voltage as figure.

SPEC : Actuator operating : 1~5 V

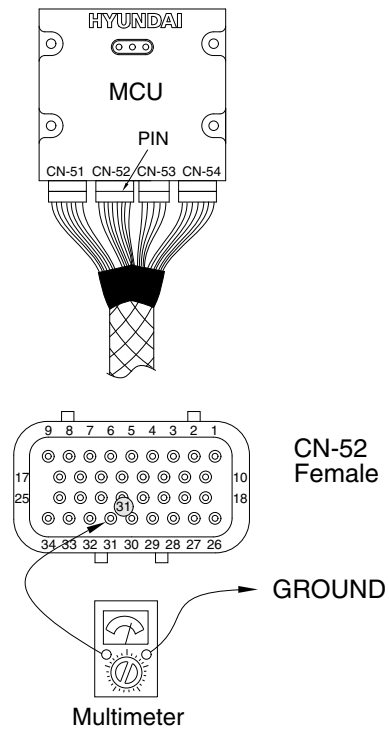

140WF6MS126

12. MALFUNCTION OF POWER MAX

· Fault code : HCESPN 166, FMI 4 or 6

※ Before carrying out below procedure, check all the related connectors are properly inserted.

1) INSPECTION PROCEDURE

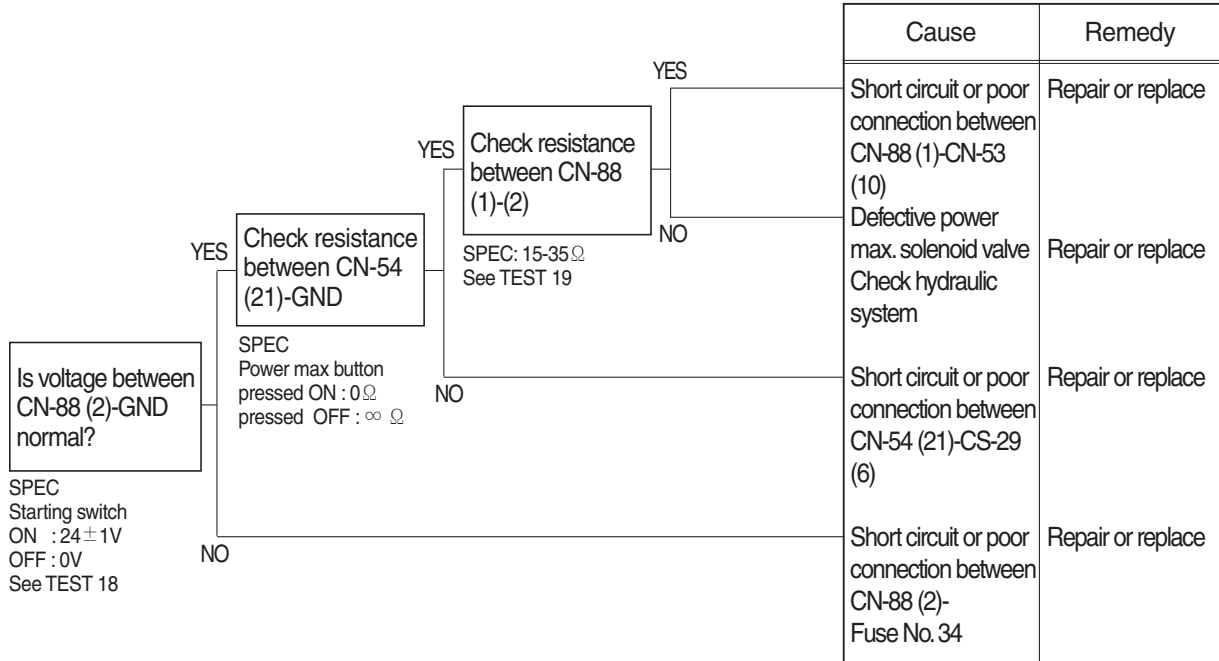

Wiring diagram

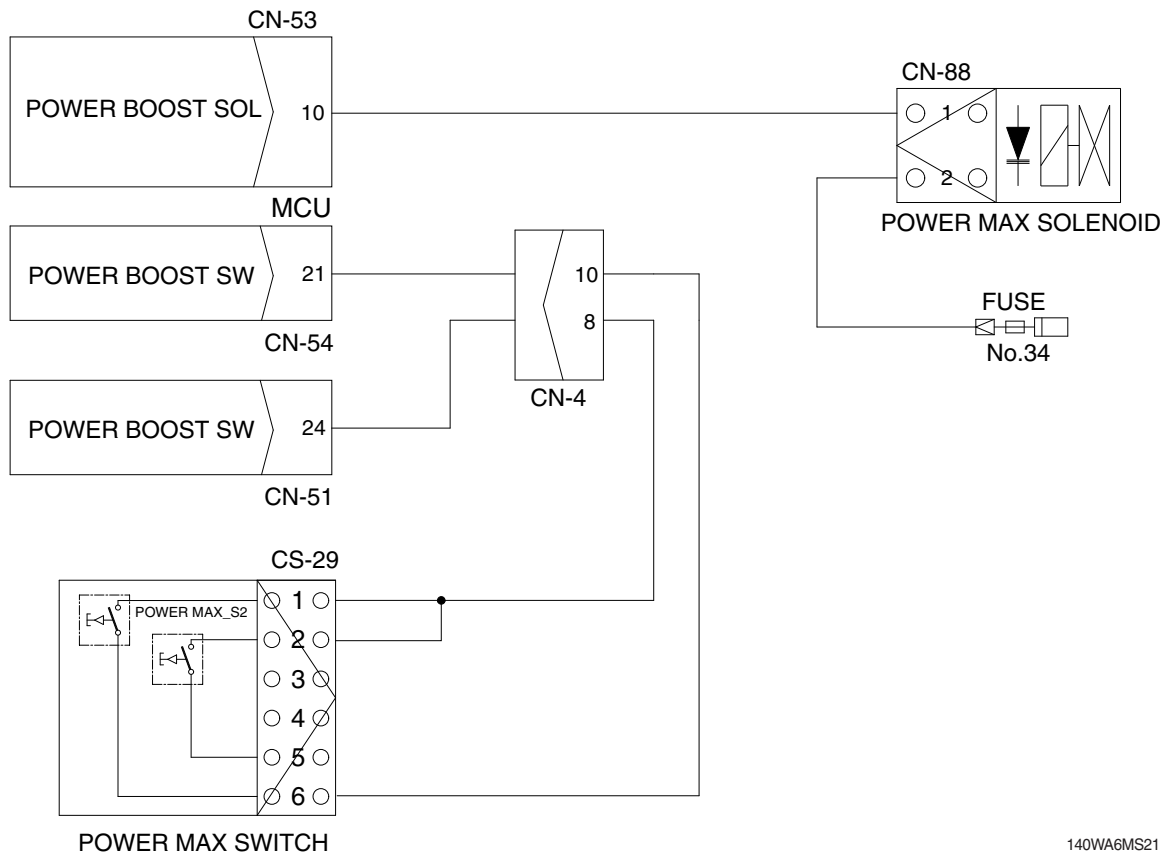

140WA6MS21

2) TEST PROCEDURE

(1) **Test 18:** Check voltage between connector CN-88 (2) - GND.

- ① Disconnect connector CN-88 from power max solenoid valve.
- ② Start switch ON.
- ③ Check voltage as figure.

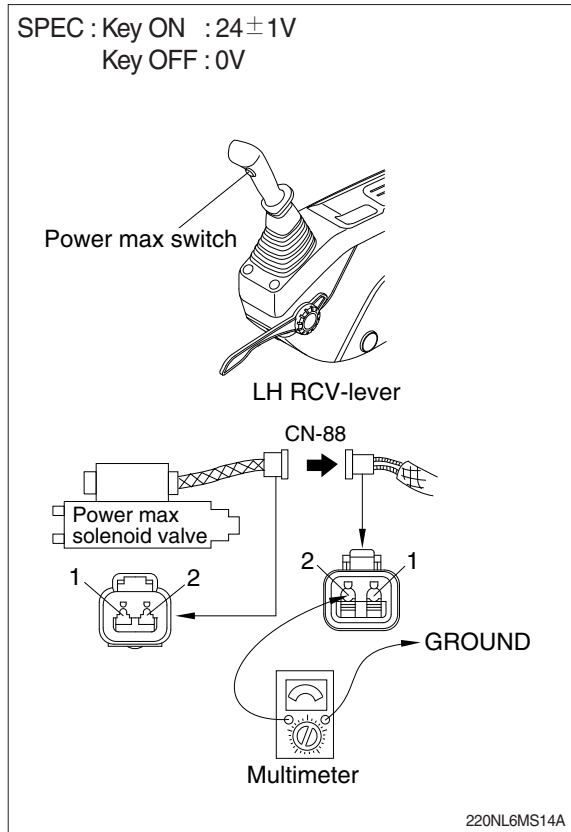

(2) **Test 19:** Check resistance of the solenoid valve between CN-88 (1)-(2).

- ① Starting key OFF.
- ② Disconnect connector CN-88 from power max solenoid valve.
- ③ Check resistance as figure.

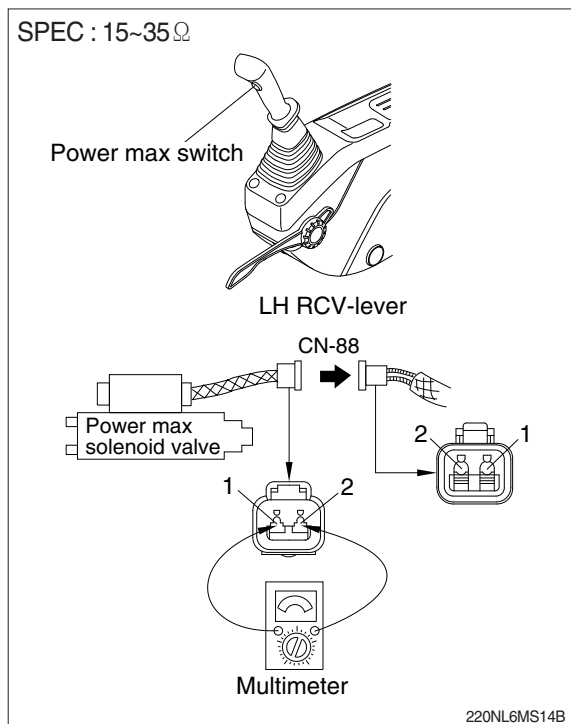

13. MALFUNCTION OF TRANSMISSION OIL PRESSURE SENSOR

· Fault code : HCESPN 501, FMI 0~4

※ Before carrying out below procedure, check all the related connectors are properly inserted.

1) INSPECTION PROCEDURE

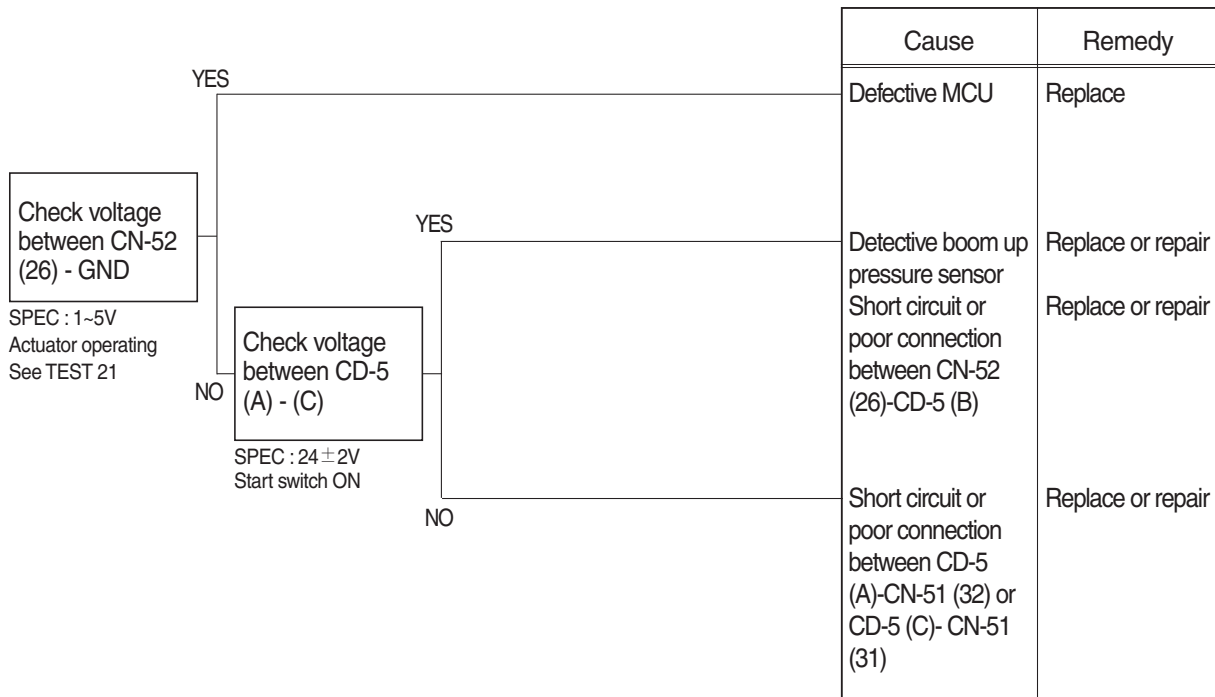

Wiring diagram

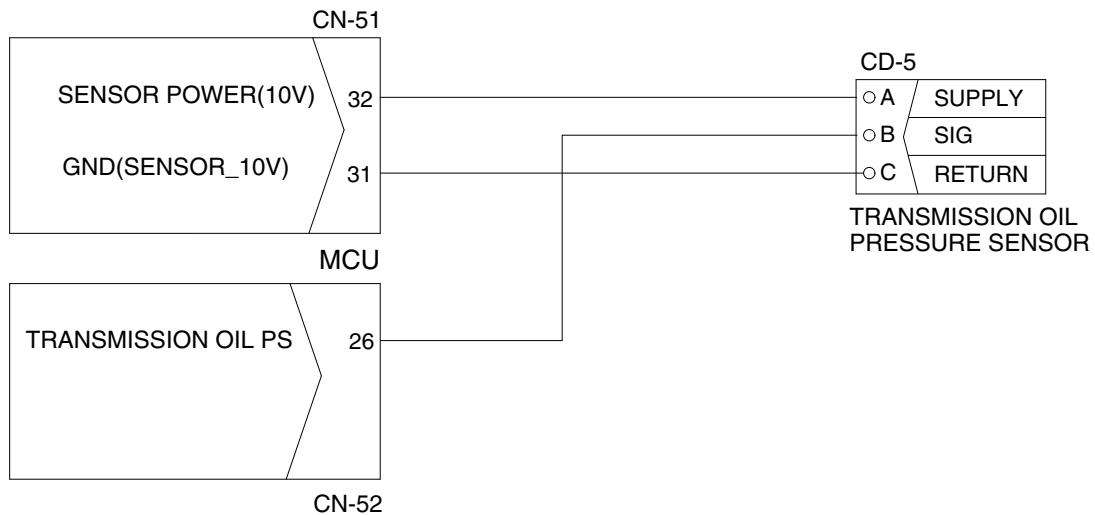

140WA6MS60

2) TEST PROCEDURE

(1) **Test 21** : Check voltage at CN-52 (26) and ground.

- ① Prepare 1 piece of thin sharp pin, steel or copper.
- ② Insert prepared pin to rear side of connectors : One pin to (26) of CN-52.
- ③ Starting switch ON.
- ④ Check voltage as figure.

SPEC : Actuator operating : 1~5 V

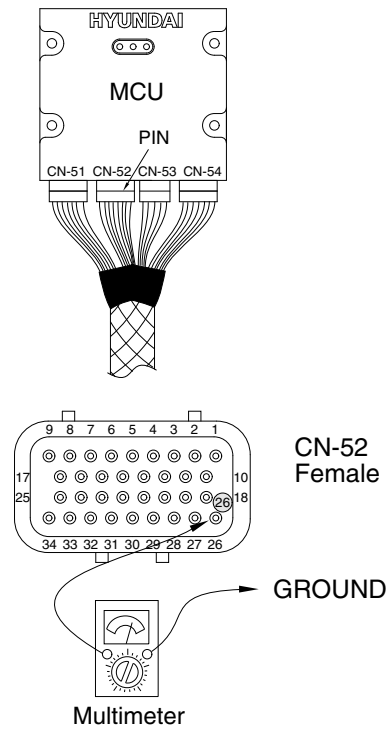

140WF6MS161

14. MALFUNCTION OF BRAKE OIL PRESSURE SENSOR

· Fault code : HCESPN 503, FMI 0~4

※ Before carrying out below procedure, check all the related connectors are properly inserted.

1) INSPECTION PROCEDURE

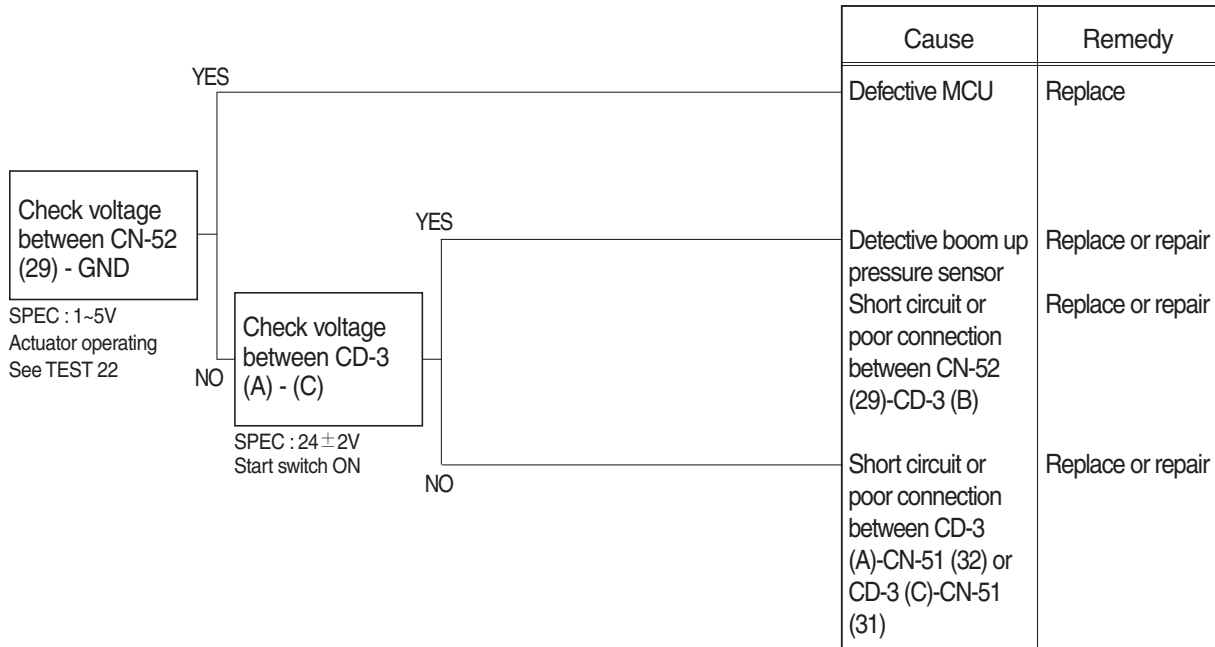

Wiring diagram

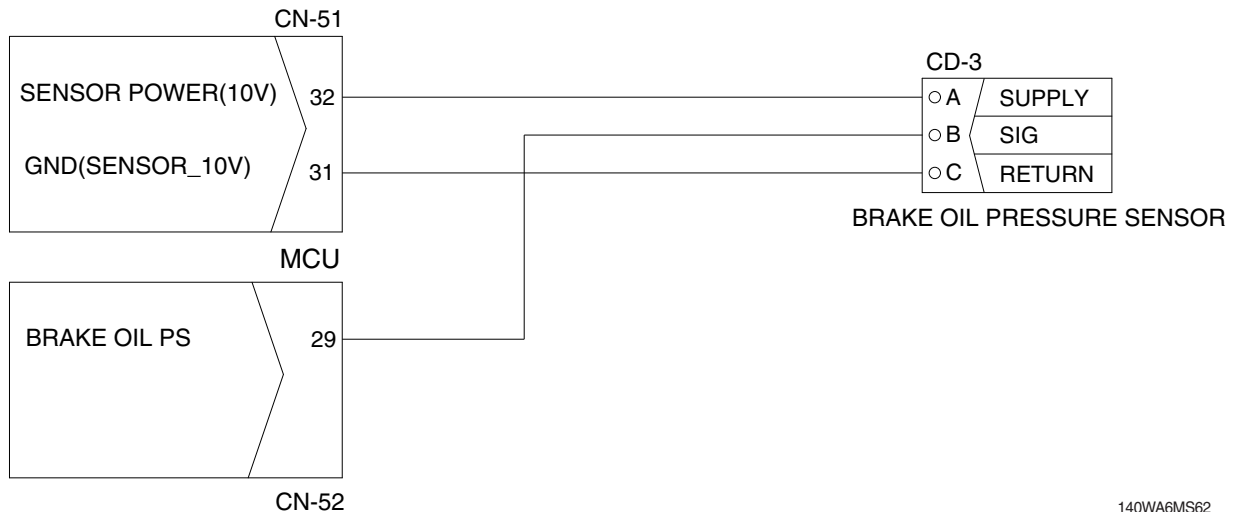

140WA6MS62

2) TEST PROCEDURE

(1) **Test 22** : Check voltage at CN-52 (29) and ground.

- ① Prepare 1 piece of thin sharp pin, steel or copper.
- ② Insert prepared pin to rear side of connectors : One pin to (29) of CN-52.
- ③ Starting switch ON.
- ④ Check voltage as figure.

SPEC : Actuator operating : 1~5 V

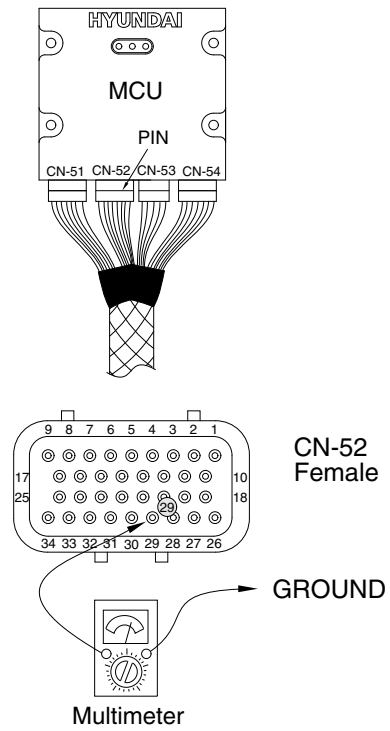

140WF6MS163

15. MALFUNCTION OF TRAVEL FORWARD PRESSURE SENSOR

· Fault code : HCESPN 530, FMI 0~4

※ Before carrying out below procedure, check all the related connectors are properly inserted.

1) INSPECTION PROCEDURE

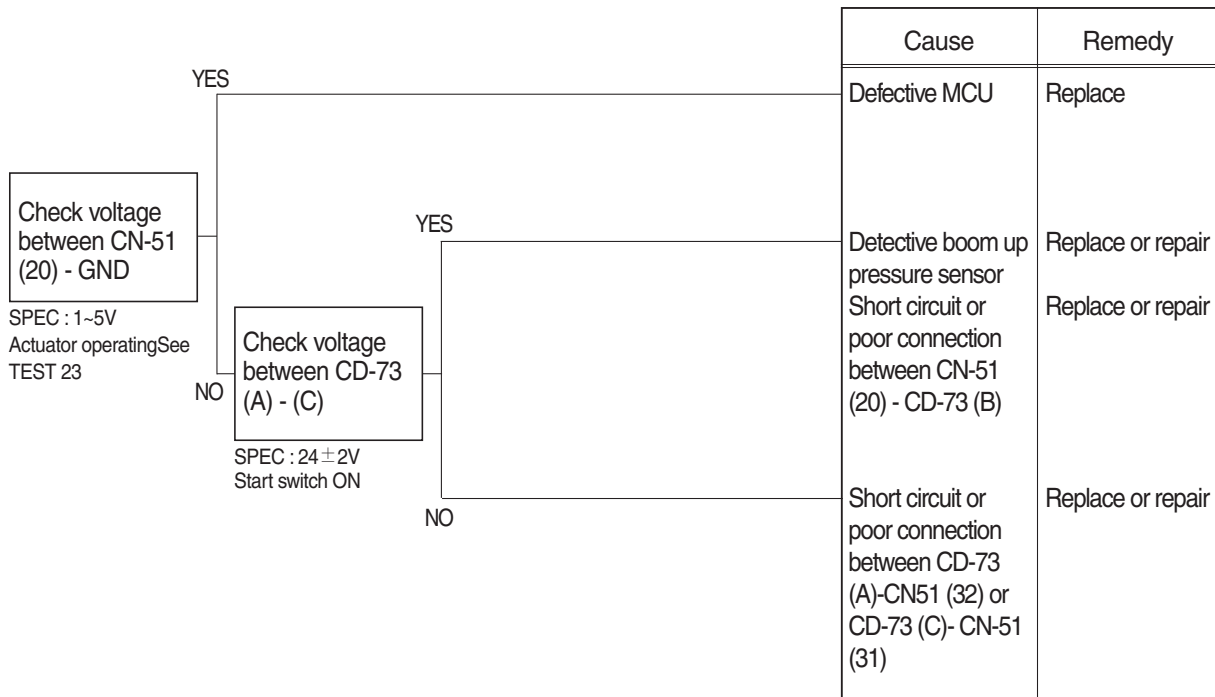

Wiring diagram

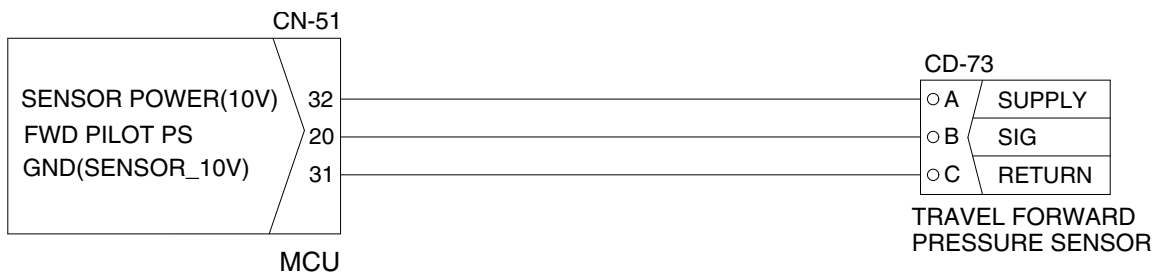

140WA6MS64

2) TEST PROCEDURE

(1) **Test 23** : Check voltage at CN-51 (20) and ground.

- ① Prepare 1 piece of thin sharp pin, steel or copper.
- ② Insert prepared pin to rear side of connectors : One pin to (20) of CN-51.
- ③ Starting switch ON.
- ④ Check voltage as figure.

SPEC : Actuator operating : 1~5 V

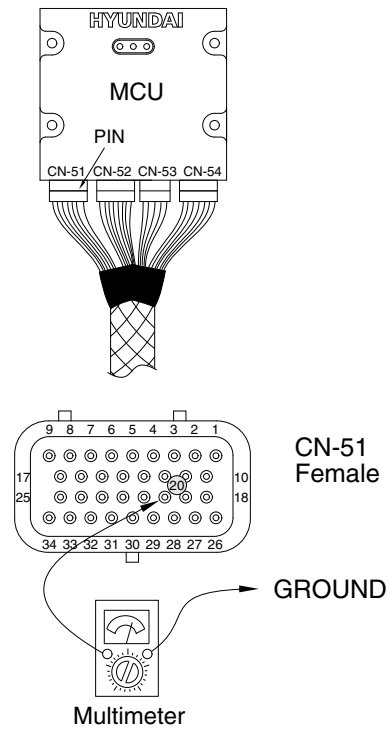

140WF6MS165

16. MALFUNCTION OF RAM LOCK SOLENOID

· Fault code : HCESPN 525, FMI 4 or 6

※ Before carrying out below procedure, check all the related connectors are properly inserted.

1) INSPECTION PROCEDURE

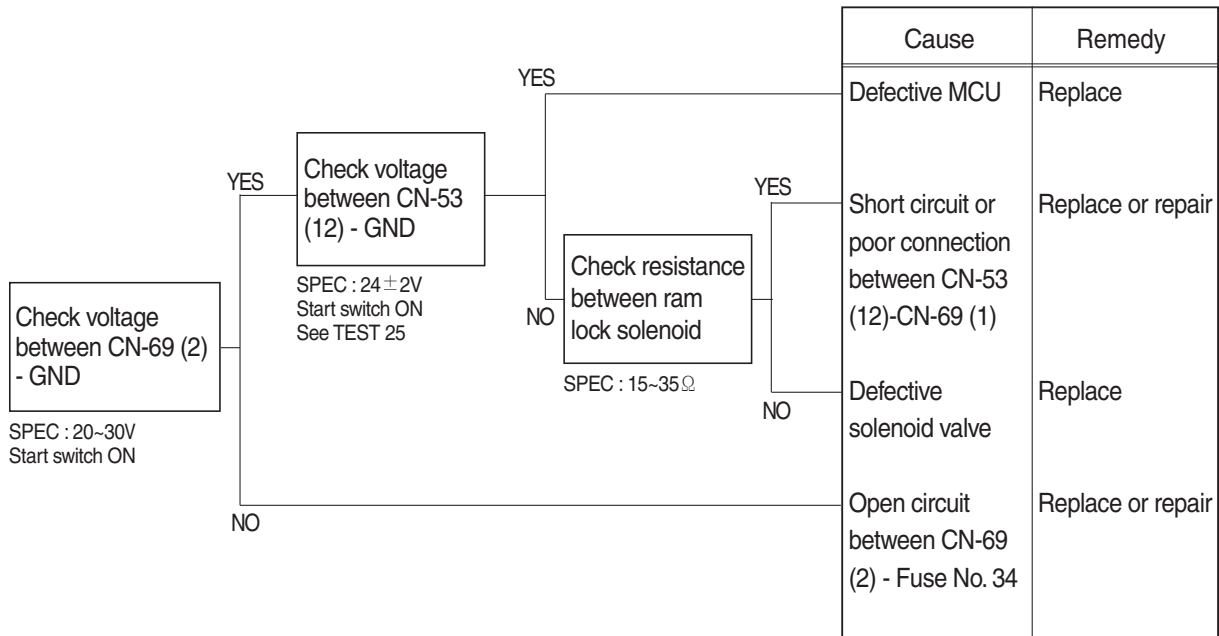

Wiring diagram



140WA6MS68

2) TEST PROCEDURE

(1) **Test 25** : Check voltage at 53 (12) and ground.

- ① Prepare 1 piece of thin sharp pin, steel or copper.
- ② Insert prepared pin to rear side of connectors : One pin to (12) of CN-53.
- ③ Starting switch ON.
- ④ Check voltage as figure.

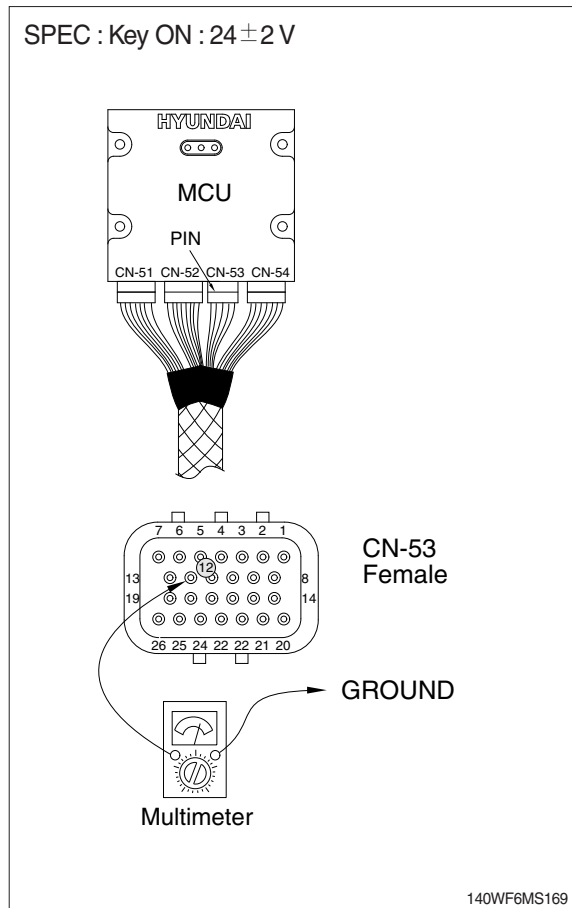

GROUP 5 AIR CONDITIONER & HEATER SYSTEM

1. AIR CONDITIONER DOES NOT OPERATE

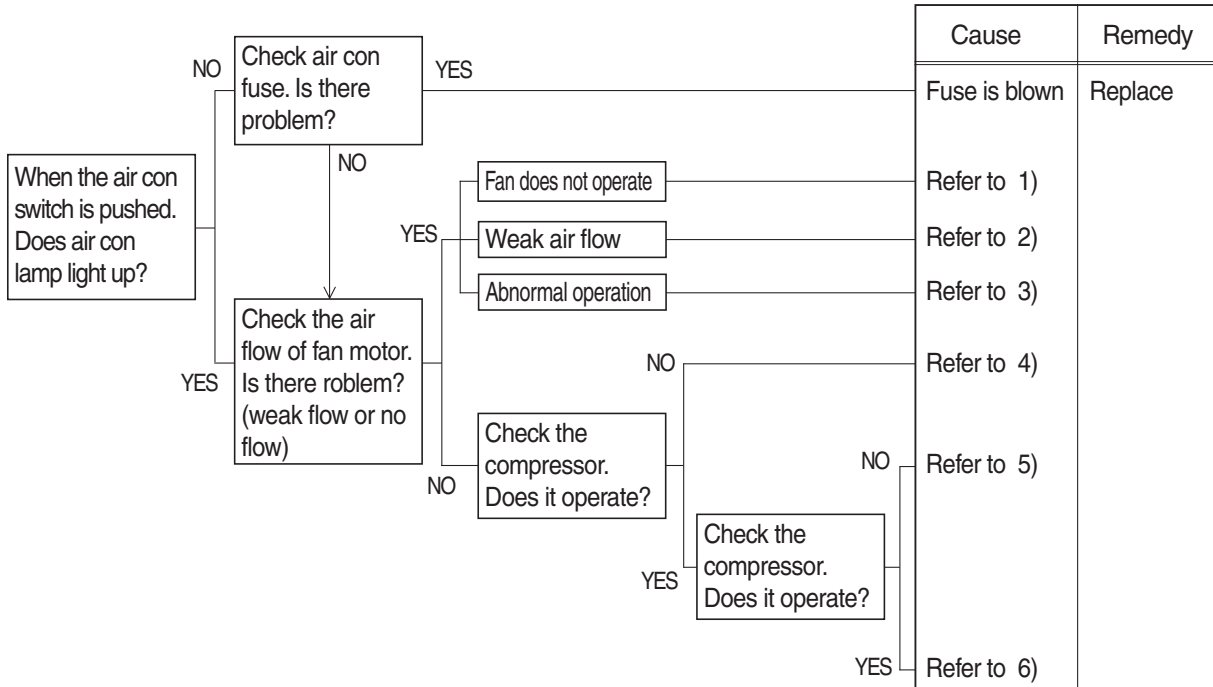

1) FAN DOES NOT OPERATE

Cause	Check	Remedy
Fuse is blown or abnormal relay operation	* Fuse * Does relay normally operate?	Replace
Harness short or poor contact	Check any harness short or abnormal contact of connector	Repair shortage
Fan motor failure	Supply 24V to 2 lead wire from motor and check the operation	Replace
Resistor is broken	Check current flow of resistor with tester	Replace
Fan switch failure	Push fan switch by turn and check the operation	Replace

2) WEAK AIR FLOW FROM FAN MOTOR

Cause	Check	Remedy
Clogged evaporator or obstacles around air inlet	Check if evaporator is contaminated	Clean
Leakage of air flow	Check HVAC case assembly	Adjust
Duct sensor failure	Check if evaporator is frozen	Replace

3) ABNORMAL OPERATION OF FAN MOTOR

Cause	Check	Remedy
Abnormal operation of each step of control	4 step only operate	Replace resistor
	1 or 2 step does not operate	Replace control
	3 or 4 step does not operate	Replace relay

4) COMPRESSOR DOES NOT ROTATE OR HARDLY ROTATE

Cause	Check	Remedy
Loose belt	Belt shaking is severe	Adjust tension
Failure of compressor itself	Belt slip	Repair or Replace
Low voltage of battery	Slip when rotate	Charge battery
Fieldcoil short	Slip when rotate	Replace magnetic clutch
Oily clutch face	Contamination around clutch	Replace magnetic clutch, clean
Fieldcoil is broken	Magnetic clutch does not operate or " ∞ " resistance	Replace compressor
Leakage of refrigerant or oil inside	Check if wet with oil	Replace compressor Charge refrigerant

5) COMPRESSOR OPERATE NORMALLY AND AIR FLOW IS NORMAL

Cause	Check	Remedy
Shortage of refrigerant	When air con operate during 5~10 min small temperature difference between high and low pressure pipes.	Repair leakage joint Charge refrigerant
Overcharge of refrigerant	*Magnetic clutch on/off rapidly *High pressure over specification *Lukewarm air from nozzle	Recharge refrigerant following specification
Lower pressure than normal condition at low side	Shortage of refrigerant	Make up refrigerant
	Clogged receive dryer	Replace receive dryer
	Clogged expansion valve	Replace expansion valve
	Clogged or crushed pipe	Replace pipe or clean
	Failure of duct sensor	Replace duct sensor

6) COMPRESSOR OPERATE NORMALLY AND AIR FLOW IS NORMAL

Cause	Check	Remedy
Lower pressure than normal condition at low side	Failure of duct sensor Magnetic clutch off before air temperature sufficiently down	Replace duct sensor or adjust location
	Defective compressor gasket When compressor off, high and low pressure balance immediatly	Repair compressor or Replace
Higher pressure than normal condition at high side	Failure of condensing Contamination on condenser or insufficient air flow from fan	Clean the condenser Repair fan
	Overcharge of refrigerant	Adjust refrigerant
	Entrained air	Vacuum and recharge
Lower pressure than normal condition at high side	Shortage of refrigerant	Make up refrigerant