

SECTION 4 ELECTRICAL SYSTEM

Group 1 Component Location	4-1
Group 2 Electrical Circuit	4-3
Group 3 Electrical Component Specification	4-25
Group 4 Connectors	4-38

GROUP 1 COMPONENT LOCATION

1. LOCATION 1

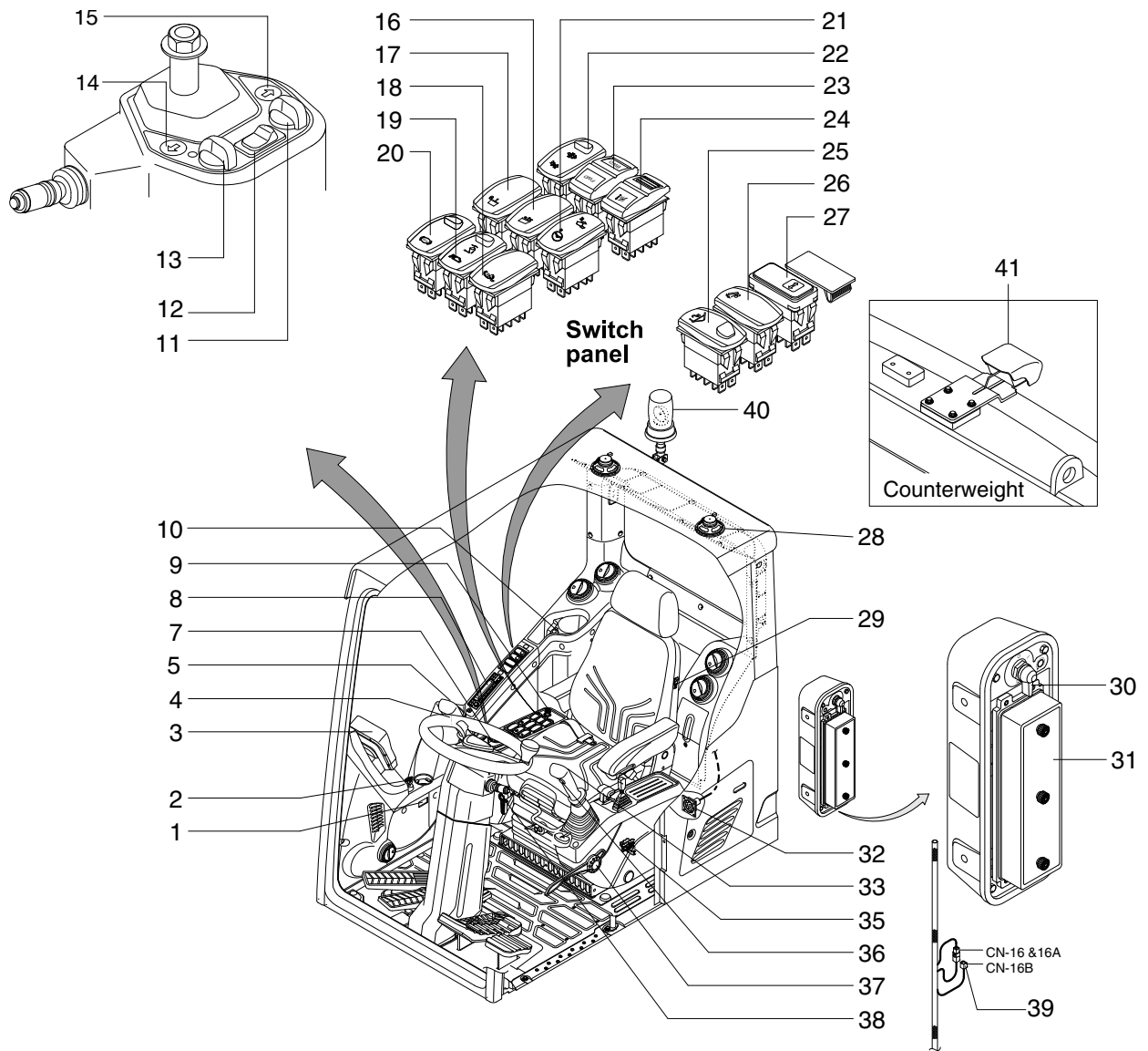

150WA4EL01

- | | | |
|----------------------------|--|---|
| 1 Service meter | 15 Right turn pilot lamp | 29 Seat heater switch |
| 2 Start switch | 16 Free/fine swing switch | 30 Master switch |
| 3 Cluster | 17 Swing lock switch | 31 Fuse & relay box |
| 4 FNR switch | 18 Auto cruise switch | 32 RS232 & J1939 service socket |
| 5 Horn switch | 19 Boom floating & ride control switch | 33 One touch decel switch |
| 5 Quick clamp switch | 20 Auto brake switch | 33 Ram lock switch |
| 5 Breaker operation switch | 21 E/steering & crusher switch | 35 Emergency engine stop switch |
| 7 Jog dial module | 22 Exhaust system cleaning switch | 36 Power max switch |
| 8 Radio & USB player | 23 FNR switch (emergency) | 37 Safety knob |
| 9 Cigar lighter | 24 FNR select switch (emergency) | 38 Multi function switch (LH) |
| 10 Socket assy | 25 Quick clamp switch | 39 Emergency engine speed control connector |
| 11 Ram lock rotary switch | 26 Lift trailer Quick clamp switch | 40 Beacon lamp |
| 12 Hazard switch | 27 Trailer pilot lamp | 41 Rear view camera |
| 13 Select rotary switch | 28 Speaker | 42 Socket assy |

2. LOCATION 2

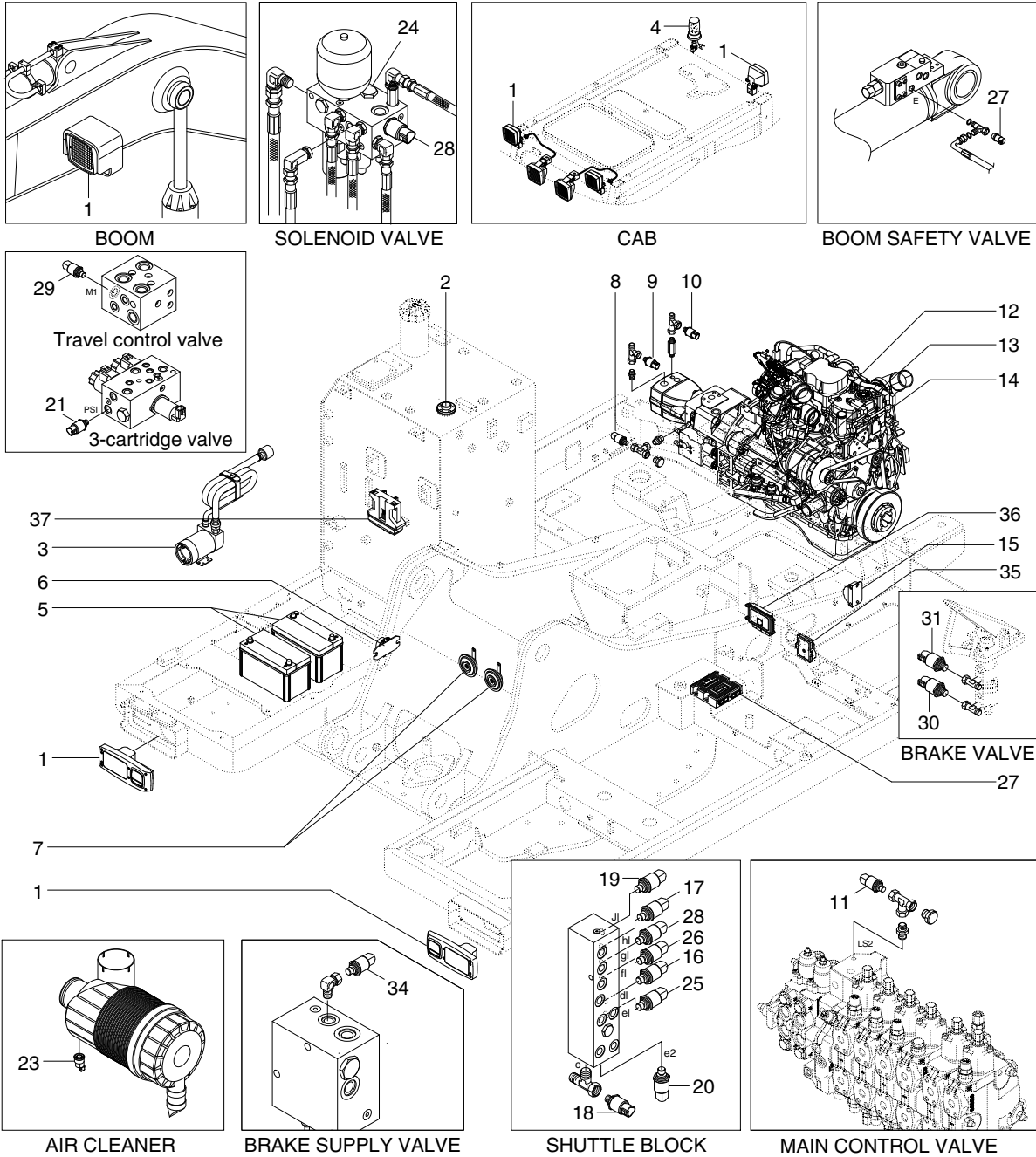

150WA4EL02

- | | | |
|---|-----------------------------------|---|
| 1 Lamp | 12 Start relay | 26 Bucket in pressure sensor |
| 2 Fuel sender | 13 Heater relay | 27 Overload pressure sensor |
| 3 Fuel filler pump | 14 Alternator | 28 Pilot oil pressure sensor |
| 4 Beacon lamp | 15 Travel alarm buzzer | 29 Travel control valve pressure sensor |
| 5 Battery | 16 Arm out pressure sensor | 30 Brake pressure sensor |
| 6 Battery relay | 17 Boom up pressure sensor | 31 Brake pilot lamp pressure switch |
| 7 Horn | 18 Swing pressure sensor | 32 MCU |
| 8 Main pump pressure sensor | 19 Boom down pressure sensor | 34 Brake supply valve pressure sensor |
| 9 Steering pump pressure sensor | 20 Arm in pressure sensor | 35 RDU assy |
| 10 Steering load sensing pressure sensor | 21 Travel pressure sensor | 36 View controller |
| 11 Main pump load sensing pressure sensor | 22 Bucket out pressure sensor | |
| | 23 Air cleaner sensor | |
| | 24 4 cartridge valve | |
| | 25 Swing & arm in pressure sensor | |

GROUP 2 ELECTRICAL CIRCUIT

ELECTRICAL CIRCUIT (1/3)

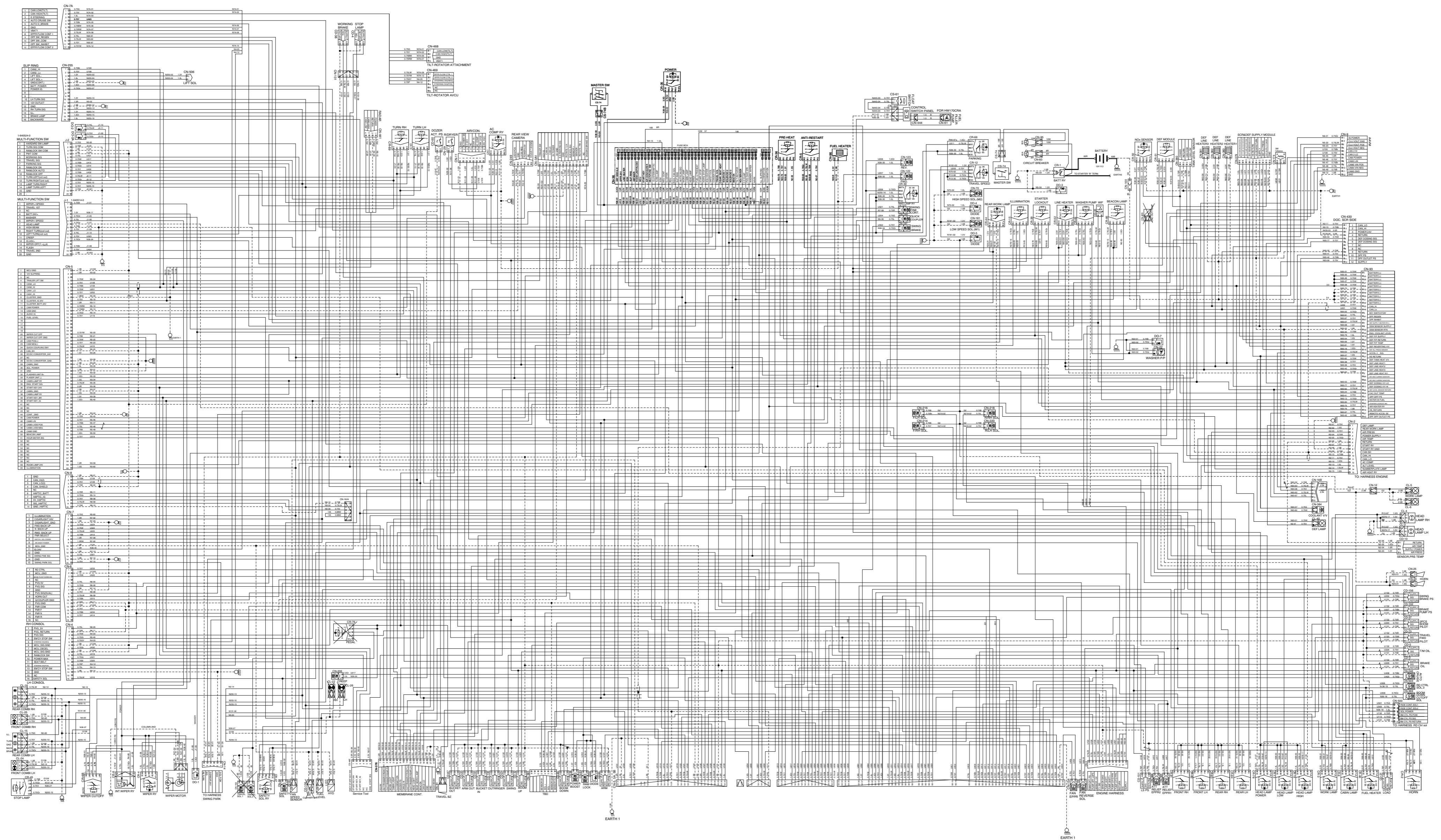

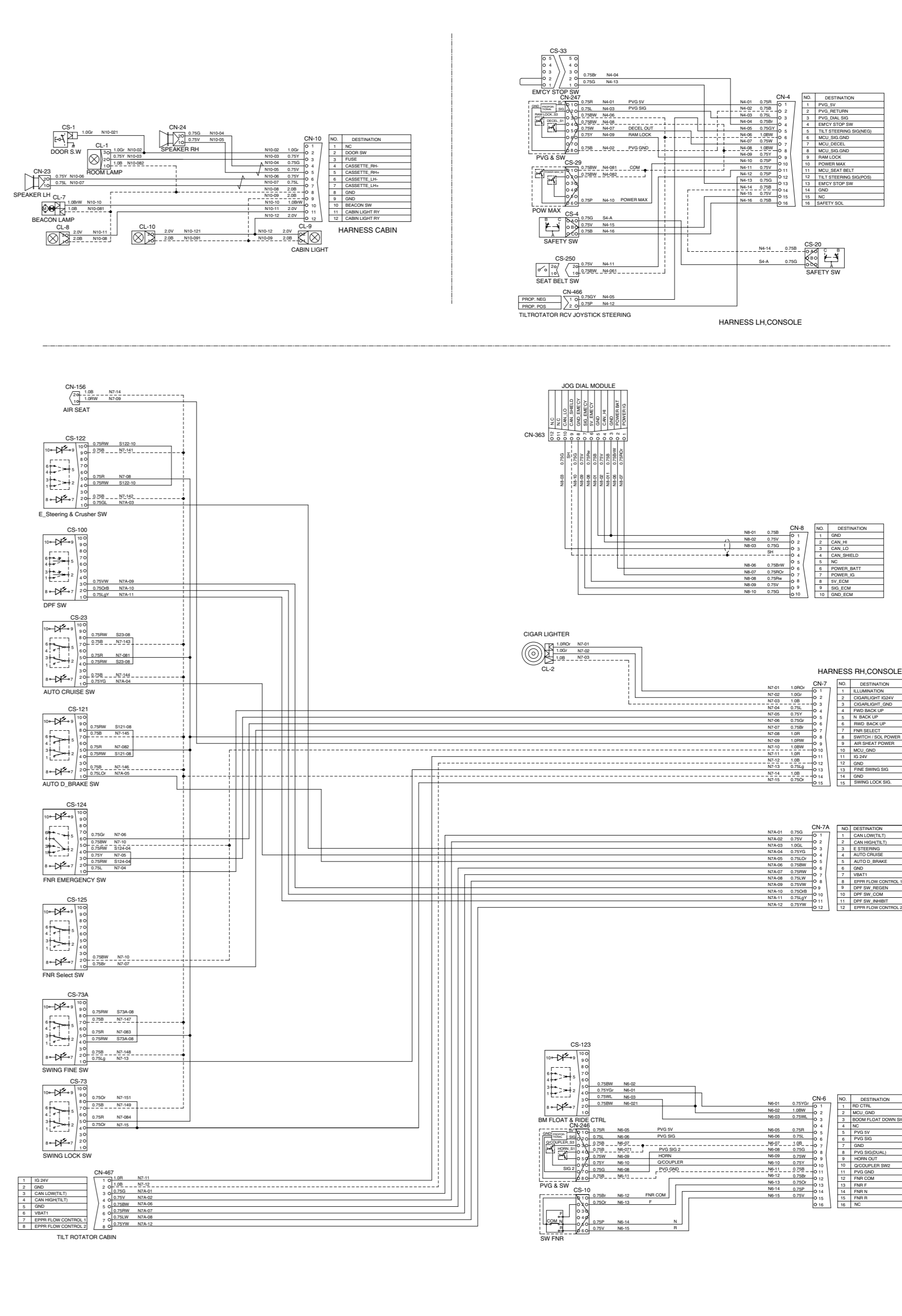
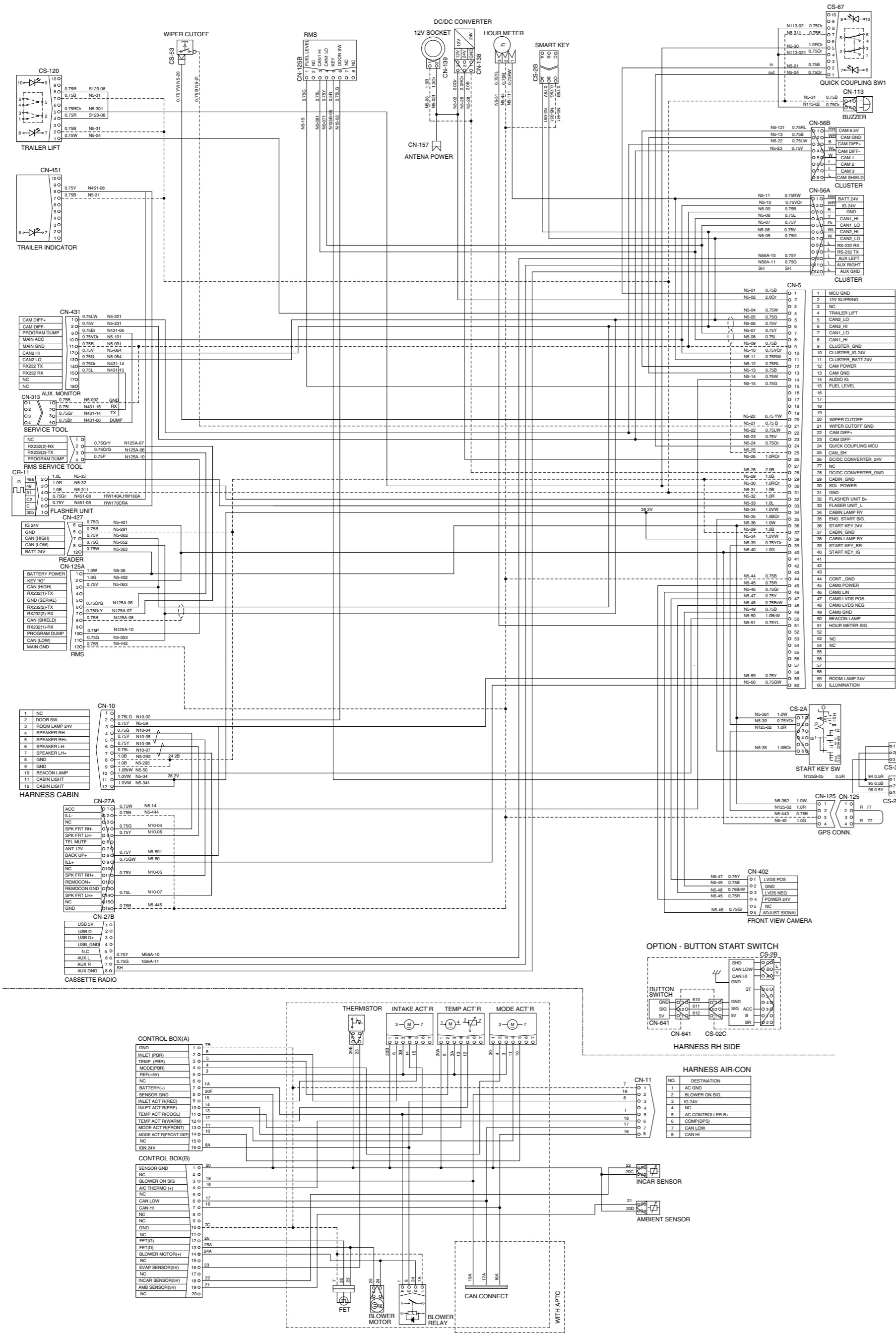

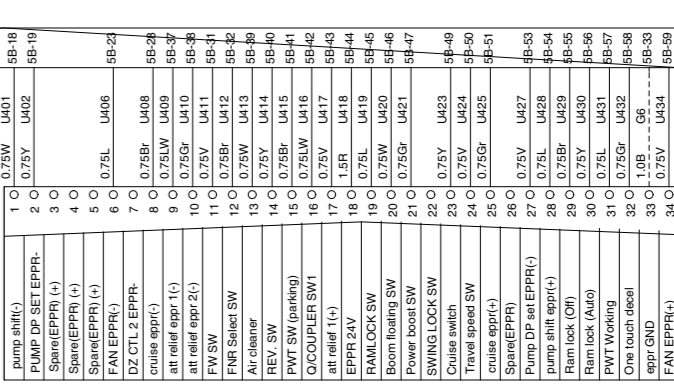
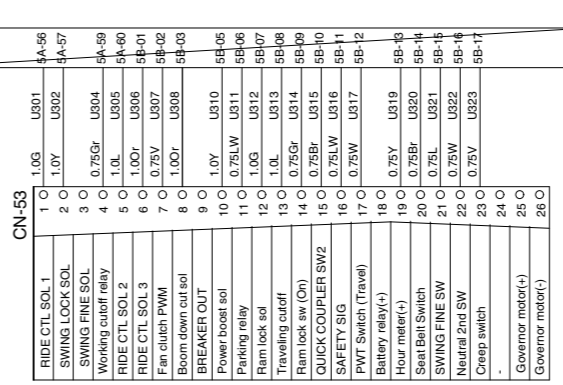
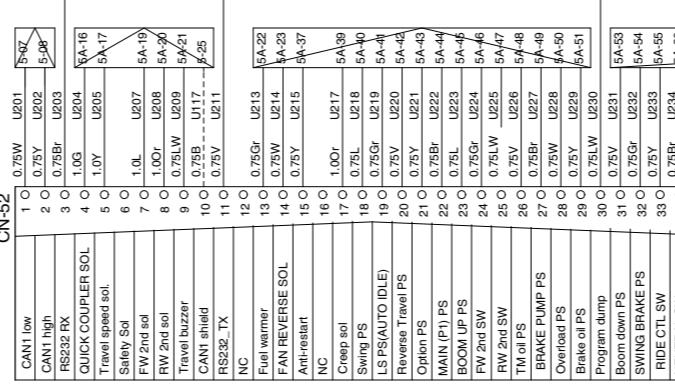
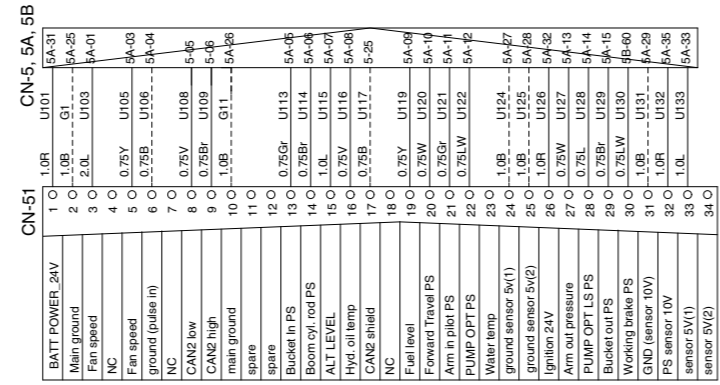
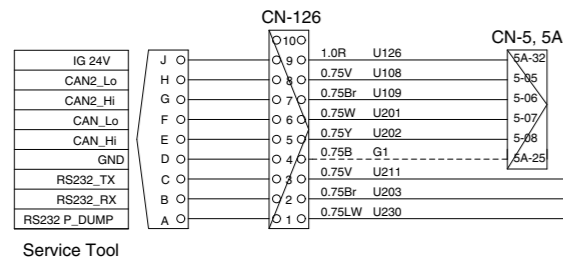
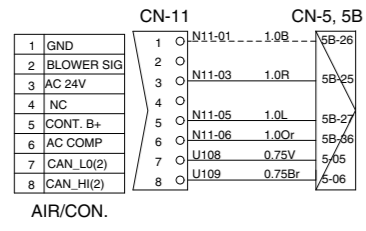

MCU

ELECTRICAL CIRCUIT (3/3)

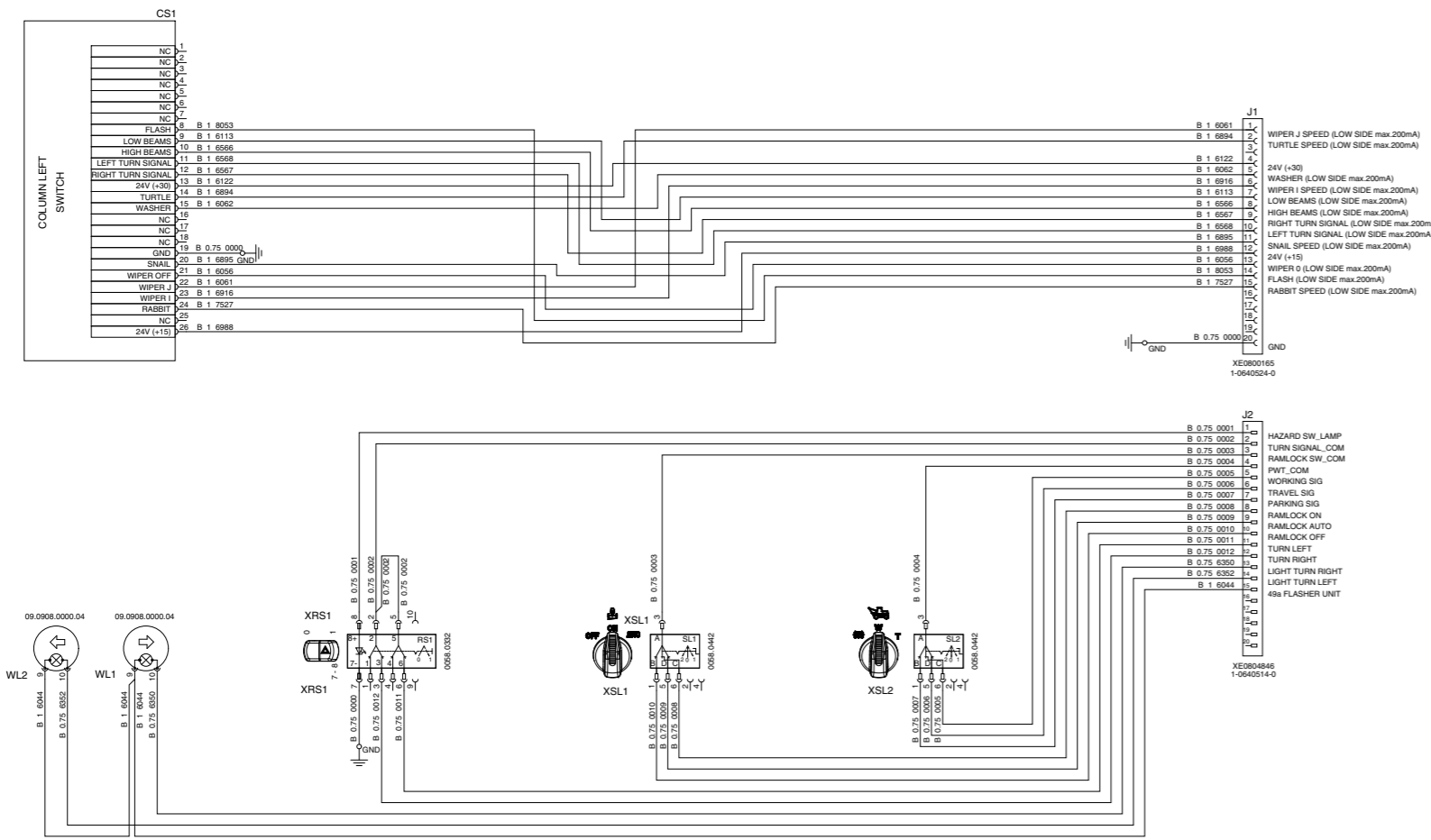

STEERING COLUMN HARNESS

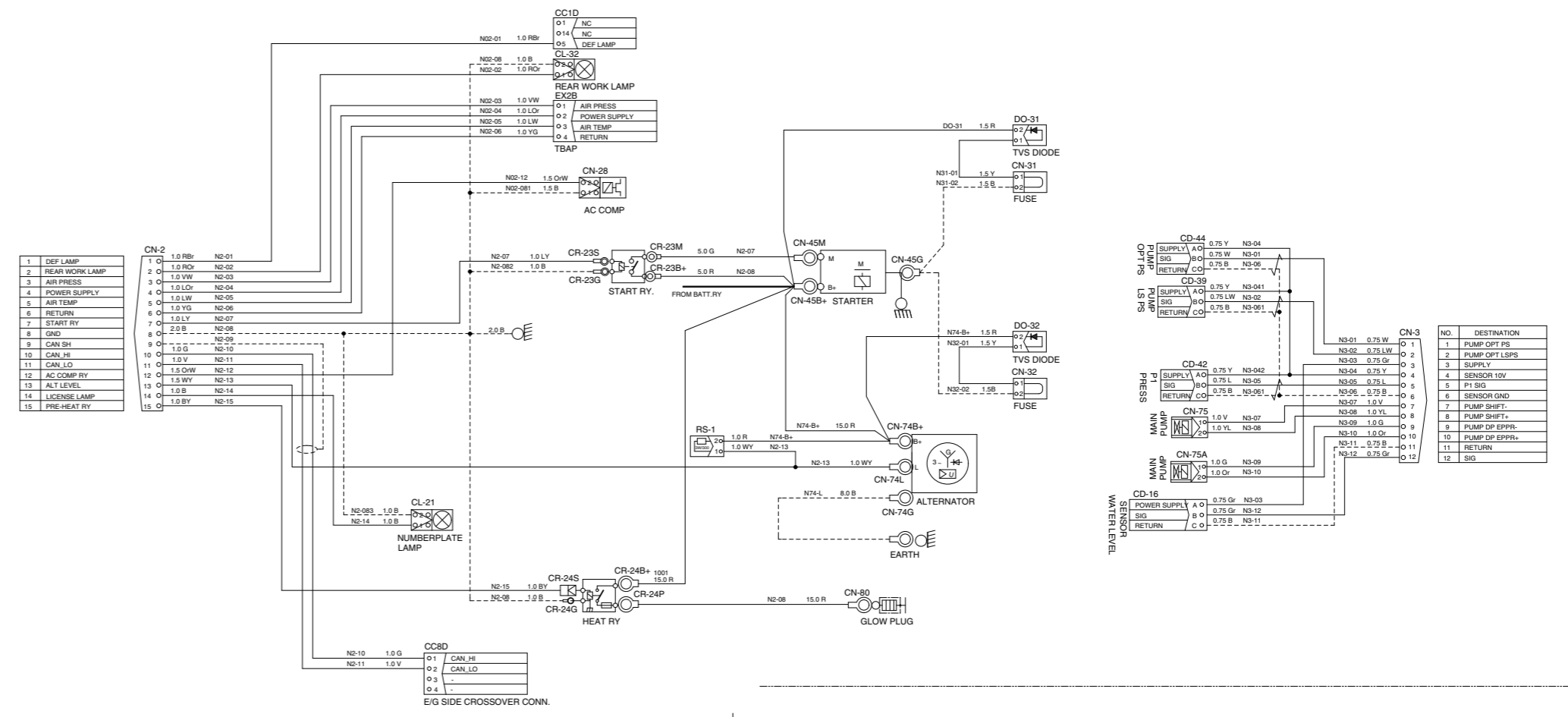

E/G HARNESS

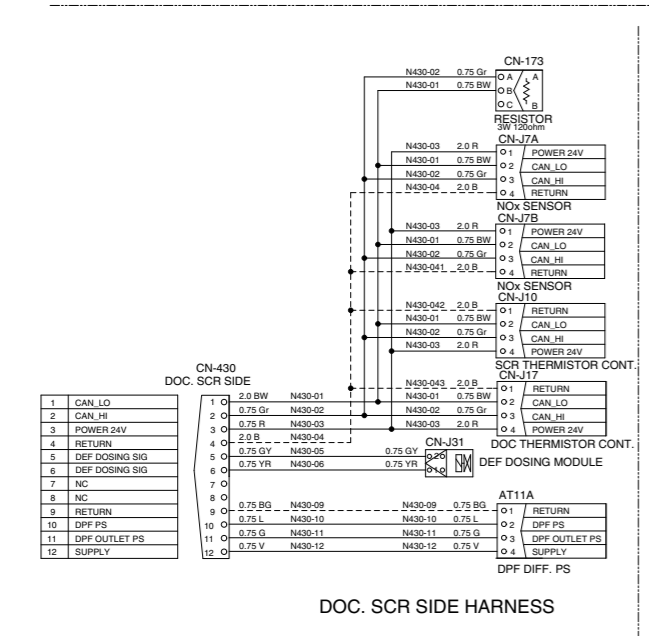

DOC. SCR SIDE HARNESS

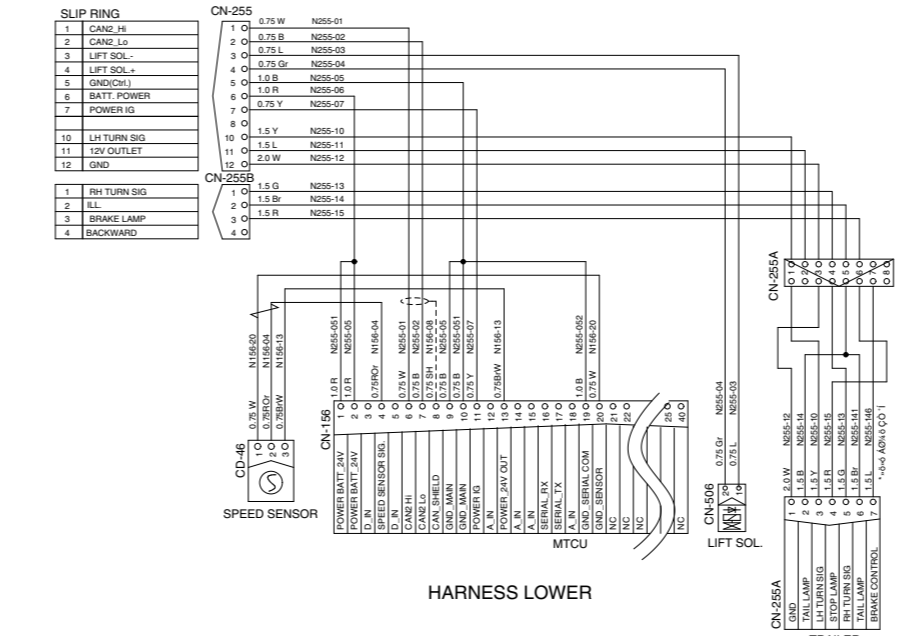
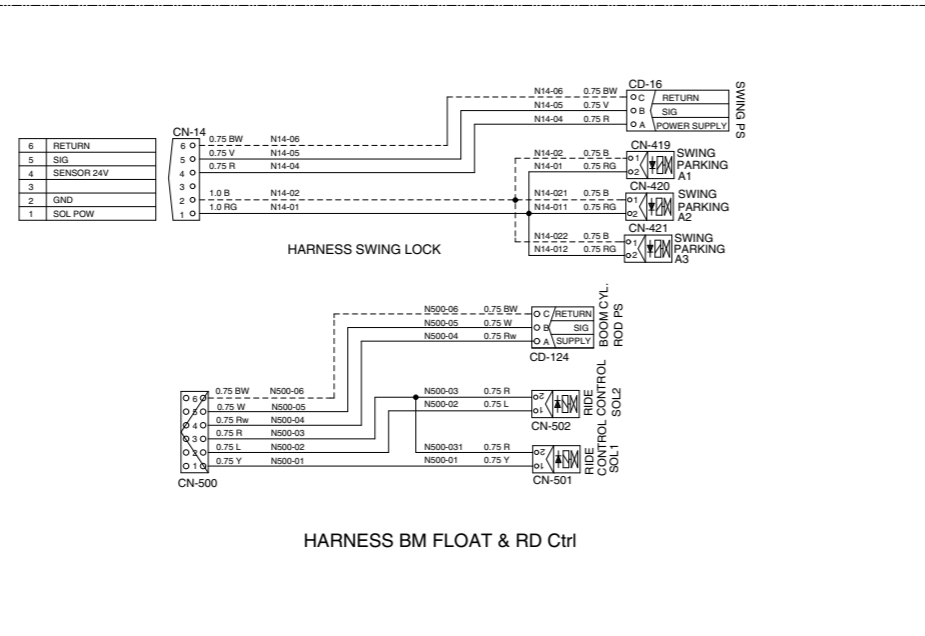

HARNES LOWER

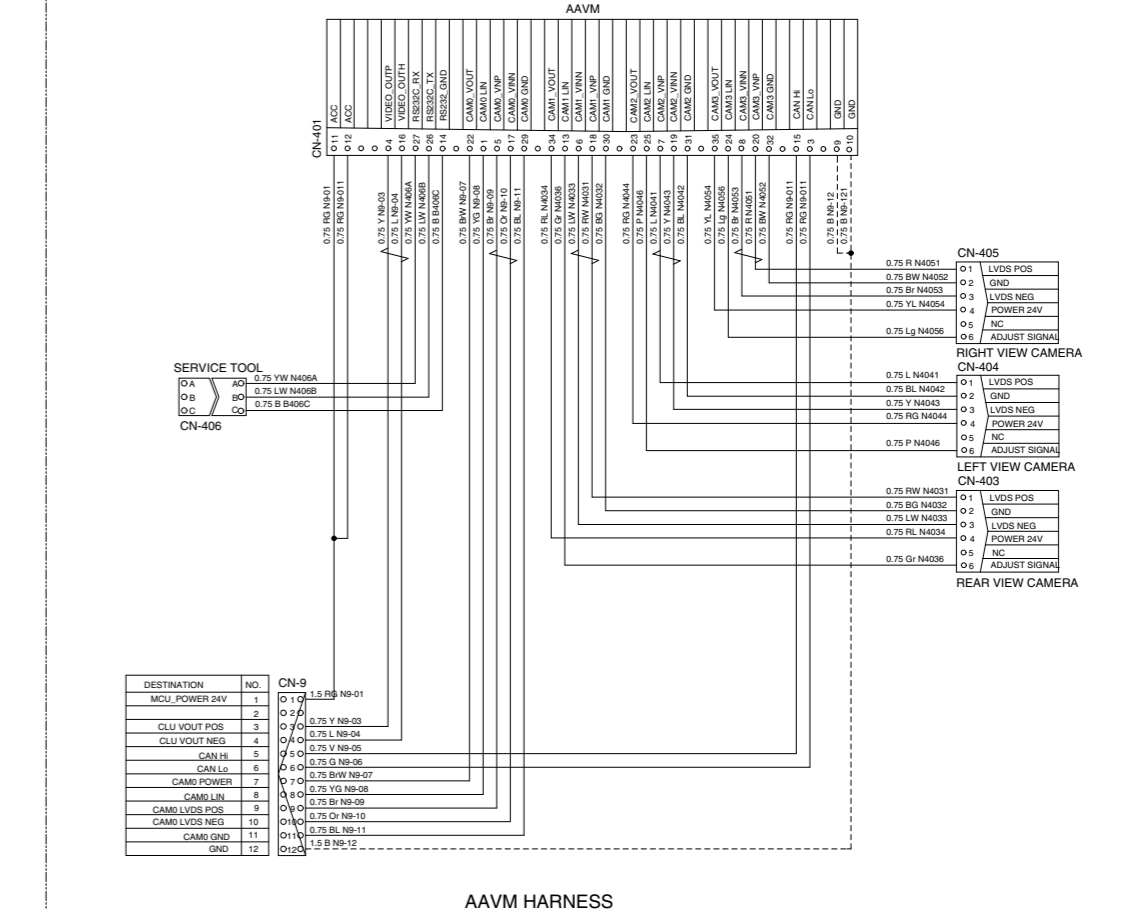

AAMV HARNESS

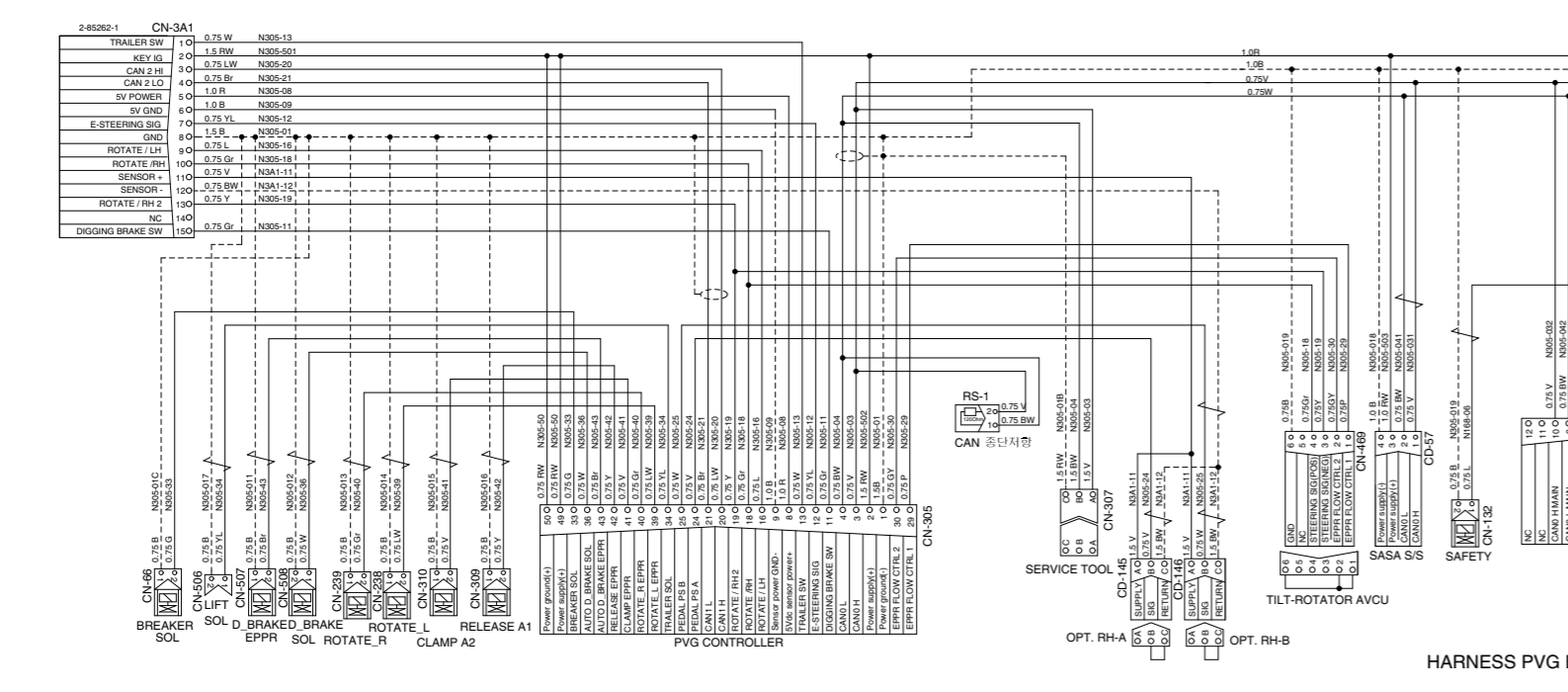

HARNES PVG E/STEERING

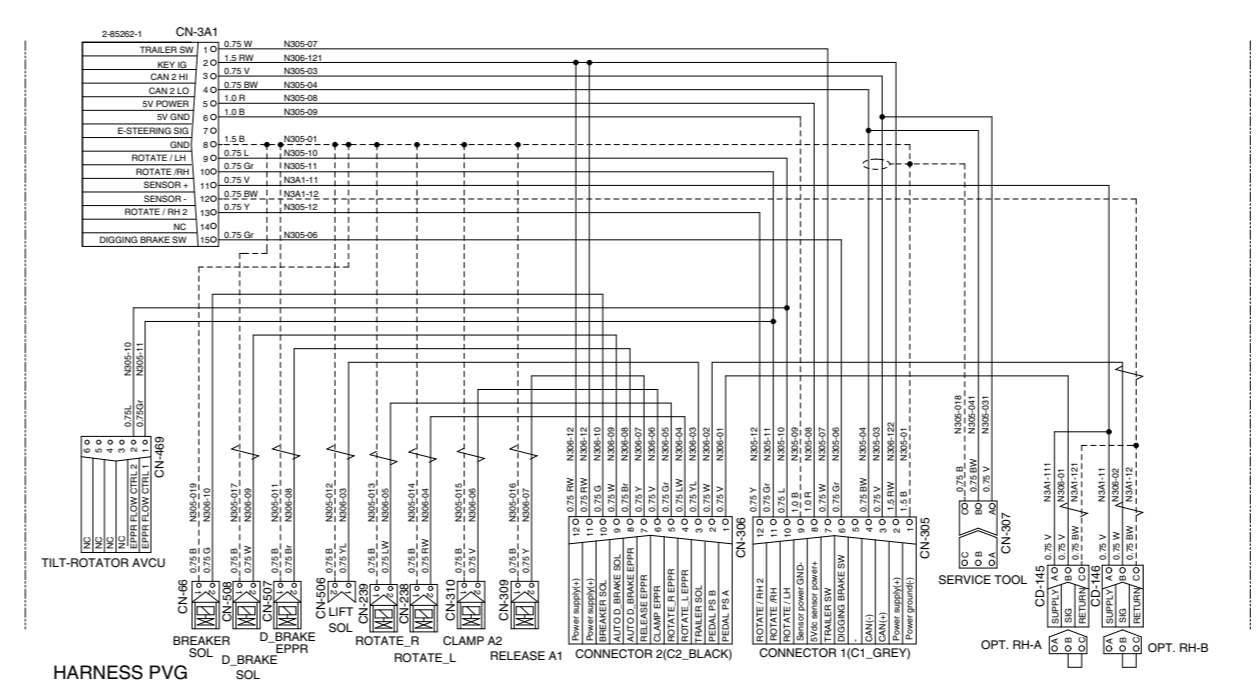

HARNES PVG

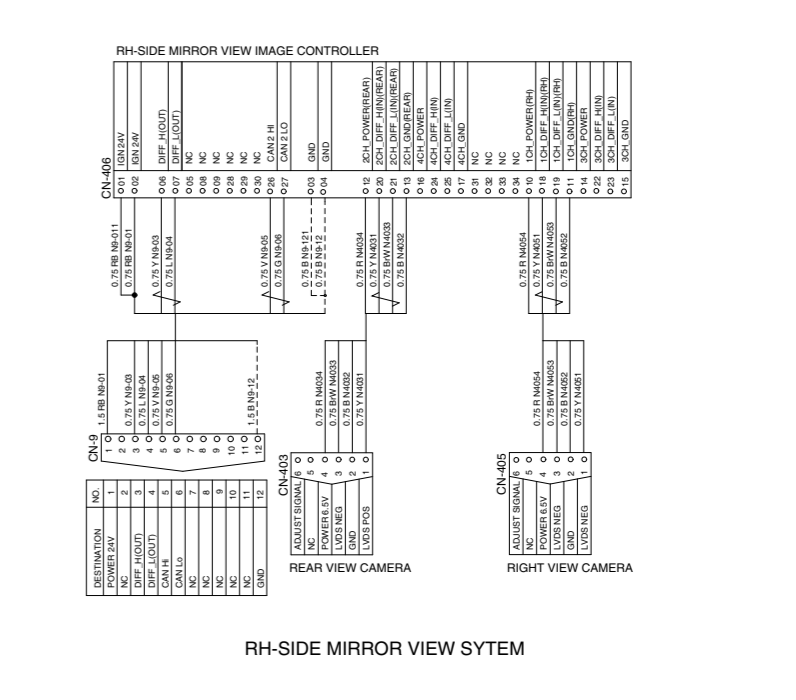

RH-SIDE MIRROR VIEW SYSTEM

MEMORANDUM

1. POWER CIRCUIT

The negative terminal of battery is grounded to the machine chassis directly.

When the start switch is in the OFF position, the current flows from the positive battery terminal as shown below.

1) OPERATING FLOW

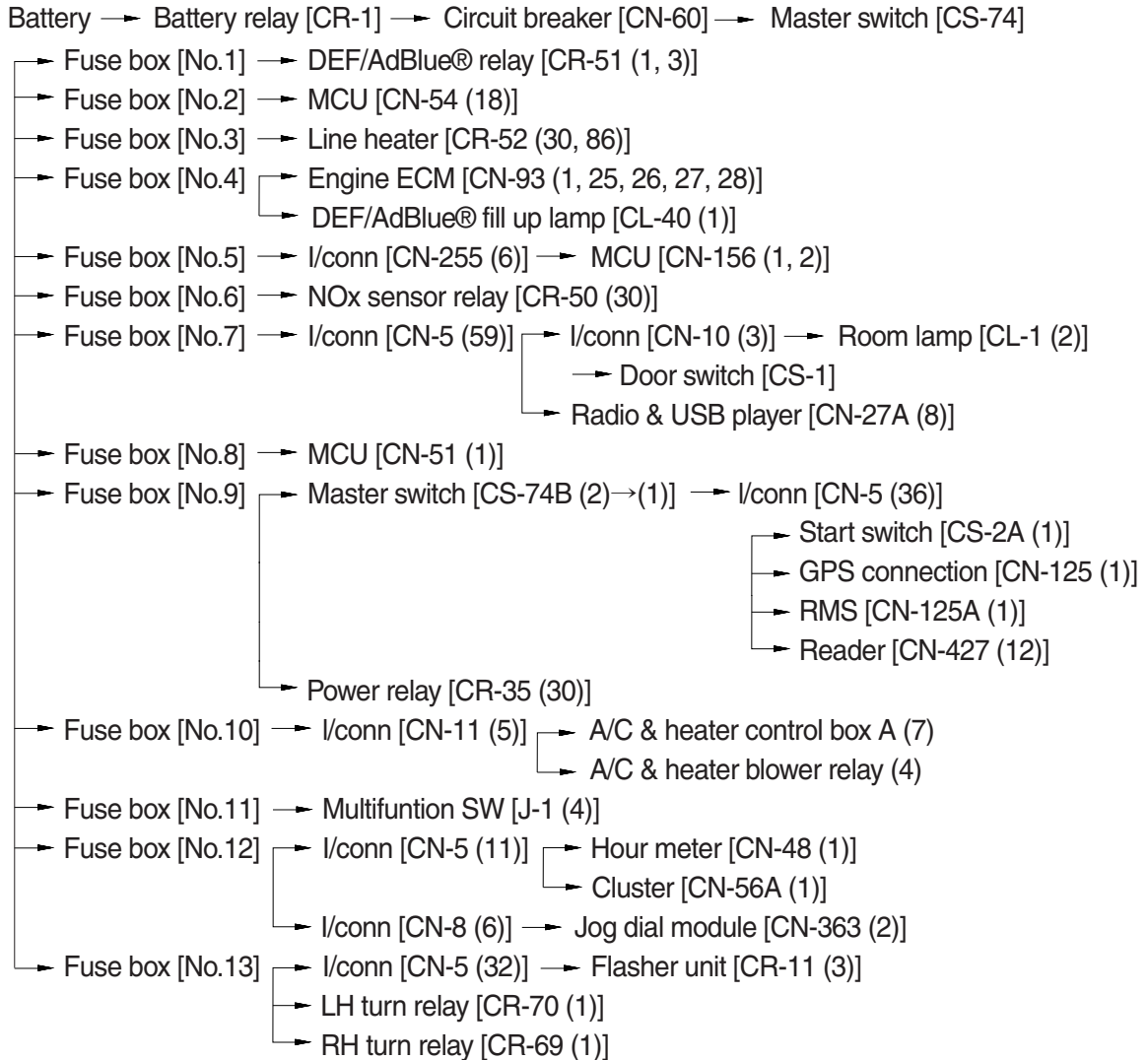

I/conn : Intermediate connector

2) CHECK POINT

Engine	Start switch	Check point	Voltage
STOP	OFF	① - GND (battery 1EA)	10~12.5 V
		② - GND (battery 2EA)	20~25 V
		③ - GND (battery relay 2EA)	20~25 V
		④ - GND (circuit breaker)	20~25 V

※ GND : Ground

POWER CIRCUIT

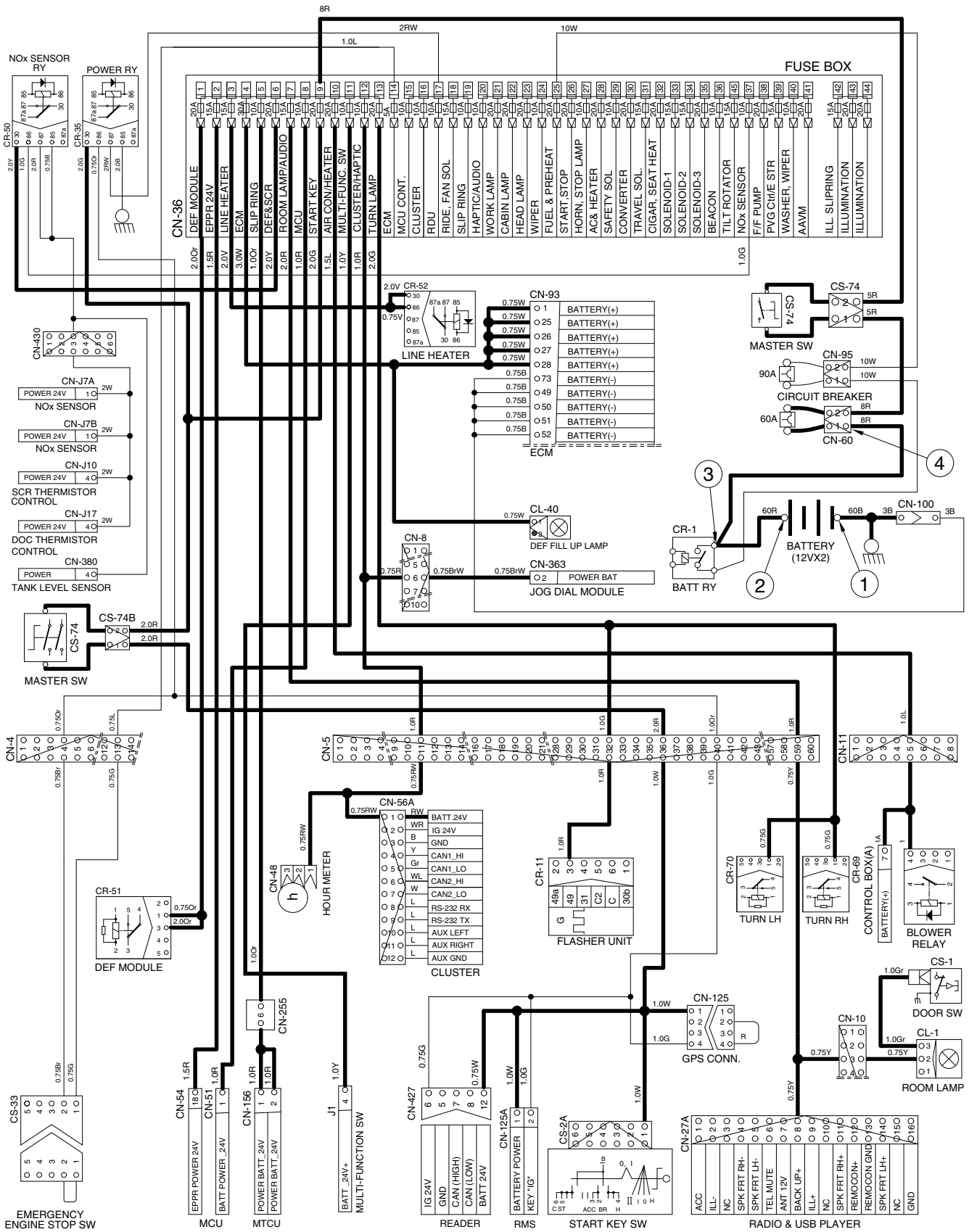

150WA4EL03

2. STARTING CIRCUIT

1) OPERATING FLOW

Battery (+) terminal → Battery relay [CR-1] → Circuit breaker [CN-60] → Master switch [CS-74]
 → Fuse box [No.9] → Master switch [CS-74B] → I/conn [CN-5 (36)] → Start switch [CS-2A (1)]
 → Power relay [CR-35 (30)]

(1) When start key switch is in ON position

→ Start switch ON [CS-2A (2)] → I/conn [CN-5 (39)] → Battery relay [CR-1]
 → Battery relay operating (all power is supplied with the electric component)
 → Start switch ON [CS-2A (3)] → GPS conn [CN-125 (2)→(4)] → RMS [CN-125A (2)]
 → Reader [CN-427 (6)]
 → I/conn [CN-5 (40)]

→ Power relay [CR-35 (86) → (87)] → Fuse box [No.15]
 → MCU [CN-51 (26)]

→ I/conn [CN-4 (4)] → Emergency engine stop sw [CS-33 (2) → (1)]
 → I/conn [CN-4 (13)] → Fuse box [No. 14] → ECM [CN-93 (5)]

(2) When start key switch is in START position

Start switch START [CS-2A (6)] → I/conn [CN-5 (35)] → Anti-restart relay [CR-5 (1) → (5)]
 → I/conn [CN-2 (7)] → Start relay [CR-23 (S)] → Starter motor operating

2) CHECK POINT

Engine	Start switch	Check point	Voltage
OPERATING	START	① - GND (battery) ② - GND (start key) ③ - GND (battery relay M4) ④ - GND (starter B ⁺) ⑤ - GND (starter M) ⑥ - GND (start relay G) ⑦ - GND (battery relay M8)	20~25V

STARTING CIRCUIT

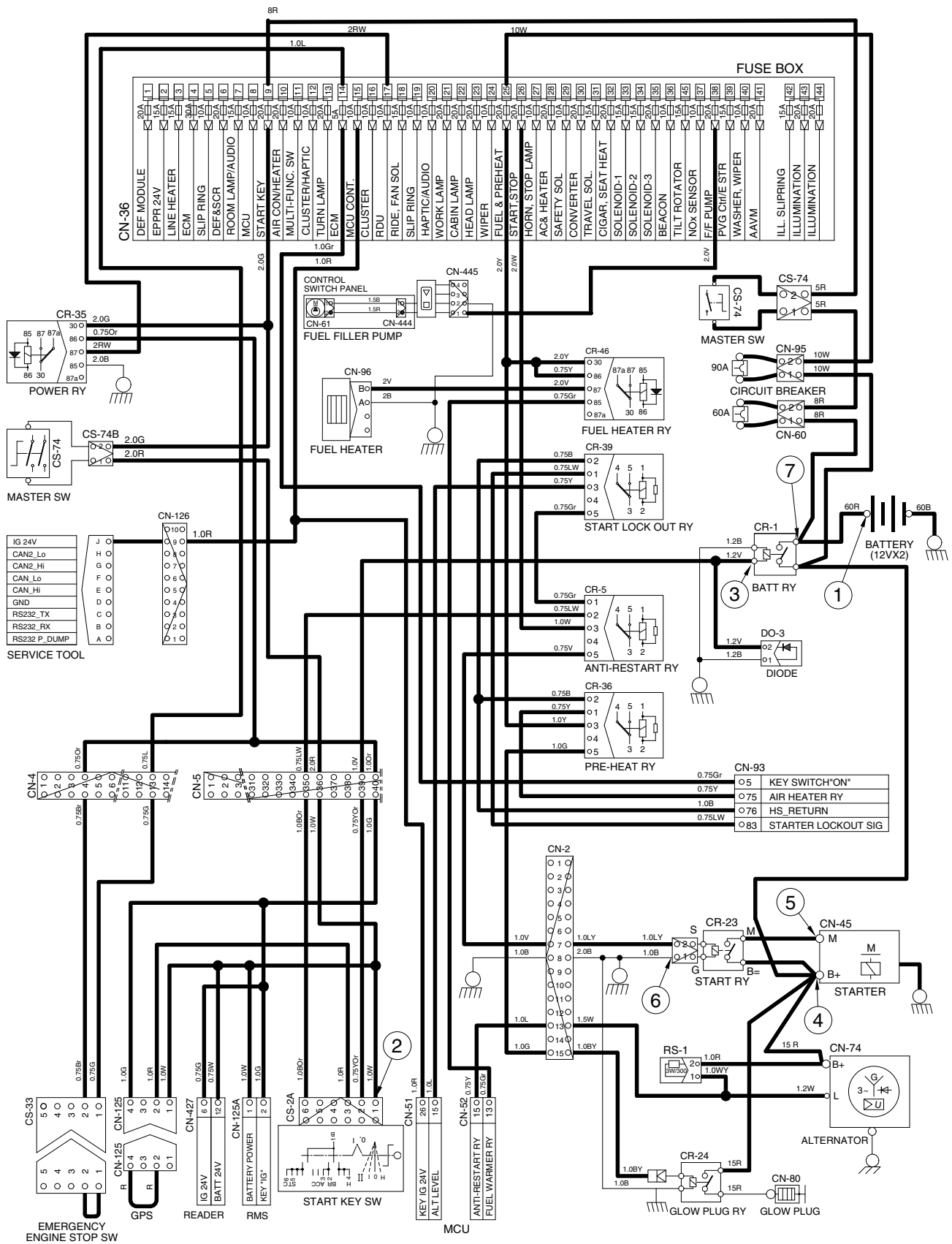

150WA4EL04

3. CHARGING CIRCUIT

When the starter is activated and the engine is started, the operator releases the start switch to the ON position.

Charging current generated by operating alternator flows into the battery through the battery relay [CR-1].

The current also flows from alternator to each electrical component and controller through the fuse box.

1) OPERATING FLOW

(1) Warning flow

Alternator [CN-74 (L)] → I/conn [CN-2 (13)] → MCU alternator level [CN-51 (15)] → Cluster charging warning lamp (via CAN interface)

(2) Charging flow

Alternator [CN-74 (B⁺)] → Starter [CN-45 (B⁺)] → Battery relay (M8)

- Battery (+) terminal
- Circuit breaker [CN-60] → Master switch [CS-74] → Fuse box [No. 1~13]
- Circuit breaker [CN-95] → Fuse box [No. 20~41, 45]

2) CHECK POINT

Engine	Start switch	Check point	Voltage
Run	ON	① - GND (battery voltage) ② - GND (battery relay) ③ - GND (alternator B ⁺ terminal) ④ - GND (alternator L terminal) ⑤ - GND (MCU)	20~30 V

※ GND : Ground

CHARGING CIRCUIT

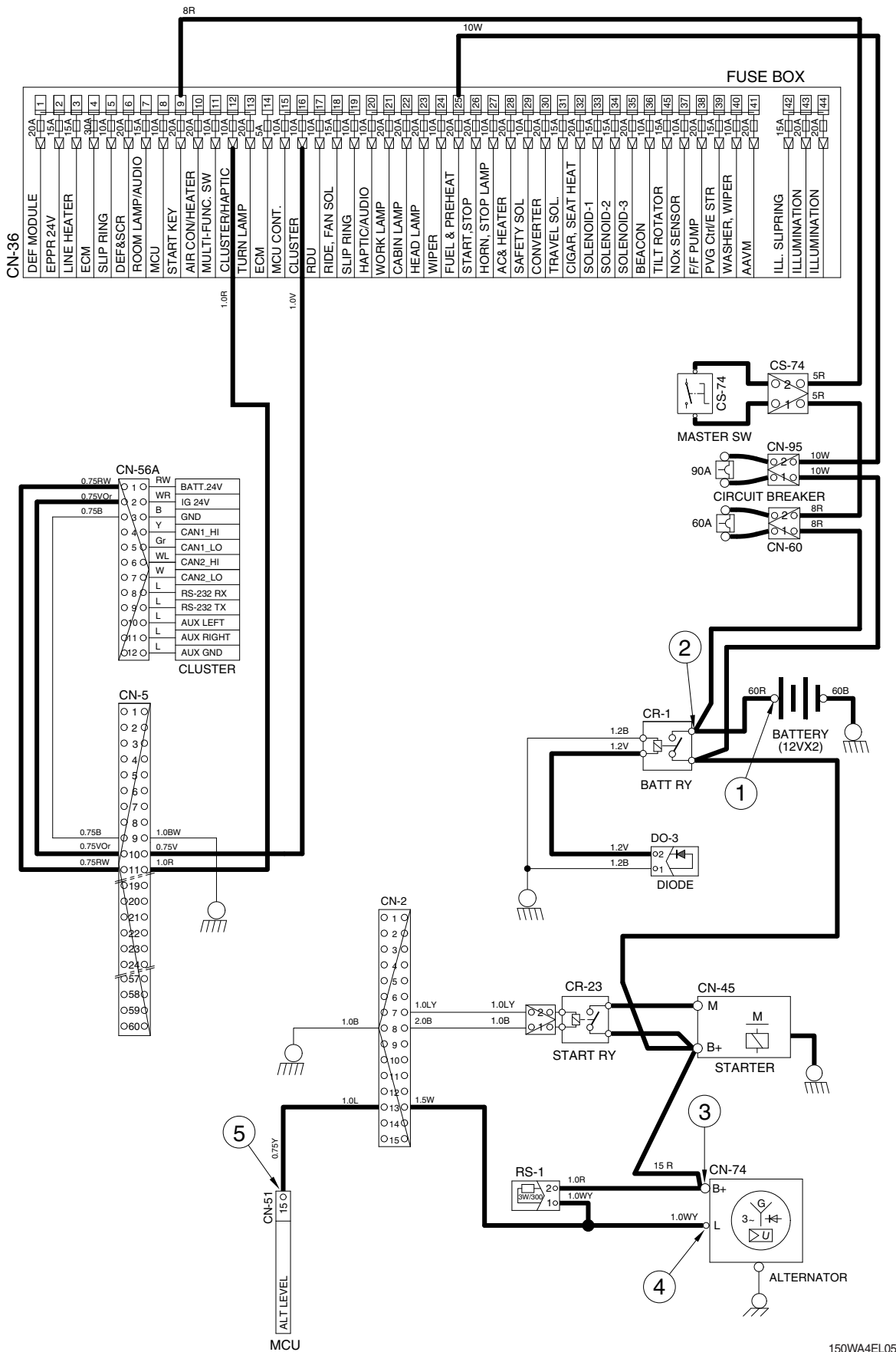

150WA4EL05

4. HEAD AND WORK LIGHT CIRCUIT

1) OPERATING FLOW

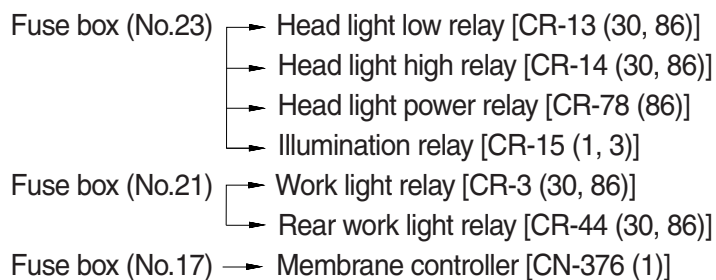

(1) Head light switch ON

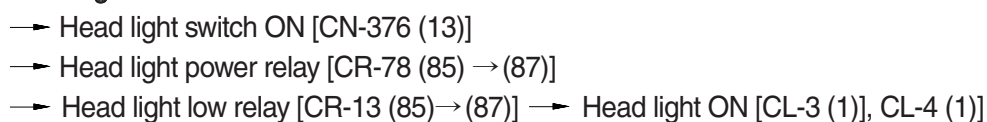

(2) Work light switch ON

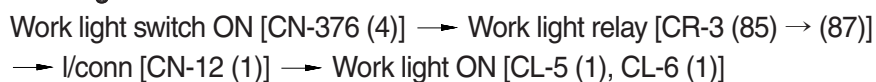

(3) Rear work light switch ON

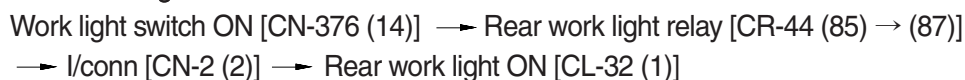

2) CHECK POINT

Engine	Start switch	Check point	Voltage
STOP	ON	① - GND (fuse box) ② - GND (switch power output) ③ - GND (head light relay) ④ - GND (head light) ⑤ - GND (fuse box) ⑥ - GND (switch power output) ⑦ - GND (work light relay) ⑧ - GND (work light) ⑨ - GND (switch power output) ⑩ - GND (rear work light relay) ⑪ - GND (rear work light)	20~30 V

※ GND : Ground

HEAD AND WORK LIGHT CIRCUIT

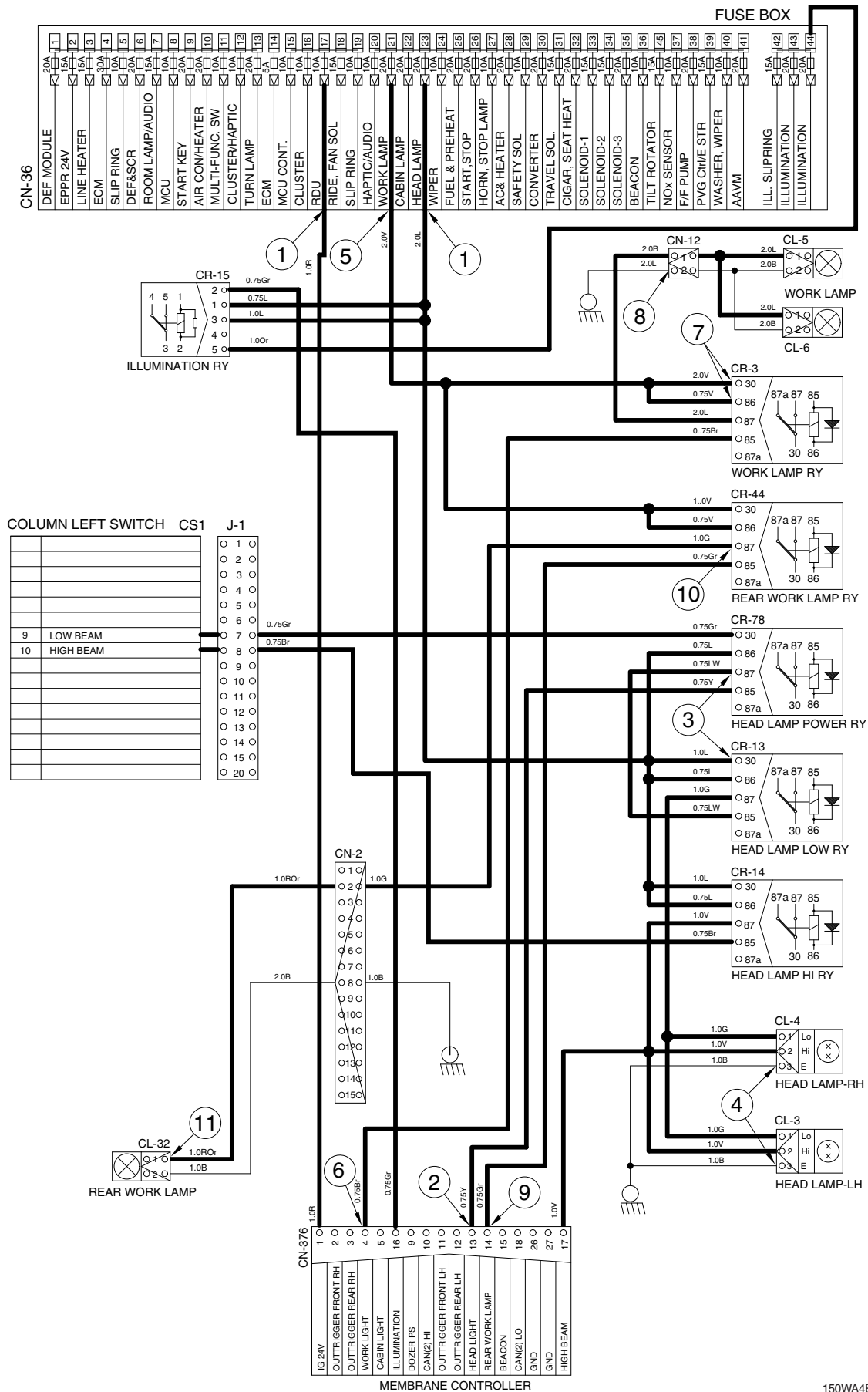

150WA4EL06

5. BEACON LAMP AND CAB LIGHT CIRCUIT

1) OPERATING FLOW

Fuse box (No.36) → Beacon lamp relay [CR-85 (1, 3)]

Fuse box (No.22) → Cab light relay [CR-9 (30, 86)]

Fuse box (No.17) → Membrane controller [CN-376 (1)]

(1) Beacon lamp switch ON

Beacon lamp switch ON [CN-376 (15)] → Beacon light relay [CR-85 (2) → (5)]

→ I/conn [CN-5 (50)] → I/conn [CN-10 (10)] → Beacon lamp ON [CL-7]

(2) Cab light switch ON

Cab light switch ON [CN-376 (5)] → Cab lamp relay [CR-9 (85) → (87)]

→ I/conn [CN-5 (34, 38)] → I/conn [CN-10 (11)] → Cab light ON [CL-8 (2)]

→ I/conn [CN-10 (12)] → Cab light ON [CL-9 (2), CL-10 (2)]

2) CHECK POINT

Engine	Start switch	Check point	Voltage
STOP	ON	① - GND (fuse box) ② - GND (beacon lamp relay) ③ - GND (switch power output) ④ - GND (beacon lamp) ⑤ - GND (fuse box) ⑥ - GND (cab light relay) ⑦ - GND (switch power output) ⑧ - GND (cab light)	20~25 V

※ GND : Ground

BEACON LAMP AND CAB LIGHT CIRCUIT

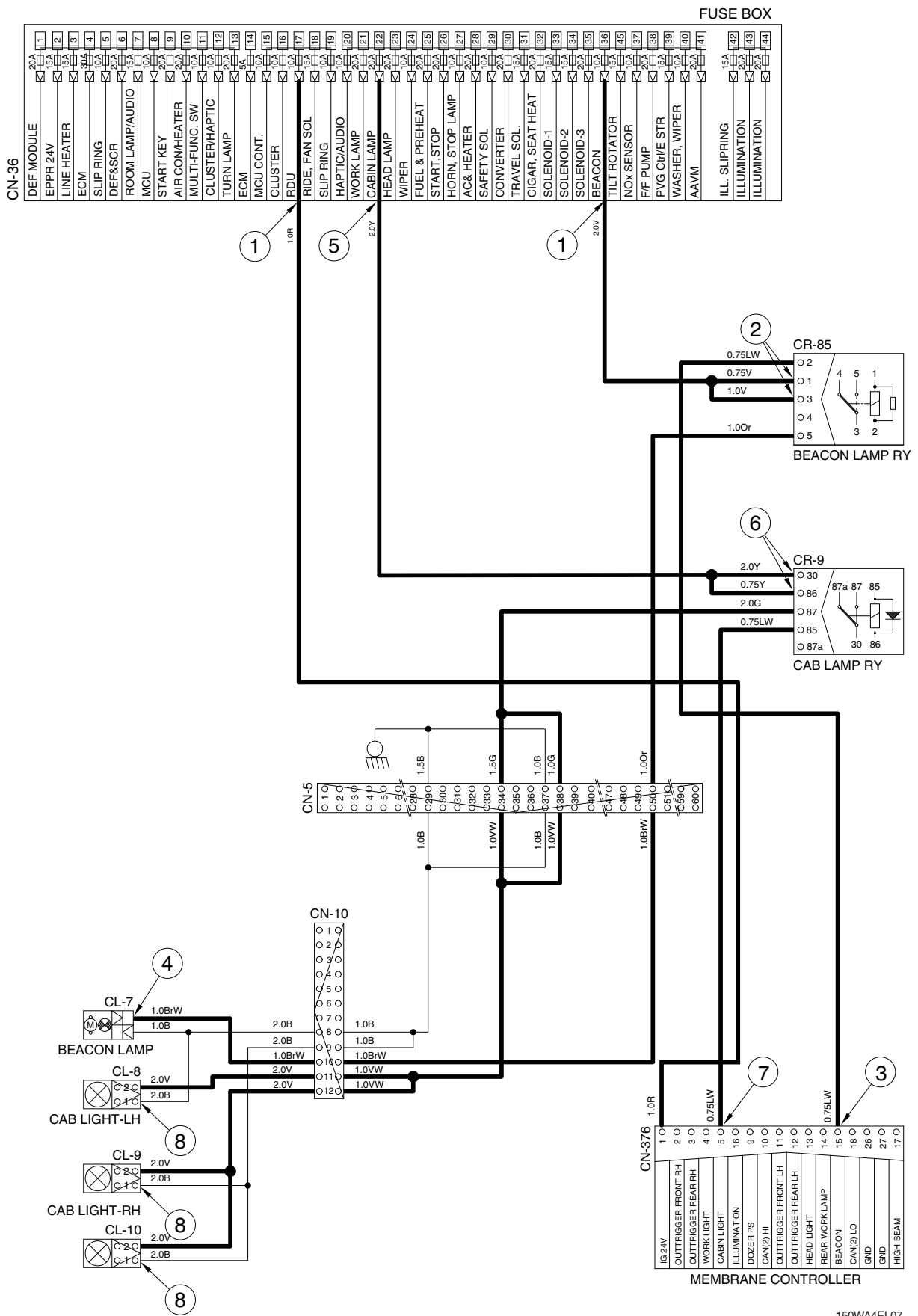

150W4EL07

6. WIPER AND WASHER CIRCUIT

1) OPERATING FLOW

(1) Key switch ON

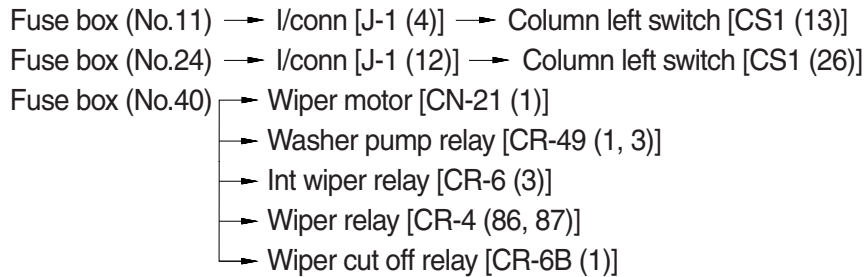

(2) Wiper switch ON : 1st step

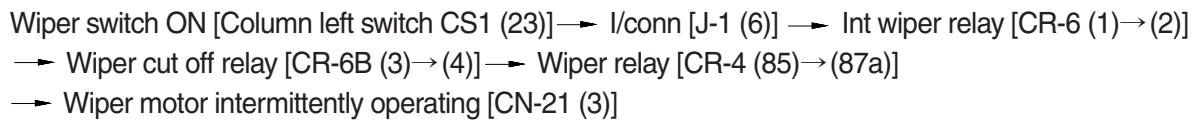

(3) Wiper switch ON : 2nd step

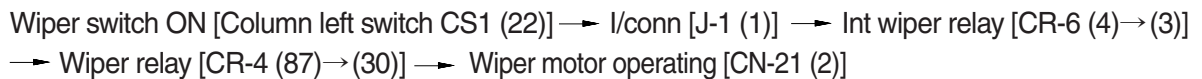

(4) Washer switch ON

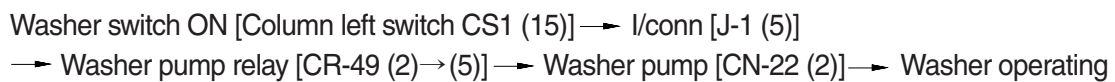

(5) Auto parking (when switch OFF)

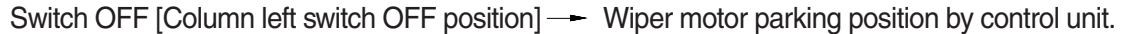

2) CHECK POINT

Engine	Start switch	Check point	Voltage
STOP	ON	① - GND (fuse box)	20~25 V
		② - GND (switch power input)	
		③ - GND (switch power output)	0~5 V
		④ - GND (Inter wiper relay input)	
		⑤ - GND (wiper motor)	

※ GND : Ground

WIPER AND WASHER CIRCUIT

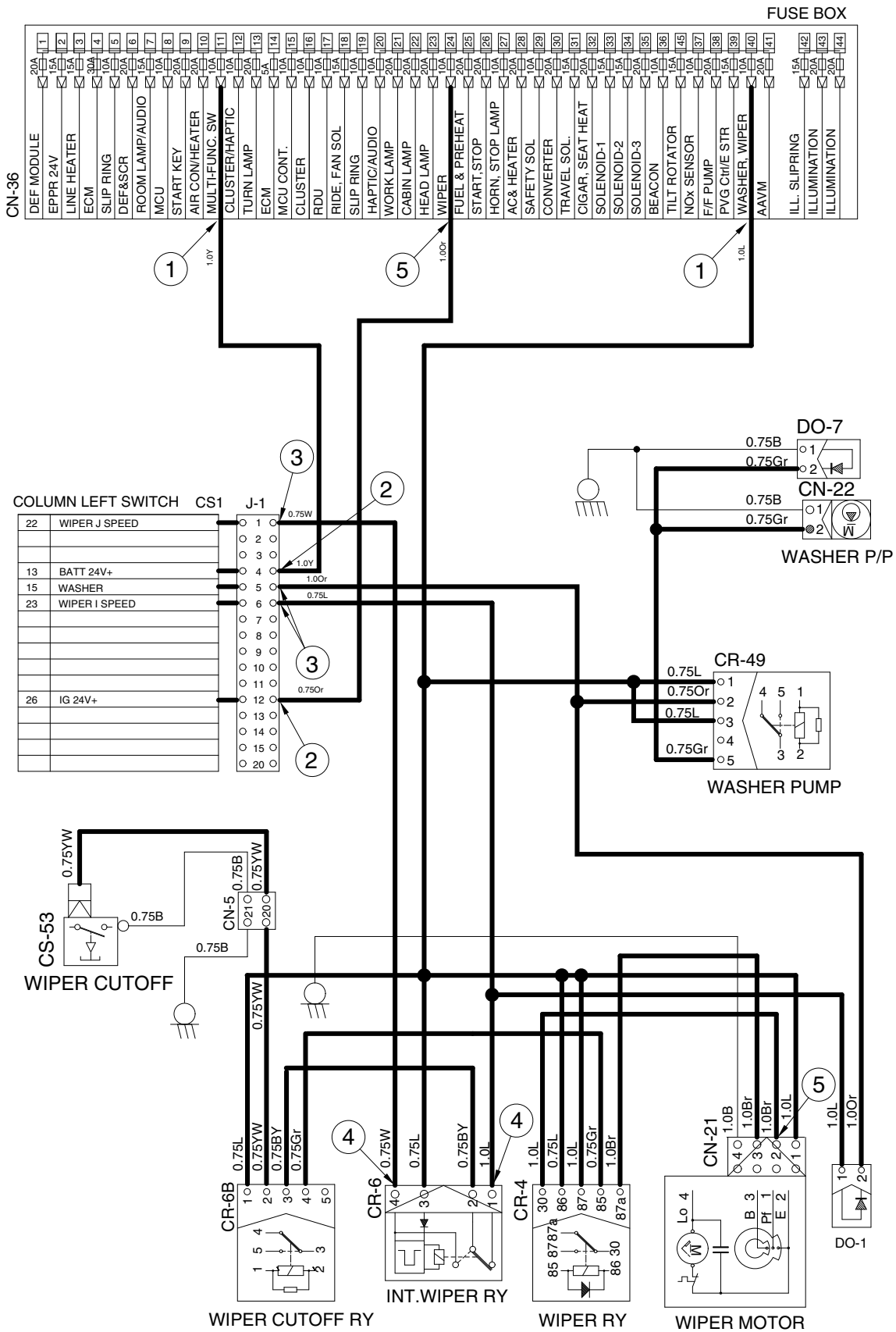

ILLUMINATION CIRCUIT

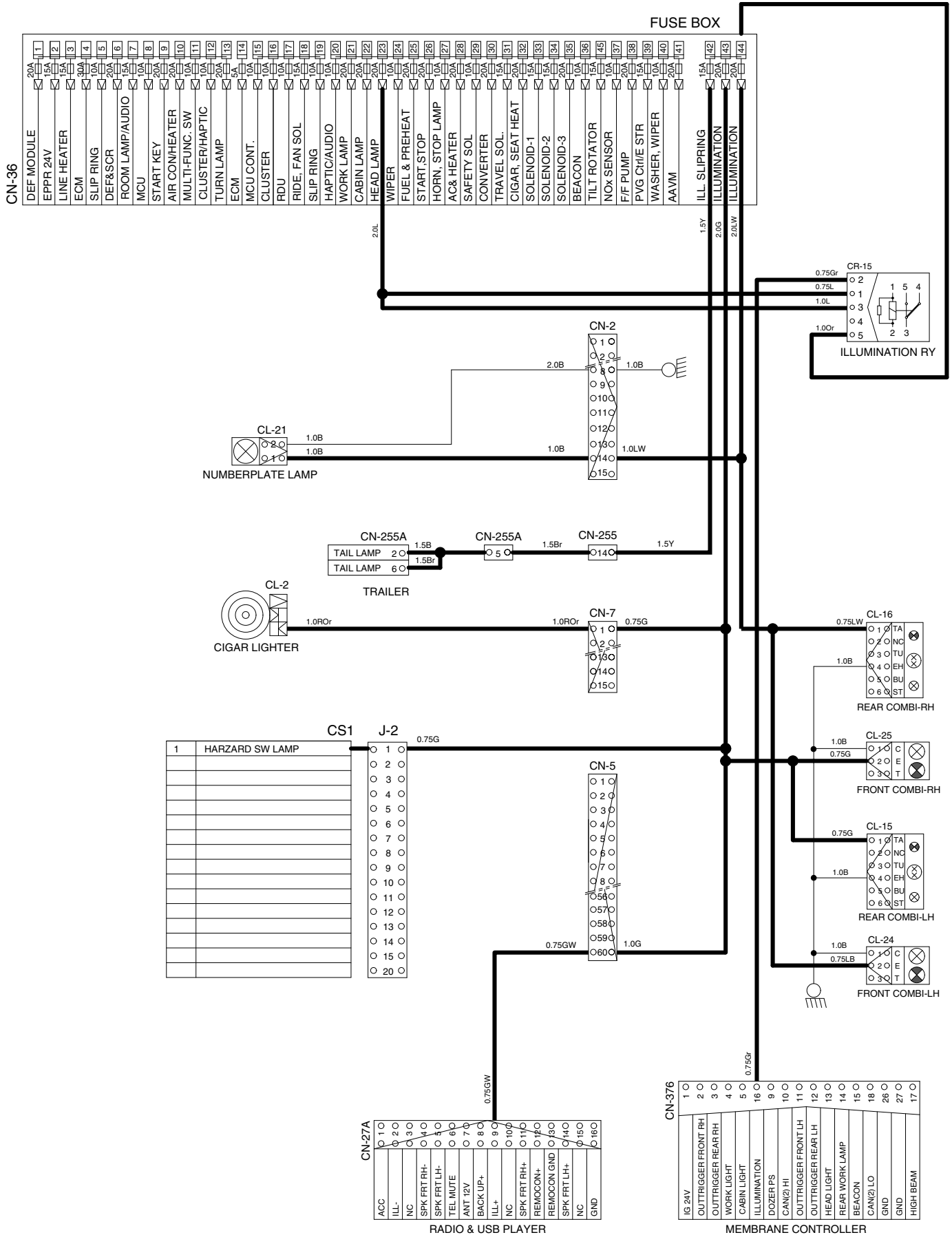

COMBINATION LAMP CIRCUIT

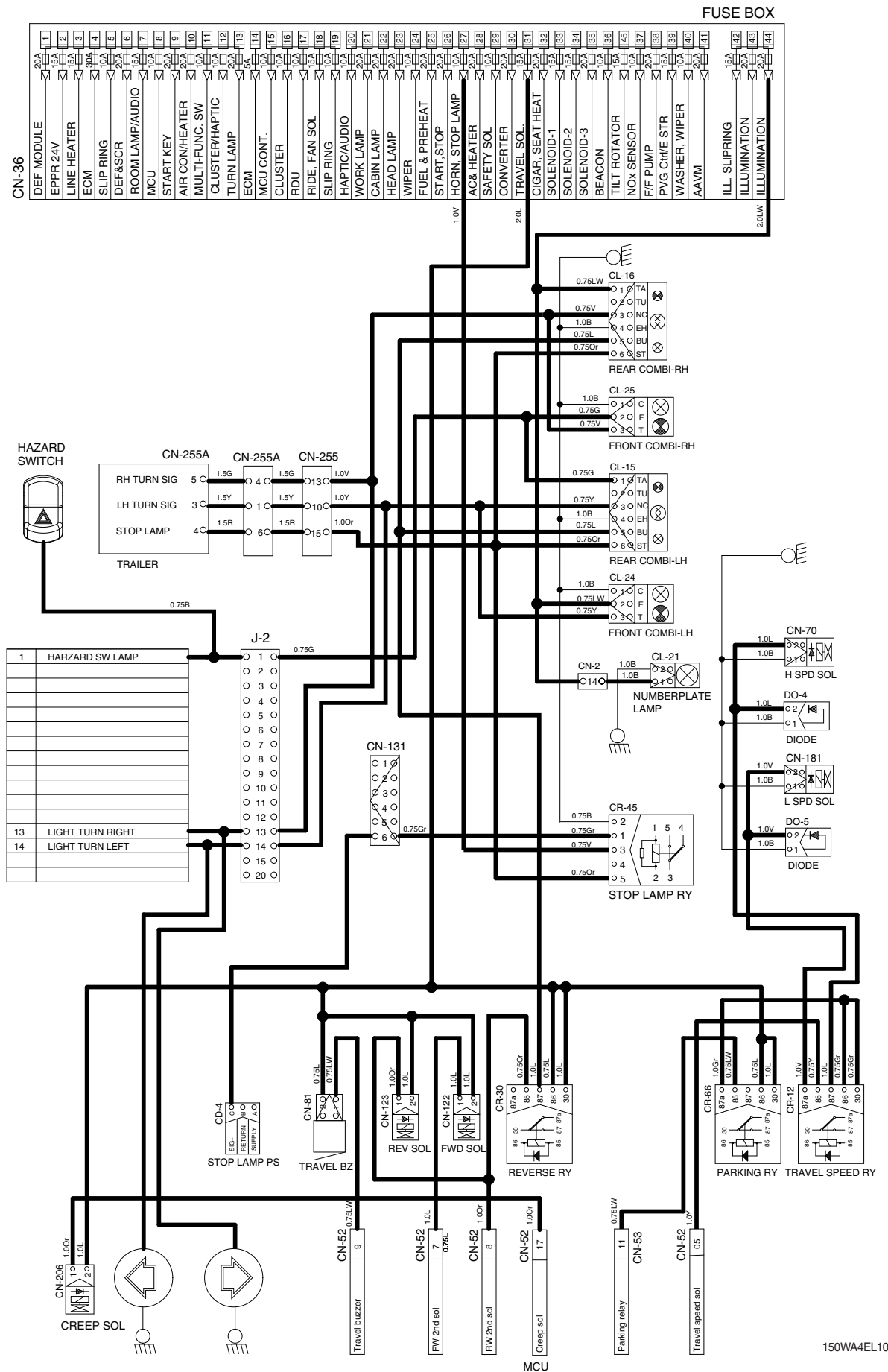

CONTROLLER CIRCUIT

FUSE BOX

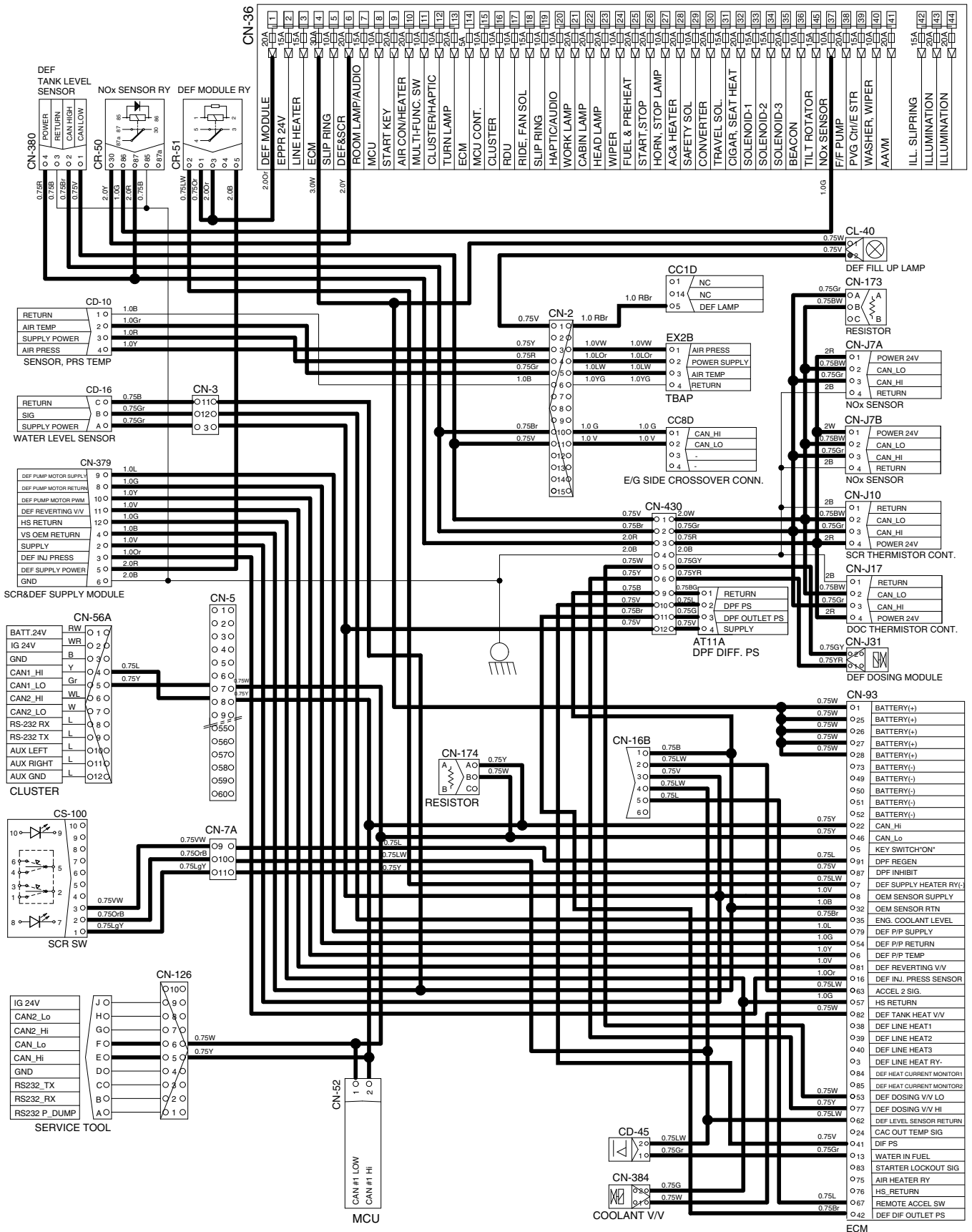

150WA4EL11

MONITORING CIRCUIT

FUSE BOX

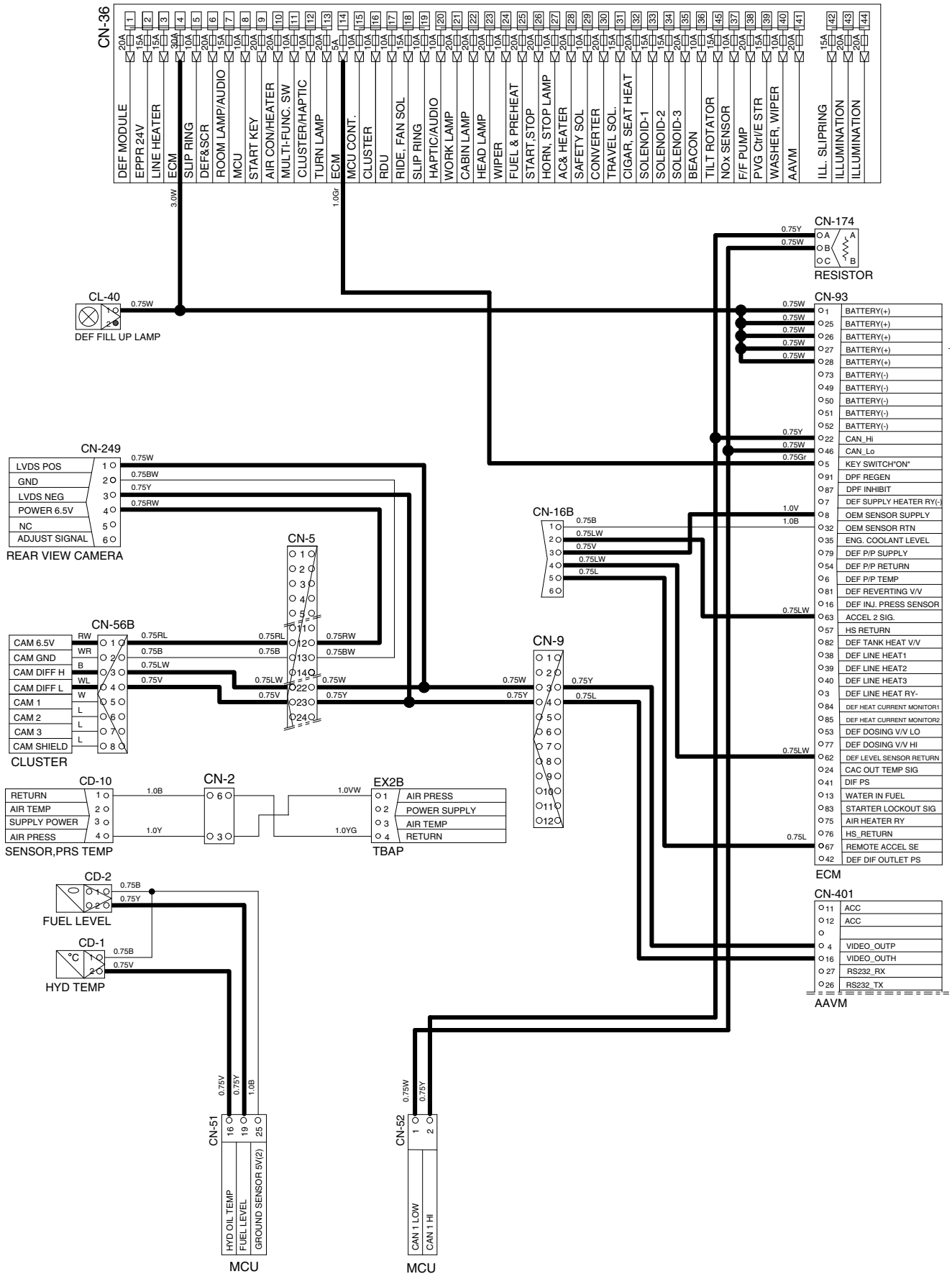

150WA4EL12

ELECTRIC CIRCUIT FOR HYDRAULIC (1/2)

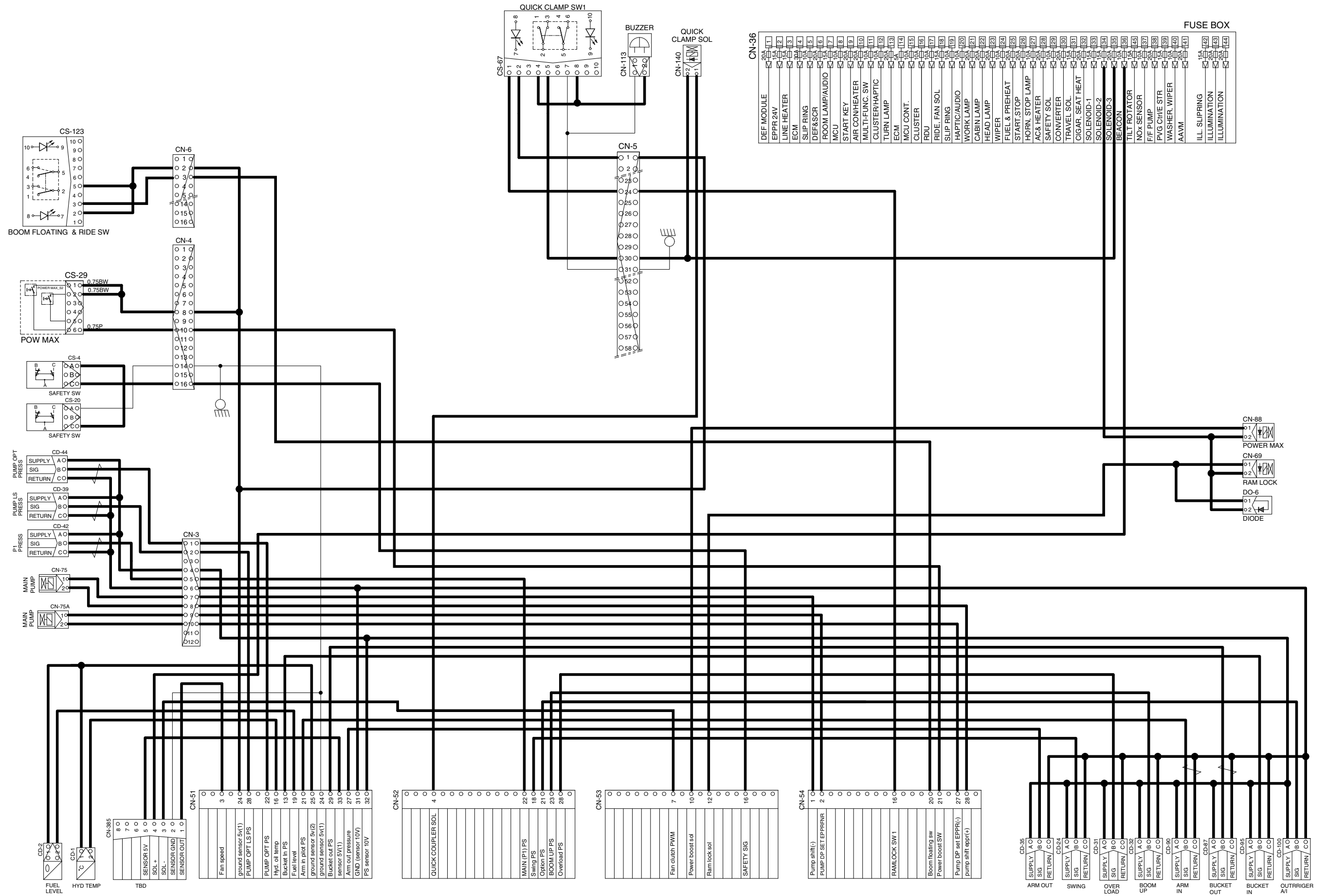

ELECTRIC CIRCUIT FOR HYDRAULIC (2/2)

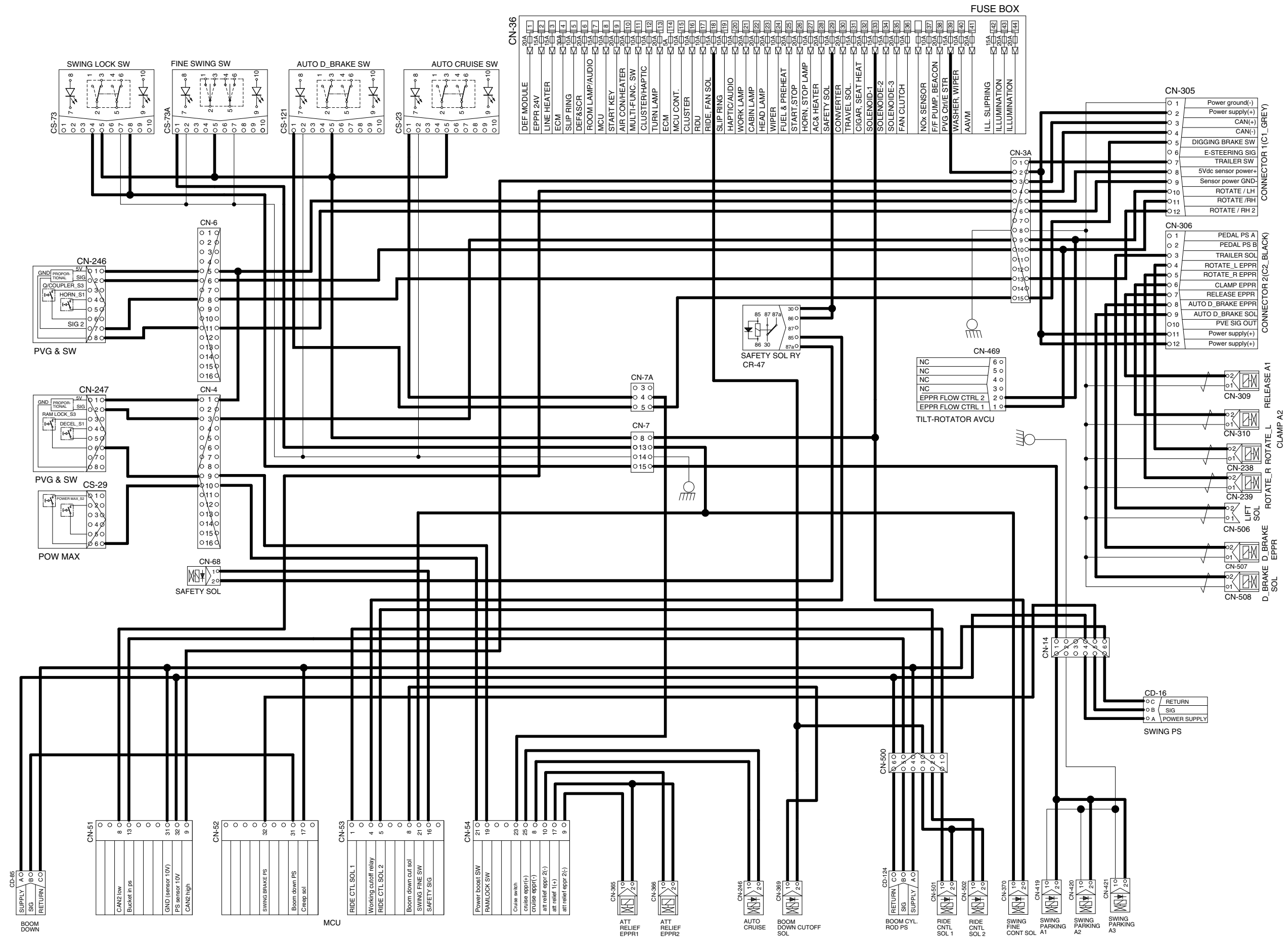

GROUP 3 ELECTRICAL COMPONENT SPECIFICATION

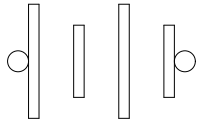
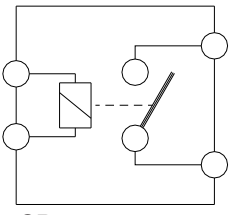
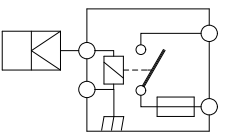
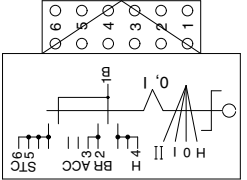

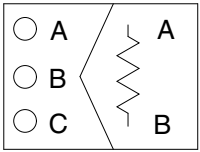
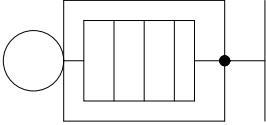
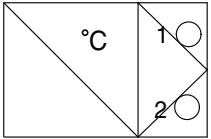
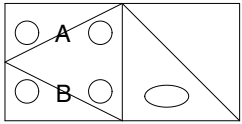
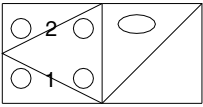
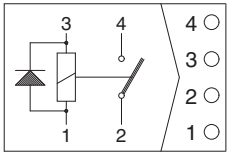
Part name	Symbol	Specifications	Check						
Battery		12V × 100Ah (2EA)	※ Check specific gravity 1.280 over : Over charged 1.280 ~ 1.250 : Normal 1.250 below : Recharging						
Battery relay	 <p style="text-align: center;">CR-1</p>	Rated load : 24V 100A (continuity) 1000A (30 seconds)	※ Check coil resistance(M4 to M4) Normal : About 50Ω ※ Check contact Normal : ∞Ω						
Glow plug relay	 <p style="text-align: center;">CR-24</p>	24V 200A	※ Check contact Normal : 0.942Ω (For terminal 1-GND)						
Start key	 <p style="text-align: center;">CS-2A</p>	B-BR : 24V 1A B-ACC : 24V 10A B-ST : 24V 40A	※ Check contact OFF : ∞Ω (for each terminal) ON : 0Ω (for terminal 1-3 and 1-2) START : 0Ω (for terminal 1-6)						
Pressure sensor	<table border="1" style="margin: auto;"> <tr><td>○ A</td><td>SUPPLY</td></tr> <tr><td>○ B</td><td>SIG</td></tr> <tr><td>○ C</td><td>RETURN</td></tr> </table> <p>CD-3 CD-5 CD-16 CD-24 CD-31 CD-32 CD-35 CD-37 CD-38 CD-39 CD-42 CD-44 CD-71 CD-73 CD-74 CD-85 CD-87 CD-90 CD-95 CD-100 CD-101 CD-102 CD-124 CD-145 CD-146 CD-156</p>	○ A	SUPPLY	○ B	SIG	○ C	RETURN	8~30V	※ Check contact Normal : 0.1Ω
○ A	SUPPLY								
○ B	SIG								
○ C	RETURN								
Stop lamp pressure sensor	<table border="1" style="margin: auto;"> <tr><td>○ A</td><td>SUPPLY</td></tr> <tr><td>○ B</td><td>RETURN</td></tr> <tr><td>○ C</td><td>SIG</td></tr> </table> <p style="text-align: center;">CD-4</p>	○ A	SUPPLY	○ B	RETURN	○ C	SIG	8~30V	※ Check contact Normal : 0.1Ω
○ A	SUPPLY								
○ B	RETURN								
○ C	SIG								

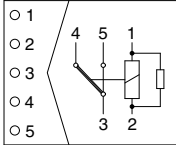
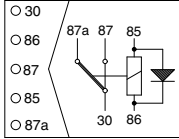
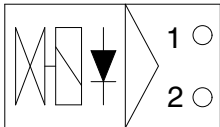
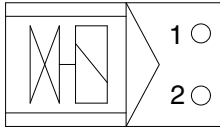
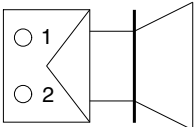
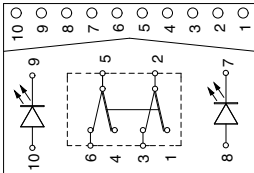
Part name	Symbol	Specifications	Check
Resistor	 CN-173 CN-174	3W	※ Check resistance A-B : 120Ω
Glow plug	 CN-80	24V 200A	※ Check resistance 0.25~0.12Ω
Temperature sensor (hydraulic)	 CD-1	-	※ Check resistance 50°C : 804Ω 80°C : 310Ω 100°C : 180Ω
Fan speed sensor	 CD-52	-	-
Fuel level sender	 CD-2	-	※ Check resistance Full : 50Ω 6/12 : 350Ω 11/12 : 100Ω 5/12 : 400Ω 10/12 : 150Ω 4/12 : 450Ω 9/12 : 200Ω 3/12 : 500Ω 8/12 : 250Ω 2/12 : 550Ω 7/12 : 300Ω 1/12 : 600Ω Empty warning : 700Ω
Relay (air con blower)		24V 16A	※ Check resistance Normal : About 200Ω (for terminal 1-3) 0 Ω (for terminal 2-4)

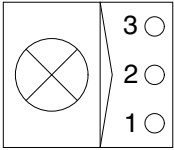
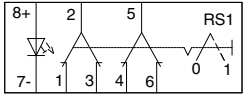
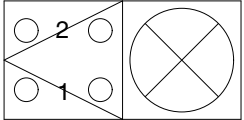
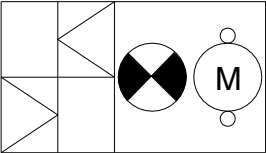
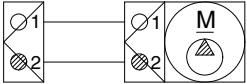
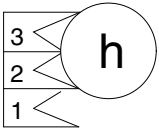
Part name	Symbol	Specifications	Check
Relay	 <p>CR-2 CR-5 CR-6B CR-15 CR-36 CR-39 CR-45 CR-49 CR-51 CR-69 CR-70 CR-81 CR-82 CR-83 CR-84 CR-85</p>	24V 16A	※ Check resistance Normal : About 160 Ω (for terminal 1-2) 0 Ω (for terminal 3-4) ∞ Ω (for terminal 3-5)
Relay	 <p>CR-3 CR-4 CR-7 CR-9 CR-12 CR-13 CR-14 CR-29 CR-30 CR-35 CR-44 CR-46 CR-47 CR-50 CR-52 CR-66 CR-78</p>	24V 16A	※ Check resistance Normal : About 160 Ω (for terminal 85-86) 0 Ω (for terminal 30-87a) ∞ Ω (for terminal 30-87)
Solenoid valve	 <p>CN-66 CN-68 CN-69 CN-70 CN-88 CN-122 CN-123 CN-140 CN-181 CN-197 CN-206 CN-214 CN-216 CN-218 CN-220 CN-370 CN-419 CN-420 CN-421 CN-501 CN-502 CN-506</p>	24V 1A	※ Check resistance Normal : 15~25 Ω (for terminal 1-2)
EPPR valve	 <p>CN-75 CN-75A CN-154 CN-155 CN-238 CN-239 CN-246 CN-309 CN-310 CN-365 CN-366 CN-369 CN-378 CN-503 CN-507 CN-508</p>	700mA	※ Check resistance Normal : 15~25 Ω (for terminal 1-2)
Speaker	 <p>CN-23(LH) CN-23(RH)</p>	20W	※ Check resistance Normal : A few Ω
Switch (locking type)	 <p>CS-23 CS-67 CS-73 CS-73A CS-121 CS-125</p>	24V 1.5A	※ Check contact Normal ON : 0 Ω (for terminal 2-3, 5-6) ∞ Ω (for terminal 1-2, 4-5) OFF : ∞ Ω (for terminal 2-3, 5-6) 0 Ω (for terminal 1-2, 4-5)

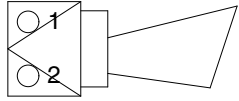
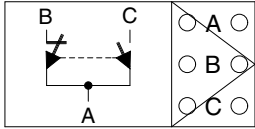
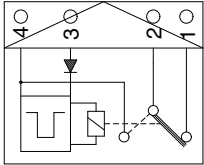
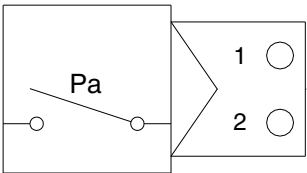
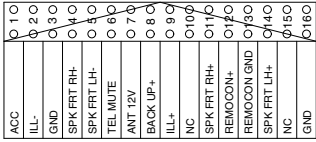
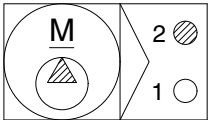
Part name	Symbol	Specifications	Check
Room lamp	 <p>CL-1</p>	24V 10W	※ Check disconnection Normal : 1.0Ω ON : 0Ω (For terminal 1-2) ∞Ω (For terminal 1-3) OFF : ∞Ω (For terminal 1-2) 0Ω (For terminal 1-3)
Hazard switch		24V 1.5A	※ Check contact Normal ON : 0Ω (For terminal 2-3, 5-6) OFF : ∞Ω (For terminal 2-3, 5-6)
Work lamp, Cab lamp, Number plate lamp	 <p>CL-5 CL-6 CL-8 CL-9 CL-10 CL-21 CL-32</p>	24V 65W (H3 Type)	※ Check disconnection Normal : 1.2Ω
Beacon lamp	 <p>CL-7</p>	21V 70W (H1 Type)	※ Check disconnection Normal : A fewΩ
Fuel filler pump		24V 10A 35 l /min	※ Check resistance Normal : 1.0Ω
Hour meter	 <p>CN-48</p>	16~32V	※ Check operation Supply power(24V) to terminal No.2 and connect terminal No.1 and ground

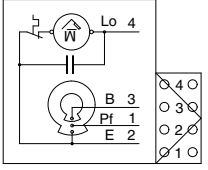
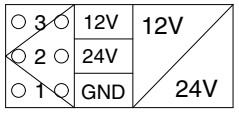
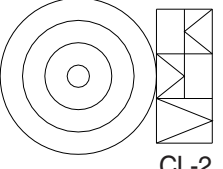
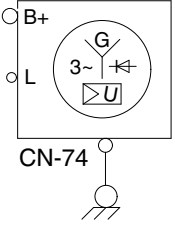
Part name	Symbol	Specifications	Check
Horn	 CN-20 CN-25	DC22~28V 2A	※ Check operation Supply power (24V) to each terminal and connect ground.
Safety switch	 CS-4 CS-20	24V 15A (N.C TYPE)	※ Check contact Normal : 1.0Ω ON : 0Ω (for terminal A-B) ∞Ω (for terminal A-C) OFF : ∞Ω (for terminal A-B) 0Ω (for terminal A-C)
Int wiper relay	 CR-6	-	-
Receiver dryer	 CN-29	24V 2.5A	※ Check contact Normal : ∞Ω
Radio & USB player	 CN-27A	24V 2A	※ Check voltage 20~25V (for terminal 1-3, 3-8)
Washer pump	 CN-22	24V 3.8A	※ Check contact Normal : 10.7Ω (for terminal 1-2)

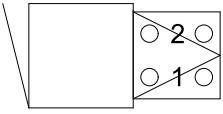
Part name	Symbol	Specifications	Check
Wiper motor	 <p>CN-21</p>	24V 2A	※ Check disconnection Normal : 7Ω (for terminal 2-4)
DC/DC converter	 <p>CN-138</p>	12V 3A	※ Check voltage 24V (for terminal 1-2) 12V (for terminal 1-3)
Cigar lighter	 <p>CL-2</p>	24V 5A 1.4W	※ Check coil resistance Normal : About 1MΩ ※ Check contact Normal : ∞Ω Operating time : 5~15sec
Alternator	 <p>CN-74</p>	24V 95A	※ Check contact Normal : 0Ω (for terminal B ⁺ -L) Normal : 24~27.5V
Starter	 <p>CN-45</p>	24V 4.8kW	※ Check contact Normal : 0.1Ω
Travel alarm	 <p>CN-81</p>	24V 0.5A	※ Check contact Normal : 5.2Ω

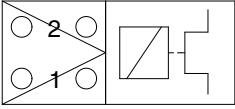
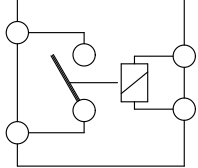
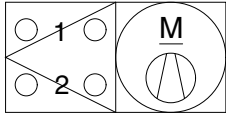
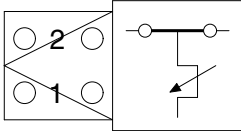
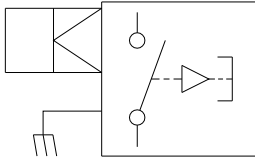
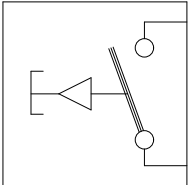
Part name	Symbol	Specifications	Check
Air conditioner compressor	 <p>CN-28</p>	24V 79W	※ Check contact Normal : 13.4Ω
Start relay	 <p>CR-23</p>	24V 300A	※ Check contact Normal : 0.94Ω (for terminal 1-2)
Blower motor		24V 9.5A	※ Check resistance Normal : 2.5Ω (for terminal 1-2)
Duct sensor (switch)		1°C OFF 4°C ON	※ Check resistance Normal : 0Ω (for terminal 1-2), the atmosphere temp : Over 4°C
Door switch	 <p>CS-1</p>	24V 2W	※ Check resistance Normal : About 5MΩ
Switch (power max, one touch decel, horn, breaker)		24V 6A	※ Check resistance Normal : ∞Ω

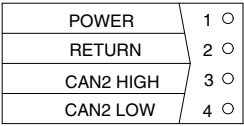
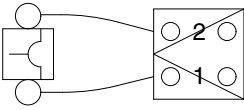
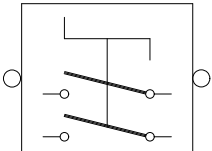
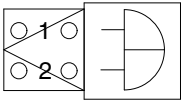
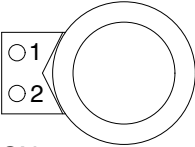
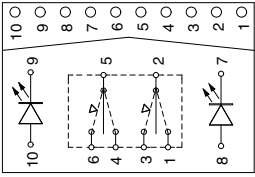
Part name	Symbol	Specifications	Check
Radar	 <p>CN-441</p>	-	-
Circuit breaker	 <p>CN-60 CN-95</p>	CN-60 : 60A CN-95 : 90A	※ Check disconnection Normal : 0Ω (connect ring terminal and check resist between terminal 1 and 2)
Master switch	 <p>CS-74B</p>	6-36V	※ Check disconnection Normal : 0.1Ω
Quick clamp buzzer	 <p>CN-113</p>	24V 200mA 107 ± 4dB	-
Socket	 <p>CN-139</p>	12V 10A	-
SCR switch	 <p>CS-100</p>	24V 8A	※ Check contact Normal OFF : ∞Ω (for terminal 2-1, 2-3, 4-5, 5-6)

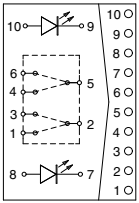
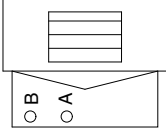
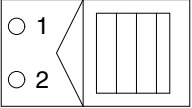
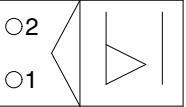
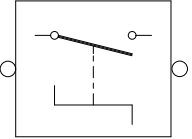
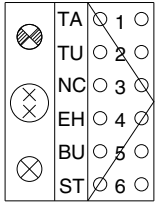
Part name	Symbol	Specifications	Check
Select switch	 <p>CS-120, CS-122, CS-123</p>	24V 8A	※ Check contact Normal 0 or : $\infty \Omega$ (for terminal 2-1, 2-3, 4-5, 5-6)
Fuel heater	 <p>CN-96</p>	-	-
DEF/AdBlue® line heater	 <p>CN-381 CN-382 CN-383</p>	-	-
WIF sensor	 <p>CD-45</p>	-	※ Check disconnection Normal : 68.8~4.94 Ω
Master switch	 <p>CS-74</p>	6 - 36V	※ Check disconnection Normal : 0.1 Ω
Rear combination lamp-LH,RH	 <p>CL-15 CL-16</p>	24V 21W×2 LED	※ Check resistance Normal : 4.8 Ω (For terminal 1-4) Normal : 2.1 Ω (For terminal 2-4, 4-5, 4-6)

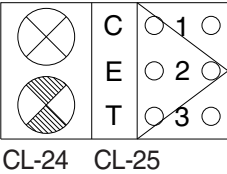
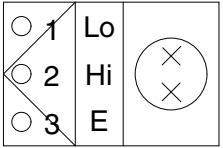
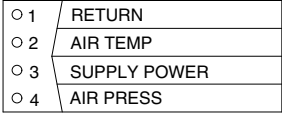
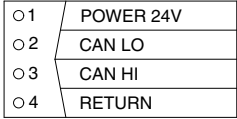
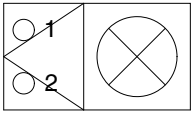
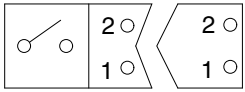
Part name	Symbol	Specifications	Check
Front combination lamp-LH, RH	 <p>CL-24 CL-25</p>	24V 21W 24V 10W	※ Check resistance Normal : 4.8Ω (For terminal 1-2) Normal : 2.1Ω (For terminal 2-3)
Head lamp -LH, RH	 <p>CL-3 CL-4</p>	24V 75/70W	※ Check resistance Normal : 1.0Ω (For terminal 1-3, 2-3) Normal : 1.5Ω (For terminal 1-2)
Pressure temperature sensor	 <p>CD-10</p>	5.0V 0.2A	※ Check contact Normal 0Ω (for terminal 1-2, 47.5Ω) ∞Ω (for terminal 3-1, 1kΩ) ∞Ω (for terminal 4-1, 1kΩ)
Sensor (NOx, SCR, DOC)	 <p>CN-J7A CN-J7B CN-J10 CN-J17</p>	-	-
DEF/AdBlue® fill up warning lamp (LED)	 <p>CL-40</p>	-	-
Seat belt switch	 <p>CS-250</p>	-	-

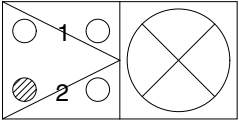
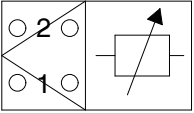
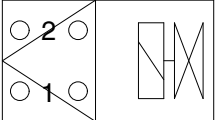
Part name	Symbol	Specifications	Check								
DEF/AdBlue® full lamp	 CL-40	-	-								
DEF lamp	<table border="1" data-bbox="432 593 746 712"> <tr> <td>○ 1</td> <td>NC</td> </tr> <tr> <td>○ 14</td> <td>NC</td> </tr> <tr> <td>○ 5</td> <td>DEF LAMP</td> </tr> </table> CCID	○ 1	NC	○ 14	NC	○ 5	DEF LAMP	-	-		
○ 1	NC										
○ 14	NC										
○ 5	DEF LAMP										
Air conditioner temperature sensor (incar, ambient)		-	-								
EPPR valve	 CN-384 CN-J31	24V 700mA	※ Check resistance Normal : 15~25Ω (For terminal 1-2)								
DEF/AdBlue® tank level sensor	<table border="1" data-bbox="443 1420 715 1554"> <tr> <td>○ 1</td> <td>POWER</td> </tr> <tr> <td>○ 2</td> <td>RETURN</td> </tr> <tr> <td>○ 3</td> <td>CAN HIGH</td> </tr> <tr> <td>○ 4</td> <td>CAN LOW</td> </tr> </table> CN-380	○ 1	POWER	○ 2	RETURN	○ 3	CAN HIGH	○ 4	CAN LOW	-	-
○ 1	POWER										
○ 2	RETURN										
○ 3	CAN HIGH										
○ 4	CAN LOW										
TBAP	<table border="1" data-bbox="424 1693 746 1821"> <tr> <td>○ 1</td> <td>AIR PRESS</td> </tr> <tr> <td>○ 2</td> <td>POWER SUPPLY</td> </tr> <tr> <td>○ 3</td> <td>AIR TEMP</td> </tr> <tr> <td>○ 4</td> <td>RETURN</td> </tr> </table> EX2B	○ 1	AIR PRESS	○ 2	POWER SUPPLY	○ 3	AIR TEMP	○ 4	RETURN	-	-
○ 1	AIR PRESS										
○ 2	POWER SUPPLY										
○ 3	AIR TEMP										
○ 4	RETURN										

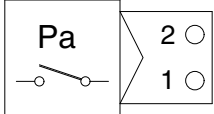
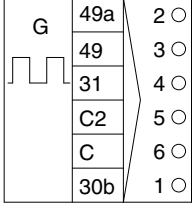
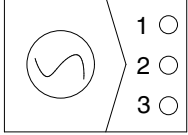
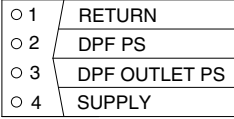
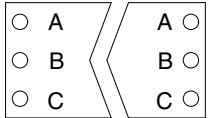
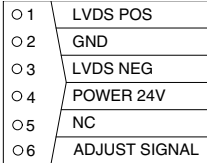
Part name	Symbol	Specifications	Check
Dozer act pressure switch	 <p>CD-50</p>	N.O type	※ Check resistance Normal : ∞ Ω (open)
Flasher unit	 <p>CR-11</p>	24V 85~190 C/M 50dB	-
Speed sensor	 <p>CD-46</p>	-	-
DEF Dif pressure sensor	 <p>AT11A</p>	-	-
Smart button	 <p>CS-2B</p>	-	-
Camera	 <p>CN-249 CN-402 CN-403 CN-404 CN-405</p>	-	-

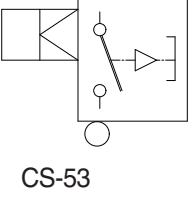
Part name	Symbol	Specifications	Check
Wiper cutoff switch	 <p>CS-53</p>	24V N.O type	※ Check contact Normal : $\infty \Omega$ (one pin to ground)

GROUP 4 CONNECTORS

1. CONNECTOR DESTINATION

Connector number	Type	No. of pin	Destination	Connector part No.	
				Female	Male
CN-2	DELPHI	15	I/conn (Frame harness-Engine harness)	2-85262-1	368301-1
CN-3	TYCO	12	I/conn (Frame harness-Engine harness)	174661-2	368537-1
CN-3A	TYCO	15	I/conn (Frame harness-PVG harness)	2-85262-1	368301-1
CN-4	AMP	16	I/conn (Console harness LH-Frame harness)	368047-1	S816-116002
CN-5	DEUTSCH	60	I/conn (Side harness RH-Frame harness)	DRB16-60SAE-L018	DRB12-60PAE-L018
CN-6	AMP	16	I/conn (Console harness RH-Frame harness)	368047-1	S816-116002
CN-7	AMP	15	I/conn (Console harness RH-Frame harness)	2-85262-1	368301-1
CN-7A	AMP	12	I/conn (Console harness RH-Frame harness)	174661-2	368537-1
CN-8	AMP	10	I/conn (Console harness RH-Frame harness)	S816-010002	S816-110002
CN-9	DEUTSCH	12	I/conn (Frame harness-AAVM harness)	DT06-12S	DT04-12P
CN-10	DEUTSCH	12	I/conn (Cab harness-Side harness RH)	DT06-12S-EP06	DT04-12PA-P021
CN-11	DEUTSCH	8	Air conditioner harness	DT06-8S-EP06	-
CN-12	DEUTSCH	2	I/conn (Frame harness-Boom wire harness)	DT06-2S-EP06	DT04-2P-E005
CN-14	DEUTSCH	6	I/conn (Frame harness-swing parking harness)	DT06-6S-EP06	DT04-6P-EP06
CN-16	AMP	6	Emergency engine start & speed control	S816-006002	S816-106002
CN-16A, B	AMP	6	Emergency engine start & speed control	S816-006002	-
CN-20	DEUTSCH	2	Horn	DT06-2S-EP06	-
CN-21	DEUTSCH	4	Wiper motor	DT06-4S-EP06	-
CN-22	KET	2	Washer pump	MG640605	-
CN-23	KET	2	Speaker-LH	MG610070	-
CN-24	KET	2	Speaker-RH	MG610070	-
CN-25	DEUTSCH	2	Horn	DT06-2S-EP06	-
CN-27A	KUM	16	Radio & USB player	PK145-16017	-
CN-27B	AMP	8	USB player	-	174984-2
CN-28	KET	2	Aircon compressor	MG610320	-
CN-29	KET	2	Receiver dryer	MG640795	-
CN-31	-	2	Fuse 1	-	174352-2
CN-32	-	2	Fuse 1	-	174352-2
CN-36	TYCO	-	Fuse box (micro relay)	-	3-1393292-8
CN-45	RING-TERM	-	Starter motor B+ /G terminal	S820-410000	-
CN-45	RING-TERM	-	Starter motor M terminal	ST710246-2	-
CN-48	KET	1	Service meter	2-520193-2	-
CN-51	TE	34	MCU	2-1437285-3	-
CN-52	TE	34	MCU	4-1437290-1	-
CN-53	TE	26	MCU	1473416-1	-

Connector number	Type	No. of pin	Destination	Connector part No.	
				Female	Male
CN-54	TE	34	MCU	4-1437290-0	-
CN-56A	AMP	12	Cluster	-	174663-2
CN-56B	AMP	8	Cluster	-	174984-2
CN-60	YAZAKI	2	Circuit breaker	-	7222-4220-30
CN-61	DEUTSCH	2	Fuel filler pump	DT06-2S-EP06	DT04-2P-E005
CN-68	DEUTSCH	2	Safety solenoid	DT06-2S-EP06	-
CN-69	DEUTSCH	2	Ram lock solenoid	DT06-2S-EP06	-
CN-70	DEUTSCH	2	Travel high solenoid	DT06-2S-EP06	-
CN-74	RING-TERM	1	Alternator "L" terminal	MG820-105000	-
CN-74	RING-TERM	1	Alternator "B+" terminal	MG820-108000	-
CN-74	RING-TERM	1	Alternator "G" terminal	MG820-306001	-
CN-75	DEUTSCH	2	Main pump shift EPPR valve	DT06-2S-EP06	-
CN-75A	DEUTSCH	2	Main pump DP EPPR valve	DT06-2S-EP06	-
CN-80	RING-TERM	-	Glow plug	S820-406001	-
CN-81	DEUTSCH	2	Travel buzzer solenoid	DT06-2S-EP06	-
CN-88	DEUTSCH	2	Power max solenoid	DT06-2S-EP06	-
CN-93	DELPHI	96	To ECU	13964577	-
CN-95	YAZAKI	2	Circuit breaker	-	722-4220-30
CN-96	-	2	Fuel warmer	1530 0027	-
CN-100	KET	1	Battery earth	MG640994-5	-
CN-113	KET	2	Quick clamp buzzer	MG651205-5	-
CN-122	DEUTSCH	2	Forward solenoid	DT06-2S-EP06	-
CN-123	DEUTSCH	2	Reverse solenoid	DT06-2S-EP06	-
CN-125	Econoseal J	4	GPS connector	S816-004002	S816-104002
CN-125A	DEUTSCH	12	GPS	DT06-12S-P021	DT04-12PA-P021
CN-125B	DEUTSCH	8	RMS	DT06-8S	DT04-8P
CN-126	AMP	10	I/conn (Frame harness-Service tool)	S816-010002	S816-110002
CN-126	DEUTSCH	9	Service tool	-	HD10-9-969
CN-126A	DEUTSCH	4	RMS service tool	DT06-4S	DT04-4P
CN-131	-	6	I/conn (Stop lamp harness-Frame harness)	S816-006002	S816-106002
CN-132	DEUTSCH	2	Safety solenoid	DT06-2S-EP06	-
CN-138	FASTEN	3	DC/DC Converter	S810-003202	-
CN-139	FASTEN	2	12V socket	172434-2	-
CN-140	DEUTSCH	2	Quick clamp solenoid	DT06-2S-EP06	DT04-2P-E005
CN-147	-	2	Fuel heater	1530 00 27	-
CN-154	DEUTSCH	2	Fan EPPR	DT06-2S-EP06	-
CN-155	DEUTSCH	2	Fan reverse solenoid	DT06-2S-EP06	-
CN-156	DEUTSCH	60	MTCU	DRC26-40SA	-
CN-156	AMP	2	Air seat	-	S822-114002

Connector number	Type	No. of pin	Destination	Connector part No.	
				Female	Male
CN-157	AMP	1	Antena power	S822-014002	-
CN-168	DEUTSCH	12	PVED-CLS	DT06-12S	-
CN-173	DEUTSCH	3	Resistor	DT06-3S-EP06	DT04-3P-EP10
CN-174	DEUTSCH	3	Resistor	DT06-3S-EP06	-
CN-181	DEUTSCH	2	Travel low speed solenoid	DT06-2S-EP06	-
CN-197	DEUTSCH	2	Swing brake solenoid	DT06-2S-EP06	-
CN-206	DEUTSCH	2	Creep solenoid	DT06-2S-EP06	-
CN-214	DEUTSCH	2	Front outrigger solenoid - RH	DT06-2S-EP06	DT04-2P-E005
CN-216	DEUTSCH	2	Front outrigger solenoid - LH	DT06-2S-EP06	DT04-2P-E005
CN-218	DEUTSCH	2	Rear outrigger solenoid - RH	DT06-2S-EP06	DT04-2P-E005
CN-220	DEUTSCH	2	Rear outrigger solenoid - LH	DT06-2S-EP06	DT04-2P-E005
CN-238	DEUTSCH	2	Rotate-LH	DT06-2S-EP06	DT04-2P
CN-239	DEUTSCH	2	Rotate-RH	DT06-2S-EP06	DT04-2P
CN-246	DEUTSCH	2	Cruise solenoid	DT06-2S-EP06	-
CN-246	DEUTSCH	8	PVG switch	DT06-8S	-
CN-247	DEUTSCH	8	PVG signal	DT06-8S	-
CN-249	DEUTSCH	6	Rear view camera	DT06-6S-EP06	DT04-6P
CN-255	-	16	Slipring	368047-1	8-1447231-9
CN-255A	DEUTSCH	8	Trailer hitch	DT06-8S	DT04-8P
CN-255B	-	7	Trailer socket	-	-
CN-305	DEUTSCH	12	PVG connector	DTM06-12SA	-
CN-306	DEUTSCH	12	PVG connector	DTM06-12SB	-
CN-307	DEUTSCH	3	Service tool	DT06-3S-EP06	DT04-3P-E005
CN-309	DEUTSCH	2	2 way release	DT06-2S-EP06	-
CN-310	DEUTSCH	2	2 way clamp	DT06-2S-EP06	-
CN-313	DEUTSCH	4	Service tool	DT06-4S	-
CN-363	-	12	Jog dial module	174045-2	-
CN-365	DEUTSCH	2	Attachment relief EPPR valve 1	DT06-2S-EP06	-
CN-366	DEUTSCH	2	Attachment relief EPPR valve 2	DT06-2S-EP06	-
CN-369	DEUTSCH	2	Boom down cut-off solenoid	DT06-2S-E005	DT04-2P-E005
CN-370	DEUTSCH	2	Swing fine control solenoid	DT06-2S-EP06	DT04-2P-E005
CN-376	TYCO	23	RDU	7706087-2	-
CN-379	TYCO	12	SCR supply module	2-1703639-1	-
CN-380	DEUTSCH	4	DEF/AdBlue® tank level sensor	DT06-4S-EP06	-
CN-381	DEUTSCH	2	DEF/AdBlue® line heater 1	DT06-2S-EP06	-
CN-382	DEUTSCH	2	DEF/AdBlue® line heater 2	DT06-2S-EP06	-
CN-383	DEUTSCH	2	DEF/AdBlue® line heater 3	DT06-2S-EP06	-
CN-384	TYCO	2	Coolant valve	1-967325-3	-
CN-401	TE	35	AAVM controller	776164-1	-

Connector number	Type	No. of pin	Destination	Connector part No.	
				Female	Male
CN-402	DEUTSCH	6	Front view camera	DT06-6S-P021	DT04-6P-P021
CN-403	DEUTSCH	6	Rear view camera	-	DT04-6P-EP14
CN-404	DEUTSCH	6	Left view camera	-	DT04-6P-EP14
CN-405	DEUTSCH	6	Right view camera	-	DT04-6P-EP14
CN-406	DEUTSCH	3	RS 232	DT06-3S-EP06	DT04-3P-E005
CN-406	AMP	34	CAM image controller	-	4-1437290-0
CN-419	DEUTSCH	2	Swing parking A1	DT06-2S-EP06	-
CN-420	DEUTSCH	2	Swing parking A2	DT06-2S-EP06	-
CN-421	DEUTSCH	2	Swing parking A3	DT06-2S-EP06	-
CN-427	MOLEX	12	Reader	5557-12R	5559-12P
CN-430	DEUTSCH	12	l/conn (Side harness RH-Aftertreatment harness)	DT06-12S-EP06	DT06-12P-E005
CN-431	KET	20	Aux monitor	MG653026	-
CN-444	DEUTSCH	2	Fuel filler pump switch 1	DT06-2S-EP06	DT04-2P-E005
CN-445	DEUTSCH	4	Fuel filler pump switch 2	DT06-4S-EP06	DT04-2P
CN-451	CARLING	10	Trailer indicator	VC2-01	-
CN-466	DEUTSCH	2	Tilt totator-RCV joystick steering	DT06-2S-EP06	-
CN-467	DEUTSCH	8	Tilt totator-cab	DT06-8SA-EP06	DT04-8PA-E003
CN-468	DEUTSCH	4	Tilt totator-attachment	DT06-4S-EP06	DT04-4P
CN-469	DEUTSCH	6	Tilt totator-AVUC	DT06-6S-EP06	DT04-6P
CN-500	DEUTSCH	6	Ride control solenoid connector	DT06-6S-EP06	-
CN-500	DEUTSCH	6	l/conn (Frame harness-Ride control harness)	DT06-6S-EP06	DT04-6P
CN-501	DEUTSCH	2	Ride control solenoid 1	DT06-2S-E005	-
CN-502	DEUTSCH	2	Ride control solenoid 2	DT06-2S-E005	-
CN-503	DEUTSCH	2	Ride control solenoid 3	DT06-2S-E005	DT04-2P-E005
CN-506	DEUTSCH	2	Lift solenoid	DT06-2S-EP06	DT04-2P
CN-507	DEUTSCH	2	Digging brake EPPR	DT06-2S-EP06	-
CN-508	DEUTSCH	2	Digging brake solenoid	DT06-2S-EP06	-
CN-J7A	TYCO	4	DOC NOx sensor	2-1418390-1	-
CN-J7B	TYCO	4	SCR NOx sensor	1-1418390-1	-
CN-J10	TYCO	4	SCR thermistor controller	5-1418390-1	-
CN-J17	TYCO	4	DOC thermistor controller	4-1418390-1	-
AT11A	FRAMATOME	4	DPF dift pressure sensor	-	54200410
CN-J31	BOSCH	2	DEF/AdBlue® dosing module	1_928_403_874	-
CC1D	FCI	14	DEF lamp connector	13533441	-
CC8D	DEUTSCH	4	Engine side crossover connector	DT06-4S-EP06	-
EX2B	FCI	4	TBAP	54200419	-
J-1	TE	20	Multifunction switch	-	1-0640514-0
J-2	TE	20	Multifunction switch	1-0640524-0	-

Connector number	Type	No. of pin	Destination	Connector part No.	
				Female	Male
· Relay					
CR-1	RING-TERM	1	Battery relay B+/IG terminal	ST710285-2	-
CR-2	-	5	Horn relay	-	-
CR-3	-	5	Working lamp relay	-	-
CR-4	-	5	Wiper relay	-	-
CR-5	-	5	Anti restart relay	-	-
CR-6	TE	4	Wiper relay - int	174202-1	-
CR-7	-	5	Aircon compressor relay	-	-
CR-9	-	5	Cabin lamp relay	-	-
CR-11	HELLA	6	Flasher unit relay	701-230-001	-
CR-12	-	5	Travel speed relay	-	-
CR-13	-	5	Head lamp low relay	-	-
CR-14	-	5	Head lamp high relay	-	-
CR-15	-	5	Illumination relay	-	-
CR-23	RINGTERM	1	Start relay S/G terminal	ST712089-2	-
CR-23	RINGTERM	1	Start relay B+/M terminal	ST710384-2	-
CR-24	RING TERM	1	Preheat relay B+/P terminal	S820-406001	-
CR-24	RING TERM	1	Preheat relay G terminal	S820-108000	-
CR-24	RING TERM	1	Preheat relay S terminal	S820-014000	-
CR-30	-	5	Travel reverse relay	-	-
CR-35	-	5	Power relay	-	-
CR-36	-	5	Preheat relay	-	-
CR-39	-	5	Starter lockout relay	-	-
CR-44	-	5	Rear work lamp relay	-	-
CR-45	-	5	Stop lamp relay	-	-
CR-46	-	5	Fuel warmer relay	-	-
CR-47	-	5	Safety solenoid relay	-	-
CR-49	-	5	Washer pump relay	-	-
CR-50	-	5	NOx sensor relay	-	-
CR-51	-	5	DEF module relay	-	-
CR-52	-	5	Line heater relay	-	-
CR-66	-	5	Parking relay	-	-
CR-69	-	5	Turn relay - RH	-	-
CR-70	-	5	Turn relay - LH	-	-
CR-78	-	5	Head lamp power relay	-	-
CR-81	-	5	Front outrigger relay - RH	-	-
CR-82	-	5	Front outrigger relay - LH	-	-
CR-83	-	5	Rear outrigger relay - RH	-	-
CR-84	-	5	Rear outrigger relay - LH	-	-

Connector number	Type	No. of pin	Destination	Connector part No.	
				Female	Male
CR-85	-	5	Beacon lamp relay	-	-
· Switch					
CS-1	SHUR	1	Door switch	S822-014002	-
CS-2A	WP	6	Start key switch	S814-006100	-
CS-2B	DEUTSCH	3	BKCU	DT06-3S-EP06	DT04-3P-E005
CS-2C	KET	3	BKCU	MG651032	-
CS-2D	KET	3	Button key	-	MG641035
CS-4	DEUTSCH	3	Safety switch	DT06-3S	-
CS-10	DEUTSCH	6	FNR switch	DT06-6S	-
CS-20	DEUTSCH	3	Safety switch	-	DT04-3P
CS-23	CARLING	10	Auto cruise switch	VC2-01	-
CS-29	DEUTSCH	6	Power max switch	DT06-6S	-
CS-33	-	6	Emergency engine stop switch	S816-006002	S816-106002
CS-61	-	2	Boom floating switch	174352-2	S816-102002
CS-67	CARLING	10	Quick clamp switch	VC2-01	-
CS-73	CARLING	10	Swing lock switch	VC2-01	-
CS-73A	CARLING	10	Fine swing switch	VC2-01	-
CS-74A	AMP	2	Master switch	S813-030201	-
CS-74B	DEUTSCH	2	Master switch	DT06-2S-EP06	-
CS-100	CARLING	10	SCR switch	VC2-01	-
CS-120	CARLING	10	Trailer lift switch	VC2-01	-
CS-121	CARLING	10	Auto digging brake switch	VC2-01	-
CS-122	CARLING	10	E steering & crusher switch	VC2-01	-
CS-123	CARLING	10	Boom float & ride control switch	VC2-01	-
CS-124	CARLING	10	FNR emergency switch	VC2-01	-
CS-125	CARLING	10	FNR select switch	VC2-01	-
CS-250	DEUTSCH	2	Seat belt switch	DT06-2S	-
· Light					
CL-1	KET	3	Room lamp	MG651032	-
CL-2	AMP	1	Cigar lighter	S822-014002 -	S822-114002 S810-001202
CL-3	-	3	Head lamp-LH	S810-003702	-
CL-4	-	3	Head lamp-RH	S810-003702	-
CL-5	DEUTSCH	2	Work lamp-LH	DT06-2S-E005	-
CL-6	DEUTSCH	2	Work lamp-RH	DT06-2S-E005	-
CL-7	DEUTSCH	2	Beacon lamp	DT06-2S-EP06	DT04-2P
CL-8	DEUTSCH	2	Cab light-LH	DT06-2S-EP06	DT04-2P
CL-9	DEUTSCH	2	Cab light-RH	DT06-2S-EP06	DT04-2P
CL-10	DEUTSCH	2	Cab light-RH	DT06-2S-EP06	DT04-2P

Connector number	Type	No. of pin	Destination	Connector part No.	
				Female	Male
CL-15	AMP	6	Rear combination lamp-LH	S816-006002	-
CL-16	AMP	6	Rear combination lamp-RH	S816-006002	-
CL-21	KET	2	Lisense lamp	S814-002000	S814-102000
CL-21A	KET	2	Lisense lamp	S814-002000	-
CL-24	AMP	3	Front combination lamp-LH	S816-003002	-
CL-24	DEUTSCH	2	Rear work lamp	DT06-2S-EP06	DT04-2P-E005
CL-25	AMP	3	Front combination lamp-RH	S816-003002	-
CL-40	DEUTSCH	2	DEF/AdBlue® lamp	DT06-2S-EP06	-
· Sensor, sendor					
CD-1	AMP	2	Hydraulic oil temp sender	85202-1	-
CD-2	DEUTSCH	2	Fuel level sender	DT06-2S-EP06	-
CD-3	DEUTSCH	3	Brake oil pressure sensor	DT06-3S-EP06	-
CD-4	DEUTSCH	3	Stop lamp pressure sensor	DT06-3S-EP06	-
CD-5	DEUTSCH	3	Transmission oil pressure sensor	DT06-3S-EP06	-
CD-10A	SUMITOMO	4	TBAP	6098-0144	-
CD-16	AMP	3	Water level sensor	1211-0293	-
CD-24	DEUTSCH	3	Swing pressure sensor	DT06-3S-EP06	-
CD-31	DEUTSCH	3	Overload pressure sensor	DT06-3S-EP06	DT04-3P-E005
CD-32	DEUTSCH	3	Boom up pressure sensor	DT06-3S-EP06	-
CD-35	DEUTSCH	3	Arm out pressure sensor	DT06-3S-EP06	-
CD-37	DEUTSCH	3	2 piece pressure sensor	DT06-3S-EP06	DT04-3P
CD-38	DEUTSCH	3	Work brake pressure sensor	DT06-3S-EP06	-
CD-39	DEUTSCH	3	Pump load sensing pressure sensor	DT06-3S-EP06	-
CD-42	DEUTSCH	3	P1 pressure sensor	DT06-3S-EP06	-
CD-44	DEUTSCH	3	Pump option pressure sensor	DT06-3S-EP06	-
CD-45	DEUTSCH	2	WIF sensor	DT06-2S-EP06	-
CD-46	AMP	3	Speed sensor	282087	-
CD-50	KET	2	Outtrigger action pressure sensor	MG640975	-
CD-52	-	2	Fan speed sensor	174352-2	-
CD-57	DEUTSCH	4	SASA S/S	DT06-4S	-
CD-73	DEUTSCH	3	Travel forward pressure sensor	DT06-3S-EP06	-
CD-85	DEUTSCH	3	Boom down pressure sensor	DT06-3S-EP06	-
CD-87	DEUTSCH	3	Bucket out pressure sensor	DT06-3S-EP06	-
CD-90	DEUTSCH	3	Arm in pressure sensor	DT06-3S-EP06	-
CD-95	DEUTSCH	3	Bucket in pressure sensor	DT06-3S-EP06	-
CD-100	DEUTSCH	3	Outtrigger pressure sensor	DT06-3S-EP06	-
CD-101	DEUTSCH	3	Load sensing pressure sensor	DT06-3S-EP06	-
CD-102	DEUTSCH	3	Brake pressure sensor	DT06-3S-EP06	-
CD-124	DEUTSCH	3	Boom rod cylinder pressure sensor	DT06-3S-E005	-

Connector number	Type	No. of pin	Destination	Connector part No.	
				Female	Male
CD-145	DEUTSCH	3	Option RH - A	DT06-3S-EP06	DT04-3P-E005
CD-146	DEUTSCH	3	Option RH - B	DT06-3S-EP06	DT04-3P-E005
CD-156	DEUTSCH	3	Swing brake pressure sensor	DT06-3S-EP06	DT04-3P

2. CONNECTION TABLE FOR CONNECTORS

1) PA TYPE CONNECTOR

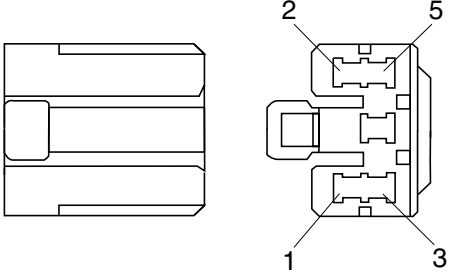
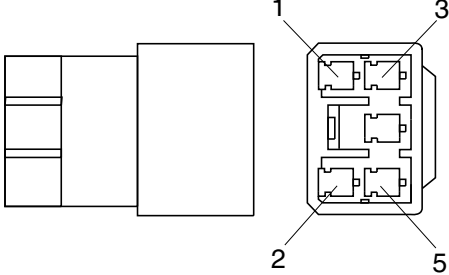
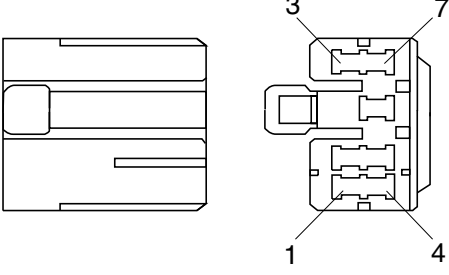
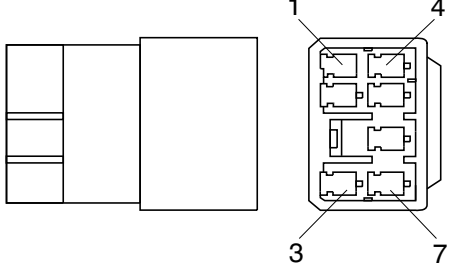
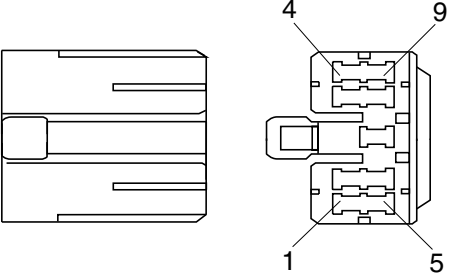
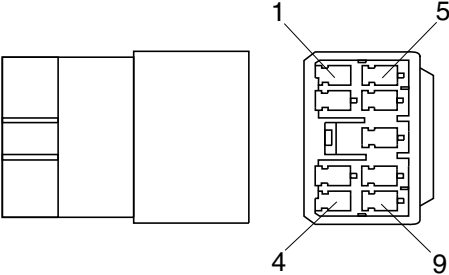
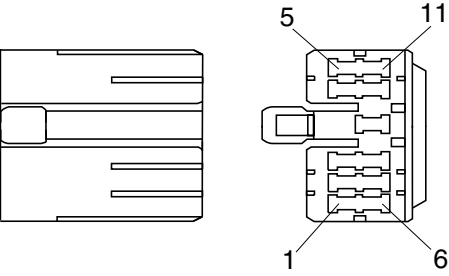
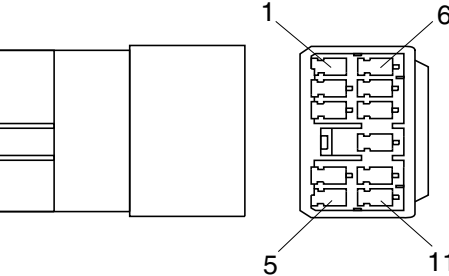
No. of pin	Receptacle connector (female)	Plug connector (male)
5	 <p data-bbox="687 734 836 768">S811-005002</p>	 <p data-bbox="1241 734 1390 768">S811-105002</p>
7	 <p data-bbox="687 1144 836 1178">S811-007002</p>	 <p data-bbox="1241 1144 1390 1178">S811-107002</p>
9	 <p data-bbox="687 1552 836 1585">S811-009002</p>	 <p data-bbox="1230 1552 1378 1585">3S811-109002</p>
11	 <p data-bbox="687 1960 836 1993">S811-011002</p>	 <p data-bbox="1241 1960 1390 1993">S811-111002</p>

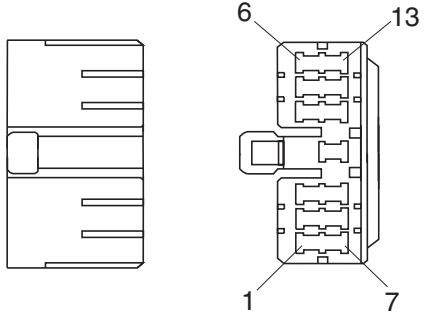
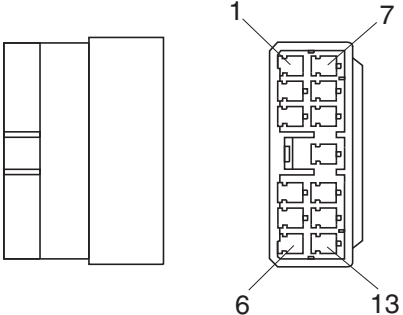
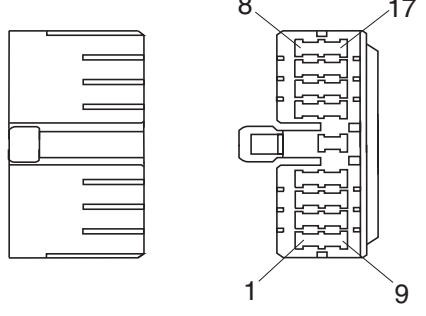
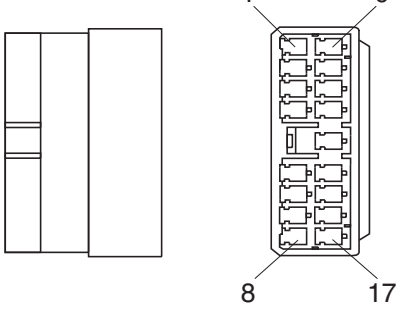
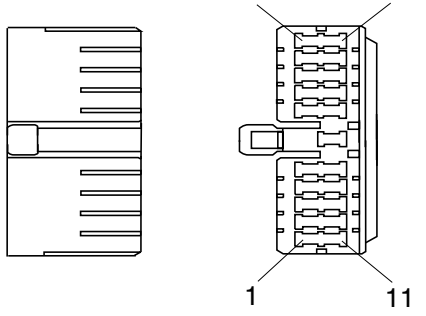
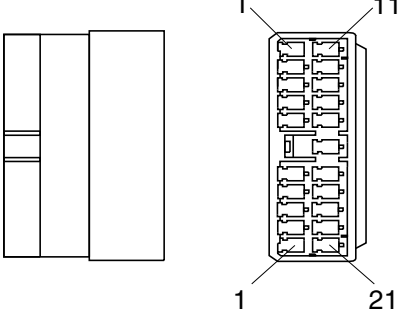
No. of pin	Receptacle connector (female)	Plug connector (male)
13	 <p data-bbox="689 645 842 674">S811-013002</p>	 <p data-bbox="1248 645 1401 674">S811-113002</p>
17	 <p data-bbox="689 1059 842 1088">S811-017002</p>	 <p data-bbox="1248 1059 1401 1088">S811-117002</p>
21	 <p data-bbox="689 1462 842 1491">S811-021002</p>	 <p data-bbox="1248 1462 1401 1491">S811-121002</p>

2) J TYPE CONNECTOR

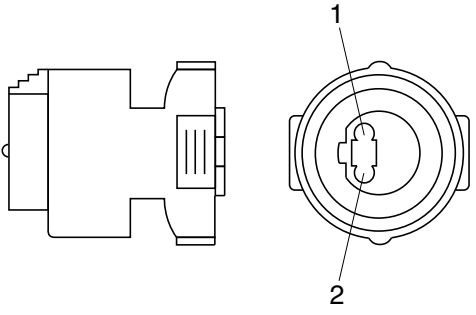
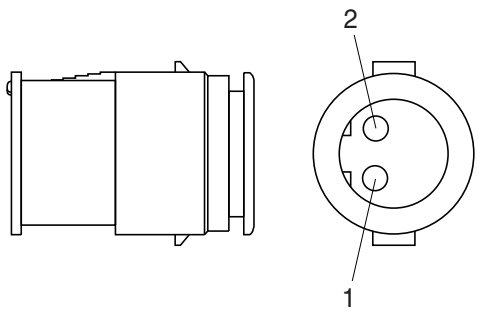
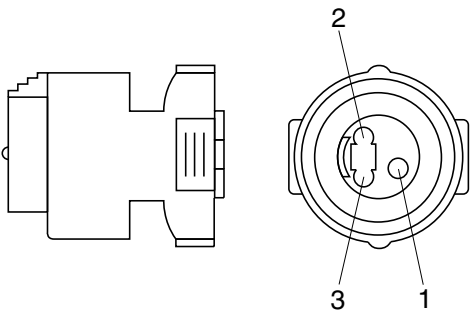
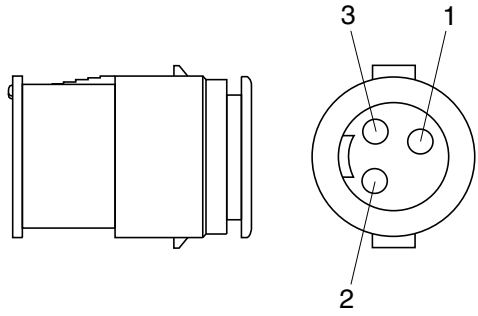
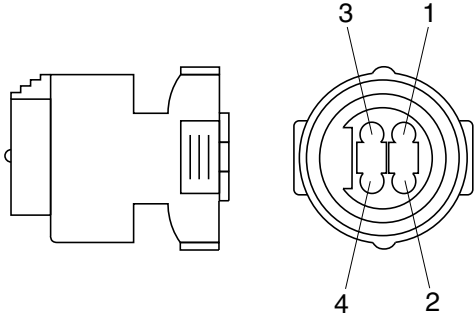
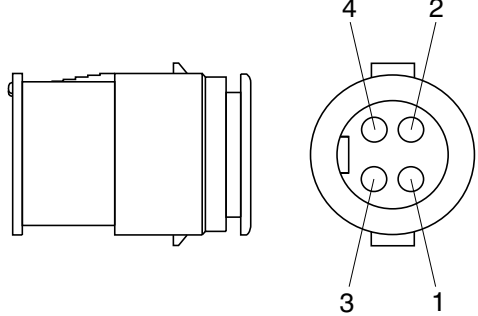
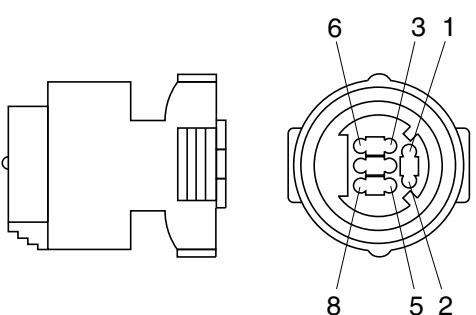
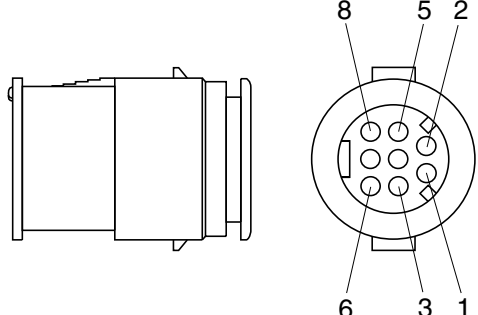
No. of pin	Receptacle connector (female)	Plug connector (male)
2	 <p style="text-align: center;">S816-002001</p>	 <p style="text-align: center;">S816-102001</p>
3	 <p style="text-align: center;">S816-003001</p>	 <p style="text-align: center;">S816-103001</p>
4	 <p style="text-align: center;">S816-004001</p>	 <p style="text-align: center;">S816-104001</p>
8	 <p style="text-align: center;">S816-008001</p>	 <p style="text-align: center;">S816-108001</p>

3) SWP TYPE CONNECTOR

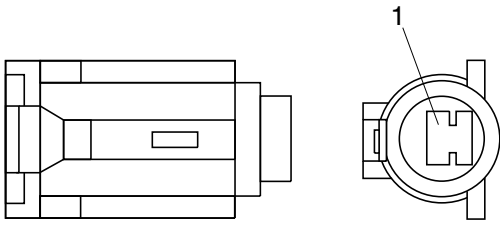
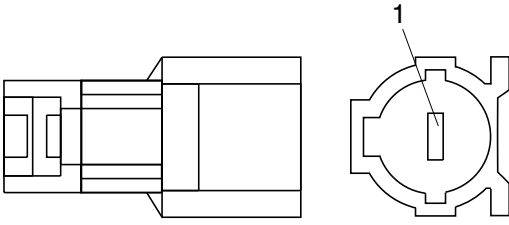
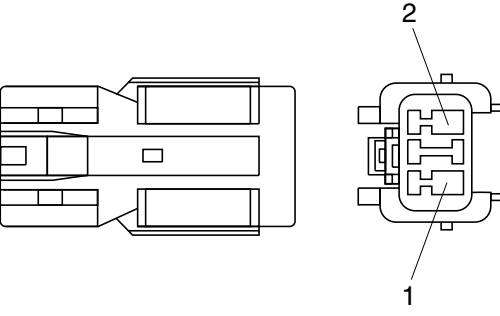
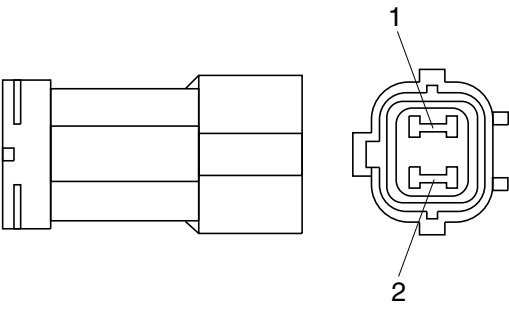
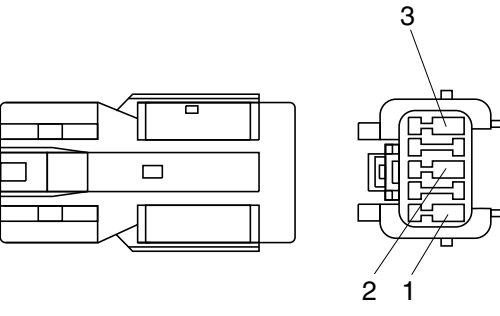
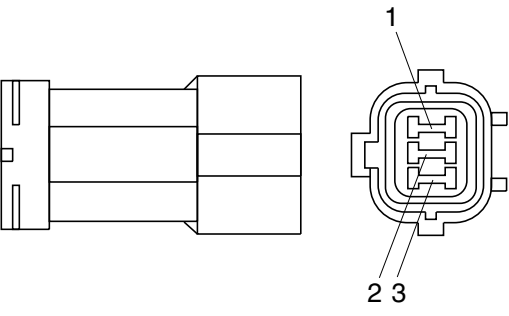
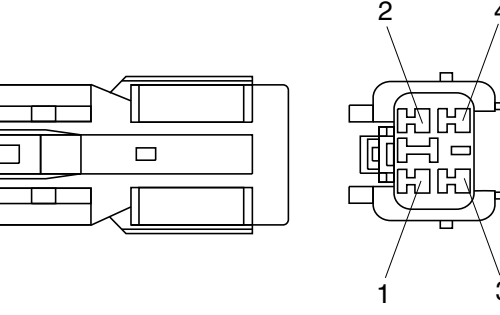
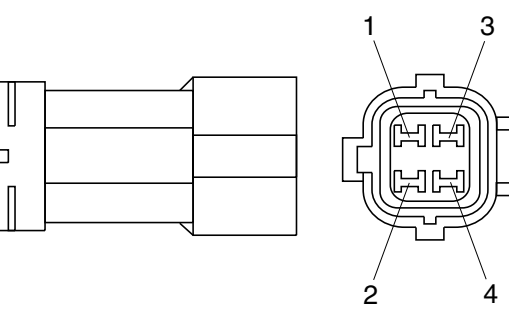
No. of pin	Receptacle connector (female)	Plug connector (male)
1	 <p data-bbox="686 683 837 716">S814-001000</p>	 <p data-bbox="1236 683 1388 716">S814-101000</p>
2	 <p data-bbox="686 1086 837 1120">S814-002000</p>	 <p data-bbox="1236 1086 1388 1120">S814-102000</p>
3	 <p data-bbox="686 1489 837 1523">S814-003000</p>	 <p data-bbox="1236 1489 1388 1523">S814-103000</p>
4	 <p data-bbox="686 1892 837 1926">S814-004000</p>	 <p data-bbox="1236 1892 1388 1926">S814-104000</p>

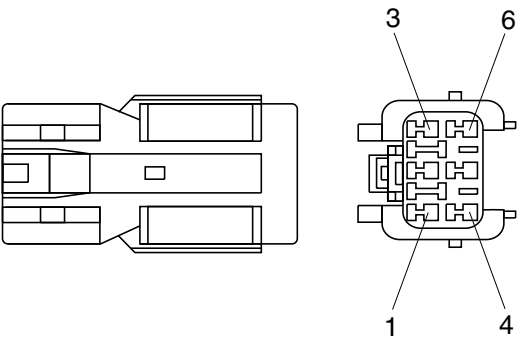
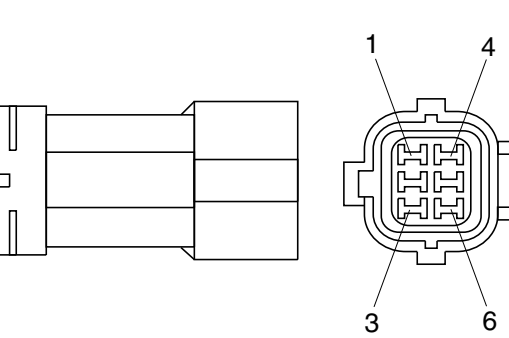
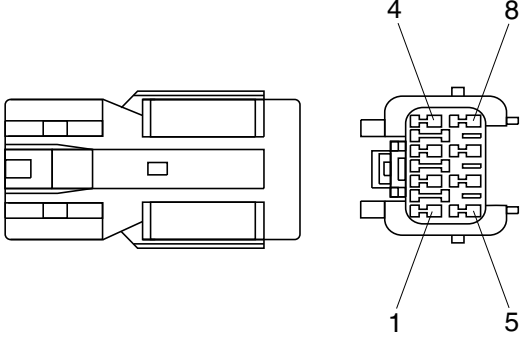
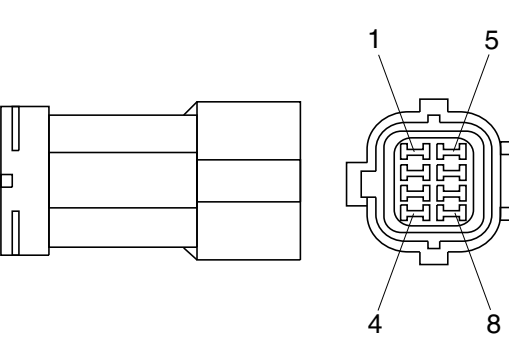
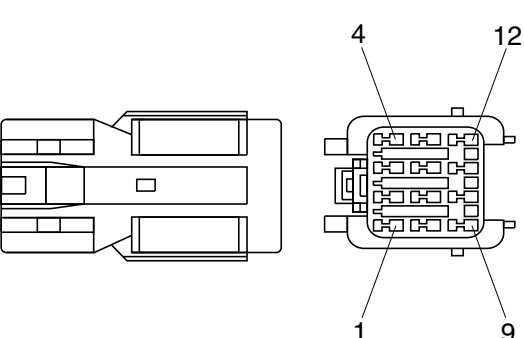
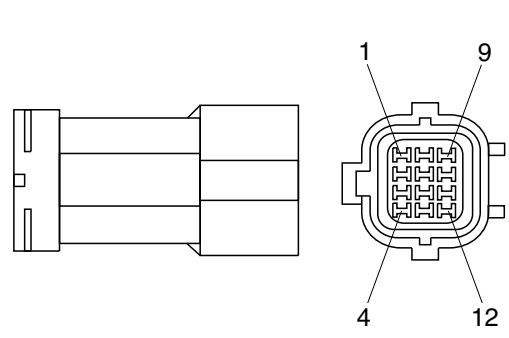
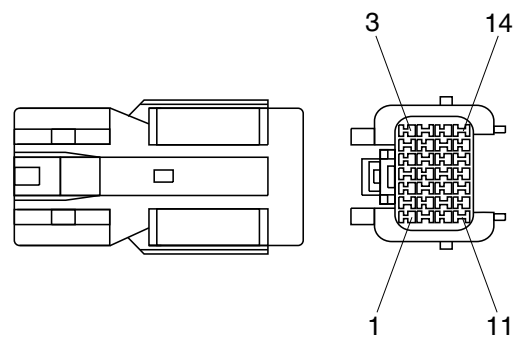
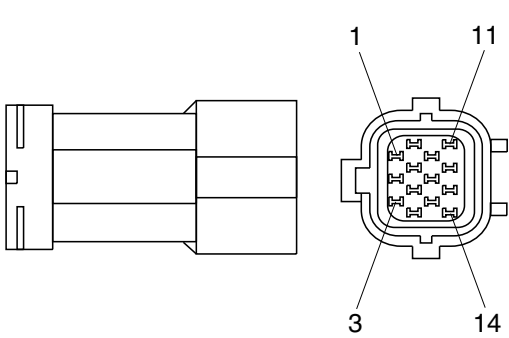
No. of pin	Receptacle connector (female)	Plug connector (male)
6	 <p data-bbox="694 638 837 672">S814-006000</p>	 <p data-bbox="1252 638 1396 672">S814-106000</p>
8	 <p data-bbox="694 1041 837 1075">S814-008000</p>	 <p data-bbox="1252 1041 1396 1075">S814-108000</p>
12	 <p data-bbox="694 1444 837 1478">S814-012000</p>	 <p data-bbox="1252 1444 1396 1478">S814-112000</p>
14	 <p data-bbox="694 1848 837 1881">S814-014000</p>	 <p data-bbox="1252 1848 1396 1881">S814-114000</p>

4) CN TYPE CONNECTOR

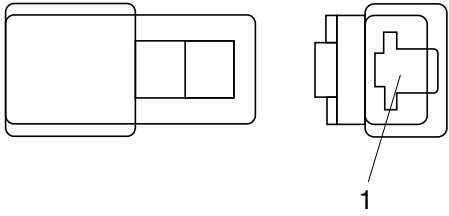
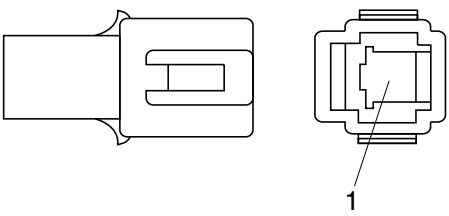
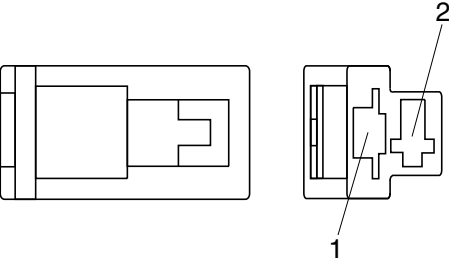
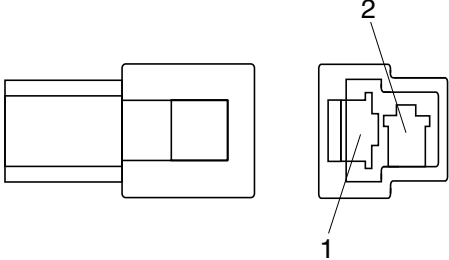
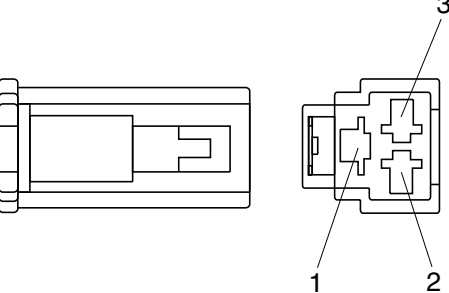
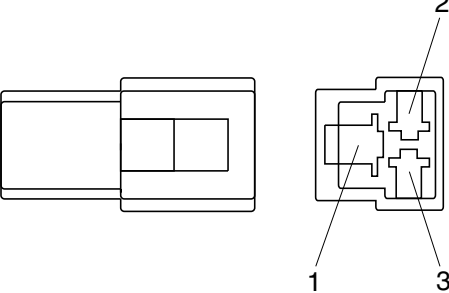
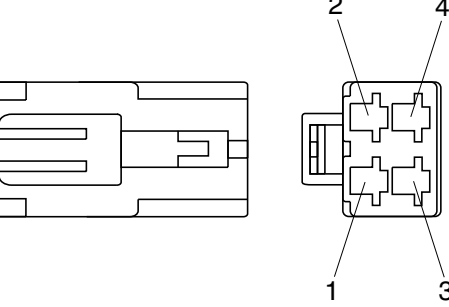
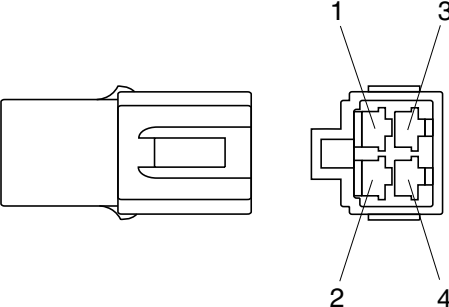
No. of pin	Receptacle connector (female)	Plug connector (male)
1	 <p style="text-align: center;">S810-001202</p>	 <p style="text-align: center;">S810-101202</p>
2	 <p style="text-align: center;">S810-002202</p>	 <p style="text-align: center;">S810-102202</p>
3	 <p style="text-align: center;">S810-003202</p>	 <p style="text-align: center;">S810-103202</p>
4	 <p style="text-align: center;">S810-004202</p>	 <p style="text-align: center;">S810-104202</p>

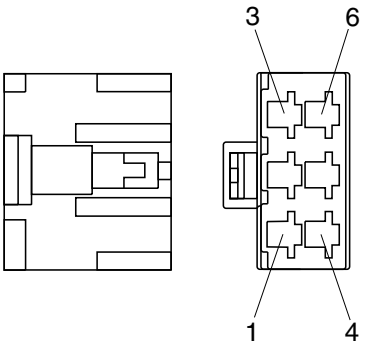
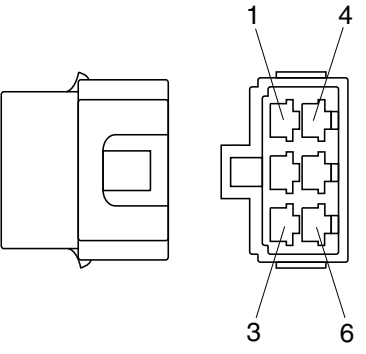
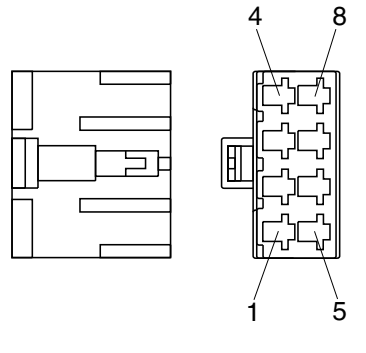
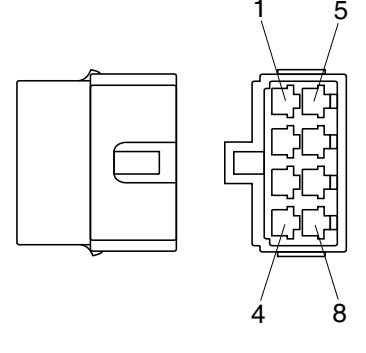
No. of pin	Receptacle connector (female)	Plug connector (male)
6	 <p data-bbox="686 645 837 674">S810-006202</p>	 <p data-bbox="1244 645 1396 674">S810-106202</p>
8	 <p data-bbox="686 1059 837 1088">S810-008202</p>	 <p data-bbox="1244 1059 1396 1088">S810-108202</p>

5) 375 FASTEN TYPE CONNECTOR

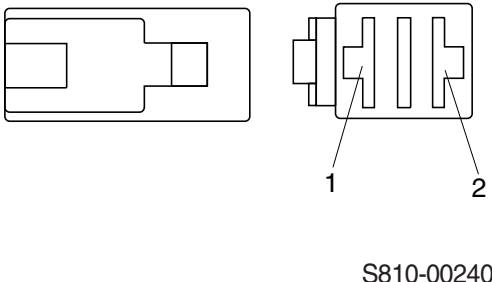
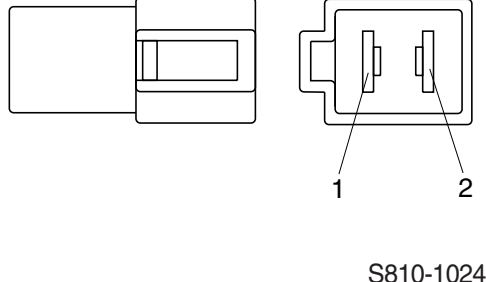
No. of pin	Receptacle connector (female)	Plug connector (male)
2	 <p style="text-align: center;">S810-002402</p>	 <p style="text-align: center;">S810-102402</p>

6) AMP ECONOSEAL CONNECTOR

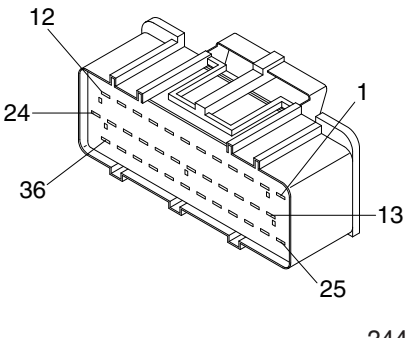
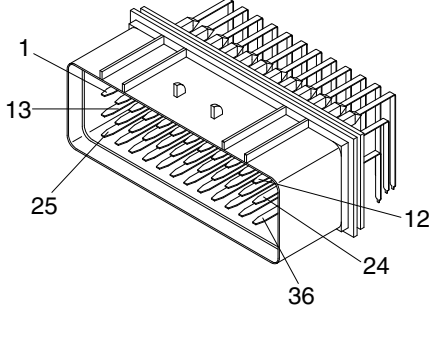
No. of pin	Receptacle connector (female)	Plug connector (male)
36	 <p style="text-align: center;">344111-1</p>	 <p style="text-align: center;">344108-1</p>

7) AMP TIMER CONNECTOR

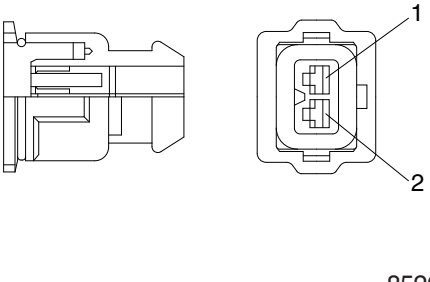
No. of pin	Receptacle connector (female)	Plug connector (male)
2	 <p style="text-align: center;">85202-1</p>	

8) AMP 040 MULTILOCK CONNECTOR

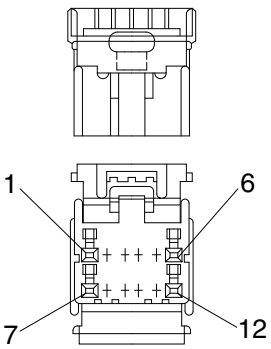
No. of pin	Receptacle connector (female)	Plug connector (male)
12	 <p style="text-align: right;">174045-2</p>	

9) AMP 070 MULTILOCK CONNECTOR

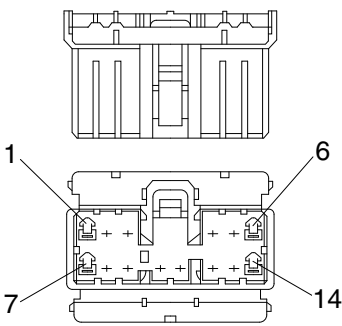
No. of pin	Receptacle connector (female)	Plug connector (male)
14	 <p style="text-align: right;">173852</p>	

10) AMP FASTIN - FASTON CONNECTOR

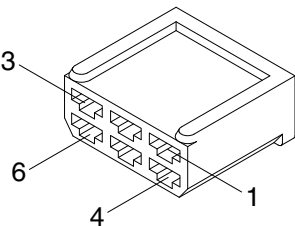
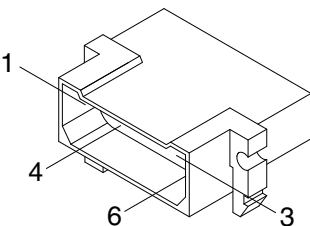
No. of pin	Receptacle connector (female)	Plug connector (male)
6	 <p style="text-align: right;">925276-0</p>	 <p style="text-align: right;">480003-9</p>

11) KET 090 CONNECTOR

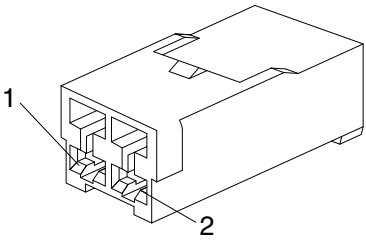
No. of pin	Receptacle connector (female)	Plug connector (male)
2	 <p style="text-align: right;">MG610070</p>	

12) KET 090 WP CONNECTORS

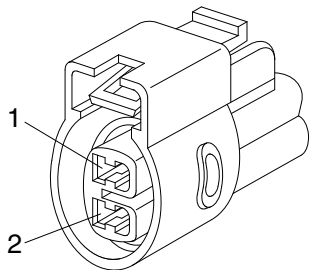
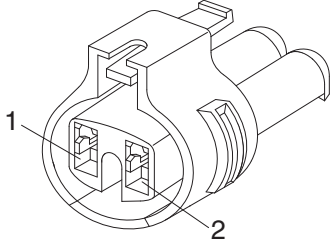
No. of pin	Receptacle connector (female)	Plug connector (male)
2	 <p style="text-align: right;">MG640605</p>	
2	 <p style="text-align: right;">MG640795</p>	

13) KET SDL CONNECTOR

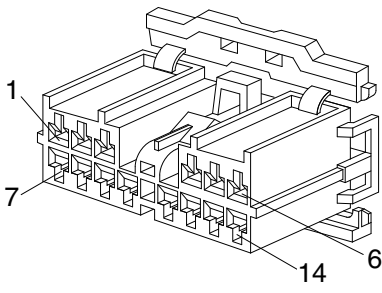
No. of pin	Receptacle connector (female)	Plug connector (male)
14	 <p>MG610406</p>	

14) DEUTSCH DT CONNECTORS

DT 06 - 3S - ★★☆☆

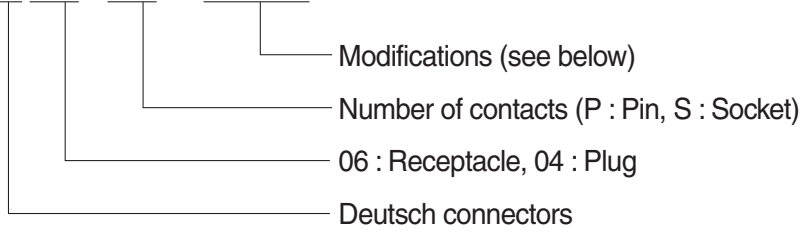

※ Modification

E003 : Standard end cap - gray

E004 : Color of connector to be black

E005 : Combination - E004 & E003

EP04 : End cap

EP06 : Combination P012 & EP04

P012 : Front seal enhancement - connectors color to black for 2, 3, 4 & 6pin

No. of pin	Receptacle connector (female)	Plug connector (male)
2	<p style="text-align: center;">DT06-2S</p>	<p style="text-align: center;">DT04-2P</p>
3	<p style="text-align: center;">DT06-3S</p>	<p style="text-align: center;">DT04-3P</p>
4	<p style="text-align: center;">DT06-4S</p>	<p style="text-align: center;">DT04-4P</p>

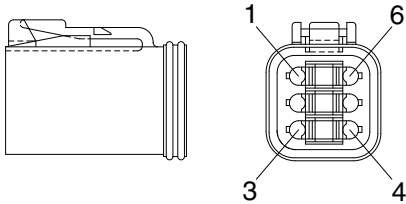
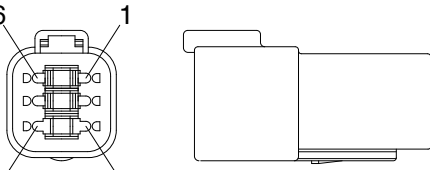
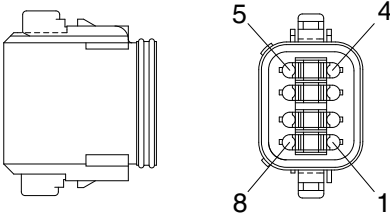
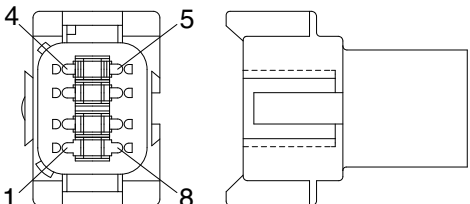
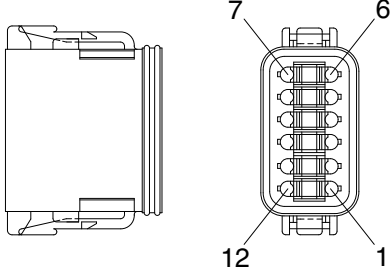
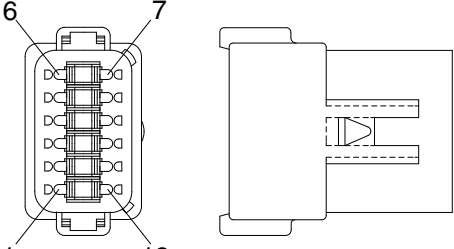
No. of pin	Receptacle connector (female)	Plug connector (male)
6	 <p style="text-align: center;">DT06-6S</p>	 <p style="text-align: center;">DT04-6P</p>
8	 <p style="text-align: center;">DT06-8S</p>	 <p style="text-align: center;">DT04-8P</p>
12	 <p style="text-align: center;">DT06-12S</p>	 <p style="text-align: center;">DT04-12P</p>

15) MOLEX 2CKTS CONNECTOR

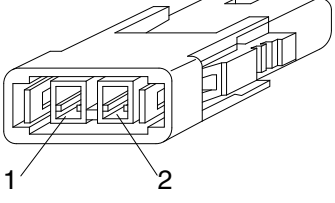
No. of pin	Receptacle connector (female)	Plug connector (male)
2	 <p data-bbox="702 683 837 705">35215-0200</p>	

16) ITT SWF CONNECTOR

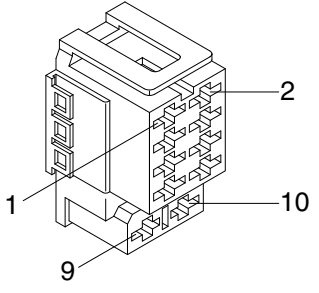
No. of pin	Receptacle connector (female)	Plug connector (male)
10	 <p data-bbox="694 1276 837 1299">SWF593757</p>	

17) MWP NMWP CONNECTOR

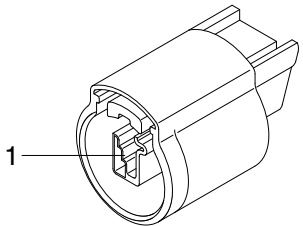
No. of pin	Receptacle connector (female)	Plug connector (male)
1	 <p data-bbox="686 1892 837 1915">NMWP01F-B</p>	

18) ECONOSEAL J TYPE CONNECTORS

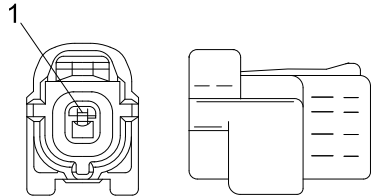
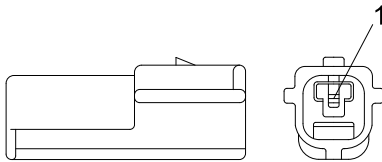
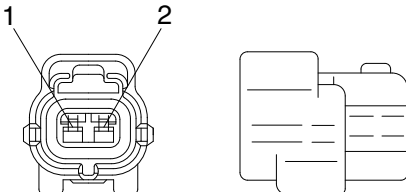
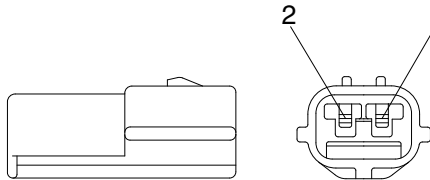
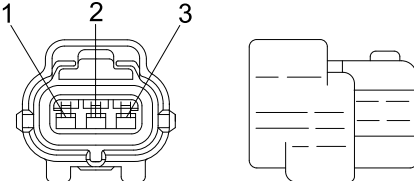
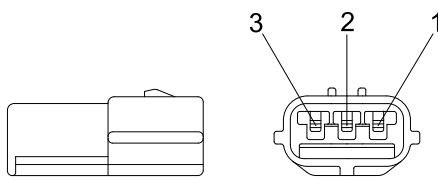
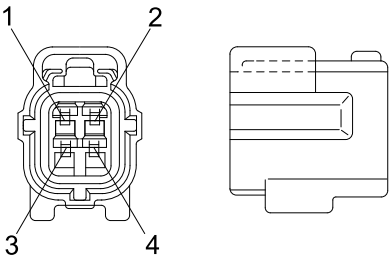
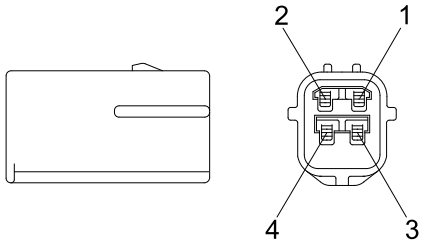
No. of pin	Receptacle connector (female)	Plug connector (male)
1	 <p style="text-align: center;">S816-001002</p>	 <p style="text-align: center;">S816-101002</p>
2	 <p style="text-align: center;">S816-002002</p>	 <p style="text-align: center;">S816-102002</p>
3	 <p style="text-align: center;">S816-003002</p>	 <p style="text-align: center;">S816-103002</p>
4	 <p style="text-align: center;">S816-004002</p>	 <p style="text-align: center;">S816-104002</p>

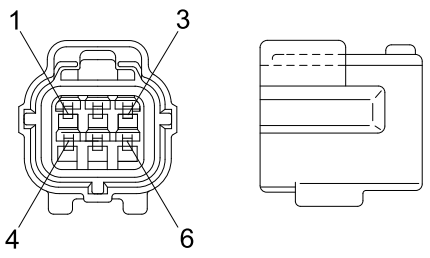
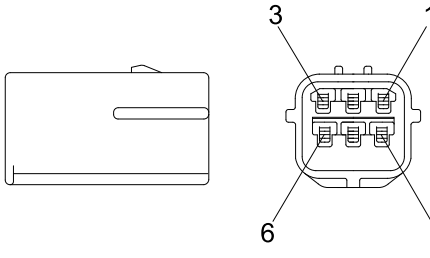
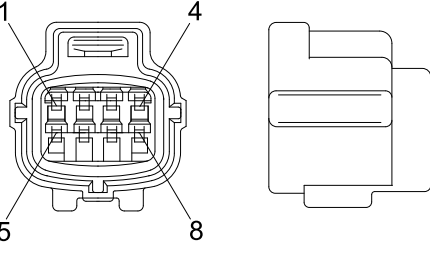
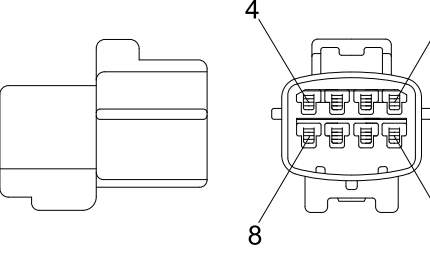
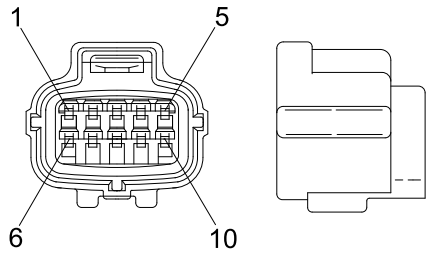
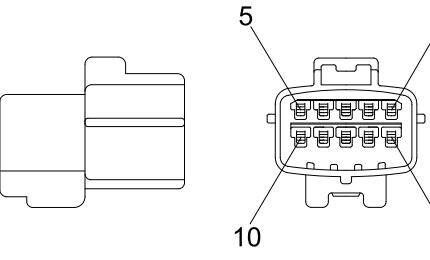
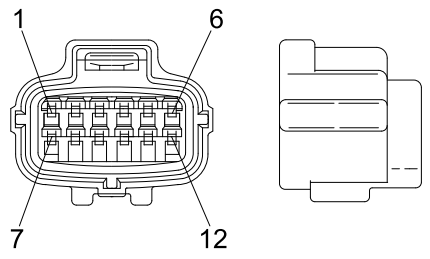
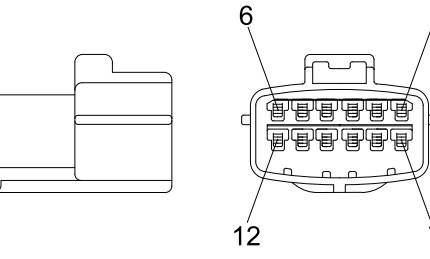
No. of pin	Receptacle connector (female)	Plug connector (male)
6	 <p data-bbox="686 638 837 672">S816-006002</p>	 <p data-bbox="1244 638 1396 672">S816-106002</p>
8	 <p data-bbox="686 1041 837 1075">S816-008002</p>	 <p data-bbox="1244 1041 1396 1075">S816-108002</p>
10	 <p data-bbox="686 1444 837 1478">S816-010002</p>	 <p data-bbox="1244 1444 1396 1478">S816-110002</p>
12	 <p data-bbox="686 1848 837 1881">S816-012002</p>	 <p data-bbox="1244 1848 1396 1881">S816-112002</p>

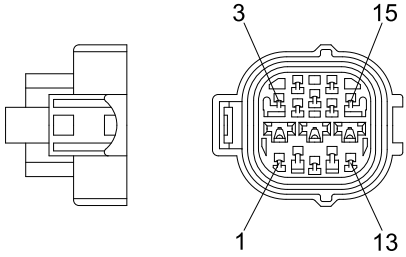
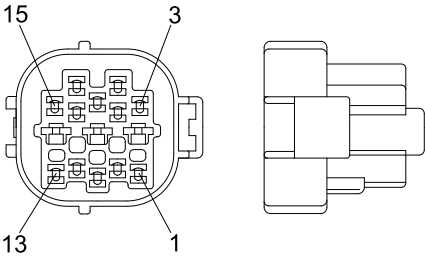
No. of pin	Receptacle connector (female)	Plug connector (male)
15	 <p data-bbox="730 636 836 667">368301-1</p>	 <p data-bbox="1278 636 1383 667">2-85262-1</p>

19) METRI-PACK TYPE CONNECTOR

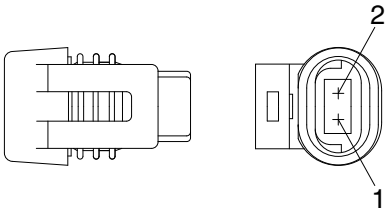
No. of pin	Receptacle connector (female)	Plug connector (male)
2	 <p data-bbox="724 1240 829 1272">12040753</p>	

20) DEUTSCH HD30 CONNECTOR

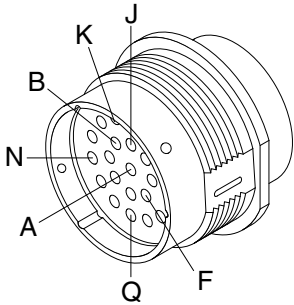
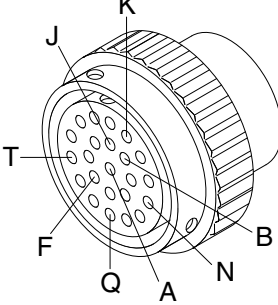
No. of pin	Receptacle connector (female)	Plug connector (male)
23	 <p data-bbox="667 1841 834 1872">HD36-24-23SN</p>	 <p data-bbox="1225 1841 1393 1872">HD34-24-23PN</p>

21) DEUTSCH MCU CONNECTOR

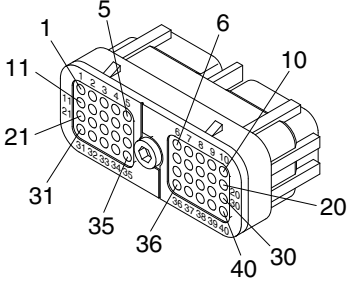
No. of pin	Receptacle connector (female)	Plug connector (male)
40	 <p style="text-align: right;">DRC26-40SA/B</p>	

22) DEUTSCH SERVICE TOOL CONNECTOR

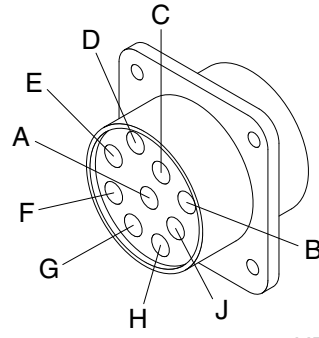
No. of pin	Receptacle connector (female)	Plug connector (male)
9	 <p style="text-align: right;">HD10-9-96P</p>	

23) AMP FUEL WARMER CONNECTOR

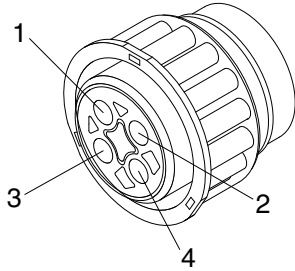
No. of pin	Receptacle connector (female)	Plug connector (male)
4	 <p style="text-align: right;">2-967325-3</p>	

24) DEUTSCH ENGINE ECM CONNECTOR

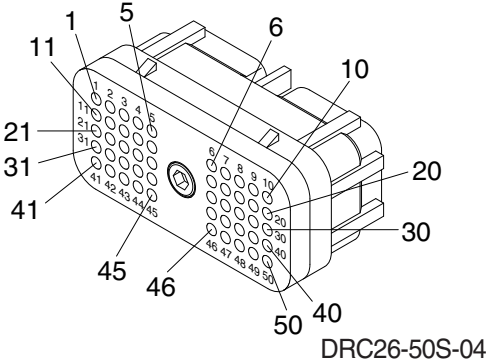
No. of pin	Receptacle connector (female)	Plug connector (male)
50	 <p style="text-align: right;">DRC26-50S-04</p>	

25) DEUTSCH INTERMEDIATE CONNECTOR

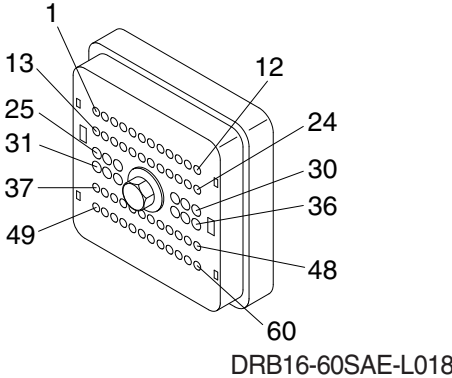
No. of pin	Receptacle connector (female)	Plug connector (male)
60	 <p style="text-align: right;">DRB16-60SAE-L018</p>	