

SERVICE MANUAL

# SERVICE MANUAL

MOVING YOU FURTHER

HW100A

EXCAVATOR  
**HW100A**

 **HYUNDAI**  
CONSTRUCTION EQUIPMENT

PART NO. : 950106-03091A-EN  
Printed in Korea

HYUNDAI

 **HYUNDAI**  
CONSTRUCTION EQUIPMENT







# Table of Contents

## Safety, Specification and Systems Operation

### 1 Safety

1 Track Excavator Maintenance Safety

### 2 Specifications

1 General - Specifications

2 Engine - Specifications

3 Hydraulic Systems and Structure - Specifications

### 3 General Maintenance

1 General Maintenance Instructions

2 Standard Torques

### 4 Engine

1 Engine

### 5 Hydraulic Systems and Components

1 Systems Operation, Description and Inspection

2 Components Operation, Description and Inspection

### 6 Electrical Systems

1 Systems Operation and Description

## Removal and Installation

### 1 Removal and Installation

1 Engine

2 Hydraulic Systems

3 Electric and Electronic

# Troubleshooting Guide

## 1 Troubleshooting

- 1 Wiring Harness Layout
- 2 Error Code

## 2 Schematic

- 1 Hydraulic Schematic
- 2 Electrical Schematic

# Safety, Specification and Systems Operation









# Wheel Excavator Maintenance Safety

# Safety Instructions

---

## **WARNING**

---

### AVOID DEATH OR SERIOUS INJURY

Instructions are necessary before operating or servicing machine. Read and understand the Operation & Maintenance Manual and signs (decals) on machine. Follow warnings and instructions in the manuals when making repairs, adjustments or servicing. Check for correct function after adjustments repairs or service. Untrained operators and failure to follow instructions can cause death or serious injury.

---

# Table of Contents

## Wheel Excavator Maintenance Safety

Safety Instructions .....	6
Safety Messages .....	9
General .....	10
Safe Operation is Operator's Responsibility .....	10
Know Your Machine .....	10
Proper Work Tools and Attachments .....	10
Pressurized Fluids .....	11
Flying or Falling Objects .....	12
Personal Protective Equipment (PPE) .....	12
Correction of Machine Problems .....	12
Crushing and Cutting .....	12
Hot Coolant and Oils - Burn Prevention .....	13
Fire and Explosion Prevention .....	14
Fire Extinguisher and First-Aid Kit (Emergency Medical Kit)	
17	
Electrical System and Electrical Shock .....	17
Roll-over Protective Structure (ROPS) .....	17
Maintenance .....	20
Warning Tag .....	22
Cleaning .....	23
Proper Tools and Clothing .....	23
Disassembling Precautions .....	23
Use of Lighting .....	23
Fire and Explosion Prevention .....	24
Burn Prevention .....	24
Rubber That Contains Fluorides .....	25
Rubber and Plastics .....	25
Welding Repairs .....	26
Warning for Counterweight and Front Attachment Removal	
28	
Lock Inspection Covers .....	28
Working on Machine .....	28
Accumulator .....	29
Compressed Air .....	29
Supports and Blocking for Work Equipment .....	29
High-pressure Lines, Tubes and Hoses .....	30
Battery .....	31
Environment and Circumstances .....	33

Work Site Areas Requiring Extra Caution . . . . .	33
High-voltage Cables . . . . .	35
Underground Operation . . . . .	35
Working in Water. . . . .	36
Working in Contaminated Environment. . . . .	36
Operation in Extreme Conditions . . . . .	36
Exhaust Ventilation . . . . .	40
Asbestos Information . . . . .	41
Silica Dust Information . . . . .	41
Disposal of Hazardous Materials . . . . .	42
Sound . . . . .	42
Vibration Information . . . . .	42
Operation . . . . .	45
Before Engine Starting . . . . .	45
Work Site. . . . .	45
Mounting/Dismounting . . . . .	46
Cleaning . . . . .	46
Operator Station . . . . .	47
Seat Belt . . . . .	47
Visibility Information . . . . .	48
Boost Starting or Charging Battery . . . . .	52
Starting Engine . . . . .	52
Swinging or Traveling . . . . .	53
Lifting and Digging . . . . .	55
Operation on Slopes . . . . .	56
Towing. . . . .	57
Attachment . . . . .	58
Equipment Lowering with Engine Stopped . . . . .	58
Engine Stop. . . . .	58
Parking Machine . . . . .	59
Service Brake . . . . .	60
Preservation/Storing Machine. . . . .	60
Transportation . . . . .	62
Obey State and Local Over-the-Road Regulations. . . . .	62
Loading and Unloading . . . . .	62
Transporting Machine . . . . .	63

## Safety Messages

There are several specific safety messages on this machine. The exact location of the hazards and the description of the hazards are reviewed in this section. Please become familiarized with all safety messages.

Make sure that all the safety messages are legible.

Clean the safety messages or replace the safety messages if you cannot read the words. Replace the illustrations if the illustrations are not visible. When you clean the safety messages, use a cloth, water, and soap. Do not use solvent, gasoline, or other harsh chemicals to clean the safety messages. Solvents, gasoline, or harsh chemicals could loosen the adhesive that secures the safety message. Loose adhesive will allow the safety message to fall.

Replace any safety message that is damaged, or missing. If a safety message is attached to a part that is replaced, install a safety message on the replacement part.

# General

## Safe Operation is Operator's Responsibility

Only trained and authorized personnel should operate and maintain the machine.

Follow all safety rules, regulations and instructions when operating or performing maintenance on machine.

- Do not operate machine if you are under the influence of drugs or alcohol. An operator who is taking prescription drugs must get medical advice to determine if he or she can safely operate a machine.
- When working with other personnel on a work site, be sure that all personnel know nature of work and understand all hand signals that are to be used.
- Be sure that all guards and shields are installed in their proper location. Have guards and shields repaired or replaced immediately if damaged.
- Be sure that you understand the use and maintenance of all safety features such as safety lock lever and seat belt. Use them properly.
- Never remove, modify or disable any safety features. Always keep them in good operating condition.
- Always check for and know the location of underground and overhead utility lines before excavating.
- Failure to use and maintain safety features according to instructions in this manual, Safety Manual and Shop Manual can result in death or serious injury.

## Know Your Machine

Know how to operate your machine. Know the purpose of all controls, gauges, signals, indicators and monitor displays. Know the rated load capacity, speed range, braking and steering characteristics, turning radius and operating clearances. Keep in mind that rain, snow, ice, loose gravel, soft ground, slopes etc., can change operating capabilities of your machine.

## Proper Work Tools and Attachments

Only use work tools and attachments that are recommended by HYUNDAI for use on HYUNDAI machines. When installing and using optional attachments, read instruction manual for attachment, and general information related to attachments in this manual. Because HYUNDAI cannot anticipate, identify or test all attachments that owners may want to install on their machines, contact HYUNDAI for written authorization and approval of attachments, and their compatibility with optional kits.



Attachments and attachment control systems that are compatible with the machine are required for safe and reliable machine operation. Do not exceed maximum operating weight (machine weight plus attachment) that is listed on ROPS certification plate.

Make sure that all guards and shields are in place on machine and on work tool. Depending on type or combination of work equipment, there is a potential that work equipment could interfere with the cabin or other parts of machine. Before using unfamiliar work equipment, check if there is any potential of interference, and operate with caution.

While you are performing any maintenance, testing, or adjustments to attachments, stay clear of the following areas: cutting edges, pinch points, and crushing surfaces.

Never use attachment as a work platform or manlift.

Contact your HYUNDAI distributor about auxiliary hydraulic kits for attachments installation. If you are in doubt about compatibility of a particular attachment with a machine, consult your HYUNDAI distributor.

## Pressurized Fluids

Pressurized air or fluids can cause debris and/or fluids to be blown out. This could result in death or serious injury.

Immediately after operations are stopped, coolant, engine oil, and hydraulic oil are at their highest temperatures and the radiator and hydraulic tank are still under pressure. Always wait for temperature to cool down. Follow specified procedures when attempting to remove caps, drain oil or coolant, or replacing filters. Always wait for temperature to cool down, and follow specified procedures when performing these operations. Failure to do so can result in death or serious injury.

When pressurized air and/or pressurized water is used for cleaning, wear protective clothing, protective shoes, and eye protection. Eye protection includes goggles or a protective face shield.

Pressure can be trapped in a hydraulic system and must be relieved before maintenance is started.

Releasing trapped pressure can cause sudden machine movement or attachment movement. Use caution if you disconnect hydraulic lines or fittings.

High-pressure oil that is released can cause a hose to whip or oil to spray. Fluid penetration can result in death or serious injury. If fluid enters skin or eyes, get immediate medical attention from a physician familiar with this injury.

Obey all local laws and regulations for disposal of liquids.

To prevent hot coolant from spraying out, stop engine and wait for coolant to cool. Using gloves, slowly loosen cap to relieve pressure.

Figure 1

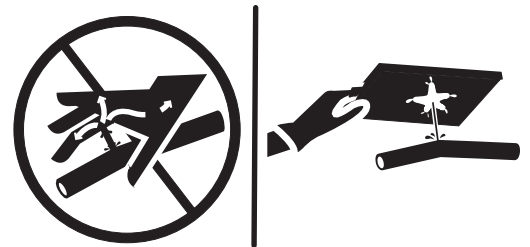

FG018457

## Flying or Falling Objects

On work sites where there is a potential hazard that flying or falling objects can hit operator's cabin, select and use a guard to match operating conditions for additional operator protection.

Working in mines, tunnels, deep pits, and loose or wet surfaces, could produce hazard of falling rocks or flying objects. Additional protection for operator's cabin could be required such as an Operator Protection Guard (OPG) or window guards. Contact your HYUNDAI distributor for information on available protective guards.

To prevent personnel from being struck by flying objects, keep personnel out of work area.

Figure 2

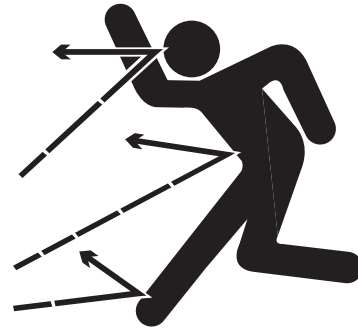

HAQA110L

Figure 3



HAQA100L

## Personal Protective Equipment (PPE)

Do not wear loose clothing and accessories. Secure long hair. These items can snag on controls or on other parts of equipment.

Do not wear oily clothes. They are highly flammable.

Do not forget that some risks to your health may not be immediately apparent. Exhaust gases and noise pollution may not be visible, but these hazards can cause disabling or permanent injuries. Breathing masks and/or ear protection may be required.

Wear a hard hat, safety shoes, safety goggles, mask, leather gloves, earplugs and other protective equipment, as required.

While working on machine, never use inadequate tools. They could break or slip, or they may not adequately perform intended functions.

Figure 4



HAQA020L

## Correction of Machine Problems

If any machine problems are found during operation and maintenance (noise, vibration, smell, incorrect gauges, smoke, oil leakage, etc.), or if any abnormal warning alerts are displayed on display monitor, stop the machine and take the necessary corrective actions. Do not operate machine until problem has been corrected.

## Crushing and Cutting

Keep objects away from moving fan blades. Fan blades can throw and cut objects.

Do not use a wire rope that is kinked or frayed, or a wire rope with any loss of diameter. Wear leather gloves when handling a wire rope.

When striking a loose retainer pin, it can fly out and can cause a serious injury. Make sure that area is clear of personnel when striking a retainer pin. To avoid injury to your eyes, wear safety goggles when striking a retainer pin.

Do not put your hand, arm or any other part of your body between movable parts. If going between movable parts is necessary, always position and secure work equipment so it cannot move. Properly support equipment before performing any work or maintenance under raised equipment.

If control levers are operated, clearance between machine and work equipment will change and this may lead to serious damage or can result in death or serious injury. Stay clear of areas that may have a sudden change in clearance with machine movement or equipment movement. Stay clear of all rotating and moving parts. Unless instructed, never attempt adjustments while machine is moving or while engine is running.

Do not depend on hydraulic cylinders to support raised equipment. Equipment can fall if a control is moved, or if a hydraulic line breaks, is loosened or disconnected.

If it is necessary to remove guards to perform maintenance, always install guards after maintenance is completed.

**Figure 5**



HDO1010L

## Hot Coolant and Oils - Burn Prevention

Do not touch any part of an operating engine. Immediately after operations are stopped, coolant, engine oil, and hydraulic oil are at their highest temperatures. The radiator and hydraulic tank are still under pressure. Always wait for temperature to cool down. Attempting to remove caps, drain oil or coolant, or replacing filters may lead to serious burns, if done when hot. Relieve all pressure in air system, hydraulic oil system, lubrication system, fuel system, and cooling system, before any lines, fittings or related items are disconnected.

**Figure 6**



FG019095

To prevent hot oil or coolant from spraying out, stop engine, wait for oil and coolant to cool. Using gloves, slowly loosen cap to relieve pressure.

Figure 7



FG019096

## Fire and Explosion Prevention

All fuels, most lubricants and some coolant mixtures are flammable and can cause a fire resulting in death or serious injury, and property damage. Flammable fluids that are leaking or spilled onto hot surfaces or onto electrical components can cause fire.

Inspect for and remove all flammable materials such as spilled fuel and oil, and debris from machine. Do not allow any flammable materials to accumulate on machine.

Always observe the following:

- Add fuel, oil, antifreeze and hydraulic fluid to machine only in a well ventilated area. Machine must be parked with controls, lights and switches turned "OFF". Engine must be "OFF" and any flames, glowing embers, auxiliary heating units or spark causing equipment must be extinguished, or turned "OFF" and kept well clear of machine.
- Dust that is generated from repairing or grinding nonmetallic hoods or nonmetallic fenders can be toxic, flammable and explosive. Repair these components in a well ventilated area away from flames or sparks and wear dust mask when grinding painted parts.

## Maintenance

The machine and some attachments have components that are at high temperatures under normal operating conditions. The primary source of high temperatures are the engine and exhaust system. If damaged or incorrectly maintained, the electrical system can be a source of arcs or sparks.

Flammable debris (leaves, straw, etc.) must be removed regularly. If flammable debris is allowed to accumulate, it can cause a fire hazard. Clean machine often to avoid this accumulation. Flammable debris in an engine compartment is a potential fire hazard.

The operator's area, engine compartment and engine cooling system must be inspected every day and cleaned. This is necessary to prevent fire hazards and overheating.

Figure 8



H D O 1 C

Figure 9



FG018458

## Operation

Do not use machine where exhaust, arcs, sparks or hot components can contact flammable material, explosive dust or gases.

Do not operate machine near any flame.

Exhaust shields (if equipped) protect hot exhaust components from oil spray or fuel spray in case of a break in a line, hose, or seal. Exhaust shields must be correctly installed.

## Electrical

Check all electrical wiring and connections for damage daily.

Keep battery terminals clean and tight. Repair or replace any damaged part or wires that are loose or frayed. Clean all electrical connections and tighten all electrical connections.

Never check battery charge by placing a metal object across terminal posts. Use a voltmeter or a hydrometer.

Battery gas can explode and can result in death or serious injury. Follow procedures in this manual for connecting battery and for jump-starting. Do not jump-start or charge a frozen or damaged battery. Keep any flames or sparks away from batteries. Do not smoke in battery charging area.

Improper jumper cable connections can cause an explosion that can result in death or serious injury. Refer to "Starting Engine With a Booster Cable" for more information.

Do not charge a frozen battery. This can cause an explosion.

After market radios or other electric operated equipment in cabin must have a fuse in the electrical circuit.

## Hydraulic System

Check hydraulic tubes, hoses and fittings for damage, wear or for leaks. Hydraulic lines and hoses must be properly routed and have adequate support and secure clamps. Leaks can cause fires. Never use a flame or bare skin to check for leaks.

Tighten or replace any parts that show leakage.

Check that all hose and tube clamps, guards, and cushions are securely attached. If they are loose, they can vibrate during operation and rub against other parts. This can cause damage to hoses and cause high-pressure oil to spray on hot surfaces, causing a fire and death or serious injury.

Always clean fluid spills. Do not use gasoline or diesel fuel for cleaning parts. Use commercial nonflammable solvents.

Figure 10

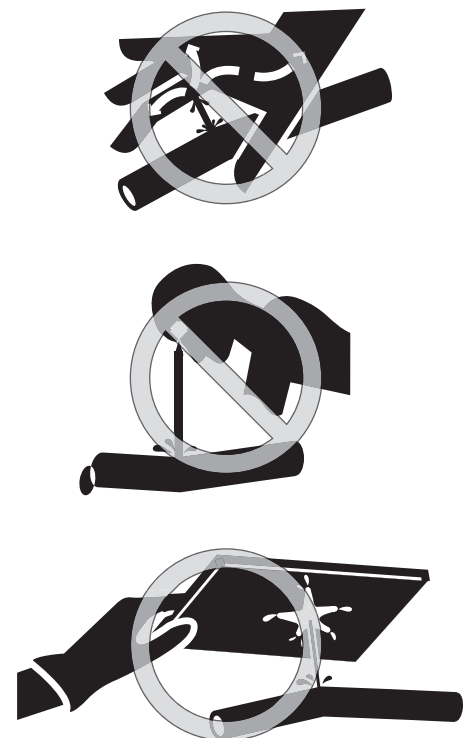

EX1400129

## Fueling

Use caution when you are refueling a machine.

Fuel is flammable and can catch fire if it is brought close to a flame.

Stop engine and let it cool before adding fuel. Do not smoke while you are refueling a machine. Do not refuel a machine near flames or sparks. Fill fuel tank outdoors.

Keep fuel and other fluid reservoir caps tight and do not start engine until caps have been secured.

Store fuels and lubricants in properly marked containers away from unauthorized personnel. Store oily rags and any flammable materials in protective containers.

Static electricity can produce dangerous sparks at fuel filling nozzle. In very cold, dry weather or other conditions that could produce a static discharge, keep tip of fuel nozzle in constant contact with neck of fuel filling nozzle, to provide a ground.

Always place plastic fuel containers on the ground before filling.

## Never Use Ether Starting Aids

Do not use ether or starting fluids on any engine that has glow plugs, or an electric grid type manifold heater. These starting aids can cause an explosion and result in death or serious injury.

Use procedures in this manual for connecting battery and for jump-starting.

## Welding and Grinding

Always clean machine and attachment, set battery disconnect switch to "OFF" position, and disconnect wiring from electronic controllers before welding. Cover rubber hoses, battery and all other flammable parts. Keep a fire extinguisher near machine when welding.

Toxic dust or gas can be produced when grinding or welding painted parts. Grinding or welding painted parts must be done in a well ventilated area. Wear dust mask when grinding painted parts.

Dust generated from repairing nonmetallic parts such as hoods, fenders or covers can be flammable or explosive.

Repair such components in a well ventilated area away from flames or sparks.

Do not weld on lines or on tanks that contain flammable fluids. Do not flame cut lines or tanks that contain flammable fluid. Clean any such lines or tanks thoroughly with a nonflammable solvent before welding or flame cutting.

Figure 11



Figure 12



## If a Fire Occurs

If a fire occurs:

- Do not attempt to move machine or continue operations.
- Turn starter switch to "O" (OFF) position to stop engine.
- Use handrails and steps to get off machine.
- Immediately call a fire department for help.
- When using a fire extinguisher, always aim extinguisher at base of fire.
- If an optional fire extinguishing system is in place, be familiar with its operating procedures.

**NOTE:** Depending on job conditions, other procedures could be necessary if a fire occurs.

## Fire Extinguisher and First-Aid Kit (Emergency Medical Kit)

To be prepared in the event of a fire:

- Be sure that fire extinguishers have been provided and read labels to ensure that you know how to use them. It is recommended that an appropriately sized (2.27 kg [5 lb] or larger) multipurpose A/B/C fire extinguisher be mounted in cabin. Check and service fire extinguisher at regular intervals and make sure that all work site crew members are adequately trained in its use.
- Inspect fire extinguisher and service fire extinguisher regularly.
- Follow instructions on extinguisher instruction plate.
- Keep a first aid kit inside the cabin and keep another kit at work site. Check kit periodically and keep it properly supplied.
- Keep emergency numbers for doctor, ambulance service, hospital and fire department readily available.

## Electrical System and Electrical Shock

Never short across starter terminals or across batteries. Shorting could damage electrical system and engine neutral start system.

When engine is running or immediately after it has stopped, high voltage is generated at injector terminal and inside engine controller, so there is a potential for an electrical shock. Never touch injector terminal or inside of engine controller.

**NOTE:** If it is necessary to touch injector terminal or inside engine controller, contact your HYUNDAI distributor.

## Roll-over Protective Structure (ROPS)

The operator's cabin is a ROPS certified structure for protecting the seat-belted operator. It absorbs the impact energy of a

Figure 13



FG018459

Figure 14



HDO1009L

Figure 15

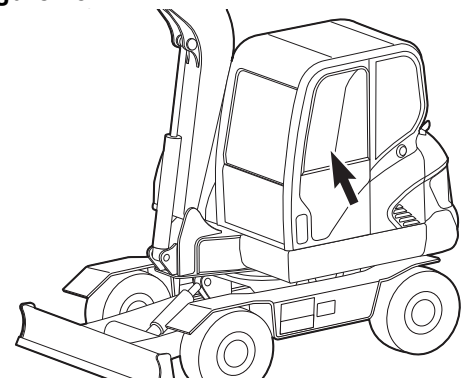

WE1500714

roll-over impact. Do not allow machine weight (mass) to exceed certified value on certification plate. If weight is exceeded, the ROPS structure will not be able to fulfill its safety function.

Do not increase machine weight beyond certified value by modifying machine or by installing attachments on machine. If weight limit of protective equipment is exceeded, protective equipment will not be able to protect operator, and this can result in death or serious injury. Always observe the following:

- This machine is equipped with a protective structure. Do not remove protective structure and perform operations without it.
- Never modify the operator's cabin by welding, grinding, drilling holes or adding attachments unless instructed by HYUNDAI in writing. Changes to the cabin can cause loss of operator protection from roll-over and falling objects, and result in death or serious injury.
- When protective structure is damaged or deformed by falling objects or by rolling over, its strength will be reduced and it will not be able to adequately protect the operator. Contact your HYUNDAI distributor if you have any questions about the ROPS. Never repair a damaged ROPS cabin.
- Always wear your seat belt when operating machine.

#### ROPS Certification

This HYUNDAI excavator has an operator's cabin that meets ROPS requirements. The seat belt must be worn for roll-over protection.

The ROPS certification plate is found on the left side of the cabin on most models. It may vary slightly in its location on some models.

Check the ROPS cabin, mounting, and hardware for damage.

Never modify the ROPS cabin. Replace the cabin and hardware if damaged. See your HYUNDAI distributor for parts.

Figure 16

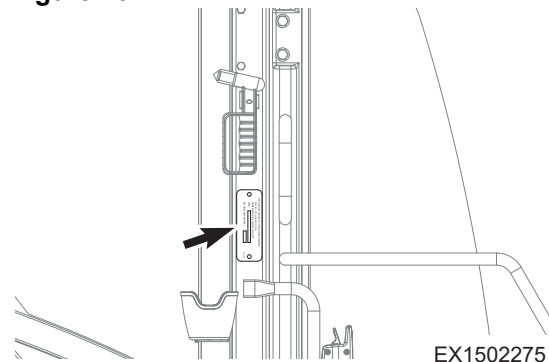

---

## WARNING

---

### AVOID DEATH OR SERIOUS INJURY

Never modify the operator cabin by welding, grinding, drilling holes or adding attachments unless instructed in writing by HYUNDAI. Changes to the cabin can cause loss of operator protection from roll-over and falling objects, and can result in death or serious injury.

---



### Protecting Cabin from Flying or Falling Objects (If Equipped)

The roof guard (1) is available for applications where the risk of small falling objects exists.

The guard is applied to the upper side of the cabin to protect the operator and prevent damage to the glass roof from small falling objects (gravel, sand, etc.).

When working in mines, quarries or other work sites where there is a hazard of falling rocks, install Operator Protection Guard (OPG) (2) and apply a laminated coating sheet to front glass.

Figure 17

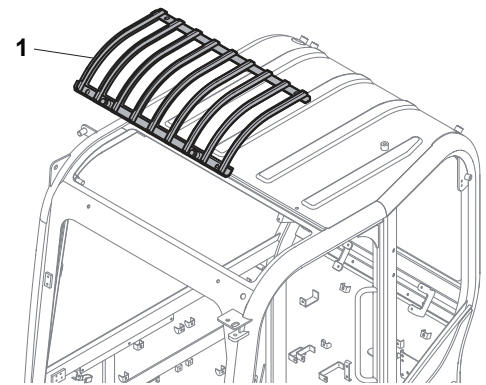

WE1500911

When OPG is installed, and front window needs to be cleaned, loosen bolts marked with arrows. Be sure to tighten bolts when done.

Never attempt to alter or modify any protective structure reinforcement system, by drilling holes, welding, remounting or relocating fasteners. Any serious impact or damage to system requires a complete inspection of the structure. Reinstallation, recertification and/or replacement of system may be necessary.

Contact your HYUNDAI distributor for available safety guards and/or recommendations to protect against objects that could strike operator's cabin. Make sure that all other work site crew members are kept away from excavator when operating.

If any glass on machine is broken, replace it with new glass immediately.

**NOTE:** *The preceding instructions assume that conditions are for standard operations, but it may be necessary to add additional guards depending on operating conditions or local rules or regulations for the work site. Always contact your HYUNDAI distributor for advice.*

Figure 18

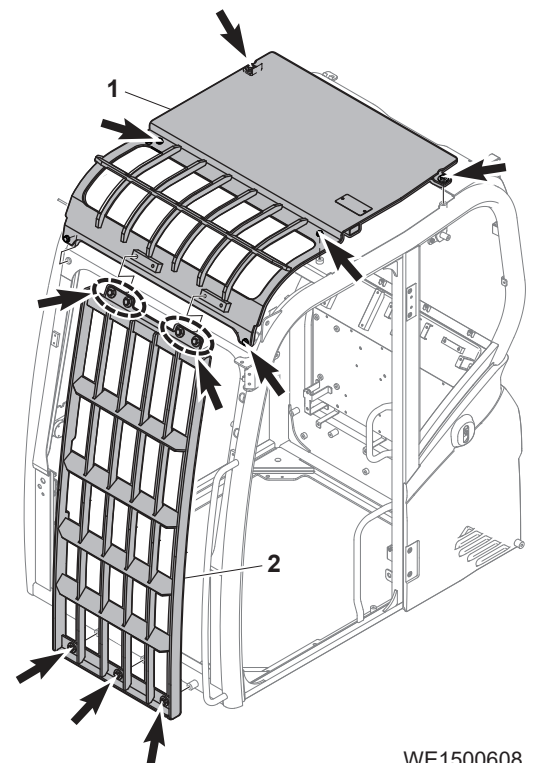

WE1500608

### Emergency Exit from Operator's Station

This machine is equipped with a glass breaking tool. It is found on left pillar of cabin. This tool can be used to break the glass to exit from cabin in an emergency. Grip handle firmly and use sharp point to break glass.

- Be careful also not to slip on broken pieces of glass on ground.

Figure 19

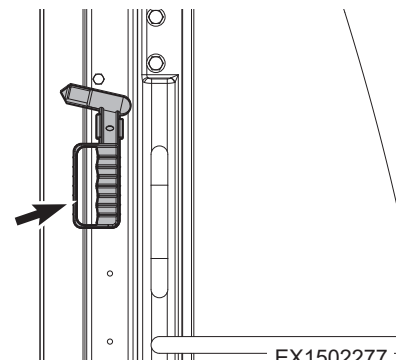

EX1502277

---

## **WARNING**

---

AVOID DEATH OR SERIOUS INJURY  
Protect your eyes when breaking the glass.

---

# Maintenance

Improper operation and maintenance can result in death or serious injury. Read manual and safety decals before operating or maintaining the machine. Follow all instructions and safety messages.

---

## **WARNING**

---

### AVOID DEATH OR SERIOUS INJURY

Follow instructions before operating or servicing machine. Read and understand the Operation & Maintenance Manual and signs (decals) on machine. Follow warnings and instructions in the manuals when making repairs, adjustments or servicing. Check for correct function after adjustments, repairs or service. Untrained operators and failure to follow instructions can result in death or serious injury.

---

- Never service HYUNDAI equipment without instructions.
- Always lower bucket and blade to ground before doing any maintenance.
- Use correct procedure to lift and support excavator.
- Cleaning and maintenance are required daily.
- Welding or grinding painted parts must be done in well ventilated areas.
- Wear a dust mask when grinding painted parts. Toxic dust and gas can be produced.
- Vent exhaust to outside when engine must be running for service.
- Exhaust system must be tightly sealed. Exhaust fumes are hazardous and can cause death or serious injury.
- Stop and allow engine to cool and clean engine of flammable materials before checking fluids.
- Never service or adjust machine with engine running unless instructed to do so in this manual.
- Avoid contact with leaking hydraulic fluid or diesel fuel under pressure. It can penetrate skin or eyes.
- Never fill fuel tank while engine running, while smoking, or when near open flame.
- Keep body, jewelry and clothing away from moving parts, electrical contact, hot parts and exhaust.
- Wear eye protection to guard from battery acid, compressed springs, fluids under pressure and flying debris when engines

are running or tools are used. Use eye protection approved for welding.

- Lead-acid batteries produce flammable and explosive gases.
- Keep arcs, sparks, flames and lighted tobacco away from batteries.
- Batteries contain acid which burns eyes or skin on contact.
- Wear protective clothing. If acid contacts body, flush well with water. For eye contact flush well and get immediate medical attention from a physician familiar with this injury.
- The maintenance procedures which are given in this manual can be performed by the owner or operator without any specific technical training. Maintenance procedures which are not in this manual must be performed **ONLY BY QUALIFIED SERVICE PERSONNEL**. Always use genuine **HYUNDAI** replacement parts.
- Only authorized personnel should service and repair the machine. Do not allow unauthorized personnel into work area.
- Lower work equipment and stop engine before performing maintenance.
- Park machine on firm and level ground.
- Turn starter switch to "ON" position and keep safety lever in "UNLOCK" position. Cycle work levers (joysticks) back and forth, left and right at full stroke 2 to 3 times to eliminate remaining internal pressure in hydraulic circuit. Then move safety lever to "LOCK" position.
- Check that battery relay is "OFF" and main power is shut off. (Wait for approximately one minute after turning "OFF" engine starter switch key and press horn switch. If horn does not sound, the main power is shut off.)
- Put blocks under tires to prevent the machine from moving.
- To prevent injury, do not perform maintenance with engine running. If maintenance must be done with engine running, perform maintenance with at least two workers and do the following:
  - One worker must always sit in the operator's seat and be ready to stop engine at any time. All workers must maintain contact with other workers.
  - When maintenance operations are near fan, fan belt, or other rotating parts, there is a potential hazard of being caught in rotating parts. Keep hands and tools away.
- Never drop or insert tools or other objects into rotating fan or fan belt. Parts can break off and hit someone.

- Do not touch any control levers or control pedals. If any control levers or control pedals must be operated, always give a signal to other workers and instruct them to move away.
- When performing maintenance of engine and you are exposed to engine noise for long periods of time, wear hearing protection while working.
- If noise from the machine is too loud, it can cause temporary or permanent hearing problems.
- Do not smoke when you service an air conditioner or if refrigerant gas is present.
- Inhaling fumes either from a flame or gas from a cigarette that has contacted air conditioner refrigerant can cause death or serious injury.
- Never put maintenance fluids into glass containers. Drain all liquids into a suitable containers.
- Unless instructed otherwise, perform maintenance with equipment in servicing position. Refer to this manual for procedure for placing equipment in servicing position.

## Warning Tag

Alert others that service or maintenance is being performed by attaching a "DO NOT OPERATE" warning tag to the operator's cabin controls—and the machine areas, if required. Use of a chain or cable to keep the safety lock lever in the fully lowered "LOCK" position, complies with OSHA's lockout requirements.

"DO NOT OPERATE" warning tags, are available from your HYUNDAI distributor.

- Always attach "DO NOT OPERATE" warning tag to work equipment control lever in the operator's cabin to alert others that you are performing service or maintenance on the machine. Attach additional warning tags on the machine, if necessary.

Keep warning tags in tool box while it is not used. If there is not a tool box, then keep them in the owner manual storage pocket.

- If any other person starts engine, and operates control levers or control pedals while you are performing service or maintenance, it can result in death or serious injury.

Attach a "DO NOT OPERATE" warning tag to starter switch or to controls before servicing or repairing equipment. Warning tags are available from your HYUNDAI distributor.

Figure 20



DS1801807

## Cleaning

Clean machine before performing inspection and maintenance.

If inspection and maintenance are done when machine is dirty, it will become more difficult to locate problems, and you could slip on steps and work platform areas and injure yourself.

When washing machine, do the following:

- Wear shoes with nonslip soles to prevent slipping and falling.
- Wear safety goggles and protective clothing when washing machine with high-pressure steam or water.
- Do not spray water directly on electrical components (sensors, connectors). If water gets into electrical system, it can cause operation problems.
- Pick up any tools or hammers that are laying in workplace. Wipe up any grease or oil to prevent slippery substances, that can cause tripping or slipping.
- When cleaning cabin top window which is made of polycarbonate material, use tap water. Avoid use of organic solvents for cleaning, such as benzene, toluene or methanol. These solvents can cause a chemical reaction that will dissolve and damage the window.

Figure 21

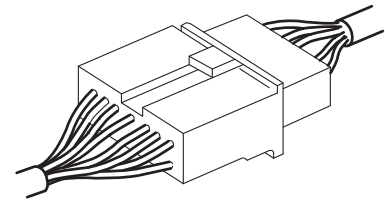
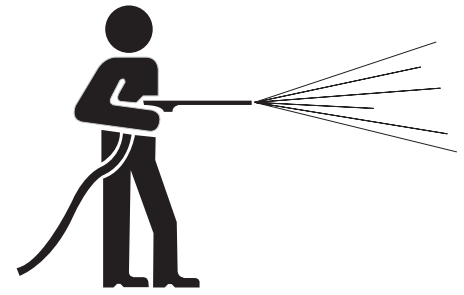

ARO1330L

## Proper Tools and Clothing

Only use tools that are intended for the type of service to be done. Metal pieces from low quality or damaged tools, such as chisels or hammers, can break off and hit a service person in the eyes or face causing serious injury.

## Disassembling Precautions

When using a hammer to remove pins, pins can fly out or metal particles may break off. Always do the following:

- Hitting hard metal pins, bucket teeth, cutting edges or bearings with a hammer, can cause metal pieces to break or fly off resulting in serious injury. Always wear safety goggles and leather gloves. Keep other personnel away.

## Use of Lighting

When checking fuel, oil, battery electrolyte, window washer fluid, or coolant, always use proper lighting equipment to prevent arcs or sparks that could cause a fire or explosion resulting in death or serious injury.

## Fire and Explosion Prevention

Fuels, most lubricants and some coolant mixtures are flammable. Flammable fluids that are leaking or spilled onto hot surfaces or onto electrical components can cause a fire resulting in property damage or death or serious injury.

Store all fuels and all lubricants in properly marked and approved containers and keep away from all unauthorized personnel.

Store oily rags and other flammable material in a protective container.

Tighten all fuel and oil caps.

Do not smoke while you refuel machine or while you are in a refueling area.

Do not smoke in battery charging areas or in areas that contain flammable material.

Clean all electrical connections and tighten all electrical connections. Check electrical wires daily for wires that are loose or frayed. Tighten all loose, and repair or replace all frayed, electrical wires before operating machine.

Remove all flammable materials and debris from the engine compartment, exhaust system components and hydraulic lines.

## Burn Prevention

When checking radiator coolant level, stop engine, let engine and radiator cool down, then check coolant recovery tank. If coolant level in coolant recovery tank is near upper limit, there is enough coolant in radiator.

Using gloves, loosen radiator cap slowly to release internal pressure before removing radiator cap.

If coolant level in coolant recovery tank is below lower limit, add coolant.

Cooling system conditioner contains alkali which can cause personal injury. Do not allow alkali to contact skin, eyes, or mouth.

Allow cooling system components to cool before draining cooling system.

Hot oil and hot components can cause personal injury. Do not allow hot oil or hot components to contact skin.

Vent hydraulic tank only after engine has been stopped and hydraulic tank is cool. Using gloves, slowly tilt hydraulic tank air breather to relieve pressure.

Relieve all pressure in hydraulic oil system, in fuel system, or in cooling system before disconnecting any lines, hoses, fittings, or related components.

Batteries give off flammable fumes that can explode and start a fire.

Do not smoke while you are checking battery electrolyte level.

Figure 22



H D O 1 C

Figure 23



FG018458

Figure 24

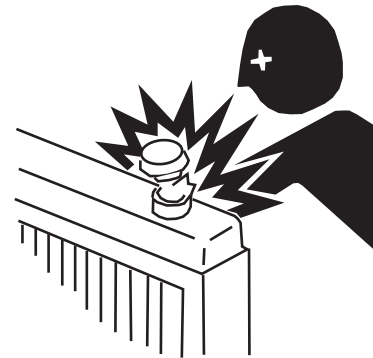

haae2090

Electrolyte is an acid. Electrolyte can cause personal injury. Do not allow electrolyte to contact skin or eyes.

Always wear safety goggles and face protection when working with batteries.

## **Rubber That Contains Fluorides**

Use great care when it is suspected that you may have to handle rubber that contains fluorides.

Certain seals which have to withstand high operating temperatures (e.g. in engines, transmissions, axles, hydraulic motors and pumps) may be made from rubber that contains fluorides, which, when exposed to high heat (fire), forms hydrogen fluoride and hydrofluoric acid. This acid is very corrosive and cannot be rinsed or washed off from the skin. It causes very severe burns which take a long time to heal.

It usually means that damaged tissue must be surgically removed. Several hours may pass after contact with the acid, before any symptoms appear and therefore one is not given any immediate warning. The acid may remain on the machine parts for several years after a fire.

If swelling, redness or a stinging feeling appears and one suspects that cause may be contact with heated rubber that contains fluorides, contact a medical doctor immediately. If a machine, or part of a machine, has been exposed to fire or severe heat, it must be handled by specially trained personnel. In all handling of machines after a fire, thick rubber gloves and protective goggles must be used.

The area around a part which has been very hot and which may be made of rubber that contains fluorides must be decontaminated by thorough and ample washing with limewater (a solution or suspension of calcium hydroxide, i.e. slaked lime in water). After the work has been completed, the gloves must be washed in limewater and then discarded.

## **Rubber and Plastics**

Polymer materials when heated, can form compounds that create a health hazard and can harm the environment. Scrapped rubber and plastic must never be burned. Extra precautions must be taken when servicing machines that have been in a fire or exposed to extreme heat.

If gas cutting or welding is to be done near such materials, the following safety instructions must be followed:

- Protect the material from heat.
- Use protective gloves, protective goggles and an approved respirator.

## **Waste Hazardous to the Environment**

Painted parts or parts made of plastic or rubber which are to be scrapped must never be burned, but must be taken care of by an approved refuse handling plant.

Batteries, plastic objects and anything else which is suspected of being dangerous to the environment must be taken care of in an environmentally safe way.

### **Check List After Fire**

When handling a machine which has been damaged by fire or been exposed to intense heat, the following protective measures must under all circumstances be followed:

Use thick, gloves made of rubber and wear goggles which are certain to protect your eyes.

Never touch burned components with your bare hands, as there is a risk that you may come into contact with melted polymer materials. First wash thoroughly with plenty of limewater (a solution or suspension of calcium hydroxide, i.e. slaked lime in water).

As a precaution, seals (O-rings and other oil seals) should always be handled as if they were made of rubber that contains fluorides.

Treat skin, which is suspected of having touched burned rubber that contains fluorides, with Hydrofluoric Acid Burn Jelly or something similar. Seek medical advice. Symptoms may not appear until several hours afterwards.

Discard gloves, rags etc. which are suspected of having touched burned rubber that contains fluorides.

### **Welding Repairs**

---

#### **NOTICE**

---

When disconnecting or connecting connectors between ECU and engine, or connector between ECU and the machine, always disconnect the battery to prevent damage to ECU.

If you do not follow this procedure, the ECU will be damaged and/or the engine will not operate properly.

---

When performing welding repairs, perform welding in a properly equipped place. Repairs must be performed by a qualified welder. Welding operations, can create potential hazards, including generation of gas, fire, or electric shock. Never let an unqualified welder do welding.

A qualified welder must do the following:

- To prevent battery explosion, turn battery disconnect switch to "OFF" position.
- Disconnect the connector between ECU and machine, and the connector between ECU and engine.
- Disconnect the negative (-) cable of battery.
- To prevent generation of gas, remove paint from location of the weld.



- If hydraulic equipment, piping or component ports close to them are heated, a flammable gas or mist could result in an explosion or fire. To prevent this, protect and insulate components from excessive heat.
- Do not weld on pipes or on tubes that contain flammable fluids. Do not flame cut pipes or tubes that contain flammable fluids. Before welding on pipes or tubes, or before flaming cut pipes or tubes, clean them thoroughly with a nonflammable solvent. Make sure pressure inside pipes or tubes does not cause a rupture of the component parts.
- If heat is applied directly to rubber hoses or piping under pressure, they may suddenly break, so cover and insulate them with a fireproof covering.
- Wear protective clothing.
- Make sure there is good ventilation.
- Remove all flammable objects and make sure a fire extinguisher is available.

### Preparation for Electrical Welding On Body Structure

To prevent damage to ECU by electrical welding, observe the following procedures:

1. Turn battery disconnect switch to "OFF" position.
2. Disconnect the connector between ECU and machine, and the connector between ECU and engine.
3. Disconnect the negative (-) cable of battery.
4. Proceed with welding.
5. After welding, connect the connector between ECU and machine, and the connector between ECU and engine.
6. Connect the negative (-) cable of battery.
7. Clean battery compartment.
8. Turn battery disconnect switch to "ON" position.
9. Close battery compartment door.

Figure 25

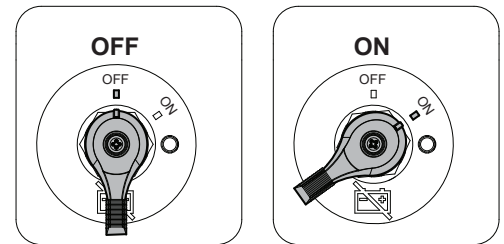

EX1500481

Figure 26

Electric Control Unit (ECU)

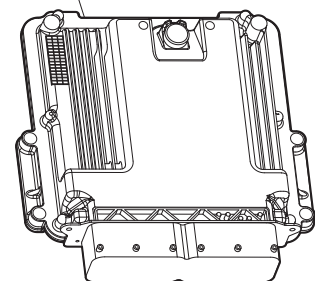

DS2001454

## Warning for Counterweight and Front Attachment Removal

---

### **WARNING**

---

#### AVOID DEATH OR SERIOUS INJURY

Removal of the machine counterweight, front attachment or any other part can affect the stability of the machine. This could cause unexpected movement, and result in death or serious injury.

Never remove counterweight or front attachment unless the upper structure is in-line with the lower structure.

Never rotate the upper structure once the counterweight or front attachment has been removed.

---

Figure 27

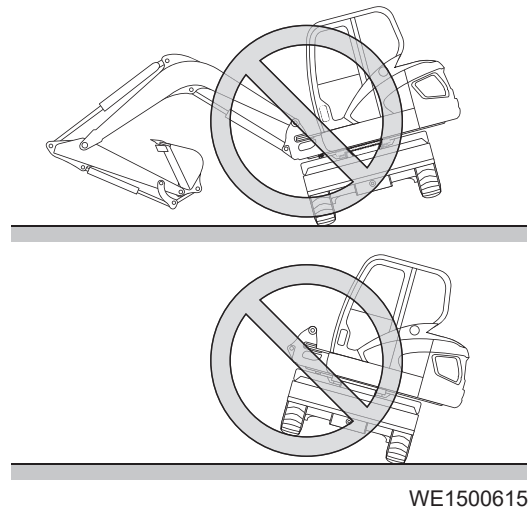

## Lock Inspection Covers

When performing maintenance with inspection cover open, use lock bar to secure cover and prevent accidental lowering of the cover caused by wind or movement of the machine.

## Working on Machine

When performing maintenance operations on machine, prevent tripping and falling by keeping area around your feet clean and free of objects and debris. Always do the following:

- Do not spill oil or grease.
- Do not leave tools laying around.
- Watch your step when walking.
- Never jump down from machine. When getting on or off machine, use steps and handrails, and maintain a three-point contact (both feet and one hand or both hands and one foot) to support yourself.
- If job requires it, wear protective clothing.
- To prevent injury from slipping or falling, when working on hood or covers, never stand or walk on areas except areas equipped with nonslip pads.
- If it is necessary to work under raised equipment or the machine, support work equipment and machine securely with blocks and stands strong enough to support weight of work equipment and machine.
- Do not work under the machine if lower structure is lifted off ground and the machine is supported only with work equipment. If any control levers are moved, or there is damage to hydraulic system, work equipment or the machine will suddenly drop causing death or serious injury.

Figure 28



## Accumulator

The pilot control system is equipped with an accumulator. For a short period of time after engine has been stopped, accumulator will store a pressure charge that allow hydraulic controls to be activated. Activation of any controls will allow selected functions to operate under force of gravity.

When performing maintenance on pilot control system, release hydraulic pressure in system as described in "Handling of Accumulator".

The accumulator is charged with high-pressure nitrogen gas. If it is improperly handled it can explode causing death or serious injury. Always observe the following precautions:

- Do not drill or punch holes in accumulator or expose it to any flames, fire or external heat source.
- Do not weld on accumulator.
- When performing disassembly or maintenance of accumulator, or when disposing of accumulator, charged nitrogen gas must be properly released. Contact your HYUNDAI distributor for assistance.
- Wear safety goggles and leather gloves when working on an accumulator. Hydraulic oil under pressure can penetrate skin and result in death or serious injury. If fluid enters skin or eyes, get immediate medical attention from a physician familiar with this injury.

## Compressed Air

- When cleaning filters, radiator or other components with compressed air, there is a hazard of flying particles that can result in serious injury.
- Always wear safety goggles, dust mask, leather gloves, and other protective devices.

## Supports and Blocking for Work Equipment

Do not allow weight or equipment loads to remain suspended and unsupported.

Lower work group to ground before leaving operator's seat.

Do not use hollow, cracked or unsteady wobbling supports.

Do not work under any equipment supported only by a lifting jack.

Figure 29

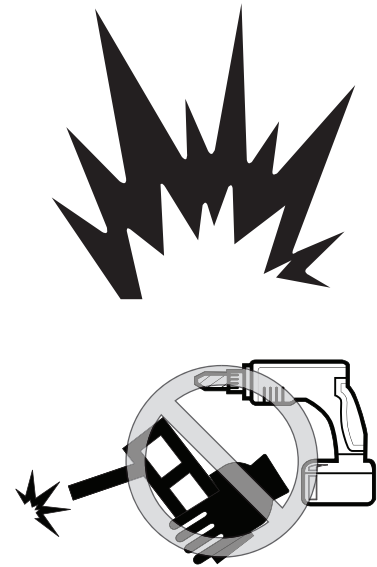

EX1400135

Figure 30



HDO1042L

## High-pressure Lines, Tubes and Hoses

When inspecting or replacing high-pressure piping or hoses, check to verify that pressure has been released from circuit. Failure to release pressure can result in death or serious injury. Release pressure as described in "Handling of Accumulator". Always do the following:

- Wear eye protection and leather gloves.
- Fluid leaks from hydraulic hoses or pressurized components can be difficult to see but has enough force to pierce skin and can result in death or serious injury. Always use a piece of wood or cardboard to check for suspected hydraulic leaks. Never use your hands or expose your fingers. Wear safety goggles.
- Do not bend high-pressure lines. Do not strike high-pressure lines. Do not install lines, tubes or hoses that are bent or damaged.
- Make sure that all clamps, guards and heat shields are correctly installed to prevent vibration, rubbing against other parts, and excessive heat during operation.
- Replace hose or components if any of the following problems are found:
  - Damage or leakage from hose end fitting.
  - Wear, damage, cutting of hose covering, or wire braiding is exposed on any hose.
  - Cover portion is swollen in any section.
  - The hose is twisted or crushed.
  - Foreign material is embedded in hose covering.
  - Hose end is deformed.
  - Connection fittings are damaged or leaking.

**NOTE:** Refer to "Hose In-service Lifetime Limit (European Standard ISO 8331 and EN982 (CEN))" for more information.

High-pressure is generated inside engine fuel lines when engine is running. Before performing inspection or maintenance of fuel line system, wait for at least thirty seconds after stopping engine to let internal pressure drop and tip breather cap up to release residual pressure.

Oil or fuel leaks from high-pressure hoses can cause fire or improper operation, which can result in death or serious injury. If any loose bolts are found, stop work and tighten to specified torque. If any damaged hoses are found, stop operations immediately and contact your HYUNDAI distributor for replacement parts.

Figure 31

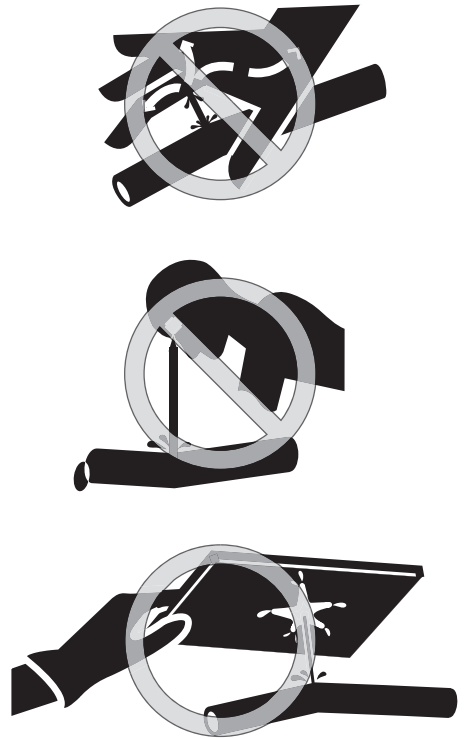

EX1400129

## Battery

### Battery Hazard Prevention

Battery electrolyte contains diluted sulfuric acid and generates hydrogen gas. Hydrogen gas is highly explosive, and improper handling can cause death or serious injury, or fire. Do not allow electrolyte to contact skin or eyes. Always wear safety goggles and protective clothing when servicing batteries. Wash hands after touching batteries and connectors. Use of acid-resistant gloves is recommended. Always observe the following precautions.

- Do not smoke or bring any flame near battery.
- When working with batteries, Always wear safety goggles, protective clothing, and acid-resistant gloves.
- If you spill battery electrolyte on yourself or your clothes, immediately flush area with water.
- If battery electrolyte gets into your eyes, flush them immediately with large quantities of water and get immediate medical attention from a physician familiar with this injury.
- If you accidentally drink battery electrolyte, call a poison prevention center immediately and get immediate medical attention from a physician familiar with this injury.
- When cleaning top surface of battery, wipe it with a clean, damp cloth. Never use gasoline, thinner, or any other organic solvent or detergent.
- Tighten battery caps.
- If battery electrolyte is frozen, do not charge battery or start engine with power from another source. This could cause the battery to explode and start a fire.
- When charging battery or starting with power from another source, let battery electrolyte thaw and check that there is no leakage of battery electrolyte before starting operation.
- Always remove battery from machine before charging.
- Do not use or charge battery if battery electrolyte level is below LOW LEVEL line. This can cause an explosion. Periodically check battery electrolyte level and add distilled water to bring electrolyte level to FULL LEVEL line.
- Before maintaining or working with batteries, turn starter switch to "O" (OFF) position.

Since there is a potential hazard that sparks could be generated, always do the following:

- Do not let tools, rings or other metal objects make any contact between battery terminals. Do not leave tools or other metal objects lying near battery.

Figure 32



EX1400136

- When disconnecting battery terminals, wait for approximately one minute after turning engine starter switch key to "O" (OFF) position, and be sure to disconnect grounding terminal; negative (-) terminal first. Conversely, when connecting them, begin with positive (+) terminal and then grounding (-) terminal, Make sure that all terminals are connected securely.
- Flammable hydrogen gas is generated when battery is charged. Remove battery from machine, take it to a well ventilated place, and remove battery caps, before charging it.
- After charging, tighten battery caps securely.
- After charging, secure battery back in machine.

When repairing or welding electrical system, wait for approximately one minute after turning engine starter switch key "OFF". Then disconnect negative (-) terminal of battery to stop flow of electricity.

# Environment and Circumstances

## Work Site Areas Requiring Extra Caution

- Do not operate too close to edge of a quay, ramp, etc.
- Do not operate too close to edge of a steep slope or drop-off. Take care when working in a place where machine may tip over.
- Do not operate on soft ground or near riverbanks that could collapse or where ground may not support weight of excavator.
- Observe changes in ground and traction conditions after a rain or other changes in weather.

## Digging Under an Overhang

Do not dig work face under an overhang. This can cause overhang to collapse and fall on top of the machine.

- Do not perform overhead demolition work. This can cause broken objects and debris to fall on top of machine causing death or serious injury, or property damage.

Figure 33

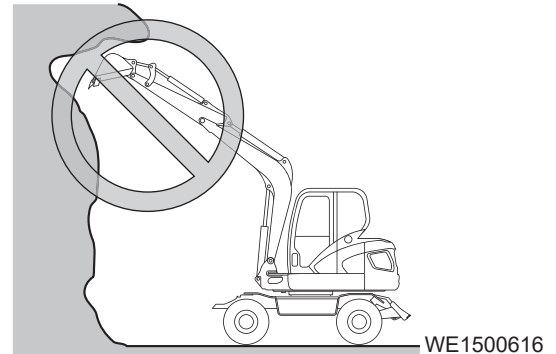

## Deep Digging

Do not perform deep digging under front of machine. The ground under machine may collapse and cause machine to fall resulting in death or serious injury.

Working heavy loads on loose, soft or uneven ground, can cause side load conditions resulting in a tip over and injury. Traveling without a load or a balanced load may also be hazardous.

Never rely on lift jacks or other inadequate supports when work is being done. Block tires fore and aft to prevent any movement.

Use machine only for its intended purpose. Using it for other purposes will cause failures.

- Do not perform demolition work under machine. There is a hazard that the machine may become unstable and tip over.
- When working on or from top of buildings or other structures, check if structure can support weight of machine and attachment. If a building structure collapses, this can cause death or serious injury.

Figure 34

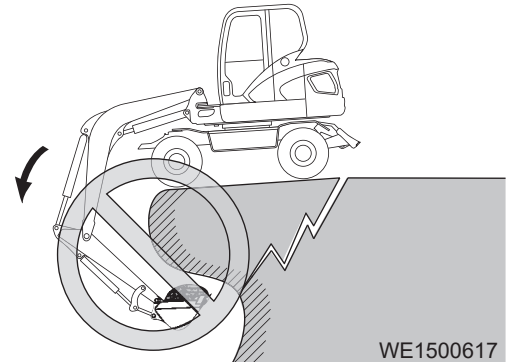

## Drop-off or Edge

When working at edge of an excavation or near a drop-off, the machine could tip over, which can result in death or serious injury. Always fasten your seat belt. Check ground conditions of work site before operating to prevent the machine from falling or

roll-over, and to prevent ground, stockpiles, or banks from collapsing.

Do not travel too close to edge of a drop-off.

### **Poor Visibility**

For good visibility, always do the following:

- When working in dark areas, attach working lights and front lights to the machine. If necessary, set up additional lighting at work site.
- Stop operations when visibility is poor, such as in fog, mist, snow, and rain. Wait for visibility to improve before starting operation.

To avoid hitting work equipment and damaging other property, always do the following:

- When working in tunnels, on bridges, under electrical wires, or when parking the machine or performing other operations in places with limited height, be careful not to hit and damage other equipment or property.
- To prevent hitting objects, operate machine at a slow speed when working in confined spaces, indoors, or in crowded areas.
- Do not swing bucket over the top of personnel or over operator's cabin of dump truck.

### **Loose or Soft Ground**

Do not operate on soft ground or near edge of drop-offs, overhangs, and deep ditches. The ground can collapse because of the weight of the machine causing the machine to fall or roll-over.

Check ground conditions before beginning work with the machine. If ground is soft, reposition the machine before operating.

The excavated material must not be dumped too close to edge. How far away from edge of trench excavated material must be dumped depends on soil type and moisture content. If loose clay is being excavated, place it at least 5 m (16 ft) away from edge.

If excavated material is dumped too close to edge, its weight can cause a landslide.

Thawing of frozen ground, rain, traffic, piling and blasting are other factors which increase risk of landslide. The risk also increases on sloping ground. If it is not possible to dig a trench and adequately slope its sides, always install shoring equipment.

Loose ground may easily give way under weight of the machine.

When working on loose or unstable ground, it is important not to dig too deep and to carefully reposition the machine. Do not panic and do not raise bucket, if ground should begin to collapse. Lower work equipment to improve stability of machine.

Never dig under machine, if there is a potential of causing a landslide.



## High-voltage Cables

Do not travel or operate machine near electrical cables or overhead power lines. There is a hazard of electric shock, which can cause property damage and result in death or serious injury. The bucket or other attachment does not have to make physical contact with power lines for current to cause an electrocution.

Use a spotter and hand signals to stay away from power lines not clearly visible to operator. On work sites where machine may operate close to electrical cables, always do the following:

- Remember that electrical voltage determines what the minimum distance is to stay away from the power line. See the following table for minimum distances when working near electrical power lines. Electrical flash over can occur and damage machine and cause death or serious injury.

Voltage	Minimum Distance
6.6 kV	3 m (9' 10")
33.0 kV	4 m (13' 1")
66.0 kV	5 m (16' 5")
154.0 kV	8 m (26' 3")
275.0 kV	10 m (32' 10")

- Always contact the power company responsible before beginning work near high voltage power lines.

## Underground Operation

If excavation is in an underground location or in a building, make sure there is adequate overhead clearance, and adequate ventilation.

Special equipment and engines may be required in some countries. Contact your HYUNDAI distributor for more information.

Check that there is sufficient room for machine and load.

Move slowly.

Make sure that authorities or companies responsible for underground cables, utilities, and electrical lines have been contacted and that their instructions are followed. Also check which rules apply to ground personnel regarding exposing cables, utilities and electrical lines.

Consider all electrical cables as live.

Figure 35

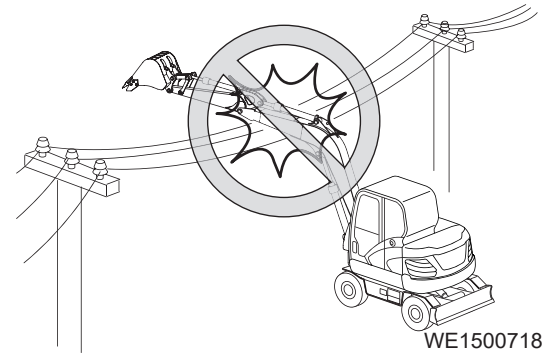
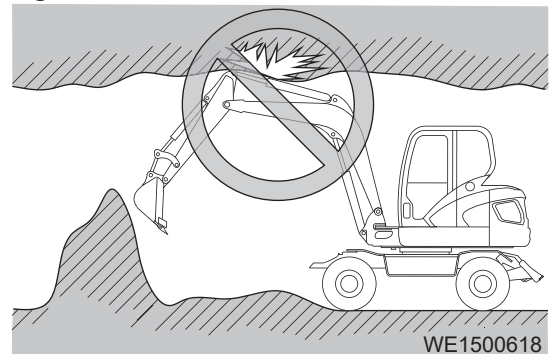

Figure 36



## Working in Water

---

### NOTICE

---

Do not exceed maximum permissible water depth. The water level must not reach higher than centerline of the axle housing.

---

After working in water, lubricate all lubrication points on undercarriage, which have been underwater so water is removed. Check that no water has entered travel gearboxes and undercarriage components.

## Working in Contaminated Environment

When working within area which is contaminated or where there is a health risk, check local regulations and contact your HYUNDAI distributor for assistance with identifying what additional safety precautions need to be taken.

## Operation in Extreme Conditions

### Operation In Extreme Cold

In extremely cold weather, avoid sudden travel movements and stay away from even slight slopes. The machine could slide down the slope.

Snow accumulation could hide potential hazards and slippery surfaces.

Warming up engine for a short period may be necessary to avoid operating with sluggish or reduced working capacity. The jolting shocks and impact loads caused by bumping or bottoming boom or attachment could cause severe stress in very cold temperatures. Reducing work cycle rate and workload may be necessary.

If machine is to be operated in extremely cold weather temperatures, certain precautions must be taken. The following paragraphs detail checks to be made to be certain machine is capable of operating at these temperatures.

1. Preheat the engine before start-up.
  - Preheat the engine before start-up. Wait 3 to 4 seconds after preheating until voltage of the battery return, and then actuate the starter switch.
2. Keep batteries fully charged to prevent freezing. If distilled water is added to batteries, run engine at least one hour to mix electrolyte solution. When temperature drops below  $-10^{\circ}\text{C}$ , efficacy of the battery is reduced accordingly. Insulation of the battery prevents reduction of efficacy, and supports improvement of starting power of the starter.

Figure 37

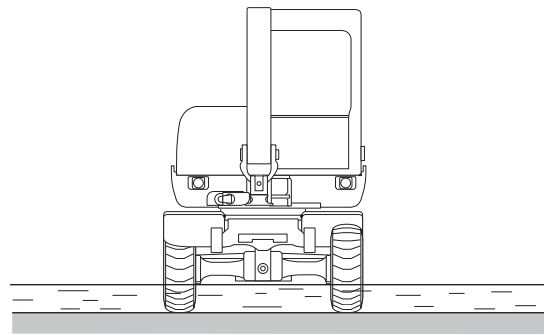

DS2000769

---

## **WARNING**

---

### **AVOID DEATH OR SERIOUS INJURY**

Explosion of the battery can cause death or serious injury.  
Never attempt to directly heat the battery with open fire.

---

3. Keep engine in good mechanical condition for easy starting and good performance during adverse weather.
4. Use engine oil with proper specifications for expected temperatures. Refer to “Table of Recommended Lubricants” for more information.
5. Always keep the fuel tank fully filled after completion of the operation. Always drain water from the fuel tank before and after the operation. In addition, check the water separator, and drain it if required. The fuel filter, if frozen, may interrupt the flow of fuel. Periodically remove water from the fuel tank, drain water from the filter, and replace the filter upon regular basis. To prevent fuel from being clogged because of formation of wax in fuel, make sure that wax formation point of fuel is lower than atmospheric temperature.

---

## **WARNING**

---

### **AVOID DEATH OR SERIOUS INJURY**

Explosion of the fuel tank can cause death or serious injury. Never attempt to directly heat the fuel tank with open fire.

---

6. Lubricate entire machine according in refer to “Lubrication and Service Chart” for more information.
7. Start engine and allow it to reach normal operating temperature before operating.
  - If mud and ice collects and freezes on any of moving parts while machine is idle, apply heat to thaw frozen material before attempting to operate machine.
  - Operate hydraulic units with care until they have reached a temperature which enable them to operate normally.
  - Check all machine controls and functions to be sure they are operating correctly.
8. An extra outer air filter must be kept in operator's cabin to replace element that could become iced and cause restricted airflow to engine.
9. Clean off all mud, snow and ice to prevent freezing. Cover machine with a tarp if possible, keep ends of tarp from freezing to ground.

## Operation in Extreme Heat

Continuous operation of machine in high temperatures can cause machine to overheat. Monitor engine and hydraulic system temperatures and stop machine to let it cool, when necessary.

1. Make frequent inspections and services of fan and radiator. Check coolant level in radiator. Check grilles and radiator fins for accumulation of dirt, debris and insects which could block cooling passages.
  - Formation of scale and rust in cooling system occurs more rapidly in extremely high temperatures. Change antifreeze each year to keep corrosion inhibitor at full strength.
  - If necessary, flush cooling system periodically to keep passages clear. Avoid use of water with a high alkali content which increases scale and rust formation.
2. Check level of battery electrolyte daily. Keep electrolyte above plates to prevent damage to batteries. Use a slightly weaker electrolyte solution in hot climates. Batteries self-discharge at a higher rate if left standing for long periods at high temperatures. If machine is to stand for several days, remove batteries and store in a cool place.

---

### NOTICE

---

Do not store acid type storage batteries near stacks of tires. Acid fumes can damage rubber.

---

3. Service fuel system as directed in refer to “Fuel Level - Check” for more information. Check for water content before filling fuel tank. High temperatures and cooling off cause condensation in storage drums.
4. Lubricate as specified in refer to “Lubrication and Service Chart” for more information.
5. Do not park machine in sun for long periods of time. If possible, park machine under cover to protect it from sun, dirt and dust.
  - A. Cover machine if no suitable shelter is available. Protect engine compartment and hydraulics from dirt and debris.
  - B. In hot, damp climates, corrosion will occur on all parts of machine and will be accelerated during rainy season. Rust and paint blisters will appear on metal surfaces and fungus growth on other surfaces.
  - C. Protect all unfinished, exposed surfaces with a film of preservative lubricating oil. Protect cables and terminals with ignition insulation compound. Apply paint or suitable rust preventive to damaged surfaces to protect them from rust and corrosion.

## Operation In Dusty and Sandy Areas

Operation of machine can cause dust in almost any area. However, when in predominantly dusty or sandy areas, additional precautions must be taken.

1. Keep cooling system fins and cooling areas clean. Blow out with compressed air, if possible, as often as necessary.

---

### **WARNING**

---

#### **AVOID DEATH OR SERIOUS INJURY**

Wear goggles when using compressed air to prevent face or eye injury.

---

2. Use care when servicing fuel system to prevent dust and sand from entering tank.
3. Service air cleaner at frequent intervals, check air restriction indicator daily and keep dust cup and dust valve clean. Prevent dust and sand from entering engine parts and compartments as much as possible.
4. Lubricate and perform services outlined on current lubrication chart on machine and "Lubrication and Service Chart". Clean all lubrication fittings before applying lubricant. Sand mixed with lubricant becomes very abrasive and accelerates wear on parts.
5. Protect machine from dust and sand as much as possible. Park machine under cover to keep dust and sand from damaging unit.

## Operation in Rainy or Humid Conditions

Operation under rainy or humid conditions is similar to that as in extreme heat procedures previously listed.

1. Keep all exposed surfaces coated with preservative lubricating oil. Pay particular attention to damaged or unpainted surfaces. Cover all paint cracks and chip marks as soon as possible to prevent corrosive effects.

## Operation in Saltwater Areas

Saltwater and saltwater spray is very corrosive. When operating in saltwater areas, or in or around snow, observe the following precautions:

1. When exposed to saltwater, dry machine thoroughly and rinse with freshwater, as soon as possible.
2. Keep all exposed surfaces coated with preservative lubricating oil. Pay attention to damaged paint surfaces.
3. Keep all painted surfaces in good repair.
4. Lubricate machine as prescribed on lubrication chart on machine or "Lubrication and Service Chart. Shorten lubricating intervals for parts exposed to salt water.
5. Check operating controls to ensure proper functionality and that they return to "NEUTRAL" when released.

## Operation at High Altitudes

Operation instructions at high altitudes are the same as those provided for extreme cold. Before operating at high altitudes, engine fuel and air mixture may have to be adjusted according to appropriate engine manual.

1. Check engine operating temperature for evidence of overheating. The radiator cap must make a perfect seal to maintain coolant pressure in cooling system.
  - Perform warming-up operation thoroughly. If machine is not thoroughly warmed up before control levers or control pedals are operated, reaction of machine will be slow.
  - If battery electrolyte is frozen, do not charge battery or start engine with a different power source. There is a potential hazard that could cause a battery explosion or fire.
  - Before charging or starting engine with a different power source, thaw battery electrolyte and check for any leakage of electrolyte before starting.

## Operation During Electrical Storms

During electrical storms, do not enter or exit machine.

- If you are off machine, keep away from machine until storm passes.
- If you are in cabin, remain seated with machine stationary until storm passes. Do not touch controls or anything metal.

## Exhaust Ventilation

Engine exhaust gases can cause unconsciousness, loss of alertness, judgment and motor control. This can result in death or serious injury.

Make sure there is adequate ventilation before starting engine in any enclosed area.

Check for and be aware of any open windows, doors or ductwork where exhaust may be carried, or blown by wind, exposing others to hazardous exhaust gases.

### Ventilation for Enclosed Area

If it is necessary to start engine within an enclosed area, or when handling fuel, flushing oil, or paint; open doors and windows to ensure that adequate ventilation is provided to prevent gas poisoning.

Diesel engine exhaust contains products of combustion which can be harmful to your health.

Always run engine in a well ventilated area. If you are in an enclosed area, vent exhaust to outside.

Figure 38



ARO1770L

## Asbestos Information

---

### **WARNING**

---

#### AVOID DEATH OR SERIOUS INJURY

Avoid exposure to dust containing asbestos as it can cause death or serious injury to the lungs and other organs (mesothelioma, lung and other cancers, and asbestoses).

---

Asbestos dust can be HAZARDOUS to your health if it is inhaled. Materials containing asbestos fiber can be present on work sites. Breathing air that contains asbestos fiber can ultimately cause serious or fatal lung damage or diseases such as mesothelioma, lung and other cancers, and asbestoses. To prevent lung damage from asbestos fiber, observe the following precautions:

- Use an approved respirator that is approved for use in an asbestos-laden atmosphere.
- Use water for cleaning to keep down dust.
- Always observe any regulations related to work site and working environment.
- Avoid brushing or grinding materials that contain asbestos.
- A vacuum cleaner that is equipped with a high efficiency particulate air filter can also be used.
- Comply with applicable laws and regulations for workplace.
- Stay away from areas that might have asbestos particles in air.

## Silica Dust Information

---

### **WARNING**

---

#### AVOID DEATH OR SERIOUS INJURY

Avoid exposure to dust containing crystalline silica particles as it can cause serious injury to the lungs (silicosis).

---

Cutting or drilling concrete containing sand or rock containing quartz can result in exposure to silica dust. Do not exceed Permissible Exposure Limits (PEL) to silica dust as determined by OSHA or other work site rules, laws and regulations. Use a respirator, water spray or other means to control dust. Silica dust can cause lung disease and is known to the state of California to cause cancer.

## Disposal of Hazardous Materials

Physical contact with used motor oil or gear oil could create a health risk. Wipe oil from your hands promptly and wash off any remaining residue.

Used motor oil or gear oil is an environmental contaminant and should only be disposed of at approved collection facilities. To prevent pollution of environment, always do the following:

- Never dump waste oil in a sewer system, rivers, etc.
- Always put drained oil from your machine in approved, leak proof containers. Never drain oil directly onto ground.
- Obey appropriate laws and regulations when disposing of harmful materials such as oil, fuel, solvent, filters, and batteries.

Improperly disposing of waste can threaten environment. Potentially harmful fluids must be disposed of according to local regulations.

Use all cleaning solutions with care. Report all necessary repairs.

## Sound

Sound Level Information: Hearing protection may be needed when machine is operated with an open operator station for extended periods or in a noisy environment.

Sound pressure level (LpA) at operator position (Measurement according to ISO 6396)	74 dB(A)
Sound power level (LwA) around the machine (Measurement according to 2000/14/EC with applicable appendices and measuring method according to ISO 6395)	98 dB(A)

## Vibration Information

**NOTE:** *The level of vibration is influenced by many different parameters such as operator training, job site organization, weather, material, environment, machine type, machine and seat suspension system, attachments, and condition of the machine.*

Measurements are obtained on a representative machine, using measuring procedures as described in the following standards: ISO 2631/1, ISO 5349, and SAE J1166.

Vibration levels were given consideration in accordance with uncertainty (K) determined to manufacturer.

### Hand/Arm Vibration Level

The vibration total value to which the hand-arm system is subjected, is less than  $2.5 \text{ m/s}^2$ .

### Whole Body Vibration Level

The highest root mean square value of weighted acceleration to which the whole body is subjected, less than  $0.5 \text{ m/s}^2$ .

Figure 39

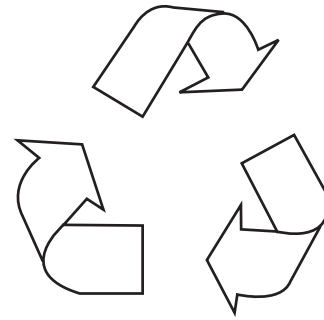

FG009156



## **Guidelines for Use and Working Conditions of Earth-moving Machinery to Reduce Vibration Levels (ISO/TR 25398 Annex E)**

Properly adjusting and maintaining machines, operating machines smoothly, and maintaining the terrain conditions can reduce whole-body vibrations. The following can help the users of earth-moving machinery reduce whole-body vibration levels.

1. Use the right type and size of machine, equipment, and attachments.
2. Maintain machines according to the manufacturer's recommendations: (for wheeled machine)
  - Tire pressure;
  - Brake and steering systems;
  - Controls, hydraulic system and linkages.
3. Keep the terrain where the machine is working and traveling in good condition:
  - Remove any large rocks or obstacles;
  - Fill any ditches and holes;
  - Provide machines and schedule time to maintain terrain conditions.
4. Use a seat in conformance with ISO 7096 and keep the seat maintained and adjusted:
  - Adjust the seat and suspension for the weight and size of the operator;
  - Inspect and maintain the seat suspension and adjustment mechanisms.
5. Steer, brake, accelerate, shift gears, and move the attachments smoothly. (for wheeled machine)
6. Adjust the machine speed and travel path to minimize the vibration level:
  - Drive around obstacles and rough terrain conditions;
  - Slow down when it is necessary to go over rough terrain.
7. Minimize vibrations for long work cycle or long distance traveling: (for wheeled machine)
  - Use machines equipped with suspension systems;
  - Use lift arm suspensions on wheel excavator;
  - If no suspension system is available, reduce speed to prevent bouncing;
  - Haul machines long distances between work sites.
8. Back pain associated with whole-body vibrations can be caused by other risk factors. To minimize the risk of back pain:
  - Adjust the seat and controls to achieve good posture;

- Adjust the mirrors to minimize twisted posture;
- Provide breaks to reduce long periods of sitting;
- Avoid jumping down from the cab or access system;
- Minimize repeated handling and lifting of loads;
- Minimize any shocks and jolts during sports and leisure activities.

# Operation

Always make sure that the machine is properly maintained.

## Before Engine Starting

### Machine Condition

Every day before starting engine for first time, perform the following checks and repair machine before operating, as necessary. If these checks are not properly done death or serious injury could result.

- Check coolant, fuel, and hydraulic tank oil levels, and check for clogged air cleaner and damage to electrical wiring.
- Check operation of gauges, cameras (if equipped) and angle of mirrors, and check that safety lever is in LOCKED position.
- Check that work equipment and travel controls move freely, and work controls return to "NEUTRAL" when released.
- Check that attachment is properly attached and locked.

Make sure that the machine is equipped with a lighting system that is adequate for job conditions and lights are working properly.

Before moving machine, check position of undercarriage. The normal travel position is with idler wheels to front under cabin and drive sprockets to rear. When undercarriage is rotated in reversed position, directional or travel controls must be operated in opposite directions.

Before performing checks, move machine to an area where there are no obstructions, and operate slowly. Do not allow personnel near machine.

Know maximum operating dimensions of your machine.

### Work Site

Before starting operations, thoroughly check work area for any hazards, such as underground utility lines, overhead electrical lines, unstable ground, excessive slopes, etc.

Before starting engine and moving machine, make sure that no one is underneath machine, around machine, or on machine.

Know width and length of your machine and work equipment to maintain proper clearance when you operate machine or work equipment near fences or near boundary obstacles.

Know appropriate work site hand signals and personnel that are authorized to give hand signals. Follow hand signals from only one person.

If you need to operate on a street, protect pedestrians and cars by designating a person for work site traffic duty or by erecting fences and posting "No Entry" signs around work site.

Erect barricades or fences, post "No Entry" signs, and take other steps to prevent people from coming close to or entering work site. If people come too close to a moving machine, they may be

Figure 40

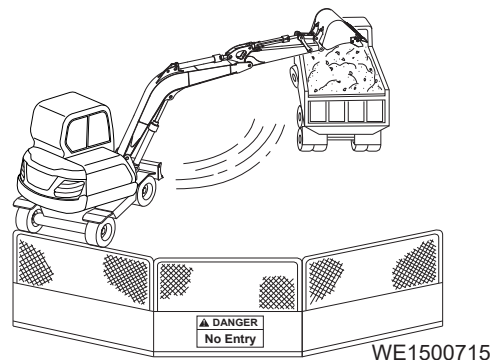

struck or caught by machine, and this can result in death or serious injury.

## Mounting/Dismounting

Before getting on or off machine, if there is any oil, grease, or mud on handrails, steps, wipe it off immediately. Always keep these parts clean. Repair any damage and tighten any loose bolts.

Never jump on or off machine. In particular, never get on or off a moving machine. These actions can result in death or serious injury.

When getting on or off machine, always face machine. Maintain three-point contact (both feet and one hand or one foot and both hands) with handrails and steps to ensure that you support yourself securely.

Never hold onto any control levers when getting on or off machine.

Securely latch door. If you grip handrail inside door when moving on top and door latch is not securely engaged, door may move and cause you to fall.

Use points marked by arrows in diagram when getting on or off machine.

Do not carry tools or supplies when you mount or dismount the machine.

## Cleaning

Remove all straw, wood chips, leaves, grass, paper and other flammable debris accumulated in engine compartment, mufflers and around battery. Remove any dirt from window glass, mirrors, handrails, and steps.

Do not leave tools or spare parts in operator's cabin. vibration of machine during operation can cause tools or spare parts to fall and damage or break control levers or switches. Tools and spare parts can also get caught in spaces between control levers and cause accidental movement of work equipment causing death or serious injury.

When entering operator's cabin, always remove all mud and oil from your shoes. If you operate travel pedal with mud or oil stuck to your shoes, your foot could slip off the control, or dirt and debris may interfere with proper operation of control levers.

After using ashtray, make sure that any matches or cigarettes are properly extinguished, and be sure to close ashtray.

Clean window glass and working lights for good visibility.

Do not stick suction pads to window glass. Suction pads act as a lens and can cause fire.

Never bring flammable or explosive items into operator's cabin. Do not leave cigarette lighters laying around operator's cabin. If temperature inside operator's cabin becomes too high, there is a potential hazard that lighter could explode.

Figure 41



Secure all loose items such as lunch boxes, and other items that are not a part of equipment.

## Operator Station

Inspect condition of seat belt and mounting hardware. Replace any parts that are worn or damaged. Do not use a seat belt extension on a retractable seat belt.

Adjust seat so full pedal travel can be achieved with operator's back against back of seat.

Keep all windows and doors closed on machine.

Adjust operator's seat to a position where it is easy to perform operations, and check that there is no damage or excessive wear to seat belt or mounting clamps.

Adjust and clean mirrors so area to rear of machine can be seen clearly from operator's seat.

When standing up from operator's seat, always place safety lock lever securely in "LOCK" position. If you accidentally move work equipment levers when they are not locked, the machine could suddenly move and cause damage, death or serious injury.

## Seat Belt

Check seat belt daily for correct function.

Inspect seat belt system more often if machine is exposed to severe environmental conditions or applications. Conduct the following inspections and replace seat belt system as necessary:

1. Check webbing. If system is equipped with a retractor, pull webbing completely out and inspect full length of webbing. Look for cuts, wear, fraying, dirt and stiffness.
2. Check buckle and latch for correct operation.
3. Make sure latch plate is not excessively worn, deformed or buckle is not damaged or casing is broken.
4. Check retractor web storage device (if equipped) by extending webbing and checking that it spools out and retracts correctly.
5. Check webbing in areas exposed to ultraviolet (UV) rays from sun or extreme dust or dirt. If original color of webbing in these areas is extremely faded and/or webbing is packed with dirt, webbing strength may be reduced.

**NOTE:** *Contact your HYUNDAI distributor for seat belt system replacement parts.*

---

## WARNING

---

### AVOID DEATH OR SERIOUS INJURY

Failure to properly inspect and maintain seat belt and seat belt system can cause lack of operator restraint and can result in death or serious injury.

Before fastening seat belt, check that there is no problem in belt mounting bracket. If it is worn or damaged, replace seat belt. Fasten seat belt so it is not twisted.

Always wear seat belt when operating machine.

---

## Visibility Information

A rear view camera (if equipped) and mirrors provide the operator with additional means to see the work area.

**NOTE:** *These devices may vary from one region to another, depending upon local and regional regulations. If a machine is moved or sold into another region or marketplace, it is the owner's responsibility to make sure it complies with all applicable regulations.*

**NOTE:** *Your machine may be equipped with additional visual aids other than the Figure 42 shown.*

Figure 42

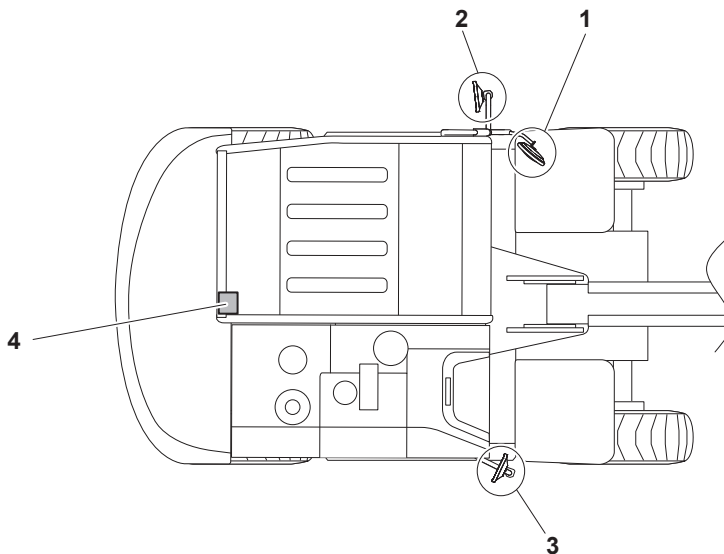

1. Front Mirror on the Cabin (1)
2. Front Mirror on the Cabin (2)
3. Front Mirror on the Right Frame (3)
4. Rear View Camera

DS1801541

---

## WARNING

---

### AVOID DEATH OR SERIOUS INJURY

Failure to check for and clear people from the surrounding area of a machine can result in death or serious injury. The operator should make sure that visual aids (mirrors and camera(s)) are in proper working condition.

---

Your machine may be equipped with visual aids such as mirrors or a rear view camera. Even with these aids, there still may be areas around the machine which cannot be seen from the operator's seat. Always keep personnel and bystanders out of the work area. Be careful when operating and always look in direction of travel.

Adjust visual aids for best visibility around machine.

When swinging work equipment or backing up, press camera button (if equipped) to change display mode on display monitor so you can check rear and side of machine.

The Around View Monitoring (AVM) system (if equipped) provides view of surroundings and an operator can find who stands near.

---

## NOTICE

---

Do not rely solely on AVM. every time swivel and moving, be sure No bystanders nearby and take a slow.

---

Before moving machine, look around work site and use mirrors and display monitor to confirm that no one is in the work area.

While operating or traveling in places with poor visibility it may be impossible to confirm condition of work site. Inspect and remove any obstacles around the machine that could be damaged and keep other personnel out of the work area.

Inspect equipment and repair immediately if there are problems with visual aids. If machine cannot be fixed immediately, DO NOT use the machine. Contact your HYUNDAI distributor and arrange for repairs.

### **Restricted Visibility**

Some areas may not be seen from the operator's position.

Get aid from proper job site organization and minimize visibility masking hazard.

Refer to Operation and Maintenance Manual for more information regarding job site organization.

Figure 43 ~ Figure 44 provide an approximate visual indication of the areas at ground level inside a radius of 12 m (39' 4") from the operator of significant restricted visibility for various machine configurations.

Figure 45 provides the position of the attachment and equipment in the Travel position.

- Visible areas without visual aids at the ground level

**Figure 43**

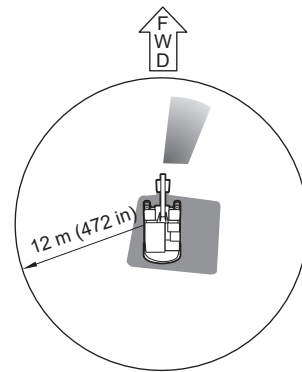

DS1801542

- Visible areas with rear CCTV and mirrors

**Figure 44**

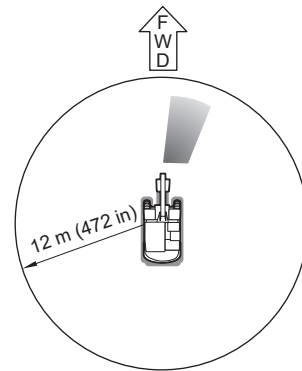

DS1801543

- Machine travel position
  - A is 3.3 m (10' 10") from swing center to bucket pin
  - B is 3.3 m (10' 10") from ground to arm pin

**Figure 45**

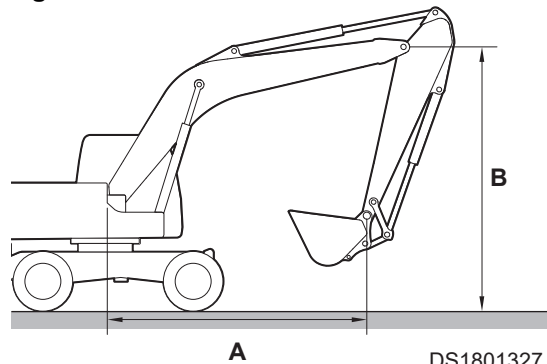

DS1801327

### Mirror Adjustment

Frequently ensure the mirrors are directed properly.

- Park the machine on a level surface.
- Lower the attachment to the ground.
- Lower the safety lever to the LOCK position.
- Stop the engine.
- Use the machine access system.

**NOTE:** *You may need hand tools to adjust certain types of mirrors.*



1. Front mirror on the cabin (1)

If equipped, adjust the front mirror on the cabin (1) so the front of right tire can be seen from the operator seat.

**Figure 46**

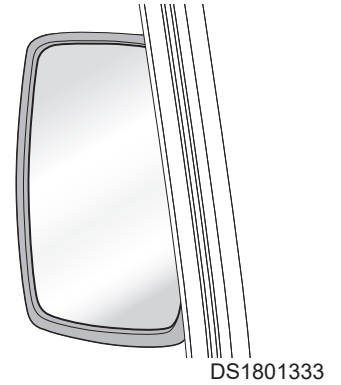

2. Front mirror on the cabin (2)

If equipped, adjust the front mirror on the cabin (2) so the left side of machine can be seen from the operator seat.

**Figure 47**

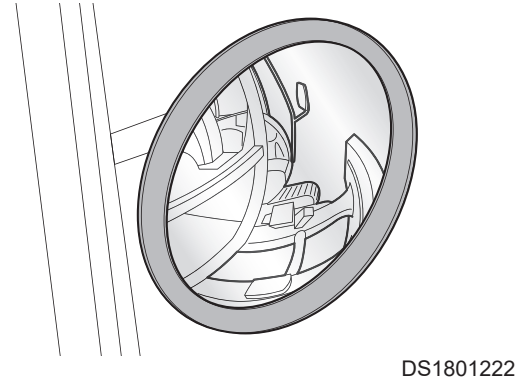

3. Front mirror on the right frame (3)

If equipped, adjust the front mirror on the right frame (3) so the right side can be seen from the operator seat.

**Figure 48**

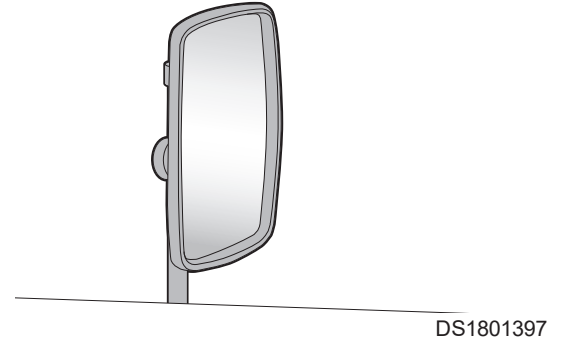

4. Additional mirrors other than Figure 42

If equipped, adjust the mirrors whenever you change operators and ensure the mirrors are in proper working conditions.

**Work Site Rules**

- If visibility cannot be sufficiently assured, use a flagman. The operator should pay careful attention to signals and follow instructions from flagman.
- Signals should only be given by one flagman.
- When working in dark places, turn "ON" work lights and front lights on the machine. Set up additional lighting in area.
- Stop operations if there is poor visibility, such as fog, snow, rain, or sandstorms.
- Check mirrors and rear view camera (if equipped) on machine before starting operations. Clean off any dirt and adjust view for good visibility.

When operating or traveling during poor visibility conditions, follow the preceding work site rules.

It may not be possible to adjust all visual aids to see all the way around the machine. Therefore, additional precautions such as

flagman, barricades, etc., must be taken to keep other personnel out of the work area.

## Boost Starting or Charging Battery

Follow these instructions to prevent an explosion or fire when connecting booster cables to batteries:

- Turn "OFF" all electric equipment before connecting leads to battery. This includes electric switches on battery charger or battery booster equipment.
- When boost starting from another machine or vehicle do not allow two machines to touch. Wear safety goggles and gloves while battery connections are made.
- Refer to "Starting Engine With a Booster Cable" for more information.
- Connect positive (+) cable first when installing cables and disconnect negative (-) cable first when removing them. The final cable connection, at the metal frame of the machine being charged or boost started, must be as far away from the battery as possible.

## Starting Engine

Only operate the machine from the operator's seat with your seat belt fastened.

Only operate controls while engine is running.

Check for proper operation of all controls and all protective devices while you operate the machine slowly in an open area.

- Read and understand control pattern (If Equipped) before operating. Check that movement of the machine matches display on control pattern label. If it does not match, replace it immediately with correct control pattern label.
- Check operation of work equipment, travel system and swing system.
- Check for any problem with machine. Check for unusual sounds, vibration, heat, odor, or improper readings from gauges. Check for any oil or fuel leaks.
- If any problem is found, stop operation and perform repairs immediately.

Do not use cellular telephones inside operator's cabin when driving or operating the machine.

When operating the machine, do not extend your hands or head out of window.

The boom and arm linkage can allow work tool or attachment to contact undercarriage or cabin. Be aware of position of work tool.

Figure 49

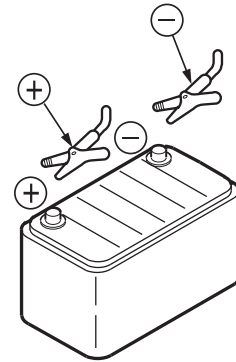

HAOA310L

Figure 50

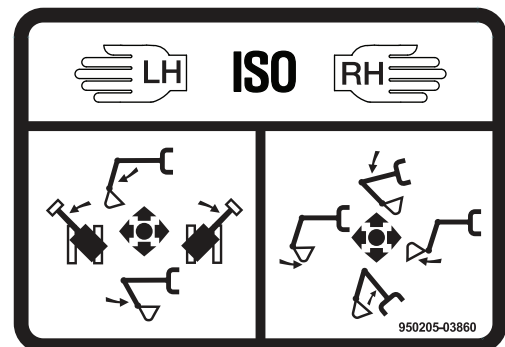

EX1301191

- Do not attempt to start engine by short-circuiting engine starting circuit. This can result in death or serious injury, or fire.
- When starting engine, sound horn as a warning to alert personnel in the work area.

If there is a warning tag or "DO NOT OPERATE" tag hanging from work levers (joysticks) or travel control levers, do not start engine or move levers.

- Prevent personnel from walking or standing under raised boom, unless it is properly supported.

**NOTE:** When starting engine in cold temperatures, "white engine exhaust smoke" from the tail pipe can occur until engine reaches normal operating temperatures.

**NOTE:** Also, a white residue, because of water vapor inside engine, can form at the engine oil fill location. These conditions will not affect engine performance or damage the engine or other exhaust system components.

## Swinging or Traveling

As a machine operator, you should know and follow local, state and federal laws and regulations when operating on public roads or highways.

It is important to keep in mind that the machine, in comparison with the rest of traffic, is a slow moving and wide vehicle which can cause traffic delays. Pay attention to traffic behind you and allow traffic to pass you.

Before operating the machine or work equipment, always observe the following precautions to prevent death or serious injury.

- Check all tires to make sure that they are properly inflated and are not damaged.
- Make sure that all excess mud, stones, etc. has been removed from the tires.
- Fully raise and secure all outriggers and the dozer blade.

**NOTE:** Be sure to "LOCK" the outriggers when traveling.

- Make sure that upper structure is facing forwards with dozer blade in front.
- Store the front attachment in the transport position and set the function lock in the "TRAVEL" position.
- Set the ram cylinder toggle switch in the "UNLOCK" position.
- Before moving the machine, make sure that swing lock pin has engaged. This will prevent the machine from accidentally rotating during traveling.

**Figure 51**

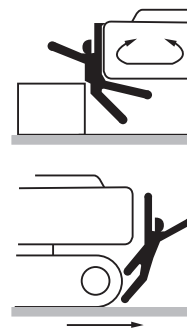

HAOA190L

- When changing travel direction from forward to reverse or from reverse to forward, reduce speed and stop machine before changing travel direction.
- Sound horn to alert people in area.
- Check that there is no one in area around machine. There are restricted visibility areas behind machine so, if necessary, swing upper structure slowly to check that there is no one behind machine before traveling in reverse.
- Before moving the machine, make sure that swing lock pin is "ENGAGED". This will prevent the upper structure from accidentally rotating while traveling.
- When operating in areas with poor visibility, designate a flagman to direct work site traffic.
- Keep unauthorized personnel away from turning radius or travel path of the machine.

Be sure to observe above precautions even if a travel alarm or mirrors are installed.

- Check that travel alarm works properly and that mirrors are clean, not damaged and properly adjusted.
- Always latch door and windows of operator's cabin in position (open or closed).
- On work sites where there is a hazard of flying or falling objects, or of objects entering operator's cabin, check that door and windows are securely closed. Install additional guards, if work site application requires them.

Never turn starter switch to "O" (OFF) position when traveling. This can lead to a loss of steering control.

Do not operate attachments while traveling.

Do not change selected travel mode (FAST/SLOW) while traveling.

Never travel over obstacles or excessive slopes that will cause machine to tilt severely. Avoid any slope or obstacle that can cause machine to tilt 10° or more to right or left, or 30° or more from front to rear.

Do not operate steering controls suddenly. Work equipment can hit ground and this can damage machine or structures in area.

When traveling on rough ground, travel at low speed, and avoid sudden changes in direction.

Always operate within permissible water depth. Permissible water depth is up to bottom of axle housing.

When passing over bridges or structures on private land, check that structure is strong enough to support weight of machine. Before traveling on public roads, check with appropriate authorities and follow their instructions.

**Figure 52**  
Travel Position

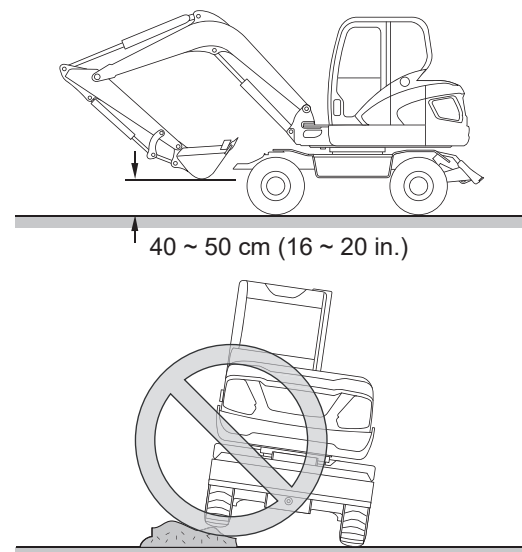

WE1500610

Never exceed maximum permitted load for bridges.

Always operate machine with dozer blade to front under cabin and outriggers to rear.

Know permitted ground pressure. Ground pressure of the machine may change depending on attachment and load.

Keep height and length of attachment in mind.

## **Lifting and Digging**

The operator is responsible for any load carried when traveling on public roads and while working with the machine.

- Keep loads secure so they do not fall off while operating.
- Do not exceed maximum load for the machine. Machine operation will be affected when center of gravity changes, caused by extended loads and different attachments.

To lift loads safely when in digging mode, the following must be evaluated by the operator and work site crew.

- Condition of ground support.
- Excavator configuration and attachments.
- Weight, lifting height and swing radius.
- Safe rigging of load.
- Proper handling of suspended load.

Always watch load. Bring load close to the machine before traveling any distances or swinging load.

Lifting capacity decreases as load is moved further from the machine.

Do not suddenly lower, swing, or stop work equipment.

- Do not move bucket over head of other personnel or over the operator's seat of dump trucks or other hauling equipment. The load may spill or bucket can hit dump truck causing property damage or cause death or serious injury.

## Operation on Slopes

### ⚠ NOTICE

Abnormal operation with half of the brake running, failure to comply with the brake oil change intervals, or excessive service brakes may increase the temperature of the axle oil during the operation, resulting in reduced braking forces. For safety, do not drive at high speeds and overloading on slopes.

If the machine has to be used on a slope, pile soil to make a platform that will keep the machine as horizontal as possible.

Improper traveling on steep slopes could result in machine tipping, roll-over or sliding down the slope. Always fasten your seat belt.

When possible, operate machine up slopes and down slopes. Avoid operating machine across slope.

On hills, banks or slopes, carry bucket approximately 20 ~ 30 cm (8 ~ 12 in) above ground. In case of an emergency, quickly lower bucket to ground to help stop machine.

Do not travel on grass, fallen leaves, or wet steel plates. Even slight slopes can cause machine to slide down a slope. Travel at low speed and make sure that the machine is always traveling directly up or down slope.

Do not change travel direction on a slope. This could result in tipping or sliding sideways of machine.

Improper operation when working on slopes can cause a tip over. Use caution when swinging or operating work equipment on slopes.

Do not swing work equipment from uphill side to downhill side when bucket is loaded. This could cause machine to tip or roll-over.

In addition, lower bucket as far as possible, keep it pulled into front, and keep swing speed as slow as possible.

If the machine begins to slide down on a grade, immediately dump load and turn the machine downhill.

Be careful to avoid any ground condition which could cause the machine to tip. Tipping can occur when you work on hills, on banks, or on slopes. Tipping can also occur when you cross ditches, ridges, or travel over unexpected obstructions.

Keep the machine under control. Do not overload the machine beyond capacity.

- When traveling up a steep slope, extend work equipment to front to improve balance, keep work equipment approximately 20 ~ 30 cm (8 ~ 12 in) above ground, and travel at low speed.

Figure 53

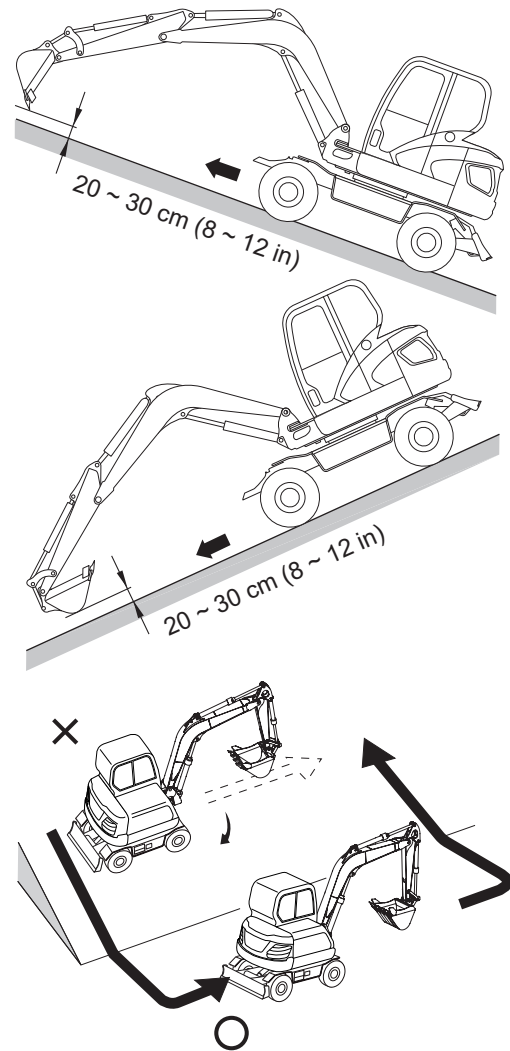

WE1500611

Figure 54

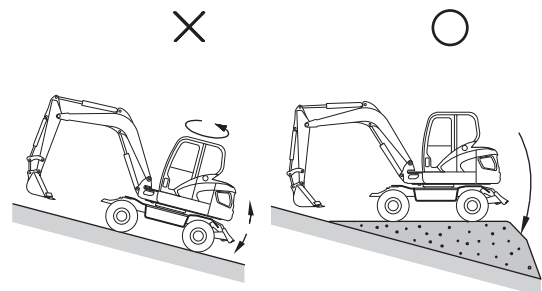

WE1500612

- Do not turn on slopes or travel across slopes. Always go down to a flat place to change position of the machine, then travel backup the slope again.

## Towing

---

### NOTICE

---

Do not tow more than 1.5 times towing machine's own weight. Be careful to secure the wire rope to both sides of the axle so that force is not applied to one side of the axle.

---

To prevent death or serious injury when towing, always do the following:

- Follow the instruction given in this manual.
- Use a wire rope of sufficient strength for towing.
- In the event of slipping into swampy ground or towing heavy objects, use a wire rope to tow the machine as shown in the illustration.
- Put wood blocks between the wire rope and the machine to protect the machine and wire rope from damage.
- Only use the towing hole for light objects.
- Be sure to use shackles. Keep the cable horizontal, straight, and parallel to the tires.
- Select the "LOW" travel mode. Slowly drive the machine when towing.
- When performing preparation work for towing with two or more personnel, determine signals to use and correctly follow these signals.
- Always attach wire rope onto left and right hooks and secure in position.
- If engine on problem machine will not start or there is a failure in brake system, always contact your HYUNDAI distributor.
- Never go between towing machine and towed machine during towing operation.
- Do not perform towing on steep slopes, so select a place where slope is gradual. If there is no place where slope is gradual, perform operations to reduce angle of slope before starting towing operation.
- When towing a machine, always use a wire rope with a sufficient towing capacity.

Figure 55

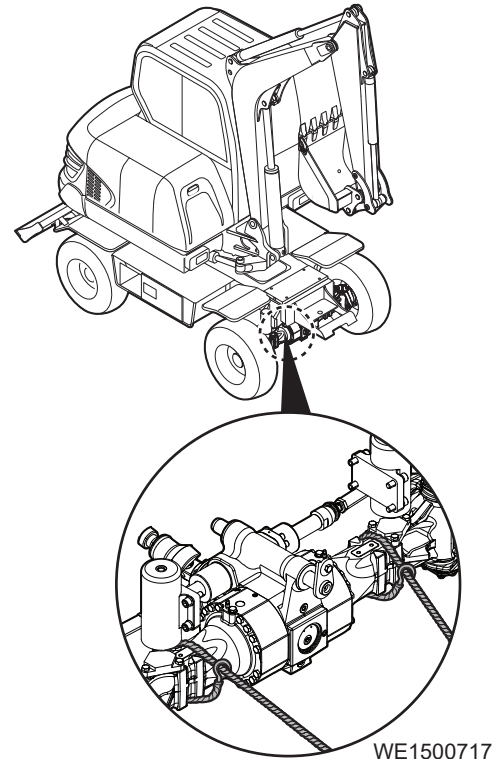

- Do not use a wire rope that is kinked or frayed, or a wire rope with any loss of diameter. Wear leather gloves when handling a wire rope.
- Do not use lightweight towing hook for towing another machine.
- Make sure that towing eyes and towing devices are adequate for towing loads.
- Only connect wire rope to a drawbar or to a hitch.
- Operate the machine slowly and be careful not to apply any sudden load to wire rope.

## Attachment

Never let anyone ride on any work attachment, such as bucket, crusher, grapple, or clamshell (grab bucket). This creates a falling and crushing hazard, and can result in death or serious injury.

The clamshell, grapple, or magnet can swing in all directions. Move work levers (joysticks) in a continuous motion. Failure to move work levers (joysticks) in a continuous motion can cause clamshell, grapple, or magnet to swing into cabin or into a person in work area. This can result in death or serious injury.

- When using a fork or grapple, do not attempt to pick up an object with its tips. This could damage the machine or cause personal injury, if picked-up object slips off attachment.
- Do not use impact force of work equipment for demolition work. This could damage work equipment, cause broken materials to fly off or tipping. This could result in death or serious injury.
- Do not use work equipment or swing mechanism to pull load in any direction. This could cause the work equipment to move suddenly if the load releases and can result in death or serious injury.

## Equipment Lowering with Engine Stopped

Before lowering any equipment with the engine stopped, clear the area around the equipment of all personnel and bystanders. The procedure to use will vary with the type of equipment to be lowered. Keep in mind most systems use a high-pressure fluid or air to raise or lower equipment. The procedure will cause high-pressure air, or hydraulic pressure, or some other media to be released to lower the equipment

## Engine Stop

Turn engine starter switch to "O" (OFF) position and remove engine starter switch key.

Figure 56



EX1400133



Before lowering any equipment with engine stopped, clear area around equipment of all personnel and bystanders. This procedure will cause high-pressure air or hydraulic pressure to be released to lower equipment.

Do not stop engine immediately after the machine has been operated under load. This can cause overheating and accelerated wear of engine components.

After the machine is parked, allow engine to run for five minutes before stopping the engine. This allows hot areas of engine to cool gradually.

- Do not leave operator's seat when there is a raised load.

## Parking Machine

Avoid making sudden stops, or parking machine wherever it happens to be at end of workday. Park machine on firm and level ground away from traffic and away from high walls, drop-offs and any area of potential water accumulation or runoff. If parking on inclines is unavoidable, block tires to prevent movement. Lower bucket or other working attachment completely to ground, or to an overnight support saddle to prevent unintended or accidental movement.

When parking on public roads, provide fences, signs, flags, or lights, and put up any other necessary signs to ensure that passing traffic can see machine clearly. Park machine so machine, flags, signs and fences do not obstruct traffic.

After front attachment has been lowered to an overnight storage position and all switches and operating controls are in "OFF" position, safety lever must be moved to "LOCK" position. This will disable all pilot control functions.

Always close door of operator's cabin and lock all equipment to prevent any unauthorized person from operating the machine.

The hydraulic system remains pressurized, provided accumulator, is charged even when engine is not running. Accumulator pressure should decrease in a short time (approximately one minute). While hydraulic system maintains a charge, hydraulic work tools and machine controls remain functional.

Machine movement will occur if any controls are moved. This can result in death or serious injury.

Always move safety lever to "LOCK" position before stopping the engine or immediately after engine stops running.

Figure 57

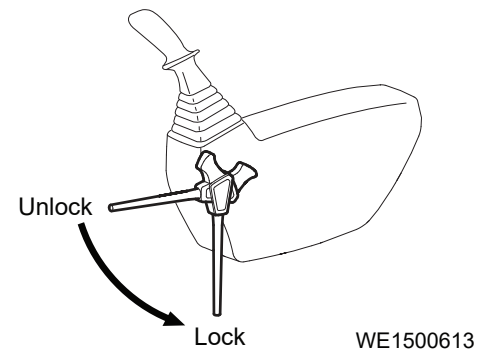
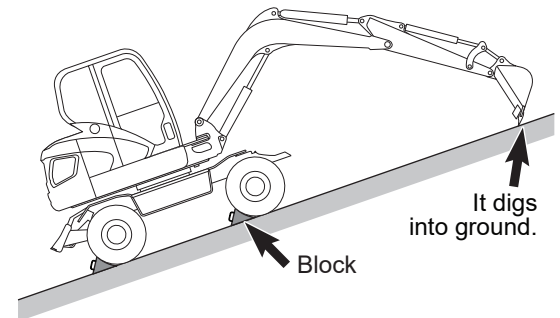
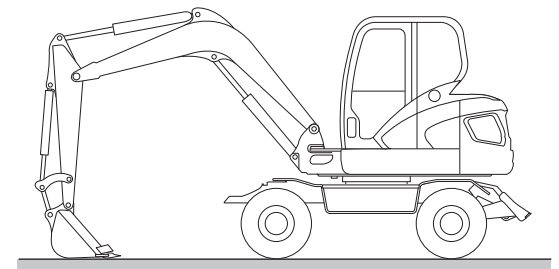

Figure 58



## Service Brake

---

### **WARNING**

---

#### AVOID DEATH OR SERIOUS INJURY

- Before excavating, apply parking brake and depress the service brake pedal and "ENGAGE" the latch mechanism to lock the service brake in the applied position.
  - "LOWER" the dozer blade to the ground before working.
  - When finishing work or parking the machine always "RELEASE" the service brake pedal to prevent damage caused by overheating.
  - Before starting work, always check the condition of the service brakes. Service as necessary.
- 

### **NOTICE**

---

Abnormal operation with half of the brake running, failure to comply with the brake oil change intervals, or excessive service brakes may increase the temperature of the axle oil during the operation, resulting in reduced braking forces.

---

## Preservation/Storing Machine

Perform the following if storing excavator for more than one month.

Conditions	Maintenance Required
Cleaning	Pressure wash lower structure and axle assemblies. Inspect for damage or loose or missing parts.
Lubrication	Perform all daily lubrication procedures.
	Apply a coating of light oil to exposed plated metal surfaces, such as hydraulic cylinder rods, etc.
	Apply a coating of light oil to all control linkages and control cylinders (control valve spools, etc.)
Battery	Turn "OFF" the battery disconnect switch.
Cooling System	Inspect coolant recovery tank to make sure that antifreeze level in system is at correct level.
	Every 90 days, use a hydrometer to measure protection level of coolant. Add coolant as required. Refer to "Antifreeze Concentration Tables" for more information.
Hydraulic System	Once a month, start engine and follow procedures in refer to "Hydraulic System Warm-up" for more information.

1. Complete the preceding steps.
2. Wash machine and touch up paint finish to avoid rusting.

3. Treat exposed parts with antirust agent, lubricate machine thoroughly and apply grease to unpainted surfaces like lifting and tilting cylinders etc.
4. Fill fuel tank and hydraulic oil tank to "FULL" marks.
5. Cover exhaust pipe (parking outside).
6. Make sure that coolant is at proper concentration for expected lowest temperatures.
7. Park machine on level, firm ground where there is no risk of freezing, landslide or flooding. Avoid parking machine on a slope.

Keep in mind that theft and burglary risk can be minimized by:

- Removing starter key when the machine is left unattended.
- Locking doors and covers after working hours.
- Turning off electrical current with battery disconnect switch.
- Park machine where risk of theft, burglary and damage is minimized.
- Removing valuables from cabin such as cellular phone, computer, radio and bags.

#### **Check After Long-term Parking**

- All oil and fluid levels.
- Tension of all belts.
- Air pressure.
- Air cleaner.
- Batteries and electrical connections.
- Lubricate all greasing points.
- Wipe off grease from piston rods.
- Inspect for signs of nests (i.e. birds, rodents, etc.)
- Inspect safety label (decals). Replace if damaged, worn, or missing.

# Transportation

## Obey State and Local Over-the-Road Regulations

Check federal, state and local laws and regulations regarding weight, width and length of a load before making preparations for transporting on public roads or highways.

The hauling vehicle, trailer and load must be in compliance with applicable regulations for the shipping route.

Partial disassembly of excavator may be necessary to meet travel restrictions or particular conditions at work site. See Shop Manual for information on partial disassembly.

Refer to "Transportation" for more information.

The machine can be disassembled into parts for transporting. Contact your HYUNDAI distributor for assistance with disassembly.

## Loading and Unloading

To prevent machine tipping or roll-over when loading or unloading machine, always do the following:

- Perform loading and unloading only on firm and level ground. Maintain a safe distance from edge of road or drop-off.
- Never use work equipment to load or unload machine. The machine may fall or tip over.
- Always use loading ramps of adequate strength and capacity. Be sure that ramps are wide, and long enough to provide a safe loading slope. Take steps to prevent ramps from moving out of position or coming off.
- Clean ramp surfaces so they are free of grease, oil, ice and loose materials. Remove dirt from machine tires, dozer and lower structure. On a rainy day, be careful since ramp surfaces can be slippery.
- Turn auto idle switch "OFF".
- Run engine at low speed and travel slowly.
- When on ramps, do not operate any control lever except for travel lever.
- Never correct your steering on ramps. If necessary, drive off ramps, correct machine direction, then drive back onto ramps.
- When driving up or down ramps, the center of gravity of machine will change suddenly causing the tires to drop down to the ramps or trailer. This will occur at the joint between the ramps and trailer. Travel slowly over this point.
- Cover the exhaust pipe to prevent turbocharger damage. Lock the cabin door and lower the antenna.

- After loading, block each tire and secure the machine with tie-downs of adequate load rating, so the machine cannot move.
- For machines equipped with a cabin, always lock door after loading machine to prevent door from suddenly opening during transportation.

## **Transporting Machine**

When transporting machine on a trailer or truck, do the following:

- The weight, transportation height, and overall length of machine may change depending on work equipment attached to it. Always check the machine dimensions and work equipment's dimensions before transporting.
- When passing over bridges or structures on private land, check that structure is strong enough to support weight of machine. Before traveling on public roads, check with appropriate authorities and follow their instructions.



# Specifications





# General Specifications

# Safety Instructions

---

## **WARNING**

---

### AVOID DEATH OR SERIOUS INJURY

Instructions are necessary before operating or servicing machine. Read and understand the Operation & Maintenance Manual and signs (decals) on machine. Follow warnings and instructions in the manuals when making repairs, adjustments or servicing. Check for correct function after adjustments repairs or service. Untrained operators and failure to follow instructions can cause death or serious injury.

---

# Table of Contents

## General Specifications

Safety Instructions .....	68
General.....	70
Standard Specification .....	71
Performance Tests .....	74
Purpose of Performance Tests .....	74
Kinds of Tests .....	74
Performance Standards .....	74
Precautions for Evaluation of Test Data .....	74
Definition of "Performance Standard" .....	74
Operational Performance Test .....	75
Hydraulic Cylinder Cycle Time .....	75
Driveshaft Revolution Speed .....	76
Swing Speed .....	77
Swing Function Drift Check .....	78
Operational Performance Standard Table.....	80
Approximate Weight of Workload Materials .....	83
Material Weight .....	83

## General

The excavator has three main component sections:

- The Upper Structure
- The Lower Undercarriage and Track Frames
- The Excavator Front-end Attachment

The following illustration identifies main components and their locations.

# Standard Specification

## General Specification

ITEMS		Model	HW100A			
		Config uration	EU10	EU20	EU30	EU40
OPERATING WEIGHT (WITH BUCKET)		kg	11,073	10,682	10,788	10,682
STD BUCKET CAPACITY (ISO)		m <sup>3</sup>	0.28			
ENGINE	RATED POWER	kW/rpm	75 / 2,000			
	MAX. TORQUE	kg.m/rpm	43.8 / 1,400			
SYSTEM PRESSURE (FRONT, TRAVEL/SWING, DOZER)		kg/cm <sup>2</sup>	301			
SWING SPEED		rpm	10			
TRAVEL SPEED (1 <sup>st</sup> Gear)		km/h	5.4 / 16.9 (Travel motor Low/High)			
TRAVEL SPEED (2 <sup>nd</sup> Gear)		km/h	12.9 / 37.4 (Travel motor Low/High)			
GRADEABILITY		%(deg)	39 (21.2)			
DIGGING FORCE (SAE)	BUCKET (ISO / SAE)	kN	58.6 / 51.6			
	ARM (ISO / SAE)	kN	36.5 / 35.6			

WORKING RANGE	MAX. DIGGING REACH	mm	7,820			
	MAX. DIGGING DEPTH	mm	4,245			
	MAX. DIGGING HEIGHT	mm	8,265			
	REAR SWING RADIUS	mm	1,600			
	MIN. SWING RADIUS	mm	3,105 (2,665 Boom swing)			
TRAVEL DIMENSION	OVERALL LENGTH	mm	5,713			
	OVERALL WIDTH	mm	2,450			
	OVERALL HEIGHT	mm	3,945 (to top of the boom, travel position)			
	GROUND CLEARANCE	mm	400			
	WHEEL BASE	mm	2,240			
	TREAD	mm	1,944			
DOZER BLADE(REAR) WIDTH x HEIGHT		mm	2,450x500			
TIRE		spec	Double 8.25-20-14PR			
MIN. TURNING RADIUS (CALCULATED, Double tire)		m	2wheel steer	2wheel steer	4wheel steer	2wheel steer
			5.738	5.738	3.697	5.738
OTHER OPTION ATTACHMENT			?	?	?	?
BUCKET			X	X	X	X
CLAMSHELL PIPING			X	X	X	X
ROTATING PIPING			X	O	O	X
QUICK COUPLER PIPING			O	X	X	X
STEERING TYPE			2Wheel	2Wheel	4Wheel	2Wheel
WHEEL TYPE			Double	Double	Double	Double

CHASSIS-FRONT ATTACHMENT		Dozer	Cradle	Cradle	Cradle
CHASSIS-REAR ATTACHMENT		Outrigger	Dozer	Dozer	Dozer
FENDER		X	X	X	X
OPERATOR PROTECTIVE GUARD		X	X	X	X

# Performance Tests

Use operational performance test procedure to quantitatively check all system and functions on the machine.

## Purpose of Performance Tests

1. To comprehensively evaluate each operational function by comparing the performance test data with the standard values.
2. According to the evaluation results, repair, adjust, or replace parts or components as necessary to restore the machine's performance to the desired standard.
3. To economically operate the machine under optimal conditions.

## Kinds of Tests

1. Base machine performance test is to check the operational performance of each system such as engine, travel, swing, and hydraulic cylinders.
2. Hydraulic component unit test is to check the operational performance of each component such as hydraulic pump, motor, and various kinds of valves.

## Performance Standards

"Performance Standard" is shown in tables to evaluate the performance test data.

## Precautions for Evaluation of Test Data

1. To evaluate not only that test data is correct, but also in what range the test data is.
2. Be sure to evaluate the test data based on the machine operation hours, kinds and state of work loads, and machine maintenance conditions.

The machine performance does not always deteriorate as the working hours increase. However, the machine performance is normally considered to reduce in proportion to the increase of the operation hours. Accordingly, restoring the machine performance by repair, adjustment, or replacement shall consider the number of the machine's working hours.

## Definition of "Performance Standard"

1. Operation speed values and dimensions of the new machine.
2. Operational performance of new components adjusted to specifications. Allowable errors will be indicated as necessary.



# Operational Performance Test

## Hydraulic Cylinder Cycle Time

### Summary

1. Check the overall operational performance of the front attachment hydraulic system (between the hydraulic pumps and each cylinder) by measuring the cycle time of the boom, arm, bucket, and bucket dump (open/close) cylinders with the empty bucket.
2. Bucket must be empty.

### Preparation

1. Maintain the hydraulic oil temperature at  $50 \pm 5 \text{ }^\circ\text{C}$  ( $122 \pm 41 \text{ }^\circ\text{F}$ ).

Engine Control Dial	Power Mode Switch	Work Mode	Auto-idle Switch
High Idle	Power Plus Mode	Digging Mode	OFF

2. Position the front attachment as described in the following. Then, measure the operating time until cylinder reaches the stroke end by fully moving the control lever.

#### A. Boom cylinder

##### 1) Boom up speed

Rapidly operate the bucket from the ground, and measure the time it takes for the boom to reach the end point.

##### 2) Boom down speed

Rapidly operate the bucket with the boom reached the end point, and measure the time it takes for the bucket to reach the ground.

##### 3) Measuring available displacement of the cylinder:

Measure and record the extension of the cylinder rod from when the bucket is resting on the ground to when the boom cylinder is extended to its maximum length.

#### B. Arm cylinder

##### 1) Arm crowd speed

Rapidly operate the arm while kept fully dumped (extended), and measure the time it takes for the arm to fold fully.

##### 2) Arm dump speed

Rapidly operate the arm maintained in the fully folded position, and measure the time it takes for the arm to extend fully.

##### 3) Measuring available displacement of the cylinder:

Measure and record the extension length of the cylinder rod from the point at which the arm cylinder is fully

Figure 59

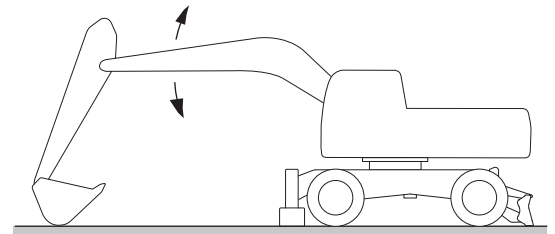

WE1400777

Figure 60

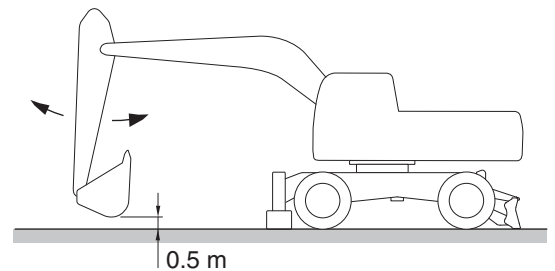

WE1400778

extended (crowded) to the point at which the arm cylinder is fully folded (dumped).

### C. Bucket cylinder

#### 1) Bucket crowd speed

Rapidly operate the bucket while fully dumped (extended), and measure the time it takes for the bucket to fold fully.

#### 2) Bucket dump speed

Rapidly operate the bucket while fully folded, and measure the time it takes for the bucket to extend fully.

#### 3) Measuring available displacement of the cylinder: Measure and record the extension length of the cylinder rod from the point at which the bucket cylinder is fully extended (crowded) to the point at which the bucket cylinder is fully folded (dumped).

**NOTE:** Jack up the dozer of the wheel-type excavator and mini-excavator pointing forward, and measure the time taken to jack it up and to jack it back down. Measure and record the operating time of the boom swing (option) of the mini-excavator from right to left, or from left to right.

**NOTE:** Record the details of any abnormal noise heard during measurement, or any abnormal conditions observed during operation, on a blank measurement record sheet.

Figure 61

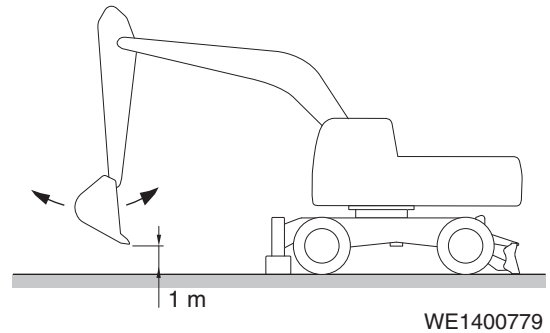

## Driveshaft Revolution Speed

### Summary

Measure the drive shaft revolution cycle time with jack up condition.

### Preparation

1. Position the front attachment as described in Figure 62.
2. Jack up the machine with dozer and outrigger.

Figure 62

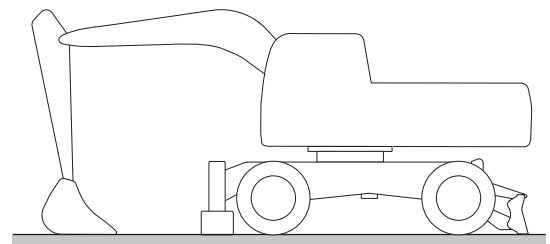

---

**⚠ CAUTION**

---

#### AVOID INJURY

Position the machine on firm and level ground not to be tilted.

---

WE1400816

3. Prepare a tachometer to measure driveshaft revolution.  
(Figure 63)

**Figure 63**

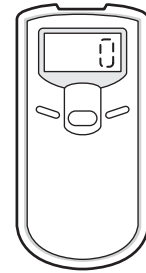

WE1400817

**Measurement**

1. Set the machine to correspond with measuring conditions.
2. Measure conditions are as below.

Travel Mode	Power Mode	Engine Idle	Travel Switch
ON	ON	High Idle	1st
ON	ON	High Idle	2nd

3. Start engine and accelerate with accelerator pedal to operate drive shaft.
4. Measure the revolution of drive shaft by tachometer.
5. Perform the measurement three times and calculate the average values.

**NOTE:** Record the details of any abnormal noise heard during measurement, or any abnormal conditions observed during operation, on a blank measurement record sheet.

**Figure 64**

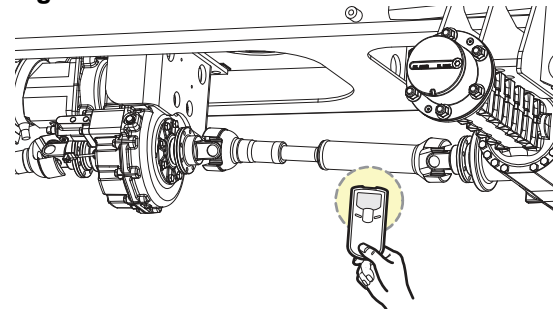

WE1501128

**Swing Speed**

**Summary**

Measure the time required to swing three complete turns.

**Preparation**

1. Check the lubrication of the swing gear and swing bearing.
2. Place the machine on flat, solid ground with ample space for swinging. Do not conduct this test on slopes.
3. With the bucket empty, position the front attachment as follows. With the arm cylinder fully retracted, and the bucket cylinder fully extended, raise the boom so bucket pin height is flush with the boom foot pin height.

**NOTE:** In case of no place to be measured, measure with the boom raised and the arm rolled-in.

4. Maintain the hydraulic oil temperature at 50 ±5°C (122 ±41°F).

**Figure 65**

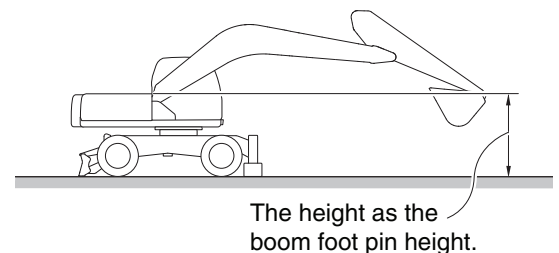

WE1400780

---

## CAUTION

---

### AVOID INJURY

Prevent personal injury. Always make sure that area is clear and that co-workers are out of the swing area before starting the measurement.

---

### Measurement

1. Measurement conditions are as below.

Engine Control Dial	Power Mode Switch	Work Mode	Auto-idle Switch
High Idle	Power Plus Mode	Digging Mode	OFF

2. Operate swing control lever fully.
3. Measure the time required to swing 3 turns in one direction. (Record the stopwatch measurement to the second decimal place.)
4. Operate swing control lever fully in the opposite direction and measure the time required for 3 turns.
5. Perform the measurement three times and calculate the average values.

### Evaluation

Refer to Operational Performance Standard Table on page 1-1.

## Swing Function Drift Check

### Summary

Measure the swing drift on the bearing outer circumference when stopping after a 360° full-speed swing.

### Preparation

1. Check the lubrication of the swing gear and swing bearing.
2. Place the machine on flat, solid ground with ample space for swinging. Do not conduct this test on a slope.
3. With the bucket empty, position the front attachment as follow. With the arm cylinder fully retracted, and the bucket cylinder fully extended, raise the boom so bucket pin height is flush with the boom foot pin height.
4. Put the matching marks on the swing bearing and on the track frame by using a tape, as illustrated.

**Figure 66**

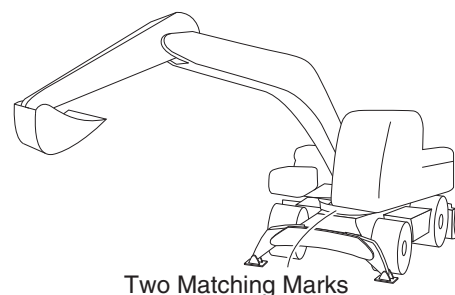

WE1400781

- Swing the upper structure 360°.
- Maintain the hydraulic oil temperature at  $50 \pm 5^{\circ}\text{C}$  ( $122 \pm 41^{\circ}\text{F}$ ).

---

**⚠ CAUTION**

---

**AVOID INJURY**

Prevent personal injury. Always make sure that area is clear and that co-workers are out of the swing area before starting the measurement.

---

**Figure 67**

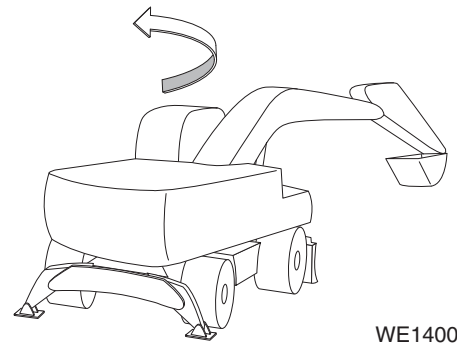

WE1400782

**Measurement**

- Measurement conditions are as below.

Engine Control Dial	Power Mode Switch	Work Mode	Auto-idle Switch
High Idle	Power Plus Mode	Digging Mode	OFF

- Operate swing control lever fully and return it to the neutral position when the mark on upper structure aligns with that on track frame after swinging 360°.
- Measure the time distance between the two marks.
- Align the marks again, swing 360°, and then test in the opposite direction.
- Perform the measurement three times and calculate the average values.

**Figure 68**

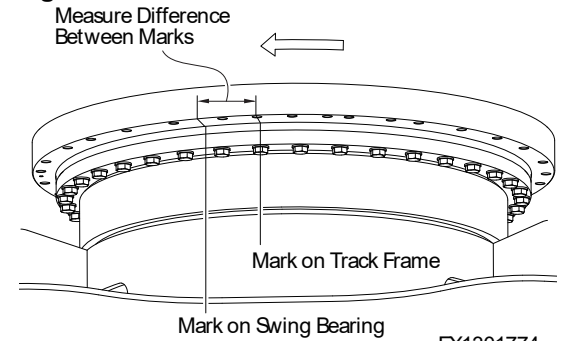

EX1301774

**Evaluation**

Refer to Operational Performance Standard Table on page 1-1.

# Operational Performance Standard Table

Item	Model		Unit	Measuring Conditions	Performance Standard	Tolerance	
Engine Speed	Working Mode	Power+ Mode	rpm	SPC Off	-	-	
			rpm	SPC Off + A/I On	-	-	
			rpm	SPC On	-	-	
		Power Mode	rpm	SPC Off	2,000	±25	
			rpm	SPC Off + A/I On	-	-	
			rpm	SPC On	-	±25	
		Standard Mode	rpm	SPC Off	1,800	±25	
			rpm	SPC On	-	±25	
		Economy Mode	rpm	SPC Off	1,600	±25	
			rpm	SPC On	-	±25	
		Lifting Mode	rpm	Dial Max.	1,400	±25	
		Low Idle	Above Coolant Temp. 15°C	rpm	Dial Min.	1,000	±25
			Below Coolant Temp. 15°C	rpm		1,000	±25
		Auto Idle	Above Air Temp. 10°C	rpm	A/I On	1,200	±25
			Below Air Temp. 10°C	rpm		1,200	±25
	Working Mode	Relief Load	1 Pump	rpm	*Standard	-	Above
			2 Pump	rpm		-	Above
			3 Pump	rpm		-	-
		Boom Up or Arm Dump Operation Load	Power+ Mode	rpm	Dial Max., Sudden Command.	-	Above
			Power Mode	rpm		2,000	±25
			Standard Mode	rpm		1,800	±25
			Economy Mode	rpm		1,600	±25
			1300 rpm	rpm	Max. Power Mode, Adjust Dial, Sudden Command	1,300	±25
		Low Idle	rpm	Dial Min., Sudden Command	Not Stop Engine		
	Fan Revolution		rpm	*Standard	2,500	±50	

Item	Model			Unit	Measuring Conditions	Performance Standard	Tolerance	
EPOS	EPPR Valve Current for Pump	Working Mode	Power+ Mode	mA	Dial Max., Sudden Command, Minimum Value at Arm Crowd	-	-	
			Power Mode	mA		-	-	
			Standard Mode	mA		-	-	
			Economy Mode	mA		-	-	
			Lifting Mode	mA		-	-	
			Low Idle	mA		Dial Min.	-	-
			Auto Idle	mA	A/I On	-	-	
Pressure Set	Main	Pump 1 & 2	Normal	bar	*Standard	295 (LS: 280)	0~+10	
			Boost	bar		-	0~+10	
		Pump 3	Normal	bar		-	-	
	Swing	Relief (at Motor)		bar	*Standard	215	0~+10	
		Relief (at Pump)		bar	*Standard	250 (LS: 235)	0~+10	
	Travel	Relief (at Pump)		bar	*Standard	430	0~+10	
	Option	1 Way Relief		bar	*Standard, 150 lpm, 220 bar.	-	-	
		2 Way Relief		bar		LS: 230	±25	
		Rotating Relief		bar	*Standard	LS: 200	±25	
	Front Speed	Boom	Up		sec	*Standard, Sudden Command.	3.4	±0.3
Down			sec	-	-			
Down (with Lock Valve)			sec	3.1	±0.3			
Arm		Crowd		sec	-		-	
		Crowd (with Lock Valve)		sec	2.9		±0.3	
		Dump		sec	2.7		±0.2	
Bucket *Wheel Type		Crowd		sec	2.5		±0.3	
		Dump		sec	2.1		±0.2	
Arti.		Up		sec	4.0		±0.6	
		Down		sec	-		-	
Outrigger		Up		sec	2.1		±0.4	
		Down		sec	2.5		±0.4	
Dozer		Up		sec	*Standard, Actuator Speed at Machine Jack-up		2.1	±0.2
		Down		sec	2.5		±0.2	
Swing Speed	Fine Swing off			sec	*Standard, Max. Reach Position, Empty Bucket, 3 Rotations Time & Swing Coasting After Max. Swing Speed	17.2	±1.6	
	Swing Coasting			mm		416	±146	

Item	Model		Unit	Measuring Conditions	Performance Standard	Tolerance
Travel	Travel Speed	1st Gear, Motor Max.	km/h	Power Mode	5.8	±0.6
		1st Gear, Motor Min.	km/h		17.2	±1.7
		2nd Gear, Motor Max.	km/h		13.9	±1.4
		2nd Gear, Motor Min.	km/h		37.6	±3.8
	Track Speed With Jack-up	1st Gear, Motor Max.	km/h	Travel Power Mode	6.0	±0.6
		1st Gear, Motor Min.	km/h		17.0	±1.7
		2nd Gear, Motor Max.	km/h		14.0	±1.4
		2nd Gear, Motor Min.	km/h		40.0	±4
Cylinder Creeping	Front	Boom Down	mm/5 min	Max. Reach, Bucket Crowd posture, (50 mm cylinder lift for Arm & Bucket to avoid cushion) Weight: General Purpose Machine – with 1.5 Times of Bucket Capacity, Special Purpose Machine – with 3.5 Ton Weight	5	Below
		Arm Crowd	mm/5 min		5	Below
		Bucket Dump	mm/5 min		20	Below
		Arti. Boom Down	mm/5 min		5	Below
	Lower	Dozer Down	mm/5 min	*Standard	5	Below

- Standard Condition: Lever On, Digging Mode, Max. Power Mode, Engine Dial Max., SPC Off, A/I Off, A/C Off, Hydraulic Oil 45 ±5°C, Coolant 80 ±5°C



# Approximate Weight of Workload Materials

## NOTICE

Weights are approximations of estimated average volume and mass. Exposure to rain, snow or groundwater; settling or compaction because of overhead weight and chemical or industrial processing or changes because of thermal or chemical transformations could all increase value of weights listed in table.

### Material Weight

The data below describes weight of a cubic meter (cubic yard) of many types of workload materials.

Material	Density 1,200 kg/m <sup>3</sup> (2,000 lb/yd <sup>3</sup> ), or less	Density 1,500 kg/m <sup>3</sup> (2,500 lb/yd <sup>3</sup> ), or less	Density 1,800 kg/m <sup>3</sup> (3,000 lb/yd <sup>3</sup> ), or less	Density 2,100 kg/m <sup>3</sup> (3,500 lb/yd <sup>3</sup> ), or less
Charcoal	401 kg/m <sup>3</sup> (695 lb/yd <sup>3</sup> )	-	-	-
Coke, blast furnace size	433 kg/m <sup>3</sup> (729 lb/yd <sup>3</sup> )	-	-	-
Coke, foundry size	449 kg/m <sup>3</sup> (756 lb/yd <sup>3</sup> )	-	-	-
Coal, bituminous slack, piled	801 kg/m <sup>3</sup> (1,350 lb/yd <sup>3</sup> )	-	-	-
Coal, bituminous r. of m., piled	881 kg/m <sup>3</sup> (1,485 lb/yd <sup>3</sup> )	-	-	-
Coal, anthracite	897 kg/m <sup>3</sup> (1,512 lb/yd <sup>3</sup> )	-	-	-
Clay, DRY, in broken lumps	1,009 kg/m <sup>3</sup> (1,701 lb/yd <sup>3</sup> )	-	-	-
Clay, DAMP, natural bed	-	-	1,746 kg/m <sup>3</sup> (2,943 lb/yd <sup>3</sup> )	-
Cement, portland, DRY granular	-	-	1,506 kg/m <sup>3</sup> (2,583 lb/yd <sup>3</sup> )	-
Cement, portland, DRY clinkers	-	1,362 kg/m <sup>3</sup> (2,295 lb/yd <sup>3</sup> )	-	-
Dolomite, crushed	-	-	1,522 kg/m <sup>3</sup> (2,565 lb/yd <sup>3</sup> )	-

<b>Material</b>	<b>Density 1,200 kg/m<sup>3</sup> (2,000 lb/yd<sup>3</sup>), or less</b>	<b>Density 1,500 kg/m<sup>3</sup> (2,500 lb/yd<sup>3</sup>), or less</b>	<b>Density 1,800 kg/m<sup>3</sup> (3,000 lb/yd<sup>3</sup>), or less</b>	<b>Density 2,100 kg/m<sup>3</sup> (3,500 lb/yd<sup>3</sup>), or less</b>
Earth, loamy, DRY, loose	-	1,202 kg/m <sup>3</sup> (2,025 lb/yd <sup>3</sup> )	-	-
Earth, DRY, packed	-	-	1,522 kg/m <sup>3</sup> (2,565 lb/yd <sup>3</sup> )	-
Earth, WET, muddy	-	-	1,762 kg/m <sup>3</sup> (2,970 lb/yd <sup>3</sup> )	-
Gypsum, calcined, (heated, powder)	961 kg/m <sup>3</sup> (1,620 lb/yd <sup>3</sup> )	-	-	-
Gypsum, crushed to 3 inch size	-	-	1,522 kg/m <sup>3</sup> (2,565 lb/yd <sup>3</sup> )	-
Gravel, DRY, packed fragments	-	-	-	1,810 kg/m <sup>3</sup> (3,051 lb/yd <sup>3</sup> )
Gravel, WET, packed fragments	-	-	-	1,922 kg/m <sup>3</sup> (3,240 lb/yd <sup>3</sup> )
Limestone, graded above 2	-	1,282 kg/m <sup>3</sup> (2,160 lb/yd <sup>3</sup> )	-	-
Limestone, graded 1-1/2 or 2	-	1,362 kg/m <sup>3</sup> (2,295 lb/yd <sup>3</sup> )	-	-
Limestone, crushed	-	-	1,522 kg/m <sup>3</sup> (2,565 lb/yd <sup>3</sup> )	-
Limestone, fine	-	-	1,602 kg/m <sup>3</sup> (2,705 lb/yd <sup>3</sup> )	-
Phosphate, rock	-	1,282 kg/m <sup>3</sup> (2,160 lb/yd <sup>3</sup> )	-	-
Salt	929 kg/m <sup>3</sup> (1,566 lb/yd <sup>3</sup> )	-	-	-
Snow, light density	529 kg/m <sup>3</sup> (891 lb/yd <sup>3</sup> )	-	-	-
Sand, DRY, loose	-	-	1,522 kg/m <sup>3</sup> (2,565 lb/yd <sup>3</sup> )	-
Sand, WET, packed	-	-	-	1,922 kg/m <sup>3</sup> (3,240 lb/yd <sup>3</sup> )
Shale, broken	-	1,362 kg/m <sup>3</sup> (2,295 lb/yd <sup>3</sup> )	-	-
Sulfur, broken	529 kg/m <sup>3</sup> (891 lb/yd <sup>3</sup> )	-	-	-

# Engine Specifications

# Safety Instructions

---

## **WARNING**

---

### AVOID DEATH OR SERIOUS INJURY

Instructions are necessary before operating or servicing machine. Read and understand the Operation & Maintenance Manual and signs (decals) on machine. Follow warnings and instructions in the manuals when making repairs, adjustments or servicing. Check for correct function after adjustments repairs or service. Untrained operators and failure to follow instructions can cause death or serious injury.

---

# Table of Contents

## Engine Specifications

Safety Instructions .....	86
Engine Specification .....	88
Engine Performance Curves .....	89
Tightening Torques .....	90
Normal Tightening Torque. . . . .	90

# Engine Specification

Items		Specification
Engine	Type	Water-cooled, Direct Injection
	Emission	EU Stage V
	Model	D34
	Rated Net Power	75 kW (102 PS) @ 2,000 rpm (ISO 14396)
Number of Cylinders		4
Displacement		3,409 cc
Compression Ratio		18 : 1
Low Idle Speed		1,000 ± 10 rpm
Max. Full Load Speed		2,000 ± 25 rpm
Weight, without Coolant and Oil		365 kg (804 lb)
Cooling System	Coolant Temperature	90 ~ 95°C
	Number of Thermostats	1
	Thermostat, Opening Temperature	80°C
Electrical System	Type	12 V, DC
	Starter Motor (Standard Equipment)	12 V, 2.5 kW
	Alternator (Standard Equipment)	12 V, 140 A

# Engine Performance Curves

Figure 69

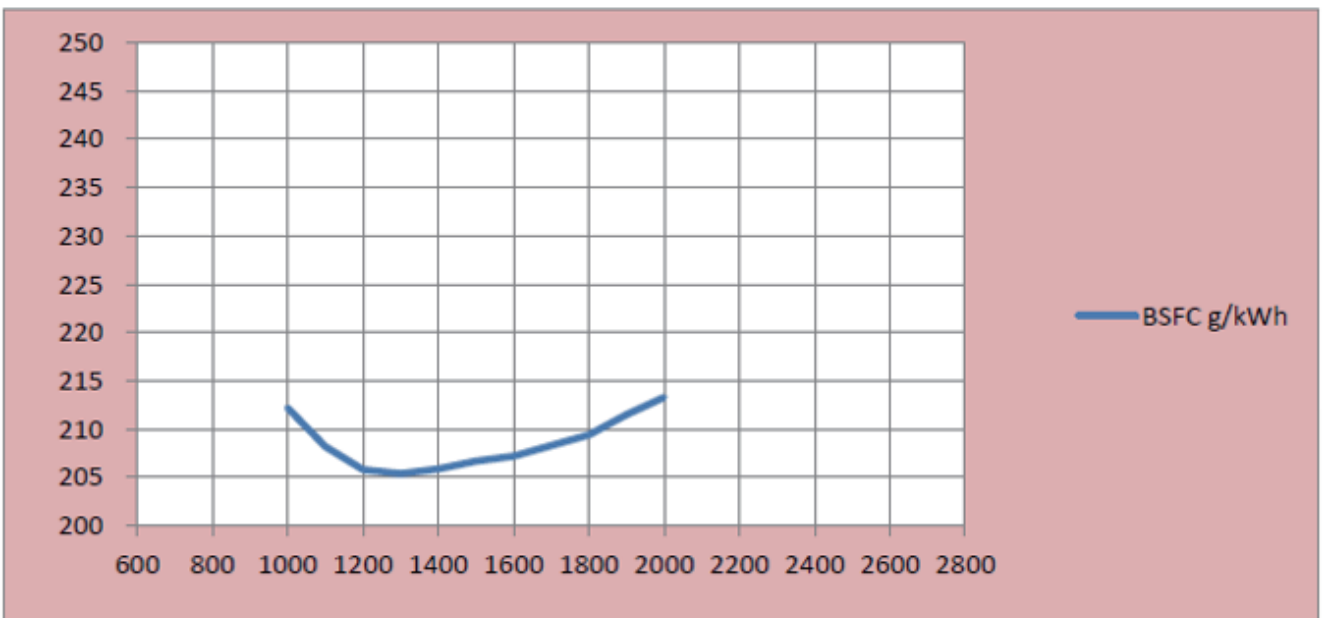
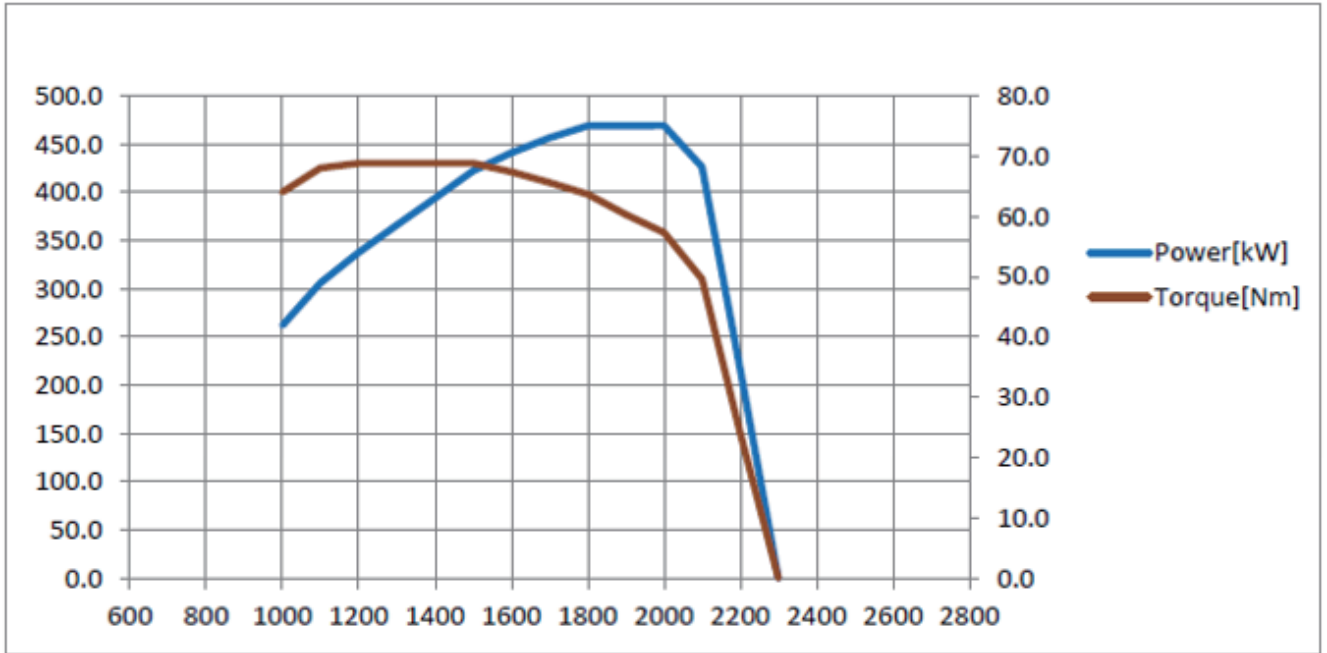

DS2105391

**NOTE:** Barometric Pressure: 760 mm (30") Mercury

Temperature: 20°C (68°F)

W/O Cooling Fan

Alternator: 12V, 140A

Exhaust System: Complete, attached

Air Cleaner, Installed

# Tightening Torques

## Normal Tightening Torque

The specifications in the tables below show the normal tightening torque for screws, nuts and unions. The values are to be used unless other values are specified in the inspection information. Always check whether there are special tightening torques given in the descriptions for the respective areas in the inspection information before using the general values for normal and special tightening torques respectively.

The following conditions apply:

- A tolerance of  $\pm 15\%$  applies to all values unless otherwise specified.
- All contact surfaces are to be clean and free of paint.
- Bolts and nuts are normally not lubricated regardless of surface treatment. All exceptions are specified in the inspection information.

### Union Assemblies

The specified values apply with a tolerance of  $\pm 5\%$ . The values apply to tightening with a counterhold.

### Thread Inserts

The specified tightening torques also apply to bolted joints with a thread insert (Heli-Coil).

Thread inserts often provide greater strength compared to a directly screwed thread. This generates a stronger bolted joint in aluminium or the like.

**NOTE:** *When a damaged thread is repaired with a thread insert, the normal screw and prescribed tightening torque are to be maintained. Install the thread insert as instructed in the inspection information.*

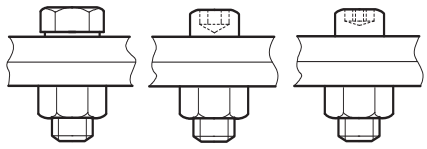
Hexagonal Screws, Hexagon Socket Screws, Six-point Socket Screws, Hexagon Nuts (Metric Thread, Course Pitch)		
Thread	Strength Class 8.8/8 Tightening Torque (Nm)	
M4	2.4	 <p style="text-align: right;">FG020238</p>
M5	5	
M6	8	
M8	20	
M10	39	
M12	70	
M14	112	
M16	180	
M18	240	
M20	350	
M22	490	
M24	600	



Flange Screws with Hexagonal Head and Hexagonal Flange Nuts (Metric Thread, Course Pitch)		
Thread	Strength Class 8.8/8 Tightening Torque (Nm)	
M5	5.4	
M6	8.6	
M8	22	
M10	42	
M12	77	
M14	123	
M16	184	
FG020239		
Thread Forming Six-point Socket Screws and Hexagon Screws with Captive Washer (Modified Metric Thread, Course Pitch)		
Thread	Class 8	Class 10
	Tightening Torque (Nm)	
M4	2.9	-
M6	9.4	11
M8	24	26
M10	47	49
M12	80	85
FG020240		
Thread Forming Six-point Socket Screws ST Thread		
Thread	Tightening Torque (Nm)	
ST2.9	1.1	
ST3.5	1.9	
ST4.2	3.1	
ST4.8	4.5	
ST5.5	7.1	
ST6.3	9.7	
FG020241		
Stud Tap End in Threaded Hole, Strength Class 8.8/8 (Metric Thread, Course Pitch)		
<p>Tightening the stud tap end in the threaded hole must be done so the stud does not come loose when undoing the nut. To tighten the stud in the threaded hole, the torque must just overcome the friction in the thread and generate a preload. The torque for locking is 50% of the normal torque for hexagonal screws, hexagon socket screws, six-point socket screws, hexagon nuts.</p>		FG020242
Union Nuts for Ferrule		

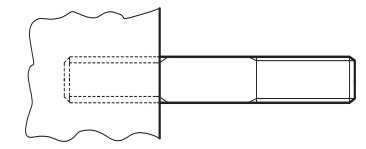
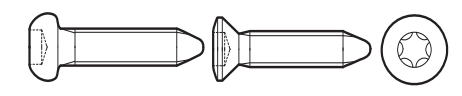
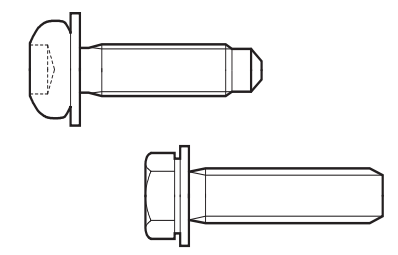
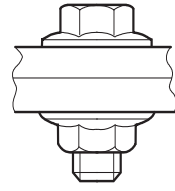

Thread	Thread Tightening Torque ( ±15% Nm)			
	For Pipe Diameter	Steel Pipe with Greased Steel Nut	Plastic Pipe with Steel Ferrule and Brass or Steel Nut	Plastic Pipe with Brass Ferrule and Nut with Rubber Seal
M10x1	5	15	10	-
M12x1.5	6	20	10	-
M14x1.5	8	30	20	-
M16x1.5	10	40	25	15
M18x1.5	12	50	30	20
M20x1.5	12	55	35	-
M24x1.5	16	60	50	40
M130x2	22	120	-	-

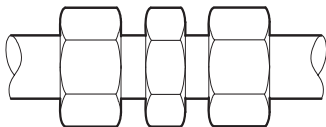

FG020243

Nuts for Lead-in Union	
Thread	Thread Tightening Torque ( ±15% Nm)
M12x1.5	20
M14x1.5	25
M16x1.5	35
M18x1.5	50
M24x1.5	70
M130x2	80

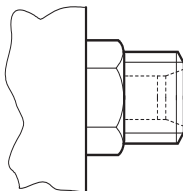

FG020244

Unions with Tapered Thread for Port Connection		
Thread	Thread Tightening Torque ( ±15% Nm)	Tightening Torque (Nm)
	Straight Unions	Elbow Unions
M10x1k	10	8
M12x1.5k	10	8
M14x1.5k	15	10
M16x1.5k	15	10
M18x1.5k	20	15
M20x1.5k	25	20
M22x1.5k	25	20
M26x1.5k	45	40

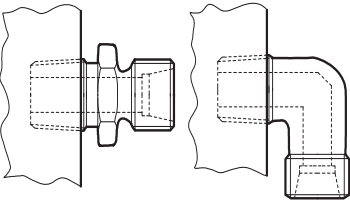

FG020245

Unions, Plugs and Banjo Screws with Cylindrical Threads for Seal with Flat Copper Gasket	
--	--

Thread	Thread Tightening Torque ( ±15% Nm)	 <p>EX1301802</p>
M8x1	10	
M10x1	20	
M12x1.5	20	
M14x1.5	25	
M16x1.5	30	
M18x1.5	35	
M20x1.5	45	
M22x1.5	50	
M24x1.5	60	
M26x1.5	70	
M28x1.5	80	
M30x1.5	110	
M30x2	115	
M32x1.5	115	
M36x1.5	160	
M38x1.5	170	
M45x1.5	270	

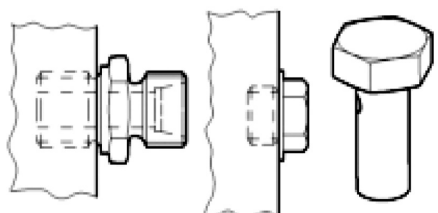
Plugs with Tapered Thread

Thread	Thread Tightening Torque ( ±15% Nm)	 <p>FG020247</p>
M10x1k	15	
M12x1.5k	20	
M14x1.5k	20	
M16x1.5k	25	
M18x1.5k	40	
M20x1.5k	40	
M22x1.5k	40	
M26x1.5k	60	

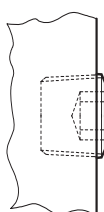
Insert Connections for Port Connection

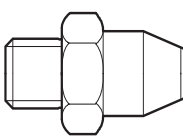
Thread	Thread Tightening Torque ( ±15% Nm)	 <p>FG020248</p>
M10x1k	18	
M12x1.5k	24	
M14x1.5k	28	
M16x1.5k	35	
M22x1.5k	40	

Insert Connections for Union Connection

Thread	For pipe Diameter	Thread Tightening Torque ( ±15% Nm)
M14x1.5k	4-8	10
M18x1.5k	12	15
M24x1.5k	16	25

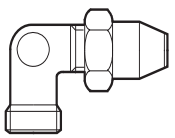

FG020249

# Hydraulic Systems and Structure Specifications

# Safety Instructions

---

## **WARNING**

---

### AVOID DEATH OR SERIOUS INJURY

Instructions are necessary before operating or servicing machine. Read and understand the Operation & Maintenance Manual and signs (decals) on machine. Follow warnings and instructions in the manuals when making repairs, adjustments or servicing. Check for correct function after adjustments repairs or service. Untrained operators and failure to follow instructions can cause death or serious injury.

---

# Table of Contents

## Hydraulic Systems and Structure Specifications

Safety Instructions .....	96
Hydraulic System .....	98
Main Pump .....	98
Performance Curves .....	98
Pilot Pump .....	98
Travel pump (HST) .....	99
Main Control Valve .....	99
Solenoid Valve .....	99
Accumulator for Pilot .....	99
Swing Device .....	100
Travel Device .....	101

# Hydraulic System

## Main Pump

Displacement	100 cc/rev
Rated Speed	2,000 rpm
Max. Flow	200 L/min

## Performance Curves

P - Q Curve

Figure 70

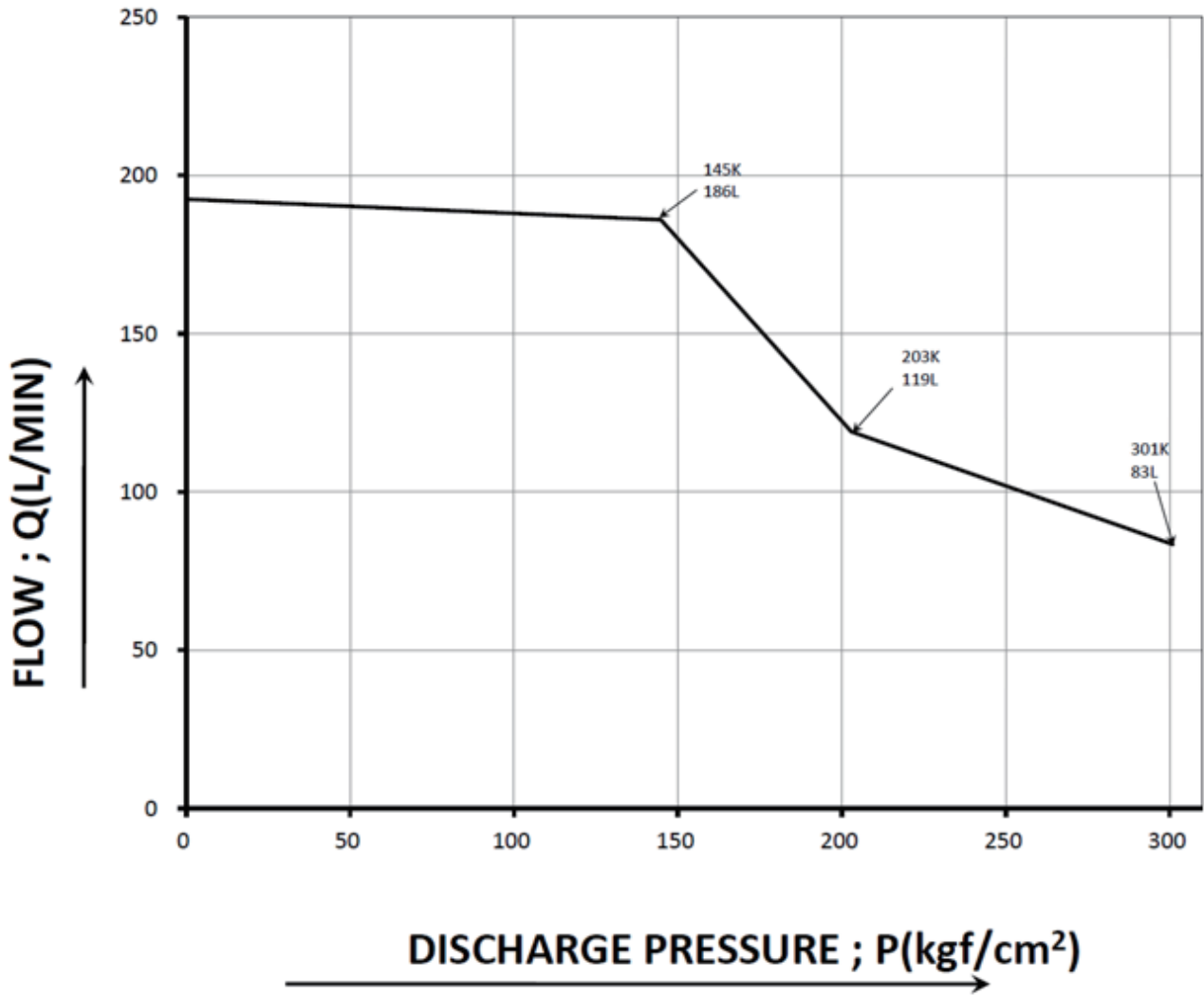

DS2105392

## Pilot Pump

Type	Gear
Max. Flow	23.2 liter/min
Displacement	11.6 cc/rev



## Travel pump (HST)

Type	Axial Piston
Rated Flow Rate	112 liter/min
Max. Displacement	56 cc/rev
Relief Valve setting	438 kgf/cm <sup>2</sup> (430 bar)
Pressure Cut-off	438 kgf/cm <sup>2</sup> (430 bar)

## Main Control Valve

Control Type	Section, Load sensing
No. of Spools	9
Spool Diameter	18 mm
LS Relief Pressure	286 kgf/cm <sup>2</sup> (280 bar)
System Pressure	301 kgf/cm <sup>2</sup> (295 bar)

## Solenoid Valve

Rated Capacity	DC 12 V, 22W
----------------	--------------

## Accumulator for Pilot

System	Charge Pressure	Volume
Pilot	10 bar (142 psi) (10 kg/cm <sup>2</sup> )	0.75 Liter (0.16 gal)

## Swing Device

### Swing Motor

Displacement	53.1 cc/rev
Crossover Relief Valve Setting	220 kg/cm <sup>2</sup>
Max. Supply Flow	75 liter/min
Motor Shaft Torque	18.6 kgf.m)
Rotation Speed	1,412 rpm

### Swing Reduction Gear

Drive Type	2 - Stage Planetary Gear
Reduction Ratio	19.464
Max. Output Speed	72.6 rpm
Max. Output Torque	361.9 kgf.m

### Pinion Gear

Type	Spur Gear
Gear P.C.D	Φ 96mm
No.of Teeth	12
Module	8

### Swing Bearing

Type	Ball Bearing, Internal Gear
Gear P.C.D	Φ 656 mm
No.of Teeth	82
Ball Diameter	Φ 28.575 mm
Race O.D.	Φ 950 mm
Static Thrust Load	10,500 kg

### Parking Brake

Type	Mechanical
Brake Torque	3347.2 kgf.m
Brake Release Pressure	Min. 15 bar, Max. 30 bar <sup>2</sup>

## Travel Device

### Travel Motor

Type	Axial Piston
Displacement	34 ~ 107 cc/rev
Max. Supply Flow	112 liter/min
Motor Shaft Torque	66.27 kgf.m
Motor Shaft Speed	2,973 rpm

### Transmission

Type	2 Speed
Reduction Ratio	1.14 / 2.75
Max. Input Torque	83.6 kgf.m
Motor Shaft Speed	3,500 rpm

### Front Axle

Type	Fully Floating Planetary Gear
Reduction Ratio	12.8
Axle Load (Dynamic load capacity)	7,000 kg
Axle Load (Static load capacity)	14,000 kg
Wheel Bolt P.C.D	Ø275 mm
Brake Type	Multiple Wet Disc
Brake Torque	1,610 kgf.m
Steering Angle	35°
Steering Cylinder Stroke	85.07 mm
Steering Cylinder Operating Pressure	184 kgf/cm <sup>2</sup>

### Rear Axle - 2 Wheel Steering Option

Type	Fully Floating Planetary Gear
Reduction Ratio	12.8
Axle Load (Dynamic load capacity)	7,000 kg
Axle Load (Static load capacity)	14,000 kg
Wheel Bolt P.C.D	Ø275 mm
Brake Type	Multiple Wet Disc
Brake Torque	1,610 kgf.m

### Rear Axle - 4 Wheel Steering Option

Type	Fully Floating Planetary Gear
Reduction Ratio	12.8
Axle Load (Dynamic load capacity)	7,000 kg
Axle Load (Static load capacity)	14,000 kg
Wheel Bolt P.C.D	Ø275 mm
Brake Type	Multiple Wet Disc

Brake Torque	1,610 kgf.m
--------------	-------------

**Parking Brake - Standard**

Type	Main Pressure, Mechanical
Brake Torque	Min. 27.6 kgf.m (199.2 lbf.ft)
Brake Release Pressure	10.2 kg/cm <sup>2</sup> (145 psi) (1 MPa)

**Tire & Wheel - Double tire**

Tire	8.25-20-14PR
Rim	6.5-20
Disc Offset	135 mm

**Tire & Wheel - Single tire**

Tire	500/45-20
Rim	16-20
Disc Offset	33.5 mm

**Brake System & Pressure**

System	Full Hydraulic, Dual line
Service Brake Pressure	50 kg/cm <sup>2</sup>

# General Maintenance



# General Maintenance Instructions

# Safety Instructions

---

## **WARNING**

---

### AVOID DEATH OR SERIOUS INJURY

Instructions are necessary before operating or servicing machine. Read and understand the Operation & Maintenance Manual and signs (decals) on machine. Follow warnings and instructions in the manuals when making repairs, adjustments or servicing. Check for correct function after adjustments repairs or service. Untrained operators and failure to follow instructions can cause death or serious injury.

---



# Table of Contents

## General Maintenance Instructions

Safety Instructions .....	106
Welding Precautions and Instructions .....	108
Hydraulic System - General Precautions .....	110
Maintenance Service and Repair Procedure.....	112
General Precautions . . . . .	112
Hydraulic System Cleanliness and Oil Leaks .....	113
Maintenance Precautions for Hydraulic System Service	113
Oil Leakage Precautions . . . . .	113
Cleaning and Inspection .....	115
General Instructions . . . . .	115
Bearing Inspection. . . . .	116

# Welding Precautions and Instructions

---

## **WARNING**

---

### AVOID DEATH OR SERIOUS INJURY

To avoid accidents, personal injury and the possibility of causing damage to the machine or to components, welding must only be performed by properly trained and qualified personnel, who possess the correct certification (when required) for the specific welding fabrication or specialized repair being performed.

---

---

## **WARNING**

---

### AVOID DEATH OR SERIOUS INJURY

Structural elements of the machine may be built from a variety of steels. These could contain unique alloys or may have been heat-treated to obtain particular strength characteristics. It is extremely important that welding repairs on these types of steel are performed with the proper procedures and equipment. If repairs are performed incorrectly, structural weakening or other damage to the machine (that is not always readily visible) could result. Always consult HYUNDAI After Sales Service before welding on integral components of the machine. It is possible that some types of structurally critical repairs may require Magnetic Particle or Liquid Penetrant testing, to make sure there are no hidden cracks or damage, before the machine can be returned to service.

---

---

## **WARNING**

---

### AVOID DEATH OR SERIOUS INJURY

Always perform welding procedures with proper safety equipment and adequate ventilation in a dry work area. Keep a fire extinguisher near and wear personal protective equipment.

---

---

 **WARNING**

---

**AVOID DEATH OR SERIOUS INJURY**

Observe the following safety instructions:

1. Use adequate safety shielding and keep away from fuel and oil tanks, batteries, hydraulic piping lines or other fire hazards when welding.
  2. Never weld when the engine is running. Battery cables must be disconnected before the welding procedure is started.
  3. Never weld on a wet or damp surface. The presence of moisture causes hydrogen embrittlement and structural weakening of the weld.
  4. If welding procedures are being performed near cylinder rods then, operator's cabin window areas or any other assemblies could be damaged by weld spatters. Use adequate shielding protection in front of the assembly.
  5. During welding equipment setup, always attach ground cables directly to the area or component being welded to prevent arcing through bearings, bushings, or spacers.
  6. Always use correct welding rods for the type of weld being performed and observe recommended precautions and time constraints. AWS Class E7018 welding rods for low alloy to medium carbon steel must be used within two hours after removal from a freshly opened container. Class E11018G welding rods for T-1 and other higher strength steel must be used within 1/2 hour of removal from a freshly opened container.
-

## Hydraulic System - General Precautions

Always maintain oil level in the system at recommended levels. Assemblies that operate under heavy loads, at high-speed, with extremely precise tolerances between moving parts (e.g. pistons and cylinders, or shoes and swash plates), can be severely damaged if oil supply runs dry.

Assemblies can be run dry and damaged severely in a very short time when piping or hoses are disconnected to repair leaks and/or replace damaged components. Hoses that are inadvertently switched during disassembly (inlet for outlet and vice versa), air introduced into the system or assemblies that are low on oil because of neglect or careless maintenance, could all produce sufficient fluid loss to cause damage or improper operation.

When starting the engine (particularly after long layoff or storage intervals), make sure that all hydraulic controls and operating circuits are in neutral, or "OFF". That will prevent pumps or other components that may be temporarily oil starved from being run under a load.

Replacement of any hydraulic system component could require thorough cleaning, flushing, and some amount of refilling with fresh, clean oil if the protective seal on replacement parts has obviously been broken or if seal integrity may have been compromised. When protective seals are removed before installation and reassembly, inspect all replacement parts carefully before they are installed. If the replacement part shows no trace of factory pre-lube or has been contaminated by dirt or by questionable oils, flushing and refilling with clean hydraulic fluid is recommended.

Vibration, irregular or difficult movement or unusual noise from any part of the hydraulic system could be an indication of air in the system (and many other types of problems). As a general precaution (and to help lessen the risk of potential long-term damage), allow the engine to run at no-load idle speed immediately after initial start-up. Hydraulic fluid will circulate, releasing any air that may have been trapped in the system before load demands are imposed.

Before starting the machine, a daily walk-around safety inspection, including a quick visual inspection for any exterior evidence

of leaking hydraulic fluid, can help extend the service life of system components.

---

## **NOTICE**

---

Hydraulic system operating conditions (repetitive cycling, heavy workloads, fluid circulating under high-pressure) make it extremely critical that dust, grit or any other contamination be kept out of the system. Observe fluid and filter change maintenance interval recommendations and always pre-clean any exterior surface of the system before it is exposed to air. For example, the reservoir fill cap and neck area, hoses that have to be disassembled, and the covers and external surfaces of filter canisters should all be cleaned before disassembly.

---

# Maintenance Service and Repair Procedure

## General Precautions

Fluid level and condition should always be checked whenever any other maintenance service or repair is being performed.

**NOTE:** *If the unit is being used in an extreme temperature environment (in subfreezing climates or in high temperature, high humidity tropical conditions), frequent purging of moisture condensation from the hydraulic reservoir drain tap must be a regular and frequent part of the operating routine. In more moderate, temperate climates, draining reservoir sediment and moisture may not be required more than once or twice every few months.*

Inspect drained oil and used filters for signs of abnormal coloring or visible fluid contamination at every oil change. Abrasive grit or dust particles will cause discoloration and darkening of the fluid. Visible accumulations of dirt or grit could be an indication that filters are overloaded (and will require more frequent replacement) or that disintegrating bearings or other component failures in the hydraulic circuit may be imminent or have already occurred. Open the drain plugs on the main pump casings and check and compare drain oil in the pumps. Look for evidence of grit or metallic particles.

Vibration or unusual noise during operation could be an indication of air leaking into the circuit (Refer to the appropriate Troubleshooting section for component or unit for procedures.), or it may be evidence of a defective pump. The gear type pilot pump could be defective, causing low pilot pressure, or a main pump broken shoe or piston could be responsible.

**NOTE:** *If equipped, indicated operating pressure, as shown on the multidisplay digital gauge on the Instrument Panel ("F-Pump" and "R-Pump") will be reduced because of a mechanical problem inside the pump. However, pressure loss could also be because of cavitation or air leakage, or other faults in the hydraulic system.*

Check the exterior case's oil drain line in the main pumps. If no metallic particles are found, make sure there is no air in the system. Unbolt and remove tank return drain line from the top part of the swing motor, both travel motors and each main pump. If there is air in any one of the drain lines, carefully prefill the assembly before bolting together the drain line piping connections. Run the system at low rpm.

# Hydraulic System Cleanliness and Oil Leaks

## Maintenance Precautions for Hydraulic System Service

Whenever maintenance, repairs or any other troubleshooting or service is being performed, it's important to remember that hydraulic system - including both the interior and exterior surfaces of assemblies, and every drop of operating fluid - must be protected from contamination.

Dust and other foreign contaminants are major contributors to premature wear in hydraulic circuits. The narrow tolerances, rapidly moving parts and high operating pressures of the system require that fluid be kept as clean as possible. The performance and dependability of the machine (and the service life of individual components) can be noticeably reduced if proper precautions are not observed:

- Use a noncombustible, evaporative type, low residue solvent and thoroughly clean exterior surfaces of assemblies before any part of the circuit is opened or disassembled.

**NOTE:** *It's just as important to clean the cap and reservoir top before routine fluid changes or quick checks as it is before major repairs. (Accumulated dirt attracts moisture, oil and other fluids - and more dirt.)*

- Keep dismantled parts covered during disassembly. Use clean caps, plugs or tape to protect the disconnected openings of flanges, manifolds and piping.
- Do not allow cleaning solvents or other fluids to mix with the oil in the system. Use clean oil to flush any traces of solvent or other residue before reassembly.
- If metal or rubber fragments are found in the system, flush and replace all fluid in the system and troubleshoot the circuit to identify the source of contamination.

---

### NOTICE

---

Make sure that cleaning solvents will be compatible with rubber materials used in the hydraulic system. Many petroleum based compounds can cause swelling, softening, or other deterioration of system sealing elements, such as O-rings, caps and other seals.

---

## Oil Leakage Precautions

Oil that is visibly seeping from joints or seals should always serve as a "red flag" alarm.

Leaks must alert the machine operator and maintenance crew that air, water and dirt have an open, free passageway through

which to enter the circuit. Corrosive salt air, freezing and thawing condensation cycles and working environments that are full of fine dust are especially hazardous. Clogging of valve spools or external piping (especially pilot circuit piping) can gradually diminish or suddenly put a stop to normal hydraulic function. You can prevent having to make these types of repairs by the following recommended assembly procedures:

1. Use new O-rings and oil seals whenever hydraulic assemblies are rebuilt.
2. Prepare joint surfaces before assembly by checking alignment and flatness. Clean and repair corrosion or any other damage.
3. Follow bolt torque recommendations and all other assembly requirements.

**NOTE:** *Grease lip seals before assembly.*

**Figure 71**

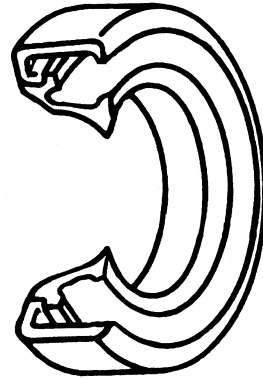

0565A



# Cleaning and Inspection

## General Instructions

All parts must be clean to permit an effective inspection. During assembly, it is very important that no dirt or foreign material enters unit being assembled. Even minute particles can cause malfunction of close installed parts such as thrust bearing, matched parts, etc.

---

### **WARNING**

---

#### AVOID DEATH OR SERIOUS INJURY

Do not inhale vapors or allow solvent type cleaners to contact skin. Keep solvent away from open flame, arcs or sparks or other sources of ignition that could start a fire.

---

1. Clean all metal parts thoroughly using a suitable cleaning fluid. It is recommended that parts be immersed in cleaning fluid and moved up and down slowly until all oils, lubricants, and/or foreign materials are dissolved and parts are thoroughly clean.
2. For bearings that can be removed, soak them in a suitable cleaning fluid for a minute or two, then remove bearings from cleaning fluid and strike flat against a block of wood to dislodge solidified particles of lubricant. Immerse again in cleaning fluid to flush out particles. Repeat above operation until bearings are thoroughly clean. To dry bearings, use moisture-free compressed air. Be careful to direct air stream across bearing to avoid spinning bearings that are not lubricated. **DO NOT SPIN BEARINGS WHEN DRYING**; bearings may be rotated slowly by hand to facilitate drying process.
3. Carefully inspect all bearing rollers, cages, and cups for wear, chipping, or nicks to determine condition. Do not replace a bearing cone or cup individually without replacing the mating cup or cone at the same time. After inspection, dip bearings in lightweight oil and wrap them in clean lintless cloth or paper to protect them until installation.

For those bearings that are to be inspected in place; inspect bearings for roughness of rotation, scoring, pitting, cracked or chipped races. If any of these defects are found, replace bearings. Also, inspect defective bearing housing and/or shaft for grooved, galled or burred conditions that indicate bearing has been turning in its housing or on its shaft.

4. It is more economical to replace oil seals, O-rings, sealing rings, gaskets and retaining rings when unit is disassembled than waiting for premature failures; refer to latest Micro Fiche and/or Parts Book for replacement items. Be careful when installing sealing members, to avoid cutting or scratching. Curling under of any seal lip will seriously impair its efficiency. Apply a thin coat of Loctite #120 to outer diameter of metal casing and on oil seals to assure an oil tight install into retainer. Use extreme care not to get Loctite on lips of oil seals. If this

happens, that portion of the seal will become brittle and allow leakage.

When replacing lip type seals, make sure spring loaded side is towards oil to be sealed.

5. If available, use magna-flux or similar process for checking for cracks that are not visible. Examine teeth on all gears carefully for wear, pitting, chipping, nicks, cracks or scores. Replace all gears showing cracks or spots where case-hardening has worn through. Small nicks may be removed with suitable hone. Inspect shafts and quills to make certain they have not been sprung, bent, or no twisted splines, and that shafts are normal condition.

**NOTE:** *Spline wear is not considered detrimental except where it affects tightness of splined parts.*

Inspect thrust washers for distortion, scores, burs, and wear. Replace thrust washer if defective or worn.

6. Inspect bores and bearing surfaces of cast parts and machined surfaces for scratches, wear, grooves and dirt. Remove any scratches and burrs with crocus cloth. Remove foreign material. Replace any parts that are deeply grooved or scratched which would affect their operation.

## **Bearing Inspection**

The conditions of the bearing are vital to the smooth and efficient operation of the machinery. When any component containing bearings is disassembled, always carefully examine the condition of the bearings and all of its components for wear and damage.

Once the bearing is removed, clean all parts thoroughly using a suitable cleaning solution. If the bearing is excessively dirty, soak the bearing assembly in a light solution and move the bearing around until all lubricants and/or foreign materials are dissolved and the parts are thoroughly clean.

When drying bearings, moisture free compressed air can be used. Be careful not to direct the air in a direction which will force the bearing to dry spin while not being properly lubricated.

After the bearings have been cleaned and dried, carefully inspect all bearing rollers, cages and cups for wear, chipping or nicks. If the bearing cannot be removed and is to be inspected in place, check for roughness of rotation, scoring, pitting, cracked or chipped races. If any of these defects are found replace the whole bearing assembly. NEVER replace the bearing alone without replacing the mating cup or the cone at the same time.

After inspection lightly coat the bearing and related parts with oil and wrap in a clean lintless cloth or paper and protect them from moisture and other foreign materials until installation.

It is also important to inspect the bearing housing and/or shaft for grooved, galled or burred conditions that indicate the bearing has been turning in its housing or on its shaft.

If available, use magna-flux or similar process for checking for cracks that are not visible.

The following illustrations will aid in identifying and diagnosing some of the bearing related problems.

**NOTE:** *The illustrations will only show tapered roller bearings, but the principles of identifying, diagnosing and remedying the defects are common to all styles and types of bearings.*

**Normal Bearing**

Smooth even surfaces with no discoloration or marks.

**Figure 72**

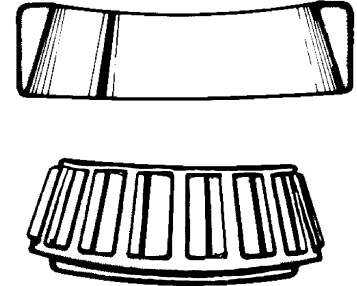

HASA620S

**Bent Cage**

Cage damage because of improper handling or tool usage.

Replace bearing.

**Figure 73**

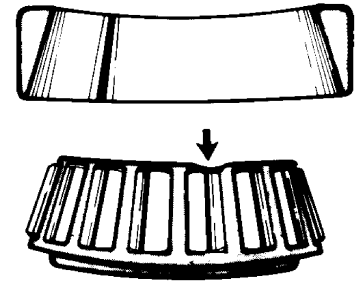

HASA460S

## Galling

Metal smears on roller ends because of overheating, lubricant failure or overload.

Replace bearing - check seals and check for proper lubrication.

Figure 74

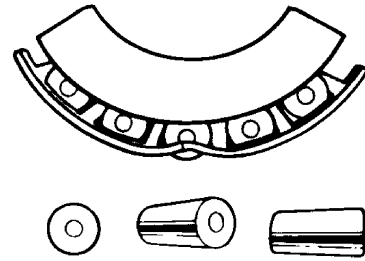

HASA470S

Figure 75

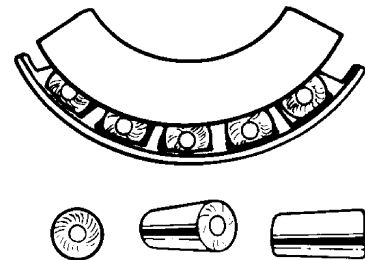

HASA480S

## Abrasive Step Wear

Pattern on roller ends caused by fine abrasives.

Clean all parts and housings, check all parts and housings, check seals and bearings and replace if leaking, rough or noisy.

Figure 76

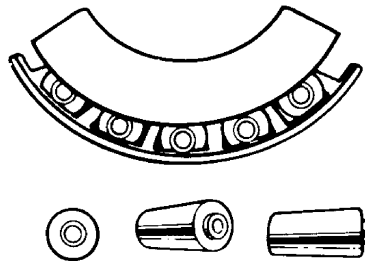

HASA490S

## Etching

Bearing surfaces appear gray or grayish black in color with related etching away of material usually at roller spacing.

Replace bearings - check seals and check for proper lubrication.

Figure 77

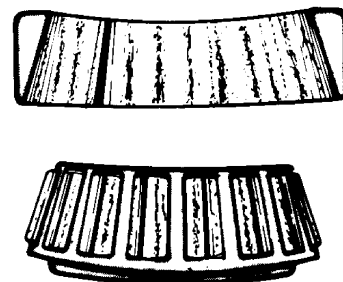

HASA500S

**Misalignment**

Outer race misalignment because of foreign object.  
Clean related parts and replace bearing. Make sure races are properly seated.

**Figure 78**

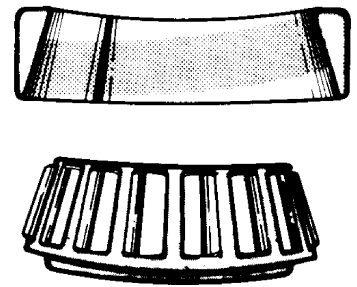

HASA510S

**Indentations**

Surface depressions on race and rollers caused by hard particles of foreign materials.  
Clean all parts and housings, check seals and replace bearings if rough or noisy.

**Figure 79**

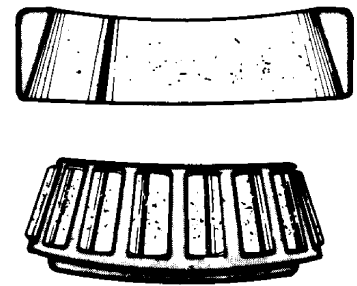

HASA520S

**Fatigue Spalling**

Flaking of surface metal resulting from fatigue.  
Replace bearing - clean all related parts.

**Figure 80**

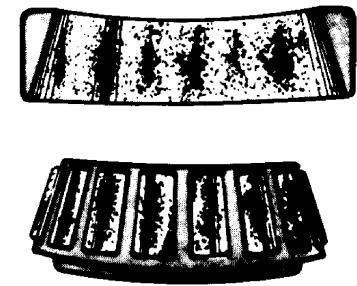

HASA530S

**Brinelling**

Surface indentations in raceway caused by rollers either under impact loading or vibration while the bearing is not rotating.  
Replace bearing if rough or noisy.

**Figure 81**

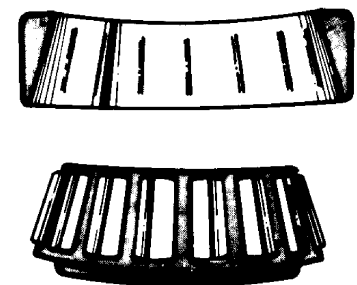

HASA540S

### Cage Wear

Wear around outside diameter of cage and roller pockets caused by abrasive material and inefficient lubrication.

Replace bearings - check seals.

Figure 82

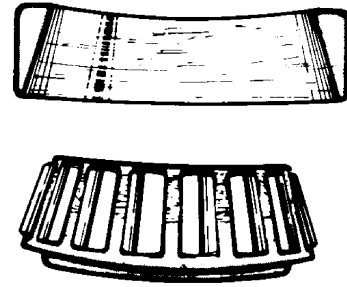

HASA550S

### Abrasive Roller Wear

Pattern on races and rollers caused by fine abrasives.

Clean all parts and housings, check seals and bearings and replace if leaking, rough or noisy.

Figure 83

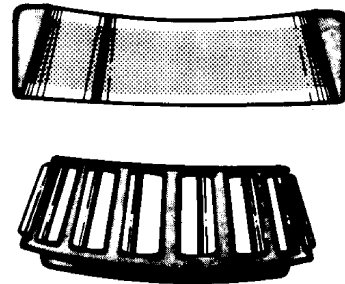

HASA560S

### Cracked Inner Race

Race cracked because of improper installation, cocking or poor bearing seat.

Replace all parts and housings, check seals and bearings and replace if leaking.

Figure 84

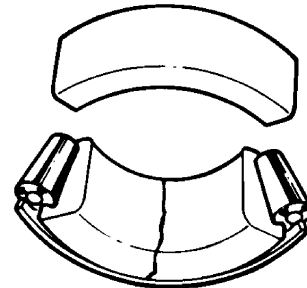

HASA570S

### Smears

Smearing of metal because of slippage caused by poor installation, lubrication, overheating, overloads or handling damage.

Replace bearings, clean related parts and check for proper installation and lubrication.

Replace shaft if damaged.

Figure 85

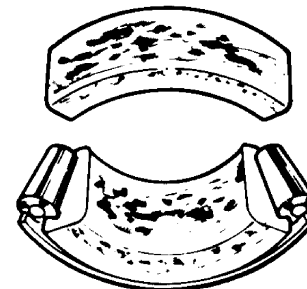

HASA580S

**Frettage**

Corrosion set up by small relative movement of parts with no lubrication.

Replace bearing. Clean all related parts. Check seals and check for proper lubrication.

**Figure 86**

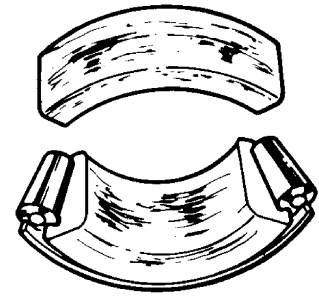

HASA590S

**Heat Discoloration**

Heat discoloration can range from faint yellow to dark blue resulting from overload or incorrect lubrication.

Excessive heat can cause softening of races or rollers.

To check for loss of temper on races or rollers, a simple file test may be made. A file drawn over a tempered part will grab and cut metal, whereas a file drawn over a hard part will glide readily with no metal cutting.

Replace bearing if overheating damage is indicated. Check seals and other related parts for damage.

**Figure 87**

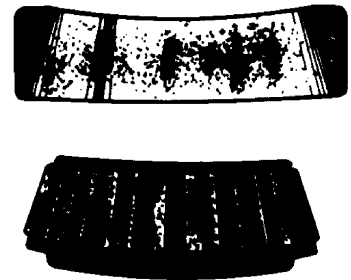

HASA600S

**Stain Discoloration**

Discoloration can range from light brown to black caused by incorrect lubrication or moisture.

If the stain can be removed by light polishing or if no evidence of overheating is visible, the bearing can be reused.

Check seals and other related parts for damage.

**Figure 88**

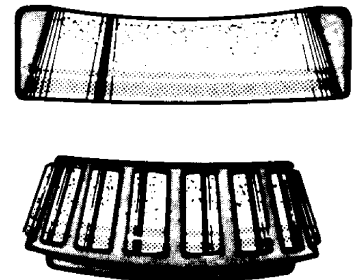

HASA610S





# Standard Torques

# Safety Instructions

---

## **WARNING**

---

### AVOID DEATH OR SERIOUS INJURY

Instructions are necessary before operating or servicing machine. Read and understand the Operation & Maintenance Manual and signs (decals) on machine. Follow warnings and instructions in the manuals when making repairs, adjustments or servicing. Check for correct function after adjustments repairs or service. Untrained operators and failure to follow instructions can cause death or serious injury.



---

# Table of Contents

## Standard Torques

Safety Instructions .....	124
Torque Values for Standard U.S. Fasteners .....	126
Type 8 Phosphate Coated Hardware .....	129
Torque Values for Hose Clamps .....	130
ORFS Swivel Nut Recommended Torque.....	131
Torque Values for Split Flanges .....	132
Torque Wrench Extension Tools .....	133
Torque Multiplication . . . . .	133
Other Uses for Torque Wrench Extension Tools. . . . .	134
Tightening Torque Specifications (Metric). . . . .	134

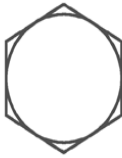
# Torque Values for Standard U.S. Fasteners

Type	SAE Grade	Description	Bolt Head Marking
1	1 or 2	WILL HAVE NO MARKINGS IN THE CENTER OF THE HEAD. Low or Medium Carbon Steel Not Heat-treated.	
5	5	WILL HAVE THREE RADIAL LINES. Quenched and Tempered Medium Carbon Steel.	
8	8	WILL HAVE 6 RADIAL LINES. Quenched and Tempered Special Carbon or Alloy Steel.	

Recommended torque, in foot-pounds, for all Standard Application Nuts and Bolts, provided:

1. All thread surfaces are clean and lubricated with SAE-30 engine oil. (See Note.)
2. Joints are rigid, that is, no gaskets or compressible materials are used.
3. When reusing nuts or bolts, use minimum torque values.

**NOTE:** *Multiply the standard torque by:*

0.65 When finished jam nuts are used.

0.70 When Molykote, white lead or similar mixtures are used as lubricants.

0.75 When Parkerized bolts or nuts are used.

0.85 When cadmium plated bolts or nuts and zinc bolts w/waxed zinc nuts are used.

0.9 When hardened surfaces are used under the nut or bolt head.

**NOTE:** *When reusing bolts and nuts in service, use minimum torque values.*

The following General Torque Values must be used where SPECIAL TORQUE VALUES are not given.

**NOTE:** *Torque values listed throughout this manual are lubricated (wet) threads; values must be increased 1/3 for non lubricated (dry) threads.*

Thread Size	Heat-treated Material Grade 5 and Grade 8			
	Grade 5 (3 Radial Dashes on Head)		Grade 8 (6 Radial Dashes on Head)	
	Foot pounds (ft lb)	Newton Meter (Nm)	Foot pounds (ft lb)	Newton Meter (Nm)
1/4" - 20	6	8	9	12
1/4" - 28	7	9	11	15
5/16" - 18	13	18	18	24
5/16" - 24	15	20	21	28
3/8" - 16	24	33	34	46
3/8" - 24	27	37	38	52
7/16" - 14	38	52	54	73
7/16" - 20	42	57	60	81
1/2" - 13	58	79	82	111
1/2" - 20	65	88	90	122
9/16" - 12	84	114	120	163
9/16" - 18	93	126	132	179
5/8" - 11	115	156	165	224
5/8" - 18	130	176	185	251
3/4" - 10	205	278	290	393
3/4" - 16	240	312	320	434
7/8" - 9	305	414	455	617

**NOTE:** Torque values listed throughout this manual are lubricated (wet) threads; values must be increased 1/3 for non lubricated (dry) threads.

Thread Size	Heat-treated Material Grade 5 and Grade 8			
	Grade 5 (3 Radial Dashes on Head)		Grade 8 (6 Radial Dashes on Head)	
	Foot pounds (ft lb)	Newton Meter (Nm)	Foot pounds (ft lb)	Newton Meter (Nm)
7/8" - 14	334	454	515	698
1" - 8	455	617	695	942
1" - 14	510	691	785	1064
1 1/8" - 7	610	827	990	1342
1 1/8" - 12	685	929	1110	1505
1 1/4" - 7	860	1166	1400	1898
1 1/4" - 12	955	1295	1550	2102
1 3/8" - 6	1130	1532	1830	2481
1 3/8" - 12	1290	1749	2085	2827
1 1/2" - 6	1400	2034	2430	3295
1 1/2" - 12	1690	2291	2730	3701
1 3/4" - 5	2370	3213	3810	5166
2" - 4 1/2	3550	4813	5760	7810

**NOTE:** If any bolts and nuts are found loose or at values less than what the chart states, it is recommended that loose bolt and/or nut be replaced with a new one.

## Type 8 Phosphate Coated Hardware

This chart provides tightening torque for general purpose applications using original equipment standard hardware as listed in the Parts Manual for the machine involved. DO NOT SUBSTITUTE. In most cases, original equipment standard hardware is defined as Type 8, coarse thread bolts, nuts and thru hardened flat washers (Rockwell "C" 38 - 45), all phosphate coated and assembled without supplemental lubrication (as received) condition.

The torques shown below also apply to the following:

1. Phosphate coated bolts used in tapped holes in steel or gray iron.
2. Phosphate coated bolts used with phosphate coated prevailing torque nuts (nuts with distorted threads or plastic inserts).
3. Phosphate coated bolts used with copper plated weld nuts.

Markings on bolt heads or nuts indicate material grade ONLY and are NOT to be used to determine required torque.

Nominal Thread Diameter	Standard Torque $\pm 10\%$	
	Kilogram.meter (kg.m)	Foot pounds (ft lb)
1/4"	1.1	8
5/16"	2.2	16
3/8"	3.9	28
7/16"	6.2	45
1/2"	9.7	70
9/16"	13.8	100
5/8"	19.4	140
3/4"	33.2	240
7/8"	53.9	390
1"	80.2	580
1 - 1/8"	113.4	820
1 - 1/4"	160.4	1160
1 - 3/8"	210.2	1520
1 - 1/2"	279.4	2020
1 - 3/4"	347.1	2510
2"	522.8	3780

## Torque Values for Hose Clamps

The following chart provides the tightening torques for hose clamps used in all rubber applications (radiator, air cleaner, operating lever boots, hydraulic system, etc.).

Clamp Type and Size	Torque			
	Radiator, Air Cleaner, Boots, Etc.		Hydraulic System	
	Kilogram.meter (kg.m)	Inch Pounds (in lb)	Kilogram.meter (kg.m)	Inch Pounds (in lb)
"T" Bolt (Any Diameter)	0.68 - 0.72	59 - 63	-----	-----
Worm Drive - Under 44 mm (1-3/4 in) Open Diameter	0.2 - 0.3	20 - 30	0.5 - 0.6	40 - 50
Worm Drive - Over 44 mm (1-3/4 in) Open Diameter	0.5 - 0.6	40 - 50	-----	-----
Worm Drive - All "Ultra-Tite"	0.6 - 0.7	50 - 60	0.5 - 0.6	40 - 50



## ORFS Swivel Nut Recommended Torque

Dash Size	Hose I.D.	Thread Size	Torque (kg.m) Recommended
4	1/4"	9/16"	2.4 - 2.6
6	3/8"	11/16"	3.3 - 3.9
8	1/2"	13/16"	5.1 - 5.7
12	3/4"	1 3/16"	11.7 - 12.7
16	1"	1 7/16"	15.3 - 17.3
20	1 1/4"	1 11/16"	18.0 - 20.0

## Torque Values for Split Flanges

The following chart provides the tightening torques for split flange connections used in hydraulic systems. Split flanges and shoulders should install squarely. Install all bolts, finger tight and then torque evenly.

**NOTE:** *Over torquing bolts will damage the flanges and/or bolts, which can cause leakage.*

Flange Size (*)	Bolt Size	Bolt Torque	
		Kilogram.meter (kg.m)	Foot-pounds (ft lb)
1/2"	5/16"	2.1 - 2.5	15 - 18
3/4"	3/8"	3.0 - 3.7	22 - 27
1"	3/8"	3.7 - 4.8	27 - 35
1 - 1/4"	7/16"	4.8 - 6.2	35 - 45
1 - 1/2"	1/2"	6.4 - 8.0	46 - 58
2"	1/2"	7.6 - 9.0	55 - 65
2 - 1/2"	1/2"	10.9 - 12.6	79 - 91
3"	5/8"	19.1 - 20.7	138 - 150
3 - 1/2"	5/8"	16.2 - 18.4	117 - 133

(\*) - Inside diameter of flange on end of hydraulic tube or hose fitting.

**NOTE:** *Values stated in chart are for Standard Pressure Series (Code 61) Split Flanges.*

# Torque Wrench Extension Tools

Very large diameter, high-grade fasteners (nuts, bolts, cap screws, etc.) require a great deal of turning force to achieve recommended tightening torque values.

Common problems that could occur as a result are:

- Recommended torque exceeds the measuring capacity of the torque wrench.
- Specialized sockets do not fit the adapter on the front end (nose) of the torque wrench.
- Generating adequate force on the back end (handle) of the wrench is difficult or impossible.
- Restricted access or an obstruction may make use of the torque wrench impossible.
- A unique application requires fabrication of an adapter or other special extension.

Most standard torque wrenches can be adapted to suit any one of the proceeding needs or situations, if the right extension tool is used or fabricated.

## Torque Multiplication

A wrench extension tool can be used to increase the tightening force on a high capacity nut or bolt.

For example, doubling the distance between the bolt and the back (handle) end of the torque wrench doubles the tightening force on the bolt. It also halves the indicated reading on the scale or dial of the torque wrench. To accurately adjust or convert indicated scale or dial readings, use the following formula:

$I = A \times T / A + B$  where:

I = Indicated force shown on the torque wrench scale or dial.

T = Tightening force applied to the nut or bolt (actual Torque).

A = Length of the torque wrench (between the center of the nut or bolt and the center of the handle).

B = Length of the extension.

As an example, if a 12" extension is added to a 12" torque wrench, and the indicated torque on the dial reads "150 ft lb", the real force applied to the bolt is 300 ft lb:

$I = \frac{A \times T}{A + B} = \frac{12 \times 300}{12 + 12} = \frac{3600}{24} = 150$
--

**NOTE:** *The formula assumes there is no added deflection or "give" in the joint between the extension and torque wrench. Readings may also be inaccurate:*

- If the extension itself absorbs some of the tightening force and starts to bend or bow out.

Figure 89

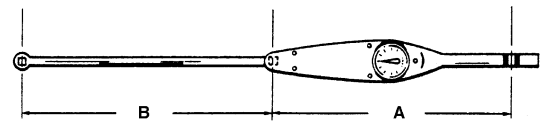

0552A

- If an extension has to be fabricated that is not perfectly straight (for example, an extension made to go around an obstruction, to allow access to a difficult to tighten fastener), the materials and methods used must be solid enough to transmit full tightening torque.

## Other Uses for Torque Wrench Extension Tools

Torque wrench extensions are sometimes made up for reasons other than increasing leverage on a fastener.

For example, a torque wrench and extension can be used to measure adjustment “tightness” of a linkage or assembly. Specially fabricated extensions can be used to make very precise checks of the force required to engage or disengage a clutch mechanism, release a spring-applied brake assembly, or “take up” free play in most any movable linkage.

Once the value of the adjustment force is established, repeated checks at regular intervals can help to monitor and maintain peak operating efficiency. These types of adjustment checks are especially useful if physical measurements of linkage travel are difficult to make or will not provide the needed degree of precision and accuracy.

To allow the assembly or mechanism to accept a torque wrench, welding a nut or other adapter on the end of a linkage shaft or other leverage point will allow turning the shaft or assembly manually.

## Tightening Torque Specifications (Metric)

(For coated threads, prelubricated assemblies.)

---

### NOTICE

Disassembly, overhaul and replacement of components on the machine, installation of new or replacement parts and/or other service-related maintenance may require the use of thread or flange sealing assembly compound.

Use the information on this page as a general guide in selecting specific formulas that will meet the particular requirements of individual assembly installations. HYUNDAI does not specifically approve a specific manufacturer or brand name, but the following table of “Loctite” applications is included for which cross-references to other manufacturer’s products should also be widely available.

---

### NOTICE

Use primer “T” or “N” for all cold weather assembly of fastener adhesives, with Thread locker sealers 222, 242/243, 262, 271, 272, or 277.

### I. "Loctite" Fastener Adhesives

Product	Application	Color	Removal	Breakaway Cure Strength (in lb) of Sealer Alone
222	Low strength for 6 mm (1/4") or smaller fasteners.	Purple	Hand tools	45
242 or 243	Medium strength for 6 mm (1/4") and larger fasteners.	Blue	Hand tools	80
262	High strength for high-grade fasteners subject to shock, stress and vibration.	Red	Heat/260°C (500°F) Remove HOT (NO solvent)	160
271	Extra high strength for fine thread fasteners up to 25 mm (1") diameter.	Red	Heat/260°C (500°F) Remove HOT	160
272	High temperature/high strength for hostile environments to 232°C (450°F).	Red	Heat/316°C (600°F) Remove HOT	180
277	Extra high strength for coarse thread fasteners 25 mm (1") diameter and larger.	Red	Heat/260°C (500°F) Remove HOT	210

### II. "Loctite" Pipe Thread Sealant

Product	Application	Color	Removal	Required Setup
545	"No filler/non clog" formula for high-pressure hydraulic systems. Over application will not restrict or foul system components.	Purple	Hand tools	4 Hours (or 1/2 hour with Locquic "T" Primer)
656	Solvent resistant, higher viscosity tapered thread sealer.	White	Hand tools	4 Hours (or 1/2 hour with Locquic "T" Primer)

### III. "Loctite" gasket/flange sealer

Product	Application	Color	Notes
518	Gasket eliminator specifically made for aluminum flanges/surfaces. For hydraulic systems to 34,475 kPa (5,000 psi).	Red	Use Locquic "N" primer for fast (1/2 - 4 hours) setup. Unprimed setup 4 - 24 hours.
504	Low-pressure/wide-gap gasket eliminator compound. Fills gaps to 0.762 mm (0.030"), cures to rigid seal.	Orange	Use Locquic "N" primer for faster (1/2 - 4 hours) setup. Unprimed setup 4 - 24 hours.
515	General purpose, fast setup, flexible-cure gasket eliminator. For nonrigid assemblies subject to shock, vibration or deflection.	Purple	Use Locquic "N" primer for faster (1/4 - 2 hours) setup. Unprimed setup 1 - 12 hours.

#### IV. "Loctite" retaining compounds

Product	Application	Color	Notes
609	For bushings, sleeves, press fit bearings, splines and collars. For gaps to 0.0002 mm (0.005"), temperatures to 121°C (250°F).	Green	Use Locquic "N" primer for increased bond strength and all cold temperature applications.
620	For high temperatures to 232°C (450°F).	Green	Same as 609, above.
680	For high strength bonds and tight clearance gaps, to 0.00008 mm (0.002").	Green	Same as 609, above.

#### V. "Loctite" Adhesives

Product	Application	Color	Notes
380	Black Max instant adhesive for shock and vibration-resistant bonds.	Black	May take 120 hours to reach full cure strength.
454	Adhesive for porous surfaces.	Clear	Full strength in 24 hours.
480	Increased strength (+50%), shock and vibration-resistant.	Black	Full strength in 24 hours.







# Engine

# Safety Instructions

---

## **WARNING**

---

### **AVOID DEATH OR SERIOUS INJURY**

Instructions are necessary before operating or servicing machine. Read and understand the Operation & Maintenance Manual and signs (decals) on machine. Follow warnings and instructions in the manuals when making repairs, adjustments or servicing. Check for correct function after adjustments repairs or service. Untrained operators and failure to follow instructions can cause death or serious injury.

Due to the high fuel pressure, leakage can cause jets of fuel that penetrates through the skin!

Always consider the high pressure part of the system (accumulator and high pressure lines) as pressurized. The pressure could be as high as 30,450 psi (2,100 bar). This applies also to an engine that is not running!

Before working on any of the fuel system components:

Depressurized the system with SDP3 and then loosen the cylinder high pressure line nut at the accumulator of the cylinder you are going to work on. Cover the nut with a cloth during the operation. Use safety glasses and gloves.

Avoid standing closer than 3 feet (1 m) to an engine at first start up after fuel system work has been conducted. Fuel jets will diverge within this distance from the source and become less harmful.

---

# Table of Contents

## Engine

Safety Instructions .....	140
General Information .....	142
General Description. . . . .	142
Engine Maintenance . . . . .	146
Inspection and Repair of the Engine . . . . .	148
Special Tools .....	150
Fuel System .....	155
General Information. . . . .	155
Injector. . . . .	156
Common Rail. . . . .	157
Injection Pipe. . . . .	162
Fuel Injection Pump. . . . .	162
Cooling System .....	164
General information. . . . .	164
Thermostat . . . . .	164
Cooling fan . . . . .	166
Exhaust System .....	168
Turbocharger. . . . .	168
Lubrication system .....	176
General Information. . . . .	176
Oil Pump . . . . .	178
Electrical System .....	179
Electric Parts . . . . .	179
Switches and Sensors. . . . .	180
ECU (Electronic Control Unit) . . . . .	181
Starter . . . . .	184
Alternator. . . . .	186
After Treatment System .....	188
Exhaust gas reduction system . . . . .	188

# General Information

## General Description

This manual provides the most efficient methods for engine maintenance as well as quick, efficient methods to determine the cause of engine faults to ensure that any actions taken by professionally certified maintenance technicians are done in the most efficient and efficient way possible. If maintenance is performed by unskilled technicians, or maintenance without the specified tools and facilities, serious bodily injury or critical faults in engine performance may occur. Regular inspection and maintenance are required to maintain long-term optimal engine conditions and best performance. In the event that a part must be replaced, only genuine parts as defined by the parts the list (Parts Book) should be used. HYUNDAI shall not be held liable for any critical damage or faults which may be caused by the use of unauthorized or remanufactured parts. The maintenance methods stated in this Operation and Maintenance Manual are the most efficient and safest work procedures. Some work procedures require special tools.

For questions about genuine parts and special tools, please contact us.

This manual includes 'Danger', 'Warning', and 'Caution' in order to reduce possible injuries and engine faults which may occur while performing maintenance. If workers do not follow the instructions, critical faults in engine performance and operation or serious bodily injury may occurred. 'Danger', 'Warning', and 'Caution' instructions must be followed. However, we inform you that it is not possible to describe all possible and unexpected dangers which may arise while performing engine maintenance.

### Cautions for Starting the Engine

1. Before starting the engine, please read this manual carefully and fully understand 'Danger', 'Warning', and 'Caution'. If you cannot fully understand it or have any question, please contact us.
2. For safety reasons, attach "Warning" signs around engines in operation to keep people other than workers from accessing the engines. Let engine operators know that they are responsible for the safety of the engine room.
3. Only authorized people may start and operate engines. Unauthorized people should not be allowed to handle engines.
4. Do not access running or rotating parts while the engine is in operation.
5. Be careful not to touch or contact the engine during operation since it becomes hot during operation.
6. Exhaust gas is poisonous. Fully ventilate before starting engine. If the space is airtight, ensure that it is well ventilated.

### Cautions for Inspection and Repair

1. Inspection and repair of engine should be performed only when the engine is stopped. Otherwise, burns or safety acci-

dents may occur, so do not perform inspection or repair while the engine is running.

2. If it is absolutely necessary to perform inspection or repair on the operating engine, do not get close to the rotating parts.

---

** DANGER**

---

**AVOID DEATH**

When accessories such as necklaces, rings, watches, or gloves become stuck in rotating parts while the engine is running, serious bodily injury may occur.

---

---

** WARNING**

---

**AVOID DEATH OR SERIOUS INJURY**

Do not exchange or disassemble a pipe or hose (from the engine fuel circuit, engine oil circuit, coolant circuit, or compressed air circuit) while the engine is running. The leaked liquid may cause bodily injuries.

---

3. Use an engine oil drain container that is large enough to prevent the overflow of engine oil while draining engine oil.
4. Open the engine coolant cap after fully cooling the engine to exchange or replenish coolant.

---

** WARNING**

---

**AVOID DEATH OR SERIOUS INJURY**

If the coolant cap is opened while the engine is still hot, hot water will spurt out and may cause burns. Open the engine coolant cap after fully cooling the engine.

---

5. Fuel is highly flammable. Smoking or use of fire around an engine may cause fire.

---

** WARNING**

---

**AVOID DEATH OR SERIOUS INJURY**

Only refuel when the engine is stopped.

---

6. Mark and separately manage the containers for storing coolant from beverage containers for avoiding confusion. See a doctor immediately in case of drinking coolant.
7. Follow the instructions provided by the battery manufacturer when checking or handling batteries.

---

## **WARNING**

---

### **AVOID DEATH OR SERIOUS INJURY**

Battery fluid is corrosive and dangerous because of its explosiveness and toxicity. Therefore, it should only be handled by a skilled technician who specializes in battery fluid.

---

8. Only certified professional technicians should repair and maintain engines.
9. Only appropriate tools should be used. If the jaws of a wrench are worn out, the wrench might slip during use, causing safety accidents.
10. Do not allow other persons to stay or pass under an engine when lifting the engine with a crane. Before lifting the engine, ensure that there is no one around the engine and reserve enough safety space.
11. Before inspecting or replacing the electrical apparatus, disconnect the battery ground wire first. Connect the battery ground wire after completing all required work for checking or replacing the electrical apparatus in order to prevent a short circuit.
12. Before performing electric welding works, turn off engine, block the power supply to the engine, and remove the wire harness connector connected to the engine control unit (ECU).
13. Do not give any electric or mechanical shocks or perform welding works on the electrical apparatus or the ECU.

### **General Repair**

1. Wait until the engine is properly cooled down before starting work, since you may get burned by the heated engine.  
Before performing fuel line work, check the common rail pressure and engine temperature by using the failure diagnosis device.
2. Disconnect the battery ground wire from to prevent damage of wires and sensors caused by a short circuit.
3. Engine oil and coolant may damage paint and should be stored in a separate container and marked for safe management.
4. Store the disassembled parts in a specified space to avoid damage or pollution.
5. Use specified and special tools for efficient and safe repair.
6. If parts need to be replaced, use only genuine parts for replacement. Using unauthorized or remanufactured parts may cause critical damage and faults in engine performance.
7. Replace parts such as cotter pins, gaskets, O-rings, seal rings, oil seals, and washers with new ones during repairs. Reuse of parts may be the cause of engine faults and engine may not operate properly.

8. Group and store disassembled parts in disassembling order. The strength, shape, and screw torque of bolts and nuts are different according to their assembly position. Please divide and store them accordingly to these characteristics.
9. Clean disassembled parts to remove foreign substances before inspecting or reassembling parts. Use compressed air to clean the oil holes or holes.
10. Thinly spread oil or grease on rotating parts or parts requiring lubrication, before assembling them.
11. If required, use a specified adhesive to assemble gaskets to prevent water or oil from leaking.
12. Assemble bolts and nuts with the specified tightening torque.
13. After completing repairs, conduct a final inspection and perform a test operation to check if all works have been successfully completed.

### **Other Safety Instructions and Environmental Pollution**

Observe the following instructions to protect workers from danger and to prevent the environmental pollution while performing engine repairs.

1. Good ventilation and low humidity should be maintained in the work space.
2. The workspace should be clean, in good order, and no flammables are allowed in the workshop.
3. Smoking is strictly forbidden in the workshop.
4. Workers should wear working clothes, protective goggles, and safety shoes.
5. Workers are not allowed to wear accessories such as necklaces, rings, watches, and earrings.
6. Start the engine in a well-ventilated space and fully ventilate the space before starting engine to prevent carbon monoxide poisoning.
7. Wait until the engine is properly cooled down before starting work, since you may get burned by the heated engine.
8. Do Not work on rotating or running parts once the engine has been started.
9. Discard oil according to the regulations set forth by the relevant authorities.
10. If engine oil or fuel leaks on the floor or is improperly discharged, serious environmental pollution of sea, river or underground water may occur.
11. Discard the undiluted anticorrosive agent, antifreeze, filter elements, and cartridges as special wastes.
12. Discard coolant and special waste according to the regulations of the appropriate authorities.

---

## **WARNING**

---

### **AVOID DEATH OR SERIOUS INJURY**

Failure to observe the regulations of the relevant authorities violates environmental pollution regulations and may be subject to legal penalties.

---

### **Use of Genuine Parts**

An engine consists of many parts which are mechanically harmonized. To prevent engine faults in advance and use engines with best performance for a long period, maintenance and replacement of expendable parts should be conducted regularly.

Use of genuine parts is recommended. Using unauthorized or remanufactured parts may cause critical damage and faults to engine for which Hyundai shall not be held liable.

## **Engine Maintenance**

### **Prevention of Damage and Abrasion**

Using an engine for any purposes other than the designed purpose may cause critical faults in engine performance for which Hyundai shall not be held liable. For details concerning the usage and purpose of the engine, please direct questions to our Sales Team. Do not adjust, convert, or change the ECU without our authorization.

If a problem is found in an engine, figure out and solve the cause to prevent the critical faults in advance. Use of genuine parts is recommended. Using unauthorized or remanufactured parts may cause critical damage and faults to engine for which Hyundai shall not be held liable.

Consider the following while managing engines.

1. Use clean, specified, and qualified fuel only. Use fuel recommended in this Operation and Maintenance Manual.

---

## **CAUTION**

---

### **AVOID INJURY**

Using inappropriate or unspecified fuel may cause critical damage and faults in engine performance.

---

2. Do not operate an engine without lubrication oil or coolant. Use only the products (engine oil, cooling water, anticorrosive agent, and etc) recommended by Hyundai.
3. Always keep surroundings of the engine clean.
4. Use fuel recommended in this Operation and Maintenance manual.
5. Conduct inspections and exchanges regularly according to the regular inspection table.



6. If the engine is overheated, do not stop it immediately, but operate it at idle status for five minutes or more to lower the engine temperature to the proper level.

---

** WARNING**

---

**AVOID DEATH OR SERIOUS INJURY**

If the radiator cap is opened while the engine is still hot, hot water will spurt out and may cause burns.

---

7. Check the engine oil level on a flat surface. Do not exceed the maximum on the oil level gauge.

---

** CAUTION**

---

**AVOID INJURY**

Immediately replenish engine oil when the engine oil level is below the lower limit of the engine oil gauge.

---

8. If there are gauges for battery, oil pressure and coolant and temperature, check if they indicate a normal status.
9. Do not operate engine without coolant.

---

** CAUTION**

---

**AVOID INJURY**

Always use coolant mixed with antifreeze. If coolant without antifreeze is used, the coolant may freeze causing the coolant passage in the cylinder block to freeze and damaging the engine.

---

### **Prevention of Pollution**

Consider the following to manage engine without causing environmental pollution.

1. Discharge oil and coolant using collection containers.
2. Discard oil and coolant according to the regulations of the relevant authorities.
3. Be careful not to let discharged oil and cooling water flow into the ground or the sewer. Otherwise, serious pollution of the drinking water source may occur.
4. Classify the oil, filters, and filter cartridges as environmental pollution wastes and discards them according to regulations.
5. Classify the antifreeze, cooling water, and anticorrosive agent as hazardous wastes and discards them according to the regulations.

## Handling of Engine Oil

Prolonged and repeated contact of skin with engine oil may cause skin to dry out and contract, causing dermatitis. Engine oil includes substances toxic to the human body. Handle engine oil by observing the following safety rules:

1. Do not expose skin to new engine oil for a long time.
2. Always wear working clothes and gloves.
3. If skin comes in contact with engine oil, immediately wipe it off with water, soap or hand cleaners.
4. Do not clean skin with gasoline, fuel, thinner, or solvent.
5. Apply a skin protective cream after cleaning from oil.
6. Do not put oil-stained gloves or cloth in ones pocket.

---

### **WARNING**

---

#### **AVOID DEATH OR SERIOUS INJURY**

Discard oil according to the regulations set forth by the relevant authorities. Disposing of discharged oil into the ground, sewers, drains, rivers, or the sea will cause serious environmental pollution. Violation of regulations regarding discard of engine oil without observing the handling regulations, will be punished.

---

## Inspection and Repair of the Engine

### Checking Engine Parts after Prolonged Operation

Wear, corrosion, or degradation of engine elements and assemblies may occur, causing lowered performance of engine parts. To maintain high engine performance, check the engine after prolonged operation to enhance the durability of the engine.

Unexpected faults may occur in some weak engine parts after normal operation of the engine, when operation time is prolonged. In this case, it is difficult to maintain high engine performance by simply repairing some parts. We recommend the entire part be replaced or repaired in order to find out the causes more accurately and maintain high engine performance.

To prevent engine failure in advance and use the engine safely for a long period, perform periodic replacements and inspections.

It is recommended to perform engine adjustments and preventive inspections during spring after the engine was exposed to winter or cold weather. This allows economic, long-term use of the engine without faults. As the following parts affect the engine output and performance, these parts should be regularly checked and inspected.

1. Parts affecting intake and exhaust
  - Air filter
  - Intercooler

- Turbocharger, muffler
- Other parts

## 2. Parts affecting lubrication and cooling

- Air filter
- Oil filter
- Antifreeze
- Other parts

### **Inspection and Repair of Turbocharger**

As performance of supercharger significantly affects the engine performance, regular inspections and repairs should be performed and inspection and maintenance regulations should be observed.

#### **Intake Unit**

Be careful when handling the air filter in the intake unit. If oil level of the wet air filter is below the specified level, filtering performance is degraded. On the other hand, if the oil level is higher, oil may flow into the case, and it may become polluted. In regards to the dry air filter, intake resistance should be small to ensure the smooth intake of air.

#### **Exhaust Unit**

If exhaust emission is leaked from the part connecting the exhaust tube and the turbocharger, the supercharger efficiency is lowered, causing degraded engine output and, if serious, burning of related parts. As parts related to exhaust and turbocharger are used at high temperature, be careful not to mix the bolts and nuts with other parts when performing repair.

#### **Lubrication System**

Inspection and replacement of the lubrication system should be performed according to the replacement schedule of oil and oil filter. Overheated engine oil can affect not only the engine itself, but also the engine performance.

# Special Tools

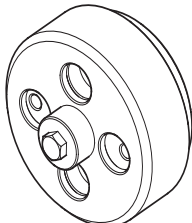
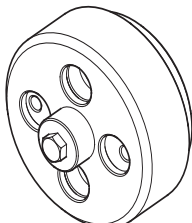
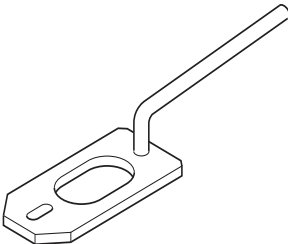
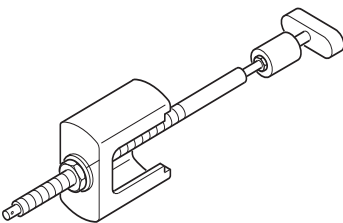
Number	Designation	Picture	Tool Board
EF.121-299	Oil Seal Installation Jig(Front)	 <p>EX1403581</p>	
EF.121-300	Oil Seal Installation Jig(Rear)	 <p>EX1403581</p>	
EF.123-065	Valve Spring Compressor	 <p>EX1403582</p>	
EF.123-365A	Cylinder Liner Disassembly Tool	 <p>EX1403583</p>	

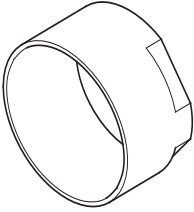
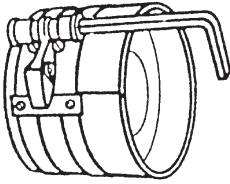
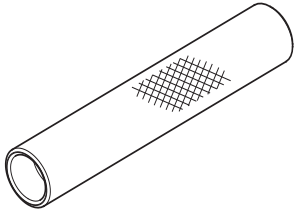
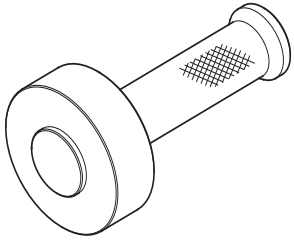
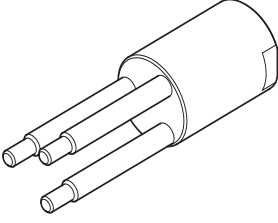
Number	Designation	Picture	Tool Board
EF.121-250	Piston Inserting Tool (Only for DL06 Engine)	 <p data-bbox="1150 478 1241 499">EX1403584</p>	
EF.120-208	Piston Inserting Tool(for all Engine Models)	 <p data-bbox="1150 825 1241 846">EX1403585</p>	
EF.121-253	Valve Stem Seal Inserting Tool(for all Engine Models)	 <p data-bbox="1150 1171 1241 1192">EX1403586</p>	
EF.121-181	Camshaft Hole Cover Punch	 <p data-bbox="1150 1528 1241 1549">EX1403587</p>	
EF.121-252	Step Idle Gear Pin Installation Jig	 <p data-bbox="1150 1875 1241 1896">EX1403588</p>	

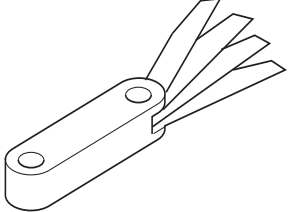
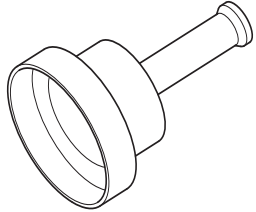
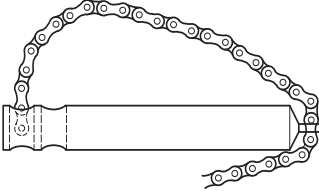
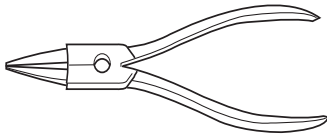
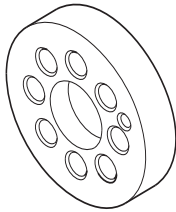
Number	Designation	Picture	Tool Board
60.99901-0027	Feeler Gauge	 <p data-bbox="1061 478 1157 506">EX1403589</p>	
EF.121-260	Wear Ring Punch (Rear)	 <p data-bbox="1061 829 1157 856">EX1403590</p>	
65.98801-0001	Filter Wrench	 <p data-bbox="1061 1176 1157 1203">EX1403591</p>	
T7610001E	Snap Ring Pliers	 <p data-bbox="1061 1522 1157 1549">EX1403592</p>	
EF.121-259	Crankshaft Gear Inserting Jig	 <p data-bbox="1061 1869 1157 1896">EX1403593</p>	

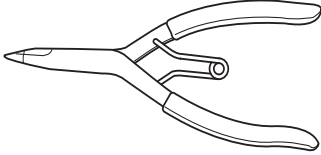
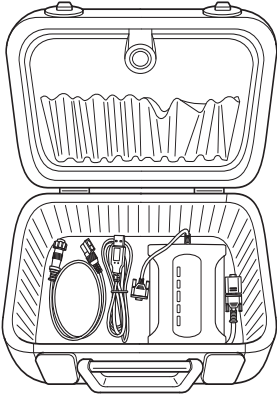
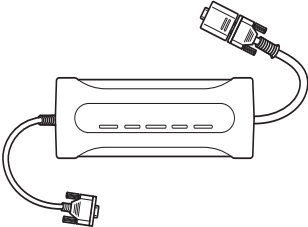
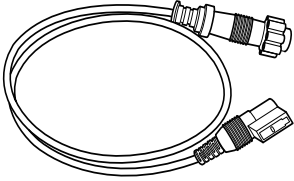
Number	Designation	Picture	Tool Board
T7621010E	Piston Ring Pliers	 <p data-bbox="1150 478 1241 499">EX1403732</p>	
860104-01045	Diagnostic Device	 <p data-bbox="1150 978 1241 999">EX1403595</p>	
860104-01046	UVIM (CAN Module)(for Diagnostic Device)	 <p data-bbox="1150 1325 1241 1346">EX1403597</p>	
860104-01047	14-pin Connector(for Diagnostic Device)	 <p data-bbox="1150 1675 1241 1696">EX1403596</p>	

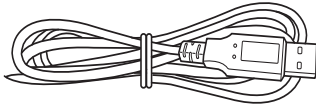
Number	Designation	Picture	Tool Board
860104-01048	USB(for Diagnostic Device)	 <p data-bbox="1061 478 1155 499">EX1403598</p>	



# Fuel System

## General Information

Diesel engines compress air drawn into the cylinders, creating compression heat, then when fuel is injected through the injection nozzles, combustion arises due to the compression heat. The high-pressure fuel created by the high-pressure fuel pump is stored in the common rail, and the injection timing and injection amount are determined by the electronic control unit (ECU). The electronic control unit activates the solenoid valve on the injectors installed in each cylinder and causes them to inject fuel. Doosan's common rail fuel injection system is divided into a pressurizing device and a fuel injection device. In order to provide optimal performance based on the engine operating conditions, fuel is injected into the cylinders after the amount of fuel, injection timing and injection pressure are determined by the electronic control unit. The common rail fuel injection system is composed of a low-pressure stage for the low-pressure delivery of fuel, a high-pressure stage for high-pressure delivery, and an electronic control unit. The fuel tank must be made of a non-corrosive material and there must be no leaks at twice the operating pressure of the low-pressure fuel pump. The pressure inside the tank must not exceed 0.3 bar.

Figure 90

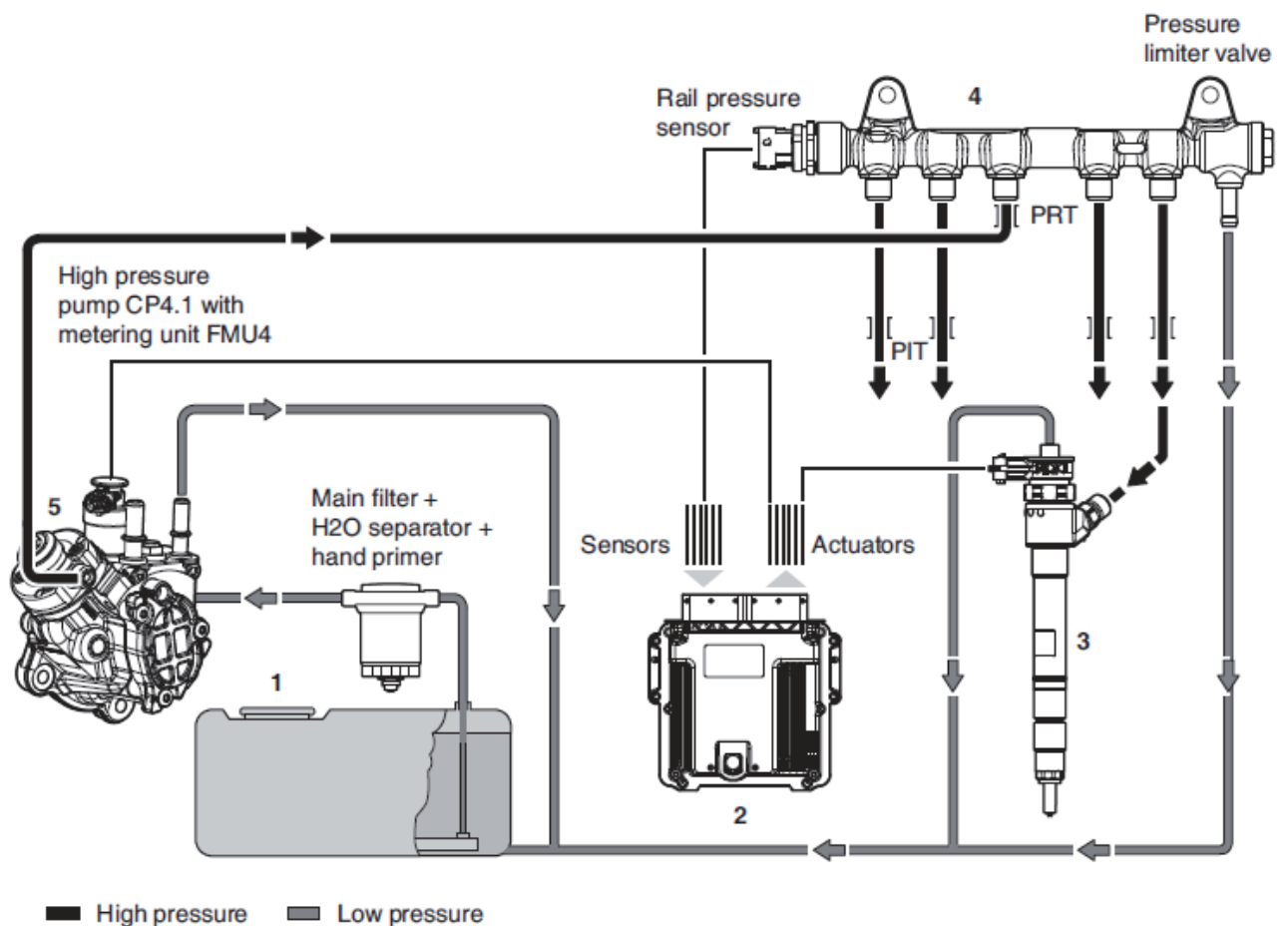

DS2103716

1	Tank with prefilter	4	Common rail
2	Electronic Control Unit (ECU)	5	Fuel injector pump
3	Injector		

## Injector

In the nozzle of the injector, a solenoid valve activates to enable fuel to flow, then the injector injects fuel directly into the combustion chamber of the engine. When the injector nozzle opens, the required fuel is delivered and the remaining fuel returns to the tank via the return line. In addition, the fuel returned from the fuel pressure adjustment valve and low-pressure stage, and the fuel used to lubricate the high-pressure pump return to the fuel tank together via the return line. The start of fuel injection and the amount of injection area adjusted by the solenoid valve installed in the injector. The injector replaces the function of the nozzle and nozzle holder in previous engines. Fuel is delivered to the injector through the high-pressure connector installed in the cylinder head, and then delivered to the valve control chamber through the delivery hole. The valve control chamber is opened by the solenoid valve, passes through the discharge hole and then connected to the fuel return line. The force of the hydraulic pressure applied to the valve control plunger while the discharge hole is closed exceeds the pressure value of the nozzle needle. As a result, the fuel supply to the combustion chamber is shutoff by the force applied to the contact surface of the nozzle needle. When the solenoid valve of the injector is pulled, the discharge hole is opened. This lowers the pressure in the control chamber and the force of the hydraulic pressure acting on the plunger also drops. If the force of the hydraulic pressure drops below the force acting on the nozzle needle pressure, the nozzle needle opens. Then fuel is injected into the combustion chamber via the injection nozzle hole. This is because in controlling the nozzle needle using the force of hydraulic pressure, the force needed to open the valve quickly is not generated directly by the solenoid valve. The fuel control amount required for opening the nozzle needle is added to the amount of fuel actually injected. And the used fuel is discharged to the fuel return line through the hole in the valve control chamber. Fuel loss occurs not only in the control but also in the nozzle needle and valve plunger guide. The control leakage fuel and the fuel gathered from the line which connects the overflow valve, the high-pressure pump, and the pressure control valve, is returned to the fuel tank through the fuel return line.

### Injector Operating Principles

The operation of the injector is divided into four actions of engine operation and the high-pressure pump which generates pressure. These operating stages are determined by the distribution of the force acting on the components of the injector, and if the engine is stopped or there is no pressure on the common rail, the injector nozzle does not work.

1. Injector closed (resting) During the resting state where no power is provided to the solenoid valve of the injector, the injector does not operate. The valve ball is pressed against the discharge hole seat surface of the injector by the force of the valve spring and a magnetic force. The high pres-

sure within the common rail is maintained by the fuel control valve and formed in the nozzle chamber of the injector by the same pressure. The common rail fuel pressure acting on the end of the valve control chamber in the injector and the force acting on the nozzle spring in the injector are greater than the force of the nozzle attempting to open, so the closed state is maintained.

2. Injector open (fuel injection begins) When power is supplied while the injector solenoid valve is closed, the fuel discharge hole is opened by the pulling force of the solenoid valve. At this time, the high current applied to the solenoid almost simultaneously decreases to a low current. This is possible because the air gap in the electromagnetic circuit decreased. The fuel in the valve control chamber flows through the discharge valve hole, and from there, it passes through the fuel return line into the fuel tank. The discharge hole completely disrupts the pressure balance and drops the pressure in the valve control chamber. This further drops the chamber pressure in the nozzle which is at the same pressure as the common rail and the pressure in the valve control chamber. This pressure reduced in the valve control chamber causes a decrease in the force acting on the control plunger and as a result, the nozzle needle opens and fuel injection begins.

3. Injector fully open (fuel injection) The valve control plunger stops in the upper position due to the fuel buffer created when fuel flows between the discharge and delivery hole. At this time, the injector nozzle opens completely and fuel is injected into the combustion chamber at the same pressure as the common rail.

4. Injector closed (end of injection) When the power supply to the injector solenoid valve is shut off, the valve spring immediately applies a downward force to the armature and the valve ball closes the discharge hole. The armature is composed of two parts. The armature plate is guided by the driving shoulder and pressed downward. However, an over spring with a return spring is used so that the force acting on the armature and valve ball is not applied downwards. The closing of the discharge hole causes fuel to enter from the delivery hole and form pressure in the control chamber. This fuel pressure, identical to the pressure in the common rail, applies pressure to the valve control plunger through the end of the valve control plunger. This and the force of the spring exceed the pressure formed in the nozzle chamber and close the nozzle needle. The closing speed of the nozzle needle is determined by the flow rate passing through the delivery hole, and as soon as the nozzle needle reaches the stop position, fuel injection is shut off.

1. Injector closed (fuel is pressurized)
2. Injector open (fuel injection begins)
3. Injector fully open (fuel injection)
4. Injector closed (end of fuel injection)

## **Common Rail**

### **General Description**

Doosan's common rail fuel injection system is divided into a pressurizing device and a fuel injection device. In order to provide optimal performance based on the engine operating conditions,

fuel is injected into the cylinders after the amount of fuel, injection timing and injection pressure are determined by the electronic control unit. The high-pressure fuel created by the high-pressure fuel pump is stored in the common rail, and when the driver operates the machinery, the optimal amount of fuel and fuel injection timing are determined based on the data set in the electronic control unit (ECU) according to the vehicle speed and driving conditions. The solenoid valves in the injectors installed on each engine cylinder are then activated and the fuel is injected into the cylinders.

**Figure 91**

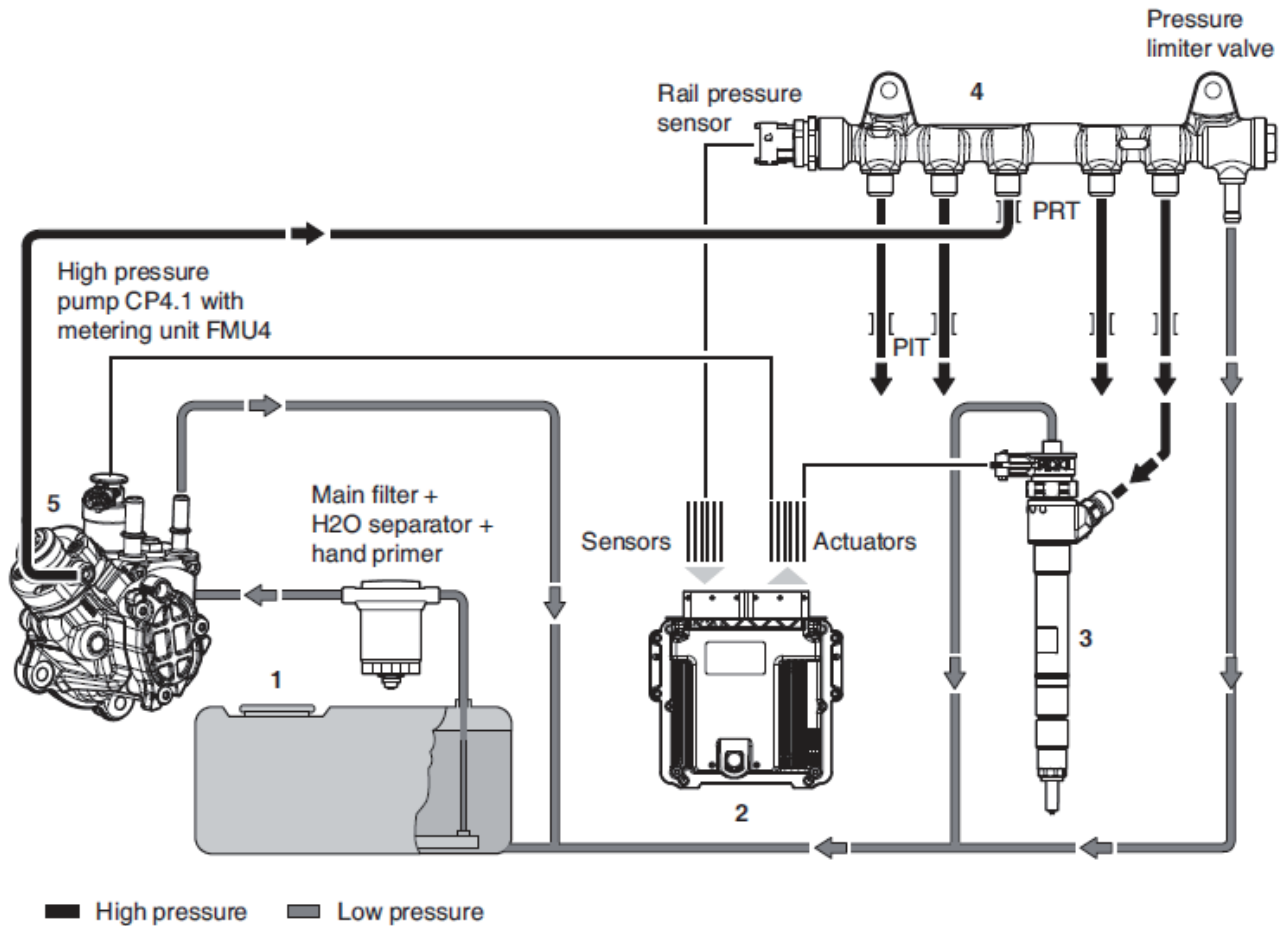

DS2103716

1	Tank with pre-filter	4	Common rail
2	Electronic Control Unit (ECU)	5	Fuel injector pump
3	Injector		

The main components of the common rail fuel injection system are as follows.

1. Electronic control unit (ECU)

- The electronic control unit (ECU) receives an input signal from the sensor above based on the operator's accelerator reaction and momentarily adjusts the engine and vehicle to the operating performance. The electronic control unit also

uses this information to activate the open/ close circuit and circulation circuit of the vehicle and engine.

- The engine speed is measured by the crankshaft rpm sensor, and the camshaft rpm sensor is used to determine the firing order. The electrical signal created in the potentiometer of the accelerator pedal sensor lets the electronic control unit know how far down the operator has pushed the pedal. In addition, there are turbocharger and intake pressure sensors installed. The intake pressure sensor measures the intake pressure.
- In cold outside weather and when the engine is cold, the electronic control unit receives data from the coolant temperature sensor and air temperature sensor and enables the vehicle to run under conditions suitable to the engine operation.

## 2. Crankshaft RPM sensor

- The positions of pistons in the combustion chamber play a very important role in injecting fuel. All engine pistons are connected to the crankshaft by means of connecting rods. The crankshaft rpm sensor installed in the flywheel housing provides information about the position of every piston. The rotation speed is defined as the number of rotations of the crankshaft per minute, and the main input variables are calculated by the electronic control unit (ECU) using signals from the crankshaft rpm sensor.

## 3. Camshaft RPM Sensor

- The camshaft rpm sensor controls the engine intake and exhaust valves. This rotates at half the speed of the crankshaft and determines whether the camshaft position is in the compression stage or the exhaust stage when the piston moves in the TDC direction. This information cannot be detected by the crankshaft rpm sensor. On the other hand, while the engine is running normally, the data generated by the crankshaft ramp sensor is sufficient for defining the state of the engine. This means that the electronic control unit receives the state of the engine from the crankshaft rpm sensor if the camshaft rpm sensor is not responding while the vehicle is in operation.

## 4. Accelerator Pedal Sensor

- The accelerator pedal sensor delivers the data generated when the operator steps on the accelerator to the electronic control unit (ECU). The voltage value is created by the potentiometer in the accelerator pedal sensor, and the programmed characteristic curve is used to calculate the position of the pedal.

## 5. Fuel Temperature Sensor

- A sensor that measures the fuel temperature in the fuel pump.

## 6. Boost Pressure and Temperature Sensor

- The boost pressure and temperature sensor is connected to the intake manifold with an O-ring and measures the absolute pressure and temperature inside the intake manifold. The output signal is inputted in the electronic control unit, and here, the boost pressure is calculated based on the programmed characteristic curve.

## 7. Oil Pressure Sensor

- The engine oil pressure sensor detects the pressure and temperature and conveys them to the electronic control unit (ECU).

## 8. Common Rail Pressure Sensor

- A sensor installed on the end of the common rail which measures the instantaneous internal pressure in the common rail.

## 9. Engine Coolant Temperature Sensor

- The engine coolant temperature sensor detects the temperature of the engine coolant and conveys it to the electronic control unit (ECU).

**Figure 92**

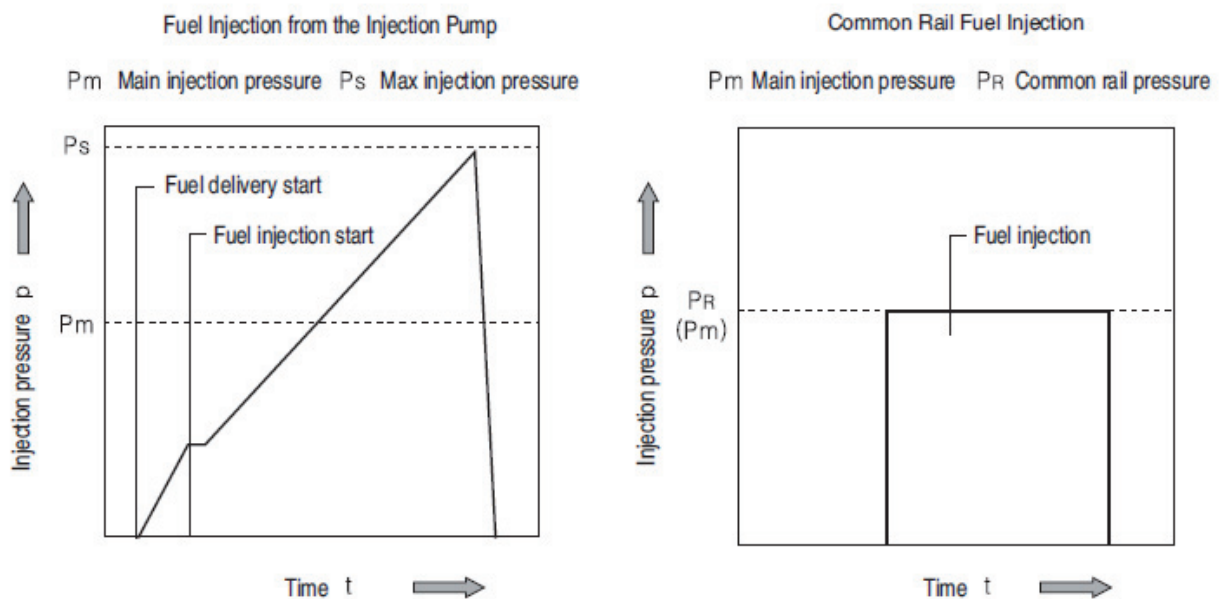

DS2103717

The injection characteristics of the common rail are as follows.

1. Common rail fuel injection requires the following ideal fuel injection in comparison with previous injection characteris-

tics. The common rail fuel injection amount and injection pressure operate independently of one another and satisfy all engine conditions.

2. At the start of the fuel injection process, the amount of injection during the ignition delay time between the start of fuel injection and the start of combustion needs to be adjustable to a low level.
3. The common rail system is a modular system and the following components play a fundamentally important role in the injection characteristics.
  - Injector solenoid valve installed on the cylinder head
  - Common Rail
  - High-pressure fuel pump
  - Electronic control unit (ECU)
  - Crankshaft RPM sensor

### **Pressure Limit Valve & Rail Pressure Sensor**

Before working on the common rail high pressure fuel system, a minimum waiting time of 30second after engine shut-down is mandatory. Any work at the common rail high pressure fuel system (rail, function-block, pressure control valve, pressure limiting valve, rail pressure sensor, pipe connection, high pressure pipes (pump/rail or /function block, function block/rail, rail/injectors)) is not permitted when the engine is running.

---

## **CAUTION**

- 
- Cutting fuel jets: injury-risk at eyes and skin.
  - When opening the high pressure fuel system, fuel jets can ignite on hot engine surfaces.
- 

The first high pressure component has to loosened slowly, so that the pressure inside the fuel system can adjust to ambient pressure.

## Pressure Limit Valve (PLV)

Figure 93

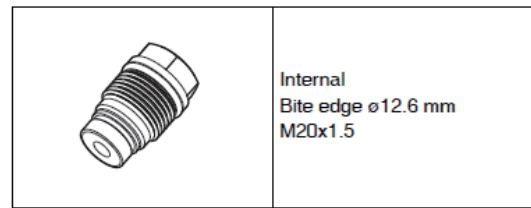

DS2103718

## Rail Pressure Sensor (RPS)

Figure 94

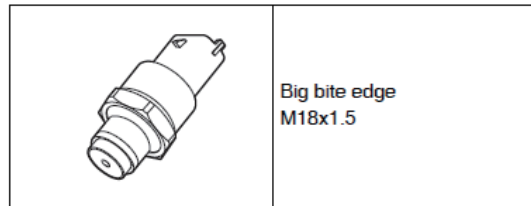

DS2103719

## Injection Pipe

### High-pressure fuel pipe

The high-pressure fuel pipe delivers 1,800 bar high-pressure fuel. Hence, the pipe of the fuel line is made of a special material which is able to withstand even the maximum pressure of the system and the fluctuations in high pressure arising during fuel injection. The high-pressure pipe has an outside diameter of  $\varnothing 6.35$  and an inside diameter of  $\varnothing 3.0$ . In addition, the length of the high-pressure fuel pipes installed between the common rail and injectors must be identical and as short as possible.

### Common Rail

1	Fuel Injection pump	5	Fuel injection pipe (Fuel injection pump - Common rail)
2	Injector	6	Fuel injection pipe(Common rail - Injector)
3	Common rail	7	Fuel return hose (Common rail - Fuel injection pump)
4	Pressure sensor	8	Fuel return hose (Injector - Fuel injection pump)

Figure 95

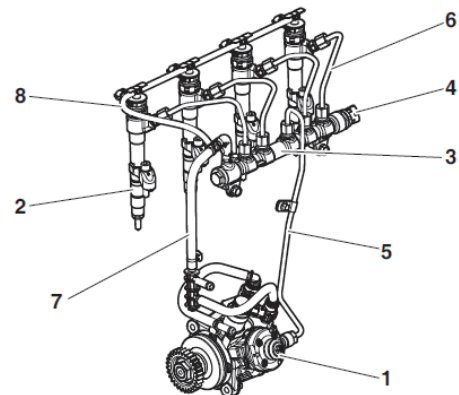

DS2103720

## Fuel Injection Pump

The high pressure in the high-pressure fuel pump is generated using a radial piston pump. The pressure is generated independently in the fuel injection process. The rpm of the high-pressure fuel pump is related directly to the engine rpm, regardless of the transmission speed. In comparison with previous injection



systems, the amount of fuel delivery in the common rail injection system is consistent. The injector is connected to the common rail with a high-pressure pipe and is composed of a nozzle and solenoid valve. When the key switch is activated, operating power is supplied to the solenoid valve by the electronic control unit. When the key switch is turned off, the solenoid valve ceases injection.

The solenoid valve switch (ON/ OFF) on the injector is activated by high voltage and current. This causes the injector solenoid valve to operate sequentially based on the value set in the electronic control unit. The crankshaft sensor and camshaft sensor are used to detect the engine rpm for adjusting the start of fuel injection and injection timing. The high-pressure fuel pump pressurizes fuel to a pressure of around 1,800 bar, and this pressurized fuel is sent through the high-pressure line to the pipe-shaped common rail.

**Figure 96**

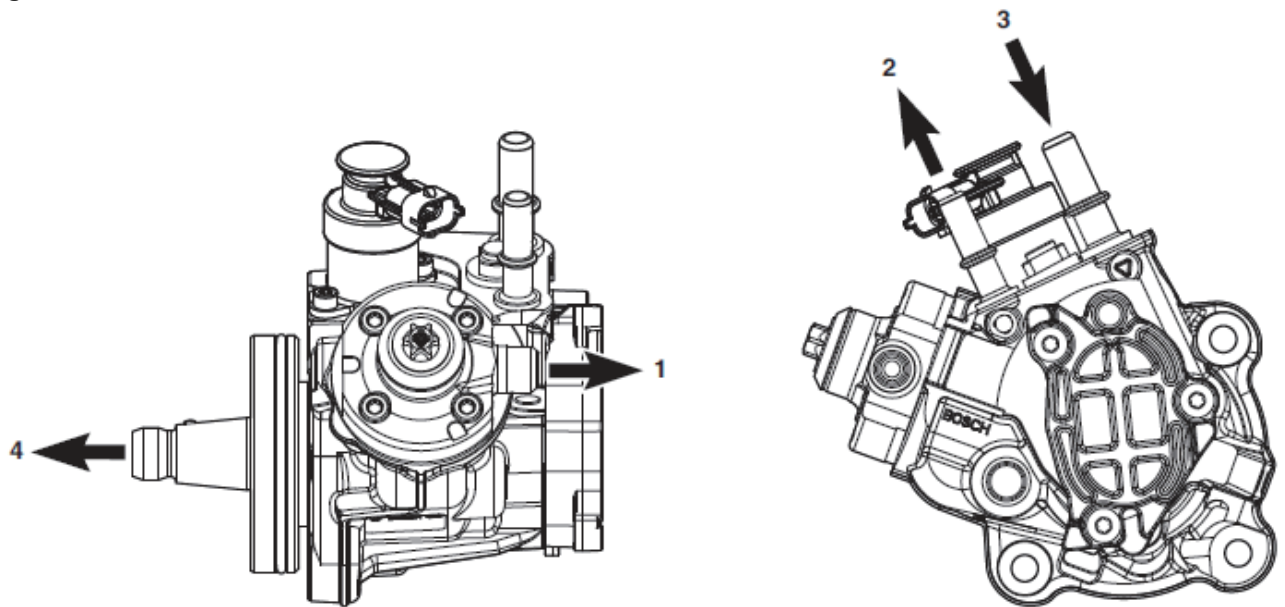

DS2103721

1	High pressure fuel line outlet	3	Low pressure fuel line inlet
2	Low pressure fuel line outlet	4	Drive shaft

# Cooling System

## General information

### General Description

This engine is a water-cooled type. Combustion heat from the combustion chamber and heat from engine oil are absorbed by coolant and dissipating them to the outside air to ensure optimum engine operation.

In the cooling system, coolant supplied from the coolant pump is sent to the oil cooler through the coolant pipe to absorb heat from oil before it passes through the coolant jacket of the cylinder block and through the cooling passage of the cylinder head to absorb combustion heat.

After this coolant absorbs oil heat and combustion heat, it is led to the thermostat through the coolant pipe. If the coolant temperature is below the valve opening temperature of the thermostat, the coolant flows into the coolant pump. If the temperature is over the opening temperature, it flows into the radiator. In the radiator, it releases heat and returns back to the coolant pump in a low temperature condition again.

**Figure 97**

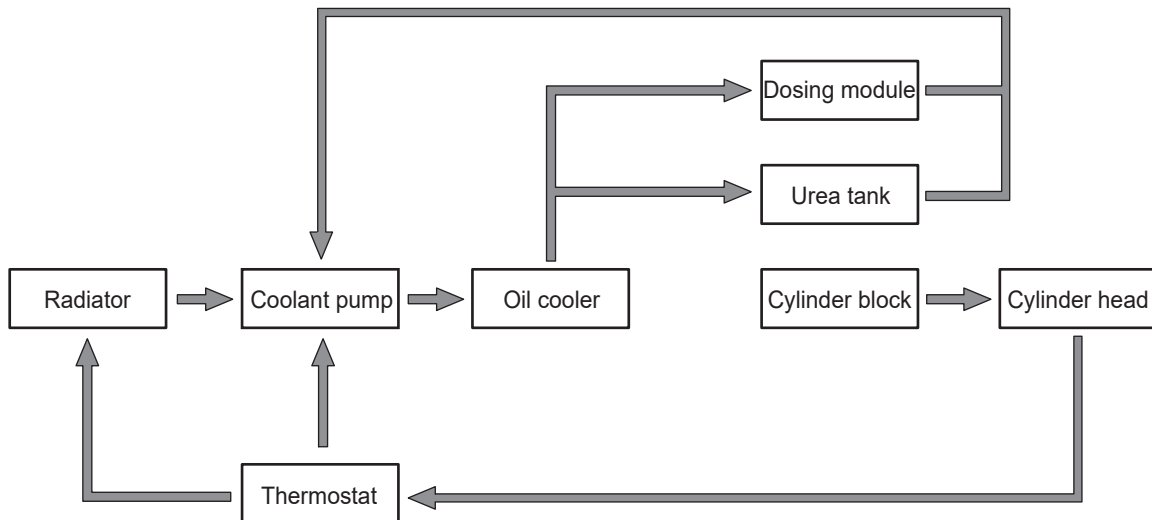

DS1901799

## Thermostat

### General Description

The thermostat maintains water temperature in the engine consistently and prevents heat loss to improve heat efficiency of the engine.

When the coolant temperature is below the normal temperature, the thermostat is closed and the coolant is bypassed and directly flows into the water pump. When the coolant temperature reaches the normal temperature or is higher than the temperature, the thermostat is fully open and the bypass circuit is closed. So the coolant flows into the radiator.

---

**⚠ CAUTION**

---

**AVOID INJURY**

- The wax pellet type thermostat shows slower response to the change of cooling water than the bellows type thermostat. This happens because the heat capacity of the wax pellet type thermostat is larger than that of the bellows type thermostat. Therefore, to prevent a rapid increase in the engine coolant's temperature, you must first operate the engine at idle until the engine is fully warmed up. When the weather is very cold, do not operate the engine in an overloaded condition or at a high speed after starting the engine.
- When draining water from the engine cooler or injecting water to the engine cooler, work slowly to ensure that all air inside the cooler is expelled.
- When a defect is found in the thermostat, replace it with a new one.

---

Reference Number	Description
1	Heat Exchanger
2	Bypass Valve
3	Water Pump
4	Coolant Pipe

**Cautions for Replacement and Handling of Thermostat**

**1. Cautions for handling**

A wax pellet type thermostat features relatively slow response for change in coolant temperature compared to a bellows type. This is because the wax pellet type has larger thermal capacity. Therefore, it needs to idle the engine sufficiently before running it in order to prevent surge of engine coolant temperature. In cold weather, never overload the engine or speed drive.

**2. When adding or draining coolant to/from the engine cooling system, do it slowly to let air in the system escape.**

**3. Thermostat replacement**

If any defect is found on the thermostat, replace it with a new one.

**Figure 98**

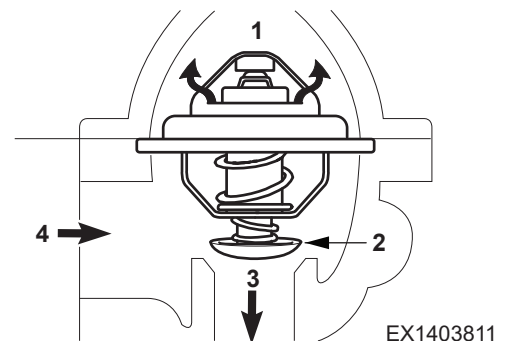

## Thermostat inspection

1. Check if the wax pellet and spring are damaged.
2. Put the thermostat into water and heat the water gradually to check for operation of the thermostat.

If the thermostat starts to open at 83°C (water temperature) and it is fully open at 95°C, it is normal.

3. Check if there is any foreign material in the thermostat.

**NOTE:** Clean the inside of the thermostat using a air gun.

4. Check the hose for internal or external damage or foreign materials.

Figure 99

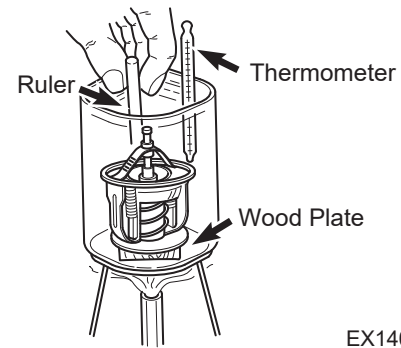

EX1403812

## Cooling fan

### General Description

The speed of the cooling fan is controlled by the electronic fan clutch in order to maintain its optimum speed. The electronic fan clutch adjusts the cooling fan speed electrically according to the coolant temperature, hydraulic oil temperature, CAC (Charge Air Cooler) temperature and engine speed to reduce cooling fan noise and obtain superior efficiency.

### Troubleshooting

Phenomenon	Causes	Troubleshooting
Overheated Engine	Not enough coolant	Replenish the coolant
	Defective radiator cap	Replace it
	Contaminated radiator	Clean the exterior of the radiator
	Defective V-belt offset	Adjust or replace it
	Contaminated or damaged V-belt	Replace it
	Damaged impeller	Replace the water pump
	Defective impeller fix	Replace the water pump
	Bad water pump operation	Replace it
	Bad thermostat operation	Replace it
	Bad coolant flow	Clean the coolant path
	Improper injection time	Check it with the failure diagnosis unit
	Damaged cylinder head gasket	Replace it
Overcooled Engine	Bad thermostat operation	Replace it
	Too low ambient temperature	Heat the block

<b>Phenomenon</b>	<b>Causes</b>	<b>Troubleshooting</b>
Leaking Coolant	Damaged radiator	Repair or replace it
	Loosened or damaged radiator connection	Repair or replace the connection
	Defective radiator cap	Replace it
	Badly mounted water pump	Repair or replace it
	Bad or damaged water pump gasket	Replace the gasket
	Badly mounted thermostat	Repair or replace it
	Bad or damaged thermostat gasket	Replace the gasket
	Damaged cylinder head gasket	Replace the gasket
	Damaged cylinder head or block	Replace it
Noise	Bad water pump bearing	Replace the bearing
	Bad or damaged cooling fan	Repair or replace it
	Bad rotation of the cooling fan	Replace it
	Defective V-belt offset	Adjust or replace it

# Exhaust System

## Turbocharger

### General Description

The turbocharger uses heat energy of exhaust gas in the engine to draw in high density air into the cylinders to increase the engine power.

Power of the engine is determined by the amount of fuel supply and the engine's efficiency.

A sufficient amount of air should be supplied to the cylinders to burn fuel completely and convert this energy to effective work.

Power of the engine is actually determined by the size of the cylinders. The larger the cylinders are, the more the air is delivered to burn more fuel, resulting in increase of engine power.

Supercharging is a process to compress and supply air into the engine's cylinders. The turbocharger is a device to supply extra air for combustion with energy of exhaust gas in the combustion chamber which is usually released and disappeared into the air.

**Figure 100**

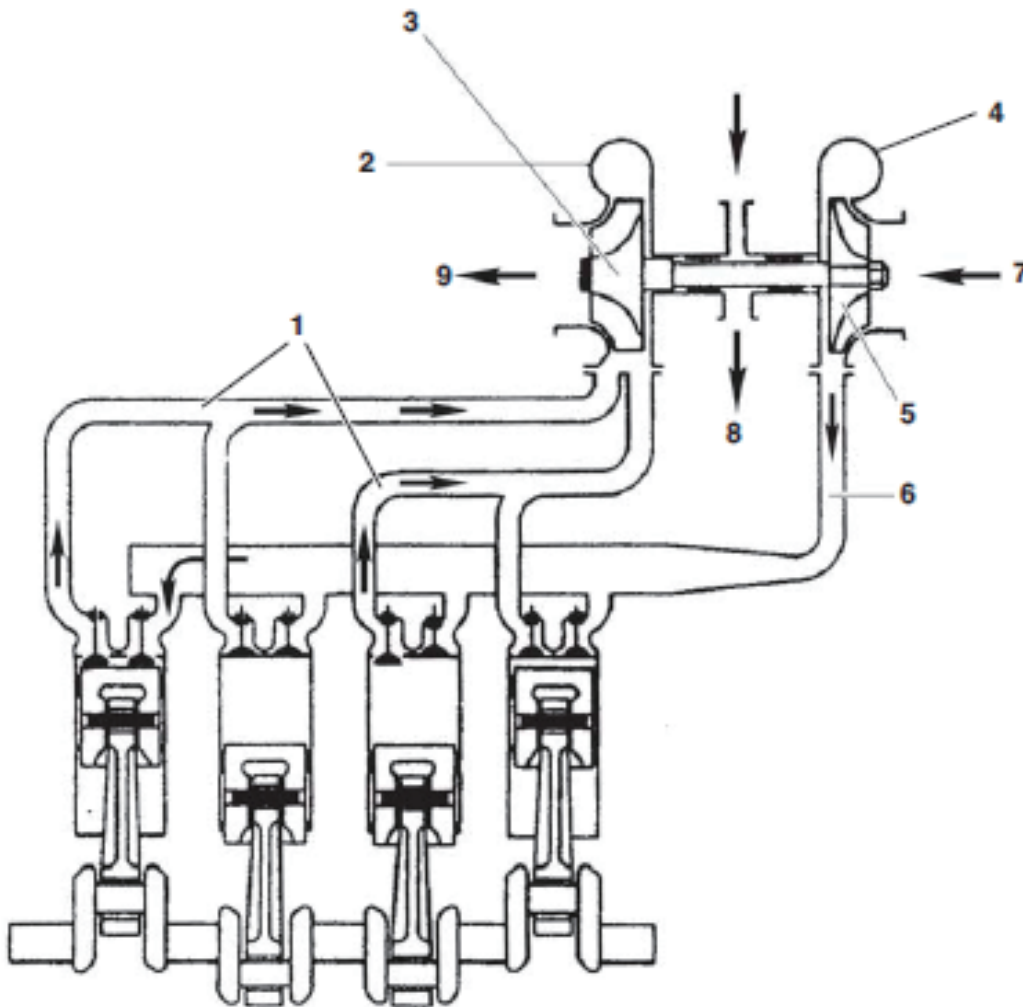

DS2103722

1	Exhaust manifold	4	Compressor housing	7	Air inlet
2	Turbine housing	5	Compressor wheel	8	Oil outlet
3	Turbine wheel and shaft assembly	6	Intake manifold	9	Exhaust outlet

### Function

1. Turbine: As exhaust gas discharged from the combustion chamber passes through the turbine housing, its energy is transferred to the turbine blades to deliver the rotating force to the turbine shaft. These series of motions are occurred in a component called turbine. The turbine is equipped with the seal ring and heat shield to prevent exhaust gas from affecting its bearing.
2. Compressor: As it is connected to the same shaft with the turbine, it rotates together to receive rotating force from the turbine shaft in order to receive, compress and send air to the intake manifold. This is the basic principle of a compressor.
3. Bearings: Thrust bearing: The turbine wheel is applied with axial force. This axial force keeps the shaft from moving.
4. Seal ring of compressor shaft: The shaft is equipped with the seal plate and seal ring in a dual structure to prevent leakage of compressed intake air and lubricant.

## Troubleshooting

Phenomenon	Causes	Troubleshooting
Noise or Vibration	Rotating part is contacted	Repair or replace it
	Unbalanced rotation of a rotor	Repair or replace it
	Burn	Repair or replace it
	Loose joint	Check or repair it
	Deformed or damaged intake unit hose	Replace it
	Poor clamping state	Adjust and tighten the clamp
	Contaminated or damaged air filter	Replace and check if the impeller of the turbocharger is damaged
	Leakage of coolant from the turbocharger or oil from the oil hose	Replace the hose and the gasket
	Leakage of gas from the exhaust manifold	Replace the gasket or tighten the fixing nut
	Poor turbo actuator operation	Replace the turbocharger
	Leakage from the engine block and the exhaust manifold	Check the engine
	Contaminated blowby gas and abnormal oil amount	Check the turbo impeller and the turbo intake and outlet
	Large gap of the turbocharger wheel, causing interference with the wall	Check if there is any sand or metallic foreign substance
	Damaged turbocharger wheel	Check if there is any sand or metallic foreign substance
	Damaged wheel and shaft of the turbocharger	Check if there is any sand or metallic foreign substance
Poor rotating force of the turbocharger wheel	Check if there is any sand or metallic foreign substance	



Phenomenon	Causes	Troubleshooting
Lowered Output	Leakage of gas from each part of the exhaust system	Check or repair it
	Clogged air filter element	Replace or clean it
	Contaminated or damaged turbocharger	Repair or replace it
	Leakage of air from the discharging part of the compressor shaft	Check or repair it
	Deformed or damaged intake unit hose	Replace it
	Poor clamping state	Adjust and tighten the clamp
	Contaminated or damaged air filter	Replace and check if the impeller of the turbocharger is damaged
	Poor turbo actuator operation	Replace the turbocharger
	Leakage from the engine block and the exhaust manifold	Check the engine
	Contaminated blowby gas and abnormal oil amount	Check the turbo impeller and the turbo intake outlet
	Large gap of the turbocharger wheel, causing interference with the wall	Check if there is any sand or metallic foreign substance
	Damaged turbocharger wheel	Check if there is any sand or metallic foreign substance
	Damaged wheel and shaft of the turbocharger	Check if there is any sand or metallic foreign substance
Poor rotating force of the turbocharger wheel	Check if there is any sand or metallic foreign substance	
Oil Leakage	Deformed or damaged intake unit hose	Replace it
	Poor clamping state	Adjust and tighten the clamp
	Contaminated or damaged air filter	Replace and check if the impeller of the turbocharger is damaged
	Leakage of coolant from the turbocharger or oil from the oil hose	Replace the hose and the gasket
	Poor turbo actuator operation	Replace the turbocharger
Oil Leakage	Leakage from the engine block and the exhaust manifold	Check the engine
	Contaminated blowby gas and abnormal oil amount	Check the turbo impeller and the turbo intake outlet
	Large gap of the turbocharger wheel, causing interference with the wall	Check if there is any sand or metallic foreign substance
	Damaged turbocharger wheel	Check if there is any sand or metallic foreign substance
	Damaged wheel and shaft of the turbocharger	Check if there is any sand or metallic foreign substance
	Poor rotating force of the turbocharger wheel	Check if there is any sand or metallic foreign substance

Phenomenon	Causes	Troubleshooting
Oil Consumption	Poor clamping state	Adjust and tighten the clamp
	Leakage of coolant from the turbocharger or oil from the oil hose	Replace the hose and the gasket
	Leakage from the engine block and the exhaust manifold	Check the engine
	Contaminated blowby gas and abnormal oil amount	Check the turbo impeller and the turbo intake outlet
	Large gap of the turbocharger wheel, causing interference with the wall	Check if there is any sand or metallic foreign substance
	Damaged turbocharger wheel	Check if there is any sand or metallic foreign substance
	Damaged wheel and shaft of the turbocharger	Check if there is any sand or metallic foreign substance
	Poor rotating force of the turbocharger wheel	Check if there is any sand or metallic foreign substance
Black and White Emissions	Deformed or damaged intake unit hose	Replace it
	Contaminated or damaged air filter	Replace and check if the impeller of the turbocharger is damaged
	Leakage of coolant from the turbocharger or oil from the oil hose	Replace the hose and the gasket
	Poor turbo actuator operation	Replace the turbocharger
	Contaminated blowby gas and abnormal oil amount	Check the turbo impeller and the turbo intake outlet
	Large gap of the turbocharger wheel, causing interference with the wall	Check if there is any sand or metallic foreign substance
	Damaged turbocharger wheel	Check if there is any sand or metallic foreign substance
	Damaged wheel and shaft of the turbocharger	Check if there is any sand or metallic foreign substance
	Poor rotating force of the turbocharger wheel	Check if there is any sand or metallic foreign substance
Blue Emissions	Leakage from the engine block and the exhaust manifold	Check the engine
Too much Fog	Oil leakage to the turbine or compressor	Repair or replace it
	Worn or damaged seal ring due to worn bearing	Repair or replace it
Too much Exhaust Emissions	Clogged air filter element	Replace or clean it
	Clogged air duct	Check or repair it
	Air leakage from the intake system	Check or repair it
	The turbocharger cannot rotate because of burning	Repair or replace it
	A turbine blade or compression wing contacts with the other one or is damaged	Repair or replace it
	Deformed or clogged exhaust system pipe	Check or repair it

## How to Maintain Turbocharger

### Cautions for Engine Operation

Observe the followings when starting, operating, and stopping an engine.

Item	Cautions	Reasons
Starting an Engine	Check the oil amount	
	Therefore, start the engine with the starter motor to check the rise of oil pressure (until the gradation of the oil pressure gauge moves or the pressure indicator lamp is turned on).	Overhasty start of engine leads to engine rotation without lubricating turbocharger and other engine parts, causing abnormal wear or burning of bearings.
	If you replace oil, oil filter cartridge, or lubrication system parts or use an engine in cold areas, or the engine has stopped for a long period, loosen the oil pipe joint at the inlet of the turbocharger and run the starter motor until oil flows out. After completing the work, tighten the oil pipe joint again and start the engine.	When an engine has stopped or kept cold for a long period, circulation of oil in the pipe gets poor.
After Starting an Engine	Operate the engine at idle for five minutes from starting it.	When the engine is suddenly loaded while the engine and the turbocharger have not been smoothly rotated after starting the engine, parts with insufficient oil may be burnt.
	Check if oil, gas, or air is leaked from each part. If so, take proper action.	Leakage of oil, gas, or air (especially oil) reduces oil pressure and loss of oil cause burning of bearings.
During Operation	check the following.	
	Oil pressure At idle: 1.5 ~ 3.0 kg/cm <sup>2</sup> (1.5 ~ 3.0 bar, 21.3 ~ 42.7 psi) Fully loaded: 3.0 ~ 5.5 kg/cm <sup>2</sup> (3.0 ~ 5.5 bar, 42.7 ~ 78.2 psi)	Too low oil pressure causes abnormal wearing or burning of bearings. Too high oil pressure causes oil leakage.
	When abnormal noise or vibration occurs, slowly reduce the rotate count until the engine stops and then figure out the causes.	Operating an engine with noise or vibration may cause irreversible damage of the engine.
Stopping an Engine	Operate the engine at idle for five minutes before stopping it.	Sudden engine stop after operating the engine under high load allows the heat from the red-heated turbine blade to be delivered to the bearing system. Then oil burns and the bearing metal and rotation shaft are burnt.

### Cautions for Maintenance

1. When the rpm is rapidly increased after starting the engine, the journal bearings in the crankshaft is excessively rotated, the crankshaft is rotated at excessive speed before the journal bearing of the crankshaft is lubricated fully. If the turbocharger rotates in this situation, bearings are not smoothly cooled and lubricated, causing bearing burn and damage of the related parts.

2. Please operate the engine for two minutes or more in order to lubricate the turbocharger fully after replacing the engine oil or oil filter.
3. If an engine has been operated at high speed for a long period, fully operate the engine at idle and then stop the engine. Otherwise, the turbine wheel continuously runs without oil pressure in the turbocharger. Therefore, no oil film is created on the center bearings and the journal bearings of the turbocharger, causing bearing, wearing out and shortening of the turbocharger lifetime.
4. If an engine is not operated for a long period during cold weather or in areas with cold climate, operate the engine at idle after starting the engine until the engine oil pressure is normal.
5. The turbocharger turbine spins at high speed of 50,000 ~ 200,000 rpm. Therefore, lubrication of bearings may determine the turbocharger lifetime. Please use only recommended genuine engine oil and check and replace the engine oil periodically.
6. Prolonged usage of contaminated air cleaner may cause a critical damage of the turbocharger. Regularly check and replace the air cleaner.
7. A turbocharger is a very complex and precise part. Only certified and skilled technicians should work on it.
8. If a turbocharger is operated without intake and exhaust pipe, serious human injury may occur and critical faults of the engine performance may occur. Please operate a turbocharger only when all of parts are exactly mounted on the specified position.
9. Do not lift up a turbocharger by grabbing the actuator. The actuator may be damaged because of the weight of the turbocharger.
10. The weight of a turbocharger is about 4.0 kg or more. To lift up a turbocharger for installing or removing it, the worker should lower the center of gravity or press his body close to the turbocharger. Otherwise, worker may drop the turbocharger, causing damage of the part and injury.

## **Inspection**

### Daily Inspection and Service

It is important to handle the engine and maintain its optimum condition according to the instructions as the performance of the turbocharger is highly affected by the maintenance condition of the engine.

#### 1. Intake system

In the intake system, the air filter should be maintained with care. For a wet type air filter, if the oil level is below the specified level, its filtering performance is deteriorated. On the other hand, if the oil level is too high, it sucks in oil and contaminates the case. Especially, if the rotor is contaminated, the precisely adjusted balance is destroyed and the bearing is applied with large force, resulting in vibration, seizure and abnormal wear. Therefore, the air filter should be well-maintained and handled

with care. A dry air filter should feature low possible intake air restriction.

## 2. Exhaust system

If exhaust gas is leaked from the exhaust pipe or turbocharger connection in the exhaust system, the turbocharger's performance is deteriorated. Extra care is needed to prevent a gas leak and seizure. A heat resisting steel nut is used for parts, which can become hot during driving, such as the turbine housing. Make sure not to mix it with a general nut, and apply screw's anti-seize compound to the specified mounting nut.

## 3. Lubrication system

In the lubrication system, the oil quality and the cartridge replacement interval of the oil filter should be monitored with care. Degraded engine oil can affect not only the engine body, but also the turbocharger negatively.

# Lubrication system

## General Information

### General Description

This engine is a forced lubrication type. Oil pressure is generated and supplied by rotation of the oil pump gear which is engaged with the crankshaft gear on the back of the cylinder block. After the oil pump sucks in oil from the oil pan through the suction pipe, this oil is sent to the main gallery of the cylinder block through the oil cooler and oil filter. Then, it is distributed to the crankshaft bearings, camshaft bearings and rocker arms in order to lubricate them. In addition, the turbocharger is connected to the engine lubrication circuit. Oil is sprayed around the cylinder block and timing gear for proper lubrication. Each cylinder has an oil injection nozzle for cooling the bottom of the piston. Foreign matter is removed from engine oil by the oil filter.

### Overview

Figure 101

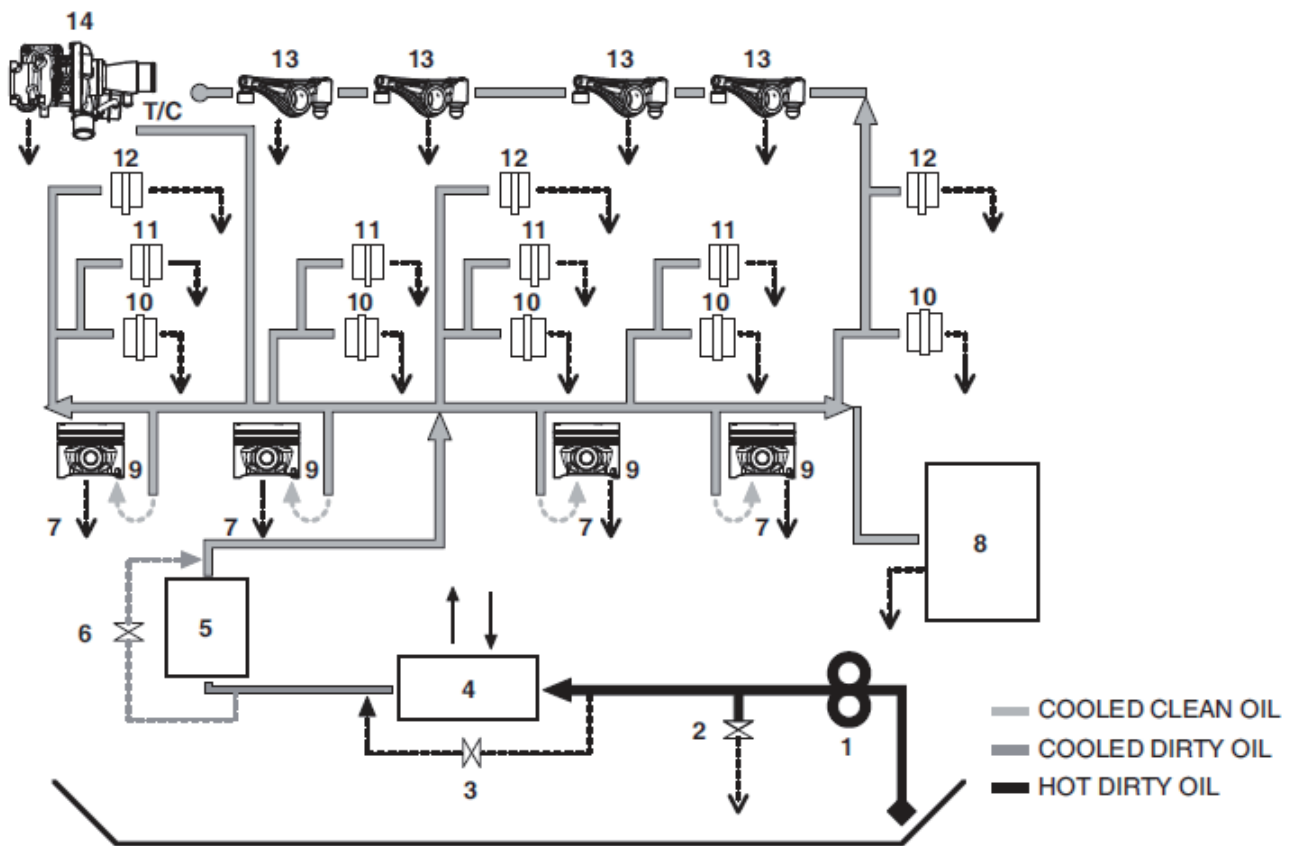

DS2103723

1	Oil pump	6	Bypass valve	11	Connecting rod bearings
2	Relief valve	7	Piston cooling jets	12	Camshaft bearings
3	Bypass valve	8	Idle gear	13	Rocker arms
4	Oil cooler	9	Piston	14	Turbocharger
5	Oil filter	10	Crankshaft main bearings		

## **Purpose of Lubrication by Oil**

### 1. Reduction of friction (Prevention of abrasion)

Lubrication maintains the least possible level of friction, and forms a stronger oil film in a critical state to prevent the surface friction on the perturbed section and subsequent defacement.

### 2. Sealing function

Prevents the leak of gas under a high-pressure in concurrence with the piston ring, just as in the cylinder lubrication.

### 3. Cooling function

Regionally absorbs the heat from parts located on higher spots, and discharge the heat again in a proper temperature through the oil cooler and other units

### 4. Stress dispersing function

Provides momentarily and regionally a great pressure to lubricated parts to destroy the oil film and raise adherence. At this point, the lubricant disperses the local pressure across the entire oil

### 5. Anti-rust function

Forms a lubricant film to keep any moisture from infiltrating into the lubricated surface to produce rust.

### 6. Oil purifying function

This absorbs alien materials such as carbon or metals produced at lubricated parts and store them in the oil filter

## **Applicable Oil**

Use only specified engine oil according to the environment and condition of the area.

**Figure 102**

### Engine Oil Viscosity by Temperature

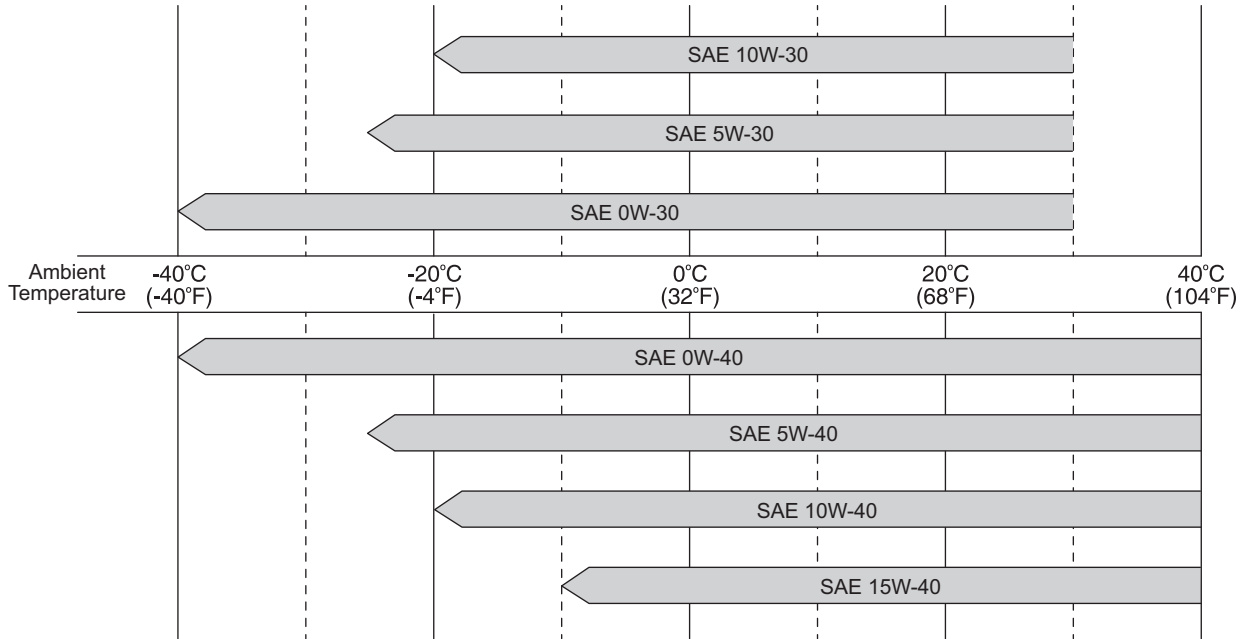

DS2100122

Make sure to use proper engine oil according to the following recommendation.

Oil Classification	Oil Grade	Capacity (L(U.S.gal.))		
		Maximum	Minimum	Total
SAE 10W40	API CJ-4 or Higher	24.5(6.5)	17.5(4.6)	26.5(7)

**NOTE:** Make sure to use the recommended genuine oil. Total capacity of engine oil includes 2.0 liter in engine.

## Oil Pump

### General Description

Engine oil is sucked from the oil pan by the gear type oil pump and then all of the oil is forcibly delivered to the oil cooler and filter for filtering. The filtered oil passes through the main oil path of the cylinder block and lubricates bearing parts and the turbocharger of the engine in order to maintain normal engine performance.



# Electrical System

## Electric Parts

Figure 103

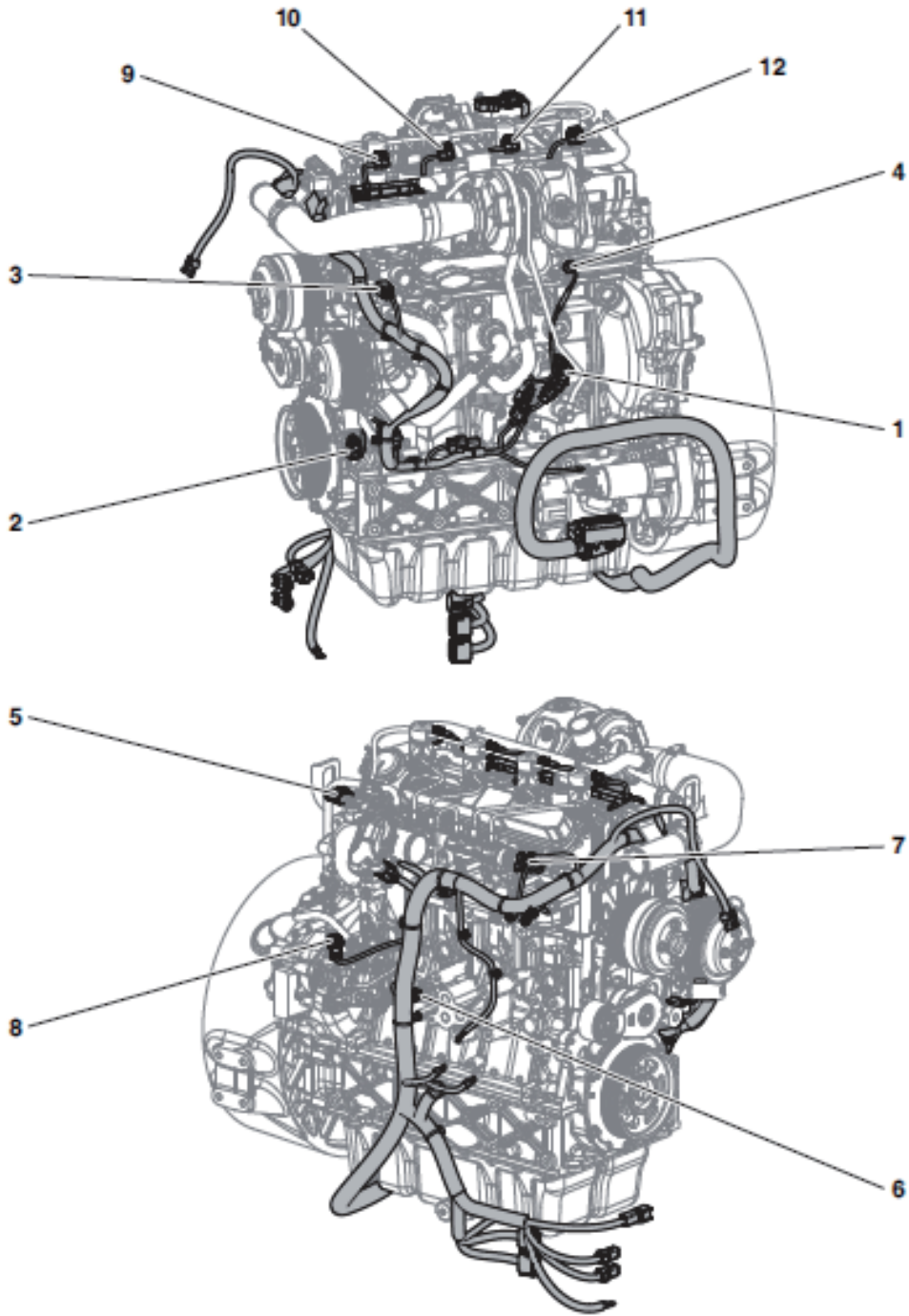

DS2103799

1	CAM: CAM shaft position sensor	5	T-MAP sensor	9	INJ: Injector 1
2	CRK: Crank shaft position sensor	6	OPS: Oil pressure sensor	10	INJ: Injector 2
3	WTS: Water temperature sensor	7	RPS: Rail pressure sensor	11	INJ: Injector 3
4	EGT: Exhaust gas temperature sensor	8	IMV: Inlet metering valve	12	INJ: Injector 4

- It is possible to identify the circuit number for the connector and engine wire harness information.

The ECU pin No. means each pin number of an engine connector.

The sensor pin No. means each pin number of a sensor connector.

## Switches and Sensors

### Engine Oil Pressure and Temperature Sensor

The engine oil pressure and temperature sensor detects the pressure and temperature of engine oil and sends this information to the ECU (Electronic Control Unit).

### Engine Coolant Temperature Sensor

The engine coolant temperature sensor detects the temperature of engine coolant and sends this information to the ECU (Electronic Control Unit).

### Common Rail Pressure Sensor

Fuel passes through the passage in the common rail before it heads to the common rail pressure sensor.

The tip of this pressure sensor is sealed with the diaphragm. After fuel is pressurized, it reaches the diaphragm of the sensor through the hole.

A sensor to convert a fuel pressure value into an electric signal is connected to this diaphragm. This sensor produces a signal by amplifying the detected value before it delivers the signal to the ECU (Electronic Control Unit) and evaluation circuit.

**Figure 104**

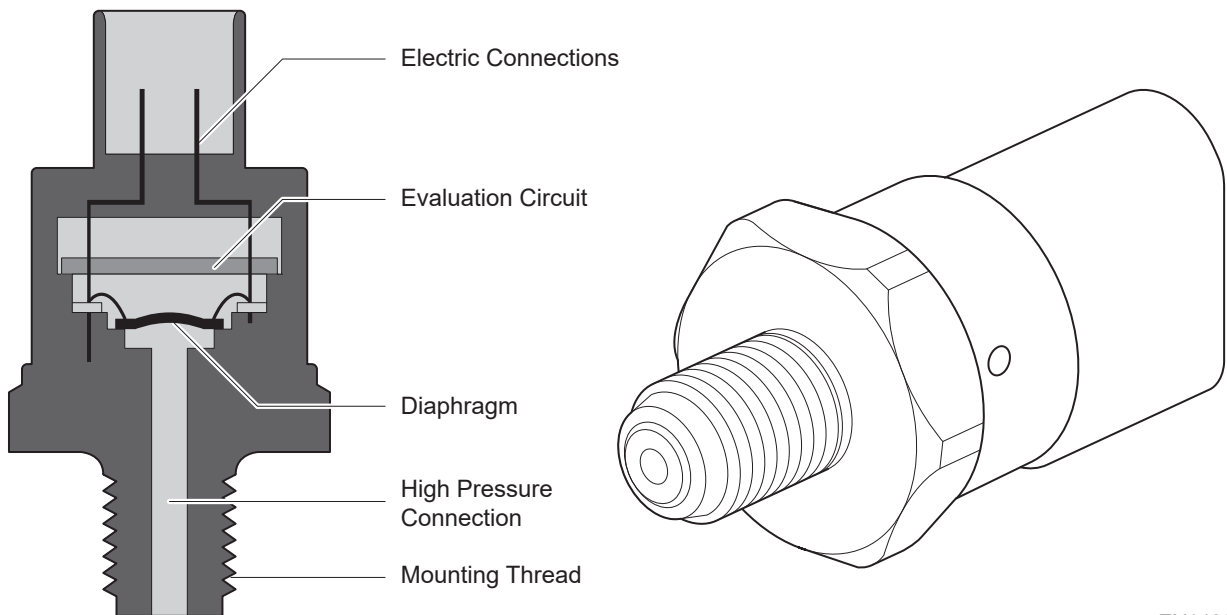

EX1403833

### Crankshaft Speed Sensor

The position of the pistons in the combustion chamber has a major role in the fuel injection process.

All pistons in the engine are connected to the crankshaft by the connecting rod.

The flywheel housing is equipped with the crankshaft speed sensor to supply information for the position of all pistons.

This speed sensor detects the rotation per minute of the crankshaft, and this information is used by the ECU (Electronic Control Unit) for calculation as an important factor.

### Camshaft Speed Sensor

The camshaft speed sensor is used to control the intake and exhaust valves of the engine.

This rotates at half speed of the crankshaft. When the piston is moving toward T.D.C., it determines whether the camshaft position is in the compression stage or in the exhaust stage.

This information cannot be detected by the crankshaft speed sensor.

On the other hand, during normal operation, information supplied by the crankshaft speed sensor is enough to tell the condition of the engine.

In other words, if the camshaft speed sensor cannot detect the camshaft position while the engine is running, the ECU (Electronic Control Unit) receives engine condition information from the crankshaft speed sensor.

### Pressure Limiter Valve

1. The pressure limiter valve is connected to the end of the common rail, and its body houses a conical plunger valve in it. This valve is normally closed by force of the spring at a normal operating pressure (1,800 bar (1,835.5 kg/cm<sup>2</sup>, 26,106.8 psi)) to keep the pressure in the common rail.
2. As soon as the pressure exceeds the operating pressure limit, load is applied to the spring of the valve to keep the fuel pressure at a normal level. After fuel passes through the valve, it is returned to the fuel tank through the return pipe.

### Fuel Metering Unit

A valve mounted on the high-pressure pump. It adjusts the fuel volume pumped from the pump to the rail to control the fuel pressure on the rail.

### ECU (Electronic Control Unit)

The engine control unit (ECU) is used to control fuel delivery. The engine control unit is connected to various types of sensors and provides control based on the values received from these sensors to enable the engine to run in an optimal state. In cases where the connectors of the engine control unit must be disconnected, be sure to disconnect the negative (ground) terminal of the battery cable first. Do not disassemble the inside of the engine control unit (ECU).

Figure 105

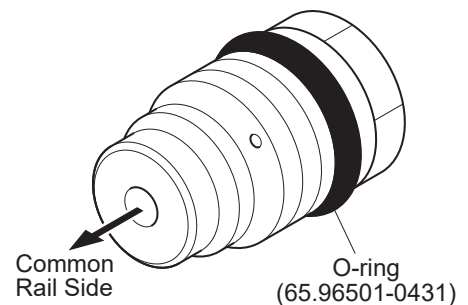

EX1404193

Figure 106

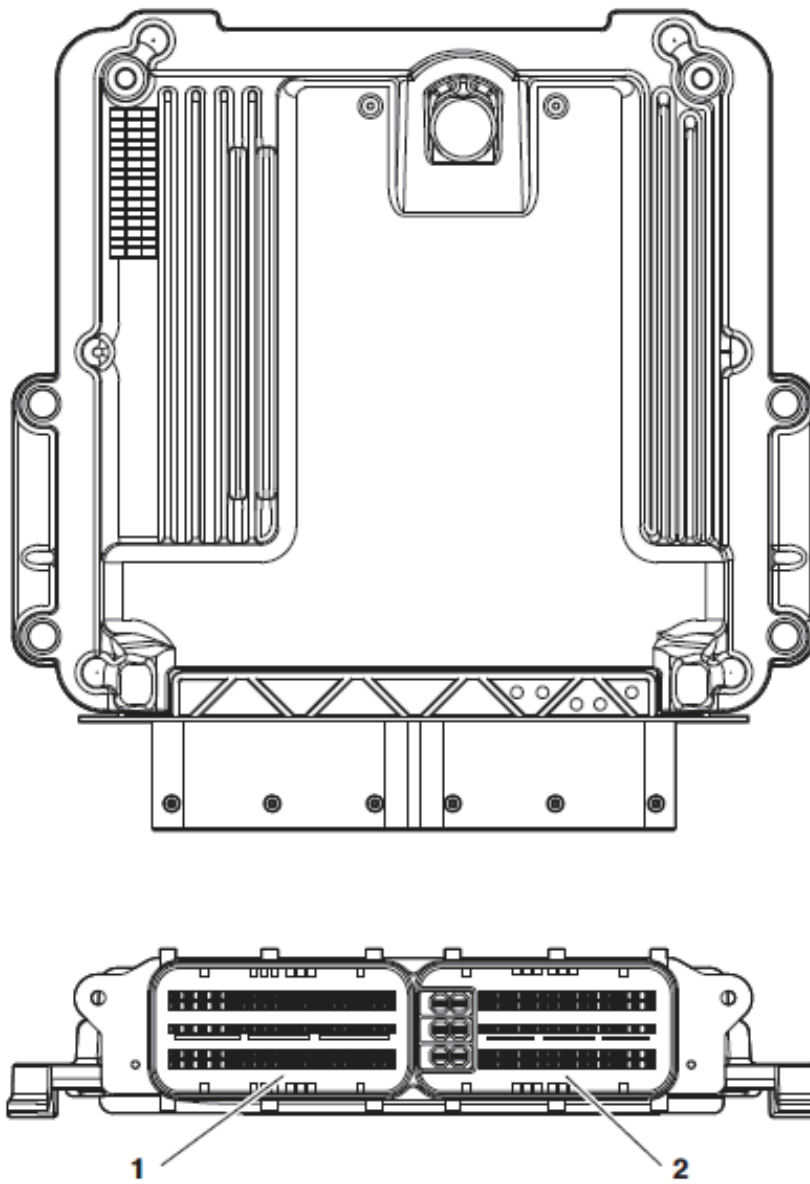

DS2103801

1	Connectors for Connections on the Engine	2	Connectors for Connections on the Vehicle
---	--	---	---

## ECU (Electronic Control Unit) input/output

Figure 107

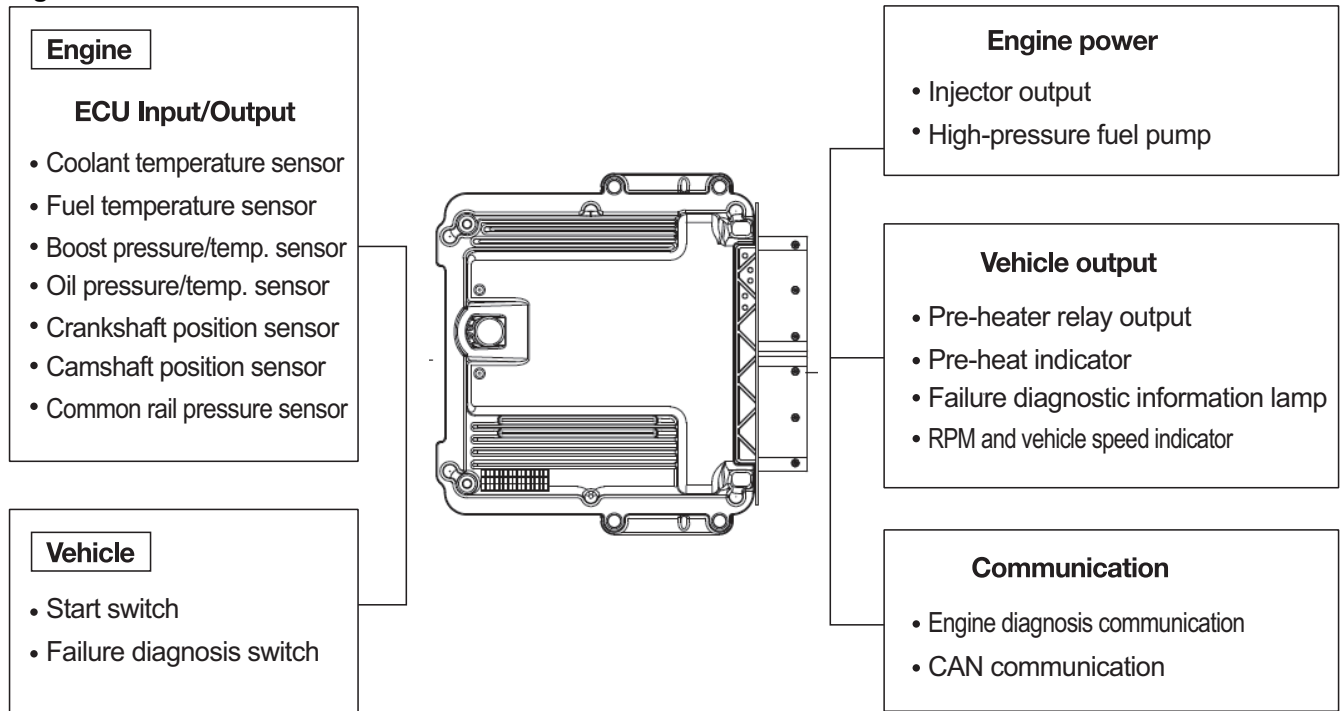

DS2103800

## Operational Conditions of Electronic Control Unit (ECU)

### Engine Start

1. Sets the lowest value among the coolant temperature, fuel temperature, intake air temperature and oil temperature as the reference temperature in order to set the reference temperature for determining whether to preheat the engine.
2. Sets the reference temperature based on the engine coolant temperature in order to set the reference temperature for determining the amount of fuel.
3. Delivers fuel to the engine after determining a suitable amount of fuel for starting the engine, then uses the crankshaft rotation sensor to measure the engine rpm signal.

### Vehicle Driving

Calculates the required data for driving a vehicle, such as CAN data and the rpm transferred from the vehicle control unit.

### Driver-requested Adjustment of rpm

Controls the rpm based on request from the driver and controls the engine based on the rpm requested by the vehicle control unit.

### Limp Home

1. A function that allows drivers to drive their vehicle to the repair center safely with the minimum conditions for driving the vehicle when a fault code occurs.
2. Limp Home function is applied under the following conditions.

- Accelerator pedal has failed: Regardless of pressing the accelerator pedal, the vehicle is driven at a consistent RPM.
- Sensor has failed: When sensors have failed, the vehicle is driven with the consistent alternative values.
- Output is limited: According to the fault type, the fuel volume delivered to the engine is limited. The limit is classified into four levels. The fuel volume is limited according to the severity of the fault.
- Diagnosis Information display lamp: Provides information of fault state to drivers for safe driving.

### Failure Diagnosis

1. When a fault occurs, the failure diagnosis information display lamp on the gauge board is turned on.
2. With the failure diagnosis information display lamp, drivers can see the fault code.

**NOTE:** *It can be checked from the failure diagnosis information on the gauge board.*

3. It can be diagnosed by connecting the diagnosis unit to the check connector at the back of the driver's seat.

### Driving Record

1. Writes the information related driving to the ECU.
2. The information on fuel consumption, engine use time, and ECU use time is written in the ECU.
3. The information can be monitored with the ECU diagnosis device.

## **Starter**

### **General Description**

The start motor is installed behind the flywheel housing. When disassembling the engine, soak the start motor's pinion gear and ring gear into fuel and clean them with a brush thoroughly. Then, apply grease to them prevent their corrosion.

Figure 108

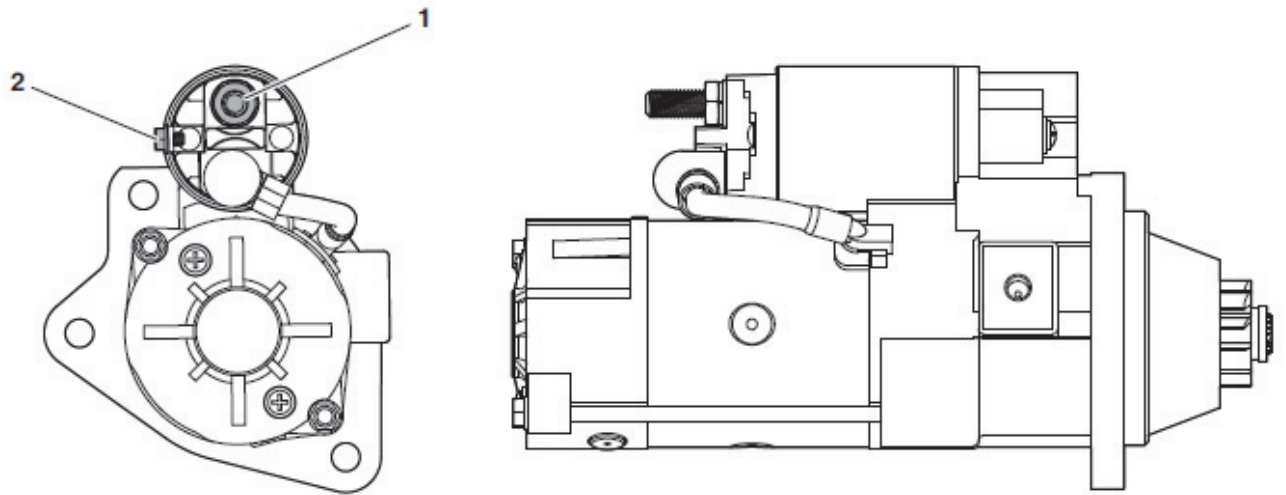

DS2103802

1	B terminal: M10 * 1.5P	2	S/W terminal: M5 * 0.8P
---	------------------------	---	-------------------------

---

**⚠ NOTICE**

---

The start motor should always be protected from moisture and humid condition.

---

## Circuit Diagram

Figure 109

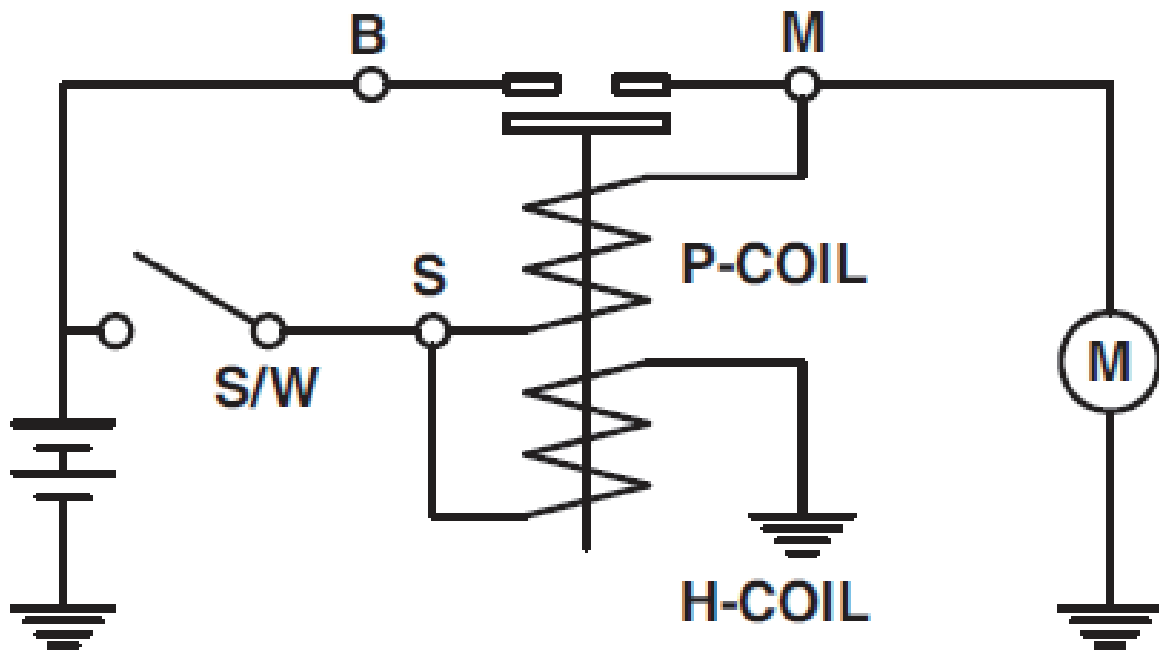

DS2103803

---

### **⚠ NOTICE**

---

Before working on any electric system, make sure to disconnect the negative battery cable in advance. Connect the ground cable last after work to avoid a short circuit during work.

---

### **Alternator**

The alternator is fitted with integral silicon rectifiers. A transistorized regulator mounted on the alternator body interior limits the alternator voltage. The alternator should not be operated except with the regulator and battery connected in circuit to avoid damage to the rectifier and regulator.



Figure 110

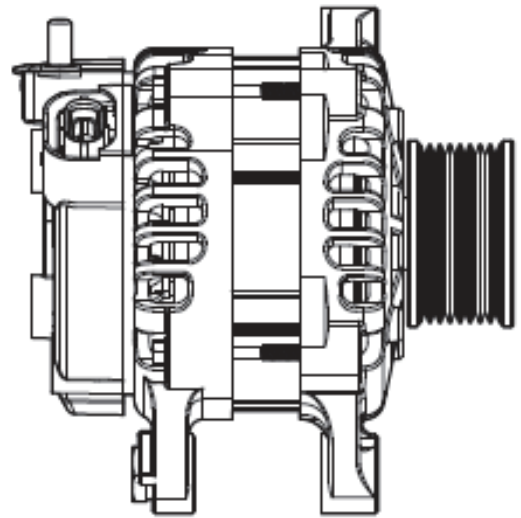
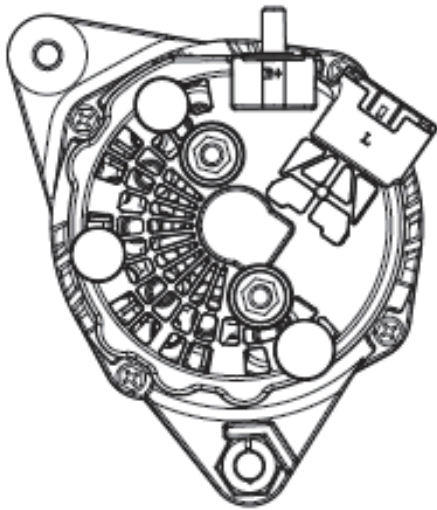

DS2103804

# After Treatment System

## Exhaust gas reduction system

### General instructions

The engine is designed to satisfy Stage-V emissions standards through the use of DOC (Diesel Oxidation Catalyst), SDPF (SCR-coated Diesel Particulate Filter), and SCR (Selective Catalytic Reduction) systems. The SCR system consists of a dosing module, supply module, ECU (engine control unit) and various other parts. DEF (Diesel Exhaust Fluid, urea solution) — necessary for the operation of the SCR system — is stored in the DEF tank before being pressurized by the supply module and supplied to the dosing module at a certain pressure. Installed on the muffler of the aftertreatment system, the dosing module injects DEF into the compact mixer located upstream of the SCR.

Figure 111

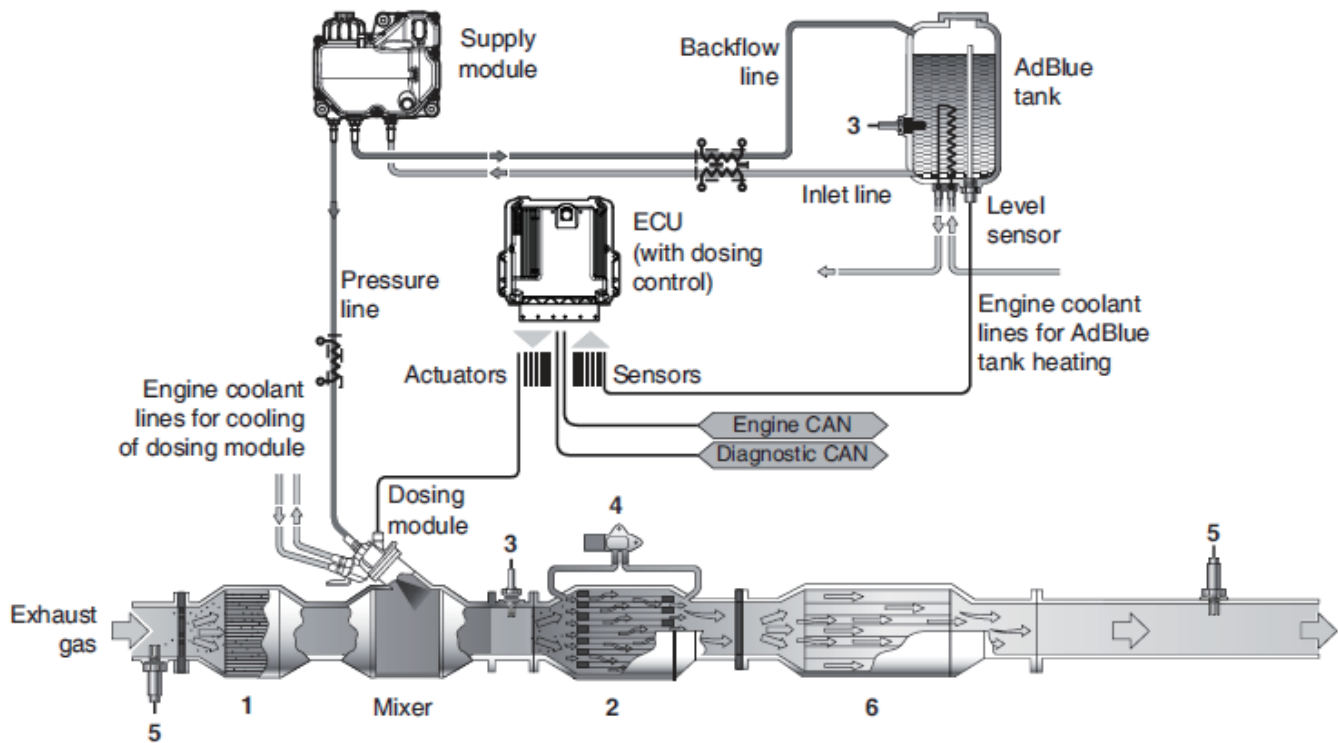

DS2103805

No.	Part Name	Quantity
1	DOC (Diesel Oxidation Catalyst)	1
2	SDPF (SCR coated Diesel Particulate Filter)	1
3	Temperature Sensor	1
4	DPF Delta P Sensor	1
5	NOx Sensor	2
6	SCR (with AOC)	1

**Aftertreatment muffler and catalyst**

The aftertreatment consists of the DOC + mixer and the SDPF + SCR/AOC. The DOC contains a diesel oxidation catalyst, while the SDPF + SCR contains an SCR-coated diesel particulate filter and selective catalytic reduction.

**Figure 112**

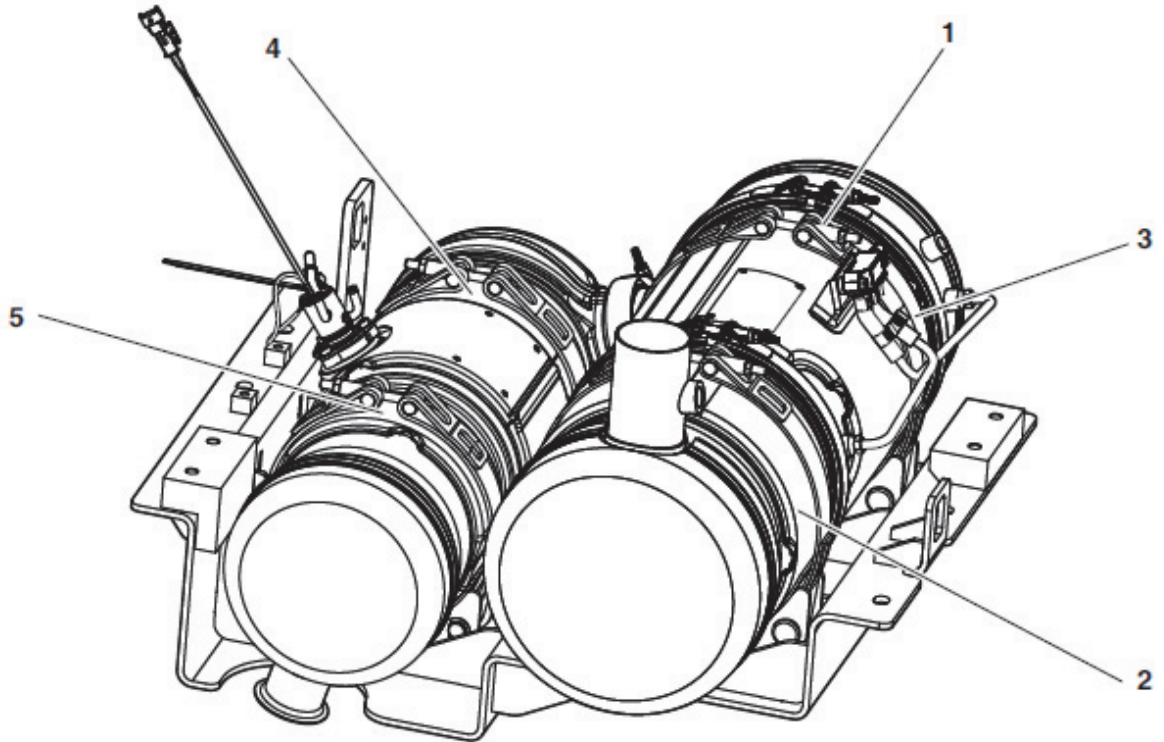

DS2103806

1	Band clamp	3	SDPF	5	DOC
2	SCR/AOC	4	Compact mixer		

## DNOX 2.2 EVO system

The DNOX 2.2 EVO system injects DEF (Diesel Exhaust Fluid, urea) into the SCR catalyst to reduce NOx (nitrogen oxide) emissions. The system consists of a supply module acting as a pump, a dosing module which injects DEF, an ECU which controls the entire system, a DEF tank for storing DEF, and DEF/coolant lines.

**Figure 113**

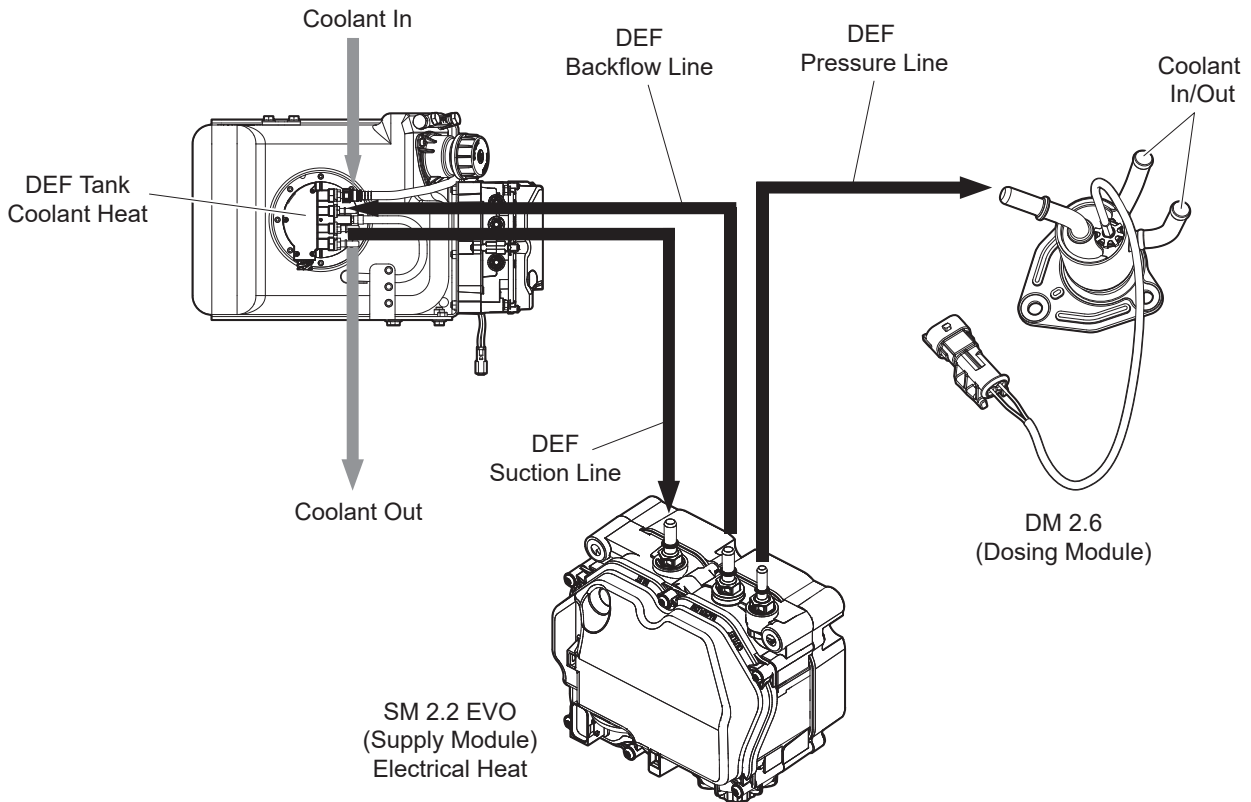

DS2002219

## DEF Tank

The DEF tank is used to store DEF (urea). Be sure to install connecting lines in their designated positions. Take care not to apply any excessive force or shocks to the DEF tank.

**Figure 114**

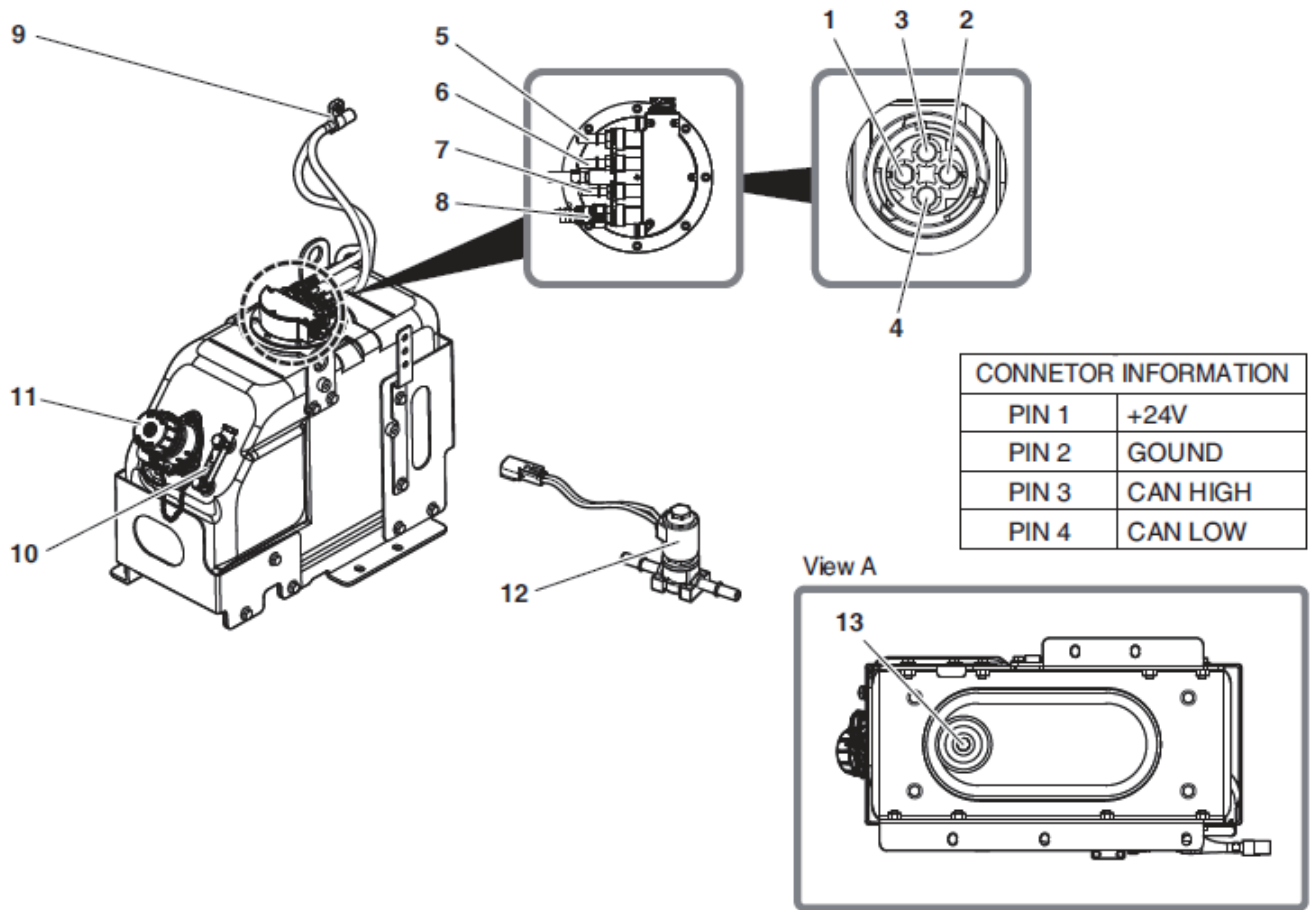

DS2103807

Reference Number	Description
1	+24V (Pin No.1)
2	Ground (Pin No.2)
3	CAN HIGH (Pin No.3)
4	CAN LOW (Pin No.4)
5	Coolant outlet
6	DEF outlet
7	DEF inlet
8	Coolant inlet
9	Breather filter
10	Level indicator
11	DEF tank cap
12	Coolant valve
13	Drain Plug

## Supply Module

The supply module is a device which pressurizes DEF in the DEF tank to a constant pressure and delivers it to the dosing module.

**Figure 115**

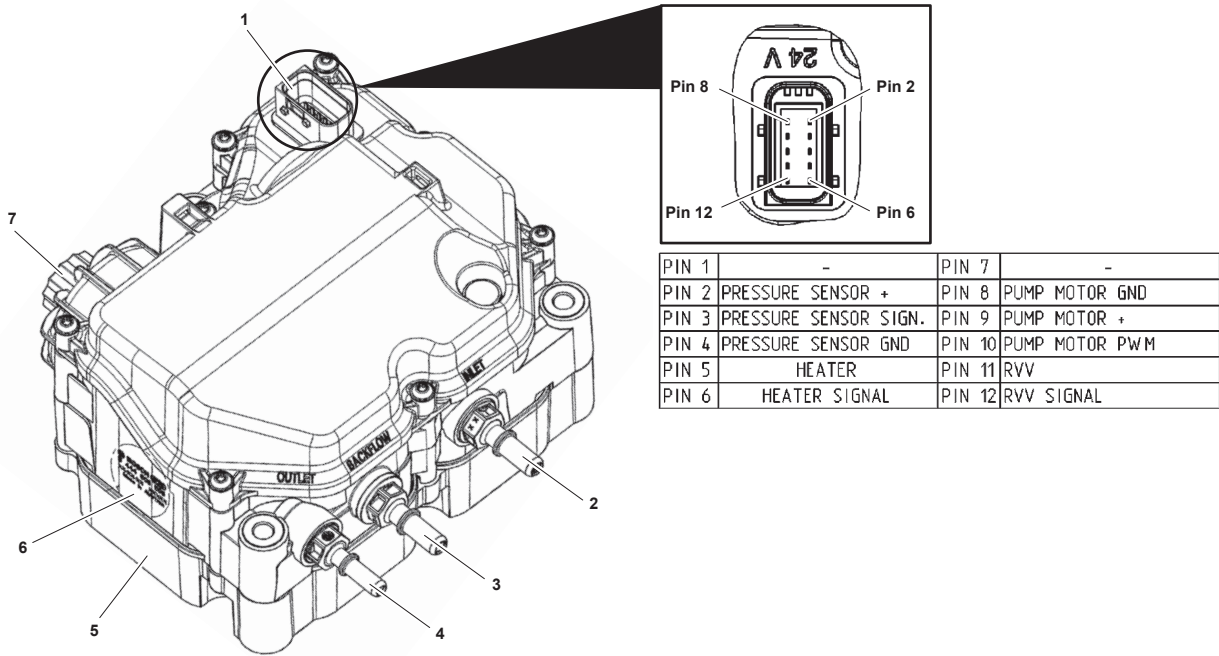

DS1901841

DS1901842

Reference Number	Description
1	Connector
2	DEF Outlet
3	DEF Back flow Outlet
4	DEF Outlet
5	Cover Plate
6	Detailed Display
7	Filter Cover

## Dosing Module

Installed on the compact mixer located upstream of the SCR, the dosing module is a device which injects DEF supplied by the supply module into the compact mixer.

**Figure 116**

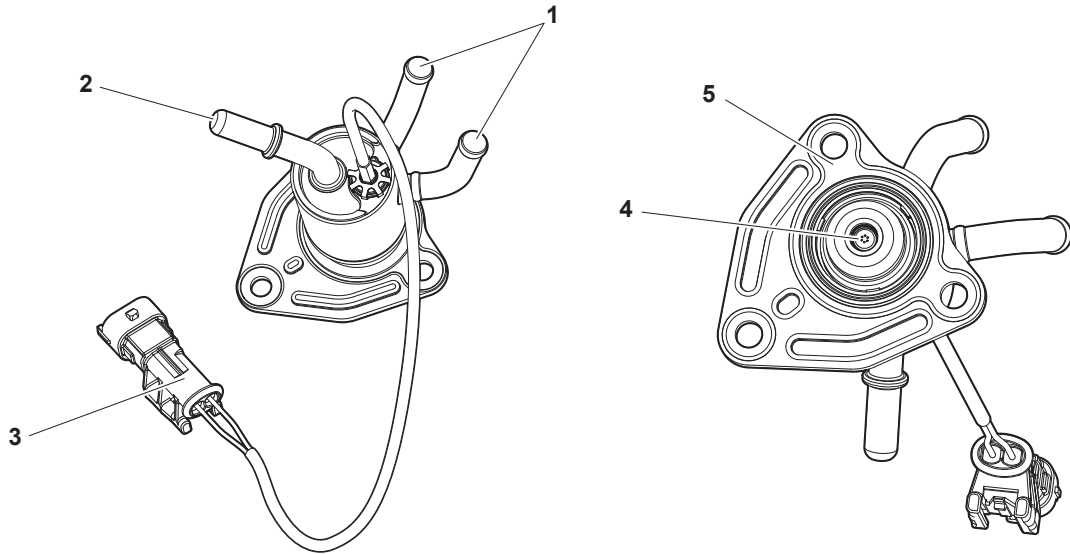

DS1901843

Reference Number	Description
1	Coolant Inlet/Outlet
2	DEF Inlet
3	Connector
4	DEF Outlet
5	Flange

## Components of the DNOX 2.2 EVO system

1. The DEF tank and supply module are both installed in the same cabin.

The components of the DNOX 2.2 EVO are installed throughout the vehicle where they are most essential. Each part is designed to be protected from damage due to the surroundings.

2. The dosing module (DM) is mounted on the compact mixer between the DPF and SCR. It is connected both to a DEF line passing through the SM and an engine coolant line, as well as to the connector of pin no.2 which controls the DEF dosing valve.

Figure 117

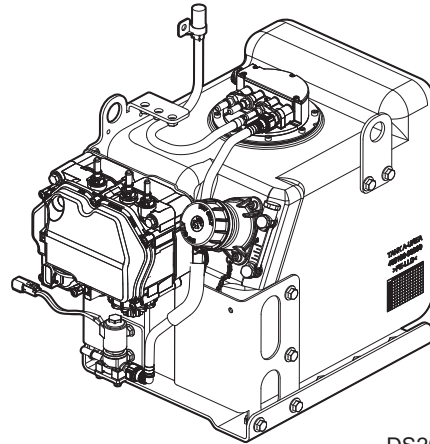

DS2002217

## Inspecting the DNOX 2.2 EVO system for faults

### 1. Dosing Module

Dosing module malfunctions may be caused by the tip of the DEF injection nozzle being exposed to high temperatures, a faulty connection in the electrical harness, or a damaged or improperly connected DEF hose line.

The following DM fault inspection items can be checked visually.

- A. Air leak due to insufficiently tightened bolt or DM and bolt damaged due to overtightened bolt during replacement or installation of DM.
- B. Improperly installed electrical connector or connector contaminated by foreign matter.
- C. DEF leak due to improperly connected DEF line.
- D. Coolant leak due to improperly connected coolant line or DM exposed to high temperatures due to disconnected coolant line.
- E. DM exposed to high temperatures due to improperly installed gasket.
- F. DEF leak due to reuse of gasket.

Figure 118

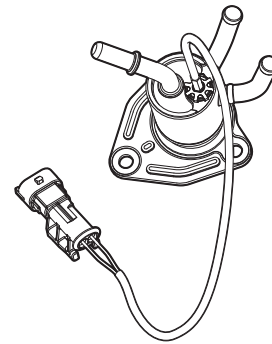

DS1901855



## 2. Supply Module

Supply module (SM) fault modes may be caused by damaged or improperly connected DEF lines and electrical connectors.

Faults may occur due to incorrect installation during regular replacements of the main urea filter.

---

### **WARNING**

---

#### AVOID DEATH OR SERIOUS INJURY

When replacing a filter, remove the packaging on the new filter immediately before performing the replacement.

---

- A. Fault due to improper assembly or improperly connected line while connecting DEF lines.
  - B. Improperly installed electrical connector or connector contaminated by foreign matter.
  - C. Filter damaged due to use of improper tools during replacement of SM filter or residue build-up in SM filter.
  - D. Cap damaged by over tightening of DEF cap during replacement of filter or filter loose due to incorrect installation.
3. The DEF tank is used to store DEF (urea). Be sure to install connecting lines in their designated positions. Take care not to apply any excessive force or shocks to the DEF tank.

DEF Tank

**Figure 119**

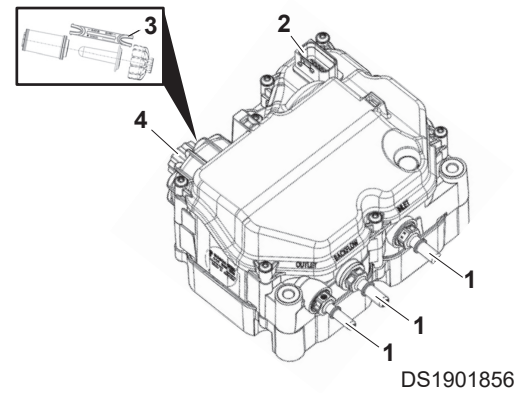
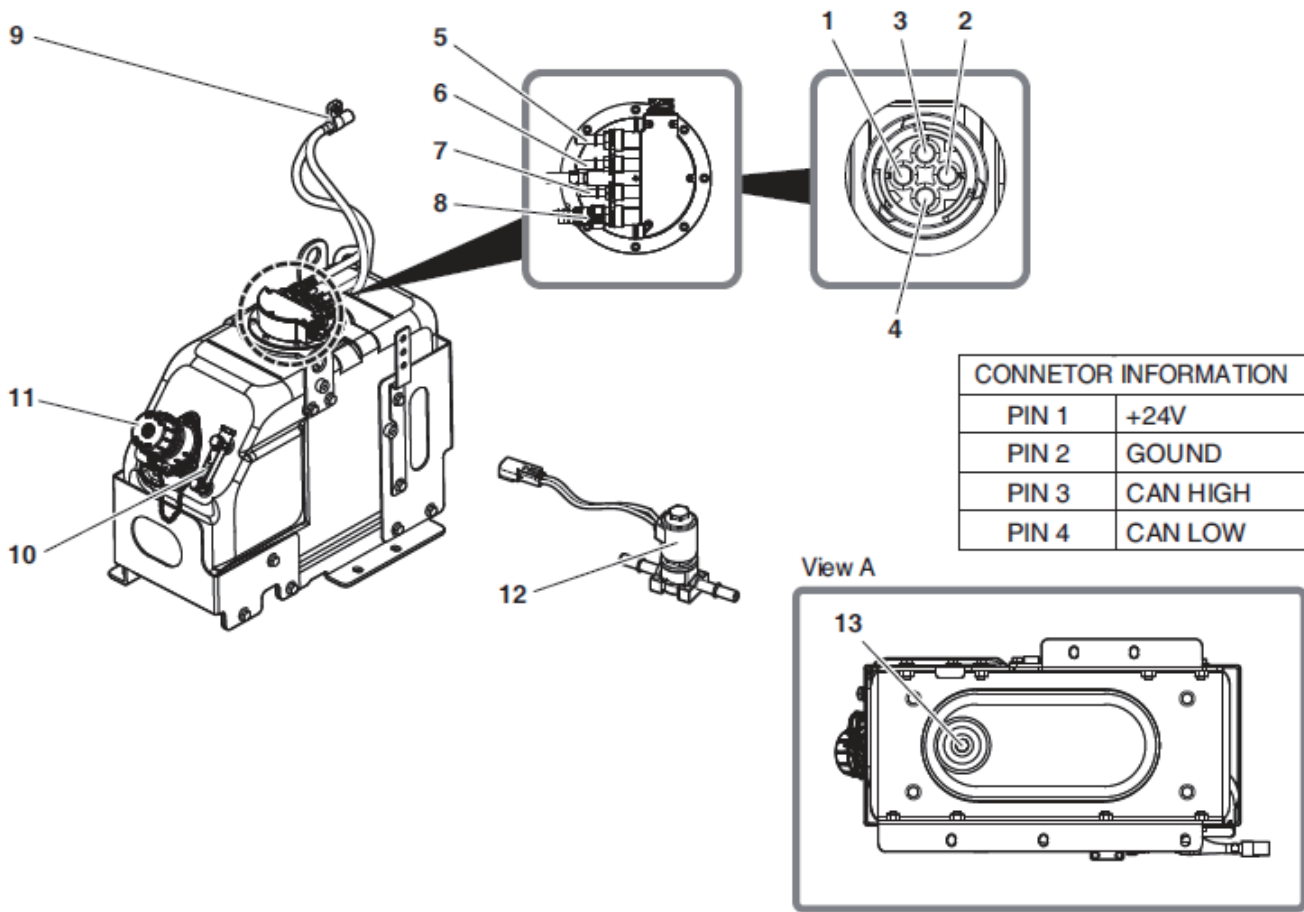

Figure 120



DS2103807

A. Do not mix up the DEF inlet hose and back flow hose. To install connectors, insert them until a click is heard, taking care not to damage the connectors.

**⚠ WARNING**

**AVOID DEATH OR SERIOUS INJURY**

The DEF inlet hose is shown in red, whereas the back flow hose is shown in yellow.

- B. Check whether the DEF tank mounting bracket has been tightened. Failing to tighten it may lead to damage due to vibrations.
- C. Check the tank temperature and the connection of the level sensor connector, taking care to avoid damaging or contaminating the connector with foreign matter
- D. Coolant lines must be installed in their proper positions. Failing to tighten coolant lines may cause coolant leakage.
- E. Check the connection of the DEF line heater (2-PIN). There is a risk of freezing and bursting in winter if the heater is not working.

#### 4. Muffler and other pipes

There is no need to replace, remove, or change the position of the installed muffler and various pipes except in the event of a fault or problem due to external factors.

When replacing or removing them due to a fault or problem, be sure to tighten each part to its specified tightening torque in order to prevent air leaks.

#### DEF (Diesel Exhaust Fluid, urea)

Component	Unit	Range		Test Method
		Minimum	max	
Urea concentrations	% (m/m) <sup>b</sup>	31.8	33.2	ISO 22241-2 Annex B <sup>c</sup> ISO 22241-2 Annex C <sup>c</sup>
Density (at 20°C <sup>d</sup> )	kg/m <sup>3</sup>	-	1,093	ISO 3675 or ISO 12185
Deflection (at 20°C <sup>e</sup> )	-	-	1.3843	ISO 22241 2 Annex C
Ammonia alkaline	% (m/m) <sup>b</sup>	-	0.2	ISO 22241 2 Annex D
Diuret	% (m/m) <sup>b</sup>	-	0.3	ISO 22241 2 Annex E
Aldehyde	mg/kg	-	5	ISO 22241 2 Annex F
Insoluble matter	mg/kg	-	20	ISO 22241 2 Annex G
Phosphate (PO4)	mg/kg	-	0.5	ISO 22241 2 Annex H
Calcium	mg/kg	-	0.5	ISO 22241 2 Annex I
Iron	mg/kg	-	0.5	
Copper	mg/kg	-	0.2	
Zinc	mg/kg	-	0.2	
Chrome	mg/kg	-	0.2	
Nickel	mg/kg	-	0.2	
Aluminum	mg/kg	-	0.5	
Magnesium	mg/kg	-	0.5	
Sodium	mg/kg	-	0.5	
Potassium	mg/kg	-	0.5	
Identity	-	Identical		ISO 22241 2 Annex J

1. Reference value: 32.5% (m/m).
2. The unit “%(m/m)” is used to express the mass of matter as a fraction according to international standards.
3. Calculated without subtracting nitrogen from ammonia.
4. Reference value: 1,090 kg/m<sup>3</sup>
5. Reference value: 1.3829

AUS 32 requires the addition of a tracer element. Take care to ensure that the quality of AUS 32 indicated in the table and the tracer element do not damage the SCR system.

**NOTE:** *The conditions of ISO 4259 must be applied between the maximum and minimum values within the specified range. Be sure to take the minimum difference of 4 x R*

(*R* is the reproducibility of the test method) into account. However, for the sake of maintaining high quality,  $4 \times R$  is not factored into the urea concentration.

**NOTE:** The urea concentration, density and deflection are the actual values. (For the actual values, please refer to ISO 4259)

**NOTE:** The values defined in notes a, d and e are standard among AUS 32 manufacturers.

**NOTE:** Be sure to check whether the DEF (Diesel Exhaust Fluid, urea) satisfies the required specifications. Be sure to apply the conditions of ISO 4259.

## Diesel oxidation catalyst (DOC)

### Outline

The diesel oxidation catalyst (DOC) is a device which oxidizes and eliminates HC (hydrocarbon) and CO (carbon monoxide) emissions. It also serves to increase the temperature of the DPF to help with the oxidation of diesel fuel injected into the engine combustion chamber during DPF regeneration. In addition, the DOC accelerates the passive regeneration of particulate matter (PM) collected in the DPF by converting NO (nitrogen monoxide) into NO<sub>2</sub> (nitrogen dioxide).

As shown in the figure below, a temperature sensor is installed on the front of the DPF (Diesel Particulate Filter) to control the DOC temperature during regeneration.

## Diesel particulate filter (DPF)

### Overview

The DPF (Diesel Particulate Filter) system serves to prevent particulate matter (PM) in emissions from being discharged into the air and consists of the DPF body, three exhaust gas temperature sensors, and one differential pressure sensor. The DPF is composed of a porous wall capable of filtering out particulate matter. As exhaust gas passes through the DPF, particulate matter accumulates in the DPF, while the rest of the exhaust gas travels through the DPF to the SCR system. Following this, PM collected in the DPF is eliminated using a suitable regeneration method.

### DPF Regeneration

The DPF serves to filter out soot, a contaminant found in the emissions of diesel engines. An excessive build-up of soot in the DPF leads to issues such as a drop in engine power due to increased back pressure in the engine, making it crucial to perform regeneration in order to eliminate PM in the DPF.

The ECU (Engine Control Unit) calculates the amount of exhaust smoke using the signal from the DPF differential sensor, the vehicle operating time, the vehicle fuel consumption, and engine simulation data. Once this amount reaches a certain level, the ECU performs DPF regeneration.

Regeneration—a process which involves burning accumulated PM—increases the temperature upstream of the DOC by means of adjustment of the engine throttle and post injection, as well as

Figure 121

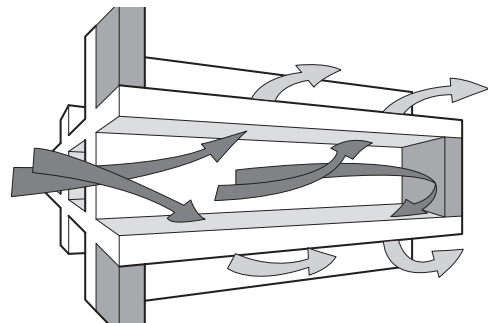

DS1901859

raising the DPF temperature higher than the soot combustion temperature (580° or higher) to burn soot.

After DPF regeneration, only ash remains in the DPF.

DPF regeneration comprises forced regeneration while driving (Active Regeneration) and manual regeneration performed by the driver (Forced Regeneration).

### DPF Regeneration lamp and switch

#### 1. HEST (High Exhaust System Temperature) Lamp

This lamp notifies the driver when hot exhaust gas is being discharged from the engine during DPF regeneration. Be sure to keep the area around the exhaust manifold free of flammable materials.

**Figure 122**



DS1901860

#### 2. DPF Regeneration Lamp

This lamp turns on either during regeneration or when regeneration is needed and turns off during active regeneration while driving if the soot level is less than 100%.

The lamp appears as shown on the right when the driver disables regeneration.

**Figure 123**

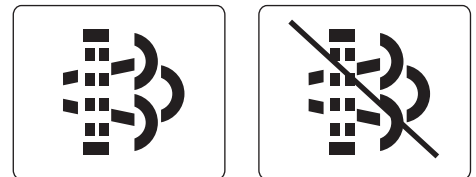

DS1901861

#### 3. Forced Regeneration

The driver can use these switches to initiate or disable forced regeneration. The switch above is the switch for forced regeneration and the switch below is the switch for disabling regeneration.

**Figure 124**

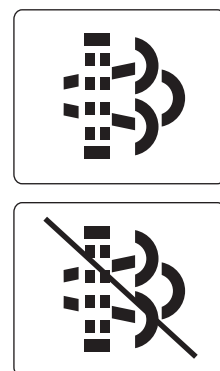

DS1901862

Stage V DPF Regeneration Strategy

Figure 125

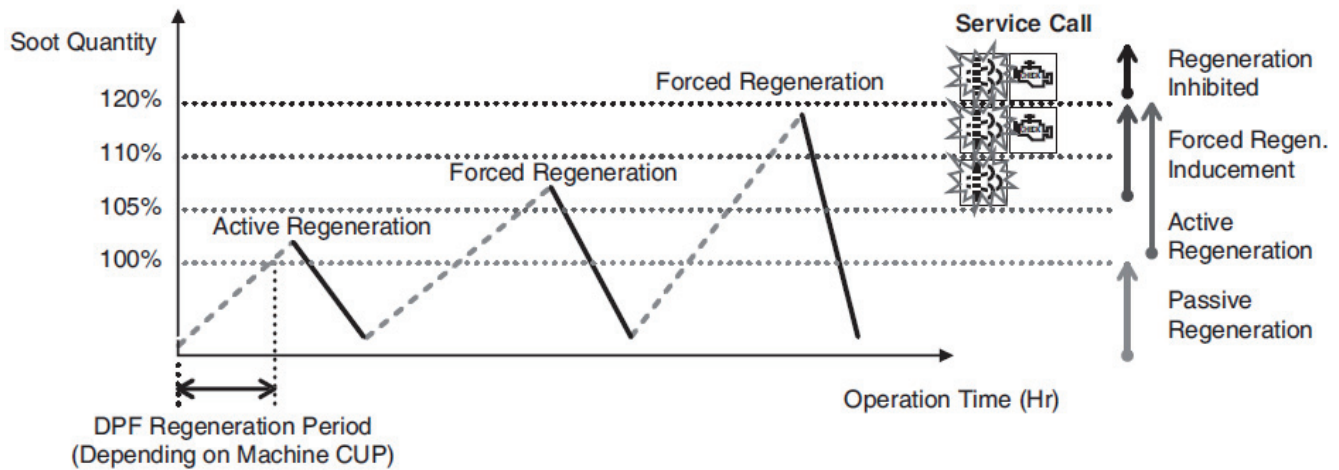

DS2103808

Step	Soot Quantity	DPF Lamp*	Check Engine Lamp	Torque derated	Remark
1	Below 99%	Off	Off	No	• No action (Passive regeneration dependent on machine CUP)
2	100% ~ 105%	Off	Off	No	• Start active regen. With high temp. (580 ~ 640°C) during running
3	106% ~ 110%	Slow Blink	Off	No	• Forced regeneration inducement (Alarm only) • Start active regen. with high temp. (580 ~ 640°C) during running
4	111% ~ 120%	Slow Blink	On	Mild Torque de-rate	• Forced regeneration inducement (Torque de-rate) • Start active regen. with high temp. (580 ~ 640°C) during running
5	Above 121%	Fast Blink	Blink	Severe Torque de-rate	• Forced regeneration is disabled. • Service call is needed to service regeneration for machine operating properly.

DPF regeneration consists of active regeneration which occurs while driving and forced regeneration which is activated manually by the driver. When the DPF soot level is less than 105%, active regeneration is activated automatically while driving. However, at 105% or higher, the system notifies the driver that forced regeneration must be performed manually. At 120% or higher, the engine warning lamp turns on, engine power drops 50%, and the driver must call for service.

- DPF soot level 105% or less: Active regeneration
- DPF soot level 105 ~ 120%: Forced regeneration + decrease in engine power
- DPF soot level 105 ~ 120%: Notify the driver that forced regeneration needs to be performed

- DPF soot level 120% or higher: Regeneration is not possible/must call for service to regenerate the DPF

### DPF Regeneration methods

Stage V engines are designed to perform passive regeneration of soot accumulated in the DPF even under normal exhaust conditions without needing to be initiated by the driver. The DPF regeneration modes are divided into the following five stages depending on the level of soot build-up in the DPF.

1. Soot level less than 100%: Normal operating conditions
2. Soot level 100 ~ 105%: Automatic regeneration during operation (Active Regeneration)
3. DPF soot level 106 ~ 110%: Forced regeneration is induced + Active regeneration is try to start.Notify the driver that forced regeneration needs to be performed.
4. DPF soot level 111 ~ 120%: Forced regeneration is induced + decrease in engine power and Active regeneration is try to start.Notify the driver that forced regeneration needs to be performed.
5. DPF soot level 120% or higher: Regeneration is not possible/must call for service to regenerate the DPF.

### **Cautions for handling the DPF assembly**

Please note the following while handling the DPF assembly.

1. The DOC + mixer weighs approximately 14 kg and the SDPF + SCR/AOC weighs 20 kg. Be careful not to drop them during removal.
2. When replacing the differential pressure sensor, take care to ensure that foreign matter does not enter the differential pressure sensor pipe. If foreign matter enters the pipe, a fault may occur due to a misreading of the differential pressure.
3. After removing the SDPF assembly, take care to prevent foreign matter from entering the inlet/outlet. If foreign matter enters the system, the catalyst may be damaged.
4. Since the differential pressure sensor and temperature sensor are installed on the outside of the assembly, be careful not to damage them during removal and installation.
5. Reusing a used gasket when disassembling the assembly may cause leaks, so make sure to use a new gasket.
6. Air leaks in the exhaust system can lead to violation of emissions regulations, increased noise, and increased exhaust smoke, so be sure to tighten parts to their specified tightening torque.





# Hydraulic System and Components



# Systems Operation, Description and Inspection

# Safety Instructions

---

## **WARNING**

---

### AVOID DEATH OR SERIOUS INJURY

Instructions are necessary before operating or servicing machine. Read and understand the Operation & Maintenance Manual and signs (decals) on machine. Follow warnings and instructions in the manuals when making repairs, adjustments or servicing. Check for correct function after adjustments repairs or service. Untrained operators and failure to follow instructions can cause death or serious injury.

---

# Table of Contents

## Systems Operation, Description and Inspection

Safety Instructions .....	206
Overview .....	208
Upper Structure 1 .....	208
Upper Structure 2 .....	209
Under carriage .....	210

# Overview

## Upper Structure 1

Figure 126

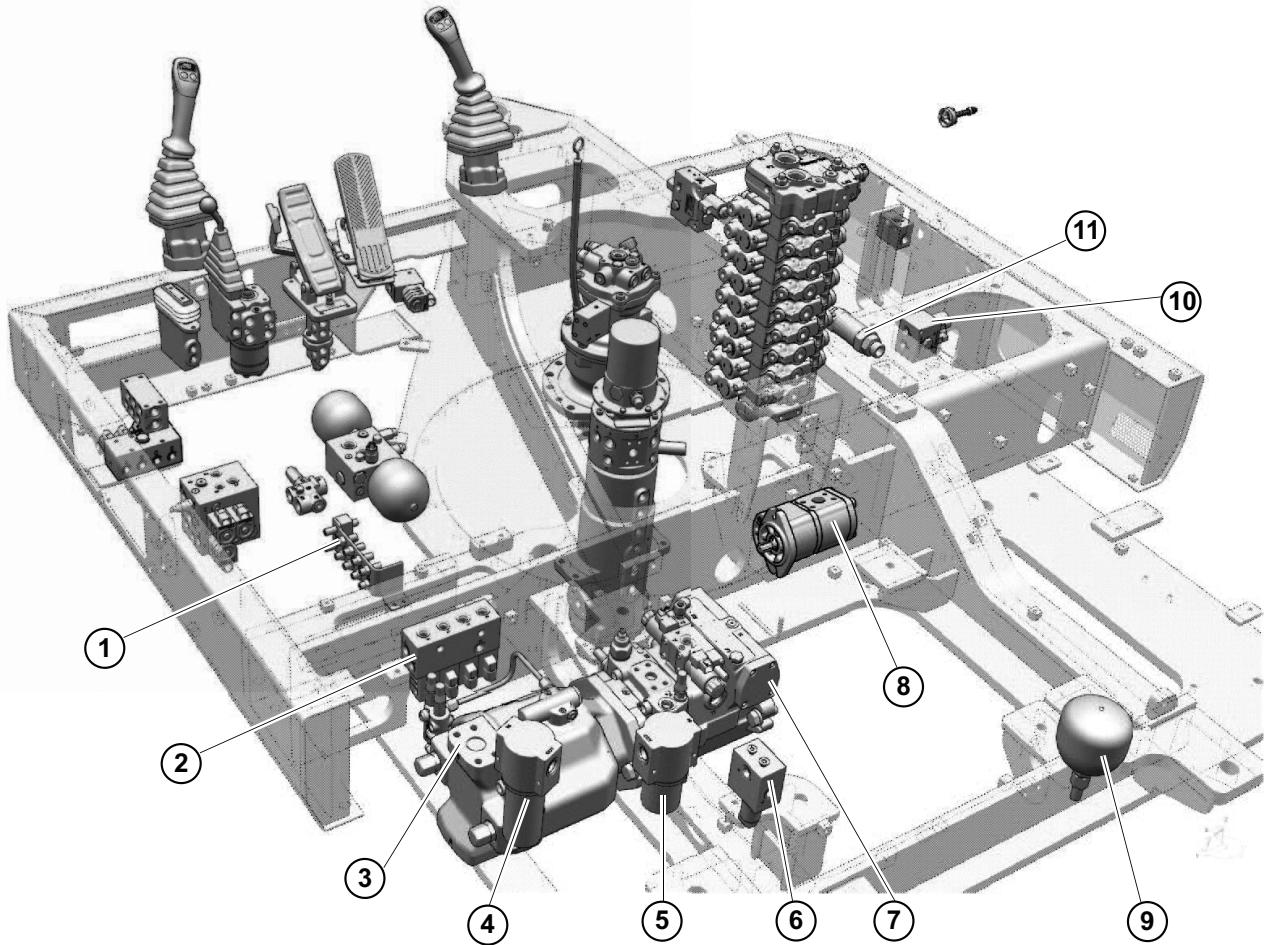

DS2105393

1	Joint plate	7	HST pump
2	Solenoid valve for F/R/HI/LO	8	Accumulator for pilot system
3	Main pump	9	Brake & steering pump
4	Brake filter	10	EPPR for rotating
5	Pilot filter	11	Bypass valve
6	EPPR for travel	-	-

# Upper Structure 2

Figure 127

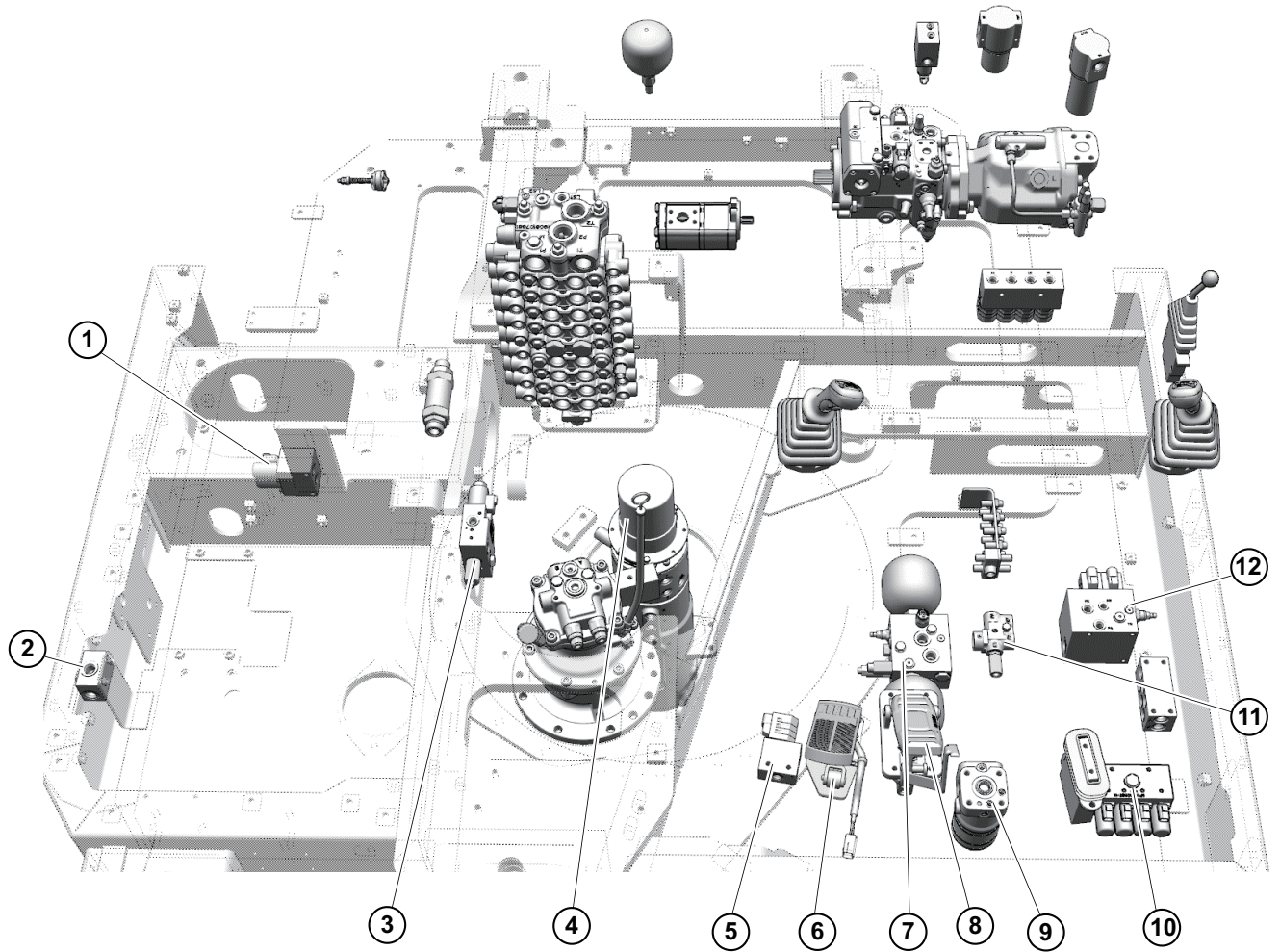

DS2105647

1	EPPR for rotating	7	Brake supply valve
2	Selection valve	8	Brake pedal valve
3	Quick hitch valve	9	Steering unit
4	Center joint	10	EPPR for one/two way & boom swing
5	Auto digging valve	11	Pilot valve
6	ACC pedal	12	Steering priority valve

## Under carriage

Figure 128

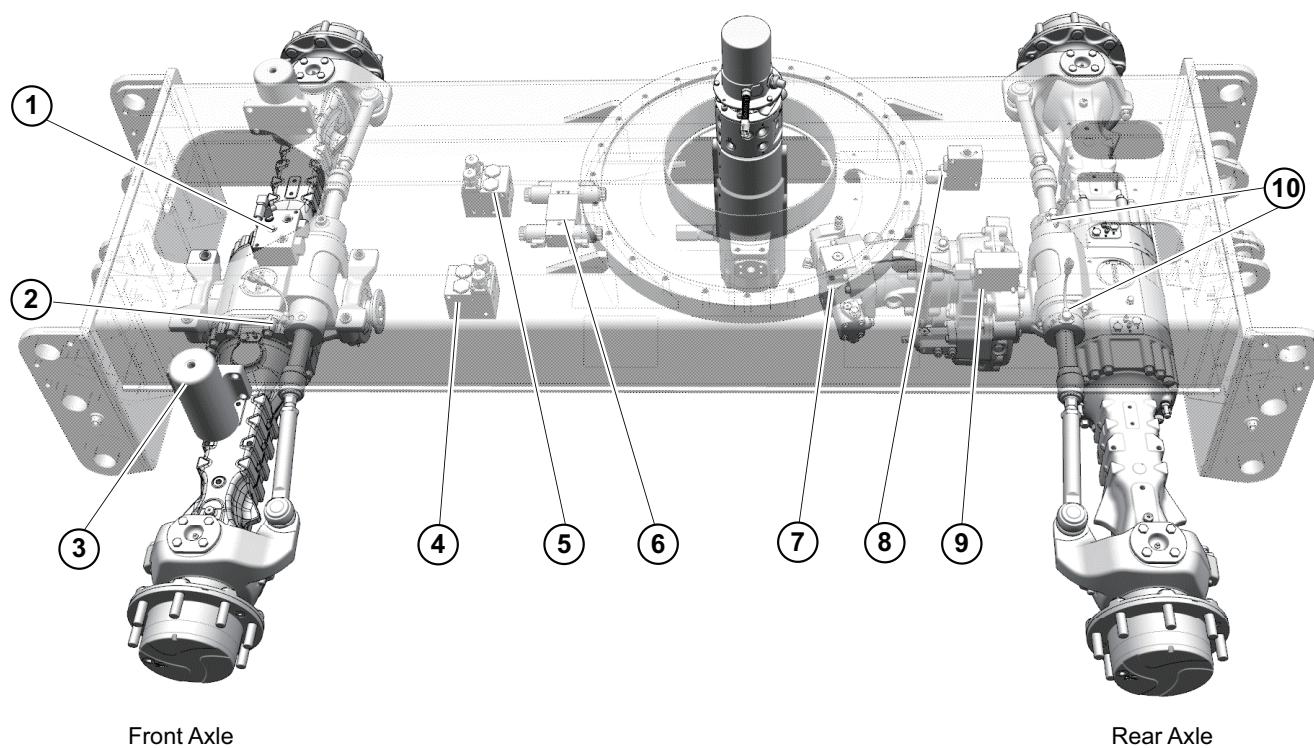

DS2105648

1	Chocking valve with shock-less valve	6	4 wheel steering valve
2	Positioning valve	7	HST motor with gear box
3	Ram / chocking cylinder valve	8	Trailer hitch valve
4	Front attachment (DZ of outrigger) valve	9	Relief valve block for trailer hitch
5	Rear attachment (DZ of outrigger) valve	10	Steering positioning sensor



# Components Operation, Description and Inspection

# Safety Instructions

---

## **WARNING**

---

### AVOID DEATH OR SERIOUS INJURY

Instructions are necessary before operating or servicing machine. Read and understand the Operation & Maintenance Manual and signs (decals) on machine. Follow warnings and instructions in the manuals when making repairs, adjustments or servicing. Check for correct function after adjustments repairs or service. Untrained operators and failure to follow instructions can cause death or serious injury.

---

# Table of Contents

## Components Operation, Description and Inspection

Safety Instructions .....	212
Main Pump .....	214
General Description. ....	214
Port information. ....	215
Theory of Operation. ....	218
Flow control. ....	219
Horsepower control. ....	220
Troubleshooting. ....	221
Main Control Valve .....	223
Circuit. ....	223
Section view - Neutral. ....	225
Section view - Shifting main spool. ....	225
Section view - Multi shifting of main spool. ....	225
Transmission .....	227
Overview - HST (Hydrostatic Transmission) .....	227
Layout. ....	228
HST pump. ....	228
Component detail. ....	229
Working principle. ....	232
HST motor. ....	238
Gear box. ....	239
Axle. ....	244
Pilot, Brake and Steering control system .....	247
Pilot system overview. ....	247
Steering system overview. ....	250
Brake system overview. ....	252

# Main Pump

## General Description

LS flow control system is one of flow discharging amount control system. The pump makes flow till specific required pressure of the actuator while machine operation. If the actuator does not meet required pressure by machine operation, the pump makes more oil flow and supply to actuator. The pressure will be increased till meet specific required pressure. The make minimize oil flow to maintain specific required pressure. The pump uses actuator pressure (Load Sensing pressure) for controlling discharging oil amount finally.

Figure 129

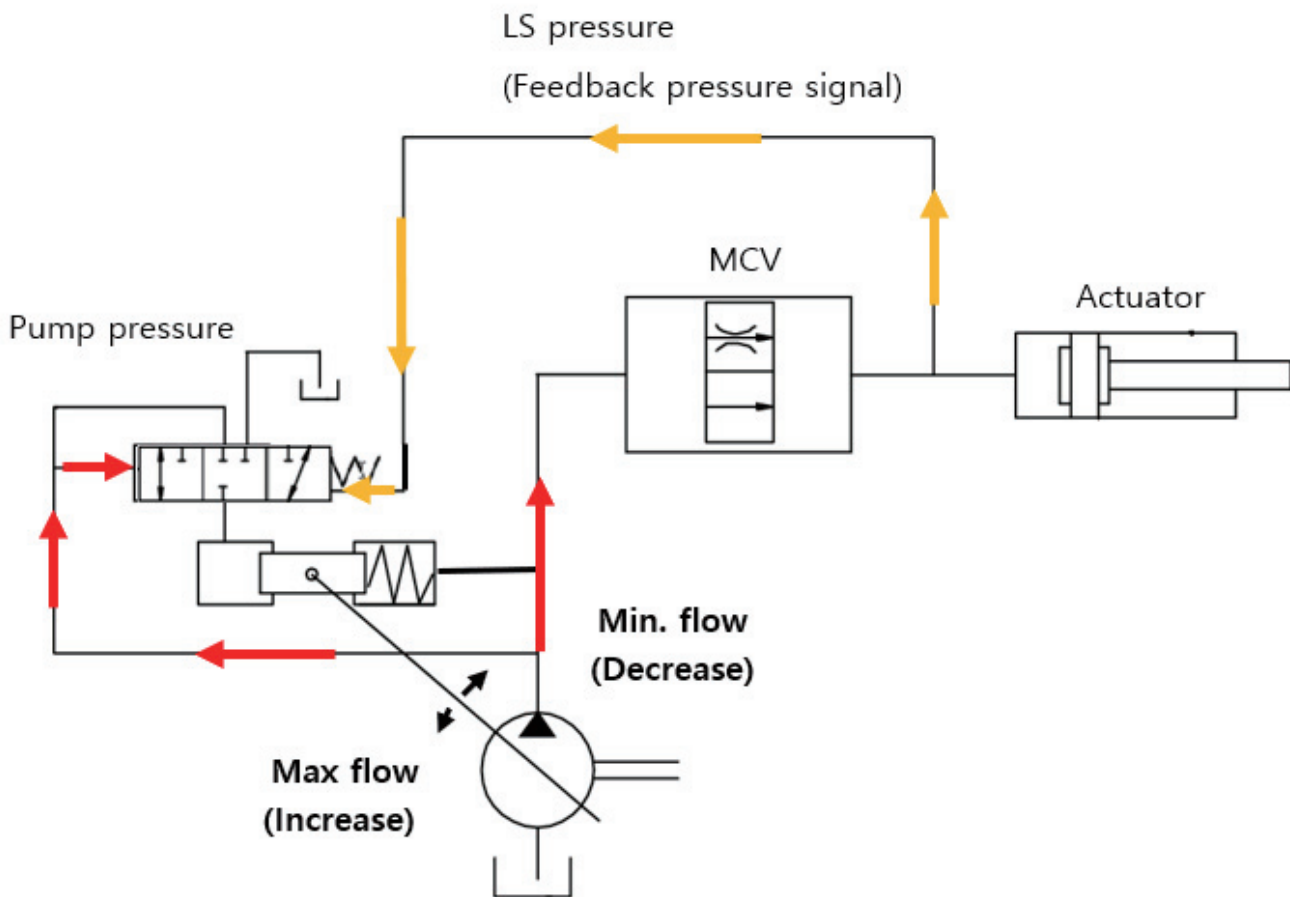

DS2105649

- The A10VO is an axial piston variable displacement pump with one axial piston rotary group for open - circuit hydrostatic drives.
- The flow is proportional to the drive speed and the displacement, By adjusting the angle of the swash plate in axis rotary groups, the one flows can be step-less changed.

- The A10VO Pump gets external flow control signal, internal horsepower and power shift control signal with pump it's pressure for controlling discharge flow amount.

## Port information

Figure 130

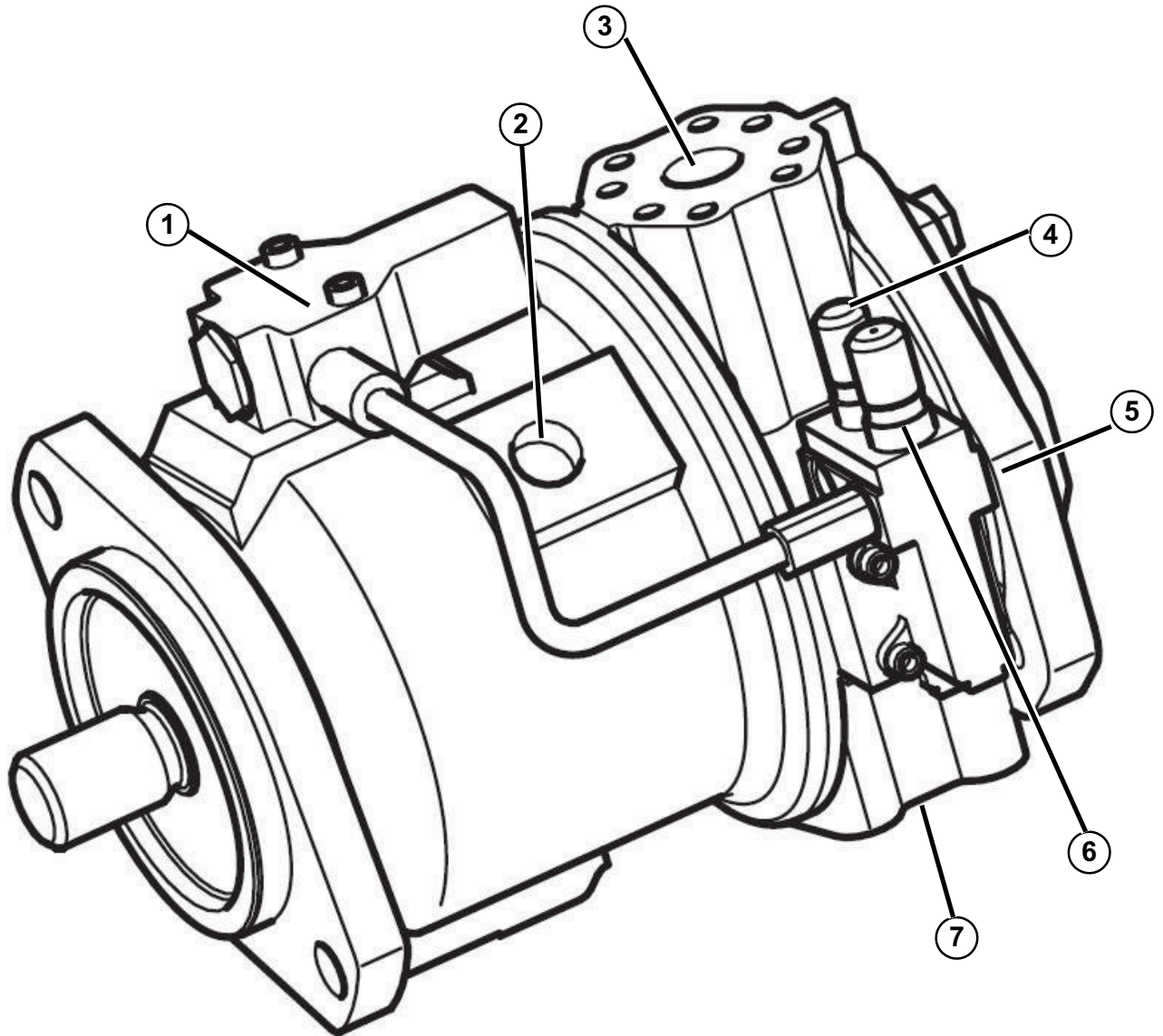

DS2105650

1	Power control valve (LR)	5	LS port
2	Drain port	6	Power control valve (DR)
3	Discharge port	7	Suction
4	Flow control valve (FR)	-	-

## **Port and Hydraulic Circuit**

Locations of ports for a suction, a delivery, a drain, a gauge, a pilot, etc. on the pump are shown and the locations of the ports can be seen in the following drawing. The symbols are the same as in the hydraulic circuit.

Figure 131

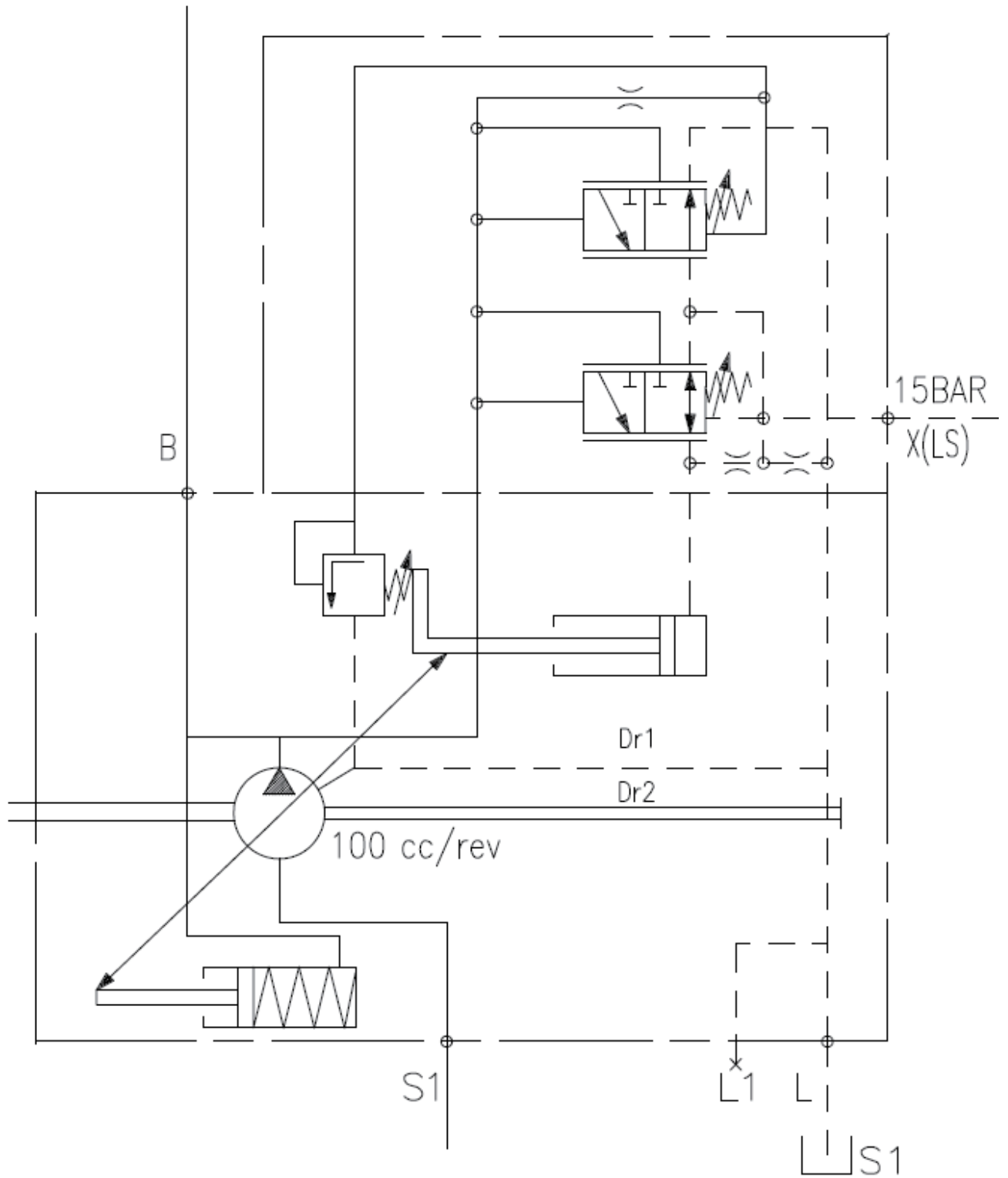

DS2105651

## Theory of Operation

Pump provides oil flow to an actuator through main control valve. A discharging flow amount is depended on 3 kinds of control signal as flow control, horsepower and power shift control. The flow control signal (LS signal) is coming from actuator, the pump uses it for determining supplying oil amount into the system. Horsepower signal is coming from pump its pressure and system pressure restricts supply oil amount finally. Power shift control restricts discharging oil amount with demanded machine operation condition by operator.

Figure 132

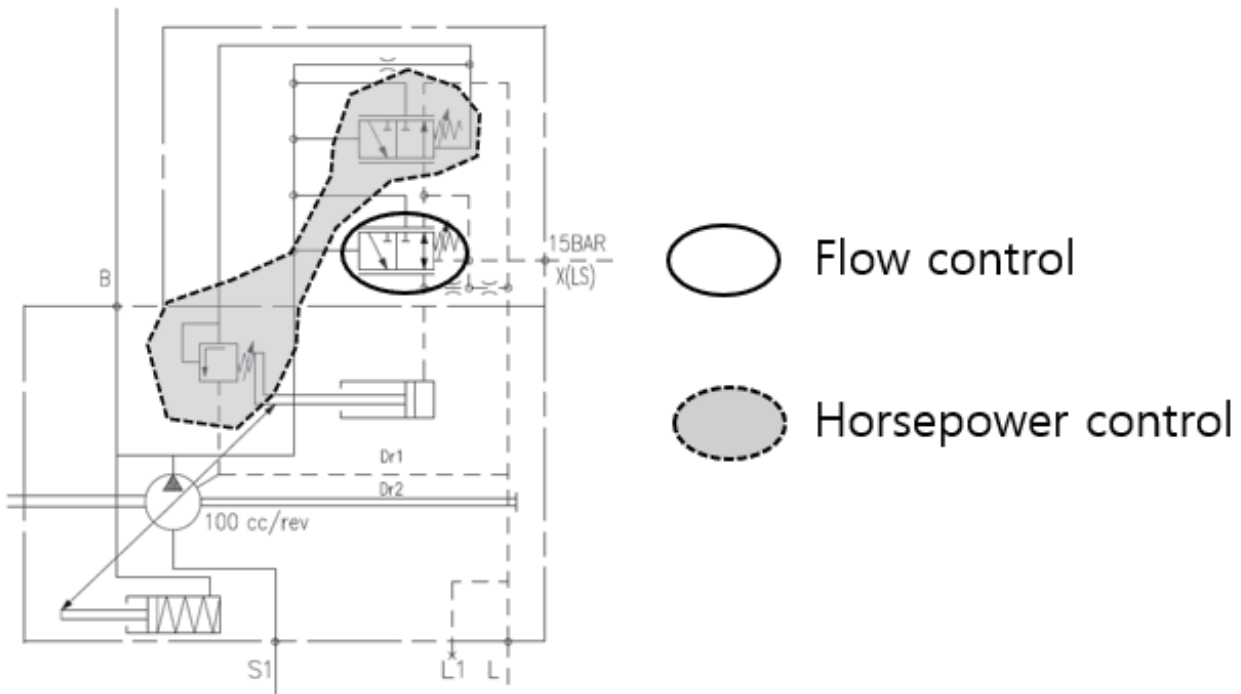

DS2105652

- Flow control (LS control signal): Get control signal from actuator (Cylinder/motor) through MCV. LS control signal is depended on machine operation and working load condition by operator demanding.
- Horsepower control: Get system pressure signal internally based on machine working condition (working load). Control and determine discharging oil amount as allowed engine power.
- Power shift control: Control and determine discharging oil amount as machine working condition by operator demanding under horsepower control condition.



# Flow control

Figure 133

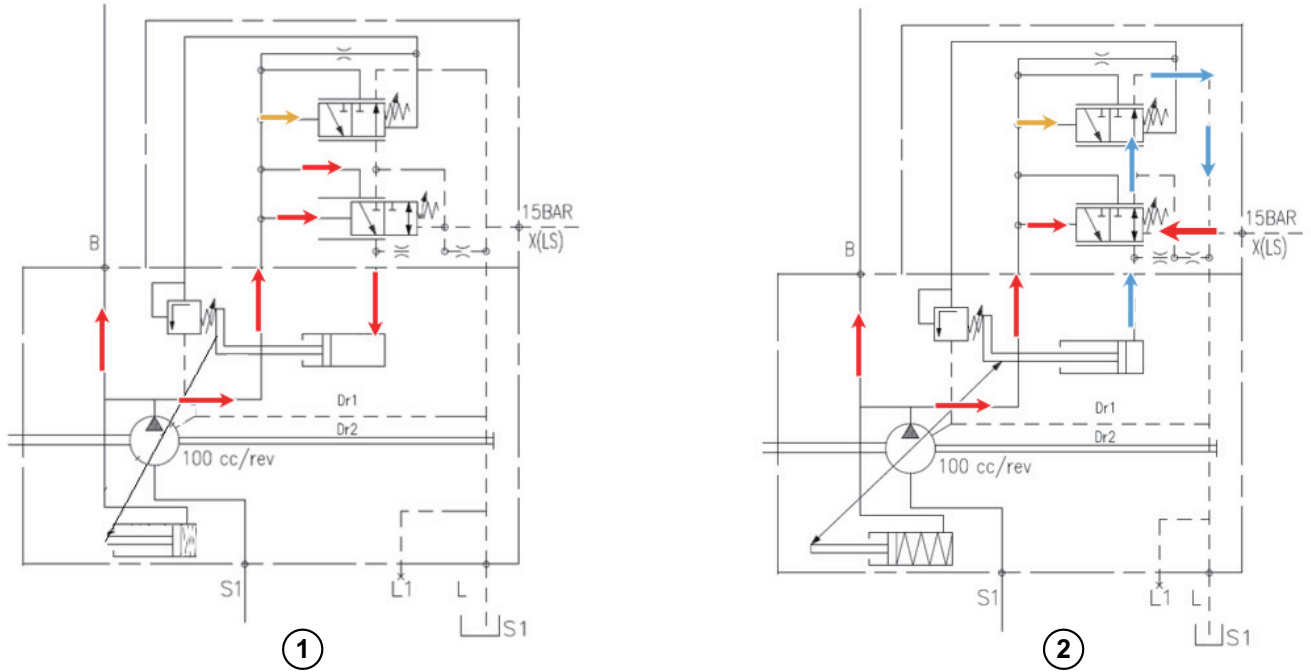

DS2105653

1	No LS signal (0 pressure) into pump from MCV: Oil flow decreased	2	High LS signal (high pressure) into pump from MCV: Oil flow increased
---	---	---	--

## Horsepower control

Horse power control pressure (signal) is built up by working load and a pump uses it's pressure for controlling discharge flow amount. In order not to drop an engine RPM while machine operation by overload from pump, the main pump is always controlling discharging oil flow.

- Low working load (Low main system pressure) on pump
  - More oil flow amount supply into system
  - Increase oil flow amount until not to drop engine RPM point as set RPM
- High working load (High main system pressure) on pump
  - Less oil flow amount supply into system
  - Decrease oil flow amount until maintain set engine RPM point

Power control valve (LR) and Power control valve (DR) works together for power control.

**Figure 134**

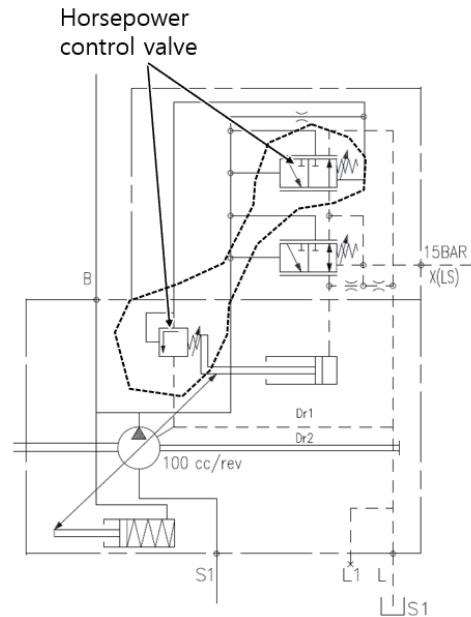

DS2105654

- High working load (High main system pressure) on pump with high flow control signal.
  - Reduce and Less oil flow amount supply into main system
  - Decrease oil flow amount until maintain set engine RPM

**Figure 135**

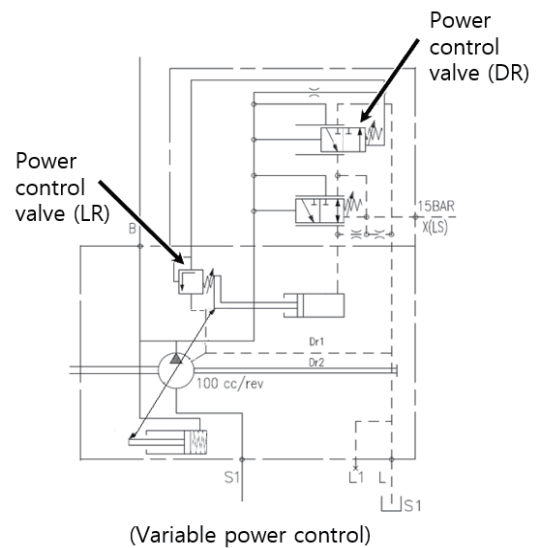

DS2105655

## Troubleshooting

### General Caution

This section describes the countermeasures to be taken if any abnormality is detected during the operation of pump.

General caution must be taken as follows:

1. Judge the nature of the abnormality before starting work.  
Determine if the problem in the circuit is caused by the regulator, attached valves, or pump.
2. Read and understand the maintenance manual before disassembling and follow the disassembling procedures.
3. When a section is disassembled, work in a clean area and do not allow dust or debris to enter the pump.
4. Since the parts are finely finished, handle them carefully to prevent damage.

### Check the Casing of the Pump for Abnormalities

The pump is often fitted with a regulator, accessory valves and associated pump. It can be difficult to find the cause of the failure. Investigate the following items, and the abnormal point will be revealed.

1. Check filter and drain oil. Check filters for excessive amounts of abnormal impurities. Since the shoes and cylinder may give off worn metal particles, a small quantity may be detected there. However if an excessive amount of metal particles is found in the filters, the shoes may be damaged. Similarly, check drain oil in the pump casing?
2. Existence of abnormal noises or vibrations. Check the pump for abnormal noises and vibrations. If any, investigate whether a noise is in the regular frequency, such as hunting of the regulator or the relief valve of an accessory valve. If it is an abnormal vibration or noise, it may be the result of cavitation or damage inside the pump.
3. Case in which two pumps are used. For the circuit with two single pumps or motors or for the duplex pump, exchange the piping of one pump with that of the other one. With the results of this exchange, it will be determined if the trouble is the problem of the circuit downstream from the pump or not.
4. Pressure measurement at various points. If the failure is in a casing, do not unnecessarily open the pump to check, but measure pressures at various areas to investigate the abnormal position.

## Abnormal Noises and Abnormal Vibrations

No.	Possible Cause	Remedy	Remark
1	Cavitation	Prevent cavitation? Check working oil for emulsion.	1. Low boost press? 2. Failure of the associated pump? 3. Air inflow through the suction pipe? 4. Increased suction resistance.
2	Damage in the swaging (caulking suction) of the shoe.	Replace the piston, shoe, shoe plate, etc.	-
3	Damage of the cylinder block.	Replace the cylinder block.	-
4	Wrong installation of the pump.	Correct installation.	-
5	Hunting of the regulator.	Repair the regulator.	See the instruction manual for the regulator.
6	Hunting of the relief valve of the accessory valve.	Repair the accessory valve.	See the instruction manual for the accessory valve.

# Main Control Valve

## Circuit

Figure 136

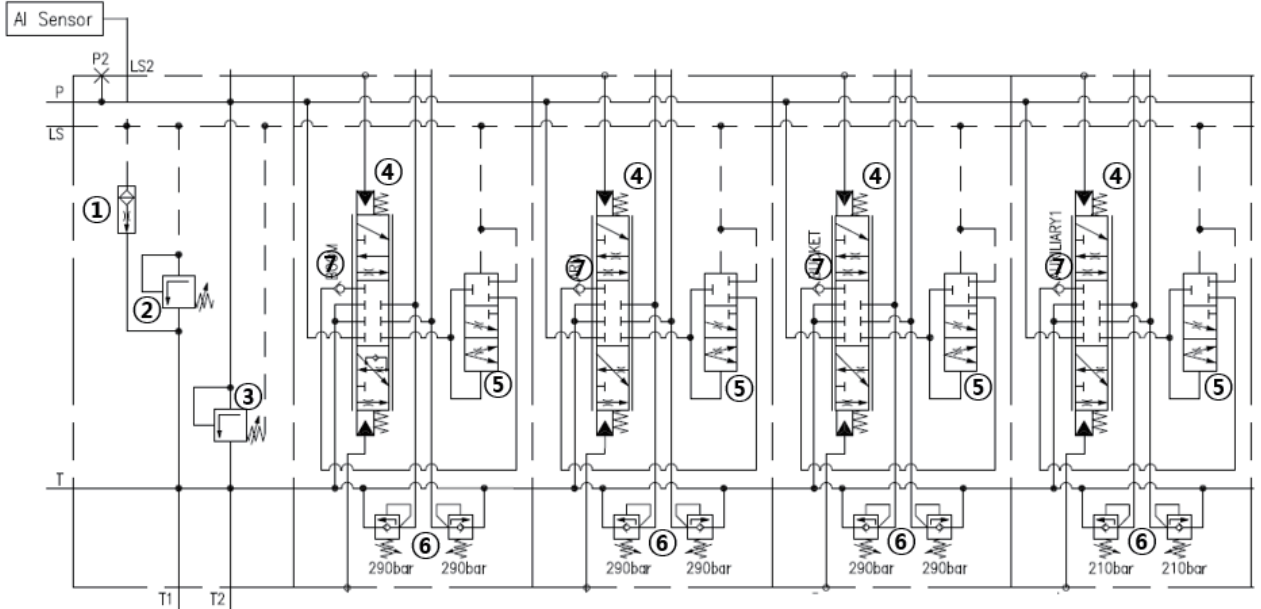

DS2105656

1	LS flow control valve (LS drain valve)	5	Compensator
2	LS relief valve	6	Port relief valve (Overload relief valve)
3	Adjustment unit (Flushing valve)	7	Load holding valve (Load check valve)
4	Main spool	-	-

In let block has P, T and LS port and several number of valves are three, all of in, return and LS oil path is connected on each element block. LS flow control valve (LS drain valve), LS relief valve and adjusting unit (Flushing valve) is on the inlet block. Each element block has main spool, compensator, load holding valve (load check valve) and port relief valve (Overload relief valve).

Overview (port)

Figure 137

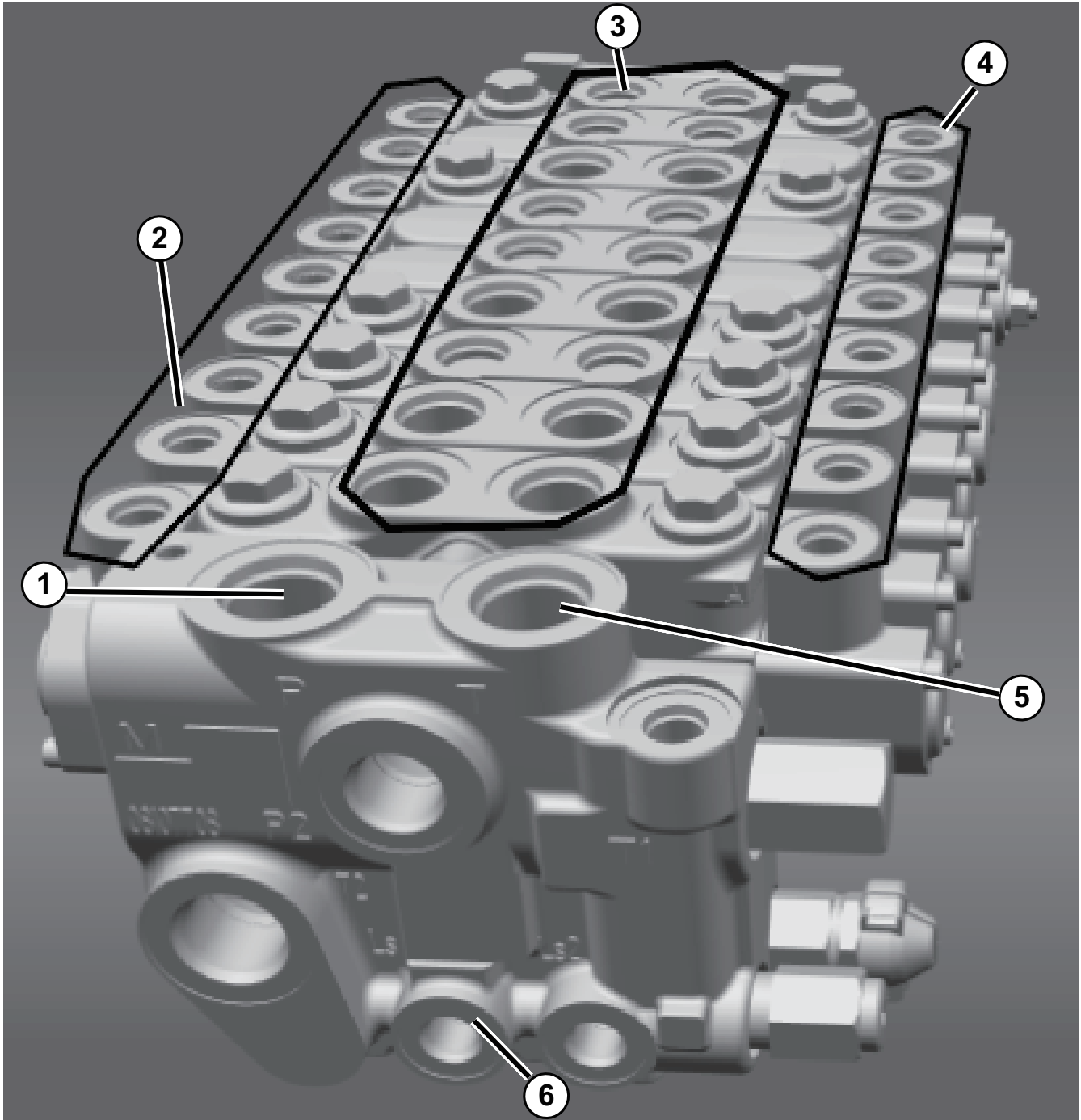

DS2105657

1	P port	4	Pilot control signal port
2	Pilot control signal port	5	T port
3	Actuator port	6	LS port

### Section view - Neutral

Stand by pressure of P oil path is clogged by main spool and the P oil flow dose not reach on compensator.

Figure 138

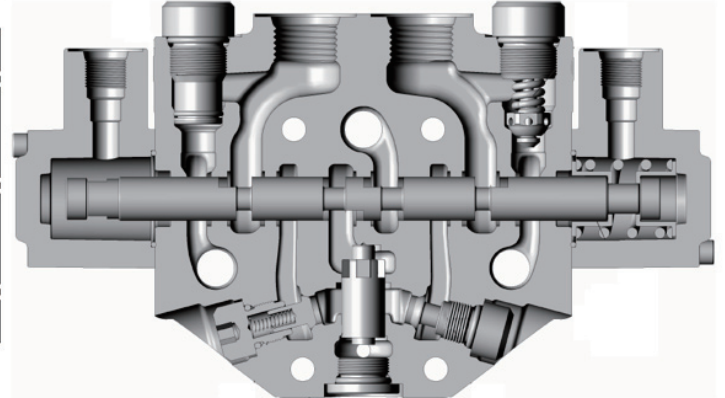
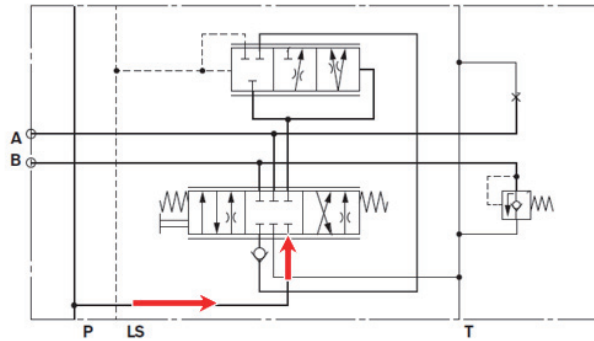

DS2105658

### Section view - Shifting main spool

When main spool is shifted, P oil flow goes to compensator. The compensator is shifted for connecting oil flow to the load holding valve through main spool for supply oil flow to an actuator finally. LS signal also come out to LS port through compensator as well.

Figure 139

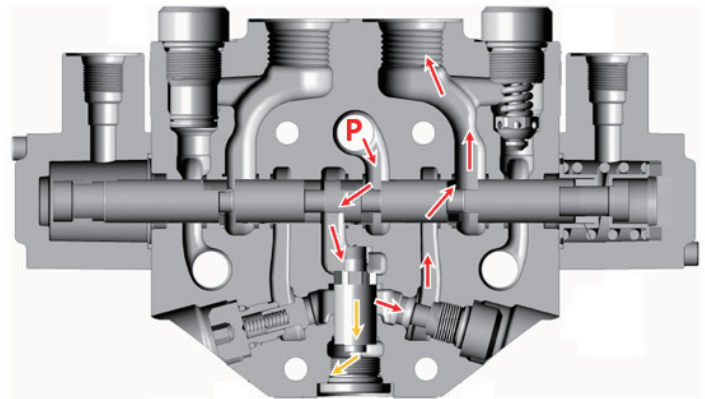
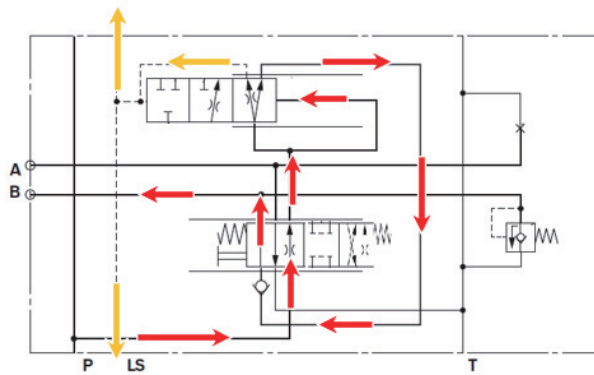

DS2105659

### Section view - Multi shifting of main spool

Compensator is lifted up by LS pressure of highest working condition for clogging P oil path on the valve block. High pressure of LS pressure is transferred into all of each compensator and the high LS pressure makes oil path of supply oil with low load restrict by each compensator. A compensator makes oil flowing into high load actuator from a low load actuator for combined machine operation. Discharged oil flow from pump transfers to all of actuator even high or low load operation.

Figure 140

Highest load operation

Low load operation

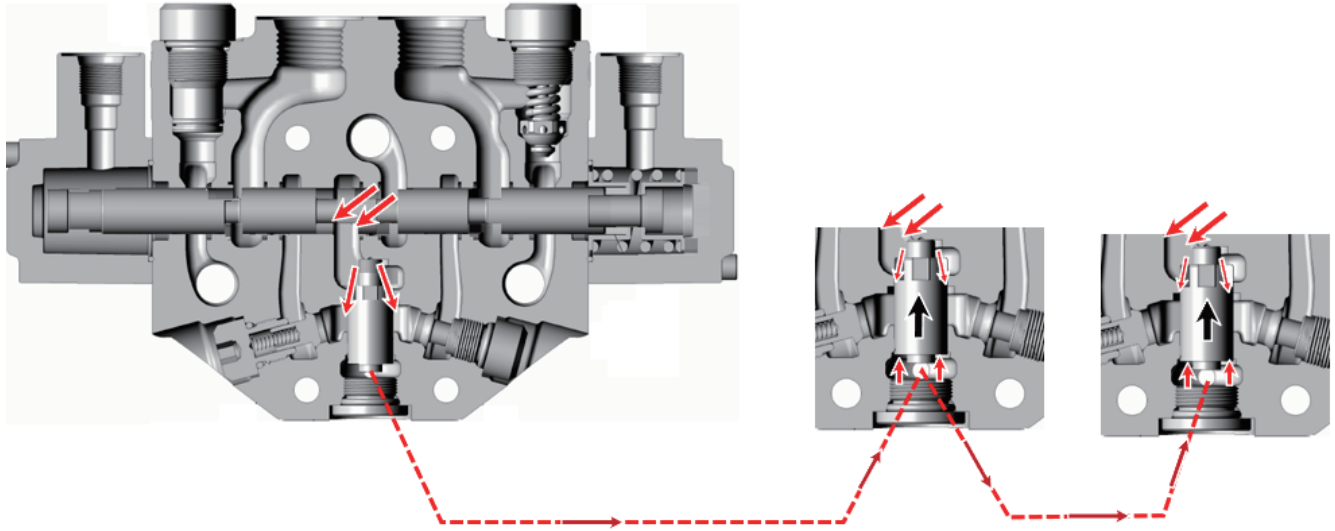

DS2105660



# Transmission

## Overview - HST (Hydrostatic Transmission)

- Closed circuit of traveling system
- Engine power transfers to hydraulic pump and the dynamic power of the engine is connected to axle indirect with hydraulic fluid through components.
- The pump provides oil flow to the travel motor on a transmission or gearbox for machine traveling.
- Variable traveling speed is provided by traveling load condition without any shifting shock.
- Extend service brake life due to hydraulic brake performing

**Figure 141**

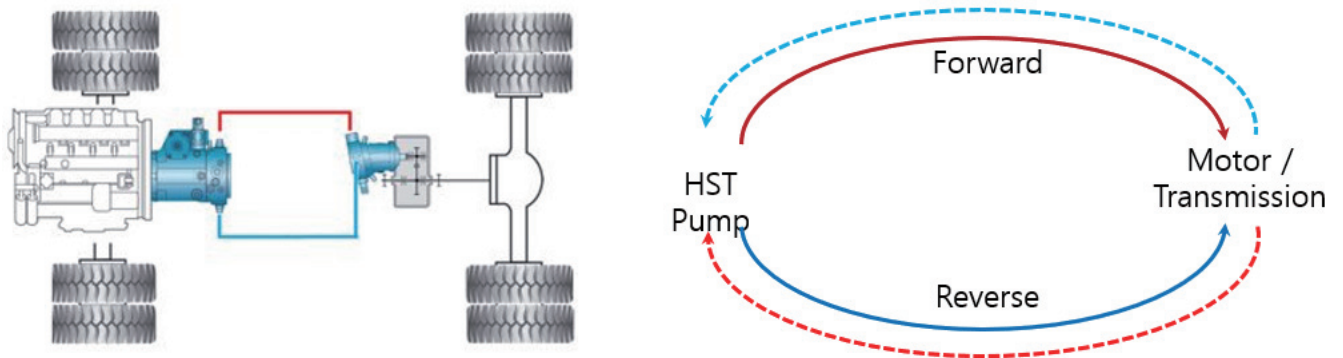

DS2105661

HST system is closed loop circuit hydraulic system. The oil is circulated in the in the system circuit only. (pump > motor > pump)

HST Pump: Provide oil flow into the system with different amount flow and direction by control signal as operator demanding.

HST motor: Get oil flow from pump and transfer rotating force and direction. The output force and speed is controlled by motor itself or control signal as well.

## Layout

HST pump provides bi-direction of oil flow to a travel motor. Discharging flow amount for traveling is controlled by traveling load or operator demanding. The motor makes two rotating direction like forward and reverse traveling by pump discharging flow direction. It performs variable traveling speed and traveling power with its motor and gearbox depends on traveling condition.

Figure 142

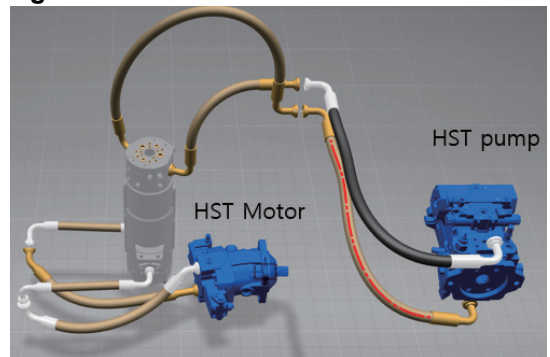

DS2105662

Figure 143

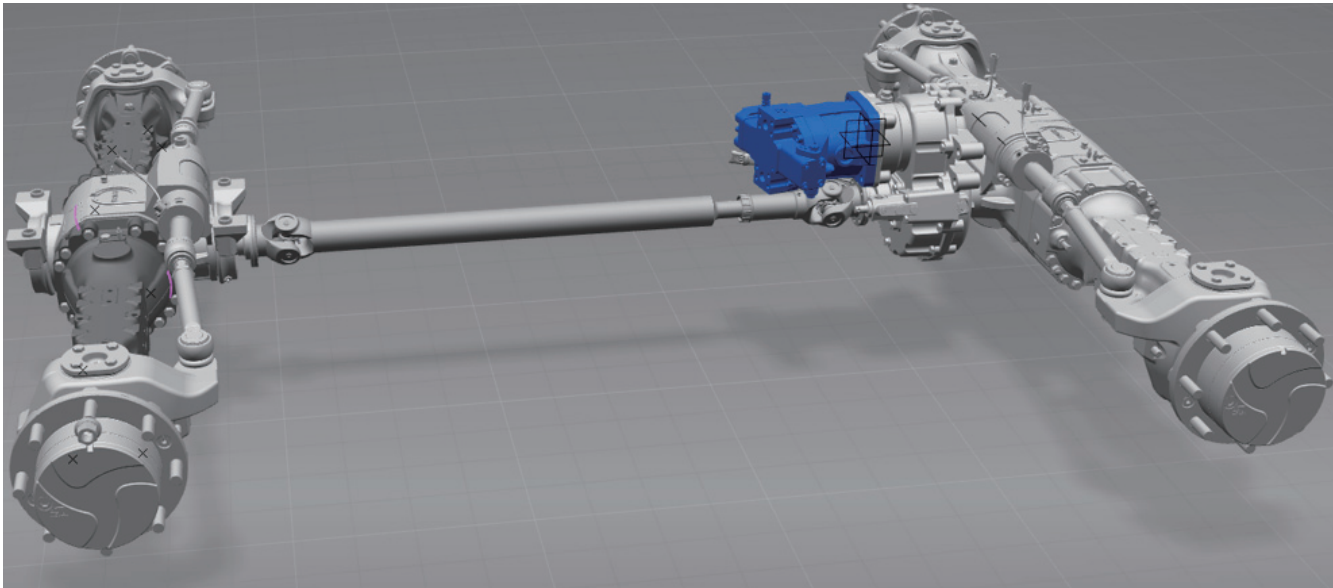

DS2105663

Traveling power from HST motor transfers to gearbox, drive shaft and front/rear axle finally. Possible to use 100% of pump performance transferring to the motor (Less energy loss) and perform traveling retarding or braking by hydraulic flow control. Front and rear axle has wheel steering performing as rounding and crap walk.

## HST pump

Variable displacement piston pump with bi-directional flow discharged by electro-hydraulic control signal.

Figure 144

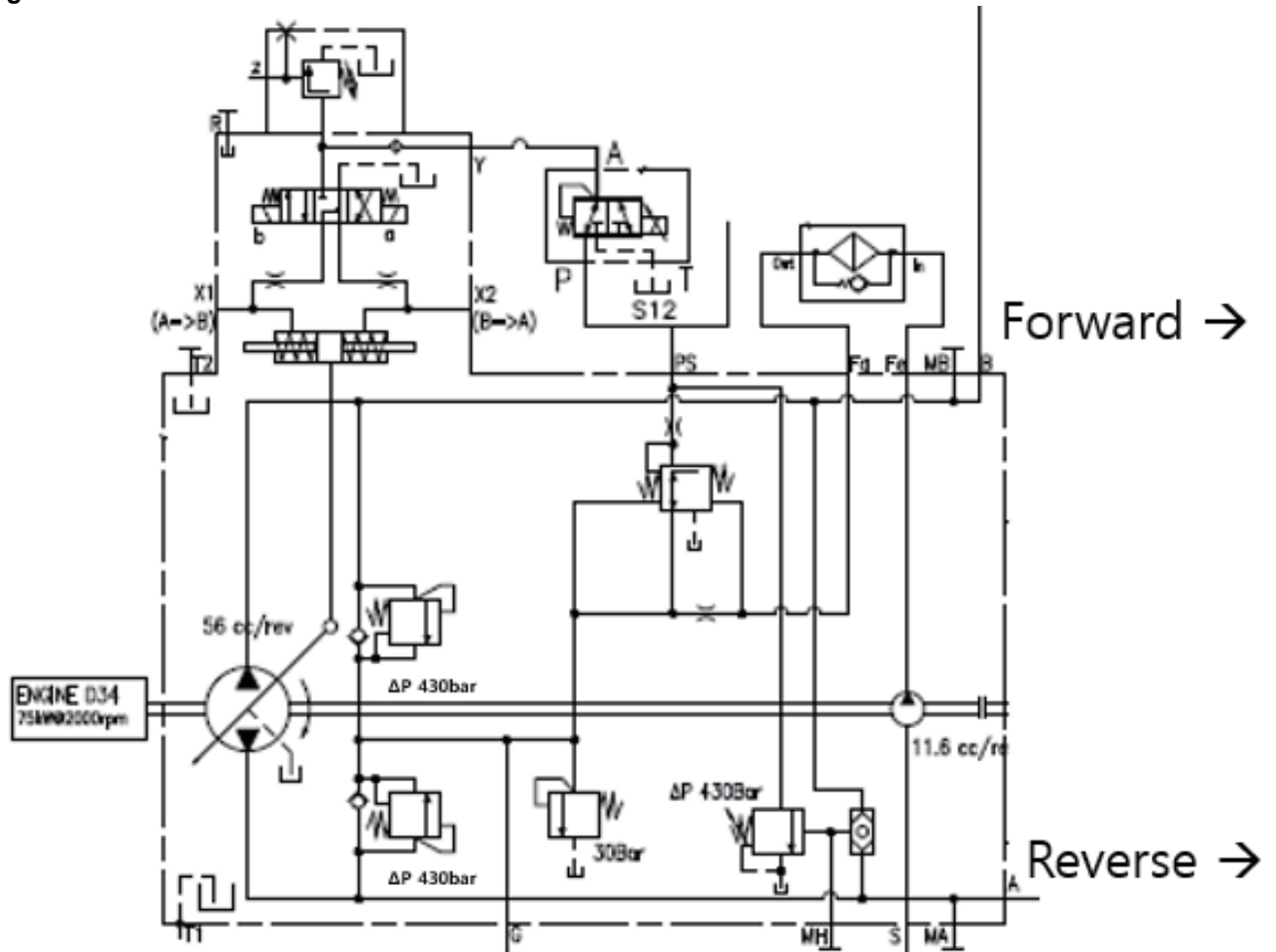

DS2105664

- Forward: B Port --> A Port
- Reverse: A Port --> B Port

### Component detail

#### Directional valve

The directional valve provides a pressure into directional piston chamber for machine traveling direction. (Forward or reverse)  
 The directional spool is shifted by solenoid valve. Controlled pressure from travel control proportional valve and modulated 2ndly pressure is transferred into directional piston chamber for making traveling flow.

Figure 145

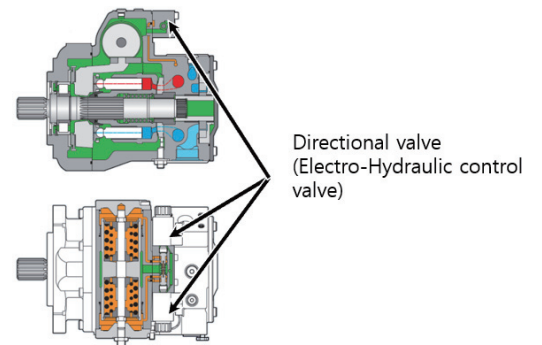

DS2105665

## Boost pump

The pump is internal gear pump, it supply oil to internal HST system for make up oil flow with flushing oil through motor continuously. And supply oil for controlling direction piston through travel control proportional valve, system charging and pilot system as well. The discharging flow amount and pressure is depended on rotation speed of the pump.

Figure 146

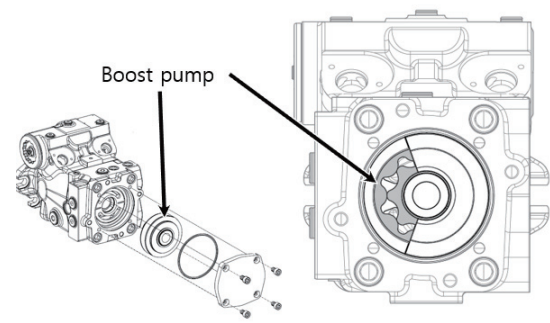

DS2105666

## Control pressure modulation valve

Control Pressure Modulation Valve is providing source pressure into Directional control Piston through Electro-Hydraulic control valve. The providing source pressure is depended on pump rotating speed (Same as Engine RPM). It senses boost pressure and set final source pressure. If high engine RPM, high source pressure is into direction piston chamber, it makes high traveling performance. But low source pressure by reduced engine RPM with engine load, reduce traveling performance by this valve controlling. This valve controls source pressure of directional control piston depends on engine load.

Figure 147

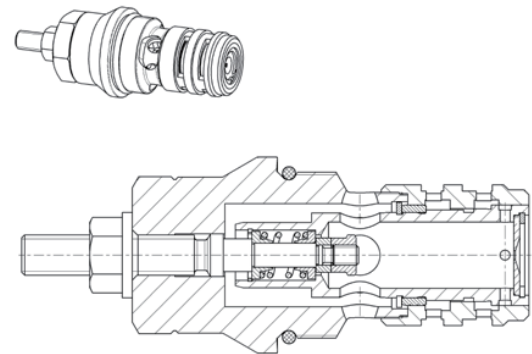

DS2105677

## Cut off relief valve

Cut off relief valve restricts maximum traveling system pressure. When system pressure of traveling is reached on specific value like 430 bar, the source pressure into directional control piston is controlled by this cut off valve. Controlled source pressure by cut off relief valve transfers into directional control piston with approx. 20bar with high engine RPM. So, traveling maximum pressure is restricted with pump discharging oil flow amount by controlled pressure.

Figure 148

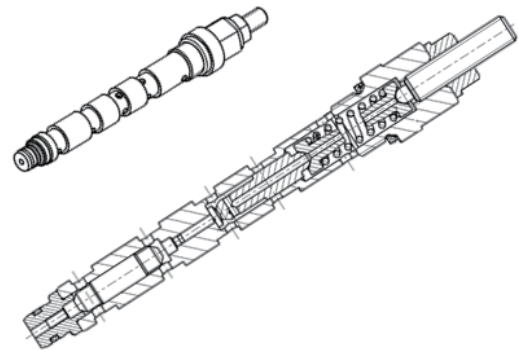

DS2105678

### Boost pressure relief valve

Boost pressure relief valve is one of pressure reducing valve and makes maintaining specific value of the pressure. It provides make up oil into the HST system and supplies oil into the machine pilot system. When neutral condition of the traveling, charged oil is filled both side of travel oil line, so the pressure of both line is maintained with 30 bar all the time when engine is running. Neutral position: pressure of both travel line is 30 bar. Traveling: Out put pressure for traveling is high and return pressure is 30 bar.

Figure 149

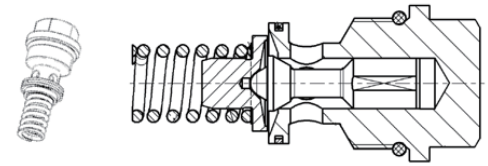

DS2105679

### Inching valve

When operator depresses service brake pedal, the brake pressure make source pressure of directional proportional valve (Electro-hydraulic control valve) connect to tank. It means that the pressure into directional piston chamber is proportion pressure by brake pressure. No more machine is traveling without source pressure of directional piston chamber through directional proportional valve (Electro-hydraulic control valve).

Figure 150

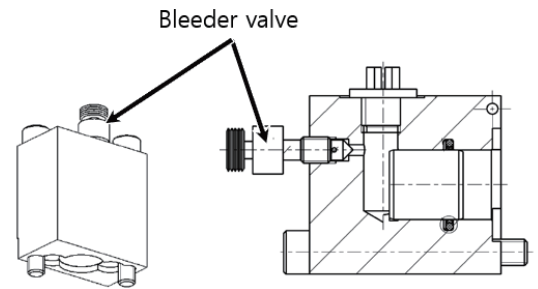

DS2105680

## Working principle

### Neutral position

Figure 151

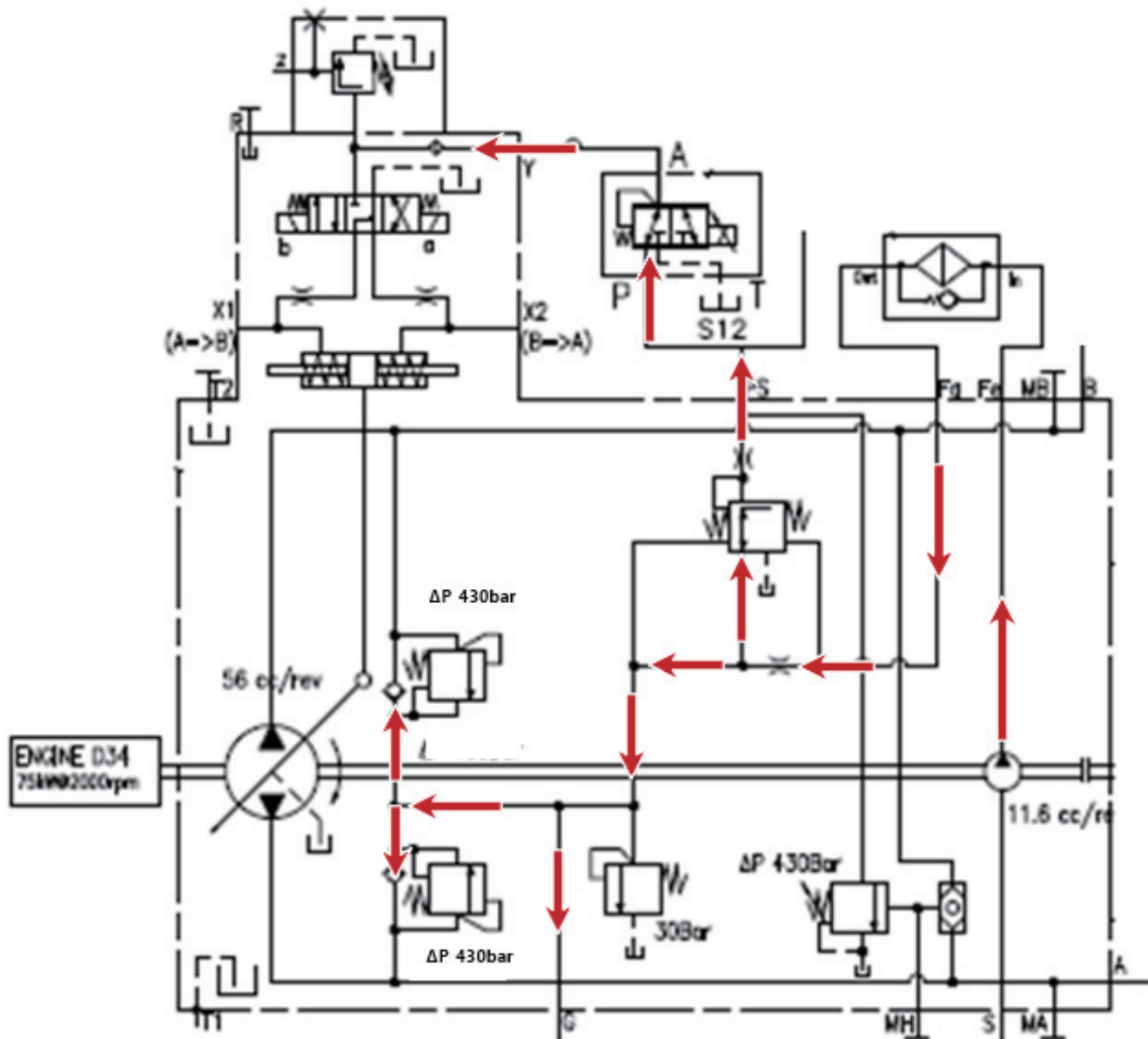

DS2105681

When engine is running, boost pump is charging flow for all system line. The charged flow goes to control pressure modulation valve, boost pressure relief valve through and machine pilot system through pilot filter. The oil is supply to pilot system of the machine, make up for traveling main line and Electro-Hydraulic control valve. Source pressure of Electro-Hydraulic control valve is depended on boost pump rotating speed.

Traveling  
Figure 152

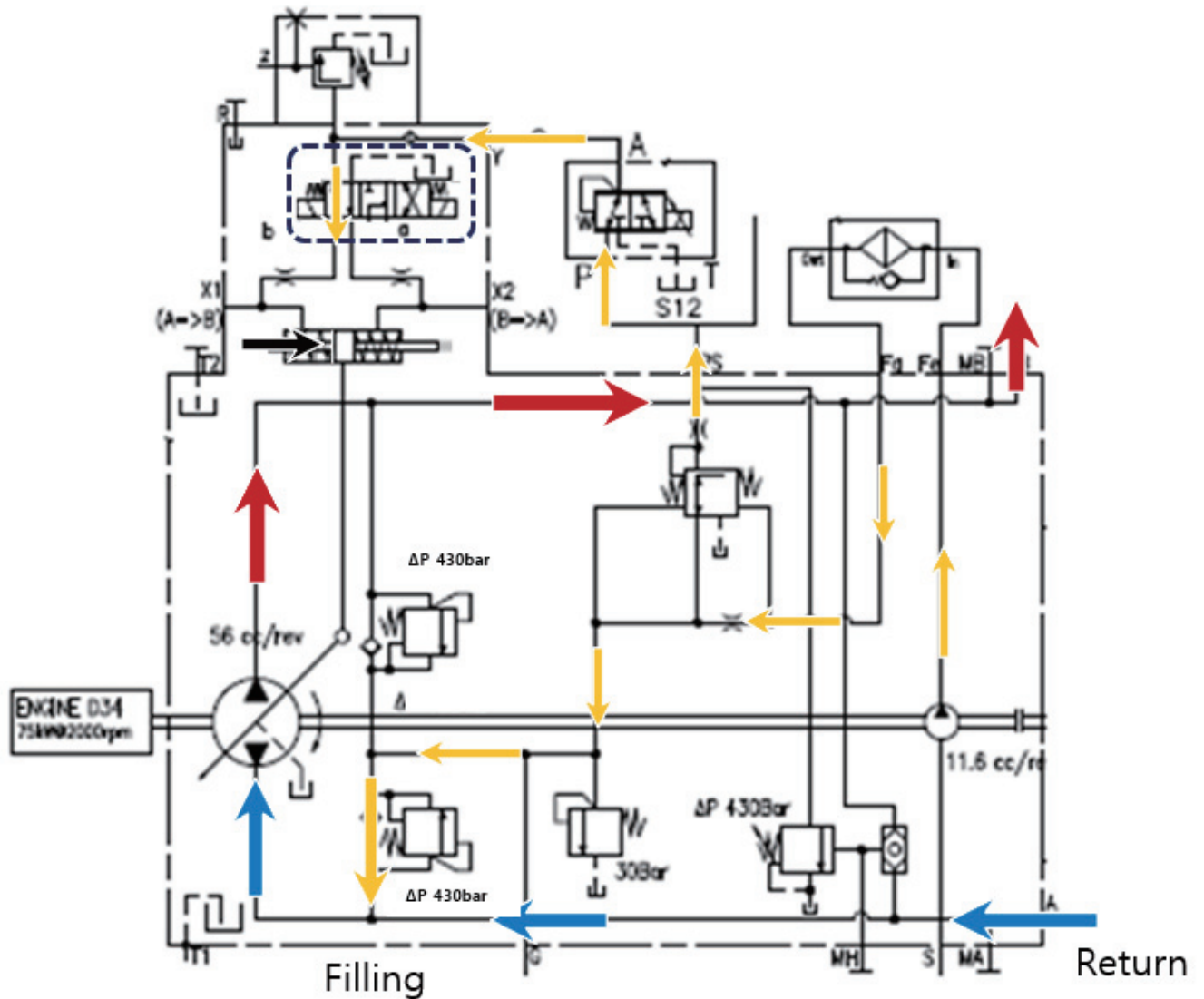

DS2105682

When machine travel, Elector-Hydraulic control valve is shift and the directional piston is shifted by operator demanding. Swash plate on rotary part moves for discharging oil flow for traveling. After circulate oil through travel motor the oil back to pump again, but some of flow amount goes to tank with separate drain oil line on travel motor. Oil from boost pump is continuously charged into traveling system line as for filling of flushed oil amount through the travel motor and system protection against cavitation.

Figure 153

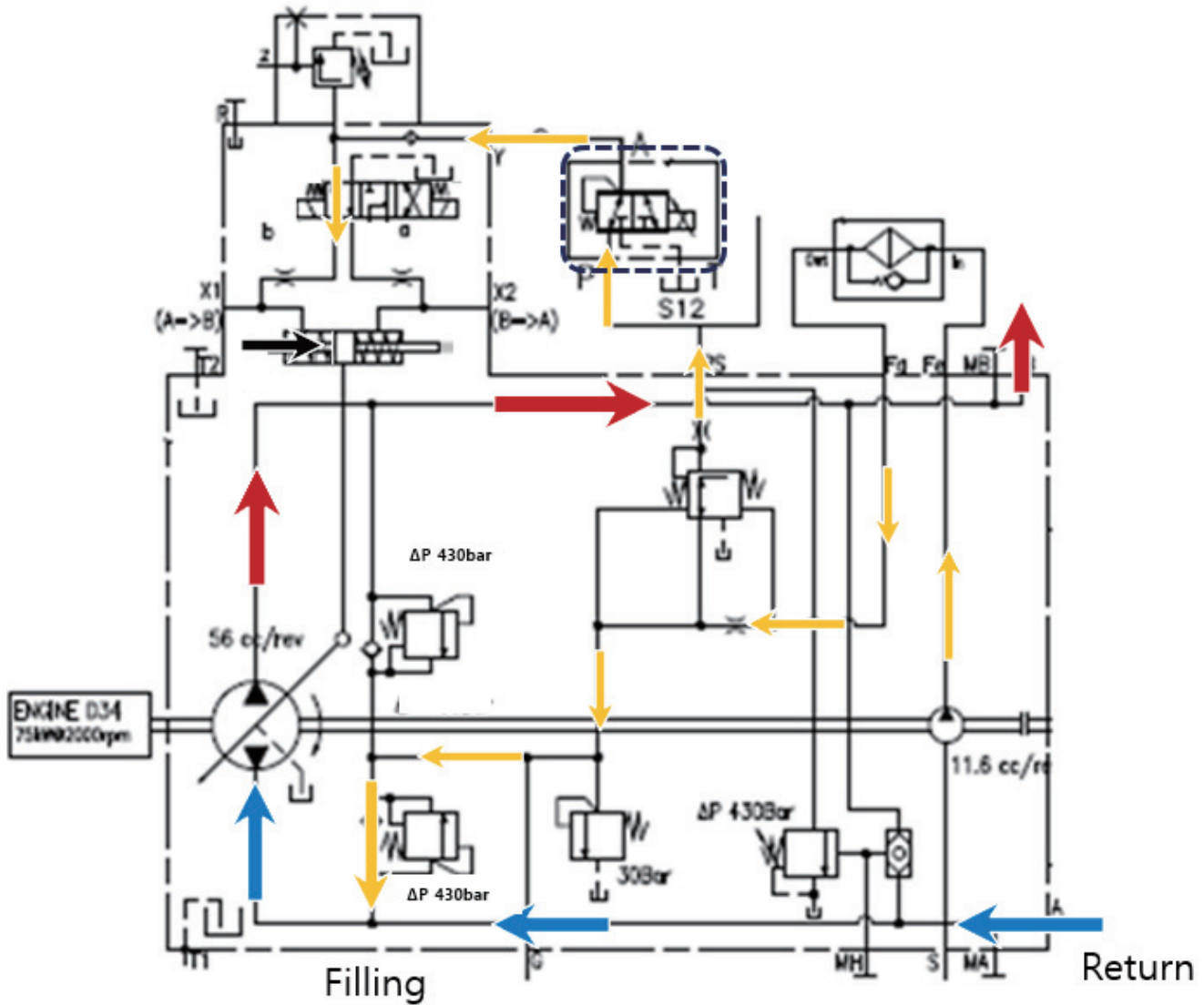

DS2105683

There is one Travel Control Proportional valve for traveling which place before Electro-Hydraulic control valve. It works by accelerator position. This Travel Control Proportional valve controls source pressure of Electro-Hydraulic control valve individually regardless pump's torque control or speed. Even if high engine RPM with front attachment working condition, it could provide variable traveling performance with variable proportional control for different traveling speed. (Even high pump speed, it controls low machine speed)



Travel overload  
 Figure 154

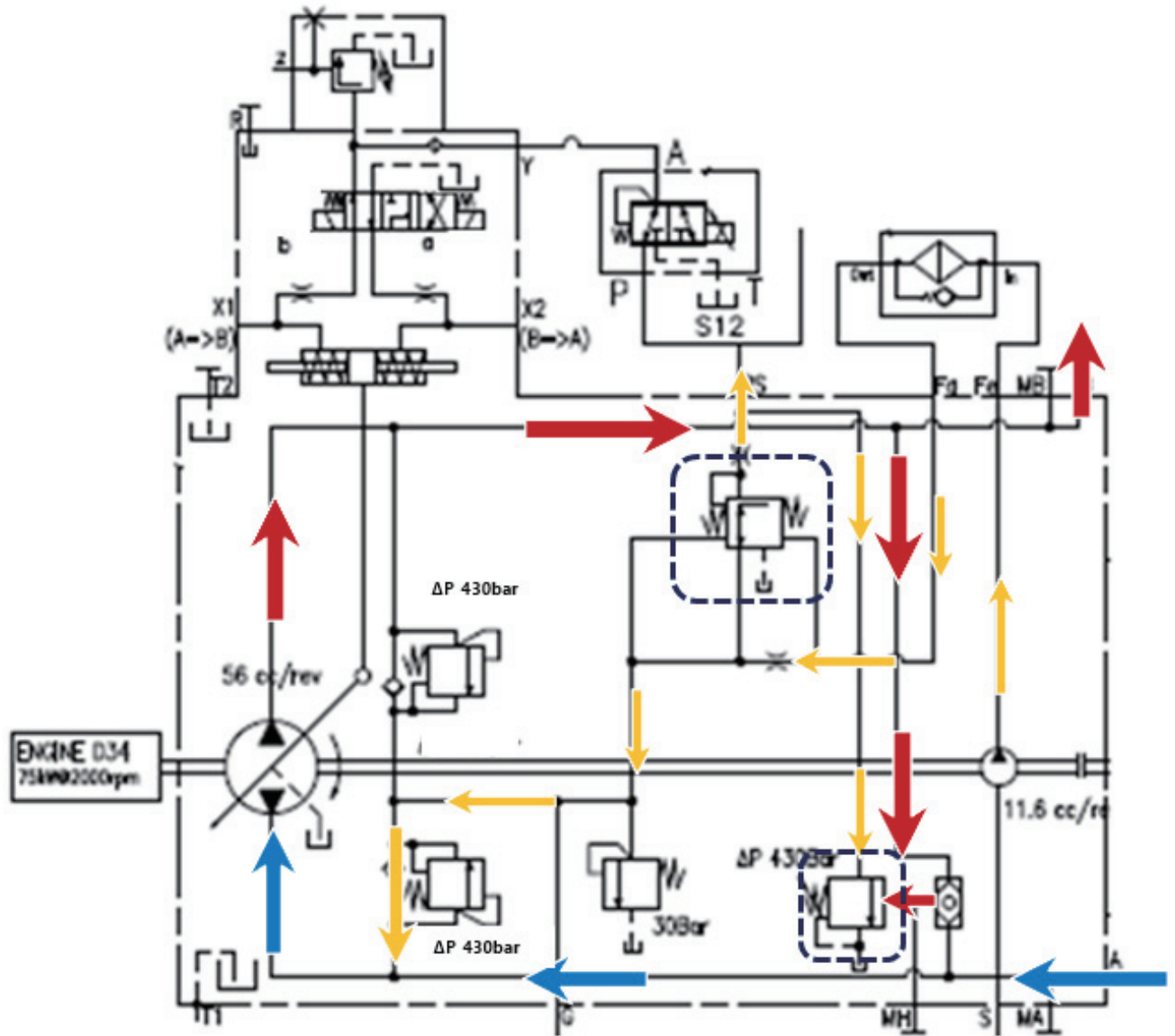

DS2105684

When machine travels with overload condition like over 430bar of traveling system pressure. Traveling performance is reduced by controlled source pressure into direction piston through Electro-Hydraulic control valve and direction chamber. The 430bar relief valve does not make oil flow for Electro- Hydraulic control valve even traveling demanding by operator.(No more oil goes to direction piston chamber)

Torque control

Figure 155

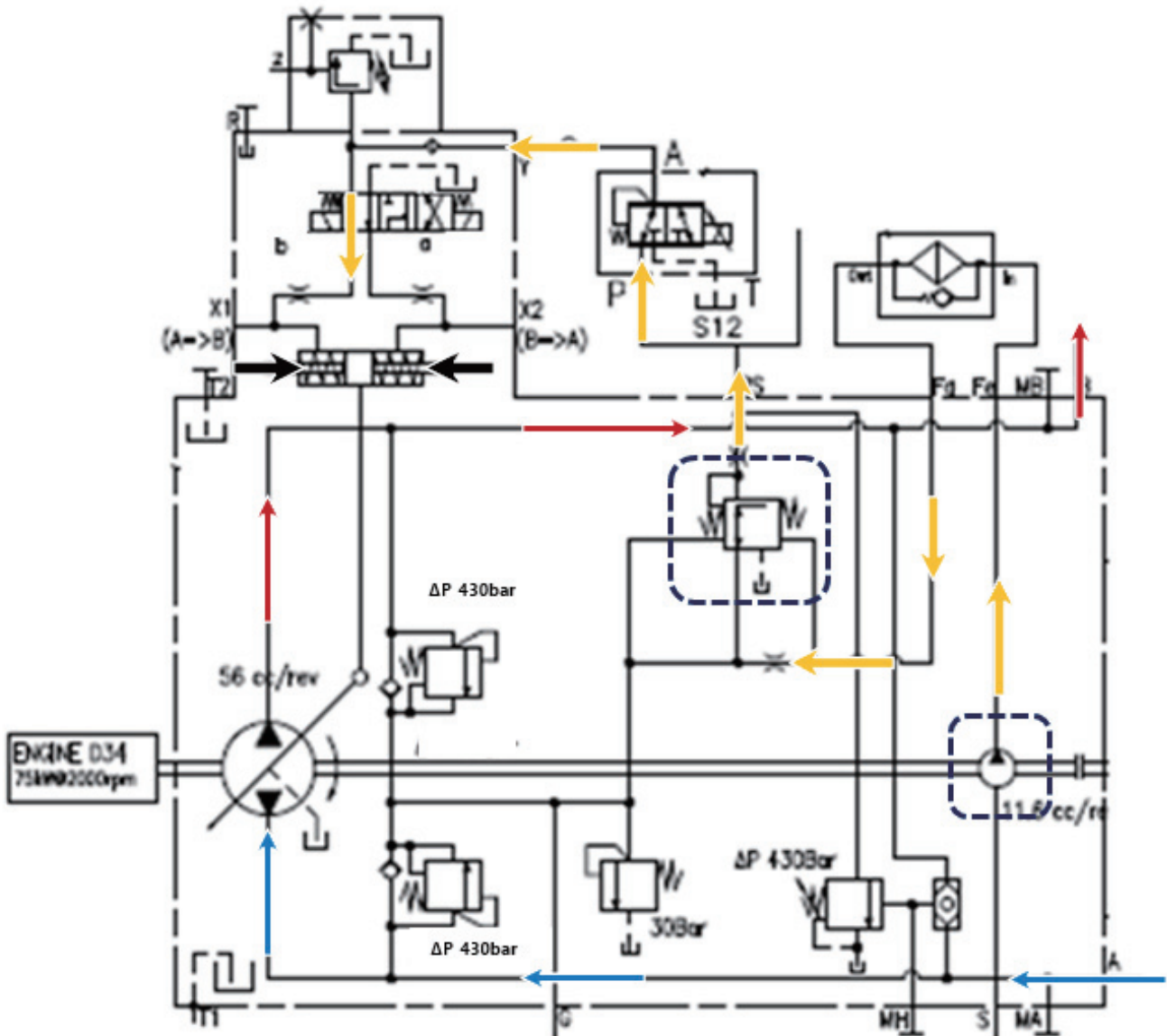

DS2105685

While machine traveling, the machine gets traveling load variable and continuous, at that time engine RPM is also drop or changed. Discharging flow/pressure from boost pump is relative with engine (Pump) RPM. When engine RPM drops as traveling load, source pressure of into direction piston through Electro-Hydraulic control valve is also dropped by boost pump discharging flow. Traveling performance is reduced by reduced source pressure on direction piston. And dropped engine RPM is recovered with reduced discharging flow amount.

Inching travel  
 Figure 156

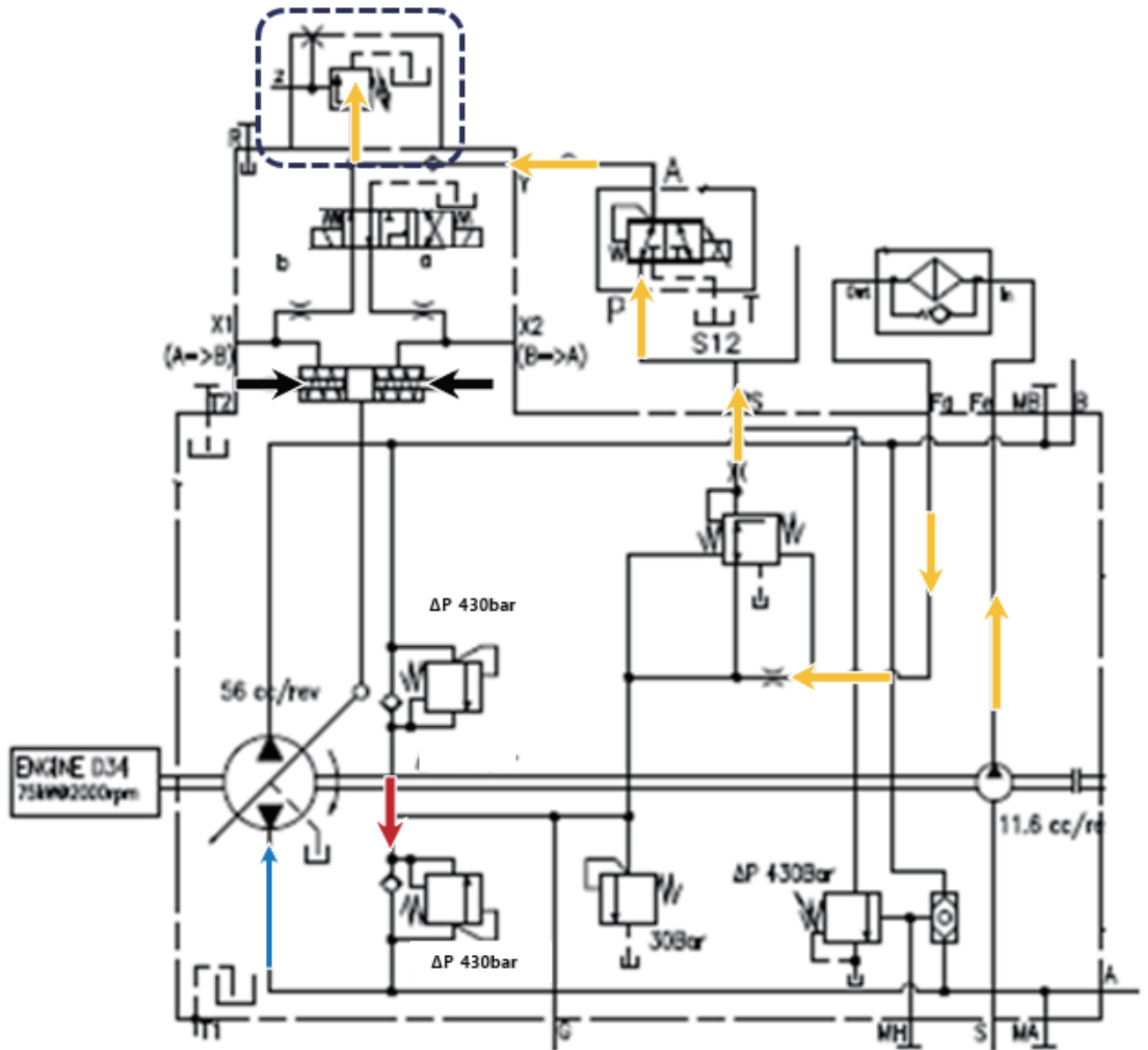

DS2105686

When operator depresses brake pedal, the inching valve is shifted and connecting source pressure of direction piston through Electro-Hydraulic control valve to the tank line. The inching pressure for inching traveling is depended on brake pressure of brake pedal.

# HST motor

## Overview

Figure 157

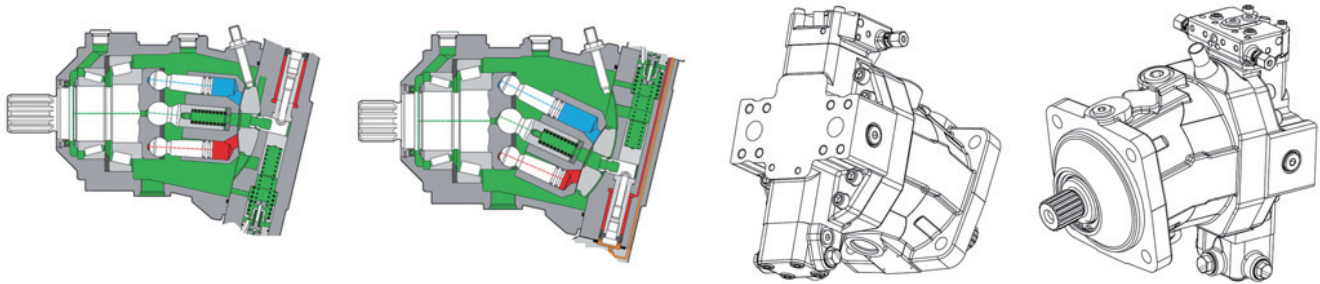

DS2105688

The output speed of the motor is proportional to the inward flow and inversely proportional to the displacement of the hydraulic motor. Torque is same. The swivel angle of the bent-axis rotary group is step-less variable. With two-point control, the swivel angle can be switched from maximum to minimum angle. The motor has small drain oil flow which call it flushing. The flushing flow is used to remove heat from the hydraulic circuit and boost flow is charged system as much as flushing oil amount.

## Port

Figure 158

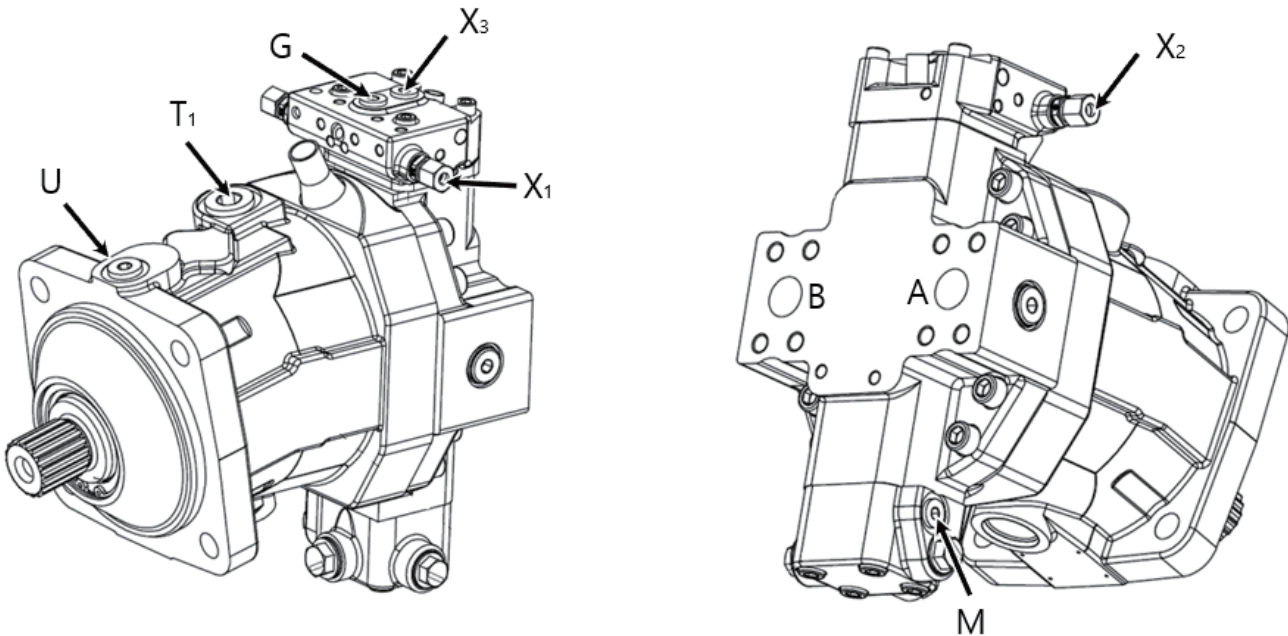

DS2105689

G	Synchronized pressure check port	T1	Tank
X1	Pilot signal (reverse)	U	Bearing flushing
X2	Pilot signal (forward)	M	Positioning spool (Large chamber) pressure

X3	Pilot signal (torque control spool)	-	-
----	-------------------------------------	---	---

## Gear box

### Overview

Figure 159

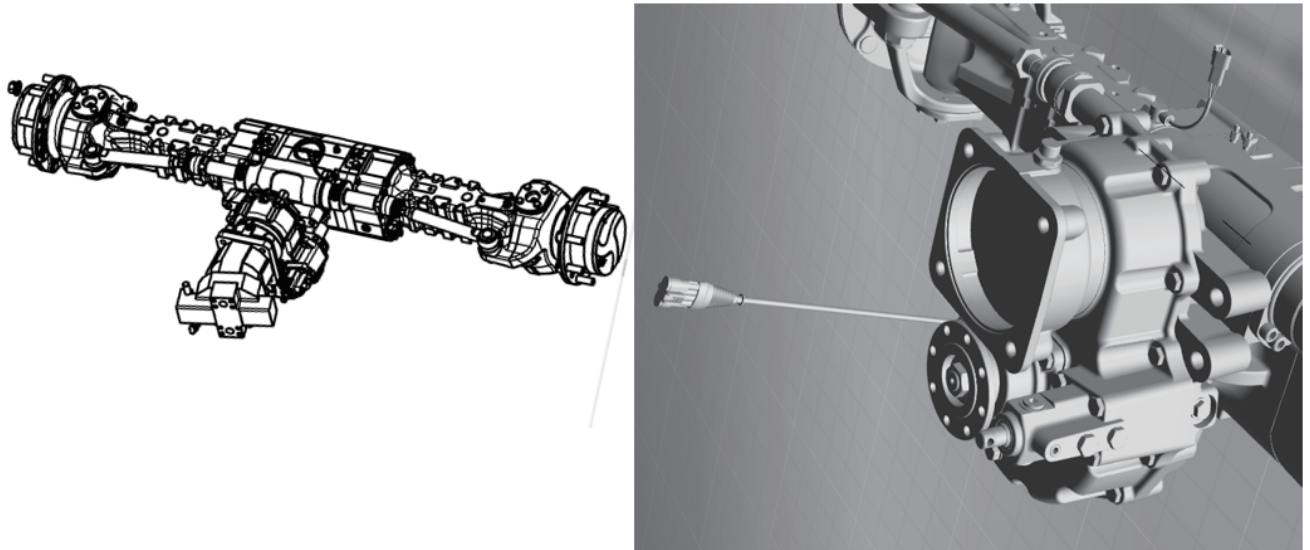

DS2105690

Gear box is mounted on rear axle and it provides two different output speed with internal gear set, and the gear set is engaged mechanically by mechanical shifting lever which is controlled by pilot pressure. Speed sensor monitors machine traveling speed to recognize traveling or stopping for shifting gear.

Figure 160

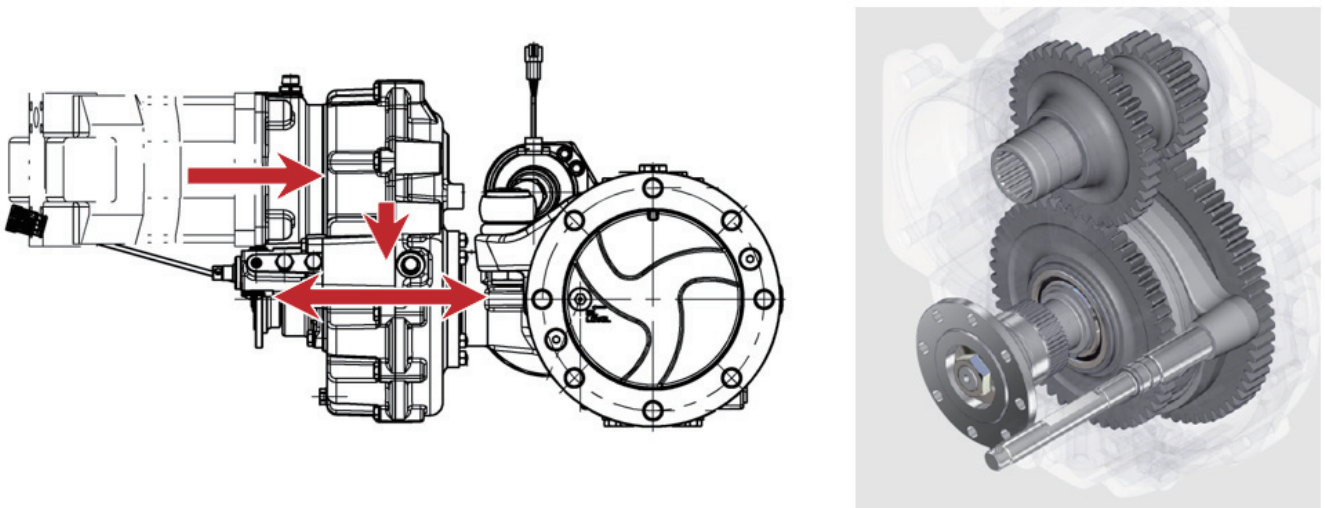

DS2105691

The output power is transferred to front axle through output flange on the gear box, same output power is transferred on front and rear axle from travel motor.

G	Synchronized pressure check port	T1	Tank
X1	Pilot signal (reverse)	U	Bearing flushing
X2	Pilot signal (forward)	M	Positioning spool (Large chamber) pressure
X3	Pilot signal (torque control spool)	-	-

**Detail**

**Figure 161**

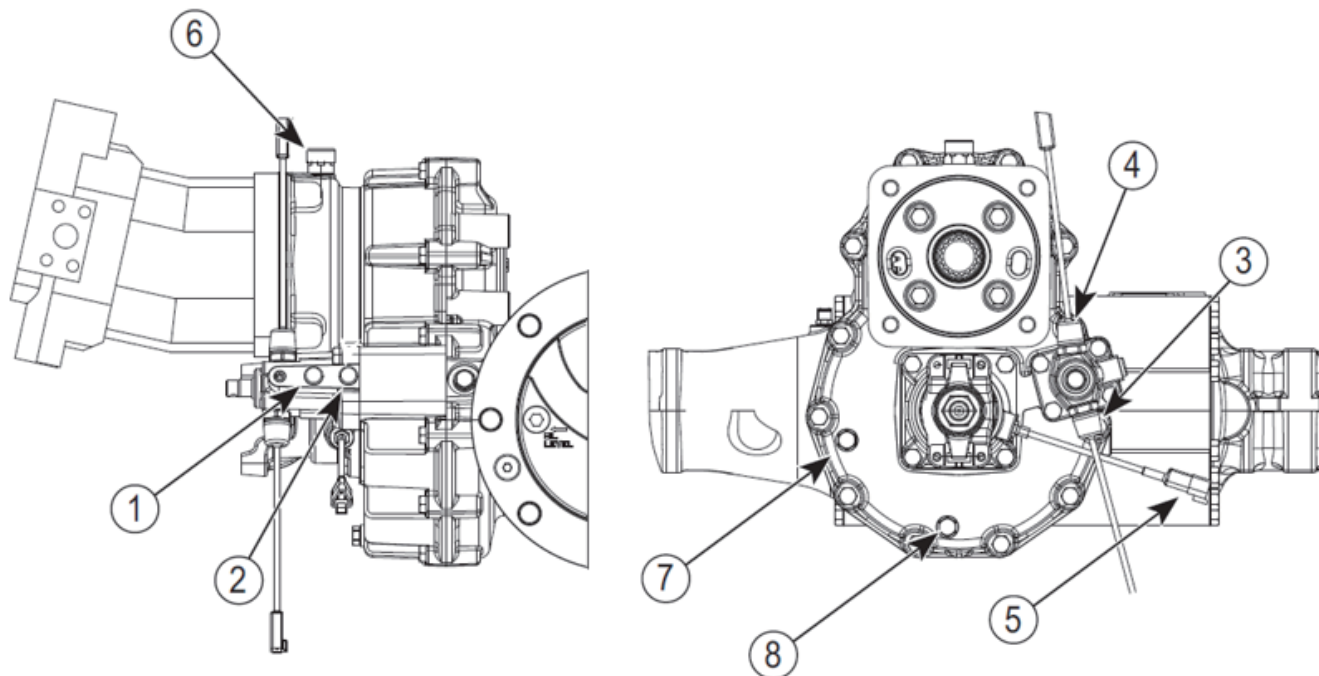

DS2105692

1	Pilot pressure for low speed	5	Speed sensor
2	Measuring point for high speed	6	Breather
3	Switch (optional)	7	Oil filling plug
4	Switch (optional)	8	Oil drain plug

## Working principle - Neutral

Figure 162

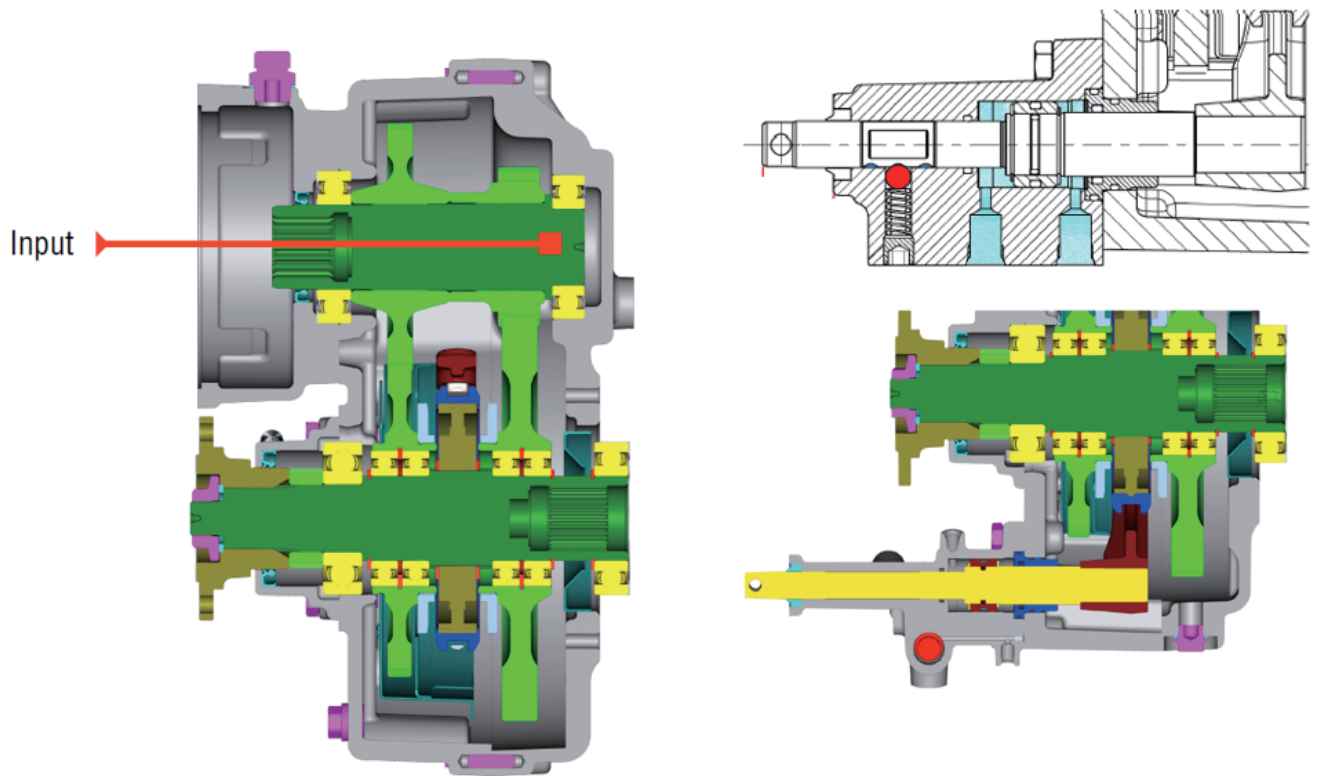

DS2105693

When shift lever is placed on middle position between low and high gear set. (Not engaged with any gear set)It is neutral position.but it does not be performed at machine under normal operating condition.

## Working principle - Low speed

Figure 163

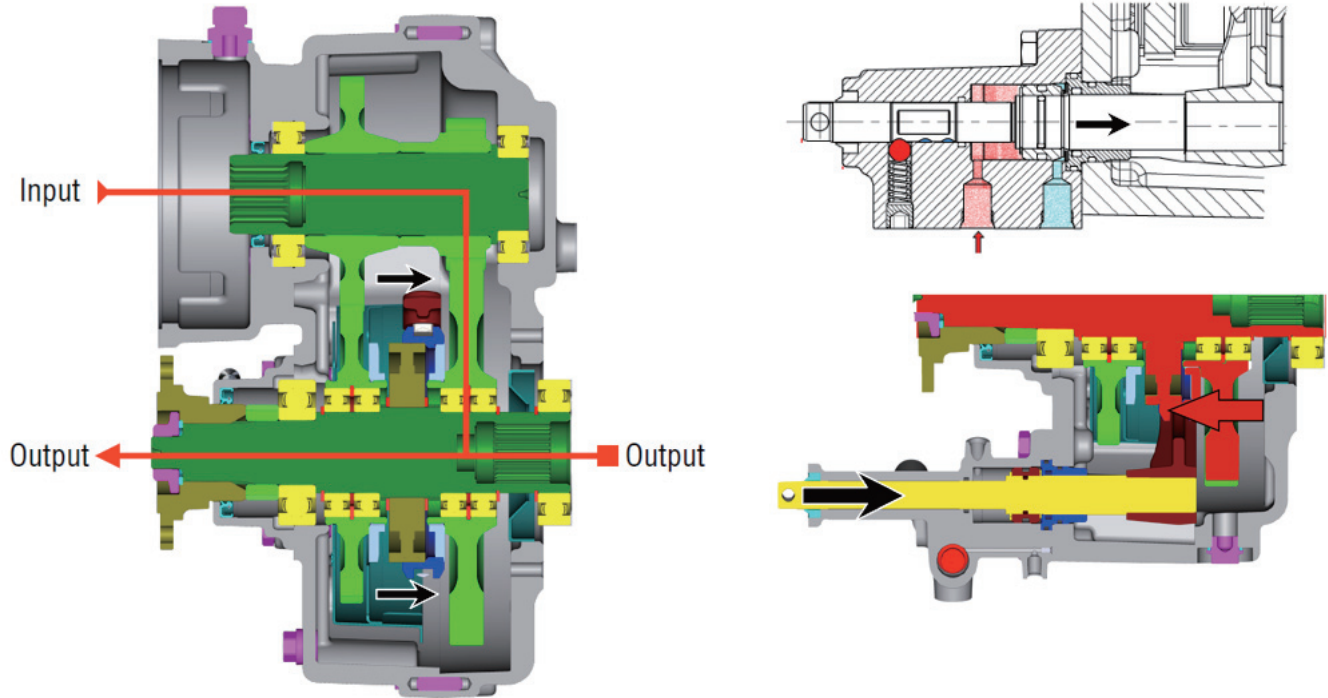

DS2105694

When shift lever is shifted by pilot pressure of the low speed selection solenoid valve, the shifting yoke makes low speed gear set into input gear engage when operator selects low speed SW. Even if engine is stopped, the shift lever is maintained exist position. (No pilot pressure and hold the lever by locking ball)



## Working principle - High speed

Figure 164

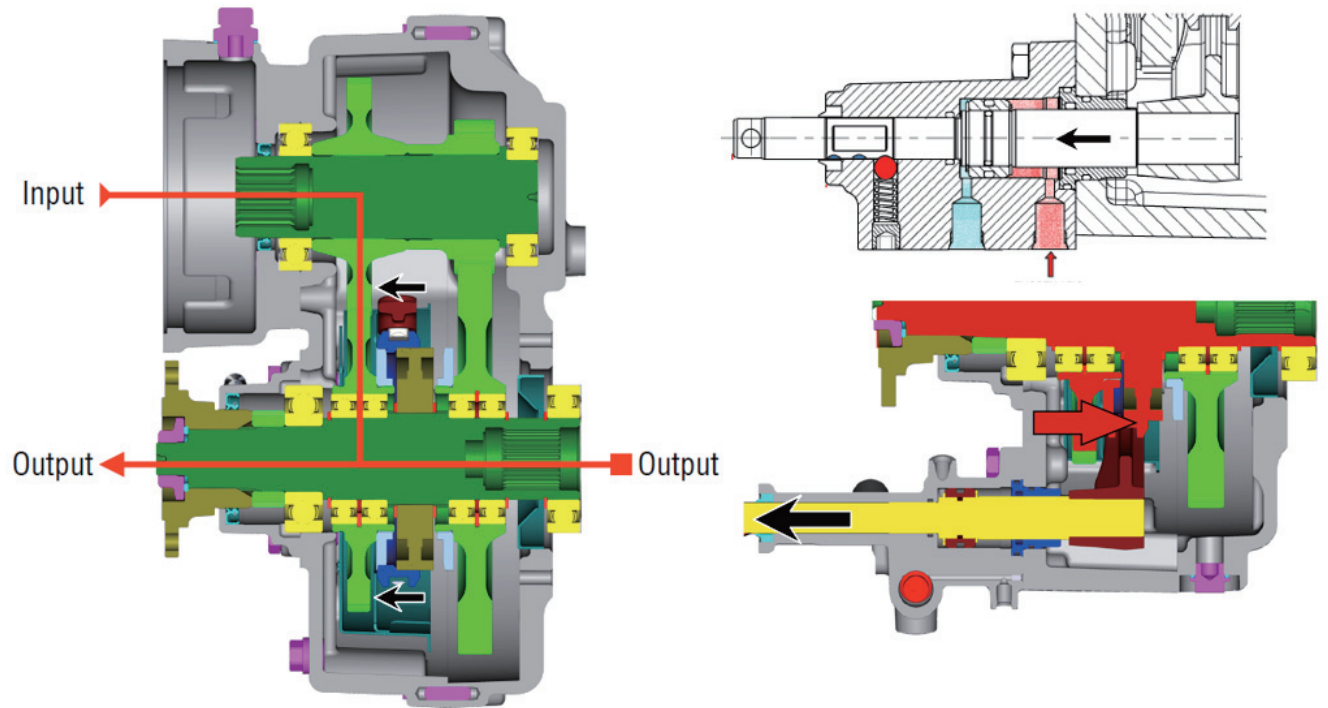

DS2105695

When shift lever is shifted by pilot pressure of the high speed selection solenoid valve, the shifting yoke makes high speed gear set into input gear engage when operator selects high speed SW. Even if engine is stopped, the shift lever is maintained exist position. (No pilot pressure and hold the lever by locking ball)

## Axle

### Overview

Figure 165

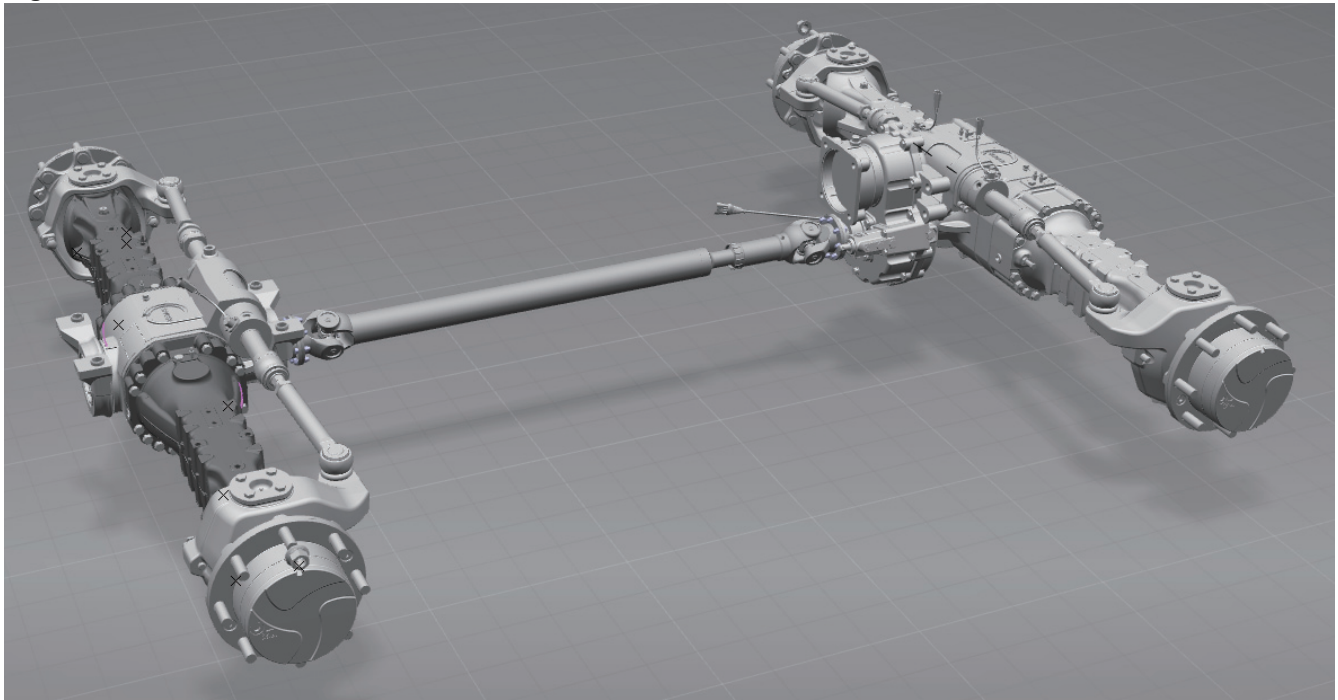

DS2105696

Traveling power is transferred on tire through axle and drive shaft for traveling finally. Front axle is mounted with axle bearing/bracket on center (Oscillating function) and rear axle is mounted on frame with mounting bolt (rigid mounting). There are total 3 optical sensors on front and rear axle (1 front and 2 rear), and it senses steering position of front or rear tire and it uses for inducing tire alignment before setting 2 or 4 wheel steering.

Figure 166

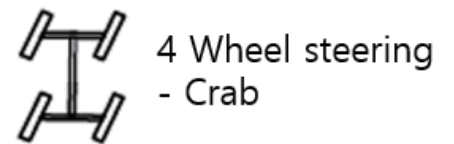
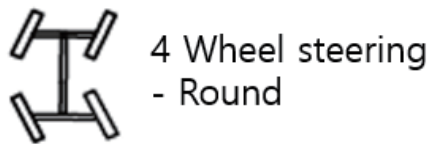
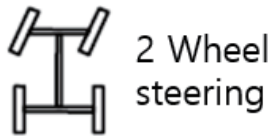
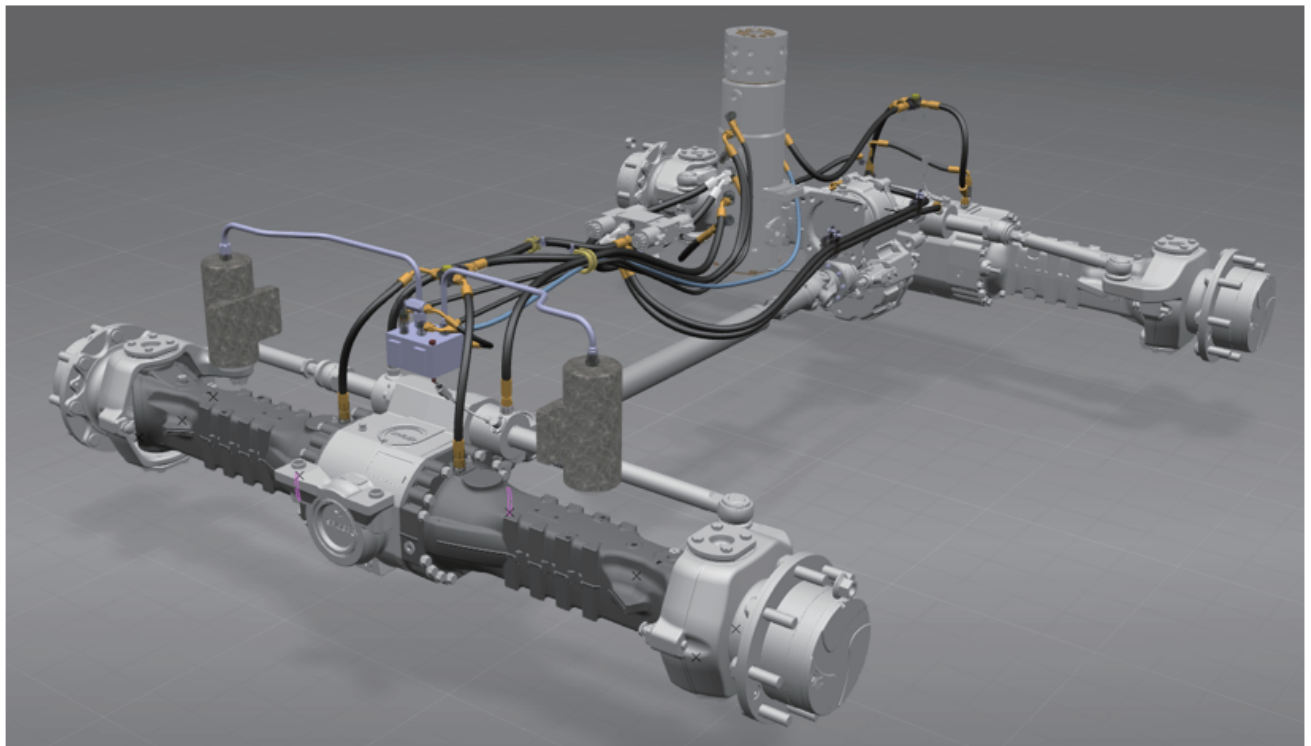

DS2105697

The machine has variable power train option as Two-wheel and Four-wheel steering. (AWS - All Wheel Steering) 2-Wheel steering machine has steering cylinder on front axle. 4-wheel steering machine has steering cylinder on front and rear axle and steering hub each side. Four-wheel steering provides round or crab steering by front and rear axle steering combined. And positioning sensor on an axle senses steering position of each axle for selection type of steering.

**Figure 167**

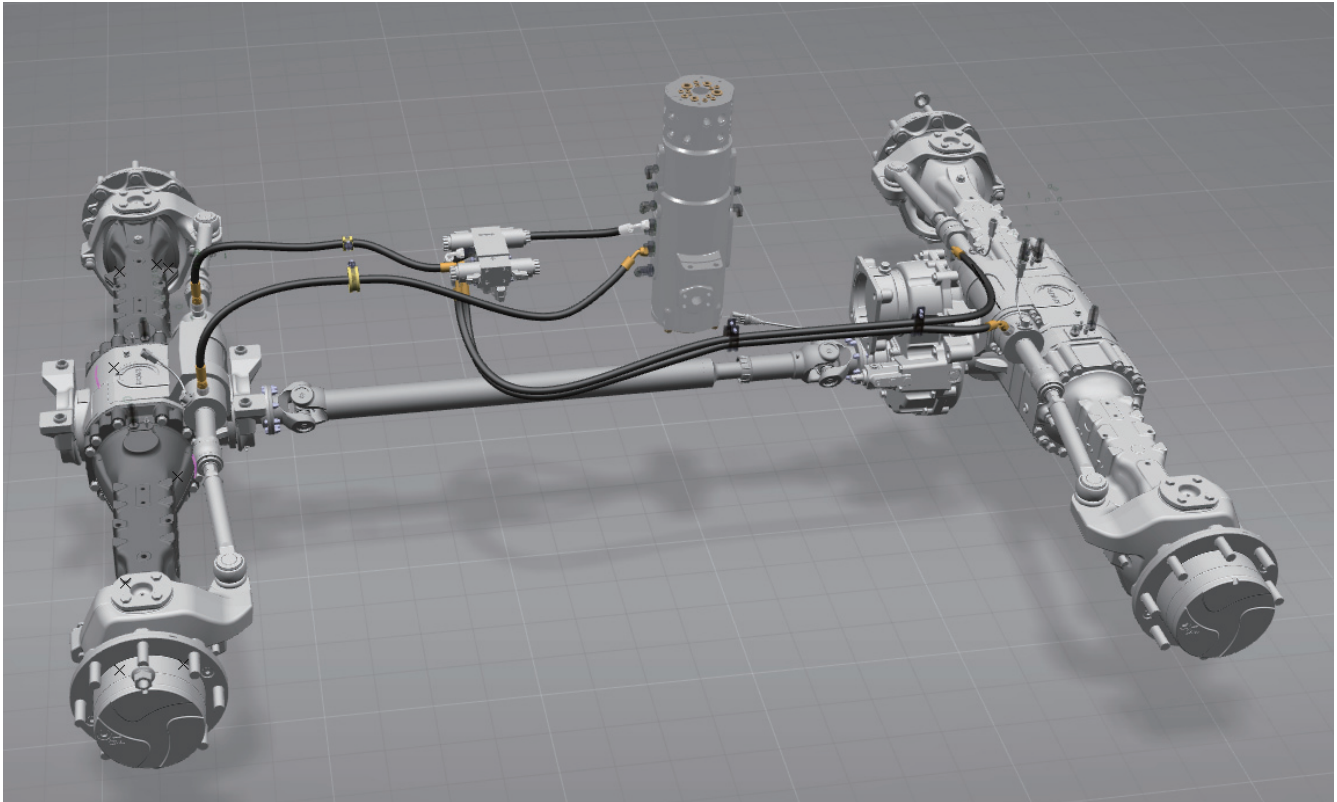

DS2105698

In order to provide 4-wheel steering, 4-wheel steering valve is placed between front and rear axle. It control rear axle steering as round and crab steering based on front steering source flow. Front and rear axle has positioning sensor on steering cylinder and it senses steering straight status before set 2 or 4-wheel steering operation.

# Pilot, Brake and Steering control system

## Pilot system overview

Figure 168

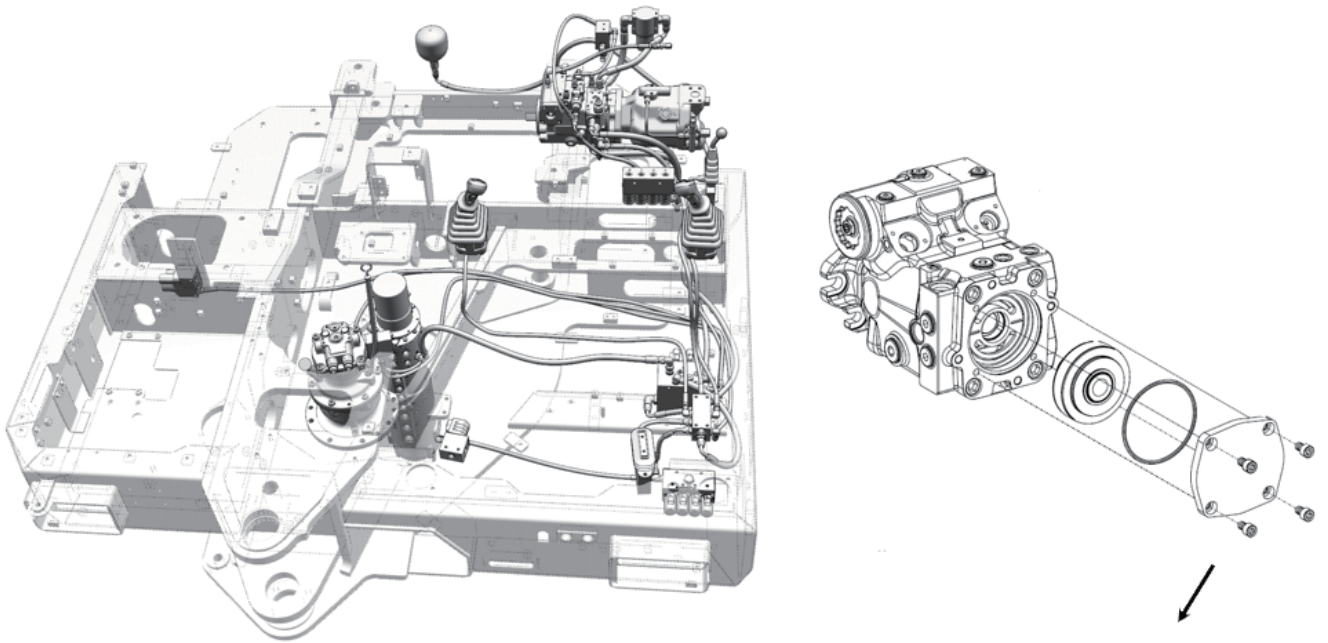

DS2105699

Boost pump in HST pump provides oil flow to pilot system. Discharged oil flow goes to solenoid package valve, 4-solenoid valve directly. When energizing of above solenoid valve, the pilot oil flow goes to chocking cylinder, safety cut off, swing brake release, parking brake release system. And the pilot oil flow provides for high/low speed selection on gear box.

Figure 169

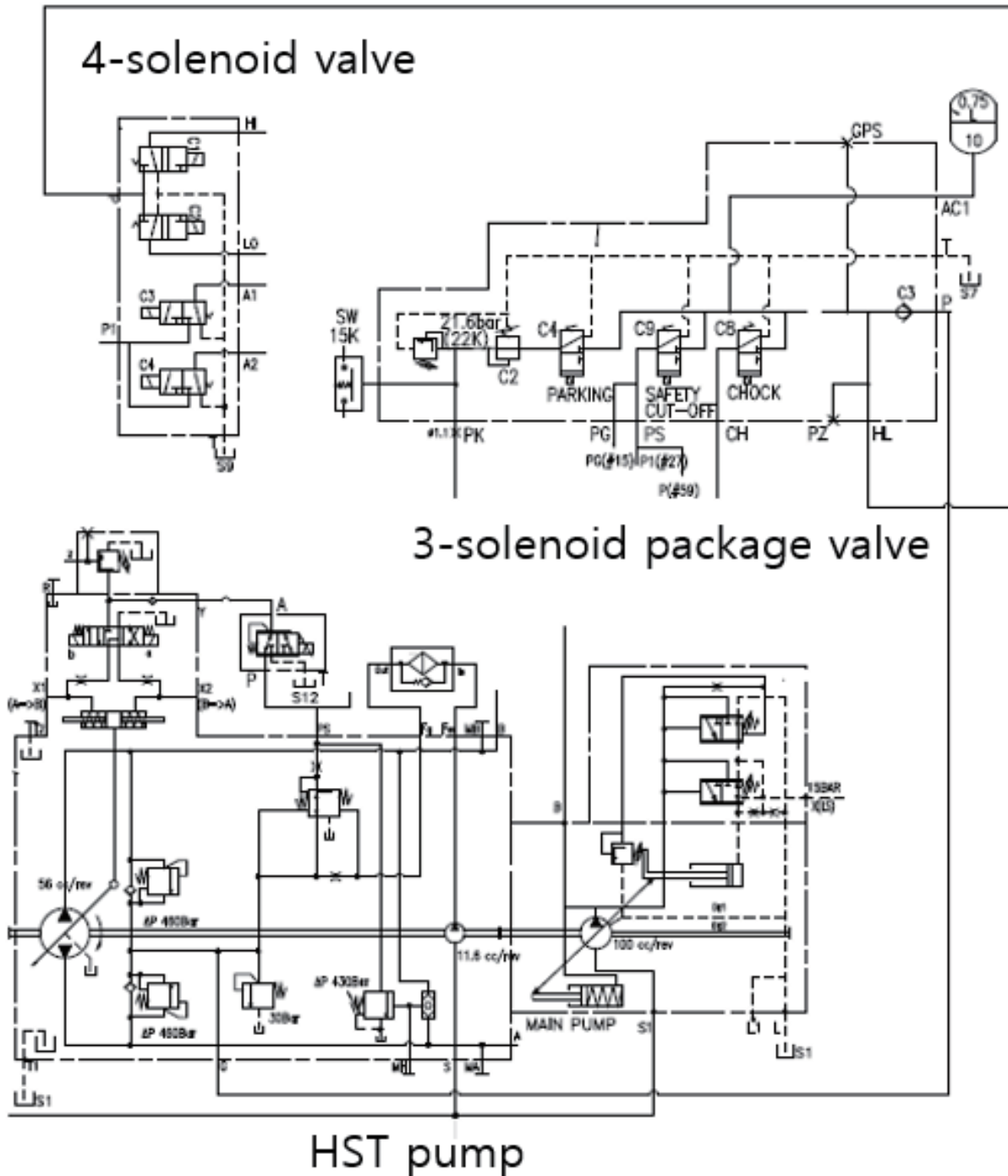

DS2105700

4-solenoid valve controls for

- High speed (#1) traveling on gear box
- Low speed (#2) traveling on gear box
- High speed (Rabbit) of forward traveling on travel motor
- High speed (Rabbit) of reverse traveling on travel motor

3-solenoid package valve controls for

- Checking cylinder locking or releasing
- Safety cut off and swing brake release pressure
- Parking brake release

Source of pilot pressure is from Boost pump on HST pump.30 bar boost relief valve is placed on HST pump and it set 30 bar pilot pressure.

## Steering system overview

Figure 170

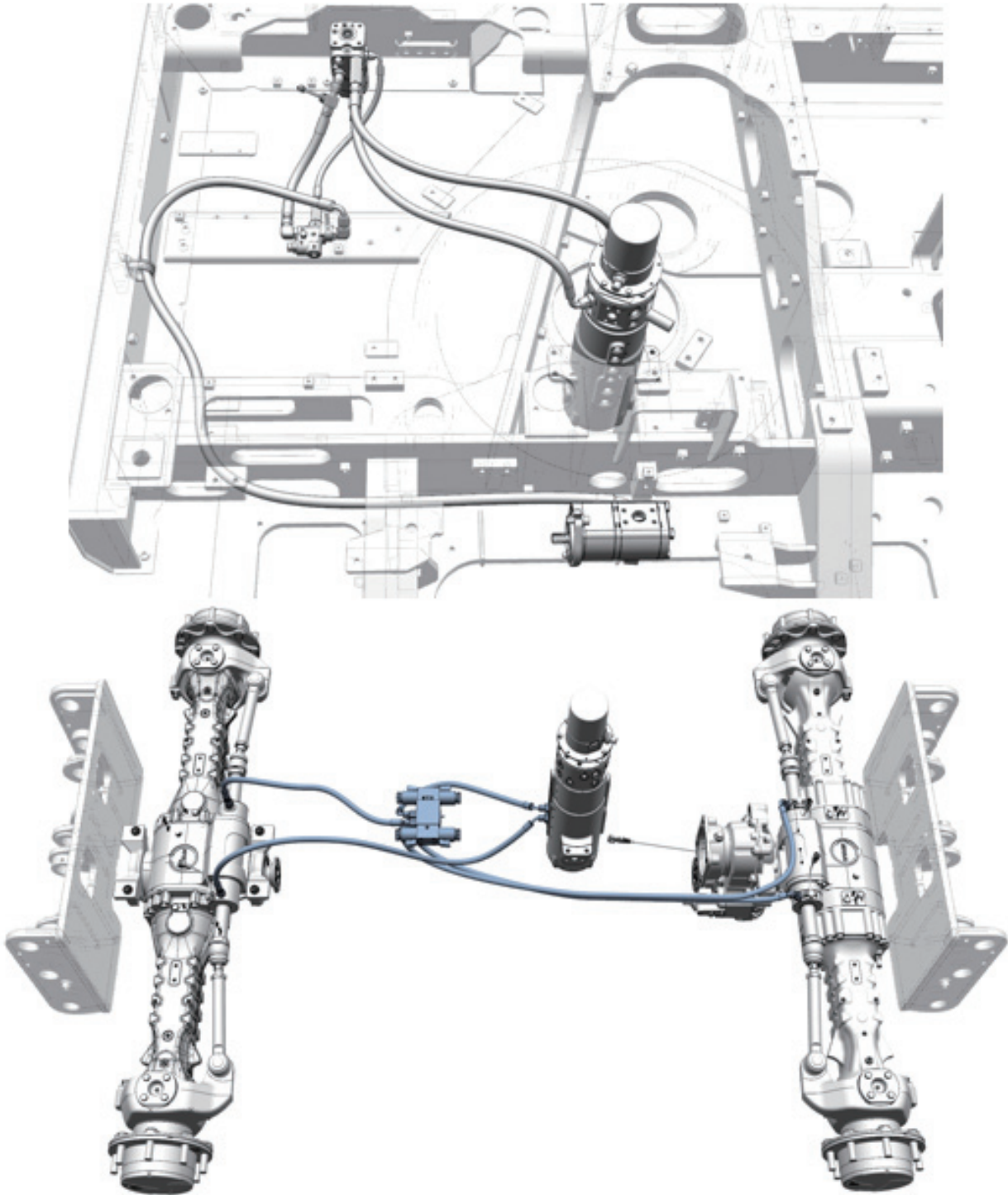

DS2105703

Steering pump is placed on engine PTO with brake pump, the oil flow from steering pump supplies to steering system only. The steering pump is fixed displacement gear type pump, it driven by engine all the time, the discharge oil goes to tank without steering activation. (Open to tank normally) The machine has 2 or 4 wheel



steering depends on steering option selection. 4 wheel steering valve makes steering on rear axle for round and crab steering combining with front steering.

Figure 171

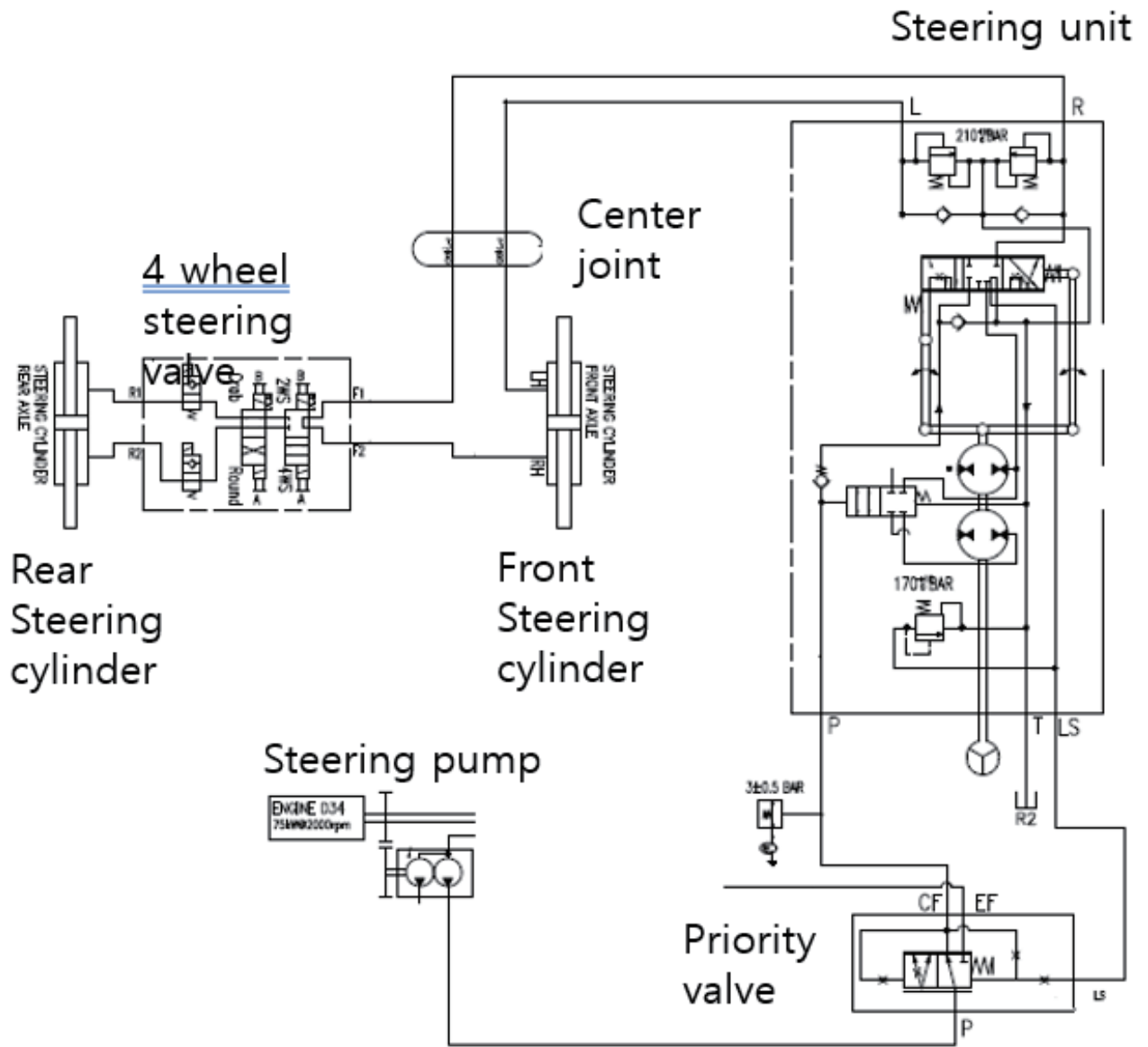

DS2105704

Discharged steering oil flow goes to steering system only. If no steering activation, discharged oil goes to tank through EF port on steering priority valve. When steering activation, the oil goes to steering system only, no more extra oil flow to the tank. Steered oil from steering unit goes to steering cylinder through center joint directly. 4 wheel steering valve makes steered control oil flow into rear axle.

# Brake system overview

Figure 172

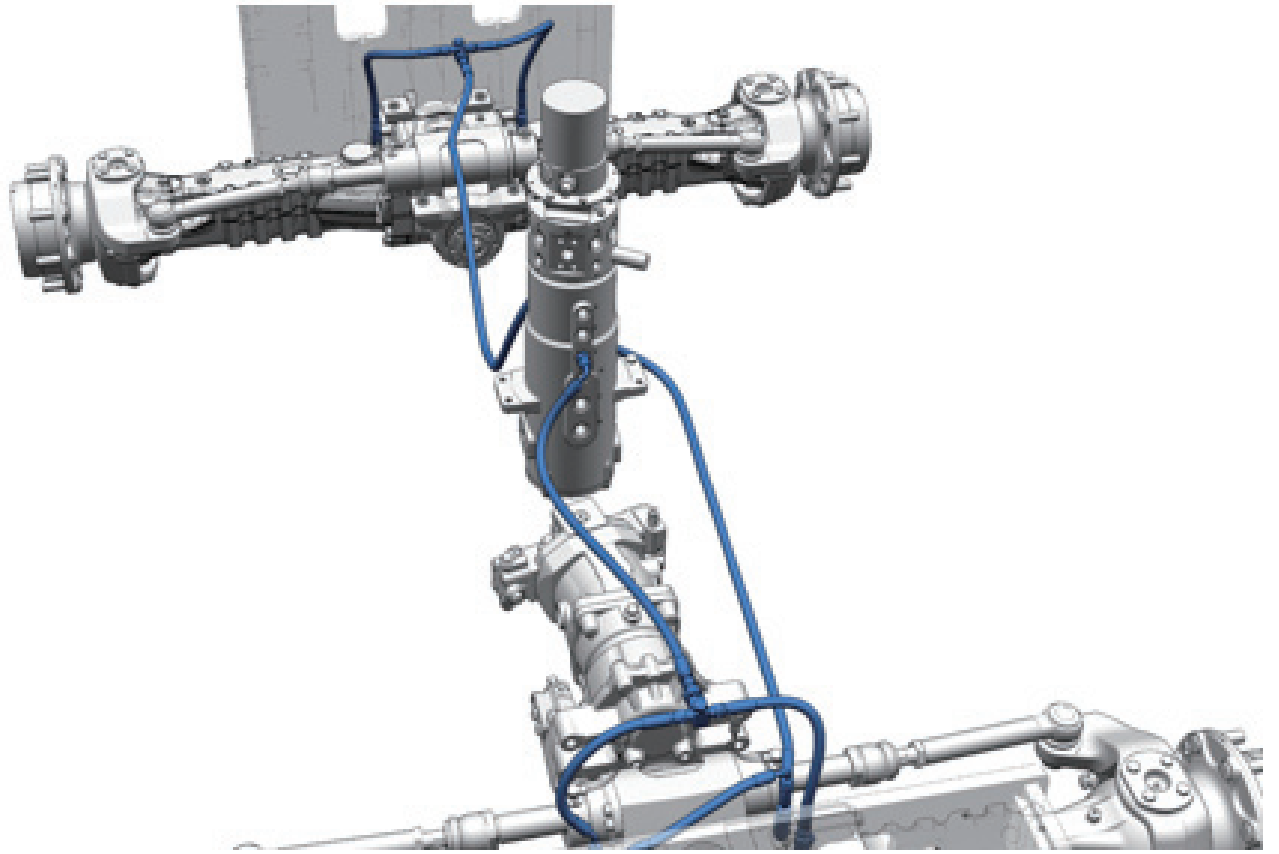
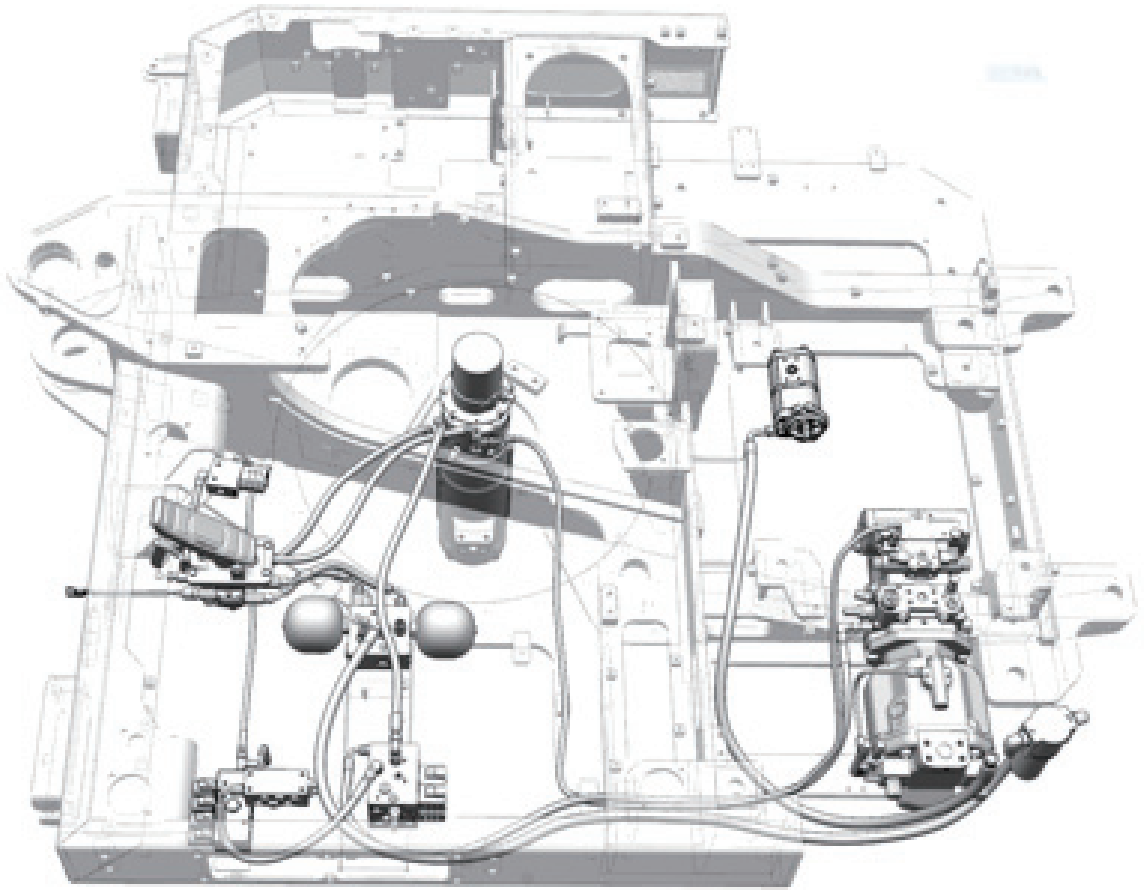

Brake pump is placed on engine PTO with steering pump, the oil flow from brake pump supplies to brake system only. The brake pump is fixed displacement gear type pump, it driven by engine all the time, the discharge oil goes to tank without brake activation. (Open to tank normally) Auto digging (brake) mode is added and it works with activation of auto digging (brake) switch by operator. When operator depresses service brake pedal, the brake pressure is transferred into brake actuator on front and rear axle individually through center joint.

**Figure 173**

**Inching pressure to HST pump**

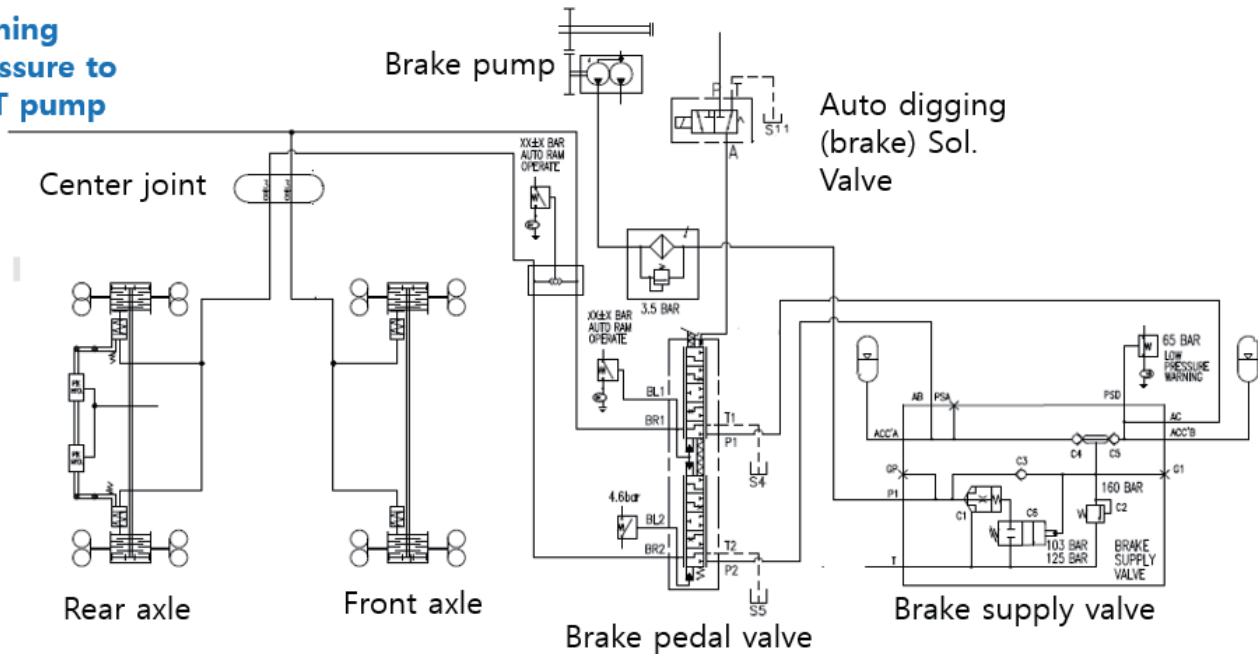

DS2105706

Auto digging mode is activated by auto digging solenoid valve. When the solenoid valve is energized, the pilot pressure makes brake valve be full brake condition. The brake pressure line is connected into HST pump for inching traveling and it controls HST discharging flow amount by inching valve finally.

# Electrical System



# Systems Operation and Description

# Safety Instructions

---

## **WARNING**

---

### AVOID DEATH OR SERIOUS INJURY

Instructions are necessary before operating or servicing machine. Read and understand the Operation & Maintenance Manual and signs (decals) on machine. Follow warnings and instructions in the manuals when making repairs, adjustments or servicing. Check for correct function after adjustments repairs or service. Untrained operators and failure to follow instructions can cause death or serious injury.

---



# Table of Contents

## Systems Operation and Description

Safety Instructions .....	258
Power Supply .....	260
Current Flow (Key Off Position) .....	260
Current Flow (Key ACC Position) .....	261
Current Flow (Key On Position) .....	262
Starting System .....	263
General Starting Circuit .....	264
Emergency Starting Circuit .....	267
Auto Shut Off (After Starting) .....	269
Smart Key (Option) .....	270
Charging System .....	275
Charging Circuit .....	275
AVM System.....	276
AVM .....	276
EPOS system .....	277
CAN Communication .....	277
Power Mode Control .....	279
Work Mode Control .....	279
Flow Control .....	280
Engine RPM Control .....	284
Engine Shut-off Control .....	284
Hammer / Breaker Control .....	286
Low / High and Auto Speed Control .....	286
OWD Control .....	288
Seat Belt Control .....	289
Quick Coupler Control .....	290
Emergency mode of EPOS .....	291
Auxiliary mode of EPOS .....	291
TMS (2.0) .....	292
Joystick Multi-function .....	292
Gauge Panel System .....	293
Gauge Panel .....	293
Service Menu .....	293
Miscellaneous .....	309

# Power Supply

## Current Flow (Key Off Position)

Figure 174

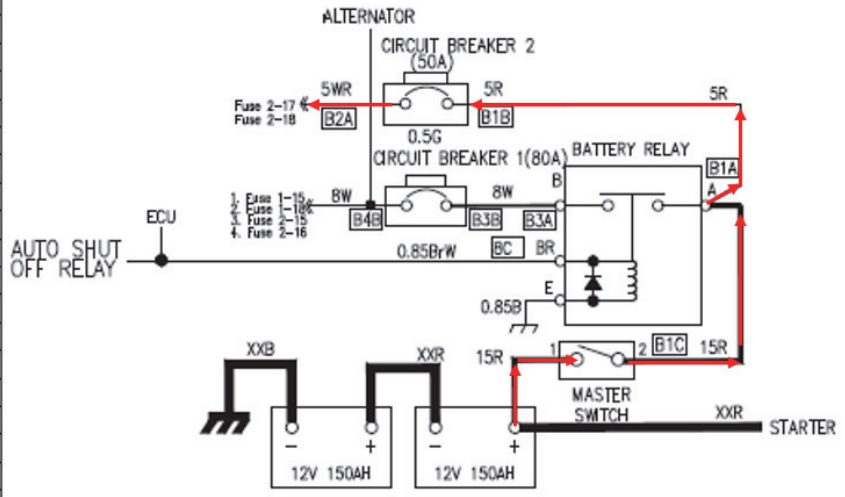
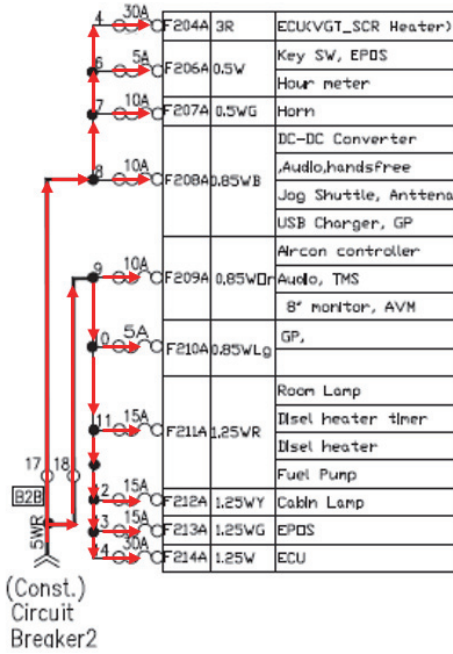

DS2100871

Battery -> Master S/W -> Battery Relay (A) -> Circuit Breaker 2  
-> Fuse box 2 -> Fuses using regular power

# Current Flow (Key ACC Position)

Figure 175

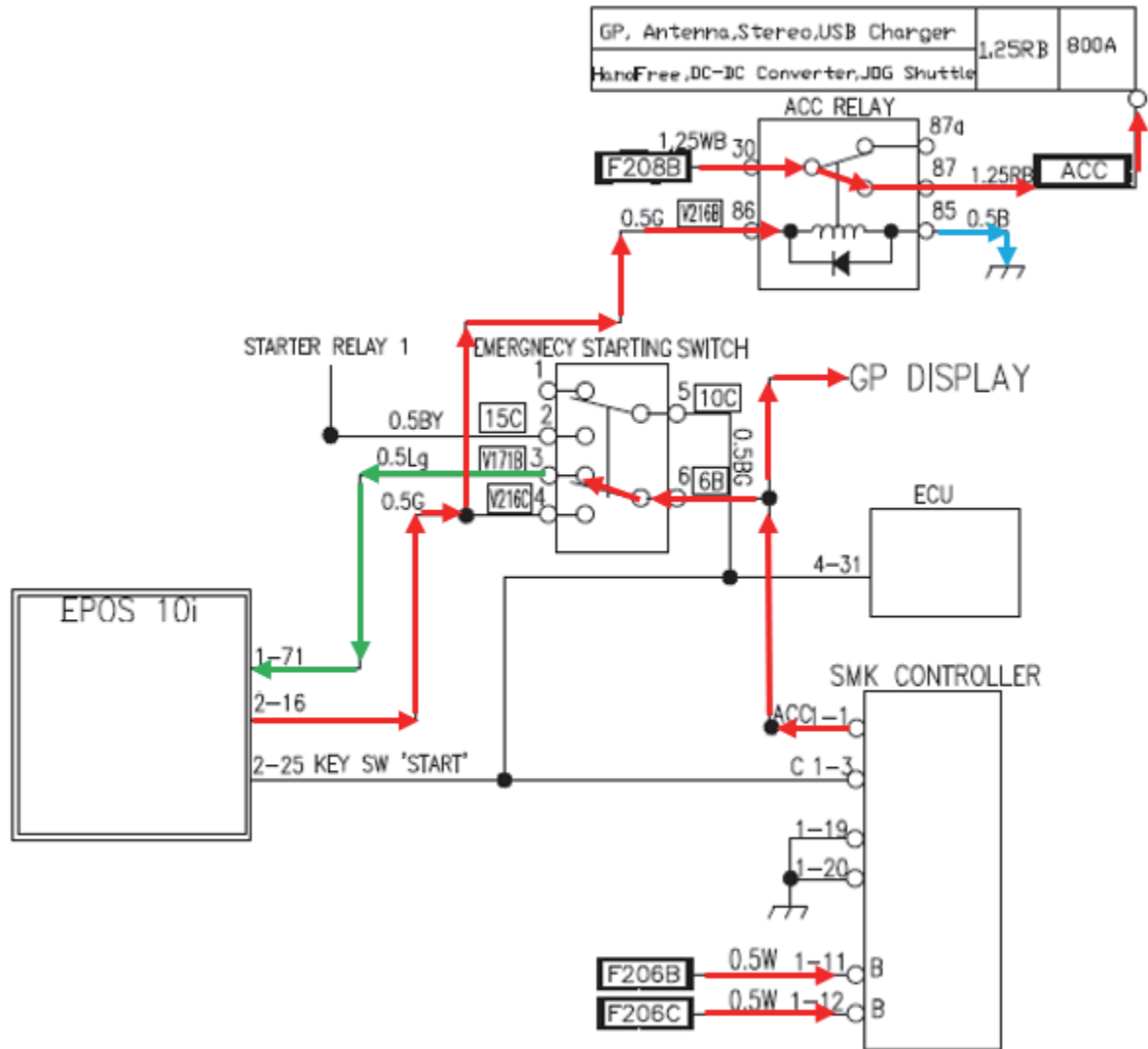

DS2100872

- SMK Controller “ACC” → GP Display and EPOS through Emergency Starting Switch
- EPOS 2-16 → ACC relay 86 to 85 → Ground (relay coil is magnetized)
- Fuse “F208B” → ACC relay “30” to “87” → ACC

# Current Flow (Key On Position)

Figure 176

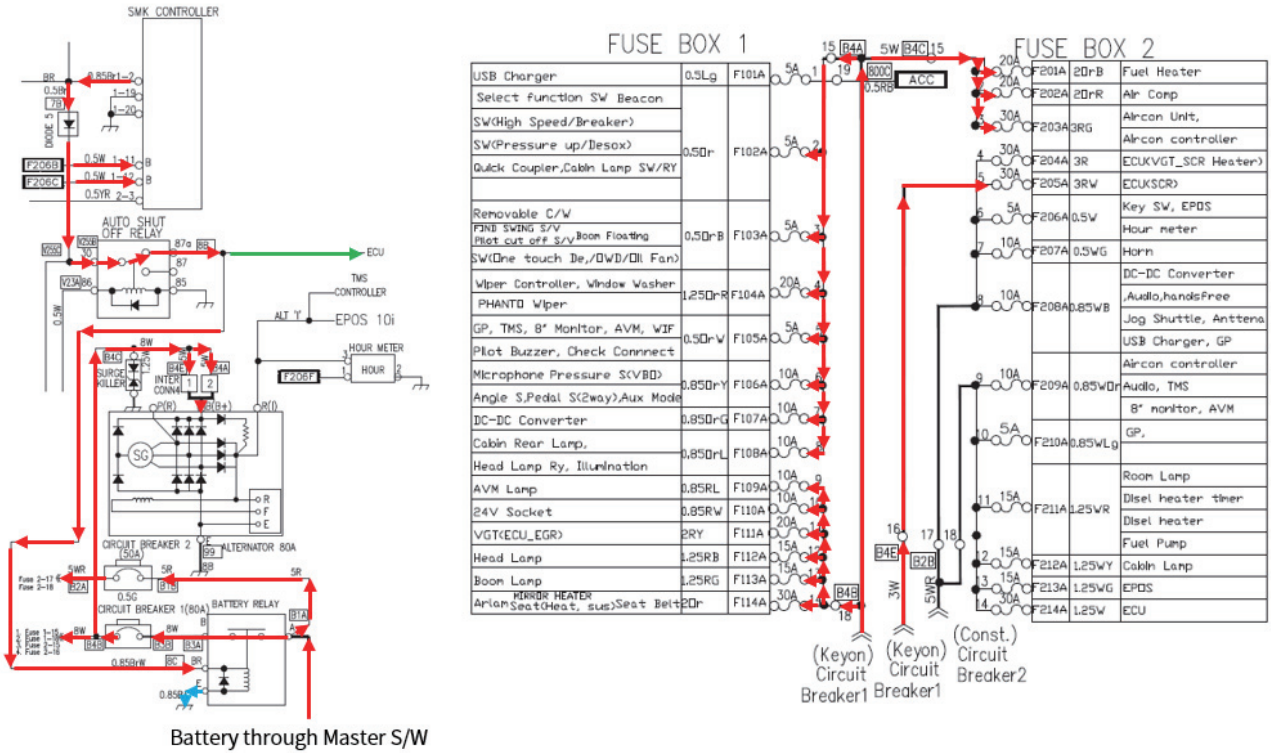

DS2100873

- Current from “BR” of SMK controller is going to ECU and EPOS to inform Key on position.
- Current from Battery relay is going to the alternator to magnetize field coil of alternator initially to prepare generating current when engine running.

# Starting System

# General Starting Circuit

Figure 177

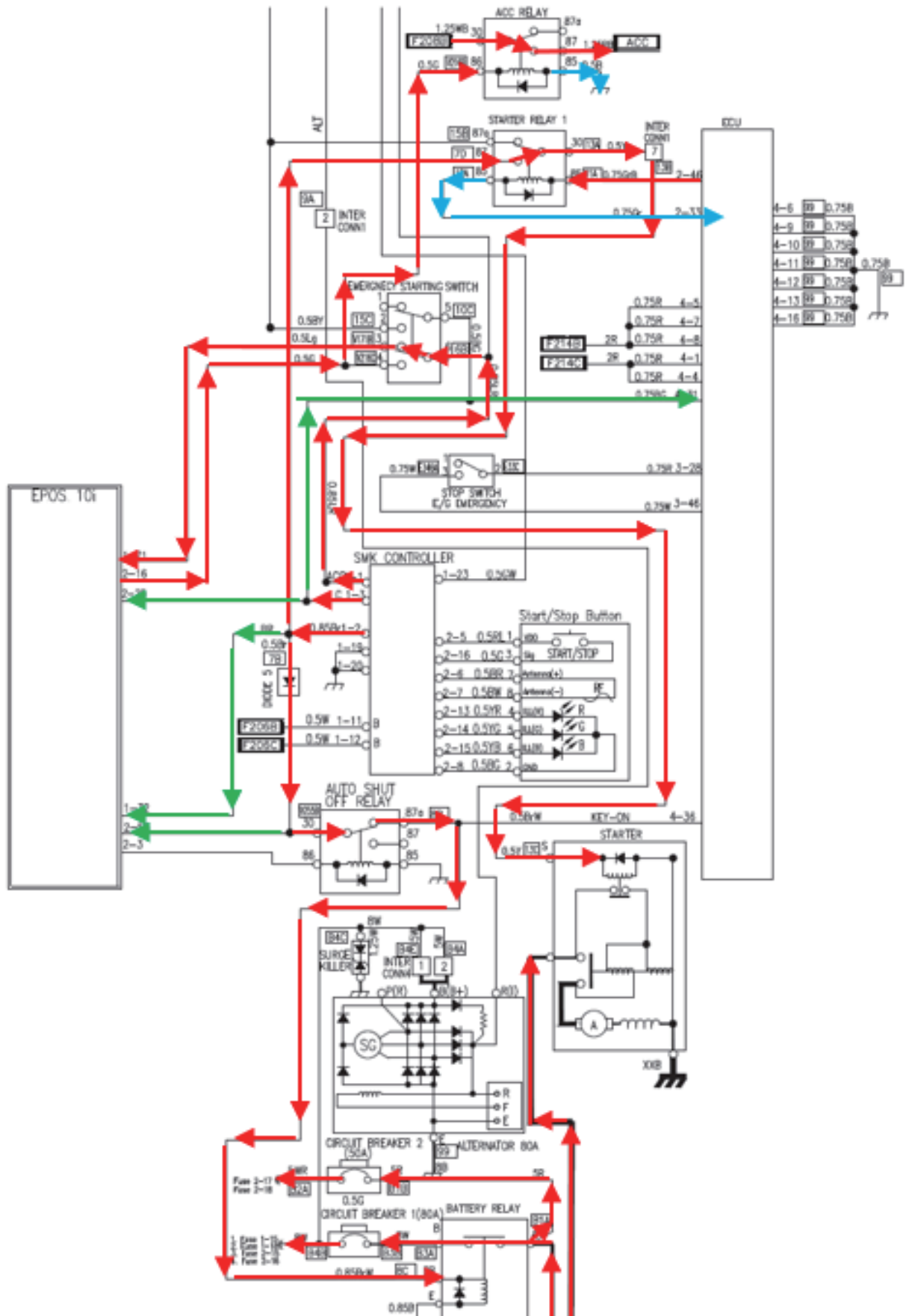

Start position of key: Acc and ON circuits are already connected.

1. SMK "C" → EPOS and ECU(for informing start position)
2. Starter relay coil is magnetized by ECU.
3. SMK "BR" → Starter relay "87" to "30" → Starter "S"
4. Battery → Starter



## Emergency Starting Circuit

Figure 178

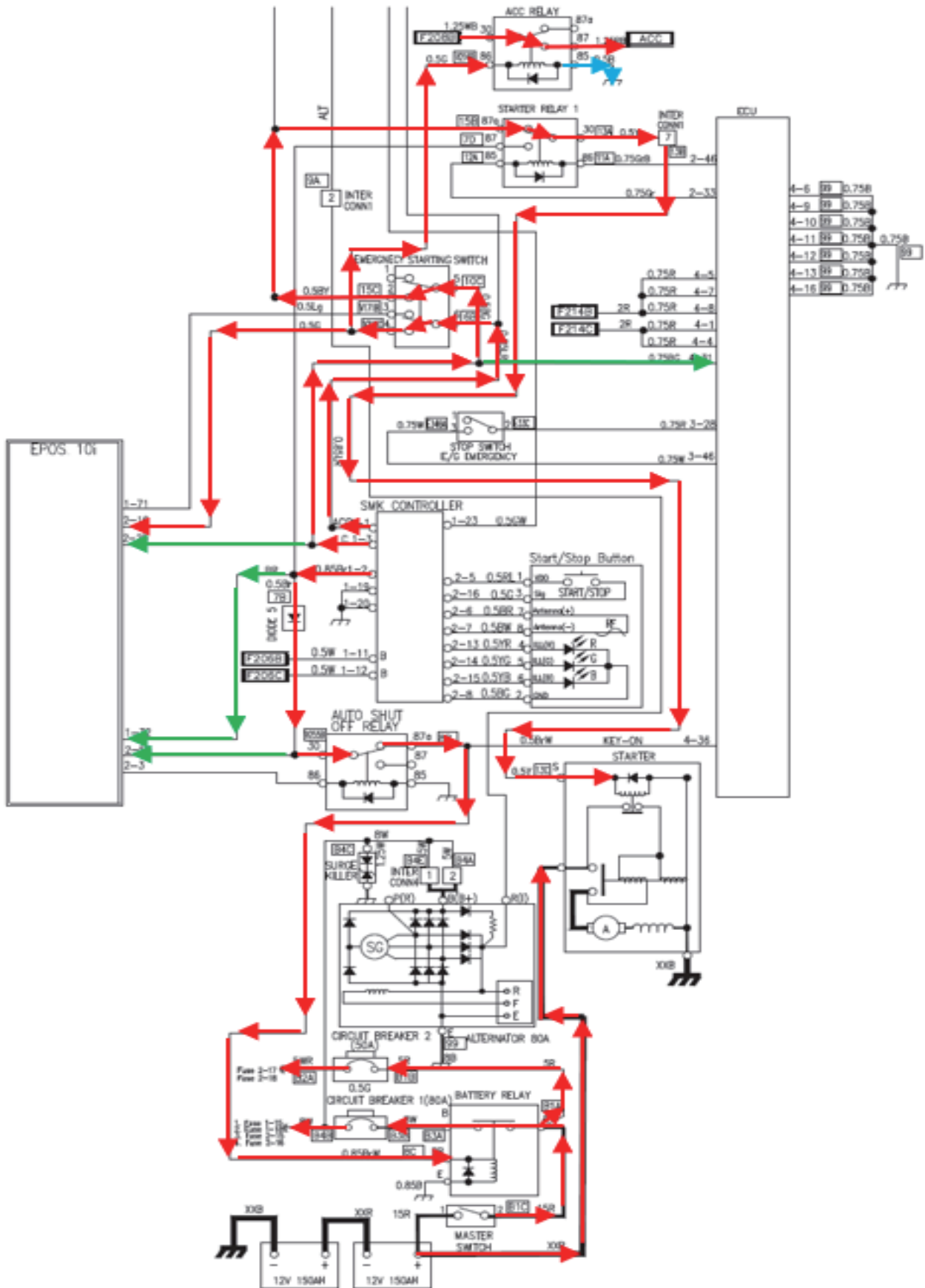

Start position of key with emergency S/W “ON”(Acc and ON circuits are already connected.)

1. SMK “ACC” → Emergency starting switch “6” to “4” → ACC relay “86” to “85” and ground
2. SMK “C” → Emergency starting switch “5” to “2” → Starter relay “87a” to “30” → Starter “S”

**NOTE:** This function is used when the starter relay cannot be controlled by ECU because EPOS is damaged and cannot send and receive machine data through CAN communication with the ECU.

## Auto Shut Off (After Starting)

Figure 179

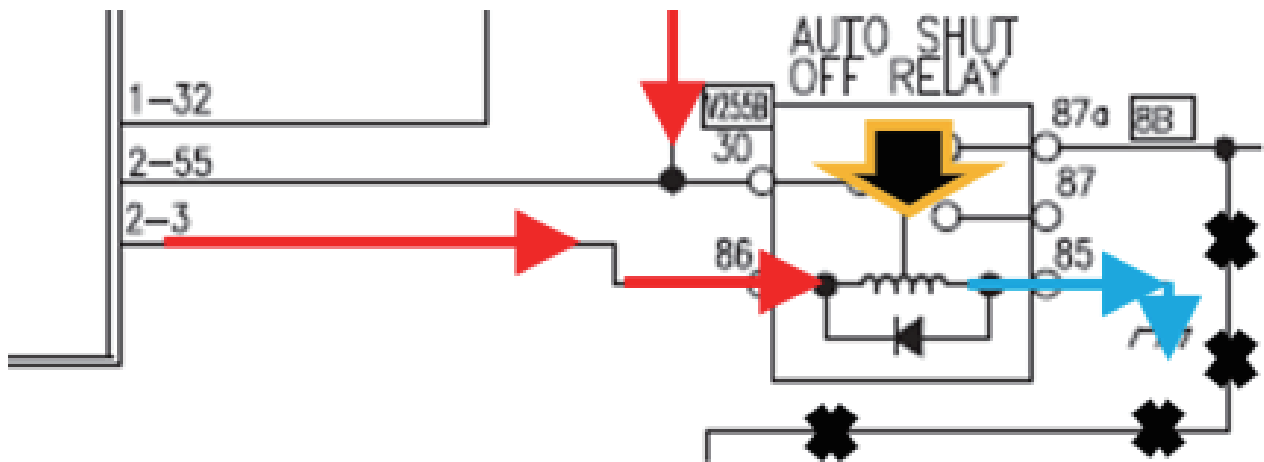

DS2100877

“Auto Shut Off” Working Condition (“Auto Shut Off” activated time is setting on the gauge panel by operator.)

1. Coolant temperature is above 50°C.
2. Hydraulic oil temperature is above 20°C.
3. Pilot Cutoff switch is ON position.

Message pops up on the gauge panel a minute prior to the Shut-off.

Buzzer rings 10 seconds prior to Shut-off.

**NOTE:** When 1-3 conditions meet up, shut-off function can work.

## Smart Key (Option)

RF antenna - for horn, lamp

LF antenna (0.7 ~ 1.0 m) - for FOB

Figure 180

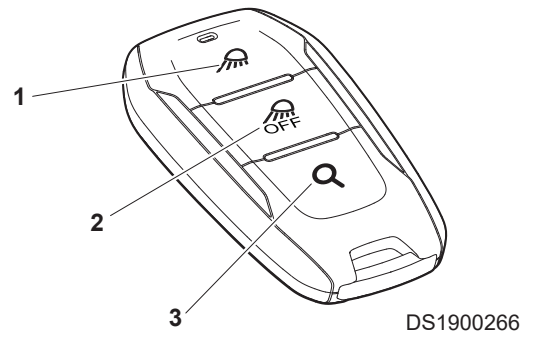
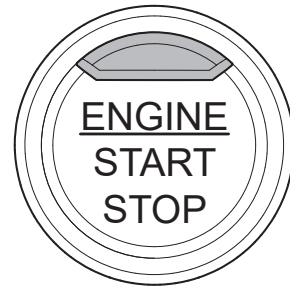

Figure 181



DS1901193

## Starting System

Figure 182

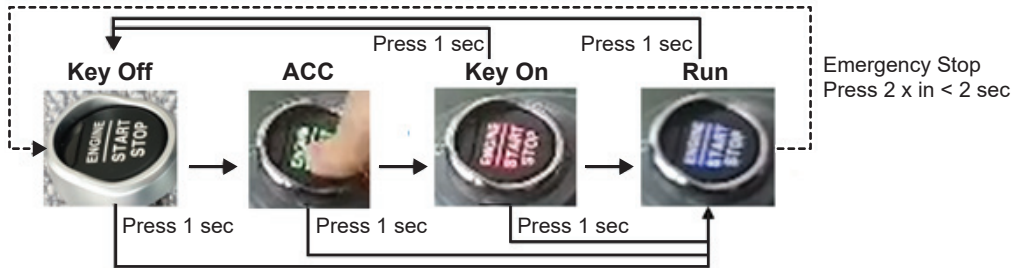

DS1901387

# Smart Key System

Figure 183

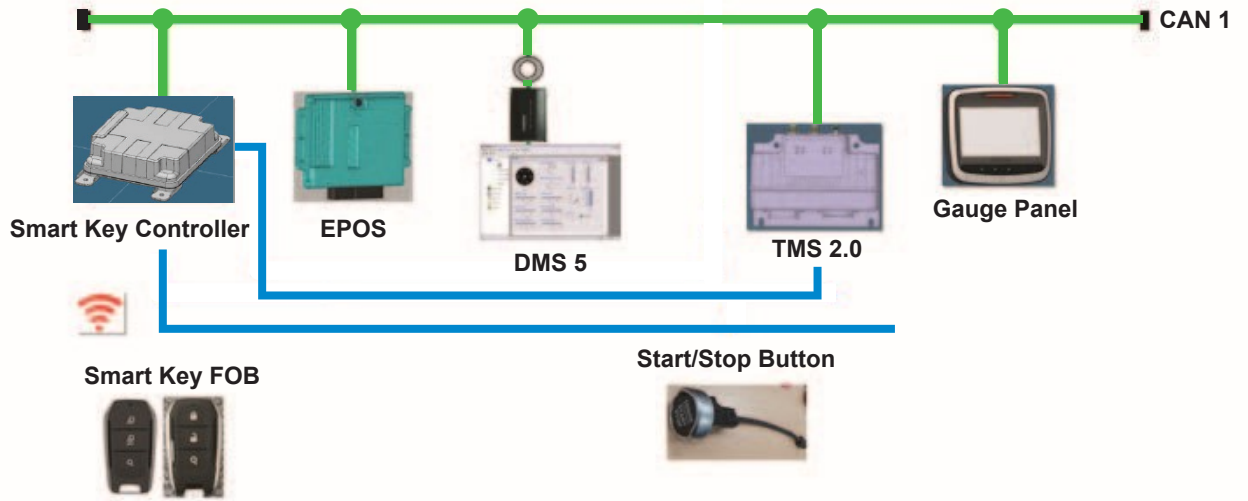

DS1901388

Figure 184

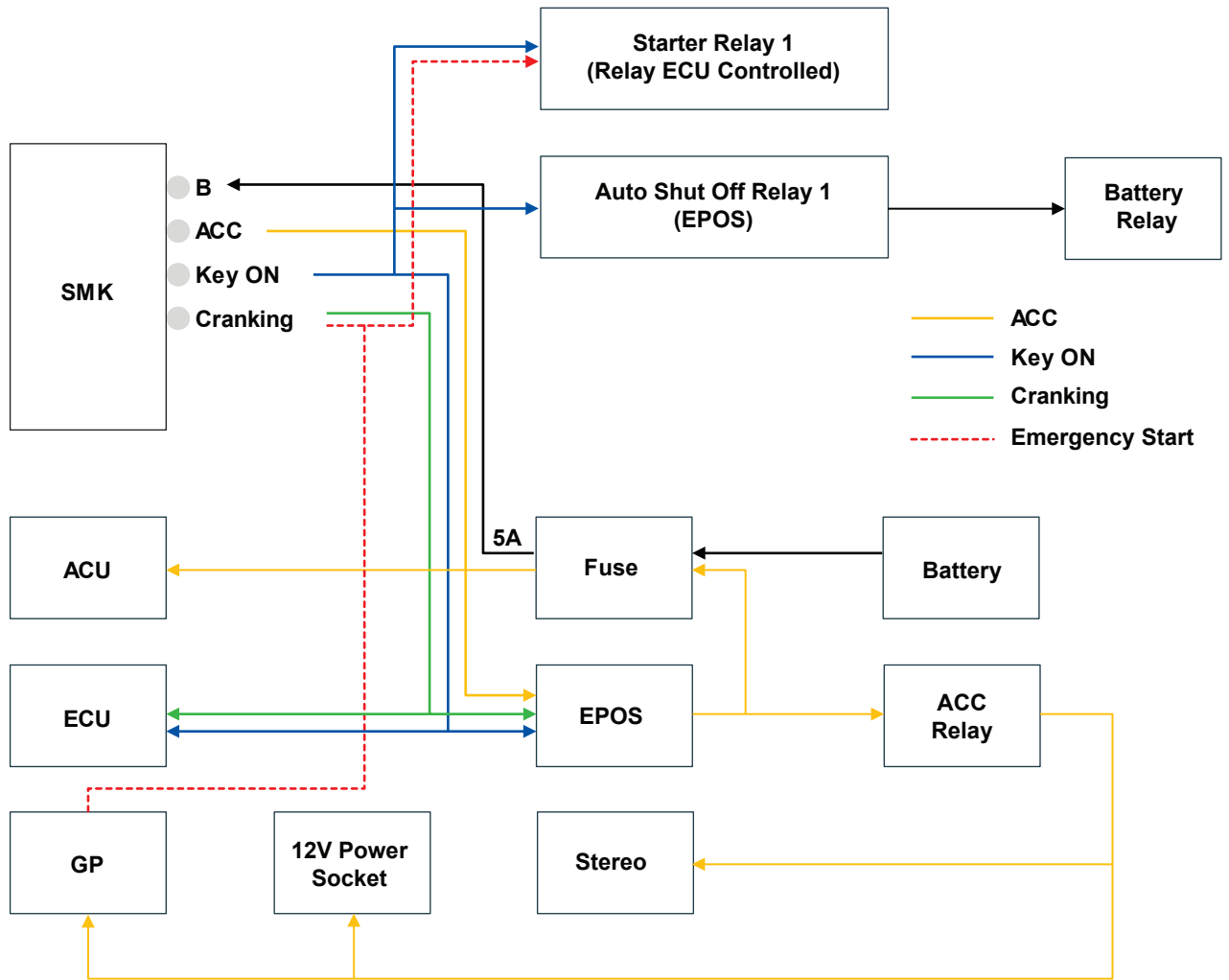

DS1901418

The smart key option provides a number of unique features over the standard key option:

Works as a security device by preventing machine starting if the smart key is not within a certain range of the machine. (It does not cause the machine to stop suddenly if the smart key is removed from within its specified range while the machine is operating).

Allows the operator to turn on the machines front cabin lamps for 1 minute, without having to enter the cabin or turn on the starter switch.

Press button #1 to turn on the machine working lights for 1 min.

Press button #2 to turn OFF the machines working lights (during the 1 minute activation period).

Press button #3 to locate the registered machine.

Pressing button #3 once turns on the working lights and sounds the horn 3 times on the keys 1st registered machine only.

Pressing button #3 twice turns on the working lights and sounds the horn 3 times on the keys 2nd registered machine only.

Pressing button #3 three times turns on the working lights and sounds the horn 3 times on the keys 3rd registered machine only.

Each smart key can be programmed to work with up to a maximum of 6 machines.

The start / stop switch, displays the following colors, to indicate its operating status:

- No illumination - Machine OFF
- Green illumination - Machine in ACC mode.
- Red illumination - Machine in ON mode.
- Blue illumination - Engine cranking and machine running

Pressing the start button for less than 1-second changes the machines state from:

- Off to ACC
- ACC to On
- On to Off

Pressing the start button for more than 1 second from Off, ACC or On, will make the start button activate the starter, provided no other interlocks are present (password protection, pilot isolator raised, etc)

Pressing the start button for more than 1 second with the engine running will cause the machine to stop.

**NOTE:** *In an emergency, pressing the start switch 3 times within 2 seconds will stop the machine.*

When the machine is put into the ACC condition, the smart key controller starts searching for 10 seconds for the smart key. If the smart controller fails to locate the smart key, the machine will display the smart key not present warning message on the gauge panel.

**Figure 185**

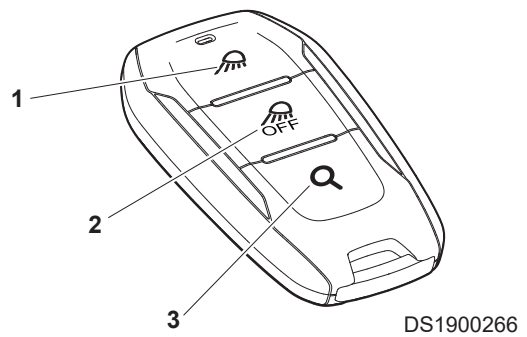

One minute after the smart key controller fails to find the smart key, the pop up will be turned off.

The smart key controller will search again twice for the smart key, once 2 minutes after ACC On and the last time 5 minutes after ACC On, then if it still does not find the smart key, the machine will be turned Off.

### Limp Home Function

The smart key system is provided with a limp home function, in case of smart key battery failure or because the smart key controller cannot recognize it due to electrical noise, etc. To activate the limp home function, the smart key must be used directly on the start / stop button for 3 seconds (as shown below).

Figure 186

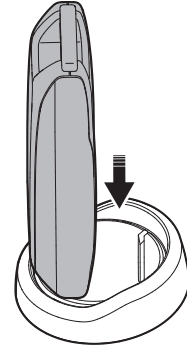

DS1900267

### Registering Smart Keys.

It will be possible to register a smart key to a machine by 2 methods:

- With DMS 5
- Through Hyundai Connect

**NOTE:** *Once these methods are finalized, online learning will be made available showing both methods.*

**NOTE:** *Other features that use the Smart Key are under development.*

Figure 187

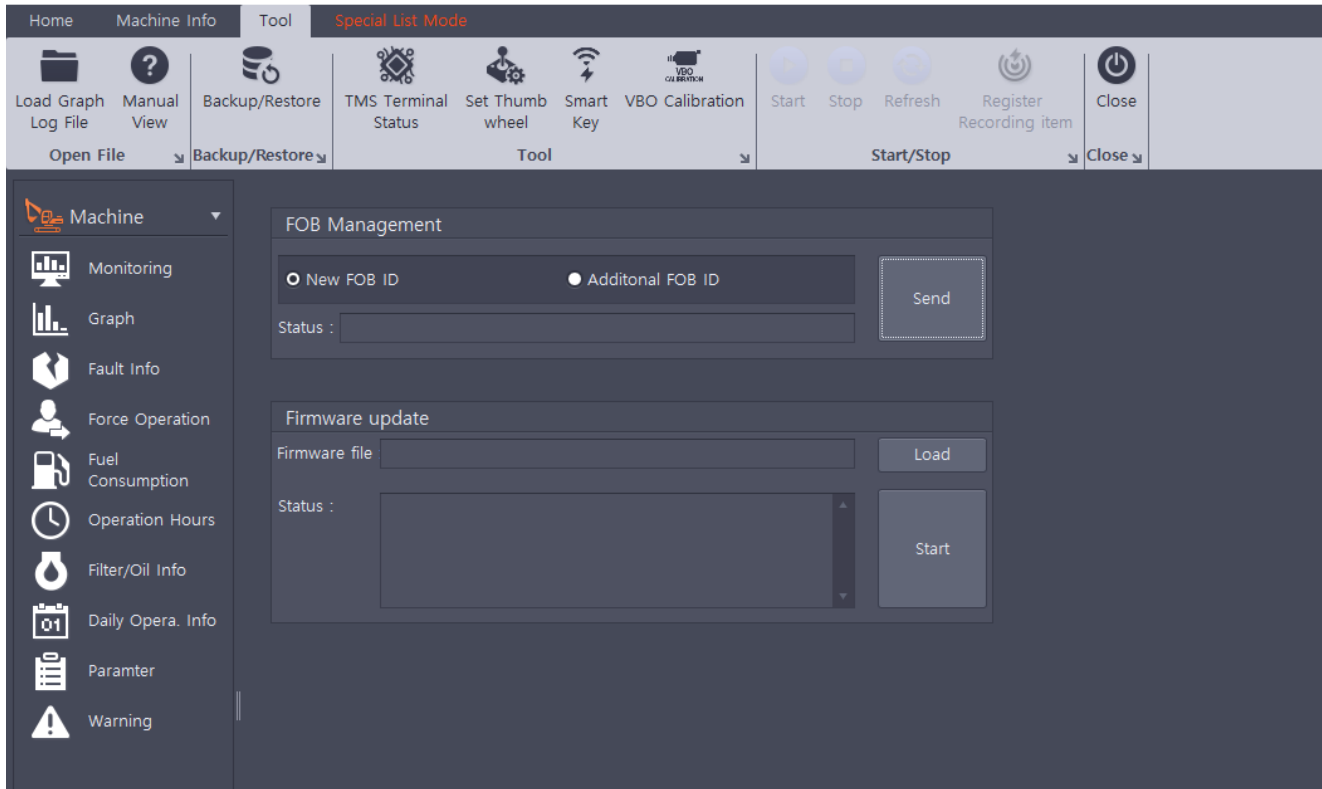

DS1901417



# Charging System

## Charging Circuit

Figure 188

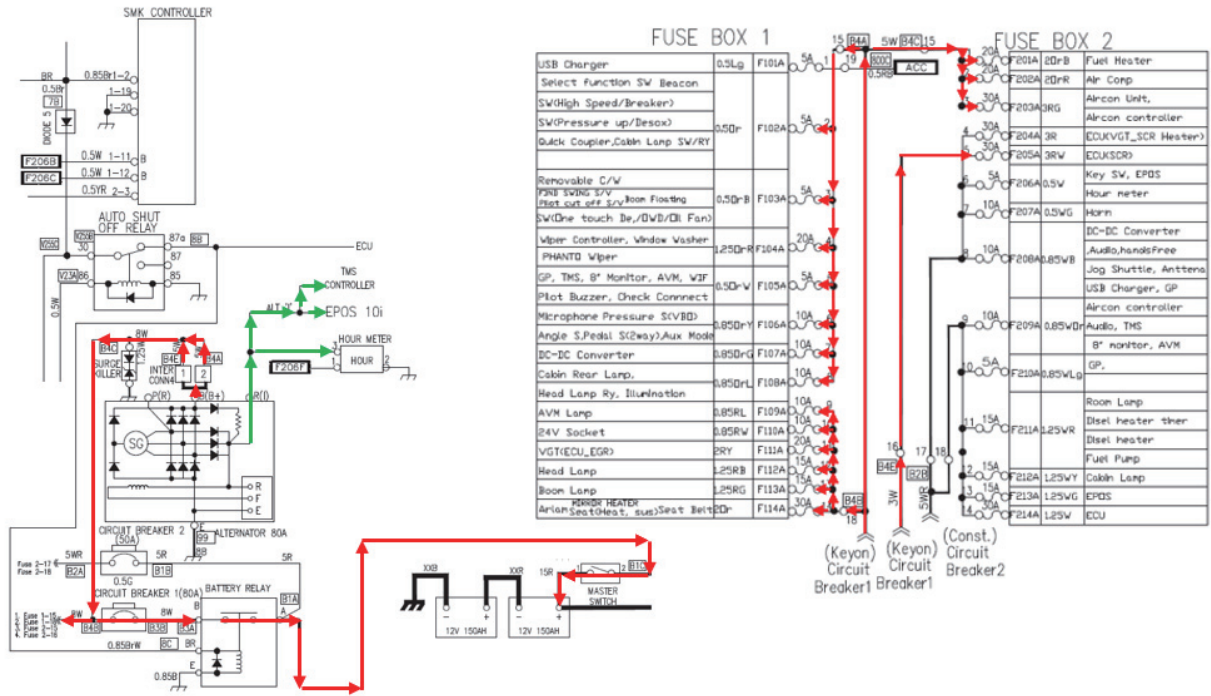

DS2100874

Alternator B+ → Circuit Breaker 1 → Battery Relay “B” to “A” → Master Switch → Battery (for charging the battery)

Alternator B+ → Fuse Boxes (for supplying the electric power to each device)

# AVM System

## AVM

Length sensitivity of the ultrasonic sensor

1. Step 1: Approx. 0.5 ~ 0.9 m
2. Step 5: Approx. 0.9 ~ 1.8 m
3. Step 10: Approx. 1.8 ~ 2.7 m

Figure 189

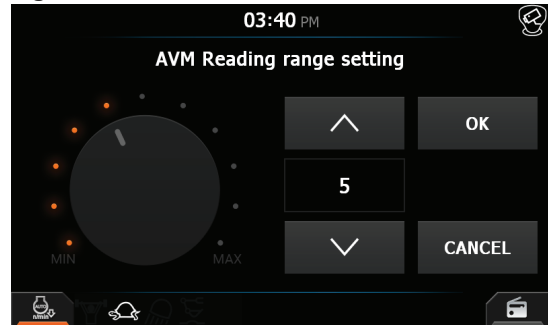

DS1900339

Figure 190

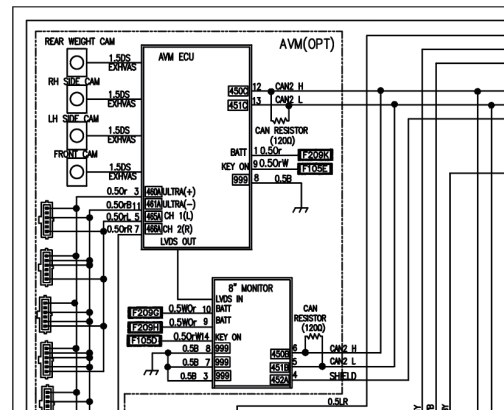

DS2101177

# EPOS system

No.	Controller	
1	Supply Voltage	10 ~ 32V
	Normal Operation Voltage	24V
	Standby, in the 24V	300 ±10 [mA]
	Loaded, in the 24V	max. ±30 [A]
2	Digital Inputs for Switch (Active High)	0 ~ 32V
	Voltage Range	H: >10
3	DIH / DIL Inputs (ADC Read)	0 ~ 32V
	Voltage Range: Digital Signal	L: < 1, H: > 5
	Voltage Range: Analog Signal	0 ~ 5V
4	Analog Voltage Inputs	
	Voltage Range (Low Speed Sensor: 10)	0 ~ 5V
	Voltage Range (High Speed Sensor: 3)	0 ~ 5V
5	PWM / Frequency Input	
	Voltage Range	1 ~ 32V
6	EPPR: High Side	
	Current Range	0 ~ 1.65A
7	Solenoid / Relay: High Side	
	Current Range	0 ~ 1.65A
8	Relay: Low Side	
	Current Range	0 ~ 0.5A
9	Power Output	5Vdc, 200mA

Figure 191

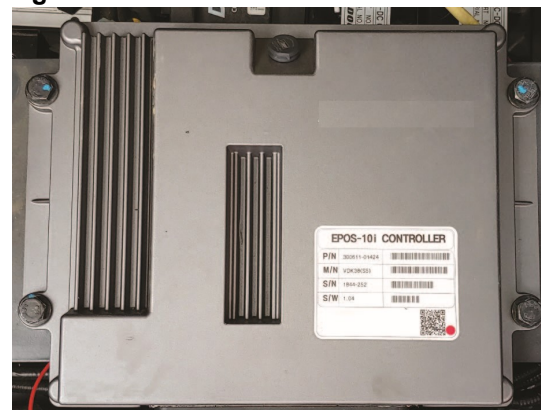

DS1901575

## CAN Communication

The different control units communicate with each other via CAN link. The nodes in the system monitors its communication links. If a fault is detected in the communication link supervision the node informs the operator about the fault.

Figure 192

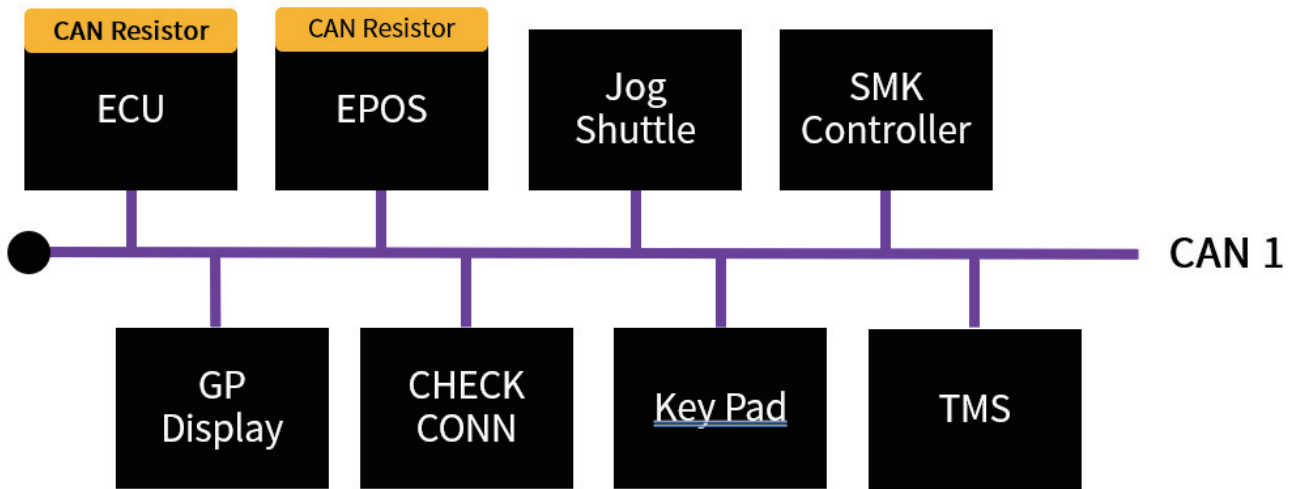

DS2101178

CAN 1 consists of ECU, EPOS, Jog Shuttle, SMK Controller, GP Display, TMS, Check Connector, Key Pad. There are CAN resistors into ECU and EPOS for CAN 1, and each CAN resistor is 120 ohm.

Figure 193

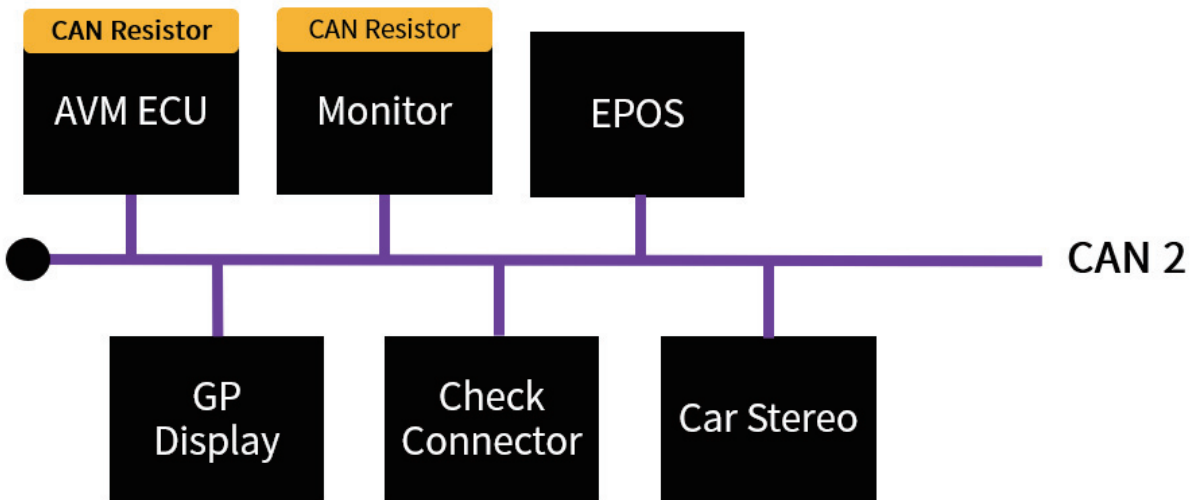

DS2101179

CAN 2 consists of AVM ECU, AVM Monitor, EPOS, GP Display, Check Connector and Car Stereo. There are CAN resistors into AVM ECU and Monitor for CAN 2, and each CAN resistor is 120 ohm.

CAN 3 consists of ECU and Check Connector. There are CAN resistors into ECU and Diagnosis tool connector for CAN 3, and each CAN resistor is 120 ohm.

Figure 194

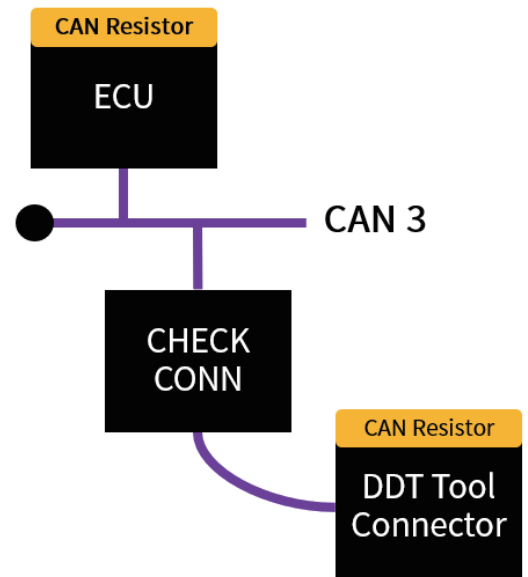

DS2101180

### Power Mode Control

EPOS controls engine RPM and pump torque based on the operator's demanding mode.

Figure 195

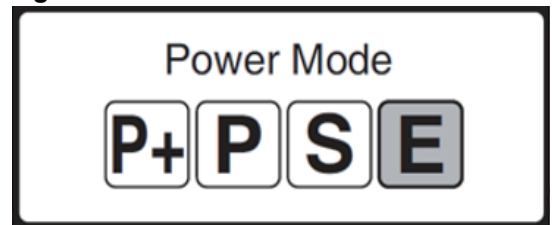

DS2101250

Mode	RPM	Input Power [PS]
P+	1900	175
P	1800	161
S	1700	148
E	1600	133

### Work Mode Control

EPOS controls engine RPM and pump torque based on the operator's demanding mode.

Figure 196



DS2101183

Mode	RPM
Digging	1600~1800
Lift	1500

Mode	RPM
Hammer	Set RPM by operator
Shear	Set RPM by operator

## Flow Control

Figure 197

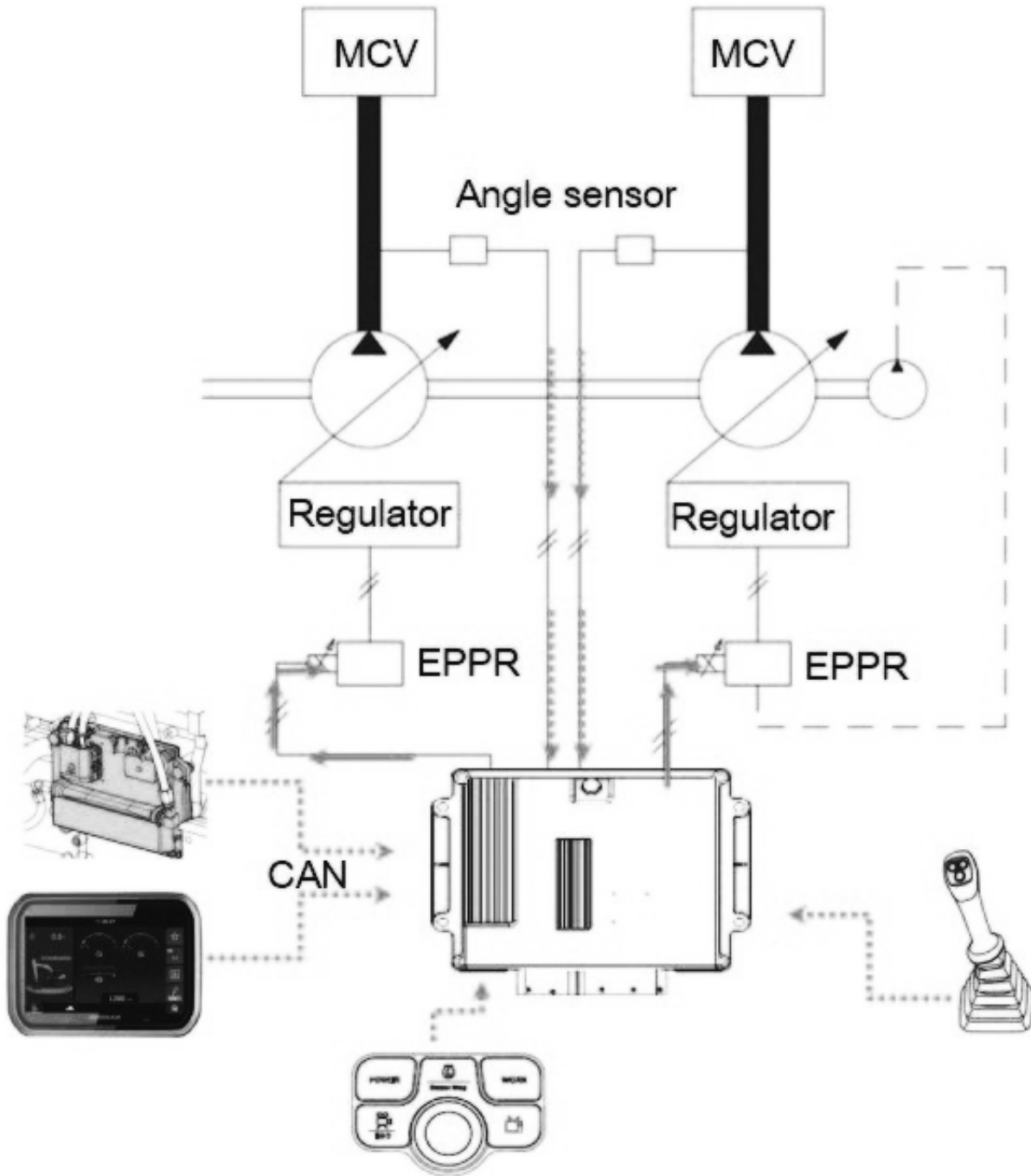

DS2101184

EPOS collects machine information from lots of sources, for example, Engine power, Monitor, Remote control lever pressures, Output flow amounts from the main pumps, etc.

And EPOS sends control signals to the EPPR valves on pump and engine for correct machine operation.

#### Flow Control Inputs

- Remote control lever pressures (Pilot pressure)
- Angle sensors (Feed back signal)
- Pump pressure and engine information

#### Flow Control Outputs

- EPPR signals on pump
- Bypass cut spools control on MCV
- Others

#### Pilot Pressure

EPOS measures pilot signals of the front attachment, travel and option operation through pilot pressure sensors which is mounted in the pilot lines from the remote control valves, so that EPOS can calculate the demand on the machine operation by the operator. It is a direct input signal into EPOS, which EPOS uses to control the machine operation, controlling various activations and output behavior. And it is one of important input signal to the EPOS for proper machine operation.

Figure 198

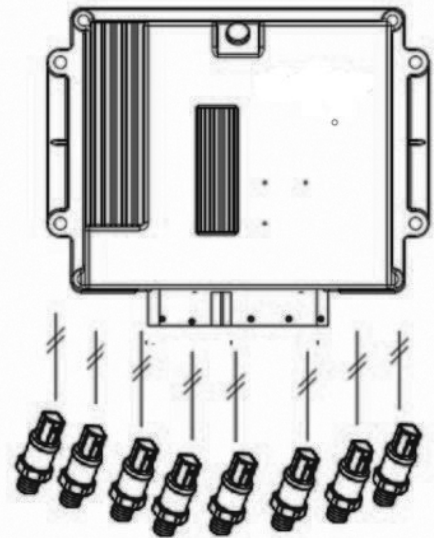

DS2101185

Figure 199

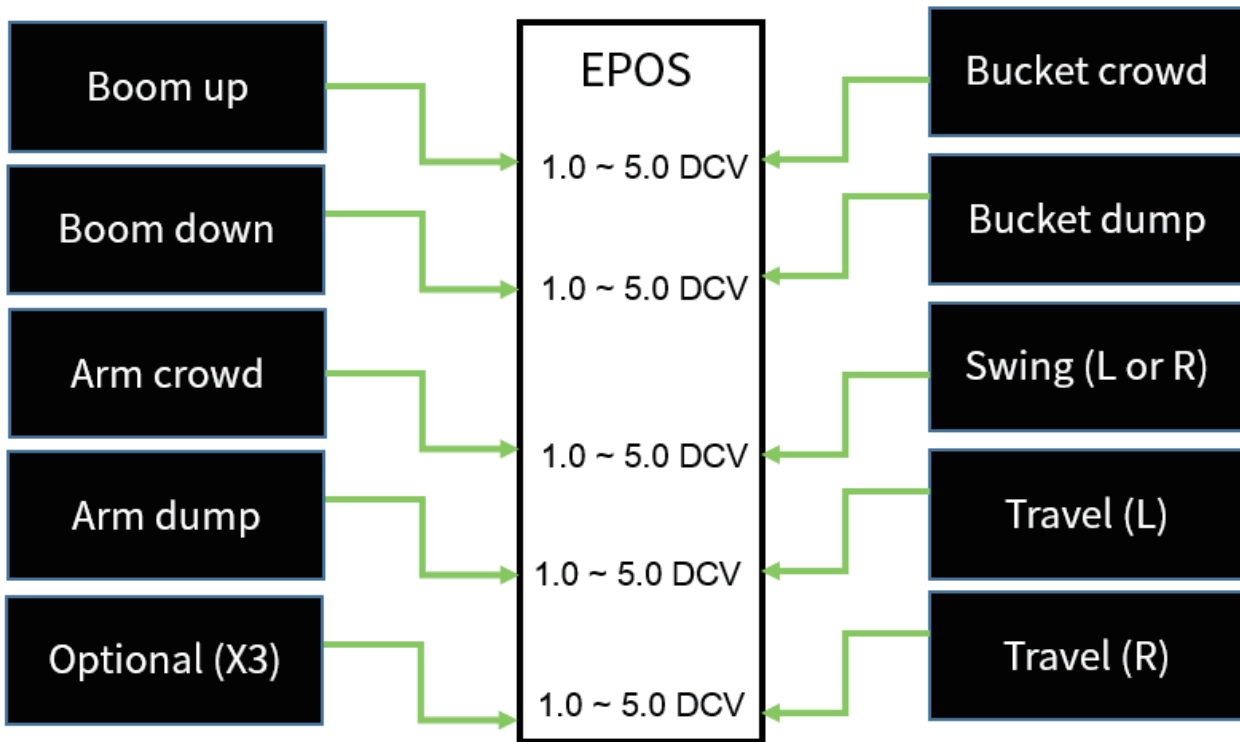

DS2101186

Based on the pilot input signals, EPOS determines the pump output flow for the main pumps, considering demands for cylinder speed, combined front operation and working load. If EPOS does not receive the proper input signals from the pilot pressure sensors, it gives a warning information to the operator and the possibility to enter a safe/emergency operating mode. Main spools on the main control valve can still be shifted by pilot pressure directly.

Figure 200

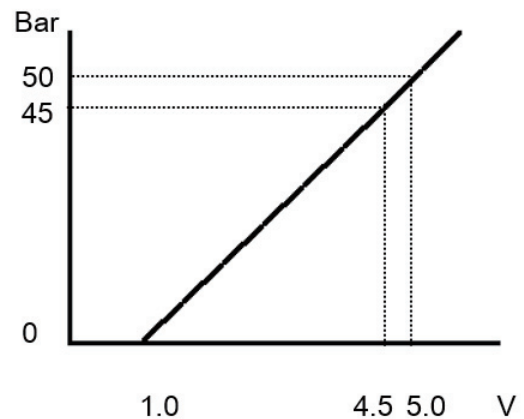
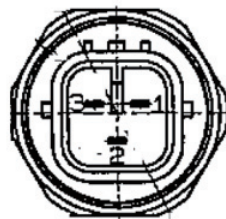

DS2101248

1	Power Supply
2	Output



3	Ground
---	--------

The output pressure and output voltage depends on the angle or motion of the joystick lever.

### EPPR Valve

Figure 201

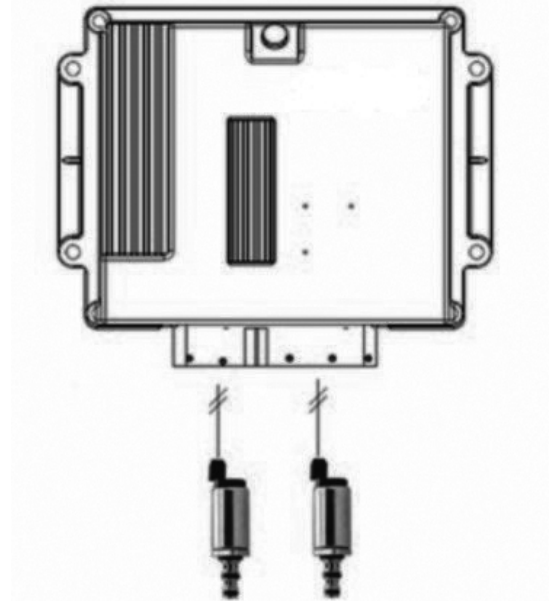

DS2101249

1	Power Supply
2	Output
3	Ground

The EPOS gives individual flow control signals to the EPPR valves which is mounted on the main pump to control their output flows to match the demanded oil flow from the system. The output flow is calculated from the engine speed and pump angle sensor signal and others. If EPOS does not give the correct signal to the main pump EPPR valves, the machine does not work and gives low machine performance. It is important to send the correct input signal to the EPOS for proper machine operation. And It is possible to enter an emergency mode by the operator manually selecting the auxiliary mode switches.

## Engine RPM Control

Figure 202

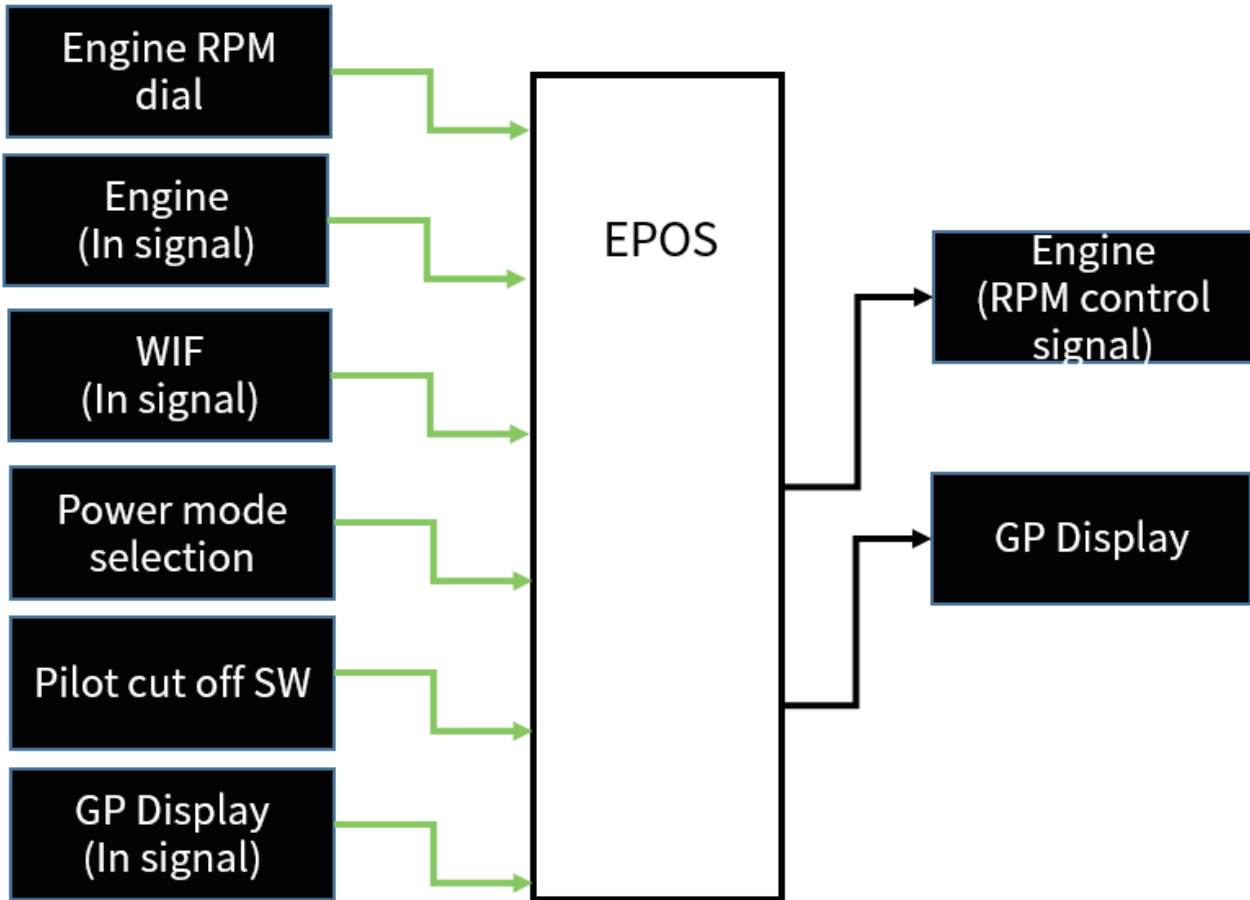

DS2101181

Engine RPM dial signal is connected to EPOS, the EPOS gives engine RPM command signal to engine (ECU). If Throttle dial is failed, the EPOS gives specific engine RPM command signal to engine (ECU) for emergency machine operation. Engine RPM will be restricted or controlled as below cases.

- Engine overheating
- Safety cut off position
- WIF warning
- Throttle dial failed
- Auto idle setting
- Power/work mode setting
- Auto idle setting

## Engine Shut-off Control

If the machine does not work or is idling for longtime, the engine will shutdown automatically. The shutdown can be

set by gauge panel by operator. Auto shut down does not work as below cases.

Figure 203

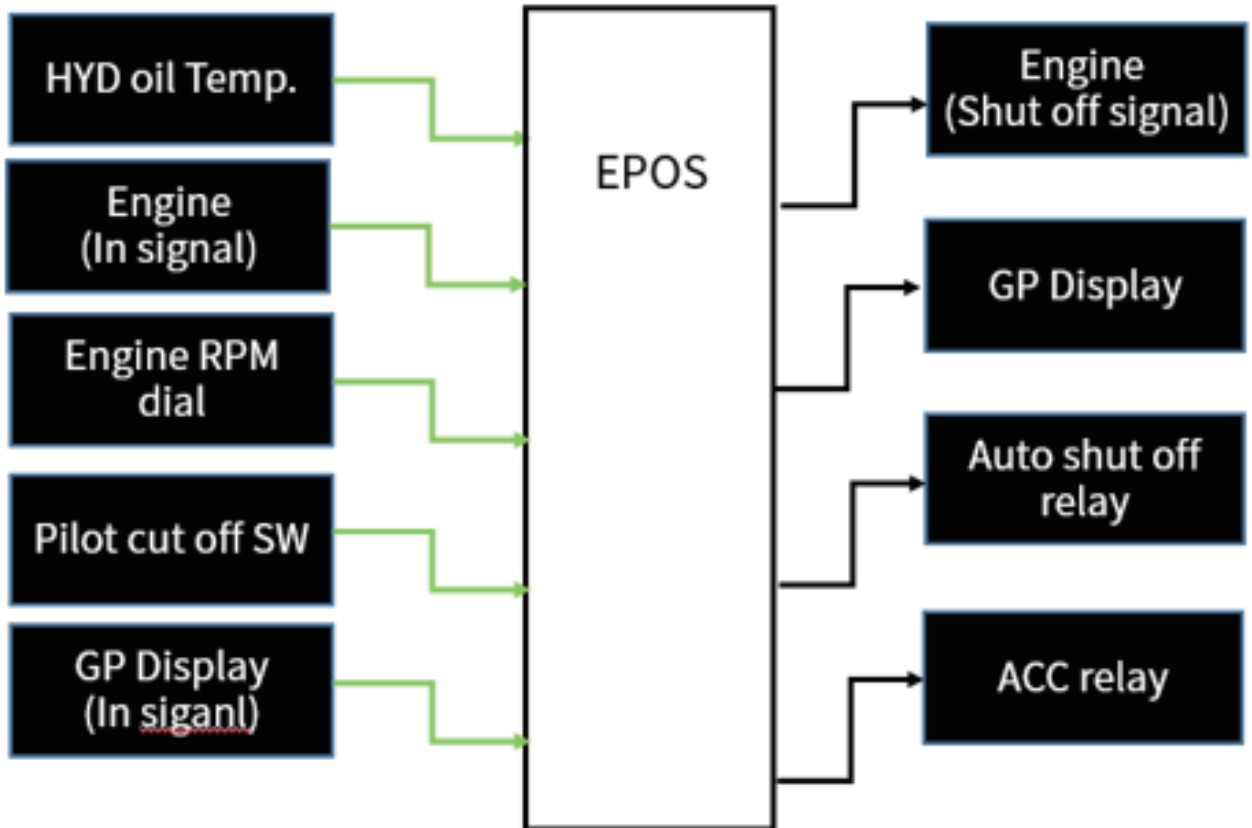

DS2101182

- Coolant Temperature is below 50°C
- HYD. oil temperature is below 30°C
- Pilot Cut off lever is up position
- Auto idle is not set
- Throttle dial is failed
- Engine does not run (below 10 RPM)

After engine shutdown, EPOS gives signal to auto shut off relay for disconnecting main power supply line by battery relay. But constant power supply line supplies power into fuse box and ACC relay works for below components. Auto shut off status is shown in the gauge panel.

- EPOS
- ECU
- Gauge panel display
- Smart Key Controller
- Others

## Hammer / Breaker Control

Figure 204

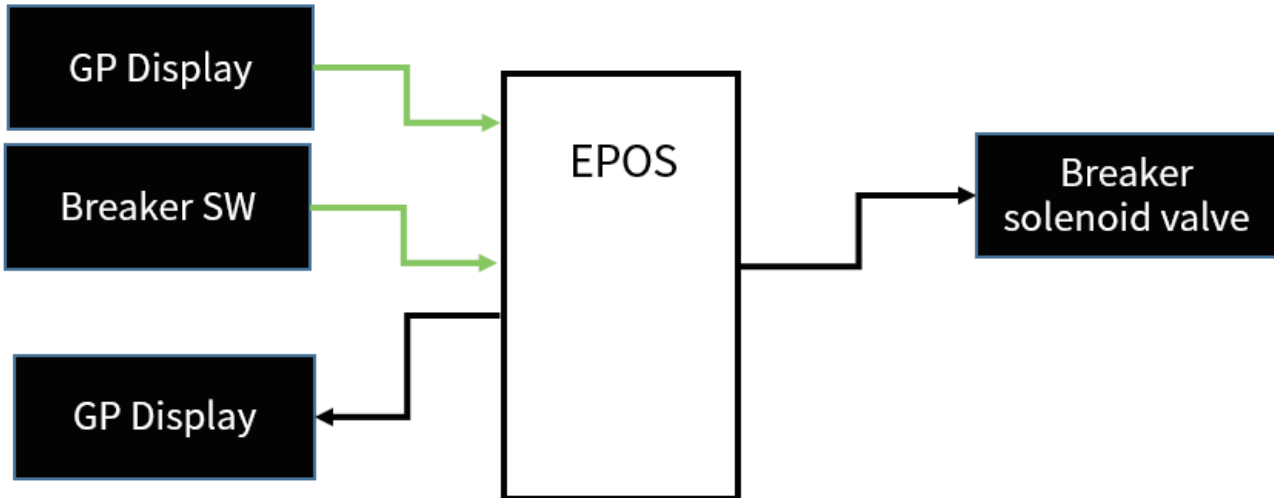

DS2101251

EPOS controls Hammer or Breaker operation with breaker solenoid valve, when operator set time, demanding oil amount or type of operating way, the EPOS controls Hammer or Breaker operation.

## Low / High and Auto Speed Control

Figure 205

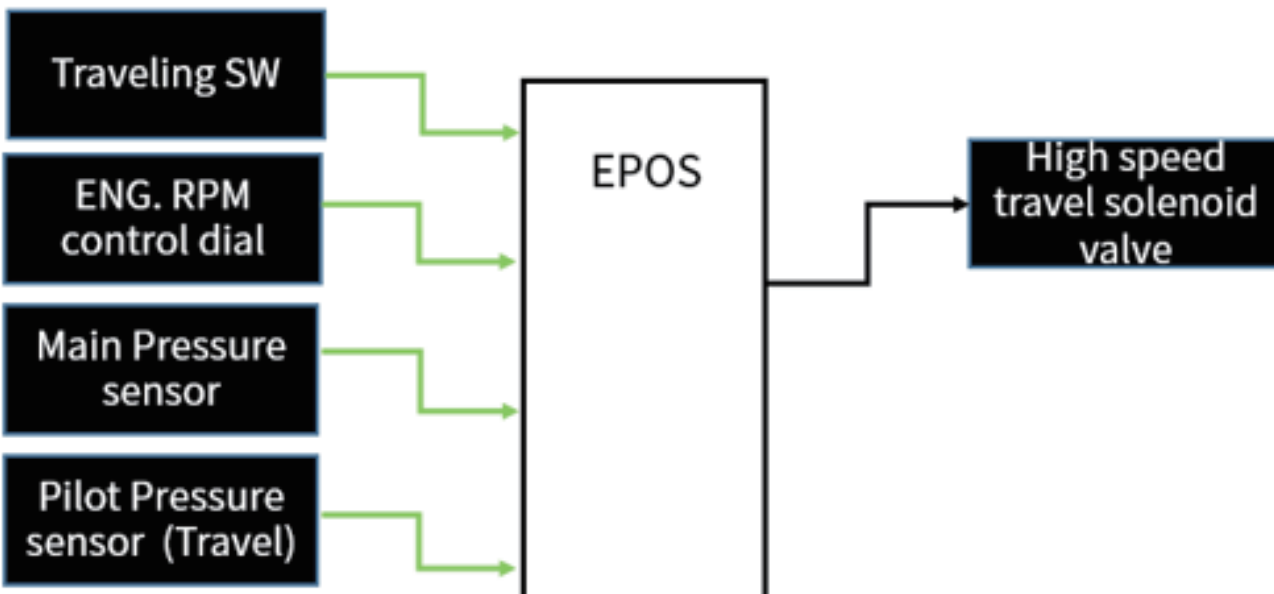

DS2101252

EPOS controls travel speed operation, activation of low, high or automatic speed.

**Low Speed**

- Set low travel speed switch ON
- Travel pilot pressure signal

**High Speed**

- Set high travel speed switch ON
- Throttle dial position (Below 2.5 V)
- Travel pilot pressure signal

**Auto Speed**

- Set auto travel speed switch ON
- Throttle dial position (Below 2.5 V)
- Pump pressure (Either one of pump pressure is over 294 bar)
- Travel pilot pressure signal

## OWD Control

Figure 206

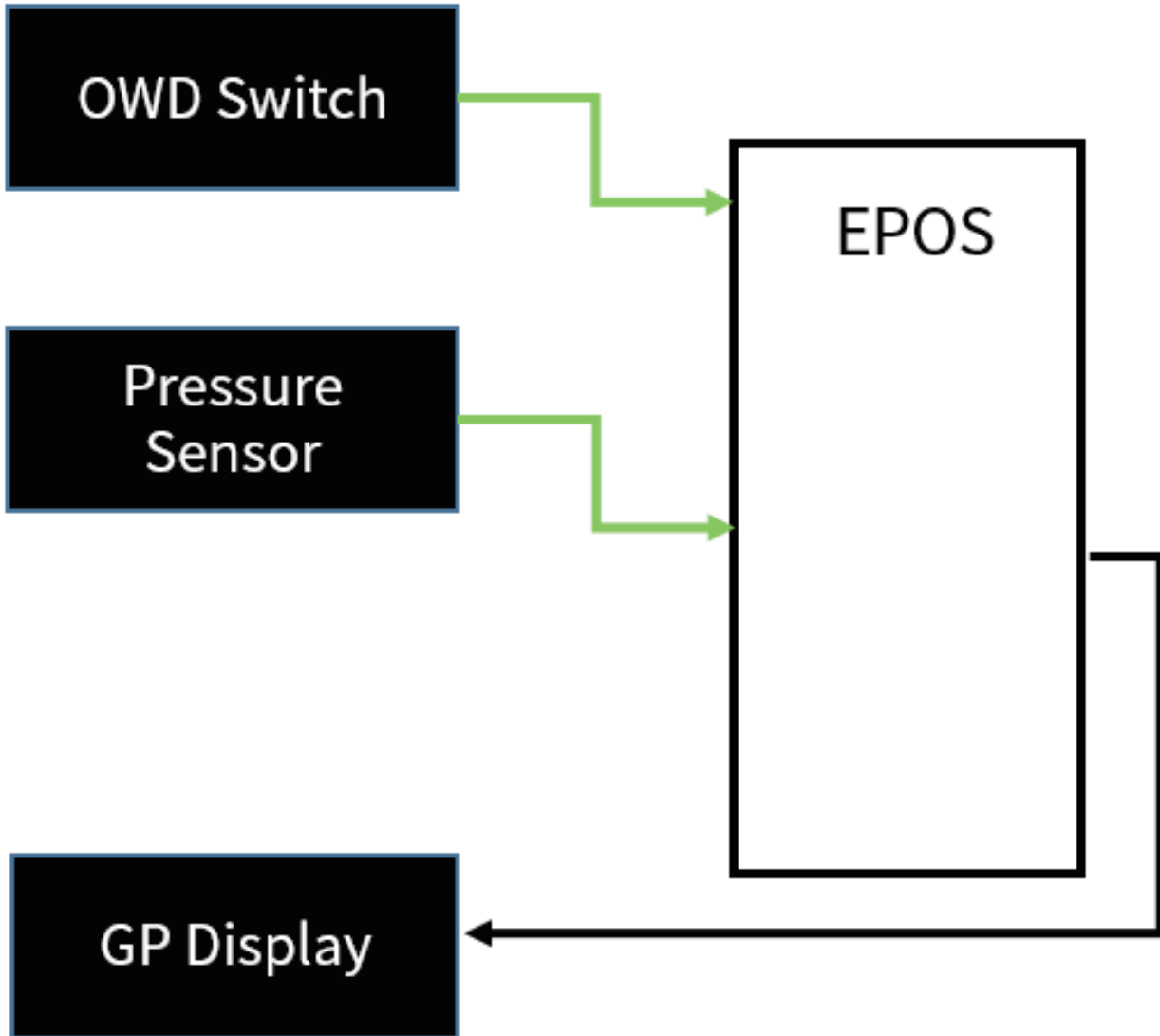

DS2101253

When the OWD function is activated, it warns the user if there is a risk of overturning the equipment based on the input value of the pressure sensor according to the pressure standard of the lateral conduction load of the equipment.

- Switch ON/OFF signal to EPOS
- Pressure of Boom Cylinder to EPOS
- When boom cylinder pressure reaches 90% based on 70% in Tipping Load, GP displays warning system and rings buzzer to operator.

# Seat Belt Control

Figure 207

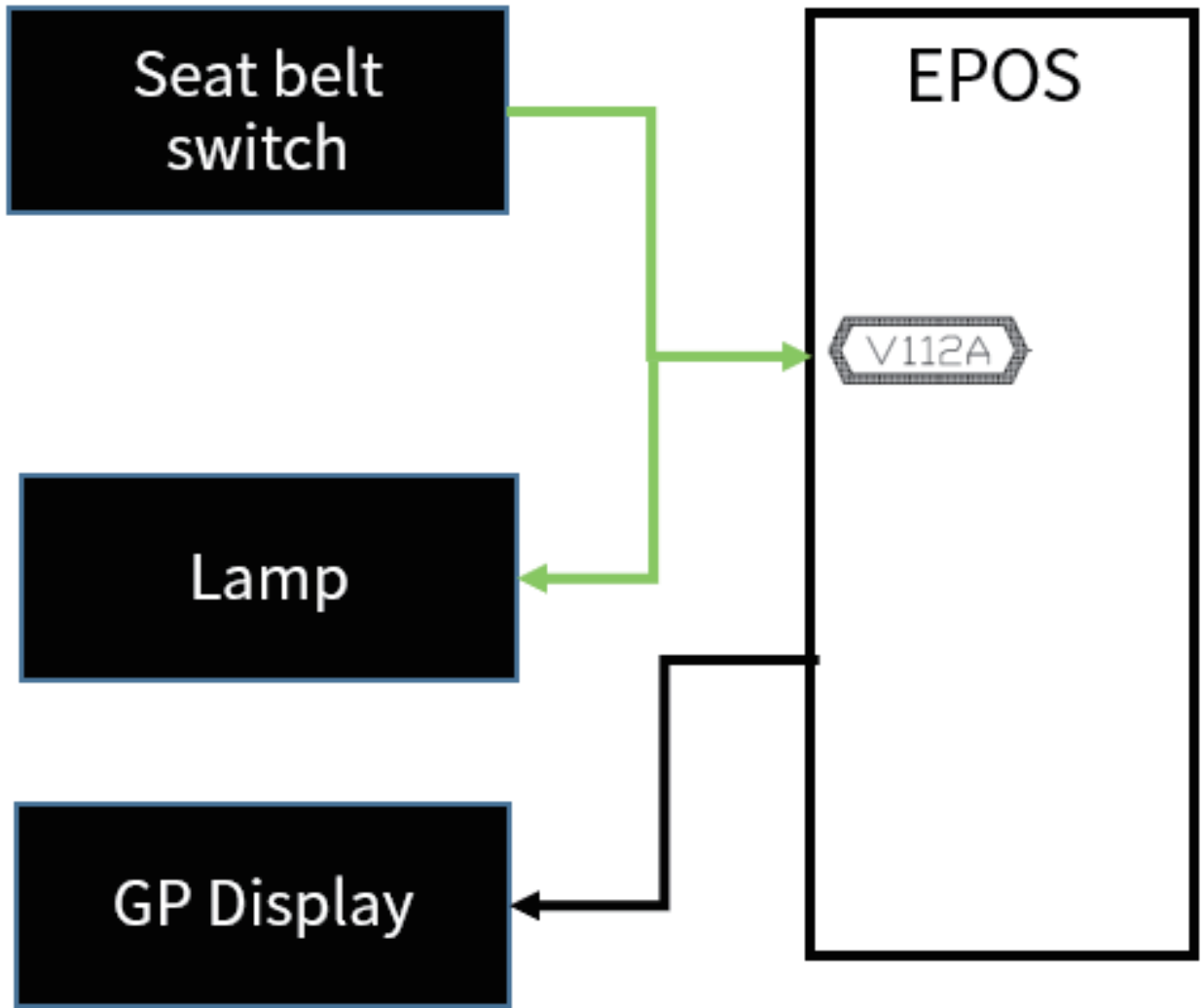

DS2101254

Seat belt is not fastened while machine operation, warning to operator through Gauge panel and indicating it at top of cabin outside.

## Quick Coupler Control

Figure 208

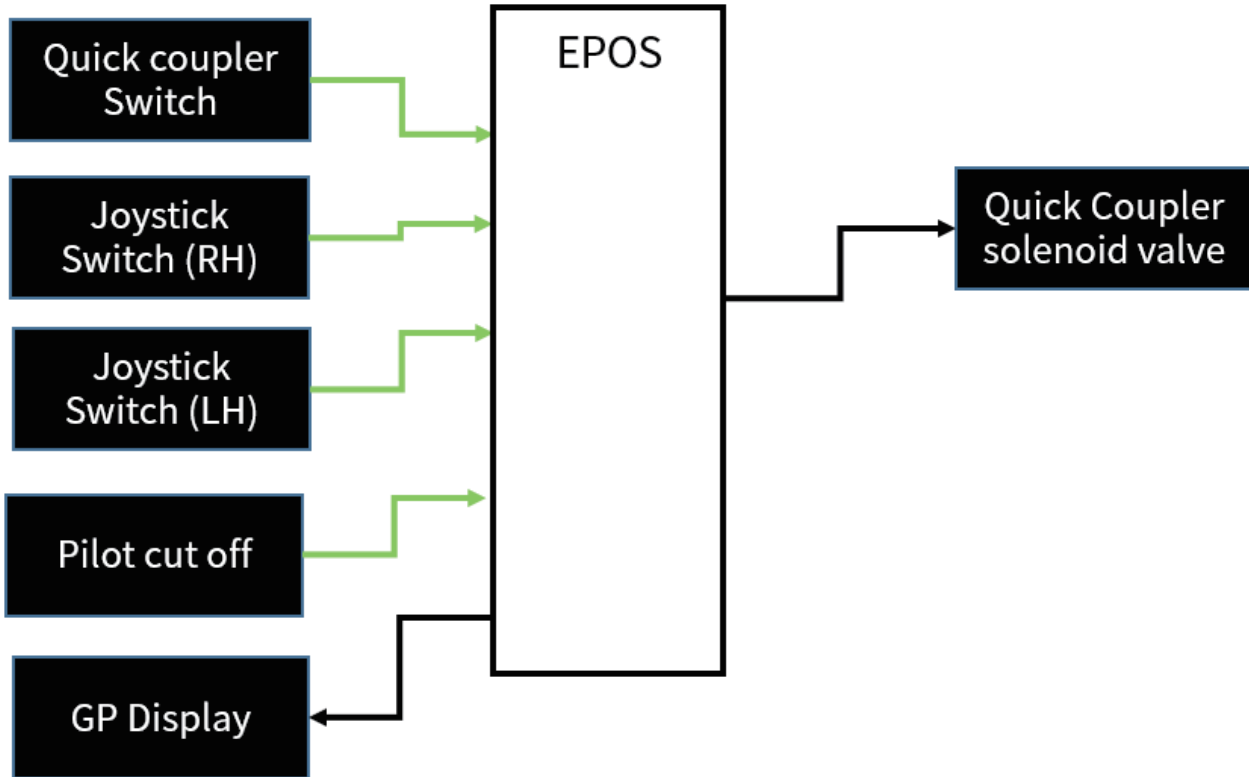

DS2101255

When EPOS gets signal from quick coupler switch, warning message is displayed and warning sound rings. And when depress open or close switch on left or right side joystick valve, the quick coupler solenoid is activated.



## Emergency mode of EPOS

Figure 209

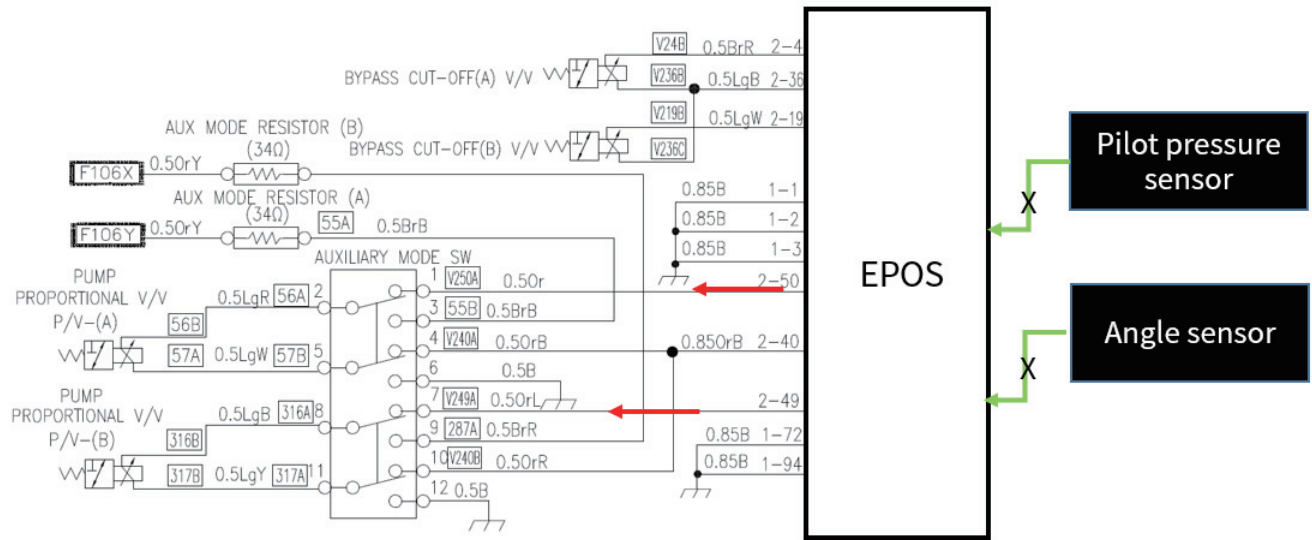

DS2101256

EPOS works properly but one of main input signal of pilot pressure sensors or angle sensors has serious failed, EPOS detects this failure situation and ask to operator for changing emergency mode on the monitor panel for emergency working. When operator accepts for emergency working on monitor, EPOS controls machine for emergency working.

## Auxiliary mode of EPOS

Figure 210

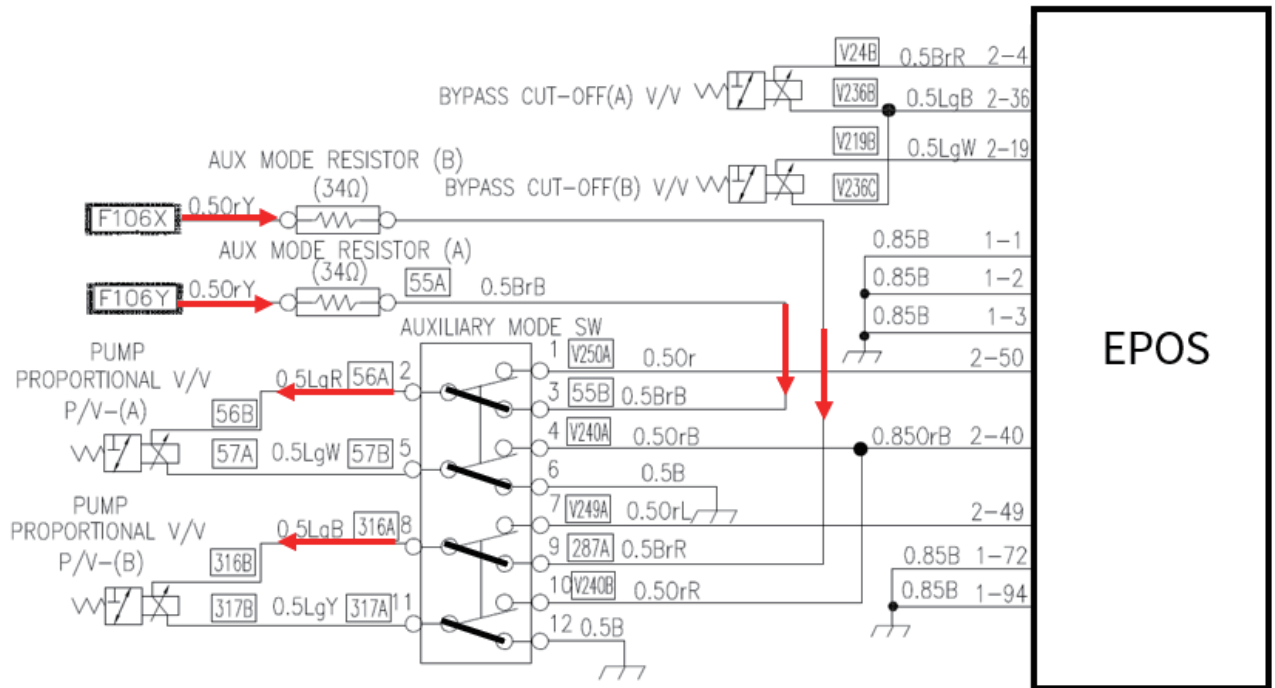

DS2101257

When EPOS has serious failed or trouble, the operator should select auxiliary mode for emergency machine operation as below circuit without EPOS controlling. The spool of MCV is shifted by pilot pressure direct and machine works for emergency operation only. It does not matter whether pilot pressure signal from joystick into EPOS.

## TMS (2.0)

EPOS collects key information of the equipment or controls the equipment through commands transmitted from the communication server.

Main collection information: location of equipment, total running time of engine, working time, fuel status, equipment warning / fault information, etc.

- Equipment control: RPM limit, engine restart limit
- Terminal H/W is divided into GSM only and dual mode

## Joystick Multi-function

This page is to set joystick one touch.

Setting of joystick one-touch function

1. Wiper
2. Intelligent floating boom temporary reset
3. Camera
4. Mute audio

\*Marking location of "joystick one-touch" function image is changed according to the two way option.

Figure 211

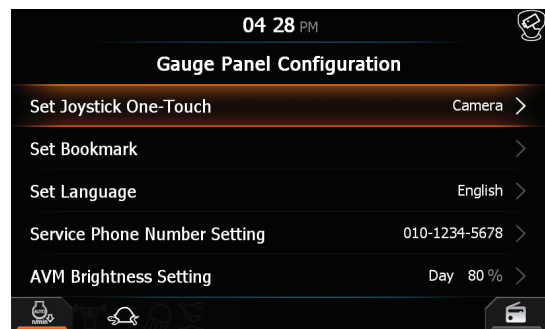

DS1901272

Figure 212

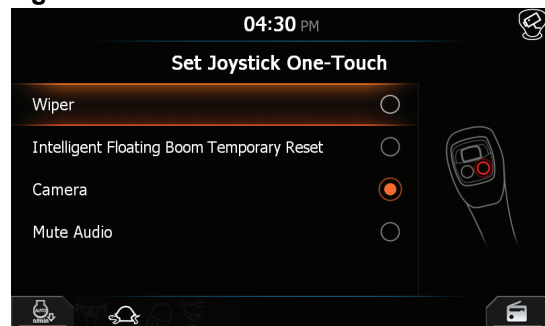

DS1900355

# Gauge Panel System

## Gauge Panel

### Connection Pin Detail

No.	Pin	No.	Pin
1	RS232_Rxd	13	Camera_PWR
2	RS232_Txd	14	Ext_VIN0A
3	RS232_Gnd	15	Ext_VIN1A
4	CAN1_H	16	Main_GND
5	CAN1_L	17	Main_GND
6	CAN2_H	18	Spare 1
7	CAN2_L	19	Ext_Buzzer
8	Ext. Lamp	20	Spare 3
9	BAT+	21	Spare 4
10	BAT+	22	Ext_V_GND
11	Key_Switch_ACC	23	Ext_V_GND
12	Key_Switch_Br		

Figure 213

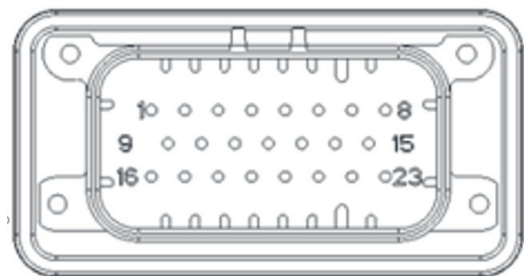

DS1901576

## Service Menu

### Overview

In this menu, many types of operating conditions and functions can be accessed and displayed.

This menu is mainly used for machine testing and fault diagnostics.

Various submenus can be selected by turning the jog switch and clicking on the jog switch to select the menu.

Press the ESC button to return to the previous screen.

**NOTE:** *The information, illustrations, and menu can change at any time without prior notice.*

Figure 214

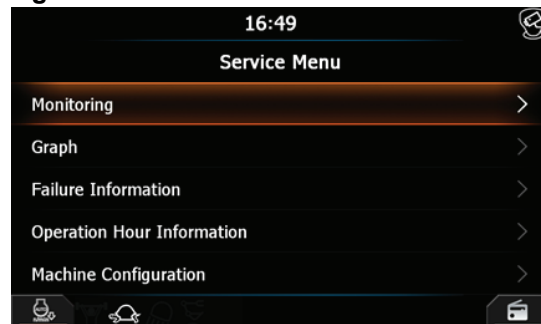

DS1901969

Menu Description				
1st	2nd	3rd	4th	5th
Service Menu	Monitoring	Vehicle Analog Input		
		Vehicle Analog Output		
		Vehicle Digital Input		
		Vehicle Digital Output		
		Engine Signal		
		User Selection Signal		
		TMS Information	GPS Information	
			Network Information	
			Terminal Information	
	Graph	Graph Data Monitoring		
		Set Graph Data		
	Failure Information	Real Time Failure Information		
		Failure Log Information		
		AVM Real Time Failure Information		
	Operation Hour Information			
	Machine Configuration	Option Configuration	Set Attachment Option	One Way
				Two Way
				Attachment Operating Option
				Option Pedal Type
				Rotating
				Ripper
				Tiltrotator
				Dozer
			Set Function Option	2D Machine Guidance
				3D Machine Guidance
				Machine Control
				Weighing
			Set Machine Option	Two-Pump
				Highland
				Intelligent Boom Float
				OWD
				Travel/Swing Alarm
				Quick Coupler
				RCW
				Mirror Heater
				Reverse Fan

				Arti-Boom
				Fuel Sensor (CAN Type)
				Joystick
			Set Machine Option (Wheeled machine only)	
			Set General Option	AVM
				Ultrasonic Sensor
				Outside Voice Alarm
				Boom Camera
				TMS
				Gateway
				Smart Key
				DAB
				OTA
				Keyless
		Set Camera	Set Camera1	
			Set Camera2	
		Version Information		
		Program Update		
		Enter Vehicle Name		
		Enter Serial Number		
		Reset	Failure Log Reset	
			Operation Hour Reset	
			Gauge Panel Configuration Reset	
		Calibration	Front Weight Calibration (if equipped)	
			Set AVM Tolerance Calibration	
			Tilt Sensor Calibration (if equipped)	
			Machine Guidance	Set Model Option
				Work Part Sensor
				Body Sensor
				Tilt Rotator Body Monitoring
			Machine Control	
			Weighing	
		Permanent Security Unlock		
		Gauge Panel Monitoring		

## Monitoring

1. Entering submenus: When cursor is located on "Monitoring" of special menu screen, press the jog switch and the "Monitoring" will be displayed.
2. The following menus can be accessed: Vehicle Analog, Vehicle Digital, Engine Signal, User Selection Signal and TMS Information.

Figure 215

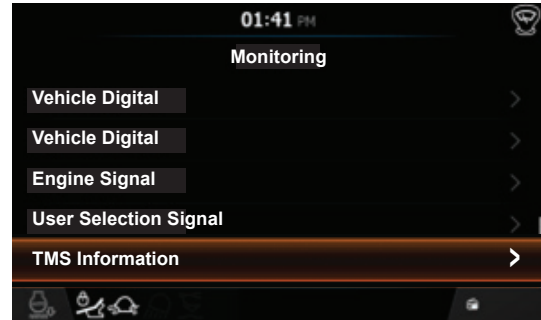
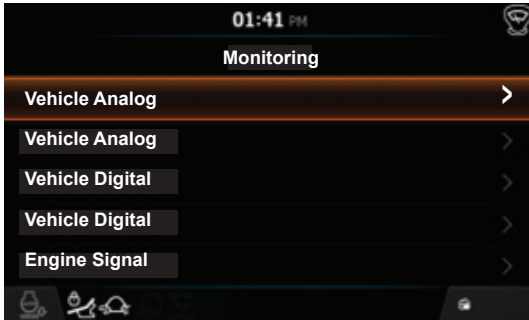

DS1901970

\* TMS Information is displayed only when TMS is activated in the option.

## Vehicle Analog

The following menus can be accessed: Front Pump Pressure, Rear Pump Pressure, Boom Cylinder Pressure, Reserved, Front Pump Angle Voltage, Power Shift P/V 1, Power Shift P/V 2, Coolant Fan Ctrl P/V, Flow Control P/V, 2-Way P/V (Open), 2-Way P/V (Close) and Rotating P/V(CW).

Figure 216

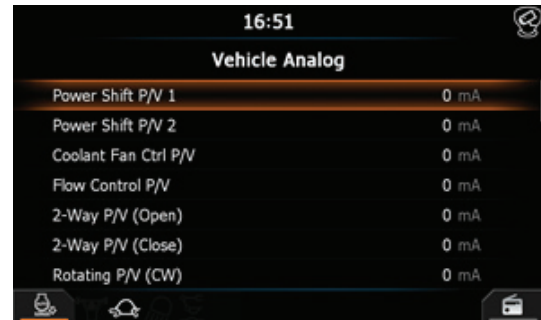

DS1901971

## Vehicle Digital

The following menus can be accessed: Alternator, Power Max Switch, One Way Operator Switch, Travel Select Switch, Hi-Speed Select Switch-M, Hi-Speed Select Switch-A, Working Lamp Switch, One Way S/V, Relief Pressure S/V, High Speed S/V, One Way Select S/V, Reverse Fan S/V, 2 Pump Select S/V and Cruise S/V.

**Figure 217**



DS1901972

**Engine Signal**

The following menus can be accessed: App Command, % Load at Current Speed, Engine Speed, ..... and DPF 1 Ash Load Percent.

**Figure 218**

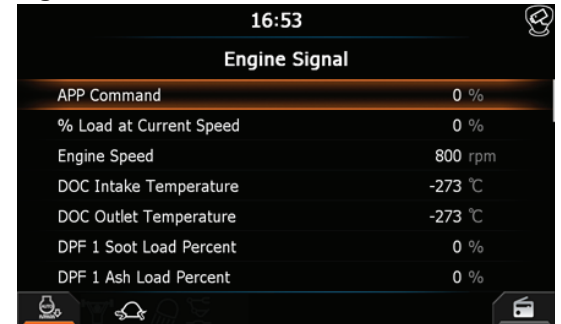

DS1901973

**User Selection Signal**

The following menus can be accessed: Front Pump Pressure, Rear Pump Pressure, Boom Cylinder Pressure, Fuel Level, WIF Sensor Voltage and etc.

1. Left side represents the monitoring item name and selection.

A. Monitoring item

- Vehicle analog input / output, vehicle digital input / output, and engine signal.

B. Selection

- The monitor displays the selected item status.

2. Right display unit is to display data in accordance with the monitoring unit selected in the left list.

A. Items that display monitoring item, data units are as follows:

- Vehicle analog input / output, engine signal

B. Items that display monitoring item, the activation is as follows:

- Vehicle digital input / output

3. Number where you can select the monitor is up to 8.

- If the current selection number is 8, adding another data will cause a popup.

**Figure 219**

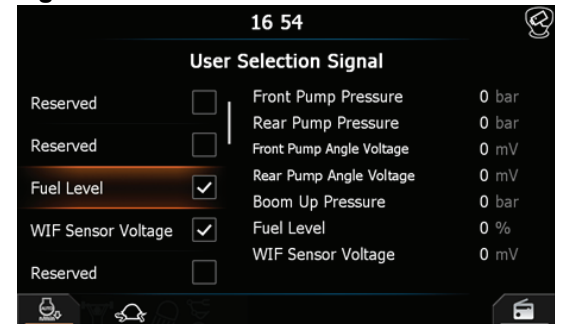

DS1901974

## TMS Information

### Overview

The following menus can be accessed: GPS Information, Network Information and Terminal Information.

Figure 220



DS1901975

## GPS Information

### Overview

In this screen, GPS Information can be monitored.

1. Items to display GPS Information are as follows.

A. Greenwich standard time

- 'dd/mm/yyyy hh:mm:ss +hh' formatted.

B. Latitude

- '0.000000 N/S' formatted.

C. Longitude

- '0.000000 E/W' formatted.

D. Altitude

- '00 m' formatted.

E. GPS Satellite number

- Displays the number of satellites used.

Figure 221

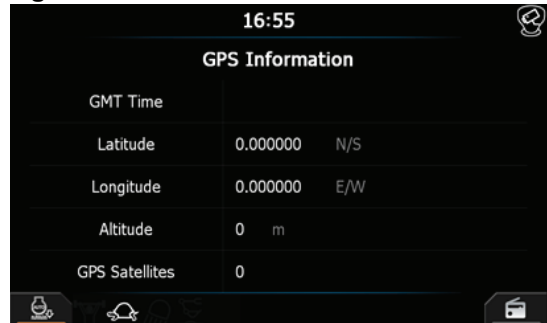

DS1902017

## Network Information

### Overview

In this screen, Network Information can be monitored.

1. The items to display the Network Information are as follows.

A. SIM ICCID: Displays SIM ICCID

B. GSM IMEI: Displays GSM IMEI

C. APN: Displays APN

D. Server Address: Displays server

E. Terminal Address: Displays terminal

F. Current Network: Displays current network

G. SIM Status: Displays SIM status "Connected" or "Not Connected"

H. GSM Type: Displays GSM type

I. GSM dBm: Displays GSM dBm

Figure 222

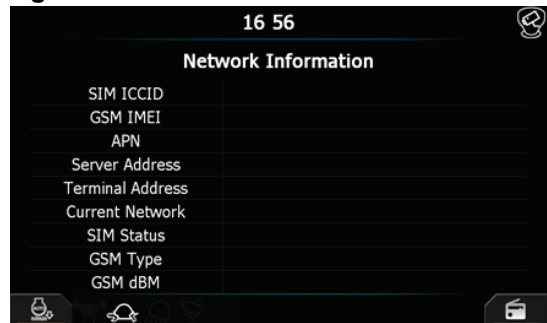

DS1901976



## Terminal Information

### Overview

In this screen, Terminal Information can be monitored.

1. The items to display the terminal information are as follows.
  - A. Serial Number: Displays serial number
  - B. Terminal Type: Displays terminal type
  - C. Serial Protocol: Displays serial protocol
  - D. Firmware Version: Displays firmware version
  - E. Software Version: Displays software version
  - F. DCF Version: Displays DCF version
  - G. Production Date: Displays production date
  - H. Internal Battery: Displays battery information

## Graph

### Overview

The following menus can be accessed: Graph Data Monitoring and Graph Data Setting.

## Graph Data Monitoring

### Overview

In this screen, the items selected in the graph data setting can be confirmed by a graph.

1. Left list unit is to display the monitored item name in the graph data set.
2. The right display shows the entire graph selected from the left, and the currently selected graph is displayed in bolder than the other graph. The graph display method is as follows.
  - A. X axis
    - On the time axis, display the time on the left and right for 18 seconds.
    - After 18 seconds, the minimum and maximum values of the x-axis are increased by 1 second, showing only 18 seconds.
  - B. Y axis
    - Data axis displays data for 18 seconds.
    - The y-axis maximum value indicates a specially determined value.

Figure 223

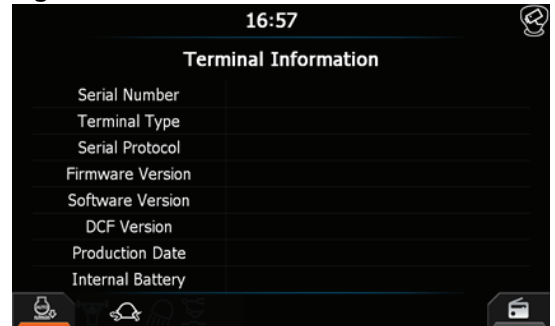

DS1901977

Figure 224



DS1901978

Figure 225

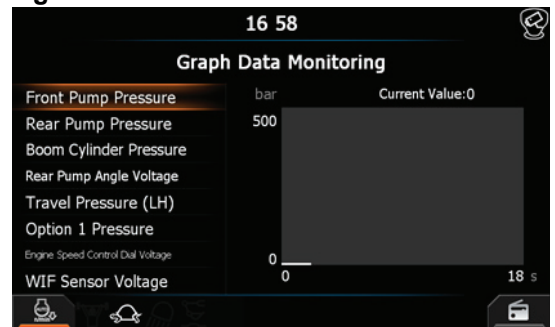

DS1901979

### C. Current Value

- Display the value of the corresponding data in real time.

## Graph Data Setting

### Overview

In this screen, it is possible to select data to check the graph in Graph Data Setting.

1. Items to select graph data are as follows.
  - Vehicle analog input / output, engine signal
2. Indicate whether to select graph data for each item.
3. Up to 8 graph data monitoring options can be selected.
  - If the current selection number is 8, adding other data causes a popup.

Figure 226

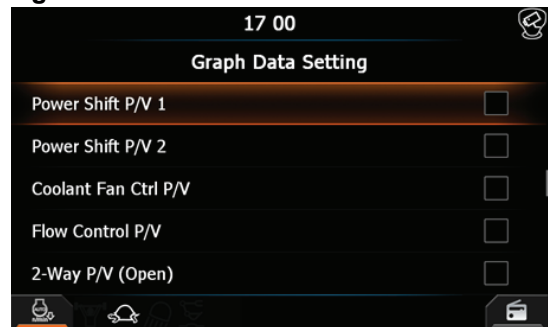

DS1901980

## Failure Information

### Overview

The following menus can be accessed: Real Time Failure Information, Failure Log Information and AVM Real Time Failure Information.

1. AVM Real Time Failure Information menu is displayed only when the AVM option is enabled.

Figure 227



DS1901981

## Real Time Failure Information

### Overview

In this screen, Real Time Failure Information can be monitored.

1. In the central list section, the fault sequence, fault code, and fault details are indicated as follows.
  - A. NO: Displays the order according to the error code priority.
  - B. CODE: Displays the error code.
    - Equipment error code: VXX (Prefix) + nnn (Priority) - nn (FMI)
    - Engine error code: E + nnnnnn (SPN) - nn (FMI)
  - C. Description: Displays detailed fault information.

Figure 228

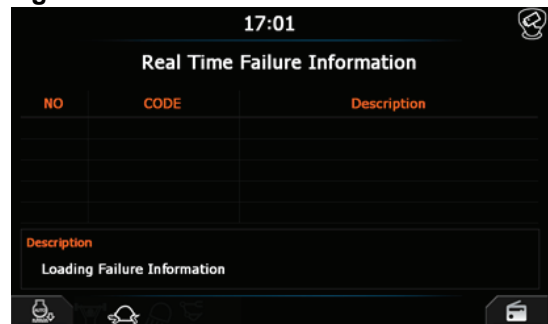

DS1901982

## Failure Log Information

### Overview

In this screen, Failure Log Information can be monitored.

1. In the central list section, the fault sequence, fault code, and fault details are indicated as follows.
  - A. NO: Displays the order according to the error code priority.
  - B. CODE: Displays the error code.
    - Equipment error code: VXX (Prefix) + nnn (Priority) - nn (FMI)
    - Engine error code: E + nnnnnn (SPN) - nn (FMI)
  - C. Number of occurrences: Displays the total number of times the corresponding fault occurred.
  - D. Occurrence Time: Indicates the operating time of the latest point where the corresponding fault occurred.

## AVM Real Time Failure Information

### Overview

In this screen, AVM Real Time Failure Information can be monitored.

1. In the central list section, the fault sequence, fault code, and fault details are indicated as follows.
  - A. NO: Displays the order according to the error code priority.
  - B. CODE: Displays the error code.
    - AVM error code: A + nnnnnn (SPN) - nn (FMI)
  - C. Description: Displays detailed fault information.

## Operation Hour Information

### Overview

In this screen, Operation Mode, Attachment, Hydraulic Oil Temp and Coolant Temp can be monitored.

Figure 229



Figure 230



Figure 231

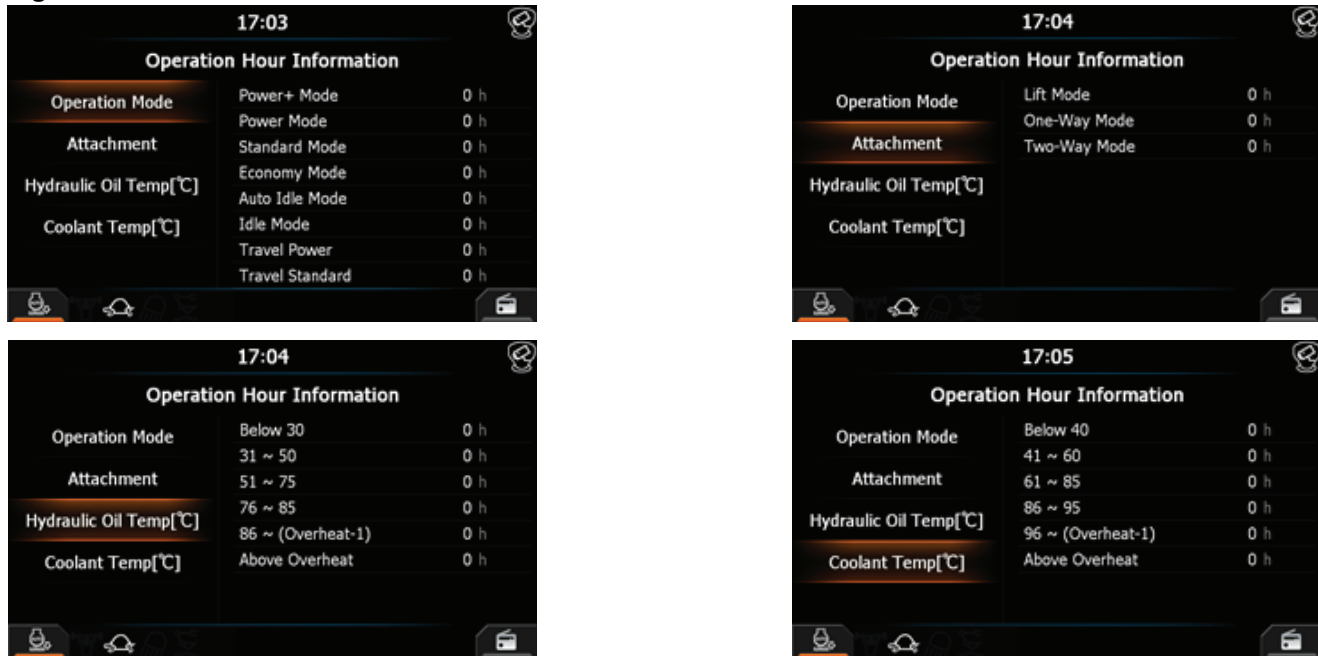

DS1901985

1. The left list shows the Operating Mode, Attachment, Operating Oil Temperature and Coolant Temperature.
2. The right side display shows the following items according to the left side list.
  - A. Operation Mode
    - Power + Mode, Power Mode, Standard Mode, Economy Mode, Auto Idle Mode, Idle Mode, Driving Power, Travel Standard
  - B. Attachment Mode
    - Lift Mode, Breaker Mode, Two Way Mode
  - C. Operating Oil Temperature
    - 30 or less, 31 ~ 50, 51 ~ 75, 76 ~ 85, 86 ~ (Overheat Temperature -1)
  - D. Cooling Water Temperature
    - 40 or less, 41 ~ 60, 61 ~ 85, 86 ~ 95, 96 ~ (Overheat Temperature -1)

## Machine Configuration

### Overview

The following menus can be accessed: Attachment Option Set, Machine Option Set, General Option Set, Program Update, Enter Serial Number, RESET, Version Information, Tolerance compensation setting, Emergency Code (TMS) and Permanent Unlock.

Figure 232

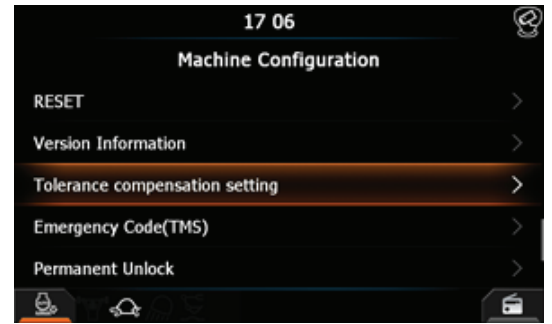
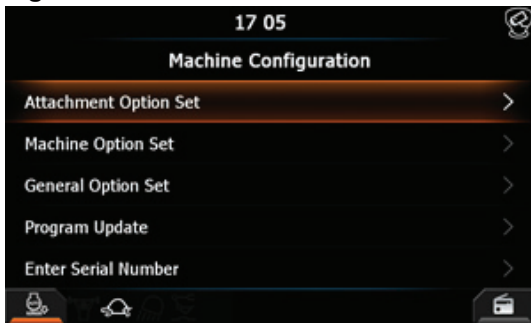

DS1901986

1. The following menu is displayed only in the case of the following right.
  - A. Camera setting, camera guideline tuning: AVM option setting disabled
  - B. Tolerance correction setting: Activate AVM option
  - C. Tilt sensor calibration: Wheel excavator
  - D. Disable temporary security, disable permanent security: Activate TMS option

### Attachment Option Set

#### Overview

The following menus can be accessed: Attachment Option, Attachment Operating Option, Option Pedal Type, Rotating Option, Ripper Option, Joystick Thumb wheel, Option Pedal and Joystick Thumbwheel + Option Pedal.

Figure 233



DS1901987

1. This screen is structured as shown above.
2. Indicates which option is used.

3. The following menu is displayed only in the case of the following right.
  - A. Attachment manipulation option: Two-way activation of attachment option
  - B. Optional pedal type: Activate pedal of attachment operation option
  - C. External voice warning option: Enable AVM option of option setting

## Attachment Option

### Overview

In this screen, attachment options can be set.

1. Indicates which attachment option is used. Attachment options are:
  - One Way (Breaker), Two Way

Figure 234

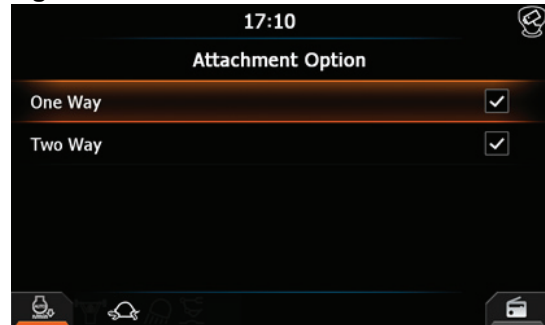

DS1901988

## Attachment Operating Option

### Overview

In this screen, the Attachment Operation Options can be set.

1. This screen is structured as shown above.
2. Indicates which attachment manipulation option is used. Attachment manipulation options are:
  - Joystick Thumbwheel, Optional Pedal, Joystick Thumbwheel + Optional Pedal

Figure 235



DS1901999

## Option Pedal Type

### Overview

In this screen, Option Pedal Type can be set.

1. Displays the current option setting.
2. The types of option pedals that can be set are as follows.
  - Hydraulic, Electric

Figure 236



DS1902000

## Camera Setting

### Overview

In this screen, it is possible to select the camera to set and then enter the Camera Setting screen.

Figure 237

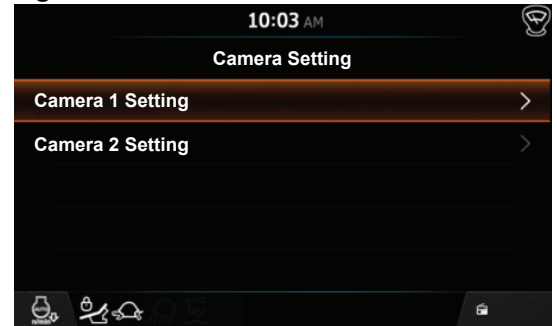

DS1902001

## SW Update

### Overview

In this screen, the instrument cluster SW can be upgraded.

1. The current version and the updated version are indicated as follows.

#### A. Current Version

- Displays the SW version currently installed in the instrument cluster
- Display in the format "V XXXX [yyyy.mm.dd]"

#### B. Update Version

- If the USB is connected and the instrument update file exists on the USB, the SW version on the connected USB is displayed in the format "V XXXX [yyyy.mm.dd]"
- If USB is connected and there is no instrument panel update file in USB, "No update file!" is displayed
- If there is no USB connection, "No USB storage device!" is displayed

2. The guidance text shall be marked as follows.

- "Please be careful when unplugging the USB or power off"

Figure 238

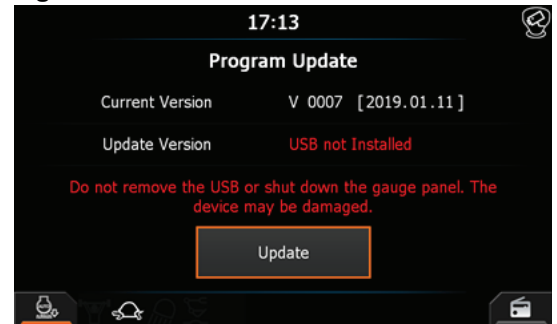

DS1902003

## Enter Serial Number

### Overview

On this screen, it is possible to enter the equipment serial number.

1. Display the serial number of the device being input.

Figure 239



DS1902004

## RESET

Figure 240



DS1902005

### Overview

In this screen, it is possible to enter Delete Failure Log, Reset Operating Hours and Reset Gauge Panel Settings.

Figure 241

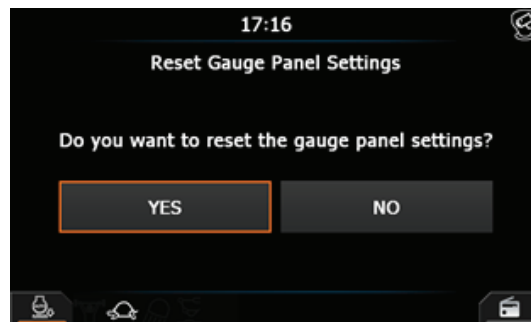
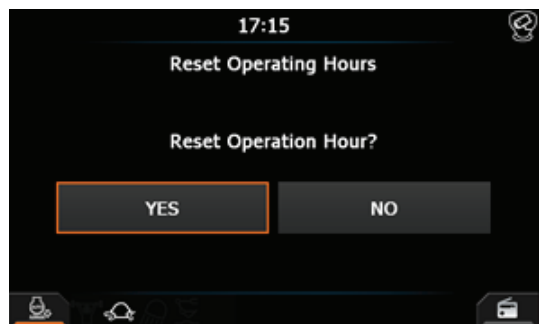
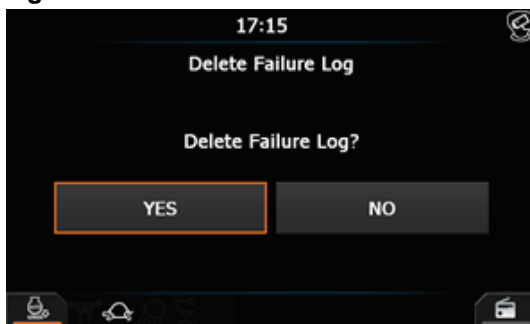

DS1902006

## Version Information

### Overview

In this screen, it is possible to check EPOS S/W Version, Gauge Panel S/W Version, Gauge Panel OS Version, ECU S/W Version and AVM S/W Version.

1. The version currently installed on the instrument panel is displayed. The display format is as follows.
  - Display in the format "V XXXX [yyyy.mm.dd]" (XXXX: 4 digits of the version number, yyyy.mm.dd: year of release, month, day)
2. AVM version display: Displayed when the AVM option is activated.

Figure 242



DS1902007



## Tolerance Compensation Setting

### Overview

In this screen, it is possible to enter Production plant Select, Initialize tolerance compensation, Tolerance compensation execution and Apply tolerance compensation.

Figure 243



DS1902008

## Production Plant Select

### Overview

In this screen, the producer can be selected.

1. It displays the currently set producer.
2. The producers to choose from are as follows.
  - Factory 1, Factory 2, Factory 3, Factory 4

Figure 244



DS1902009

## Initialize Tolerance Compensation

### Overview

In this screen, it is possible to initialize the tolerance compensation.

1. This screen is composed of a button for selecting to initialize the tolerance correction setting.

Figure 245

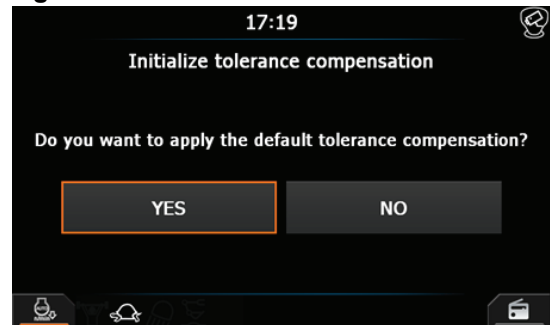

DS1902010

## Tolerance Compensation Execution

### Overview

This screen is for performing tolerance correction.

1. This screen is composed of the tolerance correction execution selection button as shown in the right figure.

Figure 246

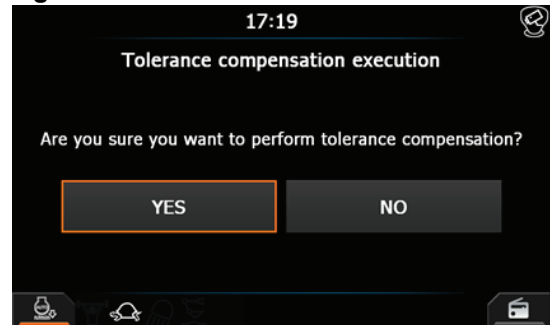

DS1902011

## Apply Tolerance Compensation

### Overview

This screen is for applying tolerance correction.

Figure 247

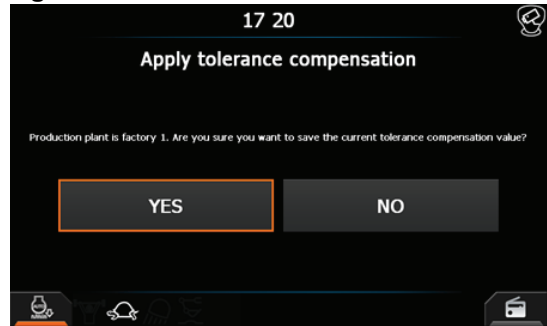

DS1902012

## Emergency Code (TMS)

### Overview

This screen is for unlocking the authorized personnel by inputting the code through the instrument panel (Ignition Lock or RPM Limitation) locked by the TMS server and the TMS terminal is in the shaded area and cannot receive the release command.

Figure 248



DS1902013

## Permanent Unlock

### Overview

This screen is unlocking the authorized personnel by inputting the code through the instrument panel (Ignition Lock or RPM Limitation) locked by the TMS server and the TMS terminal is in the shaded area and cannot receive the release command.

1. This screen is composed of a display part and an input keypad as shown in the right figure.
2. Display
  - Current password: Displays the current password.
  - Security Code: Displays the 8-digit release code received from EPOS.

You can get your password off with the security code.

Figure 249

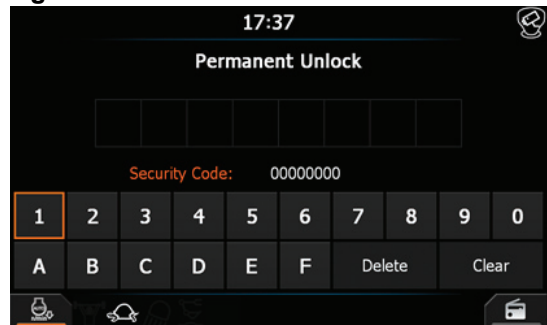

DS1902014

## Enter The Equipment Name

### Overview

In this screen, the device name can be set by inputting with English keypad.

1. On the left side, the name of the currently input equipment is displayed.
2. On the right side, the name of the device being input is displayed.

Figure 250

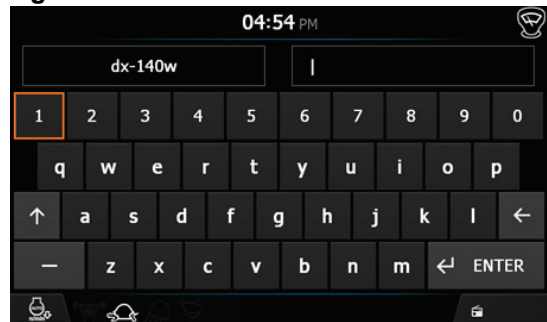

DS1902015

## Miscellaneous

### Audio Display

#### Overview

In this screen, audio can be set.

Figure 251

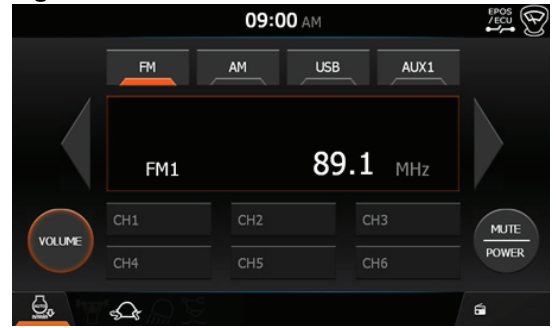

DS1902016

# Removal and Installation



# Removal and Installation



# Engine



# Safety Instructions

---

## **WARNING**

---

### AVOID DEATH OR SERIOUS INJURY

Instructions are necessary before operating or servicing machine. Read and understand the Operation & Maintenance Manual and signs (decals) on machine. Follow warnings and instructions in the manuals when making repairs, adjustments or servicing. Check for correct function after adjustments repairs or service. Untrained operators and failure to follow instructions can cause death or serious injury.

---

# Table of Contents

## Engine

Safety Instructions .....	6
Before Removing And Installing .....	8
Preparatory Work .....	8
General Precaution .....	8
Completing Work .....	8
ECU (Engine Control Unit) .....	9
Repair Procedure Quick Guide .....	9
Removal .....	9
Installation .....	11
V-Belt.....	12
Repair Procedure Quick Guide .....	12
Removal .....	12
Installation .....	13
Alternator .....	14
Repair Procedure Quick Guide .....	14
Removal .....	14
Installation .....	15
Starter Motor .....	16
Repair Procedure Quick Guide .....	16
Removal .....	16
Installation .....	17
DEF (adblue®) Quality Sensor.....	18
Repair Procedure Quick Guide .....	18
Removal .....	18
Installation .....	22
Sensors - After Treatment .....	23
Repair Procedure Quick Guide .....	23
Removal .....	23
Installation .....	25

# Before Removing And Installing

## Preparatory Work

1. Park the machine on level ground. And lower front attachment to the ground.
2. Set parking brake switch to the parking position and then stop the engine.
3. Support the wheel chock to tire.
4. Move safety lever to "LOCK" position and then stop the engine.
5. Turn battery disconnect switch to "OFF" position.
6. Release the remaining pressure in the hydraulic circuit.
7. Cool down the hydraulic system and engine.
8. Attach a maintenance warning tag on controls.

Figure 1

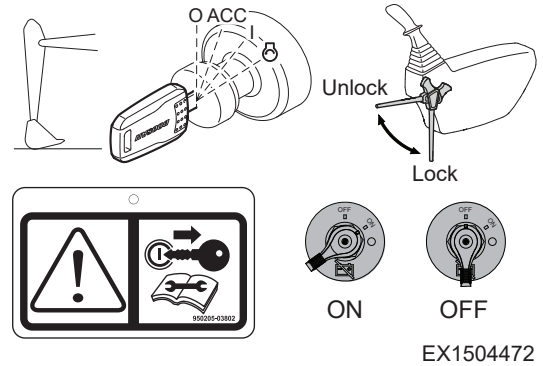

## General Precaution

1. Always read the safety section before removing and installing.
2. Mark the location of the bolts before removing.
3. Keep in the mind the order for tightening bolts.
4. Tighten bolts by hands, then using the tool.
5. If reusing the bolts, clean threads and apply thread locker to threads prior to installation.
6. Mark the location of wire harness connectors and hoses before disconnecting.
7. Be careful not to damage all components.
8. Do not reuse gaskets, O-ring and adhesive bolts.

Figure 2

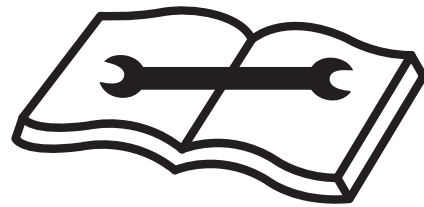

DS1901903

## Completing Work

1. Check oil, coolant and fuel leak from the machine.
2. Check all oil level and if necessary, add oil.
3. Fill up the fuel tank to the standard level.
4. Apply grease to all lubrication points.
5. When fuel component has been disconnected, air must be bled from circuit.
6. When hydraulic component has been disconnected, air must be bled from circuit.
7. Start the engine and run at low idle for about 5 minutes.
8. Perform the machine performance test.

# ECU (Engine Control Unit)

## Repair Procedure Quick Guide

- Step-A. Remove right side cover
- Step-B. Remove bracket
- Step-C. Disconnect wiring harness
- Step-D. Remove ECU assembly

## Removal

### Side Cover

1. Turn OFF the battery disconnect switch.
2. Remove the right side door.

Figure 3



DS2105469

### Bracket

1. Remove mounting bolts (1) and bracket (2).

**NOTE:** Do not tighten the fasteners too hard when installing.

Figure 4

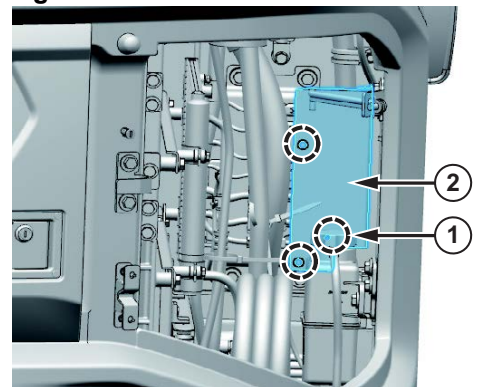

DS2105470

2. Disconnect wire harness connectors (1) from bracket.

**Figure 5**

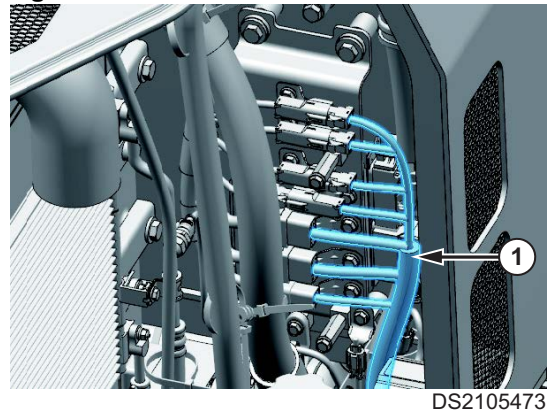

### Wiring Harness

1. Disconnect harnesses (1) from ECU.

**NOTE:** Check the location of the connectors before disconnecting. Be careful not to let water get into electrical components. If water gets into electrical system, this will cause an electrical short circuit and result in improper machine operation.

**Figure 6**

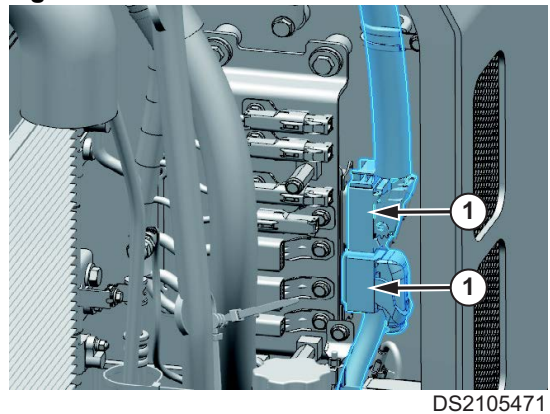

### ECU Assembly

1. Remove mounting bolts (1) and separate bracket (2).

**NOTE:** Do not tighten the fasteners too hard when installing.

**Figure 7**

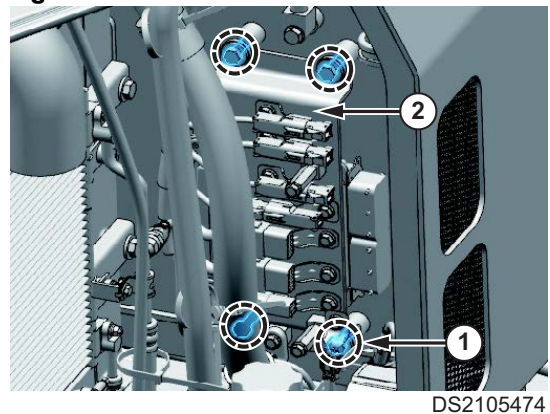

2. Remove mounting bolts (1) and ECU assembly (2) from bracket.

**NOTE:** *Do not tighten the fasteners too hard when installing.*

### Installation

1. Perform installation in the reverse order to removal.

**Figure 8**

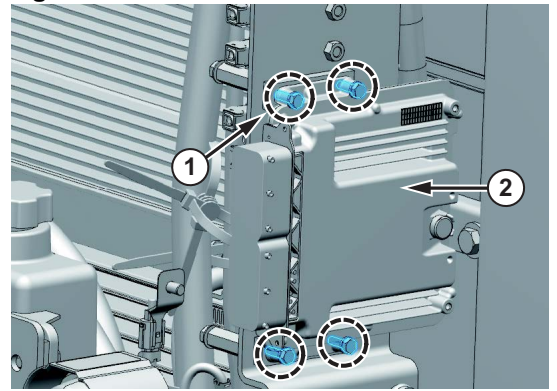

DS2105472

# V-Belt

## Repair Procedure Quick Guide

Step-A. Remove engine hood

Step-B. Disconnect engine air hose

Step-C. Remove V-belt

## Removal

1. Turn OFF the battery disconnect switch.
2. Open the engine cover.

Figure 9

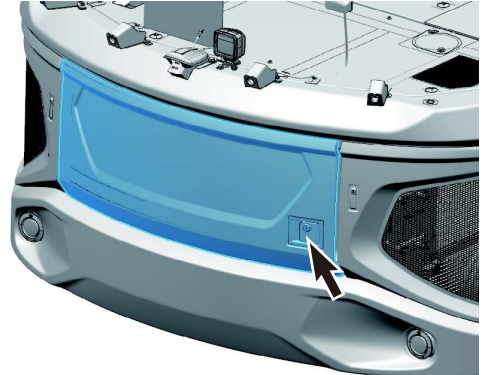

DS2105468

## Undercover

1. Remove the undercover (F).

For details, refer to [Undercovers - Removal and Installation](#).

Figure 10

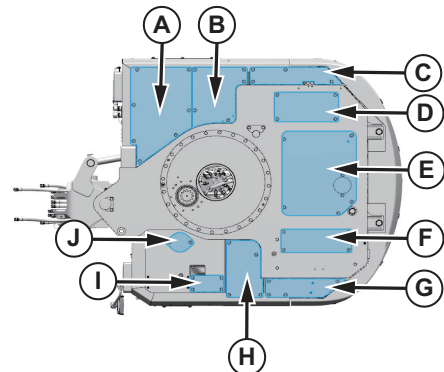

DS2105465

## Engine Hood

1. Remove mounting bolts (1) and top cover (2).

- Tool: 19 mm (  )
- Torque: 107.8 N.m (11 kg.m, 79.5 ft lb)
- Weight: about 25 kg (55.1 lb)

Figure 11



DS2105558

## Engine Air Hose

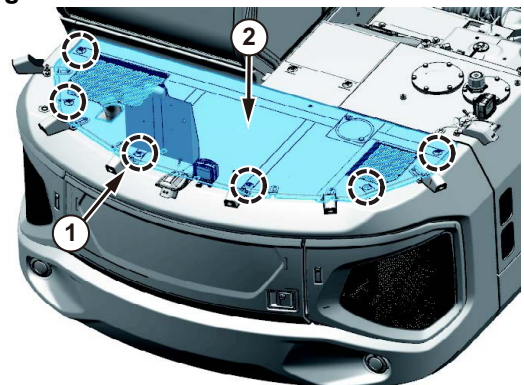
1. Loosen the clamp bolts from the air hose.
2. Disconnect air hoses (1, 2).

Figure 12

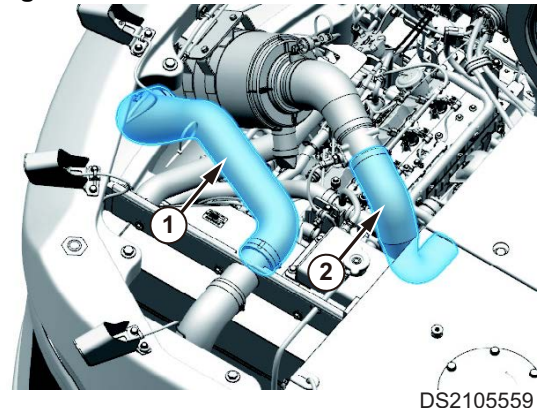

## V-Belt

1. Insert the tool into the auto tensioner bolt (1).

- Tool: 17 mm (  )

**NOTE:** Before removing the belt, check the belt layout.

2. Turn the auto tensioner with tool counterclockwise to loosen and put away the V-belt (2).

**NOTE:** If reusing V-belt, mark the rotation direction on the belt.

3. Carefully release the tension.
4. Remove tool from auto tensioner bolt.

Figure 13

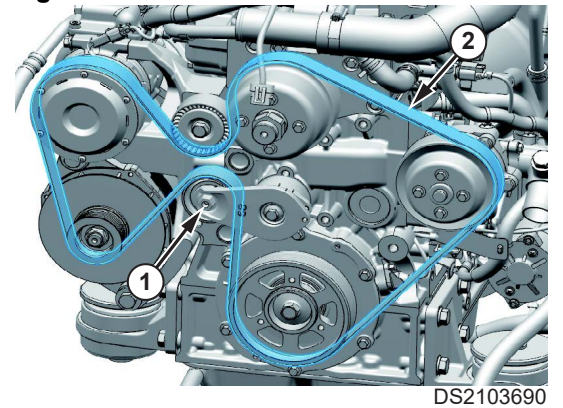

## Installation

1. Perform installation in the reverse order to removal.
2. Check that V-belt is installed to the all pulley grooves.
3. Start engine.



# Alternator

## Repair Procedure Quick Guide

Step-A. Open the engine cover

Step-C. Loosen the V-belt

Step-D. Disconnect wiring harness

Step-E. Remove alternator assembly

## Removal

1. Turn OFF the battery disconnect switch.
2. Open the engine cover.

Figure 14

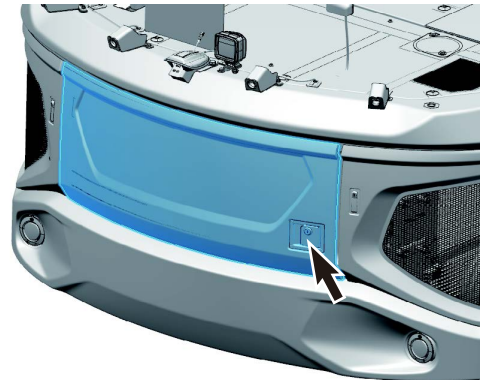

DS2105468

## V-Belt

1. Insert the tool into the auto tensioner bolt (1).

- Tool: 17 mm (  )

**NOTE:** Before removing the belt, check the belt layout.

2. Turn the auto tensioner with tool counterclockwise to loosen the V-belt (2).

**NOTE:** Do not remove the V-belt from the pulley other than the alternator pulley.

3. Carefully release the tension.
4. Remove tool from auto tensioner bolt.

Figure 15

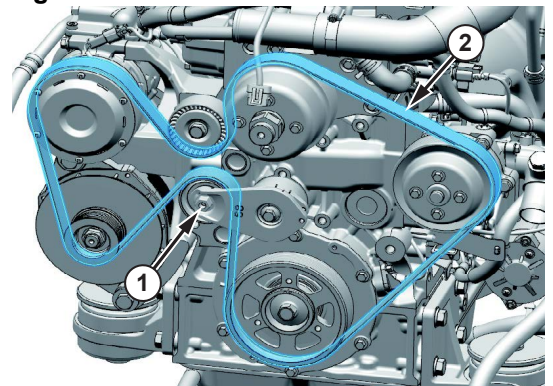

DS2103690

## Wiring Harness

1. Remove the nut and disconnect cable (1).
2. Disconnect wire harness connector (2) from alternator.

Figure 16

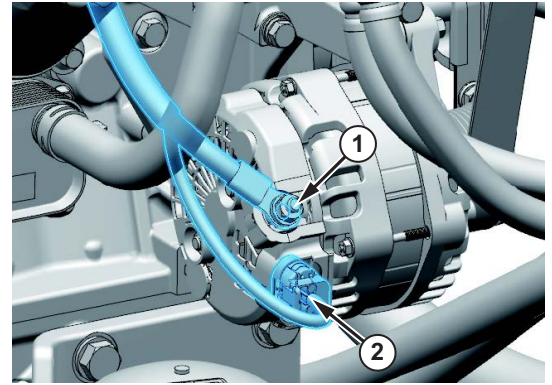

DS2105556

## Alternator Assembly

1. Remove the mounting bolts (1, 2) from alternator.
2. Remove the alternator (3) from engine assembly.

## Installation

1. Perform installation in the reverse order to removal.
2. Start engine.

Figure 17

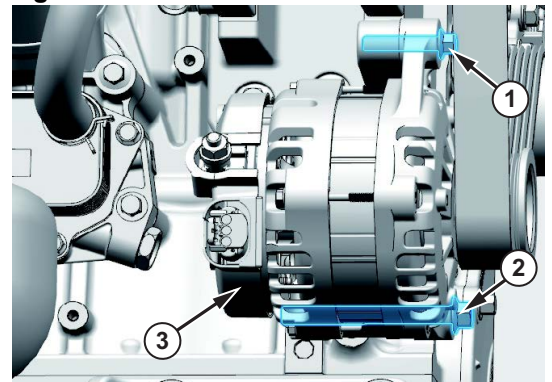

DS2105557

# Starter Motor

## Repair Procedure Quick Guide

Step-A. Remove undercover

Step-B. Disconnect cable

Step-C. Remove starter motor

## Removal

1. Turn OFF the battery disconnect switch.
2. Open the engine cover.

Figure 18

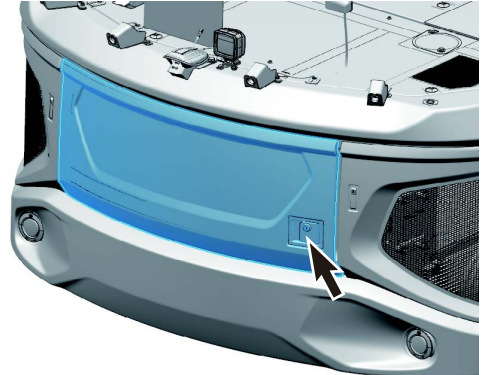

DS2105468

## Undercover

1. Remove the undercover (E).  
For details, refer to [Undercovers - Removal and Installation](#).

Figure 19

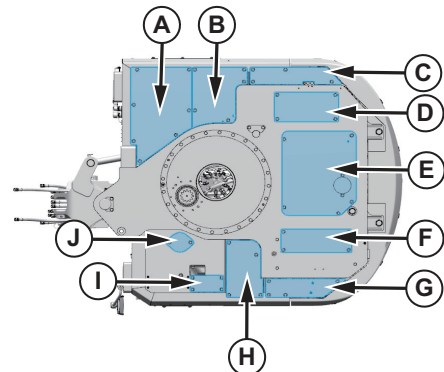

DS2105465

## Cable



1. Disconnect wire harness connector (1) from starter motor.
  - Tool: 8 mm ()
2. Disconnect the positive cable (2) from starter motor.
3. Remove mounting bolt and ground cable (3).
  - Tool: 14 mm ()

Figure 20



DS2105466

### Starter Motor

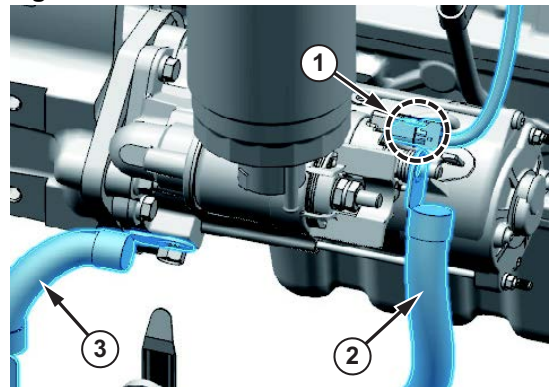
1. Remove upper mounting bolts (1) from starter motor.
2. Remove lower mounting bolts (1) from starter motor.
3. Remove starter motor (2).

- Tool: 14 mm (  )

### Installation

1. Perform installation in the reverse order to removal.
2. Start engine.

**Figure 21**

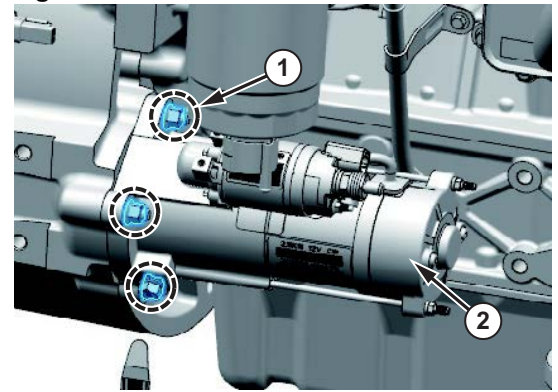

DS2105467

# DEF (adblue®) Quality Sensor

## Repair Procedure Quick Guide

- Step-A. Drain DEF (AdBlue®)
- Step-B. Drain fuel
- Step-C. Remove undercover
- Step-D. Remove battery cover
- Step-E. Remove washer tank
- Step-F. Remove fuel tank bracket
- Step-G. Remove fuel tank
- Step-H. Disconnect wiring harness and quick connector
- Step-I. Remove engine sensors - DEF (AdBlue®) quality sensor

## Removal

1. Turn OFF the battery disconnect switch.

### Draining of DEF (AdBlue®)

1. Suitable container under the DEF (AdBlue®) tank.
2. Loosen drain plug and drain DEF (AdBlue®).
  - DEF (AdBlue®) Tank: 20 L

**NOTE:** *The drain plug is located under the tank.*

**NOTE:** *Be sure to use vinyl gloves.*

**Figure 22**

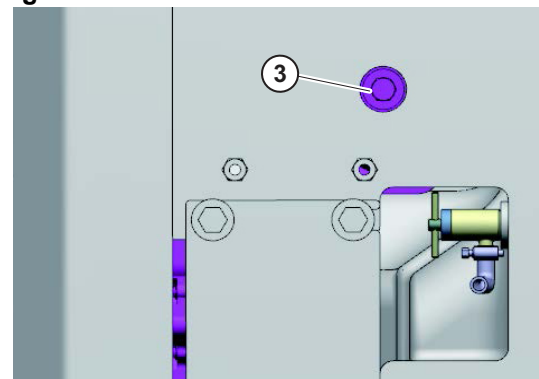

DS2104519

### Draining of Fuel

1. Clean area around fuel tank fill cap. Open fuel cap.
2. Open drain valve at bottom of tank and carefully drain to bowl.
  - Fuel tank capacity: 145 L (38.3 U.S. gal).

**Figure 23**

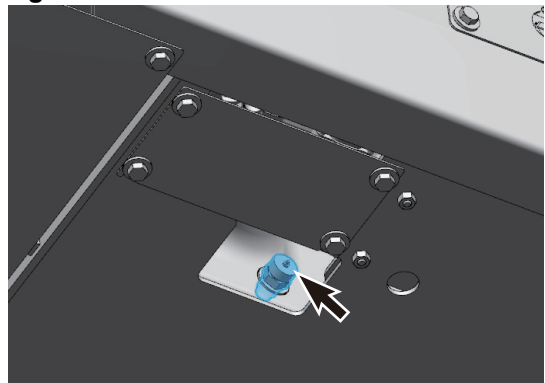

DS2105549

## Undercover

1. Remove the undercover (J).

For details, refer to Undercovers - Removal and Installation.

**Figure 24**

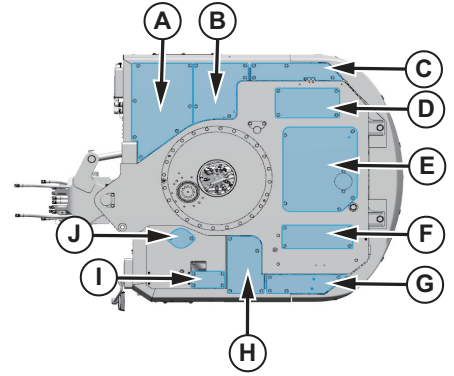

DS2105465

## Battery Cover

1. Remove mounting bolts (1) and battery cover (2) from frame.

- Tool: 19 mm (  )
- Torque: 107.8 N.m (11 kg.m, 79.5 ft lb)

**Figure 25**

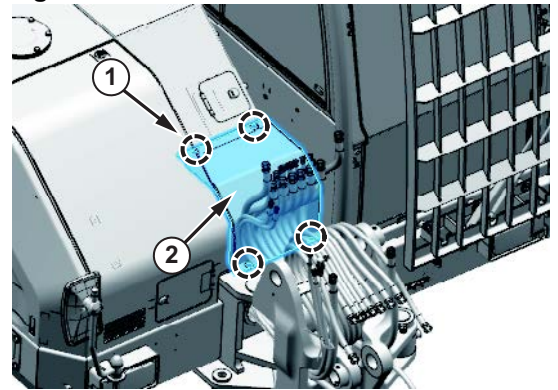

DS2105481

2. Open side door.

**Figure 26**

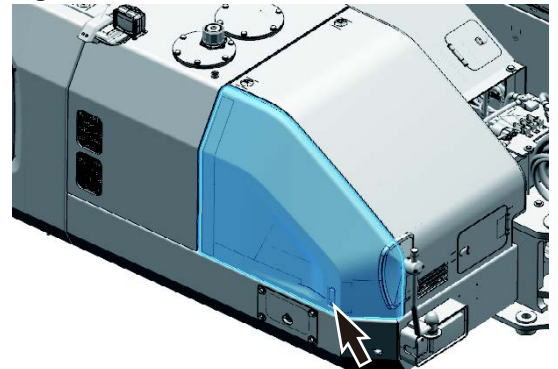

DS2105482

3. Remove mounting bolts (1) and fuel tank cover (2) from frame.

- Tool: 19 mm (  )
- Torque: 107.8 N.m (11 kg.m, 79.5 ft lb)

**Figure 27**

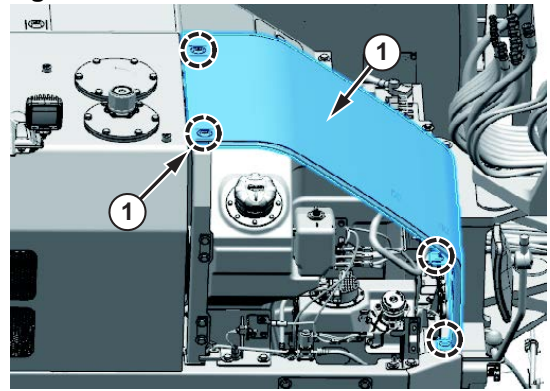

DS2105483

### Washer Tank

1. Disconnect hose and clamp (1) from washer tank.
2. Disconnect wire harness connectors (2) from washer tank.
3. Remove washer tank (3) from fuel tank.

**Figure 28**

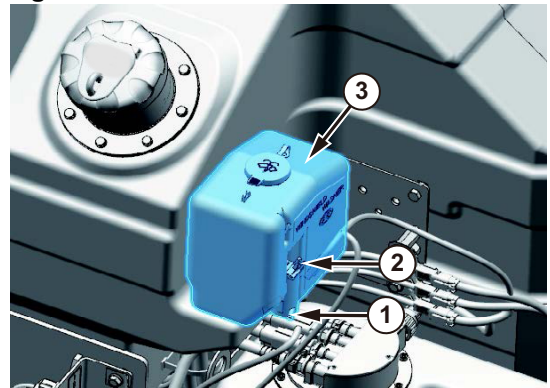

DS2105550

### Fuel Tank Bracket

1. Remove mounting bolts (1) and wire harness plate.

- Tool: 13 mm (  )
- Torque: 29.4 N.m (3 kg.m, 21.7 ft lb)

2. Remove mounting bolts (2) and bracket (3).

- Tool: 19 mm (  )
- Torque: 107.8 N.m (11 kg.m, 79.5 ft lb)

**Figure 29**

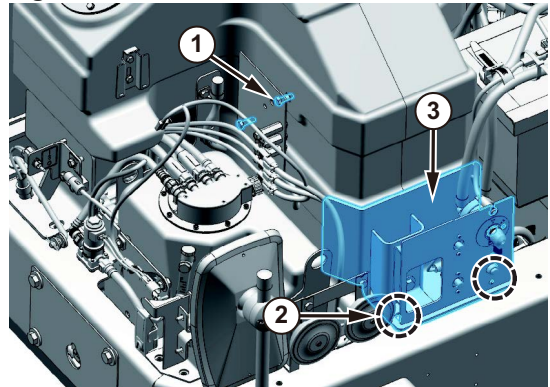

DS2105551

3. Remove mounting bolts (1) and wire harness.

- Tool: 12 mm (  )
- Torque: 29.4 N.m (3 kg.m, 21.7 ft lb)

4. Remove mounting bolts (2) and bracket.

- Tool: 19 mm (  )
- Torque: 107.8 N.m (11 kg.m, 79.5 ft lb)

**Figure 30**

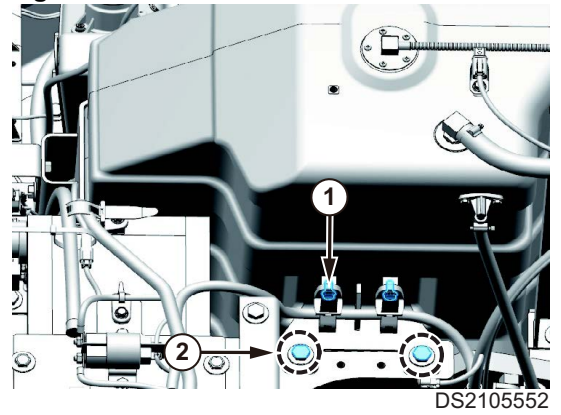

### Fuel Tank

1. Disconnect wire harness connector (1) from fuel tank
2. Disconnect fuel hoses (2, 3) from fuel tank.

**Figure 31**

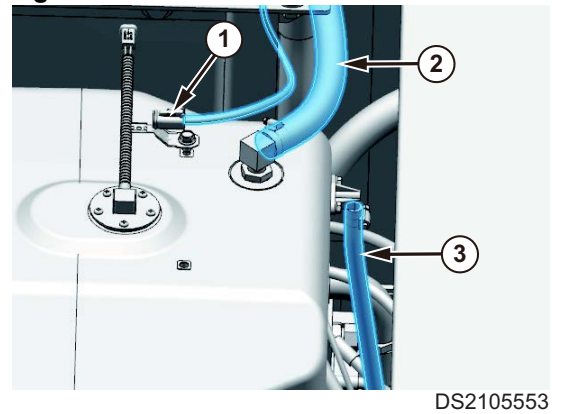

3. Disconnect fuel hose (1) from fuel tank.

**Figure 32**

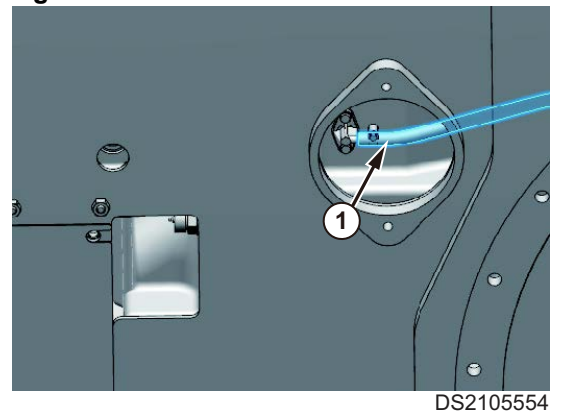



4. Install eyebolts (2 ea) on the fuel tank.  
And tie the rope to the bolts to lift tank (1).
  - Thread of hole: M8 x 1.25
  - Fuel tank weight: 16 kg (35.2 lb)

---

**⚠ NOTICE**

---

Make sure there are no other electrical wires or hoses connected to tank.

---

**NOTE:** *Completely remove tank after inspection*

### DEF (AdBlue®) Quality Sensor

1. Disconnect wire harness connectors (1) from DEF (AdBlue®) quality sensor.
2. Disconnect quick connectors (2).
3. Remove mounting bolts (3).

**NOTE:** *Check the location of the connectors before disconnecting.*

4. Remove DEF (AdBlue®) quality sensor from tank.

**NOTE:** *Quality sensor includes level, concentration, and temperature.*

**NOTE:** *Be sure to use vinyl gloves.*

### Installation

1. Perform installation in the reverse order to removal.

**Figure 33**

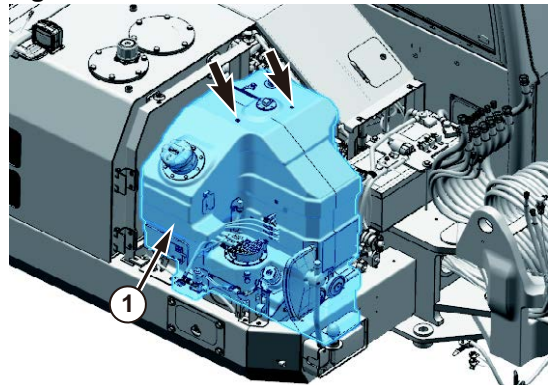

DS2105555

**Figure 34**

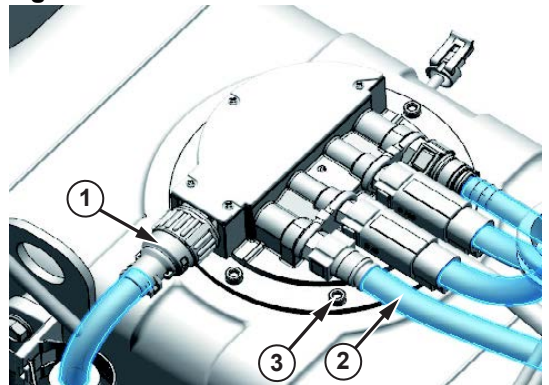

DS2103702

# Sensors - After Treatment

## Repair Procedure Quick Guide

Step-A. Remove engine hood assembly

Step-B. Disconnect wiring harness

Step-C. Removal engine sensors - Temperature Sensor, Upstream NOx sensor, Downstream NOx sensor, DPF pressure sensor

## Removal

### Temperature Sensor

### Upstream NOx Sensor

### Downstream NOx Sensor

### DPF Pressure Sensor

1. Turn OFF the battery disconnect switch.

### Engine Hood Assembly

1. Open engine cover.
2. Open the main pump room cover.

3. Remove mounting bolts (1) and top cover (2).

- Tool: 19 mm ()
- Torque: 107.8 N.m (11 kg.m, 79.5 ft lb)
- Weight: about 25 kg (55.1 lb)

Figure 35



DS2105468

Figure 36

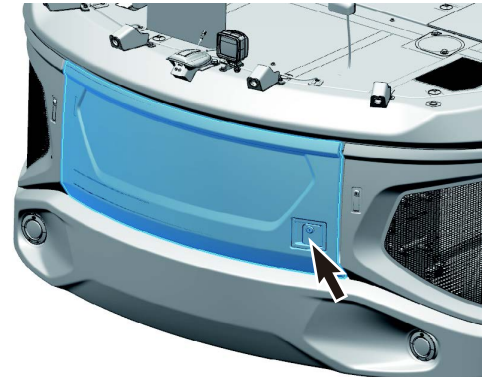
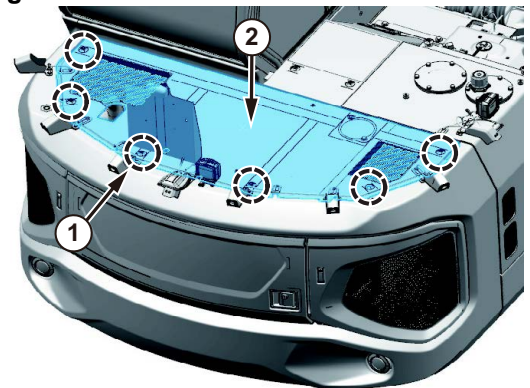

DS2105558

## Engine Sensors - After Treatment System

### Temperature Sensor

1. Disconnect the wiring harness connector from temperature sensor.

- Tool: 17 mm ()
- Torque: 44.1 N.m (4.5 kg.m, 32.5 ft lb)

**NOTE:** Check the location of the connectors before disconnecting.

**NOTE:** Use a brand new cable tie.

2. Remove temperature sensor (1).

**Figure 37**

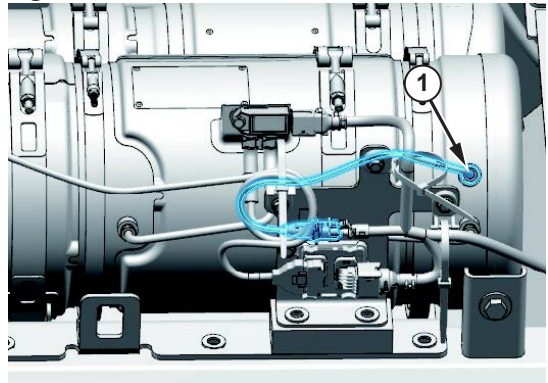

DS2103872

### Upstream NOx Sensor

1. Disconnect wiring harness connector from upstream NOx sensor.

- Tool: 22 mm ()
- Torque: 49 N.m (5 kg.m, 36.1 ft lb)

**NOTE:** Check the location of the connectors before disconnecting.

**NOTE:** Use a brand new cable tie.

2. Remove upstream NOx sensor (1).

**NOTE:** Upstream NOx sensor color is black .

**Figure 38**

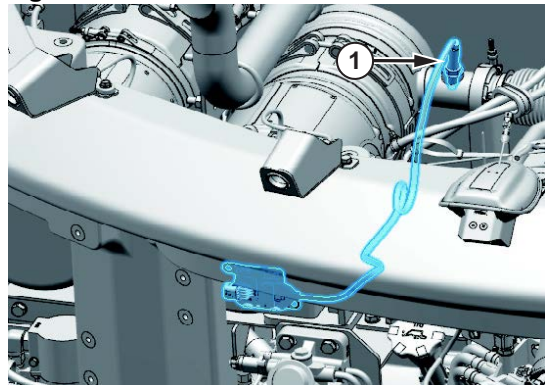

DS2105567

**Figure 39**



DS2103729

## Downstream NOx Sensor

1. Disconnect wiring harness connector from downstream NOx sensor.

- Tool: 22 mm (  )
- Torque: 49 N.m (5 kg.m, 36.1 ft lb)

**NOTE:** Check the location of the connectors before disconnecting.

**NOTE:** Use a brand new cable tie.

2. Remove downstream NOx sensor (1).

**NOTE:** Downstream NOx sensor color is gray.

**Figure 40**

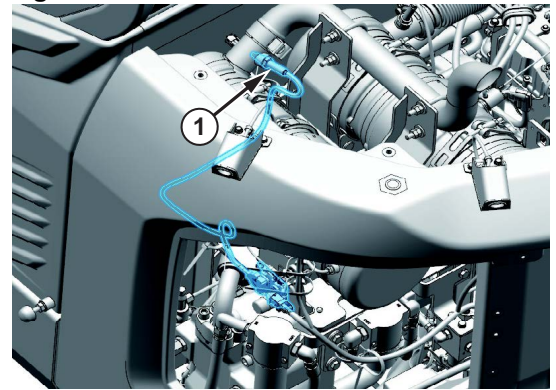

DS2105568

**Figure 41**

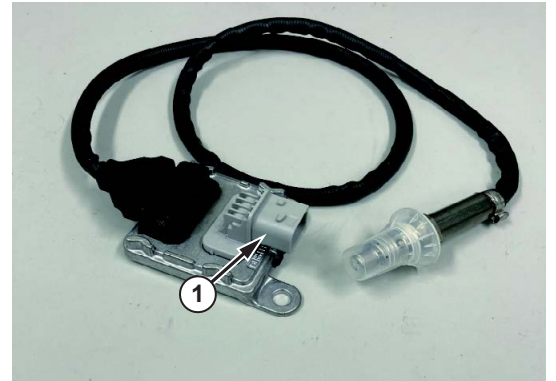

DS2103730

## DPF Pressure Sensor

1. Disconnect wiring harness connector (1) from DPF pressure sensor.

2. Remove pipe and hoses (2).

- Tool: 14 mm (  )

3. Remove bolt (3) and DPF pressure sensor.

- Tool: 10 mm (  )
- Torque: 7.8 N.m (0.8 kg.m, 5.7 ft lb)

**NOTE:** Make sure to position the sensors in the correct connection.

**NOTE:** The DPF sensor must be fitted so that there is no risk of it coming into contact with water, as it is damaged by moisture.

**Figure 42**

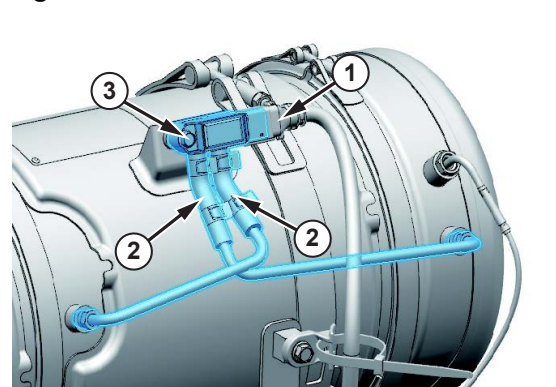

DS2103728

## **Installation**

1. Perform installation in the reverse order to removal.



# Hydraulic Systems and Structure

# Safety Instructions

---

## **WARNING**

---

### AVOID DEATH OR SERIOUS INJURY

Instructions are necessary before operating or servicing machine. Read and understand the Operation & Maintenance Manual and signs (decals) on machine. Follow warnings and instructions in the manuals when making repairs, adjustments or servicing. Check for correct function after adjustments repairs or service. Untrained operators and failure to follow instructions can cause death or serious injury.

---

# Table of Contents

## Hydraulic Systems and Structure

Safety Instructions .....	28
Before Removing and Installing .....	31
Preparatory Work .....	31
General Precaution .....	31
Completing Work .....	31
Undercovers .....	32
Repair Procedure Quick Guide .....	32
Removal .....	32
Installation .....	33
Fuel Tank .....	34
Repair Procedure Quick Guide .....	34
Removal .....	34
Installation .....	37
Drive Coupling.....	38
Repair Procedure Quick Guide .....	38
Removal .....	38
Installation .....	39
Joystick Valve (Work Lever).....	41
Repair Procedure Quick Guide .....	41
Removal .....	41
Installation .....	42
Dozer Joystick Valve .....	43
Repair Procedure Quick Guide .....	43
Removal .....	43
Installation .....	44
brake Supply Valve .....	45
Repair Procedure Quick Guide .....	45
Removal .....	45
Installation .....	46
Brake Pedal Valve .....	47
Repair Procedure Quick Guide .....	47
Removal .....	47
Installation .....	49
Accelerator Pedal Valve .....	50
Repair Procedure Quick Guide .....	50
Removal .....	50
Installation .....	50
Pilot Supply Valve .....	51



Repair Procedure Quick Guide . . . . .	51
Removal . . . . .	51
Installation . . . . .	52
Front Axle . . . . .	53
Repair Procedure Quick Guide . . . . .	53
Removal . . . . .	53
Installation . . . . .	55
Rear Axle . . . . .	56
Repair Procedure Quick Guide . . . . .	56
Removal . . . . .	56
Installation . . . . .	57
Travel Motor . . . . .	59
Repair Procedure Quick Guide . . . . .	59
Removal . . . . .	59
Installation . . . . .	60
Driveshaft . . . . .	61
Repair Procedure Quick Guide . . . . .	61
Removal . . . . .	61
Installation . . . . .	61
Air Condenser Filter . . . . .	62
Repair Procedure Quick Guide . . . . .	62
Removal . . . . .	62
Installation . . . . .	62

# Before Removing and Installing

## Preparatory Work

1. Park the machine on level ground. And lower front attachment to the ground.
2. Set parking brake switch to the parking position and then stop the engine.
3. Support the wheel chock to tire.
4. Move safety lever to "LOCK" position and then stop the engine.
5. Turn battery disconnect switch to "OFF" position.
6. Release the remaining pressure in the hydraulic circuit.
7. Cool down the hydraulic system and engine.
8. Attach a maintenance warning tag on controls.

Figure 43

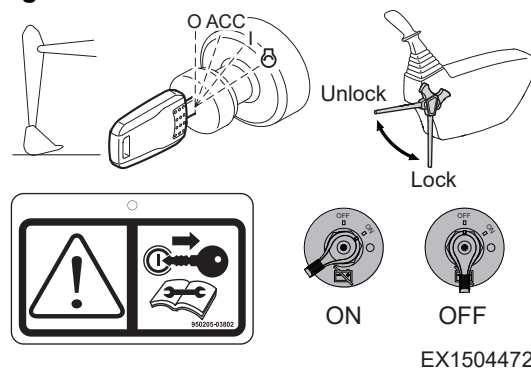

## General Precaution

1. Always read the safety section before removing and installing.
2. Mark the location of the bolts before removing.
3. Keep in the mind the order for tightening bolts.
4. Tighten bolts by hands, then using the tool.
5. If reusing the bolts, clean threads and apply thread locker to threads prior to installation.
6. Mark the location of wire harness connectors and hoses before disconnecting.
7. Be careful not to damage all components.
8. Do not reuse gaskets, O-ring and adhesive bolts.

Figure 44



DS1901903

## Completing Work

1. Check oil, coolant and fuel leak from the machine.
2. Check all oil level and if necessary, add oil.
3. Fill up the fuel tank to the standard level.
4. Apply grease to all lubrication points.
5. When fuel component has been disconnected, air must be bled from circuit.  
For details, see the Operation and Maintenance Manual.
6. When hydraulic component has been disconnected, air must be bled from circuit.  
For details, see the Operation and Maintenance Manual.
7. Start the engine and run at low idle for about 5 minutes.
8. Perform the machine performance test.

# Undercovers

## Repair Procedure Quick Guide

Step-A. Place the machine in the suitable service position

Step-B. Remove undercovers

## Removal

### Undercovers

1. Position the machine on even, firm and level ground.

2. Put attachment on ground.

**NOTE:** Place the machine in the suitable service position

3. Remove undercovers.

- Undercover (A)

- Tool: 19 mm (  )
- Torque: 107.8 N.m (11 kg.m, 79.5 ft lb)
- Weight: about 6.3 kg (13.8 lb)

- Undercover (B)

- Tool: 19 mm (  )
- Torque: 107.8 N.m (11 kg.m, 79.5 ft lb)
- Weight: about 3.5 kg (7.7 lb)

- Undercover (C)

- Tool: 19 mm (  )
- Torque: 107.8 N.m (11 kg.m, 79.5 ft lb)
- Weight: about 1.8 kg (3.9 lb)

- Undercover (D)

- Tool: 19 mm (  )
- Torque: 107.8 N.m (11 kg.m, 79.5 ft lb)
- Weight: about 2.4 kg (5.3 lb)

- Undercover (E)

- Tool: 19 mm (  )
- Torque: 107.8 N.m (11 kg.m, 79.5 ft lb)
- Weight: about 8 kg (11 lb)

- Undercover (F)



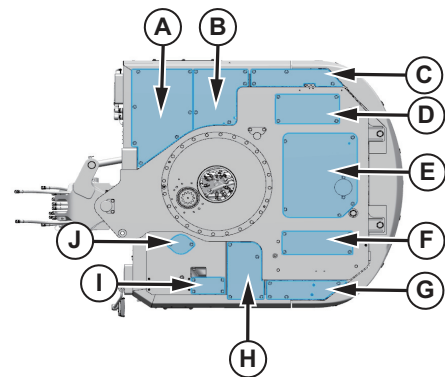

- Tool: 19 mm (  )
- Torque: 107.8 N.m (11 kg.m, 79.5 ft lb)
- Weight: about 2.1 kg (4.6 lb)

- Undercover (G)

Figure 45



DS2105465

- Tool: 19 mm ()
- Torque: 107.8 N.m (11 kg.m, 79.5 ft lb)
- Weight: about 1.6 kg (3.5 lb)
- Undercover (H)
  - Tool: 19 mm ()
  - Torque: 107.8 N.m (11 kg.m, 79.5 ft lb)
  - Weight: about 2.6 kg (5.7 lb)
- Undercover (J)
  - Tool: 19 mm ()
  - Torque: 107.8 N.m (11 kg.m, 79.5 ft lb)
  - Weight: about 0.7 kg (1.5 lb)
- Undercover (I)
  - Tool: 19 mm ()
  - Torque: 107.8 N.m (11 kg.m, 79.5 ft lb)
  - Weight: about 0.3 kg (0.6 lb)

## Installation

1. Perform installation in the reverse order to removal.

# Fuel Tank

## Repair Procedure Quick Guide

Step-A. Drain fuel

Step-B. Remove undercover

Step-C. Remove battery cover

Step-D. Remove washer tank

Step-E. Remove fuel tank bracket

Step-F. Remove fuel tank

## Removal

1. Turn OFF the battery disconnect switch.

### Fuel

1. Clean area around fuel tank fill cap. Open fuel cap.
2. Open drain valve at bottom of tank and carefully drain to bowl.
  - Fuel tank capacity: 145 L (38.3 U.S. gal).

Figure 46

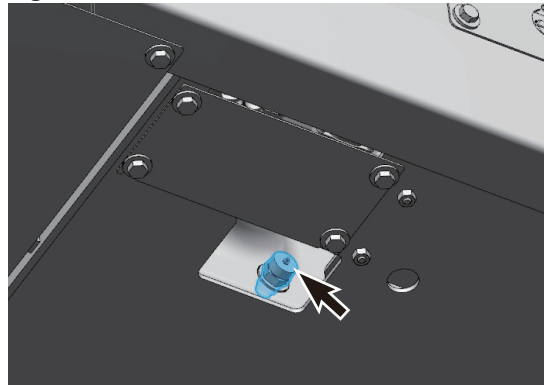

DS2105549

### Undercover

1. Remove the undercover (J).

For details, refer to [Undercovers - Removal and Installation](#).

Figure 47

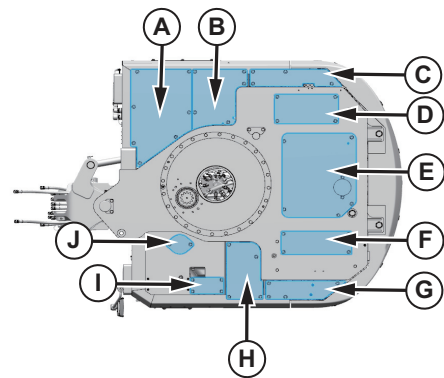

DS2105465

## Battery Cover

1. Remove mounting bolts (1) and battery cover (2) from frame.

- Tool: 19 mm ()
- Torque: 107.8 N.m (11 kg.m, 79.5 ft lb)

**Figure 48**

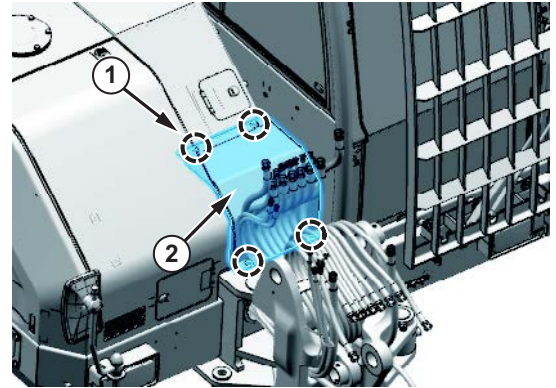

DS2105481

2. Open side door.

**Figure 49**

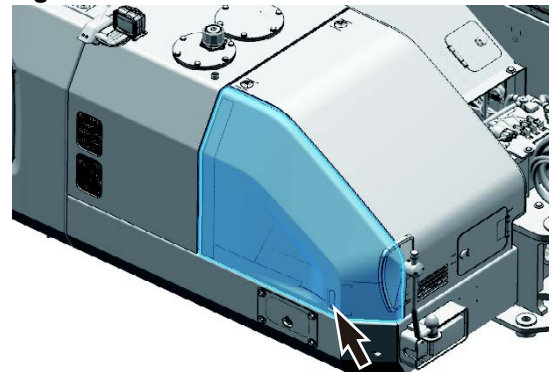

DS2105482

3. Remove mounting bolts (1) and fuel tank cover (2) from frame.

- Tool: 19 mm ()
- Torque: 107.8 N.m (11 kg.m, 79.5 ft lb)

**Figure 50**

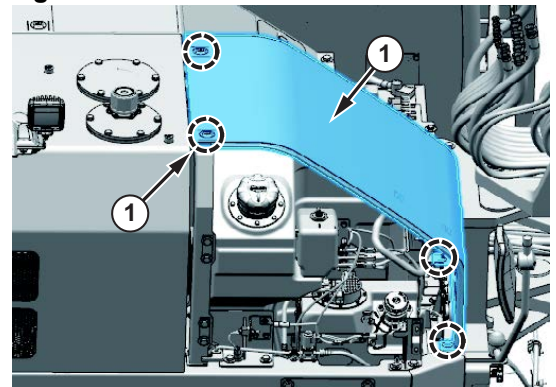

DS2105483

## Washer Tank

1. Disconnect hose and clamp (1) from washer tank.
2. Disconnect wire harness connectors (2) from washer tank.
3. Remove washer tank (3) from fuel tank.

Figure 51

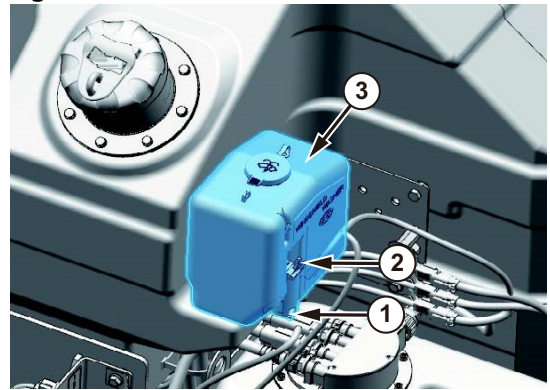

DS2105550

## Fuel Tank Bracket

1. Remove mounting bolts (1) and wire harness plate.

- Tool: 13 mm (  )
- Torque: 29.4 N.m (3 kg.m, 21.7 ft lb)

2. Remove mounting bolts (2) and bracket (3).



- Tool: 19 mm (  )
- Torque: 107.8 N.m (11 kg.m, 79.5 ft lb)

Figure 52

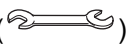
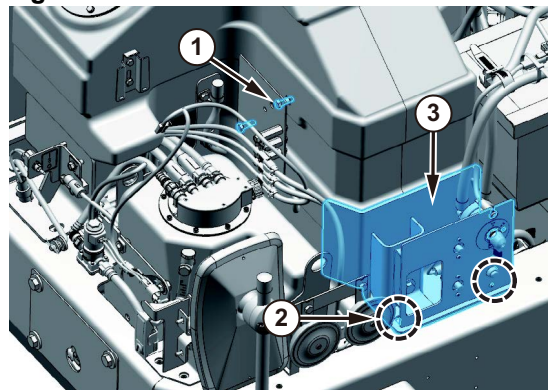

DS2105551

3. Remove mounting bolts (1) and wire harness.

- Tool: 12 mm (  )
- Torque: 29.4 N.m (3 kg.m, 21.7 ft lb)

4. Remove mounting bolts (2) and bracket.

- Tool: 19 mm (  )
- Torque: 107.8 N.m (11 kg.m, 79.5 ft lb)

Figure 53



DS2105552

## Fuel Tank

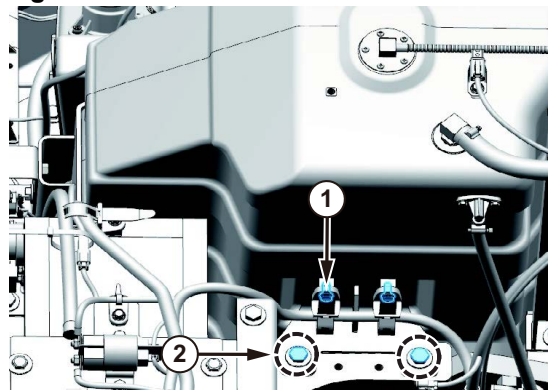
1. Disconnect wire harness connector (1) from fuel tank
2. Disconnect fuel hoses (2, 3) from fuel tank.

Figure 54

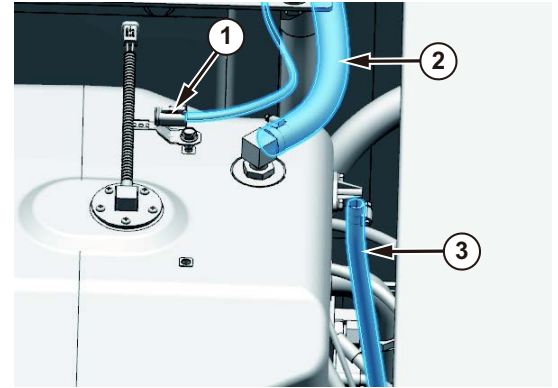

DS2105553

3. Disconnect fuel hose (1) from fuel tank.

Figure 55

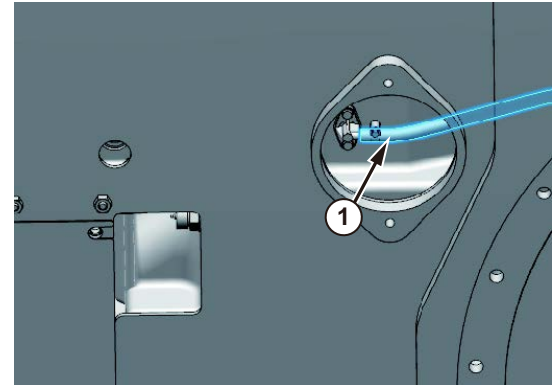

DS2105554

4. Install eyebolts (2 ea) on the fuel tank.  
And tie the rope to the bolts to lift tank (1).
  - Thread of hole: M8 x 1.25
  - Fuel tank weight: 16 kg (35.2 lb)

---

### NOTICE

---

Make sure there are no other electrical wires or hoses connected to tank.

---

**NOTE:** *Completely remove tank after inspection*

Figure 56

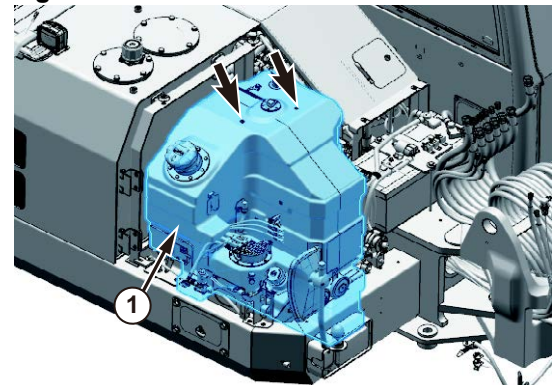

DS2105555

## Installation

1. Perform installation in the reverse order to removal.



# Drive Coupling

## Repair Procedure Quick Guide

Step-A. Remove main pump assembly

Step-B. Remove drive coupling

## Removal

### Main Pump Assembly

1. Remove the main pump assembly.

For details, refer to [Main pump - Removal and Installation](#).

When the pump is removed from an engine, the hub and insert would be attached on the pump.

Figure 57

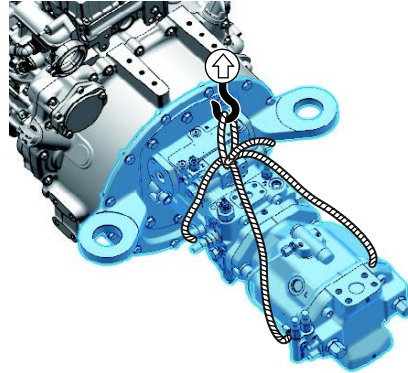

DS2105566

### Drive Coupling Assembly

#### Main Pump Side

1. Remove bolts (1) and inserts (2) from the hub (4).

- Torque: 215.7 N.m (22 kg.m, 159.1 ft lb)

2. Remove clamp screws (3) and hub (4) from the main pump shaft.

- Torque: 107.8 N.m (11 kg.m, 79.5 ft lb)

Figure 58

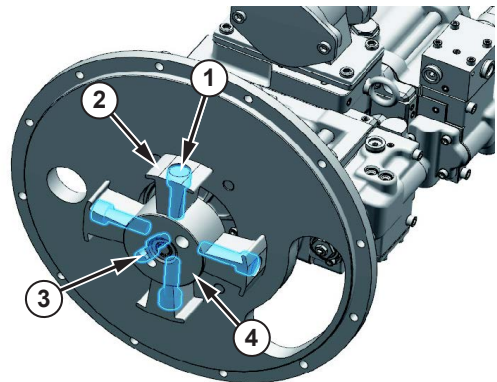

DS2103876

## Engine Side

1. Remove element (1) and bolts (2) with inserts (3) and spring pins from flywheel.

- Tool: 14 mm 
- Torque: 215.7 N.m (22 kg.m, 159.1 ft lb)

**Figure 59**

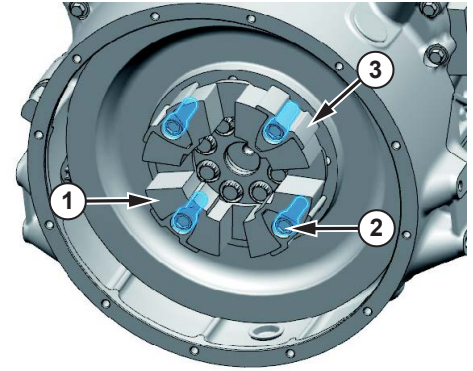

DS2103877

## **Installation**

### **Drive Coupling**

#### Engine Side

1. Install bolts (2) and inserts (3) with element (1) to flywheel.

- Tool: 14 mm 
- Torque: 215.7 N.m (22 kg.m, 159.1 ft lb)

**Figure 60**

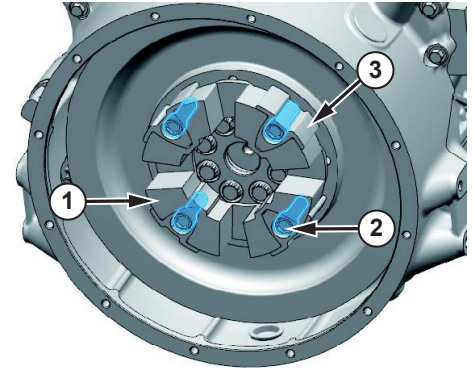

DS2103877

#### Main Pump Side

1. Check the “E” mark on the hub, it is must install toward engine side.
2. Clearance between from pump shaft to coupling hub must be 13 mm.

**Figure 61**

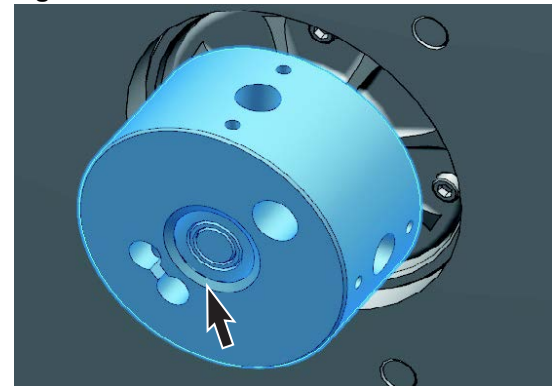

DS2103878

3. Install clamp screws (3) and hub (4) to the main pump shaft.

- Torque: 107.8 N.m (11 kg.m, 79.5 ft lb)

**NOTE:** Apply adhesive (Loctite #262) to the mounting bolt.

4. Install bolts (1) and inserts (2) to the hub (4).

- Torque: 215.7 N.m (22 kg.m, 159.1 ft lb)

**Figure 62**

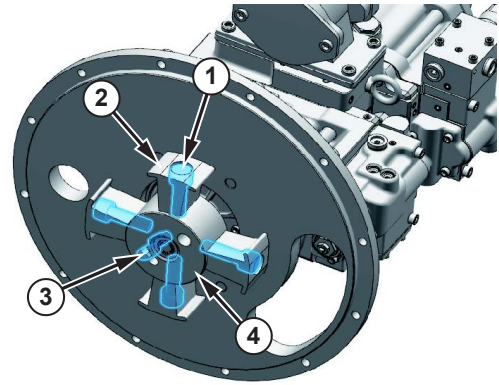

DS2103876

### Main Pump Assembly

1. Install the main pump assembly.

For details, refer to [Main Pump - Removal and Installation](#).

---

**⚠ NOTICE**

---

Element is not resistant to bonding compounds, oil or grease.  
Be careful not to expose them to it.

---

Remove oil or dirt from flywheel cover and pump shaft before assembly.

**Figure 63**

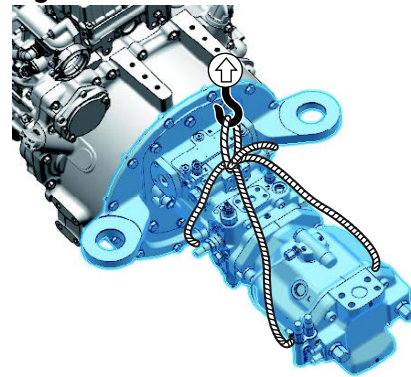

DS2105566

# Joystick Valve (Work Lever)

## Repair Procedure Quick Guide

Step-A. Open the cabin door

Step-B. Remove stand upper cover - left side, right side

Step-C. Disconnect hydraulic hoses

Step-D. Remove joystick valve (work lever)

## Removal

1. Turn OFF the battery disconnect switch.

2. Open the cabin door.

### Stand Upper Cover - Left Side

1. Remove dozer blade control lever knob (1).

2. Remove mounting bolt and grip (2).

3. Remove cap and mounting screws (3) from stand upper cover.

4. Remove stand upper cover (4).

5. Remove screws and stand cover.

Figure 64

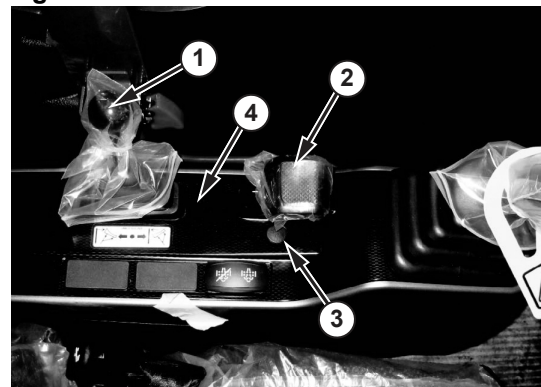

DS2001559

### Stand Upper Cover - Right Side

1. Remove cap and mounting screws (1) from stand upper cover.

2. Remove stand upper cover (2).

3. Remove screws and stand cover.

Figure 65



DS2001557

## Hydraulic Hoses

1. Disconnect hydraulic hoses (1) and from joystick valve (2).

**NOTE:** Attach identification tags to the removed hoses for reassembling.

**NOTE:** After disconnecting hoses from joystick valve, plug them to prevent dirt or dust from entering.

Figure 66

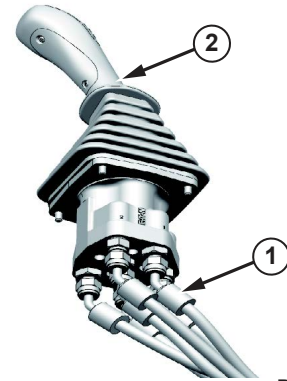

DS2001589

## Joystick Valve (Work Lever)

1. Remove mounting bolts (1) from joystick valve.

- Tool: 5 mm (  )

2. Remove joystick valve (2) from stand.

## Installation

1. Perform installation in the reverse order to removal.

Figure 67



DS2001588

# Dozer Joystick Valve

## Repair Procedure Quick Guide

Step-A. Open the cabin door

Step-B. Remove stand upper cover - left side

Step-C. Disconnect hydraulic hoses

Step-D. Remove dozer joystick valve

## Removal

1. Turn OFF the battery disconnect switch.

2. Open the cabin door.

### Stand Upper Cover - Left Side

1. Remove dozer blade control lever knob (1).

2. Remove mounting bolt and grip (2).

3. Remove cap and mounting screws (3) from stand upper cover.

4. Remove stand upper cover (4).

Figure 68

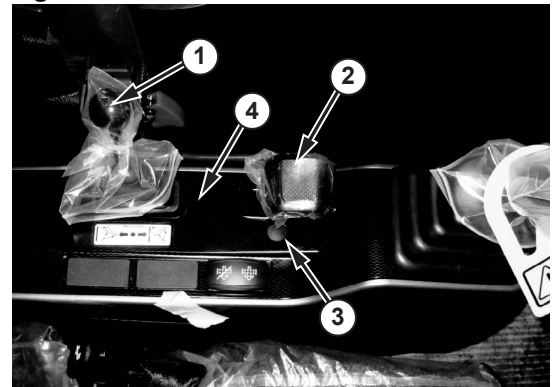

DS2001559

### Hydraulic Hoses

1. Disconnect hydraulic hoses and from dozer joystick valve.

**NOTE:** Attach identification tags to the removed hoses for reassembling.

**NOTE:** After disconnecting hoses from dozer valve, plug them to prevent dirt or dust from entering.

Figure 69

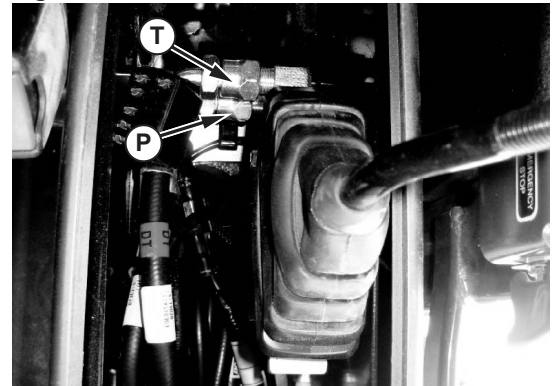

DS2001564

## Dozer Joystick Valve

1. Remove mounting bolts (1) from dozer joystick valve (2).

- Tool: 10 mm (  )

2. Remove dozer joystick valve (2) from cabin stand.

## Installation

---

### **WARNING**

---

INCORRECT INSTALLATION CAN CAUSE DEATH OR SERIOUS INJURY

Any change in the connections will lead to malfunctions (e.g. lift instead of lower).

- When connecting hydraulic components, observe the specified piping according to the hydraulic schematic diagram of the machine.

---

1. Perform installation in the reverse order to remove.

2. Keep the assembly angle when installing the hoses to dozer valve.

**Figure 70**

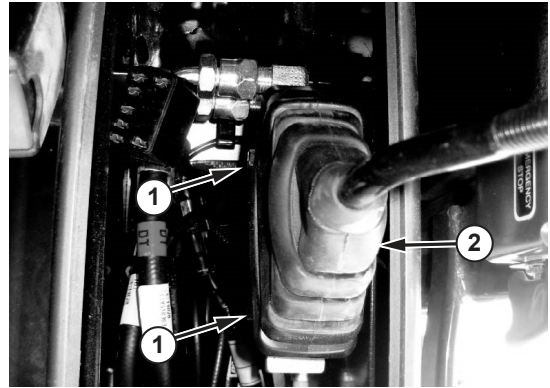

DS2001563

# brake Supply Valve

## Repair Procedure Quick Guide

- Step-A. Open the engine cover
- Step-B. Remove undercovers
- Step-C. Disconnect wire harness
- Step-D. Disconnect hydraulic hoses
- Step-E. Remove brake supply valve

## Removal

- 1. Turn OFF the battery disconnect switch.

### Undercover

- 1. Remove the undercover (A, B).

For details, refer to [Undercovers - Removal and Installation.](#)

Figure 71

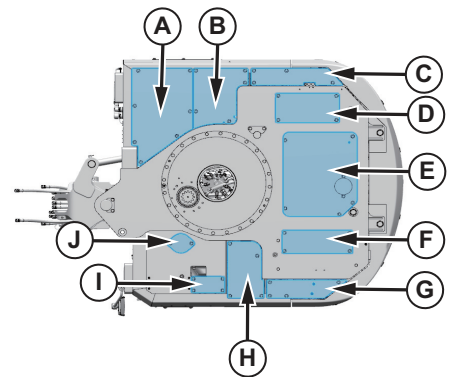

DS2105465

### Wiring Harness

- 1. Disconnect wiring harness connectors (1) from the brake supply valve.

Figure 72

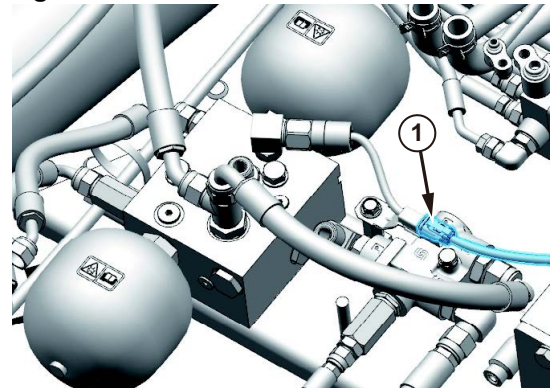

DS2105546



## Hydraulic Hose

1. Disconnect hydraulic hoses (1) and from brake supply valve.

**NOTE:** Attach identification tags to the removed hoses for reassembling.

**NOTE:** After disconnecting hoses from brake supply valve, plug them to prevent dirt or dust from entering.

**Figure 73**

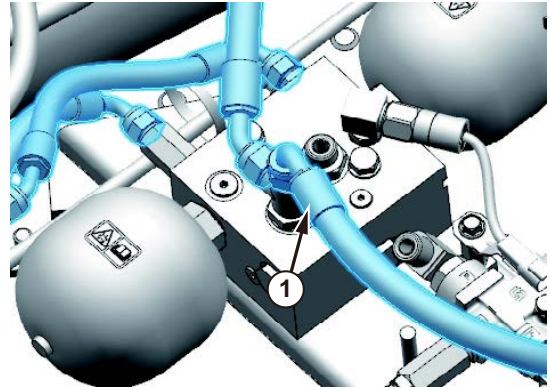

DS2105547

## Brake Supply Valve

1. Remove bolts (1) and brake supply valve (2) from main frame.

- Tool: 17 mm (  )
- Torque: 63.7 N.m (6.5 kg.m, 47 ft lb)
- Brake supply valve: 10 kg (22 lb)

**Figure 74**

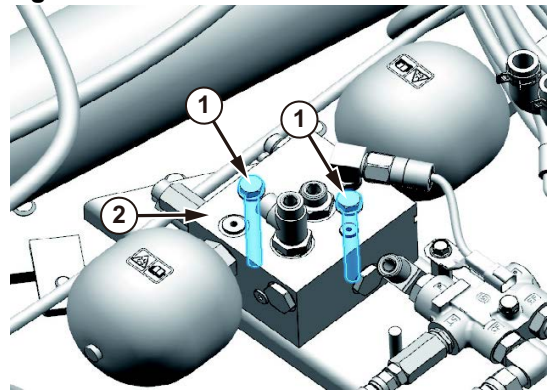

DS2105548

## Installation

1. Perform installation in the reverse order to removal.
2. When installing the hose, be install the drain hose first.

# Brake Pedal Valve

## Repair Procedure Quick Guide

Step-A. Open the cabin door

Step-B. Open the front window

Step-C. Remove cabin floor cover

Step-D. Remove under cover

Step-E. Disconnect wiring harness

Step-F. Disconnect hydraulic hoses

Step-G. Remove brake pedal valve

## Removal

1. Turn OFF the battery disconnect switch.
2. Open the cabin door.

### Front Window

1. Stow the front upper window (1) in the cabin ceiling.
2. Open the lower window (2) from cabin in direction of the arrow.

Figure 75

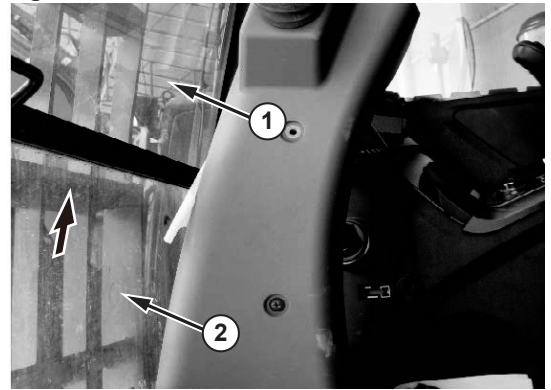

DS2001615

### Cabin Floor Cover

1. Remove front floor mat (1) from the cabin.
2. Remove rear floor mat (2) from the cabin.

Figure 76

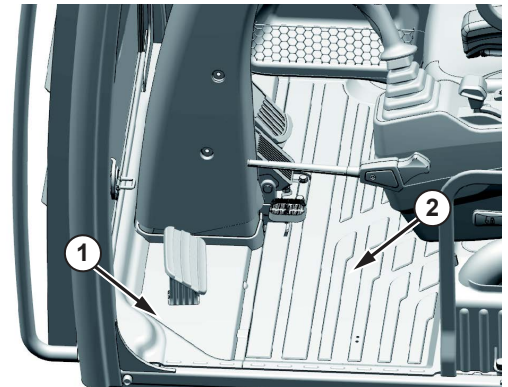

DS2001616

3. Remove bolts (1) with cover (2).

- Tool: 13 mm (  )
- Torque: 19.6 N.m (2 kg.m, 14.5 ft lb)
- Cover weight: 9 kg (19.8 lb)

**Figure 77**

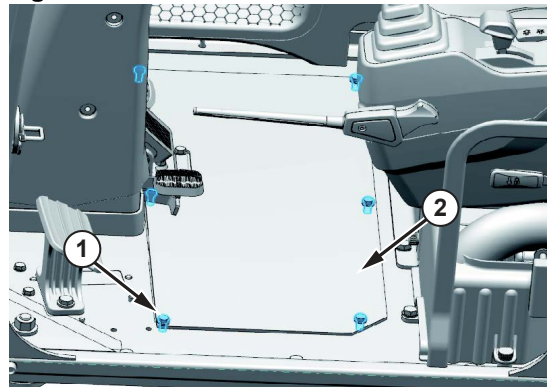

DS2001617

### Undercover

1. Remove the undercover (A).

For details, refer to [Undercovers - Removal and Installation](#).

**Figure 78**

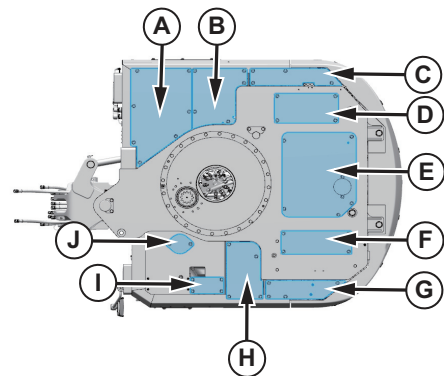

DS2105465

### Wiring Harness

1. Disconnect the harness connector from brake pedal valve.

**Figure 79**

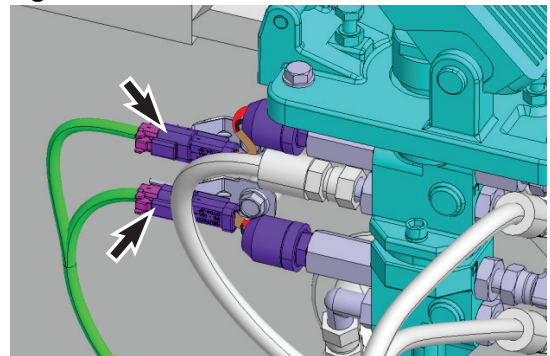

WE1501403

## Hydraulic Oil

1. Loosen the oil tank air breather slowly to release the pressure inside the hydraulic oil tank. Pulling the air breather cap upward, the check valve opens, and the air is discharged to the atmosphere from the top of the hydraulic oil tank.

Figure 80



DS2105563

## Hydraulic Hoses

1. Remove hydraulic hoses (1) from brake pedal valve.

**NOTE:** Attach an identification tags to the removed hoses for reassembling. After disconnecting hoses, plug them to prevent dirt or dust from entering. Disconnect the hoses from the bottom to top of brake pedal valve.

Figure 81

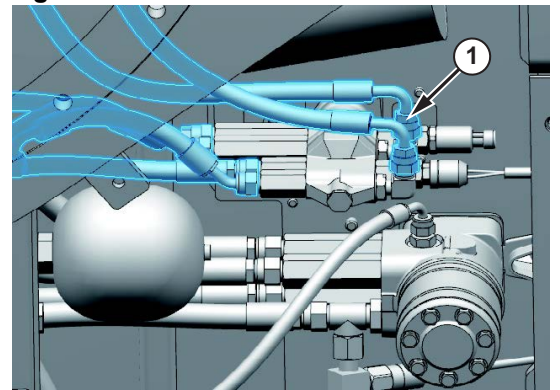

DS2105569

## Brake Pedal Valve

1. Remove bolts (1) and brake pedal valve (2) from floor plate.

- Tool: 13 mm (🔧)
- Torque: 19.6 N.m (2 kg.m, 14.5 ft lb)
- Cover weight: 4.1 kg (11 lb)

Figure 82

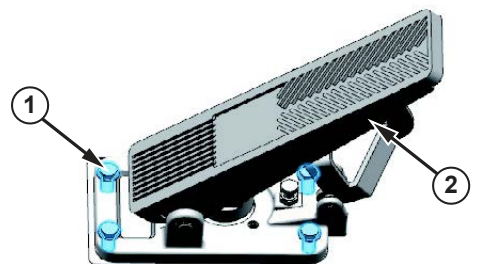

DS2001618

## Installation

1. Perform installation in the reverse order to removal.
2. When installing the hose, be install the drain hose first.

# Accelerator Pedal Valve

## Repair Procedure Quick Guide

Step-A. Open the cabin door

Step-B. Disconnect wiring harness

Step-C. Remove accelerator pedal

## Removal

1. Turn OFF the battery disconnect switch.
2. Open the cabin door.

## Wiring Harness

1. Disconnect the harness connector (1) from accelerator pedal (2).

Figure 83

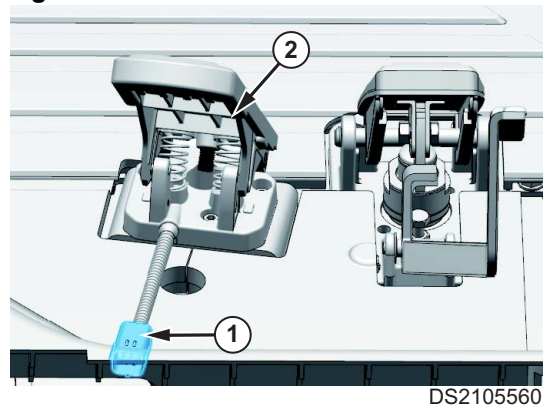

## Accelerator Pedal

1. Remove mounting bolts (1) and accelerator pedal (2) from floor plate.

- Tool: 5 mm (  )

Figure 84



## Installation

1. Perform installation in the reverse order to removal.
2. When installing the hose, be install the drain hose first.

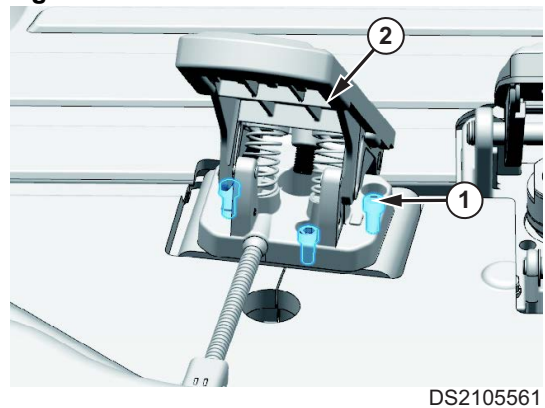
# Pilot Supply Valve

## Repair Procedure Quick Guide

Step-A. Open the engine cover

Step-B. Remove undercovers

Step-C. Remove frame cover

Step-D. Disconnect wire harness

Step-E. Disconnect hydraulic hoses

Step-F. Remove pilot supply valve

## Removal

1. Turn OFF the battery disconnect switch.

### Undercover

1. Remove the undercover (A, B).

For details, refer to [Undercovers - Removal and Installation](#).

Figure 85

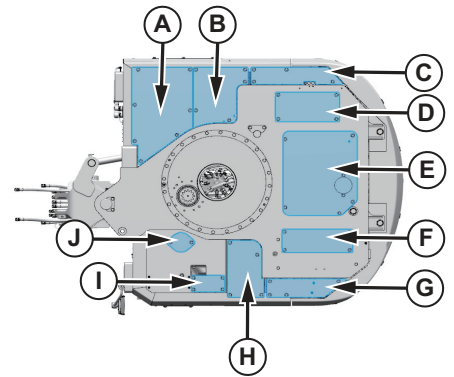

DS2105465

### Frame Cover

1. Remove mounting bolts (1) and frame cover (2).

- Tool: 19 mm ()
- Torque: 107.8 N.m (11 kg.m, 79.5 ft lb)

Figure 86



DS2105489

## Wiring Harness

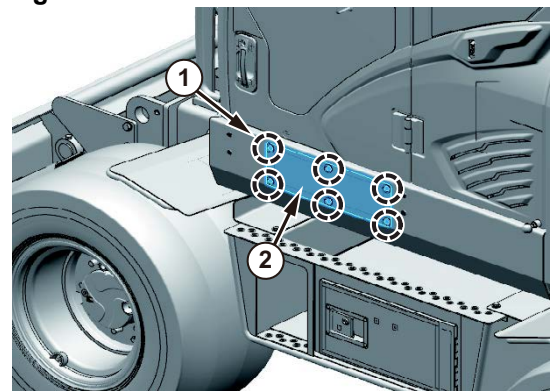
1. Disconnect wiring harness connectors (1) from the pilot supply valve.

Figure 87

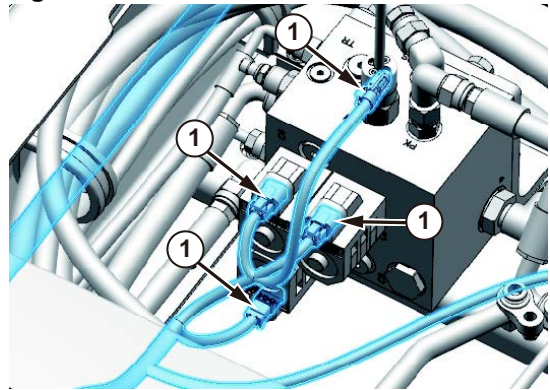

DS2105490

## Hydraulic Hose

1. Disconnect hydraulic hoses (1) and from pilot supply valve.

**NOTE:** Attach identification tags to the removed hoses for reassembling.

**NOTE:** After disconnecting hoses from pilot supply valve, plug them to prevent dirt or dust from entering.

Figure 88

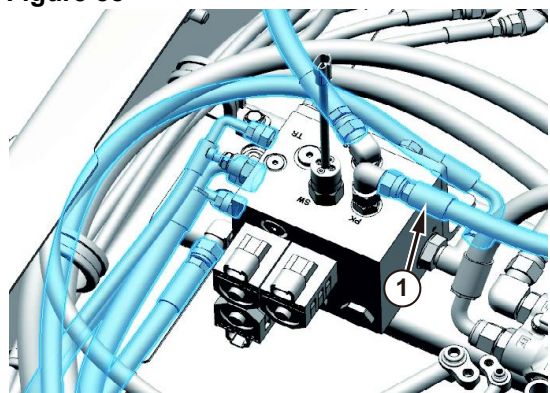

DS2105544

## Pilot Supply Valve

1. Remove bolts (1) and pilot supply valve (2) from main frame.

- Tool: 17 mm (  )
- Torque: 63.7 N.m (6.5 kg.m, 47 ft lb)
- Pilot supply valve: 5.6 kg (12.3 lb)

Figure 89



DS2105545

## Installation

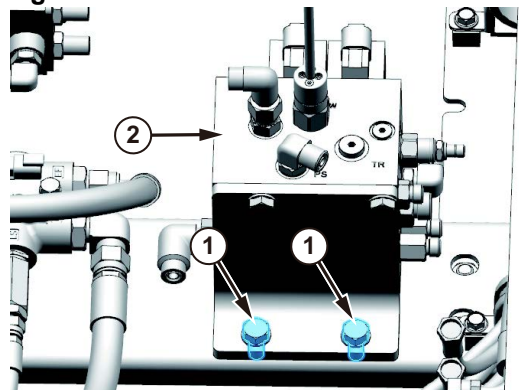
1. Perform installation in the reverse order to removal.
2. When installing the hose, be install the drain hose first.

# Front Axle

## Repair Procedure Quick Guide

- Step-A. Remove front tire
- Step-B. Remove drive shaft
- Step-C. Remove cover
- Step-D. Disconnect hydraulic hoses
- Step-E. Remove front axle

## Removal

1. Turn OFF the battery disconnect switch.

### Hydraulic Oil

1. Loosen the oil tank air breather slowly to release the pressure inside the hydraulic oil tank. Pulling the air breather cap upward, the check valve opens, and the air is discharged to the atmosphere from the top of the hydraulic oil tank.

Figure 90



DS2105563

### Front Tire



1. Support the wheel chock to rear tire.
2. Lift the front of the vehicle using the outrigger to place a chock under the front frame.
3. Tie the front tire with rope to remove it.
4. Remove wheel nuts (1)
  - Tool: 32 mm (  )
  - Torque: 539.3 N.m (55 kg.m, 397.8 ft lb)
5. Remove wheel bolts (2) then hoist and remove tire from the axle.

Figure 91

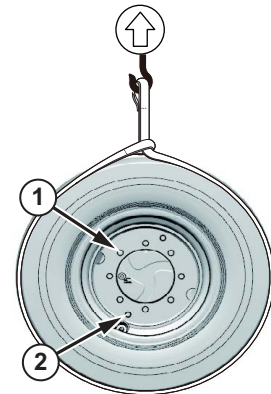

DS2105571

- Tool: 19 mm (  )
- Torque: 107.8 N.m (11 kg.m, 79.5 ft lb)



## Drive Shaft

1. Remove mounting bolts (1).

- Tool: 14 mm (  )
- Torque: 68.6 N.m (7 kg.m, 50.6 ft lb)

**NOTE:** Apply adhesive (Loctite #262) to the mounting bolt.

2. Remove drive shaft (2) from axle and transmission.

Figure 92

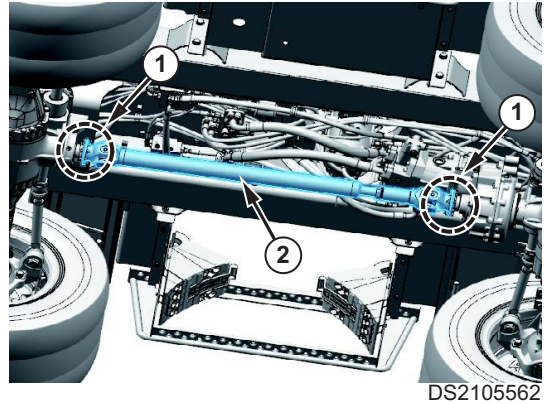

DS2105562

## Cover

1. Remove mounting bolts (1) from chassis frame.

- Tool: 17 mm (  )
- Torque: 63.7 N.m (6.5 kg.m, 47 ft lb)
- Weight: about 10 kg (22 lb)

2. Remove cover (2) from chassis frame.

Figure 93

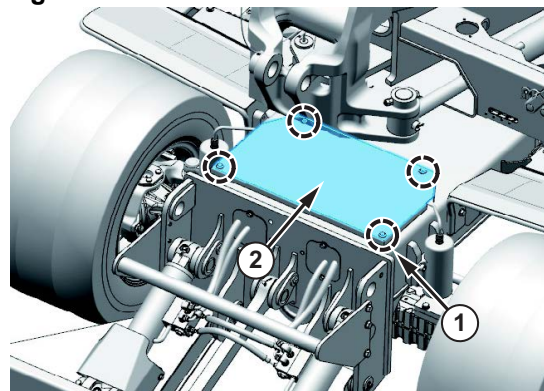

DS2105570

## Hydraulic Hoses

1. Remove hose and pipes (1, 2) from the front axle.

**NOTE:** After disconnecting hose, plug it to prevent dirt or dust from entering to hose and axle hole.

Figure 94

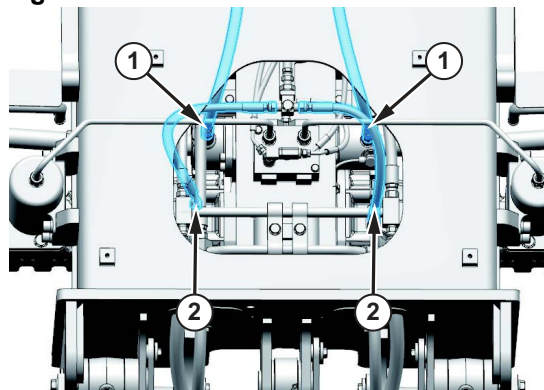

DS2105573

## Front Axle

1. Support jack and lift under the axle.
  - Weight of axle: about 413 kg (910.5 lb)
2. Remove mounting bolt (1) from front axle.
3. Remove front axle (2) from frame.

- Tool: 30 mm 
- Torque: 264.7 N.m (55 kg.m, 195.2 ft lb)

**NOTE:** Apply adhesive (Loctite #262) to the mounting bolt.

4. Remove front axle slowly and carefully.

Figure 95

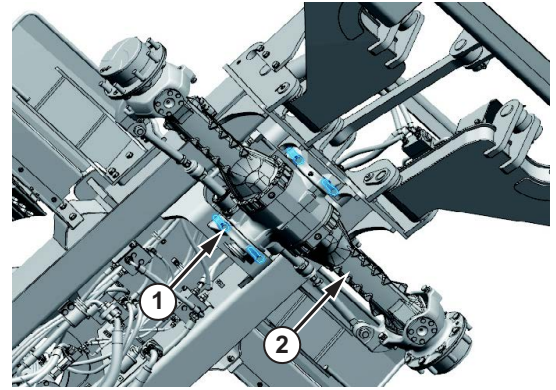

DS2105572

## Installation

1. Perform installation in the reverse order to removal.

**NOTE:** After installing the axle to the frame, check that it oscillates freely.

2. Release the chocking cylinder line for the correct installing of the front axle fixing pin.

- Axle oil specification and quantity
  - Replace oil: genuine oil
  - Oil specification: SAE 80W90
  - Differential oil quantity: 7.5 L (2.0 U.S. gal)
  - Hub oil quantity: 2 x 0.8 L (2 x 0.2 U.S. gal)

3. Start engine.
4. Loosen the brake bleeding plug.
5. Push brake pedal slowly.
6. Keep pouring until the oil appears clean without gas bubbles at brake bleeding plug.
7. Tighten the brake bleeding plug.

Figure 96

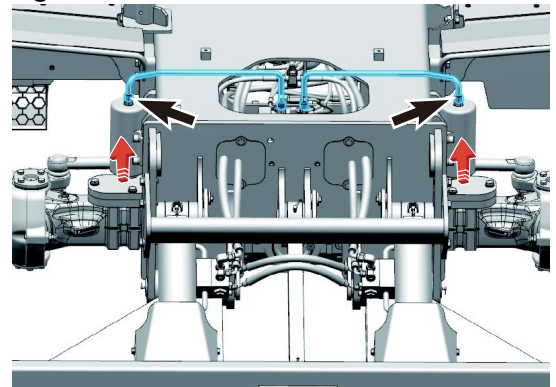

DS2105667

# Rear Axle

## Repair Procedure Quick Guide

Step-A. Remove rear tire

Step-B. Remove drive shaft

Step-C. Disconnect hydraulic hoses

Step-D. Remove rear axle

## Removal

1. Turn OFF the battery disconnect switch.

### Hydraulic Oil

1. Loosen the oil tank air breather slowly to release the pressure inside the hydraulic oil tank. Pulling the air breather cap upward, the check valve opens, and the air is discharged to the atmosphere from the top of the hydraulic oil tank.

Figure 97

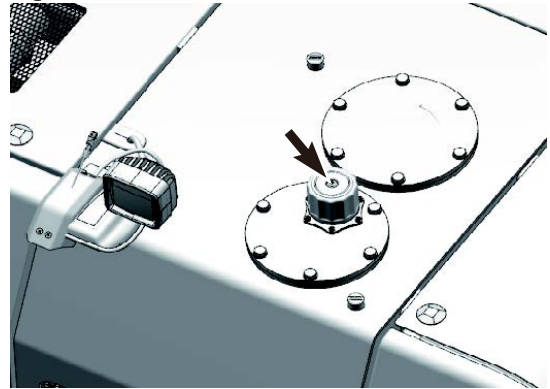

DS2105563

### Rear Tire

1. Support the wheel chock to front tire.
2. Lift the rear of the vehicle using the dozer.
3. Tie the rear tire with rope to remove it.
4. Remove wheel nuts (1).

- Tool: 32 mm ()
- Torque: 539.3 N.m (55 kg.m, 397.8 ft lb)

5. Remove wheel bolts (2) then hoist and remove tire from the axle.

- Tool: 19 mm ()
- Torque: 107.8 N.m (11 kg.m, 79.5 ft lb)

Figure 98



DS2105571

## Drive Shaft

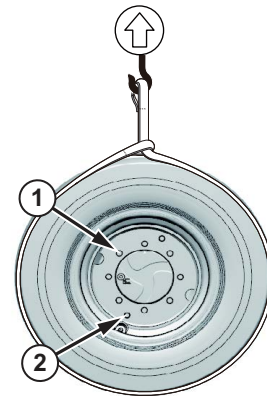
1. Remove mounting bolts (1).

- Tool: 14 mm (  )
- Torque: 68.6 N.m (7 kg.m, 50.6 ft lb)

**NOTE:** Apply adhesive (Loctite #262) to the mounting bolt.

2. Remove drive shaft (2) from axle and transmission.

Figure 99

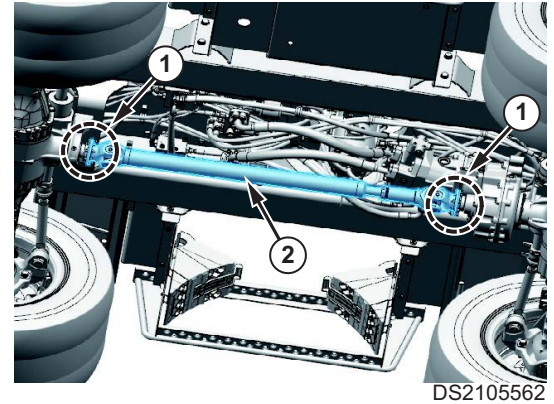

## Hydraulic Hoses

1. Disconnect wire harness connectors (1).

2. Remove hose and pipes (2) from the rear axle.

**NOTE:** After disconnecting hose, plug it to prevent dirt or dust from entering to hose and axle hole.

Figure 100

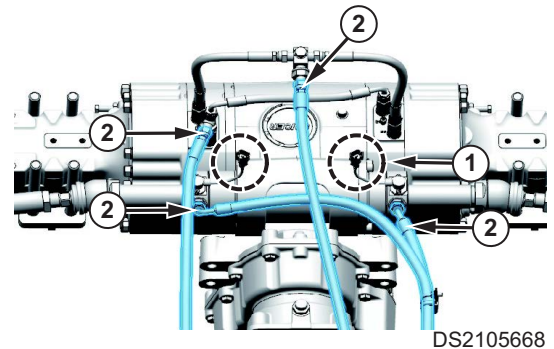

## Rear Axle

1. Support jack and lift under the axle.

- Weight of axle: about 520 kg (1146.4 lb)

2. Remove mounting bolts (1) from rear axle (2).

- Tool: 29 mm (  )
- Torque: 539.3 N.m (55 kg.m, 397.8 ft lb)

**NOTE:** Apply adhesive (Loctite #262) to the mounting bolt.

3. Remove rear axle slowly and carefully.

Figure 101

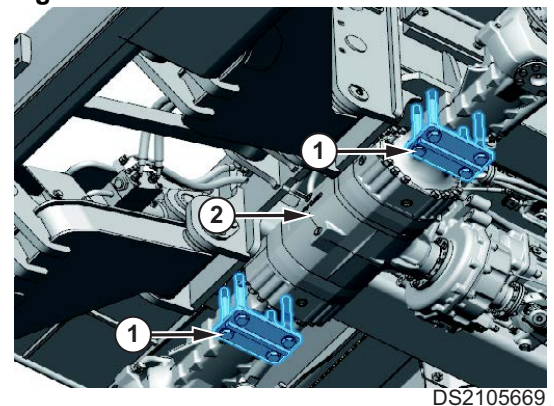

## Installation

1. Perform installation in the reverse order to removal.

- Axle oil specification and quantity
  - Replace oil: genuine oil
  - Oil specification: SAE 80W90
  - Differential oil quantity: 8.1 L (2.1 U.S. gal), 2Wheel Steer
  - Differential oil quantity: 6.8 L (1.8 U.S. gal), 4Wheel Steer

- Hub oil quantity: 2 x 0.8 L (2 x 0.2 U.S. gal)
2. Start engine.
  3. Loosen the brake bleeding plug.
  4. Push brake pedal slowly.
  5. Keep pouring until the oil appears clean without gas bubbles at brake bleeding plug.
  6. Tighten the brake bleeding plug.

# Travel Motor

## Repair Procedure Quick Guide

Step-A. Remove drive shaft

Step-B. Disconnect hydraulic hoses

Step-C. Remove travel motor

## Removal

1. Turn OFF the battery disconnect switch.

### Hydraulic Oil

1. Loosen the oil tank air breather slowly to release the pressure inside the hydraulic oil tank. Pulling the air breather cap upward, the check valve opens, and the air is discharged to the atmosphere from the top of the hydraulic oil tank.

Figure 102

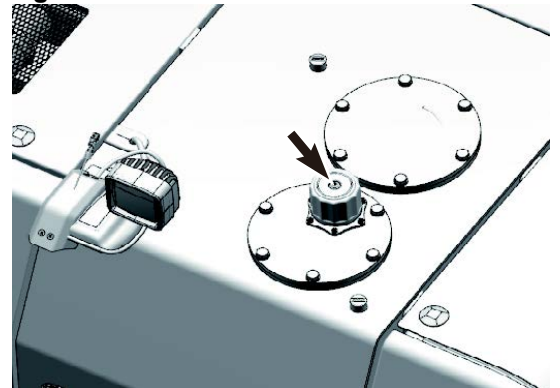

DS2105563

### Drive Shaft

1. Remove mounting bolts (1).

- Tool: 14 mm 
- Torque: 68.6 N.m (7 kg.m, 50.6 ft lb)

**NOTE:** Apply adhesive (Loctite #262) to the mounting bolt.

2. Remove drive shaft (2) from axle and transmission.

Figure 103

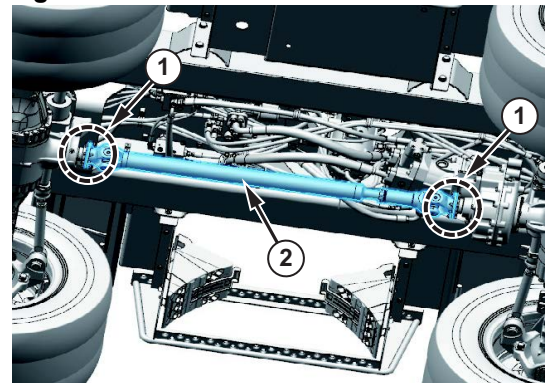

DS2105562

## Hydraulic Hoses

1. Disconnect hydraulic hoses (1) and from travel motor.

**NOTE:** Attach identification tags to the removed hoses for reassembling.

**NOTE:** After disconnecting hoses from travel motor, plug them to prevent dirt or dust from entering.

Figure 104

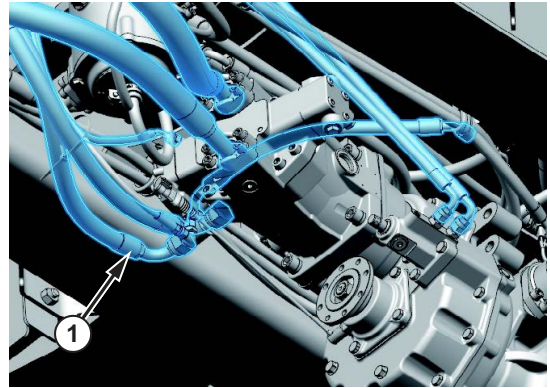

DS2105564

## Travel Motor

1. Place wood block under the travel motor (2).

**NOTE:** When support it, be careful do not to damage the relief valve on travel motor.

2. Remove mounting bolts (1).

- Tool: 14 mm (  )
- Torque: 264.7 N.m (27 kg.m, 195.2 ft lb)

**NOTE:** Apply adhesive (Loctite #262) to the mounting bolt.

3. Remove travel motor (2) slowly and carefully.

- Travel motor weight: about 47 kg (103.6 lb)

**NOTE:** When mounting travel motor to transmission, install O-ring to travel motor first.

**NOTE:** Do not reuse O-ring.

Figure 105

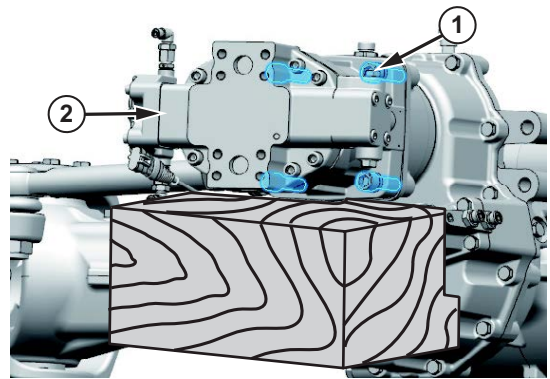

DS2105565

## Installation

1. Perform installation in the reverse order to removal.
2. When installing the hoses, install the drain hose as first.

# Driveshaft

## Repair Procedure Quick Guide

Step-A. Place the machine in the suitable service position

Step-B. Remove drive shaft

## Removal

### Drive Shaft

1. Remove mounting bolts (1).

- Tool: 14 mm (  )
- Torque: 68.6 N.m (7 kg.m, 50.6 ft lb)

**NOTE:** Apply adhesive (Loctite #262) to the mounting bolt.

2. Remove drive shaft (2) from axle and transmission.

## Installation

1. Perform installation in the reverse order to removal.

Figure 106

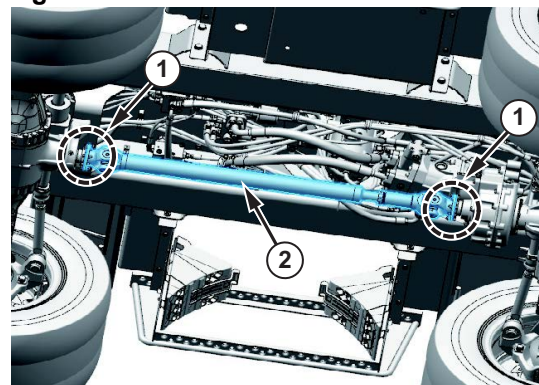

DS2105562



# Air Condenser Filter

## Repair Procedure Quick Guide

Step-A. Open the door.

Step-B. Recover the refrigerant.

Step-C. Remove air condenser filter

Step-D. Remove zeolite

## Removal

1. Open the door.
2. Turn OFF the battery disconnect switch.
3. Recover the refrigerant. Refer to Refrigerant Recovery.

## Air Condenser Filter

1. Remove plug with filter (1) from air condenser (2).

- Tool: 14 mm ()
- Torque: 3.23 N.m (33 kg.m, 2.39ft lb)

Figure 107



DS2002927

2. Remove air condenser filter (1).

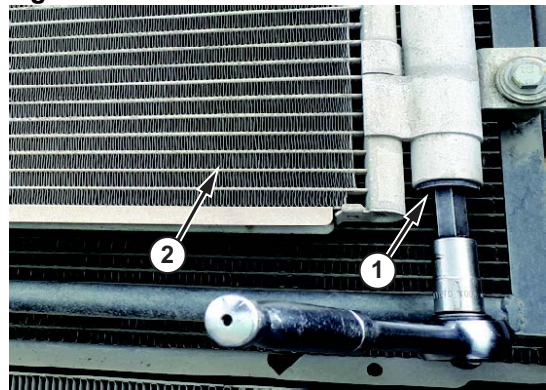
**NOTE:** Do not reuse air condenser filter.

**NOTE:** Check that the O-ring (2) are fitted to filter when installing

**NOTE:** Plug at the air condenser to prevent dirt or dust from entering.

Figure 108

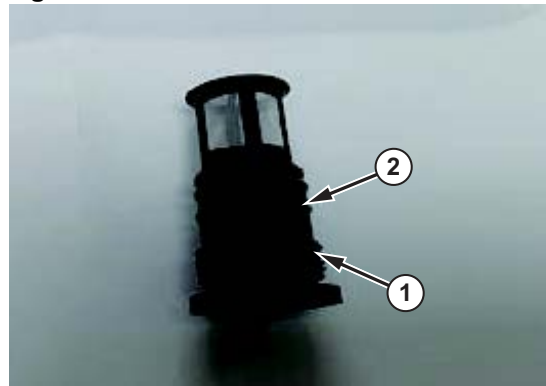

DS2002928

3. Remove zeolite (1) from air condenser.

**NOTE:** Be careful not to let water get into zeolite.

## Installation

1. Perform installation in the reverse order to removal.

Figure 109

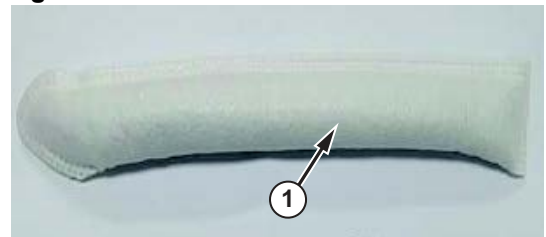

DS2002929

# Electric and Electronic

# Safety Instructions

---

## **WARNING**

---

### AVOID DEATH OR SERIOUS INJURY

Instructions are necessary before operating or servicing machine. Read and understand the Operation & Maintenance Manual and signs (decals) on machine. Follow warnings and instructions in the manuals when making repairs, adjustments or servicing. Check for correct function after adjustments repairs or service. Untrained operators and failure to follow instructions can cause death or serious injury.

---

# Table of Contents

## Electric and Electronic

Safety Instructions .....	64
Before Removing and Installing .....	67
Preparatory Work .....	67
General Precaution .....	67
Completing Work .....	67
Battery Assembly .....	68
Repair Procedure Quick Guide .....	68
Removal .....	68
Installation .....	69
EPOS Controller .....	70
Repair Procedure Quick Guide .....	70
Removal .....	70
Installation .....	70
TMS Controller .....	71
Repair Procedure Quick Guide .....	71
Removal .....	71
Installation .....	71
AVM Controller .....	72
Repair Procedure Quick Guide .....	72
Removal .....	72
Installation .....	72
Cabin Photo Sensor .....	73
Repair Procedure Quick Guide .....	73
Removal .....	73
Installation .....	73
Cabin Switches .....	74
Repair Procedure Quick Guide .....	74
Removal .....	74
Installation .....	76
Display Monitor .....	77
Repair Procedure Quick Guide .....	77
Removal .....	77
Installation .....	77
Hour Meter .....	78
Repair Procedure Quick Guide .....	78
Removal .....	78
Installation .....	78
Wiper Motor .....	79

Repair Procedure Quick Guide . . . . .	79
Removal . . . . .	79
Installation . . . . .	80
Combination Switch.....	81
Repair Procedure Quick Guide . . . . .	81
Removal . . . . .	81
Installation . . . . .	81

# Before Removing and Installing

## Preparatory Work

1. Park the machine on level ground. And lower front attachment to the ground.
2. Set parking brake switch to the parking position and then stop the engine.
3. Support the wheel chock to tire.
4. Move safety lever to "LOCK" position and then stop the engine.
5. Turn battery disconnect switch to "OFF" position.
6. Release the remaining pressure in the hydraulic circuit.
7. Cool down the hydraulic system and engine.
8. Attach a maintenance warning tag on controls.

Figure 110

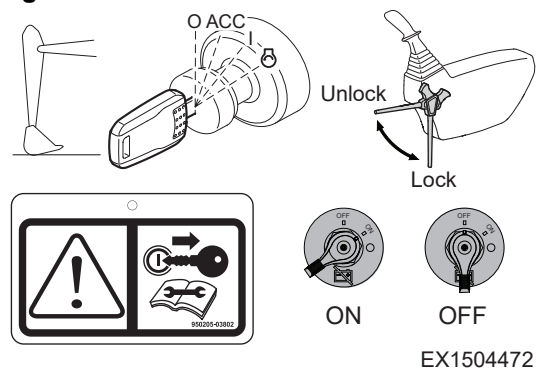

## General Precaution

1. Always read the safety section before removing and installing.
2. Mark the location of the bolts before removing.
3. Keep in the mind the order for tightening bolts.
4. Tighten bolts by hands, then using the tool.
5. If reusing the bolts, clean threads and apply thread locker to threads prior to installation.
6. Mark the location of wire harness connectors and hoses before disconnecting.
7. Be careful not to damage all components.
8. Do not reuse gaskets, O-ring and adhesive bolts.

Figure 111

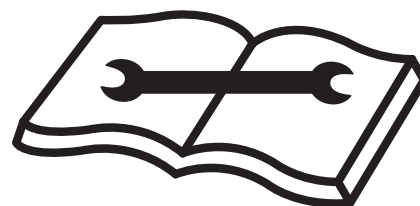

DS1901903

## Completing Work

1. Check oil, coolant and fuel leak from the machine.
2. Check all oil level and if necessary, add oil.
3. Fill up the fuel tank to the standard level.
4. Apply grease to all lubrication points.
5. When fuel component has been disconnected, air must be bled from circuit.  
For details, see the Operation and Maintenance Manual.
6. When hydraulic component has been disconnected, air must be bled from circuit.  
For details, see the Operation and Maintenance Manual.
7. Start the engine and run at low idle for about 5 minutes.
8. Perform the machine performance test.

# Battery Assembly

## Repair Procedure Quick Guide

Step-A. Remove battery cover

Step-B. Remove battery assembly

### Removal

1. Turn OFF the battery disconnect switch.

#### Battery Cover

1. Remove mounting bolts (1) and battery cover (2) from frame.

- Tool: 19 mm (  )
- Torque: 107.8 N.m (11 kg.m, 79.5 ft lb)

Figure 112



DS2105481

2. Open side door.

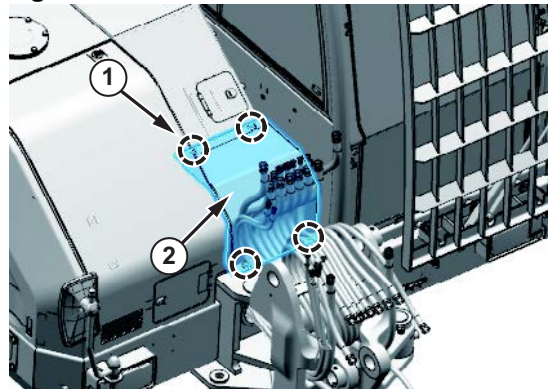
Figure 113

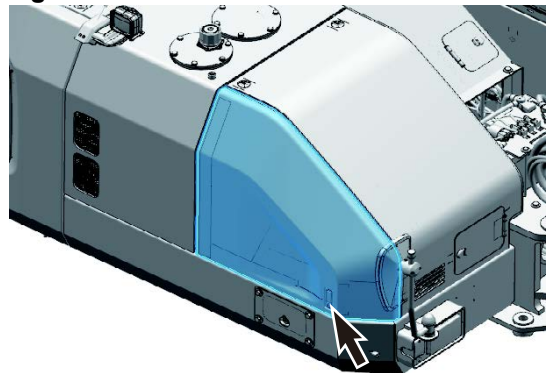

DS2105482

3. Remove mounting bolts (1) and fuel tank cover (2) from frame.

- Tool: 19 mm (  )
- Torque: 107.8 N.m (11 kg.m, 79.5 ft lb)

Figure 114



DS2105483

## Battery Assembly

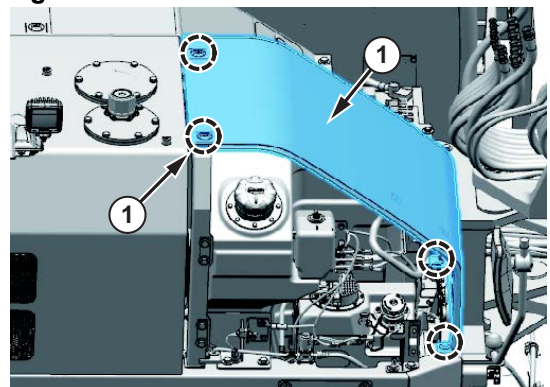
1. Disconnect the negative cable (1) and positive cable (2) from the battery.
2. Disconnect wire harness connector (3).
3. Disconnect the nut and cable (4).
4. Remove mounting bolts (5) and battery mounting bracket.

- Tool: 17 mm (  )

**NOTE:** Do not tighten the fasteners too hard when installing.

5. Remove battery assembly.

## Installation

1. Perform installation in the reverse order to removal.

Figure 115

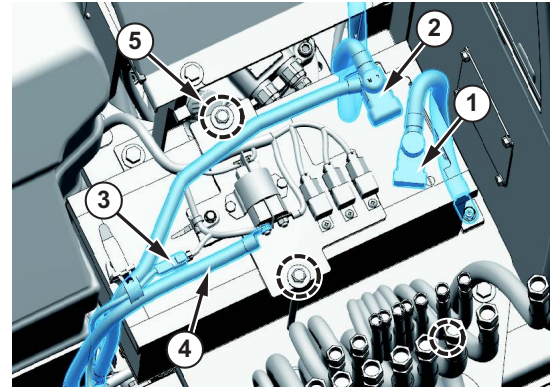

DS2105488



# EPOS Controller

## Repair Procedure Quick Guide

Step-A. Open the cabin door

Step-B. Remove cabin rear cover

Step-C. Disconnect wiring harness

Step-D. Remove EPOS controller

## Removal

1. Turn OFF the battery disconnect switch.
2. Open the cabin door.
3. Fold the seat backrest forward.
4. For details, refer to Operation Manual.  
Move the seat assembly forward.

### Cabin Rear Cover

1. Remove bolts (1) from cabin rear cover.
  - Tool: 10 mm (  )
2. Remove screws (2) from cabin rear cover.
3. Remove cabin rear cover (3) from cabin assembly.

Figure 116



DS2001550

### EPOS Controller

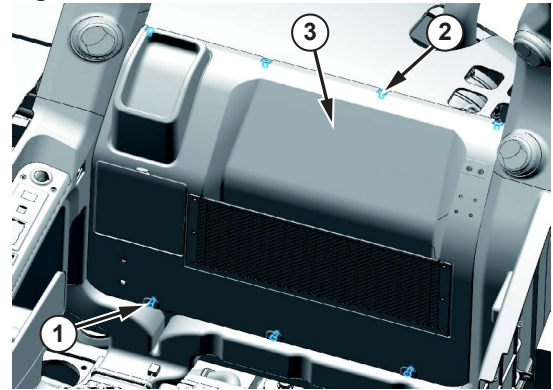
1. Disconnect wiring harness connectors (1) from EPOS controller.  
**NOTE:** Move up connector levers when disconnect.
2. Remove mounting bolts (2) from EPOS controller.
  - Tool: 13 mm (  )
  - Torque: 19.6 N.m (2 kg.m, 14.5 ft lb)
3. Remove EPOS controller (3).

Figure 117



DS2001551

## Installation

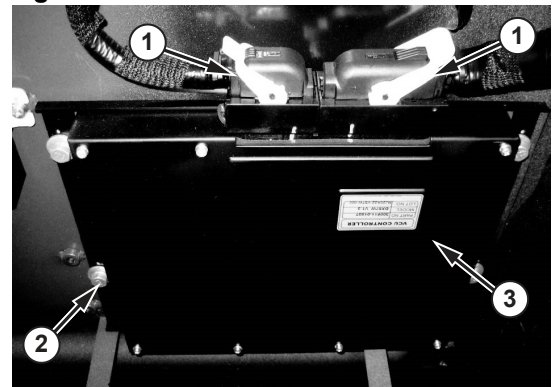
1. Perform installation in the reverse order to removal.

# TMS Controller

## Repair Procedure Quick Guide

- Step-A. Open the cabin door
- Step-B. Remove cabin rear cover
- Step-C. Disconnect wiring harness
- Step-D. Remove TMS controller

## Removal

1. Turn OFF the battery disconnect switch.
2. Open the cabin door.
3. Fold the seat backrest forward.
4. For details, refer to Operation Manual.  
Move the seat assembly forward.

### Cabin Rear Cover

1. Remove bolts (1) from cabin rear cover.
  - Tool: 10 mm (  )
2. Remove screws (2) from cabin rear cover.
3. Remove cabin rear cover (3) from cabin assembly.

Figure 118



DS2001550

### TMS Controller

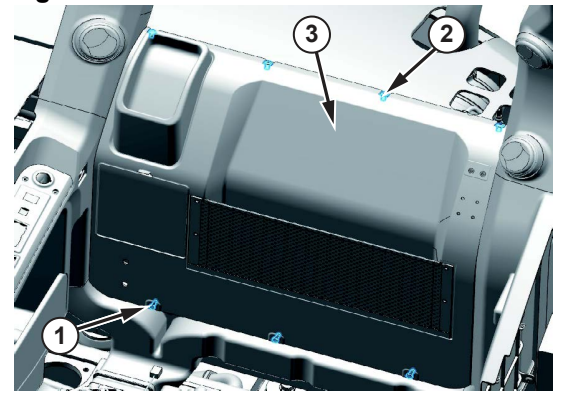
1. Disconnect wiring harness (1) and cables (2) from TMS controller.  
**NOTE:** Check the location of the connectors before disconnecting.
2. Remove mounting bolts (3) from TMS controller.
3. Loosen mounting bolts (4).  
**NOTE:** Do not tighten the fasteners too hard when installing.
4. Remove TMS controller.  
**NOTE:** Check the “UP” mark on the TMS controller. “UP” mark upward when TMS controller is mounted to the machine.

Figure 119

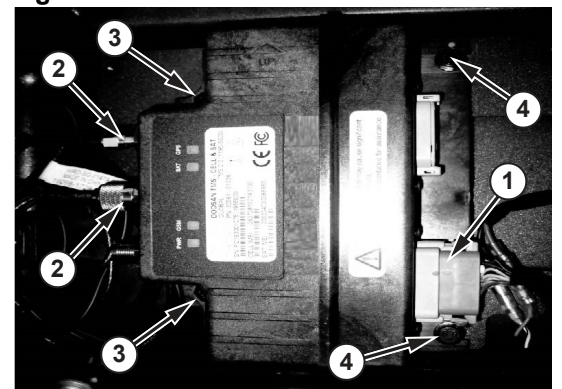

DS2001552

## Installation

1. Perform installation in the reverse order to removal.

# AVM Controller

## Repair Procedure Quick Guide

Step-A. Open the cabin door

Step-B. Remove cabin rear cover

Step-C. Disconnect wiring harness

Step-D. Remove AVM controller

## Removal

1. Turn OFF the battery disconnect switch.
2. Open the cabin door.
3. Fold the seat backrest forward.
4. Move the seat assembly forward.

For details, refer to Operation Manual.

## Cabin Rear Cover

1. Remove bolts (1) from cabin rear cover.
  - Tool: 10 mm (  )
2. Remove screws (2) from cabin rear cover.
3. Remove cabin rear cover (3) from cabin assembly.

Figure 120



DS2001550

## AVM Controller

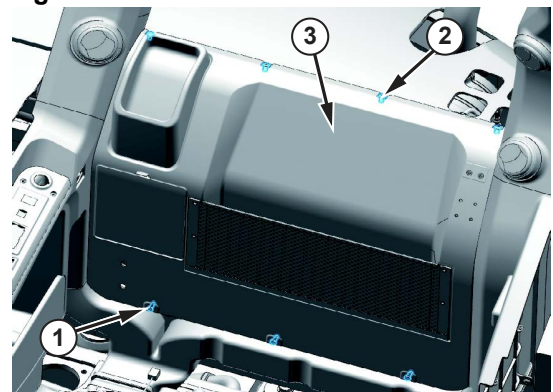
1. Disconnect wiring harness connector (1) and all connectors from AVM controller.

**NOTE:** Check the location of the connectors before disconnecting.

2. Remove mounting screws (2) from AVM controller mounting bracket.
3. Remove AVM controller (3).

Figure 121

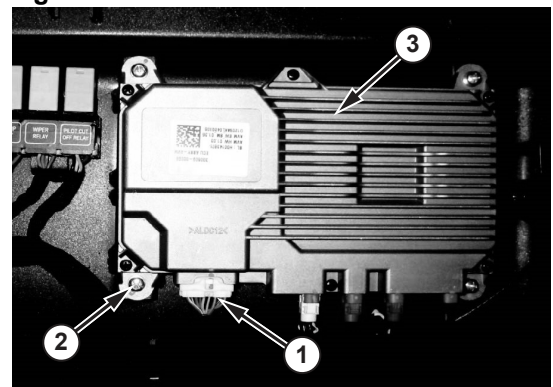

DS2001554

## Installation

1. Perform installation in the reverse order to removal.

# Cabin Photo Sensor

## Repair Procedure Quick Guide

Step-A. Open the cabin door

Step-B. Remove cabin photo sensor

### Removal

1. Turn OFF the battery disconnect switch.
2. Open the cabin door.

### Cabin Photo Sensor

1. Pull up cabin photo sensor (1) by using a flat-head screwdriver.

**NOTE:** Please find the service groove.

2. Disconnect wiring harness connector (2) from cabin photo sensor.
3. Remove cabin photo sensor (1).

### Installation

1. Perform installation in the reverse order to removal.

**Figure 122**

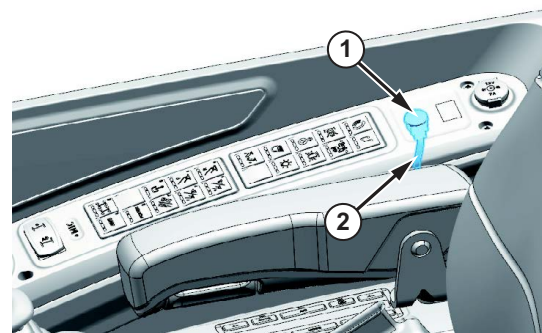

DS2105475

# Cabin Switches

## Repair Procedure Quick Guide

Step-A. Open the cabin door

Step-B. Remove cabin side upper cover

Step-C. Remove stand upper cover

Step-D. Disconnect wiring harness

Step-E. Remove cabin switches

## Removal

1. Turn OFF the battery disconnect switch (2).

2. Open the cabin door.

### Cabin Side Upper Cover

1. Remove mounting screws (1) from cabin side cover.

2. Remove cabin side cover (2).

Figure 123

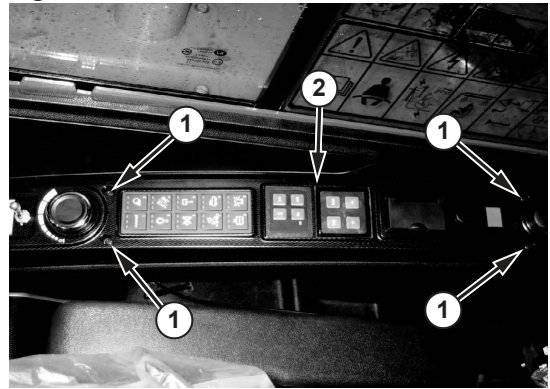

DS2001555

### Cabin Switches

1. Disconnect wire harness and screws from starter switch

2. Remove lock nut and starter switch (1).

3. Disconnect wire harness from quick coupler switch.

4. Remove lock nut and quick coupler switch. (2).

5. Disconnect wire harness from engine speed control dial.

6. Remove mounting screws and engine speed control dial (3).

7. Disconnect wire harness from key pad.

8. Remove mounting nuts and key pad (4).

9. Disconnect wire harness from bluetooth control panel.

10. Remove bluetooth control panel (5).

11. Disconnect wire harness from audio control panel.

12. Remove audio control panel (6).

13. Disconnect wire harness from jack assembly.

14. Remove jack assembly (7).

Figure 124

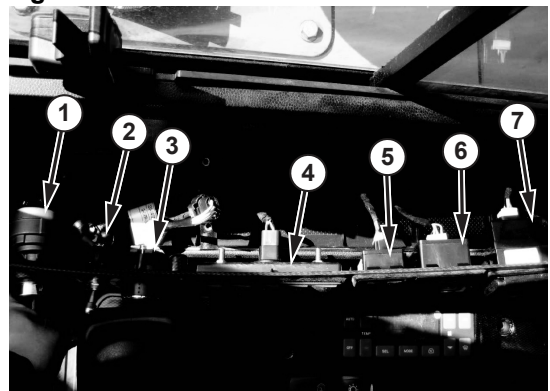

DS2001556

### Stand Upper Cover - Right Side

1. Remove cap and mounting screws (1) from stand upper cover.
2. Remove stand upper cover (2).

Figure 125

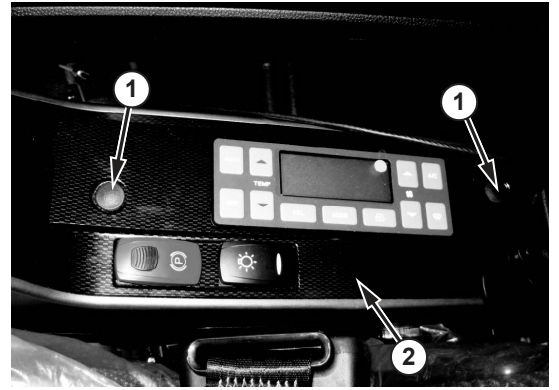

DS2001557

### Cabin Switches

1. Disconnect wire harness from switches.
2. Pull up cabin switches (1) by using a flat-head screwdriver.

**NOTE:** *Be careful not to break the switch assembly.*

- Parking brake switch
- Light switch

Figure 126

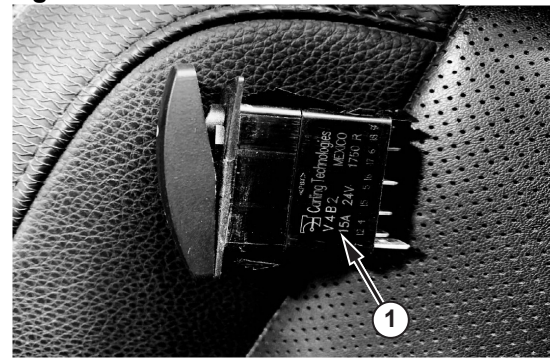

DS1901319

3. Remove mounting screws (1) from bracket.
4. Remove HVAC control panel (2) from stand.
5. Disconnect wire harness from HVAC control panel.

Figure 127

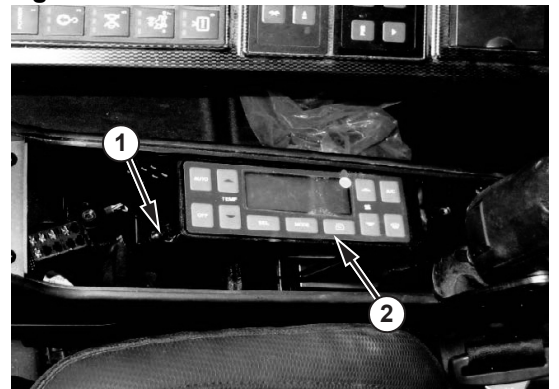

DS2001558

### Stand Upper Cover - Left Side

1. Remove dozer blade control lever knob (1).
2. Remove mounting bolt and grip (2).
3. Remove cap and mounting screws (3) from stand upper cover.
4. Remove stand upper cover (4).

Figure 128

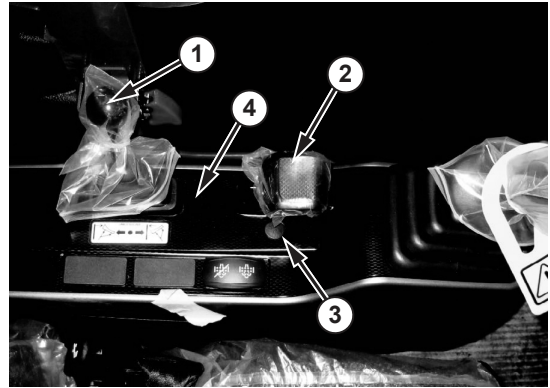

DS2001559

### Cabin Switches

1. Disconnect wire harness from switches.
2. Pull up cabin switches (1) by using a flat-head screwdriver.

**NOTE:** *Be careful not to break the switch assembly.*

- Aftertreatment system switch

### Installation

1. Perform installation in the reverse order to removal.

Figure 129

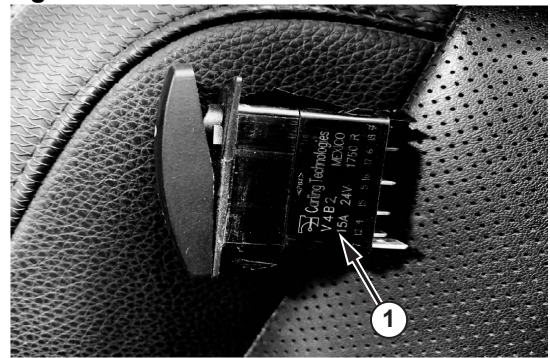

DS1901319

# Display Monitor

## Repair Procedure Quick Guide

Step-A. Open the cabin door

Step-B. Remove display monitor

### Removal

1. Turn OFF the battery disconnect switch.

#### Display Monitor

1. Open the cabin door.
2. Disconnect wiring harness (1) from display monitor (3).
3. Remove mounting screws (2) from bracket.
4. Remove display monitor (3).

### Installation

1. Perform installation in the reverse order to removal.

Figure 130

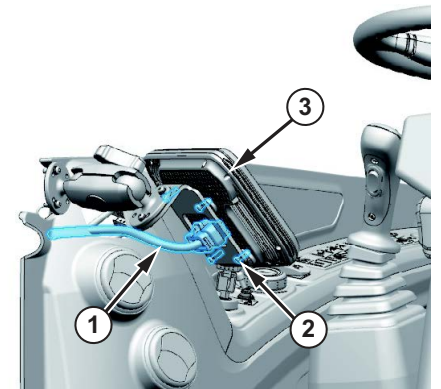

DS2105476



# Hour Meter

## Repair Procedure Quick Guide

Step-A. Open the cabin door

Step-B. Remove cabin side cover

Step-C. Remove hour meter

## Removal

1. Turn OFF the battery disconnect switch.
2. Open the cabin door.

### Cabin Side Cover

1. Remove mounting screws (1) from cabin side cover.
2. Remove the cabin side cover (2).

Figure 131

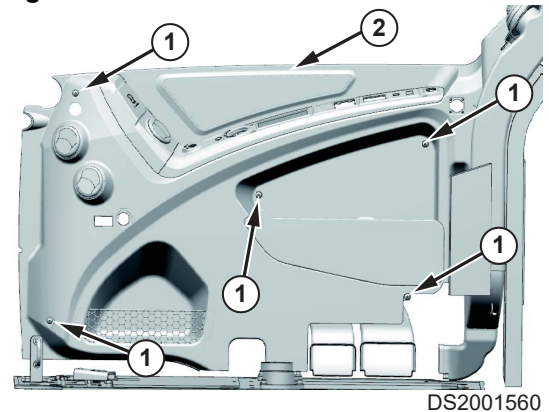

### Hour Meter

1. Disconnect the wire harnesses.
2. Remove the fastener from hour meter.
3. Remove the hour meter (1) from cabin side cover.

### Installation

1. Perform installation in the reverse order to removal.

Figure 132

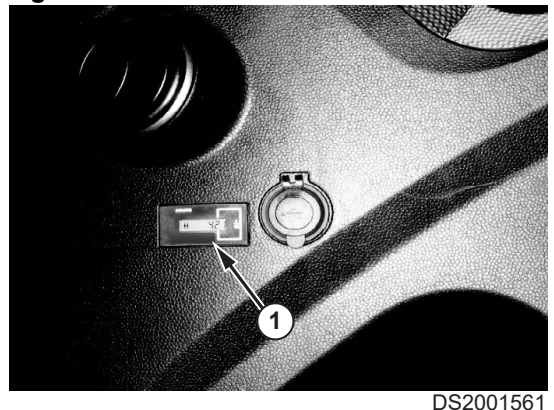

# Wiper Motor

## Repair Procedure Quick Guide

Step-A. Remove wiper arm and blade

Step-B. Remove undercover

Step-C. Disconnect wire harness

Step-D. Remove wiper motor

## Removal

1. Turn OFF the battery disconnect switch.

### Wiper Arm and Blade

1. Remove caps (1) from wiper arm.

Figure 133

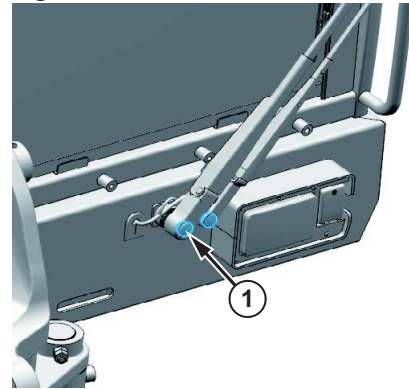

DS2105477

2. Remove mounting nut (1).

- Tool: 17 mm (  )
- Torque: 55 N.m (5.6 kg.m, 40.5 ft lb)

3. Remove mounting nut (2).

- Tool: 14 mm (  )
- Torque: 40 N.m (4.1 kg.m, 29.5 ft lb)

4. Disconnect the washer hose from wiper arm.

5. Remove cap plug.

6. Remove the wiper arm and blade from frame.

Figure 134

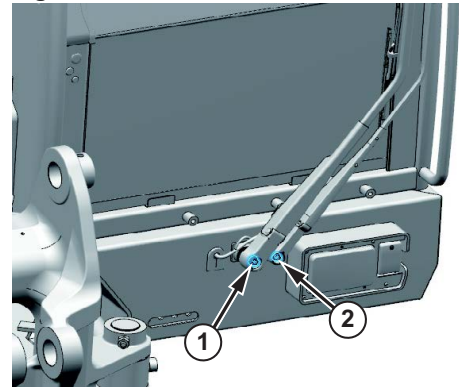

DS2105479

## Undercover

1. Remove the undercover (A).

For details, refer to [Undercovers - Removal and Installation.](#)

Figure 135

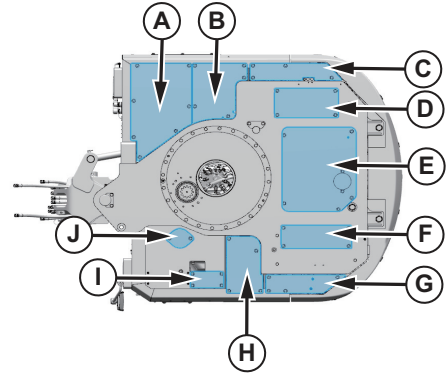

DS2105465

## Wiper Motor

1. Remove mounting nut (1).

- Tool: 32 mm (  )
- Torque: 57 N.m (5.8 kg.m, 42 ft lb)

Figure 136



DS2105480

2. Disconnect the wire harness connector from wiper motor.
3. Remove nuts (1) and bolts (2) frame.
4. Remove wiper motor (3) frame.

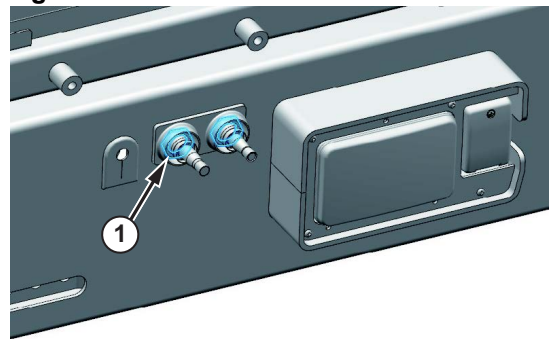
## Installation

1. Perform installation in the reverse order to removal.

Figure 137

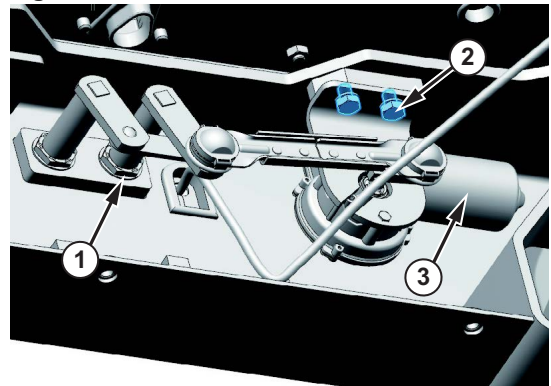

DS2105478

# Combination Switch

## Repair Procedure Quick Guide

Step-A. Open the cabin door

Step-B. Remove steering column cover

Step-C. Disconnect wiring harness

Step-D. Remove combination switch

## Removal

1. Turn OFF the battery disconnect switch.
2. Open the cabin door.
3. Fold the seat backrest forward.
4. Move the seat assembly forward.

For details, refer to Operation Manual.

## Steering Column Cover

1. Remove screws (1) and steering column cover (2).

Figure 138

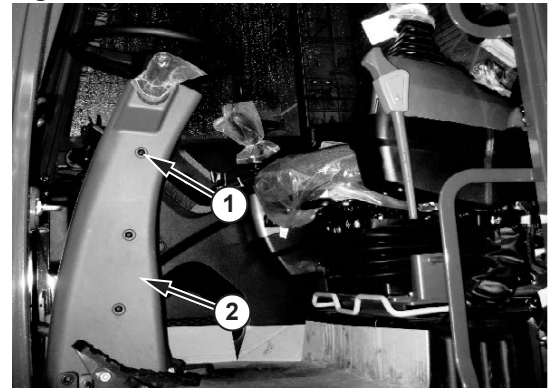

DS2001573

## Combination Switch

1. Disconnect wire harness (1) from combination switch.
2. Remove bolts (2) and combination switch (3).

## Installation

1. Perform installation in the reverse order to removal.

Figure 139

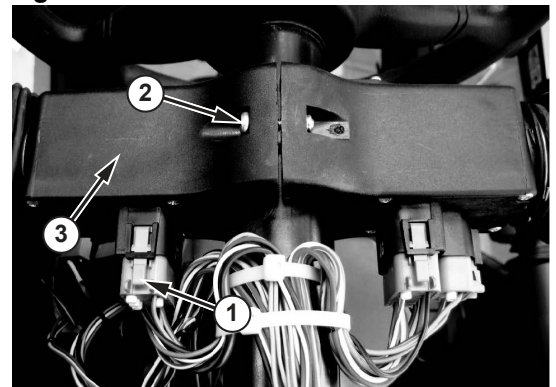

DS2001575



# Troubleshooting Guide



# Troubleshooting





# Wiring Harness Layout

# Safety Instructions

---

## **WARNING**

---

### AVOID DEATH OR SERIOUS INJURY

Instructions are necessary before operating or servicing machine. Read and understand the Operation & Maintenance Manual and signs (decals) on machine. Follow warnings and instructions in the manuals when making repairs, adjustments or servicing. Check for correct function after adjustments repairs or service. Untrained operators and failure to follow instructions can cause death or serious injury.

---

# Table of Contents

## Wiring Harness Layout

Safety Instructions .....	6
WIRING DEVICE.....	8
Wiring Harness Layout .....	8
Main Harness (1/2) .....	9
Main Harness (2/2) .....	10
Cabin Harness.....	11
Undercarriage Harness .....	12
Engine Harness.....	13
Battery Harness.....	14

# WIRING DEVICE

## Wiring Harness Layout

Figure 1

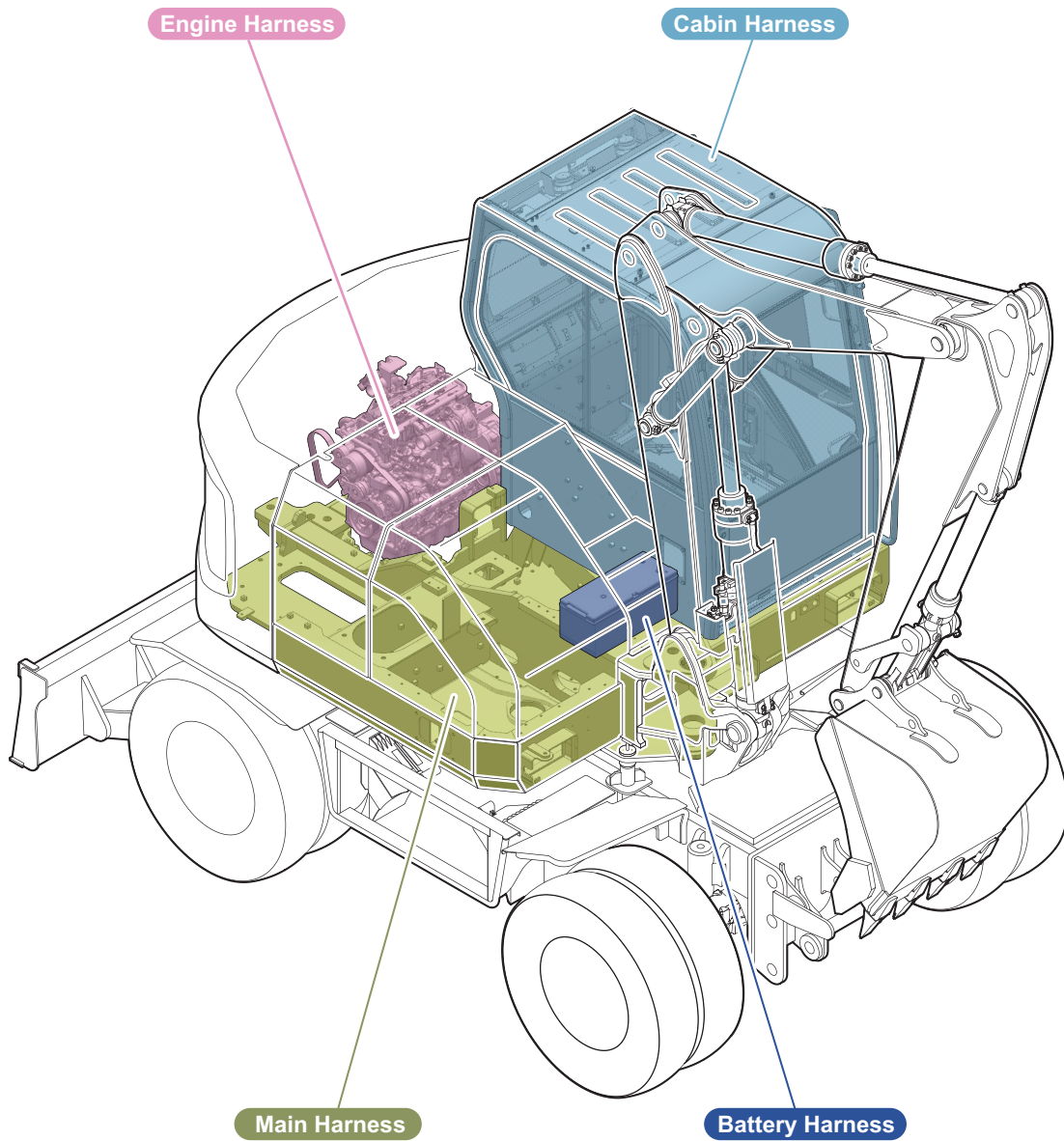

DS2105036

# Main Harness (1/2)

Figure 2

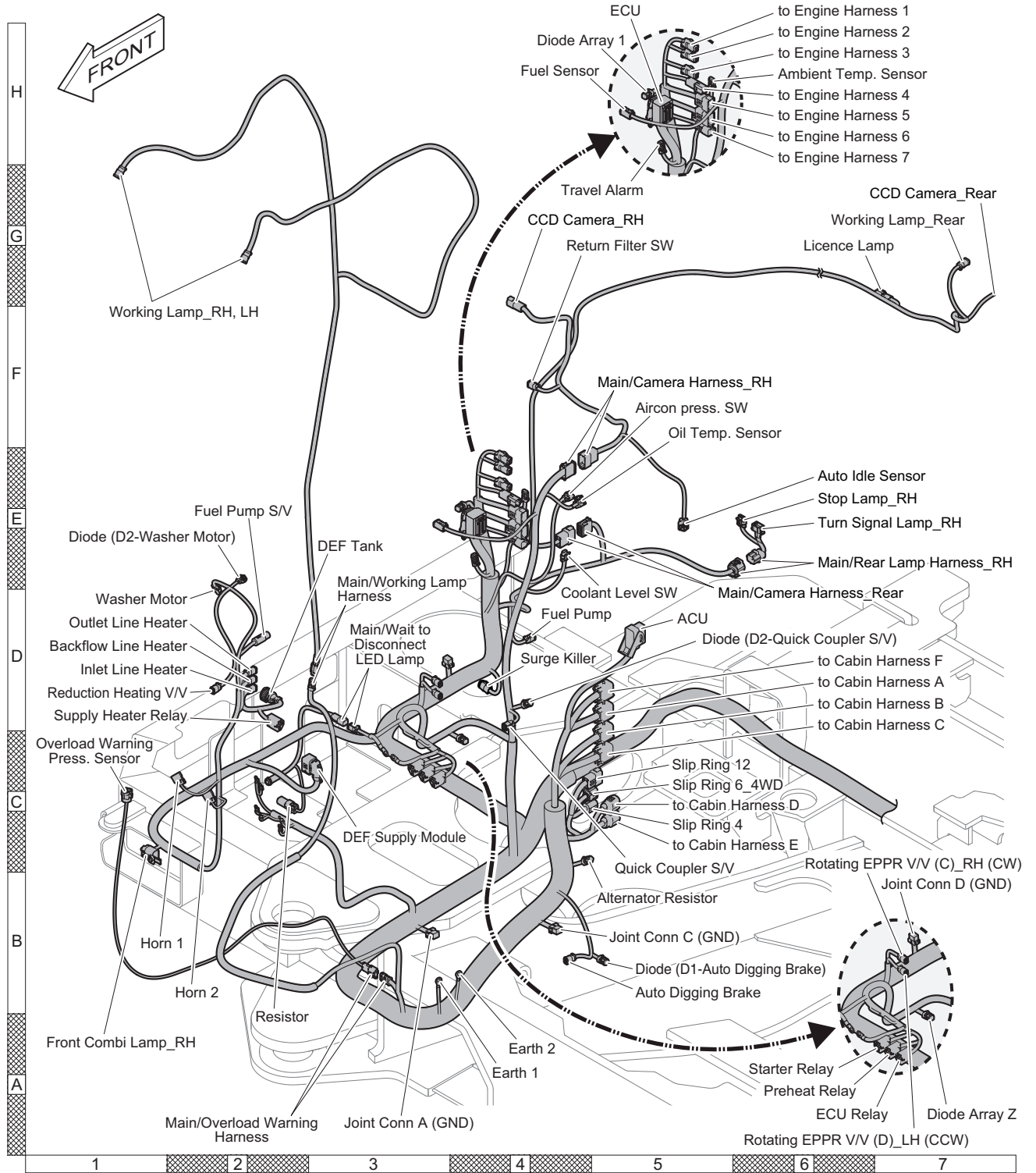

DS2105037

# Main Harness (2/2)

Figure 3

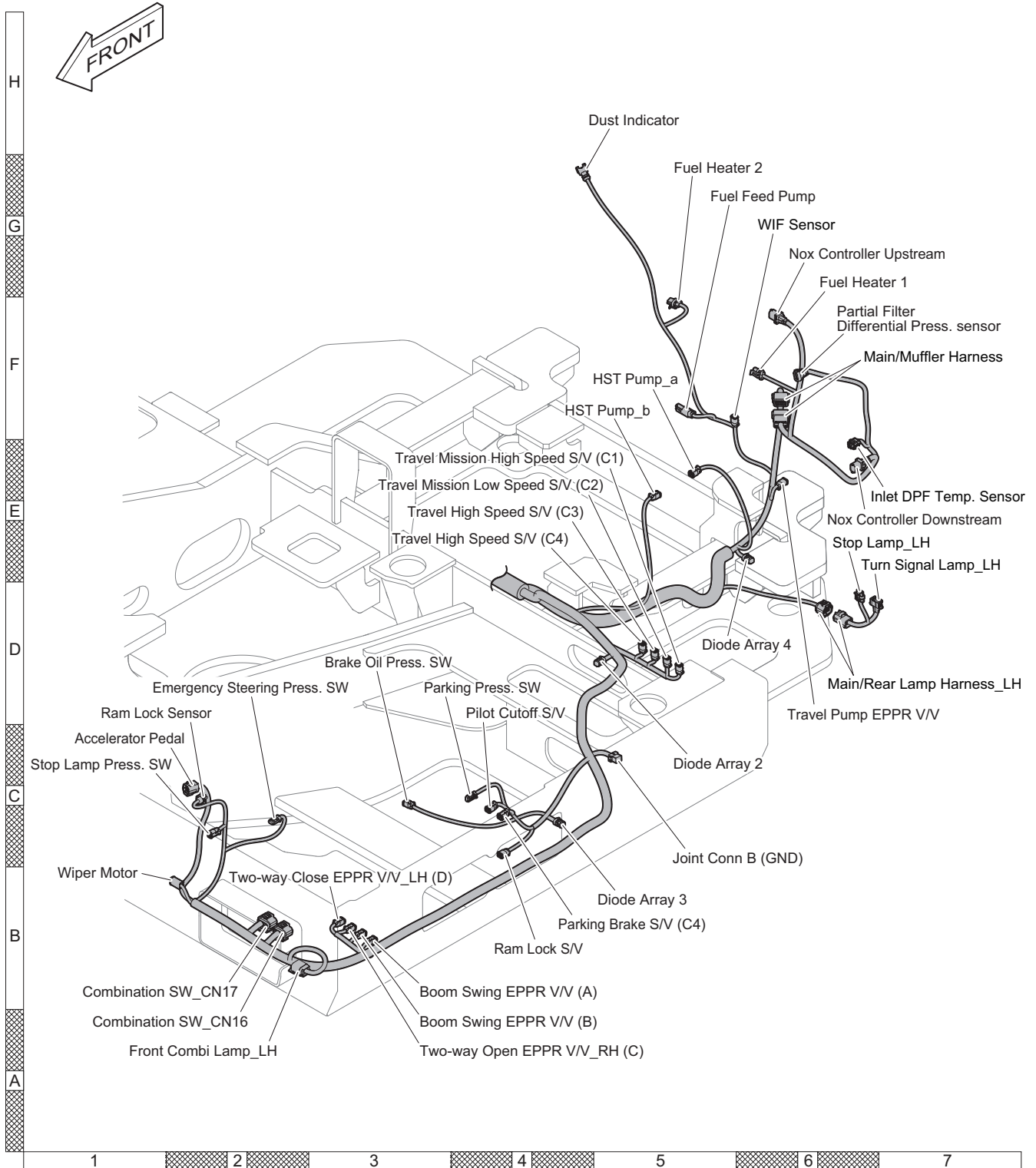

DS2105038

# Cabin Harness

Figure 4

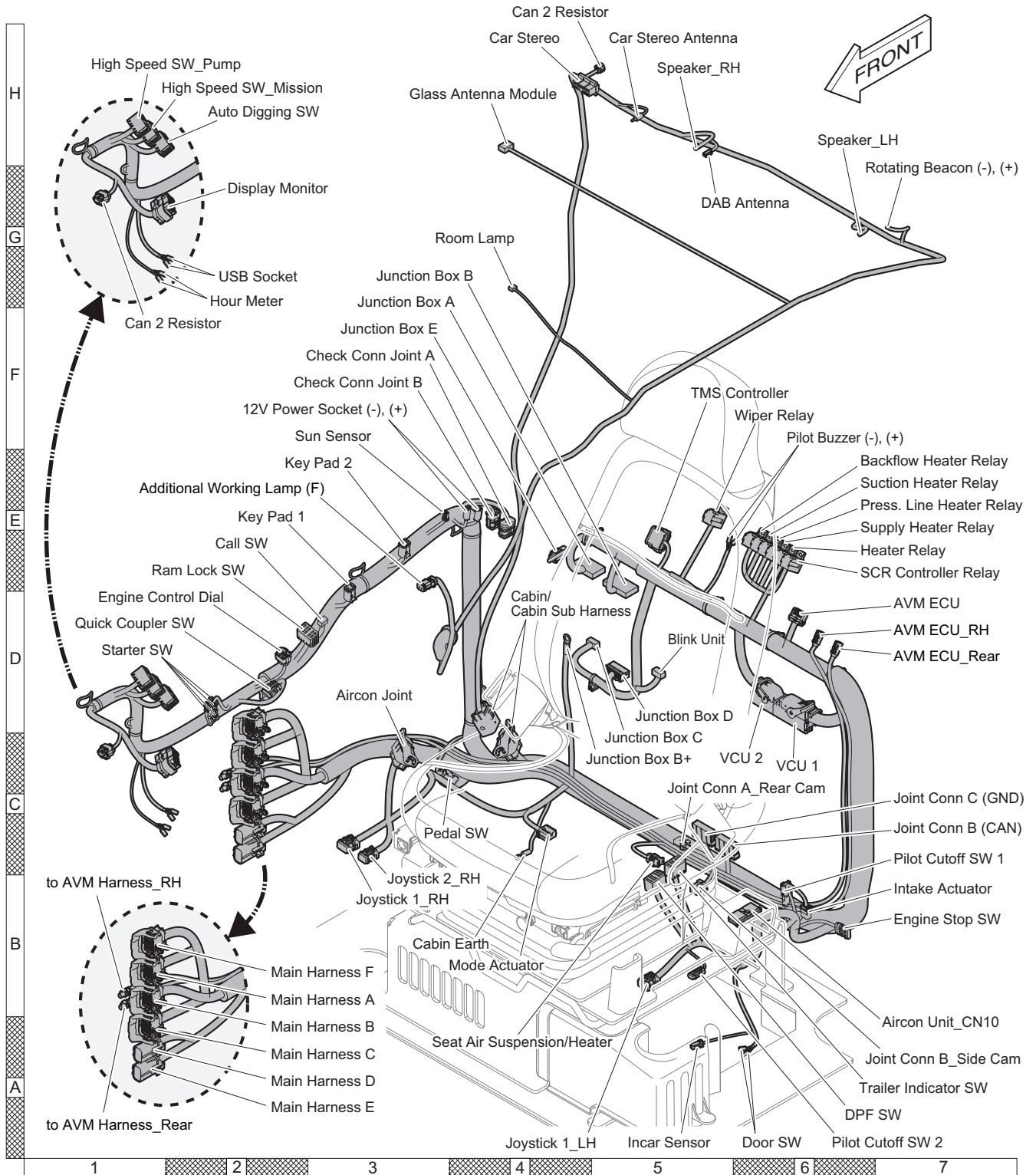

DS2105039



# Undercarriage Harness

Figure 5

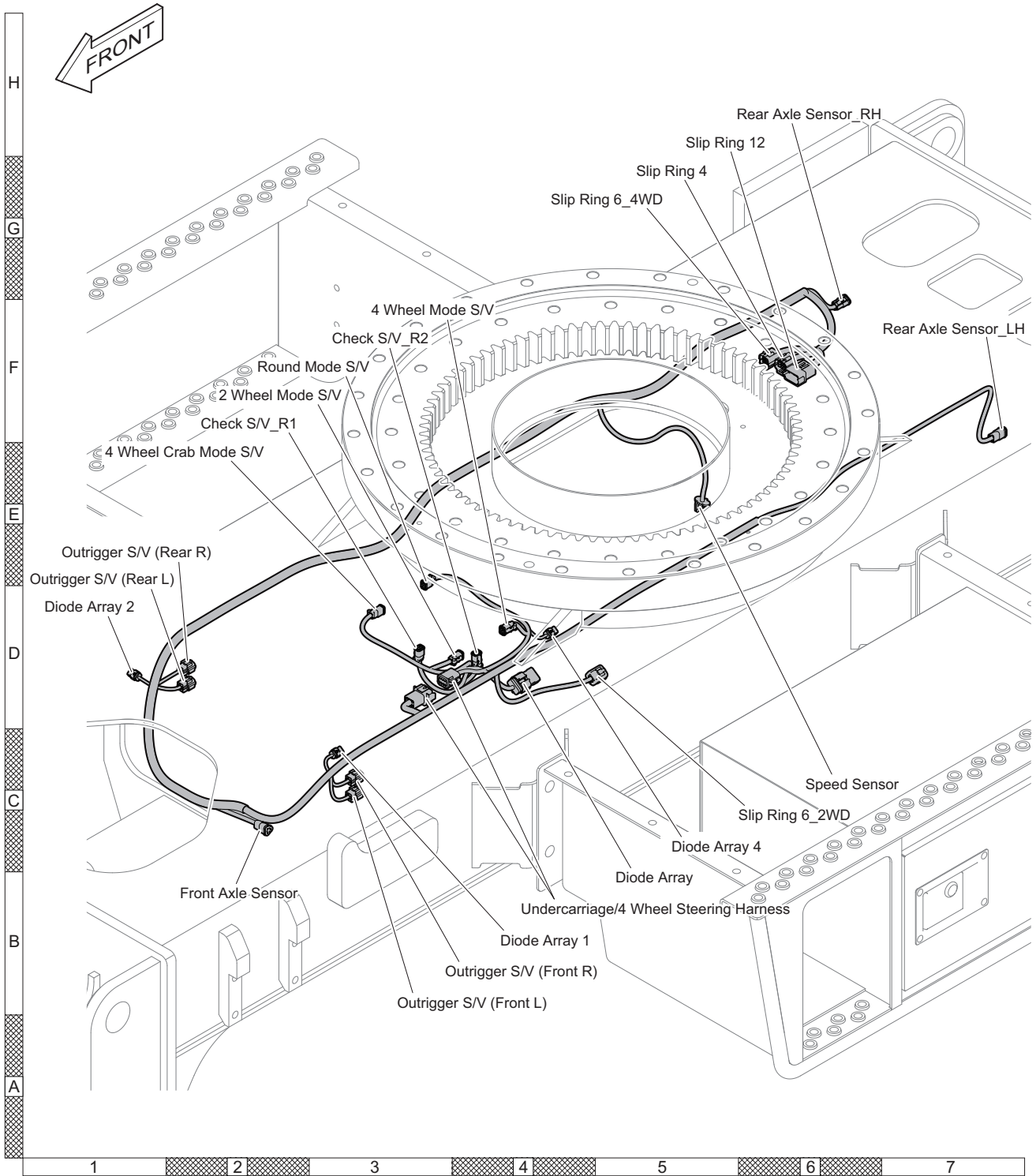

DS2105040

# Engine Harness

Figure 6

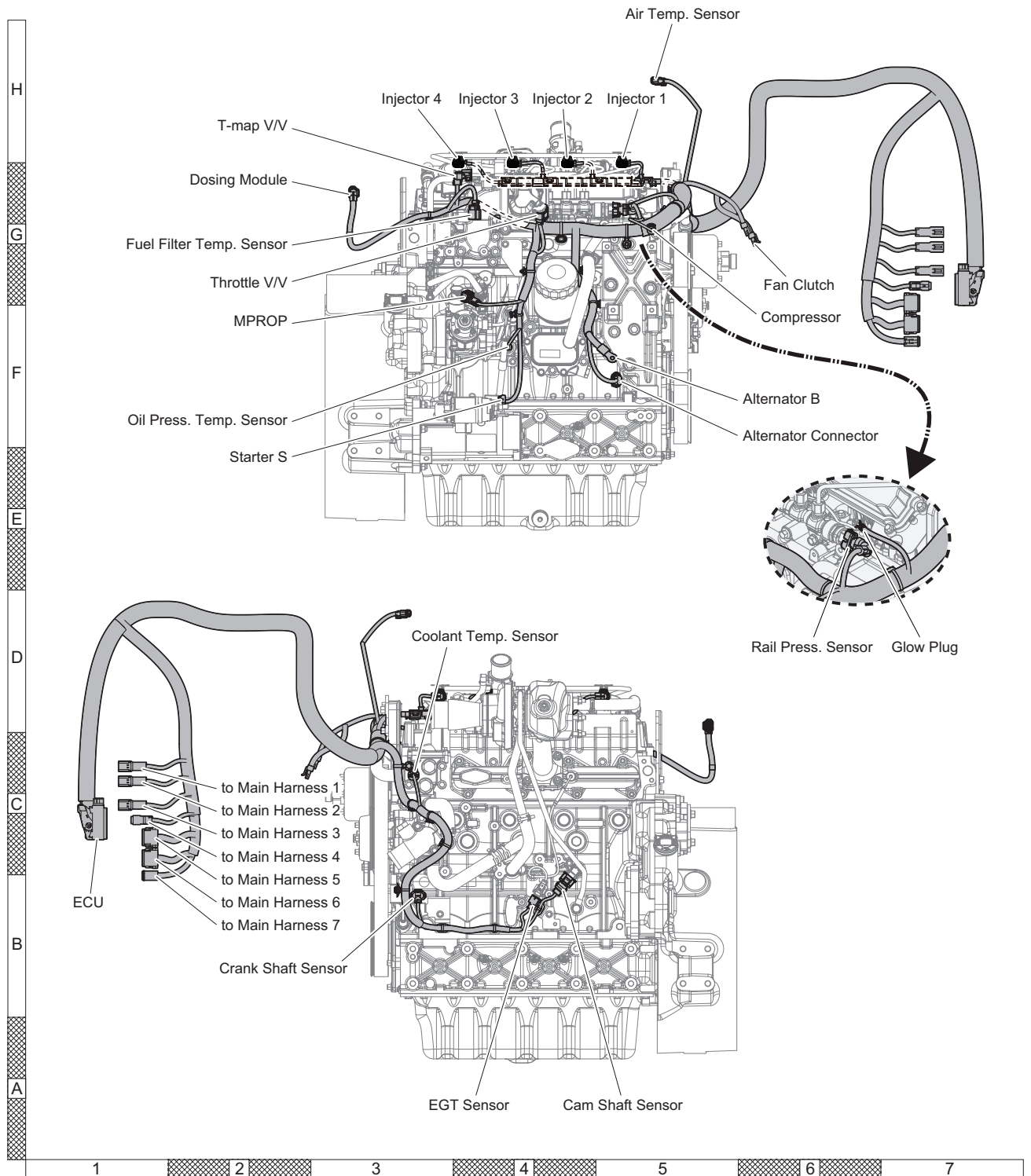

DS2105041

# Battery Harness

Figure 7

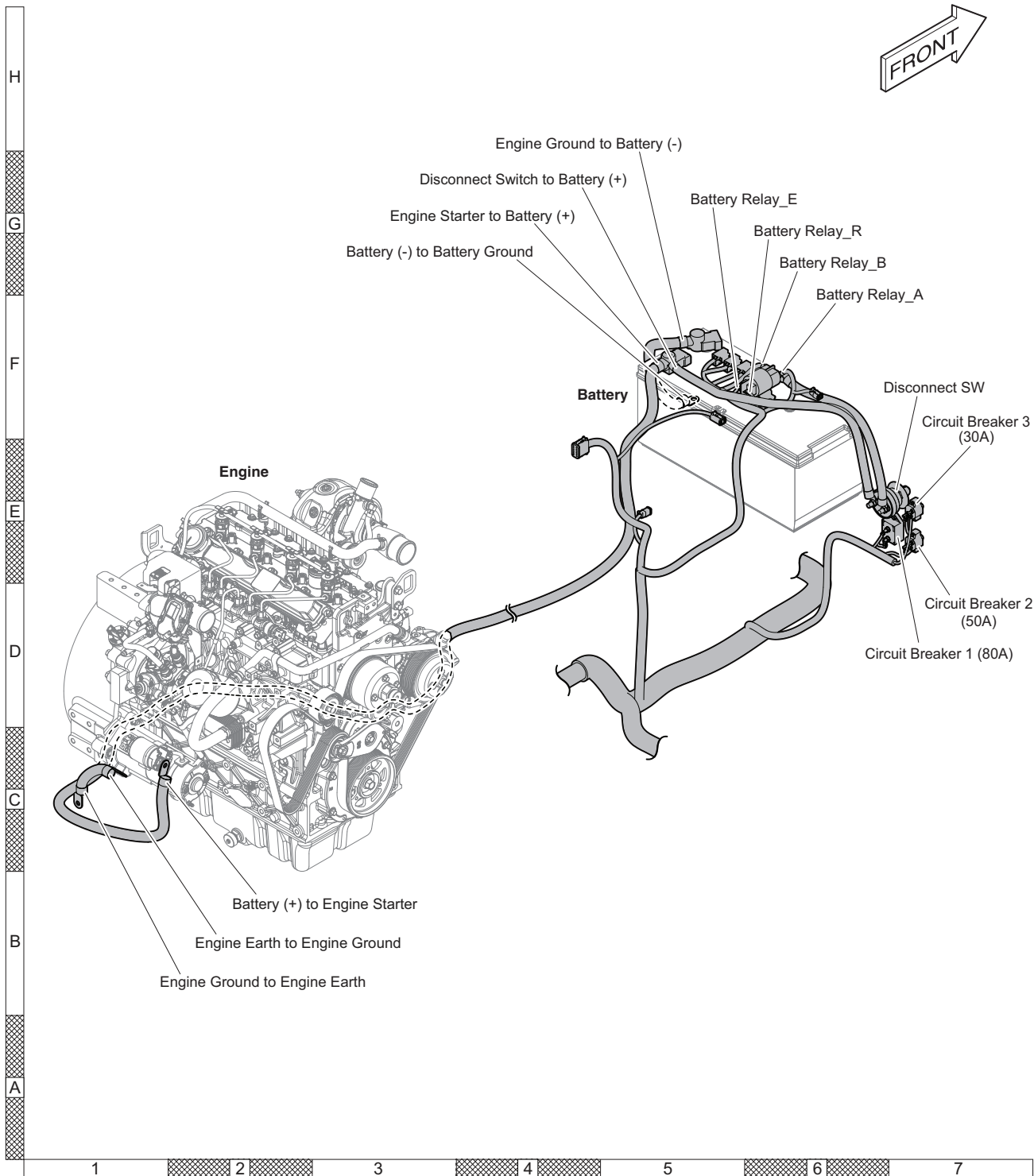

DS2105042

# Error Code

# Safety Instructions

---

## **WARNING**

---

### AVOID DEATH OR SERIOUS INJURY

Instructions are necessary before operating or servicing machine. Read and understand the Operation & Maintenance Manual and signs (decals) on machine. Follow warnings and instructions in the manuals when making repairs, adjustments or servicing. Check for correct function after adjustments repairs or service. Untrained operators and failure to follow instructions can cause death or serious injury.

---

# Table of Contents

## Error Code

Safety Instructions 16

EPOS ERROR CODE 18

1. Engine Fault Code List 20

# EPOS ERROR CODE

Information Mentioned in Troubleshooting Table

- The following information is summarized in the troubleshooting table and the related circuit diagram. Before performing troubleshooting, understand that information fully.

Before performing troubleshooting, understand that information fully. Please refer to the DMS-5 for detailed information.

No.		Description of the Problems
1	VCO001	Gauge Panel
2	VCO002	E-ECU
3	VPV007	Flow Control Proportional Valve (C) 2-way RH-Open
4	VPV008	Flow Control Proportional Valve (D) 2-way RH-Close
5	VPV009	Flow Control Proportional Valve (E) Rotating CW
6	VPV010	Flow Control Proportional Valve (F) Rotating CCW
7	VPV011	Travel Proportional Valve
8	VPV013	Flow Control Proportional Valve (A) Boom Swing CW
9	VPV014	Flow Control Proportional Valve (B) Boom Swing CCW
10	VSV009	Forward Solenoid Valve (G)
11	VSV010	Reverse Solenoid Valve (H)
12	VSV014	Low Speed Solenoid Valve
13	VSV015	High Speed Solenoid Valve
14	VSV037	Quick Coupler Solenoid Valve
15	VSV040	Travel Pump High Speed 1 Solenoid Valve
16	VSV041	Travel Pump High Speed 2 Solenoid Valve
17	VSV042	4Wheel Mode Solenoid Valve
18	VSV043	Crab Mode Solenoid Valve
19	VSV044	Round Mode Solenoid Valve
20	VSV045	2Wheel Mode Solenoid Valve
21	VSV046	R1 Check Mode Solenoid Valve
22	VSV047	R2 Check Mode Solenoid Valve
23	VSV048	Front RH Outrigger Solenoid Valve
24	VSV049	Front LH Outrigger Solenoid Valve
25	VSV050	Rear RH Outrigger Solenoid Valve
26	VSV051	Rear LH Outrigger Solenoid Valve
27	VSV052	TRAILER DUMP Solenoid Valve
28	VSV053	Boom LIS Head Solenoid Valve
29	VSV054	Boom LIS Rod Solenoid Valve
30	VSV055	Auto Digging Brake Solenoid Valve
31	VSV001	Breaker Operating Solenoid Valve
32	VSV002	Relief Pressure Up Solenoid Valve (B)
33	VSV003	High-speed Solenoid Valve (C)
34	VSV007	Option Safety Solenoid Valve

35	VSV011	2 Pump Select Solenoid Valve (I)
36	VSV037	Quick Coupler Solenoid Valve
37	VRY002	Back Buzzer Relay
38	VRY016	Auto Shut Off Relay
39	VRY018	ACC Relay
40	VGC003	External Voice Warning Signal
41	VGC004	Wiper Operating Signal
42	VSP001	Front Pump Pressure(P2) Sensor
43	VSP002	Rear Pump Pressure(P1) Sensor
44	VSP003	Overload Warning Pressure Sensor
45	VSP004	Px (Front) Pressure Sensor
46	VSP005	Py (Travel) Pressure Sensor
47	VSP006	Boom Up Pressure Sensor
48	VSP010	Arm In Pressure Sensor
49	VSP014	Swing Pressure Sensor
50	VSP021	I-CEPT Sensor P1
51	VSP022	I-CEPT Sensor P2
52	VSE001	Oil Temperature Sensor
53	VSE002	Fuel Sensor
54	VSE004	WIF Sensor
55	VS5001	Thumb Wheel (RH)
56	VS5002	Thumb Wheel (LH)
57	VS5005	Dial
58	VS5006	Machine Controller +5 V Output 1
59	VS5007	Machine Controller +5 V Output 2
60	VAL001	Alternator Potential



# 1. Engine Fault Code List

Gauge Panel Fault Code	P Code	Fault Code Description
E000000-19	U0607	Timeout Error of CAN-Receive-Frame TSC1VE (Engine speed & Torque demand) - (U0607)
E000027-00	P042E	EGR Position Open jammed fault - (P042E)
E000027-01	P042F	EGR Position Closed jammed fault - (P042F)
E000027-03	P0406	EGR Position Sensor High Fault - (P0406)
E000027-04	P0407	EGR Position Sensor Low Fault - (P0407)
E000027-20	P0C17	EGR Close Position Learning Range Over Fault - (P0C17)
E000027-22	P0C18	EGR Close Position Learning Drift Fault for long time - (P0C18)
E000027-23	P0C19	EGR Close Position Learning Drift Fault for short time - (P0C19)
E000029-03	P0223	Accel pedal position track2 sensor High fault - (P0223)
E000029-04	P0222	Accel pedal position track2 sensor Low fault - (P0222)
E000029-15	P0221	Hand pedal position track2 sensor High fault - (P0221)
E000029-17	P0224	Hand pedal position track2 sensor Low fault - (P0224)
E000051-00	P02E4	Throttle valve Position Open jammed fault - (P02E4)
E000051-01	P02E5	Throttle valve Position Closed jammed fault - (P02E5)
E000051-03	P02E9	Throttle valve Position Sensor High Fault - (P02E9)
E000051-04	P02E8	Throttle valve Position Sensor Low Fault - (P02E8)
E000051-22	P02EA	Throttle valve Close Position Learning Drift Fault for long time - (P02EA)
E000051-23	P02EB	Throttle valve Close Position Learning Drift Fault for short time - (P02EB)
E000051-30	P02E7	Throttle valve Close Position Learning Range Over Fault - (P02E7)
E000091-03	P0123	Accel pedal position track1 sensor High fault - (P0123)
E000091-04	P0122	Accel pedal position track1 sensor Low fault - (P0122)
E000091-11	P2135	Accel pedal position sensor plausibility fault (Not synchronism between track1 and track2) - (P2135)
E000091-12	P2136	Hand pedal position sensor plausibility fault (Not synchronism between track1 and track2) - (P2136)
E000091-15	P0121	Hand pedal position track1 sensor High fault - (P0121)
E000091-17	P0124	Hand pedal position track1 sensor Low fault - (P0124)
E000091-19	U0606	Timeout Error of CAN-Receive-Frame EEC2 (Pedal) - (U0606)
E000097-03	P2267	Water In Fuel Sensor signal range high fault - (P2267)
E000097-04	P2266	Water In Fuel Sensor signal range low fault - (P2266)
E000097-14	P2269	Water in fuel detected - Warning step - (P2269)
E000097-22	P2264	Water in fuel detection internal fault - (P2264)
E000097-23	P2265	Water in fuel detected - Torque de-rate step (After 20min) - (P2265)
E000098-02	P250B	Oil level out of range error of oil combination(Level and temperature) sensor - (P250B)
E000098-03	P250D	Oil combination (Level and temperature) signal output short circuit to battery error - (P250D)
E000098-04	P250C	Oil combination (Level and temperature) signal output short circuit to ground error - (P250C)

Gauge Panel Fault Code	P Code	Fault Code Description
E000098-05	P250A	Oil combination (Level and temperature) sensor itself open or short circuit error - (P250A)
E000098-18	P250F	Oil level sensor SRC error of oil combination(Level and temperature) sensor - (P250F)
E000098-22	P350D	Oil combination (Level and temperature) sensor timeout fault - (P350D)
E000098-23	P350E	Oil combination (Level and temperature) sensor itself Voltage out of range error - (P350E)
E000098-24	P350F	Engine oil level is low (Low step2) - (P350F)
E000100-01	P1522	Engine Oil Pressure Too Low Fault - (P1522)
E000100-03	P0523	Engine Oil Pressure Sensor High Fault - (P0523)
E000100-04	P0522	Engine Oil Pressure Sensor Low Fault - (P0522)
E000102-03	P0108	Intake Manifold Pressure Sensor High Fault - (P0108)
E000102-04	P0107	Intake Manifold Pressure Sensor Low Fault - (P0107)
E000105-03	P00AD	Intake manifold temperature sensor High fault - (P00AD)
E000105-04	P00AC	Intake manifold temperature sensor Low fault - (P2454)
E000105-16	P10AD	Intake manifold temperature High fault - (P10AD)
E000108-03	P2229	Atmospheric Pressure Sensor High Fault - (P2229)
E000108-04	P2228	Atmospheric Pressure Sensor Low Fault - (P02E8)
E000110-00	P1118	Coolant high temperature Fault - (P1118)
E000110-03	P0118	Coolant Temperature Sensor High Fault - (P0118)
E000110-04	P0117	Coolant Temperature Sensor Low Fault - (P0117)
E000110-10	P011E	Coolant Temperature Plausibility Fault - (P011E)
E000132-01	P00BC	Intake manifold pressure low plausibility fault (Compressor out pressure too low) - (P00BC)
E000132-03	P0103	Signal range check high error for raw value in Air mass flow sensor - (P0103)
E000132-04	P0102	Signal range check low error for raw value in Air mass flow sensor - (P0102)
E000132-05	P0101	Battery voltage error of Air mass flow sensor - (P0101)
E000132-19	P0100	Signal error of Air mass flow sensor - (P0100)
E000132-21	P00BE	Sensitivity drift error low for Air mass flow sensor - (P00BE)
E000157-10	P0087	Fuel Leakage is detected based on fuel quantity balance - (P0087)
E000157-11	P0002	Maximum positive deviation of rail pressure exceeded - (P0002)
E000157-13	P193A	Rail pressure jittering activation for injector deposit removal - (P193A)
E000157-14	P193B	Rail pressure jittering activation maximum time reached - (P193B)
E000157-26	P190C	Minimum rail pressure exceeded - (P190C)
E000157-27	P190B	Maximum rail pressure exceeded - (P190B)
E000157-28	P1934	Pressure relief valve(PRV) failure - (P1934)
E000171-00	P1073	Environment Temperature Too High - (P1073)
E000171-03	P0073	Environment Temperature Sensor Signal High - (P0073)
E000171-04	P0072	Environment Temperature Sensor Signal Low - (P01C2)
E000172-00	P107D	Inlet air temperature High fault - (P107D)
E000172-03	P007D	Inlet air temperature sensor High fault - (P007D)

<b>Gauge Panel Fault Code</b>	<b>P Code</b>	<b>Fault Code Description</b>
E000172-04	P007C	Inlet air temperature sensor Low fault - (P007C)
E000173-01	P0421	DOC Exothermal Efficiency Fault - (P0421)
E000174-00	P1183	Fuel temperature high fault - (P1183)
E000174-03	P0183	Fuel Temperature Sensor High Fault - (P0183)
E000174-04	P0182	Fuel Temperature Sensor Low Fault - (P0182)
E000175-00	P1198	Oil temperature too high fault - (P1198)
E000175-01	P1197	Oil temperature too low fault - (P1197)
E000175-11	P0196	Oil combination (Level and temperature) sensor itself Oil temperature out of range error - (P0196)
E000177-15	P273F	Transmission oil temperature high fault (CAN) - (P273F)
E000177-16	P274F	Transmission oil temperature high fault (H/W Switch) - (P274F)
E000190-00	P0219	Engine over speed detection fault - (P0219)
E000444-00	P1563	Battery Voltage High fault (Warning) - (P1563)
E000444-01	P1562	Battery Voltage Low fault (Warning) - (P1562)
E000444-02	P1565	Powerstage diagnosis could be disabled due to low Battery voltage - (P1565)
E000444-03	P0563	Battery Voltage Signal Range Max fault - (P0563)
E000444-04	P0562	Battery Voltage Signal Range Min fault - (P0562)
E000444-12	P1564	Powerstage diagnosis disabled due to high Battery voltage - (P1564)
E000626-12	P0512	Starter switch stuck fault (Cranking request is too long.) - (P0512)
E000636-02	P0372	Crank Signal disturbed fault - (P0372)
E000636-08	P0374	Cranks No signal error - (P0374)
E000637-02	P0344	Cam Signal disturbed fault - (P0344)
E000637-08	P0342	Cam Signal Lost fault - (P0342)
E000637-30	P0340	Cam Signal Drift Fault - (P0340)
E000639-02	U0029	CAN communication error - (U0029)
E000639-19	U0028	CAN bus off error - (U0028)
E000651-02	P268C	Injector Code(IQA) Program Missing Fault (Cylinder#1) - (P268C)
E000651-04	P02EE	Injector Short circuit Fault (Cylinder #1) - (P02EE)
E000651-05	P0201	Injector Open circuit Fault (Cylinder #1) - (P0201)
E000651-22	P32EE	Injector High Low side Short circuit Fault (Cylinder #1) - (P32EE)
E000652-02	P268D	Injector Code(IQA) Program Missing Fault (Cylinder#2) - (P268D)
E000652-04	P02EF	Injector Short circuit Fault (Cylinder #2) - (P02EF)
E000652-05	P0202	Injector Open circuit Fault (Cylinder #2) - (P0202)
E000652-22	P32EF	Short circuit between high-side and low-side of the power stage (high-side non plausible error) for cylinder #2 - (P32EF)
E000653-02	P268E	Injector Code(IQA) Program Missing Fault (Cylinder#3) - (P268E)
E000653-04	P02F0	Injector Short circuit Fault (Cylinder #3) - (P02F0)
E000653-05	P0203	Injector Open circuit Fault (Cylinder #3) - (P0203)
E000653-22	P32F0	Injector High Low side Short circuit Fault (Cylinder #3) - (P32F0)
E000654-02	P268F	Injector Code(IQA) Program Missing Fault (Cylinder#4) - (P268F)
E000654-04	P02F1	Injector Short circuit Fault (Cylinder #4) - (P02F1)

<b>Gauge Panel Fault Code</b>	<b>P Code</b>	<b>Fault Code Description</b>
E000654-05	P0204	Injector Open circuit Fault (Cylinder #4) - (P0204)
E000654-22	P32F1	Short circuit between high-side and low-side of the power stage (high-side non plausible error) for cylinder #4 - (P32F1)
E000676-03	P0384	Glow plug Relay driver Short circuit to Battery Fault - (P0384)
E000676-04	P0383	Glow plug Relay driver Short circuit to Ground Fault - (P0383)
E000676-05	P0380	Glow plug Relay driver Open circuit Fault - (P0380)
E000729-07	P0640	Glowplug relay plausibility fault (Not operation) - (P0640)
E000970-12	U1003	Engine shut off request through CAN (EBC1) - (U1003)
E000970-22	P0215	Engine shut off request through hardwire - (P0215)
E000975-03	P028E	PWM FAN Output short to battery circuit fault - (P028E)
E000975-04	P028D	PWM FAN Output short to ground circuit fault - (P028D)
E000975-05	P028A	PWM FAN Output open circuit fault - (P028A)
E000987-03	P1931	CE(Check engine) Lamp Short to Battery - (P1931)
E000987-04	P192F	CE(Check engine) Lamp Short to Ground - (P192F)
E000987-05	P192E	CE(Check engine) Lamp Open circuit - (P192E)
E001076-03	P0004	Fuel Metering unit plausibility error in overrun mode - (P0004)
E001076-04	P0003	Fuel Metering unit plausibility error in idle mode - (P0003)
E001076-16	P0254	Maximum negative rail pressure deviation with metering unit on lower limit is exceeded - (P0254)
E001076-20	P0252	Rail pressure too low for injection - (P0252)
E001081-03	P2381	Glow plug Lamp Short to Battery - (P2381)
E001081-04	P1904	Glow plug Lamp Short to Ground - (P1904)
E001081-05	P0381	Glow plug Lamp Open circuit - (P0381)
E001207-00	P0669	ECU temperature High fault - (P0669)
E001207-03	P06AE	ECU temperature sensor High fault (Short circuit to battery) - (P06AE)
E001207-04	P06AD	ECU temperature sensor Low fault (Short circuit to ground) - (P06AD)
E001382-00	P018D	Fuel filter pressure high fault - (P018D)
E001382-01	P018C	Fuel filter pressure low fault - (P018C)
E001382-03	P01C6	Fuel filter pressure sensor signal high fault - (P01C6)
E001382-04	P01C2	Fuel filter pressure sensor signal low fault - (P0642)
E001382-07	P01C4	Fuel Filter Pressure low detection 1 - Warning - (P01C4)
E001382-13	P01C5	Fuel Filter Pressure low detection 2 - Torque reduction - (P01C5)
E001485-07	P0685	ECU Main relay Stuck fault - (P0685)
E001485-11	P068A	ECU Main relay Early opening fault - (P068A)
E001568-03	P2547	Multi-torque switch signal too high fault - (P2547)
E001568-04	P2546	Multi-torque switch signal too low fault - (P2546)
E001612-03	P062D	Injector bank 1st Short circuit fault - (P062D)
E001612-12	P062E	Injector bank 2nd Short circuit fault - (P062E)
E001639-03	P0528	Fan speed too high fault - (P0528)
E001639-04	P0529	Fan speed too low fault - (P0529)
E001639-11	P0527	Fan speed signal long period fault path - (P0527)

Gauge Panel Fault Code	P Code	Fault Code Description
E001761-19	P1230	DEF Tank Level Signal error - (P1230)
E001867-01	P2505	ECU over temperature for SCR Monitoring - (P2505)
E001867-03	P2508	"ABE active" report due to overvoltage detection - (P2508)
E001867-04	P2507	"ABE active" report due to undervoltage detection - (P2507)
E001867-11	P2511	"WDA/ABE active" report due to unknown reason - (P2511)
E001867-19	P2509	"WDA active" report due to errors in query-response communication - (P2509)
E001867-22	P2506	ECU Software Reset 0 fault - (P2506)
E001867-23	P3506	ECU Software Reset 1 fault - (P3506)
E001867-24	P1905	ECU Software Reset 2 fault - (P1905)
E002789-00	P1546	Turbine inlet temperature High fault - (P1546)
E002789-03	P0546	Turbine inlet temperature sensor High fault - (P0546)
E002789-04	P0545	Turbine inlet temperature sensor Low fault - (P2228)
E002789-11	P0544	Turbine inlet temperature Plausibility Fault - (P0544)
E002791-03	P2145	EGR H-Bridge Driver Short circuit to battery - (P2145)
E002791-04	P2144	EGR H-Bridge Driver Short circuit to ground - (P2144)
E002791-05	P2143	EGR H-Bridge Driver Open Circuit Fault - (P2143)
E003031-14	P205E	DEF Tank temperature overheated - (P205E)
E003031-16	P1045	DEF Tank Temperature sensor High plausibility fault - (P1045)
E003031-18	P1044	DEF Tank Temperature sensor Low plausibility fault - (P1044)
E003216-03	P2395	NOx sensor signal high fault (Upstream NOx sensor) - (P2395)
E003216-04	P2397	NOx sensor signal low fault (Upstream NOx sensor) - (P2397)
E003216-18	P225D	NOx sensor 1 (Upstream) concentration Low plausibility fault - (P225D)
E003217-03	P23A7	Linear Lambda signal high fault (Upstream NOx sensor) - (P23A7)
E003219-07	U030D	NOx sensor heating error (Upstream NOx sensor) - (U030D)
E003224-05	P2203	NOx sensor Open circuit fault (Upstream NOx sensor) - (P2203)
E003224-06	P2202	NOx sensor Short circuit fault (Upstream NOx sensor) - (P2202)
E003226-03	P2396	NOx sensor signal high fault (Downstream NOx sensor) - (P2396)
E003226-04	P2398	NOx sensor signal low fault (Downstream NOx sensor) - (P2398)
E003227-03	P23A8	Linear Lambda signal high fault (Downstream NOx sensor) - (P23A8)
E003229-07	U030E	NOx sensor heating error (Downstream NOx sensor) - (U030E)
E003234-05	P2216	NOx sensor Open circuit fault (Downstream NOx sensor) - (P2216)
E003234-06	P2215	NOx sensor Short circuit fault (Downstream NOx sensor) - (P2215)
E003236-00	P049B	EGR rate slow response positive error - (P049B)
E003236-16	P0408	Maximum EGR rate governor deviation - (P0408)
E003242-00	P1033	DPF(SCRf) inlet temperature High fault - (P1033)
E003242-03	P2033	DPF(SCRf) inlet temperature sensor High fault - (P2033)
E003242-04	P2032	DPF(SCRf) inlet temperature sensor Low fault - (P2032)
E003242-11	P2034	DPF(SCRf) inlet temperature Plausibility Fault - (P2034)
E003242-20	P2035	DPF(SCRf) inlet temperature Drift fault - (P2035)

Gauge Panel Fault Code	P Code	Fault Code Description
E003251-03	P2455	DPF differential pressure sensor High fault - (P2455)
E003251-04	P2454	DPF differential pressure sensor Low fault - (P2454)
E003251-13	P3052	DPF differential pressure drift fault - (P3052)
E003251-18	P1454	DPF differential pressure too low fault - (P1454)
E003360-14	P263D	DEF pressure line heater error (Perform afterrun) - (P263D)
E003361-03	P2047	DEF dosing valve actuator Short circuit to battery Fault - (P2047)
E003361-04	P2048	DEF dosing valve actuator Short circuit to ground Fault - (P2048)
E003361-05	P2049	DEF dosing valve actuator Open Circuit Fault - (P2049)
E003361-13	P202E	DEF dosing valve actuator Over temperature Fault - (P202E)
E003361-14	P2C11	Urea dosing valve plausibility fault - (P2C11)
E003361-22	P2050	DEF dosing valve actuator HS(High side) Short circuit to battery Fault - (P2050)
E003361-23	P2051	DEF dosing valve actuator HS(High side) Short circuit to ground Fault - (P2051)
E003361-27	P208E	DEF Dosing valve is blocked - (P208E)
E003363-03	P20B4	DEF Tank heating coolant valve output Short circuit to battery Fault - (P20B4)
E003363-04	P20B3	DEF Tank heating coolant valve output Short circuit to ground Fault - (P20B3)
E003363-05	P20B1	DEF Tank heating coolant valve output Open circuit Fault - (P20B1)
E003363-07	P30B1	DEF Tank heating coolant valve output Over temperature Fault - (P30B1)
E003509-03	P0659	ECU Sensor supply1 Over voltage fault - (P0659)
E003509-04	P0658	ECU Sensor supply1 Under voltage fault - (P0658)
E003509-05	P1657	ECU Sensor supply1 voltage fault - (P1657)
E003509-06	P0657	ECU Sensor supply1 Short circuit to ground - (P0657)
E003509-11	P0641	ECU Sensor supply Overvoltage monitoring error - (P0641)
E003510-03	P2671	ECU Sensor supply2 Over voltage fault - (P2671)
E003510-04	P2670	ECU Sensor supply2 Under voltage fault - (P2670)
E003510-05	P1669	ECU Sensor supply2 voltage fault - (P1669)
E003510-06	P2669	ECU Sensor supply2 Short circuit to ground - (P2669)
E003510-11	P0642	ECU Sensor supply Undervoltage monitoring error - (P0642)
E003511-03	P2686	ECU Sensor supply3 Over voltage fault - (P2686)
E003511-04	P2685	ECU Sensor supply3 Under voltage fault - (P2685)
E003511-05	P1684	ECU Sensor supply3 voltage fault - (P1684)
E003511-06	P2684	ECU Sensor supply3 Short circuit to ground - (P2684)
E003516-00	P106D	DEF Quality Too High fault - (P106D)
E003516-01	P106C	DEF Quality Too Low fault - (P106C)
E003516-12	P106E	DEF Quality failure status too long fault (Tampering) - (P106E)
E003517-18	P203F	DEF Tank level is empty - (P203F)
E003520-03	U1028	DEF Quality Sensor Open circuit - (U1028)
E003520-04	U1030	DEF Quality Sensor Short circuit - (U1030)

Gauge Panel Fault Code	P Code	Fault Code Description
E003532-03	P203A	DEF Level Sensor Open circuit - (P203A)
E003532-04	P2041	DEF Level Sensor Short circuit - (P2041)
E003695-03	P25BC	DPF regeneration inhibit switch Short to Battery fault (Hardwire) - (P25BC)
E003696-03	P25BB	DPF regeneration enable switch Short to Battery fault (Hardwire) - (P25BB)
E003696-11	P25BA	DPF regeneration inhibit & enable switch plausibility fault (Hardwire) - (P25BA)
E003697-03	P2611	DPF lamp 1 (DPF regeneration switch enable lamp) Short to Battery - (P2611)
E003697-04	P260F	DPF lamp 1 (DPF regeneration switch enable lamp) Short to Ground - (P260F)
E003697-05	P260E	DPF lamp 1 (DPF regeneration switch enable lamp) Open circuit - (P260E)
E003715-14	P246B	DPF regeneration failure (DPF regeneration is not performed well during machine operation mode) - (P246B)
E003720-16	P242F	DPF Ash loading High fault (Ash cleaning is needed) - (P242F)
E004082-03	P025D	Fuel metering unit Short circuit to Battery fault - (P025D)
E004082-04	P025C	Fuel metering unit Short circuit to Ground fault - (P025C)
E004082-05	P025A	Fuel metering unit Open circuit fault - (P025A)
E004082-07	P025B	Fuel metering unit Over temperature fault - (P025B)
E004335-00	P1450	DEF Overpressure error at METERINGCONTROL (DEF pump pressure is too high) - (P1450)
E004335-01	P1451	DEF Underpressure error at METERINGCONTROL (DEF pump pressure is too low) - (P1451)
E004335-02	P1457	DEF pressure build up error at PRESSUREBUILDUP (DEF pump pressure is too low) - (P1457)
E004335-07	P202D	DEF Leakage detection at METERINGCONTROL - (P202D)
E004335-12	P1452	DEF Overpressure error regardless of the state - (P1452)
E004335-15	P1459	DEF Pressure reduction error at PRESSUREREDUCTION (Detected an insufficient pressure drop) - (P1459)
E004335-16	P1460	DEF underpressure error at AFTERRUN_PRESSURECOMPENSATION - (P1460)
E004344-02	P1893	DEF backflow Line plausibility error at DETECTIONMODE (Does not detect a pressure drop) - (P1893)
E004354-05	P221D	DEF Pressure line heater circuit Open circuit Fault - (P221D)
E004354-06	P221C	DEF Pressure line heater circuit Open circuit or Short circuit to ground Fault - (P221C)
E004355-05	P221F	DEF Backflow line heater circuit Open circuit Fault - (P221F)
E004355-06	P221E	DEF Backflow line heater circuit Open circuit or Short circuit to ground Fault - (P221E)
E004356-05	P215F	DEF Suction line heater circuit Open circuit Fault - (P215F)
E004356-06	P215E	DEF Suction line heater circuit Open circuit or Short circuit to ground Fault - (P215E)
E004364-14	P20EE	SCR Efficiency Too low fault - (P20EE)
E004365-03	P2043	DEF Temperature Sensor Open circuit - (P2043)

<b>Gauge Panel Fault Code</b>	<b>P Code</b>	<b>Fault Code Description</b>
E004365-04	P2046	DEF Temperature Sensor Short circuit - (P2046)
E004365-14	P1227	DEF Tank temperature plausibility fault (Insufficient temperature increment) - (P1227)
E004374-03	P208D	DEF Supply Pump Motor Signal output Short circuit to battery Fault - (P208D)
E004374-04	P208C	DEF Supply Pump Motor Signal output Short circuit to ground Fault - (P208C)
E004374-05	P208A	DEF Supply Pump Motor Signal output Open circuit Fault - (P208A)
E004374-07	P208B	DEF Supply Pump Motor Signal output Over temperature Fault - (P208B)
E004374-08	P108A	DEF Supply Pump Motor Speed Deviation Fault - (P108A)
E004374-09	P108B	DEF Supply Pump Motor Speed Deviation Permanent Fault - (P108B)
E004374-12	P108C	DEF Supply Pump Motor No activation Fault - (P108C)
E004781-15	P24A3	DPF Soot mass too high status (> 120%) - (P24A3)
E004781-16	P2463	DPF Soot mass high status (> 110%) - (P2463)
E005067-03	P0593	PTO (Idle up) Lamp Short to Battery - (P0593)
E005067-04	P0592	PTO (Idle up) Lamp Short to Ground - (P0592)
E005067-05	P0591	PTO (Idle up) Lamp Open circuit - (P0591)
E005099-03	P055D	Oil Pressure Warning Lamp Short to Battery - (P055D)
E005099-04	P055C	Short circuit to ground error of oil pressure lamp - (P055C)
E005099-05	P055B	Oil Pressure Warning Lamp Open circuit - (P055B)
E005313-03	P0193	Rail pressure sensor High fault - (P0193)
E005313-04	P0192	Rail pressure sensor Low fault - (P0182)
E005419-03	P02E3	Throttle valve H-Bridge Driver Short circuit to battery - (P02E3)
E005419-04	P02E2	Throttle valve H-Bridge Driver Short circuit to ground - (P02E2)
E005419-05	P02E0	Throttle valve H-Bridge Driver Open Circuit Fault - (P02E0)
E005435-10	P1453	DEF pressure stabilization error at DETECTIONMODE (DEF pump pressure is not stable) - (P1453)
E005435-12	P204A	DEF pressure check error at DETECTIONMODE (Detected an insufficient pressure drop) - (P204A)
E005436-03	P20A3	DEF Reverting valve output Short circuit to battery Fault - (P20A3)
E005436-04	P20A2	DEF Reverting valve output Short circuit to ground Fault - (P20A2)
E005436-05	P20A0	DEF Reverting valve output Open circuit Fault - (P20A0)
E005436-07	P20A1	DEF Reverting valve output Over temperature Fault - (P20A1)
E005436-11	P20A5	DEF Reverting valve Pressure drop plausibility fault - (P20A5)
E005436-14	P1461	DEF Reverting valve is blocked (Detected an insufficient pressure drop) - (P1461)
E005491-03	P20C0	DEF Pressure line heater relay output Short circuit to battery Fault - (P20C0)
E005491-04	P20BF	DEF Pressure line heater relay output Short circuit to ground Fault - (P20BF)
E005491-05	P20BD	DEF Pressure line heater relay output Open circuit Fault - (P20BD)
E005491-07	P30BD	DEF Pressure line heater relay output Over temperature Fault - (P30BD)
E005491-12	P20BE	DEF Pressure line heater feedback plausibility Fault - (P20BE)



<b>Gauge Panel Fault Code</b>	<b>P Code</b>	<b>Fault Code Description</b>
E005571-22	P009B	Common rail pressure relief valve reached maximum allowed opening count - (P009B)
E005571-23	P009C	Common rail pressure relief valve Forced to open status (Pressure increase) - (P009C)
E005571-24	P009D	Common rail pressure relief valve Forced to open status (Pressure shock) - (P009D)
E005571-25	P000F	Common rail pressure relief valve is open - (P000F)
E005571-27	P009F	Averaged rail pressure is outside the expected tolerance range - (P009F)
E005571-28	P018F	Common rail pressure relief valve reached maximum allowed open time - (P018F)
E005629-14	P246C	DPF differential pressure too high fault - (P246C)
E005706-05	P214F	DEF Supply module heater circuit Open circuit Fault - (P214F)
E005706-06	P21DD	DEF Supply module heater circuit Open circuit or Short circuit to ground Fault - (P21DD)
E005706-12	P23B3	DEF Supply module heater temperature plausibility fault (Insufficient temperature increment) - (P23B3)
E005706-14	P23B4	DEF Supply module heater temperature plausibility fault at cold start (Insufficient temperature increment) - (P23B4)
E005706-22	P23B2	DEF Supply module heater plausibility fault (Insufficient temperature increment) - (P23B2)
E005746-03	P21C4	DEF Main heater relay output Short circuit to battery Fault - (P21C4)
E005746-04	P21C3	DEF Main heater relay output Short circuit to ground Fault - (P21C3)
E005746-05	P21C2	DEF Main heater relay output Open circuit Fault - (P21C2)
E005746-06	P05ED	DEF heater line circuit Short circuit to battery Fault - (P05ED)
E005746-07	P31C5	DEF Main heater relay output Over temperature Fault - (P31C5)
E005965-03	P21C9	SCR system Main relay short circuit to battery - (P21C9)
E005965-04	P21C8	SCR system Main relay short circuit to ground - (P21C8)
E005965-05	P21C7	SCR system Main relay open circuit - (P21C7)
E006323-03	P2634	Electric fuel feed pump Output short to battery circuit fault - (P2634)
E006323-04	P2633	Electric fuel feed pump Output short to ground circuit fault - (P2633)
E006323-05	P2632	Electric fuel feed pump Output open circuit fault - (P2632)
E006323-13	P2635	Electric fuel feed pump performance fault - (P2635)
E006385-19	U1033	Timeout Error of CAN-Receive-Frame EOI (Engine Starter Motor Relay Control) - (U1033)
E006875-03	P204D	DEF Supply Pump pressure sensor High fault - (P204D)
E006875-04	P204C	DEF Supply Pump pressure sensor Low fault - (P204C)
E006875-16	P304D	DEF Supply Pump pressure sensor High plausibility fault - (P304D)
E006875-18	P304C	DEF Supply Pump pressure sensor Low plausibility fault - (P304C)
E006915-03	P3611	DPF lamp 2 (DPF Regeneration Active Lamp) Short to Battery - (P3611)
E006915-04	P360F	DPF lamp 2 (DPF Regeneration Active Lamp) Short to Ground - (P360F)
E006915-05	P360E	DPF lamp 2 (DPF Regeneration Active Lamp) Open circuit - (P360E)
E006916-03	P1908	DPF lamp 3 (DPF regeneration switch inhibit lamp) Short to Battery - (P1908)

Gauge Panel Fault Code	P Code	Fault Code Description
E006916-04	P1907	DPF lamp 3 (DPF regeneration switch inhibit lamp) Short to Ground - (P1907)
E006916-05	P1906	DPF lamp 3 (DPF regeneration switch inhibit lamp) Open circuit - (P1906)
E007069-03	P20C4	DEF Backflow line heater relay output Short circuit to battery Fault - (P20C4)
E007069-04	P20C3	DEF Backflow line heater relay output Short circuit to ground Fault - (P20C3)
E007069-05	P20C1	DEF Backflow line heater relay output Open circuit Fault - (P20C1)
E007069-07	P30C1	DEF Backflow line heater relay output Over temperature Fault - (P30C1)
E007069-12	P20C2	DEF Backflow line heater feedback plausibility Fault - (P20C2)
E007107-12	P23B5	DEF Supply module temperature plausibility fault (Insufficient temperature increment) - (P23B5)
E007107-14	P23B6	DEF Supply module temperature plausibility fault at cold start (Insufficient temperature increment) - (P23B6)
E007416-03	P20BC	DEF Supply module heater relay output Short circuit to battery Fault - (P20BC)
E007416-04	P20BB	DEF Supply module heater relay output Short circuit to ground Fault - (P20BB)
E007416-05	P20B9	DEF Supply module heater relay output Open circuit Fault - (P20B9)
E007416-07	P30B9	DEF Supply module heater relay output Over temperature Fault - (P30B9)
E007416-12	P20BA	DEF Supply module heater feedback plausibility Fault - (P20BA)
E007538-12	P06F0	DEF Supply module temperature duty cycle in failure range - (P06F0)
E007538-13	P06F1	Diagnostic Fault Check for Urea supply module duty cycle in the invalid range - (P06F1)
E007538-22	P20AC	DEF Supply module heater temperature duty cycle in failure range - (P20AC)
E007538-23	P20AD	DEF Supply module heater temperature duty cycle in invalid range - (P20AD)
E007538-24	P20B0	DEF Supply module temperature measurement non-availability fault - (P20B0)
E007538-25	P20FF	DEF Supply module time period outside specified range - (P20FF)
E007538-26	P056D	DEF Supply module PWM signal fault - (P056D)
E007540-03	P20C8	DEF Suction line heater relay output Short circuit to battery Fault - (P20C8)
E007540-04	P20C7	DEF Suction line heater relay output Short circuit to ground Fault - (P20C7)
E007540-05	P20C5	DEF Suction line heater relay output Open circuit Fault - (P20C5)
E007540-07	P30C5	DEF Suction line heater relay output Over temperature Fault - (P30C5)
E007540-12	P20C6	DEF Suction line heater feedback plausibility Fault - (P20C6)
E007748-03	P0617	Starter relay HS power stage output short circuit to battery - (P0617)
E007748-04	P0616	Starter relay HS power stage output short circuit to ground - (P0616)
E007748-05	P0615	Starter relay HS output open circuit - (P0615)
E007749-03	P26E6	Starter relay LS power stage output short circuit to battery - (P26E6)
E007749-04	P26E5	Starter relay LS power stage output short circuit to ground - (P26E5)
E007749-05	P26E4	Starter relay LS power stage output open circuit - (P26E4)
E008614-12	P213E	Injection cut off demand (ICO) for shut off coordinator - (P213E)
E055296-12	P062F	ECU EEPROM Read Error - (P062F)
E055552-12	P0630	ECU EEPROM Write Error - (P0630)

Gauge Panel Fault Code	P Code	Fault Code Description
E057344-19	U01B7	Timeout Error of CAN-Receive-Frame CM1 (Status of regeneration initiate and inhibit switches) - (U01B7)
E061441-19	U01B9	Timeout Error of CAN-Receive-Frame EBC1 (Engine shut off request) - (U01B9)
E061454-19	U029D	Timeout Error of CAN-Receive-Frame AT1IG1 (NOx Upstream Concentration) - (U029D)
E061455-19	U029E	Timeout Error of CAN-Receive-Frame AT1O1 (NOx Downstream Concentration) - (U029E)
E064923-19	U02A2	Timeout Error of CAN-Receive-Frame A1DEFI (DEF Tank) - (U02A2)
E065110-19	U0619	Timeout Error of CAN-Receive-Frame AT1T1I (Urea Level, Temperature over CAN) - (U0619)
E065164-19	U1001	Timeout Error of CAN-Receive-Frame AAI (Hydraulic Oil Temperature) - (U1001)
E065241-19	U1031	Timeout Error of CAN-Receive-Frame AUXIO1 - (U1031)
E065265-19	U1032	Timeout Error of CAN-Receive-Frame RxCCVS (PTO / Idle up) - (U1032)
E065272-19	P0218	Timeout Error of CAN-Receive-Frame TRF1 (Transmission oil temperature) - (P0218)
E065320-19	U0632	Timeout Error of CAN-Receive-Frame FanCtl (FAN Control) - (U0632)
E065320-31	U1039	DFC for error of FAN control (Fan Control) - (U1039)
E065400-19	U0608	Timeout Error of CAN-Receive-Frame RxSMVCU (Pedal & Engine speed demand from VCU) - (U0608)
E065400-22	U013C	Message Check Sum Error of CAN Receive Frame SMVCU (Pedal & Engine speed demand from VCU) - (U013C)
E065400-23	U043D	Message Counter Error of CAN Receive Frame SMVCU (Pedal & Engine speed demand from VCU) - (U043D)
E065401-19	U010F	Timeout Error of CAN-Receive-Frame DPM1 (Air Conditioning Switch Status / Oil life reset) - (U010F)
E065402-19	U01B8	Timeout Error of CAN-Receive-Frame DPM9 (Multiple torque Map select switch) - (U01B8)
E104332-09	P2383	NOx sensor Mounting Error (Upstream NOx sensor) - (P2383)
E104385-09	P2384	NOx sensor Mounting Error (Downstream NOx sensor) - (P2384)
E520601-12	P160B	CY327(Power control chipset) SPI Communication Error - (P160B)
E520618-12	P060B	ECU ADC(Analog to Digital Converter) NTP(Null Load Test Pulse) Monitoring fault - (P060B)
E520641-12	P160F	ECU ROM Memory multiple error - (P160F)
E520642-12	P1610	ECU MM(Monitoring Module) Synchronization Loss fault during Shut-off path test - (P1610)
E520643-12	P101A	MoF(Monitoring of Function) Over Run error - (P101A)
E520696-12	P160C	ECU ADC(Analog to Digital Converter) Test error - (P160C)
E520697-12	P160D	ECU ADC(Analog to Digital Converter) Voltage ratio error - (P160D)
E520698-12	P060C	ECU query response-communication error - (P060C)
E520699-12	P160E	ECU SPI-communication error - (P160E)
E520700-12	P1611	ECU Shut-off path test error - (P1611)
E520701-12	P1612	ECU Wrong set response time error during shut off path test - (P1612)

Gauge Panel Fault Code	P Code	Fault Code Description
E520702-12	P1613	ECU Too many SPI errors during shut off path test - (P1613)
E520703-12	P1615	ECU WDA working error during Shut-off path test - (P1615)
E520704-12	P1616	ECU OS Timeout error during Shut-off path test - (P1616)
E520705-12	P1617	ECU Positive test failure error during Shut-off path test - (P1617)
E520706-12	P1618	ECU Shut-off path test timeout fault - (P1618)
E520707-03	P1619	ECU Overvoltage error during Shut-off path test - (P1619)
E520707-04	P1614	ECU Undervoltage error during Shut-off path test - (P1614)
E520723-12	P12E5	NCD Inducement Fault Level1 (Group1 - EGR Block) - (P12E5)
E520724-12	P12E6	NCD Inducement Fault Level2 (Group1 - EGR Block) - (P12E6)
E520725-12	P12E7	NCD Inducement Fault Level3 Final inducement (Group1 - EGR Block) - (P12E7)
E520726-12	P12E8	NCD Inducement Fault Warning (Group1 - EGR Block) - (P12E8)
E520727-12	P12E9	NCD Inducement Fault Level1 (Group2 - Dosing Interrupt) - (P12E9)
E520728-12	P12EA	NCD Inducement Fault Level2 (Group2 - Dosing Interrupt) - (P12EA)
E520729-12	P12EB	NCD Inducement Fault Level3 Final inducement (Group2 - Dosing Interrupt) - (P12EB)
E520730-12	P12EC	NCD Inducement Fault Warning (Group2 - Dosing Interrupt) - (P12EC)
E520736-12	P12F2	NCD inducement Fault Level1 (Group4 - DEF Quality) - (P12F2)
E520737-12	P12F3	NCD inducement Fault Level2 (Group4 - DEF Quality) - (P12F3)
E520738-12	P12F4	NCD inducement Fault Level3 Final inducement (Group4 - DEF Quality) - (P12F4)
E520739-12	P12F5	NCD inducement Fault Warning (Group4 - DEF Quality) - (P12F5)
E520740-12	P12F6	NCD inducement Fault Level1 (Group5 - Tampering) - (P12F6)
E520741-12	P12F7	NCD inducement Fault Level2 (Group5 - Tampering) - (P12F7)
E520742-12	P12F8	NCD inducement Fault Level3 Final inducement (Group5 - Tampering) - (P12F8)
E520743-12	P12F9	NCD inducement Fault Warning (Group5 - Tampering) - (P12F9)
E520790-12	P1303	NCD inducement Repeat offense Level1 - (P1303)
E520791-12	P1304	NCD inducement Repeat offense Level2 - (P1304)
E520792-12	P1305	NCD inducement Repeat offense Level3 Final inducement - (P1305)
E520797-12	P1013	DEF Supply Pump pressure sensor Low plausibility fault - (P1013)





# CEWCP HW100A Hydraulic Schematic

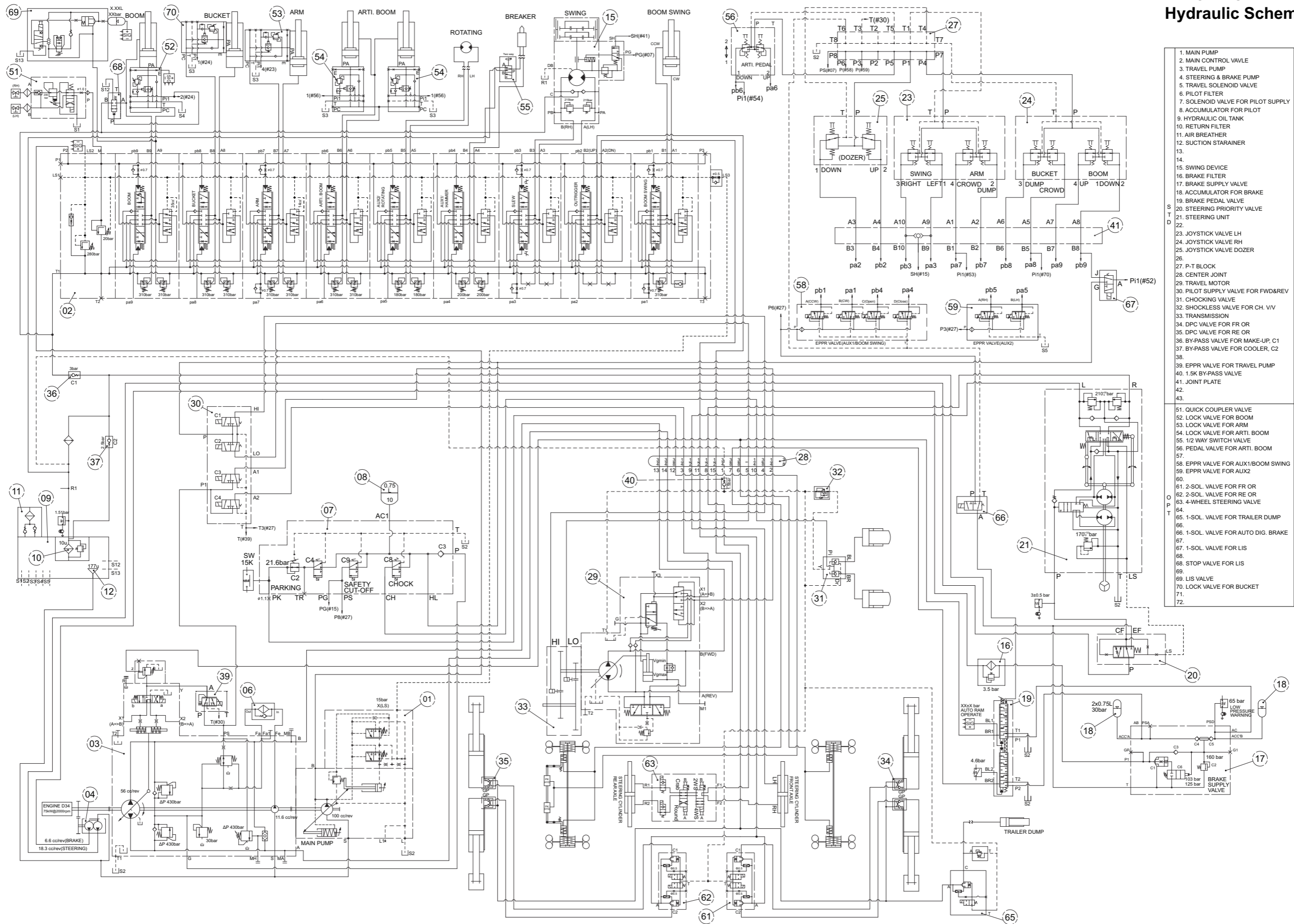

1. MAIN PUMP
2. MAIN CONTROL VALVE
3. TRAVEL PUMP
4. STEERING & BRAKE PUMP
5. TRAVEL SOLENOID VALVE
6. PILOT FILTER
7. SOLENOID VALVE FOR PILOT SUPPLY
8. ACCUMULATOR FOR PILOT
9. HYDRAULIC OIL TANK
10. RETURN FILTER
11. AIR BREATHER
12. SUCTION STRAINER
- 13.
- 14.
15. SWING DEVICE
16. BRAKE FILTER
17. BRAKE SUPPLY VALVE
18. ACCUMULATOR FOR BRAKE
19. BRAKE PEDAL VALVE
20. STEERING PRIORITY VALVE
21. STEERING UNIT
- 22.
23. JOYSTICK VALVE LH
24. JOYSTICK VALVE RH
25. JOYSTICK VALVE DOZER
- 26.
27. P-T BLOCK
28. CENTER JOINT
29. TRAVEL MOTOR
30. PILOT SUPPLY VALVE FOR FWD&REV
31. CHOCKING VALVE
32. SHOCKLESS VALVE FOR CH. V/V
33. TRANSMISSION
34. DPC VALVE FOR FR OR
35. DPC VALVE FOR RE OR
36. BY-PASS VALVE FOR MAKE-UP, C1
37. BY-PASS VALVE FOR COOLER, C2
- 38.
39. EPPR VALVE FOR TRAVEL PUMP
40. 1.5K BY-PASS VALVE
41. JOINT PLATE
- 42.
- 43.
51. QUICK COUPLER VALVE
52. LOCK VALVE FOR BOOM
53. LOCK VALVE FOR ARM
54. LOCK VALVE FOR ARTI. BOOM
55. 1/2 WAY SWITCH VALVE
56. PEDAL VALVE FOR ARTI. BOOM
- 57.
58. EPPR VALVE FOR AUX1/BOOM SWING
59. EPPR VALVE FOR AUX2
- 60.
61. 2-SOL. VALVE FOR FR OR
62. 2-SOL. VALVE FOR RE OR
63. 4-WHEEL STEERING VALVE
- 64.
65. 1-SOL. VALVE FOR TRAILER DUMP
- 66.
67. 1-SOL. VALVE FOR AUTO DIG. BRAKE
- 68.
69. 1-SOL. VALVE FOR LIS
70. STOP VALVE FOR LIS
71. LIS VALVE
72. LOCK VALVE FOR BUCKET





# CEWCP\_HW100A Electrical Schematic(1/2)

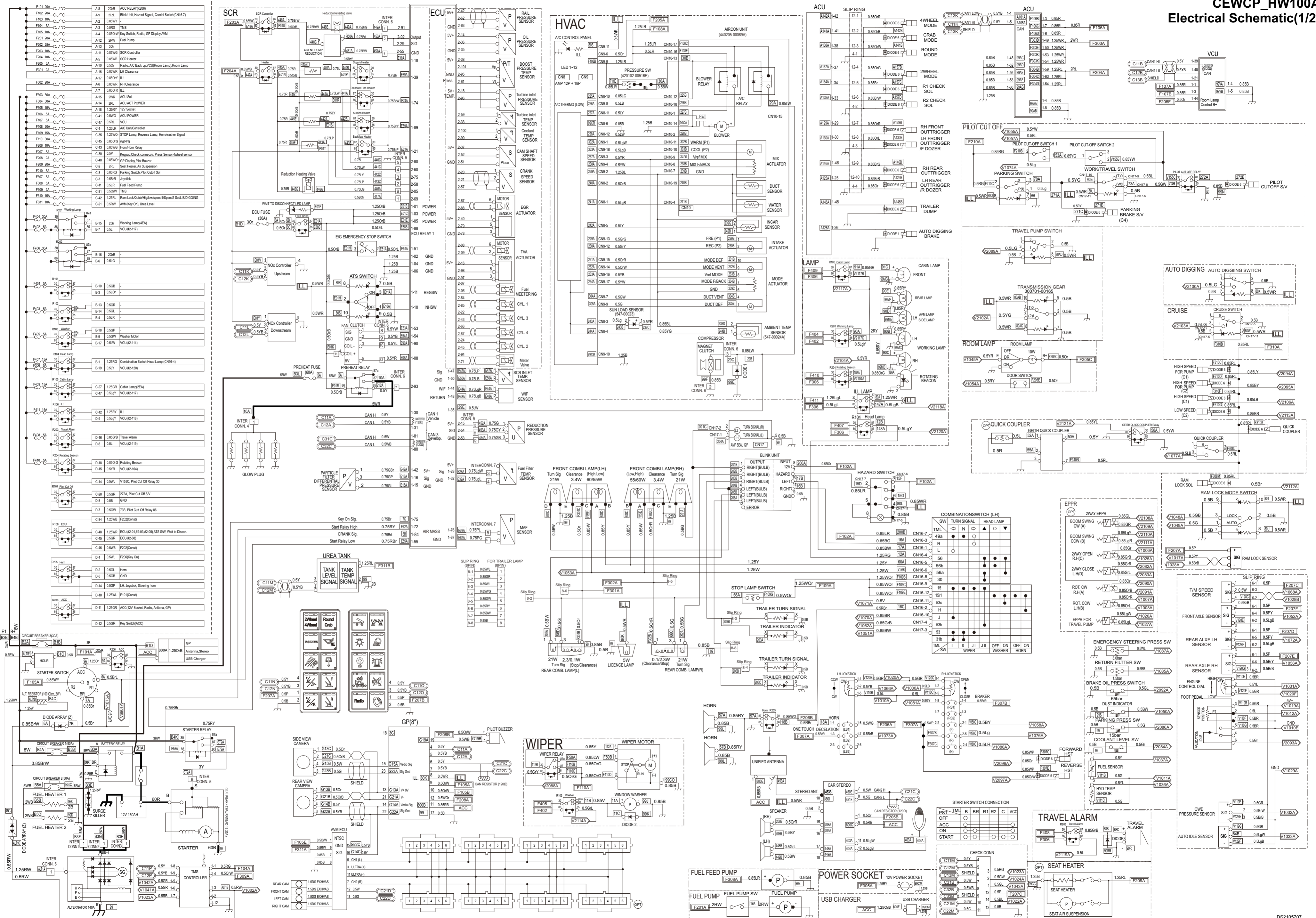

VCU

1-01	POWER
1-02	Analog Input / Alternator L
1-03	POWER
1-04	GND
1-05	GND
1-06	RH-Open (Zway) EPPR +
1-07	LH-CCW (Rotating) +
1-08	LH-CCW (Rotating) -
1-09	X
1-10	Engine Control dial 1
1-11	GND (Fuel Sensor / Hyd Temp)
1-12	Accel Pedal sensor(wheel)
1-13	-
1-14	-
1-15	-
1-16	-
1-17	Ram Lock Pressure Sensor
1-18	-
1-19	SV VCC
1-20	SV VCC
1-21	CAN Shield (GND)
1-22	Check connector 14 pin
1-23	RS-232 GND
1-24	RS-232 Rx1
1-25	RH-Open (Zway) EPPR -
1-26	EPPR VALVE FOR TRAVEL PUMP+
1-27	EPPR VALVE FOR TRAVEL PUMP-
1-28	TM Speed Sensor 3 (-)
1-29	Auto Idle press Sensor (-)
1-30	Thumb wheel (RH)
1-31	Engine Control dial 2 / Sig
1-32	GND Pressure Sensor / Sig
1-33	Auto Idle press Sensor / Sig
1-34	-
1-35	-
1-36	HYD. Oil Temp. Sensor
1-37	Fuel Sensor
1-38	-
1-39	CAN High
1-40	CAN Low
1-41	RS-232 Rx2
1-42	RS-232 Tx2
1-43	RS-232 Tx1
1-44	TV 2/1 2/2 2/3 2/4
1-45	Room Lamp Dimming
1-46	-
1-47	-
1-48	RAM Lock SW LOCK
1-49	RAM Lock SW AUTO
1-50	Air Cleaner Indicator
1-51	Wiper J1 SW
1-52	FRONT AXLE SENSOR SIG
1-53	High Beam (wheel)
1-54	Door Switch
1-55	Pilot Cutoff SW
1-56	REAR AXLE RH SENSOR SIG
1-57	Travel Mode(wheel)
1-58	Forward SW
1-59	-
1-60	-
1-61	-
1-62	Wiper J2 SW
1-63	-
1-64	-
1-65	-
1-66	-
1-67	Thumb wheel (LH)
1-68	TM Speed Sensor
1-69	STARTER C1 1 2
1-70	Wiper Continuous SW
1-71	Washer SW
1-72	REAR AXLE LH SENSOR SIG
1-73	On/Off deceleration switch/Quick Op SW
1-74	Parking switch(wheel)
1-75	Key-on (BR) Signal
1-76	Reverse SW
1-77	Quick Coupler Mode SW
1-78	-
1-79	-
1-80	Neutral
1-81	Breaker Operating SW / Quick Op SW

2-82	Zway Close L(H/B) +
2-83	Zway Close L(H/B) -
2-84	Circuit Breaker SW
2-85	Return Filter SW
2-86	Parking Brake Pressure SW
2-87	Emergency Steering Pressure SW
2-88	WIPER RELAY
2-89	PUMP TRAVEL 1/2
2-90	ROT.CW R.H(C) +
2-91	ROT.CW R.H(C) -
2-92	Brake Oil Pressure SW
2-93	Accel Pedal Switch(Idle validation sw)
2-94	1 1/2 CT Sol 4 1 2
2-95	2 1/2 CZ Sol 4 1 2
2-96	HST Forward Sol
2-97	HST Reverse Sol
2-98	-
2-99	-
2-100	Auto Digging SW
2-101	-
2-102	Trans mission 1/2
2-103	Cruise SW
2-104	Rotating Beacon Relay
2-105	-
2-106	High speed C1 sol 4 1 2
2-107	-
2-108	Boom Swing R +
2-109	Boom Swing R -
2-110	Boom Swing L +
2-111	Boom Swing L -
2-112	RAM Lock SV
2-113	Low Speed C2 Sol 4 1 2
2-114	Washer Relay
2-115	-
2-116	Back Up Lamp Relay
2-117	Cabin Lamp Relay/Working Lamp Relay
2-118	ILL Relay
2-119	Alarm Relay
2-120	Head Lamp Relay
2-121	Quick Coupler SV

ACU

1-01	CAN Low
1-02	CAN Shield
1-03	BAT+
1-04	GND
1-05	CAN High
1-06	KEY ON
1-07	BAT+
1-08	GND
1-09	-
1-10	-
1-11	-
1-12	-
1-13	-
1-14	-
1-15	-
1-16	-
1-17	-
1-18	-
1-19	-
1-20	-
1-21	GND
1-22	-
1-23	-
1-24	-
1-25	RL OUTTRIGGER SV
1-26	-
1-27	-
1-28	-
1-29	FR OUTTRIGGER SV
1-30	FL OUTTRIGGER SV
1-31	-
1-32	-

