

## GROUP 3 ATTACHMENT HOLDER(Quick coupler)

The attachment holder unit provides a structure on which an implement may be attached or removed from the loader. It is secured to the boom and bucket cylinders with pins, bolt and lock nuts. Hand levers and locking pin are used to secure an implement to the attachment holder assembly.

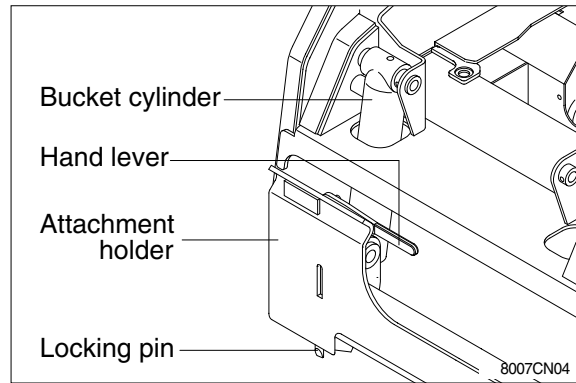

### 1. REMOVAL

- 1) Remove any implement from the attachment holder.
- 2) Raise the boom and place blocking under the rear of the attachment holder frame.
- 3) Lower the boom until the rear of the attachment holder frame is supported by the blocking.

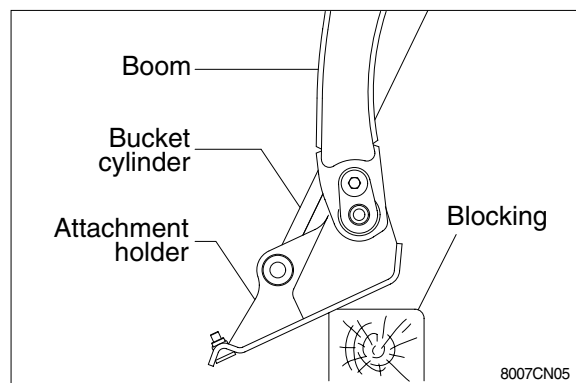

- 4) Tilt the attachment holder forward until the front of the frame rests on the ground.
- 5) Shut off the engine.
- 6) Cycle the control levers to relieve any hydraulic pressure in the system
- 7) Remove the bolt(1), lock nut and pin attaching the bucket cylinder to the attachment holder frame.
- 8) Remove the bolt(2), washer, spacer and pin attaching the boom to the attachment holder frame.

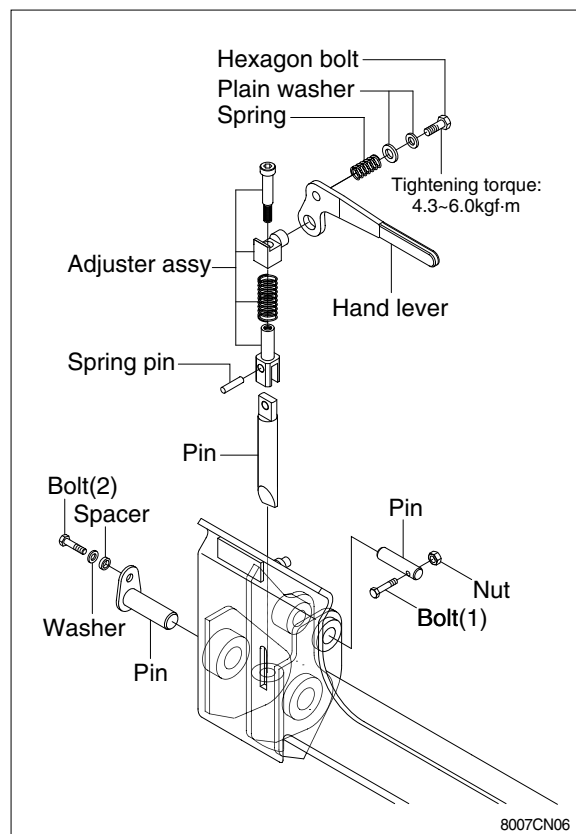

## 2. INSTALL

- 1) Position the attachment holder between the boom.
- 2) Put a floor jack under the attachment holder and raise it until the boom hinge and attachment holder bushings are aligned.
- 3) Install the boom hinge pin(1) and secure it with a bolt(2).
- 4) Install the bucket cylinder hinge pin(3) and secure it with a bolt(4) and lock nut(5).
- 5) Lubricate the hinge pins at the appropriate fittings.

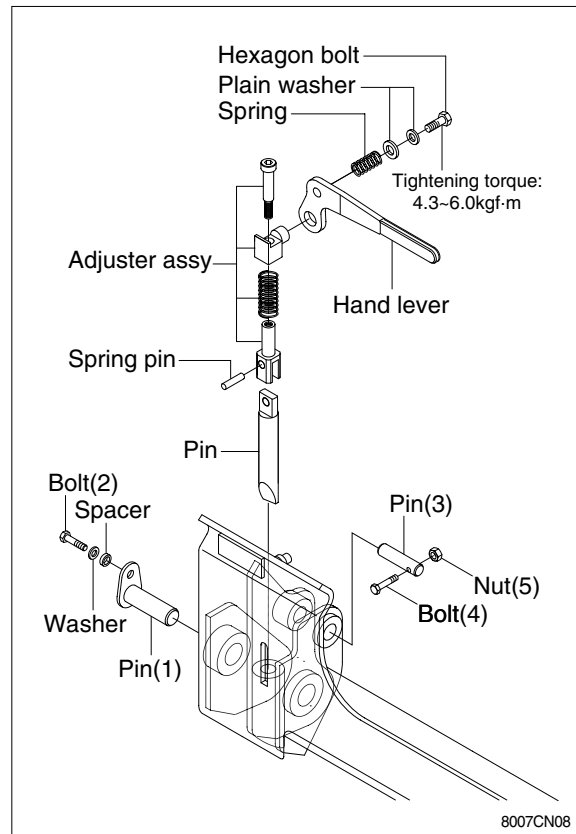

## 3. LOCKING PIN ADJUSTMENT

- 1) Raise the boom slightly and tilt the attachment holder forward just far enough so the hand levers can be pulled up.
- 2) Turn the engine off and exit the loader.
- 3) Fully raise both hand levers until the locking pins are retracted into the attachment holder(Unlock position).
- 4) Measure from the top of the attachment holder frame to the bottom of the locking pin.
  - ※ If the dimension is not 393mm, adjust to the locking pin as follows.
    - Adjust the bolt(B) until a 393mm dimension is achieved.
- 5) Repeat the procedure for the other locking pin assembly.

