

## GROUP 3 SELF LEVEL VALVE(OPTION)

### 1. STRUCTURE

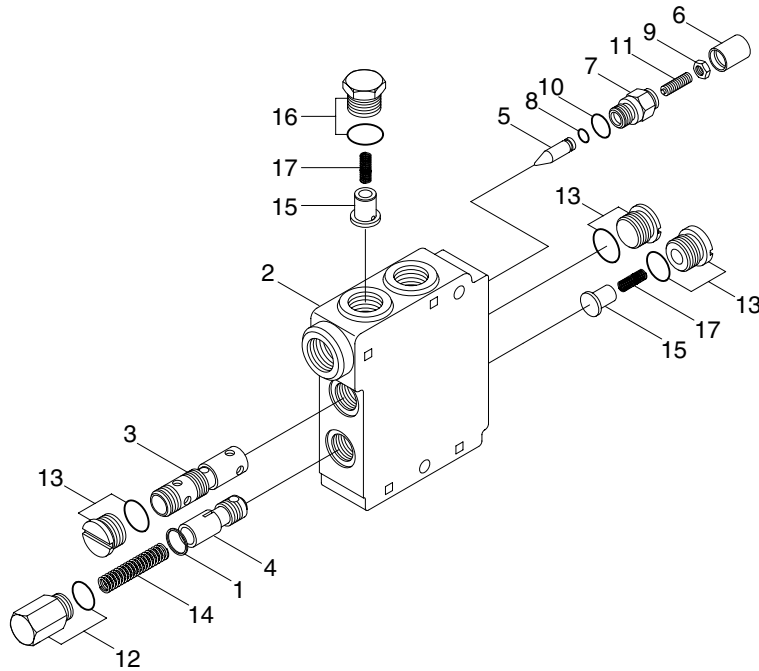

8007HT06

- |   |                |    |            |    |                    |
|---|----------------|----|------------|----|--------------------|
| 1 | Retaining ring | 7  | Adjust cap | 13 | Plug               |
| 2 | Body           | 8  | O-ring     | 14 | Spring             |
| 3 | Spool          | 9  | Jam nut    | 15 | Load check plunger |
| 4 | Spool          | 10 | O-ring     | 16 | Plug               |
| 5 | Pin            | 11 | Set screw  | 17 | Spring             |
| 6 | Cover          | 12 | Plug       |    |                    |

### 2. HYDRAULIC CIRCUIT

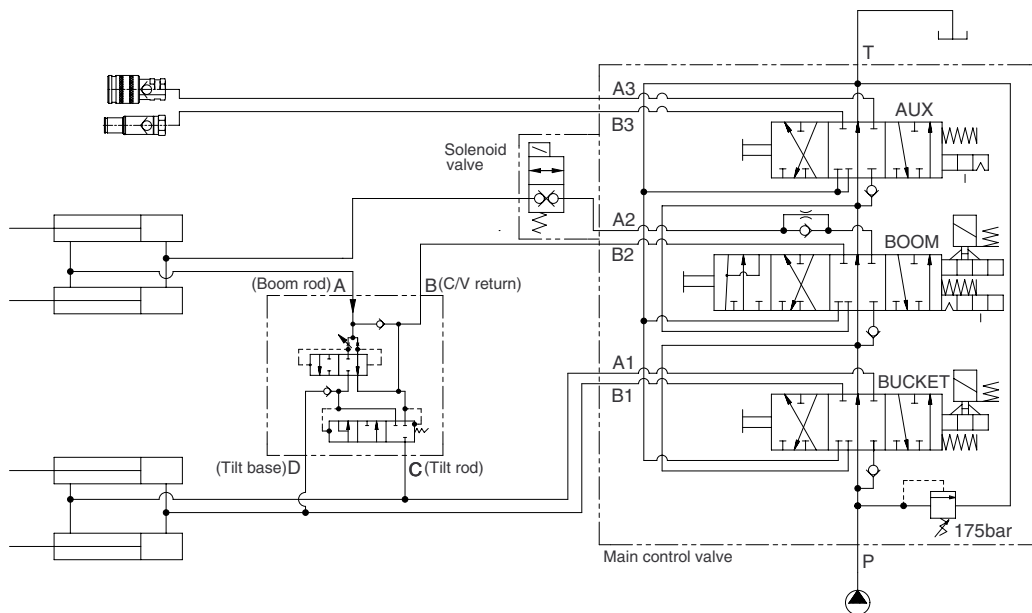

8007HT07

### 3. SELF LEVELING

With the bucket spool in **neutral** and the boom spool pulled **out**, flow from the control valve enters the head port of the boom cylinder. As the boom extends, flow from the rod port is directed to port A on the self level valve. Flow entering port A is able to pass through the adjustable orifice and fixed orifice in the flow divider spool. The proportion of the flow split is determined by size of the adjustable orifice.

The remainder of the flow passes through the fixed orifice, out port B back to the control valve and returns to tank. The flow that passes through the adjustable orifice flows out port D and is teed to the head port of the bucket cylinder.

The resistance on the movement of the bucket cylinder creates a pressure high enough to open the unloading spool in the self level valve. As the bucket cylinder extends the flow from the rod port of the bucket cylinder enters port C past the open unloading spool, around the flow divider spool and out port B back to the control valve and returns to tank. The purpose of the unloading spool is to prevent the bucket cylinder from dumping during the self level cycle.

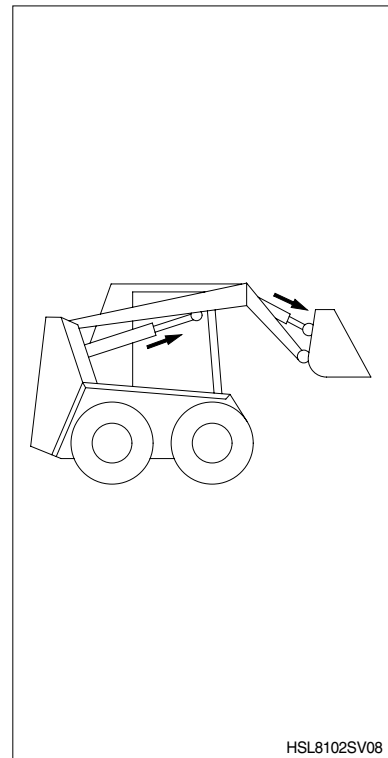

HSL8102SV08

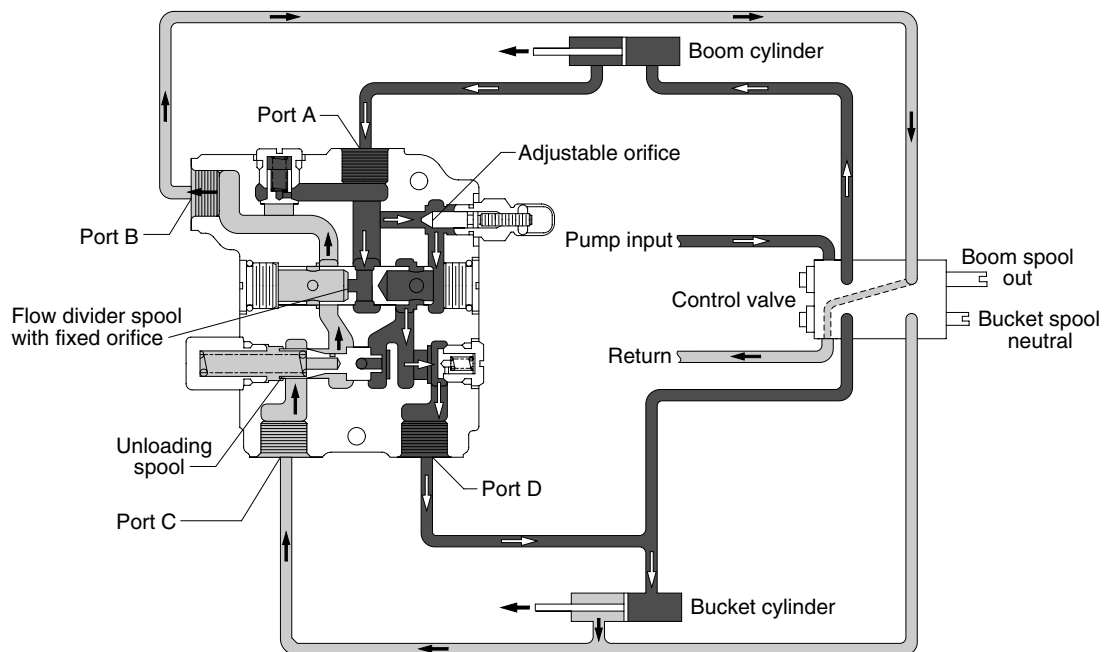

HSL8102SV01

- Trapped oil
- Pressure free oil
- Pressurized oil

### 4. BUCKET CYLINDER EXTENDED

1) In case the bucket cylinder strokes out first during the self level cycle the boom cylinder will continue to raise. The unloading spool will shift to the left and unload the flow going to the bucket cylinder head port. The oil flow goes back to tank, thus preventing the boom cylinder from stopping during the **raise** function.

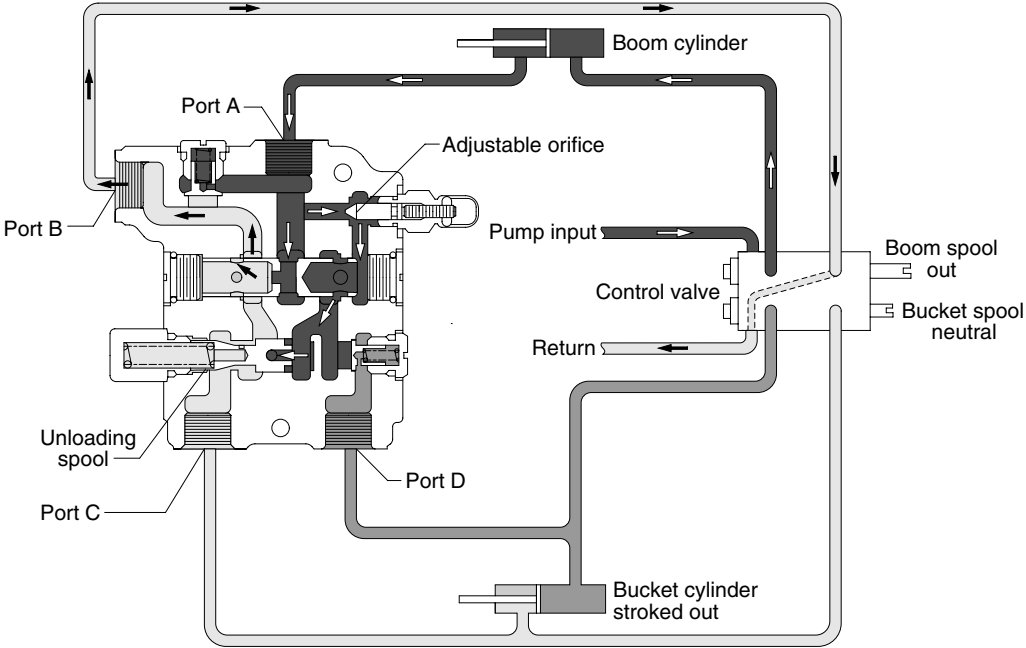
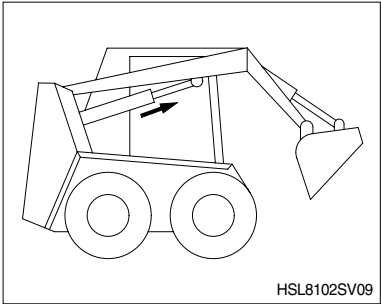

HSL8102SV02

- Trapped oil
- Pressure free oil
- Pressurized oil

## 5. RETRACTING BOOM CYLINDER

Moving boom spool in, the oil flow directed to port B of the self level valve .

Flow enters self level valve, opens lift check and flows out port A to the rod port on the boom cylinder.

Flow from head port directed back to the control valve a returns to tank.

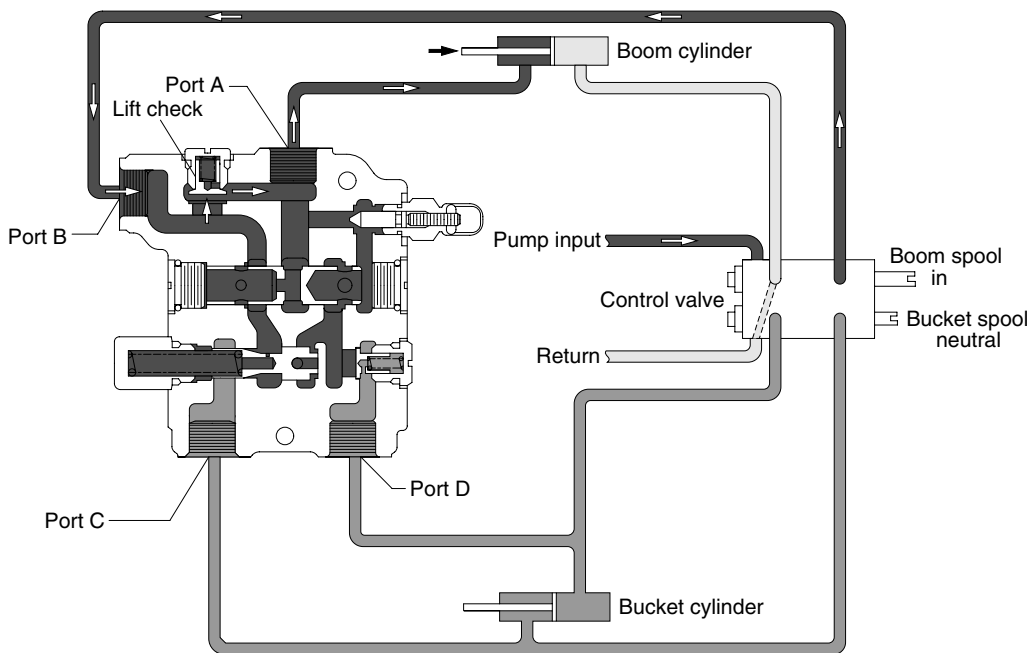
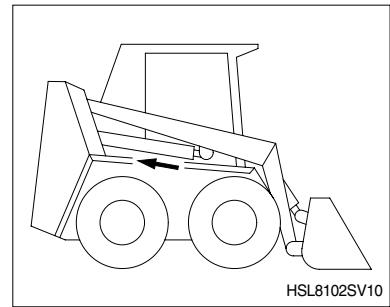

HSL8102SV03

- Trapped oil
- Pressure free oil
- Pressurized oil

## 6. EXTENDING BUCKET CYLINDER

With the bucket spool shifted out oil flow is directed from the control valve to the head port of the bucket cylinder. The flow also enters port D on the self level valve but is blocked by the lift check.

Return flow also enters port C on the self level valve and is blocked by the unloading spool.

Flow from the rod port is directed back to the control valve and returns to tank.

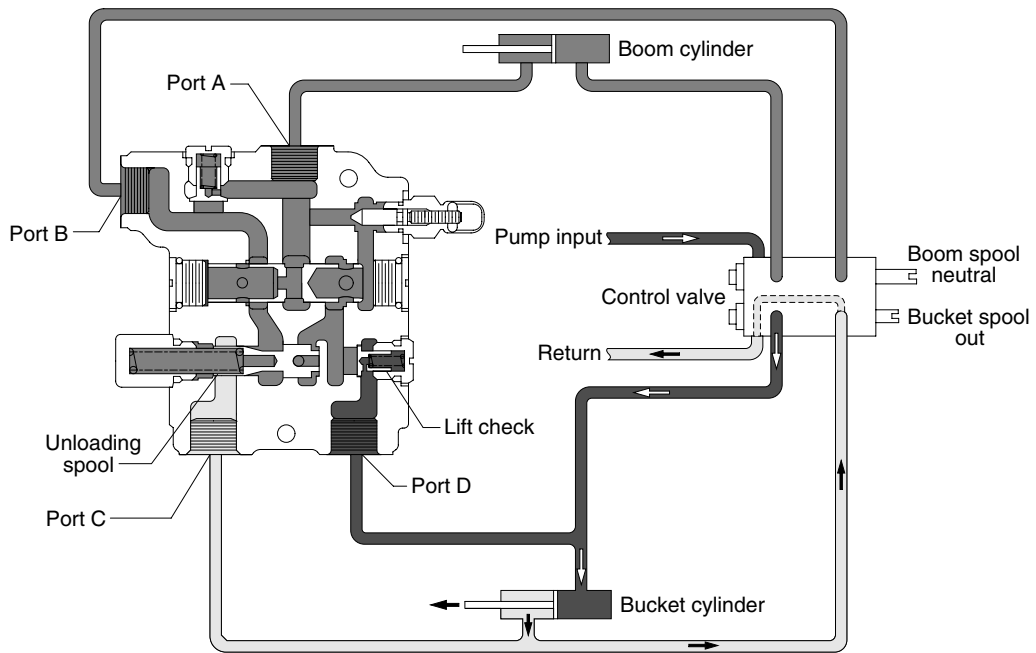
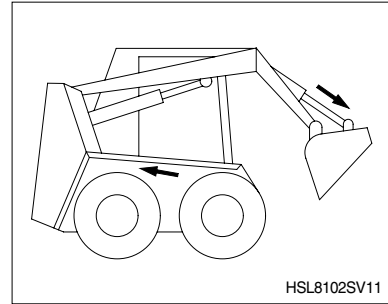

HSL8102SV04

- Trapped oil
- Pressure free oil
- Pressurized oil

## 7. RETRACTING BUCKET CYLINDER

With the bucket spool shifted in, oil flow is directed to the rod port of the bucket cylinder. Flow also enters port C on the self level valve through a tee connection but is blocked by the unloading spool. Oil returning from the head port is directed back to the control valve and returns to tank. Oil flow from the head port enters port D on the self level valve through a tee connection but is blocked by the lift check.

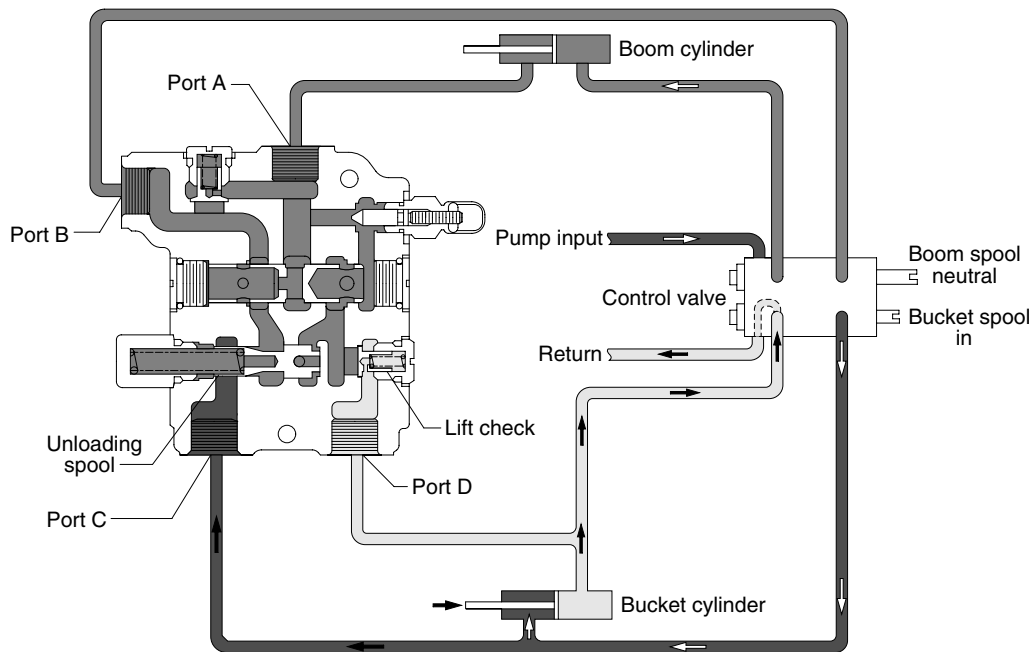
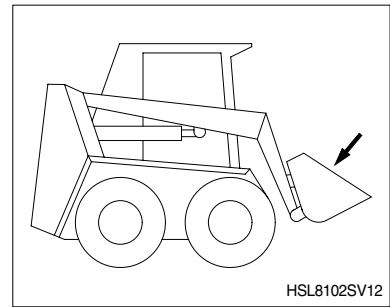

HSL8102SV05

- Trapped oil
- Pressure free oil
- Pressurized oil