

SECTION 3 ELECTRICAL SYSTEM

Group 1 Component location	3-1
Group 2 Wiring diagram	3-3
Group 3 Electrical component specification	3-16
Group 4 Connector destination	3-18

SECTION 3 ELECTRICAL SYSTEM

GROUP 1 COMPONENT LOCATION

1. LOCATION 1

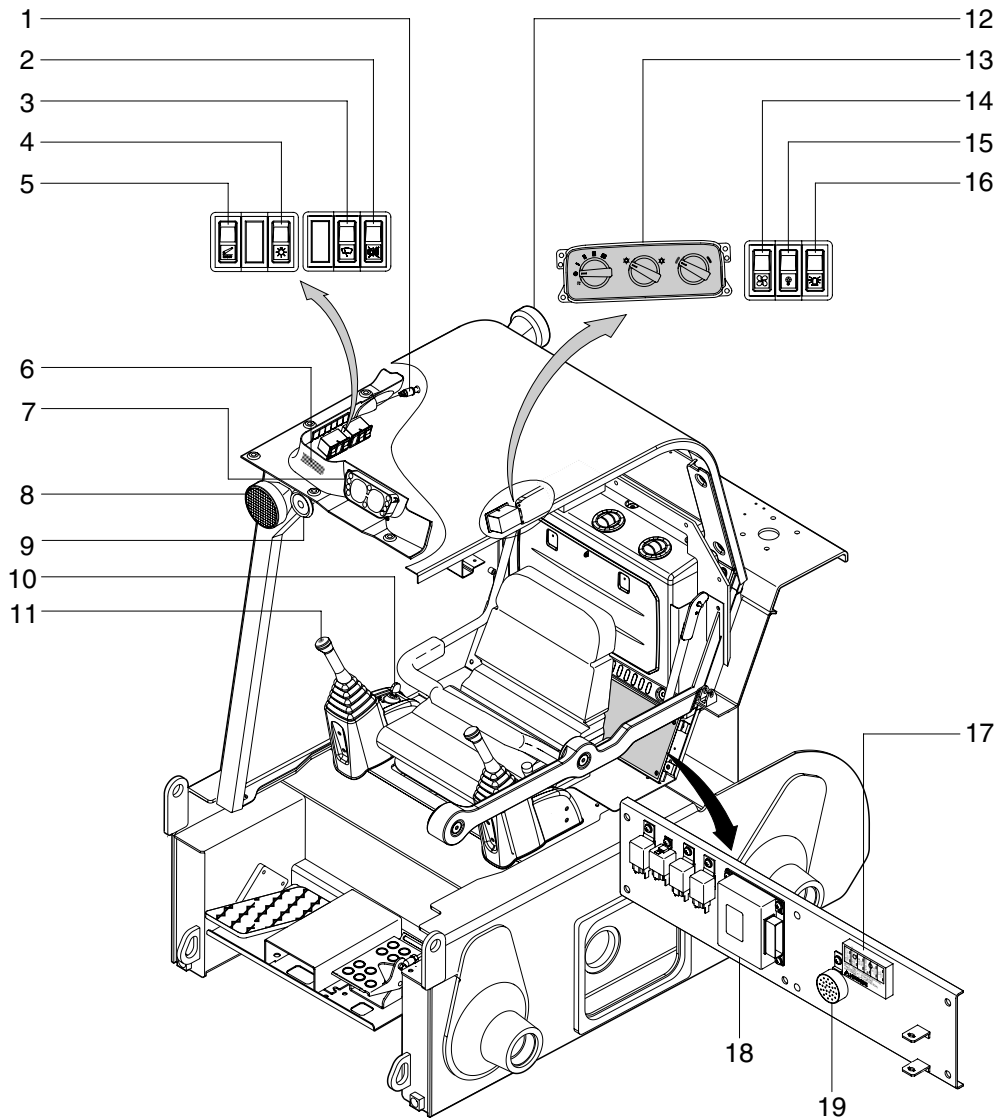

- | | | | |
|----|-------------------------|----|--------------------------------------|
| 1 | Cigar lighter | 11 | Horn switch |
| 2 | Buzzer stop switch | 12 | Rear work light(Optional) |
| 3 | Wiper switch(Optional) | 13 | Aircon & heater controller(Cab type) |
| 4 | Main light switch | 14 | Heater switch(Cab type) |
| 5 | Reset switch | 15 | Overload switch(Optional) |
| 6 | Room lamp | 16 | Beacon switch(Optional) |
| 7 | Warning indicator panel | 17 | Fuse box |
| 8 | Front work light | 18 | Control unit |
| 9 | Horn | 19 | Audible alarm |
| 10 | Start switch | | |

8007EL02

LOCATION 2

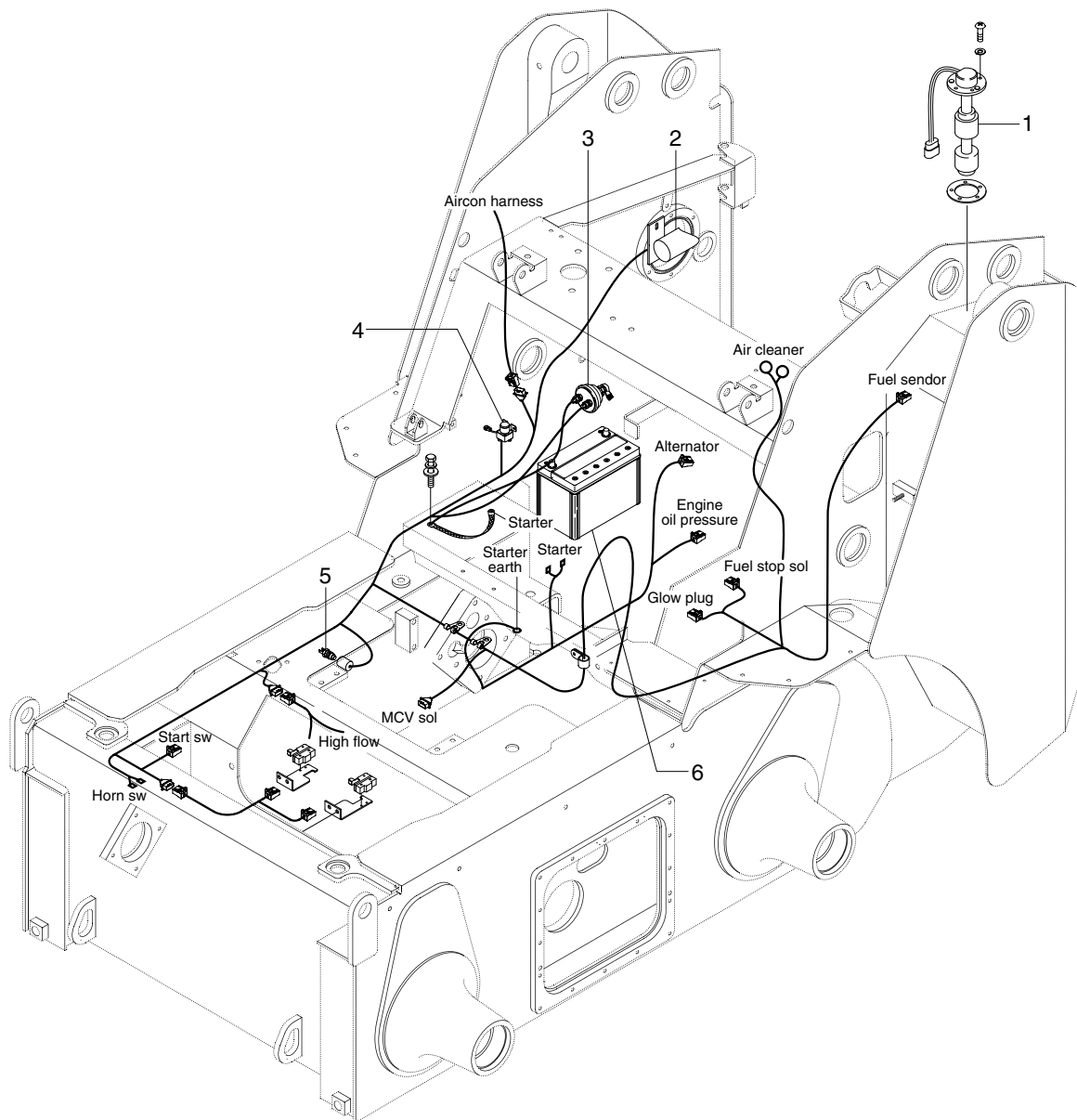

8007EL02-1

- 1 Fuel sender
- 2 Back up buzzer
- 3 Master switch

- 4 Start relay
- 5 Water temperature switch
- 6 Battery

1. POWER CIRCUIT

The negative terminal of the battery is grounded to the machine chassis.

When the start switch is in the OFF position, the current flows from the positive battery terminal as shown below.

1) OPERATING FLOW

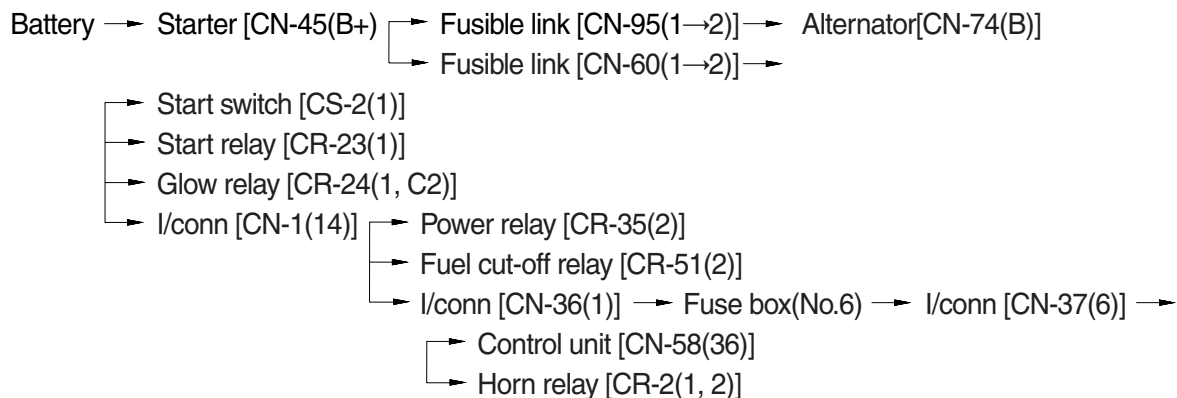

※ I/conn : Intermediate connector

2) CHECK POINT

Engine	Start switch	Disconnect switch	Check point	Voltage
OFF	OFF	ON	① - GND(Battery) ② - GND(Fusible link) ③ - GND(Fuse box No.6) ④ - GND(Start switch B terminal)	DC 10~14V

※ GND : Ground

POWER CIRCUIT

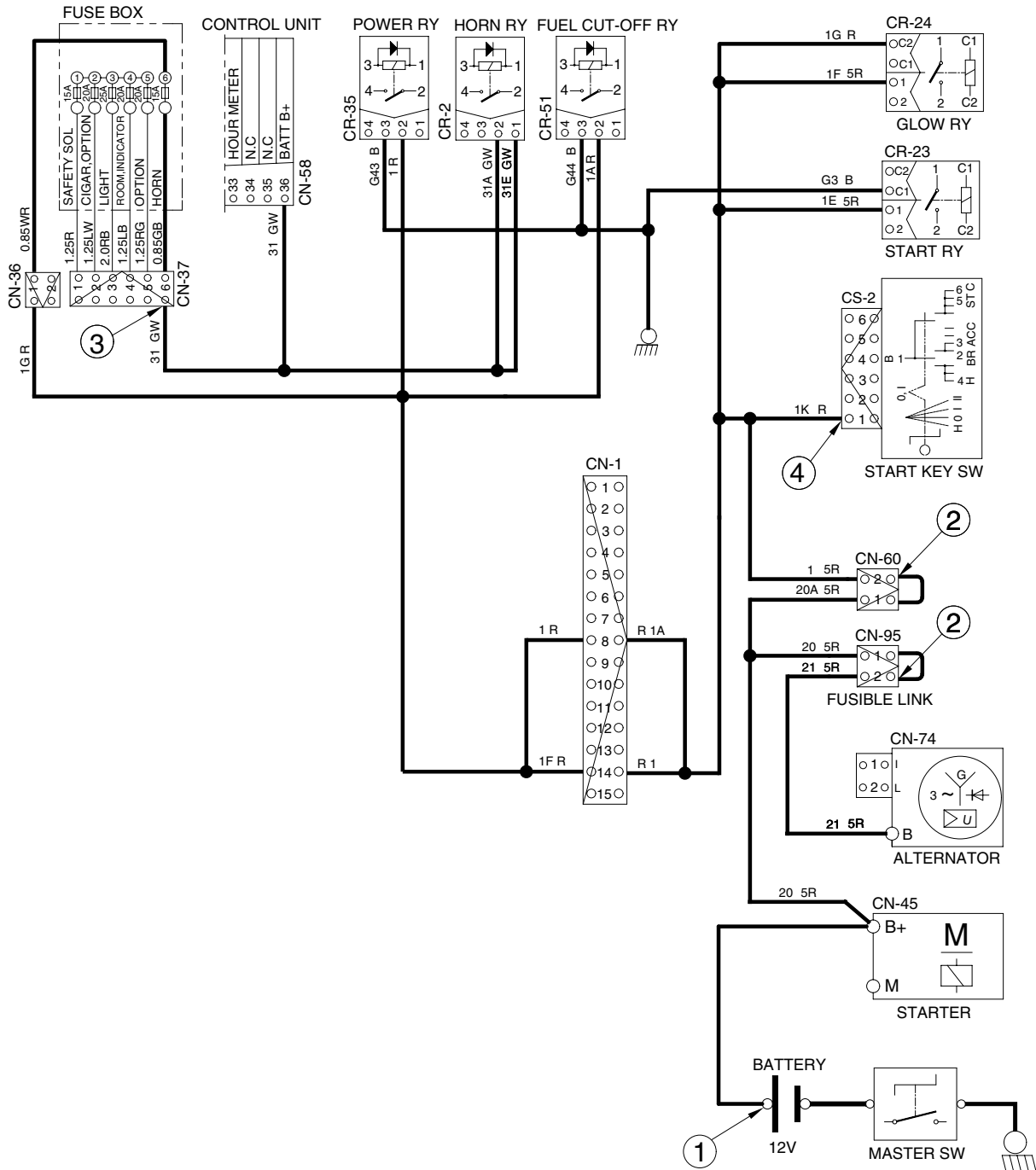

8007EL03

2. STARTING CIRCUIT

1) OPERATING FLOW

Battery (+) terminal → Starter(B⁺ terminal) → Fusible link [CN-60] → Start switch [CS-2(1)]
 → Start relay [CR-23(1)]

(1) When start key switch is in ON position

Start switch ON → [CS-2(2)] → Diode [Do-2] → Alternator [CN-74(1)]
 → [CS-2(3)] → I/conn [CN-1(3)] → Power relay [CR-35(1), (2)→(4)] →
 I/conn [CN-36(2)] → Fuse box(No.2) → I/conn [CN-1(5)] →
 Engine stop solenoid [CN-79(1)]

(2) When start key switch is in START position

Start switch START [CS-2(5)] → I/conn[CN-1(1)] → Anti-restart relay[CR-5(30)→(87a)]
 → Fuel cut-off relay[CR-51(1)→(4)] → Stop solenoid[CN-79(2)]
 → I/conn[CN-1(7)] → Start relay[CR-23(C2)→(2)]
 → Starter[CN-45(M)]

2) CHECK POINT

Engine	Start switch	Disconnect switch	Check point	Voltage
Operating	START	ON	① - GND(Battery) ② - GND(Fusible link) ③ - GND(Start switch BR terminal) ④ - GND(Start switch ACC terminal) ⑤ - GND(Start switch ST terminal) ⑥ - GND(Fuse No.2)	DC 10~14.5V

※ GND : Ground

※ The disconnect switch(Master switch) is assembled as an option.

※ Do not operate the starter longer than 30 seconds.

⚠ Do not disconnect or short any lead wire while the starter is operating.

STARTING CIRCUIT

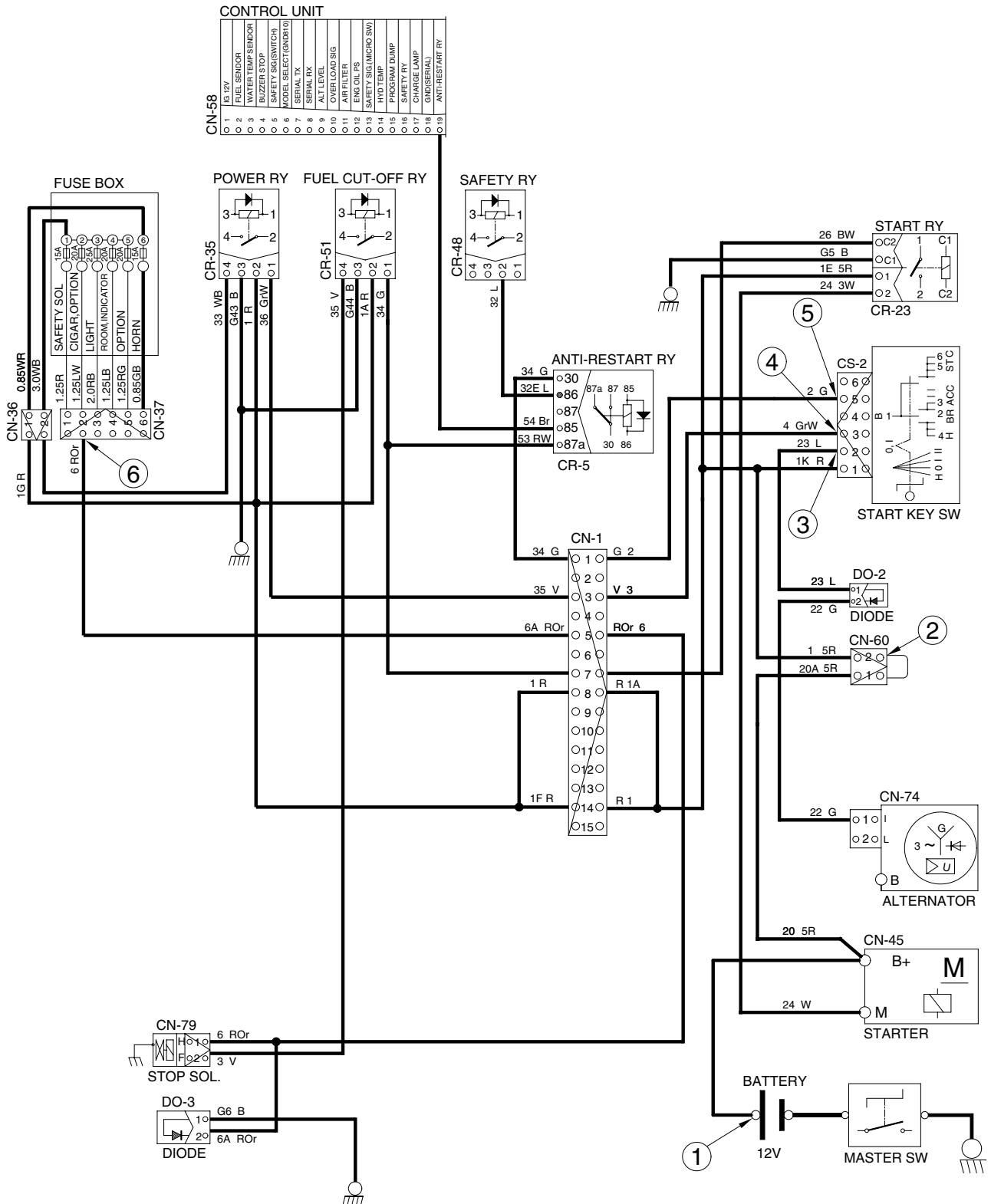

8007EL04

3. CHARGING CIRCUIT

When the starter is activated and the engine is started, the operator releases the start switch to the ON position. Charging current generated by the operating alternator flows into the battery through the fusible link CN-95.

The current also flows from the alternator to each electrical component through the fusible link CN-20 and the fuse box.

1) OPERATING FLOW

(1) Warning indicator flow

Alternator L terminal [CN-74(2)] → I/conn [CN-1(4)] → Control unit [CN-58(9)→(17)] → I/conn [CN-56(9)] → Charging warning lamp ON.

(2) Charging flow

Alternator B → Fusible link [CN-95(1, 2)] → Starter [CN-45(B+)] → Battery(+) terminal → Charging

2) CHECK POINT

Engine	Start switch	Disconnect switch	Check point	Voltage
Operating	ON	ON	① - GND(Battery) ② - GND(Fusible link) ③ - GND(Alternator B terminal) ④ - GND(Alternator I terminal) ⑤ - GND(Charging lamp) ⑥ - GND(Fuse box)	DC 10~14.5V

※ GND : Ground

※ The disconnect switch (Master switch) is assembled as an option.

※ When using an arc welder, always disconnect the ground lead from the battery to prevent alternator or battery damage.

※ Attach the welding ground clamp as close to the weld area as possible to prevent welding current from damaging the bearings of the alternator.

※ Do not disconnect the battery when the engine is running. The voltage surge can damage the diode and resistors in the electrical system.

※ Do not disconnect an electric wire before the engine is stopped and the switch are OFF.

CHARGING CIRCUIT

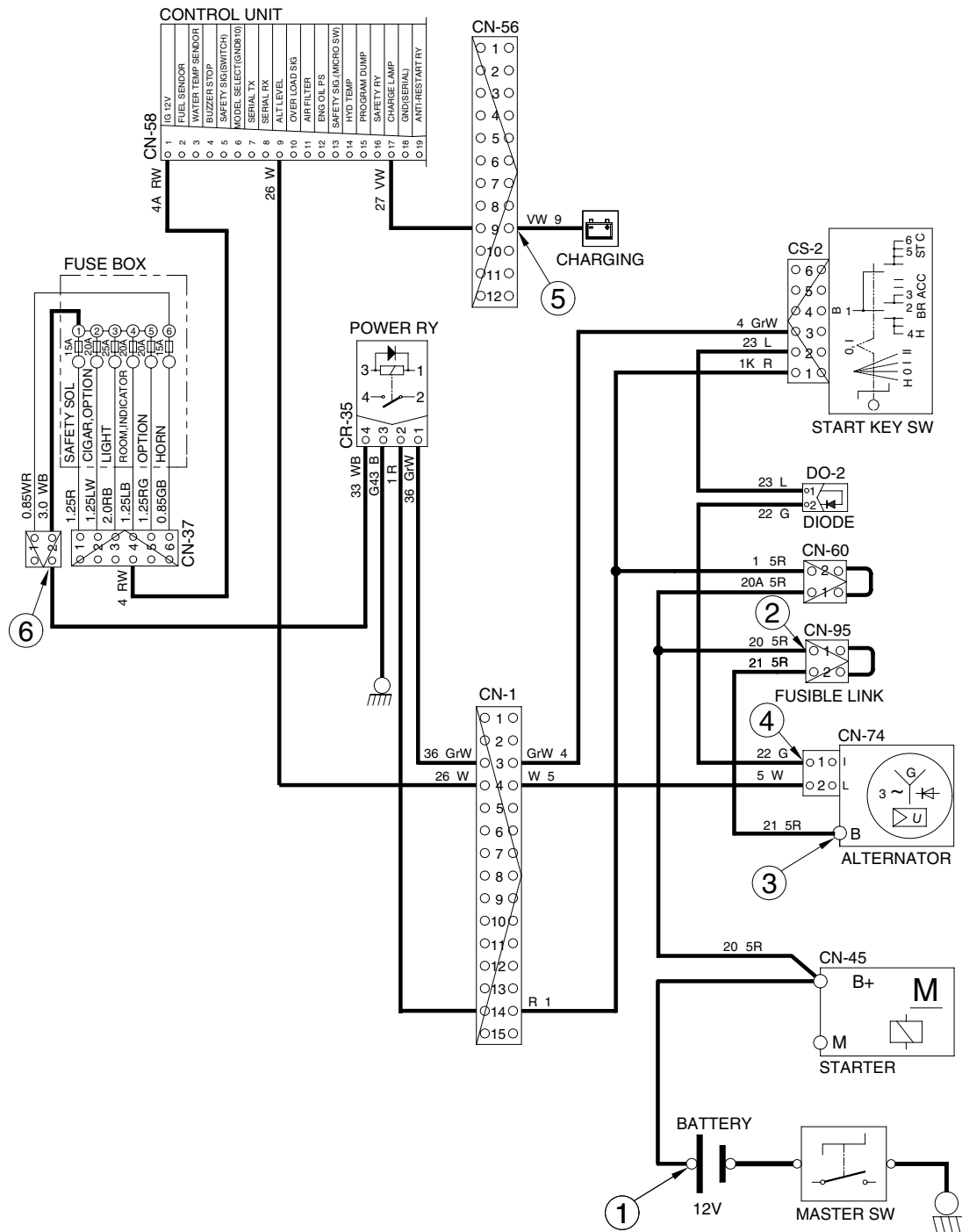

8007EL05

4. LAMP CIRCUIT

1) OPERATING FLOW

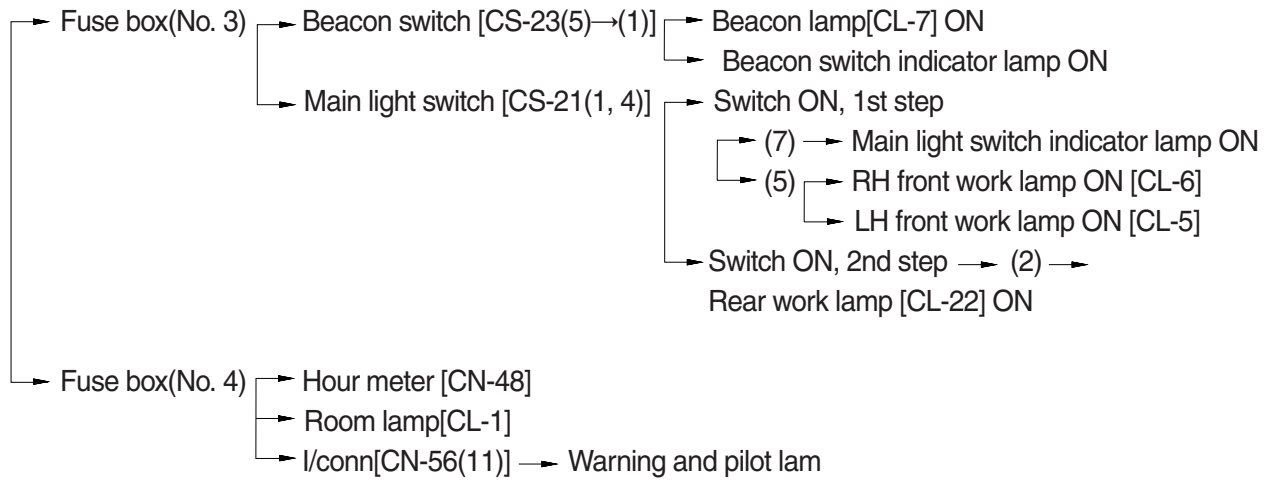

2) CHECK POINT

Engine	Start switch	Disconnect switch	Check point	Voltage
Stop	ON	ON	① - GND(Fuse No.3) ② - GND(Fuse No.4) ③ - GND(Front work lamp) ④ - GND(Rear work lamp) ⑤ - GND(Switch power input) ⑥ - GND(Room lamp)	DC 10~13V

※ GND : Ground

※ The disconnect switch (Master switch) is assembled as an option.

LAMP CIRCUIT

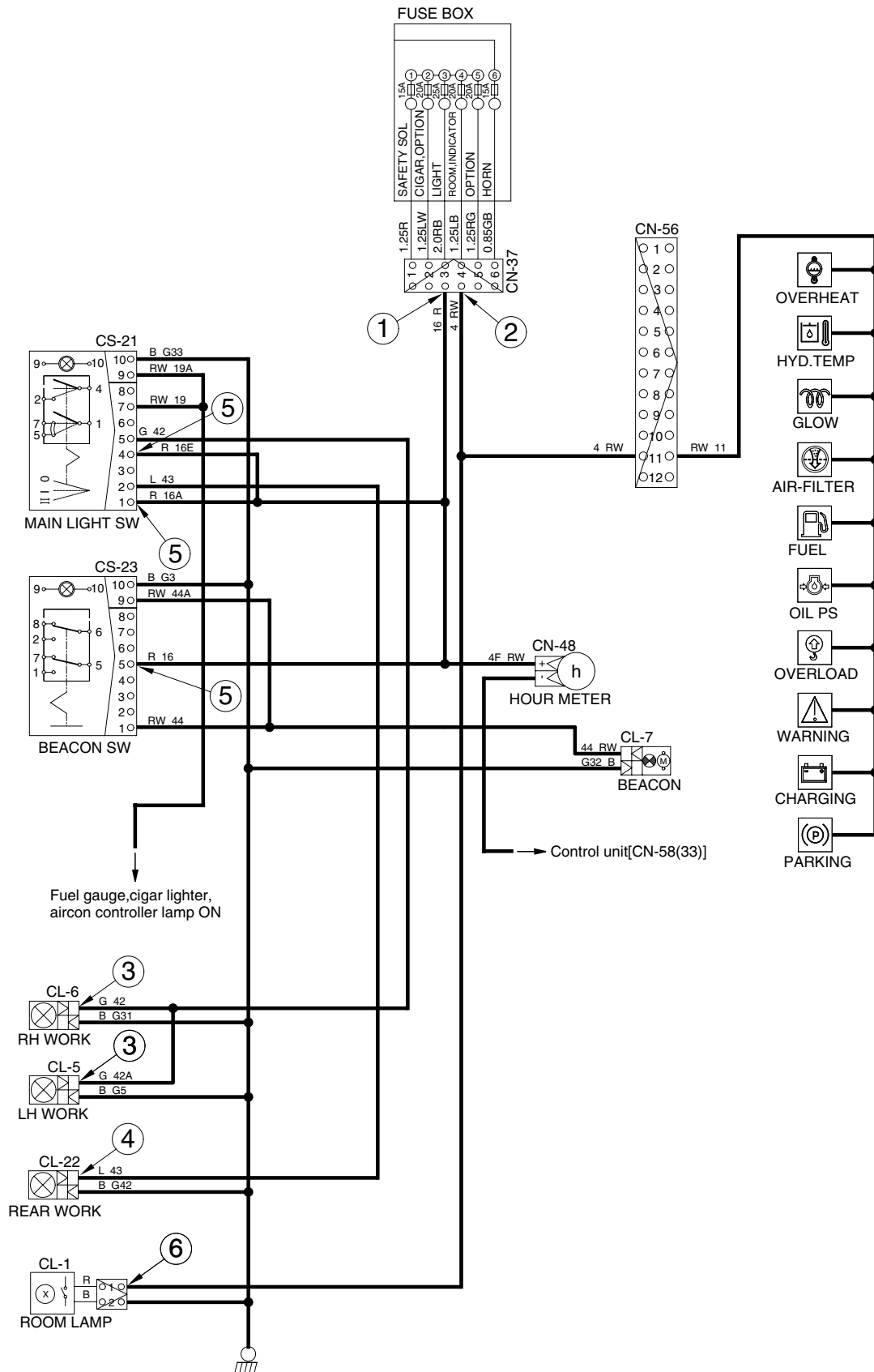

5. PREHEATING CIRCUIT

When the start switch is set to the ON position, the control unit starts counting the specified time and the indicator is lit. After 5~20 seconds, the control unit turns OFF the indicator to indicate that preheating is completed.

1) OPERATING FLOW

※ **Start switch : ON position**

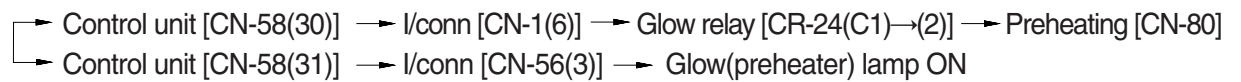

2) CHECK POINT

Engine	Start switch	Disconnect switch	Check point	Voltage
Stop	ON	ON	① - GND(Fusible link) ② - GND(Fusible link) ③ - GND(Start switch) ④ - GND(Glow relay) ⑤ - GND(preheater)	DC 10~13V

※ GND : Ground

※ The disconnect switch (Master switch) is assembled as an option.

PREHEATING CIRCUIT

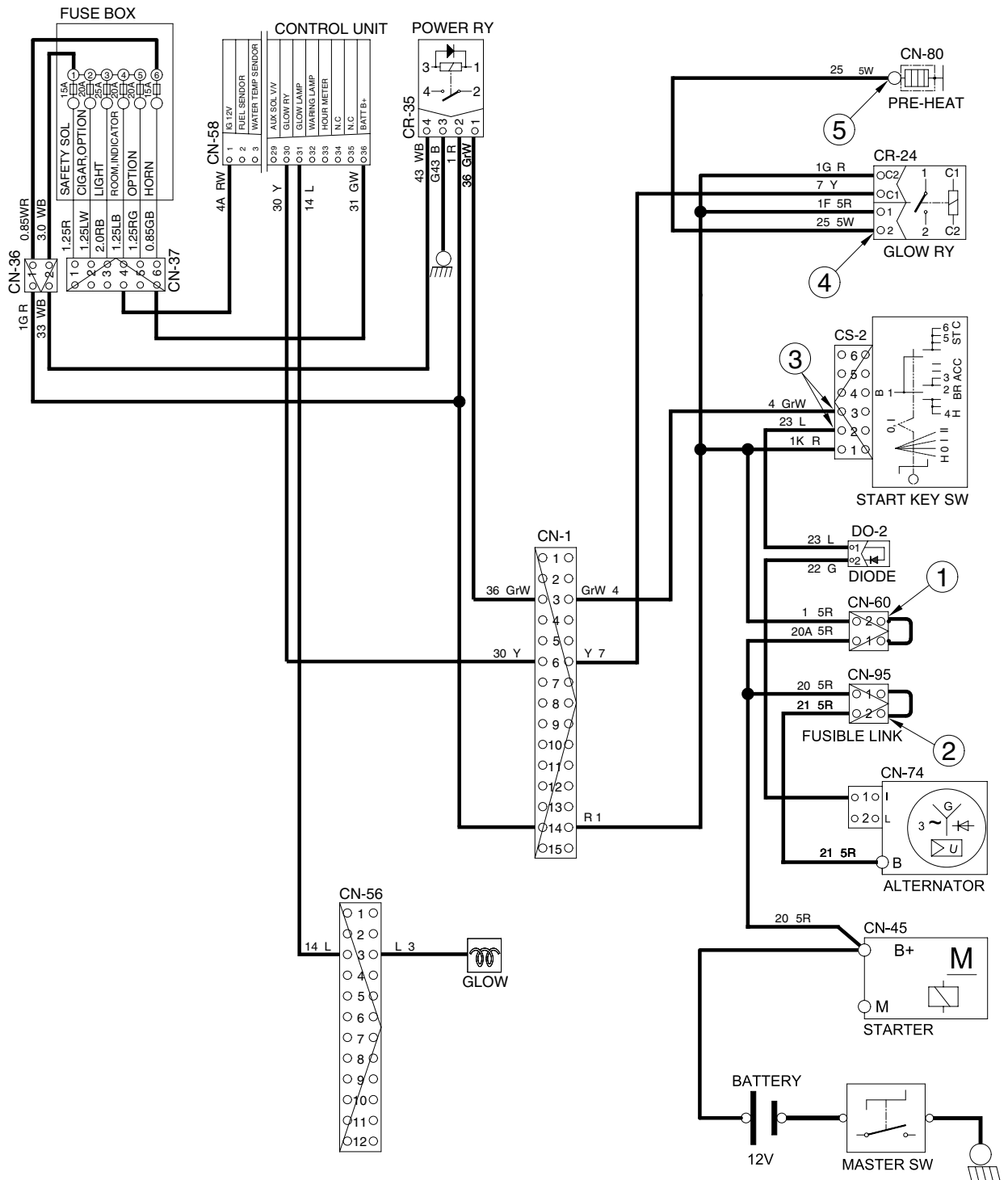

8007EL07

6. SAFETY CIRCUIT

After an operator brings the seat bar down and starts the engine, the operator must momentarily press the reset switch to get the boom/bucket function unlocked.

The hydraulic system of the loader will remain active until the seat bar is raised or the start switch is turned OFF.

1) OPERATING FLOW

Fuse box(No.1) → I/conn [CN-37(1)] → Micro switch [CS-4(1)]
 → Safety relay [CR-48(2)]

※ Seat bar : Down position

Micro switch [CS-4(1)→(2)] → I/conn [CN-8(1)→(2)] → Safety relay [CR-48(1)]
 → I/conn [CN-2(8)] → Solenoid MCV [CN-130A(2)]

※ Reset switch : ON position

Safety(Reset) switch [CS-52(6)→(2)] → Control unit [CN-58(5)→(16)] →
 Safety relay [CR48(3)→(4)] → I/conn [CN-2(6)] → Parking solenoid [CN-71(2)]
 → Safety solenoid [CN-68]

※ Once the safety solenoid is operated, the solenoid is energized continuously till the seat bar is raised or the start switch is turned OFF.

2) CHECK POINT

Engine	Start switch	Disconnect switch	Check point	Voltage
Operating	ON	ON	① - GND(Fuse No.1) ② - GND(Micro switch) ③ - GND(Solenoid relay) ④ - GND(Solenoid valve)	DC 10~14.5V

※ GND : Ground

※ The disconnect switch is assembled as an option.

SAFETY CIRCUIT

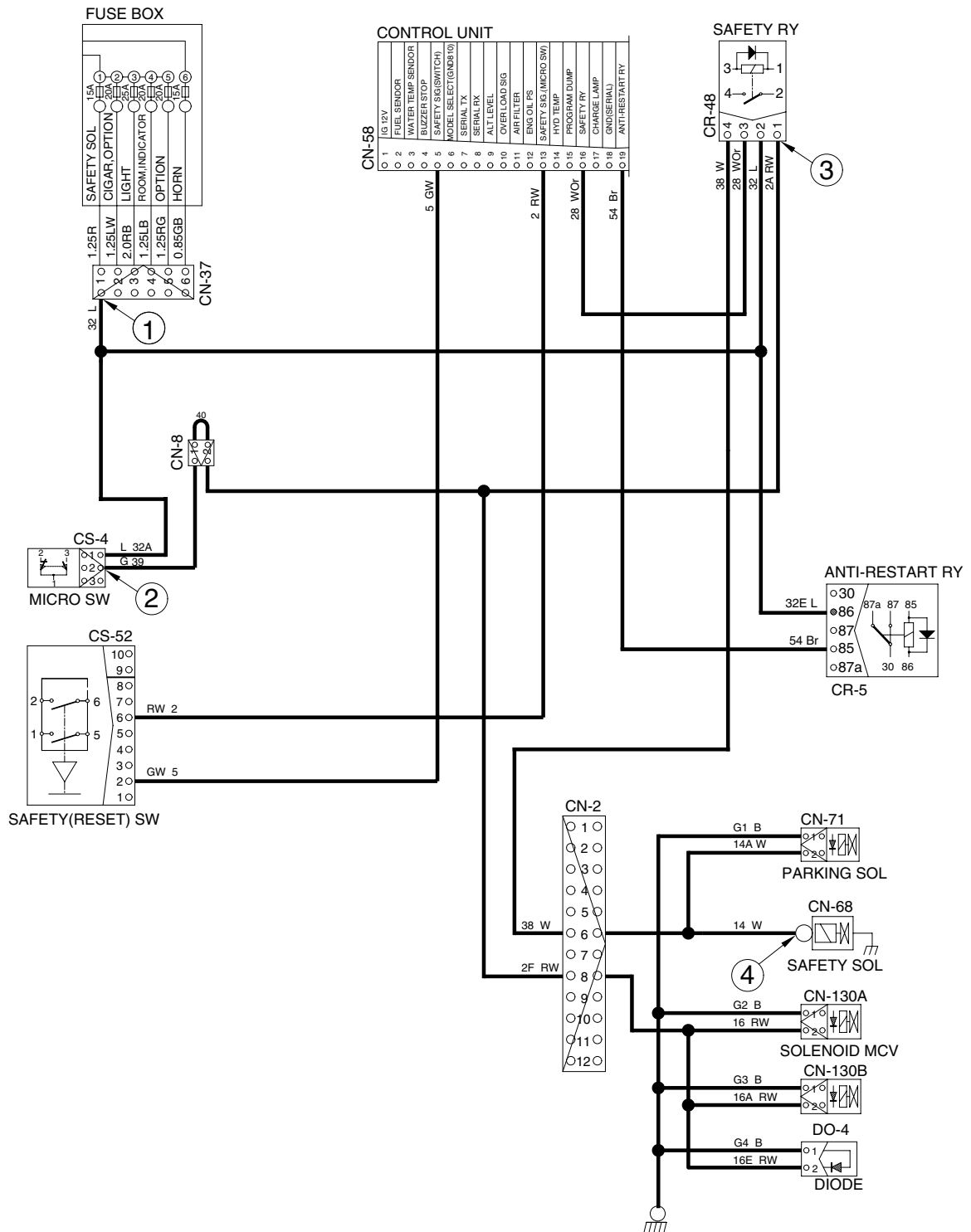

8007EL08