

SECTION 4 POWER TRAIN

Group 1	Power train component	-----	4-1
Group 2	Front and rear axle	-----	4-2
Group 3	Gear box	-----	4-6

SECTION 4 POWER TRAIN

GROUP 1 POWER TRAIN COMPONENT

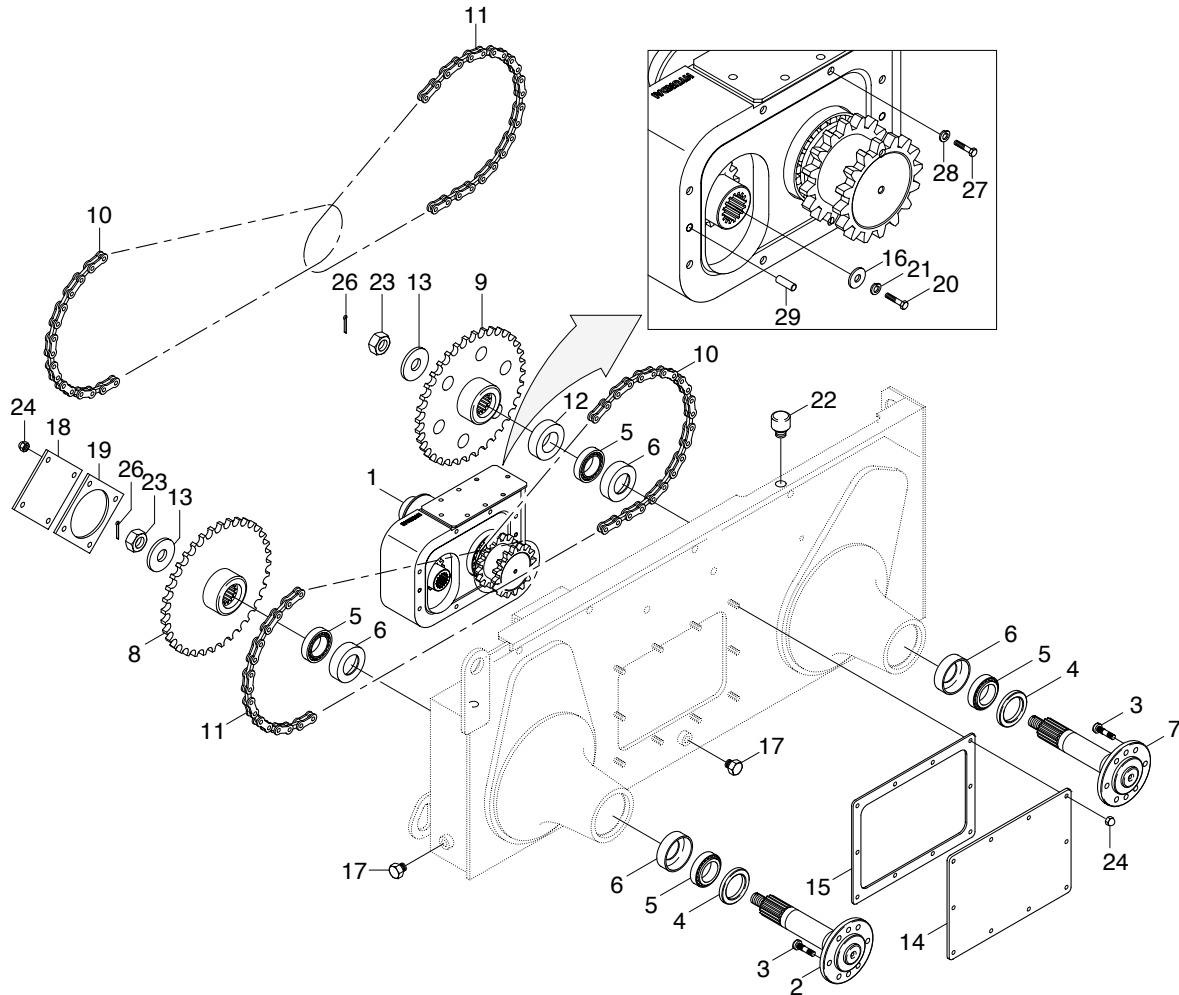

- | | | | | | |
|----|----------------------|----|----------------------|----|------------------|
| 1 | Gear box assembly | 11 | Chain assembly | 21 | Spring washer |
| 2 | Front axle shaft | 12 | Rear sprocket spacer | 22 | Air breather |
| 3 | Wheel bolt | 13 | Washer | 23 | Slotted nut |
| 4 | Seal | 14 | Cover | 24 | Self locking nut |
| 5 | Taper roller bearing | 15 | Gasket | 26 | Split pin |
| 6 | Bearing cup | 16 | Washer | 27 | Hexagon bolt |
| 7 | Rear axle shaft | 17 | Hexagon plug | 28 | Spring washer |
| 8 | Front sprocket | 18 | Cover | 29 | Dowel pin |
| 9 | Rear sprocket | 19 | Gasket | | |
| 10 | Chain assembly | 20 | Hexagon bolt | | |